

**CARVIN**

12340 World Trade Drive  
San Diego, CA 92128  
(858) 487-1600  
FAX 487-8629

---

**PA620 / PA410  
SYSTEM MASTER**

DRAWN BY: E. PETERSEN	DATE: 26SEP00
APPROVED: _____	DATE: _____
PCB NO: 30-62004	REV: F
ASSY: 80-62004	REV: E
NO: 80-42004	REV: _____
REVISED BY: E. PETERSEN	DATE: 27AUG02

5. A1 IS TYPE 5532 OP AMP.
  4. ALL RESISTORS IN OHMS.
  3. ALL CAPACITORS IN MICROFARADS, EXCEPT AS NOTED
  2. ALL DIODES ARE TYPE 1N4003 EXCEPT AS NOTED.
  1. ALL GROUNDS ARE EXCEPT AS NOTED.
- NOTES: UNLESS OTHERWISE SPECIFIED**



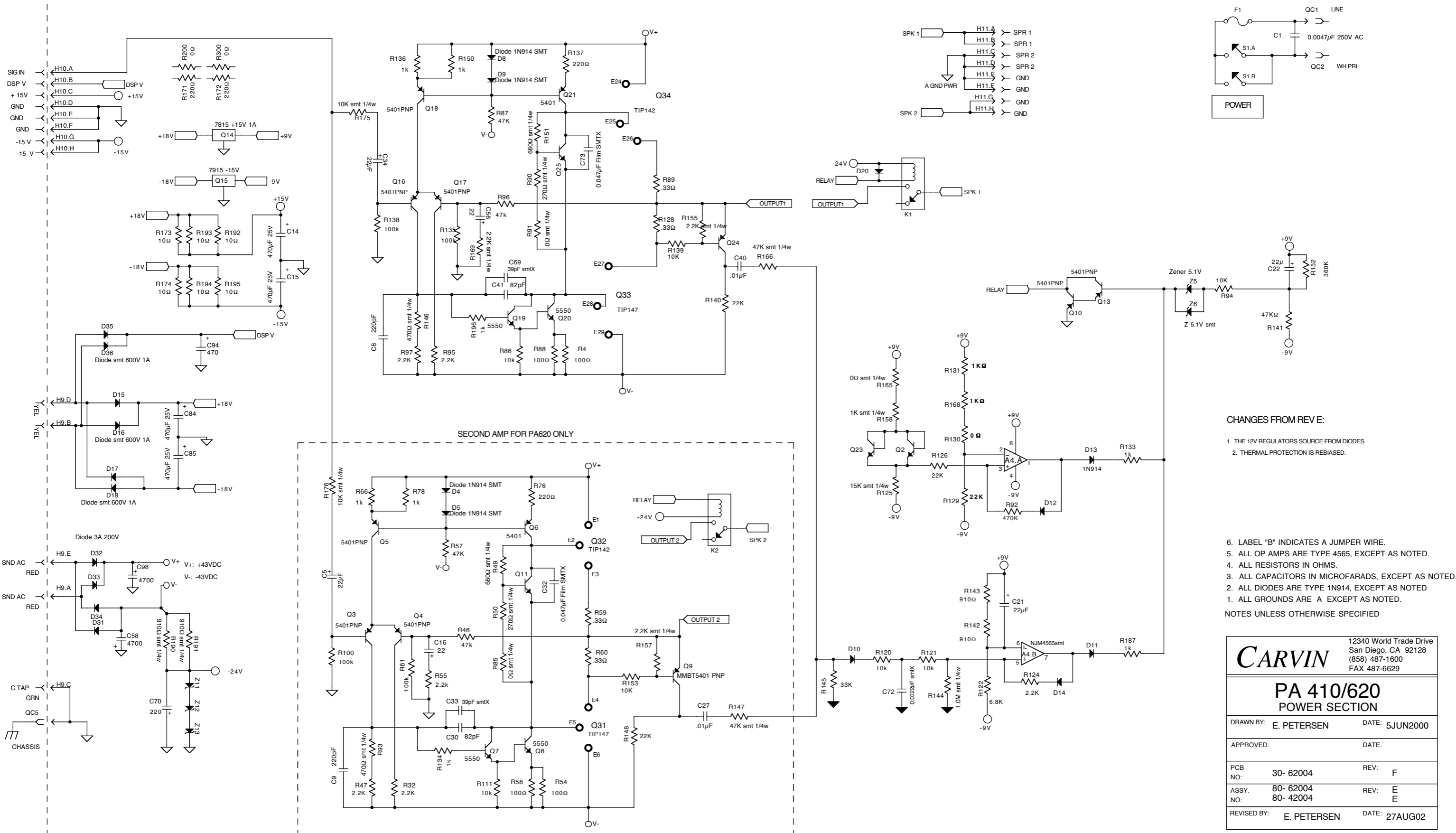

- CHANGES FROM REV. E:**
- THE 12V REGULATORS SOURCE FROM DIODES.
  - THERMAL PROTECTION IS REBIASED.
  - ALL OP AMPS ARE TYPE 4565, EXCEPT AS NOTED.
  - ALL RESISTORS IN OHMS.
  - ALL CAPACITORS IN MICROFARADS, EXCEPT AS NOTED.
  - ALL DIODES ARE TYPE 1N914, EXCEPT AS NOTED.
  - ALL GROUNDS ARE A EXCEPT AS NOTED.
- NOTES UNLESS OTHERWISE SPECIFIED

		12340 World Trade Drive San Diego, CA 92128 (858) 487-1600 FAX 487-6629	
		<b>PA 410/620</b> <b>POWER SECTION</b>	
DRAWN BY:	E. PETERSEN	DATE:	5JUN2000
APPROVED:		DATE:	
PCB NO:	30- 62004	REV:	F
ASSY. NO:	80- 62004	REV:	E
	80- 42004	REV:	E
REVISED BY:	E. PETERSEN	DATE:	27AUG02