

NOTE: B1 IS CUT, AND B2 INSTALLED FOR 240V.
B2 IS CUT, AND B1 INSTALLED FOR 120V ONLY.

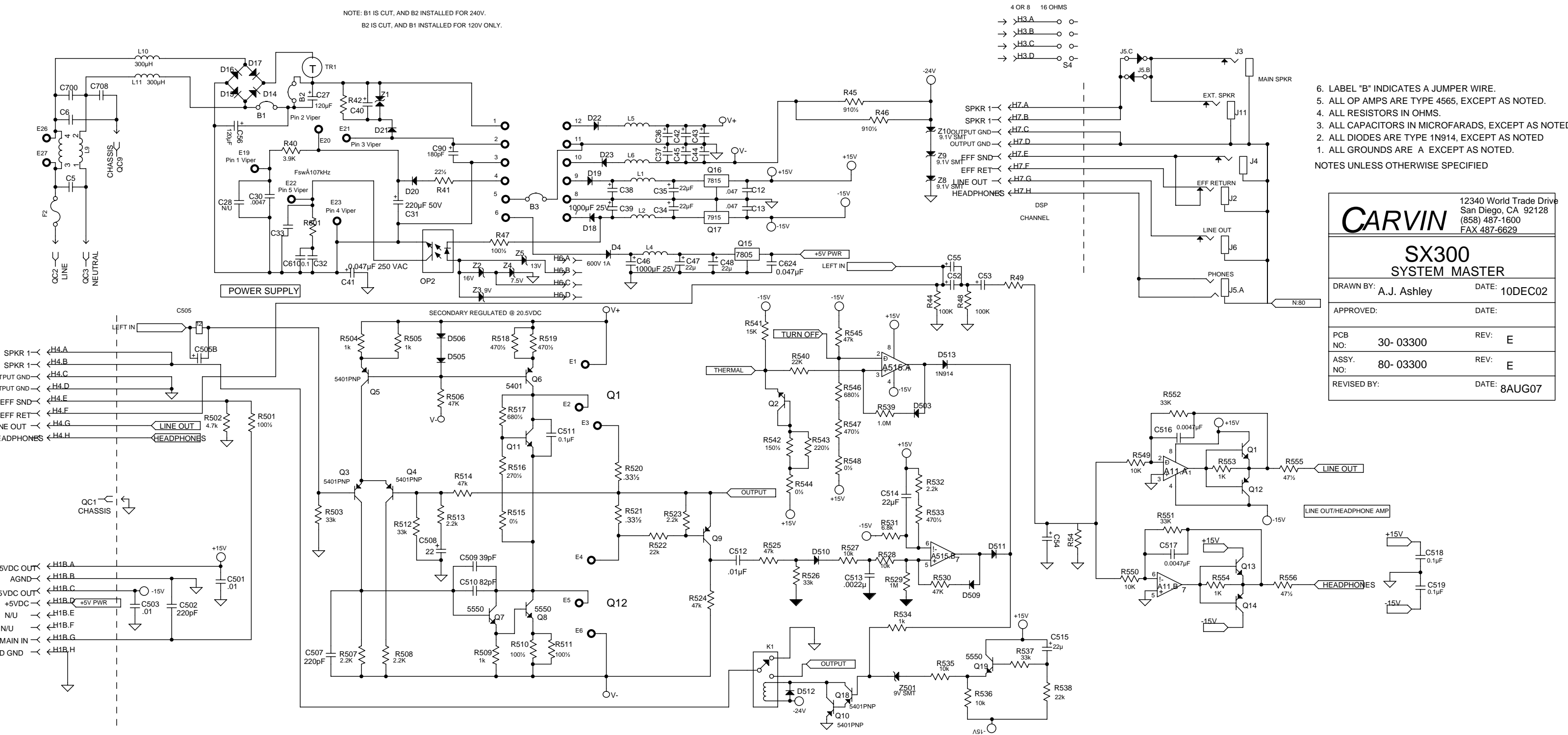

- 6. LABEL "B" INDICATES A JUMPER WIRE.
 - 5. ALL OP AMPS ARE TYPE 4565, EXCEPT AS NOTED.
 - 4. ALL RESISTORS IN OHMS.
 - 3. ALL CAPACITORS IN MICROFARADS, EXCEPT AS NOTED.
 - 2. ALL DIODES ARE TYPE 1N914, EXCEPT AS NOTED.
 - 1. ALL GROUNDS ARE A EXCEPT AS NOTED.
- NOTES UNLESS OTHERWISE SPECIFIED

CARVIN		12340 World Trade Drive San Diego, CA 92128 (858) 487-1600 FAX 487-6629	
SX300 SYSTEM MASTER			
DRAWN BY: A.J. Ashley		DATE: 10DEC02	
APPROVED:		DATE:	
PCB NO: 30- 03300	REV: E		
ASSY. NO: 80- 03300	REV: E		
REVISED BY:	DATE: 8AUG07		

