

LF356H

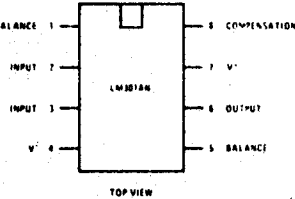

LM301

IC 100/200

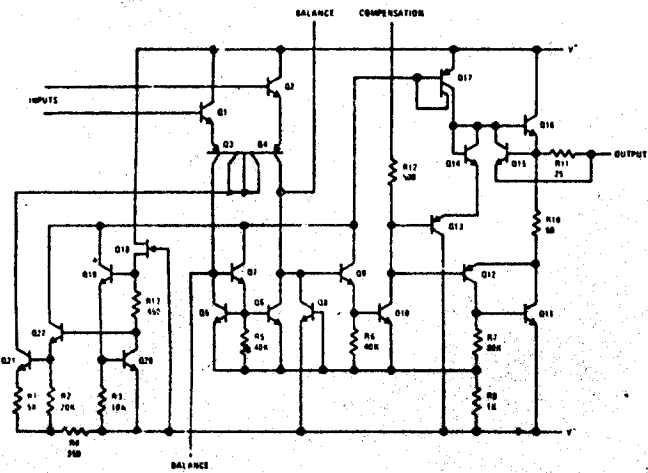
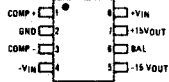
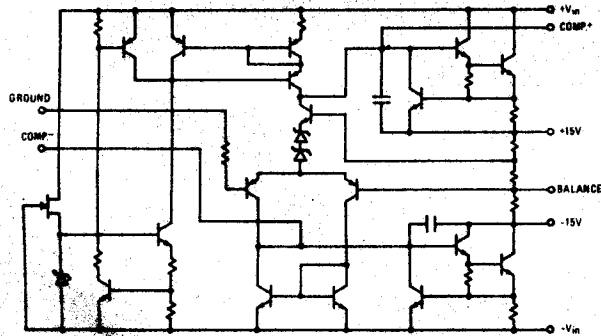

RC4195 DN

Q100-200-Q22
= PN 4250

Q101-201 = TZ-81

01 = 2N3859A

NOTES:

1. This circuit starts SN IC-18801.
2. This schematic applies only to board #4150. (SN 17201 to 17401 used a modified board #9656.)
3. All resistors in ohms, all capacitors in mfd unless otherwise specified.
4. Input selector shown in Phono 1 (full ccw) looking from front panel.
5. Tape Monitors 1 and 2 shown inactive (out).
6. Lo Filter shown inactive (out).
7. Loudness switch shown inactive (out).
8. Balance control shown in normal position.
9. Panorama shown in mono position.
10. Tone Cancel switch shown in cancel (in) position.
11. Hi Filter shown inactive (out).
12. Output Attenuator shown in 0 dB position.
13. Schematic designations are as follows:
Parts common to both channels: 1-29 (Phono Board), 30-59 (Main Board), 60-99 (Chassis). The same number sequences preceded by 1 or 2 indicate left channel and right channel.
14. In early units, the Balance control (R30A,B) was 500K, the Panorama control (R31A,B,C) was 1M.
15. R139/239 and R140/240 may be mounted either on the PC board or on the step attenuator.

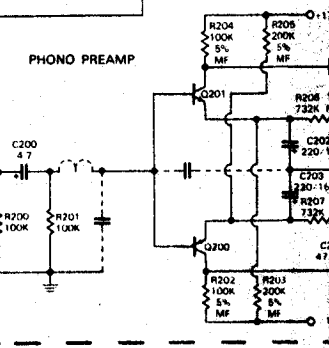
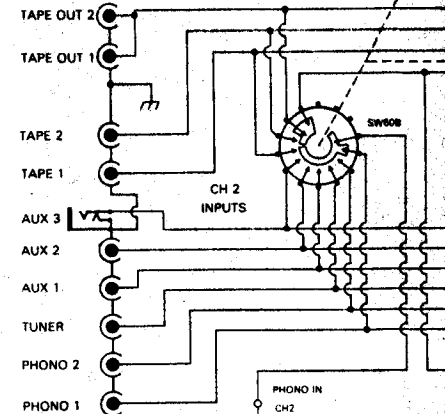
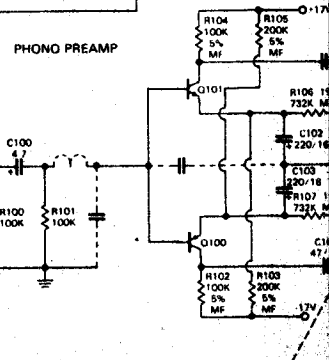
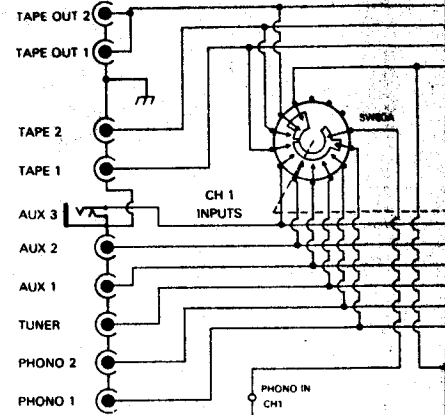

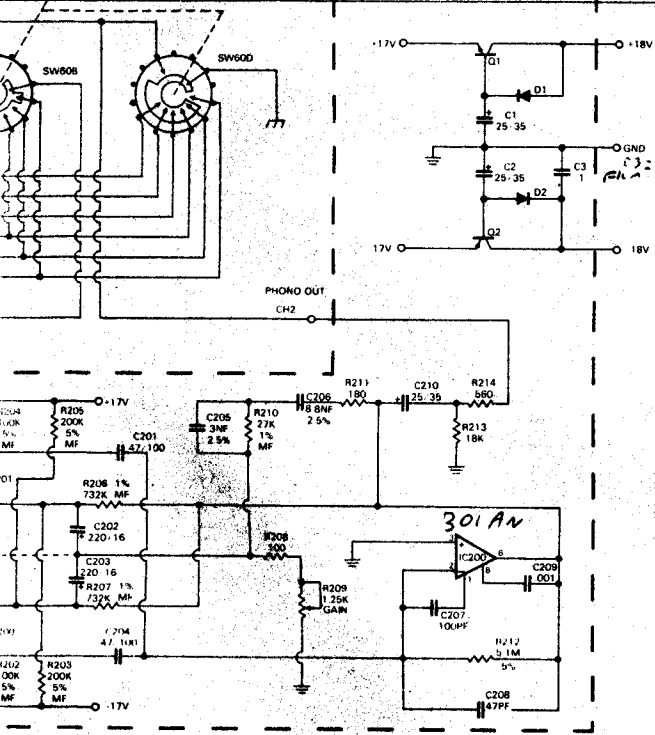
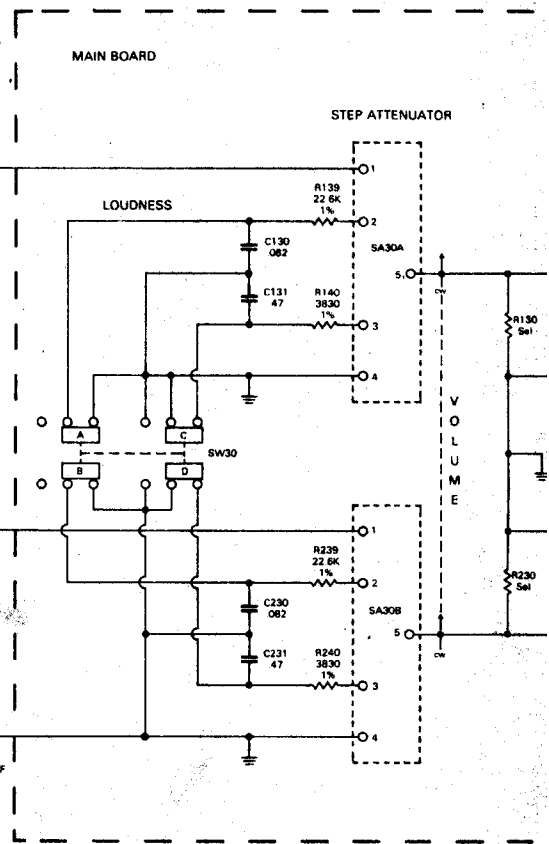
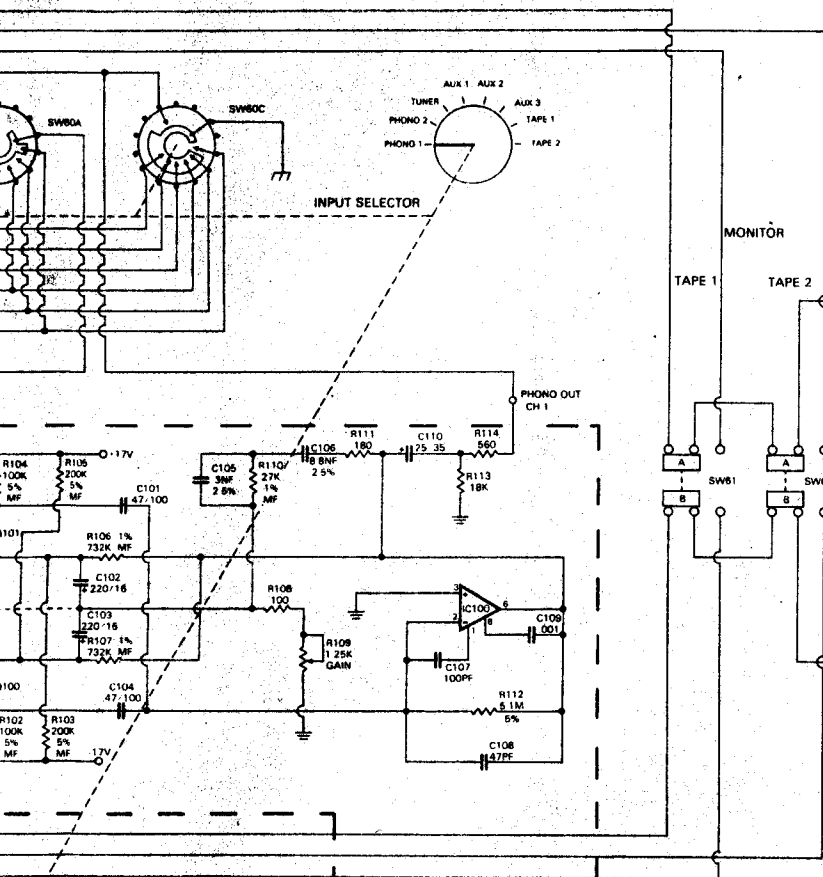

01-02
 ~ 124148

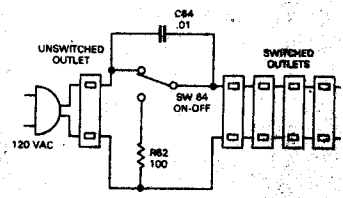

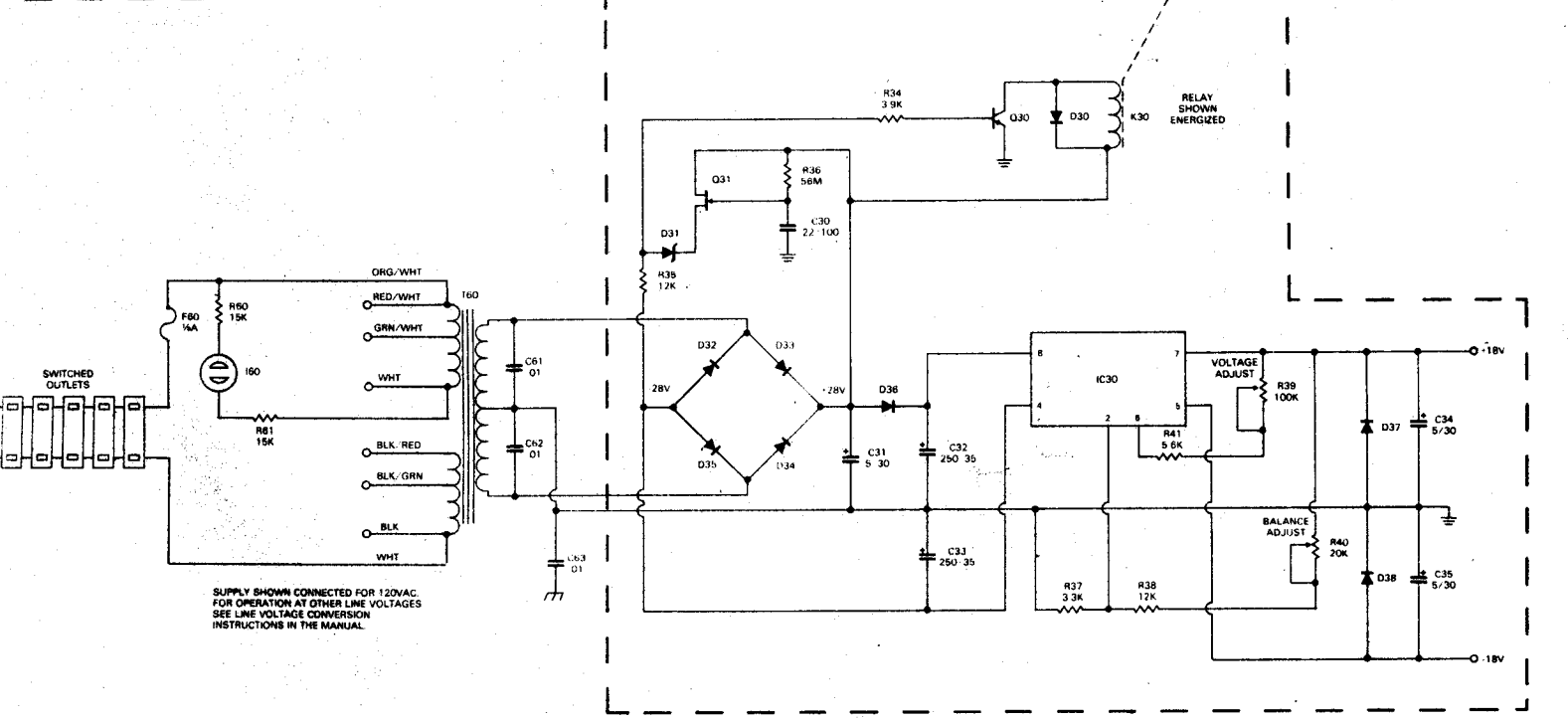
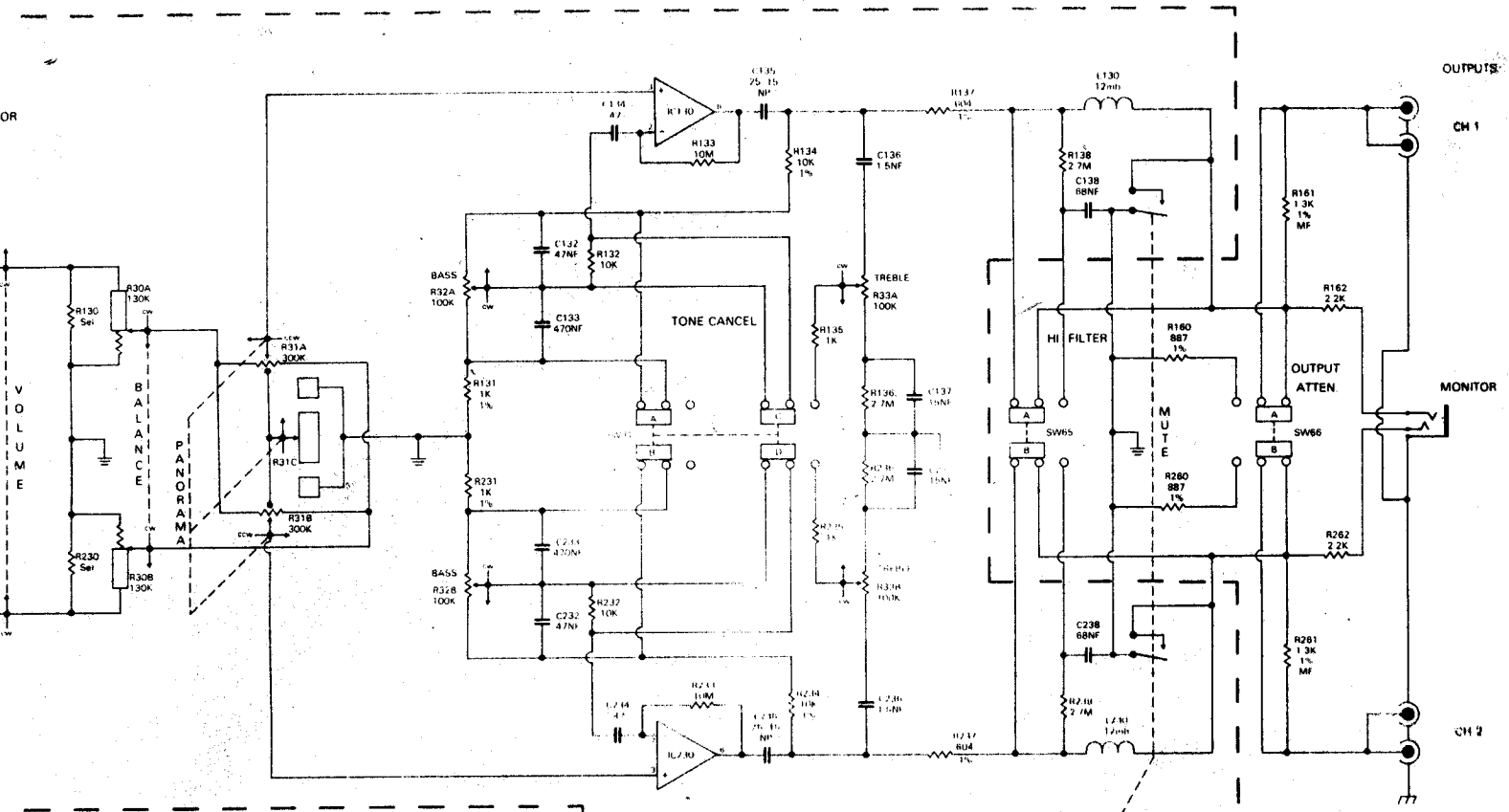

SUPPLY SHOWN CONNECTED FOR 120VAC.
 FOR OPERATION AT OTHER LINE VOLTAGES
 SEE LINE VOLTAGE CONVERSION
 INSTRUCTIONS IN THE MANUAL.

 **CROWN IC 150A**

STARTS S/N IC-18801

NEW

MI-262A

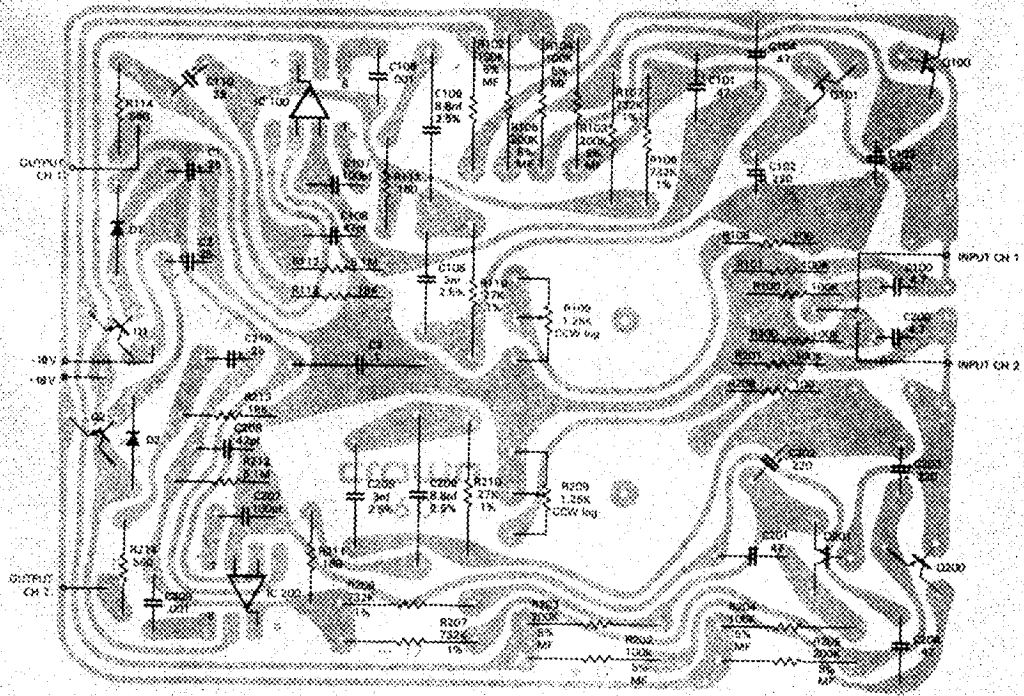
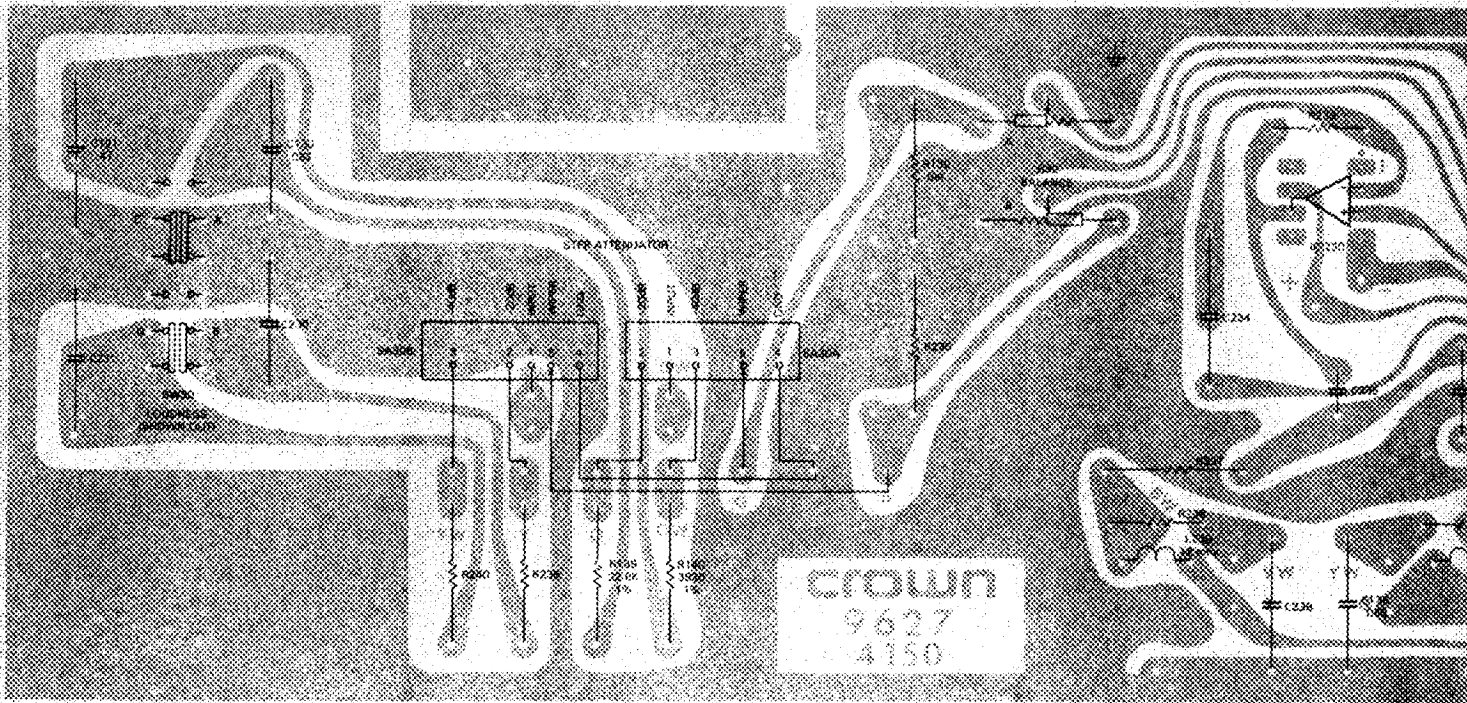

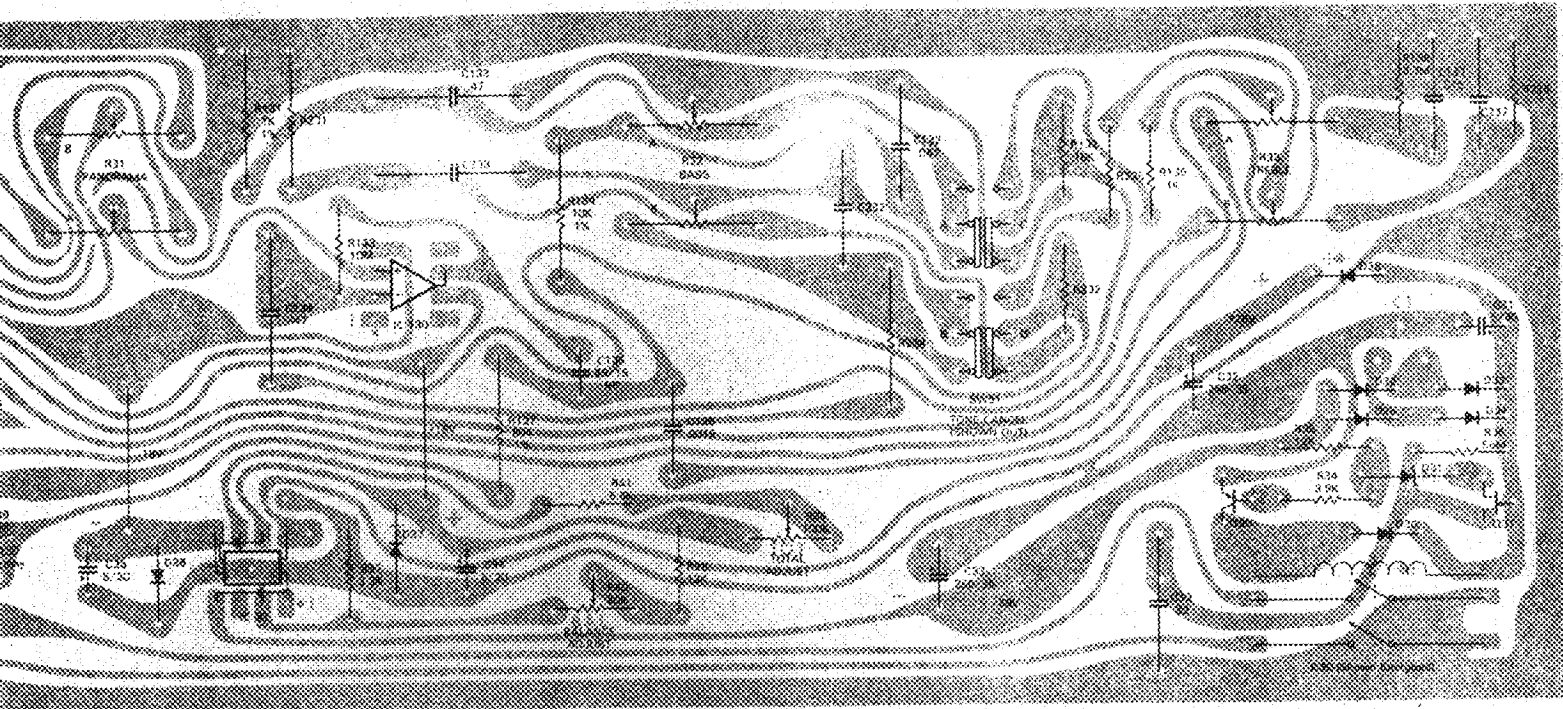

NOTES:

- THIS BOARD #9627 (4150) STARTS S/N 18401, AND APPLIES TO SCHEMATICS MI-262 AND MI-262A.
- PHONO BOARD #9607 STARTS S/N 17201 AND APPLIES TO SCHEMATICS MI-262 AND MI-262A.
- ALL RESISTORS IN OHMS, ALL CAPACITORS IN MFD UNLESS OTHERWISE INDICATED.
- VALUES GIVEN FOR LEFT CHANNEL ONLY; RIGHT CHANNEL IDENTICAL.
- FOIL SIDE SHOWN.
- COMPONENTS COMMON TO BOTH CHANNELS ARE NUMBERED 30-59. COMPONENT NUMBERS PRECEDED BY ONE ARE LEFT CHANNEL; BY TWO, RIGHT CHANNEL.

SPECIFICATIONS IC 150

FREQUENCY RESPONSE	Hi-level: ± 0.6 dB 3Hz-100KHz with hi-impedance load, ± 0.1 dB 10Hz-20KHz with IHF load; Phono: ± 0.5 dB of RIAA
PHASE RESPONSE	Hi-level: typically $+1^\circ$ to -12° 20Hz-20KHz with IHF load; Phono: typically $\pm 5^\circ$ 20Hz-20KHz additional phase shift
HUM AND NOISE	20Hz-20KHz inputs shorted; Hi-level: 95dB below rated output (typically 105dB with IHF "A" weighted measurement); Phono: 85dB below 10mV input (typically 0.3 μ V input noise)
DISTORTION IM	Less than .002% at rated output with IHF load (typically under 0.001%)
DISTORTION THD	Less than .0005% @ 1KHz, max. .05% 20Hz-20KHz at rated output with IHF load
INPUTS	Six hi-level inputs (1 tuner, 3 auxiliary, 2 tape), two equalized phonos
INPUT GAIN & IMPEDANCE	Hi-level: 20.8dB ± 0.2 dB, 100K ohms nominal (25K ohms volume max.); Phono: 50-70dB (adjustable) 47K ohms. Sensitivity: < 1mV @ 1KHz for rated output at maximum gain
PHONO INPUT OVERLOAD	33-330mV at 1KHz, depending on gain (>100mV when set to 60dB total preamp gain)
MAIN OUTPUTS	12V maximum before overload, 2.5V rated, 600 ohms output impedance. Switched 0dB to -10dB pad affects both sets of outputs
PHONO OUTPUT & IMPEDANCE	(Available at tape out jacks with input selector in phono) 600 ohms with typical maximum output of 11V RMS at 1KHz into hi-impedance load
MONITOR OUTPUT	Stereo, 3 circuit $\frac{1}{4}$ " phone output, ahead of 0dB to -10dB pad; output impedance 2.2K ohms each channel
VOLUME CONTROL	Precision switched attenuator of 58dB (and off) dynamic range with calibrated tracking within ± 0.2 dB
LOUDNESS COMPENSATION	New wide-range design for excellent simulation of I.S.O. curves down to 60 phons; with exclusive dual R/C bass-boost coordinated with volume attenuator
PANORAMA CONTROL	Unique, continuously-variable control for infinite adjustment from stereo to mono to stereo-reverse; replaces conventional stereo-mode switches and blend controls with an intuitive control of stereo spatial dimension
TONE CONTROLS	Continuously variable ± 15 dB at 30Hz and 15KHz, cancel switch bypasses independent bass and treble control settings to give instant true-flat response in both channels
MUTING	Uses reed relay – removes turn-on transients from IC-150A output, thus protecting speakers
FILTERS	Rumble: -3dB at 24Hz with 6dB per-octave cut-off (volume attenuator at -20), Scratch: -3dB at 5KHz with 12dB-per-octave cut-off
AC OUTLETS	Five switched with 25A switch, one unswitched
POWER REQUIREMENTS	About 2 watts at 120v or 240v 50-400Hz AC
SEMICONDUCTOR COMPLEMENT	Five integrated circuits (equivalent to 89 bipolar transistors, 3 zeners, 12 diodes and 25 FETS) for a total of 96 bipolar transistors, 26 FETS, 4 zeners and 22 diodes
DIMENSIONS	5 $\frac{1}{4}$ " H x 17" W; 8 $\frac{1}{8}$ " behind panel
WEIGHT	10 lbs., with walnut cabinet 20 lbs.

Schematic Designation	Description	Crown Part #	Other Information
	MAIN MODULE	41681	
	Main PC Board	9627	
	Switches		
SW30A,B,C,D SW31A,B,C,D	4 PDT Latching PB	3226	Loudness Control Tone Cancel
	Integrated Circuits		
IC 130, 230	LF 356H FET-Op Amp	4127	
IC 30	RC 4195	3825	
	Relay		
K30	5K ohms, DPDT, NC, reed	3496	
	Coil		
L130, 230	12 mhy	1661	
	Diodes		
D30, 32 D33,34 D35,36	1N4148	3181	
D31	IN961B, 10V, zener	3549	
D37,38	IN4003	2851	
	Transistors		
Q30	2N3859A, selected	2961	
Q31	2N5459, NCH, JFET	3053	
	Capacitors		
C130, 230	.082 MF 100V	4133	
C131,231 C133,233 C134,234	.47 MF 100V	4119	
C132, 232	.047 MF 200V mylar	3978	
C135, 235	25 MF 15V NP vertical	3186	
C136,236	.0015 MF 200V filmatic	3089	
C137,237	.015 MF 200V filmatic	3288	
C138,238	.068 MF 200V filmatic	3190	
C30	.22 MF 100V filmatic	3218	
C31, 34,35	5 MF 30V vertical	4026	
C32,33	250 MF 35V vertical	3787	