

MACRO
REFERENCE™

POWER AMPLIFIER

SERVICE MANUAL

CROWN INTERNATIONAL, INC.

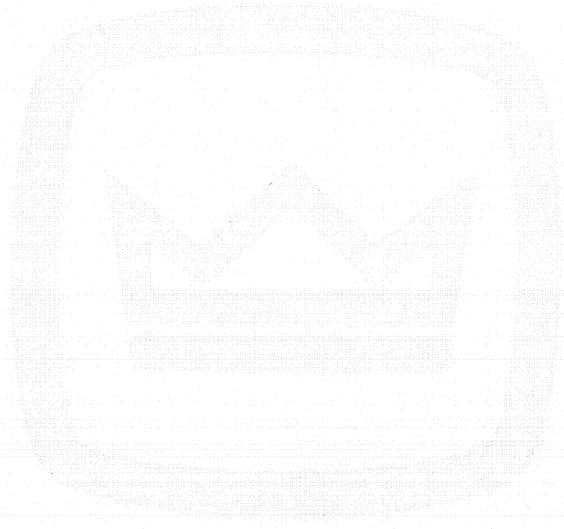

INDEX
REFERENCE
POWER APPLIERS
SERVICE MANUAL

Copyright © 1998

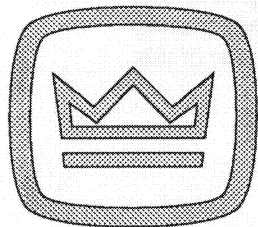

CROWN®

DISTRIBUTED IN NORTH AMERICA AS CROWN. EXPORTED AS AMCRON.

MACRO
REFERENCE™

POWER AMPLIFIER

SERVICE MANUAL

©1992 by CROWN INTERNATIONAL, INC.

Mailing Address:
P.O. Box 1000
Elkhart, IN 46515-1000

Shipping Address:
57620 C.R. 105
Elkhart, IN 46517-4095

Crown®, *IOC®*, *IQ System®*, *Multi•Mode®*, *ODEP®* and *P.I.P.®* are registered trademarks of Crown International, Inc. *Grounded Bridge™* and *Macro Reference™* are trademarks of Crown International, Inc.

The information furnished in this manual does not include all of the details of design, production, or variations of the equipment. Nor does it cover every possible situation which may arise during installation, operation or maintenance. If you need special assistance, beyond the scope of this manual, please contact the Crown International Customer Service Department.

Crown International, Inc.

Shipping:

57620 C.R. 105

Elkhart, Indiana 46517-4095

Mailing:

P.O. Box 1000

Elkhart, Indiana 46515-1000

Phone: (219) 294-8200

(800) 342-6939

Fax: (219) 294-8301

WARNING

**TO PREVENT SHOCK OR FIRE HAZARD,
DO NOT EXPOSE TO RAIN OR MOISTURE!**

CAUTION

**TO PREVENT SHOCK DO NOT USE THE POLARIZED AC
PLUG OF THIS UNIT WITH AN UNPOLARIZED EXTENSION
CORD, RECEPTACLE OR OTHER OUTLET WHERE THE
BLADES CANNOT BE FULLY INSERTED.**

ATTENTION

**POUR PREVENIR LES CHOCS ELECTRIQUES NE PAS
UTILISER CETTE FICHE POLARISEE AVEC UN
PROLONGATEUR. UNE PRISE DE COURANT OU UNE AUTRIE
SORTIE DE COURANT, SAUF SI LES LAMES PEUVENT ETRE
INSEREES A FOND SANS EN LAISSER AUCUNE PARTIE A
DECOUVERT.**

Table of Contents

1 Introduction	1-1	Parts
1.1 The Macro Reference	1-1	General Information
1.2 Warranty	1-2	Standard and Special Parts
2 Maintenance	2-1	Ordering Parts
2.1 Introduction	2-1	Shipment
2.2 Basic Troubleshooting	2-1	Terms
2.2.1 Establishing Problem		7 Exploded View Drawings
2.2.2 Visual Inspection		7-1
2.3 Troubleshooting	2-1	8 Module Artwork
2.3.1 Identifying Symptoms	2-2	8-1
2.3.2 Electrical Checkout and Adjustment Procedures	2-2	
3 Voltage Conversion	3-1	
4 Circuit Theory	4-1	
4.1 Overview	4-1	
4.2 Circuit Theory	4-1	
4.2.1 Stereo Operation	4-1	
4.2.2 Bridge-Mono Operation	4-2	
4.2.3 Parallel Mono Operation	4-2	
4.3 Control Circuitry	4-2	
4.3.1 Low Frequency Protection	4-2	
4.3.2 Common Mode Detector (High Side of Bridge)	4-2	
4.3.3 Common Mode Detector (Low Side of Bridge)	4-3	
4.3.4 Over Voltage Protection	4-3	
4.3.5 Fan Control	4-3	
4.4 Display Circuitry	4-3	
4.4.1 IOC	4-3	
4.4.2 ODEP	4-3	
4.4.3 Signal Indication	4-3	
5 Specifications	5-1	
5.1 Performance	5-1	
5.2 Power	5-1	
5.3 Controls	5-1	
5.4 Indicators	5-1	
5.5 Input/Output	5-1	
5.6 Protection	5-2	
5.7 Construction	5-2	
6 Schematics	6-1	

List of Illustrations

Fig. 1.1 Macro Reference	1-1
Fig. 2.1 Bridged MONO	2-2
Fig. 2.2 Differentiated RC Circuit	2-2
Fig. 2.3 Differentiated Square Wave	2-2
Fig. 2.4 10kHz Square Wave	2-2
Fig. 2.5 Inductive Load	2-2
Fig. 2.6 ODEP Protection	2-2
Fig. 3.1 Transformer Wiring Diagram	3-1
Fig. 3.2 Line Voltage Chart	3-2
Fig. 6.1 Amplifier Interconnection Chart	6-1
Fig. 7.1 Chassis Assembly (Top)	7-2
Fig. 7.2 Chassis Assembly (Bottom)	7-4
Fig. 7.3 Capacitor Assembly	7-6
Fig. 7.4 Front Panel Assembly	7-7
Fig. 7.5 Heat Sink Assembly	7-9
Fig. 7.6 Driver Transistor Assembly	7-10
Fig. 7.7 P.I.P. Cage Assembly	7-11
Fig. 7.8 Back Panel Assembly	7-12
Fig. 7.9 Thermal Sensor Mounting	7-13
Fig. 7.10 Wiring Diagram (Top)	7-14
Fig. 7.11 Wiring Diagram (Bottom)	7-15
Fig. 8.1 Control Module (Q42834-4)	8-2
Fig. 8.2 Display Module (Q42835-1)	8-8
Fig. 8.3 Output Module (Q42822-9)	8-16
Fig. 8.4 Output Module (Q42941-7)	8-16
Fig. 8.5 Main Module (Q42837-7)	8-22

PART I

Technical Information

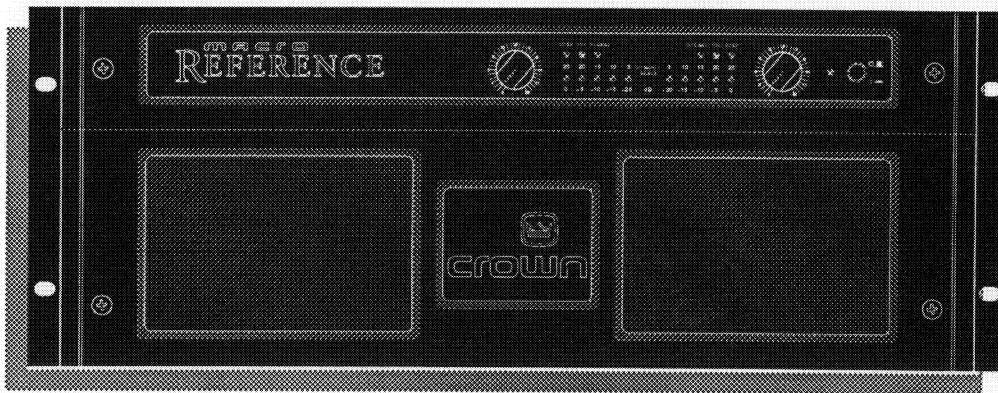

Fig. 1.1 Macro Reference

1 Introduction

This manual contains service information on the Crown Macro Reference power amplifier. It is designed to be used in conjunction with the Macro Reference Instruction Manual. However, some important information is duplicated in this Service Manual in case the Instruction Manual is not readily available.

NOTE: THE INFORMATION IN THIS MANUAL IS INTENDED FOR USE BY AN EXPERIENCED TECHNICIAN ONLY!

1.1 The Macro Reference

The Macro Reference amplifier is a compact, audio power amplifier designed for professional use. Providing high power amplification from 20Hz-20KHz with minimum distortion, the unit features balanced 1/4" phone and XLR inputs, bridged and parallel monophonic capability and a means for isolating signal shield ground from circuit ground.

1.2 Warranty

Each Instruction Manual contains basic policies as related to the customer. However, under questionable circumstances, please contact the Technical Service Department or Director of Customer Service at:

Crown International, Inc.
 Shipping:
 57620 C.R. 105
 Elkhart, Indiana 46517-4095
 Mailing:
 P.O. Box 1000
 Elkhart, Indiana 46515-1000
 Phone: (219) 294-8200
 (800) 342-6939
 Fax: (219) 294-8301
 BBS: (219) 294-8284

2 MAINTENANCE

2.1 Introduction

Section 4 contains technical information required to effectively and efficiently service and repair the Crown Macro Reference. Included are disassembly and reassembly procedures, required test equipment lists, checkout procedures and basic troubleshooting tips.

This information is intended for use by an *experienced* technician only!

Use this information in conjunction with the Instruction Manual, schematic/board layout diagrams, parts lists and exploded view drawings (the latter located in Sections 6, 7 and 8 of this manual).

2.2 Basic Troubleshooting

As is well know, time is an important factor in providing efficient service repair. Therefore, several time-saving troubleshooting steps are listed below. These hints may or may not already be implemented in your service work. If not, you may wish to experiment with them in order to help improve your efficiency. After all, time is money!

2.2.1. Establishing Problems

User complaints about defective operation may not always be clear or simple. Furthermore, the trouble the user has experienced may be due to the system and not the unit itself. If possible, talk to the user about this problem. This will usually be simpler than trying to understand written complaints. A first hand account of the problem can help in:

1. Getting the problem to re-occur on the service bench.
2. Getting an understanding of the probable cause. Some troubles will be obvious upon visual inspection. When the trouble (or its symptoms) is not so obvious ask:
 - a) Exactly what was the problem: how was it noticeable?
 - b) How was the unit being used?
 - c) Has the system as a whole been carefully examined for possible external problems?
 - d) How long had the unit been operating when the problem occurred? Was it heat related?

If the user is unavailable or unable to explain the trouble the next step is a thorough visual inspection.

2.2.2. Visual Inspection

A good visual inspection may often save hours of tedious troubleshooting. Make a habit of proceeding in an orderly manner to insure that no vital part of the following procedure is omitted. The visual inspection can be performed in 10 to 15 minutes. It is recommended both as a preventative maintenance procedure and also for its value in determining cause of malfunction

1. Check that all external screws are tight and that none are missing.
2. Check all fuses/circuit breakers.
3. Check for smooth and proper operation of switches, etc.
4. Inspect line cord for possible damage to cap, jacket and conductors.
5. Remove protective covers.
6. Check that all attaching parts for internal circuits are tight and that none are missing.
7. Inspect all wiring for charred insulation, or discoloration as evidence of previous overheating.
8. Check that all electrical connections are secure. This includes wire terminals, screw and stud type terminals, and all soldered connections.
9. Check for obvious destruction of internal structural parts. Distortion in any of these parts could mean that the unit has been dropped or subjected to severe shock.

2.3 Troubleshooting

The three steps to effective troubleshooting and repair were mentioned earlier. They can be summarized in the three following questions: What is the problem (effect)? What is causing the problem (cause)? What can be done to eliminate the cause (repair)? The purpose of this section is to help you answer these questions in an orderly manner.

Finding and fixing the problem(s) is not the end of maintenance. The final step is to thoroughly test the amplifier to be certain that it meets the factory specifications after it has been repaired. The test procedures in section 2.5.2 will help you do this as well as aid you in locating the cause of problem(s).

2.3.1 Identifying Symptoms

Why was the amplifier brought in for repair? Can you get it to malfunction again? (Some problems can be intermittent and difficult to find.) If you don't observe anything wrong with the amplifier, tactfully inquire how the owner used it and try to determine if it was misused or some other component in their system could have been at fault.

2.3.2 Macro Reference Electrical Checkout and Adjustment Procedures

The following instructions outline an orderly checkout and troubleshooting procedure. The purpose and arrangement

of this procedure is to determine the cause of the trouble as quickly as possible; leading to a detection of which component part(s) must be replaced or repaired.

WARNING!!

Most adjustments are made with protective covers removed. This means prior to any non-ac-powered testing, discharge all power capacitors. Also, use extreme caution while making any internal adjustments when the unit is powered.

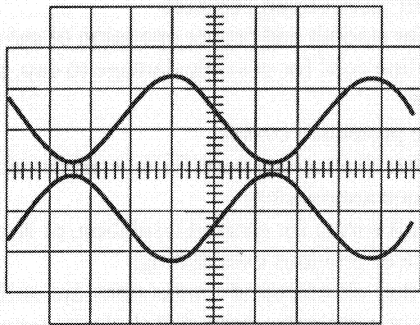

Fig. 2.1 Bridged MONO

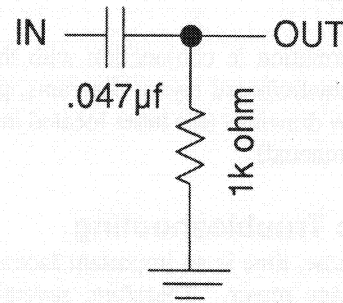

Fig. 2.2 Differentiated RC Circuit

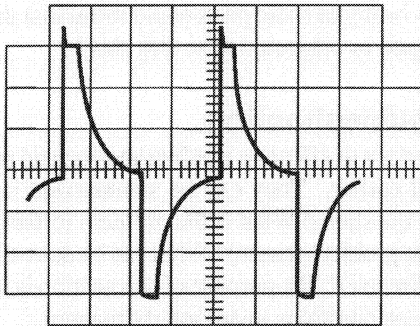

Fig. 2.3 Differentiated Square Wave

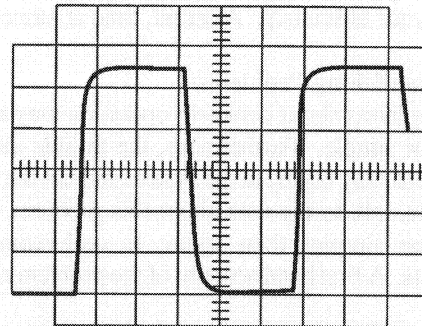

Fig. 2.4 10kHz Square Wave

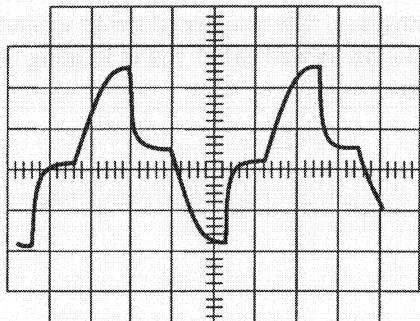

Fig. 2.5 Inductive Load

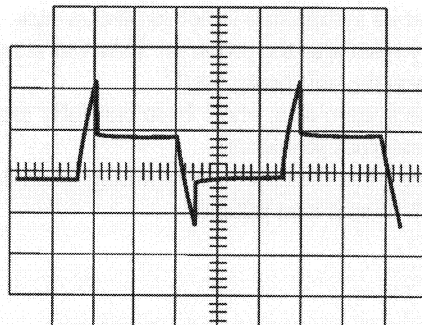

Fig. 2.6 ODEP Protection

Type of Test or Adjustment	Input Signal Characteristics	Comments
1. Bias	None	<p>With a quiescent power of less than 90 watts measure the voltage across R302 and R402. The bias voltage should equal .350 VDC + .05 V - .000 V. If the bias voltage needs to be adjusted, adjust R326 and R426 for the correct bias voltages. Next measure the voltage across R321 and R421. This voltage should equal .35 VDC \pm .025 V. If the bias voltage needs to be adjusted, adjust R323 and R423 for the correct bias voltage.</p> <p>Check the voltage across R309, R409, R322 and R422 to make sure it is between .500 to .600 VDC.</p>
2. DC Output Offset	None	<p>With the input level controls (R100 and R200) turned fully clockwise, the DC offset for both channels should be no more than +/- 10 millivolts. Note: There is no output offset adjustments for the Macro-Reference.</p>
3. O.D.E.P Null	None	<p>With the amplifier cool pin 1 of S100/S200, should measure -10VDC (+/- .1V). If needed adjust R121 and R221 for the correct voltages. Pin 3 of S100/S200, should measure +11.1VDC +/- .1V. If needed adjust R132 and R232 for the correct voltages.</p>
4. Input C.M.R.	1kHz sq. wave; .775V	<p>Using a balanced 1/4 inch input jack with the tip and ring shorted together insert a 5Vp-p 1 kHz square wave signal into the amplifier input. For amplifiers with 2.2 volt sensitivity use a 2.2 VAC signal. While monitoring the outputs of channel one and channel two with an oscilloscope adjust R512 and R612 for an output null.</p>
5. Monophonic	1kHz sine wave; .415V	<p>-Parallel Mono Tests With the stereo/mono switch in the parallel mono position insert a .775 VAC 1 kHz signal into channel one. There should be a two inphase signals present, equal in amplitude, at the outputs of channels one and two. Both of these signals will be controlled by channel one input level control. Switch the stereo/mono switch to stereo. There should be signal present only on channel one output.</p> <p>-Bridge Mono Tests With the stereo/mono switch in the bridge mono position, set the channel two input level control to full CCW. Insert a .775 VAC 1 kHz signal into channel one input. There should be signal present on both channel outputs, equal in amplitude, with channel two 180 degrees out of polarity from channel one (see Fig. 4.1 : page 4-8). Channel one input level control should control the output level for both channels. Return the amplifier to stereo operation.</p>

Type of Test or Adjustment	Input Signal Characteristics	Comments
		<p>THE FOLLOWING CHECKS ARE DONE BY USING A LOAD. PLEASE USE CAUTION AND FOLLOW THE CHECK OUT PROCEDURES CAREFULLY TO INSURE CORRECT RESULTS.</p> <p>NOTE: The following tests are done assuming that the amplifier is configured for .775 V input sensitivity. Input voltages will need to be greater if the amplifier is in the 26 dB gain position sensitivity.</p> <p>CAUTION: THE FOLLOWING TESTS WILL REQUIRE A RESISTIVE LOAD CAPABLE OF 1500 WATTS INTO TWO OHMS.</p>
6. Current Limit Tests	1kHz sq. wave; 1 ohm	<p>NOTE: The current limit tests require a differentiated square wave input. See Fig. 4.2 (page 4-8) for a circuit to create a differentiated square wave.</p> <p>On the channel under test insert a 1 kHz differentiated square wave. With a one ohm load on the output, monitor the output waveform with an oscilloscope. Slowly increase the input signal until the output signal starts to clip as shown in Fig. 4.3 (page 4-8). Current limiting should take place when the output reaches a 40 volt peak which would produce 40 amps of output current.</p>
7. 10 kHz Square Wave	10kHz sq. wave; 8 ohm	<p>With an 8 ohm load on each channel insert a 10 kHz square wave to produce a 20 VAC output (Fig. 4.4 : page 4-8). Observe the rise time of the signal which should be 13 volts per microsecond. The output waveform should be stable with no ringing. Some overshoot may occur with peak output voltages greater than 20 volts.</p>
8. 20 kHz Sine Wave	20kHz sine wave; 8 ohm	<p>With an 8 ohm load on each channel insert a 20 kHz sine wave on both inputs. Vary the amplitude of the input signal and observe where clipping takes place. The amplifier should produce at least 73 VAC on the output before clipping occurs.</p>
9. 1 kHz Power Checks	<p>1kHz sine wave; 8 ohm</p> <p>1kHz sine wave; 4 ohm</p>	<p>With both channels operating, insert a 1 kHz signal into the inputs. Observe the following output voltages with the various output loads.</p> <p>8 Ohm Load Minimum output voltage before clipping should be 78 VAC (760 watts).</p> <p>4 Ohm Load Minimum output voltage before clipping should be 68.1 VAC (1160 watts).</p>

Type of Test or Adjustment	Input Signal Characteristics	Comments
	1kHz sine wave; 2 ohm	2 Ohm Load Minimum output voltage before clipping should be 54 VAC (1458 watts).
10 Inductive Load	1kHz sine wave; .415V;159µh coil	Insert a 1 kHz sine wave, .415 VAC into both channels and connect a 159 microhenries inductive load (paralleled with an 8 ohm resistor) on the output of each channel. Observe the output waveform (Fig. 4.5 : page 4-8).
11. ODEP Limiting	60Hz sine wave; .415V	For the following tests, the cooling fan blade must be removed to allow the heatsinks to heat up. With a 2 ohm load per channel, insert a .415 VAC, 60 Hz input signal to both channels. Allow the heatsinks to heat up until the ODEP protection circuit starts to limit the output signal. The waveform in Fig. 4.6 (page 4-8) should be observed. On the Macro-Reference check to see that the amber LED is not lit when ODEP is activated. Next configure the amp for parallel mono operation . With the input signal now present on channel one only, load channel one output with 8 ohms and channel two with 2 ohms. Observe that channel two ODEP protection circuit is limiting both channel one and channel two outputs. Next load channel one with 2 ohms and channel two with 8 ohms. Observe that channel one ODEP protection circuit is limiting both channel one and channel two outputs. Reinstall the cooling fan blade after this test has been completed.
12. I.M. Distortion	60Hz/7kHz (4:1 ratio); 8 ohm	Using a 60 Hz / 7 kHz input signal summed in a 4:1 ratio with 8 ohm loads on both channels measure the I.M. distortion at the rated output of 760 watts for each channel. Readings should be less than .05% from 28 milliwatts to 760 watts.
13. T.H.D.	20kHz sine wave; 8 ohm	Using a 20 kHz input signal with 8 ohm loads on both channels measure the T.H.D. distortion at the rated output of 666 watts (73 VAC) for each channel. The rated RMS sum total harmonic distortion should be less than .1% of the fundamental output voltage
14. Signal To Noise	Input sensitivity switch to 26 dB	With input jacks shorted insure that each channel has a signal-to-noise ratio greater than -120 dB below the rated power of 760 watts into 8 ohms. Be sure to use a 20 Hz to 20 kHz bandpass filter ahead of the voltmeter.
15. IOC® Operation	1kHz sine wave; 8 ohm	With no load on the amplifier apply a 1 VRMS, 1 kHz signal to the input of each channel. Note that the green LED is brightly lit to indicate clipping. Now turn the level down and note that the green LED dims to indicate normal signal presence. Check both channels.

Type of Test or Adjustment	Input Signal Characteristics	Comments												
16. Input Sensitivity	1kHz sine wave; .775 V	Adjust the input level controls (R100 and R200) fully CW and set the sensitivity switch (S3) to the 26dB gain position. With an input level of .775V at 1kHz amplifier output level should measurement 15.2 - 15.8 Vrms. Return sensitivity switch to .775 position. Output level should measure 76 - 79 Vrms.												
17. Display Calibration	1 KHz sine wave: Sensitivity switch in high gain (.775) position	<p>Level Verification: While viewing the amplifier upside down and from the front switch S-1 (on the display board) to the right or Level position. Apply a 1 KHz input signal to both channels. Slowly increase the input amplitude until the -10dB LED begins to pulse. Adjust R78 on the display board until the channel 1 and channel 2 indicators pulse at the same frequency. Indicators should illuminate within the tolerances specified below:</p> <table data-bbox="862 884 1377 1136"> <thead> <tr> <th><u>LEVEL INDICATOR</u></th> <th><u>OUTPUT LEVELS (RMS) REQUIRED TO ILLUMINATE</u></th> </tr> </thead> <tbody> <tr> <td>-20 dB</td> <td>6.95 - 8.75</td> </tr> <tr> <td>-15 dB</td> <td>12.36 - 15.56</td> </tr> <tr> <td>-10 dB</td> <td>21.9 - 27.67</td> </tr> <tr> <td>-5 dB</td> <td>39.09 - 49.21</td> </tr> <tr> <td>0 dB</td> <td>69.51 - 87.51</td> </tr> </tbody> </table>	<u>LEVEL INDICATOR</u>	<u>OUTPUT LEVELS (RMS) REQUIRED TO ILLUMINATE</u>	-20 dB	6.95 - 8.75	-15 dB	12.36 - 15.56	-10 dB	21.9 - 27.67	-5 dB	39.09 - 49.21	0 dB	69.51 - 87.51
<u>LEVEL INDICATOR</u>	<u>OUTPUT LEVELS (RMS) REQUIRED TO ILLUMINATE</u>													
-20 dB	6.95 - 8.75													
-15 dB	12.36 - 15.56													
-10 dB	21.9 - 27.67													
-5 dB	39.09 - 49.21													
0 dB	69.51 - 87.51													

3 Voltage Conversion

The Macro Reference can be wired for 100VAC, 120VAC, 200VAC, 220VAC or 240VAC operation. This is made possible by use of a multitap transformer for the high energy power supplies. Follow the table shown with the schematic, and the drawing below:

CAUTION: Because there is a risk of electric shock, only a competent technician should attempt to alter the line voltage configuration.

1. Remove the top cover of the Macro Reference (held on by 8 screws).

2. With the front panel toward you, locate the control module where all pwr connections are made to the power transformers.
3. Make the appropriate change in jumpers for the desired operating voltage. See Fig. 3.1 and Fig. 3.2.
4. Replace the 30 amp circuit breaker with a 20 circuit breaker, for all connections 200V and above.
5. Change the line cord tag to read the correct voltage.

Note: Use only a 30 amp circuit breaker for 100VAC or 120VAC operation. Use only a 20 amp circuit breaker for 200VAC, 220VAC or 240VAC operation.

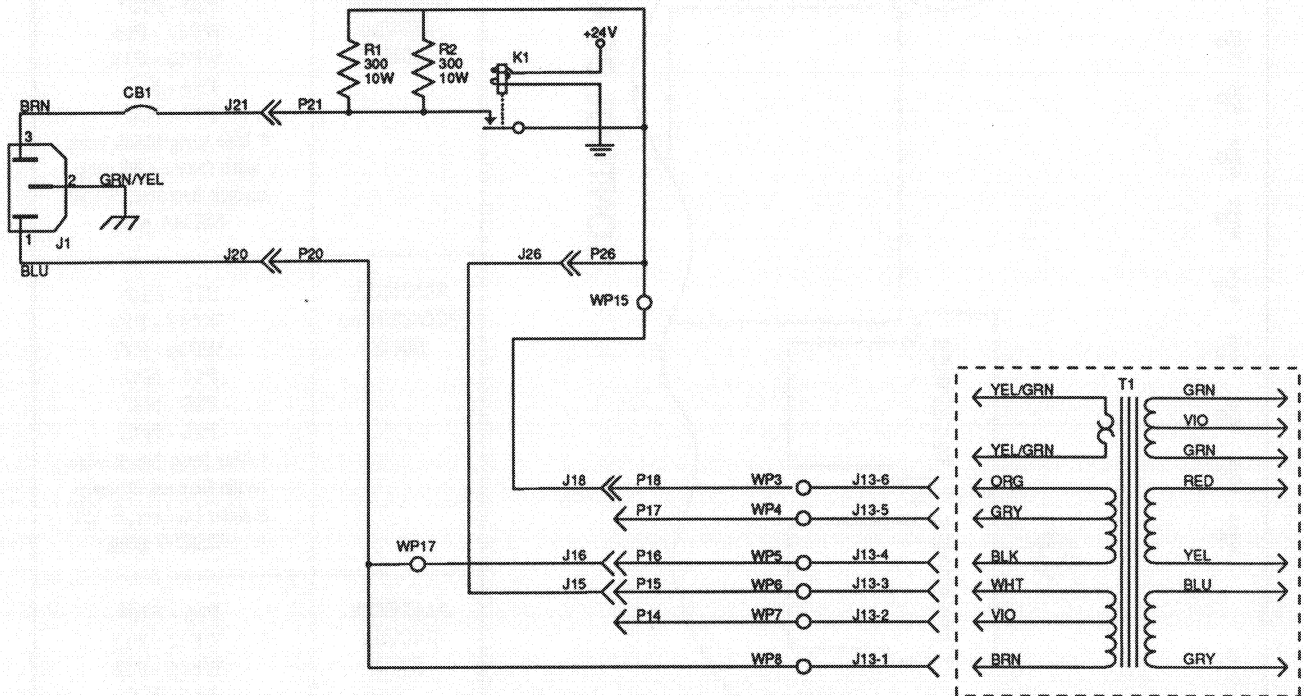

Fig. 3.1 Macro Reference AC Primary Diagram

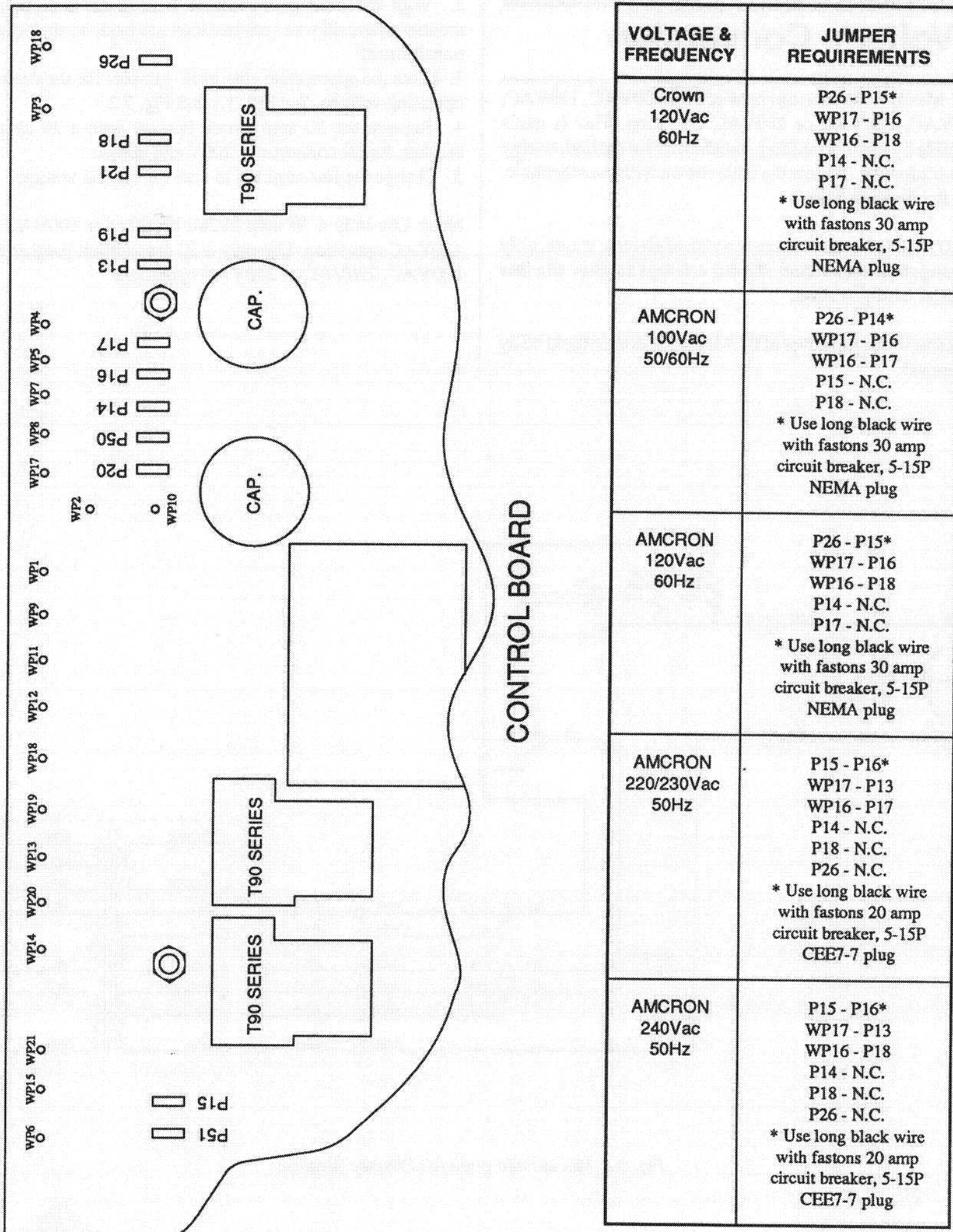

Fig. 3.2 Macro Reference Line Voltage Change Chart

4 Circuit Theory

4.1 Overview

The MR amplifier incorporates several new technological advancements including real-time computer simulation, low-stress output stages, and an advanced heatsink embodiment. Extra circuitry is incorporated to limit temperature and current to safe levels—making it highly reliable and tolerant of faults. Unlike many lesser amplifiers, it can operate at its voltage and current limits without self-destructing.

Real-time computer simulation is used to create an analog of the junction temperature of the output transistors (herein referred to as the output devices). Current is limited only when the device temperature becomes excessive—and just by the minimum amount necessary. This patented approach maximizes the available output power and eliminates overheating—the major cause of device failure.

The topology used in the MR amplifier grounded output stages is called the “grounded bridge,” and makes full use of the power supply. This patented topology also provides peak-to-peak voltages available to the load that are twice the voltage the output devices are exposed to. The grounded bridge topology is ground-referenced. Composite devices are constructed to function as gigantic NPN and PNP devices, since the available currents exceed the limits of available devices. Each output stage has two of these composite NPN devices and two composite PNP devices.

The devices connected to the load are referred to as “high-side NPN and PNP” and the devices connected to ground are referred to as “low-side NPN and PNP.” Positive current is delivered to the load by increasing conductance simultaneously in the high-side NPN and low-side PNP stage, while decreasing conductance of the high-side PNP and low-side NPN in synchrony. The two channels may be used together to double the voltage (bridge-mono) or the current (parallel-mono) presented to the load. This feature gives the user flexibility in maximizing the power available to the load.

A wide-bandwidth multiloop design is used for state-of-the-art compensation. This produces ideal behavior and results in ultra-low distortion values.

Aluminum extrusions have been widely used for heatsinks in power amplifiers due to their low cost and reasonable performance. However, measured on a watts per pound or watts per volume basis, the extrusion technology doesn't

perform nearly as well as the heatsink technology developed for the MR power amplifier.

Our heatsinks are fabricated from custom convoluted fin stock that provides an extremely high ratio of area to volume, or area to weight. All power devices are mounted directly to massive heat spreaders that are electrically hot. Making the heat spreaders electrically hot allows improved thermal performance by eliminating the insulating interface underneath the power devices. The chassis itself is used as part of the thermal circuit, and this maximizes utilization of the available resources.

4.2 Circuit Theory

Power is provided by low-field toroidal power transformer T1. The secondaries of T1 are full-wave rectified by D22 D23, D1-4 and filtered by large computer-grade capacitors. A thermal switch embedded in the transformer protects it from overheating.

Monolithic regulators provide a regulated ± 15 volts.

4.2.1 Stereo Operation

For simplicity, the discussion of stereo operation will refer to channel one only. Mono operations will be discussed later.

Please refer to the schematics provided at the back of this manual.

The input signal at the phone jack passes directly into the balanced gain stage (U104-A). Use of a P.I.P. module for input signal causes the input signal to pass through the P.I.P. and then to the balanced gain stage. The balanced gain stage (U104-A) causes balanced-to-single-ended conversion to take place using a difference amplifier. From there, gain is controlled with the front-panel level controls and the internal input sensitivity switch. (The input sensitivity switch is located through the P.I.P. opening in the rear panel. See figure 4.2.) The error amp (U104-C) amplifies the difference between the output signal and the input signal from the gain stage, and drives the voltage-translator stage.

The voltage-translator stage channels the signal to the Last Voltage Amplifiers (LVA), depending on the signal polarity, from the error amp U104-C. The +LVA (Q105) and the -LVA (Q110), with their push-pull effect through the bias servo Q318, drive the fully complementary output stage.

The bias servo Q318 is thermally coupled to the heat sink, and sets the quiescent bias current in the output stage to lower the distortion in the crossover region of the output signal.

With the voltage swing provided by the LVAs, the signal then gains current amplification through the triple Darlington emitter-follower output stage.

The bridge-balanced circuit (U104-D) receives a signal from the output of the amplifier, and differences it with the signal at the VCC supply. The bridge-balanced circuit then develops a voltage to drive the bridge-balanced output stage. This results in the VCC supply having exactly one-half of the output voltage added to their quiescent voltage. D309, D310, D311 and a trimmer resistor in parallel with D312 set the quiescent current point for the bridge-balanced output stage.

The protection mechanisms that affect the signal path are implemented to protect the amplifier under real-world conditions. These conditions are high instantaneous current, excessive temperature, and operation of the output devices outside safe conditions.

Q107 and Q108 act as a conventional current limiter, sensing current in the output stage. When current at any one instant exceeds the design criteria, the limiters attenuate the drive from the LVAs, thus limiting current in the output stage to a safe level.

To further protect the output stages, a specially developed ODEP circuit is used (Output Device Emulator Protection). It produces an analog output proportional to the always-changing safe operating area margin of the output transistor. This output controls the translator stage previously mentioned, removing any further drive that may exceed the safe operating area of the output stage.

Thermal sensor S100 gives the ODEP circuits vital information on the operating temperature of the heat sink on which the output devices are mounted.

Should the amplifier fail in such a way that would cause DC across the output lead, the DC protection circuit senses this and shuts down the power supply until the DC is removed.

4.2.2 Bridge-Mono Operation

By setting the rear panel Stereo-Mono switch to BRIDGE-MONO, the user can convert the MR into a bridge-mono amplifier. With a signal applied to the Channel 1 input jack, and the load between the red banana posts on the back panel, a double-voltage output occurs.

The Channel 1 output feeds the Channel 2 error amp U204-C. Since there is a net inversion, Channel 2 output is opposite polarity of Channel 1. This produces twice as much voltage

across the load. Each of the channel's protection mechanisms work independently if a fault occurs.

4.2.3 Parallel-Mono Operation

With the Stereo-Mono switch set to PARALLEL-MONO, the output of Channel 2 is paralleled with that of Channel 1. A suitable high-current-handling jumper must be connected across the red banana posts to gain the benefits of this mode of operation.

The signal path for Channel 1 is the same as previously discussed, except that Channel 1 also drives the output stage of Channel 2. The balanced input, error amp, translators, and LVAs of Channel 2 are disconnected and no longer control the Channel 2 output stage. The Channel 2 output stage and protection mechanisms are also coupled through S1 and function as one.

In PARALLEL-MONO mode, twice the current of one channel alone can be obtained. Since the ODEP circuit of Channel 2 is coupled through S1, this gives added protection if a fault occurs in the Channel 2 output stage. The ODEP circuit of Channel 2 will limit the output of both output stages by removing the drive from the Channel 1 translator stages.

4.3 Control Circuitry

The channel one relay, K2, is energized by PNP transistor Q1. The control voltage needed to bias on Q1 comes from pin 13 of U102D and [UOIC]. On initial turn on the capacitor C110 begins to charge. This charging action brings the inverting input (pin 10) low. This causes a high output on pin 13 of (U102D) and Q1 is held off (approximately 3 seconds). After C110 is charged Pin 10 is high causing U102D to change states placing a low on pin 13. This low turns on Q1 causing the relay K2 to turn on. There are four control mechanisms that can cause K2 to de-energize:

4.3.1 Low Frequency Protection

U102A and U102B are arranged as a window comparator with a window level of $\pm 10V$. During normal operation pins 1 and 2 are at a logic high allowing Q1 to remain on. R184, R184, C119 and C107 for a filter action that allows frequencies from below seven hertz down to DC to change the state of U102A and U102B. Any signal with a level above 10V and from seven hertz down to DC will cause U102A and U102B to switch states. This action ultimately will cause Q1 to Turn off de-energizing K2.

4.3.2 Common Mode Detector (High Side of Bridge)

U101C and U101D use as a window voltage through a resistor dropping network (R163 and R164) the amplifier

output waveform. This window voltage is found on pins 9 and 10. The high side of bridge current is sensed across R304 and R307. This voltage as related to current is placed, through resistor dropping networks onto the input pins 9 and 10. As common mode current increases the potential of pins 9 and 10 eventually will overcome the reference voltage set up by pins 8 and 11. When this output voltage window is exceeded the two comparator sections switch states and Q1 is ultimately switched off.

4.3.3 Common Mode Detector (Low Side of Bridge)

U101A and U101B form a window comparator circuit with a window of $\pm 4V$. Pins 7 (through R143) and 4 (through R144) receive a signal level that is related to the low side of bridge emitter current. When this level exceeds .4 volts, on both input pins (pin 4 and pin 7), the logic level of the two sections switch states from a normally low level to a logic high. This logic change results in the turning off of Q1 which de-energizes K2.

4.3.4 Over Voltage Protection

U1D serves as a window comparator for the purpose of over line voltage control. In the event the line voltage exceeds 10% (132VAC) the high energy power supplies are disabled. R7 and R8 form a resistor dropping network from the regulated +15V supply to ground. The voltage drop across R8 is 11.3VDC and serves as the window level and is applied to pin 10 (inverting input). With pin 10 in control of U1D pin 13 has a logic low which is placed across D13 and D14. This prevents conduction and allows Q1 to remain on which allows K2 to remain energized.

Resistors R3, R4, R5 and R6 serve as a resistor dropping network from the unregulated +24VDC supply to ground. As the line voltage increases the unregulated supply will become increasingly more negative. The voltage level on the wiper of R4 is applied to pin 11 (non-inverting input). When this level exceeds the window level of pin 10 the circuit switches states. This allows D13 and D14 to conduct placing a logic high on to the base of Q1. This, in turn, biases off Q1 and de-energizes K2.

4.3.5 Fan Control

The fan control signal is the ODEP waveform taken from the ODEP protection circuit. U1D is an inverting amplifier with a gain of three ($20 \log -(5.1M\Omega/1M\Omega + 510k\Omega)$). As the output transistors/heatsink increase in temperature the ODEP voltage level will drop from 11.1VDC to near 0VDC. The product of U1D will be an inversion of this ODEP protection voltage and multiplied by a times of three. Because of the dc bias, on pin 13 of U1D, the amplified signal begins at -15V and after complete ODEP limiting ends up at +15V. This initial

high negative voltage causes D5 to cut off. The inverting input on U1B, on the Control Module, being negative is inverted and biases off the opto-triac and in turn keeps the fan off. As the ODEP protection voltage decreases in dc value the voltage output of U1D on the display module will become progressively less negative and eventually becoming positive in polarity. As this fan control voltage becomes positive conduction of D5 will increase. As conduction of D5 increases the signal on pin 6 of U1B on the control module becomes less negative. The output of U1B on the control module eventually switches and the opto-triac is biased on. This in turn biases Q4 into conduction and allows the fan to begin turning.

A gating signal is placed across pin 7 of U1B on the control module. This gating signal is a product of U1A, Q3, R19 and the fan enable signal from the display module. C12 and R19 form an RC timing circuit that from the +15V supply begin to charge. U1A monitors the Line voltage wave form and is a 0V crossing detector. Everytime the line waveform crosses 0V Q3 is turned on and discharges C12. This develops a ramping type waveform. The higher positive portion of the waveform is used to turn off the opto-triac even when the fan control signal is of a value by itself to turn on the fan. The fan control current therefore has a duty cycle to it.

4.4 Display Circuitry

4.4.1 IOC

U3A and U3B serve as a voltage comparator with R13, R15 and R17 as the resistor dropping network. Pin 7 has a window level of +7V and pin 4 has a window of -7V. U3A and U3B have a logic high which turns off Q1 and the IOC LED E1. When the error signal from the error amp appears the $\pm 7V$ window is overcome and switches the state of U3A and U3B. Q1 then is biased on and the IOC LED E1 illuminates for the duration of the error signal.

4.4.2 ODEP

U5C on the display module is the current source for the ODEP LED E15. Under normal operating conditions U5C and D7 conduct allowing current to flow through the LED 15. As the fan control signal

4.4.3 Signal Indication

Incorporated on the display module of the Macro Reference amplifier are three modes of signal indication:

SPI (Signal Presence Indication)

U1A and U1B serve as a full wave rectifying network. On the output of U2B is the SPI LED E4 which illuminates anytime signal is present.

Dynamic Range/Signal Level Indication

With the switch S1 in the Dynamic position this rectified audio signal is placed on the inverting inputs of a sequence of window comparators. U3C, U3D, U5A, U5B and U5D serve as the current sources for the five Dynamic Range LEDs. This signal is rectified but unfiltered containing, therefore, the peak value of the audio waveform. R29, R31, R33, R35, R37 and R39 provide a resistor dropping network

for the inverting inputs to the Dynamic Range current sources. This same rectified signal is placed on the non-inverting inputs via the filtering function of C3. The signal applied to the non-inverting inputs is of an RMS value. With the non-inverting input receiving the RMS value and the inverting input receiving the peak value the output of each LED comparator is the dynamic range of the signal.

With the switch S1 in the Level position the peak signal is still placed on the inverting inputs of the comparator drivers. A small DC level is placed on all of the non-inverting inputs. The LED illumination is, in this mode, peak responding instead of signal Dynamic Range.