

**SCHEMATIC
DIAGRAM**

CRUMAR[®]

Musical Instruments

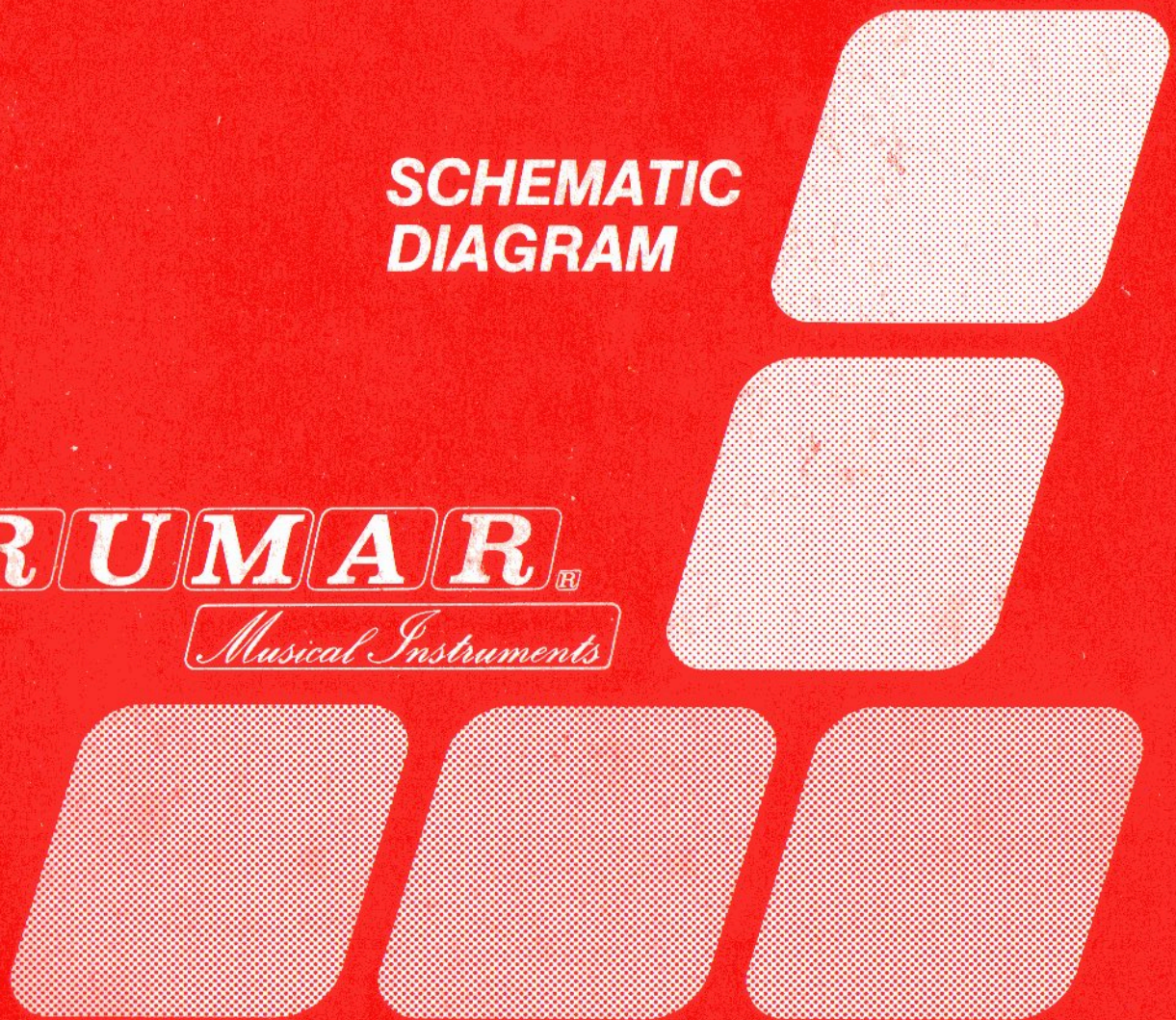

*mod.
multiman s*

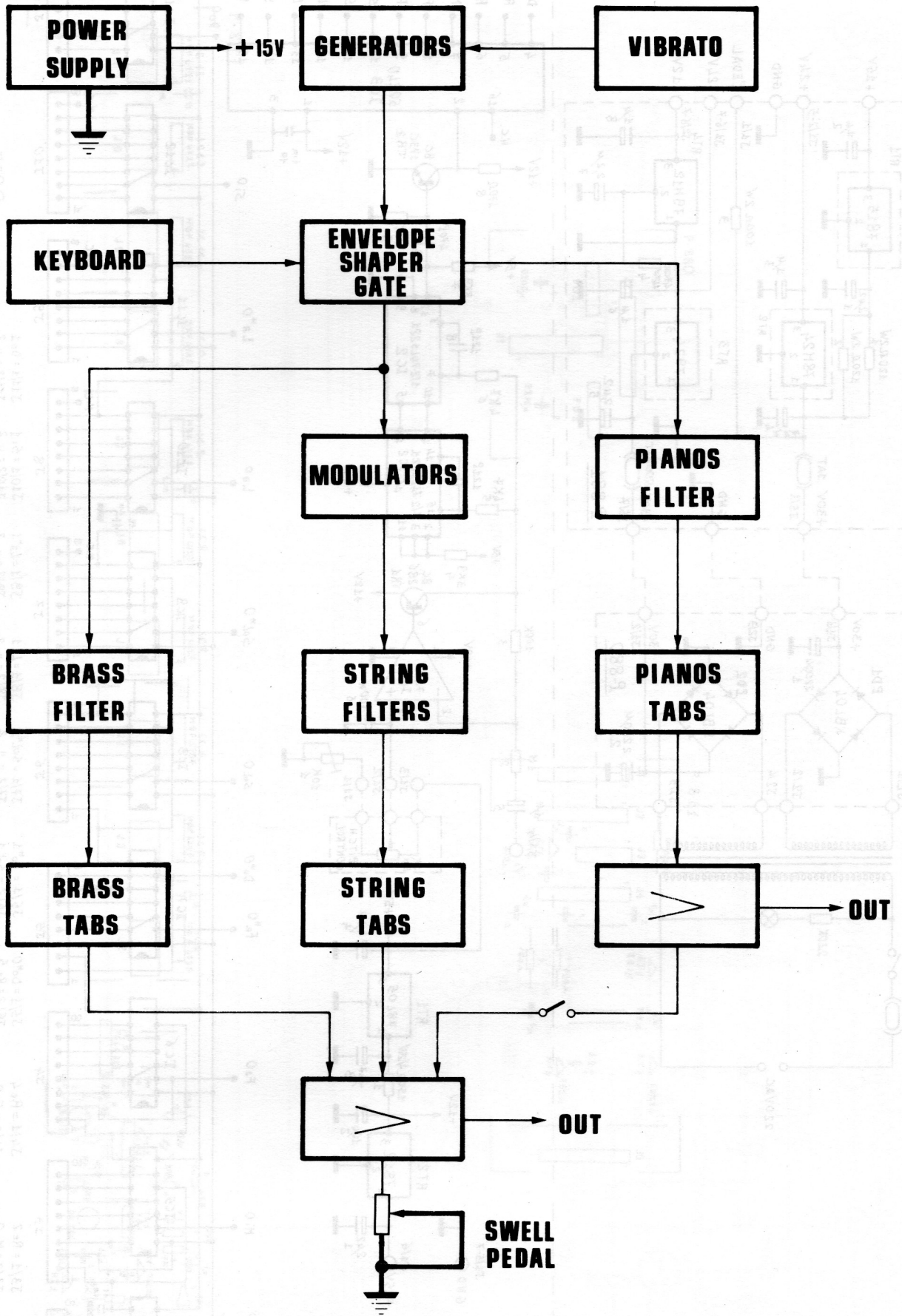

| | | | | |
|------------------|---------------------------------|--------------------------------|------|--|
| MODEL MULTIMAN-S | | REVISION | | |
| DATE | DRAWN BY <i>G. J. Seiter</i> | DESIGNED BY <i>R. Brain</i> | DATE | |

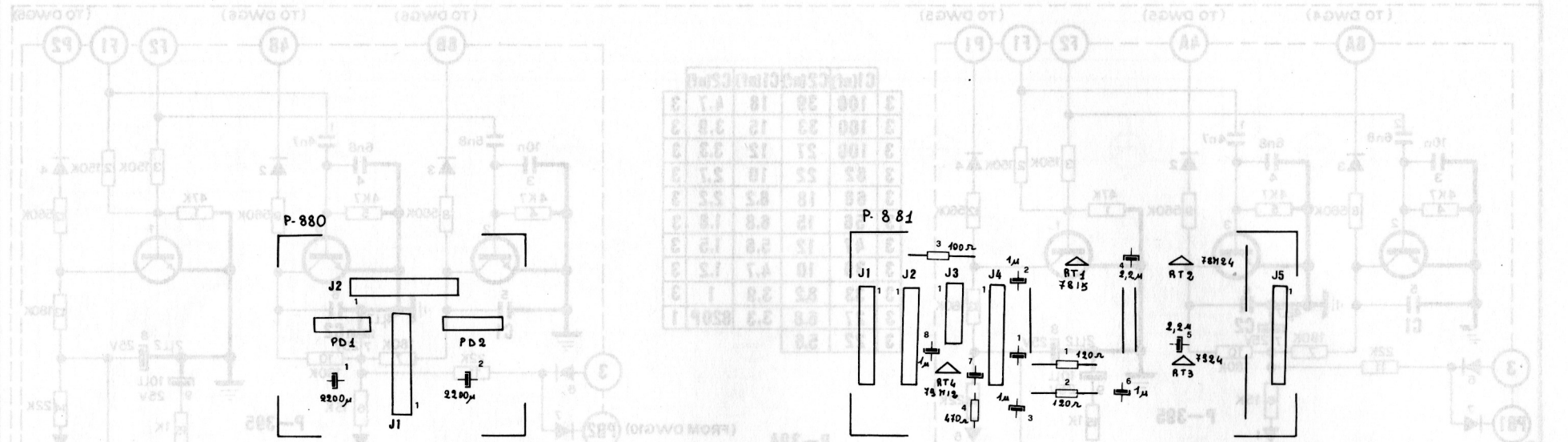

P-877

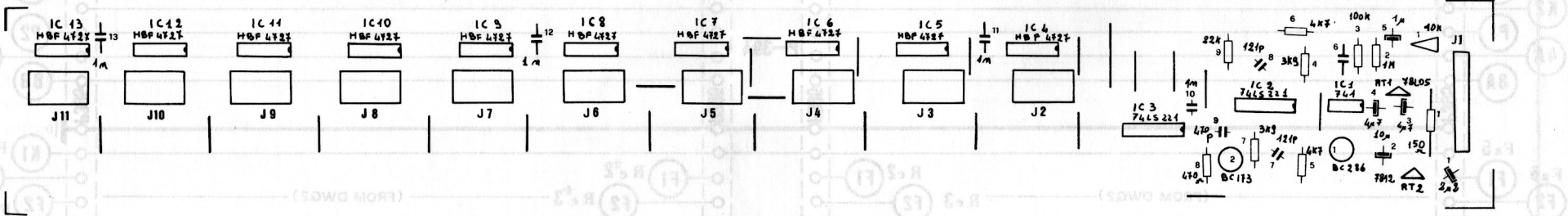

| | | | |
|-------------|-----------|-------------------|---------|
| CRUMAR | | MODEL: MULTIMAN 5 | |
| DRAWN BY | Bardani G | REVISION | |
| DESIGNED BY | Bianchi | DATE | 23/3/81 |

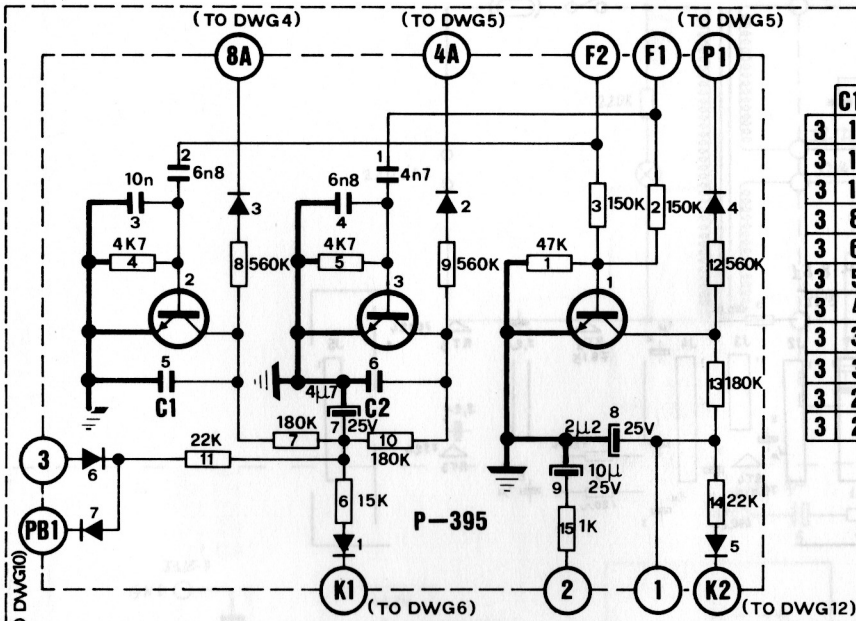

| | C1(nf) | C2(nf) | C1(nf) | C2(nf) | |
|---|--------|--------|--------|--------|---|
| 3 | 100 | 39 | 18 | 4.7 | 3 |
| 3 | 100 | 33 | 15 | 3.9 | 3 |
| 3 | 100 | 27 | 12 | 3.3 | 3 |
| 3 | 82 | 22 | 10 | 2.7 | 3 |
| 3 | 68 | 18 | 8.2 | 2.2 | 3 |
| 3 | 56 | 15 | 6.8 | 1.8 | 3 |
| 3 | 47 | 12 | 5.6 | 1.5 | 3 |
| 3 | 39 | 10 | 4.7 | 1.2 | 3 |
| 3 | 33 | 8.2 | 3.9 | 1 | 3 |
| 3 | 27 | 6.8 | 3.3 | 820P | 1 |
| 3 | 22 | 5.6 | | | |

P-394

(FROM DWG10)

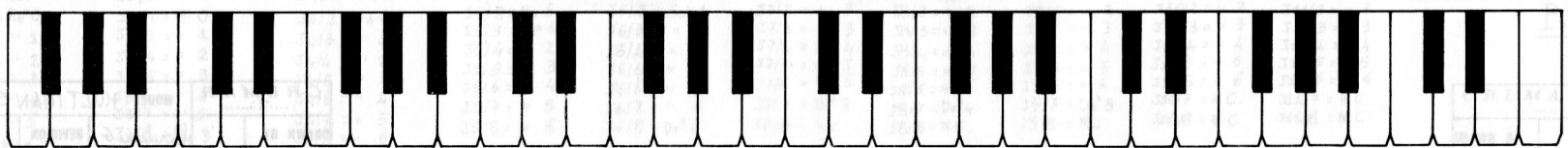
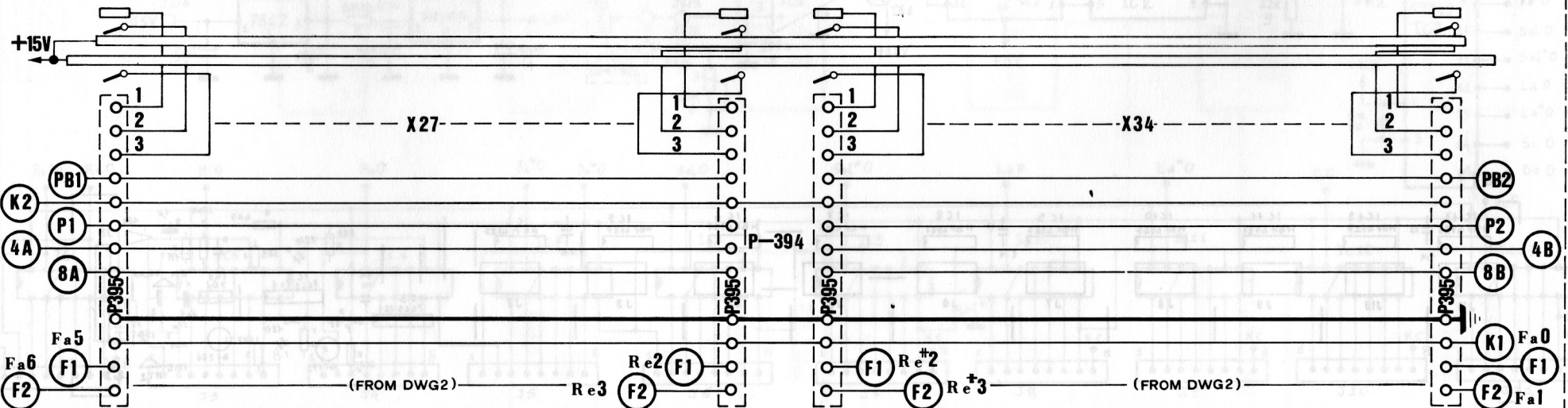
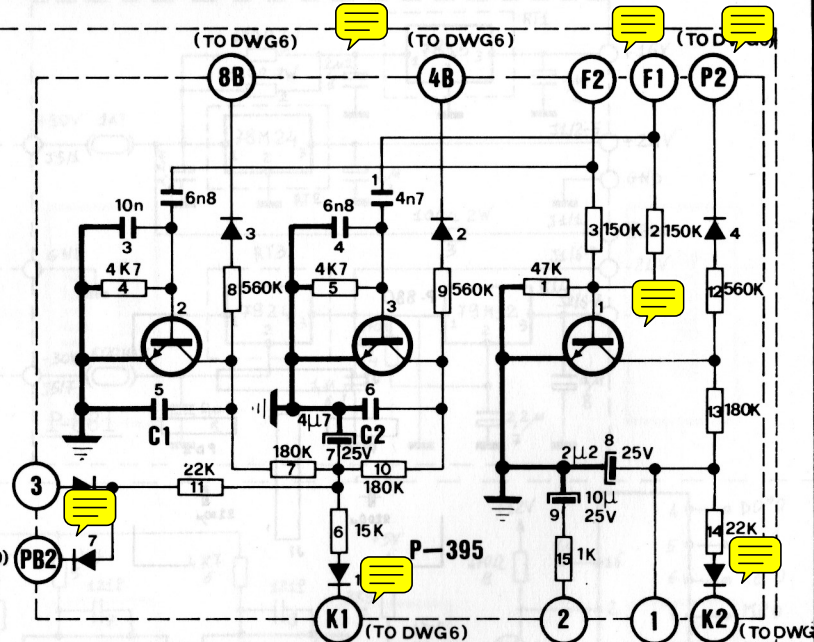

MODEL MULTIMAN-S
 DATE DRAWN BY DESIGNED BY
 Naspetti G. R. Brian

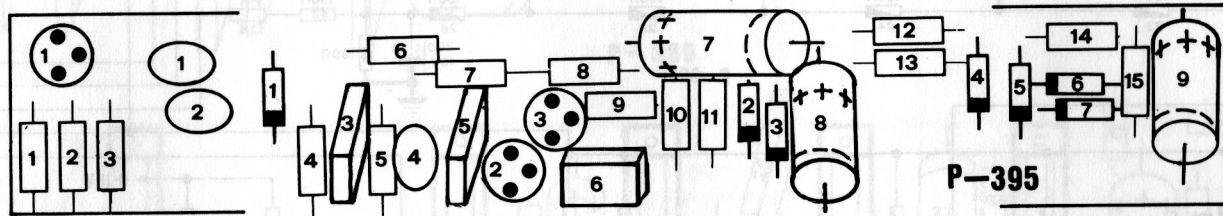

| | | | | | |
|-------|-------------------|----------------|----------|--|--|
| MODEL | MULTIMAN-S | | REVISION | | |
| DATE | DRAWN BY | DESIGNED BY | DATE | | |
| | <i>P. Roberts</i> | <i>R. Bran</i> | | | |

DWG 3A

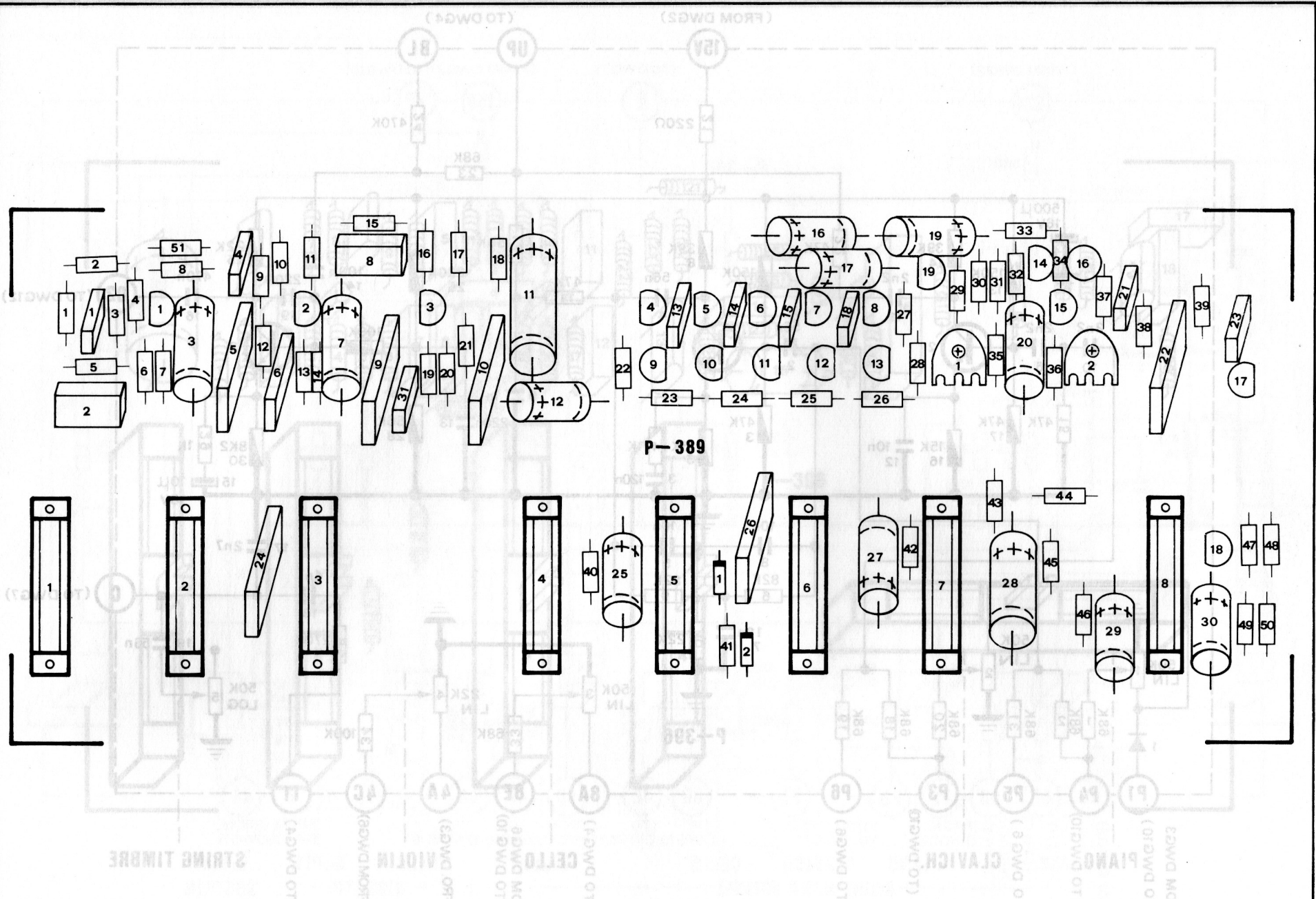

P-389

| | |
|-------------|------------|
| MODEL | MULTIMAN-2 |
| DATE | |
| DRAWN BY | R. Bran |
| DESIGNED BY | R. Bran |
| REVISION | |

| | | | | | |
|------------------|----------|-------------|----------|--|--|
| MODEL MULTIMAN-2 | | | REVISION | | |
| DATE | DRAWN BY | DESIGNED BY | DATE | | |
| | R. Bran | R. Bran | | | |

DWG 4A

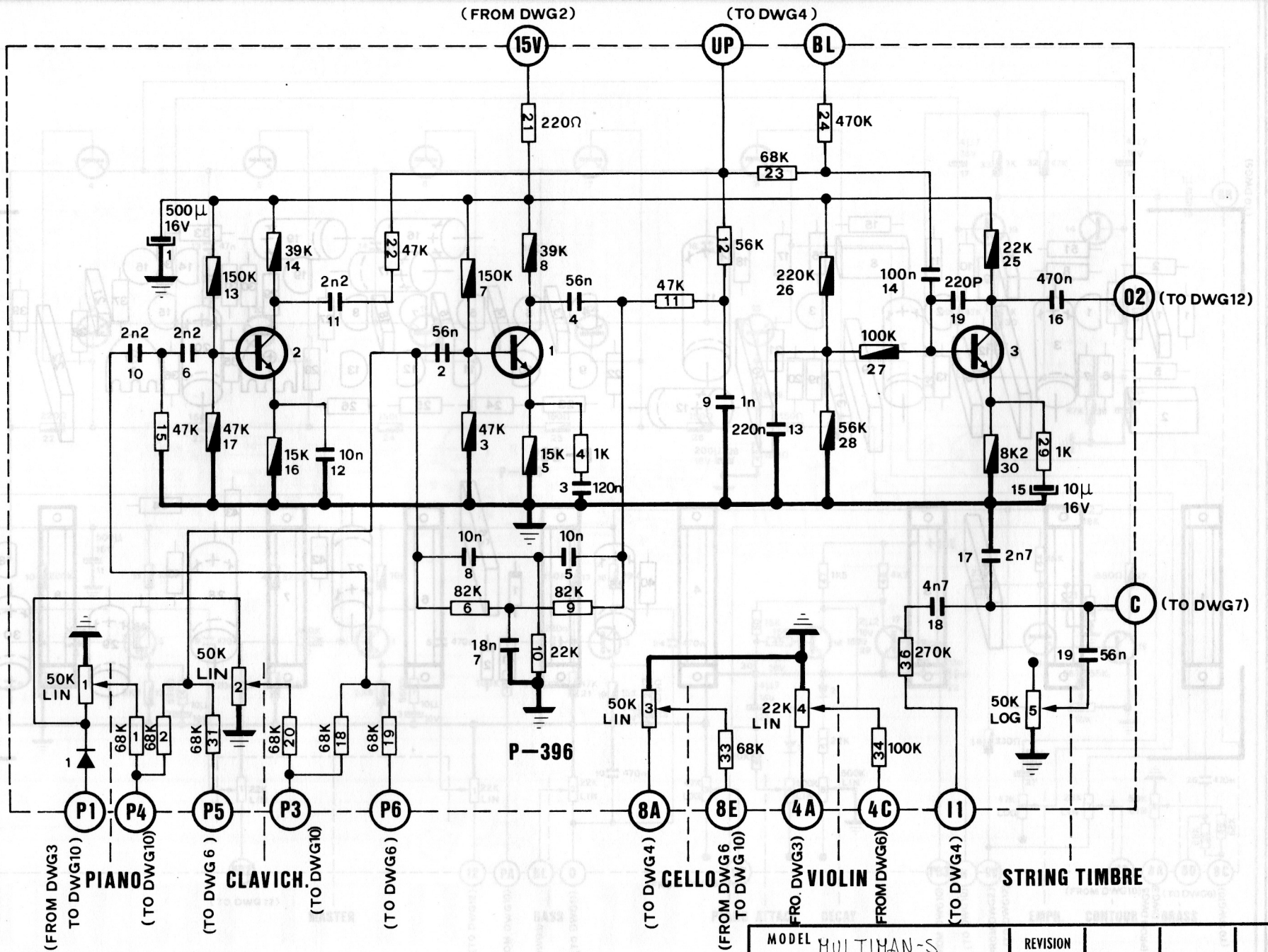

| | | | | |
|------------------|-----------------------------|----------------------------|------|--|
| MODEL MULTIMAN-S | | REVISION | | |
| DATE | DRAWN BY <i>G. Bazzetti</i> | DESIGNED BY <i>R. Bran</i> | DATE | |

DWG5

| | | | | |
|------------------|-----------------------------|--------------------------------|------|--|
| MODEL MULTIMAN-S | | REVISION | | |
| DATE | DRAWN BY <i>R. Brown</i> | DESIGNED BY <i>R. Brown</i> | DATE | |

DWG 5A

P-396

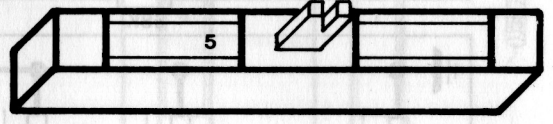
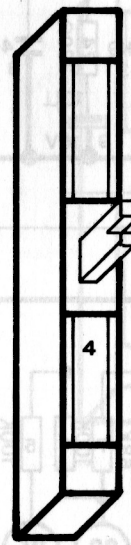
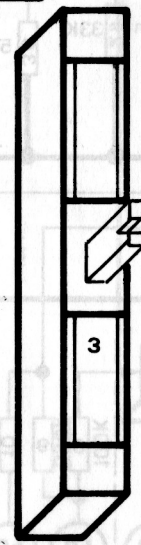
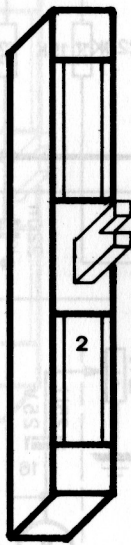
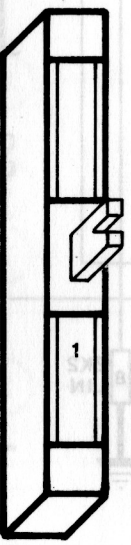
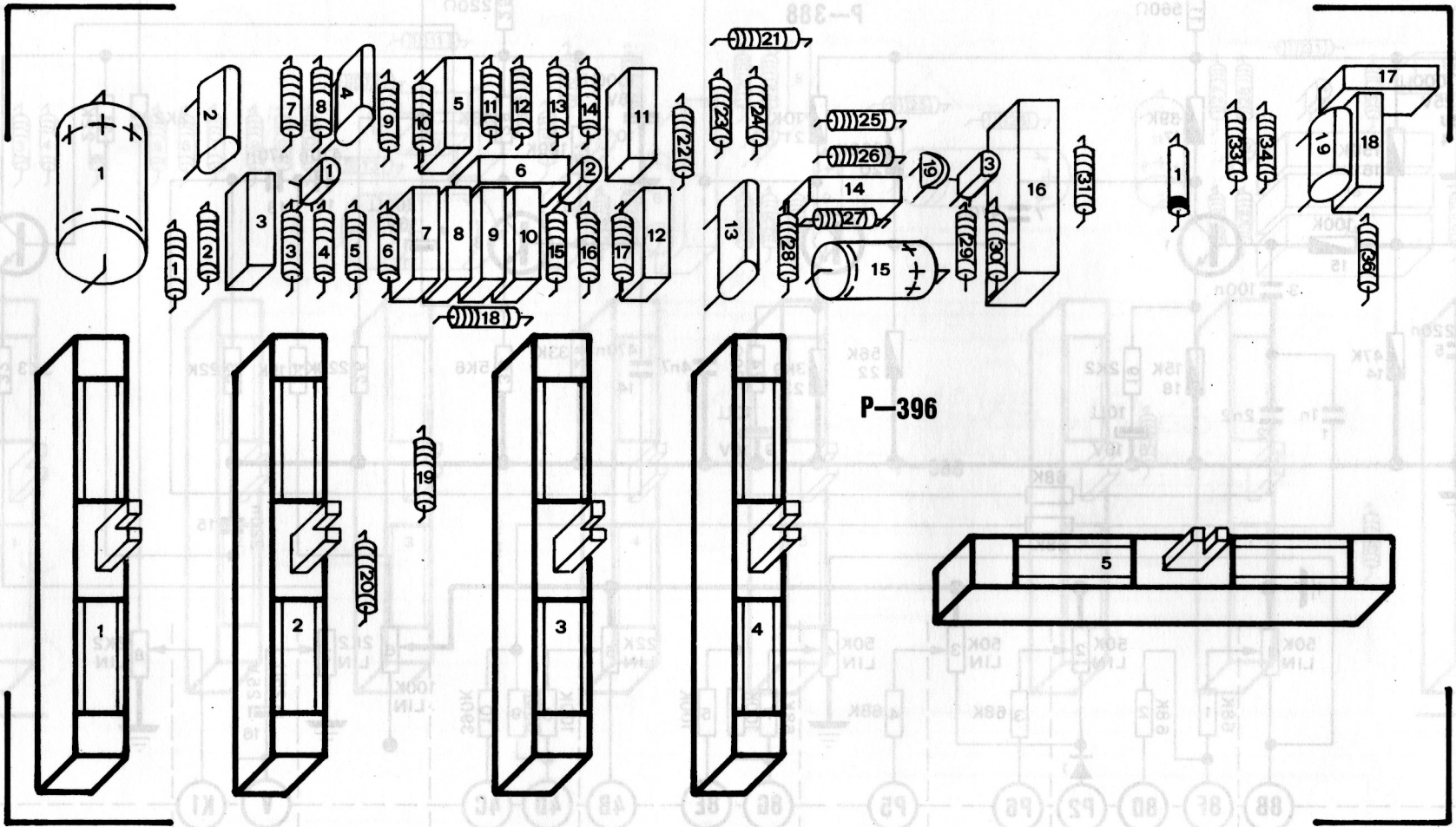

— VIBRATO —
SUSTAIN
DEPTH
LENGTH

VIBRIN

PIANO CLAVICH. CELLO

RIGHT HAND VOLUME

| | |
|-------------|-----------------|
| MODEL | MULTIMAN-S |
| REVISION | |
| DATE | |
| DRAWN BY | <i>R. Brown</i> |
| DESIGNED BY | <i>R. Brown</i> |

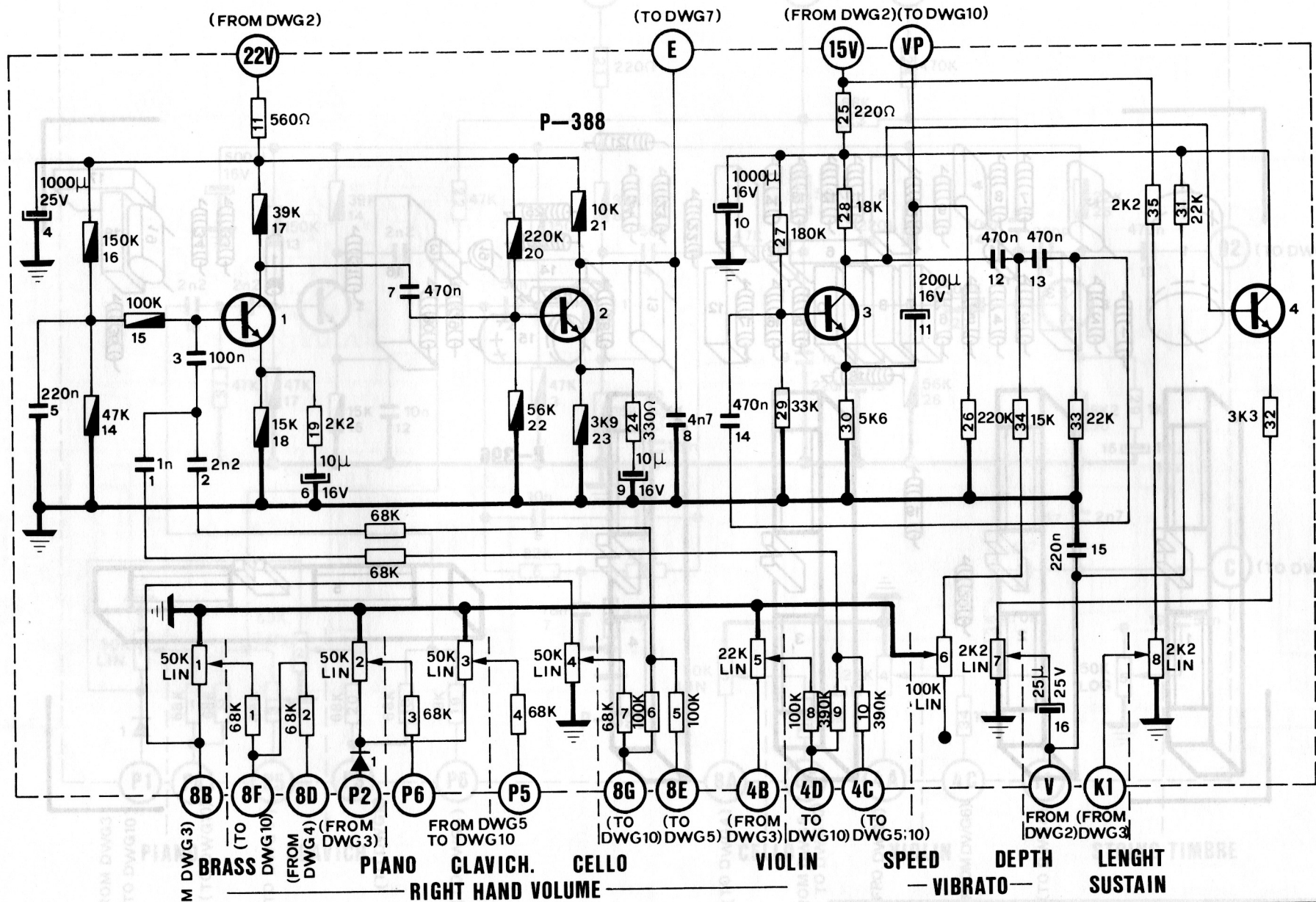

BRASS (FROM DWG3) PIANO (FROM DWG3) CLAVICH. (FROM DWG5 TO DWG10) CELLO (FROM DWG5 TO DWG10) VIOLIN (TO DWG10) (TO DWG5) (FROM DWG3) (TO DWG10) (TO DWG5:10) SPEED DEPTH LENGTH VIBRATO SUSTAIN

| | | | | | | | |
|-------|-----------|-------------|--|----------|--|--|--|
| MODEL | | MULTIMAN-S | | REVISION | | | |
| DATE | DRAWN BY | DESIGNED BY | | DATE | | | |
| | G. J. ... | R. Bran | | | | | |

DWG6

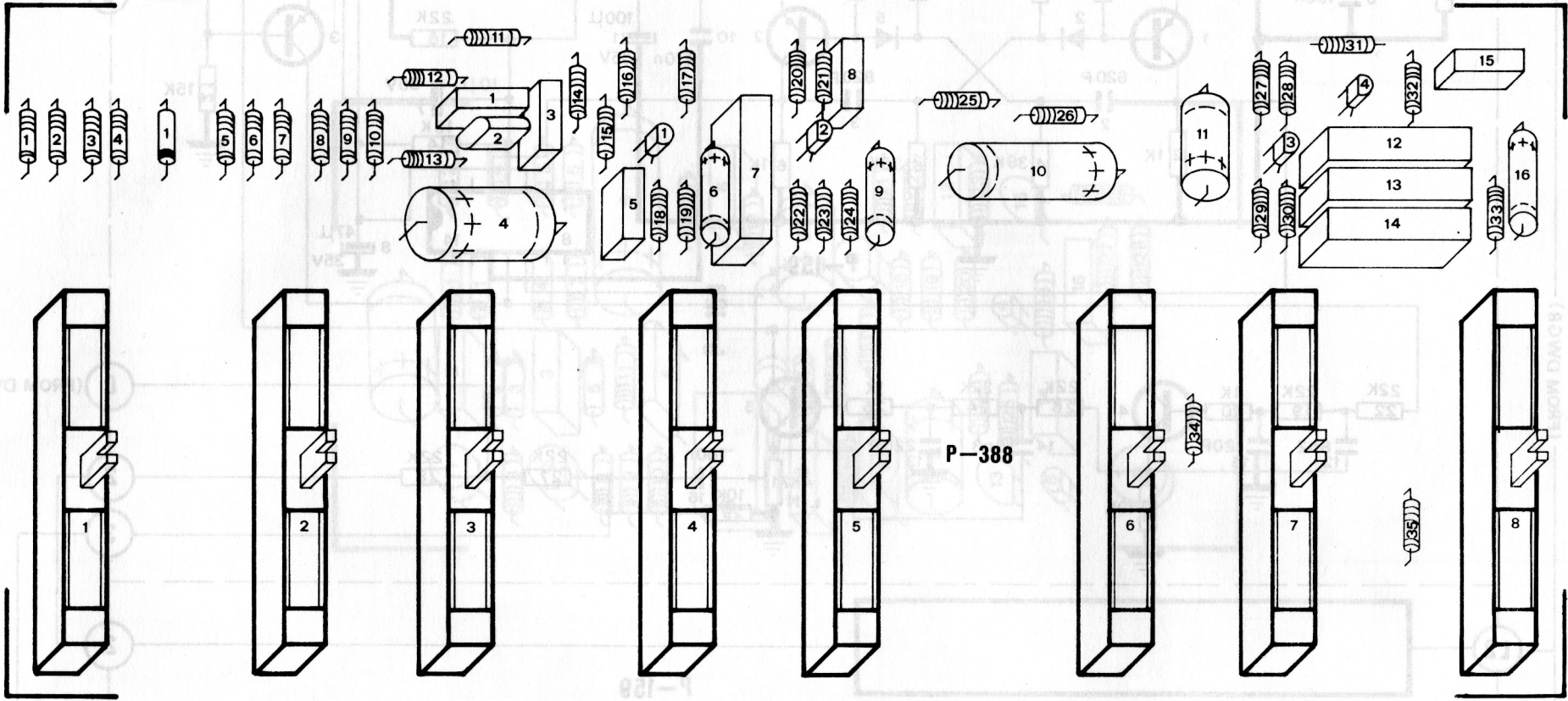

P-388

| | | | |
|----------|-------------|-------|-------------|
| REVISION | 2-ADDITION | MODEL | MULTIMAN-S |
| DATE | DESIGNED BY | DATE | DESIGNED BY |

| | | | | | |
|-------|--------------------|--------------------|------|--|--|
| MODEL | MULTIMAN-S | REVISION | | | |
| DATE | DRAWN BY | DESIGNED BY | DATE | | |
| | <i>[Signature]</i> | <i>[Signature]</i> | | | |

DWG 6A

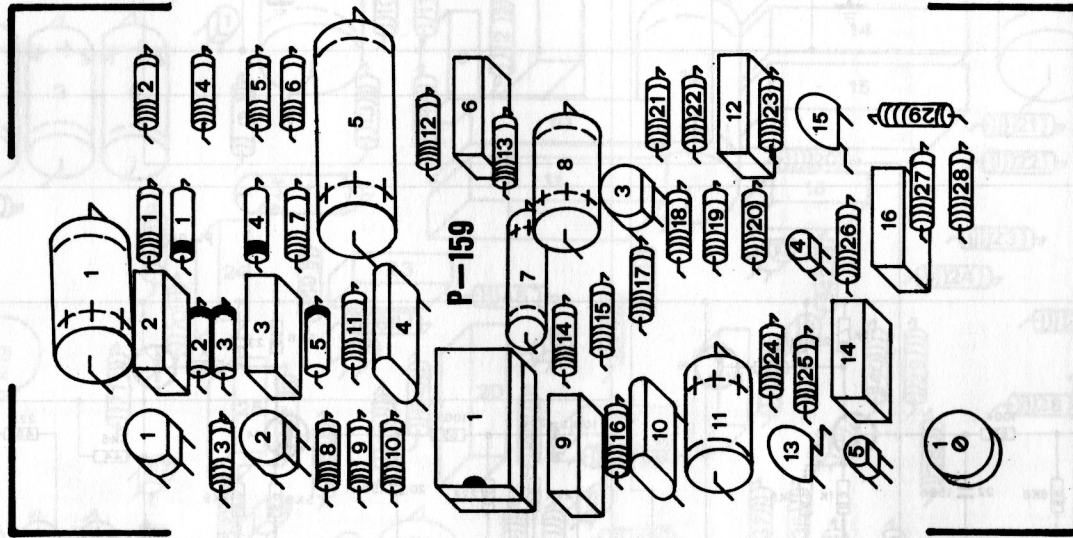

MODEL MULTIMAN-S
 DATE 11-28-54
 DRAWN BY R. Bran
 DESIGNED BY R. Bran

| MODEL MULTIMAN-S | | REVISION | | |
|------------------|----------|-------------|------|--|
| DATE | DRAWN BY | DESIGNED BY | DATE | |
| | R. Bran | R. Bran | | |

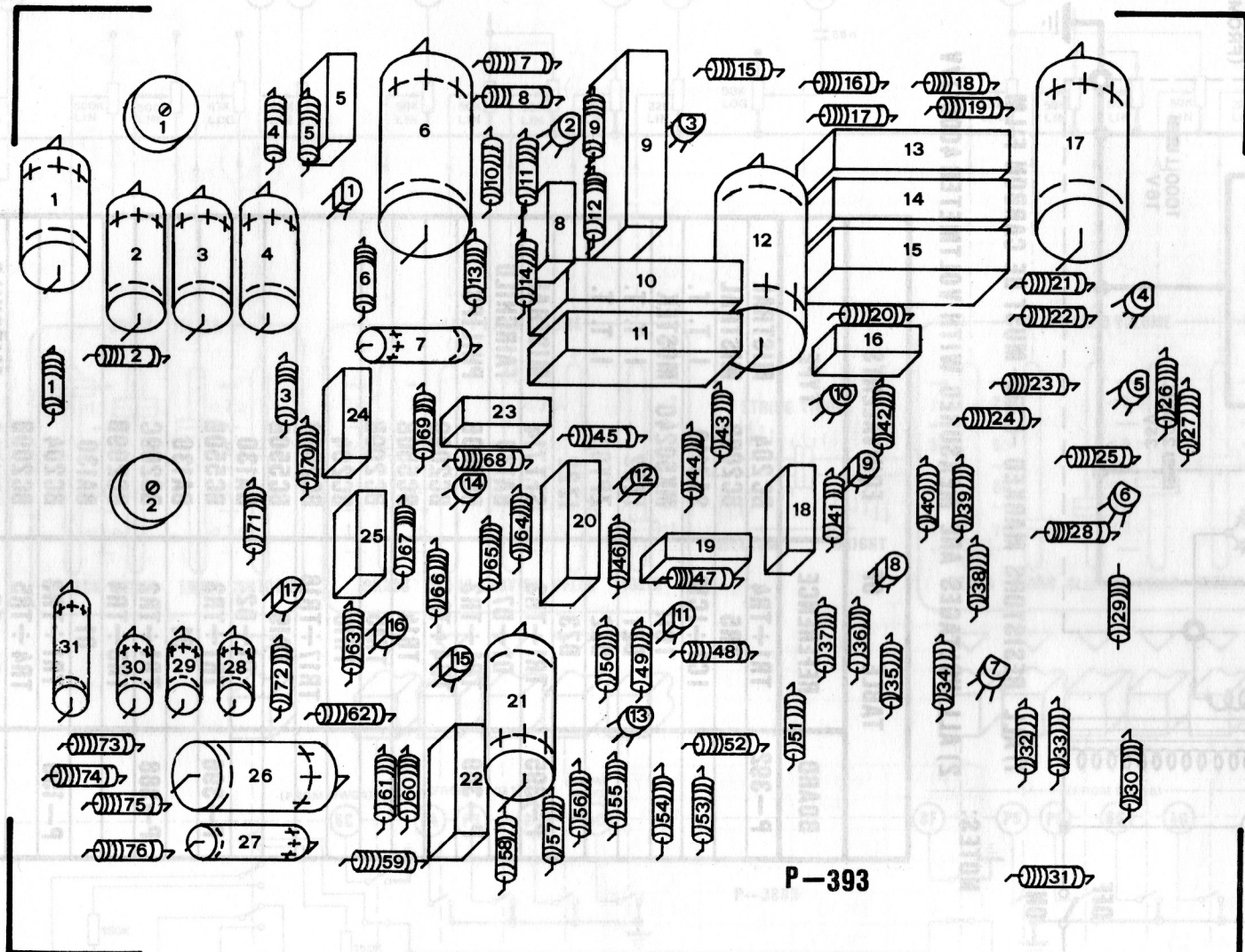

P-393

| MODEL MULTIMAN-S | | | REVISION | | |
|------------------|----------------|----------------|----------|--|--|
| DATE | DRAWN BY | DESIGNED BY | DATE | | |
| | <i>R. Bran</i> | <i>R. Bran</i> | | | |

DWG 8A

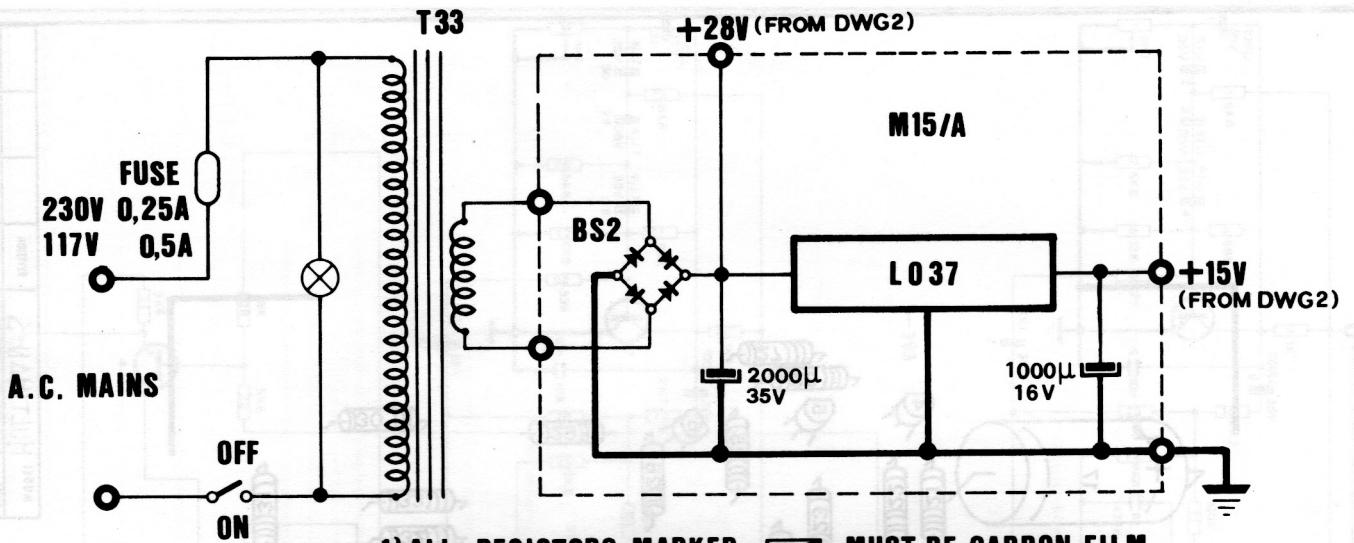

- NOTES:
- 1) ALL RESISTORS MARKED MUST BE CARBON FILM
 - 2) ALL VOLTAGES ARE MEASURED WITH VOLTMETER 4000Ω/V

| TABLE OF EQUIVALENTS | | | |
|----------------------|-----------|---------|-----------|
| BOARD | REFERENCE | TYPE | |
| P-392 | TR1÷TR4 | BC 204 | MISTRAL |
| | TR5 | BC209B | MISTRAL |
| | IC1÷IC10 | SAJ110 | I. T. T. |
| | IC11 | MK50240 | MOSTEK |
| | DZ1 | I222 | I. T. T. |
| | DZ2 | ZPY9,1 | I. T. T. |
| | DZ3 | I222 | |
| P-395 | TR1÷TR3 | SFT714 | MISTRAL |
| | D1÷D7 | BA130 | FAIRCHILD |
| P-389 | TR1÷TR3 | BC550B | PHILIPS |
| | TR4÷TR13 | BC209C | |
| | TR14 | BC550B | |
| | TR15 | BC209B | |
| | TR16 | BC204 | |
| | TR17÷TR18 | BC209B | |
| | TR19 | BC550B | |
| P-396 | D1÷D2 | BA130 | |
| | TR1÷TR3 | BC550B | |
| P-388 | D1 | BA130 | |
| | TR1÷TR2 | BC209C | |
| | TR3÷TR4 | BC209B | |
| P-159 | D1 | BA130 | |
| | TR1÷TR3 | BC204 | |
| | TR4÷TR5 | BC209B | |
| P-393 | D1÷D5 | FDH900 | FAIRCHILD |
| | TR1 | BC209C | |
| | TR2÷TR16 | BC209B | |
| | TR17 | BC209C | |

| | | | | |
|------------------|-----------------------------|----------------------------|------|--|
| MODEL MULTIHAN-S | | REVISION | | |
| DATE | DRAWN BY: <i>E. K. Seti</i> | DESIGNED BY: <i>Khoran</i> | DATE | |

Massima azione a pot. al massimo e Contour a -9 V

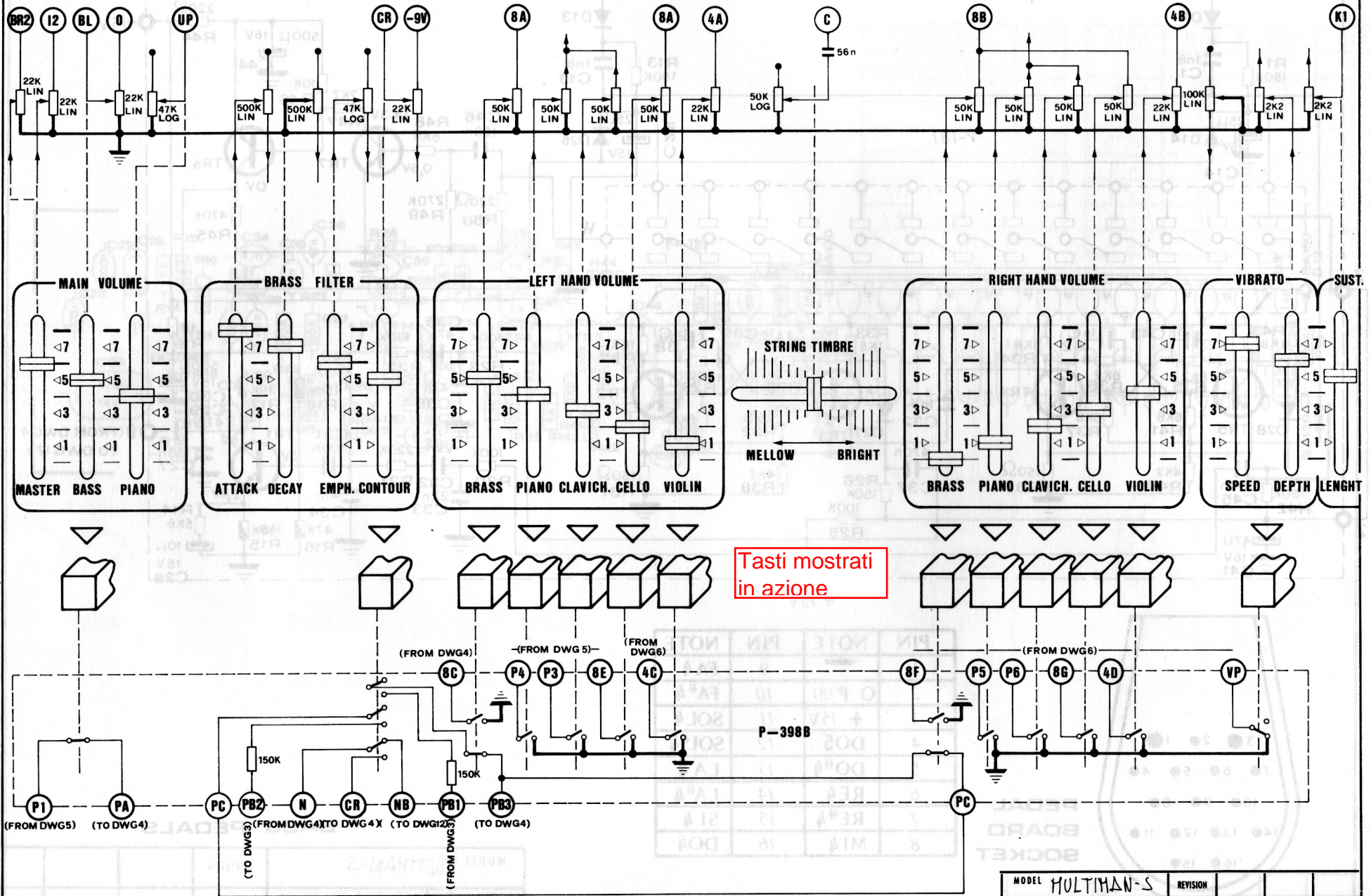

Tasti mostrati in azione

| | | | |
|-------|------------------------|------------------------|------|
| MODEL | MULTIMAN-5 | REVISION | |
| DATE | DRAWN BY G. Schmitt | DESIGNED BY R. Ryan | DATE |

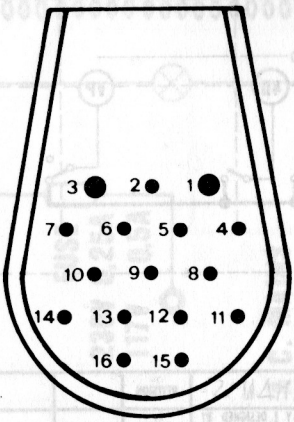
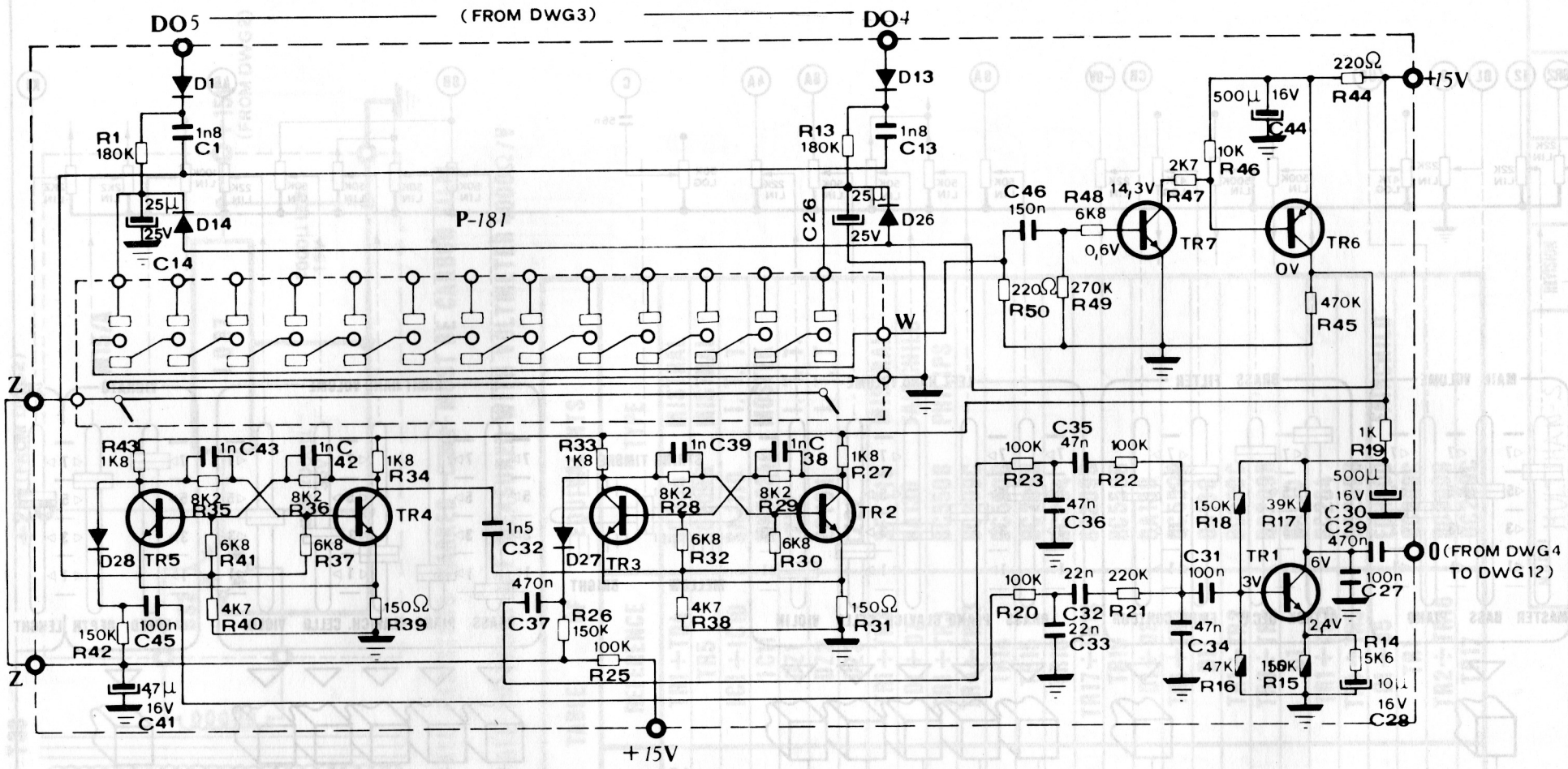

PEDAL BOARD SOCKET

| PIN | NOTE | PIN | NOTE |
|-----|----------|-----|-------|
| 1 | ⊖ | 9 | FA 4 |
| 2 | O · P181 | 10 | FA#4 |
| 3 | + 15V | 11 | SOL4 |
| 4 | DO5 | 12 | SOL#4 |
| 5 | DO#4 | 13 | LA 4 |
| 6 | RE4 | 14 | LA#4 |
| 7 | RE#4 | 15 | SI 4 |
| 8 | MI4 | 16 | DO4 |

BASS PEDALS

| | | | | | |
|-------|------------------------|-------------------------|------|--|--|
| MODEL | MULTIHAN-S | REVISION | | | |
| DATE | DRAWN BY Rosetti G. | DESIGNED BY R. Brani | DATE | | |

| PIN | NOTE |
|-----|----------------|
| 1 | +50V FROM DWG3 |
| 2 | K2 FROM DWG3 |
| 3 | |
| 4 | |
| 5 | |
| 6 | CA TO STEREO |
| 7 | CD TO STEREO |

| PIN | NOTE |
|-----|------|
| 9 | F4A |
| 10 | F4A |
| 11 | SOL4 |
| 12 | SOL4 |
| 13 | L4A |
| 14 | L4A |
| 15 | S1A |
| 16 | D4A |

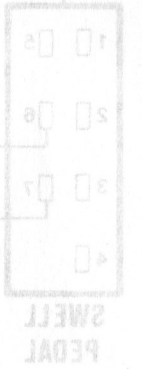
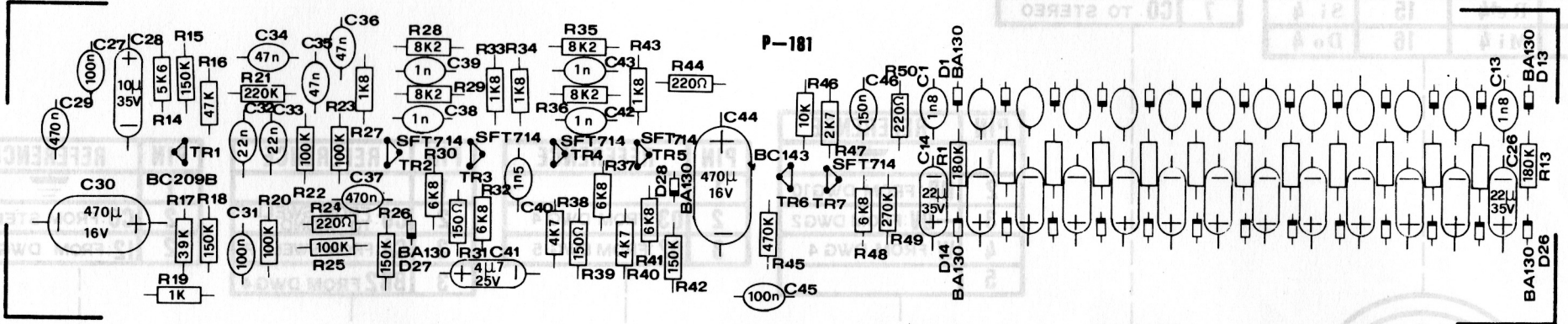

| REVISION | DATE |
|----------|------|
| 1 | |

| MODEL MULTIMAN-5 | | REVISION |
|------------------|-----------------|-------------------------|
| DATE | DRAWN BY fab | DESIGNED BY R. Brian |

DWG 11A

| PIN | NOTE | PIN | NOTE |
|-----|-------------------|-----|--------------------|
| 1 | — | 9 | Fa 4 |
| 2 | 0-P181 | 10 | Fa [#] 4 |
| 3 | +15V | 11 | Sol 4 |
| 4 | Do 5 | 12 | Sol [#] 4 |
| 5 | Do [#] 4 | 13 | La 4 |
| 6 | Re 4 | 14 | La [#] 4 |
| 7 | Re [#] 4 | 15 | Si 4 |
| 8 | Mi 4 | 16 | Do 4 |

| PIN | REFERENCE |
|-----|-----------------|
| 1 | +20V: FROM DWG2 |
| 2 | K2: FROM DWG3 |
| 3 | — |
| 4 | — |
| 5 | — |
| 6 | CA: TO STEREO |
| 7 | CO: TO STEREO |

| PIN | REFERENCE |
|-----|----------------|
| 1 | — |
| 2 | NB: FROM DWG10 |
| 3 | -9V: FROM DWG2 |
| 4 | W: FROM DWG 4 |
| 5 | — |

| PIN | REFERENCE |
|-----|----------------|
| 1 | — |
| 2 | 03: FROM DWG 4 |
| 3 | 02: FROM DWG 5 |

| PIN | REFERENCE |
|-----|------------------------------|
| 1 | — |
| 2 | CO: FROM SWELL P. TO MONO |
| 3 | CA: FROM SWELL P. |
| 3 | BR2: FROM DWG 4 |

| PIN | REFERENCE |
|-----|-----------------|
| 1 | — |
| 2 | CO: FROM STEREO |
| 2 | I2: FROM DWG 4 |

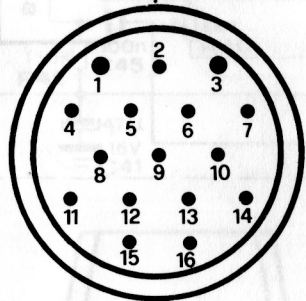

PEDAL BOARD

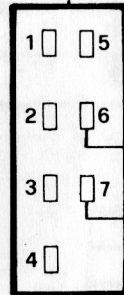

SWELL
PEDAL

CA

CO



PEDAL
FILTER



PIANOS

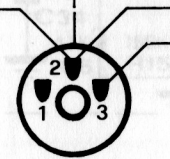

STEREO

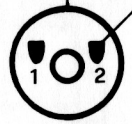

MONO

| | | | | |
|------------------|--------------------------|------------------------|------|--|
| MODEL MULTIMAN-S | | REVISION | | |
| DATE | DRAWN BY C. No. Pett. | DESIGNED BY R. Bran | DATE | |

CRUMAR S.p.A.
60022 CASTELFIDARDO - ITALY
c/p 98
Tel. (071) 79033 / 34