



Electro-Voice

PRO SOUND

Loudspeakers and Electronics



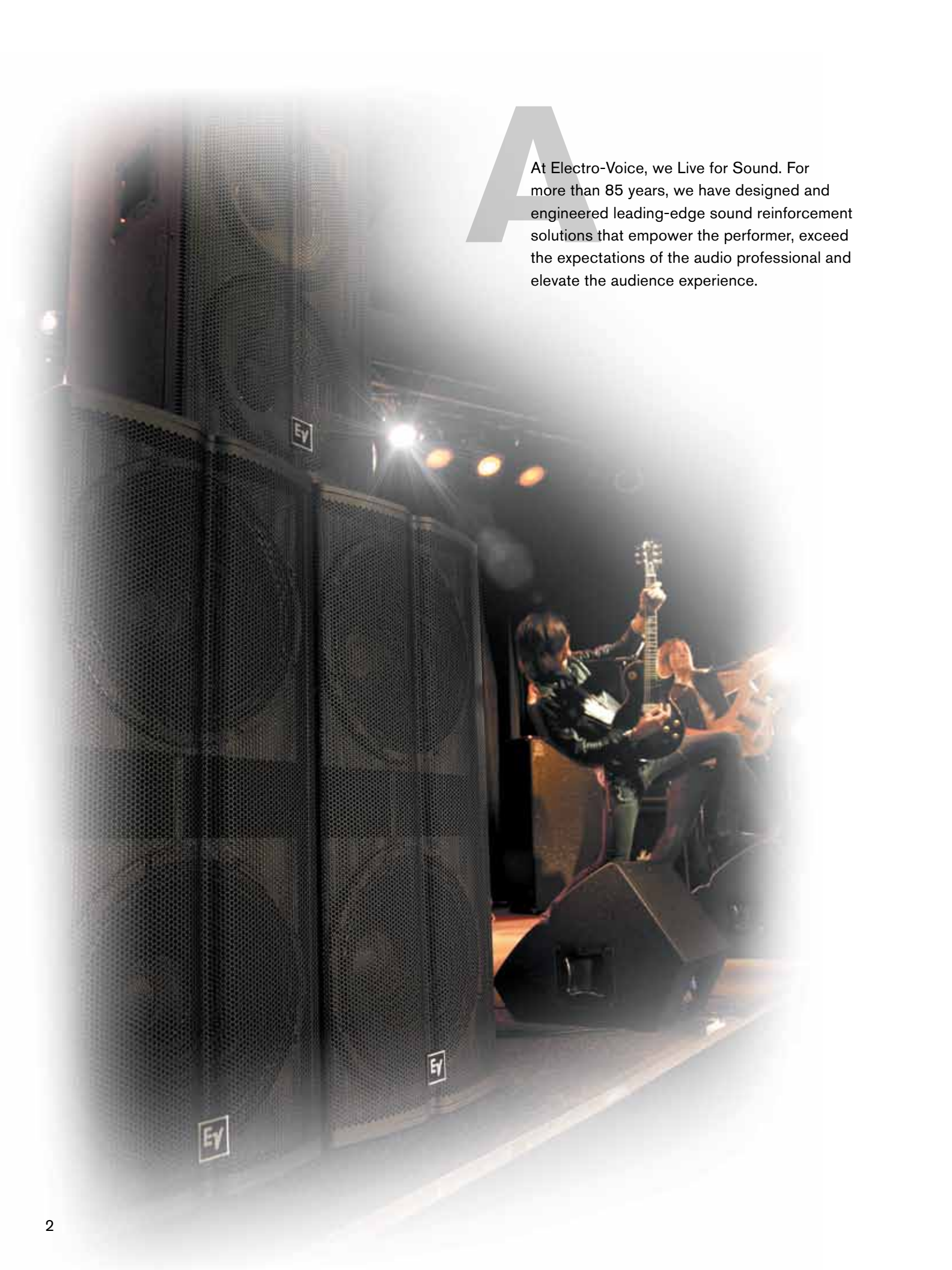

A At Electro-Voice, we Live for Sound. For more than 85 years, we have designed and engineered leading-edge sound reinforcement solutions that empower the performer, exceed the expectations of the audio professional and elevate the audience experience.

CONTENTS

| | |
|---|----|
| X-Line | 4 |
| XLC | 6 |
| XLCi | 7 |
| XLVC | 8 |
| Xi Series | 10 |
| EVF Front-Loaded Systems | 12 |
| EVF Front-Loaded Subwoofers | 16 |
| EVH Horn-Loaded Systems | 18 |
| EVA Expandable Vertical Array | 20 |
| EVA Subwoofers | 21 |
| EVU Ultracompact Systems | 22 |
| EVI Variable Intensity Loudspeakers Systems | 24 |
| EVID Surface-Mount Systems | 26 |
| EVID In-Wall Speaker Systems | 27 |
| EVID Ceiling Speaker Systems | 28 |
| Specialty Loudspeakers | 30 |
| Monitors | 31 |
| ZX/ZXA | 32 |
| EVM12L Guitar Speakers | 35 |
| SX | 36 |
| QRx | 38 |
| Tour X | 40 |
| Live X | 42 |
| ZLX | 44 |
| Rigging and Accessories | 46 |
| Tour Grade Amplifiers | 52 |
| Precision Series Remote Control Amplifiers | 54 |
| Q Series Amplifiers | 56 |
| CPS Contractor Precision Series Amplifiers | 58 |
| CP Compact Precision Amplifiers | 61 |
| PA Series Commercial Power Amplifiers | 62 |
| Netmax System Controller | 64 |
| Sound System Processors | 66 |





X-Line is a concert sound loudspeaker system that combines high-level sonic impact and vocal intelligibility with the uniform, predictable coverage that only a line array can deliver. The X-Line system provides wide horizontal dispersion from a single vertical line array with exceptionally coherent wave-front summation in the vertical plane. Extended low-frequency polar control produces more uniform power response, further enhancing overall intelligibility.

The two full-range boxes in the line are three-way systems that incorporate the Electro-Voice Hydra time-synchronized, high-frequency plane wave generator to provide excellent summing in the far field. They also employ Ring-Mode Decoupling (RMD) to provide level-independent fidelity, greater mid-bass clarity and high-frequency accuracy. All models in the line share the same footprint and are connected by proprietary rigging that facilitates rapid venue load-in and load-out.

Xvls

THREE-WAY LONG-THROW ELEMENT



- High-output, three-way line array system
- Rectangular cabinet design
- 90° horizontal coverage pattern ideal for long-throw applications
- EV Hydra time-synchronized vertical plane-wave generator provides excellent far-field summing
- Ring-Mode Decoupling (RMD) provides level-independent fidelity, greater mid-bass clarity and high-frequency accuracy
- Proprietary rigging allows for rapid venue load-in and load-out

Xvlt

THREE-WAY MEDIUM-THROW ELEMENT



- High-output, three-way line array system
- Five-degree trapezoidal cabinet design for lower "J" section of linear array
- 120° coverage typical for medium-throw assignment
- EV Hydra time-synchronized vertical plane-wave generator provides excellent far-field summing
- Ring-Mode Decoupling (RMD) provides level-independent fidelity, greater mid-bass clarity and high-frequency accuracy
- Proprietary rigging allows for rapid venue load-in and load-out

Xsub(F)

DUAL 18" SUBWOOFER ELEMENT



- High-output, line array subwoofer system
- Rectangular cabinet with footprint identical to other X-Line systems
- Can be flown or ground-stacked. Also available in non-flying version
- Proprietary rigging allows for rapid venue load-in and load-out

| | Xvls | Xvlt | Xsub(F) |
|--------------------------------------|---|---|---|
| Frequency Response (-3 dB) | 50–16,000 Hz | 50–16,000 Hz | 40–400 Hz |
| Frequency Range (-10 dB) | 30–17,000 Hz | 30–17,000 Hz | 35–500 Hz |
| Horizontal Coverage | 90° | 120° | — |
| Vertical Coverage* | 5° | 8° | — |
| LF Power Handling ¹ | 1200 W continuous, 4800 W peak | 1200 W continuous, 4800 W peak | 1200 W continuous, 4800 W peak ⁴ |
| MB Power Handling ² | 600 W continuous, 2400 W peak | 600 W continuous, 2400 W peak | — |
| HF Power Handling ³ | 225 W continuous, 900 W peak | 225 W continuous, 900 W peak | — |
| Sensitivity* LF/MB/HF | 98/108/114 dB | 97/107/114 dB | 104 dB (half space) |
| Max. SPL* (calc., peak), LF/MB/HF | 134/142/144 dB | 133/141/144 dB | 141 dB (half space) |
| Peak SPL @ 10m** | 135 dB | 135 dB | 132 dB (half space) |
| LF Transducer | Two 15" EVX-155PL | Two 15" EVX-155PL | Two 18" EVX-180B |
| MB Transducer | Two 8" ND08 | Two 8" ND08 | — |
| HF Transducer | Three 3" ND6-16 | Three 3" ND6-16 | — |
| Connectors | 2 Neutrik NL8 | 2 Neutrik NL8 | 2 Neutrik NL8 |
| Enclosure Material | Birch plywood, textured epoxy paint | Birch plywood, textured epoxy paint | Birch plywood, textured epoxy paint |
| Grille | Powder-coated steel | Powder-coated steel | Powder-coated steel |
| Environmental Specs | IEC 529 IP24, MIL STD 810 | IEC 529 IP24, MIL STD 810 | IEC 529 IP24, MIL STD 810 |
| Dimensions (H (front/rear) x W x D)* | 19.46"/19.46" x 49" x 29.15" (494.3/494.3 x 1244.6 x 740.4 mm) | 19.46"/16.92" x 49" x 29.15" (494.3/429.7 x 1244.6 x 740.4 mm) | 19.46"/19.46" x 49" x 29.15" (494.3/494.3 x 1244.6 x 740.4 mm) |
| Net Weight* | 257 lb (117 kg) | 253 lb (115 kg) | 202 lb (92 kg) |

*Single Box @ 1 Meter

**4 Box Array @ 10 Meters

¹ 50-200 Hz² 300-2000 Hz³ 1200-8000 Hz⁴ 50-100 Hz

XLC

Whether at a medium-sized festival, in a large concert hall or house of worship, or as a supplementary system used with X-Line, XLC compact line arrays have a proven record of performance and reliability. It's no wonder that XLC is

one of the most popular line array systems in the world. All modules incorporate Quik-Rig hardware for fast set-up and tear-down.

XLC127DVX XLC907DVX

120° HORIZONTAL THREE-WAY COMPACT LINE ARRAY ELEMENT
90° HORIZONTAL THREE-WAY COMPACT LINE ARRAY ELEMENT



- Accurate vertical control and coverage
- Compact, lightweight modules
- True three-way design
- Triamp operation; biamp operation with optional mid-high crossover (XLC127DVX only)
- Quik-Rig fast and simple integrated rigging
- Supported by LAPS II array design/prediction software

XLC215

HIGH-OUTPUT DUAL 15" SUBWOOFER LINE ARRAY ELEMENT



- 138 dB SPL
- Footprint identical to XLC127DVX
- Optional adapter grid for use with XLD281 and XLD291
- Two DVX3150A transducers
- Quik-Rig fast and simple integrated rigging

See page 46–47 for XLC Rigging and Accessories.

| | XLC127DVX | XLC907DVX | XLC215 |
|-----------------------------------|---|---|---|
| Frequency Response (-3 dB) | 65–16,000 Hz | 65–16,000 Hz | 40–400 Hz |
| Frequency Range (-10 dB) | 54–17,000 Hz | 54–17,000 Hz | 30–400 Hz |
| Horizontal Coverage | 120° | 90° | — |
| LF Power Handling ¹ | 500 W continuous, 2000 W peak | 500 W continuous, 2000 W peak | 1000 W continuous, 4000 W peak ⁴ |
| MB Power Handling ² | 300 W continuous, 1200 W peak | 300 W continuous, 1200 W peak | — |
| HF Power Handling ³ | 150 W continuous, 600 W peak | 150 W continuous, 600 W peak | — |
| Sensitivity* LF/MB/HF | 95/101/111 dB | 95/101/112 dB | 102 dB |
| Max. SPL* (calc., peak), LF/MB/HF | 128/132/139 dB | 128/132/140 dB | 138 dB |
| Peak SPL @ 10m** | 130 dB | 130 dB | 124 dB |
| LF Transducer | 12" DVX3121A | 12" DVX3121A | Two 15" DVX3150A |
| MB Transducer | Two 6.5" DVN2065 | Two 6.5" DVN2065 | — |
| HF Transducer | Two 3" ND6-16 | Two 3" ND6-16 | — |
| Connectors | 2 Neutrik NL8 | 2 Neutrik NL8 | 2 Neutrik NL8 |
| Enclosure Material | EVCoat-coated birch plywood | EVCoat-coated birch plywood | EVCoat-coated birch plywood |
| Grille | Powder-coated steel | Powder-coated steel | Powder-coated steel |
| Environmental Specs | IEC 529 IP24, MIL STD 810 | IEC 529 IP24, MIL STD 810 | IEC 529 IP24, MIL STD 810 |
| Dimensions (H x W x D)* | 14.25" x 39" x 22.5" (362 x 991 x 572 mm) | 14.25" x 39" x 22.5" (362 x 991 x 572 mm) | 21.5" x 39" x 22.5" (546 x 991 x 572 mm) |
| Net Weight* | 111 lb (50.4 kg) | 111 lb (50.4 kg) | 129 lb (58.5 kg) |

*Single Box @ 1 Meter
**4 Box Array @ 10 Meters

¹ 100-500 Hz

² 500-2000 Hz

³ 1600-8000 Hz

⁴ 60-100 Hz



XLCi

XLCi is a version of the XLC line that has been adapted for permanent installations. XLCi features visually appealing rigging that won't distract from architectural aesthetics. The performance of the three modules in the line is identical

to that of the corresponding model in the XLC line. XLCi loudspeakers are supported by LAPS II array design/prediction software.

XLCi127DVX XLCi907DVX

120° HORIZONTAL THREE-WAY COMPACT LINE ARRAY ELEMENT
90° HORIZONTAL THREE-WAY COMPACT LINE ARRAY ELEMENT



- Accurate vertical control and coverage
- Compact, lightweight modules
- True three-way design
- Triamp operation; biamp operation with optional mid-high crossover (XLCi127DVX only)
- Fixed installation rigging
- Supported by LAPS II array design/prediction software

XLCi215

HIGH-OUTPUT DUAL 15" SUBWOOFER ELEMENT



- Footprint identical to other XLCi models
- Two DVX3150A transducers
- Compact and lightweight
- Fixed installation rigging

See page 47 for XLCi Rigging and Accessories.

| | XLCi127DVX | XLCi907DVX | XLCi215 |
|-----------------------------------|---|---|---|
| Frequency Response (-3 dB) | 65–16,000 Hz | 65–16,000 Hz | 40–400 Hz |
| Frequency Range (-10 dB) | 54–17,000 Hz | 54–17,000 Hz | 30–400 Hz |
| Horizontal Coverage | 120° | 90° | 300° |
| LF Power Handling ¹ | 500 W continuous, 2000 W peak | 500 W continuous, 2000 W peak | 1000 W continuous, 4000 W peak ⁴ |
| MB Power Handling ² | 300 W continuous, 1200 W peak | 300 W continuous, 1200 W peak | — |
| HF Power Handling ³ | 150 W continuous, 600 W peak | 150 W continuous, 600 W peak | — |
| Sensitivity* LF/MB/HF | 95/101/111 dB | 95/101/112 dB | 102 dB |
| Max. SPL* (calc., peak), LF/MB/HF | 128/132/139 dB | 128/132/140 dB | 138 dB |
| Peak SPL @ 10m** | 130 dB | 130 dB | 124 dB |
| LF Transducer | 12" DVX3121A | 12" DVX3121A | Two 15" DVX3150A |
| MB Transducer | Two 6.5" DVN2065 | Two 6.5" DVN2065 | — |
| HF Transducer | Two 3" ND6-16 | Two 3" ND6-16 | — |
| Connectors | 2 Neutrik NL8 | 2 Neutrik NL8 | 2 Neutrik NL8 |
| Enclosure Material | EVCoat-coated birch plywood | EVCoat-coated birch plywood | EVCoat-coated birch plywood |
| Grille | Powder-coated steel | Powder-coated steel | Powder-coated steel |
| Environmental Specs | IEC 529 IP24, MIL STD 810 | IEC 529 IP24, MIL STD 810 | IEC 529 IP24, MIL STD 810 |
| Dimensions (H x W x D)* | 14.25" x 36.5" x 22.5" (362 x 927 x 572 mm) | 14.25" x 36.5" x 22.5" (362 x 927 x 572 mm) | 21.5" x 36.5" x 22.5" (546 x 927 x 572 mm) |
| Net Weight* | 105 lb (48.1 kg) | 105 lb (48.1 kg) | 124 lb (56.3 kg) |

*Single Box @ 1 Meter
**4 Box Array @ 10 Meters
¹ 100-500 Hz
² 500-2000 Hz
³ 1600-8000 Hz
⁴ 60-100 Hz



XLVC

When a line array with limited size and weight is required, XLVC is the choice of professionals around the world. XLVC Very Compact Line Arrays combine reliability, intelligibility and acoustic performance in a package that is easy to

configure and suspend. All cabinets feature simple, quick, integrated rigging. System design is easy using Electro-Voice's free LAPS II array design/prediction software.

XLD281

120° HORIZONTAL THREE-WAY DUAL 8" LINE ARRAY ELEMENT



- Full-bandwidth, three-way element (60 Hz – 20 kHz)
- CCT (Coverage Control Technology)
- Versatile subwoofer integration
- Biamp or triamp operation
- Neodymium transducers
- Simple, quick, integrated rigging
- Supported by LAPS II array design/prediction software

XLD291

90° HORIZONTAL THREE-WAY DUAL 8" LINE ARRAY ELEMENT



- Full-bandwidth, three-way element
- CCT maintains 90° horizontal coverage to 250 Hz
- Versatile subwoofer integration
- Biamp or triamp operation
- Neodymium transducers
- Simple, quick, integrated rigging
- Supported by LAPS II array design/prediction software

XLE181

120° HORIZONTAL TWO-WAY SINGLE 8" LINE ARRAY ELEMENT

XLE191

90° HORIZONTAL TWO-WAY SINGLE 8" LINE ARRAY ELEMENT



- Full-bandwidth, two-way element
- Most compact, very lightweight
- Biamp or full-range operation
- Neodymium transducers
- Simple, quick, integrated rigging
- Supported by LAPS II array design/prediction software

XCS312

TRIPLE 12" CARDIOID BASS ELEMENT



- Versatile integration in main arrays
- Self-contained rigging hardware
- Supported by LAPS II array design/prediction software

See page 46–47 for XLVC Rigging and Accessories.

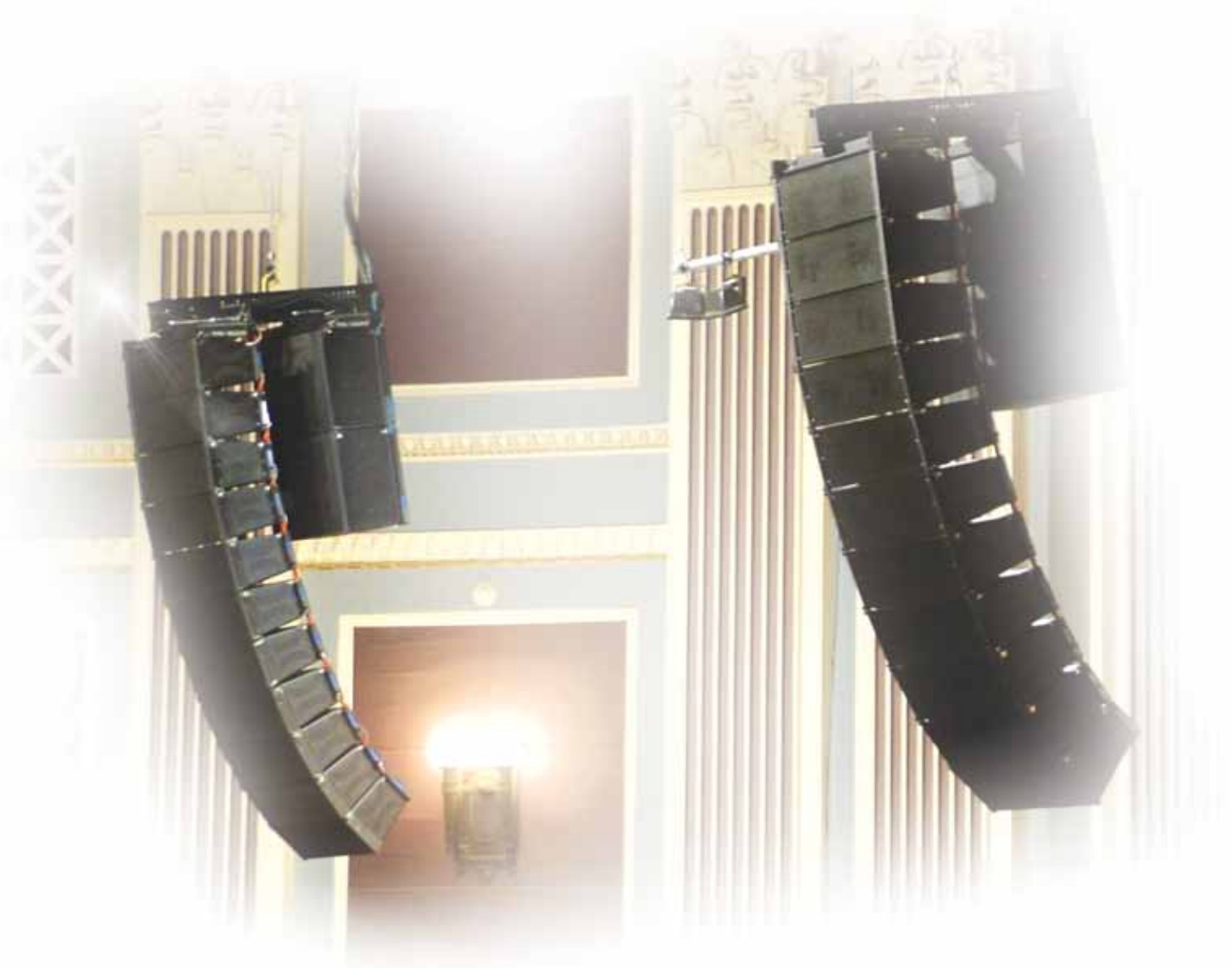

LOUDSPEAKERS

CONCERT

INSTALL

PORTABLE PA

| | XLD281 | XLD291 | XLE181 | XLE191 | XCS312 |
|-----------------------------------|--|--|---|---|---|
| Frequency Response (-3 dB) | 65–16,000 Hz | 65–16,200 Hz | 65–16,000 Hz | 65–16,200 Hz | 45–100 Hz |
| Frequency Range (-10 dB) | 56–16,500 Hz | 56–16,700 Hz | 56–16,500 Hz | 56–16,700 Hz | 40–100 Hz |
| Horizontal Coverage | 120° | 90° | 120° | 90° | 200° |
| LF1 Power Handling ¹ | 200 W continuous, 800 W peak | 200 W continuous, 800 W peak | 200 W continuous, 800 W peak | 200 W continuous, 800 W peak | 1000 W continuous, 4000 W peak ⁴ |
| LF2 Power Handling ² | 200 W continuous, 800 W peak | 200 W continuous, 800 W peak | — | — | 500 W continuous, 2000 W peak ⁴ |
| HF Power Handling ³ | 80 W continuous, 320 W peak | 80 W continuous, 320 W peak | 80 W continuous, 320 W peak | 80 W continuous, 320 W peak | — |
| Sensitivity* LF-MB/HF | 99/112 dB | 99/113 dB | 99/112 dB | 99/113 dB | 100 dB (half space) |
| Max. SPL* (calc., peak), LF-MB/HF | 128/137 dB | 128/138 dB | 128/137 dB | 128/138 dB | 136 dB (half space) |
| Peak SPL @ 10m** | 129 dB | 130 dB | 129 dB | 130 dB | 121 dB |
| LF Transducer | 8" DVN2080 | 8" DVN2080 | 8" DVN2080 | 8" DVN2080 | Three 12" DVX3120A |
| LF-MB Transducer | 8" DVN2080 | 8" DVN2080 | — | — | — |
| HF Transducer | Two 2" ND2S | Two 2" ND2S | Two 2" ND2S | Two 2" ND2S | — |
| Connectors | 2 Neutrik NL8 | 2 Neutrik NL8 | 2 Neutrik NL8 | 2 Neutrik NL8 | 2 Neutrik NL8 |
| Enclosure Material | EVCoat-coated birch plywood | EVCoat-coated birch plywood | EVCoat-coated birch plywood | EVCoat-coated birch plywood | EVCoat-coated birch plywood |
| Grille | Powder-coated steel | Powder-coated steel | Powder-coated steel | Powder-coated steel | Powder-coated steel |
| Environmental Specs | IEC 529 IP24, MIL STD 810 | IEC 529 IP24, MIL STD 810 | IEC 529 IP24, MIL STD 810 | IEC 529 IP24, MIL STD 810 | IEC 529 IP24, MIL STD 810 |
| Dimensions (H x W x D) | 9.9" x 28.58" x 14.52" (251 x 726 x 369 mm) | 9.9" x 28.58" x 14.52" (251 x 726 x 369 mm) | 9.9" x 20.3" x 14.52" (251 x 516 x 369 mm) | 9.9" x 20.3" x 14.52" (251 x 516 x 369 mm) | 20" x 28.58" x 26.65" (508 x 726 x 677 mm) |
| Net Weight | 48 lb (21.8 kg) | 48 lb (21.8 kg) | 17.24 kg (38 lb) | 38 lb (17.24 kg) | 148 lb (67.13 kg) |

*Single Box @ 1 Meter

**4 Box Array @ 10 Meters

¹ 750-1750 Hz² 100-750 Hz³ 1500-6500 Hz⁴ 60-100 Hz



Xi Series



The Electro-Voice Xi Series offers a potent combination of high output and ultra-linear performance in two-way systems. Xi Series loudspeakers incorporate the acoustic advantages of Ring-Mode Decoupling (RMD) and feature HP Constant Directivity waveguides to secure excellent directivity control and even coverage. To achieve sound performance without compromise, the Xi Series is designed for active operation, with the exception of the

Xi-1082, which contains a passive crossover network. Xi loudspeaker cabinets are made of 18 mm, 13-ply birch plywood finished in a black EVCoat and protected by a full-face, steel front grille that is backed with foam. All systems except the Xi-1082 have integrated handles and two L-tracks on the top and bottom. A detailed flying manual is available.

Xi-1082

8" TWO-WAY FULL-RANGE LOUDSPEAKER



- Ultra-compact, low profile
- Wide-range reproduction, maximized intelligibility
- Optimal under-balcony enclosure angles
- Suited for front-of-stage and near-field use
- Trapezoidal enclosure, vented for extended LF
- 1.25" DH3/2010A titanium-diaphragm HF driver
- Two 3/8" mounting bracket inserts
- Compatible with OmniMount® Series 100
- EVCoat finish
- Available in black or white
- Mounting bracket available separately

Xi-1122A/85F

15" TWO-WAY FULL-RANGE LOUDSPEAKER



- Ultra-compact, high output
- Professional touring or installation
- Maximum intelligibility for voice
- 3" neodymium HF driver
- Trapezoidal (15°/side) 13-ply birch enclosure
- Built-in L-Track rigging
- 35 mm stand mount
- Integrated handles
- Available in black or white

Xi-1152A/64F Xi-1152A/94F

15" TWO-WAY FULL-RANGE LOUDSPEAKERS



- High-SPL in limited-space applications
- Maximum intelligibility for voice
- EVX155 woofer with 4" voice coil and Ring-Mode Decoupling (RMD)
- 3" ND6-16 neodymium HF driver
- Rotatable 60° x 40° (64F) or 90° x 40° (94F) coverage
- Solid bass down to 50 Hz (-3 dB)
- Trapezoidal (15°/side) 13-ply birch enclosure
- Built-in L-Track rigging
- 35 mm stand mount
- Integrated handles
- Available in black or white

See page 47 for XI-1082 Rigging and Accessories.



LOUDSPEAKERS

CONCERT

INSTALL

PORTABLE PA

| | Xi-1082 | Xi-1122A/85F | Xi-1152A/64F | Xi-1152A/94F |
|------------------------------------|---|--|--|--|
| Frequency Response (-3 dB) | 50–20,000 Hz (-10 dB) | 58–17,000 Hz | 50–16,000 Hz | 50–16,000 Hz |
| Recommended High-Pass Frequency | 60–80 Hz (12 dB/octave) | Dx46 preset | Dx46 preset | Dx46 preset |
| Axial Sensitivity (SPL, 1 W @ 1 m) | 90 dB (LF/HF) | 99/110 dB (LF/HF) | 98/113 dB (LF/HF) | 98/112 dB (LF/HF) |
| Max. SPL @ 1 m (calc.), full space | 118 dB (LF/HF) | 130/135 dB (LF/HF) | 132/138 dB (LF/HF) | 132/137 dB (LF/HF) |
| Long-Term Power Handling | 175 W (LF/HF) | 300/75 W (LF/HF) | 600/75 W (LF/HF) | 600/75 W (LF/HF) |
| Short-Term Power Handling (peak) | 700 W (LF/HF) | 1200/300 W (LF/HF) | 2400/300 W (LF/HF) | 2400/300 W (LF/HF) |
| Coverage (nominal -6 dB) H° x V° | 90° x 40° (Const. Dir. waveguide) | 80° x 55° (Const. Dir. waveguide) | 60° x 40° (Const. Dir. waveguide) | 90° x 40° (Const. Dir. waveguide) |
| Directivity Index | 11.2 dB (+1.8/-2.7 dB) 2,000–20,000 Hz | 10.9 dB (+1.2/-2.9 dB) 1,200–16,000 Hz | 13.4 dB (+1.3/-2.3 dB) 1,200–16,000 Hz | 12.3 dB (+0.7/-1.5 dB) 1,200–16,000 Hz |
| LF woofer (transducer) | 8" | 12" DL-type | 15" EVX155 | 15" EVX155 |
| MB woofer (transducer) | — | — | — | — |
| HF driver (transducer) | 1.25" DH3/2010A | 3" ND6-16 | 3" ND6-16 | 3" ND6-16 |
| Crossover Frequencies | 3,500 Hz (passive) | Dx46 preset | Dx46 preset | Dx46 preset |
| Nominal Impedance | 8 Ω (LF/HF) | 8 Ω/16 Ω (LF/HF) | 8 Ω/16 Ω (LF/HF) | 8 Ω/16 Ω (LF/HF) |
| Minimum Impedance | 5.8 Ω (LF/HF) | 8.5 Ω/13.4 Ω (LF/HF) | 6.3 Ω/14.0 Ω (LF/HF) | 6.3 Ω/12.2 Ω (LF/HF) |
| Input Connections | Barrier strip | 2 four-pin Speakon | 2 four-pin Speakon | 2 four-pin Speakon |
| Dimensions (H x W at front x D) | 9.25" x 11.21" x 11.22" (235 x 488 x 285 mm) | 22.99" x 14.76" x 14.01" (584 x 375 x 356 mm) | 29.88" x 17.72" x 16.26" (759 x 450 x 413 mm) | 29.88" x 17.72" x 16.26" (759 x 450 x 413 mm) |
| Net Weight | 29.3 lb (13.3 kg) | 69 lb (31.3 kg) | 89.9 lb (40.8 kg) | 89.9 lb (40.8 kg) |



LOUDSPEAKERS
CONCERT
INSTALL
PORTABLE PA

EVF is the most comprehensive standard line of front-loaded loudspeaker systems ever offered for installed sound. Available in 12" or 15" two-way configurations and enhanced with dedicated low-frequency systems, EVF loudspeakers match exceptional audio performance, efficiency, ease-of-use and aesthetics with unprecedented value. EVF systems incorporate the latest Electro-Voice components to ensure years of reliability and exceptional sound. "S" designated systems are equipped with SMX series symmetric drive woofers and ND2B 2" titanium compression drivers; upgraded "D" high definition systems are equipped with our highest performance DVX series symmetric drive woofers and the DH7N 3" pure titanium compression driver.

EVF two-way full-range systems are offered in seven coverage patterns that provide solutions for the widest possible range of installation challenges. The 12" Constant Directivity waveguides can be rotated to work with a vertical or horizontal orientation. Biamp operation is supported, but the sophisticated fourth-order crossover and protection network makes cost-saving, passive operation extremely attractive. Using optional rigging accessories, you can create attractive clusters that include EVF full-range systems, as well as EVF subwoofers or EVH full-range systems. Cabinets are available in three finishes: EVCoat (interior use), PI (indirect weather exposure) or FG (fiberglass—for direct weather exposure); they include twenty-two M10 threaded suspension points.

EVF "S" STANDARD SERIES

EVF-1122S

12" TWO-WAY FULL-RANGE LOUDSPEAKERS



- 2" ND2B titanium HF compression driver
- Rotatable Constant Directivity waveguide
- Six available patterns with coverage from 60° to 120°
- 98 dB sensitivity, 131 dB maximum SPL
- Power handling: 500 W continuous, 2000 W peak
- Fourth-order passive crossover with HF protection
- Trapezoidal 13-ply birch enclosure in three finishes: EVCoat, PI and FG
- Four M10 metric eyebolts included

EVF-1152S

15" TWO-WAY FULL-RANGE LOUDSPEAKERS



- 2" ND2B titanium HF compression driver
- Rotatable Constant Directivity waveguide
- Six available patterns with coverage from 40° to 90°
- 101 dB sensitivity, 134 dB maximum SPL
- Power handling: 500 W continuous, 2000 W peak
- Fourth-order crossover with HF protection
- Trapezoidal 13-ply birch enclosure in three finishes: EVCoat, PI and FG
- Four M10 metric eyebolts included

See page 48–49 for EVF Rigging and Accessories.

EVF STANDARD 12" TWO-WAY SYSTEMS

| | EVF-1122S/64 | EVF-1122S/66 | EVF-1122S/94 | EVF-1122S/96 | EVF-1122S/99 | EVF-1122S/126 |
|---|---|--------------|--------------|--------------|--------------|---------------|
| Frequency Response (-3 dB) | 58–16,000 Hz ^{1,2} | | | | | |
| Frequency Range (-10 dB) | 49–19,000 Hz ^{1,2} | | | | | |
| Recommended High-Pass Frequency | 65 Hz | | | | | |
| Sensitivity (SPL, 1 W/1 m) | 98 dB | | | | | |
| Max. SPL @ 1 m (calc.) | 131 dB | | | | | |
| System Power Handling (Continuous ³ , Program, Peak) | 500 W, 1000 W, 2000 W | | | | | |
| Nominal Impedance (Passive) | 8 Ω | | | | | |
| Minimum Impedance | 6 Ω | | | | | |
| Input Connections | Euroblock; PI and FG versions include dual-gland-nut input-panel cover | | | | | |
| Coverage (Nominal -6 dB) H° x V° | 60° x 40° | 60° x 60° | 90° x 40° | 90° x 60° | 90° x 90° | 120° x 60° |
| LF Transducer | 12" SMX2121 driver | | | | | |
| HF Transducer | 2" ND2B diaphragm compression driver | | | | | |
| Internal Passive Crossover Frequency | 1,450 Hz | | | | | |
| Enclosure Material | 13-ply weather-resistant birch | | | | | |
| Grille | Standard versions: 16 ga Galvanneal, Powdercoat with screen behind PI and FG versions: 18 ga Stainless, Powdercoat with hydrophobic cloth behind | | | | | |
| Environmental | Standard versions: IEC 60529 IP44 PI and FG versions: IEC 60529 IP55 | | | | | |
| Suspension | 22 M10 threaded suspension points (one EBK-M10-EVI kit of four forged eyebolts included) | | | | | |
| Dimensions (H x W x D) | 30.26" x 16" x 16.27" (768.6 x 406.3 x 413.3 mm) | | | | | |
| Net Weight | 63.1 lb (28.6 kg) | | | | | |

¹ Half-space measurement in passive mode² FG (full outdoors) versions have no enclosure vents, somewhat reducing their low frequency response³ EIA RS-426A (eight hours)

EVF STANDARD 15" TWO-WAY SYSTEMS

| | EVF-1152S/43 | EVF-1152S/64 | EVF-1152S/66 | EVF-1152S/94 | EVF-1152S/96 | EVF-1152S/99 |
|---|---|--------------|--------------|--------------|--------------|--------------|
| Frequency Response (-3 dB) | 70–14,000 Hz ^{1,2} | | | | | |
| Frequency Range (-10 dB) | 41–18,000 Hz ^{1,2} | | | | | |
| Recommended High-Pass Frequency | 45 Hz | | | | | |
| Sensitivity (SPL, 1 W/1 m) | 101 dB | | | | | |
| Max. SPL @ 1 m (calc.) | 134 dB | | | | | |
| System Power Handling (Continuous ³ , Program, Peak) | 500 W, 1000 W, 2000 W | | | | | |
| Nominal Impedance (Passive) | 8 Ω | | | | | |
| Minimum Impedance | 6 Ω | | | | | |
| Input Connections | Euroblock; PI and FG versions include dual-gland-nut input-panel cover | | | | | |
| Coverage (Nominal -6 dB) H° x V° | 40° x 30° | 60° x 40° | 60° x 60° | 90° x 40° | 90° x 60° | 90° x 90° |
| LF Transducer | 15" SMX2151 driver | | | | | |
| HF Transducer | 2" ND2B diaphragm compression driver | | | | | |
| Internal Passive Crossover Frequency | 1,450 Hz | | | | | |
| Enclosure Material | 13-ply weather-resistant birch | | | | | |
| Grille | Standard versions: 16 ga Galvanneal, Powdercoat with screen behind PI and FG versions: 18 ga Stainless, Powdercoat with hydrophobic cloth behind | | | | | |
| Environmental | Standard versions: IEC 60529 IP44 PI and FG versions: IEC 60529 IP55 | | | | | |
| Suspension | 22 M10 threaded suspension points (one EBK-M10-EVI kit of four forged eyebolts included) | | | | | |
| Dimensions (H x W x D) | 30.26" x 18.5" x 18.37" (768.6 x 469.8 x 466.6 mm) | | | | | |
| Net Weight | 70.9 lb (32.1 kg) | | | | | |

¹ Half-space measurement in passive mode² FG (full outdoors) versions have no enclosure vents, somewhat reducing their low frequency response³ EIA RS-426A (eight hours)



EVF

EVF "D" HIGH DEFINITION SERIES

EVF "D" high definition systems are equipped with our highest performance DVX series symmetric drive woofers and the DH7N 3" pure titanium compression driver.

The result is lower distortion, cleaner sound reproduction at a given output level, compared with the equivalent "S" version.

EVF-1122D

HIGH DEFINITION 12" TWO-WAY FULL-RANGE LOUDSPEAKERS



- 3" DH7N titanium/neodymium HF compression driver
- Rotatable Constant Directivity waveguide
- Six available patterns with coverage from 60° to 120°
- 97 dB sensitivity, 131 dB maximum SPL
- Power handling: 600 W
- continuous, 2400 W peak
- Fourth-order passive crossover with HF protection
- Trapezoidal 13-ply birch enclosure in three finishes: EVCoat, PI and FG
- 22 M10 threaded suspension points
- Transformer kit available for distributed systems
- Four M10 metric eyebolts included

EVF-1152D

HIGH DEFINITION 15" TWO-WAY FULL-RANGE LOUDSPEAKERS



- Compact and lightweight
- Low distortion, high efficiency
- Ideal for fixed installations
- DVX3151A woofer with fully symmetric drive
- 3" DH7N titanium/neodymium HF compression driver
- Rotatable Constant Directivity waveguide
- Six available patterns with coverage from 40° to 90°
- 100 dB sensitivity, 134 dB maximum SPL
- Power handling: 600 W continuous, 2400 W peak
- Fourth-order crossover with HF protection
- Trapezoidal 13-ply birch enclosure in three finishes: EVCoat, PI and FG
- 22 M10 threaded suspension points
- Transformer kit available for distributed systems
- Four M10 metric eyebolts included

See page 48–49 for EVF Rigging and Accessories.



EVF HIGH DEFINITION 12" TWO-WAY SYSTEMS

| | EVF-1122D/64 | EVF-1122D/66 | EVF-1122D/94 | EVF-1122D/96 | EVF-1122D/99 | EVF-1122D/126 |
|---|---|--------------|--------------|--------------|--------------|---------------|
| Frequency Response (-3 dB) | 57–18,000 Hz ^{1,2} | | | | | |
| Frequency Range (-10 dB) | 49–21,000 Hz ^{1,2} | | | | | |
| Recommended High-Pass Frequency | 65 Hz | | | | | |
| Sensitivity 1 W/1 m | 97 dB | | | | | |
| Max. SPL/1 m (Calculated) ¹ | 131 dB | | | | | |
| System Power Handling (Continuous ³ , Program, Peak) | 600 W, 1200 W, 2400 W | | | | | |
| Nominal Impedance (Passive) | 8 Ω | | | | | |
| Minimum Impedance | 6 Ω | | | | | |
| Input Connections | Euroblock; PI and FG versions include dual-gland-nut input-panel cover | | | | | |
| Coverage (Nominal -6 dB) H° x V° | 60° x 40° | 60° x 60° | 90° x 40° | 90° x 60° | 90° x 90° | 120° x 60° |
| LF Transducer | 12" DVX3121A woofer | | | | | |
| HF Transducer | 3" DH7N diaphragm compression driver | | | | | |
| Internal Passive Crossover Frequency | 1,300 Hz | | | | | |
| Enclosure Material | 13-ply weather-resistant birch | | | | | |
| Grille | Standard versions: 16 ga Galvanneal, Powdercoat with screen behind PI and FG versions: 18 ga Stainless, Powdercoat with hydrophobic cloth behind | | | | | |
| Environmental | Standard versions: IEC 60529 IP44 PI and FG versions: IEC 60529 IP55 | | | | | |
| Suspension | 22 M10 threaded suspension points (one EBK-M10-EVI kit of four forged eyebolts included) | | | | | |
| Dimensions (H x W x D) | 30.26" x 16.00" x 16.27" (768.6 x 406.3 x 413.3 mm) | | | | | |
| Net Weight | 65.5 lb (29.7 kg) | | | | | |

¹ Half-space measurement in passive mode

² FG (full outdoors) versions have no enclosure vents, somewhat reducing their low frequency response

³ EIA RS-426A (eight hours)

EVF HIGH DEFINITION 15" TWO-WAY SYSTEMS

| | EVF-1152D/43 | EVF-1152D/64 | EVF-1152D/66 | EVF-1152D/94 | EVF-1152D/96 | EVF-1152D/99 |
|---|---|--------------|--------------|--------------|--------------|--------------|
| Frequency Response (-3 dB) | 70–18,000 Hz ^{1,2} | | | | | |
| Frequency Range (-10 dB) | 40–21,000 Hz ^{1,2} | | | | | |
| Recommended High-Pass Frequency | 45 Hz | | | | | |
| Sensitivity 1 W/1 m | 100 dB | | | | | |
| Max. SPL/1 m (Calculated) ¹ | 134 dB | | | | | |
| System Power Handling (Continuous ³ , Program, Peak) | 600 W, 1200 W, 2400 W | | | | | |
| Nominal Impedance (Passive) | 8 Ω | | | | | |
| Minimum Impedance | 6 Ω | | | | | |
| Input Connections | Euroblock; PI and FG versions include dual-gland-nut input-panel cover | | | | | |
| Coverage (Nominal -6 dB) H° x V° | 40° x 30° | 60° x 40° | 60° x 60° | 90° x 40° | 90° x 60° | 90° x 90° |
| LF Transducer | 15" DVX3151A woofer | | | | | |
| HF Transducer | 3" DH7N diaphragm compression driver | | | | | |
| Internal Passive Crossover Frequency | 1,300 Hz | | | | | |
| Enclosure Material | 13-ply weather-resistant birch | | | | | |
| Grille | Standard versions: 16 ga Galvanneal, Powdercoat with screen behind PI and FG versions: 18 ga Stainless, Powdercoat with hydrophobic cloth behind | | | | | |
| Environmental | Standard versions: IEC 60529 IP44 PI and FG versions: IEC 60529 IP55 | | | | | |
| Suspension | 22 M10 threaded suspension points (one EBK-M10-EVI kit of four forged eyebolts included) | | | | | |
| Dimensions (H x W x D) | 30.26" x 18.5" x 18.37" (768.6 x 469.8 x 466.6 mm) | | | | | |
| Net Weight | 75.7 lb (34.4 kg) | | | | | |

¹ Half-space measurement in passive mode

² FG (full outdoors) versions have no enclosure vents, somewhat reducing their low frequency response

³ EIA RS-426A (eight hours)

EVF Subwoofers



A range of acoustically and aesthetically matched front-loaded low-frequency systems are available to compliment your full-range systems. Cabinet heights are the same as those of EVF and EVH full-range loudspeakers systems, so you can create functional, attractive clusters using these low-frequency boxes with almost any combination of EVF and EVH loudspeakers.

EVF-1121S 12" FRONT-LOADED BASS ELEMENT



- Enhanced bass for installations
- Low-distortion EVS12SB woofer
- 99 dB sensitivity, 131 dB maximum SPL
- Power: 400 W continuous, 1600 W peak
- Trapezoidal 13-ply birch enclosure
- EVCoat, PI or FG finish
- 22 M10 threaded suspension points
- Four M10 metric eyebolts included

EVF-1151S 15" FRONT-LOADED BASS ELEMENT



- Enhanced bass for installations
- Low-distortion EVS15SB woofer
- 99 dB sensitivity, 131 dB maximum SPL
- Power: 400 W continuous, 1600 W peak
- Trapezoidal 13-ply birch enclosure
- EVCoat, PI or FG finish
- 22 M10 threaded suspension points
- Four M10 metric eyebolts included

EVF-1181S 18" FRONT-LOADED SUBWOOFER



- Ideal for installations
- Low-distortion EVS18SB woofer
- 99 dB sensitivity, 131 dB maximum SPL
- Power: 400 W continuous, 1600 W peak
- Trapezoidal 13-ply birch enclosure
- EVCoat, PI or FG finish
- 28 M10 threaded suspension points
- Four M10 metric eyebolts included

EVF-2121S DUAL 12" FRONT-LOADED SUBWOOFER



- Ideal for installations
- Low-distortion dual EVS18SB woofer
- 100 dB sensitivity, 135 dB maximum SPL
- Power: 800 W continuous, 3200 W peak
- Trapezoidal 13-ply birch enclosure
- EVCoat, PI or FG finish
- 22 M10 threaded suspension points
- Four M10 metric eyebolts included

EVF-2151D

DUAL 15" FRONT-LOADED SUBWOOFER



- High power handling for installations
- Two premium DVX3159A woofers
- 101 dB sensitivity, 137 dB maximum SPL
- Power: 1000 W continuous, 4000 W peak
- Trapezoidal 13-ply birch enclosure
- EVCoat, PI or FG finish
- 28 M10 threaded suspension points
- Four M10 metric eyebolts included

See page 48–49 for EVF Sub Rigging and Accessories.



LOUDSPEAKERS

CONCERT

INSTALL

PORTABLE PA

| | EVF-1121S | EVF-1151S | EVF-2121S | EVF-1181S | EVF-2151D |
|---|---|--|--|--|--|
| Frequency Response (-3 dB) | 70–98 Hz ^{1/2} | 67–95 Hz ^{1/2} | 54–145 Hz ^{1/2} | 35–100 Hz ^{1/2} | 40–2,600 Hz ^{1/2} |
| Frequency Range (-10 dB) | 48–120 Hz ^{1/2} | 46–124 Hz ^{1/2} | 41–330 Hz ^{1/2} | 28–650 Hz ^{1/2} | 30–3,200 Hz ^{1/2} |
| Recommended High-Pass Frequency | 50 Hz | 35 Hz | 45 Hz | 33 Hz | 35 Hz |
| Internal Passive Low-Pass Filter | 100 Hz, 12 dB per octave | 100 Hz, 12 dB per octave | None | None | None |
| Sensitivity (SPL, 1 W/1 m) | 99 dB | 99 dB | 100 dB | 99 dB | 101 dB |
| Max. SPL @ 1 m (calc.) | 131 dB | 131 dB | 135 dB | 131 dB | 137 dB |
| System Power Handling (Continuous ³ , Program, Peak) | 400 W, 800 W, 1600 W | 400 W, 800 W, 1600 W | 800 W, 1600 W, 3200 W | 400 W, 800 W, 1600 W | 1000 W, 2000 W, 4000 W |
| Nominal Impedance | Passive: 4 Ω, Biamp: 8 Ω | Passive: 4 Ω, Biamp: 8 Ω | Passive: N/A, Biamp: 4 Ω | Passive: N/A, Biamp: 8 Ω | Passive: N/A, Biamp: 4 Ω |
| Minimum Impedance | Passive: 3.4 Ω, Biamp: 5.5 Ω | Passive: 3.4 Ω, Biamp: 6.4 Ω | Passive: N/A, Biamp: 2.8 Ω | Passive: N/A, Biamp: 6 Ω | Passive: N/A, Biamp: 2.7 Ω |
| Input Connections | Euroblock; PI and FG versions include dual gland nut input panel cover | | | | |
| Coverage (Nominal -6 dB) | Omnidirectional in normal operating range | | | | |
| Transducer | 12" EVS12SB driver | 15" EVS15SB driver | Two 12" EVS12SB driver | 18" EVS18SB driver | Two 15" DVX3159A drivers |
| Enclosure Material | 13-ply weather-resistant birch | | | | |
| Grille | Standard versions: 16 ga Galvanneal, Powdercoat with screen behind PI and FG versions: 18 ga Stainless, Powdercoat with hydrophobic cloth behind | | | | |
| Environmental | Standard versions: IEC 60529 IP44 PI and FG versions: IEC 60529 IP55 | | | | |
| Suspension | 22 M10 threaded suspension points (one EBK-M10-EVI kit of four forged eyebolts included) | | | 28 M10 threaded suspension points (one EBK-M10-EVI kit of four forged eyebolts included) | |
| Dimensions (H x W x D) | 30.26" x 16.0" x 16.27" (768.6 x 406 x 413.3 mm) | 30.26" x 18.5" x 18.4" (768.6 x 470 x 467 mm) | 30.26" x 18.5" x 18.4" (768.6 x 470 x 467 mm) | 30.26" x 26.6" x 28.6" (768.6 x 675.6 x 726.4 mm) | 30.26" x 26.6" x 28.6" (768.6 x 675.6 x 726.4 mm) |
| Net Weight | 577 lb (26.2 kg) | 62.6 lb (28.4 kg) | 82.4 lb (37.4 kg) | 101.2 lb (45.9 kg) | 117 lb (53.1 kg) |



The EVH series is a dedicated installed sound solution that builds on everything Electro-Voice has learned about full-range, horn-loaded systems. Delivering exceptional value in venues of all sizes, these mid-sized 15" two-way cabinets feature a unique coaxial horn-loaded design that is unmatched for pattern control and intelligibility in reverberant environments.

A 400-W SMX2151 woofer provides the EVH's deep, rich lows, while horn loading extends directivity control below 500 Hz. High frequencies are handled by a pure titanium compression driver—either a standard 2" ("S" models) or a premium 3" with neodymium magnetic structure (high

definition "D" models)—protected by an advanced fourth-order crossover network. Six coverage patterns (ranging from 40° x 30° to 90° x 90°) on rotatable Constant Directivity waveguides offer extraordinary versatility.

Three finishes are available, including two for outdoor applications. EVH loudspeakers come installation-ready with 28 M10-threaded suspension points, making rigging extremely flexible. Wherever extended pattern control is a priority, the EVH series provides a proven, effective solution.

EVH systems are mechanically compatible with the EVF subs.

EVH-1152S

TWO-WAY COAXIAL HORN-LOADED FULL-RANGE LOUDSPEAKERS



- Ideal for reverberant spaces
- Pattern control maintained below 500 Hz
- 15" SMX2151 woofer
- 2" ND2B titanium HF compression driver
- Rotatable Constant Directivity waveguide
- Six available coverage patterns from 40° x 30° to 90° x 90°
- 106 dB sensitivity, 139 dB maximum SPL
- Power handling: 500 W continuous, 2000 W peak
- Fourth-order passive crossover with HF protection
- Trapezoidal enclosure in three finishes: EVCoat, PI or FG
- 28 M10 threaded suspension points
- Four M10 metric eyebolts included

EVH-1152D

HIGH DEFINITION TWO-WAY COAXIAL HORN-LOADED FULL-RANGE LOUDSPEAKERS



- Ideal for reverberant spaces
- Pattern control maintained below 500 Hz
- 15" SMX2151 woofer
- 3" DH7N titanium/neodymium HF compression driver
- Rotatable Constant Directivity waveguide
- Six available coverage patterns from 40° x 30° to 90° x 90°
- 106 dB sensitivity, 139 dB maximum SPL
- Power handling: 500 W continuous, 2000 W peak
- Fourth-order passive crossover with HF protection
- Trapezoidal enclosure in three finishes: EVCoat, PI or FG
- 28 M10 threaded suspension points
- Four M10 metric eyebolts included

See page 48–49 for EVH Rigging and Accessories.

EVH STANDARD TWO-WAY SYSTEMS

| | EVH-1152S/43 | EVH-1152S/64 | EVH-1152S/66 | EVH-1152S/94 | EVH-1152S/96 | EVH-1152S/99 |
|---|---|--------------|--------------|--------------|--------------|--------------|
| Frequency Response (-3 dB) | 60–15,000 Hz ¹ | | | | | |
| Frequency Range (-10 dB) | 50–16,000 Hz ¹ | | | | | |
| Recommended High-Pass Frequency | 60 Hz | | | | | |
| Sensitivity (SPL, 1 W/1 m) | 106 dB | 105 dB | 105 dB | 105 dB | 105 dB | 104 dB |
| Max. SPL @ 1 m (calc.) | 139 dB | 138 dB | 138 dB | 138 dB | 138 dB | 137 dB |
| System Power Handling (Continuous ² , Program, Peak) | 500 W, 1000 W, 2000 W | | | | | |
| Nominal Impedance (Passive) | 8 Ω | | | | | |
| Minimum Impedance | 6 Ω | | | | | |
| Input Connections | Euroblock; PI and FG versions include dual-gland-nut input-panel cover | | | | | |
| Coverage (Nominal -6 dB) H° x V° | 40° x 30° | 60° x 40° | 60° x 60° | 90° x 40° | 90° x 60° | 90° x 90° |
| LF Transducer | 15" SMX2151 driver | | | | | |
| HF Transducer | 2" ND2B diaphragm compression driver | | | | | |
| Internal Passive Crossover Frequency | 1,300 Hz | | | | | |
| Enclosure Material | 13-ply weather-resistant birch | | | | | |
| Grille | Standard versions: 16 ga Galvanneal, Powdercoat with screen behind PI and FG versions: 18 ga Stainless, Powdercoat with hydrophobic cloth behind | | | | | |
| Environmental | Standard versions: IEC 60529 IP33 PI and FG versions: IEC 60529 IP55 | | | | | |
| Suspension | 28 M10 threaded suspension points (one EBK-M10-EVI kit of four forged eyebolts included) | | | | | |
| Dimensions (H x W x D) | 30.26" x 30.26" x 26.77" (768.6 x 768.6 x 680.1 mm) | | | | | |
| Net Weight | 143 lb (64.9 kg) | | | | | |

EVH HIGH DEFINITION TWO-WAY SYSTEMS

| | EVH-1152D/43 | EVH-1152D/64 | EVH-1152D/66 | EVH-1152D/94 | EVH-1152D/96 | EVH-1152D/99 |
|---|---|--------------|--------------|--------------|--------------|--------------|
| Frequency Response (-3 dB) | 60–17,000 Hz ¹ | | | | | |
| Frequency Range (-10 dB) | 50–20,000 Hz ¹ | | | | | |
| Recommended High-Pass Frequency | 60 Hz | | | | | |
| Sensitivity (SPL, 1 W/1 m) | 106 dB | 105 dB | 105 dB | 105 dB | 105 dB | 104 dB |
| Max. SPL @ 1 m (calc.) | 139 dB | 138 dB | 138 dB | 138 dB | 138 dB | 137 dB |
| System Power Handling (Continuous ² , Program, Peak) | 500 W, 1000 W, 2000 W | | | | | |
| Nominal Impedance (Passive) | 8 Ω | | | | | |
| Minimum Impedance | 6 Ω | | | | | |
| Input Connections | Euroblock; PI and FG versions include dual-gland-nut input-panel cover | | | | | |
| Coverage (Nominal -6 dB) H° x V° | 40° x 30° | 60° x 40° | 60° x 60° | 90° x 40° | 90° x 60° | 90° x 90° |
| LF Transducer | 15" SMX2151 driver | | | | | |
| HF Transducer | 3" DH7N diaphragm compression driver | | | | | |
| Internal Passive Crossover Frequency | 1,300 Hz | | | | | |
| Enclosure Material | 13-ply weather-resistant birch | | | | | |
| Grille | Standard versions: 16 ga Galvanneal, Powdercoat with screen behind PI and FG versions: 18 ga Stainless, Powdercoat with hydrophobic cloth behind | | | | | |
| Environmental | Standard versions: IEC 60529 IP33 PI and FG versions: IEC 60529 IP55 | | | | | |
| Suspension | 28 M10 threaded suspension points (one EBK-M10-EVI kit of four forged eyebolts included) | | | | | |
| Dimensions (H x W x D) | 30.26" x 30.26" x 26.77" (768.6 x 768.6 x 680.1 mm) | | | | | |
| Net Weight | 145.5 lb (66.1 kg) | | | | | |

¹ Half-space measurement in passive mode² EIA RS-426A (eight hours)



EVA

The Expandable Vertical Array (EVA) series is a vertical line array with a unique, elegant system design that provides a simple solution for installed sound applications. EVA offers true line array performance and coherent far-field summing from the patented Hydra plane wave generator. The internal, hidden rigging not only looks great, but also makes EVA incredibly easy to install. The sophisticated internal crossover lets you power up to eight EVA full-range

modules (16 line array elements) from a single amplifier channel, eliminating the need for external crossovers or DSP. The four full-range modules in the series are complemented by two matching subwoofers that can be flown in the array. If you think that your budget isn't big enough for a great sounding line array, EVA may be just the answer you're looking for.

Features:

- High performance, cost-effective
- Ideal for fixed installation line arrays
- Two array elements in each module
- Two 8" low-distortion woofers
- Four 1.25" titanium diaphragm HF drivers
- Advanced Hydra plane wave generators
- Constant Directivity waveguide
- High sensitivity (104 dB) for high output
- Super efficient: drive up to 8 boxes from a single amp channel
- Sixth-order passive crossover with HF protection
- Integrated hidden suspension hardware
- Choice of three finishes: indoor, PI and FG
- EVADA (EVA Design Assistant) software tool

EVA-2082S 126



DUAL-ELEMENT
120° BY 6°
FULL-RANGE LINE-
ARRAY MODULE

EVA-2082S 1220



DUAL-ELEMENT
120° BY 20°
FULL-RANGE LINE-
ARRAY MODULE

EVA-2082S 906



DUAL-ELEMENT
90° BY 6° FULL-RANGE
LINE-ARRAY MODULE

EVA-2082S 920



DUAL-ELEMENT
90° BY 20° FULL-RANGE
LINE-ARRAY MODULE

EVA SUBWOOFERS

Features:

- High power, front loaded
- Ideal for fixed installations
- Seamless rigging with EVA line arrays
- DVX3159A woofer for low distortion at high SPL
- Steel-reinforced 13-ply birch enclosure

EVA-1151D 15" SUBWOOFER LINE ARRAY ELEMENT



- DVX3159A woofer for low distortion at high SPL
- 98 dB sensitivity (1 W/1 m half space)
- Power handling: 500 W continuous, 2000 W peak
- 125/131 dB maximum SPL (continuous/peak)
- Integrated hidden suspension hardware
- Splays of 0° or 5° between modules
- Choice of three finishes: EVCoat, PI and FG

EVA-2151D DUAL 15" SUBWOOFER LINE ARRAY ELEMENT



- Two DVX3159A woofers for low distortion at high SPL
- 100 dB sensitivity (1 W/1 m half space)
- Power handling: 1000 W continuous, 4000 W peak
- 130/136 dB maximum SPL (continuous/peak)
- Choice of two finishes: EVCoat and PI (EVA-2151D not available in FG version)

See page 48–49 for EVA Rigging and Accessories.

| | EVA-2082S 1220 | EVA-2082S 126 | EVA-2082S 906 | EVA-2082S 920 | EVA-1151D | EVA-2151D |
|---|---|--|--|---|--|--|
| Frequency Response (-3 dB) | 60–19000 Hz | | | | 48–250 Hz (half space) | 38–200 Hz (half space) |
| Recommended High-Pass Frequency | 50 Hz | | | | 35 Hz, 24 dB per Octave BW | 32 Hz, 24 dB per Octave BW (half space) |
| Sensitivity (SPL, 1 W/1 m) | 104 dB (3 module array) | | | | 98 dB, Arithmetic average, 55–100 Hz (half space) | 100 dB, Arithmetic average, 55–100 Hz (half space) |
| Max. SPL @ 1 m (calc.) | 135 dB | | | | 131 dB (half space) | 130/133/136 dB (half space) |
| System Power Handling (Continuous, Program, Peak) | 350, 700, 1400 W | | | | 500 W, 1000 W, 2000 W | 1000 W, 2000 W, 4000 W |
| Nominal Impedance (Passive) | 16 Ω | | | | 8 Ω | 4 Ω |
| Input Connections | Euroblock | | | | | |
| Frequency Range (-10 dB) | 45–20,000 Hz | | | | 35–250 Hz (half space) | 28–200 Hz (half space) |
| Coverage (Nominal -6 dB) H° | 120° | 120° | 90° | 90° | Omnidirectional | Omnidirectional |
| Coverage (Nominal -6 dB) V° | 20° | 6° | 6° | 20° | Omnidirectional | Omnidirectional |
| LF Transducer | Two 8" EVS2008 drivers | | | | DVX3159A | Two DVX3159A |
| HF Transducer | Four 1.25" DH2005 diaphragm compression driver | | | | None | None |
| Crossover Frequency | 1,740 Hz | | | | 100 Hz active | 100 Hz active |
| Minimum Impedance | 12 Ω | | | | 5.8 Ω | 2.8 Ω |
| Enclosure Material | Birch plywood | | | | | |
| Grille | 16 ga Galvanneal, powder-coated; PI Version: stainless steel with hydrophobic cloth | | | | | |
| Suspension | EVA grid (sold separately) | | | | | |
| Dimensions (H x W x D) | 20.17" x 23.5" x 14.53" (512.2 x 596.9 x 369.1 mm) | 20.25" x 23.5" x 14.1" (514.4 x 596.9 x 358.2 mm) | 20.25" x 23.5" x 14.1" (514.4 x 596.9 x 358.2 mm) | 20.17" x 23.5" x 14.53" (512.2 x 596.9 x 369.1 mm) | 23.5" x 23.5" x 18.16" (596.9 x 596.9 x 461.3 mm) | 30.5" x 23.42" x 31.2" (930.4 x 597 x 792.5 mm) |
| Net Weight | 81.0 lb (36.8 kg) | 81.8 lb (37.1 kg) | 81.8 lb (37.1 kg) | 81.0 lb (36.8 kg) | 89.1 lb (40.4 kg) | 178 lb (80.8 kg) |



EVU

Bringing ultracompact design to the EV Innovation family of installation loudspeakers, the EVU series shines in applications including delay, under-balcony fill, front-fill, wall mounting and distributed audio. EVU loudspeakers feature a rotatable Constant Directivity waveguide that provides truly uniform sound dispersion while allowing the horizontal coverage pattern to be independent of enclosure

orientation. Sonically matched to complement the other EV Innovation products, EVU helps make EV Innovation the industry's most comprehensive and versatile line of installed-sound loudspeakers.

A fourth-order, 90 Hz high-pass filter is recommended for use with all EVU loudspeakers.

Features:

- Sonically matched to all EV-Innovation lines
- Sophisticated 18-dB-octave passive crossover/EQ networks
- Asymmetrical enclosure for ideal under-balcony and stage-lip aiming
- Optional NL4-type connector panel
- One 1.3" diaphragm compression driver
- U-bracket included
- Optional 70 V and 100 V operation
- OmniMount®-compatible rear mounting points
- Available in black or white (interior use)

EVU-1062/95

ULTRACOMPACT TWO-WAY WITH SINGLE 6.5" WOOFER



- Ultracompact 8 x 14.5" enclosure
- 90° x 50° rotatable Constant Directivity waveguide
- Ultra-high power handling for size: 160 W continuous
- 120 dB maximum SPL
- Asymmetrical trapezoidal enclosure design
- Compatible with OmniMount™

EVU-2062/95

ULTRACOMPACT TWO-WAY WITH DUAL 6.5" WOOFERS



- Ultracompact 8 x 21" enclosure
- 90° x 50° rotatable Constant Directivity waveguide
- Ultra-high power handling for size: 300 W continuous
- 125 dB maximum SPL
- Asymmetrical trapezoidal enclosure design
- Compatible with OmniMount™

EVU-1082/95



ULTRACOMPACT TWO-WAY WITH SINGLE 8" WOOFER

- Ultracompact 10 x 16" enclosure
- 90° x 50° rotatable Constant Directivity waveguide
- Ultra-high power handling for size: 175 W continuous
- 123 dB maximum SPL
- Asymmetrical trapezoidal enclosure design
- Compatible with OmniMount™

EVU-2082/95



ULTRACOMPACT TWO-WAY WITH DUAL 8" WOOFERS

- Ultracompact 10 x 24" enclosure
- 90° x 50° rotatable Constant Directivity waveguide
- Ultra-high power handling for size: 350 W continuous
- 126 dB maximum SPL
- Asymmetrical trapezoidal enclosure design
- Compatible with OmniMount™

See page 49 for EVU Rigging and Accessories.

| | EVU-1062/95 | EVU-2062/95 | EVU-1082/95 | EVU-2082/95 |
|--------------------------------------|---|---|---|---|
| Frequency Response (-3 dB) | 110-16,000 Hz ¹ | 100-16,000 Hz ¹ | 110-16,000 Hz ¹ | 100-16,000 Hz ¹ |
| Frequency Response (-10 dB) | 65-20,000 Hz ¹ | 70-20,000 Hz ¹ | 65-20,000 Hz ¹ | 60-20,000 Hz ¹ |
| Recommended High-Pass Frequency | 90 Hz | 90 Hz | 90 Hz | 90 Hz |
| Axial Sensitivity (1 W/1 m) | 92 dB | 94 dB | 95 dB | 95 dB |
| Maximum SPL (calc.) Continuous, Peak | 114, 120 dB | 119, 125 dB | 117, 123 dB | 120, 126 dB |
| Waveguide | 6" x 6", rotatable | 6" x 6", rotatable | 6" x 6", rotatable | 6" x 6", rotatable |
| Horizontal Coverage | 90° | 90° | 90° | 90° |
| Vertical Coverage | 50° | 50° | 50° | 50° |
| Power Handling (Continuous, Peak) | 160, 640 W ² | 300, 1200 W ² | 175, 700 W ² | 350, 1400 W ² |
| LF Transducer | 6.5" ICT-6.5-8 woofer | Two 6.5" ICT-6.5-8 woofers | 8" ICT-8-8 woofer | Two 8" ICT-8-8 woofers |
| HF Transducer | 1.3" diaphragm ICT-1-8 compression driver | 1.3" diaphragm ICT-1-8 compression driver | 1.3" diaphragm ICT-1-8 compression driver | 1.3" diaphragm ICT-1-8 compression driver |
| Nominal Impedance | 8 Ω | 8 Ω | 8 Ω | 8 Ω |
| Minimum Impedance | 6 Ω | 6 Ω | 6 Ω | 6 Ω |
| Connectors | 4-pin Euroblock (up to 10 AWG wire) | 4-pin Euroblock (up to 10 AWG wire) | 4-pin Euroblock (up to 10 AWG wire) | 4-pin Euroblock (up to 10 AWG wire) |
| Enclosure Material | 9-ply hardwood plywood | 9-ply hardwood plywood | 9-ply hardwood plywood | 9-ply hardwood plywood |
| Minimum Impedance | Textured paint | Textured paint | Textured paint | Textured paint |
| Color | Black or white | Black or white | Black or white | Black or white |
| Grille, Standard Versions | 18 ga steel with cloth behind | 18 ga steel with cloth behind | 18 ga steel with cloth behind | 18 ga steel with cloth behind |
| Suspension | Six M8 threaded points | Six M8 threaded points | Six M8 threaded points | Six M8 threaded points |
| Dimensions (H x W x D) | 8.21" x 14.6" x 8.14" (209 x 370 x 207 mm) | 8.21" x 21.0" x 8.14" (209 x 533 x 207 mm) | 9.73" x 16.1" x 9.34" (247 x 409 x 237 mm) | 9.73" x 24.2" x 9.34" (247 x 615 x 237 mm) |
| Net Weight | 14.4 lb (6.53 kg) | 25.0 lb (11.3 kg) | 16.3 lb (7.40 kg) | 28.3 lb (12.8 kg) |

¹ Half-space measurement
² EIA RS-426A (eight hours)



EVI

EVI provides a simple, economical solution for permanent installations requiring even coverage over a fixed rectangular area. In a typical room, the distance from a front-mounted loudspeaker to the last row is two or more times the distance to the front row, resulting in a substantial front-to-back difference in level and

intelligibility. The Variable Intensity horn counters this problem by increasing the sound sent to the back of the room by six to eight dB, balancing SPL distribution without the expense and complexity of additional systems or components.

EVI-12

12" TWO-WAY VARIABLE INTENSITY LOUDSPEAKER



- Variable Intensity horn for even coverage
- Two-way, full-range loudspeaker
- High sensitivity
- Vented LF enclosure
- 1.25" HF driver with titanium diaphragm
- PRO™ Driver protection circuit
- Multi-angled housing
- Five 3/8" hanging points

EVI-15

15" TWO-WAY VARIABLE INTENSITY LOUDSPEAKER



- Variable Intensity horn for even coverage
- Two-way, full-range loudspeaker
- High sensitivity
- Vented LF enclosure
- 1.25" HF driver with titanium diaphragm
- PRO™ Driver protection circuit
- Multi-angled housing
- Five 3/8" hanging points

EVI-28

DUAL 8" TWO-WAY VARIABLE INTENSITY LOUDSPEAKER



- Ideal for reverberant spaces
- Variable Intensity horn for even coverage
- Two-way, full-range loudspeaker
- Vented LF enclosure
- 1.25" HF driver with titanium diaphragm
- PRO™ Driver protection circuit
- Multi-angled housing
- Stacked, frequency-shaded woofers for pattern control down to 500 Hz
- Three 3/8" hanging points

See page 49 for EVI Rigging and Accessories.

EVI VARIABLE INTENSITY COVERAGE PATTERN (3-2-1 RULE):

If speaker mount-height = H, then coverage length = 3H, coverage width = 2H and first row coverage = 1H

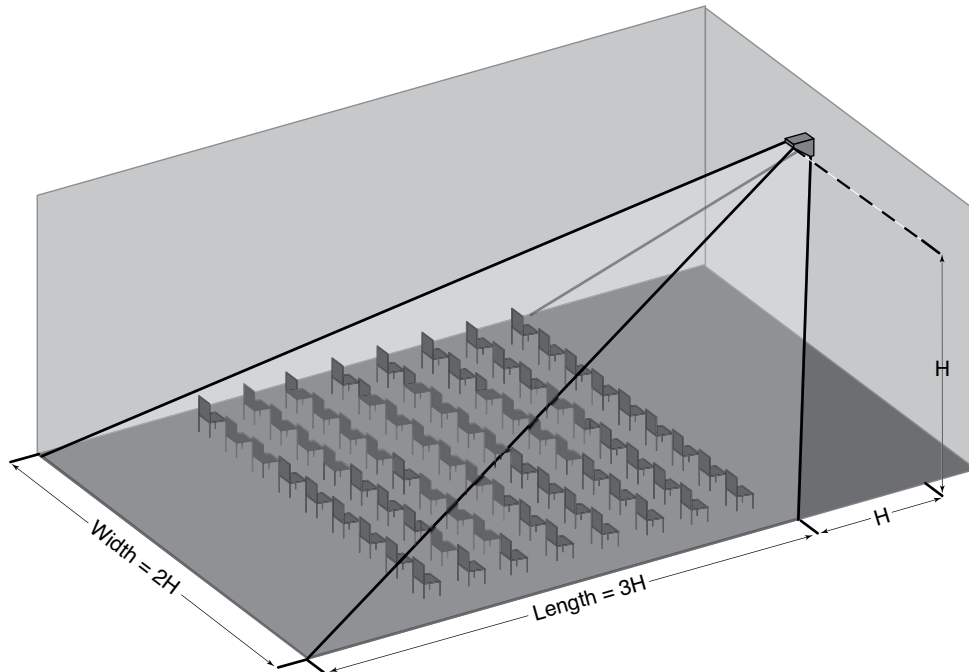

LOUDSPEAKERS

CONCERT

INSTALL

PORTABLE PA

| | EVI-12 | EVI-15 | EVI-28 |
|-----------------------------------|--|--|--|
| Frequency Response (-10 dB) | 50–20,000 Hz | 50–20,000 Hz | 60–20,000 Hz |
| Sensitivity (SPL 1 W/1 m) | 99 dB | 100 dB | 93 dB |
| Max. SPL/1m (calc.) | 129 dB | 130 dB | 123 dB |
| Power Handling (Continuous, Peak) | 250 W, 1000 W | 250 W, 1000 W | 250 W, 1000 W |
| Coverage, H x V | 60° x 70° long throw, 110° x 90° short throw | 65° x 65° long throw, 110° x 65° short throw | 65° x 65° long throw, 110° x 65° short throw |
| LF Transducer | 12" | 15" | Two 8" |
| HF Transducer | 1.25" DH3/2010A compression driver (1" exit) | 1.25" DH3/2010A compression driver (1" exit) | 1.25" DH3/2010A compression driver (1" exit) |
| Crossover frequency | 2,000 Hz | 2,000 Hz | 2,000 Hz |
| Nominal impedance (minimum) | 8 Ω | 8 Ω | 8 Ω |
| Input connections | Screw terminal | Screw terminal | Screw terminal |
| Dimensions (H x W at front x D) | 21.8" x 14" x 27.5" (554 x 356 x 699 mm) | 23" x 16.9" x 30.2" (584 x 429 x 766 mm) | 13.9" x 19.5" x 20.6" (353 x 496 x 523 mm) |
| Net Weight | 48 lb (21.8 kg) | 53 lb (24.0 kg) | 36 lb (16.3 kg) |

EVID



EVID SURFACE-MOUNT SYSTEMS

EVID premium commercial loudspeakers bring best-in-class sonic characteristics and stunning high fidelity to a broad range of installation applications, including performance and sports venues, retail environments, conference and meeting rooms, and hospitality settings, such as restaurants and bars. Available in both flush-mount

and surface-mount configurations, EVID loudspeakers feature innovative designs that beautify not only the sound of a room but also its looks. EVID 3.2, 4.2 and 6.2 models are available in "T"-designated versions with internal 70 or 100 V line transformer. High power and high performance, EVID is the superior solution to today's installation needs.

EVID 3.2

DUAL 3.5" TWO-WAY SURFACE-MOUNT LOUDSPEAKER



- Ultra-compact full range
- Ideal for restaurants, bars, patios and retail
- Vented LF enclosure
- 0.75" titanium diaphragm HF driver with neodymium magnetic structure
- Full-bandwidth overload protection (LF and HF)
- Elliptical weather-resistant ABS enclosure
- Paintable black or white finish
- Magnetically shielded for video applications
- Strong-Arm Mount for easy, flexible aiming
- "T" version for 70 or 100 V distributed systems

EVID 4.2

DUAL 4" TWO-WAY SURFACE-MOUNT LOUDSPEAKER



- Compact full range
- Ideal for restaurants, bars, patios and retail
- Vented LF enclosure
- 1" titanium diaphragm HF driver with neodymium magnetic structure
- Coherent Coverage Waveguide
- Full-bandwidth overload protection (LF and HF)
- Elliptical weather-resistant ABS enclosure
- Paintable black or white finish
- Magnetically shielded for video applications
- Strong-Arm Mount for easy, flexible aiming
- "T" version for 70 or 100 V distributed systems

EVID 6.2

DUAL 6" TWO-WAY SURFACE-MOUNT LOUDSPEAKER



- Compact full range
- Ideal for shopping malls, sports bars and health clubs
- Vented LF enclosure
- 1" titanium diaphragm HF driver with neodymium magnetic structure
- Coherent Coverage Waveguide
- Full-bandwidth overload protection (LF and HF)
- Elliptical weather-resistant ABS enclosure
- Paintable black or white finish
- Magnetically shielded for video applications
- Strong-Arm Mount for easy, flexible aiming
- "T" version for 70 or 100 V distributed systems

EVID 3.2, EVID 4.2 AND EVID 6.2

INCLUDED

EV's Strong-Arm Mount (SAM) comes with each EVID system and includes a hex-key-tool. SAM has angle markers to make installation easier.

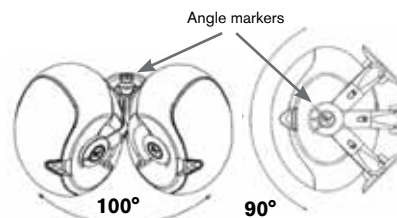

EVID 12.1

12" CORNER-MOUNT, DUAL VOICE COIL SUBWOOFER



- Supplemental bass for indoor systems
- Ideal for sports bars, dance floors, retail and health clubs
- High-excursion woofer with dual voice coil to accommodate L/R channels
- High sensitivity, high power-handling
- Crossed-over pass-thru for up to four satellite speakers
- Trapezoidal shape for flexible placement and optimal bass loading
- Steel-reinforced cabinet with mounting hardware included
- Paintable black or white finish
- One 3/8" 16-thread forged steel eyebolt is included. A second is necessary for hanging.
- The mounting bracket passes EIA 636 at a safety factor of 8:1 and included for on-wall or corner mounting.

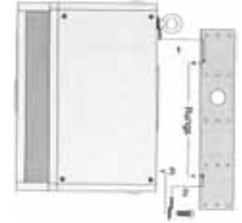

EVID IN-WALL SPEAKER SYSTEMS

EVID FM 4.2

4" TWO-WAY FLUSH-MOUNT LOUDSPEAKER



- Shallow profile, ideal for tight wall or ceiling spaces
- Tuned passive radiator extends bass, enhances performance
- High quality 1" titanium dome tweeter
- Full-bandwidth overload protection
- 70 V, 100 V and 8 Ω operation in the same model for off-the-shelf versatility
- Front-panel mode/wattage switch
- Fully-sealed enclosure provides superior isolation to protect adjacent rooms
- Secure Phoenix-style pass-through connectors for easy wiring and installation
- Four point "quick mounting" tabs for fast attachment in any wall cavity
- Can-mounted transformer for enhanced rigidity
- Ribbed back can eliminates flexing

EVID FM 6.2

6" TWO-WAY FLUSH-MOUNT LOUDSPEAKER



- Shallow profile, ideal for tight wall or ceiling spaces
- Tuned passive radiator extends bass, enhances performance
- High quality 1" titanium dome tweeter
- Full-bandwidth overload protection
- 70 V, 100 V and 8 Ω operation in the same model for off-the-shelf versatility
- Front-panel mode/wattage selector
- Fully-sealed enclosure provides superior isolation to protect adjacent rooms
- Secure Phoenix-style pass-through connectors for easy wiring and installation.
- Four point "quick mounting" tabs for fast attachment in any wall cavity
- Can-mounted transformer for enhanced rigidity
- Ribbed back can eliminates flexing

See page 49 for EVID Rigging and Accessories.

| | EVID 3.2 | EVID 4.2 | EVID 6.2 | EVID 12.1 | EVID FM 4.2 | EVID FM 6.2 |
|---|--|---|---|--|---|---|
| Frequency Range (-10 dB) | 85–20,000 Hz | 65–20,000 Hz | 62–20,000 Hz | 40–140 Hz | 52–20,000 Hz | 52–20,000 Hz |
| Sensitivity (SPL, 1 W/1 m) | 87 dB | 89 dB | 94 dB | 100 dB (1/4 space) | 87 dB | 90 dB |
| Max. SPL/1m (calc.) | 112 dB | 115 dB | 122 dB | 128 dB (1/4 space) | 110 dB | 115 dB |
| Power Handling (Continuous, Peak) | 75 W, 300 W | 100 W, 400 W | 150 W, 600 W | 175 W, 700 W (per coil) | 50 W, 200 W | 75 W, 300 W |
| Transformer taps (transformer version only) | 70 V: 5 W 100 V: 10 W | 70 V: 3.75 W 70 V/100 V: 7.5, 15, 30 W | 70 V: 7.5 W 70 V/100 V: 15, 30, 60 W | — | 70 V: 1.75, 3.75, 7.5, 15, 30 W | 70 V: 7.5, 15, 30, 60 W |
| Coverage, H x V | 140° x 100° | 120° x 80° | 100° x 80° | — | 150° x 150° | 120° x 120° |
| LF Transducer | Two 3.5" | Two 4" | Two 6" | 12" | 4", plus 4" passive radiator | 6", plus 6" passive radiator |
| HF Transducer | 0.75" | 1" | 1" | — | 1" (titanium dome) | 1" (titanium dome) |
| Nominal impedance (non-transformer version) | 8 Ω | 8 Ω | 8 Ω | 8 Ω | 8 Ω | 8 Ω |
| Minimum impedance (non-transformer version) | 6 Ω | 6 Ω | 6 Ω | 6 Ω | — | — |
| Input connections | Spring terminal | Spring terminal | Spring terminal | Spring terminal | 4-pin Phoenix | 4-pin Phoenix |
| Dimensions (H x W at front x D) | 9.2" x 5.1" x 6.5" (234 x 127 x 165 mm) | 12.2" x 6.9" x 8.5" (234 x 127 x 165 mm) | 16.5" x 9" x 11.75" (419 x 228 x 298 mm) | 16.25" x 23" x 12" (412 x 584 x 305 mm) | 13.78" x 7.41" x 3.76" (350 x 188.3 x 95.6 mm) | 18.31" x 10.08" x 3.95" (465 x 256 x 100.3 mm) |
| Net Weight (incl. mounting bracket) | 3.3 lb (1.5 kg) | 8.5 lb (3.9 kg) | 12 lb (5.3 kg) | 40 lb (18.1 kg) | 6.39 lb (2.9 kg) | 12.79 lb (5.8 kg) |

LOUDSPEAKERS

CONCERT

INSTALL

PORTABLE PA

EVID



Designed with both the contractor and listener in mind, EVID ceiling speakers are high-performance problem-solvers that deliver exceptional sound in even the most challenging situations. From the compact power of the C4.2 to the exclusive waveguide-coupled design of the C8.2HC, each great-sounding EVID solution is uniquely suited to

handle installer needs across a specific range of intended applications. Sonically superior and aesthetically pleasing, every EVID ceiling model installs with ease and provides lasting value. For commercial sound across all venue types, EVID has the ceiling covered.

EVID C4.2

4" TWO-WAY COAXIAL CEILING LOUDSPEAKER



- Designed for use in air-handling spaces
- Ported enclosure for extended bass response
- Waveguide-coupled 0.75" titanium-coated tweeter
- Full-bandwidth overload protection
- Integrated transformer for 70 V, 100 V or 8 Ω use
- Front-panel mode/wattage selector
- Safe, easy installation with included tile bridge and mounting ring
- Available in black or white
- Complete package, requires no additional accessories

EVID C8.2 EVID C8.2LP

8" TWO-WAY COAXIAL CEILING LOUDSPEAKER



- Ported enclosure for extended bass response
- Waveguide-coupled 1" titanium-coated tweeter
- Full-bandwidth overload protection
- Integrated transformer for 70 V, 100 V or 8 Ω use
- Front-panel mode/wattage selector
- Safe, easy installation with included tile bridge and mounting ring
- Complete package, requires no additional accessories
- Low-profile LP version delivers rich sound in tight spaces
- EVID C8.2 available in black or white

EVID C8.2HC

8" PATTERN-CONTROL TWO-WAY COAXIAL CEILING LOUDSPEAKER



- Maximum fidelity and intelligibility for high ceilings
- Ported enclosure for extended bass response
- Waveguide-coupled 1" titanium-coated tweeter
- Full-bandwidth overload protection
- Integrated transformer for 70 V, 100 V or 8 Ω use
- Front-panel mode/wattage selector
- Safe, easy installation with included tile bridge and mounting ring
- White semi-gloss perforated grille
- Complete package, requires no additional accessories

EVID C10.1

10" HIGH-POWER CEILING SUBWOOFER



- Supplemental LF for ceiling systems
- High-excursion woofer in ported enclosure for extended lows
- Low pass network with overload protection
- Integrated transformer for 70 V, 100 V or 8 Ω use
- Front-panel mode/wattage selector
- Internally damped heavy-gauge steel enclosure
- Safe, easy installation with included tile bridge and mounting ring
- White semi-gloss perforated grille
- Complete package, requires no additional accessories

EVID C12.2

12" TWO-WAY COAXIAL CEILING LOUDSPEAKER



- Full-range power for high ceilings, large spaces
- High sensitivity, high power-handling
- Integrated transformer with automatic saturation compensation for distortion-free 70 V, 100 V or 8 Ω use
- Front-panel mode/wattage selector
- White semi-gloss perforated grille
- Heavy-gauge steel enclosure in black
- 3/8" threaded-rod mount points for open ceilings
- Safe, easy installation with included tile bridge and mounting ring
- Complete package, requires no additional accessories

| | EVID C4.2 | EVID C8.2 EVID C8.2LP | EVID C8.2HC | EVID C.12.2 | EVID C10.1 |
|------------------------------|---------------------------------------|---|--------------------------------------|--|--|
| Frequency Range (-10 dB) | 65–20,000 Hz | 50–20,000 Hz | 50–20,000 Hz | 65–20,000 Hz | 45–180 Hz |
| Sensitivity (SPL, 1 W @ 1 m) | 86 dB | 91 dB | 93 dB | 100 dB | 94 dB |
| Power Handling (8 Ω) | 80 W (overload protected) | 100 W (overload protected) | 100 W (overload protected) | 100 W | 150 W |
| Coverage Pattern | 130° conical | 110° conical | 75° conical (@ > 1 kHz) | 90° average | 180° |
| Transformer Power Taps | 1.88 (70 V only), 3.75, 7.5, 15, 30 W | 1.88 (70 V only), 3.75, 7.5, 15, 30 W | 7.5 (70 V only), 15, 30, 60 W | 4 (70 V only), 8, 16, 32, 64 W ASC protected | 7.5 (70 V only), 15, 30, 60 W |
| LF Transducer | 4" polypropylene cone | 8" polypropylene cone | 8" polypropylene cone plus waveguide | 12" EVID 920-8B (coax) | 10" polypropylene cone |
| HF Transducer | 0.75" Ti Mylar Laminate Dome | 1" Ti Mylar Laminate Dome | 1" Ti Mylar Laminate Dome | 1" coax | — |
| Input Configuration | 8 Ω, 70 V, 100 V | 8 Ω, 70 V, 100 V | 8 Ω, 70 V, 100 V | 8 Ω / 70 V / 100 V | 8 Ω, 70 V, 100 V |
| Dimensions (H x Diameter) | 6.93" x 7.13" (176 x 181 mm) | 7.01" x 10.65" (178 x 270 mm) 10.04" x 10.63" (255 x 270 mm) | 11.99" x 12.60" (303 x 320 mm) | 13.18" x 16.3" (333 x 414 mm) | 11.99" x 12.60" (303 x 320 mm) |
| Net Weight | 6.0 lb (2.7 kg) | 11.0 lb (5.0 kg) | 13.2 lb (6.0 kg) | 27.12 lb (12.3 kg) | 15.4 lb (7.0 kg) |
| Acoustic Design | | Ported cabinet, internally damped, two-way (passive crossover included) | | | Dual ported cabinet, internally damped |
| Cabinet Construction | | Steel enclosure and UL94V-0 rated baffle and bezel | | | |
| Mounting System | | Integrated 3-point toggle anchors | | | |
| Grille Construction | | Powder-coated steel | | | |
| Available Colors | | White (paintable surface) | | | |



Specialty Loudspeakers

S-40

ULTRACOMPACT 5.25" TWO-WAY FULL-RANGE LOUDSPEAKER



Delivering high performance in an ultra-compact package, the S-40 is ideal for both distributed and near-field applications requiring high-quality sound. The two-way short-throw system is housed in an optimally vented, high-impact polystyrene enclosure that is suited for installation both indoors and out. Lows are handled by a 5.25" direct-radiating woofer with a polypropylene cone, while the high-frequency section is a

1" direct-radiating soft-dome tweeter that is ferrofluid cooled. Built-in automatic power limiting independently protects each driver from unsafe transients. With mounting options that are flexible enough for virtually any application, the S series is perfect for anything from background and foreground music in restaurants and clubs to near-field monitoring in control rooms and broadcast studios.

- Ideal for both distributed and near-field applications
- Designed for indoor and outdoor use
- Direct-radiating polypropylene-cone woofer
- 1" ferrofluid-cooled soft-dome tweeter
- High power-handling, ultra-linear frequency response
- Vented trapezoidal enclosure of high-impact polystyrene
- Passive crossover with power protection for both woofer and tweeter
- OmniMount®-compatible 0.25" suspension points (2)

FRI-2082 FRI-28LPM

DUAL 8" TWO-WAY FULL-RANGE LOUDSPEAKER



This speaker remains one of our most popular choices for speech reinforcement, for under-balcony and on-wall locations in permanent installations, and as a high-quality monitor system. Dual 8" drivers in a tuned enclosure are matched to a 1" titanium compression driver with a 100° x 100° Constant Directivity waveguide.

The FRI-2082 comes with a mounting bracket for horizontal or vertical orientation, while the FRI-28LPM has non-skid rubber mounting feet to make it more appropriate for stage monitoring.

- Ultra-compact LF-optimized vented enclosure
- 1" HF driver on Constant Directivity waveguide
- 100° H x 100° V coverage pattern
- Low-profile slanted design
- Versatile 45° aiming angle for under-balcony, on-wall and stage monitoring applications
- Mounting bracket included (FRI-2082 only)
- Two 3/8" suspension points

| | S-40 |
|---|---------------------------------------|
| Frequency Response (+/- 3 dB) | 85–20,000 Hz |
| Sensitivity (SPL, 1 W @ 1 m) | 85 dB |
| Max. SPL / 1 m (calc.) | 113 dB |
| Power handling (Long-term, Short-term) | 120 W, 480 W |
| Coverage, H x V | 100° x 100° |
| Directivity Index | 9.8 dB (+3.8/-3.6 dB), 2–20,000 Hz |
| LF Transducer | 5.25" |
| HF Transducer | 1" softdome |
| Crossover frequencies | 3,500 Hz |
| Nominal impedance (low Z version) | 4 Ω |
| Minimum impedance (low Z version) | 3.7 Ω |
| Input connections | Spring terminal |
| Dimensions (H x W at front x D) | 9.8" x 7" x 5.9" (249 x 178 x 150 mm) |
| Net Weight (including mounting bracket) | 5.7 lb (2.6 kg) |

| | FRI-2082 & FRI-28LPM |
|---|--|
| Frequency Response (- 3dB) | 70–20,000 Hz |
| Frequency Range (-10 dB) | 55–16,000 Hz |
| Recommended High-Pass Frequency | 50 Hz (12 dB/octave) |
| Axial Sensitivity, Biamp (SPL, 1 W @ 1 m) | 93 dB |
| Max. SPL / 1 m (calc., full space) | 122 dB |
| Power Handling, Biamp (Continuous, Peak) | 200 W, 800 W |
| Coverage (nominal -6 dB) H x V | 100° x 100° (Const. Dir. waveguide) |
| LF Transducer | Two 8" |
| HF Transducer | 1" compression driver |
| Crossover Frequency | 2,800 Hz |
| Nominal Impedance (Biamp) | 8 Ω |
| Input Connections | Barrier strip |
| Dimensions (H x W at front x D) | 8.75" x 24.5" x 14" (222 x 620 x 356 mm) |
| Net Weight | 40 lb (18.2 kg) |

See page 50 for S-40 and page 47 for FRI-2082 Rigging and Accessories.

Monitors

CONCERT MONITORS

Our top-of-the-line floor monitors, originally designed as part of the X-Array touring line.

- Two-way, high-output design
- Vented LF enclosure
- Two symmetrical 55° enclosure angles
- Ultracompact for all-size stages

Xw12A 12" TWO-WAY FLOOR MONITOR



- DL12ST woofer with Ring-Mode Decoupling for vocal clarity

TOUR X FLOOR MONITORS

- Compact with high output
- Ideal for small-to-medium stages
- Signal Synchronized Transducers™ for woofer/tweeter alignment
- Low-distortion SMX2121 woofer with fully symmetric drive
- 1.25" DH3/2010A titanium HF compression driver

TX1122FM 12" TWO-WAY FULL-RANGE MONITOR



- Low-distortion SMX2121 woofer with fully symmetric drive
- 99 dB sensitivity, 132 dB maximum SPL

| | Xw12A | Xw15A |
|---|---|---|
| Frequency Response (-3 dB) | 65 Hz – 18 kHz | 55–18,000 Hz |
| Recommended High-Pass Frequency | System controller determined | System controller determined |
| Axial Sensitivity (SPL, 1 W @ 1 m), LF/HF | 98/110 dB | 99/110 dB |
| Max. SPL @ 1 m (calc), full space, LF/HF | 129/135 dB | 133/135 dB |
| Long-Term Power Handling, LF/HF | 300/75 W | 600/75 W |
| Short-Term Power Handling (peak), LF/HF | 1200/300 W | 2400/300 W |
| Coverage (nominal -6 dB) H° x V° | 55° x 80° (Const. Dir. waveguide) | 55° x 80° (Const. Dir. waveguide) |
| Directivity Index | 11.6 dB (+2.3/-2.1 dB) 1,200–16,000 Hz | 11.6 dB (+3.0/-3.6 dB) 1,200–16,000 Hz |
| LF woofer (transducer) | 12" DL12ST | 15" EVX155 |
| HF throat diameter (transducer) | 1.4" ND6-16 | 1.4" ND6-16 |
| Crossover Frequencies | Factory preset | Factory preset |
| Nominal Impedance, LF/HF | 8 Ω/16 Ω | 8 Ω/16 Ω |
| Minimum Impedance, LF/HF | 8.2 Ω/10.5 Ω | 7.2 Ω/14.3 Ω |
| Input Connections | 2 four-pin Speakon | 2 four-pin Speakon |
| Dimensions in floor position (H x W at front x D) | 23" x 17.2" x 12.2" (534 x 449 x 313 mm) | 25.4" x 18" x 13.4" (644 x 452 x 340 mm) |
| Net Weight | 48 lb (21.9 kg) | 62.5 lb (28.4 kg) |

See page 40 for Tour X Loudspeakers.

- 3" ND6-16 titanium/neodymium HF compression driver
- 80° x 55° Constant Directivity waveguide
- Neutrik Speakon paralleled pass-through connectors on each end
- Two integrated handles

Xw15A 15" TWO-WAY FLOOR MONITOR



- EVX155 woofer with 4" voice coil

- 90° H x 50° V Constant Directivity waveguide
- Integrated 24 dB/octave crossover with HF protection
- 99 dB sensitivity, 132 dB maximum SPL
- Power handling: 500 W continuous, 2000 W peak
- Black EVCoat finish

TX1152FM 15" TWO-WAY FULL-RANGE MONITOR



- Ultra low-distortion SMX2151 woofer with fully symmetric drive
- 100 dB sensitivity, 133 dB maximum SPL

| | TX1122FM | TX1152FM |
|--|---|---|
| Speaker Type | Full-range | Full-range |
| Frequency Response (-3 dB) | 70 Hz – 20 kHz | 65 Hz – 20 kHz |
| Frequency Range (-10 dB) | 55 Hz – 20 kHz | 45 Hz – 20 kHz |
| Sensitivity (SPL, 1 W/1 m) | 99 dB (1w/1m) | 100 dB |
| Max. SPL/1m (calc) | 132 dB | 133 dB |
| System Power Handling (Continuous, Peak) | 500 W, 2000 W | 500 W, 2000 W |
| Coverage (Nominal -6 dB) | 90° H x 50° V | 90° H x 50° V |
| LF Transducer | 12" SMX2121 | 15" SMX2151 |
| HF Transducer | 1.25" DH3/2010A | 1.25" DH3/2010A |
| Internal Crossover | Yes | Yes |
| Crossover Frequency | 1,600 Hz | 1,750 Hz |
| Nominal Impedance (Passive) | 8 Ω | 8 Ω |
| Minimum Impedance | 6.4 Ω | 6.2 Ω |
| Input Connections | Parallel Neutrik NL4 | Parallel Neutrik NL4 |
| Enclosure Material | Plywood and MDF with EVCoat | Plywood and MDF with EVCoat |
| Flying Suspension | Six 3/8" threaded inserts | Six 3/8" threaded inserts |
| Dimensions (H x W x D) | 17.3" x 14.3" x 22.6" (440 x 364 x 573 mm) | 18.7" x 17.3" x 25.8" (475 x 439 x 655 mm) |
| Net Weight | 43.7 lb (19.8 kg) | 51.9 lb (23.5 kg) |



Designed for top-notch quality with amazing versatility, the ZX/ZXA series sets a new standard of performance and practicality in sound reinforcement loudspeakers. Featuring high-end components and lightweight molded enclosures, the ZX/ZXA line is at home in any installed or portable application, from commercial sound to clubs, houses of worship, stages, arenas and stadiums. Newly-designed high-power woofers and drivers ensure full-range sound

with awesome richness and clarity. Sleek contemporary styling fits in anywhere. Lightweight makes transport easy while enabling a multitude of flying and mounting options that are each supported by innovative mechanical solutions. Whether for portable use or permanent installation, the ZX/ZXA series represents the next level in advanced loudspeaker technology.

ZX1

8" TWO-WAY FULL-RANGE COMPOSITE LOUDSPEAKER



- Smooth, wide frequency response
- Ideal for mains, fills or monitors
- Velocity-compensated port for exceptional LF
- Long-excursion weather-treated EV8L woofer
- 1.25" DH2005 titanium HF compression driver
- Rotatable 90° x 50° waveguide for flexible coverage
- Passive crossover with full-band overload protection
- High sensitivity, 123 dB maximum SPL
- Power handling: 200 W continuous, 800 W peak
- High-impact polypropylene enclosure
- Compact monitor-friendly wedge shape
- Integrated pole mount adapter and pocket handle
- Four Metric mounting inserts
- Available in black or white

ZX1i

8" TWO-WAY FULL-RANGE INDOOR/OUTDOOR LOUDSPEAKER



- Install version of the ZX1
- Indoor/outdoor design
- Ideal for installed mains, fills or distributed sound
- Velocity-compensated port for exceptional LF
- Long-excursion weather-treated EV8L woofer
- 1.25" DH2005 titanium HF compression driver
- Choice of 90° x 50° or 100° x 100° rotatable waveguide
- Passive crossover with full-band overload protection
- Also available in 70/100 volt transformer version with Electro-Voice patented ASC (Automatic Saturation Compensation)
- High sensitivity, 123 dB maximum SPL
- Power handling: 200 W continuous, 800 W peak
- Compact high-impact polypropylene enclosure
- Integrated QuickSAM heavy-duty Strong-Arm Mounting bracket
- Paintable black or white finish

ZX1-SUB

12" POWERED SUBWOOFER



- 15 mm plywood enclosure, internally braced, with textured paint
- EVS-12S 12" woofer for powerful, engaging bass response
- Pole mount for full-range systems

ZX3

12" TWO-WAY FULL-RANGE LOUDSPEAKER



- Versatile performance for mains, fills or monitors
- DVX3121A woofer with forced-air cooling
- 2" ND2 titanium/neodymium HF driver
- Passive crossover
- Choice of 90° x 50° or 60° x 60° coverage waveguide
- High sensitivity, 131 dB maximum SPL
- Power handling: 600 W continuous, 2400 W peak
- High-impact polypropylene enclosure
- Compact monitor-friendly wedge shape
- Up to four anchor-plate attachments
- Seven M8 mounting inserts
- Integrated handle
- Available in black and white

ZX4 15" TWO-WAY FULL-RANGE LOUDSPEAKER

- Perfect for portable mains and monitors
- EVS15-SF woofer
- 1.25" DH3/2010A titanium HF driver
- Passive crossover
- 90° x 50° coverage waveguide
- High sensitivity, 132 dB maximum SPL
- Power handling: 400 W continuous, 1600 W peak
- Lightweight high-impact polypropylene enclosure
- Wedge shape for monitors at 45° or 55°
- Integrated pole mount adapter and pocket handle
- Mounting via attachment plates or eyebolts
- Black finish

ZX5 ALL-WEATHER 15" TWO-WAY FULL-RANGE LOUDSPEAKER

- Versatile performance for mains, fills or monitors
- DVX3150A woofer with forced-air cooling
- 2" ND2 titanium/neodymium HF driver
- Switchable biamp or passive crossover operation
- Choice of 90° x 50° or 60° x 60° coverage waveguide
- High sensitivity, 132 dB maximum SPL
- Power handling: 600 W continuous, 2400 W peak
- High-impact polypropylene enclosure
- Wedge shape for monitors at 45° or 55°
- Up to five anchor-plate attachments
- Ten M8 mounting inserts
- Integrated handle
- Available in black or white

ZXA1 POWERED 8" TWO-WAY FULL-RANGE LOUDSPEAKER

- Powered ZX1, ideal for portable and monitor use
- Integrated 800 W 2-channel (biamp) amplifier
- Long-excursion weather-treated EV8L woofer
- 1.25" DH2005 titanium HF compression driver
- Rotatable 90° x 50° waveguide for flexible coverage
- Steep crossover slopes and transducer protection
- 123 dB maximum SPL
- Microphone and line level inputs
- Switchable high-pass filter for use with subwoofer
- Compact wedge-shape enclosure of lightweight impact-resistant polystyrene
- Integrated pole mount adapter and pocket handle
- Four #8-32 suspension points for installation
- Available in black or white

ZXA1-SUB 12" POWERED SUBWOOFER

- 15 mm plywood enclosure, internally braced, with textured paint
- EVS-12S 12" woofer for powerful, engaging bass response
- Class D lightweight amplifier
- Pole mount for full-range systems
- Dual XLR inputs and outputs
- Switchable EQ modes for different applications
- LED indicators for power on and limit

ZXA5 POWERED 15" TWO-WAY FULL-RANGE LOUDSPEAKER

- Ideal for both portable and installation use
- Integrated 2-channel amplifier, 1000 W LF, 250 W HF
- DVX3150A woofer with forced-air cooling
- 2" ND2 titanium/neodymium HF driver
- 90° x 50° coverage waveguide
- High sensitivity, 133 dB maximum SPL
- Switchable high-pass filter for use with subwoofer
- PowerCon connector with slave through
- Compact enclosure of high-impact polypropylene
- Wedge shape for monitors at 45° or 55°
- Integrated handle
- Up to five anchor-plate attachments
- Ten M8 mounting inserts
- Available in black or white



| | ZX1 | ZX1i | ZX1-SUB | ZX3 | ZX4 | ZX5 | ZXA1 | ZXA5 | ZXA1-SUB |
|-----------------------------------|--|---|---|--|--|--|---|---|---|
| Speaker Type | Full-range, mid-high, two-way, wedges | Full-range, mid-high, two-way | Passive Subwoofer | Full-range | Full-range, mid-high, two-way, wedges | Full-range, mid-high, two-way, wedges | Full-range, powered monitors, powered speakers, two-way, wedges | | Powered Subwoofer |
| Frequency Response (-3 dB) | 60–20,000 Hz | 60–20,000 Hz | 53–125 Hz ¹ | 58–15,000 Hz | 60–20,000 Hz | 58–18,000 Hz | 60–20,000 Hz (full-range mode) | 58–18,000 Hz | 53–93 Hz ¹ |
| Frequency Range (-10 dB) | 48–20,000 Hz | 48–20,000 Hz | 42–200 Hz ¹ | 48–20,000 Hz | 42–20,000 Hz | 39–20,000 Hz | 48–20,000 Hz (full-range mode) | 50–20,000 Hz | 44–118 Hz ¹ |
| Sensitivity (SPL, 1 W/1 m) | 94 dB | 94 dB | 94 dB | 97 dB | 100 dB | 98 dB | — | — | — |
| Max. SPL/1m (calc) | 123 dB | 123 dB | 127 dB ^{1,2} | 131 dB | 132 dB | 132 dB | 123 dB | 133 dB | 126 dB ^{1,2} |
| Power Handling (Continuous, Peak) | 200, 800 W | 200, 800 W | 400 W Cont, 800 W Prog, 1600 W Peak | 600, 2400 W | 400, 1600 W | 600, 2400 W | — | — | 700 W |
| Coverage (Nominal -6 dB) | 90° x 50° rotatable | 90° x 50° rotatable 100° x 100° rotatable | Omnidirectional | 90° H x 50° V 60° H x 60° V | 90° H x 50° V | 90° H x 50° V 60° H x 60° V | 90° x 50° rotatable | 90° H x 50° V 60° H x 60° V | Omnidirectional |
| LF Transducer | 8" EV8L | 8" EV8L | 12" EVS-12S Woofer | 12" DVX3121A | 15" EVS15-SF | 15" DVX3150A | 8" EV8L | 15" DVX3150A | 12" EVS-12S Woofer |
| HF Transducer | 1.25" DH2005 | 1.25" DH2005 | — | 2" ND2 | 1.25" DH3/2010A | 2" ND2 | 1.25" DH2005 | 2" ND2 | — |
| Recommended High-Pass Frequency | 40 Hz | 40 Hz | — | 50 Hz | 42 Hz | 36 Hz | 36 Hz | 100 Hz (user selectable) | — |
| Nominal Impedance (Passive) | 8 Ω | 8 Ω | 8 Ω | 8 Ω | 8 Ω | 8 Ω | — | — | — |
| Input Connections | Parallel Neutrik NL4 Speakon | 4-pin Phoenix | Two NL4 | 2 conductor SJO cable and gland nut | Parallel Neutrik NL4 | Parallel Neutrik NL4 | XLR and TRS Combo; XLR with Independent Gain | | Two XLR Stereo Input |
| Internal Crossover | Yes | Yes | — | Yes | Yes | Switchable biamp or passive crossover | — | — | — |
| Crossover Frequency | 1.7 kHz | 1.7 kHz | — | 2 kHz | 1,500 Hz | 1,500 Hz | 1,800 Hz | 1,500 Hz | 100 Hz |
| Minimum Impedance | 6 Ω | 6 Ω | 7.5 Ω | 6.2 Ω | 6.5 Ω | 6.5 Ω | — | — | — |
| Amplifier Power (RMS) | — | — | — | — | — | — | 800 W | 1250 W | 800 W |
| Power Requirement | — | — | — | — | — | — | 120V: 95V–132V, 50–60 Hz, 0.6A 230V: 190V–264V, 50–60 Hz, 0.4A | | 120V: 90V–132V, 50–60 Hz, 1.0A 230V: 190V–264V, 50–60 Hz, 0.6A |
| Enclosure Material | High-Impact Polystyrene | | 9-ply, 15 mm plywood, internally braced with textured paint | | | High-Impact Polystyrene | | 9-ply, 15 mm plywood, internally braced with textured paint | |
| Grille | Polyester Powder Coated, 18 ga Galvanized Steel | | 16 ga Steel with Black Powder Coat | | | Polyester Powder Coated, 18 ga Galvanized Steel | | 16 ga Steel with Black Powder Coat | |
| Flying | No | Yes | No | Yes | Yes | Yes | No | Yes | No |
| Outdoor | No | Yes | No | Yes | No | Yes | No | No | No |
| Color | Black | Black, white | Black | Black, white | Black | Black, white | Black | Black, white | Black |
| Dimensions (H x W x D) | 17.98" x 11.12" x 10.38" (457 x 282 x 264 mm) | 17.76" x 11.1" x 10.35" (451 x 282 x 263 mm) | 15.75" x 17.50" x 18.00" (400 x 444.5 x 457.2 mm) | 24.14" x 15.64" x 14.26" (613 x 397 x 362 mm) | 27.01" x 17.52" x 15.98" (686 x 445 x 406 mm) | 27.24" x 17.56" x 16.18" (692 x 446 x 411 mm) | 17.99" x 11.1" x 10.39" (457 x 282 x 264 mm) | 27.24" x 17.56" x 16.18" (692 x 446 x 411 mm) | 15.75" x 17.50" x 18.00" (400 x 444.5 x 457.2 mm) |
| Net Weight | 18.52 lb (8.4 kg) | 18.52 lb (8.4 kg) | 43.6 lb (19.8 kg) | 43.65 lb (19.8 kg) | 44.53 lb (20.2 kg) | 48.94 lb (22.2 kg) | 19 lb (8.62 kg) | 50.49 lb (22.9 kg) | 46.0 lb (20.9 kg) |

¹ Half-Space

² Typical maximum SPL value at one meter over the usable frequency range, measured with a pink-noise burst signal, using internal signal processing and amplifier driven to peak output.

EVM12L



Known for huge tone, gorgeous low-end and incredible stability at extreme volumes, the EVM12L Classic 12" musical instrument loudspeaker has been a favorite since its introduction in 1983. For an even louder, harder tone there's the EVM-12L Black Label, the official guitar loudspeaker of Zakk Wylde and Black Label Society, which

features improved power handling, magnet design and venting. Either way, guitarists and bassists love how tough the EVM12L sounds—and how tough it is. For the world's most punishing players, there's only one guitar speaker line that delivers the goods night after night, tour after tour: the Electro-Voice EVM-12L.

EVM12L Classic

WORLD'S GREATEST GUITAR LOUDSPEAKER



- Classic sound with road-ready reliability
- Favorite of guitarists in all styles
- High-performance heavy-duty design
- 200 W Power handling
- Frequency response: 80 Hz – 7 kHz (-10 dB)
- Heavy-duty cast frame for reduced low-frequency flex
- Large 16 lb (7.3 kg) magnet assembly
- Manufactured in the USA

EVM12L Black Label

ZAKK WYLDE SIGNATURE GUITAR SPEAKER



- Official guitar loudspeaker of Zakk Wylde and Black Label Society
- EVM-12L sound with enhanced magnet design and venting
- 300 W power handling
- Frequency response: 80 Hz – 7 kHz (-10 dB)
- Sensitivity 100 dB
- Large 16 lb (7.3 kg) magnet assembly
- Handmade in the USA

| | EVM12L Classic | EVM12L Black Label |
|--|-------------------|--------------------|
| Cone Diameter | 12" (305 mm) | 12" (305 mm) |
| Coil Diameter | 2.5" (63.5 mm) | 2.5" (63.5 mm) |
| Frequency Range | 80–7,000 Hz | 80–7,000 Hz |
| Power Handling: Continuous (EIA), Peak | 200, 1000 W | 300, 1200 W |
| Sensitivity (SPL, 1 W @ 1 m) | 100 dB | 100 dB |
| Maximum SPL | 125 dB | 125 dB |
| Efficiency | 5.9% | 5.9% |
| Impedance | 8 Ω | 8 Ω |
| Frame Front Diameter | 12.19" (309.6 mm) | 12.19" (309.6 mm) |
| Magnet Diameter | 7.5" (190.5 mm) | 7.5" (190.5 mm) |
| Overall Depth | 5.25" (133.4 mm) | 5.25" (133.4 mm) |
| Mounting Bolt Circle Diameter | 11.56" (293.7 mm) | 11.56" (293.7 mm) |
| Baffle Cutout Diameter | 11.06" (281.0 mm) | 11.06" (281.0 mm) |
| Net Weight | 19 lb (8.6 kg) | 19 lb (8.6 kg) |



The SX series includes some of the most popular loudspeaker designs in history. SX loudspeakers offer the tour-proven performance and reliability for which EV is known. A versatile range of speaker configurations and lightweight enclosures covers applications in commercial sound, pro music, club sound, and performance and sports venues. In live performance, the SX line can handle tasks, such as front-of-house, side fills, delay lines or stage monitors. For installed sound, easy mounting and

multiple weather-ready versions provide flexible system configuration for both indoor and outdoor venues. With high power-handling, great coverage, and smooth, consistent frequency response, cost-effective SX loudspeakers are the hard-working, easy-setup solution to your installation and portable system needs.

Sx300E

12" TWO-WAY FULL-RANGE LOUDSPEAKER



- Compact, portable sound reinforcement
- Designed for use alone or in arrays
- Cast-frame DL12BFH woofer
- 1.25" DH3/2010A titanium HF compression driver
- 65° x 65° Constant Directivity waveguide
- Ring-Mode Decoupling (RMD) for increased intelligibility
- Power handling: 300 W continuous, 1200 W peak
- Dual Neutrik Speakon high-current connectors
- Trapezoidal black or white polypropylene enclosure
- Rubber feet and mating sockets for stacking
- Integral handles, pole mount

**Sx300PI
Sx300PIX**

WEATHER-RESISTANT 12" TWO-WAY FULL-RANGE LOUDSPEAKERS



- Sx300 performance with enhanced weather-resistance
- PIX version has multi-tap transformer for 70 or 100 V use
- Ideal for installation, alone or in arrays
- 1.25" DH3/2010A titanium HF compression driver
- 65° x 65° Constant Directivity waveguide
- Ring-Mode Decoupling (RMD) for increased intelligibility
- Power handling: 300 W continuous, 1200 W peak
- Neutrik Speakon (PI) or Phoenix (PIX) connectors
- Trapezoidal enclosure of high-impact polypropylene
- Rubber feet and mating sockets for stacking
- Integral handles, pole socket, suspension points
- Available in black or white

See page 50 for Sx300 and SB122 Rigging and Accessories.

Sx600PI
Sx600PIX

WEATHER-RESISTANT DUAL-ELEMENT FULL-RANGE LINE ARRAY



- High output with exceptional outdoor performance
- Ideal for arenas, stadiums and race tracks
- 600 W multi-tap transformer (PIX only) for 70 or 100 V use
- High intelligibility at high SPL (139 dB max)
- Cast-frame 12" DL12BFH woofer
- Neodymium-based 12" ND12A mid-driver
- 2" DH2T titanium HF compression driver
- 65° x 65° Constant Directivity waveguide
- Very high sensitivity (105 dB 1 W / 1 m)
- Power handling: 600 W continuous, 2400 W peak
- Lightweight trapezoidal polypropylene enclosure
- SuperSAM mounting system adjusts 60° V and 180° H

SB122

COMPACT 12" SUBWOOFER



- SB122 performance with enhanced weather-resistance
- Low-pass filter for parallel connection without added amp
- Large vent for enhanced LF output
- Cast-frame EVS12SB long-excursion woofer
- Power handling: 400 W continuous, 1600 W peak
- Parallel Neutrik Speakon high current input connectors
- Strong, composite trapezoidal enclosure
- Pole mount on top for pairing with ZX1
- Integral handle
- Available in black

| | Sx300 (all) | Sx600 (all) | SB122 |
|---|---|--|---|
| Frequency Range (-10 dB) | 50–20,000 Hz | 70–16,000 Hz | 43–200 Hz |
| Recommended High-Pass Frequency | — | 90 Hz | 40 Hz (12 dB/octave) |
| Axial Sensitivity, Biamp (SPL, 1 W @ 1 m) | 99 dB | 105 dB | 99 dB (half space) |
| Max. SPL @ 1 m (calc., full space) | Low Z: 131 dB 100V: 123 dB | 139 dB | 131 dB (half space) |
| Power Handling (Long-term, Short-term), Low Z | 300, 1200 W | 600, 2400 W | 400, 1600 W |
| Coverage (nominal -6 dB) H x V | 65° x 65° (Const. Dir. waveguide) | 65° x 65° (Const. Dir. waveguide) | Omnidirectional |
| Directivity Index (800–16,000 Hz) | 11.1 dB (+2.4/-4.1 dB) | 11.3 dB | — |
| LF Transducers | 12" DL12BFH | 12" DL12BFH (LF), 12" ND12A (MB) | 12" EVS12SB |
| HF Transducer | 1.25" DH3/2010A | 2" DH2T | — |
| Crossover Frequencies | 1,500 Hz | 1,800 Hz | 80–160 Hz |
| Nominal Impedance (non-transformer) | 8 Ω | 4 Ω | 8 Ω |
| Minimum Impedance (non-transformer) | 5.0 Ω | 3.5 Ω | 6.0 Ω |
| Input Connections | 2 four-pin Speakon | SJO cable/gland nut | 2 four-pin Speakon |
| Dimensions (H x W at front x D) | 23.07" x 16.89" x 12.28" (586 x 429 x 312 mm) | 45.79" x 16.89" x 12.28" (1163 x 429 x 312 mm) | 23.07" x 16.89" x 12.28" (586 x 429 x 312 mm) |
| Net Weight | 31.97 lb (14.5 kg) PIX: 39.0 lb (17.7 kg) | 80 lb (36.3 kg) | 33 lb (14.6 kg) |

LOUDSPEAKERS

CONCERT

INSTALL

PORTABLE PA

QRx



The QRx series has become the standard for regional sound companies, rental professionals and contractors who want compact high-performance loudspeakers with concert-grade EV components. Covered with rugged EVCoat, QRx looks great stacked, on poles, as monitors or flown with simple, integrated, L-track rigging points. Unique, fully-rotatable asymmetrical waveguides have a 15-degree downward bias to ensure high-frequency

coverage without the need to tilt the enclosure toward the audience. Our powerhouse DH7 large-format driver (3" voice-coil, 1.4" exit) provides the high-frequency engine, while a selection of DL and EVX woofers anchor the low and sub frequencies. The combination of high-level components, unique design and versatility make QRx series one of the best values in the industry.

QRx 112/75

12" TWO-WAY FULL-RANGE LOUDSPEAKER



- Compact with high output
- Ideal for mains (small-to-medium rooms) or monitors
- Cast-frame woofer, vented cabinet for extended LF
- 3" DH7 titanium HF compression driver
- Rotatable 75° x 50° Constant Directivity waveguide
- Asymmetric 10° down-angled coverage
- Externally switchable biamped or passive operation
- High sensitivity, 131 dB maximum SPL (peak)
- Power handling: 300 W continuous, 1200 W peak
- 5-sided 13-ply birch enclosure with monitor slant
- Built-in handles and L-Track rigging
- Black or white

QRx 115/75

15" TWO-WAY FULL-RANGE LOUDSPEAKER



- Compact with high output
- Ideal for mains (small-to-medium rooms) or monitors
- Cast-frame woofer, vented cabinet for extended LF
- 3" DH7 titanium HF compression driver
- Rotatable 75° x 50° Constant Directivity waveguide
- Asymmetric 10° down-angled coverage
- Externally switchable biamped or passive operation
- High sensitivity, 130 dB maximum SPL (peak)
- Power handling: 400 W continuous, 1600 W peak
- 5-sided 13-ply birch enclosure with monitor slant
- Built-in handles and L-Track rigging
- Black or white

QRx 118S

COMPACT 18" SUBWOOFER



- Concert-proven high-output performance
- Accurate transient detail
- EVX-180B woofer for superior linear excursion
- High sensitivity, 137 dB maximum SPL (peak)
- Power handling: 600 W continuous, 2400 W peak
- Rectangular 13-ply birch vented enclosure
- Built-in handles and 1 3/8" pole-mount receptacle
- Four threaded T-nuts for casters or dollies
- Black EVCoat finish

QRx 153/75**15" THREE-WAY FULL-RANGE LOUDSPEAKER**

- Compact with high-level, high-fidelity sound
- Cast-frame DL15ST woofer, vented box for extended LF
- Horn-loaded 8" MF8 midrange driver
- 3" DH7 titanium HF compression driver
- Asymmetric (10° down-angled) 75° H x 50° V coverage
- Biamped operation
- High sensitivity, 130 dB maximum SPL
- Power handling: 400 W continuous, 1600 W peak
- Trapezoidal (15°/side) 13-ply birch enclosure
- Built-in handles and L-Track rigging
- Black EVCoat finish

QRx 212/75**DUAL 12" TWO-WAY FULL-RANGE LOUDSPEAKER**

- Full-range performance with extra-full lows
- Ideal for mains in small-to-medium rooms
- Cast-frame woofer, vented cabinet for extended LF
- 3" DH7 titanium HF compression driver
- Rotatable 75° x 50° Constant Directivity waveguide
- Asymmetric 10° down-angled coverage
- Externally switchable biamped or passive operation
- High sensitivity, 135 dB maximum SPL (peak)
- Power handling: 600 W continuous, 2400 W peak
- Trapezoidal 13-ply birch enclosure
- Built-in handles and L-Track rigging
- Black or white

QRx 212H/75**DUAL 12" TWO-WAY FULL-RANGE LOUDSPEAKER**

- Full-range performance with extra-full lows
- Ideal for mains in small-to-medium rooms
- Cast-frame woofer, vented cabinet for extended LF
- 3" DH7 titanium HF compression driver
- Rotatable 75° x 50° Constant Directivity waveguide
- Asymmetric 10° down-angled coverage
- Externally switchable biamped or passive operation
- High sensitivity, 133 dB maximum SPL (peak)
- Power handling: 600 W continuous, 2400 W peak
- Trapezoidal 13-ply birch enclosure
- Built-in handles and L-Track rigging
- Black or white

QRx 218S**COMPACT DUAL 18" SUBWOOFER**

- High-level extended LF with concert-proven performance
- Accurate transient detail
- Available in Standard and Riggable (L-Track) versions
- EVX-180B woofers for superior linear excursion
- High sensitivity, 139 dB maximum SPL (peak)
- Power handling: 1200 W continuous, 4800 W peak
- Rectangular 13-ply birch vented enclosure
- Built-in handles and sealed pocket wheels (Standard)
- Integrated pole-mount receptacle (Standard)
- Black EVCoat finish

| | QRx 112/75 | QRx 115/75 | QRx 153/75 | QRx 212/75 | QRx 212H/75 | QRx 118S | QRx 218S |
|--|--|--|--|--|---|---|---|
| Frequency Response (-3 dB) | 75–15,000 Hz | 60–15,000 Hz | 50–16,000 Hz | 75 Hz – 16,000 Hz | 75 Hz – 15,000 Hz | 45–150 Hz | 38–125 Hz |
| Frequency Range (-10 dB) | 52–13,000 Hz | 45–16,000 Hz | 42–20,000 Hz | 52 Hz – 18,000 Hz | 52 Hz – 18,000 Hz | 30–250 Hz | 31–250 Hz |
| Recommended High-Pass Frequency | 45 Hz (12 dB/octave) | 45 Hz (12 dB/octave) | — | 45 Hz (12 dB/octave) | 45 Hz (12 dB/octave) | 36 Hz (12 dB/octave) | 35 Hz (12 dB/octave) |
| Axial Sensitivity (SPL, 1 W @ 1 m) (Biamp operation) | 98 dB Passive (100/112 dB) | 98 dB (98/110 dB) | 98/105 dB | 102 dB (102/112 dB) | 100 dB Passive (100/112 dB) | 98 dB | 102 dB |
| Max. SPL @ 1 m (calc.) | 131 dB | 130 dB | 130 dB | 135 dB | 133 dB | 137 dB ¹ | 139 dB |
| Power Handling (Continuous, Peak) | 350, 1400 W | 450, 1800 W | — | 600, 2400 W | 600, 2400 W | 600, 2400 W | 1200, 4800 W |
| Power Handling, Biamp: Continuous Peak | LF 300 W/HF 75 W LF 1200 W/HF 300 W | LF 400 W/HF 75 W LF 1,600 W/HF 300 W | LF 400 W/MB-HF 150 W LF 1600 W/MB-HF 600 W | LF 600 W/HF 75 W LF 2400 W/HF 300 W | LF 600 W/HF 75 W LF 2400 W/HF 300 W | — | — |
| Coverage (nominal -6 dB) H x V | 75° x 50° (up 15°, down 35°) | 75° x 50° (up 15°, down 35°) | 75° x 50° (up 15°, down 35°) | 75° x 50° (up 15°, down 35°) | 75° x 50° (up 15°, down 35°) | Omnidirectional | Omnidirectional |
| LF Transducer | 12" DL12BFH | 15" DL15X | 15" DL15ST | Two 12" DL12BFH | 12" DL12ST 12" DL12BFH | 18" EVX-180B | Two 18" EVX-180B |
| HF Transducer | 3" DH7 | 3" DH7 | MF: 8" MF8 HF: 3" DH7 | 3" DH7 | 3" DH7 | — | — |
| Crossover Frequencies (slope in Biamp mode) | 1,500 Hz (24 dB/octave) | 1,500 Hz (24 dB/octave) | 1,200 Hz | 1,500 Hz (24 dB/octave) | 1,200 Hz (24 dB/octave) | 100 Hz (24 dB/octave) | 100 Hz (24 dB/octave) |
| Nominal Impedance (Biamp mode) | 8 Ω (8 Ω/8 Ω) | 8 Ω (8 Ω/8 Ω) | — (8 Ω/12 Ω) | 4 Ω (4 Ω/8 Ω) | 6 Ω (6 Ω/8 Ω) | 8 Ω | 4 Ω |
| Input Connections | 2 Neutrik NL4 | 2 Neutrik NL4 | 2 Neutrik NL4 | 2 Neutrik NL4 | 2 Neutrik NL4 | 2 Neutrik NL4 | 2 Neutrik NL4 |
| Dimensions (H x W at front x D) | 26.6" x 15.35" x 14.6" (675 x 390 x 372 mm) | 29.9" x 17.7" x 16.02" (759 x 450 x 407 mm) | 48.8" x 18.4" x 19.09" (1,240 x 467 x 485 mm) | 38.98" x 15.47" x 14.77" (990 x 393 x 375 mm) | 15.5" x 39.0" x 14.9" (394 x 990 x 378 mm) | 35.5" x 17.7" x 23.6" (902 x 450 x 600 mm) | 39.96" x 22.05" x 23.7" (1,015 x 560 x 602 mm) |
| Net Weight | 57.3 lb (26.0 kg) | 71 lb (32.0 kg) | 103.6 lb (47 kg) | 80 lb (36.5 kg) | 84 lb (38 kg) | 105 lb (47.5 kg) | 150 lb (68 kg) |

¹ Half space



Tour X brings the engineering excellence and aesthetic design of EV's world-class tour systems to an innovative and exciting series of portable loudspeakers. Combining bold design and breakthrough performance, the Tour X series is optimized for applications, such as club sound, pro music and concert sound. The line's full-range loudspeakers and monitors utilize either 1.25" DH3/2010A or 2" ND2 compression drivers, protected by an advanced fourth-order crossover. Rotatable

Constant Directivity waveguides provide coverage-pattern flexibility while 12" or 15" SMX woofers deliver high power-handling with high sensitivity. Tour X 18" subwoofers, meanwhile, use high-excursion EVS-18S LF transducers to ensure plenty of impact with ultra-low distortion. For tour-class performance in a portable package that's surprisingly affordable, look no further than Tour X.

TX1122

12" TWO-WAY FULL-RANGE LOUDSPEAKER



- High-quality sound at high levels
- Excellent pattern control for short-to-medium throw
- Low-distortion SMX2120 woofer with fully symmetric drive
- 1.25" DH3/2010A titanium HF compression driver
- 90° H x 50° V Constant Directivity waveguide
- Advanced fourth-order crossover with HF protection
- 97 dB sensitivity, 130 dB maximum SPL
- Power handling: 500 W continuous, 2000 W peak
- Lightweight trapezoidal plywood/MDF enclosure
- Pole mount for use with subwoofer or stand
- Six 3/8" threaded suspension points
- Black EVCoat finish

TX1152

15" TWO-WAY FULL-RANGE LOUDSPEAKER



- High-output, high-quality sound
- Excellent pattern control for medium throw use
- Low-distortion SMX2151 woofer with fully symmetric drive
- 1.25" DH3/2010A titanium HF compression driver
- 60° x 40° rotatable Constant Directivity waveguide
- Advanced fourth-order crossover with HF protection
- 100 dB sensitivity, 133 dB maximum SPL
- Power handling: 500 W continuous, 2000 W peak
- Lightweight trapezoidal plywood/MDF enclosure
- Pole mount for use with subwoofer or stand
- Six 3/8" threaded suspension points
- Black EVCoat finish

TX2152

DUAL 15" TWO-WAY FULL-RANGE LOUDSPEAKER



- Very high SPL with smooth response
- Ideal as mains for small-to-medium clubs
- Excellent pattern control for medium throw use
- Dual SMX2151 woofers with fully symmetric drive
- 2" ND2 neodymium HF compression driver
- 60° x 40° rotatable Constant Directivity waveguide
- Advanced 6th-order crossover with HF protection
- 103 dB sensitivity, 139 dB maximum SPL
- Power handling: 1000 W continuous, 4000 W peak
- Internally braced trapezoidal plywood/MDF enclosure
- Six 3/8" threaded suspension points
- Black EVCoat finish

TX1181

18" SUBWOOFER



- High-power LF supplement to TX1122 and TX1152
- High-excursion EVS-18S woofer
- 6 dB/octave low-pass filter for parallel connection without added amp
- 100 dB sensitivity, 132 dB maximum SPL
- Power handling: 500 W continuous, 2000 W peak
- Top-side socket for speaker pole
- Six mount points for optional wheel kit
- Braced plywood/MDF enclosure
- Black EVCoat finish

TX2181

DUAL 18" SUBWOOFER



- High-power LF supplement to TX2152
- Low-distortion port design
- Two high-excursion EVS-18S woofers
- Use with processor and dedicated amp channel
- 103 dB sensitivity, 138 dB maximum SPL
- Power handling: 1000 W continuous, 4000 W peak
- Six mount points for optional wheel kit
- Braced plywood/MDF enclosure
- Black EVCoat finish

See page 31 for Tour X Floor Monitors.

| | TX1122 | TX1152 | TX2152 | TX1181 | TX2181 |
|--|--|--|---|--|---|
| Speaker Type | Full-range | Full-range | Full-range | Subwoofer | Subwoofer |
| Frequency Response (-3 dB) | 60–20,000 Hz | 55–20,000 Hz | 55–13,000 Hz | 50–160 Hz | 50–160 Hz |
| Frequency Range (-10 dB) | 45–20,000 Hz | 40–20,000 Hz | 50–18,000 Hz | 45–700 Hz | 40–1,500 Hz |
| Sensitivity (SPL, 1 W/1 m) | 97 dB | 100 dB | 103 dB | 100 dB | 103 dB |
| Max. SPL/1m (calc) | 130 dB | 133 dB | 139 dB | 132 dB | 138 dB |
| System Power Handling (Continuous, Peak) | 500, 2000 W | 500, 2000 W | 1000, 4000 W | 500, 2000 W | 1000, 4000 W |
| Coverage(Nominal -6 dB) | 90° H x 50° V | 60° x 40° rotatable | 60° x 40° rotatable | — | — |
| LF Transducer | 12" SMX2120 | 15" SMX2151 | Two 15" SMX2151 | 18" EVS-18S | Two 18" EVS-18S |
| HF Transducer | 1.25" DH3/2010A | 1.25" DH3/2010A | 2" ND2 | — | — |
| Internal Crossover | Yes | Yes | Yes | Low-pass filter | No |
| Crossover Frequency | 1,750 Hz | 1,650 Hz | 1,750 Hz | — | — |
| Nominal Impedance (Passive) | 8 Ω | 8 Ω | 4 Ω | 8 Ω | 4 Ω |
| Minimum Impedance | 5.4 Ω | 5.6 Ω | 3.1 Ω | 7.5 Ω | 2.9 Ω |
| Input Connections | Parallel Neutrik NL4 | Parallel Neutrik NL4 | Parallel Neutrik NL4 | Parallel Neutrik NL4 | Parallel Neutrik NL4 |
| Enclosure Material | Plywood and MDF with EVCoat | Plywood and MDF with EVCoat | Plywood and MDF with EVCoat | Plywood and MDF with EVCoat | Plywood and MDF with EVCoat |
| Flying Suspension | Six 3/8" threaded inserts | Six 3/8" threaded inserts | Six 3/8" threaded inserts | — | — |
| Dimensions (H x W x D) | 24.25" x 15.04" x 14.96" (616 x 382 x 380 mm) | 30.55" x 17.56" x 17.56" (776 x 446 x 446 mm) | 45.43" x 20" x 18.54" in (1154 x 508 x 471 mm) | 30.28" x 17.28" x 23.27" (769 x 439 x 591 mm) | 45.43" x 20" x 27.2" (1154 x 508 x 691 mm) |
| Net Weight | 44.53 lb (20.2 kg) | 61.29 lb (27.8 kg) | 94.36 lb (42.8 kg) | 74.52 lb (33.8 kg) | 123.68 lb (56.1 kg) |



Clear, powerful and musical, the Live X series was born to command the stage for professional music performance. Available in both powered and passive versions, Live X loudspeakers offer top-quality components in remarkably affordable configurations that put the EV-quality experience within reach for artists, engineers and live-sound businesses. Designed for a wide range of portable sound applications, Live X loudspeakers are housed in

hardy stackable enclosures of solid wood, making them lighter than comparable-quality composite or plastic boxes and therefore easier to load, transport and set up. With high output, extended frequency range and high sensitivity, Live X loudspeakers are clean, flat and hot, making music of all kinds sound its best. The Live X series is serious gear for serious sound.

ELX112 12" TWO-WAY FULL-RANGE



- Compact power for sound reinforcement and stage monitoring
- EVS-12K woofer
- 1.5" DH-1K titanium HF compression driver
- 55 Hz – 20 kHz frequency range
- 90° x 50° coverage-pattern waveguide
- 60° monitor angle
- 132 dB maximum SPL
- Power handling: 250 W continuous, 1000 W peak
- Braced 15 mm plywood enclosure
- Pole mount or stack with Live X subwoofers
- Black textured finish

ELX112P POWERED 12" TWO-WAY FULL-RANGE



- ELX112 performance with self-amplification
- 50 Hz – 20 kHz frequency range
- Lightweight, cool-running 1000 W Class D amp
- Biamped with 24 dB/octave crossover
- Transducer protection
- Bypassable high-pass for external subwoofer
- XLR, TRS and RCA connections
- Versatile gain, mixing and processing controls
- Pre- or post-mix parallel outputs

ELX115 15" TWO-WAY FULL-RANGE



- More power, fuller sound for larger rooms
- EVS-15K woofer
- 1.5" DH-1K titanium HF compression driver
- 50 Hz – 20 kHz frequency range
- 90° x 50° coverage-pattern waveguide
- 60° monitor angle
- 134 dB maximum SPL
- Power handling: 400 W continuous, 1600 W peak
- Braced 15 mm plywood enclosure
- Pole mount or stack with Live X subwoofers
- Black textured finish

ELX115P POWERED 15" TWO-WAY FULL-RANGE



- ELX115 performance with self-amplification
- 44 Hz – 20 kHz frequency range
- Lightweight, cool-running 1000 W Class D amp
- Biamped with 24 dB/octave crossover
- Transducer protection
- Bypassable high-pass for external subwoofer
- XLR, TRS and RCA input connections
- Versatile gain, mixing and processing controls
- Pre- or post-mix parallel outputs

ELX118 18" SUBWOOFER



- Supplemental bass for ELX112 or ELX115
- EVS-18K woofer for extended LF
- 35 Hz – 200 Hz frequency range
- 134 dB maximum SPL
- Power handling: 400 W continuous, 1600 W peak
- Braced 15 mm plywood enclosure
- Stack or pole-mount full-range boxes
- Black textured finish

ELX118P POWERED 18" SUBWOOFER



- ELX118 performance with self-amplification
- EVS-18K woofer for extended LF
- 32 Hz – 130 Hz frequency range
- Lightweight, cool-running 700 W Class D amp
- Selectable normal/boost modes
- XLR and TRS combo input
- XLR parallel output

**ELX215****DUAL 15" TWO-WAY FULL-RANGE**

- High-volume punch and ultra-wide frequency response
- Ideal for mains
- Two EVS-15K woofers for extended LF
- 1.5" DH-1K titanium HF compression driver
- 38 Hz – 20 kHz frequency range
- 90° x 50° coverage-pattern waveguide
- 137 dB maximum SPL
- Power handling: 600 W continuous, 2400 W peak
- Braced 15 mm plywood enclosure
- Black textured finish

See page 50 for Live X Covers.

| | ELX112 | ELX112P | ELX115 | ELX115P | ELX118 | ELX118P | ELX215 |
|---|---|---|--|--|---|---|---|
| Speaker Type | Full-range, two-way, wedges | Full-range, two-way, wedges | Full-range, mid-high, two-way | Full-range, mid-high, two-way | Subwoofer | Subwoofer | Full-range, mid-high, two-way |
| Frequency Response (-3 dB) | 82 – 18,000 Hz | 60 – 18,000 Hz | 75 – 18,000 Hz | 56 – 18,000 Hz | 50 – 100 Hz | 42 – 100 Hz | 62–18,000 Hz |
| Frequency Range (-10 dB) | 55 – 20,000 Hz | 50 – 20,000 Hz | 50 – 20,000 Hz | 44 – 20,000 Hz | 35 – 200 Hz | 32 – 130 Hz | 38 – 20,000 Hz |
| Axial Sensitivity (SPL, 1 W/1 m) | 94 dB | — | 95 dB | — | 100 dB | — | 96 dB |
| Max. SPL/1m (calc) | 132 dB Half Space | 132 dB | 134 dB Half Space | 134 dB | 134 dB | 134 dB | 137 dB |
| Recommended High-pass Frequency | 45 Hz | — | 40 Hz | — | 30 Hz | — | 35 Hz |
| System Power Handling (Continuous, Program, Peak) | 250 W Continuous 1000 W Peak | — | 400 W Continuous 1600 W Peak | — | 400 W Continuous 1600 W Peak | — | 600 W Continuous 2400 W Peak |
| Coverage (Nominal -6 dB) H x V | 90° x 50° | 90° x 50° | 90° x 50° | 90° x 50° | Omnidirectional | Omnidirectional | 90° x 50° |
| Power Rating | — | 1000 W | — | 1000 W | — | 700 W | — |
| LF Transducer | 12" EVS-12K woofer | 12" EVS-12K woofer | 15" EVS-15K woofer | 15" EVS-15K woofer | 18" EVS-18K woofer | 18" EVS-18K woofer | 15" EVS-15K woofer |
| HF Transducer | DH-1K | DH-1K | DH-1K | DH-1K | — | — | DH-1K |
| Internal Crossover | Yes | Yes | Yes | Yes | Yes | Yes | Yes |
| Nominal Impedance (Passive) | 8 Ω | 8 Ω | 8 Ω | 8 Ω | 8 Ω | 8 Ω | 4 Ω |
| Input Connections | Parallel Neutrik NL4 | Parallel Neutrik NL4 | Parallel Neutrik NL4 | Parallel Neutrik NL4 | Parallel Neutrik NL4 | Parallel Neutrik NL4 | Parallel Neutrik NL4 |
| Woofer Size | 12" (304.8 mm) | 12" (304.8 mm) | 15" (381 mm) | 15" (381 mm) | 18" (457.2 mm) | 18" (457.2 mm) | 15" (381 mm) |
| Dimensions (H x W x D) | 23.9" x 14.25" x 13.39" (607 x 362 x 340 mm) | 23.9" x 14.25" x 13.39" (607 x 362 x 340 mm) | 27.87" x 17.01" x 15.04" (708 x 432 x 382 mm) | 27.87" x 17.01" x 15.04" (708 x 432 x 382 mm) | 26.02" x 19.96" x 22.6" (661 x 507 x 574 mm) | 26.02" x 19.96" x 22.6" (661 x 507 x 574 mm) | 45.43" x 17.01" x 19.72" (1154 x 432 x 501 mm) |
| Net Weight | 35.27 lb (16.0 kg) | 37.04 lb (16.8 kg) | 48.28 lb (21.9 kg) | 49.6 lb (22.5 kg) | 67.46 lb (30.6 kg) | 69 lb (31.3 kg) | 89.73 lb (40.7 kg) |



ZLX

Electro-Voice condenses decades of proven pro audio engineering know-how into ZLX, its next generation of high-performance portable loudspeakers. Available in powered and passive 12" and 15" two-way versions, ZLX was designed with a singular goal: to deliver best-in-class performance across every detail. No other comparably priced loudspeaker sounds better or gives you more control over your sound. ZLX powered models match the legendary

quality of EV-engineered drivers with a custom-built 1000 W Class-D amplifier module and feature an LCD display and innovative single-knob DSP control with presets so you can quickly optimize loudspeaker performance according to your performance style and space. Whether used as mains or monitors, ZLX will enhance your gig with incredible sonic impact and intelligibility – the renowned "EV Sound" the pros trust.

ZLX-12P

12" TWO-WAY POWERED LOUDSPEAKER



- Compact and lightweight
- Standout choice for sound reinforcement or stage-monitoring
- 12" woofer for low-end punch in a compact enclosure
- LCD display and one-knob DSP control with presets for precise, speedy set up
- Input level meters and independent amplifier control to ensure optimal gain structure
- Front LED for "power on" and "limit" indication
- 1.5" high-frequency titanium compression driver
- Durable composite construction with innovative hi/lo grip design for easy pole mounting
- Patented split-baffle design for superior drive time alignment
- 1000 W Class-D amplifier
- 126 dB maximum SPL
- 50 Hz – 20 kHz frequency range

ZLX-15P

15" TWO-WAY POWERED LOUDSPEAKER



- Crisp clean highs and tight, deep lows for larger spaces
- 15" woofer for extended low frequency response
- LCD display and one-knob DSP control with presets for precise, speedy set up
- Input level meters and independent amplifier control to ensure optimal gain structure
- Front LED for "power on" and "limit" indication
- 1.5" high-frequency titanium compression driver
- Durable composite construction with innovative hi/lo grip design for easy pole mounting
- Patented split-baffle design for superior drive time alignment
- 1000 W Class-D amplifier
- 127 dB maximum SPL
- 42 Hz – 20 kHz frequency range

LCD DISPLAY AND SINGLE-KNOB DSP CONTROL

VISUAL CONTROL AND MONITORING WITH PRESETS

In the case of the ZLX's uncluttered control panel, less really does mean more. Though the multiple dials and switches on other powered loudspeakers may suggest more functionality, ZLX's powerful DSP engine is accessed by a clean single-knob design with LCD display, and actually offers the most precise control and configuration available at its price point. Use the presets to optimize ZLX according to your application (music, live, speech, club) and your location (pole mount, monitor, install) and hear the difference in seconds. Smart design, straightforward operation.



ZLX-12**12" TWO-WAY PASSIVE LOUDSPEAKER**

- 12" woofer for low-end punch in a compact enclosure
- 1.5" high-frequency titanium compression driver
- Durable composite construction with innovative hi/lo grip design for easy pole mounting
- Patented split-baffle design for superior drive time alignment
- 55 Hz – 20 kHz frequency range
- 250 W continuous and 1000 W peak power handling
- 95 dB SPL sensitivity; 125 dB maximum SPL

ZLX-15**15" TWO-WAY PASSIVE LOUDSPEAKER**

- 15" woofer for extended low frequency response
- 1.5" high-frequency titanium compression driver
- Durable composite construction with innovative hi/lo grip design for easy pole mounting
- Patented split-baffle design for superior drive time alignment
- 44 Hz – 20 kHz frequency range
- 250 W continuous and 1000 W peak power handling
- 96 dB SPL sensitivity; 126 dB maximum SPL



See page 50 for ZLX Covers.

| | ZLX-12P | ZLX-15P | ZLX-12 | ZLX-15 |
|-----------------------------------|--|---|---|---|
| Speaker Type | Two-way, powered | Two-way, powered | Two-way, passive | Two-way, passive |
| Frequency Response | 65 Hz – 18 kHz ¹ | 55 Hz – 18 kHz ¹ | 82 Hz – 18 kHz ² | 56 Hz – 18 kHz ² |
| Frequency Range | 50 Hz – 20 kHz ¹ | 42 Hz – 20 kHz ¹ | 55 Hz – 20 kHz | 44 Hz – 20 kHz |
| Axial Sensitivity | — | — | 95 dB | 96 dB |
| Max. Measured SPL | 126 dB | 127 dB | 125 dB | 126 dB |
| Recommended High-pass Frequency | — | — | 40 Hz | 40 Hz |
| Power Handling (Continuous, Peak) | — | — | 250 W Continuous 1000 W Peak | 250 W Continuous 1000 W Peak |
| Coverage (H x V) | 90° x 60° | 90° x 60° | 90° x 60° | 90° x 60° |
| Power Rating | 1000 W | 1000 W | — | — |
| LF Transducer | 12" EVS-12K woofer | 15" EVS-15L woofer | 12" EVS-12K woofer | 15" EVS-15L woofer |
| HF Transducer | DH-1K | DH-1K | DH-1K | DH-1K |
| Crossover Frequency | — | — | 2.1 kHz | 1.7 kHz |
| Nominal Impedance | — | — | 8 Ω | 8 Ω |
| Minimum Impedance | — | — | 7 Ω | 7 Ω |
| Connectors | Two XLR/TRS Combo Jack, one 3.5 mm Input and one XLR link Output | | Dual NL4 | Dual NL4 |
| Enclosure Material | Polypropylene | Polypropylene | Polypropylene | Polypropylene |
| Grille | 18 ga steel with black powder coat | 18 ga steel with black powder coat | 18 ga steel with black powder coat | 18 ga steel with black powder coat |
| Dimensions (H x W x D) | 24" x 14" x 14" (610 x 356 x 356 mm) | 27" x 17" x 15" (685 x 423 x 383 mm) | 24" x 14" x 14" (610 x 356 x 356 mm) | 27" x 17" x 15" (685 x 423 x 383 mm) |
| Net Weight | 34.3 lb (15.6 kg) | 38.0 lb (17.3 kg) | 32.8 lb (14.9 kg) | 36.5 lb (16.6 kg) |

¹ Using MUSIC DSP preset.

² Full Space Measurement, will have low frequency extension when mount on floor or wall.

RIGGING AND ACCESSORIES

XLC215 and XLD B-1 GRID + XLC215 + AGCD + XLD LOUDSPEAKER

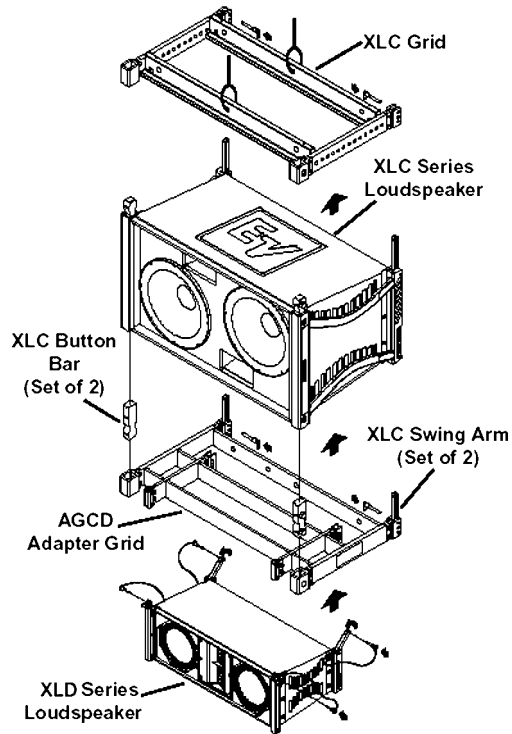

XLD281 XLD281 + CBEAM

XLD281 XLD281 + DOLLY

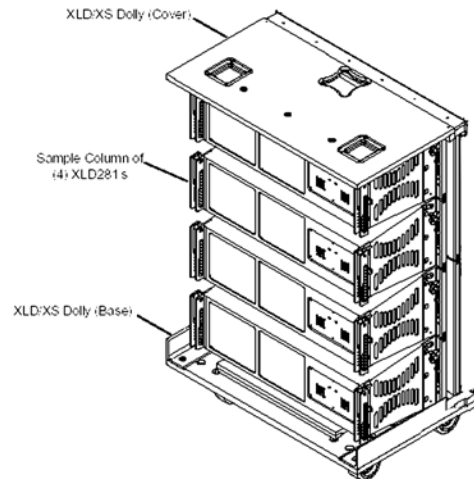
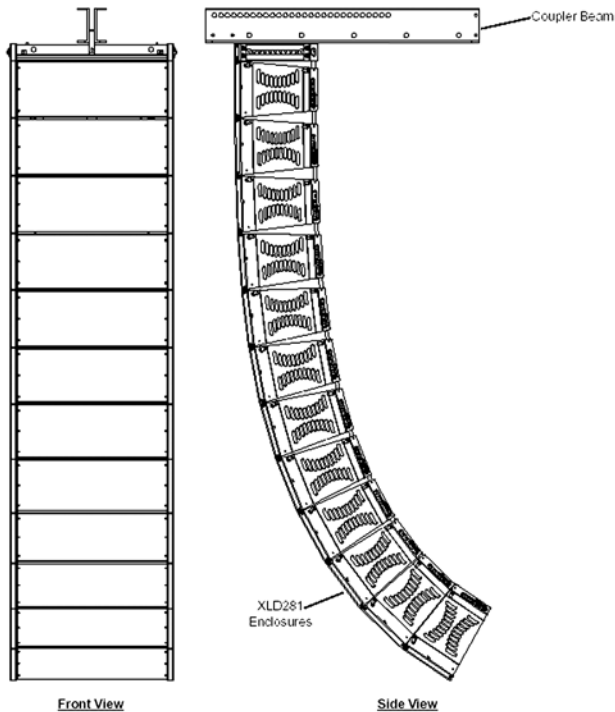

(One half of dolly shown in drawing)

LOUDSPEAKERS
CONCERT
INSTALL
PORTABLE PA

XLC CONCERT/PORTABLE RIGGING

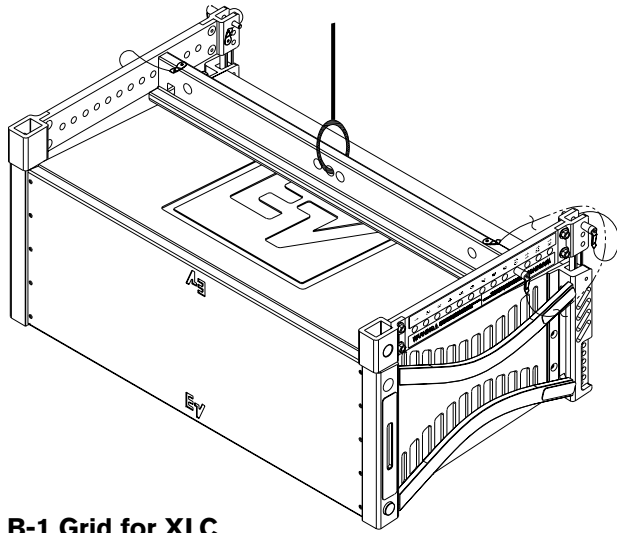

B-1 Grid for XLC
(other rigging hardware included with speaker)

XLCi INSTALL RIGGING

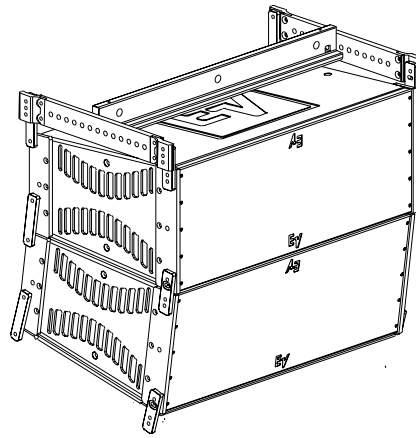

B-2 Grid for XLCi
(other rigging hardware included with speaker)

XLC and XLVC GROUND STACK KITS

XGS-3

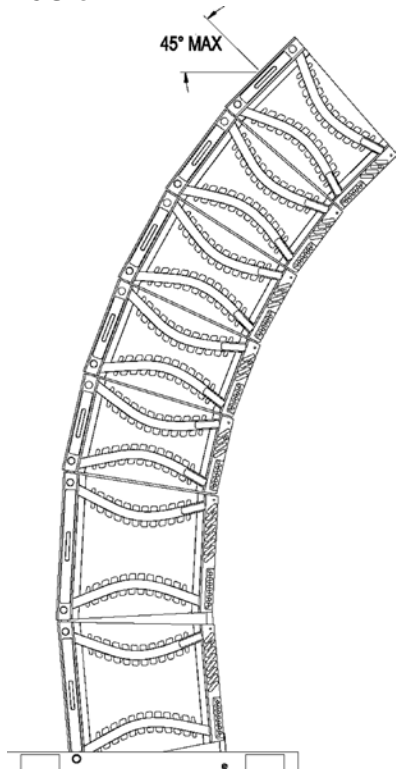

XGS-4

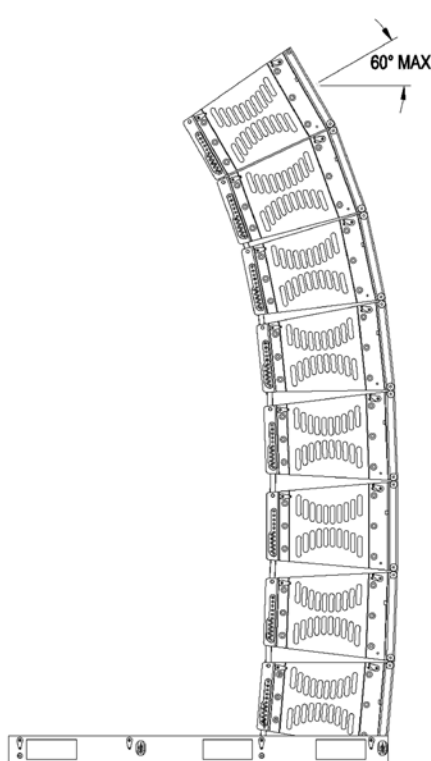

Xi-1082 UNDER BALCONY/ON-WALL MOUNT

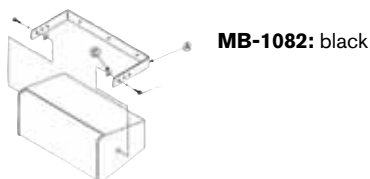

MB-1082: black

FRi-2082 UNDER BALCONY/ON-WALL MOUNT

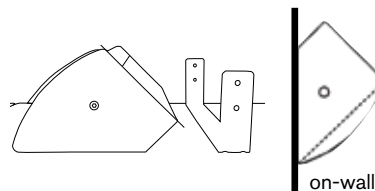

on-wall

The 100° x 100° dispersion angle allows the FRi-2082 to be installed vertically on the wall as well. Mounting bracket comes with FRi-2082.

LOUDSPEAKERS

CONCERT

INSTALL

PORTABLE PA

EV INNOVATION

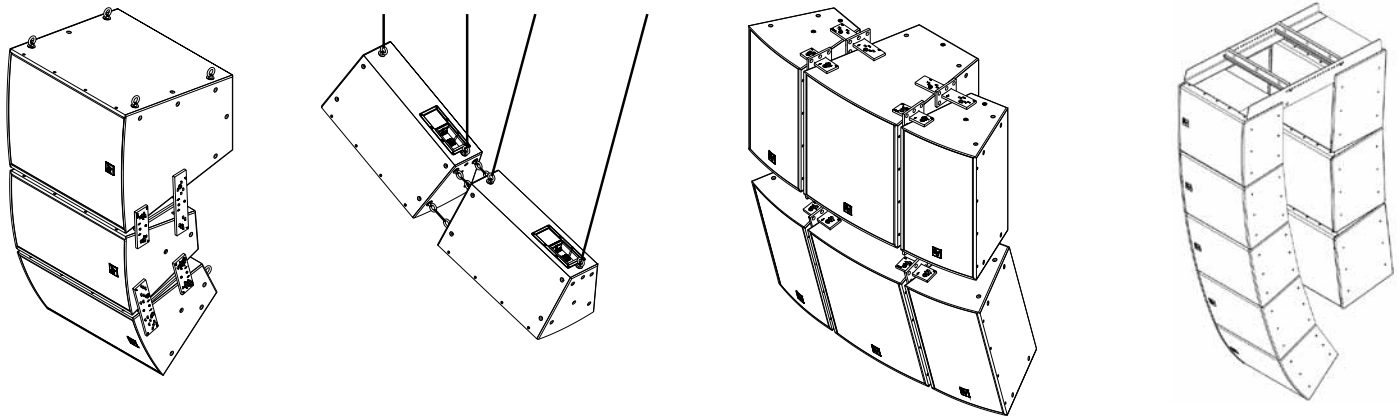

EVF and EVH Series

HRK AND VRK RIGGING KITS

(HRK not shown)

VRK-1

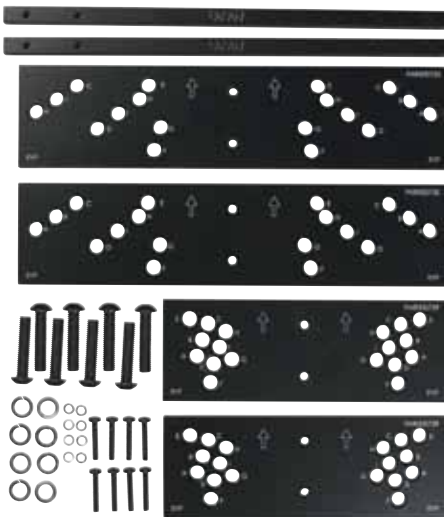

VRK-2

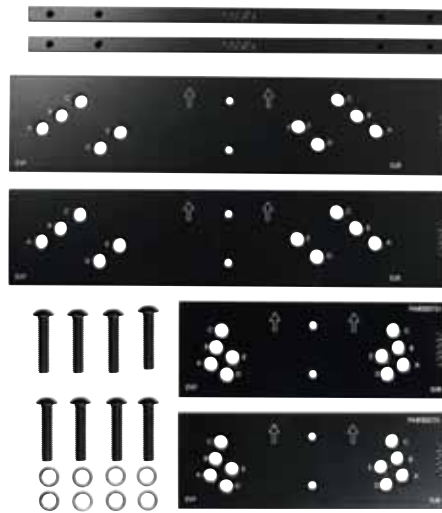

EVA, EVF AND EVH

GLAND NUT COVER PLATES



CDG

Dual gland nut cover plate



CDNL4

Dual NL4 cover plate



CSG

Single gland nut cover plate

EVA Rigging

EVA modules connect with an integrated internal top-to-bottom metal structure. Hidden by cover panels, this nearly invisible rigging system gives an EVA cluster the aesthetic appeal of an architectural element rather than a loudspeaker system. The rigging system is designed to carry an array with a safety factor of greater than 8:1.



EVA-SG2 (Standard Grid)

For typical tilt angles in 3 and 4 module arrays and pull-up applications in large arrays when extreme angles are required. Includes one spreader bar.



EVA-EG2 (Extended Grid)

For typical tilt angles in arrays taller than four modules, or extreme angles in arrays of four modules or less. Includes one spreader bar.

EVA-CG (Coupler Grid, not shown)

Connects full-range modules and single 15" subwoofers so that you can fly the subs without increasing trim height.

EV INNOVATION ACCESSORIES

EVI-AC

ACCESS CARD



EV-Innovation Access Card lets you test EVA, EVF or EVH transducers and protection circuitry without disassembling the cabinet.

EVU-TK60

TRANSFORMER KIT



60-Watt, 70.7/100-Volt input transformer for EVU systems, with multiple taps.

TK-150

TRANSFORMER KIT



70/100 V transformer kit for EVF and EVH.

EVU-CDNL4

COVER PLATE KIT



Dual NL4 cover plate for EVU series only.

EVI

EVI Series

EBK-1 (EYEBOLT KIT)

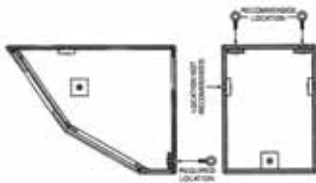

Contains three 3/8-16 forged shoulder bolts.

EVI-12

"U" STYLE BRACKET

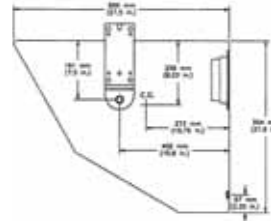

EVI-12MBB: black
EVI-12MBW: white

EVI-15

"U" STYLE BRACKET

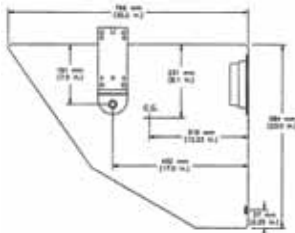

EVI-15MBB: black
EVI-15MBW: white

EVI-28

"U" STYLE BRACKET

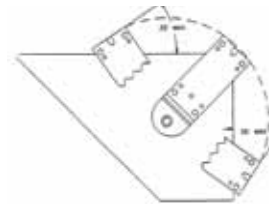

EVI-28MBB: black
EVI-28MBW: white

The radius of action is 140°.

EVID

EVID 3.2, EVID 4.2 or EVID 6.2 + AB-ZE



S-40

WALL, CEILING OR STAND MOUNT

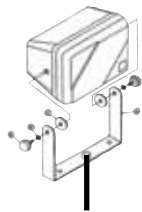

Note: The thread diameter can be reduced with a standard 5/8" screw adapter for different mic stands.

S-40 MB/B: black
S-40 MB/W: white

LOUDSPEAKERS

CONCERT

INSTALL

PORTABLE PA

Sx300 and SB122

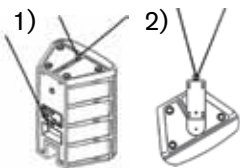

- 1) MB 100
- 2) MB 100 + MB 200

Security advice:
 When flown by 90° (figure 2), do not use eyebolts only!

Sx300
 MB 300 B Array-kit (2 plates) black

SB122
 MB 300 W Array-kit (2 plates) white

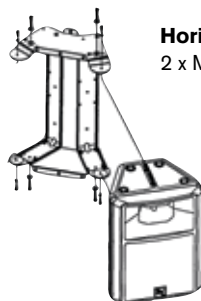

Horizontal Cluster 120° (2 systems)
 2 x MB 200 + 1 x MB 300 necessary

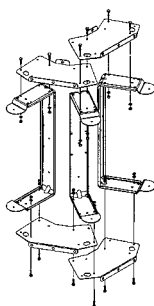

Horizontal Cluster 180° (3 systems)
 3 x MB 200 + 2 x MB 300 necessary



Wall or Ceiling-Mount
 1 x MB 200 necessary

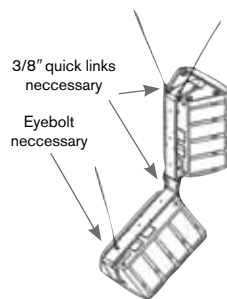

Vertical Cluster
 2 x MB 200 necessary

Live X, ZLX and ZXA1 Covers



Each cover is custom fit with access to the speaker handles.

ZX1

ZX1 + TCA-ZX1

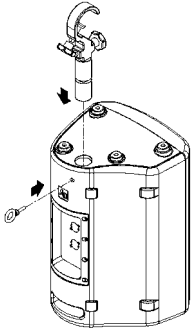

ZX1i + AB-ZE

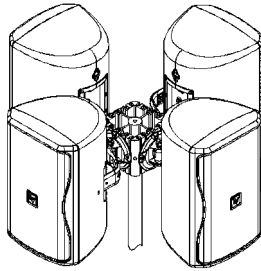

ZX1 + MP1-B

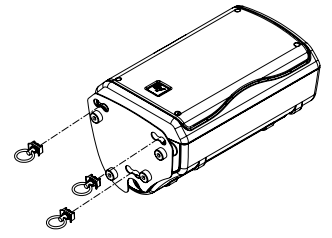

ZX3 and ZX5

MB3 or MB5 WALL/CEILING MOUNT BRACKET



CB5

CLUSTER BRACKET KIT

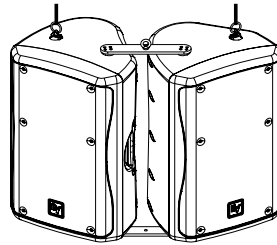

VSA-1

VERTICAL STRONG-ARM MOUNT

VSA-1 using TSA-1



EBK-3

FORGED M8 EYEBOLT KIT



SSK-1

SINGLE-STUD RIGGING KIT



HA-3 or HA-5

HANDLE MOUNT ADAPTER

Handle adapter to be used with VSA-1



LOUDSPEAKERS

CONCERT

INSTALL

PORTABLE PA

Tour Grade



Designed for the most demanding applications in both touring and installed sound, EV's ultra-reliable Tour Grade amplifiers offer a unique combination of output power, sonic excellence and high efficiency, all in a compact, lightweight format that's ideal for life on the road. Based on grounded-bridge Class-H topology, Tour Grade amps feature an integrated switch-mode power supply for maximum power per pound, with plenty of headroom to

handle transient peaks and low loads. The optional RCM-26 remote control module adds state-of-the-art IRIS-Net-controlled DSP, including FIR-Drive loudspeaker optimization, IIR filters, signal routing, level control, dynamics and system supervision. The optional RCM-28 module provides additional DSP options as well as the revolutionary OMNEO Media Networking Architecture for the most demanding applications.

TG5 2000 W PER CHANNEL POWER AMPLIFIER



- High-level touring performance
- Rugged, lightweight package
- 2000 W per channel (2 Ω)
- Grounded-bridge Class-H design
- Switch-mode power supply
- Microprocessor-controlled
- Front LCD panel for operation-mode setup and monitoring
- Slot for optional RCM-26 or RCM-28 IRIS-Net-compatible DSP and control module
- 11-level protection package
- Only 31.4 lb (14.2 kg)

TG7 3500 W PER CHANNEL POWER AMPLIFIER



- High-power performance for top-level tours
- Rugged, lightweight package
- 3500 W per channel (2 Ω)
- Grounded-bridge Class-H design
- Switch-mode power supply
- Microprocessor-controlled
- Front LCD panel for operation-mode setup and monitoring
- Slot for optional RCM-26 or RCM-28 IRIS-Net-compatible DSP and control module
- 11-level protection package
- Only 32 lb (14.5 kg)

UCC1 REMOTE CONTROL INTERFACE FOR IRIS-NET



- USB-CAN converter for IRIS-Net enabled devices
- Supports up to 100 CAN devices
- Parallel CAN connections on RJ-45 Ethercons
- USB-powered
- XLR jack for audio bus monitoring
- 19" rackmount panel included
- Status LED shows CAN activity and device status

RCM-26

IRIS-NET REMOTE CONTROL MODULE FOR TOUR GRADE AMPLIFIERS



- Extend Tour Grade performance with powerful DSP functionality
- Advanced FIR-Drive loudspeaker optimization
- High precision load impedance supervision
- Two GPI and two GPO ports
- One-button system test for fast, complete check of connected cables and components
- Pilot tone detection for cable supervision
- Six recallable DSP/configuration presets
- Parallel RJ-45 CAN bus connectors

RCM-28

IRIS-NET REMOTE CONTROL MODULE FOR TOUR GRADE AMPLIFIERS



- OMNEO Media Networking Architecture
- Advanced FIR-Drive loudspeaker optimization
- High precision load impedance supervision
- Two GPI and two GPO ports
- One-button system test for fast, complete check of connected cables and components
- Pilot tone detection for cable supervision
- Dedicated Array EQ and Delay DSP
- Recallable DSP/configuration presets

| | TG5 | | | TG7 | | | RCM-26 | RCM-28 |
|--|---|--------|--------|---|--------|--------|--|---|
| Topology | Class-H grounded bridge | | | Class-H grounded bridge | | | — | — |
| Impedance | 2 Ω | 4 Ω | 8 Ω | 2 Ω | 4 Ω | 8 Ω | — | — |
| Continuous Output/Channel (1 kHz, THD 1%) | 2000 W | 1450 W | 850 W | 3500 W | 2500 W | 1500 W | — | — |
| Continuous Output/Channel (20–20,000 Hz, THD < 0.2%) | — | 1200 W | 600 W | — | 2100 W | 1050 W | — | — |
| Maximum Bridged Output: 4, 8 Ω | — | 3800 W | 2900 W | — | 7000 W | 5000 W | — | — |
| Amplifier Gain (Selectable) | 39, 35 or 32 dB | | | 41.5, 35 or 32 dB | | | — | — |
| Signal-to-Noise Ratio (A-weighted) | 109 dB | | | 111 dB | | | 116 dB | 120 dB |
| Total Harmonic Distortion | 0.05% | | | 0.05% | | | <0.005% (THD+Noise) | <0.002% (THD+Noise) |
| Intermodulation Distortion (SMPTE) | 0.05% | | | 0.05% | | | — | — |
| DIM 30 | 0.02% | | | 0.02% | | | — | — |
| Slew Rate | 30 V/μs | | | 35 V/μs | | | — | — |
| Analog Inputs | Yes | | | Yes | | | 2 audio inputs on internal slot connector, pre-/post-fader selectable | |
| Input Impedance (Balanced) | 20 kΩ | | | 20 kΩ | | | — | — |
| Input Sensitivity (Selectable) | 0, +6, +7 dBu | | | 0, +6, +9 dBu | | | — | — |
| Digital Inputs | Optional (RCM-26 / RCM-28) | | | Optional (RCM-26 / RCM-28) | | | AES3 (AES/EBU) format, XLR In/Thru connectors | |
| A/D Conversion | See RCM-26 / RCM-28 | | | See RCM-26 / RCM-28 | | | 24 Bit linear, Sigma-Delta, 128x oversampling | |
| D/A Conversion | See RCM-26 / RCM-28 | | | See RCM-26 / RCM-28 | | | 24 Bit linear, Sigma-Delta, 128x oversampling | |
| Data Format | See RCM-26 / RCM-28 | | | See RCM-26 / RCM-28 | | | 24 Bit linear A/D and D/A conversion, 48 Bit processing | |
| Internal Processing | See RCM-26 / RCM-28 | | | See RCM-26 / RCM-28 | | | 2 DSPs (150 MHz, 300 MIPS) | Dual Core DSP, 500 MIPS |
| Sample Rate | See RCM-26 / RCM-28 | | | See RCM-26 / RCM-28 | | | 48 kHz | 48 kHz |
| Sample Rate Conversion (SRC) | See RCM-26 / RCM-28 | | | See RCM-26 / RCM-28 | | | 32 kHz – 192 kHz internal sample rate converter | |
| Network Control (IRIS-Net) | Optional (RCM-26 / RCM-28) | | | Optional (RCM-26 / RCM-28) | | | Yes | IRIS-Net control/OMNEO |
| Control Protocol | See RCM-26 / RCM-28 | | | See RCM-26 / RCM-28 | | | CAN Bus | OMNEO/OCA |
| CAN Bus Interface | See RCM-26 / RCM-28 | | | See RCM-26 / RCM-28 | | | 10–500 kbaud, 2x RJ-45 (IRIS-Net Control) | Not required because of OCA support |
| GPIO Control Port | See RCM-26 / RCM-28 | | | See RCM-26 / RCM-28 | | | 1 x 6-pole Euroblock, 2 control inputs, 2 control outputs, (+5 V, 200 mA /GND) | |
| FIR-Drive | Optional (RCM-26 / RCM-28) | | | Optional (RCM-26 / RCM-28) | | | Yes | Yes |
| Power Supply | 100–240 V, 50–60 Hz | | | 100–240 V, 50–60 Hz | | | — | — |
| Power Consumption 1/8 max. output @ 4 Ω | 1000 W | | | 1450 W | | | — | — |
| Dimensions (H x W x D) | 3.47" x 19" x 20.16" (88.1 x 482.6 x 512 mm) | | | 3.47" x 19" x 20.16" (88.1 x 482.6 x 512 mm) | | | 3.33" x 3.17" x 9.06" (84.7 x 80.4 x 230.3 mm) | 3.33" x 3.17" x 9.06" (84.7 x 80.4 x 230.3 mm) |
| Net Weight | 31.4 lb (14.2 kg) | | | 32 lb (14.5 kg) | | | 0.53 lb (240 g) | 0.53 lb (240 g) |

Remote Control



Built for the toughest tours and high-profile installations, Precision series remote control amplifiers deliver superb concert sound in a rugged package that stands up to the rigors of the road. High-power Class-AB designs drive your boxes as hard as you need to get full, clear coverage. Ultra-low distortion keeps your sound clean even at peak volumes with heavy loads. And road-ready design features—dual power supplies, multiple fans and complete electronic protection circuitry—keep the show going while

safeguarding both your investment and your reputation. Long a staple of top touring companies, Precision series amplifiers are better than ever with the inclusion of the RCM-24 module, which brings Precision series amps under IRIS-Net control with state-of-the-art DSP technology. Offering system supervision, signal routing, IIR filters, level control and dynamics, Precision series remote control amplifiers set the standard for professional concert sound.

P1200RL

850 W PER CHANNEL REMOTE CONTROL AMPLIFIER



- Performance and control for tours and installation
- 850 W per channel (2 Ω)
- Class-AB design
- IRIS-Net enabled for remote control, monitoring and DSP processing via included RCM-24 module
- Eight recallable DSP/configuration presets
- System check button for fast, complete test of all connected cables and loudspeaker components
- Two GPI and two GPO ports
- Parallel RJ-45 CAN bus connectors
- Pilot tone detection for cable supervision

P1200RT

590 W PER CHANNEL REMOTE CONTROL AMPLIFIER



- Performance and control for fixed installation
- 590 W per channel into 70/100 V line
- Class-AB design
- IRIS-Net enabled for remote control, monitoring and DSP processing via included RCM-24 module
- Eight recallable DSP/configuration presets
- System check button for fast, complete test of all connected cables and loudspeaker components
- Two GPI and two GPO ports
- Parallel RJ-45 CAN bus connectors
- Pilot tone detection for cable supervision

P3000RL

1800 W PER CHANNEL REMOTE CONTROL AMPLIFIER



- High-power performance and control, installed or on tour
- 1800 W per channel (2 Ω)
- Class-AB design
- IRIS-Net enabled for remote control, monitoring and DSP processing via included RCM-24 module
- Eight recallable DSP/configuration presets
- System check button for fast, complete test of all connected cables and loudspeaker components
- Two GPI and two GPO ports
- Parallel RJ-45 CAN bus connectors
- Pilot tone detection for cable supervision



| | P1200RL | | | P3000RL | | | P1200RT | |
|---|--|--------|--------|--|--------|--------|--|-------|
| Topology | Class-AB | | | Class-AB | | | Class-AB | |
| Impedance/Voltage | 2 Ω | 4 Ω | 8 Ω | 2 Ω | 4 Ω | 8 Ω | 70 V | 100 V |
| Continuous Output/Channel (1 kHz, THD 1%) | 850 W | 600 W | 380 W | 1800 W | 1300 W | 850 W | 580 W | 590 W |
| Rated Output/Channel (20 - 20,000 Hz, THD < 0.2%) | — | 500 W | 300 W | — | 1200 W | 750 W | 500 W | 500 W |
| Maximum Bridged Output (1 kHz, THD 1%) | — | 1700 W | 1200 W | — | 3600 W | 2600 W | — | — |
| Signal-to-Noise Ratio, Amplifier (A-weighted) | 106 dB | | | 109 dB | | | 106 dB | |
| Frequency Response (-1 dB) | 20–20,000 Hz | | | 20–20,000 Hz | | | 45–20,000 Hz | |
| THD @ Rated Output Power | <0.05% | | | <0.05% | | | <0.2% < 0.1% | |
| Intermodulation (SMPTE) | <0.08% | | | <0.001% | | | <0.3% < 0.1% | |
| DIM 30 | <0.03% | | | <0.01% | | | <0.3% < 0.2% | |
| Input Sensitivity and Impedance | 1.55 V (+6 dBu), 20 kΩ, XLR Input | | | 1.55 V (+6 dBu), 20 kΩ, XLR Input | | | 1.55 V (+6 dBu), 20 kΩ, XLR Input | |
| Maximum Input Level | 8.7 V (+21 dBu) | | | 8.7 V (+21 dBu) | | | 8.7 V (+21 dBu) | |
| Dynamic Audio Limiter | THD <= 1% (Input signal <= + 20 dBu) | | | THD <= 1% (Input signal <= + 20 dBu) | | | THD <= 1% (Input signal <= + 20 dBu) | |
| Serial Interface | Network: CAN, 2 RJ-45 (CAT-5 Cabling), RS-232 for media control systems | | | | | | | |
| Control Logic Inputs and Outputs | 2 x 0 V, 5 V free configurable, Easy-Remote | | | 2 x 0 V, 5 V free configurable, Easy-Remote | | | 2 x 0 V, 5 V free configurable, Easy-Remote | |
| Loudspeaker Connectors | Barrier strip | | | Speakon NL4 | | | Barrier strip | |
| Protections | High temperature, DC, HF, back EMF, peak current limiter, inrush current limiter, power-on delay | | | | | | | |
| Cooling | Front-to-rear, three 4-stage fans | | | Front-to-rear, three 4-stage fans | | | Front-to-rear, three 4-stage fans | |
| Dimensions (H x W x D) | 5.2" (3RU) x 19" x 15.4" (132.5 x 483 x 390 mm) | | | 5.2" (3RU) x 19" x 15.4" (132.5 x 483 x 390 mm) | | | 5.2" (3RU) x 19" x 15.4" (132.5 x 483 x 390 mm) | |
| Net Weight | 37.5 lb (17 kg) | | | 66.2 lb (30 kg) | | | 55.1 lb (25 kg) | |



Building on a legacy of power and performance, Q Series amps take Electro-Voice's unique amplifier philosophy to a new level of efficiency and value. The Q series achieves superb audio performance because it's designed for superior dynamic headroom and transient response, resulting in 30% greater output capability for short-duration signals. High-power Q99 and Q1212 models use sophisticated Class-H topology that dramatically reduces heat and cuts energy consumption by up to 50%, yielding racks that are easier to power and

easier to cool. Smaller Q44 and Q66 models are based on the proven Class-AB designs of EV's reference-standard Precision series. All models incorporate dynamic limiting to prevent dangerous output clipping, as well as extensive protections against thermal damage and electrical malfunction. Combining Class-H innovation with Class-AB sonic excellence and robustness, the compact, affordable Q Series is the ideal amplifier line for all sizes of clubs, concerts, performance centers and sports venues.

Q44 650 W PER CHANNEL POWER AMPLIFIER



- Outstanding value and performance for club and mobile systems
- Dynamic headroom for all real-world applications
- 650 W per channel (2 Ω)
- Class-AB design
- XLR pass-through input connections
- Easy connection to biamped loudspeakers
- Switchable LPN filter for extra tonal fundamentals and "kick"
- Protective low-cut for systems without subwoofers
- Built-in dynamic limiters
- Complete protection package
- 3-stage front-to-rear fans

Q66 900 W PER CHANNEL POWER AMPLIFIER



- Outstanding value and performance for clubs, mobile and more
- Dynamic headroom for all real-world applications
- 900 W per channel (2 Ω)
- Class-AB design
- XLR pass-through input connections
- Easy connection to biamped loudspeakers
- Switchable LPN filter for extra tonal fundamentals and "kick"
- Protective low-cut for systems without subwoofers
- Built-in dynamic limiters
- Complete protection package
- 3-stage front-to-rear fans

Q99 1250 W PER CHANNEL CLASS-H POWER AMPLIFIER



- High-efficiency power and performance
- Innovative Class-H design
- 1250 W per channel (2 Ω)
- Dynamic headroom for all real-world applications
- XLR pass-through input connections
- Easy connection to biamped loudspeakers
- Switchable LPN filter for extra tonal fundamentals and "kick"
- Protective low-cut for systems without subwoofers
- Built-in dynamic limiters
- Complete protection package
- 3-stage front-to-rear fans



Q1212

1800 W PER CHANNEL CLASS-H POWER AMPLIFIER



- Super-efficient power with outstanding performance
- Innovative Class-H design
- 1800 W per channel (2 Ω)
- Dynamic headroom for all real-world applications
- XLR pass-through input connections
- Easy connection to biamped loudspeakers
- Switchable LPN filter for extra tonal fundamentals and "kick"
- Protective low-cut for systems without subwoofers
- Built-in dynamic limiters
- Complete protection package
- 3-stage front-to-rear fans

| | Q44 | | | Q66 | | | Q99 | | | Q1212 | | |
|---|---|--------|-------|---|--------|--------|---|--------|--------|---|--------|--------|
| Topology | Class-AB | | | Class-AB | | | Class-H | | | Class-H | | |
| Impedance | 2 Ω | 4 Ω | 8 Ω | 2 Ω | 4 Ω | 8 Ω | 2 Ω | 4 Ω | 8 Ω | 2 Ω | 4 Ω | 8 Ω |
| Continuous Output Power(1 kHz, THD 1%) | 650 W | 450 W | 270 W | 900 W | 600 W | 380 W | 1250 W | 900 W | 550 W | 1800 W | 1200 W | 750 W |
| Continuous Output Power(20 - 20,000 Hz, THD < 0.2%) | — | 400 W | 200 W | — | 500 W | 250 W | — | 800 W | 400 W | — | 1100 W | 550 W |
| Maximum Bridged Output | — | 1300 W | 900 W | — | 1800 W | 1200 W | — | 2800 W | 1800 W | — | 3600 W | 2400 W |
| Amplifier Gain | 32 dB | | | 32 dB | | | 32 dB | | | 32 dB | | |
| Frequency Response | 10 Hz – 40 kHz (±1 dB) | | | 10 Hz – 40 kHz (±1 dB) | | | 10 Hz – 40 kHz (±1 dB) | | | 10 Hz – 40 kHz (±1 dB) | | |
| Signal-to-Noise Ratio (A-weighted) | 106 dB | | | 107 dB | | | 109 dB | | | 110 dB | | |
| Total Harmonic Distortion | 0.03% | | | 0.03% | | | 0.03% | | | 0.03% | | |
| Intermodulation Distortion (SMPTE) | 0.1% | | | 0.1% | | | 0.1% | | | 0.1% | | |
| DIM 30 | 0.05% | | | 0.05% | | | 0.05% | | | 0.05% | | |
| Input Impedance (Balanced) | 20 kΩ | | | 20 kΩ | | | 20 kΩ | | | 20 kΩ | | |
| Input Sensitivity | +2.2 dBu | | | +3.1 dBu | | | +5.1 dBu | | | +6.6 dBu | | |
| Maximum Input Voltage | +21 dBu (8.69 Vrms) | | | +21 dBu (8.69 Vrms) | | | +21 dBu (8.69 Vrms) | | | +21 dBu (8.69 Vrms) | | |
| Slew Rate | 25 V/μs | | | 26 V/μs | | | 27 V/μs | | | 30 V/μs | | |
| Network Control (IRIS-Net) | No | | | No | | | No | | | No | | |
| Protections | Audio limiters, high temperature, DC, HF, back EMF, peak current limiters, inrush current limiters, turn-on delay | | | | | | | | | | | |
| Cooling | Front-to-rear, 3-stage fans | | | Front-to-rear, 3-stage fans | | | Front-to-rear, 3-stage fans | | | Front-to-rear, 3-stage fans | | |
| Dimensions (H x W x D) | 3.47" x 19" x 16.63" (88.3 x 483.1 x 421.5 mm) | | | 3.47" x 19" x 16.59" (88.3 x 483.1 x 421.5 mm) | | | 3.47" x 19" x 16.59" (88.3 x 483.1 x 421.5 mm) | | | 3.47" x 19" x 16.59" (88.3 x 483.1 x 421.5 mm) | | |
| Net Weight | 27.78 lb (12.6 kg) | | | 32.63 lb (14.8 kg) | | | 35.94 lb (16.3 kg) | | | 39.02 lb (17.7 kg) | | |



Contractor Precision Series amplifiers combine top-quality performance and reliability with innovative designs perfectly tailored to the needs of professional sound installation. Available in 2RU configurations of up to eight channels, CPS amps are compact and efficient to operate, with every detail thought through from the contractor's point of view. For fast installation and setup, each model features Phoenix-type input and output connectors, programmable power-on delay, remote power-on/off, rear-mounted attenuators and switchable high-pass filters.

For worry-free dependability, there's full protection against hazards, such as excessive heat, overloads, shorts, HF, DC, back EMF and inrush current. And for the ultimate in system control and supervision, the optional RCM-810 module enables the inclusion of CPS amps in IRIS-Net networks of up to 250 devices. Offering exceptional ease, flexibility and audio performance, CPS series is the ideal installation solution for cinema, club sound, commercial sound/life safety, and performance and sports venues.

UNIQUE FLEXIBILITY THROUGH VLD

The ability to switch individually the mode of each power amp channel helps the DSA multi-channel power amplifiers to achieve a degree of flexibility never before possible. In low impedance operation ($2\ \Omega$, $4\ \Omega$, $8\ \Omega$), each channel can drive up to four $8\ \Omega$ loudspeaker cabinets. The output channels can also be paired in bridged mode. Depending upon the application, each channel can be switched individually even in high-impedance (Hi-Z) mode in order to drive 70 Vrms or 100 Vrms loudspeaker lines directly without an output transformer (Direct Drive). The power output by the DSA multi-channel power amplifiers is (along with its thermal capacity) limited only by their maximum output voltage and maximum output current, which means they can drive any load between 2 and $10\ \Omega$ with their rated maximum outputs of 500 W and 1000 W respectively per channel.

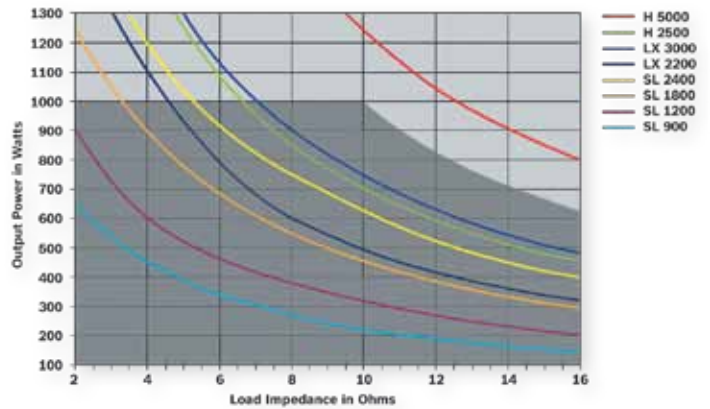

A corresponding encoder-circuit is provided on the rear panel. In addition, through VLD (Variable Load Drive) in combination with a RCM-810 remote control module, it is possible to define freely which output power should be made available at which load in the frame described above in the channel in question: e.g. Channel A = 350 W into $2.6\ \Omega$; Channel B = 500 W into $8\ \Omega$, etc.

CPS 2.4

650 W PER CHANNEL POWER AMPLIFIER



- Contractor-friendly performance and reliability
- 650 W per channel ($2\ \Omega$)
- Slot for optional RCM-810 module, allowing IRIS-Net control and monitoring
- Rear-mounted attenuators
- Switchable 50 Hz high-pass filter
- Class-AB design
- Complete protection: thermal, overload, shorts, HF, DC, back EMF and inrush current
- Phoenix-type input and output connections
- Remote power-on/off contact
- Programmable power-on delay settings
- 3-stage front-to-rear fans

CPS 2.6

900 W PER CHANNEL POWER AMPLIFIER



- Contractor-friendly performance and reliability
- 900 W per channel ($2\ \Omega$)
- Slot for optional RCM-810 module, allowing IRIS-Net control and monitoring
- Rear-mounted attenuators
- Switchable 50 Hz high-pass filter
- Class-AB design
- Complete protection: thermal, overload, shorts, HF, DC, back EMF and inrush current
- Phoenix-type input and output connections
- Remote power-on/off contact
- Programmable power-on delay settings
- 3-stage front-to-rear fans

CPS 2.9**1250 W PER CHANNEL CLASS-H POWER AMPLIFIER**

- Power and efficiency for installations
- Innovative Class-H design
- 1250 W per channel (2 Ω)
- Slot for optional RCM-810 module, allowing IRIS-Net control and monitoring
- Rear-mounted attenuators
- Switchable 50 Hz high-pass filter
- Complete protection: thermal, overload, shorts, HF, DC, back EMF and inrush current
- Phoenix-type input and output connections
- Remote power-on/off contact
- Programmable power-on delay settings
- 3-stage front-to-rear fans

CPS 2.12**1800 W PER CHANNEL CLASS-H POWER AMPLIFIER**

- Power and efficiency for installations
- Innovative Class-H design
- 1800 W per channel (2 Ω)
- Slot for optional RCM-810 module, allowing IRIS-Net control and monitoring
- Rear-mounted attenuators
- Switchable 50 Hz high-pass filter
- Complete protection: thermal, overload, shorts, HF, DC, back EMF and inrush current
- Phoenix-type input and output connections
- Remote power-on/off contact
- Programmable power-on delay settings
- 3-stage front-to-rear fans

CPS 4.5**500 W PER CHANNEL 4-CHANNEL AMPLIFIER**

- Four channels in one compact rack-efficient unit
- 500 W per channel
- 70/100 V operation for distributed systems
- Class-D design for optimum efficiency
- Slot for optional RCM-810 module, allowing IRIS-Net control and monitoring
- IRIS-Net selection of each channel's impedance (2–10 Ω in 0.1 Ω steps)
- Rear-mounted attenuators
- Switchable 50 Hz high-pass filter (Hi-Z mode)
- Complete protection: thermal, overload, shorts, HF, DC, back EMF and inrush current
- Phoenix-type input and output connections
- Remote power-on/off contact
- Programmable power-on delay settings
- Front-to-rear fans

CPS 4.10**1000 W PER CHANNEL 4-CHANNEL AMPLIFIER**

- Four channels in one compact rack-efficient unit
- 1000 W per channel
- 70/100 V operation for distributed systems
- Class-D design for optimum efficiency
- Slot for optional RCM-810 module, allowing IRIS-Net control and monitoring
- IRIS-Net selection of each channel's impedance (2–10 Ω in 0.1 Ω steps)
- Rear-mounted attenuators
- Switchable 50 Hz high-pass filter (Hi-Z mode)
- Complete protection: thermal, overload, shorts, HF, DC, back EMF and inrush current
- Phoenix-type input and output connections
- Remote power-on/off contact
- Programmable power-on delay settings
- Front-to-rear fans

CPS 8.5**500 W PER CHANNEL 8-CHANNEL AMPLIFIER**

- Eight channels in one compact rack-efficient unit
- 500 W per channel
- 70/100 V operation for distributed systems
- Class-D design for optimum efficiency
- Slot for optional RCM-810 module, allowing IRIS-Net control and monitoring
- IRIS-Net selection of each channel's impedance (2–10 Ω in 0.1 Ω steps)
- Rear-mounted attenuators
- Switchable 50 Hz high-pass filter (Hi-Z mode)
- Complete protection: thermal, overload, shorts, HF, DC, back EMF and inrush current
- Phoenix-type input and output connections
- Remote power-on/off contact
- Programmable power-on delay settings
- Front-to-rear fans

RCM-810**IRIS-NET REMOTE CONTROL MODULE FOR CPS SERIES AMPLIFIERS**

- Enable powerful control and supervision capabilities
- Integrate up to 100 devices in each remote control network, 250 with multiple networks
- Support for 2-, 4- and 8-channel CPS models
- Freely programmable control inputs and outputs
- Load-monitoring for each channel
- Variable Load Drive for independent channel impedance on 4- and 8-channel amps (2–10 Ω in 0.1 Ω steps)

| | CPS 2.4 | | | CPS 2.6 | | | CPS 2.9 | | | CPS 2.12 | | |
|---|---|--------|-------|---|--------|--------|---|--------|--------|---|--------|--------|
| Topology | Class-AB | | | Class-AB | | | Class-H | | | Class-H | | |
| Impedance | 2 Ω | 4 Ω | 8 Ω | 2 Ω | 4 Ω | 8 Ω | 2 Ω | 4 Ω | 8 Ω | 2 Ω | 4 Ω | 8 Ω |
| Continuous Output Power(1 kHz, THD 1%) | 650 W | 450 W | 270 W | 900 W | 600 W | 380 W | 1250 W | 900 W | 550 W | 1800 W | 1200 W | 750 W |
| Continuous Output Power(20–20,000 Hz, THD<0,2%) | — | 400 W | 200 W | — | 500 W | 250 W | — | 800 W | 400 W | — | 1100 W | 550 W |
| Maximum Bridged Output | — | 1300 W | 900 W | — | 1800 W | 1200 W | — | 2800 W | 1800 W | — | 3600 W | 2400 W |
| Amplifier Gain | 32 dB | | | 32 dB | | | 32 dB | | | 32 dB | | |
| Frequency Response | 10–40,000 Hz (±1 dB) | | | 10–40,000 Hz (±1 dB) | | | 10–40,000 Hz (±1 dB) | | | 10–40,000 Hz (±1 dB) | | |
| Total Harmonic Distortion | 0.03% | | | 0.03% | | | 0.03% | | | 0.03% | | |
| Intermodulation Distortion (SMPTE) | 0.1% | | | 0.05% | | | 0.1% | | | 0.1% | | |
| DIM 30 | 0.05% | | | 0.02% | | | 0.05% | | | 0.05% | | |
| Slew Rate | 25 V/μs | | | 26 V/μs | | | 27 V/μs | | | 30 V/μs | | |
| Analog Inputs | 2, electronically balanced, Phoenix-type | | | 2, electronically balanced, Phoenix-type | | | 2, electronically balanced, Phoenix-type | | | 2, electronically balanced, Phoenix-type | | |
| Input Impedance (Balanced) | 20 kΩ | | | 20 kΩ | | | 20 kΩ | | | 20 kΩ | | |
| Input Sensitivity | 2.2 dBu (1.0 V) | | | +3.1 dBu (1.11 Vrms) | | | +5.1 dBu (1.39 Vrms) | | | +6.6 dBu (1.66 Vrms) | | |
| Maximum Input Voltage | +21 dBu (8.69 Vrms) | | | +21 dBu (8.69 Vrms) | | | +21 dBu (8.69 Vrms) | | | +21 dBu (8.69 Vrms) | | |
| Crossover Type | Optional Modules | | | Optional Modules | | | Modular | | | Modular | | |
| Network Control (IRIS-Net) | Optional (RCM-810 card) | | | Optional (RCM-810 card) | | | Optional (RCM-810 card) | | | Optional (RCM-810 card) | | |
| CAN Bus Interface | Optional (RCM-810 card) | | | Optional (RCM-810 card) | | | Optional (RCM-810 card) | | | Optional (RCM-810 card) | | |
| Variable Load Drive (VLD) | No | | | No | | | No | | | No | | |
| Cooling | Front-to-rear, 3-stage fans | | | Front-to-rear, 3-stage fans | | | Front-to-rear, 3-stage fans | | | Front-to-rear, 3-stage fans | | |
| Dimensions (H x W x D) | 3.47" x 19" x 16.59" (88.1 x 482.6 x 421.5 mm) | | | 3.47" x 19" x 16.59" (88.1 x 482.6 x 421.5 mm) | | | 3.47" x 19" x 16.59" (88.1 x 482.6 x 421.5 mm) | | | 3.47" x 19" x 16.59" (88.1 x 482.6 x 421.5 mm) | | |
| Net Weight | 13.23 lb (6 kg) | | | 32.63 lb (14.8 kg) | | | 35.94 lb (16.3 kg) | | | 15.43 lb (7 kg) | | |

| | CPS 4.10 | | | | | CPS 4.5 | | | | | CPS 8.5 | | | | |
|---|--|--------|--------|---------|----------|--|--------|--------|---------|----------|--|--------|--------|---------|----------|
| Topology | Class-D | | | | | Class-D | | | | | Class-D | | | | |
| Impedance/Voltage | 2 Ω | 4 Ω | 8 Ω | 8 Ω VLD | 70V/100V | 2 Ω | 4 Ω | 8 Ω | 8 Ω VLD | 70V/100V | 2 Ω | 4 Ω | 8 Ω | 8 Ω VLD | 70V/100V |
| Continuous Power/Channel (1 kHz, THD 1%) | 1000 W | 1000 W | 500 W | 1000 W | 1000 W | 500 W | 500 W | 250 W | 500 W | 500 W | 500 W | 500 W | 250 W | 500 W | 500 W |
| Continuous Power/Channel (20-20,000 Hz, THD < 0.3%) | 900 W | 900 W | 450 W | 900 W | 900 W | 450 W | 450 W | 225 W | 450 W | 450 W | 450 W | 450 W | 225 W | 450 W | 450 W |
| Maximum Bridged Output | — | 2000 W | 2000 W | — | 2000 W | — | 1000 W | 1000 W | — | 1000 W | — | 1000 W | 1000 W | — | 1000 W |
| Amplifier Gain | 32 dB (Lo-Z), 33 dB (70 V), 36 dB (100 V) | | | | | 32 dB (Lo-Z), 33 dB (70 V), 36 dB (100 V) | | | | | 32 dB (Lo-Z), 33 dB (70 V), 36 dB (100 V) | | | | |
| Frequency Response | 15–30,000 Hz | | | | | 15–30,000 Hz | | | | | 15–30,000 Hz | | | | |
| Signal-to-Noise Ratio, A-weighted (4 Ω) | 103 dB | | | | | 100 dB | | | | | 100 dB | | | | |
| Total Harmonic Distortion | 0.05% | | | | | 0.05% | | | | | 0.05% | | | | |
| Intermodulation Distortion (SMPTE) | 0.05% | | | | | 0.05% | | | | | 0.05% | | | | |
| DIM 30 | 0.02% | | | | | 0.02% | | | | | 0.02% | | | | |
| Slew Rate | 28 V/μs | | | | | 28 V/μs | | | | | 28 V/μs | | | | |
| Analog Inputs | 4, electronically balanced, Phoenix-type | | | | | 4, electronically balanced, Phoenix-type | | | | | 8, electronically balanced, Phoenix-type | | | | |
| Input Impedance (Balanced) | 20 kΩ | | | | | 20 kΩ | | | | | 20 kΩ | | | | |
| Input Sensitivity | 0 dBu (.775 V)-2 Ω, +3 dBu (1.1 V)-4/8 Ω, +6 dBu (1.55) 70V/100V | | | | | 0 dBu (.775 V)-2 Ω, +3 dBu (1.1 V)-4/8 Ω, +6 dBu (1.55) 70V/100V | | | | | 0 dBu (.775 V)-2 Ω, +3 dBu (1.1 V)-4/8 Ω, +6 dBu (1.55) 70V/100V | | | | |
| Maximum Input Voltage | +22 (9.76 Vrms) | | | | | +22 (9.76 Vrms) | | | | | +22 (9.76 Vrms) | | | | |
| Network Control (IRIS-Net) | Optional (RCM-810 card) | | | | | Optional (RCM-810 card) | | | | | Optional (RCM-810 card) | | | | |
| CAN Bus Interface | Optional (RCM-810 card) | | | | | Optional (RCM-810 card) | | | | | Optional (RCM-810 card) | | | | |
| Variable Load Drive (VLD) | Yes | | | | | Yes | | | | | Yes | | | | |
| Cooling | Front-to-rear, continuously variable fans | | | | | Front-to-rear, continuously variable fans | | | | | Front-to-rear, continuously variable fans | | | | |
| Dimensions (H x W x D) | 3.47" x 19" x 16.59" (88.1 x 482.6 x 421.5 mm) | | | | | 3.47" x 19" x 16.59" (88.1 x 482.6 x 421.5 mm) | | | | | 3.47" x 19" x 16.59" (88.1 x 482.6 x 421.5 mm) | | | | |
| Net Weight | 24.47 lb (11.1 kg) | | | | | 24.47 lb (11.1 kg) | | | | | 30.64 lb (13.9 kg) | | | | |



CP
Compact Precision

Compact Precision amplifiers combine outstanding audio performance with the highest-possible reliability and safety to create an ideal high-power solution for touring and rentals. Incorporating an innovative switchmode power supply into Class-H technology, the CP series delivers clean headroom that is far above stated nominal output. This advanced design also results in improved performance-to-weight ratio for easier touring, reduced waste heat for closer rack spacing and reduced power

consumption for enhanced energy efficiency. A complete set of protection circuitry guards people and equipment against hazardous conditions, and a rigid, robust chassis, built to the highest precision manufacturing standards, ensures dependable operation on even the most grueling tours. With exceptionally clean power and tour-friendly touches that facilitate fast, flexible setup, Compact Precision amplifiers fulfill even the most demanding requirements of pro audio touring.

CP3000S

1600 W PER CHANNEL CLASS-H POWER AMPLIFIER



- Advanced high-efficiency Class-H design
- Ideal for demanding concerts and tours
- Exceptional dynamic headroom
- Rugged, compact and lightweight
- 1600 W per channel (2 Ω)
- XLR pass-through input connections
- Easy connection to biamped loudspeakers
- Switch mode power supply
- Built-in dynamic limiters
- Complete protection: thermal, overload, shorts, HF, DC, back EMF and inrush current
- 3-stage front-to-rear fans

CP4000S

2100 W PER CHANNEL CLASS-H POWER AMPLIFIER



- High power with advanced Class-H efficiency
- Ideal for demanding concerts and tours
- Exceptional dynamic headroom
- Rugged, compact and lightweight
- 2100 W per channel (2 Ω)
- XLR pass-through input connections
- Easy connection to biamped loudspeakers
- Switch mode power supply
- Built-in dynamic limiters
- Complete protection: thermal, overload, shorts, HF, DC, back EMF and inrush current
- 3-stage front-to-rear fans

| | CP3000S | | | CP4000S | | |
|---|---|------------|------------|--|------------|------------|
| Topology | Class-H | | | Class-H | | |
| Impedance | 2 Ω | 4 Ω | 8 Ω | 2 Ω | 4 Ω | 8 Ω |
| Maximum power (1k Hz; THD < 1%) | 1600 W | 1100 W | 600 W | 2100 W | 1500 W | 900 W |
| Rated power (20 Hz–20,000 Hz; THD < 0.2%) | — | 900 W | 450 W | — | 1200 W | 600 W |
| Maximum bridged output (1,000 Hz; < 1% THD) | — | 3200 W | 2200 W | — | 4200 W | 3000 W |
| Frequency Response (-1dB, ref. 1kHz) | 15–40,000 Hz | | | 15–40,000 Hz | | |
| Signal-to-noise ratio, A-weighted | 107 dB | | | 108 dB | | |
| Total harmonic distortion | <0.05% | | | <0.05% | | |
| Intermodulation distortion (SMPTE) | <0.02% | | | <0.02% | | |
| Slew rate | 35 V/ μ s | | | 35 V/ μ s | | |
| Input impedance (balanced) | 20 k Ω | | | 20 k Ω | | |
| Crosstalk (at 1,000 Hz) | <-80 dB | | | <-80 dB | | |
| Dimensions (W x H x D) | 19" x 3.5" x 15.22" (483 x 88.1 x 384 mm) | | | 19" x 3.5" x 15.5" (483 x 88.1 x 384 mm) | | |
| Net weight | 17.97 lb (8.15 kg) | | | 19.18 lb (8.70 kg) | | |

PA Series



The PA Series of commercial power amplifiers is a favorite of installers everywhere for sound reinforcement, background music, paging and public address systems. Featuring low-distortion amplifier electronics that are bridgeable for flexible power allocation, PA Series amps provide a wide dynamic range with excellent headroom. An onboard limiter spares both amplifier and speakers from damaging transients, and a comprehensive thermal/electrical protection package ensures long-haul dependability. Equipped with Phoenix-style terminals for

fast, easy hookup, PA Series amps are housed in compact, rack-ready 2RU chassis with ample internal airflow and exceptionally quiet multi-stage fans. Models are available in a variety of output powers and channel configurations, several of which provide 70 V/100 V output using low-distortion transformers. Offering outstanding versatility and long-term reliability, the PA Series is a remarkable value for any installation application.

PA1250T

SINGLE-CHANNEL 250 W POWER AMPLIFIER



- Cool-running, saturation-free power for distributed installations
- Ideal for sound reinforcement, paging and life safety
- 250 W mono for 70 V/100 V lines
- Compact 2RU design
- Stepped rear-panel level attenuation
- Selectable 50 Hz or 300 Hz high-pass filter
- Thermal protection, peak limiting, turn-on delay
- Phoenix-type inputs and outputs
- 3-stage front-to-rear fans
- Integrated rack ears for direct mounting

PA2250T

DUAL 270 W PER CHANNEL POWER AMPLIFIER



- Efficient performance for low impedance or distributed systems
- Ideal for sound reinforcement, paging and life safety
- 250 W per channel for 4 Ω or 70 V/100 V lines
- Bridged mono out for 540 W into 8 Ω
- Compact 2RU design
- Stepped rear-panel level attenuation
- Selectable 50 Hz or 300 Hz high-pass filter
- Thermal protection, peak limiting, turn-on delay
- Phoenix-type inputs and outputs
- 3-stage front-to-rear fans
- Integrated rack ears for direct mounting

PA2400T

DUAL 400 W PER CHANNEL POWER AMPLIFIER



- Efficient performance for low impedance or distributed systems
- Ideal for sound reinforcement, paging and life safety
- 400 W per channel for 4 Ω or 70 V/100 V lines
- Bridged mono out for 860 W into 8 Ω
- Compact 2RU design
- Stepped rear-panel level attenuation
- Selectable 50 Hz or 300 Hz high-pass filter
- Thermal protection, peak limiting, turn-on delay
- Phoenix-type inputs and outputs
- 3-stage front-to-rear fans
- Integrated rack ears for direct mounting

PA2450L

DUAL 450 W PER CHANNEL POWER AMPLIFIER



- Reliable high-quality power for installation
- Ideal for sound reinforcement, paging and life safety
- 450 W per channel for 4 Ω or 70 V/100 V lines
- Bridged mono out for 900 W into 8 Ω
- Compact 2RU design
- Stepped rear-panel level attenuation
- Selectable 50 Hz or 300 Hz high-pass filter
- Thermal protection, peak limiting, turn-on delay
- Phoenix-type inputs and outputs
- 3-stage front-to-rear fans
- Integrated rack ears for direct mounting

PA4150L

QUAD 150 W PER CHANNEL POWER AMPLIFIER



- Flexible multi-channel power for installation
- Ideal for sound reinforcement, paging and life safety
- 150 W per channel into 4 Ω
- Bridged mode for dual 315 W outputs into 8 Ω
- Compact 2RU design
- Stepped rear-panel level attenuation
- Selectable 50 Hz or 300 Hz high-pass filter
- Thermal protection, peak limiting, turn-on delay
- Phoenix-type inputs and outputs
- 3-stage front-to-rear fans
- Integrated rack ears for direct mounting

| | PA1250T | PA2250T | | PA2400T | | | PA2450L | | PA4150L | | |
|--|---|---|-------|---|-------|-------|---|-------|---|-------|-------|
| Number of Channels | 1 | 2 | | 2 | | | 2 | | 4 | | |
| Signal-to-Noise Ratio, A-weighted | 103 dB | 103 dB | | 103 dB | | | 104 dB | | 101 dB | | |
| Impedance/Voltage | 70 V/100 V | 4 Ω | 8 Ω | 70 V/100 V | 4 Ω | 8 Ω | 70 V/100 V | 4 Ω | 8 Ω | 4 Ω | 8 Ω |
| Rated output power (*rated load) THD <1%, 1 kHz | 270 W | 270 W | 135 W | 270 W | 430 W | 215 W | 430 W | 450 W | 220 W | 160 W | 100 W |
| Rated output power (*rated load) THD <0.2%, 20 Hz – 20 kHz | 250 W | 250 W | 125 W | 250 W | 400 W | 200 W | 400 W | 400 W | 200 W | 150 W | 75 W |
| Slew rate (V/μs) at 1 kHz | 41/61 | 18 | 18 | 41/61 | 25 | 25 | 46/65 | 28 | 28 | 16 | 16 |
| Frequency response -1 dB, ref. 1 kHz | 65 Hz – 20 kHz | 65 Hz – 40 kHz | | 65 Hz – 40 kHz | | | <10 Hz – 40 kHz | | <10 Hz – 40 kHz | | |
| THD @ rated output power MBW=80 kHz, 1 kHz | <0.1% | <0.1% | | <0.1% | | | <0.1% | | <0.1% | | |
| IMD-SMPTE 60 Hz, 7 kHz | <0.1% | <0.1% | | <0.1% | | | <0.1% | | <0.1% | | |
| DIM30 3.15 kHz, 1.5 kHz | <0.1% | <0.1% | | <0.1% | | | <0.1% | | <0.1% | | |
| Input impedance, 20–20,000 Hz | >20 kΩ balanced | >20 kΩ | | >20 kΩ | | | >20 kΩ | | >20 kΩ | | |
| Input sensitivity @ rated output power or voltage, 1 kHz | 0 dBu (775 mV) | 0 dBu (775 mV) | | 0 dBu (775 mV) | | | 0 dBu (775 mV) | | 0 dBu (775 mV) | | |
| Crosstalk ref. 1 kHz, @ 10% rated output power | <-75 dB | <-75 dB | | <-75 dB | | | <-75 dB | | <-75 dB | | |
| Dimensions (W x H x D) | 19" x 3.5" x 16" (483 x 88 x 406 mm) | 19" x 3.5" x 16" (483 x 88 x 406 mm) | | 19" x 3.5" x 16" (483 x 88 x 406 mm) | | | 19" x 3.5" x 16" (483 x 88 x 406 mm) | | 19" x 3.5" x 16" (483 x 88 x 406 mm) | | |
| Net Weight | 36.34 lb (16.5 kg) | 51.76 lb (23.5 kg) | | 57.27 lb (26 kg) | | | 36.34 lb (16.5 kg) | | 39.65 lb (18 kg) | | |



The NetMax N8000 System Controller is a state-of-the-art digital matrix system offering comprehensive management of all aspects of professional sound reinforcement systems. Supporting both distributed and central processing, NetMax is a powerful physical complement to EV's IRIS-Net protocol, which gives designers and end-users the industry's most flexible routing, DSP, and component-level system control and supervision. EQ, crossovers, dynamics, FIR-Drive loudspeaker optimization—NetMax does it all with superior digital fidelity.

Each 2RU NetMax chassis supports up to 1900 MIPS of processing power and up to 32 local audio channels. And with NetMax's modular, field-configurable architecture, every system can be tailored to current needs without being locked out of future expansion. Designed for both installations and touring systems, NetMax is an indispensable tool for concert halls, houses of worship, hotels, casinos, convention centers, sporting arenas and stadiums. Simply put, there's no more powerful, intelligent way to tame the complexity of modern sound systems than NetMax.

N8000

NETMAX 300 MIPS DIGITAL MATRIX CONTROLLER



- Full IRIS-Net supervision, control and scheduling
- Comprehensive 32-channel routing and mixing
- Huge range of DSP filters, EQ, dynamics and delays
- FIR-Drive loudspeaker optimization
- 300 MIPS internal processing
- Up to 1000 MIPS of processing power available per unit
- 115 dB dynamic range for clean, quiet sound
- Internal 48-bit processing for outstanding audio fidelity
- Auto-compiling DSP engine with ultra-low fixed latency
- Modular architecture with hardware expansion slots
- Fully-programmable analog and digital GPIO support
- Support for Ethernet, RS-232, USB and CAN
- CobraNet and Dante audio networking options

DSP-1

N8000 300 MIPS DSP EXPANSION MODULE

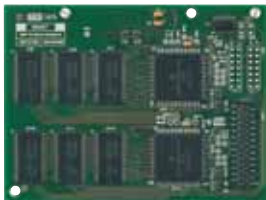

- Enhanced DSP power for NetMax controllers
- Adds 300 MIPS computing capacity
- Easy field installation into chassis card slot
- 48-bit signal processing
- Two RAM banks (512 k x 24 bit) for delay lines up to 21.8 seconds
- Double-precision DSP algorithms
- Automatic configuration via IRIS-Net with installation/removal notification

DSP-2

N8000 1500 MIPS DSP EXPANSION MODULE



- Enhanced DSP power for NetMax controllers
- Adds 1500 MIPS computing capacity
- Easy field installation into chassis card slot
- Three additional RAM banks (512 k x 24 bit) for delay lines up to 32.7 seconds
- Double-precision DSP algorithms
- Automatic configuration via IRIS-Net with installation/removal notification

PWS-4 PWS-6 PWS-C

PROGRAMMABLE WALL STATIONS



- Modular standard-mount keypads for NetMax
- Convenient control for volume, source, presets, etc.
- Up to three front units in a wall station
- PWS-C connects front units to CAN bus
- Easy daisy-chaining with included connection wire
- Easy labeling, protected by transparent cover
- Integrated status LEDs
- Button and LED configuration via IRIS-Net
- Customizable button behavior (momentary, latching or radio)

AI-1 NETMAX 8-CHANNEL ANALOG INPUT CARD



- Eight electronically balanced line-level inputs
- Euroblock connectors
- 20 kΩ input impedance
- 117 dB dynamic range for superior sonic quality
- Automatic configuration
- IRIS-Net notification of installation and removal
- On-board DSP (100 MIPS)

MI-1 NETMAX 8-CHANNEL ANALOG MIC/LINE INPUT CARD



- Eight electronically balanced mic/line inputs
- Euroblock connectors
- 48 V phantom power
- Mic/line pad, selectable via IRIS-Net
- Gain and level adjustable via IRIS-Net
- Automatic configuration
- IRIS-Net notification of installation and removal
- On-board DSP (100 MIPS)

DI-1 NETMAX 8-CHANNEL DIGITAL INPUT CARD



- Eight channels of AES/EBU or S/PDIF digital audio
- Four input connectors, Euroblock or TOSLINK optical
- Supports sample rates from 32–192 kHz
- Independent sample rate conversion for each input
- Lock indication LED
- On-board DSP (100 MIPS)

AO-1 NETMAX 8-CHANNEL ANALOG OUTPUT CARD



- Eight electronically balanced line-level outputs
- Euroblock connectors
- 118 dB dynamic range for superior sonic quality
- 100 Ω output impedance
- Automatic configuration
- IRIS-Net notification of installation and removal
- On-board DSP (100 MIPS)

DO-1 NETMAX 8-CHANNEL DIGITAL OUTPUT CARD



- Eight channels of AES/EBU digital audio output
- Four Euroblock output connectors
- 48 kHz sample rate
- +21 dBu maximum output level
- Automatic configuration via IRIS-Net with installation/removal notification
- On-board DSP (100 MIPS)

CM-1 NETMAX COBRANET AUDIO NETWORK MODULE



- Connect NetMax to a CobraNet digital audio network
- Two 100BASE-TX Ethernet interfaces (IEEE 802.3u compatible) for system redundancy
- 100 mbps data transmission rate
- Four serial ports each for input and output for a total of up to 32 ins and 32 outs
- 48 kHz sample rate and 16-, 20- or 24-bit word-length
- Control, monitoring, configuration and firmware updates via Ethernet
- Status LEDs for link, activity, fault and CobraNet conductor status

DM-1 NETMAX DANTE AUDIO NETWORK MODULE



- Connect NetMax to a Dante digital audio network
- Transmit up to 32 ins and 32 outs at 48 kHz sample rate and 16-, 20- or 24-bit word-length
- Low latency (typically below 1 ms)
- Two Gigabit Ethernet interfaces for system redundancy
- Status LEDs for each interface
- Dante Zen device-discovery
- Compatible with Dante Virtual Soundcard



Proven in thousands of installations and live applications around the world, EV delivers truly state-of-the-art DSP for today's applications. EV's Dx46 sets the standard for digital

loudspeaker controllers, providing 48-bit filter algorithms, 24-bit AD/DA conversion and a dynamic range of 115 dB.

Dx46

TWO-IN/SIX-OUT FIR-DRIVE SOUND SYSTEM PROCESSOR



- IRIS-Net software provides complete control, monitoring and supervision
- FIR-Drive loudspeaker optimization
- Analog and AES/EBU inputs
- Switchable -6 dB pre-A/D converter pad
- 24-bit AD/DA conversion
- 48-bit filter algorithms
- 115 dB dynamic range
- Ethernet and USB data interfaces
- Dedicated array EQ and delay sections
- 4 separate delay sections
- 5 contact closure inputs
- 60 factory presets, 30 user presets
- Unique edit/compare mode for audible parameter adjustment
- Full loudspeaker protection package, including both Peak Anticipation and TEMP limiters
- Editor Software IRIS-Net

DC-One

TWO-IN/SIX-OUT SOUND SYSTEM PROCESSOR



- DC-One Editor Software control via USB port
- Analog or AES/EBU Inputs
- Switchable -6 dB pre-A/D converter pad
- 24-bit AD/DA conversion
- 32-bit Floating Point internal processing
- 111 dB dynamic range
- Six predefined operation configurations
- Contact closure interface for remote preset recall
- 60 factory presets, 20 user presets
- Unique edit/compare mode for audible parameter adjustment
- Highly-customizable security settings

DC-One Editor Software PC-BASED EDITING SOFTWARE FOR DC-ONE



- Easy connection to DC-One hardware via USB
- Detailed, real-time control and supervision of DC-One hardware
- Intuitive user interface
- State-of-the-art graphics provide detailed, easy-to-understand system overview
- Graphical navigation and block diagrams provide easy access to all functions and DSP sections
- Unique delay adjustment interface positions components as they actually exist in space
- Selective lockout of front-panel access protects settings from tampering
- Available as a free download at www.electro-voice.com



| | Dx46 | DC-One |
|--|---|--|
| Analog Inputs (Electronically Balanced) | Two XLR, Two XLR THRU OUT | Two XLR, Two XLR THRU OUT |
| Analog Outputs (Electronically Balanced) | Six XLR | Six XLR |
| Digital Inputs | XLR AES/EBU (2-channel) | XLR AES/EBU (2-channel) |
| Maximum Input Voltage | 8.7 V/+21 dBu (analog pad not engaged) | 8.7 V/+21 dBu (analog pad not engaged) |
| Nominal Input Voltage | 1.55 V/+ 6 dBu | 1.23 V/+4 dBu |
| Input Impedance (Balanced) | 10 kΩ | 10 kΩ |
| Maximum Output Voltage | 8.7 V/+21 dBu | 8.7 V/+21 dBu |
| Nominal Output Voltage | 1.55 V/+6 dBu | 1.23 V/+4 dBu |
| Output Impedance (Balanced) | 50 Ω | 50 Ω |
| Frequency Response | 20 Hz – 22 kHz (+/-0.5 dB) | 10–22,000 Hz (±0.5 dB) |
| Dynamic Range | 116 dB (A-weighted) | 111 dB (unweighted, band limited 22–22,000 Hz) |
| THD+N | <0.002% (band limited 20–20,000 Hz) | <0.01% (band limited 22–22,000 Hz) |
| A/D Conversion | 24-bit Delta Sigma | 24-bit/Sigma-Delta (linear phase) 128 times oversampling |
| D/A Conversion | 24-bit Delta Sigma | 24-bit/Sigma-Delta 128 times oversampling |
| Data Format | 24-bit | 24-bit |
| Internal Processing | 48-bit double precision | 32-bit floating point |
| Sample Rate | 48 kHz | 48 kHz |
| Control Protocol | USB, Ethernet | Front-panel USB port |
| Dimensions (H x W x D) | 1.74" x 19" x 14" (44.25 x 482.6 x 355.6 mm) | 1.74" x 19" x 14" (44.25 x 482.6 x 355.6 mm) |
| Net Weight | 10.14 lb (4.6 kg) | 10.14 lb (4.6 kg) |



Headquarters Americas:
Bosch Security Systems, Inc.
12000 Portland Ave South
Burnsville, MN 55337, USA
USA-Ph: 1 800 392 3497
Fax: 1 800 955 6831
Canada-Ph: 1 866 505 5551
Fax: 1 866 336 8467
Latin America-Ph: 1 952 887 5532
Fax: 1 952 736 4212