

# SERVICE MANUAL

## XB-2, XB-2N

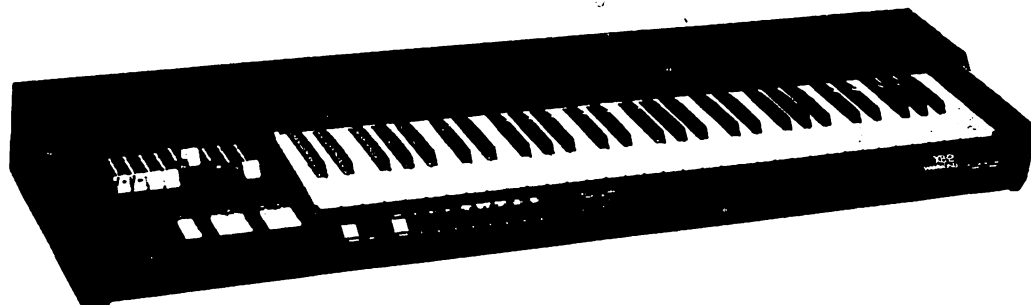

CAUTION !  
see safety notice inside

May, 1991

**S** HAMMOND SUZUKI, LTD.  
733 Annoreno Drive  
Addison, IL 60101

### SAFETY NOTICE

Great care has been taken in the design and manufacture of this product to assure that no shock hazard exists on any exposed metal parts. Internal service operations can expose the technician to hazardous line voltages and accidentally cause these voltages to appear on exposed metal parts during repair or reassembly of product components. To prevent this, work on these products should only be performed by those who are thoroughly familiar with the precautions necessary when working on this type of equipment.

To protect the user, it is required that all enclosure parts and safety interlocks be restored to their original condition and the following tests be performed before returning the product to the owner after any service operation.

Plug the AC line cord directly into a line voltage AC receptacle (do not use an isolation transformer for this test) and turn the product on. Connect the network (as shown below) in series with all exposed metal parts and a known earth ground such as a water pipe or conduit. Use an AC VOM of 5,000 ohms per volt or higher sensitivity to measure the voltage drop across the network. Move the network connection to each exposed metal part (metal chassis, screw heads, knobs and control shafts, escutcheon, etc.) and measure the voltage drop across the network. Reverse the line plug and repeat the measurements. Any reading of 4 volts RMS or more is excessive and indicates a potential shock hazard which must be corrected before returning the product to the user.

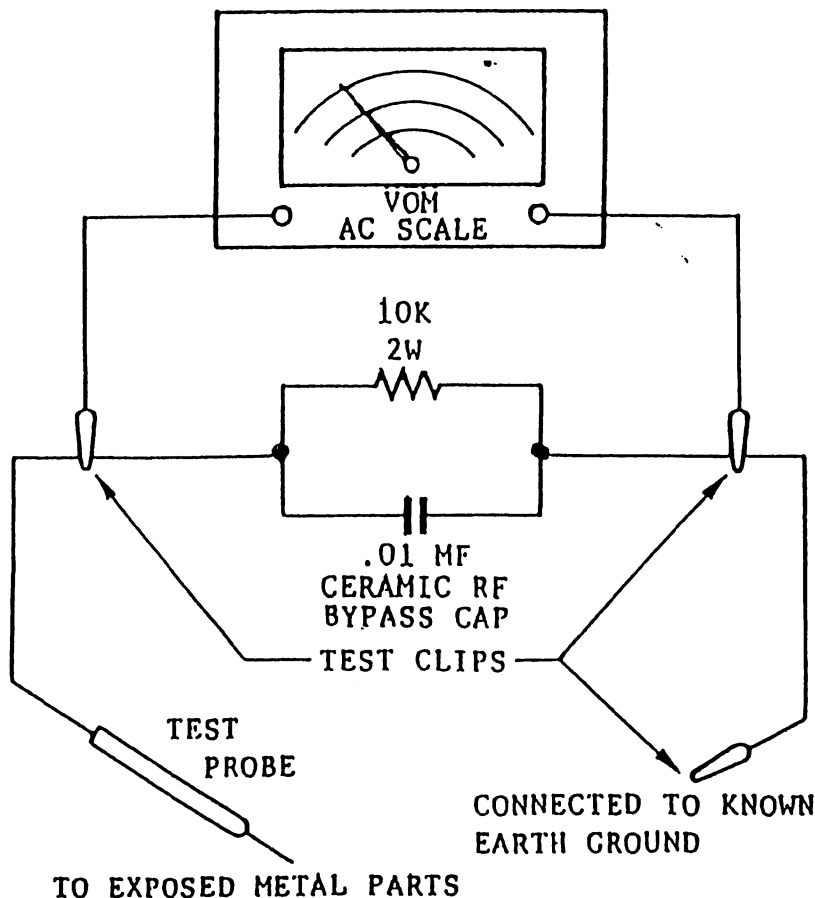

### CAUTION

Danger of explosion if battery is incorrectly replaced. Replace only with the same or equivalent type recommended by the equipment manufacturer. Discard used batteries according to manufacturer's instructions.

## TABLE OF CONTENTS

1. SPECIFICATIONS & LCD MAP . . . . .	1-1, 1-2
2. BLOCK DIAGRAM . . . . .	2
3. MASTER GEN. LOGIC . . . . .	3
4. DISASSEMBLY PROCEDURE . . . . .	4
5. TEST AND ADJUSTMENT PROCEDURE . . . . .	5
6. MIDI IMPLEMENTATION CHART . . . . .	6
7. SUB WIRING CHART . . . . .	7
8. WIRING CHART . . . . .	8
9. PRINTED WIRING BOARD ASS'Y LIST . . . . .	9
10. PWB SCHEMATICS	
MGH-61A . . . . .	10-1/3, 10-2/3, 10-3/3
SWK-290C . . . . .	10-2
PSH-72A . . . . .	10-3
SWH-400A . . . . .	10-4
SWH-401A . . . . .	10-5
SWH-402A . . . . .	10-6
FLH-45A . . . . .	10-7
MXH-16A . . . . .	10-8
EFH-221C . . . . .	10-9
EFH-227A . . . . .	10-10
11. ALL RESET . . . . .	11
12. SOFTWARE VERSION . . . . .	12-1, 12-2, 12-3
13. MEMORY DUMP . . . . .	13
14. ERROR MESSAGES . . . . .	14

1.

**SPECIFICATIONS**

**XB-2**

<b>KEYBOARD</b>	C1 to C6	61Key		<b>MOD WHEEL</b>	
<b>DRAWBARS</b>	9 Pitch			<b>ORGAN SOLO</b>	MIDI OUT OFF
	B-TYPE		*	<b>POWER</b>	On/Off
	Mellow		*	<b>LESLIE</b>	Standard 11 Pin out
	Brite		*	<b>HEAD PHONE</b>	Stereo
	Slow Attack	On/Off	*	<b>SEND/RETURN</b>	For external Leslie Only
	Sustain	On/Off	*	<b>LINE OUT</b>	L/R
	Fold Back	Adjustable	*	<b>FOOT SWITCH</b>	Programmable *
<b>PERCUSSION</b>	2nd			<b>LCD</b>	Contrast adjustable
	3rd			<b>EXPRESSION</b>	Internal/External *
	Decay	Fast/Slow	*	<b>MIDI</b>	In/Out/Thru
	Volume	Soft	*		Function Programmable *
	Velocity	On/Off	*	<b>OVER DRIVE</b>	
<b>VIBRATO</b>	On/Off		*	<b>TONE CONTROL</b>	Bass/Treble
	V1, V2, V3,		*	<b>DIMENSIONS</b>	Width: 45 3/4(in) 116cm
	C1, C2, C3		*		Height: 3 3/4(in) 10cm
	Speed Slow, Norm, Mid, Fast		*		Depth: 12 1/4(in) 31cm
<b>KEY CLICK</b>	Off, Soft, Norm.		*		Weight: 30lbs. 13.5kg
<b>OVER DRIVE</b>	On/Off		*	<b>ACCESSORIES</b>	Foot Switch, Case, Stand, Expression Pedal.
	Depth	MOD Wheel			
<b>TUNING</b>	1 Hz Steps		*		
	430-450		*		
<b>TRANSPOSE</b>	±6 Semitones		*		
<b>LCD DISPLAY</b>	16 Characters, 2 Lines				
<b>PRESETS</b>	Cancel, 1-8 memorized				
	Patch Library 128 Patches				
<b>LESLIE</b>	Slow/Fast				
<b>VELOCITY</b>	Keyboard (MIDI OUT) Off, 1, 2		*		
	Percussion On/Off		*		
<b>KEY SPLIT</b>	On/Off		*		
	Split point		*		
	split Drawbar Set		*		
<b>PITCH BENDER</b>	± 1-12 Semitones		*		

☆ Features accessed through LCD

**XB-2 LCD DISPLAY MAP**

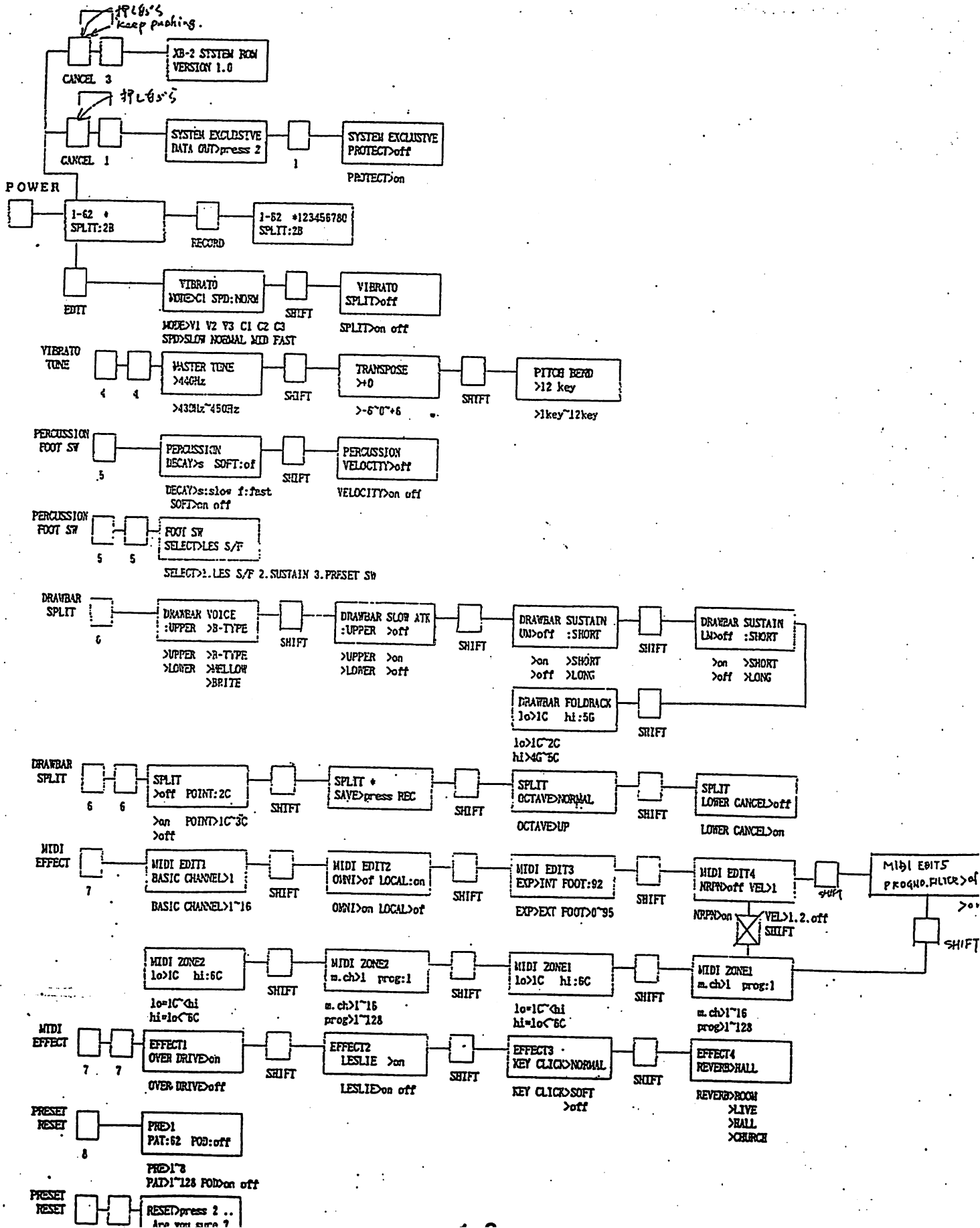

DIGITAL SECTION | ANALOG SECTION

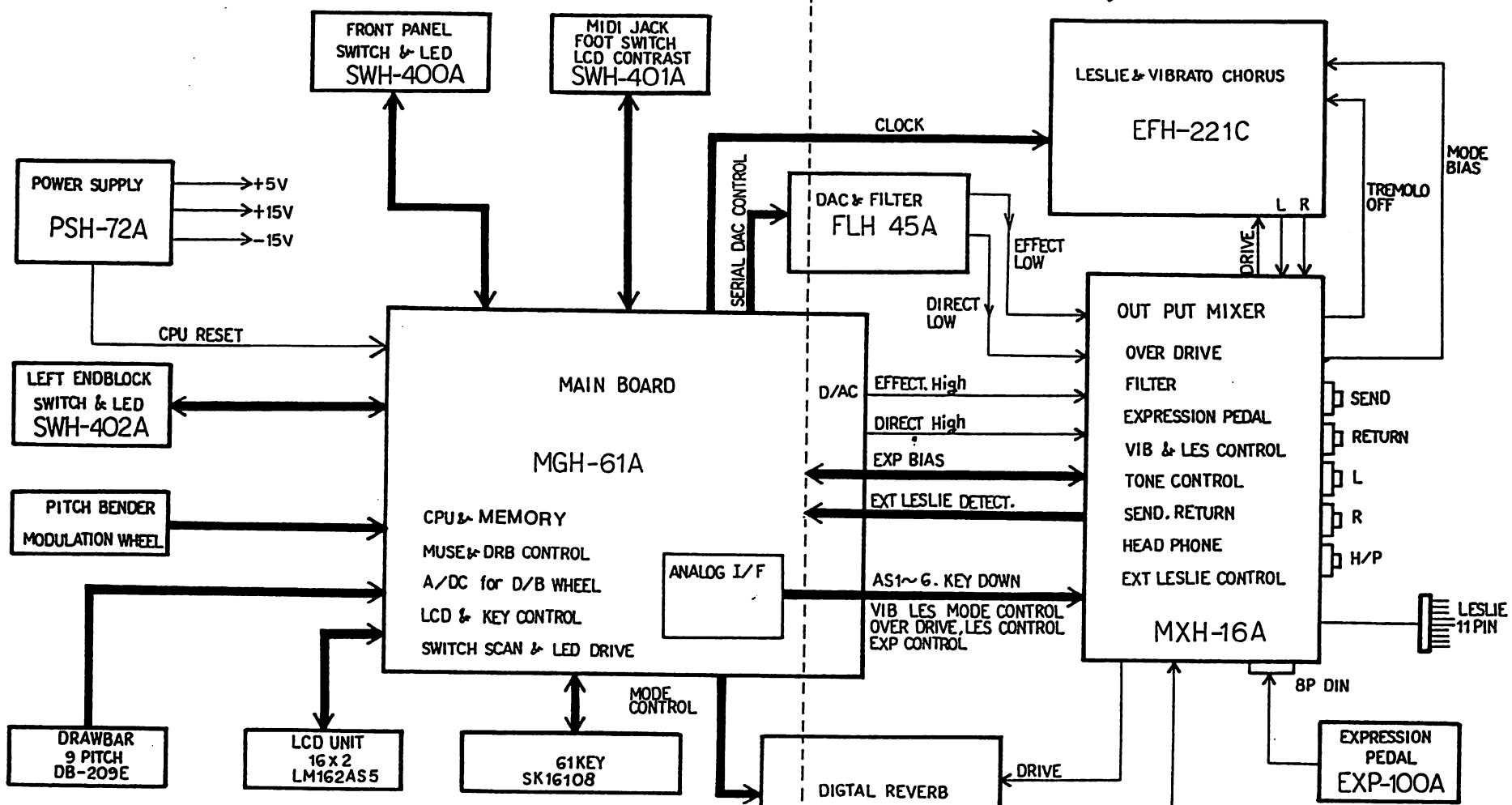

OUT PUT CHANNEL for Each Voice

VOICE	OUT PUT CHANNEL
PERCUSSION KEY CLICK	DIRECT High
B Type B Type (LES & VIB )	DIRECT High EFFECT High
MELLOW & BRITE	C1 ~ F4 DIRECT LOW
MELLOW & BRITE	F#4 ~ C6 DIRECT High
MELLOW & BRITE (LES & VIB)	C1 ~ F4 EFFECT LOW
	F#4 ~ C6 EFFECT High

2.

**XB-2**  
**BLOCK DIAGRAM**

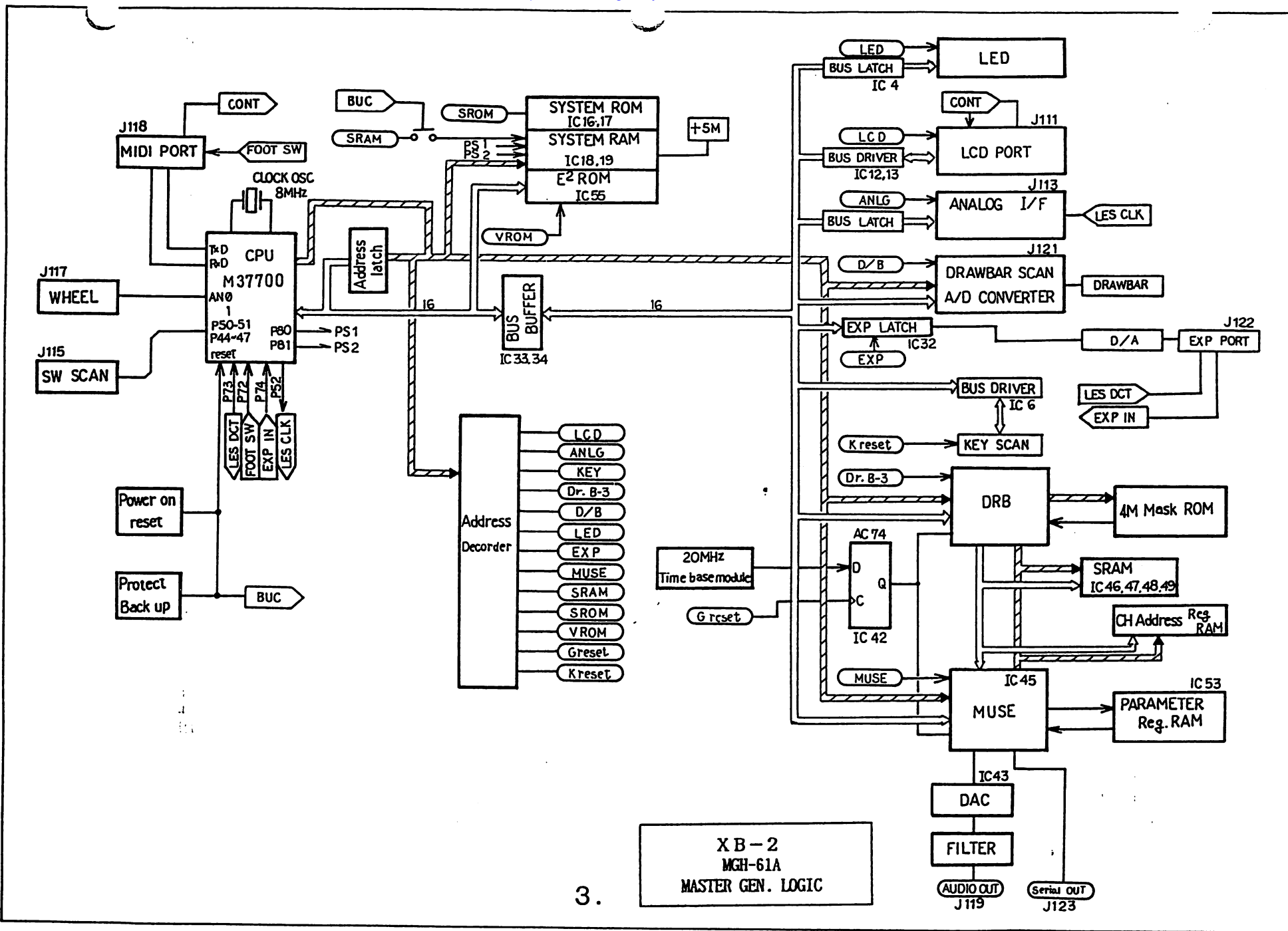

3.

X B - 2  
 MGH-61A  
 MASTER GEN. LOGIC

#### 4. DISASSEMBLY PROCEDURE

XB-2

CAUTION: DISCONNECT ORGAN FROM A. C. LINE  
VOLTAGE SOURCE.

(1) REMOVE TOP BOARD :

Loosen 5 screws of bottom board and remove the top board.

Note : Don't pull these screws excessively. Screws are  
not removed structurally.



(2) REMOVE KEYBOARD :

a) Follow steps(1) REMOVE TOP BOARD.

b) Remove 5 screws from the bottom.

c) Remove 3 screws on upperside.

d) At first, lift up the right side of keyboard. and then  
remove the keyboard.

[The left side of keyboard is under the endblock assembly.]

\* caution : wiring is connected.

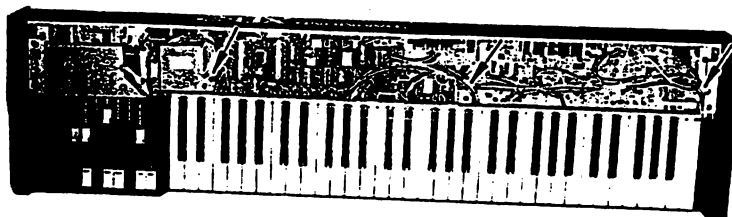



REMOVE ENDBLOCK :

- a) Follow steps (2) REMOVE THE KEYBOARD
  - b) Remove 2 screws from the bottom.
  - c) Remove 4 screws on the upperside.
  - d) and then remove the endblock assembly.
- ※ Caution : wirings are connected.

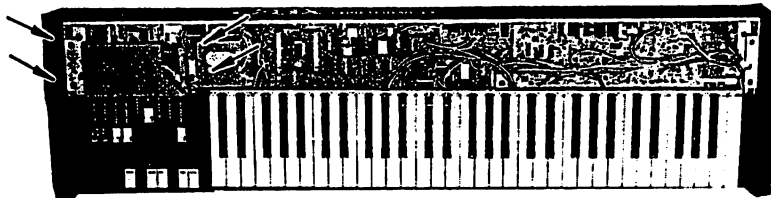
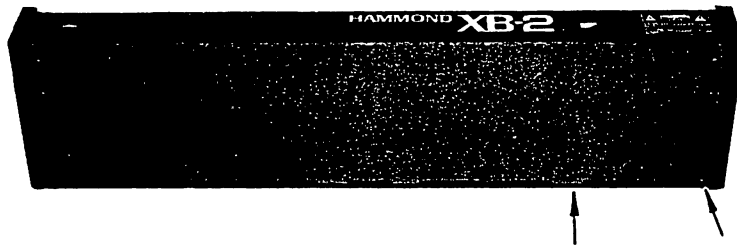

## 5. TEST AND ADJUSTMENT PROCEDURES

XB-2

NOTE-During the test procedure the following must be maintained unless otherwise stated:

- a. Expression pedal at maximum
- b. Drawbar type: Mellow
- c. All switches, Tonebars in the OFF position.
- d. Total volume at maximum

TEST STEP TEST	SETTING TAB & DRAWBAR	PLAY KEYS	ADJUST	TEST POINT	SPEC.
+5V			PSH-72A VR1	MGH-61A J110-①	DC+5.00V
EXPRESSION PEDAL	EXP. PEDAL MAX		MXH-16A R169	MXH-16A U7-⑥ (TP2)	DC-15mV
	EXP. PEDAL MIN		MXH-16A R29	↑	DC-170mV
OVER DRIVE WHEEL ADJUST	MODULATION MIN WHEEL		MXH-16A R177	MXH-16A U8-⑤ (TP1)	DC-60mV
	MODULATION MAX WHEEL		MXH-16A R176	↑	DC-3mV
E. LESLIE & VIBRATO	LESLIE ON		MXH-16A R180	MXH-16A J309-⑨	DC+12.0V
	VIBRATO ON MODE V2		MXH-16A R172	↑	DC+11.8V
	VIBRATO ON MODE V3		MXH-16A R179	↑	DC+10.4V
TOTAL VOLUME Lch	D/B 8' MAX LESLIE OFF TOTAL VOLUME MAX	A3	MXH-16A R46	LESLIE OUT "L" JACK or MXH-16A R11	220mV R.M.S
TOTAL VOLUME Rch	↑	↑	MXH-16A R43	LINE OUT "R" JACK or MXH-16A R10	220mV R.M.S
OVER DRIVE GAIN L	D/B 8' MAX LESLIE OFF TOTAL VOLUME MAX OVER DRIVE ON MOD. WHEEL MIN	↑	MXH-16A R76	LINE OUT "L" JACK or MXH-16A R11	220mV R.M.S
OVER DRIVE GAIN R	↑	↑	MXH-16A R178	LINE OUT "R" JACK or MXH-16A R10	220mV R.M.S
NOISE LEVEL L	ALL OFF TOTAL VR MAX	ANY KEY ON		LINE OUT "L" JACK or MXH-16A R11	0.5mV R.M.S WITH JIS "A" NET FILTER
		OFF		↑	0.05mV R.M.S    ↑
NOISE LEVEL R	↑	ANY KEY ON		LINE OUT "R" JACK or MXH-16A R10	0.5mV R.M.S    ↑
		OFF		↑	0.05mV R.M.S    ↑



### 8. WIRING CHART

XB-2

MAIN BOARD MGH-61A					
PLUG No.	FROM PIN.No.	TO PLUG & PIN.No.	WIRE COLOR	TO PWB NAME	FUNCTION
J110	1	J2-5	YEL	PSH-72A	+5V
	2	J112-1	YEL	MGH-61A	+5V
	3	NC			
	4	J2-3	BLK	PSH-72A	DG
	5	J112-3	BLK	MGH-61A	DG
J111	1	LCD-8	BLK	LCD UNIT	V <sub>SS</sub>
	2	-7	YEL		V <sub>OO</sub>
	3	-9	WHT		V <sub>O</sub>
	4	-6			RS
	5	-10			R/W
	6	-5			E
	7	-11			DB0
	8	-4			DB1
	9	-12			DB2
	10	-3			DB3
	11	-13			DB4
	12	-2			DB5
	13	-14			DB6
	14	-1			DB7
J112	1	J110-2	YEL	MGH-61A	+5V
	2	NC			
	3	J110-5	BLK	MGH-61A	D.GND
J113	1	J305-1	BRN	MXH-16A	KEY DOWN
	2	J307-8	RED	"	OVER DRIVE
	3	J305-3	ORG	"	LES S/F
	4	J305-5	YEL	"	LES ON
	5	J305-4	GRN	"	MIDI EXPON
	6	NC			
	7	J1302-2	WHT	EFH-221C	LES VIB
	8	NC			DG
J114	1	J16-1	YEL	61KEY	5V
	2	-2	BLK	SXPG	DG
	3	-3	BRN	143521	KRST
	4	-4	RED		KDB 6
	5	-5	ORG		5
	6	-6	YEL		4
	7	-7	GRN		3
	8	-8	BLU		2
	9	-9	VIO		1
	10	-10	GRY		0
	11	-11	WHT		STB
	12	-12	PNK		ACK
	13	-13	BRN		REQ
	14	NC			
	15	NC			

J115	1	J205-1	BRN	SWH-400A	S2
	2	-2	RED	"	S3
	3	-3	ORG	"	S4
	4	-4	YEL	"	S5
	5	-5	GRN	"	S6
	6	-6	BLU	"	S7
	7	-7	VIO	"	S1
	8	-8	GRY	"	S0
	9	-9	WHT	"	5V
	10	-10	PNK	"	LED COM
J116	1	J202-1	BRN	SWH-402A	LED1
	2	J202-2	RED	"	LED2
	3	J202-5	ORG	"	LED3
	4	J202-6	YEL	"	LED4
	5	J202-8	GRN	"	LED5
	6	NC			
	7	NC			
	8	NC			
	9	J202-3	BLU	SWH-402A	+5V
J117	1		YEL	BENDER	+5V
	2		RED	"	PITCH
	3		WHT	"	MOD
	4		BLK	"	G
J118	1	J201-6	BRN	SWH-401A	OUT
	2	-2	BLK	"	G
	3	-4	RED	"	OUT
	4	-9	ORG	"	THRU
	5	-5	BLK	"	G
	6	-7	YEL	"	THRU
	7	-3	GRN	"	IN
	8	-8	BLK	"	G
	9	-1	BLU	"	IN
	10	-10	VIO	"	CONT
	11	-11	GRY	"	+5V
	12	-12	WHT	"	FOOT SW
J119	1	NC			AG
	2	J302-4	WHT	MXH-16A	EFFECT
	3	J302-2	BLK	MXH-16A	AG
	4	J302-1	RED	MXH-16A	DIRECT IN
J120	1	J1-1	ORG	PSH-72A	+15V
	2	J132-6	ORG	FLH-45A	+15V
	3	J1-7	BLK	PSH-72A	AG
	4	J132-4	BLK	FLH-45A	AG
	5	J1-5	GRN	PSH-72A	-15V
	6	J132-2	GRN	FLH-45A	-15V
	7	J2-1	PNK	PSH-72A	RESET

MAIN BOARD MGH-61A					
PLUG No.	FROM PIN.No.	TO PLUG & PIN.No.	WIRE COLOR	TO PWB NAME	FUNCTION
J121	1	DRAWBAR		DRAWBAR	GND
	2				4'
	3				2'
	4				1'
	5				1 3/5'
	6				8'
	7				16'
	8				1 1/3'
	9				2 2/3'
	10				5 1/3'
	11				+5V
	12				
J122	1	J303-3	BRN	WXH-16A	MOD
	2	NC			AG
	3	NC			AG
	4	J303-4	YEL	WXH-16A	EXP OUT
	5	J303-5	GRN	WXH-16A	LES DCT
	6	NC			
	7	J303-7	VIO	WXH-16A	EXP IN
J123	1	J131-6	VIO	FLH-45A	BCLK
	2	J131-3	BRN	FLH-45A	LRCLK
	3	J131-4	RED	FLH-45A	WCLK
	4	J131-5	BLU	FLH-45A	DOUT2
	5	NC			DOUT1
	6	J131-7	YEL	FLH-45A	5V
	7	J131-8	BLK	FLH-45A	DG
J124	1	J309-1	BRN	MXH-16A	S1
	2	J309-2	RED		S2
	3	-3	ORG		S3
	4	-4	YEL		S4
	5	-5	GRN		S5
	6	J307-6	BLU		S6
	7	J1504-1	VIO	EFH-227A	DSP1
	8	J1504-2	GRY	EFH-227A	DSP2
	9	NC			DSPR
	10	NC			DSPW
	11	NC			DRESET
	12	NC			DG

LINE FILTER BOARD SWK-290C					
J2	1				BRN
	2				NC
	3				
	4				
	5				NC
	6				
	7				
	8				NC
	9				
POWER SUPPLY BOARD PSH-72A					
J1	1	J120-1	ORG	MGH-61A	+15V
	2	J1503-1	ORG	EFH-227A	+15V
	3	J301-8	WHT	WXH-16A	RELAY
	4	J301-7	BLK	WXH-16A	RELAY G
	5	J120-5	GRN	MGH-61A	-15V
	6	J1503-3	GRN	EFH-227A	-15V
	7	J120-3	BLK	MGH-61A	AG
	8	J1503-2	BLK	EFH-227A	AG
J2	1	J120-7	PNK	MGH-61A	RESET
	2	J1503-4	BLK	EFH-227A	DG
	3	J110-4	BLK	MGH-61A	DG
	4	J1503-5	YEL	EFH-227A	+5V
	5	J110-1	YEL	MGH-61A	+5V
J4	1				RED
	2				BLK
	3				RED
	4				NC
	5				YEL
	6				NC
	7				YEL
LEFT PANEL SW BOARD SWH-402A					
J202	1	J116-1	BRN	MGH-61A	LED1
	2	-2	RED		LED2
	3	-9	BLU		+5V
	4	NC			LED6
	5	J116-3	ORG		3
	6	-4	YEL		4
	7	NC			7
	8	J116-5	GRN		5
J203	1	J204-1	BRN	SWH-400A	S4
	2	-2	RED		S5
	3	-3	ORG		S6
	4	-6	BLU		S7
	5	-6	GRN		S1
	6	-4	YEL		S0

DAC & FILTER BOARD FLH-45A					
PLUG No.	FROM PIN.No.	TO PLUG & PIN.No.	WIRE COLOR	TO PWB NAME	FUNCTION
J131	1	NC			DG
	2	NC			DG
	3	J123-2	BRN	MGH-61A	LRCLK
	4	-3	RED		WCLK
	5	-4	BLU		DOUT2
	6	-1	VIO		BCLK
	7	-6	YEL		5V
	8	-7	BLK	↓	DG
J132	1	J301-5	GRN	MXH-16A	-15V
	2	J120-6	GRN	MGH-61A	-15V
	3	J301-3	BLK	MXH-16A	AG
	4	J120-4	BLK	MGH-61A	AG
	5	J301-1	ORG	MXH-16A	+15V
	6	J120-2	ORG	MGH-61A	+15V
J133	1	J310-1	RED	MXH-16A	EFFECT2
	2	J310-2	GND	MXH-16A	AD
	3	J310-3	WHT	MXH-16A	DIRECT2
MIXER BOARD MXH-16A					
J301	1	J132-5	ORG	FLH-45A	+15V
	2	J1303-1	ORG	EFH-221C	+15V
	3	J132-3	BLK	FLH-45A	AG
	4	J1303-3	BLK	EFH-221C	AG
	5	J132-1	GRN	FLH-45A	-15V
	6	J1303-5	GRN	EFH-221C	-15V
	7	J1-4	BLK	PSH-72A	RELAY G
	8	J1-3	WHT	PSH-72A	RELAY
J302	1	J119-4	RED	MGH-61A	DIRECT IN
	2	J119-3	BLK	MGH-61A	AG
	3	NC			AG
	4	J119-2	BRN	MGH-61A	EFFECT IN
J303	1	NC			AG
	2	NC			AG
	3	J122-1	BRN	MGH-61A	MOD
	4	-4	YEL	MGH-61A	EXP OUT
	5	-5	GRN	MGH-61A	LES DCT
	6	NC			
	7	J122-7	VIO	MGH-61A	EXP IN
J304	1	①	BRN	11PIN	
	2	②	RED		
	3	③	ORG		
	4	④	BLK		
	5	⑤	BLK		
	6	⑥	BLU		

J304	7	⑤	VIO	11PIN	
	8	⑥	GRY		
	9	⑦	WHT		
	10	NC	PNK		
	11	⑧		↓	
J305	1	J113-1	BRN	MGH-61A	KEY DOWN
	2	NC			
	3	J113-3	ORG	MGH-61A	LES S/F
	4	J113-5	GRN	MGH-61A	MIDI EXPON
	5	J113-4	YEL	MGH-61A	LES ON
	6	NC			AG
J306	1		BLK	TOTAL VR	GND
	2		BLK		GND
	3		RED		R IN
	4		RED		L IN
	5		WHT		R OUT
	6		WHT		L OUT
J307	1	J1301-2	BRN	EFH-221C	T.B.SIG IN
	2	-5	RED	EFH-221C	MAIN Lch
	3	-8	BLK	EFH-221C	AG
	4	NC			AG
	5	J1301-6	GRN	EFH-221C	SUB Lch
	6	J124-6	BLU	MGH-61A	S6
	7	J309-6	PNK	MXH-16A	S5 (MX)
	8	J113-2	RED	MGH-61A	OVER DRIVE
J308	1	J1501-6	RED	EFH-227A	REV OUT
	2		BLK	REVERB-	GND
	3	NC	WHT	VR	GND
	4				L IN
	5		RED	EFH-227A	
J309	1	J124-1	BRN	MGH-61A	S1
	2	-2	RED		S2
	3	-3	ORG		S3
	4	-4	YEL		S4
	5	-5	GRN		S5
	6	J307-7	PNK	MXH-16A	S5 (MX)
	7	NC			AG
	8	J1302-1	GRY	EFH-221C	DEPTH ON
	9	J1302-4	WHT	EFH-221C	BIAS
J310	1	J133-1	RED	FLH-45A	EFFECT 2
	2	J133-2	GND	FLH-45A	AD
	3	J133-3	WHT	FLH-45A	DIRECT 2

LESLIE & VIB BOARD EFH-221C					
PLUG No.	FROM PIN.No.	TO PLUG & PIN.No.	WIRE COLOR	TO PWB NAME	FUNCTION
J 1301	6	J307-5	GRN	MXH-16A	SUB Lch
	7	NC			SUB Rch
	8	J307-3	BLK	MXH-16A	AG
J 1302	1	J309-8	GRY	MXH-16A	DEPTH ON
	2	J113-7	WHT	MXH-16A	LES VIB
	3				AG
	4	J309-9	WHT	MXH-16A	BIAS
J 1303	1	J301-2	ORG	MXH-16A	+15V
	2	NC			+15V
	3	J301-4	BLK	MXH-16A	AG
	4	NC			AG
	5	J301-6	GRN	MXH-16A	-15V
	6	NC			-15V
DIGITAL REVERB BOARD EFH-227A					
J 1501	1	NC		TOTAL VR	SIG OUT
	2		RED	REVERB	
	3	NC		VR	SIG OUT
	4		WHT		
	5	NC			SIG IN
	6	J308-1	RED	MXH-16A	
	7	NC			
	8	NC			
J 1503	1	J1-2	ORG	PSH-72A	+15V
	2	J1-8	BLK		AG
	3	J1-6	GRN		-15V
	4	J2-2	BLK		DG
	5	J2-4	YEL		+5V
J 1504	1	J124-7	VIO	MGH-61A	DSP 1
	2	J124-8	GRY	MGH-61A	DSP 2
	3	NC			
LCD					
	1	J111-14	WHT	MGH-61A	Vss
	2	-12	WHT		Vdd
	3	-10	WHT		Vo
	4	-8	WHT		RS
	5	-6	WHT		R/W
	6	-4	WHT		E
	7	-2	BLK		DB0
	8	-1	WHT		DB1
	9	-3	WHT		DB2
	10	-5	WHT		DB3

	1 1	J111-7	WHT	MGH-61A	DB4
	1 2	-9	WHT	"	DB5
	1 3	-11	WHT	"	DB6
	1 4	-13	WHT	"	DB7
MIDI JACK BOARD SWH-401A					
J201	1	J118-9	BLU	MGH-61A	IN
	2	-2	BLK		IN
	3	-7	GRN		IN
	4	-3	RED		OUT
	5	-5	BLK		OUT
	6	-1	BRN		OUT
	7	-6	YEL		THRU
	8	-8	BLK		THRU
	9	-4	ORG		THRU
	10	-10	VIO		CONT
	11	-11	GRY		+5V
	12	-12	WHT		FOOT SW
PRESET SW BOARD SWH-400A					
J204	1	J203-1	BRN	SWH-402A	S4
	2	-2	RED		S5
	3	-3	ORG		S6
	4	-6	YEL		S0
	5	-5	GRN		S1
	6	-4	BLU		S7
J205	1	J115-1	BRN	MGH-61A	S2
	2	-2	RED		S3
	3	-3	ORG		S4
	4	-4	YEL		S5
	5	-5	GRN		S6
	6	-6	BLU		S7
	7	-7	VIO		S1
	8	-8	GRY		S0
	9	-9	WHT		5V
	10	-10	PNK		LED COM

## PRINTED WIRING BOARD ASS'Y LIST

XB-2

MAIN	MGH-61A	228-22206
LINE FILTER	SWK-290C	225-28218
POWER SUPPLY	PSH-72A	224-18206
PRESET SWITCH	SWH-400A	225-34206
MIDI JACK	SWH-401A	225-34216
LEFT PANEL SWITCH	SWH-402A	225-34216
DAC & FILTER	FLH-45A	222-17241
MIXER	MXH-16A	230-06201
DIGITAL REVERB	EFH-227A	223-41226
LESLIE & VIBRATO	EFH-221C	223-40288

XB-2N (WITHOUT DIGITAL REVERB)

MAIN BOARD IS MGH-61AN 228-22206N

(which is same as MGH-61A except adding JP4 to MGH-61A)



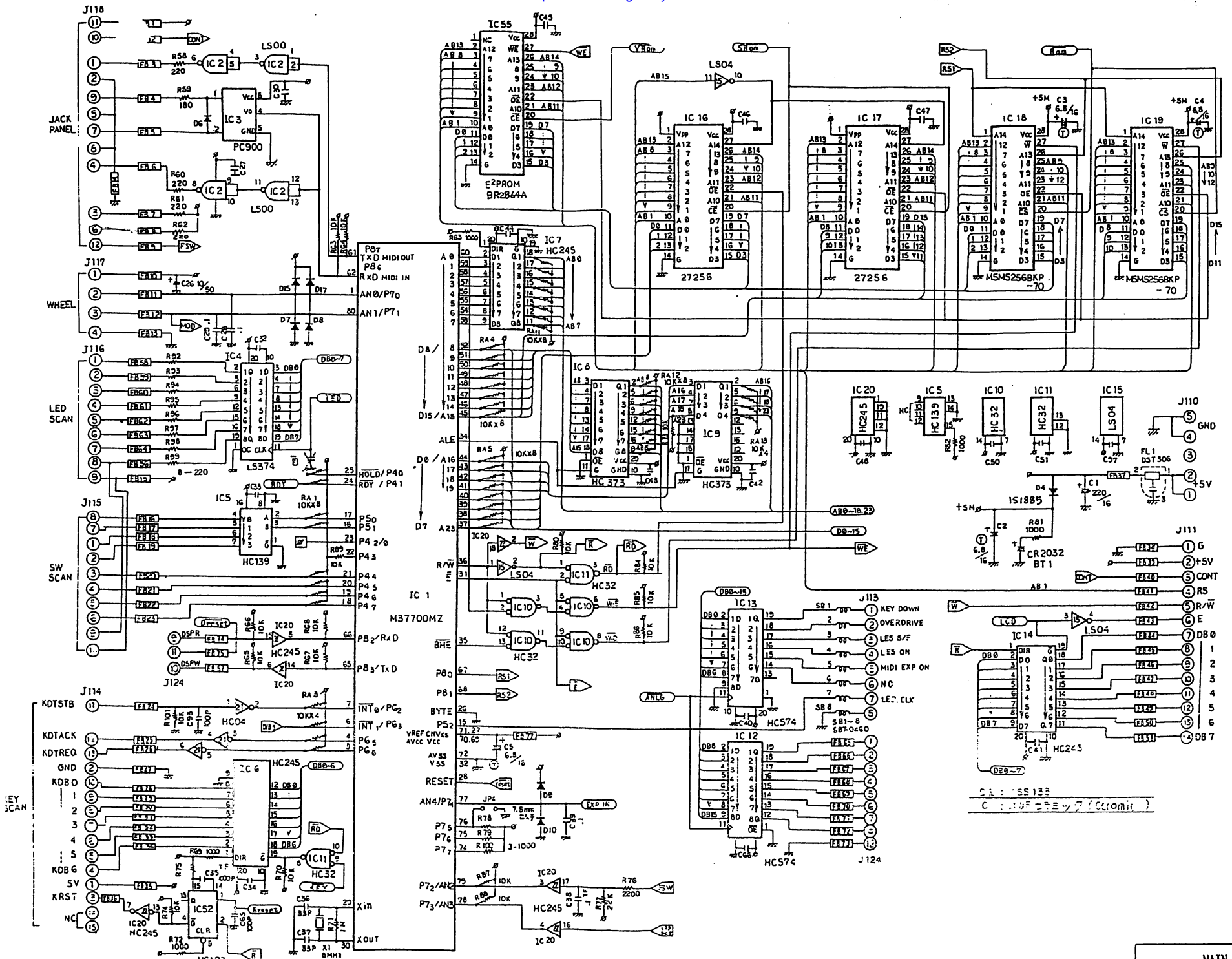

XB-2



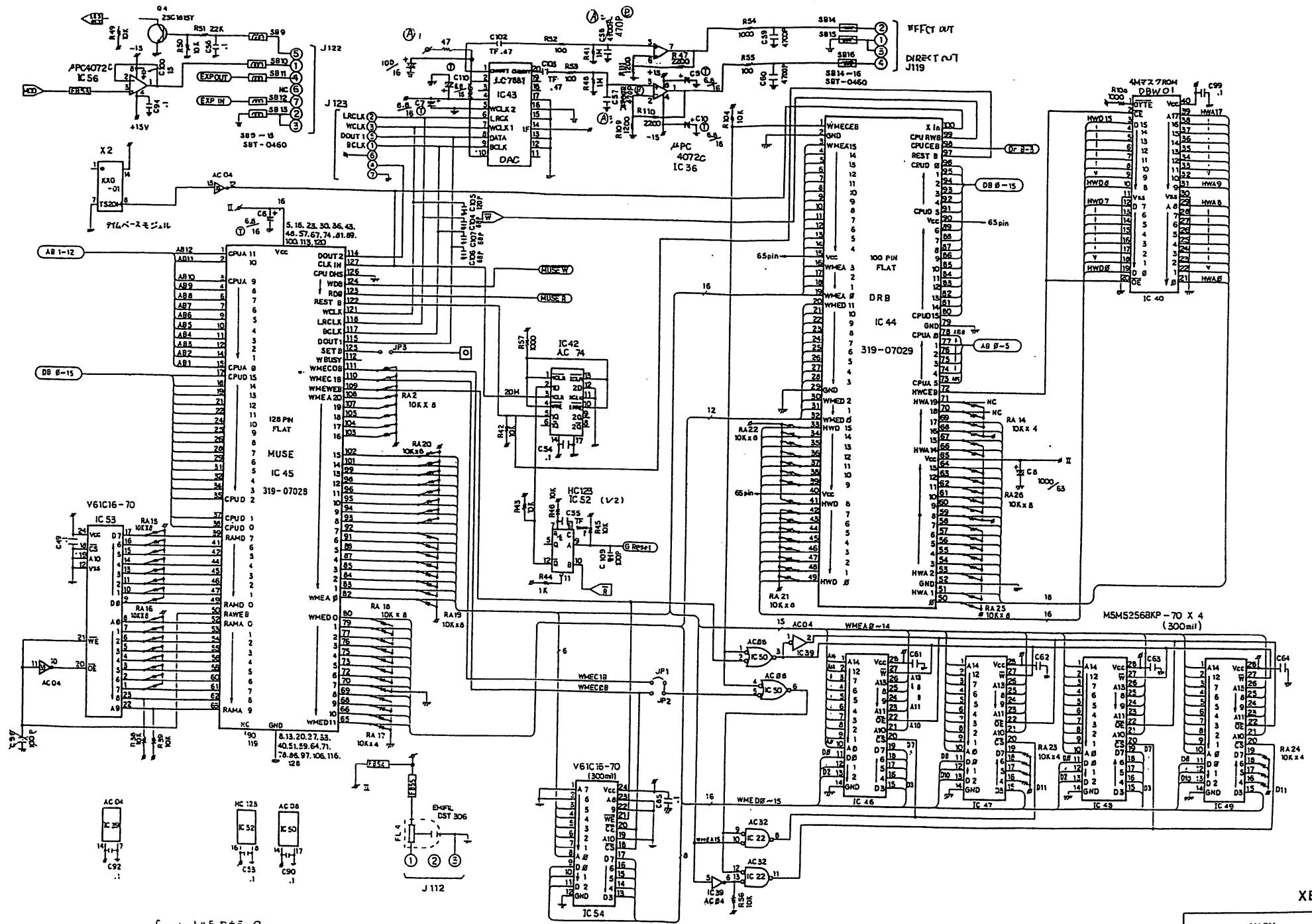

C : .1μF エラミツク  
 ⊕ : TANTALUM

XB-2

MAIN  
 MGH-61A 3/3  
 228-22206

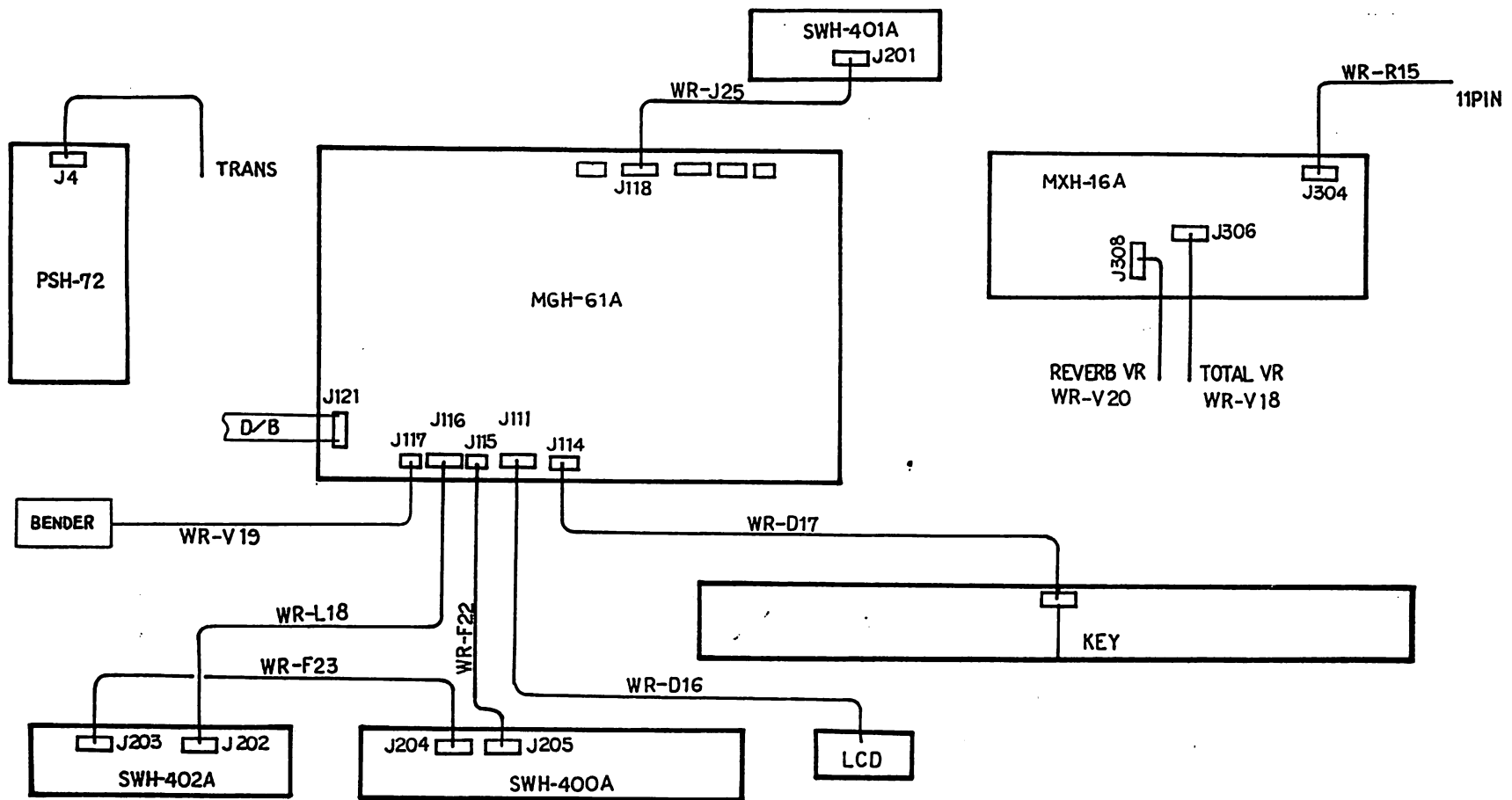

XB-2

7. SUB WIRING CHART  
105-17430

- C1 DE7150 FZ 103VA1 MURATA
- C2) DE7120 F332HVA1 MURATA
- C3) DE7120 F332HVA1 MURATA
- L1 SC-02 -30G TOKIN

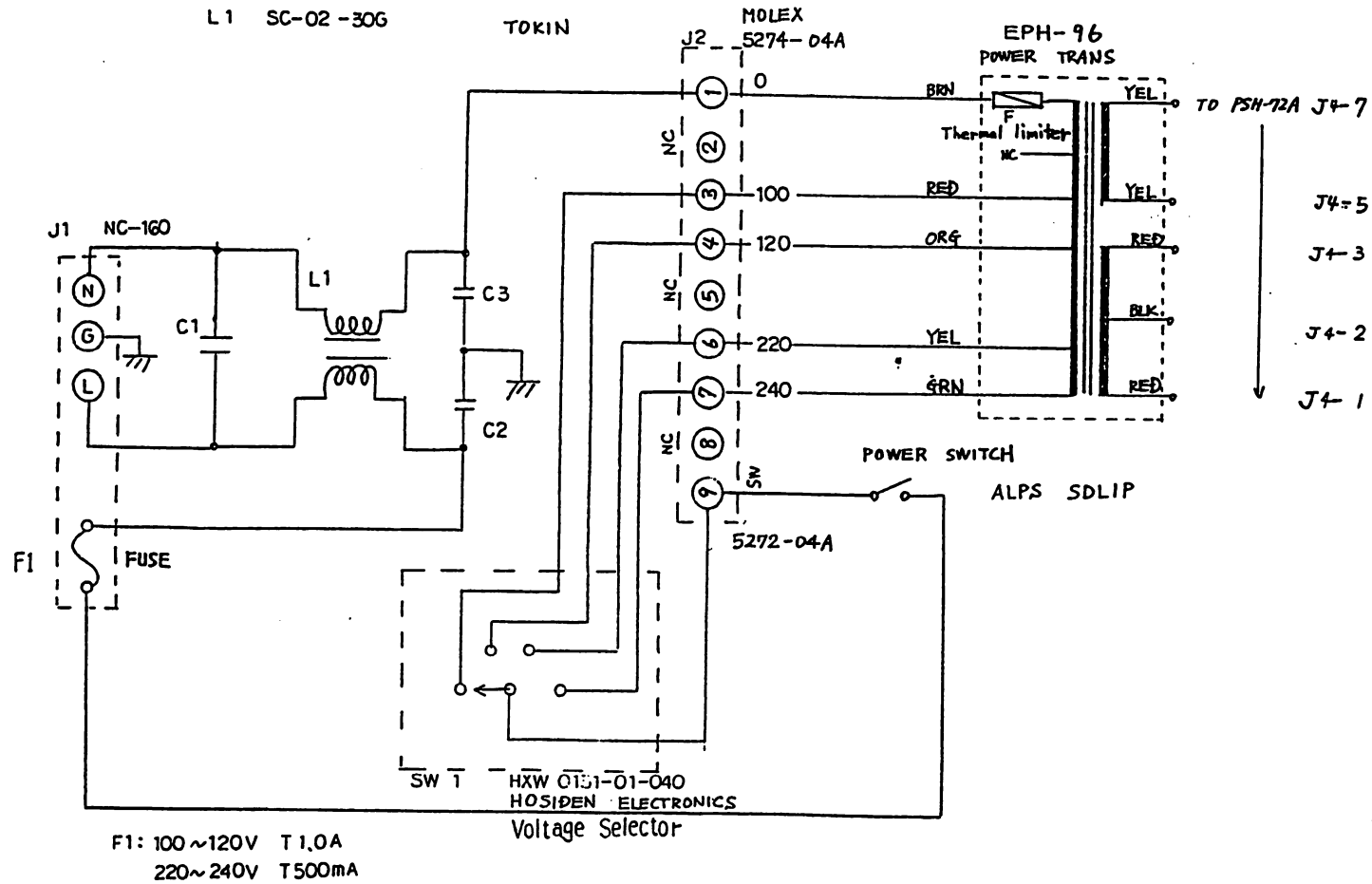

**XB-2**

**LINE FILTER  
 SWK-290C  
 225-28218**

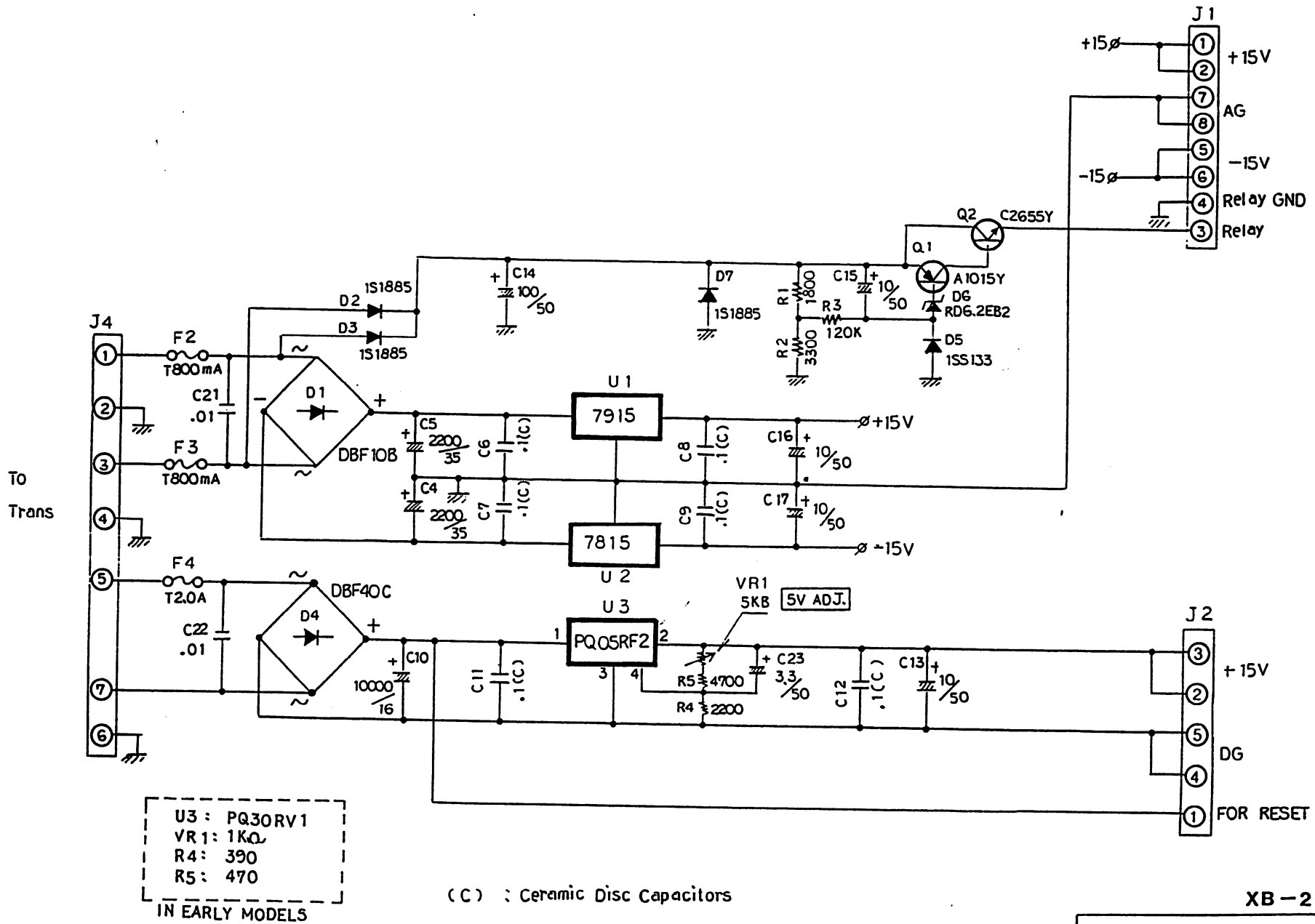

XB-2  
 POWER SUPPLY  
 PSH-72A  
 224-18206

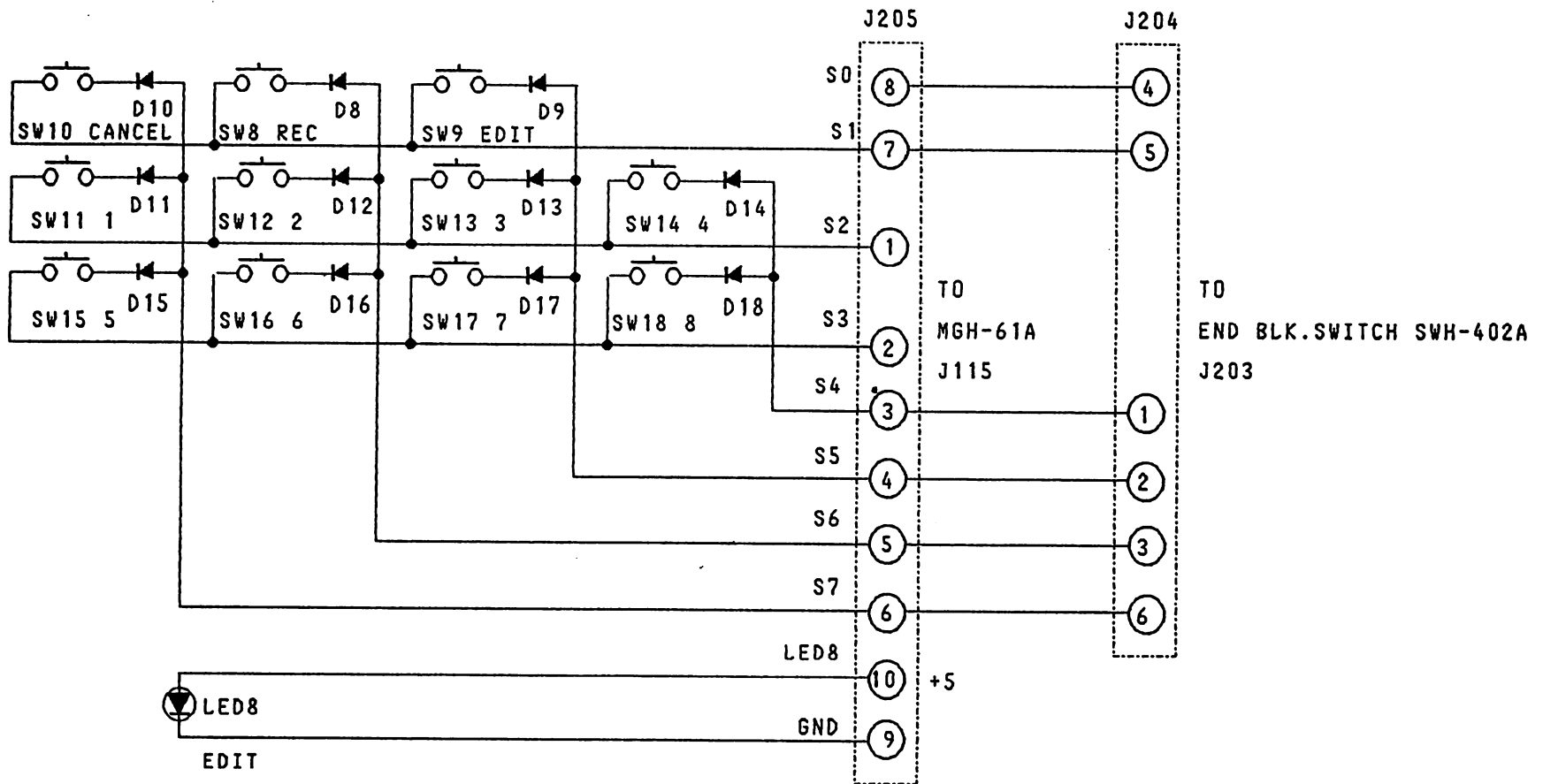

SW8~18 : TM1-01 FUJISOKU  
 D8 ~18 : 1SS133 ROHM  
 LED8 : GL3TR8 SHARP

XB-2

PRESET SWITCH  
 SWH-400A  
 225-34206

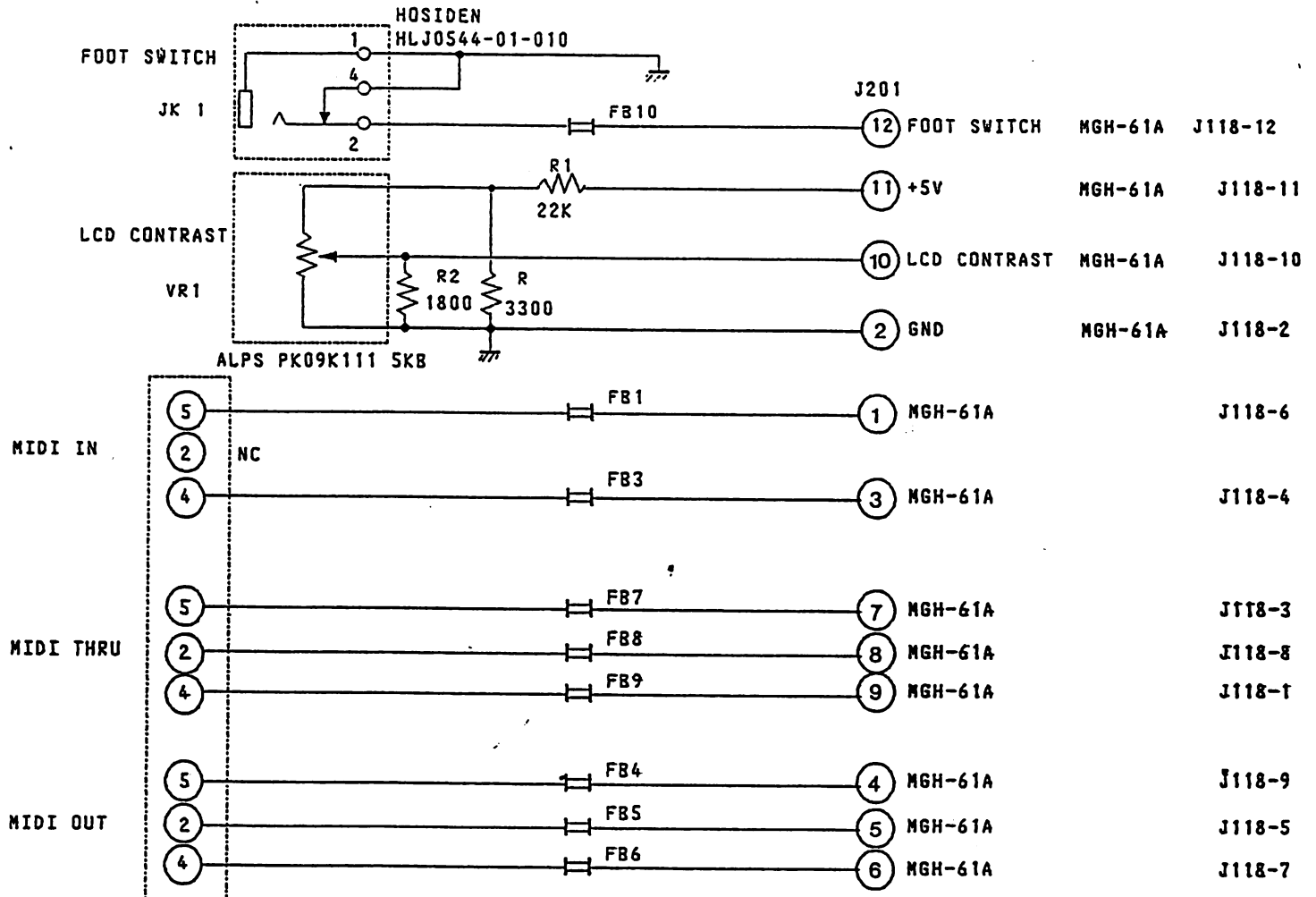

FB1-7, 9, 10: BL02RN2-A62

YKF51-5046 (318-04074)

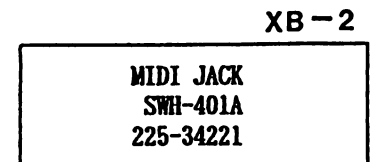
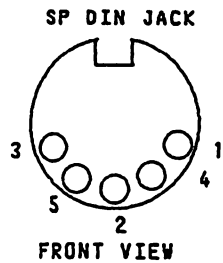



SW1~5 FM2-5 TOTSUKO  
 D1~5 1SS133 ROHM  
 LED1~5 GL3TR8 SHARP

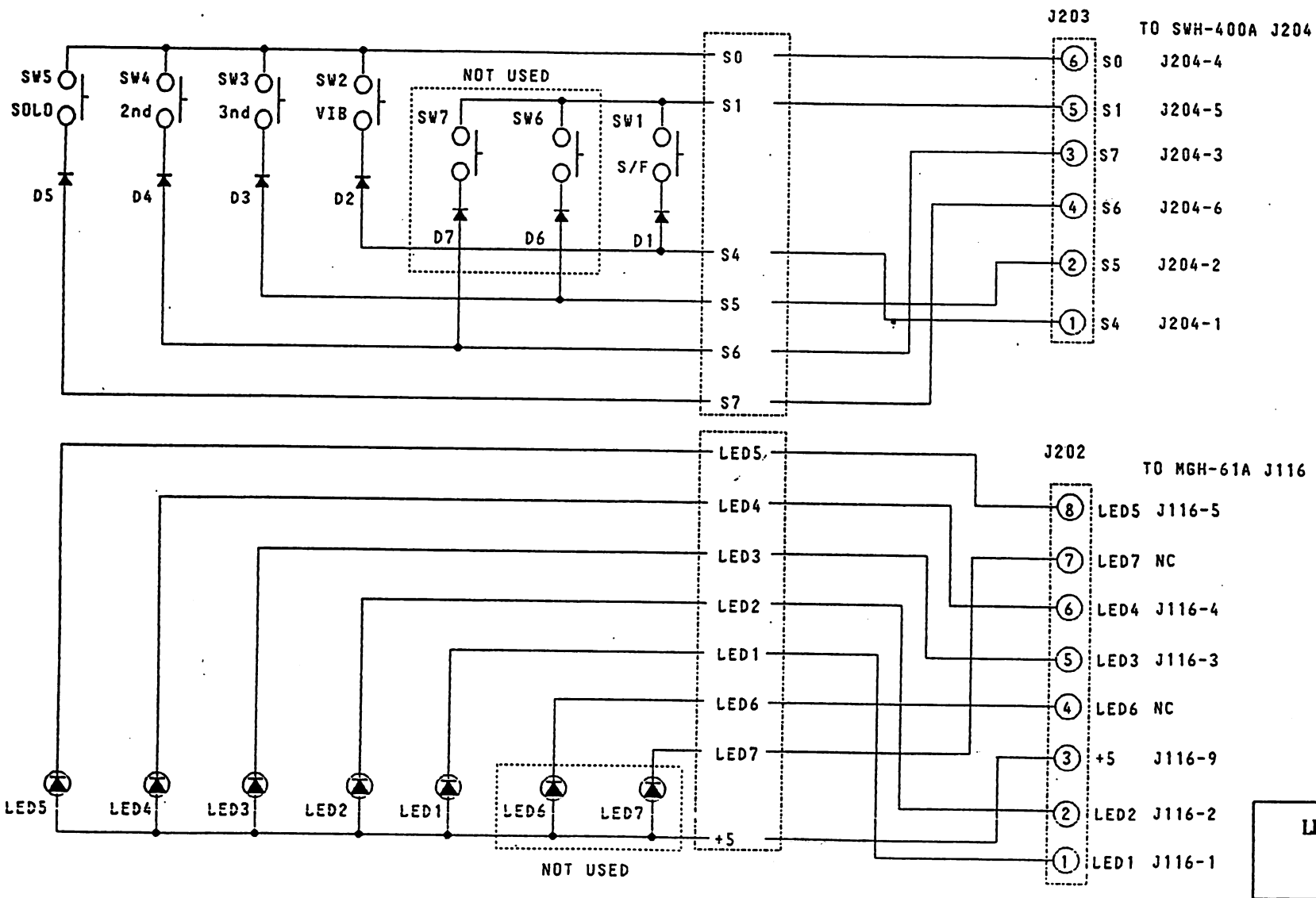

**XB-2**

**LEFT PANEL SWITCH**  
 SWH-402A  
 225-34216

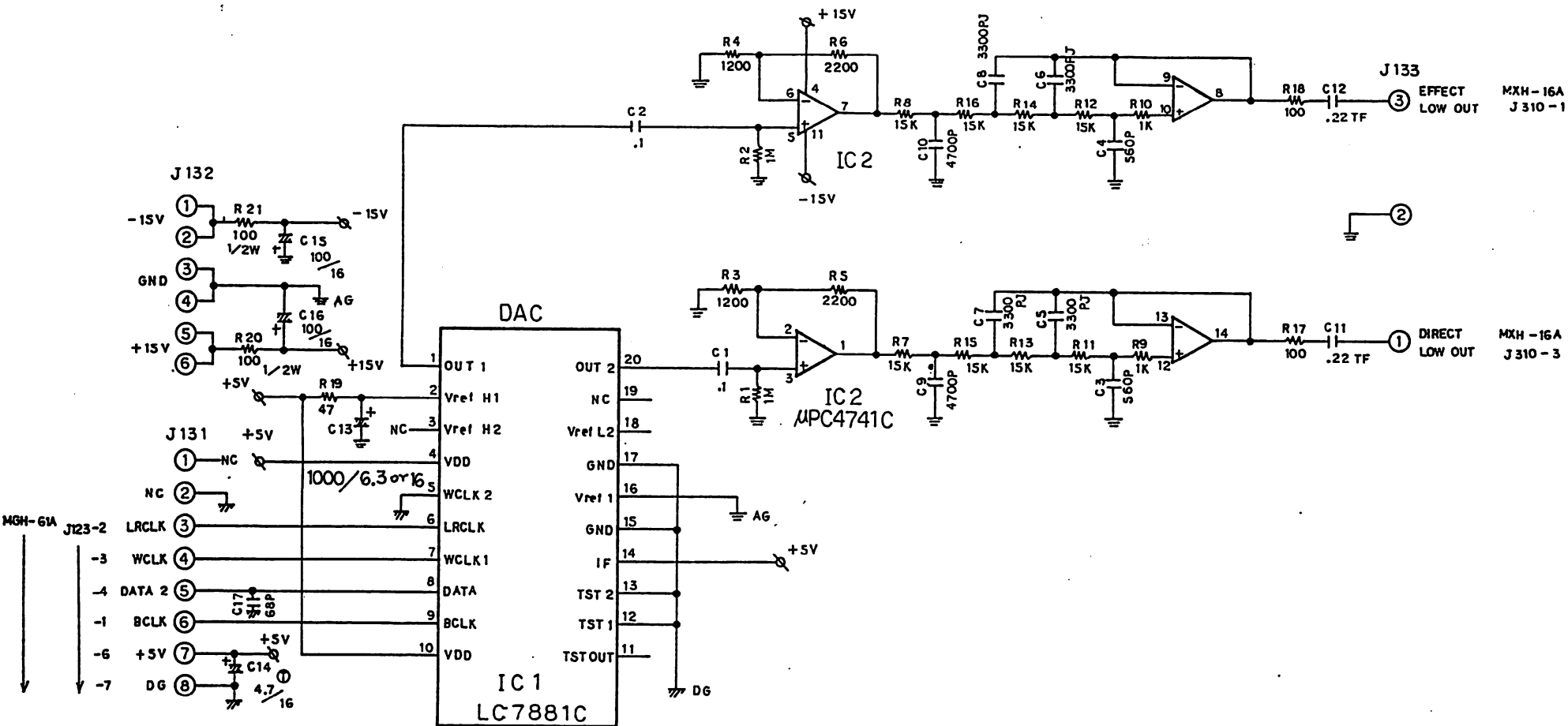

**XB-2**

**DAC & FILTER  
 FLH-45A  
 222-17241**

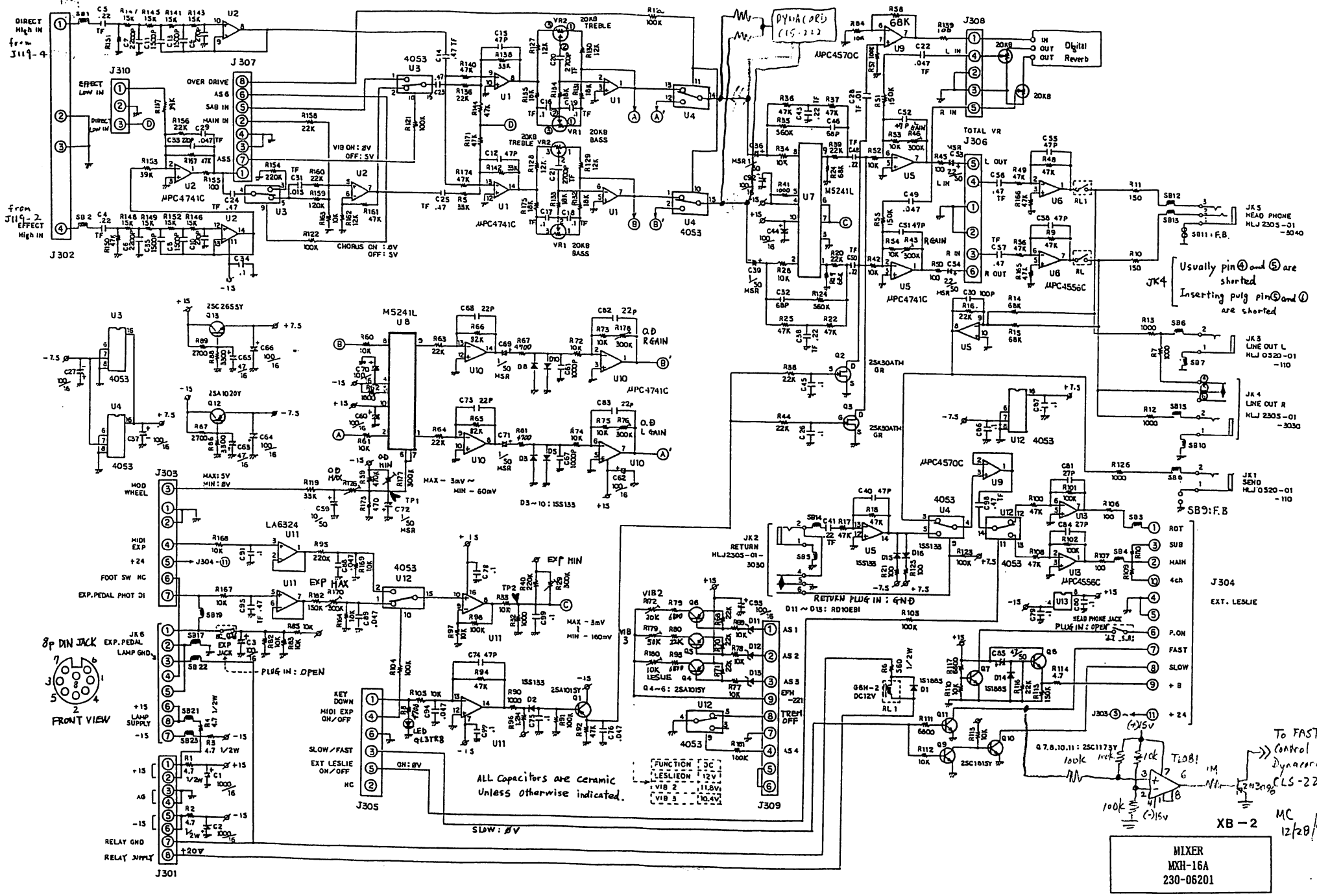

MIXER  
 MXH-16A  
 230-06201

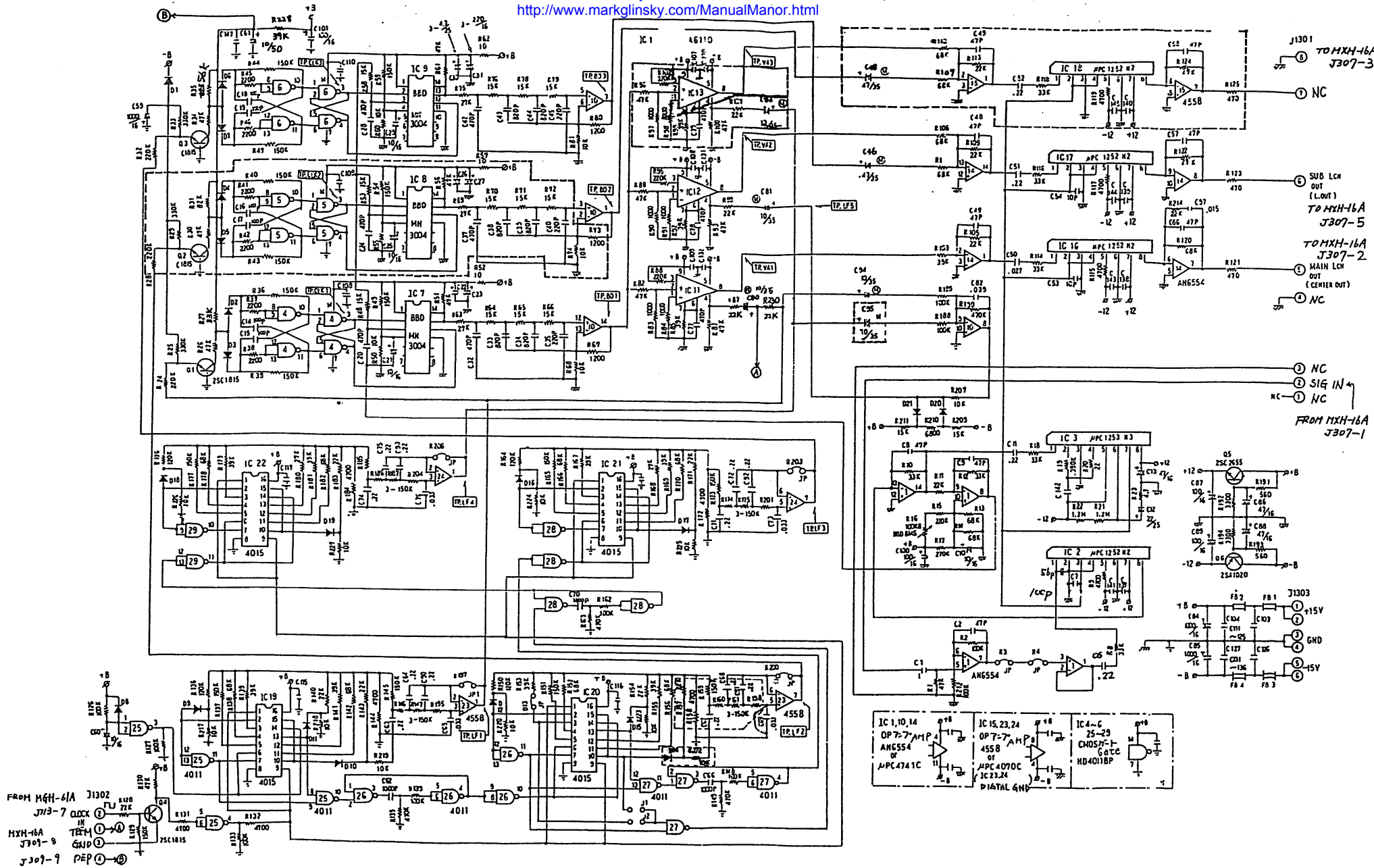

NOTE:

- D1~12, 14~21 ISS133
- FB1~4 Ferrite Beads
- T Tantalum
- M MSR Electrolytic Capacitors
- Ceramics .047  $\mu$ F/25V

NOT USED

XB - 2

LESLIE & VIBRATO  
 EFH-221C  
 223-40288

After 9106 xxxx ~

VR1: NOT USE  
 R15: NOT USE  
 R16: 11.5KΩ

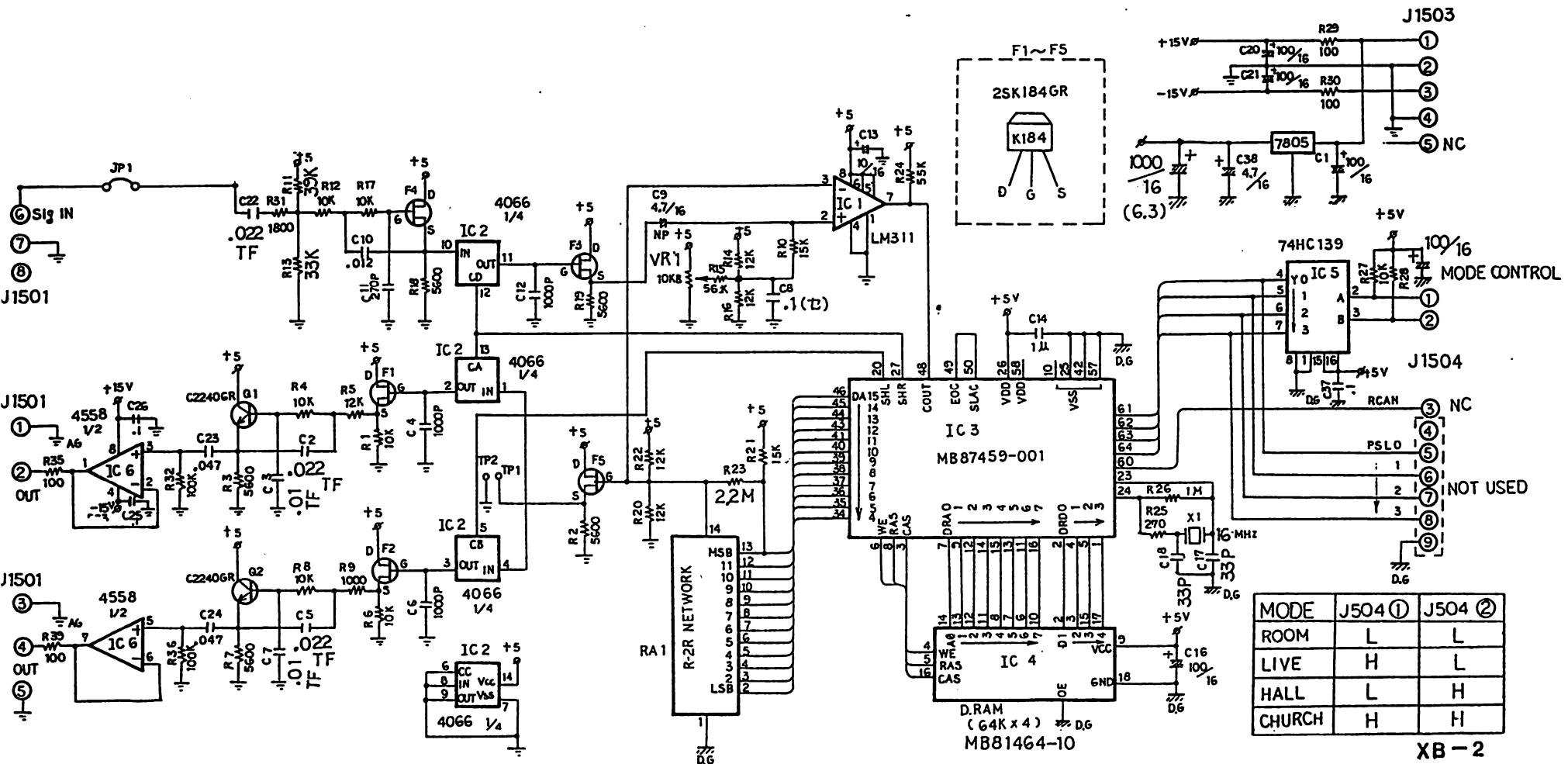

MODE	J504 ①	J504 ②
ROOM	L	L
LIVE	H	L
HALL	L	H
CHURCH	H	H

XB-2

DIGITAL REVERB  
 EFH-227A  
 223-41226

# SERVICE PARTS LIST

## XB-2

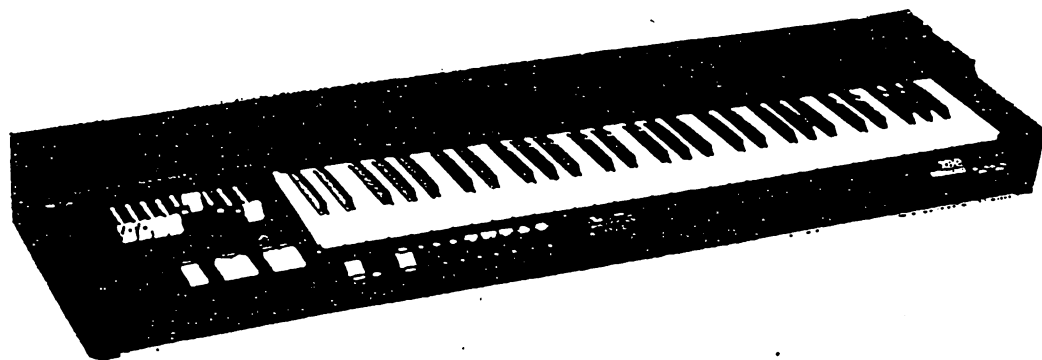

April , 1991

 HAMMOND SUZUKI LTD.

## SERVICE PARTS LIST

### PARTS ORDERING INFORMATION

When ordering replacement parts from the Hammond Suzuki Ltd., the following guidelines should be observed:

- 1) Address all part orders to:

HAMMOND SUZUKI LTD  
SERVICE DEPARTMENT  
25-12.Ryoke 2 chome.  
Hamamatsu430 (Shizuoka)  
Japan

TEL 053-462-7810  
FAX 053-462-7815

- 2) All orders should specify the model and serial number of the instrument that is being serviced. (Note: the model and serial number is printed on the nameplate attached to the underside of the organ keyboard.)
- 3) All orders should specify the Hammond part numbers of the desired parts.
- 4) All orders should provide specific descriptions of the desired parts. (For example: Power transformer, PWB-72A Ass'y, F through B Key mold, etc.)

---

### TABLE OF CONTENTS

	Page
1. TOTAL ASS'Y .....	3
2. PRINTED WIRING BOARD ASS'Y LIST .....	5
3. PWB ASS'Y LOCATION .....	5
4. KEYBOARD ASS'Y .....	6
5. FRONT PANEL ASS'Y .....	6
6. TOP BOARD ASS'Y .....	7
7. ENDBLOCK (L) ASS'Y .....	7
8. WHEEL ASS'Y .....	8
9. EXPRESSION PEDAL ASS'Y .....	9

1. TOTAL ASS'Y

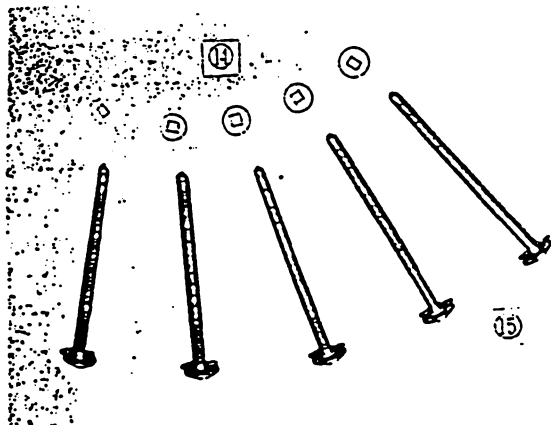
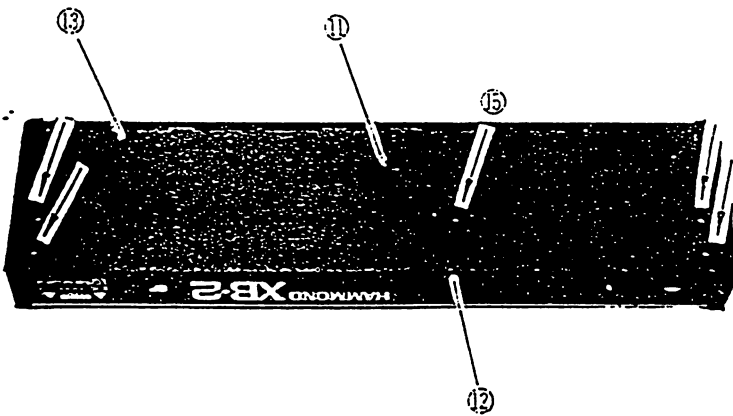
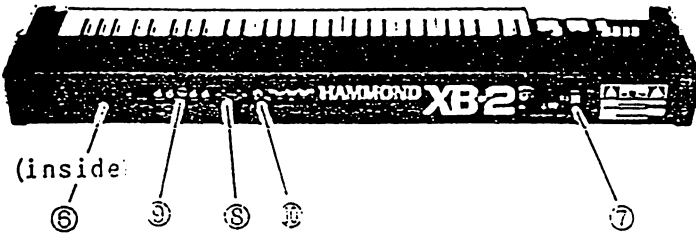
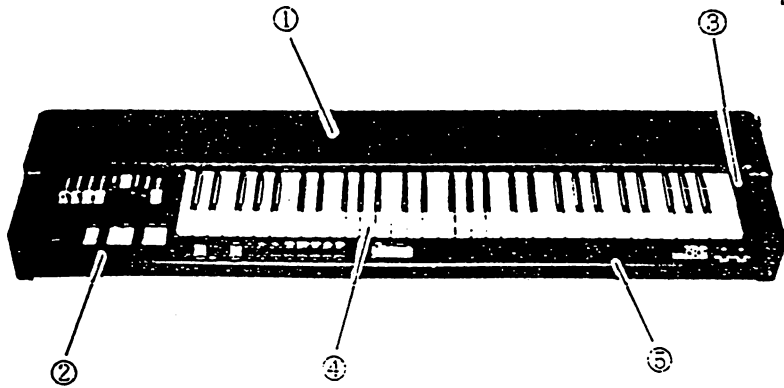

Ref.No.	Description	Part No.
①	Top Board Ass'y	105-17236
②	Endblock(L) Ass'y	105-17244
③	" (R)	402-01944
④	Keyboard Ass'y	105-17241
⑤	Front Panel Ass'y	105-17242
⑥	Jack Panel	401-13366
⑦	Switch Cap ES	M1332
⑧	Volume Knob TK1154 (Screw Lock type)	304-02120
⑨	Jack Nut(with Jack)	M12
⑩	" ( " )	M9
⑪	Bottom Board Ass'y	105-17232
⑫	Staple (W4 x L19)	
⑬	Rubber foot K12	402-05084
⑭	Washer TM-147 No.5566(M6)	
⑮	Joint Connector Bolt JCBB-0113M	

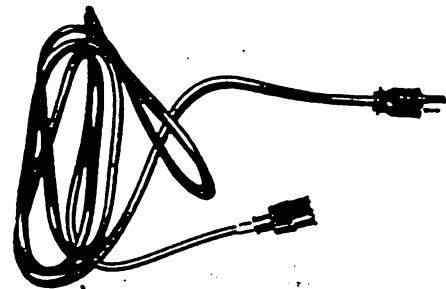

Power Supply Cord	
100V	439-02002
120V	439-01004
220V	439-01005
240V	439-01006



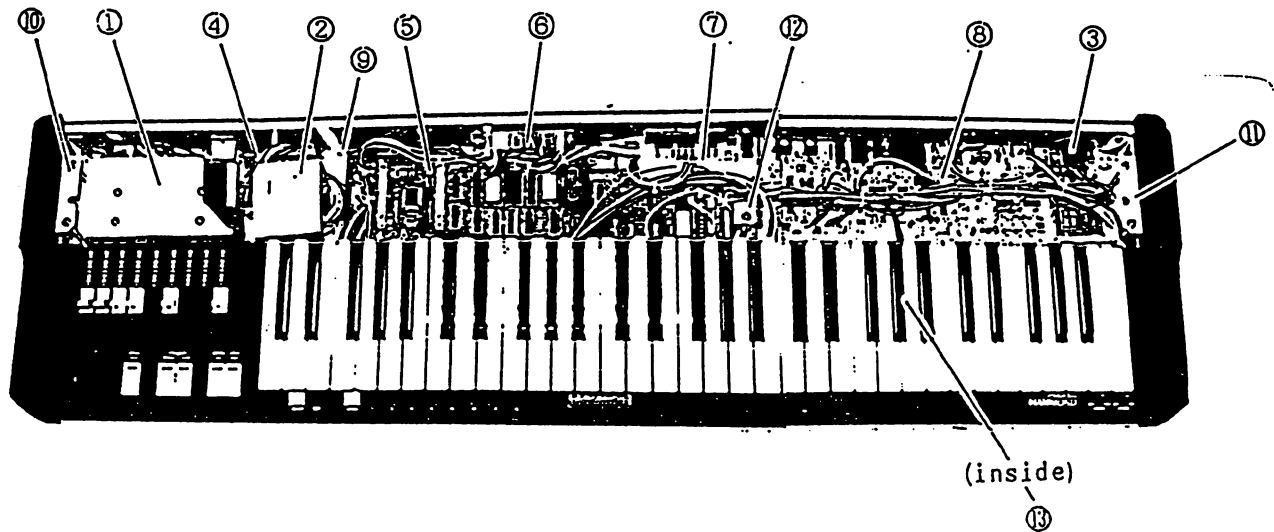

Ref No.	Description	Part No.
①	Drawbars Ass'y (DB-209E)	278-09206
②	Power Supply Trans. Ass'y EPH-96	105-17247
③	LESLIE 11-pin Connector SA-607B-00	317-09007
④	P. W. B. Ass'y SWK-290C	225-28218
⑤	" MGH-61A	228-22206
⑥	" FLH-45A	222-17241
⑦	" SWH-401A	225-34211
⑧	" MXH-16A	230-06201
⑨	Electric Conductive Tape	T-200.W-20mm
⑩	Top Board Bracket (L)	401-13376
⑪	" (R)	401-13377
⑫	" (C)	401-13378
⑬	Shield Cover XB-2	402-02229

2. PRINTED WIRING BOARD ASS'Y LIST

X B - 2		P. W. B
MAIN	MGH-61A	228-22206
AC INPUT	SWK-290C	225-28218
POWER SUPPLY	PSH-72A	224-18206
PRESET SW	SWH-400A	225-34206
MIDI JACK	SWH-401A	225-34211
SWITCH	SWH-402A	225-34216
DAC & FILTER	FLH-45A	222-17241
MIXER	MXH-16A	230-06201
D · REV	EFH-227A	223-41226
LESLIE	EFH-221C	223-40288

3. P.W.B ASS'Y LOCATION

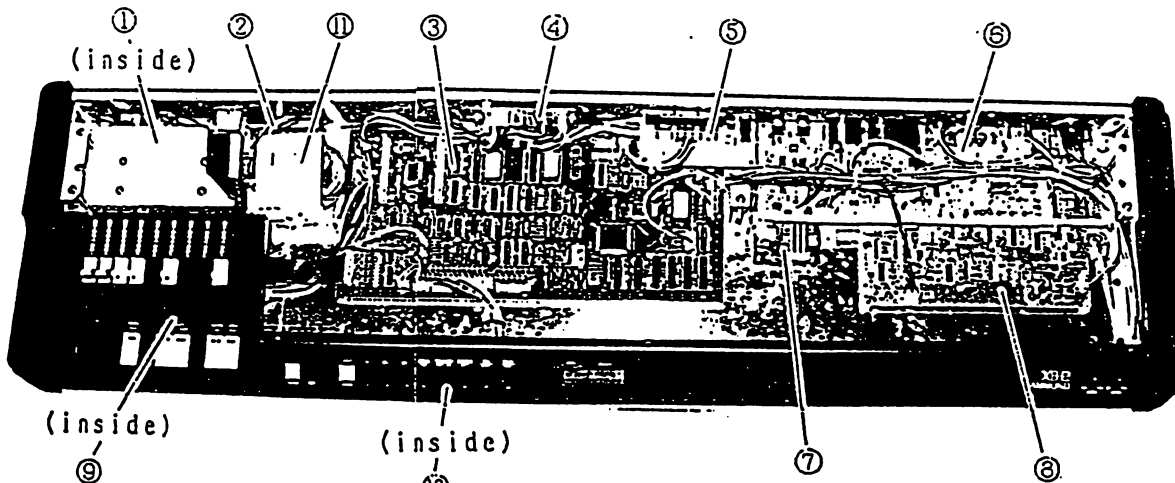

- ① PSH-72A  
(under the Drawbars Ass'y)
- ② SWK-290C
- ③ MGH-61A
- ④ FLH-45A
- ⑤ SWH-401A
- ⑥ MXH-16A
- ⑦ EFH-227A (SP-16 ALESIS PWB is shown,  
but EFH-227A is not shown.)
- ⑧ EFH-221C
- ⑨ SWH-402A
- ⑩ SWH-400A
- ⑪ Power Supply Trans. Ass'y EPH-96

4. KEYBOARD ASS'Y

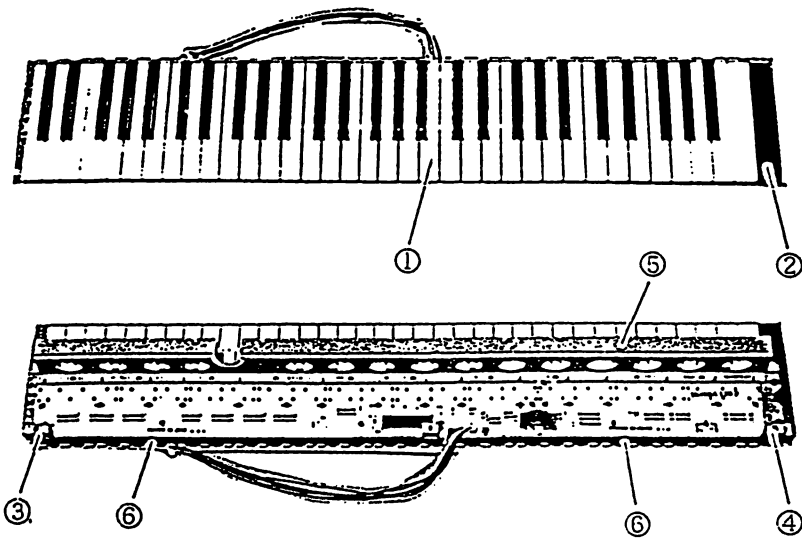

Ref.No.	Description	Part.No.
①	Keyboard Ass'y	105-17241
②	Endblock (R)	402-01944
③	Keyboard Bracket (Rear Left)	401-13373
④	" (Rear Right)	401-13374
⑤	" (Front)	401-13375
⑥	Key Stopper Metal Fittings	401-13396

5. FRONT PANEL ASS'Y

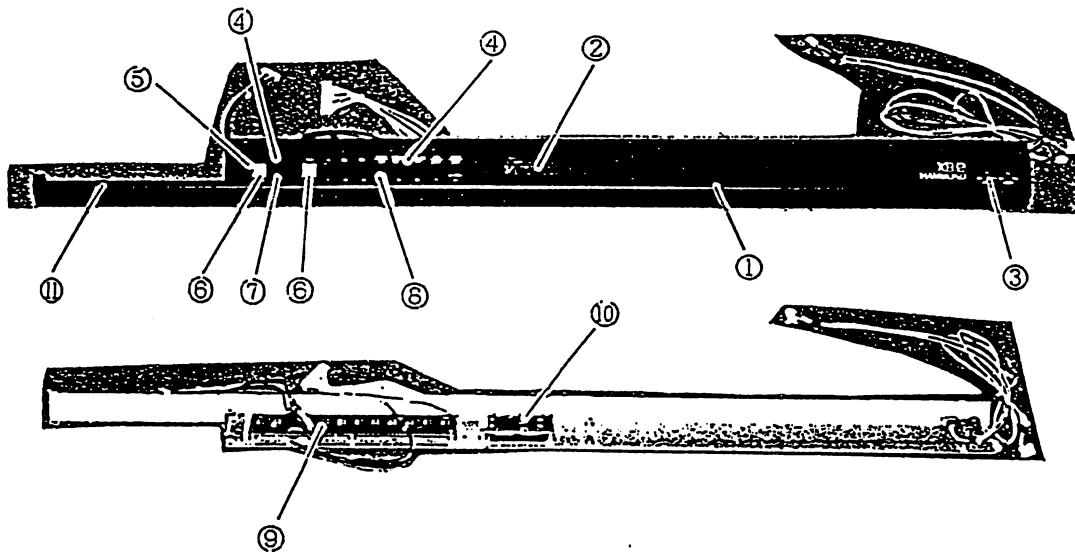

Ref.No.	Description	Part No.
①	Front Panel	401-13370
②	Display Cover H	402-01943
③	Volume Knob	304-02116
④	Switch Frame MD0340215	402-01946
⑤	" MD0340216	402-01947
⑥	Color Button TZ-0304	402-01948
⑦	" TZ-0410	402-01949
⑧	" TZ-0310	402-01950
⑨	P.W.B Ass'y SWH-400A	225-34206
⑩	LCD Unit Ass'y	105-17246
⑪	Electric Conductive Tape T-200, W-15mm, L-10cm	

6. TOP BOARD ASS'Y

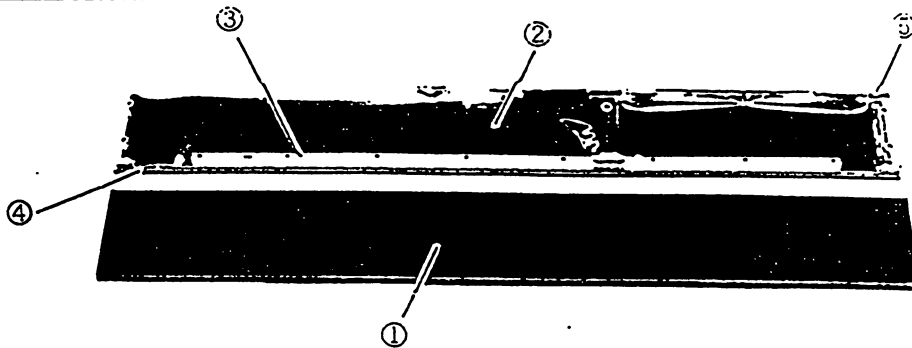

Ref. No.	Description	Part No.
①	Top Board Ass'y	402-22597
②	Aluminum Foil	402-02220
③	Top Board Support	401-13397
	Metal Fittings	
④	Top Board Cushion	402-06095
⑤	Key Felt H	402-03368

7. ENDBLOCK (L) ASS'Y

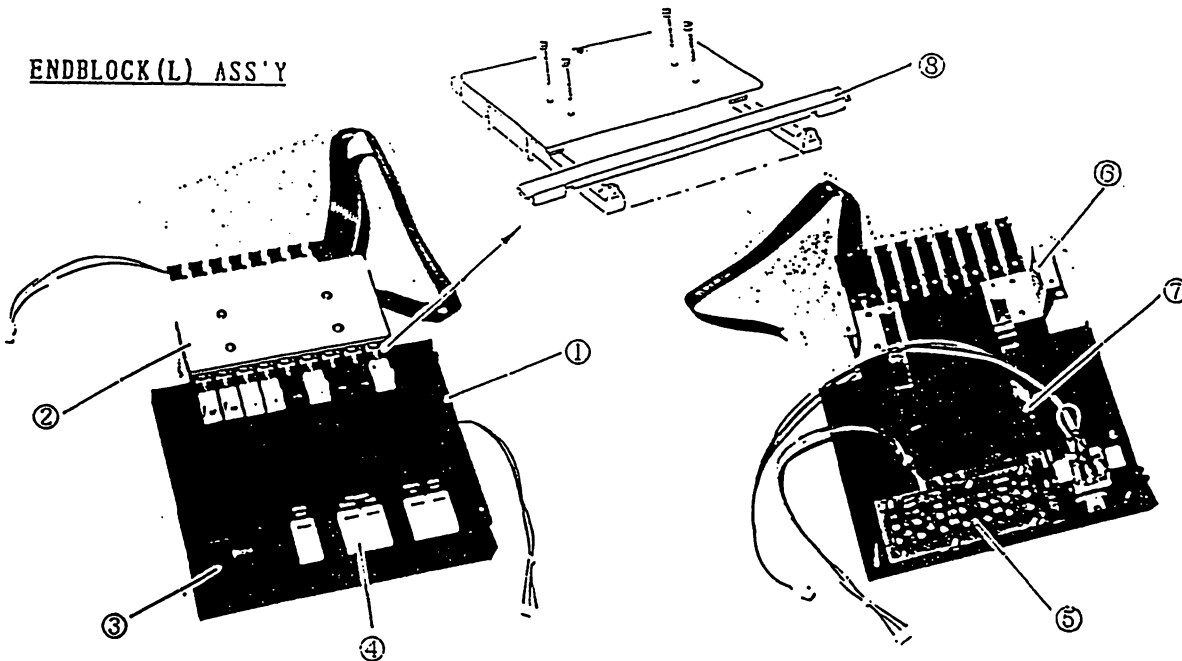

Ref. No.	Description	Part No.
①	Endblock (L)	402-01936
②	Drawbars Ass'y DB-209E	278-09206
③	Wheel Ass'y	105-17243
④	Key Top L2	279-01000A
⑤	P. W. B Ass'y SWH-402A	225-34216
⑥	Endblock Bracket	401-13369
⑦	Electric Conductive Tape	T-200.W-15mm
⑧	Endblock Plate	401-13368

Color	BEIGE	BEIGE	YG	YG	BLK	YG	BLK	BLK	YG
Letter	16'	5 <sup>1</sup> / <sub>3</sub> '	8'	4'	2 <sup>2</sup> / <sub>3</sub> '	2'	1 <sup>3</sup> / <sub>8</sub> '	1 <sup>1</sup> / <sub>3</sub> '	1'
Letter Color	BLK	BLK	RED	RED	WHT	RED	WHT	WHT	RED
Part No.206	-00221	-00220	-00209	-00208	-00215	-00207	-00214	-00213	-00206

Drawbar Knobs  
(DB-209E)

8. WHEEL ASS'Y

Wheel (bender side) Sub Ass'y

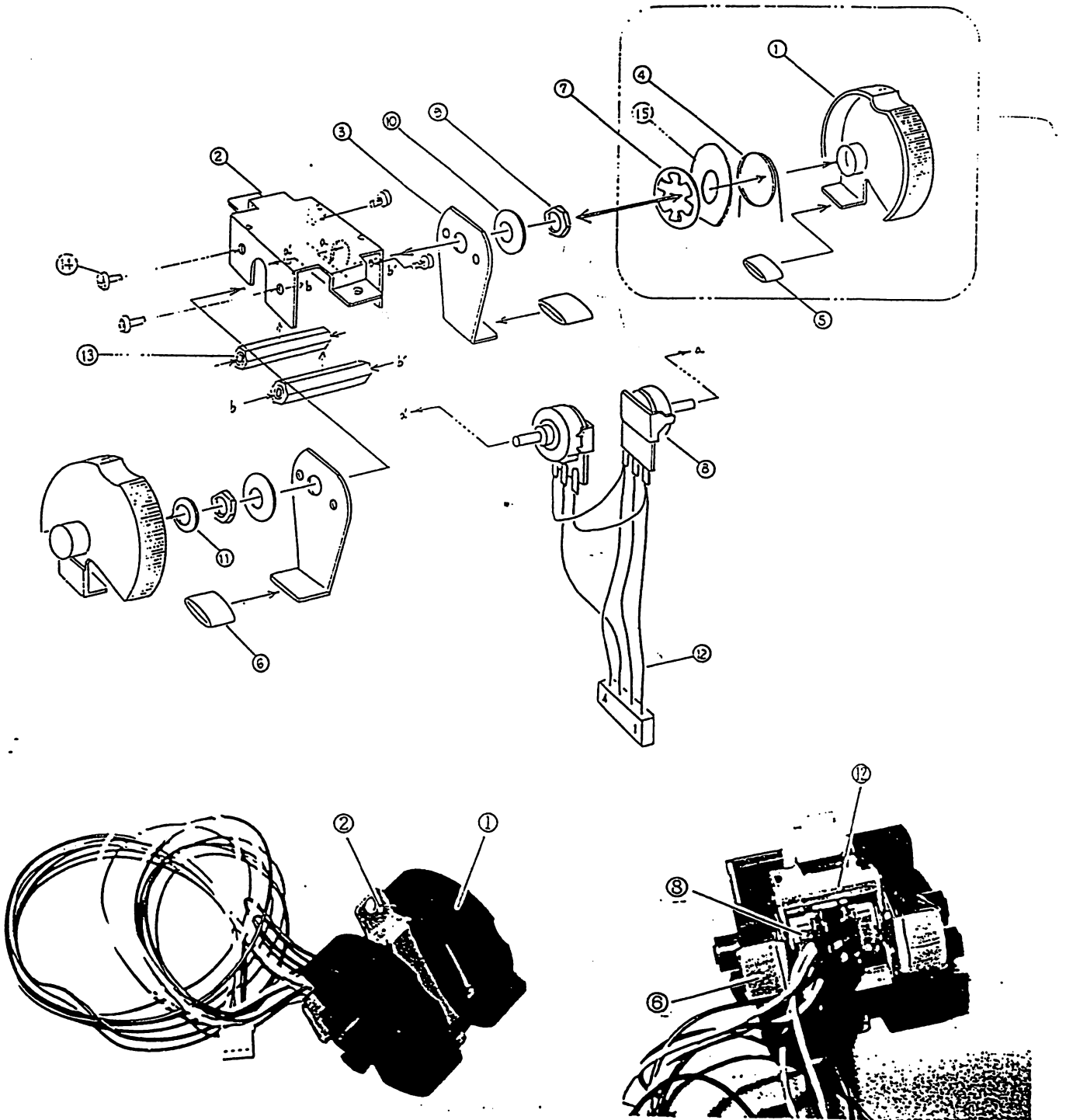

Ref.No. Description Part No.

- ① Wheel H 402-01935
- ② Bender Bracket 401-13362
- ③ Wheel Stopper 401-13363
- ④ Wheel Spring 401-06065
- ⑤ Vinyl Tube L6 402-01941
- ⑥ " L10 402-01942
- ⑦ CS Type Lock ring
- ⑧ Volume 10KB
- ⑨ Volume Nut M9

Ref.No. Description Part No.

- ⑩ Plain Washer
- ⑪ Felt Washer 402-03372
- ⑫ WR-V19 105-17413
- ⑬ Hexagon Long Nut 401-05122  
#25.8
- ⑭ Tapping Screw  
⊕ Truss M3x6 (ZnB)
- ⑮ Vinyl Chloride 402-01973  
Washer

9. EXPRESSION PEDAL ASS'Y (EXP-100A)

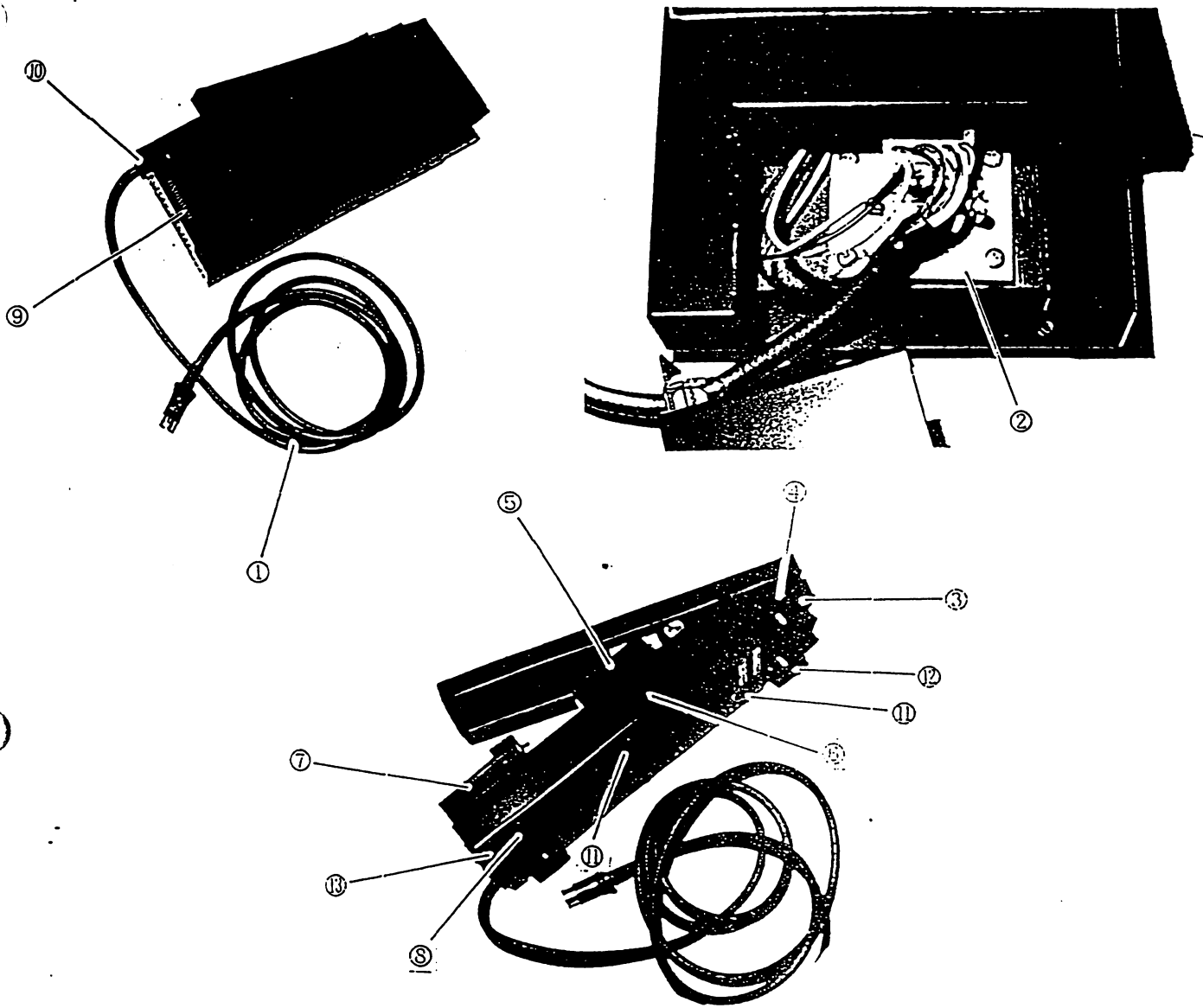

Ref. No.	Description	Part. No.
①	Wiring WR-EXP-100	109-76204
②	PWB Ass'y EFH-226A	223-41221
③	EXP. P. Base	402-22605
④	EXP. P. Cover (1)	401-12246
⑤	" (2)	401-12247
⑥	" (3)	401-12248
⑦	" (4)	401-12249
⑧	Rubber Foot K12 (7034)	
⑨	"HAMMOND" Seal	402-02226
⑩	Cord Bush R-5J (NA-5R)	
⑪	Tapping Screw (Atype)	φ 4x12. Bind. BLK
⑫	" (Atype)	φ 4x15. Bind. BLK (for Rubber Foot)
⑬	" (Btype)	φ 3x 3. Bind. BLK

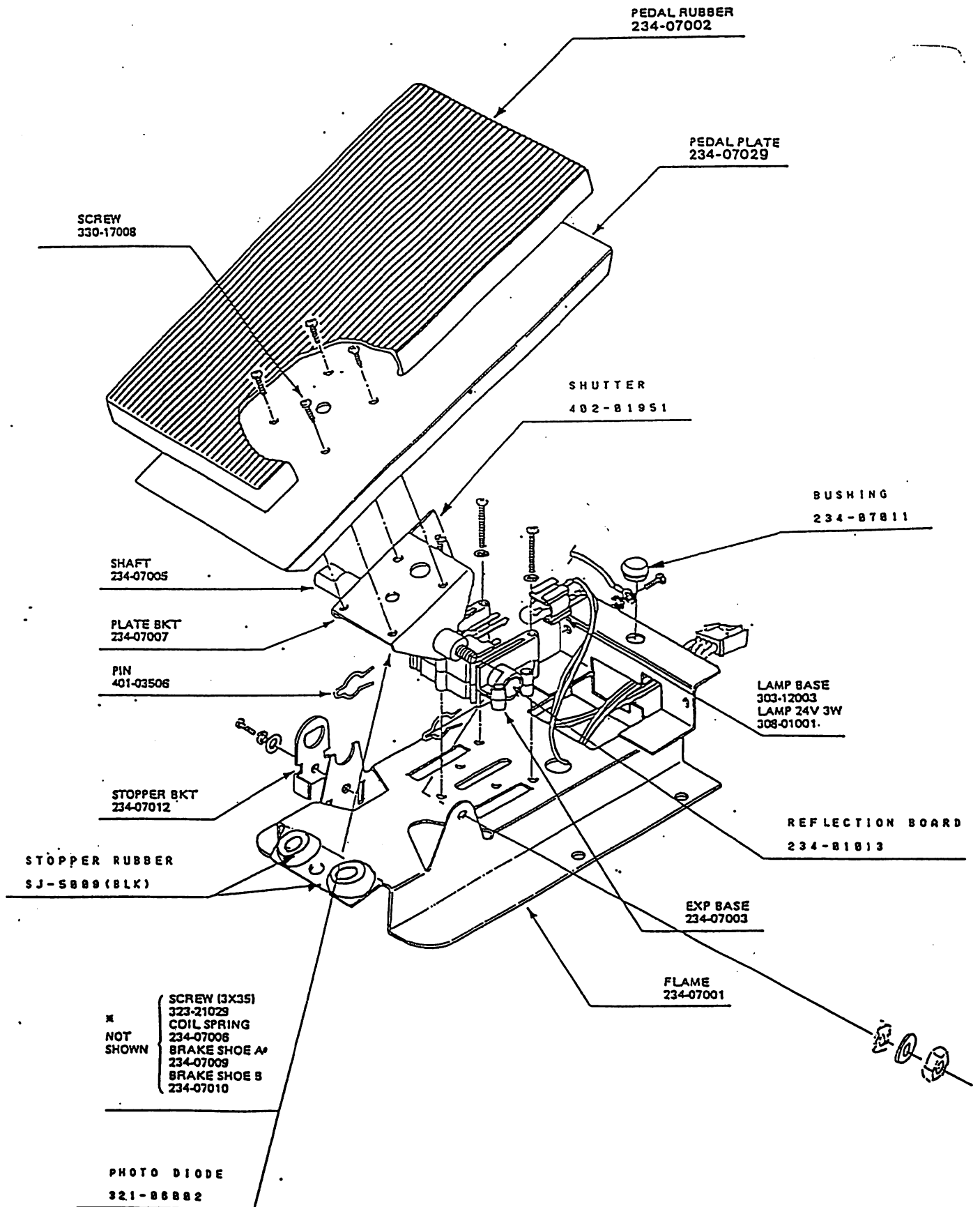

## ALL RESET

IF IT IS NECESSARY TO CHANGE P.W.B OR THE ROM AND RAM, THE "ALL RESET" SHOULD BE ACTIVATED.

**WARNING!** - The ALL RESET process returns the PRESET and PATCH data to the factory default settings. If it is necessary to save PRESET and PATCH information before doing an ALL RESET, refer to section 13 for information on the MEMORY DUMP.

1. Make sure the XB-2 is "OFF".
2. Touch and Hold the gray RECORD Select Touch Button.

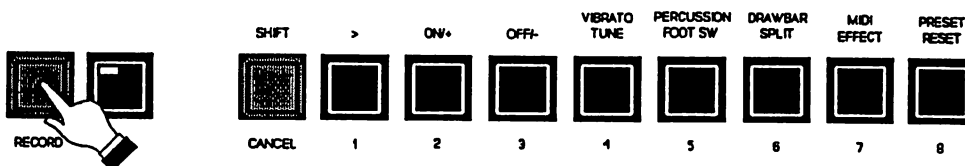

3. While continuing to hold the gray RECORD Select Touch Button, turn the Power Switch "ON". Once the LCD Display lights up, it should show the following:

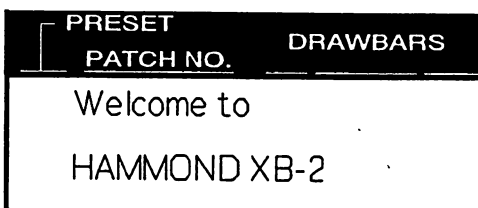

4. Continue to hold the gray RECORD Select Touch Button while the words, "HAMMOND XB-2" spell out from left to right on the bottom line of the LCD Display. As soon as the bottom line is completed, the display should change to the following for approximately 1 second:

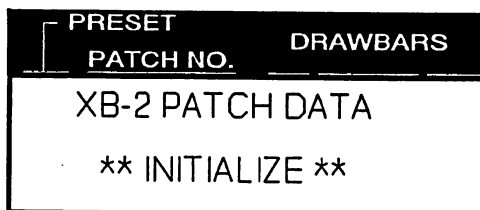

5. If all the Drawbars are "off" (pushed all the way in) the LCD Display should then change to a screen similar to this:

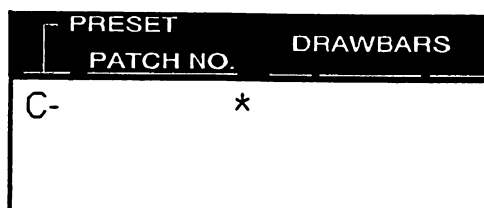

Release the gray RECORD Select Touch Button, and the XB-2 is ready for use.



## SOFTWARE VERSION

To determine the version of software in the instrument, do the following:

1. Touch the gray SHIFT/CANCEL Touch Button so the LCD Display shows the following:

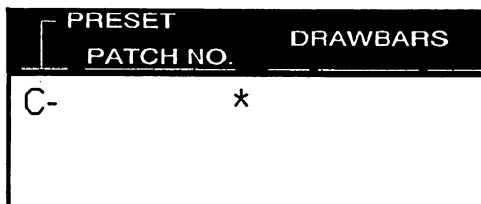

2. Touch the gray SHIFT/CANCEL Touch Button and the black number 3 Touch Button at the same time:

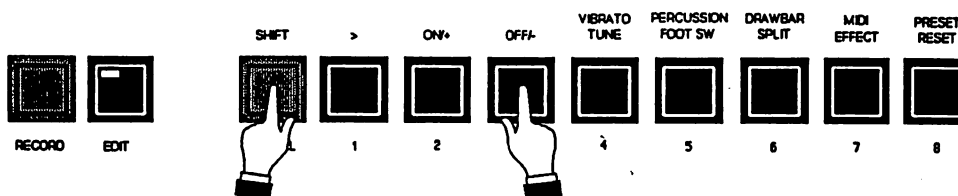

The LCD Display should show the software version:

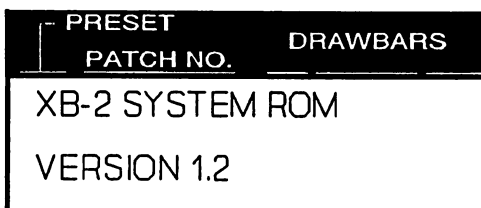

Refer to the following pages for an explanation of the differences between software versions.

**NOTE:** If system software is changed or upgraded, the PRESET and PATCH data will not be disturbed.

HAMMOND SUZUKI, LTD.

June 25, 1991

COMPARISON BETWEEN XB-2 V1.1 AND V1.2

POINTS	V1.1	V1.2
1- Losing Cancel Data (only Split Data)	Make Split Data on Cancel.   Press PRESET 1.   Press Cancel.   Loses previous Data.	This does not happen.
2- Modulation function at Overdrive ON	MODULATION DATA OUT regardless ON/OFF of Overdrive.	MODULATION DATA OUT at 0 when Overdrive is ON.
3- MIDI FOOT CONTROL function	Sends out only BASIC CHANNEL.	Sends out BASIC ch, ZONE 1ch and ZONE 2ch (total 3chs).
4- DRAW BAR (B-type) composition speed-up function	Gradually composes from Waves of low KEY DATA.	Selects Wave(s) of the KEY(s) switched ON.
5- Rare problem at PERCUSSION VELOCITY ON	Very rarely MAX sounds come out at PERCUSSION VELOCITY ON due to Convert. Table.	Corrected
6- PERCUSSION Volume at Split ON	Volume varies when Lower Key ON from when OFF. (PERC)	Corrected
7- LOWER VOICE	Lowest Octave Voice (only) does not change to BRITE VOICE when BRITE is selected at LOWER V.	Corrected
8- Losing Cancel Data (2nd case)	Make ALL Data on Cancel.   Press EDIT 8.   Press EDIT.   Loses previous Data.	This does not happen.

HAMMOND SUZUKI, LTD.

9- MIDI NRPN Change Addition	Leslie ON/OFF Sw. is not independent NRPN. (Includes Slow/Fast.)	Leslie ON/OFF Sw. is independent.
10- MIDI System common Message	System Message is the same as Real-time message.	Corrected.

## MEMORY DUMP

All 128 PATCHES can be programmed by the user. PATCHES 1 to 109 have factory settings and PATCHES 110 to 128 are blank. PATCH data can be transmitted to or received from another XB-2 or an outboard storage device such as a MIDI data recorder.

To transmit a MEMORY DUMP, do the following:

1. Using a standard MIDI cable, connect the XB-2 MIDI OUT to the MIDI IN of a receiving XB-2 or other outboard storage device.
2. Set up the receiving device to RECEIVE DATA. (NOTE: When sending to another XB-2, no additional setup is required.)
3. Touch and hold the gray SHIFT/CANCEL Touch Button.

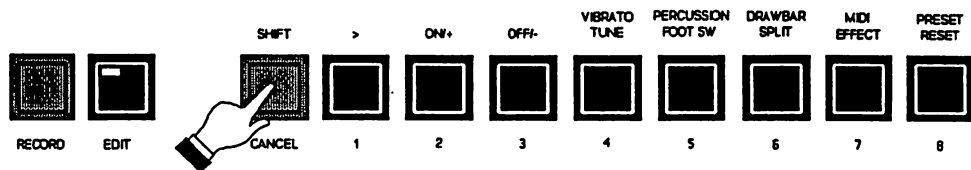

4. While holding the gray SHIFT/CANCEL Touch Button, touch the black number 8 Touch Button.

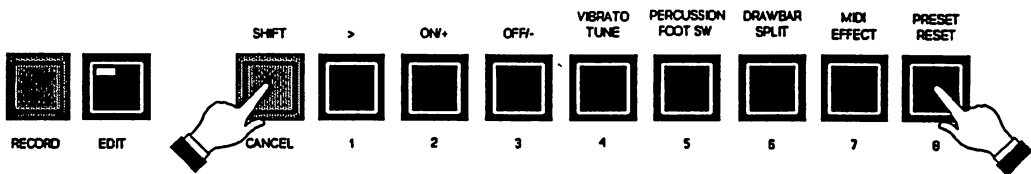

The LCD Display should look similar to this:

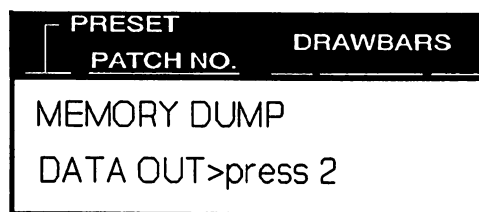

5. Touch the black number 2 [ON/+ ] Touch Button and the LCD Display should look similar to this:

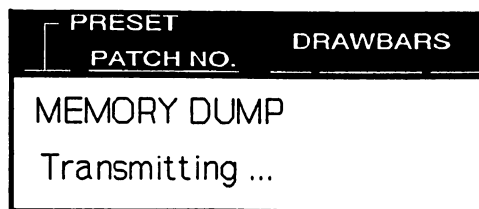

6. When the transfer is completed, the LCD Display will flash once, "Data Completed!".

To EXIT this menu, touch the CANCEL Touch Button.

To receive a MEMORY DUMP, do the following:

1. Using a standard MIDI cable, connect the XB-2 MIDI IN to the MIDI OUT of a sending XB-2 or other outboard storage device.
2. Set up the sending device to SEND DATA, and start transmitting. The LCD Display will show "Receiving Data" as soon as it starts receiving.
3. When the transfer is completed, the display will flash once, "Data Completed".

To EXIT this menu, touch the CANCEL Touch Button.

## DATA PROTECT

The data stored in the PATCHES can be PROTECTED so that it cannot be overwritten by accident.

To access the MEMORY DUMP - DATA PROTECT Menu Page, do the following:

1. Touch and hold the gray SHIFT/CANCEL Touch Button.

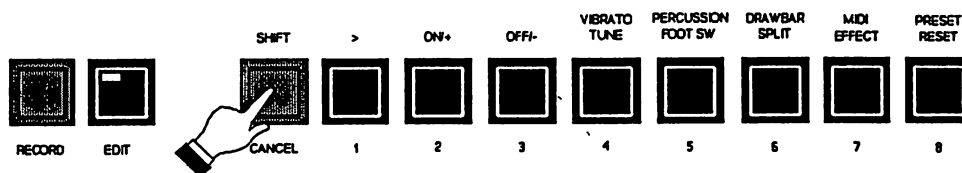

2. While holding the gray SHIFT/CANCEL Touch Button, touch the black number 8 Touch Button twice.



The LCD Display should look similar to this:

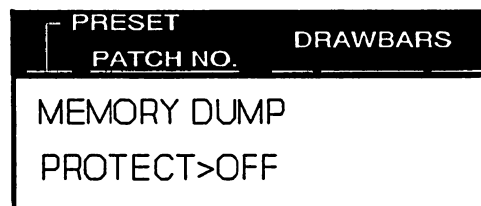

The default setting for PROTECT is "off".

Touch the black number 2 [ON/+] Touch Button to turn PROTECT "on".

Touch the black number 3 [OFF/-] Touch Button to turn PROTECT "off".

To EXIT this menu, touch the CANCEL Touch Button.

## **XB-2 ERROR MESSAGES**

### **1. CPU ERROR**

PRESET PATCH NO.	DRAWBARS
PLEASE POWER OFF!	
SYSTEM ERROR	00

PRESET PATCH NO.	DRAWBARS
PLEASE POWER OFF!	
SYSTEM ERROR	01

The above two messages indicate a CPU error. The MGH-61 MAIN BOARD should be replaced.

### **2. KEYSKAN ERROR**

PRESET PATCH NO.	DRAWBARS
PLEASE POWER OFF!	
KEYSCAN ERROR	

If the above message is displayed, check out the following:

1. Check the J114 (MGH-61) connector.
2. Change the MGH-61 MAIN BOARD.
3. Change a key on the keyboard if one is found to be faulty.

### **3. DRH ERROR**

PRESET PATCH NO.	DRAWBARS
PLEASE POWER OFF!	
MUSE ERROR	

This is an error in the Sound Generator. The MGH-61 MAIN BOARD should be replaced.