



Service Manual

Nakamichi 480Z

2 Head Cassette Deck



CONTENTS

1. General	3
2. Removal Procedures	4
2. 1. Cassette Case Cover Ass'y	4
2. 2. Top Cover Ass'y	4
2. 3. Bottom Cover Ass'y	4
2. 4. Front Panel Ass'y	5
2. 5. Headphone Jack Ass'y	5
2. 6. Mechanism Ass'y	5
2. 7. Level Indicator Ass'y, Lamp P.C.B. Ass'y and Indicator P.C.B. Ass'y	5
2. 8. Logic P.C.B. Ass'y, Headphone Switch P.C.B. Ass'y and MPX Filter Switch P.C.B. Ass'y	5
2. 9. Main P.C.B. Ass'y	6
2. 10. Control Switch Holder Ass'y	6
2. 11. Switch P.C.B. Ass'y	6
2. 12. Volume P.C.B. Ass'y and Control Switch P.C.B. Ass'y	6
2. 13. Rear Panel Ass'y, Power Transformer and Power Switch	8
2. 14. Cassette Case Ass'y and Cover Plate Ass'y	8
2. 15. Tape Counter Ass'y	8
2. 16. Capstan Motor Ass'y and Flywheel Ass'y	8
2. 17. Sub Mechanism Chassis Ass'y	9
2. 18. Control Motor Ass'y and Reel Motor Ass'y	9
2. 19. Cam Control Volume	9
2. 20. Reel Hub Ass'y and Idler Ass'y	9
2. 21. Cam Drive Gear and Control Cam	10
2. 22. Head Mount Base Ass'y	10
2. 23. Pressure Roller Ass'y and Erase Head	10
2. 24. Record/Playback Head Ass'y	10
3. Measurement Instruments	11
4. Mechanical Adjustments	11
4. 1. Mechanism Control Cam Adjustment	11
4. 2. Tape Speed Adjustment	12
4. 3. Record/Playback Head Tilt Adjustment	13
4. 4. Head Base Stroke Adjustment	14
4. 5. Tape Guides Adjustment and Erase Head Stroke Adjustment	14
4. 6. Erase Head Height and Tilt Adjustment	15
4. 7. Back Tension Adjustment	15
4. 8. Record/Playback Head Height Adjustment and Azimuth Alignment	16
4. 9. Tape Travelling Adjustment	17
4. 10. Record Switch Linkage Adjustment	17
4. 11. Flywheel Holder Adjustment	18
4. 12. Eject Wire Adjustment	18
4. 13. Lubrication	18
5. Parts Location for Electrical Adjustment	19
6. Electrical Adjustments and Measurements	20
6. 1. Adjustment and Measurement Instructions	20
6. 2. Playback Frequency Response Adjustment	23
6. 3. Dolby NR Circuit Check	24
7. Mounting Diagrams and Parts List	25
7. 1. Main P.C.B. Ass'y	25
7. 2. Volume P.C.B. Ass'y	31
7. 3. Lamp P.C.B. Ass'y	31
7. 4. MPX Filter Switch P.C.B. Ass'y	31
7. 5. Headphone Switch P.C.B. Ass'y	31
7. 6. Bias Tune Volume P.C.B. Ass'y	31
7. 7. Indicator P.C.B. Ass'y	31
7. 8. Switch P.C.B. Ass'y	31
7. 9. Shut-off P.C.B. Ass'y	32

7. 10.	Control P.C.B. Ass'y	32
7. 11.	Control Switch P.C.B. Ass'y	32
7. 12.	Logic P.C.B. Ass'y	33
8.	Mechanism Ass'y and Parts List	37
8. 1.	Synthesis	37
8. 2.	Front Panel Ass'y (A01)	39
8. 3.	Synthesis Mechanism Ass'y (A02)	39
8. 4.	Meter Escutcheon Ass'y (B01)	41
8. 5.	Control Switch Holder Ass'y (B02)	41
8. 6.	Headphone Jack Ass'y (B03)	42
8. 7.	Mechanism Ass'y 480Z (B04)	43
8. 8.	Chassis Ass'y (B05)	44
8. 9.	Flywheel Holder Ass'y (C01)	44
8. 10.	Sub Mechanism Chassis Ass'y (C02)	45
8. 11.	Main Mechanism Chassis Ass'y (C03)	46
8. 12.	Rear Panel Ass'y (D01)	47
8. 13.	Capstan Motor Ass'y (E01)	48
8. 14.	Reel Motor Ass'y (F01)	48
8. 15.	Control Motor Ass'y (F02)	48
8. 16.	Head Mount Base Ass'y (G01)	48
8. 17.	Supply Pressure Roller Ass'y (G02)	48
8. 18.	Take-up Pressure Roller Ass'y (G03)	49
8. 19.	Head Base Ass'y C (G04)	49
8. 20.	Cassette Case Holder L Ass'y (G05)	49
8. 21.	Cassette Case Holder R Ass'y (G06)	49
8. 22.	Auto Shut-off Ass'y (G07)	49
8. 23.	Pneumatic Damper Ass'y (G08)	49
8. 24.	RP-9E Record/Playback Head Ass'y (H01)	50
9.	Overall Timing Chart	51
10.	Eq. Amp. Frequency Response	52
10. 1.	Playback Frequency Response	52
10. 2.	Record Current Frequency Response	52
11.	Wiring Diagram	53
12.	Block Diagrams	55
12. 1.	Amplifier Section	55
12. 2.	Mechanism Control Section	56
13.	Schematic Diagrams	57
13. 1.	IC Block Diagram	57
13. 2.	Attention to Servicemen	57
13. 3.	Mechanism Control Section	58
13. 4.	Amplifier Section	60
14.	Specifications	62

480Z

1. GENERAL

1.1. Control Functions

The Nakamichi 480Z control functions are shown below:

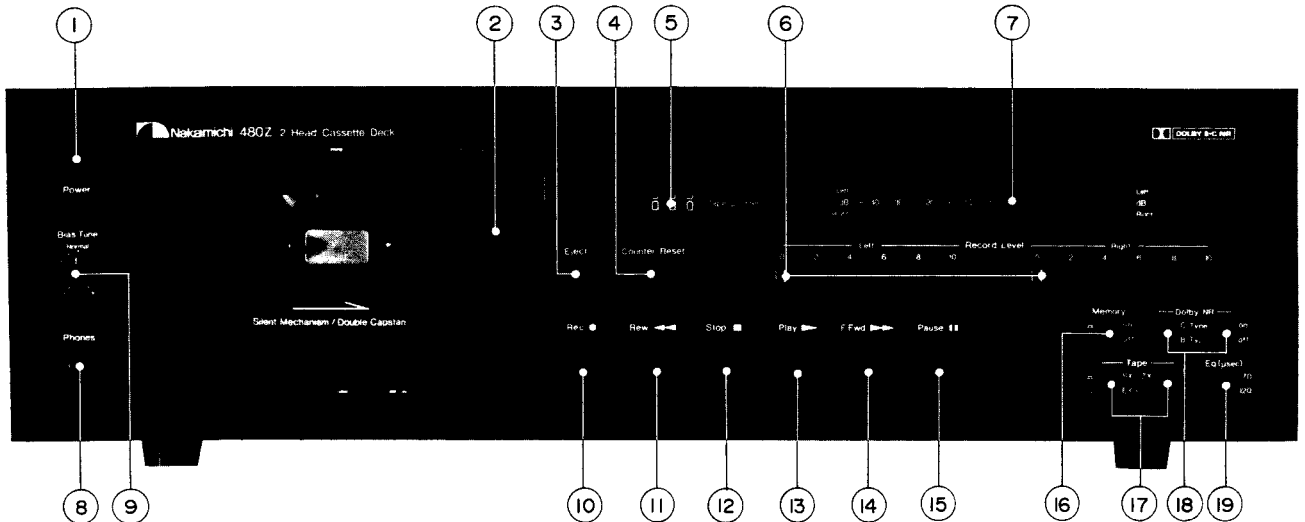

Fig. 1.1 Front View

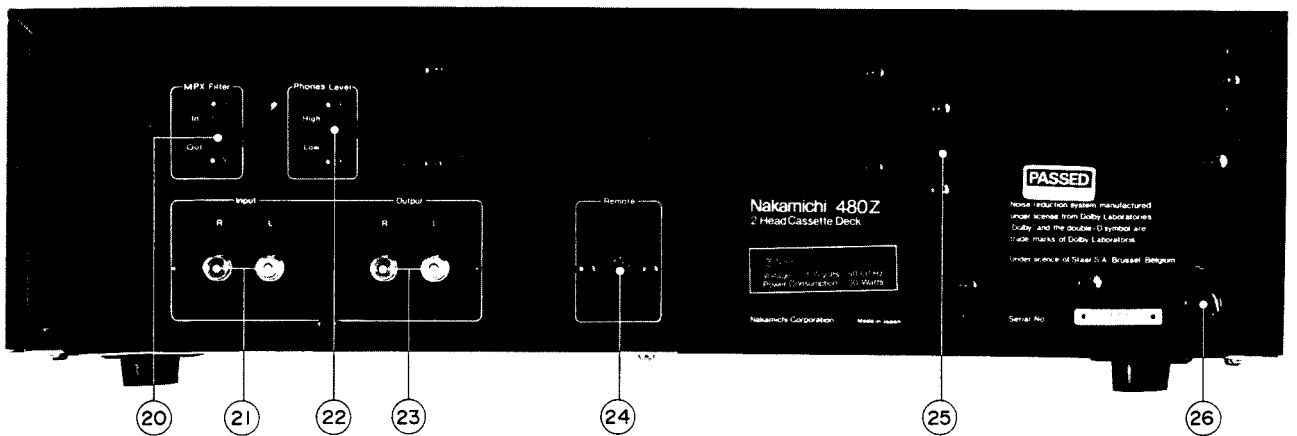

Fig. 1.2 Rear View

- | | | |
|-------------------------|--------------------------|-----------------------------|
| 1. Power Switch | 10. Record Button | 19. Eq. Switch |
| 2. Cassette Lid | 11. Rewind Button | 20. MPX Filter Switch |
| 3. Eject Button | 12. Stop Button | 21. Input Jacks |
| 4. Counter Reset Button | 13. Play Button | 22. Headphone Level Switch |
| 5. Tape Counter | 14. Fast-Forward Button | 23. Output Jacks |
| 6. Input Level Controls | 15. Pause Button | 24. Remote Control Socket |
| 7. Peak Level Meters | 16. Tape Memory Switch | 25. Voltage Selector Switch |
| 8. Headphone Jack | 17. Tape Selector Switch | 26. Power Cord |
| 9. Bias Tune Control | 18. Dolby NR Switch | |

1.2. Voltage Selector

Voltage Selector is installed on the rear panel for Other Version of the Nakamichi 480Z. This voltage selector can select either 120 V or 220-240 V at customer's disposal.

2. REMOVAL PROCEDURES

2.1. Cassette Case Cover Ass'y

Refer to Fig. 2.1.

- (1) Press the Eject Button to open the Cassette Case Ass'y.
- (2) Pull out F01 (Cassette Case Cover Ass'y) upwardly.

2.3. Bottom Cover Ass'y

Refer to Fig. 2.1.

- (1) Remove F05, then disassemble F06 (Bottom Cover Ass'y).

2.2. Top Cover Ass'y

Refer to Fig. 2.1.

- (1) Remove F02 and F03, then disassemble F04 (Top Cover Ass'y).

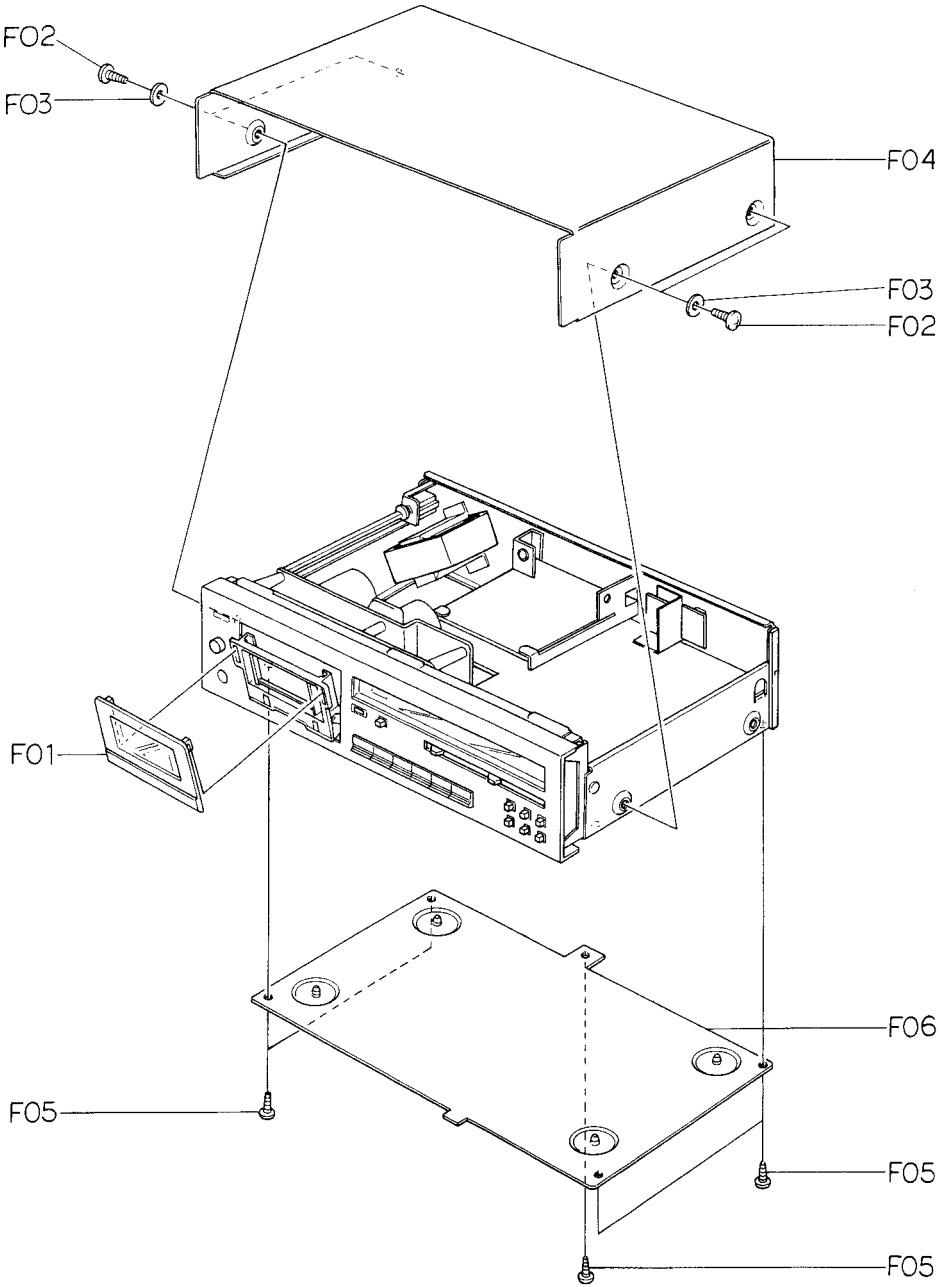

Fig. 2.1

2.4. Front Panel Ass'y

Refer to Fig. 2.2.

- (1) Refer to Fig. 2.1. Remove Top Cover Ass'y and Bottom Cover Ass'y referring to items 2.2 and 2.3.
- (2) Pull out F01 (Volume Knobs) and F02 (Bias Tune Volume Knob).
- (3) Remove F03 (Power Switch Joint Bar) by releasing the self-interlocking pin of the Power Switch Joint Bar from Power Switch, and turn F03 (Power Switch Joint Bar) by 90° either clockwise or counterclockwise, then disassemble F03 (Power Switch Joint Bar) from the Power Switch Knob Ass'y.
- (4) Remove F04, then disassemble F05 (Front Panel Ass'y).

2.5. Headphone Jack Ass'y

Refer to Fig. 2.2.

- (1) Remove Front Panel Ass'y referring to item 2.4.
- (2) Remove F06, then disassemble F07 (Headphone Jack Ass'y).
- (3) Remove F08 and F09, then disassemble F10 (Bias Tune Volume P.C.B. Ass'y).
- (4) Remove F11 and F12, then disassemble F13 (Headphone Jack).

2.6. Mechanism Ass'y

Refer to Fig. 2.2.

- (1) Remove Front Panel Ass'y referring to item 2.4.
- (2) Remove F14 and F15, then disassemble F16 (Mechanism Ass'y including 5 connectors and Record Switch Linkage).

2.7. Level Indicator Ass'y, Lamp P.C.B. Ass'y and Indicator P.C.B. Ass'y

Refer to Fig. 2.2.

- (1) Remove Front Panel Ass'y referring to item 2.4.
- (2) Remove F17 (Level Indicator Ass'y) by releasing self-interlocking pins of Level Indicator Ass'y.
- (3) Remove F18, then disassemble F19 (Lamp P.C.B. Ass'y).
- (4) Remove F20, then disassemble F21 (Shield Case).
- (5) Remove F22, then disassemble F23 (Indicator P.C.B. Ass'y).

2.8. Logic P.C.B. Ass'y, Headphone Switch P.C.B. Ass'y and MPX Filter Switch P.C.B. Ass'y

Refer to Fig. 2.3.

- (1) Refer to Fig. 2.1. Remove Top Cover Ass'y referring to item 2.2.

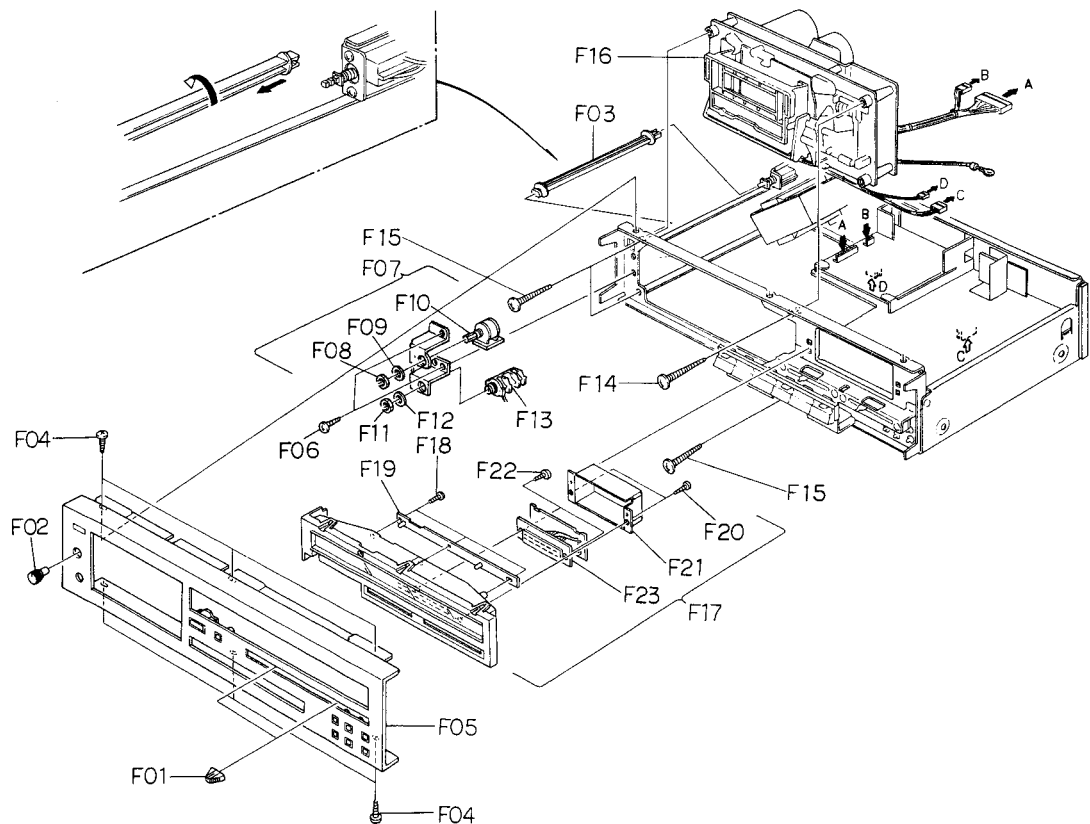

Fig. 2.2

- (2) Remove F01 and F02, then disassemble F03 (Logic P.C.B. Ass'y).
- (3) Remove F04, then disassemble F05 (Headphone Switch P.C.B. Ass'y and Shield Case).
- (4) Remove F06, then disassemble F07 (MPX Filter Switch P.C.B. Ass'y).

2.9. Main P.C.B. Ass'y

Refer to Fig. 2.3.

- (1) Refer to Fig. 2.2. Remove Front Panel Ass'y, Logic P.C.B. Ass'y and Headphone Switch P.C.B. Ass'y referring to items 2.4 and 2.8.
- (2) Remove 2 connectors and the wires connected by wrapping from the F13 (Main P.C.B. Ass'y).
- (3) Remove F08, F09, F10, F11, F12 and the Record Switch Linkage from the Wire Holder of Record Switch, then disassemble F13 (Main P.C.B. Ass'y).

2.10. Control Switch Holder Ass'y

Refer to Fig. 2.3.

- (1) Refer to Fig. 2.2. Remove Level Indicator Ass'y referring to item 2.7.

- (2) Remove F14, then disassemble F15 (Control Switch Holder Ass'y).

2.11. Switch P.C.B. Ass'y

Refer to Fig. 2.3.

- (1) Refer to Fig. 2.2. Remove Front Panel Ass'y referring to item 2.4.
- (2) Remove F16, then disassemble F17 (Switch P.C.B. Ass'y).

2.12. Volume P.C.B. Ass'y and Control Switch P.C.B. Ass'y

Refer to Fig. 2.3.

- (1) Remove Control Switch Holder Ass'y referring to item 2.10.
- (2) Remove F18, then disassemble F19 (Volume P.C.B. Ass'y).
- (3) Remove F20, then disassemble F21 (Control Button Spring).
- (4) Remove F22 (Control Button Shaft), then disassemble F23 (Control Buttons).
- (5) Remove F24, then disassemble F25 (Control Switch P.C.B. Ass'y).

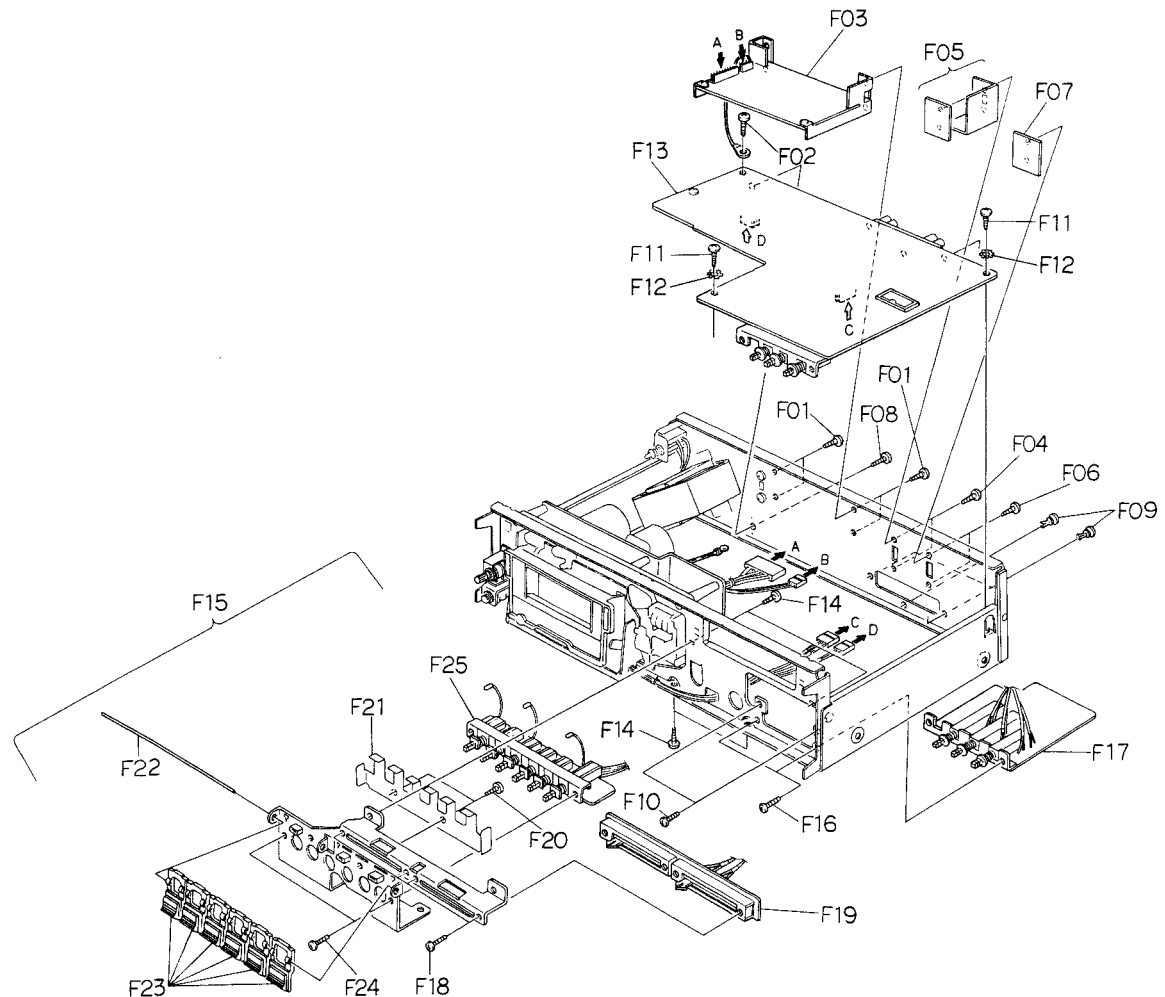

Fig. 2.3

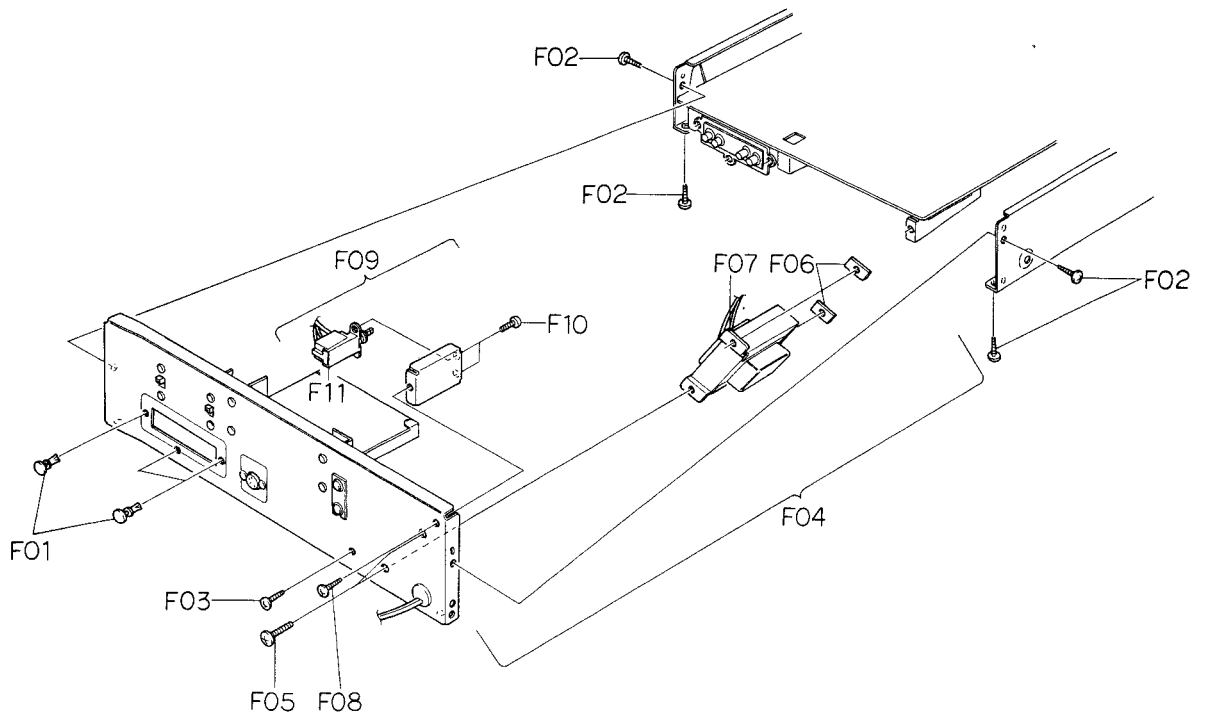

Fig. 2.4

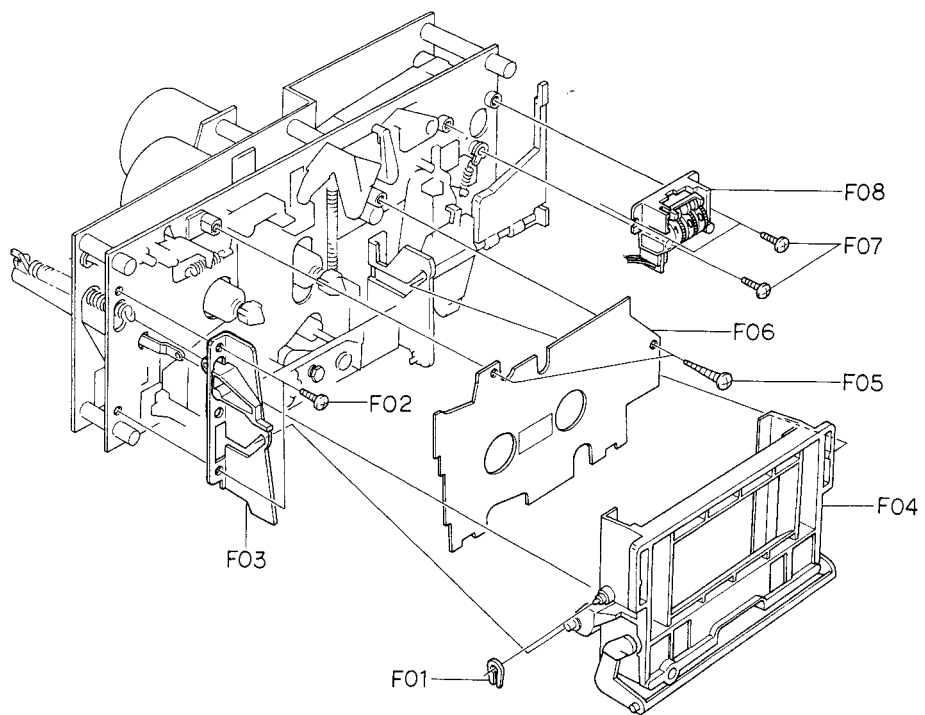

Fig. 2.5

2.13. Rear Panel Ass'y, Power Transformer and Power Switch

Refer to Fig. 2.4.

- (1) Refer to Fig. 2.1. Remove Top Cover Ass'y and Bottom Cover Ass'y referring to items 2.2 and 2.3.
- (2) Remove F01, F02 and F03, then disassemble F04 (Rear Panel Ass'y).
- (3) Remove F05 and F06, then disassemble F07 (Power Transformer).
- (4) Remove Power Switch Joint Bar by releasing the self-interlocking pin of the Power Switch Joint Bar from Power Switch and F08, then disassemble F09 (Power Switch Holder Ass'y).
- (5) Remove F10, then disassemble F11 (Power Switch).

2.14. Cassette Case Ass'y and Cover Plate Ass'y

Refer to Fig. 2.5.

- (1) Refer to Fig. 2.2. Remove Mechanism Ass'y referring to item 2.6.
- (2) Press the Eject Button to open the Cassette Case Ass'y.
- (3) Remove F01, then disassemble the piston of the Pneumatic Damper Ass'y.
- (4) Remove F02 and F03 (Cassette Case Holder L Ass'y), then disassemble F04 (Cassette Case Ass'y).
- (5) Remove F05, then disassemble F06 (Cover Plate Ass'y).

2.15. Tape Counter Ass'y

Refer to Fig. 2.5.

- (1) Refer to Fig. 2.2. Remove Level Indicator Ass'y referring to item 2.7.
- (2) Remove F07, then disassemble F08 (Tape Counter Ass'y).

2.16. Capstan Motor Ass'y and Flywheel Ass'y

Refer to Fig. 2.6.

- (1) Refer to Fig. 2.2. Remove Mechanism Ass'y referring to item 2.6.
- (2) Remove F01 and F02, then disassemble F03 (Flywheel Holder Ass'y) and F08 (Capstan Belt).
- (3) Remove F04, then disassemble F05 (Capstan Motor Ass'y).
- (4) Remove F06, then disassemble F07 (Control P.C.B. Ass'y).
- (5) Remove F09 (Supply Flywheel Ass'y), then disassemble F10 (Take-up Flywheel Ass'y).
- (6) After removing both Flywheel Assemblies, disassemble F11 (Thrust Washer 3 mm), F12 (Thrust Washer 2.6 mm), F13 (Flange Thrust Caps) and F14 (Flange Thrust Springs).

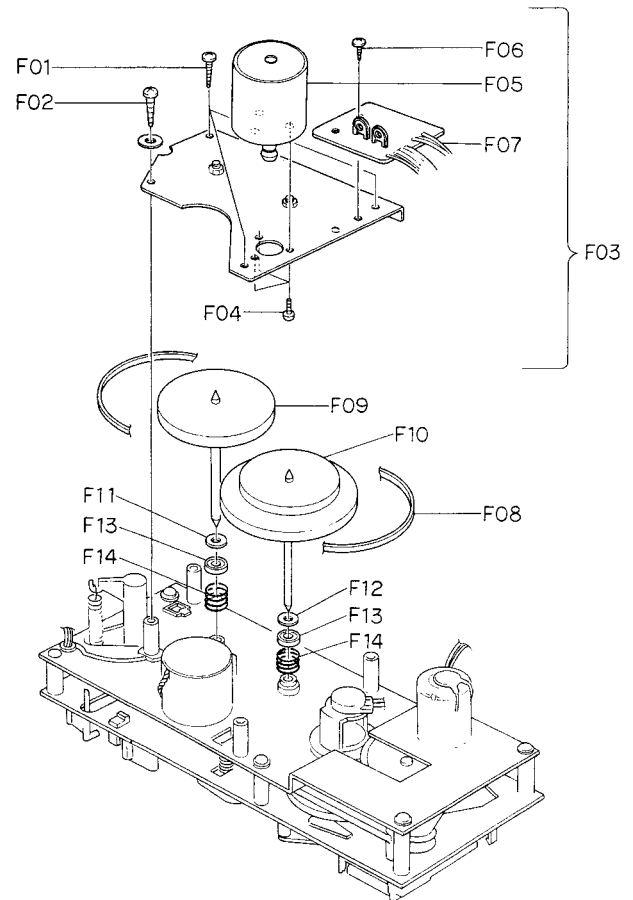

Fig. 2.6

2.17. Sub Mechanism Chassis Ass'y

Refer to Fig. 2.7.

- (1) Refer to Fig. 2.6. Remove Flywheel Assemblies referring to item 2.16.
- (2) Remove F01 and F02, then disassemble F03 (Sub Mechanism Chassis Ass'y).

2.18. Control Motor Ass'y and Reel Motor Ass'y

Refer to Fig. 2.7.

- (1) Remove Sub Mechanism Chassis Ass'y referring to item 2.17.
- (2) Remove F04, then disassemble F05 (Control Motor Ass'y).
- (3) Remove F06, then disassemble F07 (Reel Motor Ass'y).

2.19. Cam Control Volume

Refer to Fig. 2.7.

- (1) Remove Sub Mechanism Chassis Ass'y referring to item 2.17.
- (2) Remove F08, then disassemble F09 (Volume Coupler).
- (3) Remove F10, then disassemble F11 (Cam Control Volume).

2.20. Reel Hub Ass'y and Idler Ass'y

Refer to Fig. 2.7.

- (1) Remove Sub Mechanism Chassis Ass'y referring to item 2.17.
- (2) Remove F12 (Reel Hub Heads), then disassemble F13 (Reel Hub B Assemblies), F14 (Reel Hub Take-up

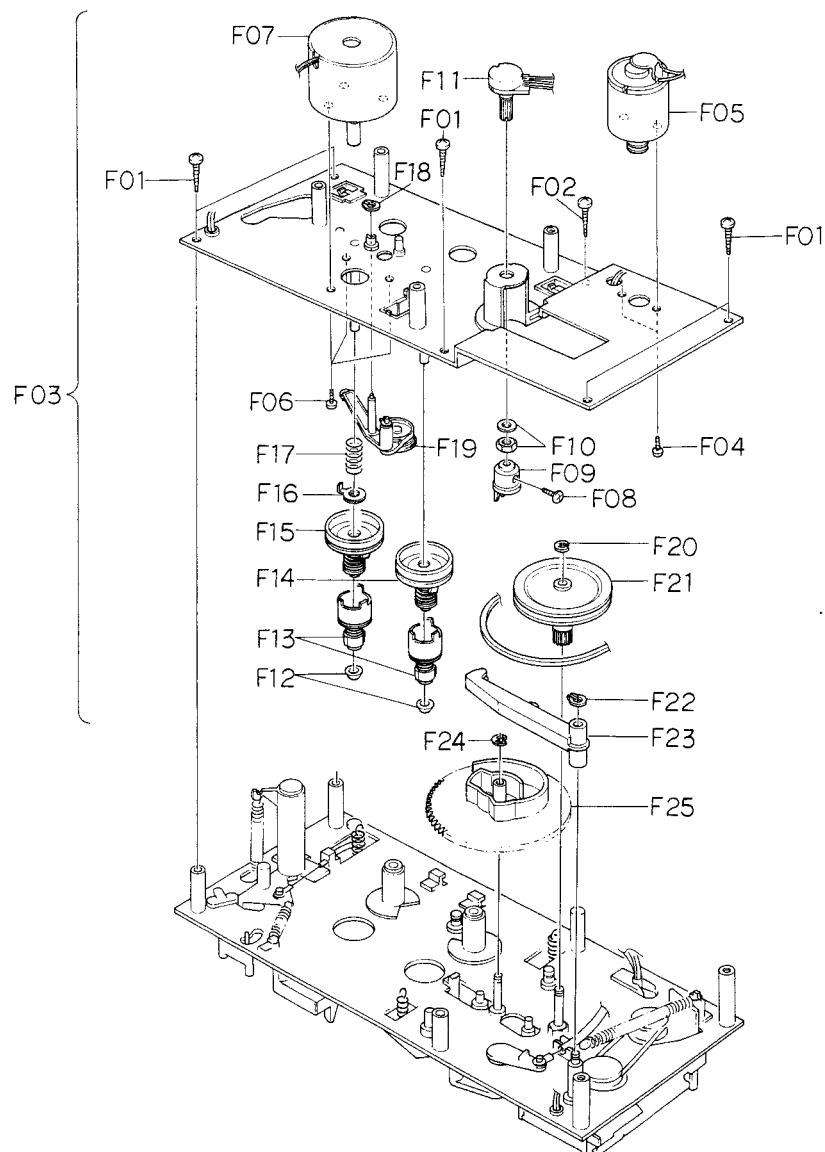

Fig. 2.7

Ass'y), F15 (Reel Hub Supply Ass'y), F16 (Back Tension Ass'y) and F17 (Back Tension Spring).

- (3) Remove F18, then disassemble F19 (Idler Ass'y).

2.21. Cam Drive Gear and Control Cam

Refer to Fig. 2.7.

- (1) Remove Sub Mechanism Chassis Ass'y referring to item 2.17.
- (2) Remove F20, then disassemble F21 (Cam Drive Gear).
- (3) Remove F22, then disassemble F23 (Counter-Load Arm Ass'y).
- (4) Remove F24, then disassemble F25 (Control Cam).

2.22. Head Mount Base Ass'y

Refer to Fig. 2.8.

- (1) Refer to Fig. 2.5. Remove Cassette Case Ass'y referring to item 2.14.
- (2) Remove F01, then disassemble F02 (Head Mount Base Ass'y).

2.23. Pressure Roller Ass'y and Erase Head

Refer to Fig. 2.8.

- (1) Remove Head Mount Base Ass'y referring to item 2.22.
- (2) Remove F03 and a washer, then disassemble F04 (Supply Pressure Roller Ass'y).
- (3) Remove F05, then disassemble F06 (Erase Head).
- (4) Remove F07 and a washer, then disassemble F08 (Take-up Pressure Roller Ass'y).

2.24. Record/Playback Head Ass'y

Refer to Fig. 2.8.

- (1) Remove Head Mount Base Ass'y referring to item 2.22.
- (2) Turn F09 by 90° by pushing it, then disassemble F10 (Record/Playback Head Ass'y).

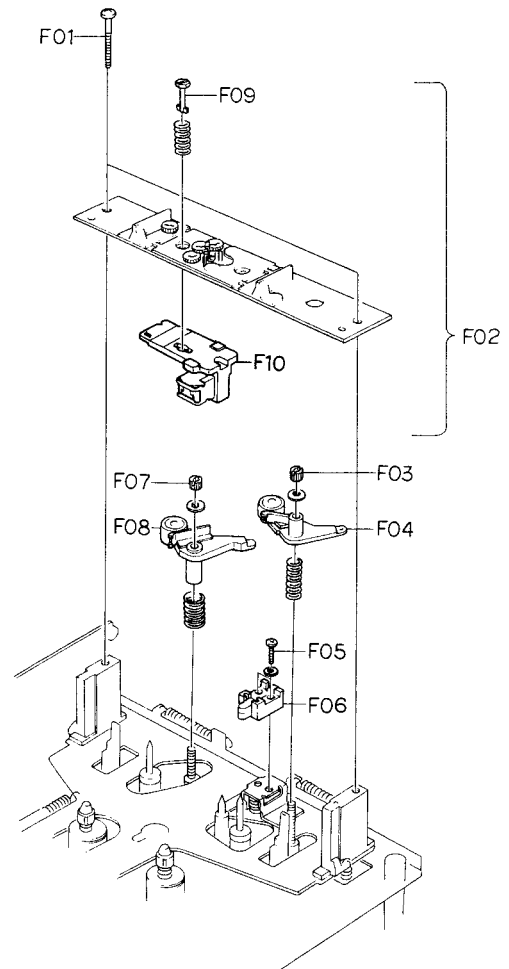

Fig. 2.8

3. MEASUREMENT INSTRUMENTS

- (1) Audio Generator (20 Hz – 200 kHz)
- (2) AC Millivolt Meter (with dB measures)
- (3) Oscilloscope (DC – 5 MHz)
- (4) Distortion Meter
- (5) Speed & Wow/Flutter Meter
- (6) Frequency Counter (DC – 1 MHz)
- (7) Ohm Meter
- (8) DC Volt Meter
- (9) AC Volt Meter
- (10) Torque Gauge (DA09013A)
- (11) 15 kHz Azimuth Tape (DA09004A)
- (12) 3 kHz Speed & Wow/Flutter Tape (DA09006A)
- (13) 1 kHz Track Alignment Tape (DA09007A)
- (14) 400 Hz Level Tape (DA09005A)
- (15) 20 kHz PB Frequency Response Tape (DA09001A)
- (16) 15 kHz PB Frequency Response Tape (DA09002A)
- (17) 10 kHz PB Frequency Response Tape (DA09003A)
- (18) Reference EXII Tape (DA09066A)
- (19) Reference SX Tape (DA09025A)
- (20) Reference ZX Tape (DA09037A)
- (21) Tilt Check Gauge M-9036 (DA09036A)
- (22) Stroke Check Gauge M-9038 (DA09038A)
- (23) EH Tilt Check Gauge M-9040 (DA09040A)
- (24) EH Stroke Check Gauge M-9051 (DA09051A)
- (25) Back Tension Gauge (DA09055A)
- (26) Tension Arm Adjustment Cassette (DA09056A)
- (27) Audio Analyzer T-100
(including Distortion, Wow/Flutter, Speed, Oscillator and dB meters)

Note: (10) – (27) are the products of Nakamichi Corporation.

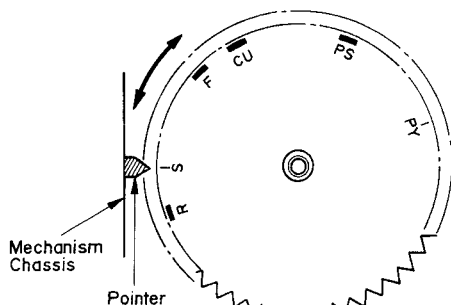

Fig. 4.1

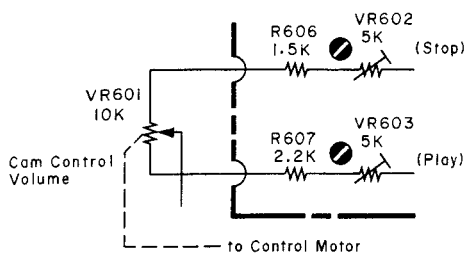

Fig. 4.2

4. MECHANICAL ADJUSTMENTS

4.1. Mechanism Control Cam Adjustment

Before adjustment, disassemble the Front Panel Ass'y then remove the Cover Plate Ass'y referring to items 2.4 and 2.14.

(1) Offset Adjustment of Control Motor Driver

(a) Refer to Figs. 4.1 and 4.2.

Adjust VR602 and VR603 on the Control P.C.B. Ass'y to locate approximately at the middle of the variable range. Then turn ON the Power switch.

VR602 (for cam position stop)

VR603 (for cam position play)

(b) Press the Stop button to set the N-480Z in Stop mode. Adjust VR602 (for stop) so that the "S" mark on the Cam corresponds to the pointer on the mechanism chassis.

(c) Press the Play button to set the N-480Z in Playback mode.

(Cam will rotate, and the position marked with "PY" comes to the pointer.)

Adjust VR603 (for play) so that the "PY" mark on the Cam corresponds to the pointer.

(d) Repeat above (b) and (c) 2 – 3 times so that the "S" and "PY" marks on the Cam correspond to the pointer accurately in Stop and Playback modes respectively.

(This adjustment is required because the position adjusted by one volume will be slightly changed when the other volume is adjusted.)

(e) Set the N-480Z in F.F., Pause, or Record mode by pressing each button and check to insure that the pointer is in a range of "F", "PS", or "R" mark respectively.

(f) If out of the range, precise adjustment for each position according to "(2) Offset Fine Adjustment of Control Motor Driver" will be required.

(2) Offset Fine Adjustment of Control Motor Driver

Adjust only if a satisfactory result is not obtained in "(1) Offset Adjustment of Control Motor Driver". This adjustment is made by changing the value of the fixed resistors on the Logic P.C.B. Ass'y.

Note: The value of voltage is typical value.

(a) Observation Point of Reference Voltage

Observe the each voltage at the sliding contact of the Cam Control Volume VR601 (10 kΩ) in Stop, Fast (F.F. or Rew.), Pause, Record and Playback modes.

Note: When Record and Play buttons are pressed to set the N-480Z in Record mode, the Cam is first set to the record position in a short period of time then stays at the play position. Therefore to keep the Cam at the record position, following procedure is required:

Short both leads of capacitor C417 (2.2 μF) on the Logic P.C.B. with a jumper wire, then press the Record and Play buttons.

(b) Reference Voltage

Reference voltage at the sliding contact of VR601 (Cam Control Volume) in each mode is as follows:

Mode	Reference Voltage (Typical Value)
Record	16 V
Stop	15 V
Fast (F.F./Rew.)	13.5 V
Pause	10 V
Play	7.5 V

Adjustment ranges for the reference voltages:

- Record: $1 \text{ V } \begin{matrix} +0.4 \text{ V} \\ -0.2 \text{ V} \end{matrix}$
- Fast (F.F./Rew.): $1.5 \text{ V } \pm 0.25 \text{ V}$
- Pause: $2.5 \text{ V } \pm 0.4 \text{ V}$

(c) Resistors for Adjustment

Mode	Ref. No.	Typical Value
Stop	R466, R464	9.1 k Ω (F), 15 k Ω (F)
Fast (F.F./Rew.)	R463	56 k Ω
Pause	R410	680 k Ω
Play	R411	120 k Ω
Record	R494	150 k Ω

(d) Adjustment Procedures

- 1) Press the Stop button to set the N-480Z in Stop mode. Adjust the value of R466 and R464 to obtain 15 V (± 0.6 V) at the sliding contact of VR601.

Note: When R466 and R464 are adjusted, the reference voltage in Fast (F.F. or Rew.) mode is changed. Therefore, re-check of the reference voltage in Fast (F.F. or Rew.) mode is required. If the reference voltage is out of the range, readjustment of R463 according to next step 2) is necessary.

- 2) Set the N-480Z in F.F. mode, then adjust the value of R463 so that the voltage of VR601 will become lower by 1.5 V (± 0.25 V) than in Stop mode.
- 3) Press the Pause button to set the N-480Z in Pause mode. Adjust the value of R410 to obtain 10 V ($+0.4$, -0.15 V) at the sliding contact of VR601.
- 4) Set the N-480Z in Playback mode, then adjust the value of R411 so that the voltage of VR601 will become lower by 2.5 V (± 0.4 V) than in Pause mode.
- 5) Short both leads of capacitor C417 with a jumper wire. Set the N-480Z in Record mode, then adjust the value of R494 so that the voltage of VR601 will become higher by 1 V ($+0.4$, -0.2 V) than in Stop mode.

Note: Remove the short of C417 after completion of adjustment.

(3) Cam Timing Adjustment

- (a) Remove the wires from the Control Motor terminals to set the motor open.
- (b) Without loading a cassette tape and with pressing the record protecting switch with your finger tip, press

the Record and Play buttons to set the N-480Z in Record mode.

- (c) Turn the Cam and bring the "PY" mark toward the pointer by hand. Reel Motor will rotate before the "PY" mark reaches the pointer. Adjust the value of R452 so that the voltage at the sliding contact of VR601 becomes 9.7 V (± 0.3 V) when Reel Motor starts rotation.
- (d) Observe the mute signal at the Q424 collector. Turn the Cam referring to above step (c) and check to insure that the voltage at the sliding contact of VR601 is 9.5 V (± 0.3 V) when mute is released (mute signal changes from H to L). (This voltage is determined by the adjustment of R452 in above step (c).)
- (e) Observe the (Play + Pause)-Position signal at the Q418 collector. Turn the Cam referring to above step (c) and adjust the value of R445 to obtain 11.2 V (± 0.4 V) at the sliding contact of VR601 when (Play + Pause)-Position signal changes from L to H (bias oscillation will begin).
- (f) Upon completion of above adjustment, re-connect wires to the motor terminals.

4.2. Tape Speed Adjustment

- (1) Remove the Top Cover Ass'y referring to item 2.1.
- (2) Connect a Frequency Counter to the Output Jack.
- (3) Load a 3 kHz Speed Wow/Flutter Tape (DA09006A) and play it back.
- (4) Referring to Fig. 4.3, adjust the Tape Speed Adjustment Volume (VR501) incorporated in the Capstan Motor to obtain 3,000 Hz on the Frequency Counter.
 - CCW: Motor drives slowly.
 - CW: Motor drives fast.

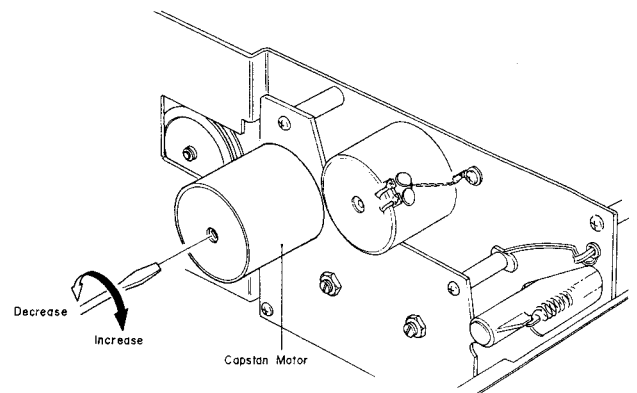

Fig. 4.3

4.3. Record/Playback Head Tilt Adjustment

Note: On items 4.3 – 4.8, refer to Fig. 4.4 flow chart. Refer to Figs. 4.5 and 4.6.

- (1) Load a Tilt Check Gauge M-9036 (DA09036A) in the N-480Z.
- (2) Clip the grounding terminal of the Tilt Check Gauge with one end of the cord with clip, and the chassis of the N-480Z with the other end.
- (3) Remove the Height Gear.
- (4) Set the N-480Z in Play mode. Check to insure whether the Beacon "Upper" or "Lower" is illuminating. In order not to give damages onto the record/playback head surface, push the slide knob of the Gauge to the direction of an arrow mark, then return it to the original place to be in contact with record/playback head surface after Play mode is securely locked.
- (5) Check to insure freedom from contact between the Gauge and pad lifter.
- (6) Beacon "Lower" will light on when height adjustment screw turned clockwise but "Upper" when counterclockwise. Adjust so that both "Upper" and "Lower" will light on even when you move the slide knob to the direction of an arrow mark and then return it to the original place.
- (7) Set the N-480Z in Stop mode and fit the serrated Height Gear. Then set the N-480Z again in Play mode and insure 2 Beacons "Upper" and "Lower" are illuminating.
If not, (3) through (6) will have to be repeated till satisfactory results are obtained.

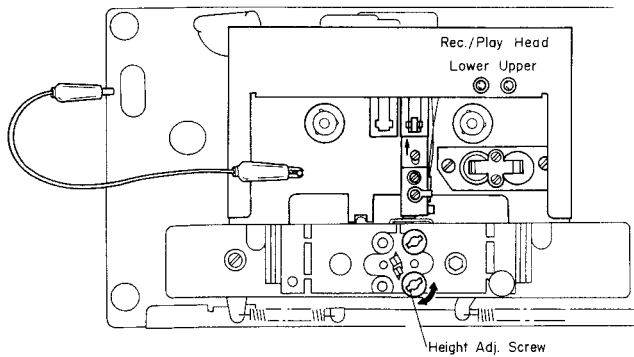

Fig. 4.5

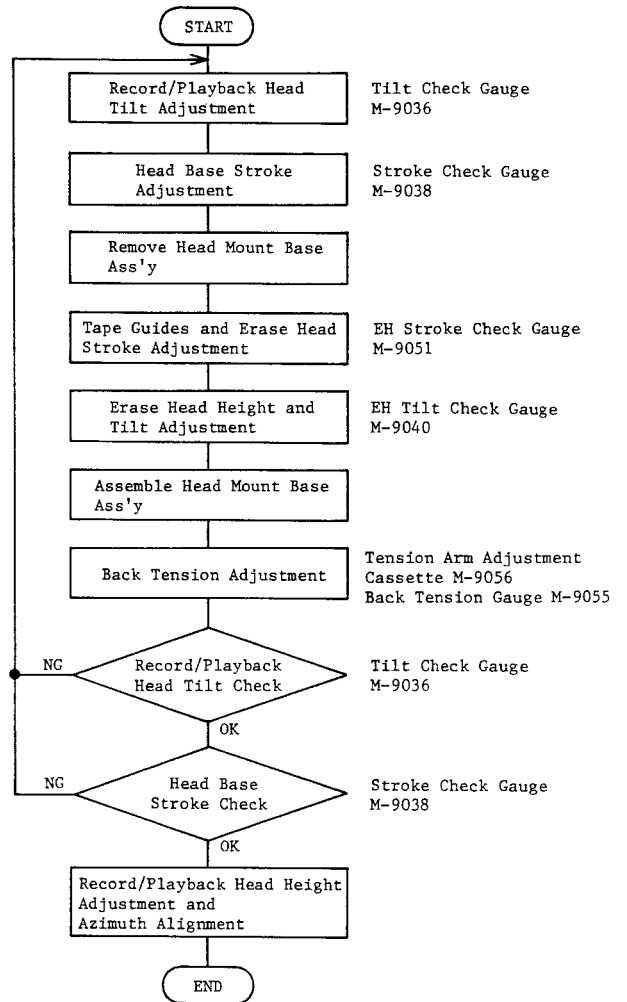

Fig. 4.4

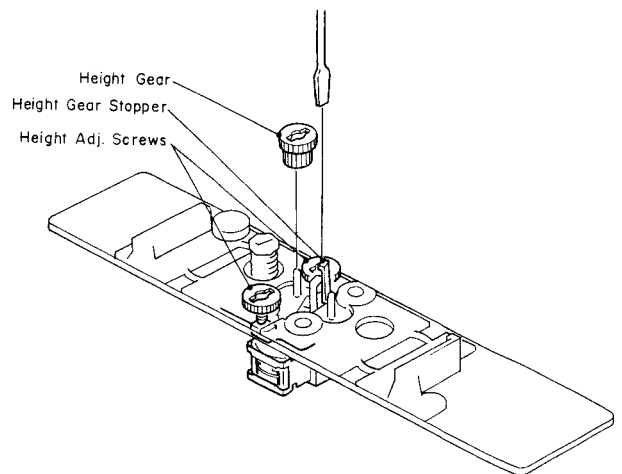

Fig. 4.6

4.4. Head Base Stroke Adjustment

Refer to Fig. 4.7.

Note: Before you conduct "Head Base Stroke Adjustment", adjust with a "Tilt Check Gauge" to insure freedom from tilt on the record/playback head.

- (1) Load a Stroke Check Gauge M-9038 (DA09038A) in the N-480Z.
- (2) Set the N-480Z in Play mode.
- (3) Check to insure whether the "P" pointer on the Stroke Indicator locates between 2 lines as marked on the Stroke Check Plate.
- (4) If the record/playback head stroke is noted to be misaligned, adjustment can be made by moving the stroke adjuster assembled in the head base assembly (either forwardly or backwardly).

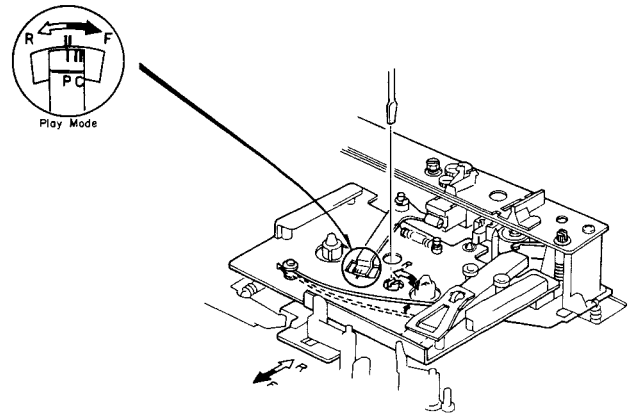

Fig. 4.7

4.5. Tape Guides Adjustment and Erase Head Stroke Adjustment

Remove Head Mount Base Ass'y referring to item 2.22. Refer to Figs. 4.8 and 4.9.

(1) Supply Tape Guide Height Adjustment

- (a) Load an EH Stroke Check Gauge M-9051 (DA0-9051A) in the N-480Z.
- (b) Set the N-480Z in Play mode.
- (c) Slide the Supply Tape Guide Check Bar down against the supply tape guide, thus check can be made on supply tape guide height.
- (d) If the supply tape guide is misaligned, the Supply Tape Guide Check Bar will not come into the supply tape guide. If such is noted, turn to adjust the height adjustment nut A till the Supply Tape Guide Check Bar is accepted by the supply tape guide.
- (e) If the above are insured, set the N-480Z in Pause mode, then in Play mode to see whether adjustments are appropriately made. If not, (b) through (e) will have to be repeated till satisfactory results are obtained.

(2) Take-up Tape Guide Height Adjustment

- (a) Load an EH Stroke Check Gauge M-9051 (DA0-9051A) in the N-480Z.
- (b) Set the N-480Z in Play mode.
- (c) Slide the Take-up Tape Guide Check Bar down against the take-up tape guide, thus check can be made on take-up tape guide height.
- (d) If the take-up tape guide is misaligned, the Take-up Tape Guide Check Bar will not come into the take-up tape guide. If such is noted, turn to adjust the height adjustment nut C till the Take-up Tape Guide Check Bar is accepted by the take-up tape guide.
- (e) If the above are insured, set the N-480Z in Pause mode, then in Play mode to see whether adjustments are appropriately made. If not, (b) through (e) will have to be repeated till satisfactory results are obtained.

(3) Erase Head Stroke Adjustment

- (a) Load an EH Stroke Check Gauge M-9051 (DA0-9051A) in the N-480Z.
- (b) Set the N-480Z in Play mode, thus check can be made on erase head stroke through the EH Stroke Indicator.
- (c) Check to insure whether the erase head surface is aligned with red line on the EH Stroke Indicator. If not, adjust the erase head stroke by loosening 2 screws B that assemble erase head and erase head plate.
- (d) After completion of adjustment, 2 pcs. of screws shall be locked with lock tight paint.

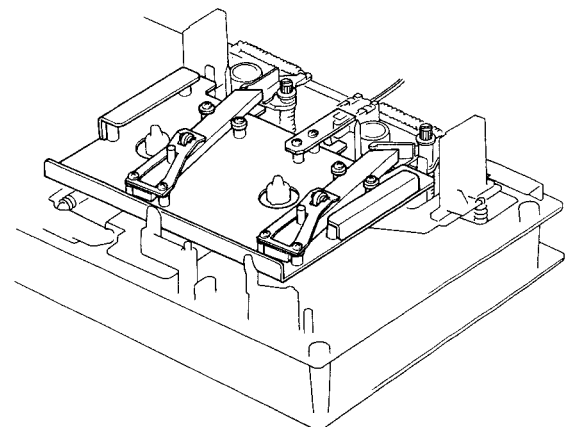

Fig. 4.8

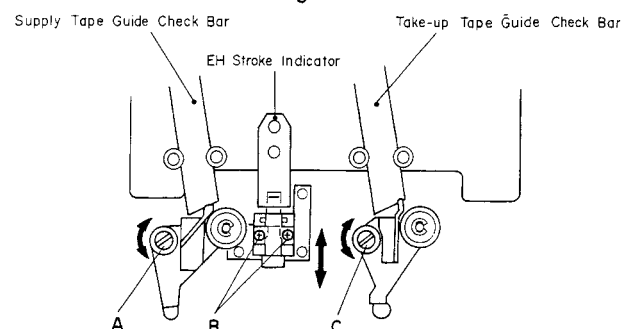

Fig. 4.9

4.6. Erase Head Height and Tilt Adjustment

Refer to Figs. 4.10 and 4.11.

- (1) Remove Head Mount Base Ass'y referring to item 2.22.
- (2) Load an EH Tilt Check Gauge M-9040 (DA09040A) in the N-480Z.
- (3) Set the N-480Z in Stop mode.
- (4) Check to insure whether one of the 3 Beacons is illuminating. Look down the mirror as shown by an arrow mark and slowly turn the Screw "Height" counterclockwise (or clockwise) so that the two horizontal lines on the mirror will become superposed on the line (in different color) of the erase head, and check to insure whether Beacon "1" is illuminating.
- (5) Turn Screw "Tilt" counterclockwise (or clockwise) to light on Beacon "2". Excessive turning will cause the Beacon "1" to light off. Adjustments of Screw "Tilt" will therefore be conducted till both of the Beacons "1" and "2" illuminate.
- (6) Turn Screw "Azimuth" counterclockwise (or clockwise) to light on Beacon "3". Excessive turning will cause either Beacon "1" or "2" to light off, and therefore adjust Screw "Azimuth" until all of the 3 Beacons "1", "2" and "3" illuminate.
- (7) Check to insure whether the horizontal line on the mirror corresponds to that on the erase head. If not, (4) through (7) will have to be repeated till satisfactory results are obtained.
- (8) After completion of adjustment, 3 pcs. of screws shall be locked with lock tight paint.

Note: Before use of this gauge, check to insure freedom from dust or dirt, or overflow in the groove of the erase head surface.

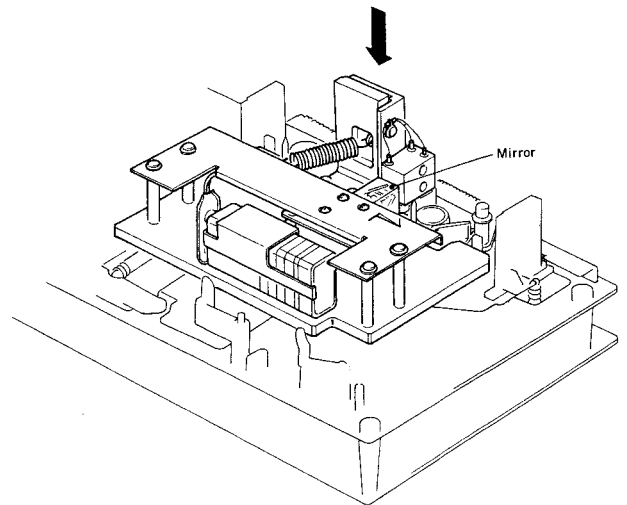

Fig. 4.10

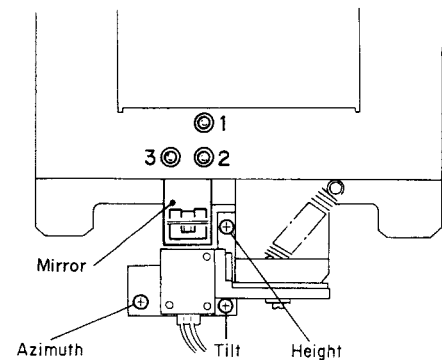

Fig. 4.11

4.7. Back Tension Adjustment

Refer to Figs. 4.12 – 4.14.

- (1) Load a Tension Arm Adjustment Cassette (DA09056A) in the N-480Z referring to Fig. 4.12.
- (2) Set the N-480Z in Play mode.
- (3) Bend the Back Tension Arm with pliers so that the gap between the Cassette Holding Spring assembled on the Head Base Ass'y and the Back Tension Arm becomes 0.5 mm as shown in Fig. 4.13. Do not bend the top of the Back Tension Arm.
- (4) Load the Back Tension Gauge (DA09055A) in the N-480Z.
- (5) Set the N-480Z in Play mode and read the torque value of Back Tension Gauge.

If the value is in a range of 6 g-cm to 10 g-cm, adjustment is not necessary. If not, change the installation point of the Back Tension Spring as shown in Fig. 4.14, and obtain the torque of 7 g-cm to 9 g-cm range.

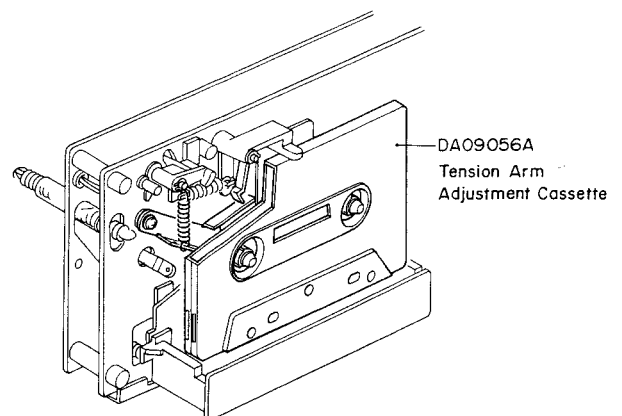

Fig. 4.12

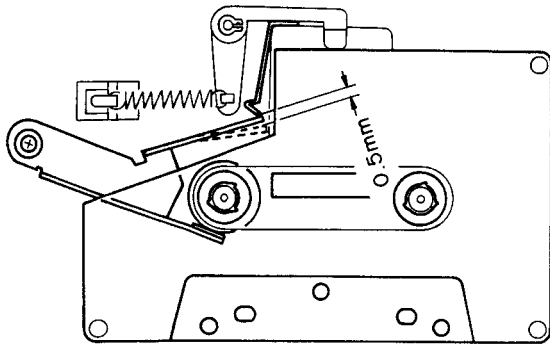

Fig. 4.13

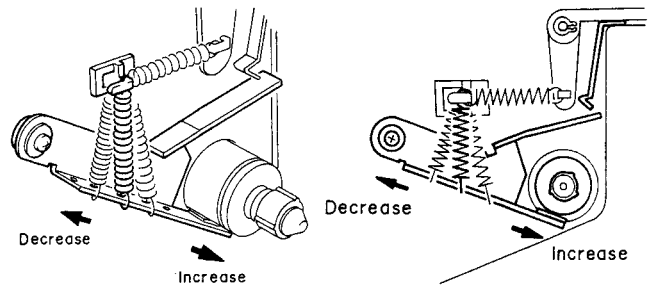

Fig. 4.14

4.8. Record/Playback Head Height Adjustment and Azimuth Alignment

Refer to Fig. 4.15.

- (1) Connect a VTVM to the Output Jacks.
- (2) Load a 1 kHz Track Alignment Tape (DA09007A) in the N-480Z.
- (3) Set the N-480Z in Play mode.
- (4) Turn the Height Gear until the outputs of both channels become minimum.
- (5) Load a 15 kHz Azimuth Tape (DA09004A) in the N-480Z.
- (6) Set the N-480Z in Play mode.
- (7) Turn the Azimuth Alignment Screw until the outputs of both channels become maximum.
- (8) Repeat (2) through (7) one or two times to obtain optimum performance.

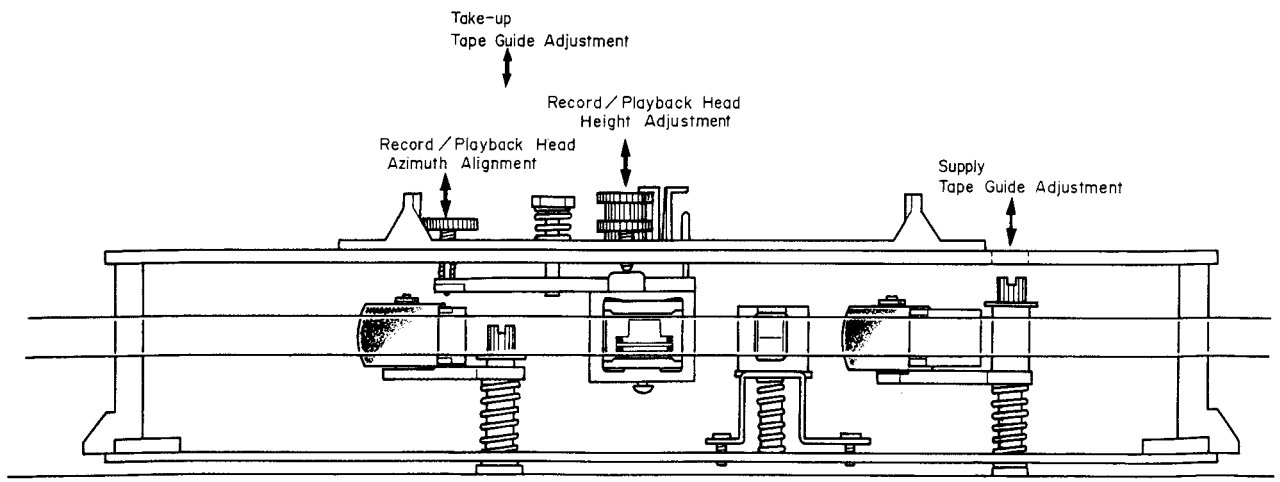

Fig. 4.15

4.9. Tape Travelling Adjustment

The adjustment shall be made with a modified version of the current type EXII C-90 as shown in Fig. 4.16 (error will be made if a previous type Tape Travelling Cassette (DA09011A) should be used for this purpose).

While modifying an EXII C-90, the tape guides in the cassette housing shall be kept protected to avoid tilt. Check shall be made in the following procedures:

- (1) An EXII C-90 tape thus modified shall be loaded onto the N-480Z.
- (2) Release the back-tension (rotate the Supply Reel and feed out some length of tape) and set the N-480Z in Play mode.
- (3) In this juncture, check to insure whether the tape is free from waving or slippage from the tape guide.
- (4) When the modified EXII C-90 is played back, check to insure whether the tape is freedom from waving from head surface or at pressure rollers.
- (5) If either of waving or slippage from the tape guide should be noted, adjustments of "4.3. Record/Playback Head Tilt Adjustment", "4.4. Head Base Stroke Adjustment", "4.5. Tape Guides Adjustment and Erase Head Stroke Adjustment", "4.6. Erase Head Height and Tilt Adjustment", "4.7. Back Tension Adjustment", "4.8. Record/Playback Head Height Adjustment and Azimuth Alignment", etc. will be required.

As a case may be, the said waving or slippage may have been caused from defective supply Pressure Roller Ass'y or Take-up Pressure Roller Ass'y without parallel contact with capstans. If such are noted, the Pressure Roller Assemblies will have to be replaced.

Further, excessively weak take-up torque or strong take-up torque may cause defective tape travelling.

The N-480Z is intended to be an adjustment-free Model, however if the similar matters as above should be noted, please replace the Reel Hub Ass'y to obtain appropriate take-up torque.

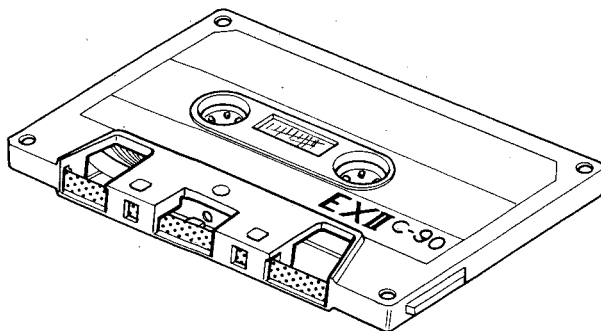

Fig. 4.16

4.10. Record Switch Linkage Adjustment

- (1) Set the N-480Z in Stop mode.
- (2) Loosen the screw of the Record Spring Holder, and shift the Record Spring Holder in order to remove the looseness of the Linkage Wire as shown in Fig. 4.17. Then tighten the screws for fixing the Record Spring Holder. (In this case, the Record Switch should be positioned at play side. If on the record position, it will be defective.)
- (3) Set the N-480Z in Record and Pause mode. Check to insure that the gap between the top of the wire and the Record Spring Holder is approx. 1 mm as shown in Fig. 4.18. (Check that the Record Switch is in record position.)
- (4) Upon completion of the above adjustments, apply a quantity of lock tight paint.

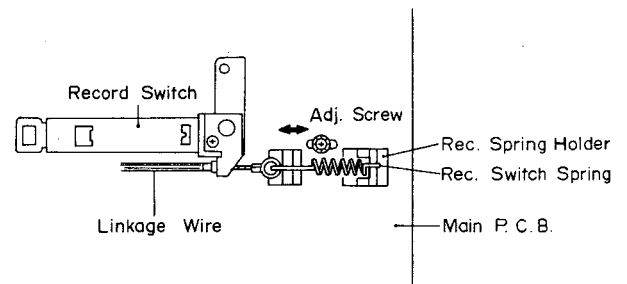

Fig. 4.17

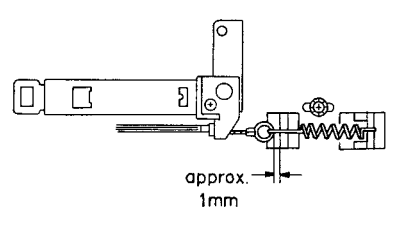

Fig. 4.18

4.11. Flywheel Holder Adjustment

(1) Refer to Fig. 4.19.

Tighten the Thrust Screws until the gap between the Flywheel Assemblies and Thrust Screws becomes minimized when both of the Capstan Shafts are moved backwardly and forwardly (the Thrust Springs between the Capstan Flanges and Flywheel Thrust Caps are in a flat state).

Excessive tightening of the Thrust Screws however will give damages on the Flywheel Assemblies, to which careful attention is invited.

- (2) Return the Thrust Screws by 1/2 turn.
- (3) Fixing the Thrust Screws with a screwdriver, lock the Lock Nut.
- (4) Apply a quantity of lock tight paint to the Thrust Screws.

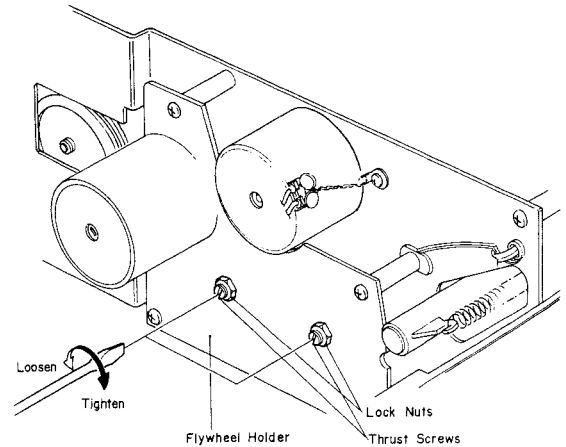

Fig. 4.19

4.12. Eject Wire Adjustment

- (1) Referring to Fig. 4.20, insert a 1.5 mm spacer between the Eject Arm and Eject Stopper by turning the Eject Arm in the illustrated direction, then set the N-480Z in Playback mode.
- (2) With pushing the Eject Arm by hand, loosen the screw and then pull the Eject Wire in the direction of the arrow until it stops as shown in Fig. 4.21.
- (3) Tighten the screw, then apply a quantity of lock tight paint.

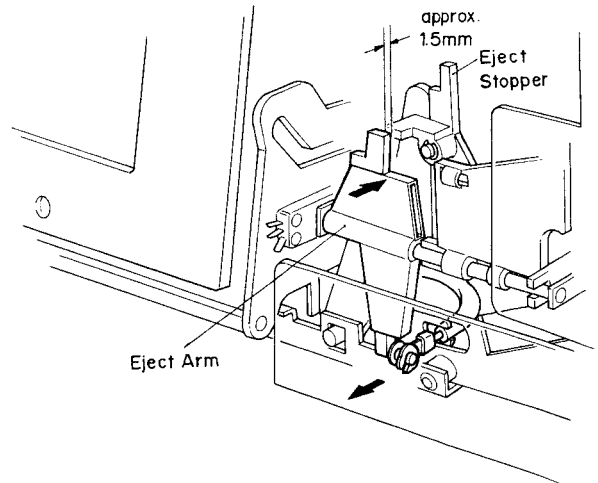

Fig. 4.20

4.13. Lubrication

N-480Z is a lubrication-free cassette deck except when parts are replaced. Apply the following lubricant for each replaced part:

- (1) LAUNA #100
 - Capstan Shaft
 - Pressure Roller Shaft
 - Thrust Cap
- (2) FLOIL GB-TS-1
 - Reel Hub Shaft
 - Thrust portion on the Capstan Shaft

FLOIL GB-TS-1, made by Kanto Chemicals Co., Ltd. in Japan.

We suggest that you use the above or equivalent type. If unavailable please contact Kanto Chemicals Co., Ltd., 2-7 Kanda Suda-cho Chiyoda-ku, Tokyo 101 Japan.
- (3) Silicon Oil #3000 CST
 - Air Damper Piston

Note: Excessive lubrication may cause defective damper action as the 0.2 ϕ hole at the end of the cylinder may be filled with oil.

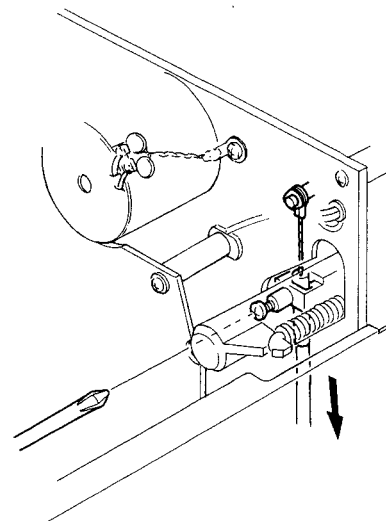

Fig. 4.21

5. PARTS LOCATION FOR ELECTRICAL ADJUSTMENT

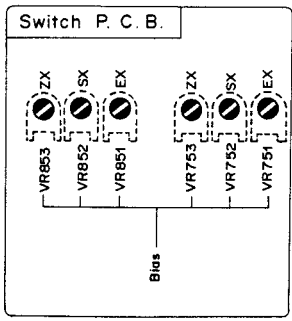
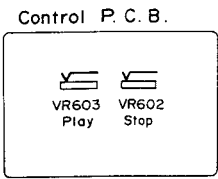
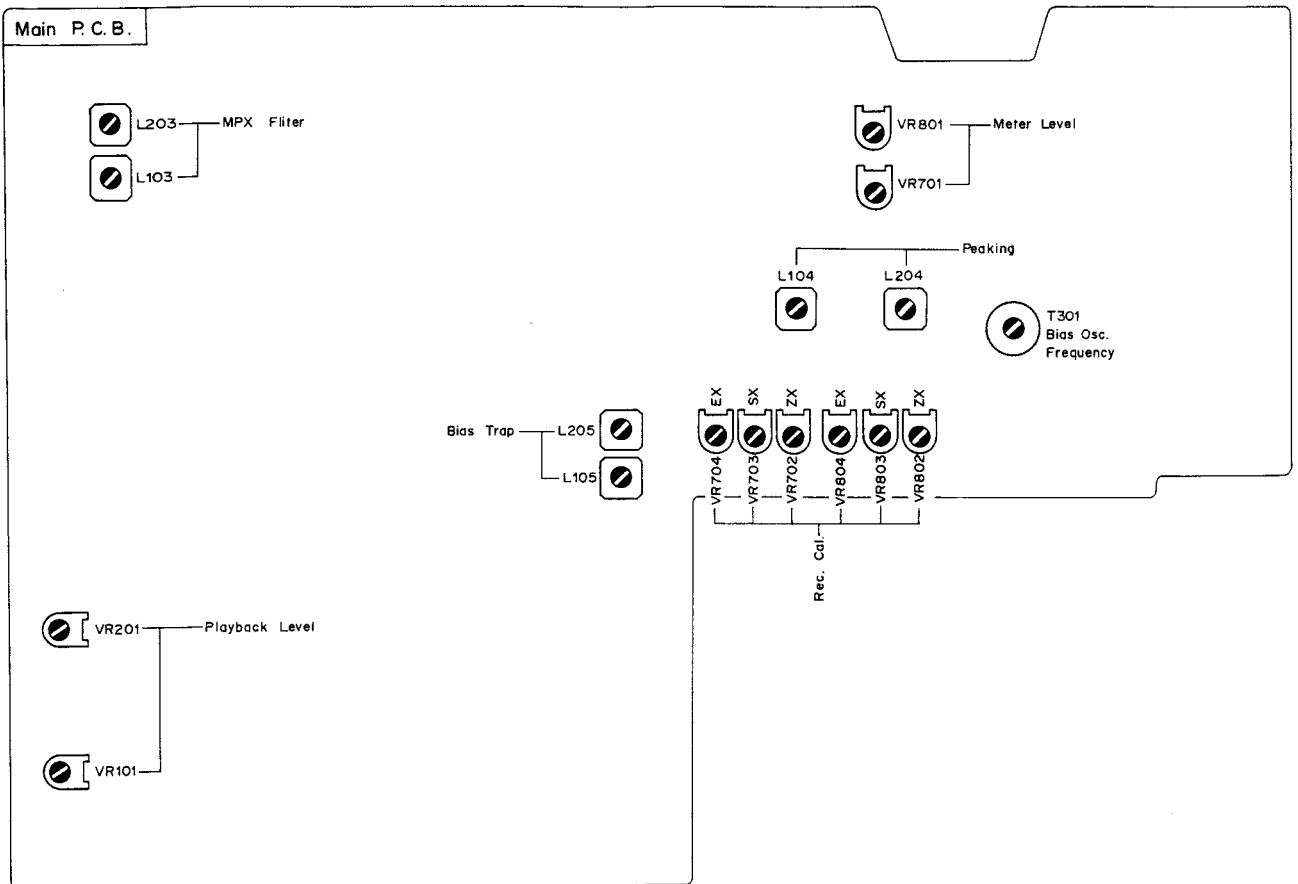

Fig. 5

6. ELECTRICAL ADJUSTMENTS AND MEASUREMENTS

6.1. Adjustment and Measurement Instructions

Note: Electrical adjustment should be performed after mechanical adjustment is completed.

STEP	ITEM	SIGNAL SOURCE	OUTPUT CONNECTION	MODE	ADJUSTMENT	REMARKS
1	Tape Speed Adjustment	3 kHz Speed and Wow/Flutter Tape (DA09006A)	Frequency Counter to Output Jacks	Playback Eq. SW – 70 μ s	Capstan Motor Governor P.C.B. VR501	Adjust VR501 to obtain 3 kHz \pm 0.5%. (VR501 is incorporated in the capstan motor.)
2	Meter Level Calibration	400 Hz to Input Jacks	VTVM to TP101, TP201 on Main P.C.B.	Record, Pause	Main P.C.B. VR701, VR801	1. Feed in 400 Hz, then adjust the Input Level controls to obtain 90 mV -0.4 dB on the VTVM. 2. Adjust VR701 (VR801) so that the 0 dB segment of the level meter starts illuminating. 3. Adjust the Input Level controls to obtain 90 mV on the VTVM, then decrease the generator output level by 20 dB. 4. Check to insure that the segment for -20 dB illuminates.
3	MPX Filter Adjustment	19 kHz \pm 100 Hz to Input Jacks	VTVM to Output Jacks	Record, Pause MPX SW – OUT/IN	Main P.C.B. L103, L203	1. Adjust the Input Level controls to obtain 600 mV on the VTVM. 2. Set the MPX Filter switch to IN, then adjust L103 (L203) to obtain the minimum reading on the VTVM (minimum reading will be less than -30 dB).
4	Record/Playback Head Track Alignment	1 kHz Track Alignment Tape (DA09007A)	VTVM to Output Jacks	Playback ZX SW – OUT SX/EX SW – SX Eq. SW – 70 μ s Dolby NR SW – OFF MPX SW – OUT	Height Gear	Adjust the Height Gear to obtain minimum readings of both channels on the VTVM. Refer to "Record/Playback Head Height Adjustment and Azimuth Alignment" in item 4.8.
5	Record/Playback Head Azimuth Alignment	15 kHz Azimuth Tape (DA09004A)	VTVM to Output Jacks	Same as above	Record/Playback Head Azimuth Alignment Screw	Adjust the Record/Playback Head Azimuth Alignment Screw to obtain maximum readings of both channels on the VTVM. Refer to "Record/Playback Head Height Adjustment and Azimuth Alignment" in item 4.8. Note: Repeat steps 4 and 5 one or two times to obtain optimum performance.
6	Playback Level Calibration	400 Hz Level Tape (DA09005A)	VTVM to TP101, TP201 on Main P.C.B.	Same as above	Main P.C.B. VR101, VR201	Adjust VR101 (VR201) to obtain 90 mV on the VTVM.
7	Playback Frequency Response Adjustment	400 Hz Level Tape (DA09005A) 10 kHz PB Frequency Tape (DA09003A) 15 kHz PB Frequency Tape (DA09002A) 20 kHz PB Frequency Tape (DA09001A)	VTVM to Output Jacks	Same as above	Main P.C.B. R111, R211 R110, R210	1. Load a 400 Hz level tape and play it back. 2. Load 10 kHz, 15 kHz and 20 kHz PB frequency response tapes and adjust the record/playback head azimuth to obtain maximum levels on the VTVM with each tape. 3. Read the maximum levels with each tape and check to insure that the levels against the 400 Hz level tape are within the following ranges. If not, obtain satisfactory results by shorting R111 (R211) or R110 (R210). 10 kHz (-20 dB) 0 dB to $+2$ dB 15 kHz (-20 dB) 0 dB to $+3$ dB 20 kHz (-20 dB) 0 dB to $+4$ dB Check to insure that the difference in level between 10 kHz (-20 dB) and 20 kHz (-20 dB) is less than 2 dB. 4. Conduct step 5 "Record/Playback Head Azimuth Alignment". 5. If above is not sufficient, refer to "Playback Frequency Response Adjustment" in item 6.2.

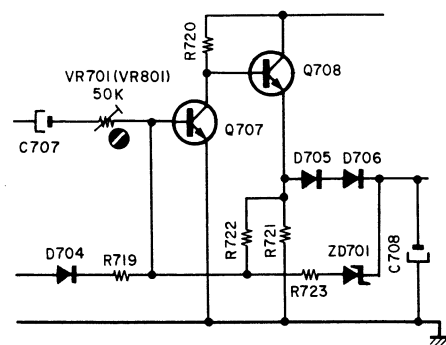

Fig. 6.1
2. Meter Level

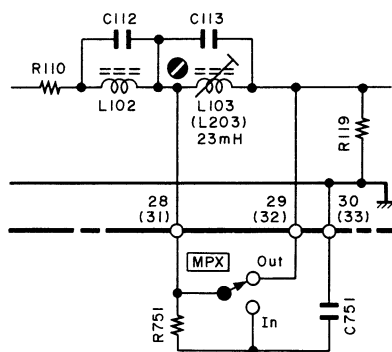

Fig. 6.2
3. MPX Filter

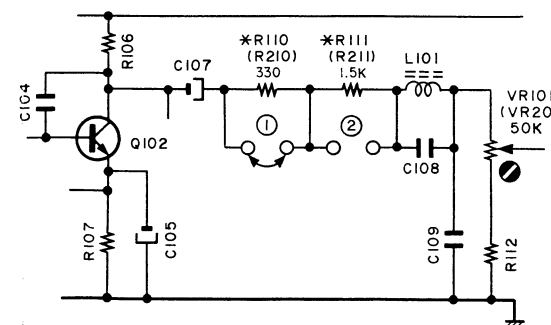

Fig. 6.3
6. Playback Level
7. Playback Frequency Response

STEP	ITEM	SIGNAL SOURCE	OUTPUT CONNECTION	MODE	ADJUSTMENT	REMARKS
8	Bias Oscillation Frequency and Erase Current Adjustment	External 0.1 Ω Resistor in series to Erase Head	VTVM and Frequency Counter across the 0.1 Ω Resistor	Record, Pause ZX SW – IN Eq. SW – 70 μ s Dolby NR SW – OFF MPX SW – OUT	Main P.C.B. T301 R307, R308	<ol style="list-style-type: none"> 1. Set the Bias Tune Volume to center position. 2. Adjust T301 to obtain 105 kHz on the frequency counter. 3. Check the erase current by the VTVM. Erase current will be in a range of 310 mA to 400 mA (typically approx. 350 mA). If erase current is not sufficient, increase it by shorting R307 or R308. 4. After completion of the erase current adjustment, re-check the bias oscillation frequency.
9	Record Amplifier Equalizer Adjustment	21 kHz (–20 dB) to Input Jacks	VTVM to CN3-1, CN3-3 on Main P.C.B.	Same as above	Main P.C.B. L104, L204	<ol style="list-style-type: none"> 1. Remove the bias-cut-jumper from the dip side of the Main P.C.B. 2. Adjust L104 (L204) to obtain peak reading at 21 kHz on the VTVM. 3. Re-solder the bias-cut-jumper.
10	Bias Trap Adjustment	Remove input signals	Same as above	Same as above	Main P.C.B. L105, L205	<ol style="list-style-type: none"> 1. Set the Bias Tune Volume to center position. 2. Adjust L105 (L205) to obtain the maximum reading on the VTVM.
11	Record Level Calibration and Recording Bias Current Adjustment	400 Hz (0 dB), 400 Hz (–20 dB), 10 kHz (–20 dB) and 18 kHz (–20 dB) to Input Jacks	VTVM to TP101, TP201 on Main P.C.B. and VTVM to CN3-1, CN3-3 on Main P.C.B. and VTVM and Distortion Meter to Output Jacks	Record and Playback: ZX SW – IN/OUT SX/EX SW – SX/EX Eq. SW – 70 μ s (ZX/SX) 120 μ s (EX) Dolby NR SW – ON, C-Type/ B-Type/ OFF MPX SW – OUT	Main P.C.B. (Record Level) ZX: VR702, VR802 SX: VR703, VR803 EX: VR704, VR804 Switch P.C.B. (Bias Current) ZX: VR753, VR853 SX: VR752, VR852 EX: VR751, VR851	<p>Adjustment should be made in the order of ZX, SX and EX.</p> <ol style="list-style-type: none"> 1. Set the Bias Tune Volume to center position. 2. Set the Dolby NR switch to C-Type. 3. Connect the VTVM to TP101 (TP201) on the Main P.C.B. 4. Set the N-480Z in Record/Pause mode. 5. Feed in 400 Hz, then adjust the Input Level controls to obtain 90 mV (0 dB) on the VTVM. 6. Load a reference ZX tape (DA09037A), reference SX tape (DA09025A) and reference EXII tape (DA09066A). 7. Adjust Record Cal. VR702 (VR802) for ZX, VR703 (VR803) for SX and VR704 (VR804) for EXII to center position. 8. Connect the VTVM to CN3-1 (CN3-3) on the Main P.C.B. Adjust Bias VR753 (VR853) for ZX, VR752 (VR852) for SX and VR751 (VR851) for EXII to obtain the following bias current in Record/Pause mode (the VTVM is connected across a 10-ohm resistor). ZX: approx. 1 mA SX: approx. 0.6 mA EXII: approx. 0.3 mA 9. Connect the VTVM to the Output Jacks. 10. Feed in 400 Hz (–20 dB) and 18 kHz (–20 dB), then record, rewind and play them back. Adjust Bias VR753 (VR853) for ZX, VR752 (VR852) for SX and VR751 (VR851) for EXII to obtain the same playback levels at 400 Hz (–20 dB) and 18 kHz (–20 dB) on the VTVM. 11. Feed in 400 Hz (0 dB), then record, rewind and play it back. Adjust Record Cal. VR702 (VR802) for ZX, VR703 (VR803) for SX and VR704 (VR804) for EXII to obtain 0 dB on the VTVM. 12. Repeat above 10 and 11 two or three times to obtain optimum performance. 13. Set the Dolby NR switch to OFF. 14. Feed in 400 Hz (–20 dB), 10 kHz (–20 dB) and 18 kHz (–20 dB), then record, rewind and play them back. Check to insure that the playback levels are within –20 dB \pm3 dB against the levels in Dolby NR C-Type. 15. Set the Dolby NR switch to B-Type. 16. Feed in 10 kHz (–20 dB) and 18 kHz (–20 dB), then record, rewind and play them back. Check to insure that the levels are within –20 dB \pm2 dB against the levels in Dolby NR OFF. 17. Check to insure whether the total harmonic distortion is less than 1.0% for ZX tape and 1.2% for SX and EXII tapes. 18. If above is not sufficient, repeat 10 to 17 till satisfactory results are obtained.

STEP	ITEM	SIGNAL SOURCE	OUTPUT CONNECTION	MODE	ADJUSTMENT	REMARKS
12	Overall Frequency Response Adjustment	400 Hz (0 dB) and 20 Hz to 18 kHz (-20 dB) to Input Jacks	VTVM to Output Jacks	Record and Playback ZX SW - IN/OUT SX/EX SW - SX/EX Eq. SW - 70 μs (ZX/SX) 120 μs (EX) Dolby NR SW - OFF MPX SW - OUT	Main P.C.B. L104, L204	<ol style="list-style-type: none"> 1. Set the Bias Tune Volume to center position. 2. Set the N-480Z in Record/Pause mode. 3. Feed in 400 Hz, then set the Input Level controls to obtain 0 dB (600 mV) on the VTVM. 4. Decrease the generator output control by 20 dB. 5. Feed in 20 Hz to 18 kHz (-20 dB) and record and play it back, then check to insure whether the output levels are within -20 dB ±4 dB. 6. If above is not sufficient, adjust L104 (L204) to obtain approx. -20 dB on the VTVM, then conduct step 13 "Record Level Calibration and Recording Bias Current Adjustment". 7. If above is not sufficient, precise re-adjustment of step 7 "Playback Frequency Response", replacement of Record/Playback Head or check on item 4.9 "Tape Travelling Adjustment" will be required.
13	Crosstalk Measurement	1 kHz to Input Jacks	1 kHz Band Pass Filter and VTVM to Output Jacks	Record and Playback ZX SW - OUT SX/EX SW - SX Eq. SW - 70 μs Dolby NR SW - OFF MPX SW - OUT		<ol style="list-style-type: none"> 1. Set the Bias Tune Volume to center position. 2. Erase the tape with bulk eraser. 3. Adjust the Input Level controls to obtain 0 dB on the VTVM, and record the signals on the reference SX tape (DA09025A). 4. Turn the cassette tape the other way round and play it back. 5. Measure the difference between 3 and 4.
14	Channel Separation Measurement	1 kHz to Input Jacks	Same as above	Same as above		<ol style="list-style-type: none"> 1. Set the Bias Tune Volume to center position. 2. Erase the tape with bulk eraser. 3. Adjust L ch (R ch) Input Level control to obtain 0 dB on the VTVM, and close R ch (L ch) Input Level control. 4. Record and play it back, then measure the R ch (L ch) level.
15	Erase Measurement	100 Hz to Input Jacks	100 Hz Band Pass Filter and VTVM to Output Jacks	Record and Playback ZX SW - IN Eq. SW - 70 μs Dolby NR SW - OFF MPX SW - OUT		<ol style="list-style-type: none"> 1. Set the Bias Tune Volume to center position. 2. Erase the Tape with bulk eraser. 3. Adjust the Input Level controls to obtain 0 dB on the VTVM, and record the signals on the reference ZX tape (DA09037A). 4. Rewind the tape, close Input Level controls, and then record again. 5. Rewind the tape, play it back, and then measure the difference between 3 and 4.

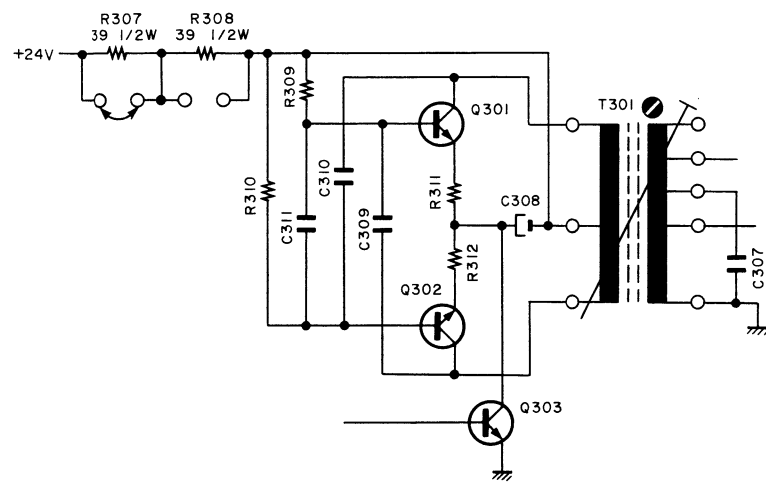

Fig. 6.4
8. Bias Oscillation Frequency and Erase Current

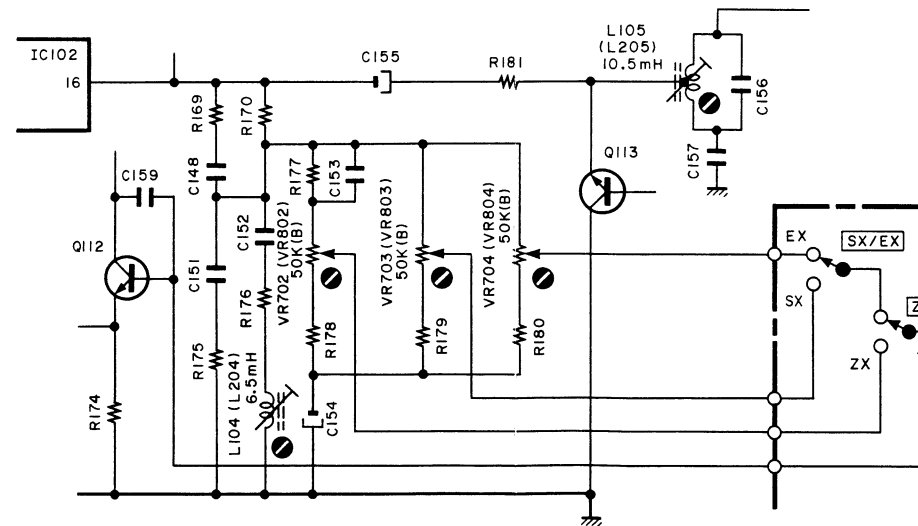

Fig. 6.5
9. Record Amplifier Equalizer
10. Bias Trap
11. Record Level
12. Overall Frequency Response

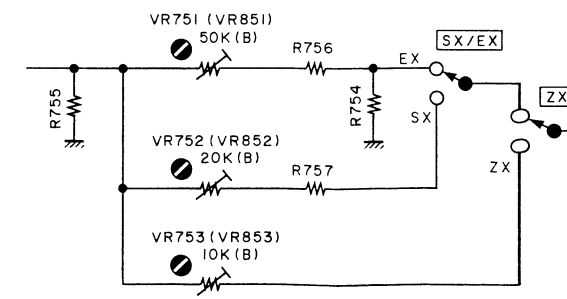

Fig. 6.6
11. Recording Bias Current

STEP	ITEM	SIGNAL SOURCE	OUTPUT CONNECTION	MODE	ADJUSTMENT	REMARKS
16	Signal to Noise Ratio Measurement	400 Hz to Input Jacks	IHF-A Curve Filter, Distortion Meter and VTVM to Output Jacks	Record and Playback ZX SW – IN Eq. SW – 70 μ s Dolby NR SW – ON B-Type/C-Type MPX SW – OUT		<ol style="list-style-type: none"> 1. Set the Bias Tune Volume to center position. 2. Set the Dolby NR switch to B-Type/C-Type. 3. Feed in 400 Hz and record, and play it back. 4. Adjust the Input Level controls to obtain 3% total harmonic distortion in playback mode. 5. Close the Input Level controls then record. 6. After rewind, play back and check the output level difference between 4 and 5. <p>Note: The filter of IHF-A curve shall be used in the measurements.</p>
17	Total Harmonic Distortion Measurement	400 Hz to Input Jacks	VTVM and Distortion Meter to Output Jacks	Record and Playback ZX SW – IN/OUT SX/EX SW – SX/EX Eq. SW – 70 μ s (ZX, SX) 120 μ s (EX) Dolby NR SW – OFF MPX SW – OUT		<ol style="list-style-type: none"> 1. Set the Bias Tune Volume to center position. 2. Adjust the Input Level controls to obtain 0 dB on the VTVM. 3. Record and play it back. 4. Read the distortion meter and check to insure that the distortion is as follows: EXII 1.2% or less SX 1.2% or less ZX 1.0% or less
18	Wow/Flutter Measurement	3 kHz Speed and Wow/Flutter Tape (DA09006A)	Wow/Flutter Meter to Output Jacks	Playback Eq. SW – 70 μ s		Play back and read the wow/flutter meter.

6.2. Playback Frequency Response Adjustment

Fig. 6.7 shows a playback equalization curve and Fig. 6.8 is the playback amp. circuit for adjustment.

(1) Level Adjustment (for middle frequency response)

This adjustment will be required if playback level is not sufficient when 10 kHz PB frequency response tape is played back as referred to step 7 in 6.1 "Adjustment and Measurement Instructions".

Playback equalization level is varied by the modification of R108 (R208) and R109 (R209) on the Main P.C.B.

Following are the details for level modifications:

- Approx. +1 dB R108 (R208): 4.3K
R109 (R209): 3.0K
- 0 dB R108 (R208): 3.9K
R109 (R209): 2.7K
- Approx. -1 dB R108 (R208): 3.6K
R109 (R209): 2.4K

(2) Peaking Adjustment (for high frequency response)

This adjustment will be required if playback level is not sufficient when 20 kHz PB frequency response tape is played back as referred to step 7 in 6.1 "Adjustment and Measurement Instructions".

Peaking portion compensates the gap loss of the playback head. Peaking level is varied by the short circuit of R110 (R210) or R111 (R211) as illustrated in Fig. 6.7.

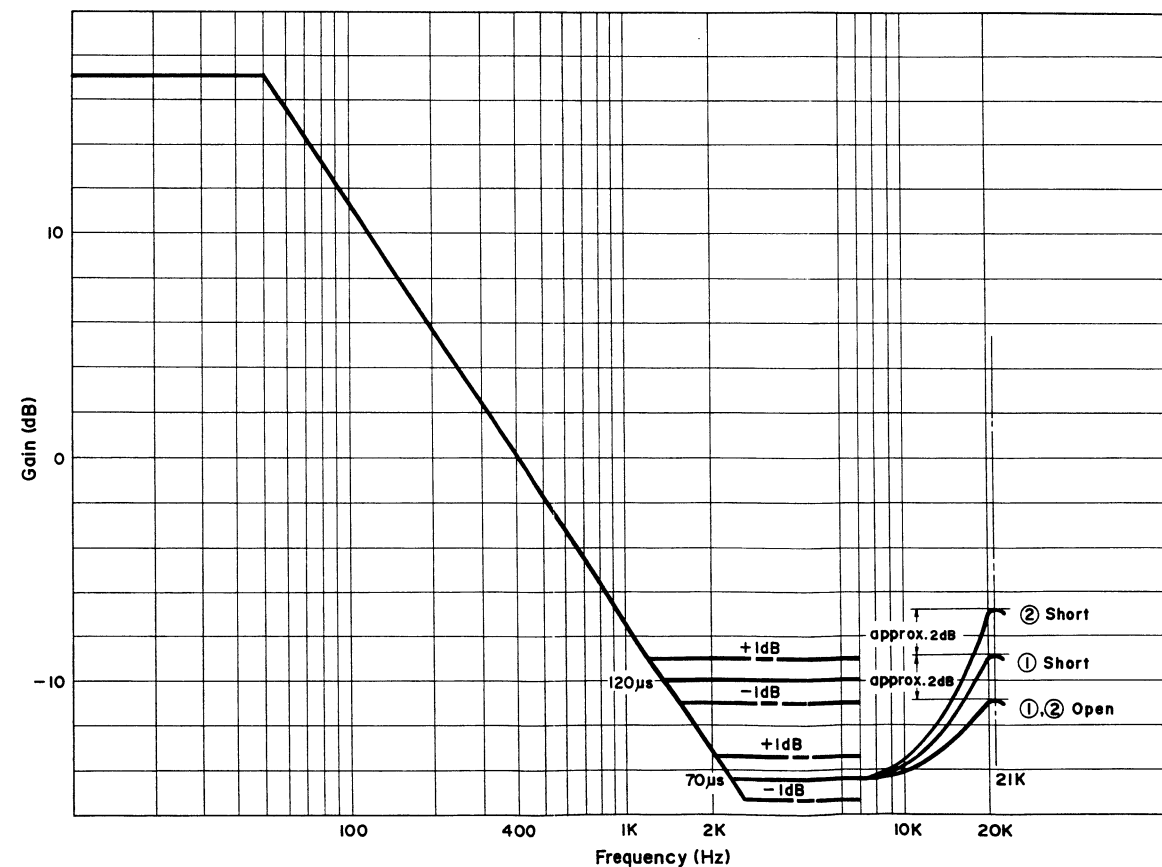

Fig. 6.7 Playback Equalization Curve

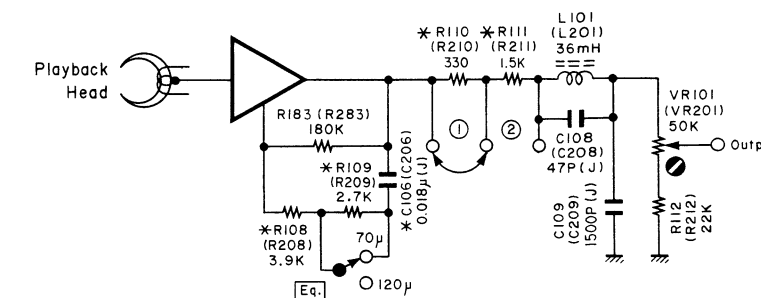

Fig. 6.8 Playback Amp.

6.3. Dolby NR Circuit Check

Dolby NR circuit incorporates a Dolby NR IC (μ A7300-PC) which has no adjustment point.

Perform the following checks and make sure that the IC operates accurately, i.e. accuracy of frequency response through IC.

6.3.1. Dolby NR B-Type Circuit Check

(1) Playback Dolby NR Circuit

Signal Source: 1.4 kHz to negative side of C115 (C215) on Main P.C.B. (Positive side is connected to IC101-9 (IC201-9)).

Output Connection: VTVM to test point TP101 (TP201) on Main P.C.B.

Mode: Stop
Dolby NR SW – ON, B-Type/
OFF

- (a) Connect a VTVM to TP101 (TP201) on the Main P.C.B.
- (b) Set the Dolby NR switch to B-Type. Feed in 1.4 kHz and adjust the generator output control to obtain 9 mV on the VTVM.
- (c) Set the Dolby NR switch to OFF. Check to insure that the reading is +3.2 dB \pm 1.5 dB on the VTVM.

(2) Record Dolby NR Circuit

Signal Source: 1.4 kHz to Input Jacks
Output Connection: VTVM to test point TP101 (TP201) and IC102-14 (IC202-14) on Main P.C.B.

Mode: Record/Pause
Dolby NR SW – ON, B-Type/
OFF

- (a) Connect a VTVM to TP101 (TP201) on the Main P.C.B.
- (b) Feed in 1.4 kHz and adjust the Input level controls to obtain 9 mV/2.85 mV on the VTVM.
- (c) Remove the VTVM from TP101 (TP201) and reconnect it to IC102-14 (IC202-14).
- (d) Check to insure that the reading at IC102-14 (IC202-14) corresponds to the following with Dolby NR switch OFF and B-Type.

Input Level at TP101 (TP201)	Level at IC102-14 (IC202-14)	
	Dolby NR OFF	Dolby NR B-Type
9 mV	0 dB	+3.2 dB \pm 1.5 dB
2.85 mV	0 dB	+8.2 dB \pm 1.5 dB

6.3.2. Dolby NR C-Type Circuit Check

(1) Playback Dolby NR Circuit

Signal Source: 1.4 kHz to negative side of C115 (C215) on Main P.C.B. (Positive side is connected to IC101-9 (IC201-9)).

Output Connection: VTVM to test point TP101 (TP201) on Main P.C.B.

Mode: Stop
Dolby NR SW – ON, C-Type/
OFF

- (a) Connect a VTVM to TP101 (TP201) on the Main P.C.B.
- (b) Set the Dolby NR switch to C-Type. Feed in 1.4 kHz and adjust the generator output control to obtain 9 mV on the VTVM.
- (c) Set the Dolby NR switch to OFF. Check to insure that the reading is +6.5 dB \pm 1.5 dB on the VTVM.

(2) Record Dolby NR Circuit

Signal Source: 1.4 kHz to Input Jacks
Output Connection: VTVM to test point TP101 (TP201) and IC102-14 (IC202-14) on Main P.C.B.

Mode: Record/Pause
Dolby NR SW – ON, C-Type/
OFF

- (a) Connect a VTVM to TP101 (TP201) on the Main P.C.B.
- (b) Feed in 1.4 kHz and adjust the Input level controls to obtain 9 mV/2.85 mV on the VTVM.
- (c) Remove the VTVM from TP101 (TP201) and reconnect it to IC102-14 (IC202-14).
- (d) Check to insure that the reading at IC102-14 (IC202-14) corresponds to the following with Dolby NR switch OFF and C-Type.

Input Level at TP101 (TP201)	Level at IC102-14 (IC202-14)	
	Dolby NR OFF	Dolby NR C-Type
9 mV	0 dB	+6.5 dB \pm 1.5 dB
2.85 mV	0 dB	+11.4 dB \pm 1.5 dB

7. MOUNTING DIAGRAMS AND PARTS LIST

Note: Mounting diagram shows a dip side view of the printed circuit board.

7.1. Main P.C.B. Ass'y

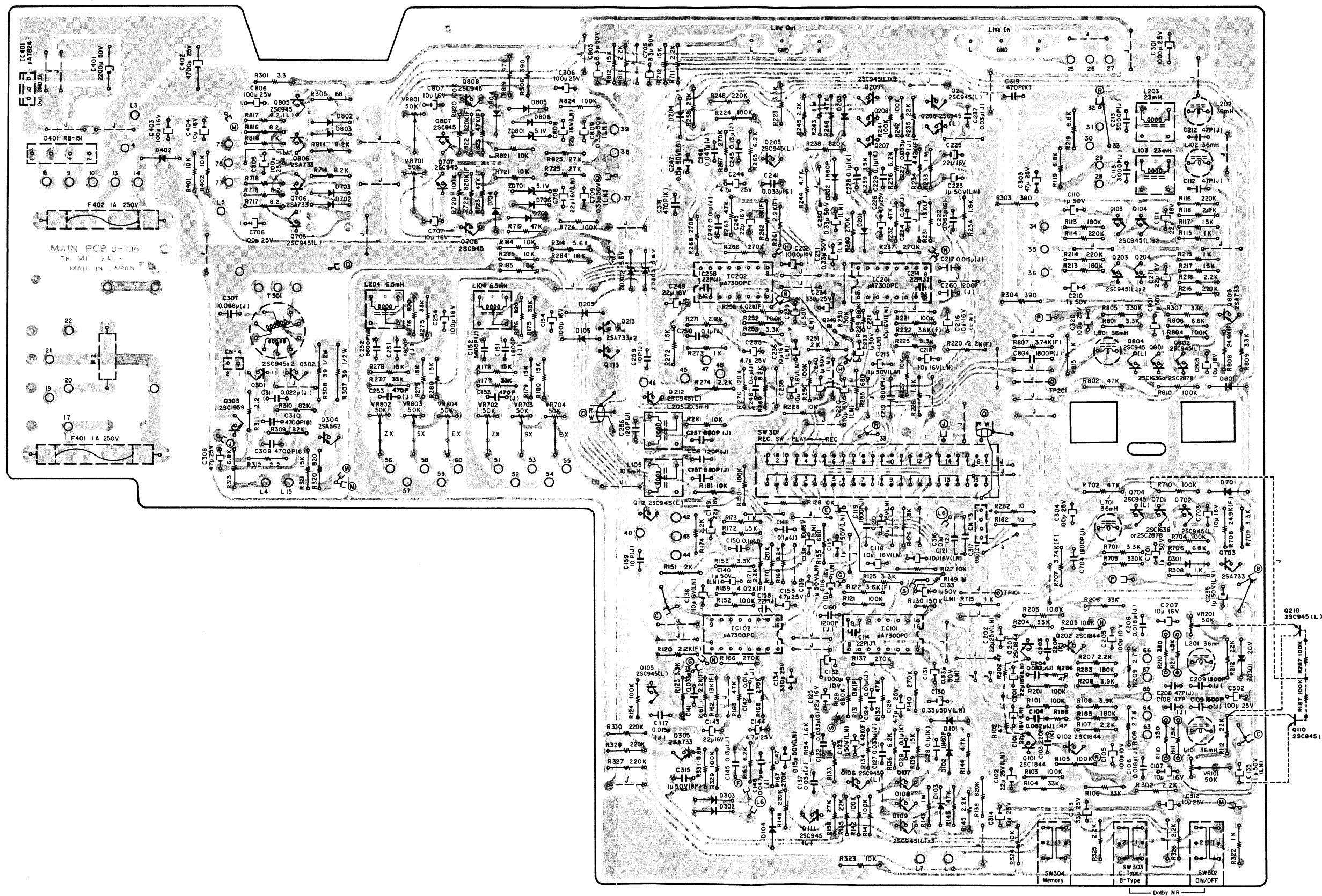

Fig. 7.1.1 Serial No.: A30811680 –
Serial No.: A30910200 –

Note: Diode is 1SS53 unless otherwise specified.

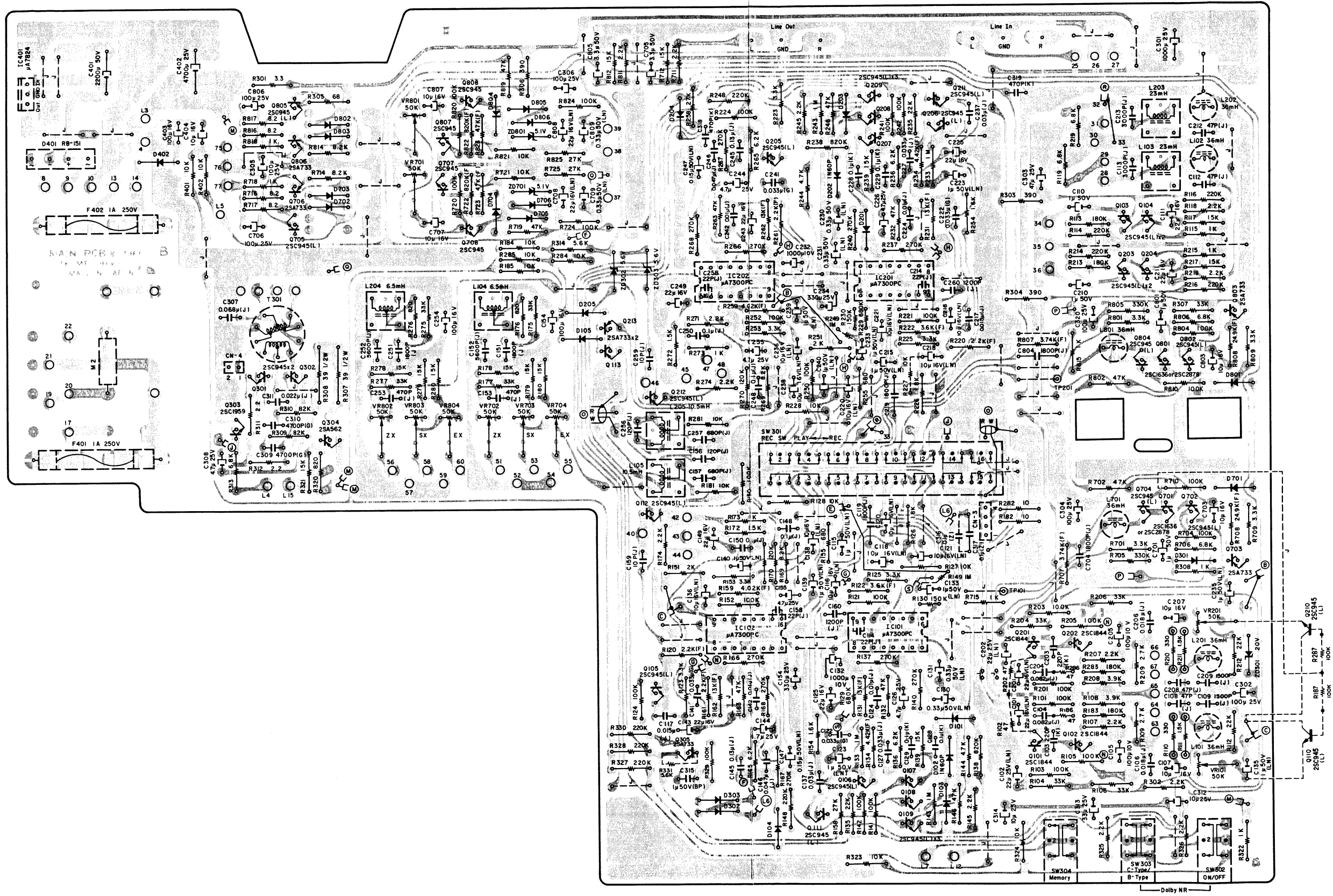

Fig. 7.1.2 Serial Nos.: A30805969 – A30811679
 Serial Nos.: A30902974 – A30910199

Note: Diode is 1SS53 unless otherwise specified.

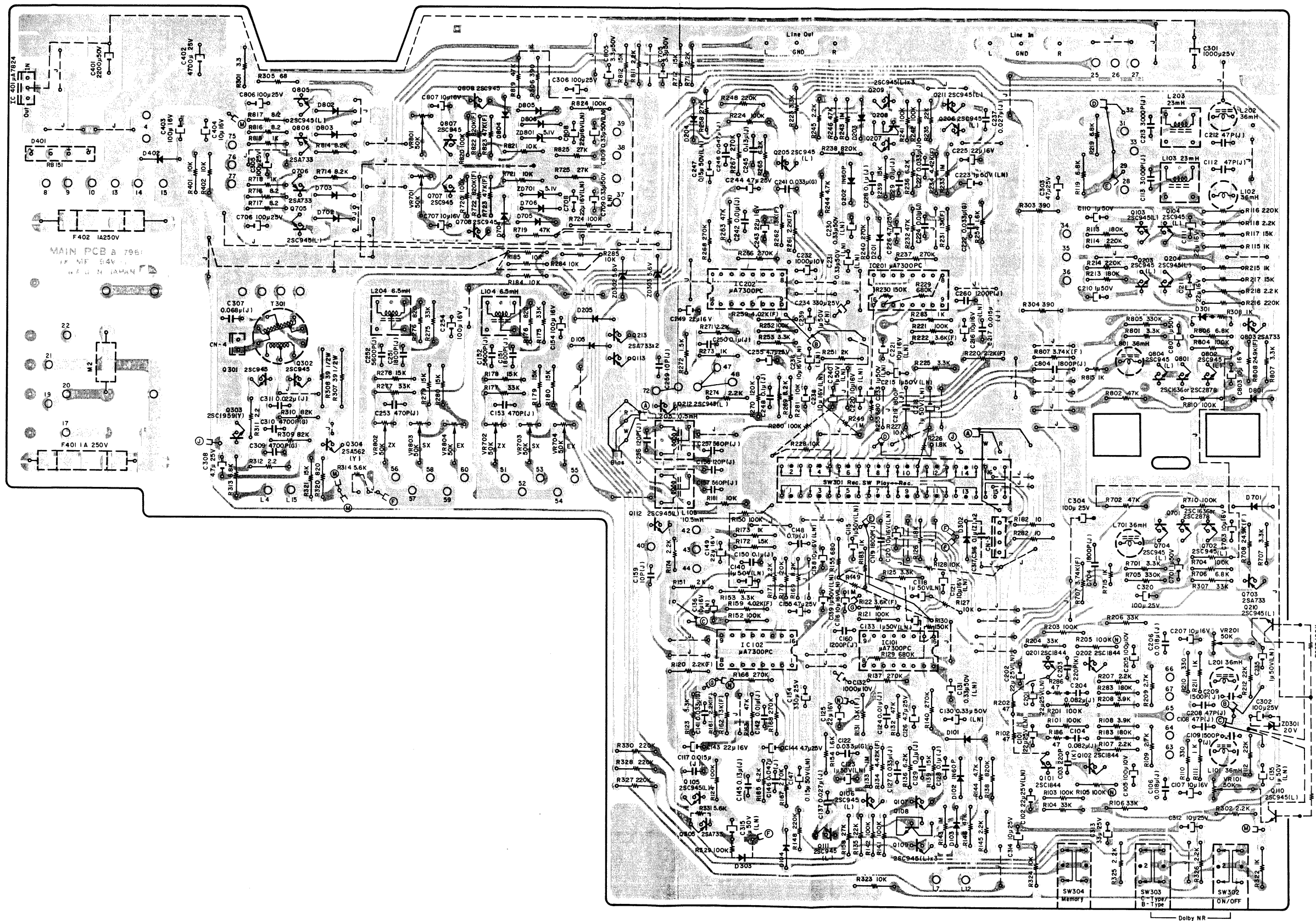

Fig. 7.1.3 Serial Nos.: A30801001 – A30805968
Serial Nos.: A30901001 – A30902973

Note: Diode is 1SS53 unless otherwise specified.

7.2. Volume P.C.B. Ass'y

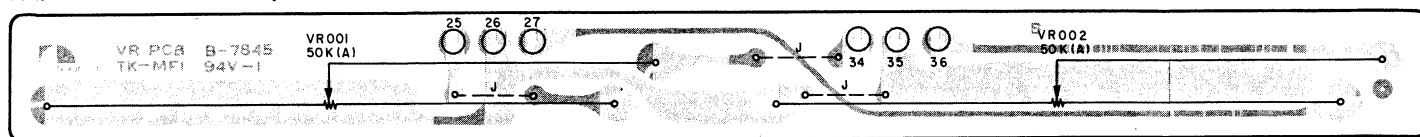

Fig. 7.2

7.3. Lamp P.C.B. Ass'y

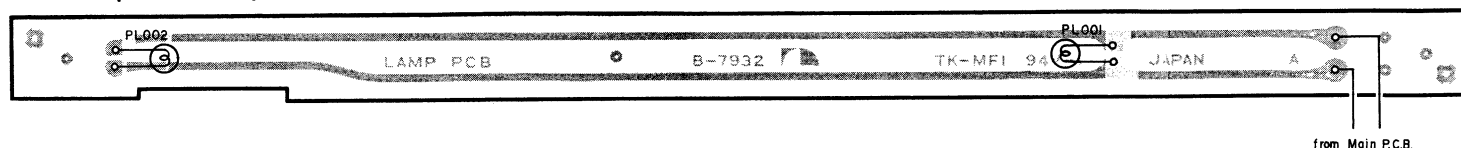

Fig. 7.3

7.4. MPX Filter Switch P.C.B. Ass'y

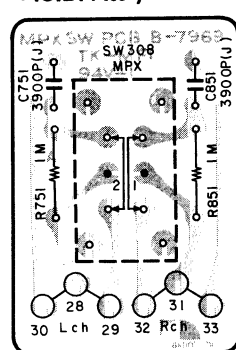

Fig. 7.4

7.5. Headphone Switch P.C.B. Ass'y

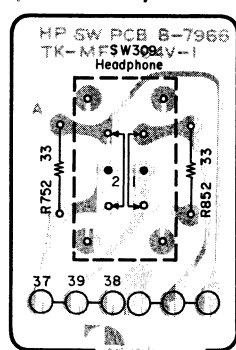

Fig. 7.5

7.6. Bias Tune Volume P.C.B. Ass'y

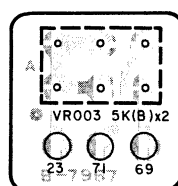

Fig. 7.6

7.7. Indicator P.C.B. Ass'y

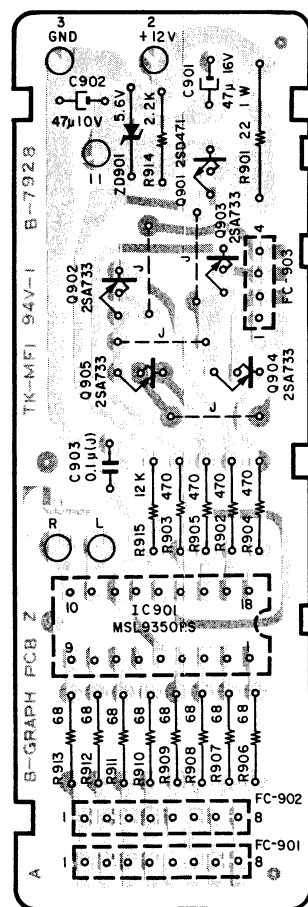

Fig. 7.7

7.8. Switch P.C.B. Ass'y

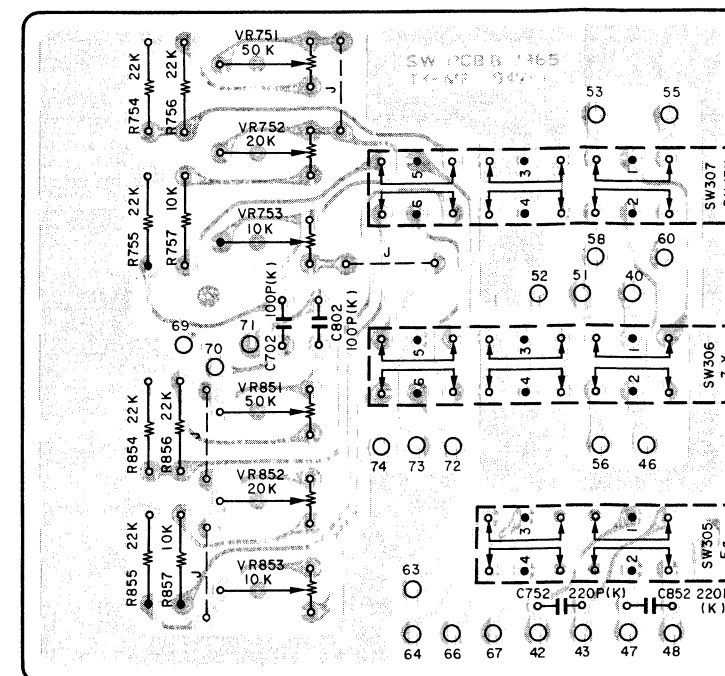

Fig. 7.8.1 Serial No.: A30805969 -
Serial No.: A30902974 -

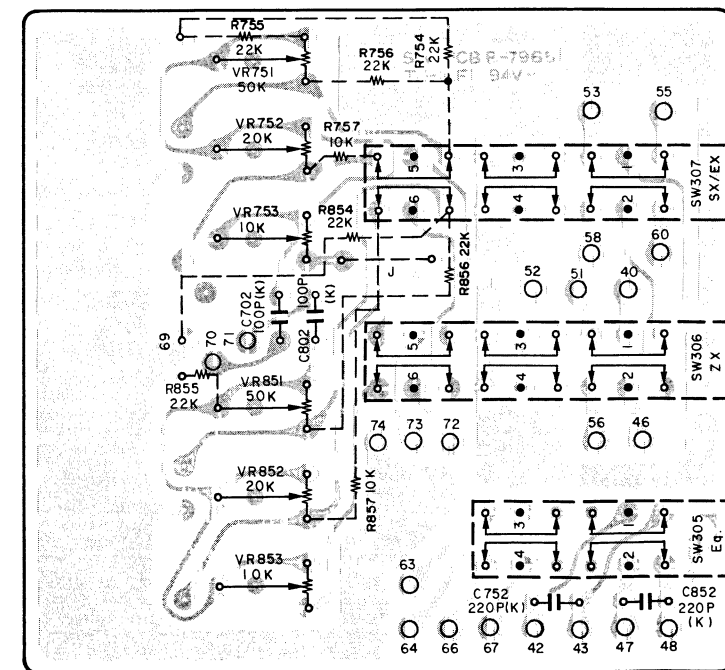
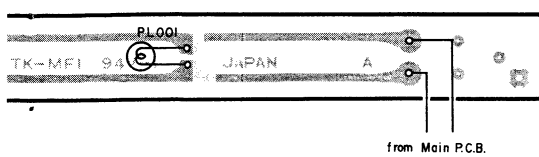
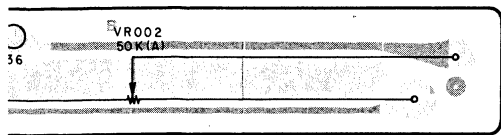

Fig. 7.8.2 Serial Nos.: A30801001 - A30805968
Serial Nos.: A30901001 - A30902973

Schematic Ref. No.	Part No.	
VR001,002	BA04114A	Volume P
	0B07845B 0B07298A	Volume P Slide Vol
PL001,002	BA04416A	Lamp P.C
	0B07932A 0B08674A	Lamp P.C Lamp
R751,851 C751,851 SW308	BA04402A	MPX Filte
	0B07956A 0B05776A 0B01804A 0B07369A	MPX Filte Carbon R Mylar Cap Slide Swit
R752,852 SW309	BA04420A	Headphor
	0B07966A 0B01713A 0B07369A	Headphor Carbon R Slide Swit
VR003	BA04372A	Bias Tune
	0B07967A 0B07355A	Bias Tune Volume
IC901 Q901 Q902,903 904,905 ZD901 R901 R902,903 904,905 R906,907 908,909 910,911 912,913 R914 R915 C901 C902 C903 FC901 FC902 FC903	BA04313A	Indicator
	0B07928A 0B06284A 0B06066A 0B06013A	Indicator IC Transisto Transisto
	0B06268A 0B09378A 0B05576A	Zener Dic Fail Safe Carbon R
	0B01704A	Carbon R
	0B05622A 0B09263A 0B01403A	Carbon R Carbon R Electroly
	0B01836A 0B01780A	Electroly Mylar Cap
	0B05236A 0B05251A 0B05252A 0B06291A	8P Flat C 8P Flat C 4P Flat C Indicator



7.7. Indicator P.C.B. Ass'y

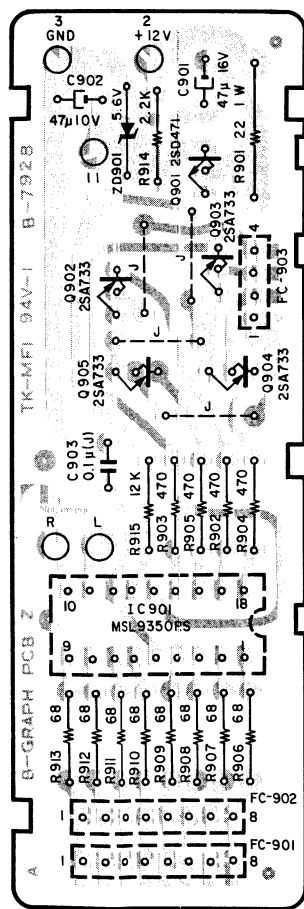

Fig. 7.7

7.8. Switch P.C.B. Ass'y

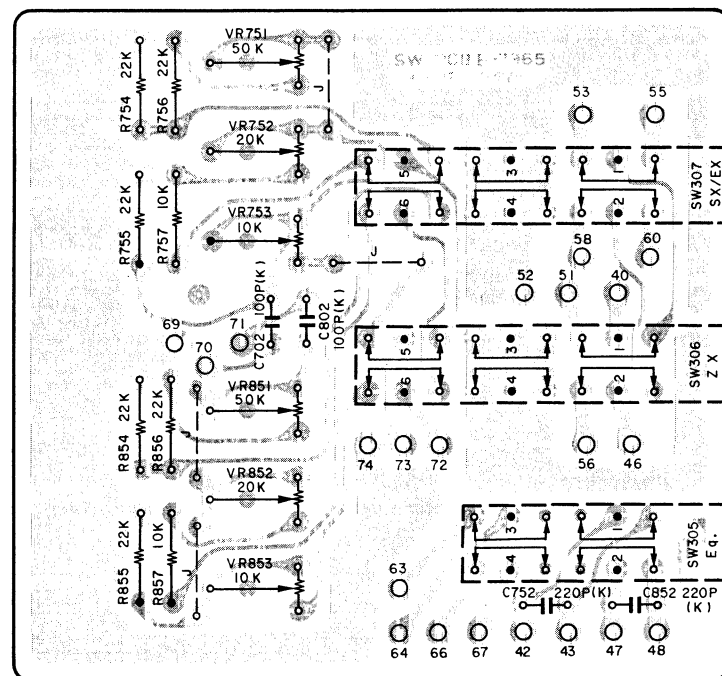

Fig. 7.8.1 Serial No.: A30805969 -
Serial No.: A30902974 -

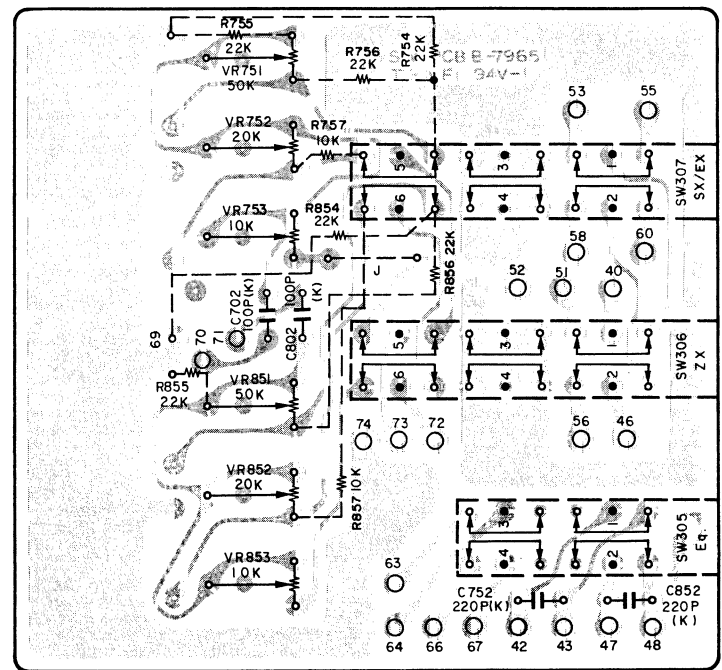

Fig. 7.8.2 Serial Nos.: A30801001 - A30805968
Serial Nos.: A30901001 - A30902973

Schematic Ref. No.	Part No.	Description	Schematic Ref. No.	Part No.	Description
VR001,002	BA04114A	Volume P.C.B. Ass'y	VR751,851 VR752,852 VR753,853	BA04430A	Switch P.C.B. Ass'y
	OB07845B OB07298A	Volume P.C.B. Slide Volume 50K (A)		OB07965A OB07237A OB07261A OB07236A OB05615A	Switch P.C.B. Semi-fixed Volume 50K Semi-fixed Volume 20K Semi-fixed Volume 10K Carbon Resistor 22K ERD-25T J
PL001,002	BA04416A	Lamp P.C.B. Ass'y	R754,755 756,854 855,856 R757,857 C702,802 C752,852	OB01888A OB09282A OB09283A OB07302A	Carbon Resistor 10K ERD-25T J Ceramic Capacitor 100P 50V K Ceramic Capacitor 220P 50V K Push Switch (1 pce.)
	OB07932A OB08674A	Lamp P.C.B. Lamp 5V 200mA			
R751,851 C751,851 SW308	BA04402A	MPX Filter Switch P.C.B. Ass'y	Q449 Q450 D470 R602 R603 R604 R605 C453 PL407	BA04070A	Shut-off P.C.B. Ass'y
	OB07956A OB05776A OB01804A OB07369A	MPX Filter Switch P.C.B. Carbon Resistor 1M ERD-25T J Mylar Capacitor 3900P 50V J Slide Switch 22S			
R752,852 SW309	BA04420A	Headphone Switch P.C.B. Ass'y	OB07839A OB01872A OB06228A OB06181A OB01888A OB05671A OB05615A OB09215A OB01405A OB08552A	BA04126A	Control P.C.B. Ass'y
	OB07966A OB01713A OB07369A	Headphone Switch P.C.B. Carbon Resistor 33 ERD-25T J Slide Switch 22S			
VR003	BA04372A	Bias Tune Volume P.C.B. Ass'y	VR602,603 R606 R607	OB07849B OB09059A OB05698A OB05622A	Control P.C.B. Semi-fixed Volume 5K Carbon Resistor 1.5K ERD-25T J Carbon Resistor 2.2K ERD-25T J
	OB07967A OB07355A	Bias Tune Volume P.C.B. Volume 5K (B) x 2			
IC901 Q901 Q902,903 Q904,905 ZD901 R901 R902,903 R904,905 R906,907 908,909 910,911 912,913 R914 R915 C901 C902 C903 FC901 FC902 FC903	BA04313A	Indicator P.C.B. Ass'y	D601 R608,609 R610,611 612 C605,606 PL601,602 603 OB07297A	BA04424A	Control Switch P.C.B. Ass'y
	OB07928A OB06284A OB06066A OB06013A OB06268A OB09378A OB05576A OB01704A OB05622A OB09263A OB01403A OB01836A OB01780A OB05236A OB05251A OB05252A OB06291A	Indicator P.C.B. IC MSL9350RS Transistor 2SD471 Transistor 2SA733 Zener Diode 5.6V RD5.6EB3 Fail Safe Type Resistor 22 RSF-1B J Carbon Resistor 470 ERD-25T J Carbon Resistor 68 ERD-25T J Carbon Resistor 2.2K ERD-25T J Carbon Resistor 12K ERD-25T J Electrolytic Capacitor 47μ 16V Electrolytic Capacitor 47μ 10V Mylar Capacitor 0.1μ 50V J 8P Flat Cable 8P Flat Cable 80mm 4P Flat Cable 35mm Indicator SEL8806N (1 pce.)			

7.9. Shut-off P.C.B. Ass'y

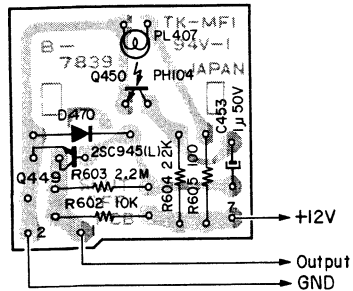

Fig. 7.9

Note: Diode is 1SS53 unless otherwise specified.

7.10. Control P.C.B. Ass'y

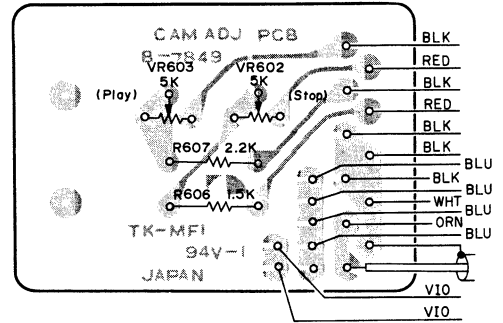

Fig. 7.10

7.11. Control Switch P.C.B. Ass'y

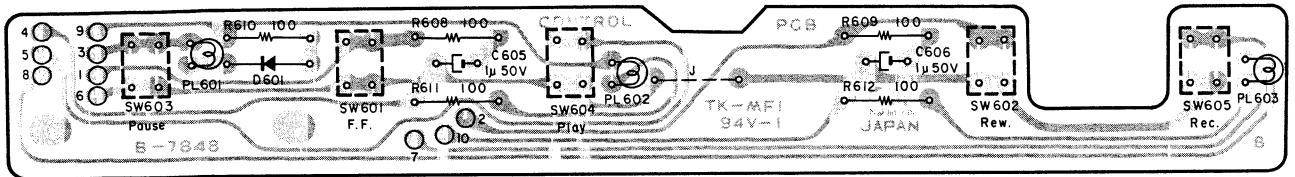

Fig. 7.11

Note: Diode is 1SS53 unless otherwise specified.

7.12. Logic P.C.B. Ass'y

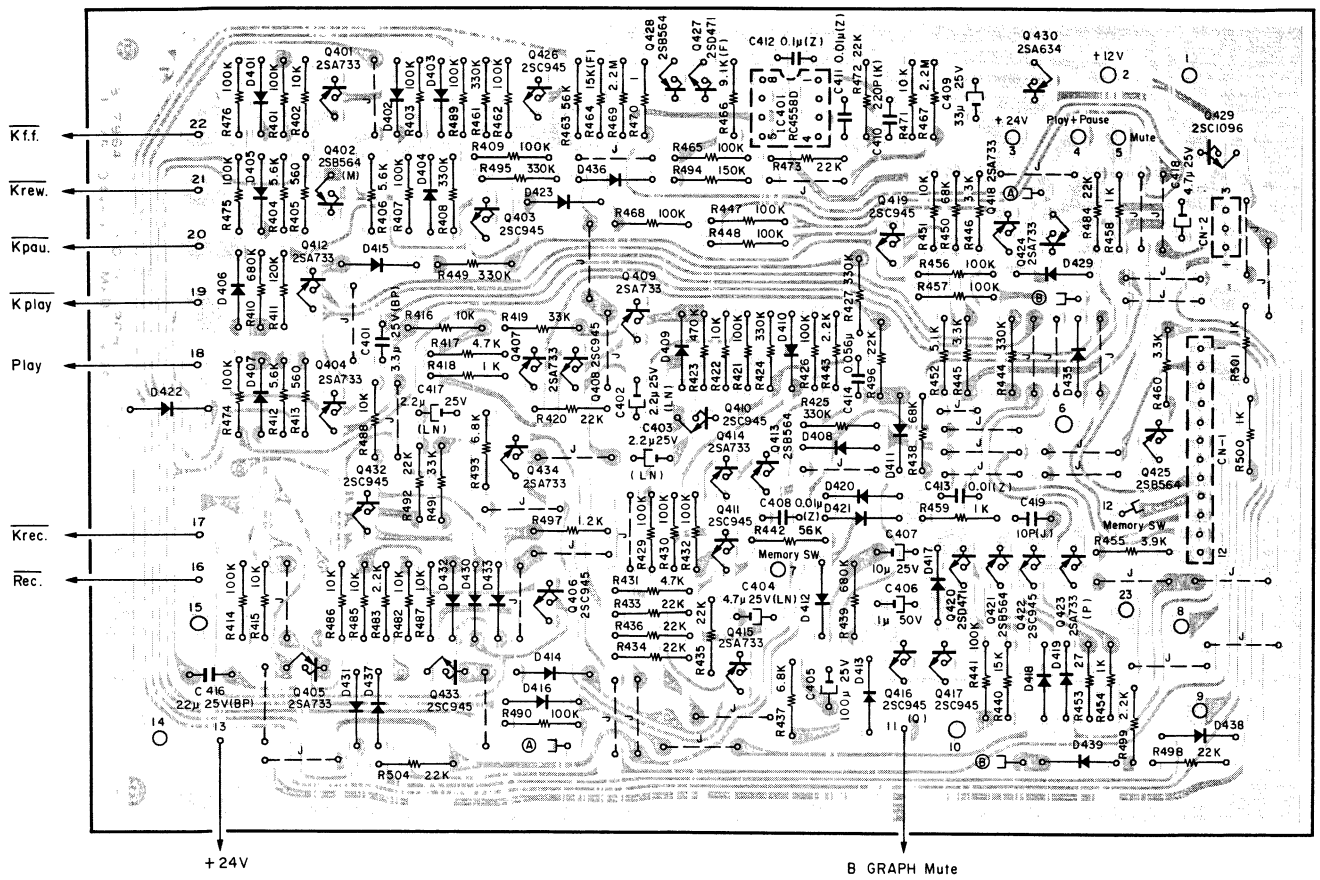

Fig. 7.12.1 Serial No.: A30808688 –
Serial No.: A30908913 –

Schematic Ref. No.	Part No.	Description	Schematic Ref. No.	Part No.	Description
	BA04512A	Logic P.C.B. Ass'y Serial No.: A30808688 – Serial No.: A30908913 –	R420,433 434,435 436,472 473,484 492,496 498,504	OB05615A	Carbon Resistor 22K ERD-25T J
IC401	OB07964C	Logic P.C.B.	R423	OB01684A	Carbon Resistor 470K ERD-25T J
Q401,404 405,407 409,412 414,415 418,424 434	OB06124B OB06013A	IC RC4558D Transistor 2SA733	R437,493 R438,450 R440 R442,463 R443,483 499	OB01682A OB05692A OB01683A OB05508A OB05622A	Carbon Resistor 6.8K ERD-25T J Carbon Resistor 68K ERD-25T J Carbon Resistor 15K ERD-25T J Carbon Resistor 56K ERD-25T J Carbon Resistor 2.2K ERD-25T J
Q402	OB06332A	Transistor 2SB564 (M)	R445,446 460	OB01681A	Carbon Resistor 3.3K ERD-25T J
Q403,406 408,410 411,417 419,422 426,432 433	OB06100A	Transistor 2SC945 (A)	R452 R453 R455 R464 R466 R467,469	OB09314A OB09384A OB05675A OB09340A OB09328A OB05671A	Carbon Resistor 5.1K ERD-25T J Fail Safe Type Resistor 27 RDF-25S J Carbon Resistor 3.9K ERD-25T J Metal Film Resistor 15K SN14K2E F Metal Film Resistor 9.1K SN14K2E F Carbon Resistor 2.2M ERD-25T J
Q413,425 428	OB06069A	Transistor 2SB564	R470 R494 R497	OB09214A OB05626A OB05623A	Fail Safe Type Resistor 1 RDF-25S J Carbon Resistor 150K ERD-25T J Carbon Resistor 1.2K ERD-25T J
Q416 Q420,427 Q421 Q423 Q429 Q430	OB06251A OB06066A OB06252A OB06155A OB06020A OB06012A	Transistor 2SC945 (Q) Transistor 2SD471 Transistor 2SB564 (K) Transistor 2SA733 (P) Transistor 2SC1096 Transistor 2SA634	C401 C402,403 417	OB09345A OB09332A	Electrolytic Capacitor 3.3μ 25V (BP) Electrolytic Capacitor 2.2μ 25V (LN)
D401-423 429-433 435-439	OB06181A	Silicon Diode 1SS53 (33 pcs.)	C404 C405 C406 C407 C408,411 413 C409 C410 C412 C414 C416 C418 C419	OB09333A OB01272A OB01405A OB01674A OB09290A	Electrolytic Capacitor 4.7μ 25V (LN) Electrolytic Capacitor 100μ 25V Electrolytic Capacitor 1μ 50V Electrolytic Capacitor 10μ 25V Ceramic Capacitor 0.01μ 50V Z
R401,403 407,409 414,421 426,429 430,432 441,447 448,456 457,462 465,468 474,475 476,489 490	OB01889A	Carbon Resistor 100K ERD-25T J	CN1 CN2	OB09251A OB09283A OB09292A OB01676A OB09368A OB01402A OB09277A OB08681A OB08653A	Electrolytic Capacitor 33μ 25V Ceramic Capacitor 220P 50V K Ceramic Capacitor 0.1μ 50V Z Mylar Capacitor 0.056μ 50V Electrolytic Capacitor 22μ 25V (BP) Electrolytic Capacitor 4.7μ 25V Ceramic Capacitor 10P 50V J 12P-T Post 3P-T Post
R402,415 416,422 451,471 482,485 486,487 488	OB01888A	Carbon Resistor 10K ERD-25T J	OB08606A OB08607A OE00507A OE00607A	OB08606A OB08607A OE00507A OE00607A	Transistor Mica TO-202 (1 pce.) Transistor Bushing TO-202 (1 pce.) Nut Hex. M3 (1 pce.) Screw M3x8 Philips Pan Head (3A) (1 pce.)
R404,406 412	OB01887A	Carbon Resistor 5.6K ERD-25T J	OE00857A	OE00857A	BT Screw M3x6 Philips Binding Head (4 pcs.)
R405,413 R408,424 425,427 444,449 461,495	OB05575A OB05627A	Carbon Resistor 560 ERD-25T J Carbon Resistor 330K ERD-25T J	OJ04349A OJ04350A	OJ04349A OJ04350A	P.C.B. Holder L (1 pce.) P.C.B. Holder R (1 pce.)
R410,439 R411 R417,431 R418,454 458,459 500,501 R419,491	OB09335A OB05621A OB01846A OB01857A OB05509A	Carbon Resistor 680K ERD-25T J Carbon Resistor 120K ERD-25T J Carbon Resistor 4.7K ERD-25T J Carbon Resistor 1K ERD-25T J Carbon Resistor 33K ERD-25T J			

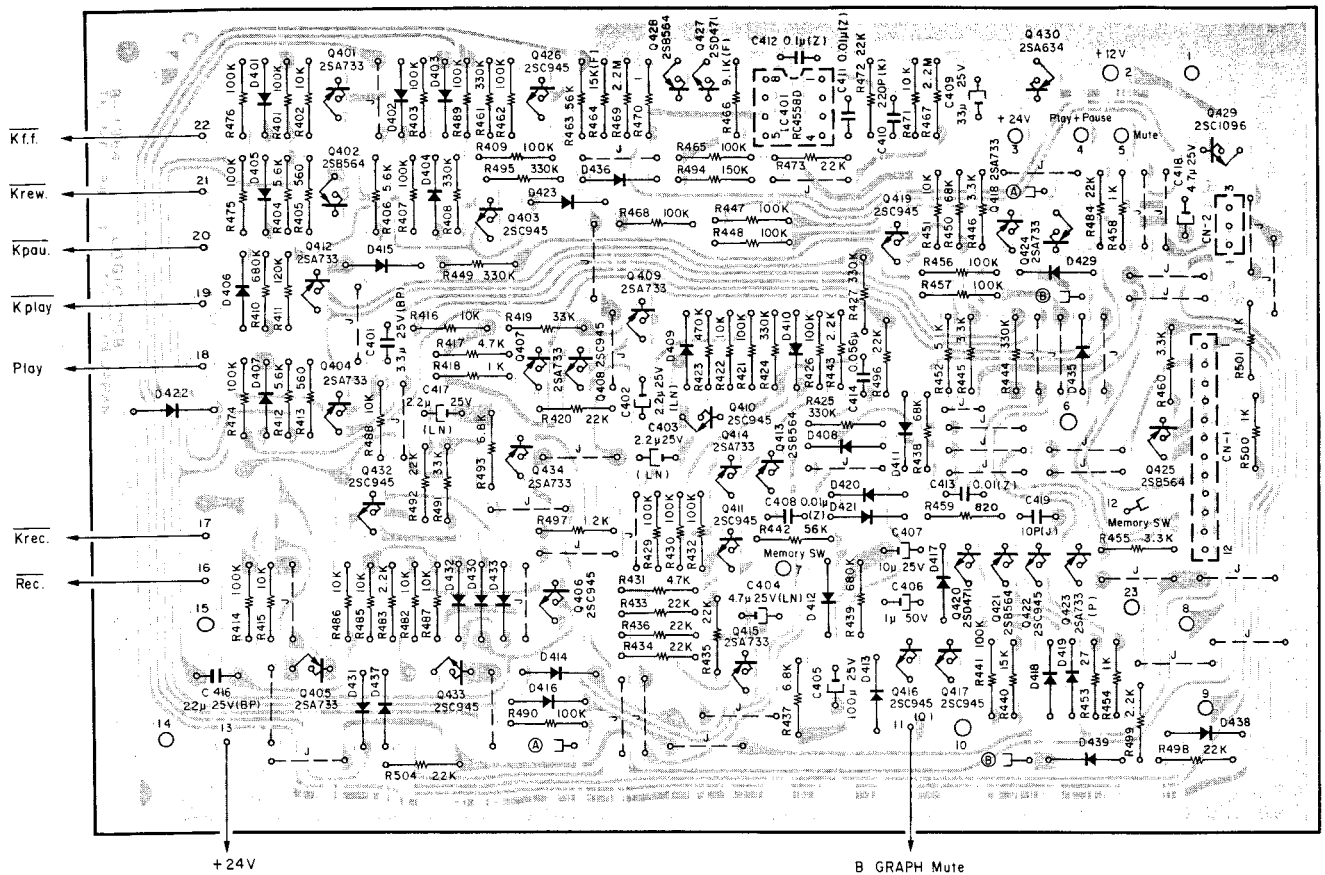

Fig. 7.12.2 Serial Nos.: A30801001 – A30808687
Serial Nos.: A30901001 – A30908912

Schematic Ref. No.	Part No.	Description	Schematic Ref. No.	Part No.	Description
	BA04512A	Logic P.C.B. Ass'y Serial Nos.: A30801001 – A30808687 Serial Nos.: A30901001 – A30908912	R420,433 434,435 436,472 473,484 492,496 498,504	0B05615A	Carbon Resistor 22K ERD-25T J
IC401	0B07964C	Logic P.C.B.	R423	0B01684A	Carbon Resistor 470K ERD-25T J
Q401,404	0B06124B	IC RC4558D	R437,493	0B01682A	Carbon Resistor 6.8K ERD-25T J
405,407	0B06013A	Transistor 2SA733	R438,450	0B05692A	Carbon Resistor 68K ERD-25T J
409,412			R440	0B01683A	Carbon Resistor 15K ERD-25T J
414,415			R442,463	0B05508A	Carbon Resistor 56K ERD-25T J
418,424			R443,483	0B05622A	Carbon Resistor 2.2K ERD-25T J
434			499		
Q402,413	0B06069A	Transistor 2SB564	R445,446	0B01681A	Carbon Resistor 3.3K ERD-25T J
425,428			455,460		
Q403,406	0B06100A	Transistor 2SC945 (A)	R452	0B09314A	Carbon Resistor 5.1K ERD-25T J
408,410			R453	0B09384A	Fail Safe Type Resistor 27 RDF-25S J
411,417			R459	0B01680A	Carbon Resistor 820 ERD-25T J
419,422			R464	0B09340A	Metal Film Resistor 15K SN14K2E F
426,432			R466	0B09328A	Metal Film Resistor 9.1K SN14K2E F
433			R467,469	0B05671A	Carbon Resistor 2.2M ERD-25T J
Q416	0B06251A	Transistor 2SC945 (Q)	R470	0B09214A	Fail Safe Type Resistor 1 RDF-25S J
Q420,427	0B06066A	Transistor 2SD471	R494	0B05626A	Carbon Resistor 150K ERD-25T J
Q421	0B06252A	Transistor 2SB564 (K)	R497	0B05623A	Carbon Resistor 1.2K ERD-25T J
Q423	0B06155A	Transistor 2SA733 (P)	C401	0B09345A	Electrolytic Capacitor 3.3μ 25V (BP)
Q429	0B06020A	Transistor 2SC1096	C402,403	0B09332A	Electrolytic Capacitor 2.2μ 25V (LN)
Q430	0B06012A	Transistor 2SA634	417		
D401-423	0B06181A	Silicon Diode 1SS53 (33 pcs.)	C404	0B09333A	Electrolytic Capacitor 4.7μ 25V (LN)
429-433			C405	0B01272A	Electrolytic Capacitor 100μ 25V
435-439			C406	0B01405A	Electrolytic Capacitor 1μ 50V
R401,403	0B01889A	Carbon Resistor 100K ERD-25T J	C407	0B01674A	Electrolytic Capacitor 10μ 25V
407,409			C408,411	0B09290A	Ceramic Capacitor 0.01μ 50V Z
414,421			413		
426,429			C409	0B09251A	Electrolytic Capacitor 33μ 25V
430,432			C410	0B09283A	Ceramic Capacitor 220P 50V K
441,447			C412	0B09292A	Ceramic Capacitor 0.1μ 50V Z
448,456			C414	0B01676A	Mylar Capacitor 0.056μ 50V
457,462			C416	0B09368A	Electrolytic Capacitor 22μ 25V (BP)
465,468			C418	0B01402A	Electrolytic Capacitor 4.7μ 25V
474,475			C419	0B09277A	Ceramic Capacitor 10P 50V J
476,489			CN1	0B08681A	12P-T Post
490			CN2	0B08653A	3P-T Post
R402,415	0B01888A	Carbon Resistor 10K ERD-25T J		0B08606A	Transistor Mica TO-202 (1 pce.)
416,422				0B08607A	Transistor Bushing TO-202 (1 pce.)
451,471				0E00507A	Nut Hex. M3 (1 pce.)
482,485				0E00510A	Screw M3x8 Philips Pan Head (2A) (1 pce.)
486,487					
488				0E00857A	BT Screw M3x6 Philips Binding Head (4 pcs.)
R404,406	0B01887A	Carbon Resistor 5.6K ERD-25T J		0J04349A	P.C.B. Holder L (1 pce.)
412				0J04350A	P.C.B. Holder R (1 pce.)
R405,413	0B05575A	Carbon Resistor 560 ERD-25T J			
R408,424	0B05627A	Carbon Resistor 330K ERD-25T J			
425,427					
444,449					
461,495					
R410,439	0B09335A	Carbon Resistor 680K ERD-25T J			
R411	0B05621A	Carbon Resistor 120K ERD-25T J			
R417,431	0B01846A	Carbon Resistor 4.7K ERD-25T J			
R418,454	0B01857A	Carbon Resistor 1K ERD-25T J			
458,500					
501					
R419,491	0B05509A	Carbon Resistor 33K ERD-25T J			

8. MECHANISM ASS'Y AND PARTS LIST

8.1. Synthesis

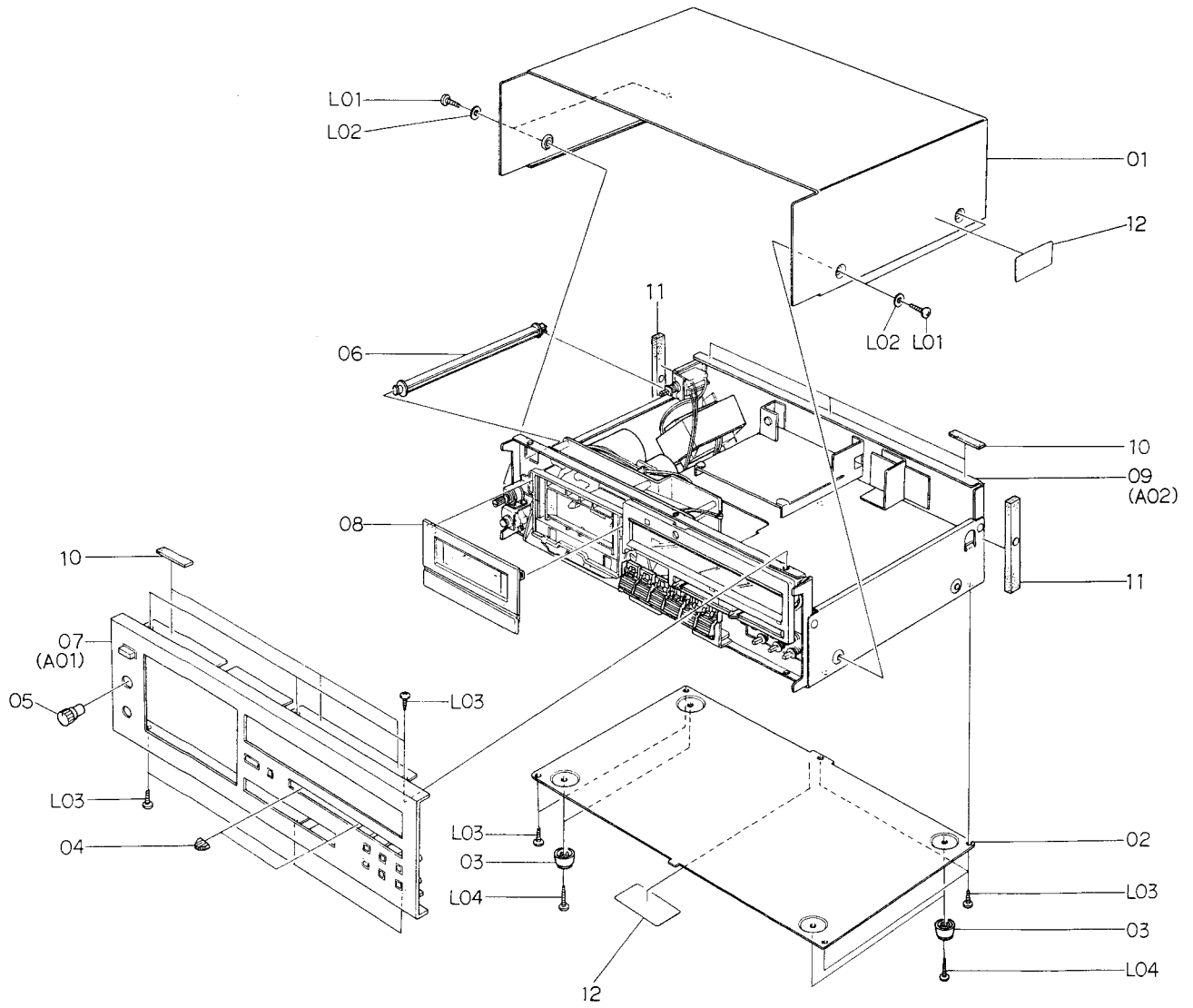

Fig. 8.1

Schematic Ref. No.	Part No.	Description	Q'ty	Schematic Ref. No.	Part No.	Description	Q'ty
	HA04095A	Synthesis (U.S.A. & Canada) (Silver)	1		HA04095A	Synthesis (U.S.A. & Canada) (Silver)	1
	HA04 101A	Synthesis (U.S.A. & Canada) (Black)	1		HA04101A	Synthesis (U.S.A. & Canada) (Black)	1
	HA04096A	Synthesis (Japan) (Silver)	1		HA04096A	Synthesis (Japan) (Silver)	1
	HA04 102A	Synthesis (Japan) (Black)	1		HA04102A	Synthesis (Japan) (Black)	1
	HA04099A	Synthesis (220V Class 2) (Silver)	1		HA04099A	Synthesis (220V Class 2) (Silver)	1
	HA04 105A	Synthesis (220V Class 2) (Black)	1		HA04105A	Synthesis (220V Class 2) (Black)	1
	HA04094A	Synthesis (UK) (Silver)	1		HA04094A	Synthesis (UK) (Silver)	1
	HA04 100A	Synthesis (UK) (Black)	1		HA04100A	Synthesis (UK) (Black)	1
	HA04998A	Synthesis (Australia) (Silver)	1		HA04998A	Synthesis (Australia) (Silver)	1
	HA04 104A	Synthesis (Australia) (Black)	1		HA04104A	Synthesis (Australia) (Black)	1
	HA04097A	Synthesis (Others) (Silver)	1		HA04097A	Synthesis (Others) (Silver)	1
	HA04 103A	Synthesis (Others) (Black)	1		HA04103A	Synthesis (Others) (Black)	1
		Serial No.:				Serial Nos.:	
		A30808688 –				A30801001 – A30808687	
		A30908913 –				A30901001 – A30908912	
01	0H03768A	Top Cover	1	01	0H03768A	Top Cover	1
02	0H03769B	Bottom Cover	1	02	0H03769B	Bottom Cover	1
03	0J03564A	Leg T-H	4	03	0J03564A	Leg T-H	4
04	0H03780A	Volume Knob (Silver)	2	04	0H03780A	Volume Knob (Silver)	2
	0H03794B	Volume Knob (Black)	2		0H03794B	Volume Knob (Black)	2
05	0H03923A	Bias Adjustment Knob (Silver)	1	05	0H03923A	Bias Adjustment Knob (Silver)	1
	0H03924A	Bias Adjustment Knob (Black)	1		0H03924A	Bias Adjustment Knob (Black)	1
06	0J04066C	Power Switch Joint Bar	1	06	0J04066C	Power Switch Joint Bar	1
07	HA04090A	Front Panel Ass'y (Silver)	1	07	HA04090A	Front Panel Ass'y (Silver)	1
	HA04091A	Front Panel Ass'y (Black)	1		HA04091A	Front Panel Ass'y (Black)	1
08	HA03848A	Cassette Case Cover Ass'y (Silver)	1	08	HA03848A	Cassette Case Cover Ass'y (Silver)	1
	HA03872A	Cassette Case Cover Ass'y (Black)	1		HA03872A	Cassette Case Cover Ass'y (Black)	1
09	JA03802B	Synthesis Mechanism Ass'y (U.S.A. & Canada) (Silver)	1	09	JA03802A	Synthesis Mechanism Ass'y (U.S.A. & Canada) (Silver)	1
	JA03834B	Synthesis Mechanism Ass'y (U.S.A. & Canada) (Black)	1		JA03834A	Synthesis Mechanism Ass'y (U.S.A. & Canada) (Black)	1
	JA03803B	Synthesis Mechanism Ass'y (Japan) (Silver)	1		JA03803A	Synthesis Mechanism Ass'y (Japan) (Silver)	1
	JA03835B	Synthesis Mechanism Ass'y (Japan) (Black)	1		JA03835A	Synthesis Mechanism Ass'y (Japan) (Black)	1
	JA03806B	Synthesis Mechanism Ass'y (220V Class 2) (Silver)	1		JA03806A	Synthesis Mechanism Ass'y (220V Class 2) (Silver)	1
	JA03838B	Synthesis Mechanism Ass'y (220V Class 2) (Black)	1		JA03838A	Synthesis Mechanism Ass'y (220V Class 2) (Black)	1
	JA03801B	Synthesis Mechanism Ass'y (UK) (Silver)	1		JA03801A	Synthesis Mechanism Ass'y (UK) (Silver)	1
	JA03833B	Synthesis Mechanism Ass'y (UK) (Black)	1		JA03833A	Synthesis Mechanism Ass'y (UK) (Black)	1
	JA03805B	Synthesis Mechanism Ass'y (Australia) (Silver)	1		JA03805A	Synthesis Mechanism Ass'y (Australia) (Silver)	1
	JA03837B	Synthesis Mechanism Ass'y (Australia) (Black)	1		JA03837A	Synthesis Mechanism Ass'y (Australia) (Black)	1
	JA03804B	Synthesis Mechanism Ass'y (Others) (Silver)	1		JA03804A	Synthesis Mechanism Ass'y (Others) (Silver)	1
	JA03936B	Synthesis Mechanism Ass'y (Others) (Black)	1		JA03936A	Synthesis Mechanism Ass'y (Others) (Black)	1
10	0H03781A	Cushion A	6	10	0H03781A	Cushion A	6
11	0H03995A	Cushion B	2	11	0H03995A	Cushion B	2
12	0M04101B	Caution Label	2	12	0M04101B	Caution Label	2
L01	0E00858A	BT Screw M4x6 Philips Binding Head (Black Chromate)	4	L01	0E00858A	BT Screw M4x6 Philips Binding Head (Black Chromate)	4
L02	0E00736A	Washer 4mm (Black Chromate)	4	L02	0E00736A	Washer 4mm (Black Chromate)	4
L03	0E00857A	BT Screw M3x6 Philips Binding Head	11	L03	0E00857A	BT Screw M3x6 Philips Binding Head	11
L04	0E00865A	BT Screw M3x10 Philips Binding Head	4	L04	0E00865A	BT Screw M3x10 Philips Binding Head	4

8.2. Front Panel Ass'y (A01)

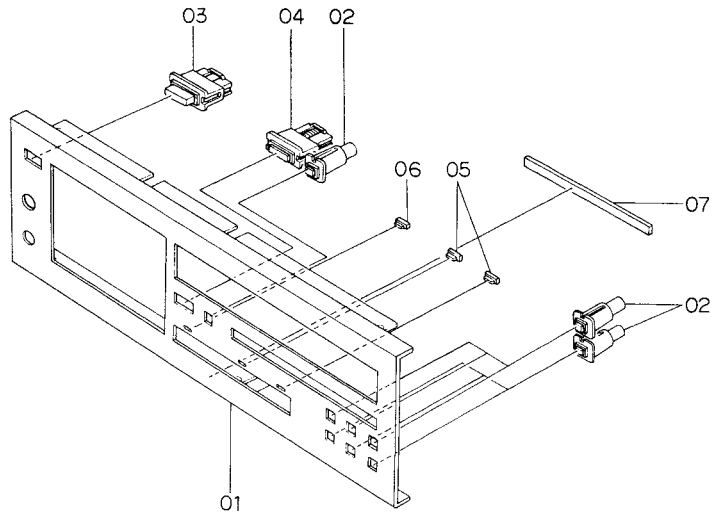

Fig. 8.2

8.3. Synthesis Mechanism Ass'y (A02)

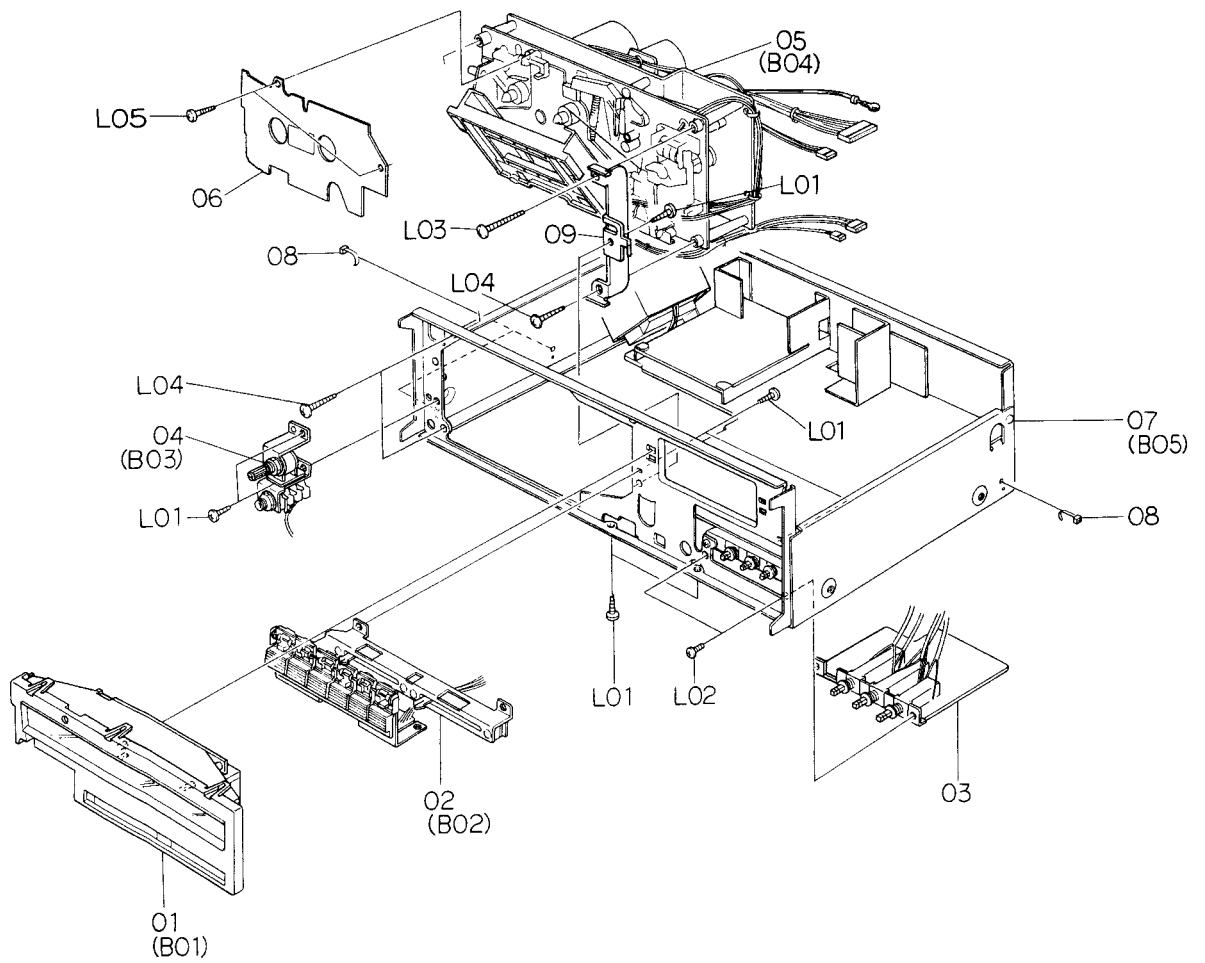

Fig. 8.3

Schematic Ref. No.	Part No.	Description	Q'ty	Schematic Ref. No.	Part No.	Description	Q'ty	
A01	HA04090A	Front Panel Ass'y (Silver)	1	09	0J04130B	Mechanism Bracket	1	
	HA04091A	Front Panel Ass'y (Black) Serial No.: A308.901001 -	1	L01	0E00857A	BT Screw M3x6 Philips Binding Head	7	
	01	0H03932A	Front Panel (Silver)	1	L02	0E00502A	Screw M3x5 Philips Pan Head	2
		0H03933A	Front Panel (Black)	1	L03	0E00924A	BT Screw M4x16 Philips Binding Head (Chromate)	1
	02	HA03852A	Push Button Ass'y C (Silver)	1	L04	0E00944A	BT Screw M4x15 Philips Binding Head (Black Chromate)	3
		HA03873A	Push Button Ass'y C (Black)	1	L05	0E00832A	BT Screw M3x14 Philips Pan Head	2
	03	HA03853A	Push Button Ass'y D (Silver)	1	A02	JA03802A	Synthesis Mechanism Ass'y (U.S.A. & Canada) (Silver)	1
		HA03874A	Push Button Ass'y D (Black)	1		JA03834A	Synthesis Mechanism Ass'y (U.S.A. & Canada) (Black)	1
	04	HA03854A	Eject Button Ass'y (Silver)	1		JA03803A	Synthesis Mechanism Ass'y (Japan) (Silver)	1
		HA03875A	Eject Button Ass'y (Black)	1		JA03835A	Synthesis Mechanism Ass'y (Japan) (Black)	1
	05	0H03744B	Green Lens	2		JA03806A	Synthesis Mechanism Ass'y (220V Class 2) (Silver)	1
	06	0H03745B	Orange Lens	1		JA03838A	Synthesis Mechanism Ass'y (220V Class 2) (Black)	1
	07	0J04094A	Control Button Pad	1		JA03801A	Synthesis Mechanism Ass'y (UK) (Silver)	1
	-	0J04081A	Adhesive Tape 55x6	5		JA03833A	Synthesis Mechanism Ass'y (UK) (Black)	1
	-	0J04082A	Adhesive Tape 30x6	2		JA03805A	Synthesis Mechanism Ass'y (Australia) (Silver)	1
	A02	JA03802B	Synthesis Mechanism Ass'y (U.S.A. & Canada) (Silver)	1		JA03837A	Synthesis Mechanism Ass'y (Australia) (Black)	1
		JA03834B	Synthesis Mechanism Ass'y (U.S.A. & Canada) (Black)	1		JA03804A	Synthesis Mechanism Ass'y (Others) (Silver)	1
JA03803B		Synthesis Mechanism Ass'y (Japan) (Silver)	1	JA03836A		Synthesis Mechanism Ass'y (Others) (Black)	1	
JA03835B		Synthesis Mechanism Ass'y (Japan) (Black)	1	Serial Nos.:				
JA03806B		Synthesis Mechanism Ass'y (220V Class 2) (Silver)	1	A30801001 - A30808687				
JA03838B		Synthesis Mechanism Ass'y (220V Class 2) (Black)	1	A30901001 - A30908912				
JA03801B		Synthesis Mechanism Ass'y (UK) (Silver)	1	01		HA04089A	Meter Escutcheon Ass'y	1
JA03833B		Synthesis Mechanism Ass'y (UK) (Black)	1	02		JA03849A	Control Switch Holder Ass'y (Silver)	1
JA03805B		Synthesis Mechanism Ass'y (Australia) (Silver)	1		JA03850A	Control Switch Holder Ass'y (Black)	1	
JA03837B		Synthesis Mechanism Ass'y (Australia) (Black)	1	03	BA04430A	Switch P.C.B. Ass'y	1	
JA03804B		Synthesis Mechanism Ass'y (Others) (Silver)	1	04	JA03782A	Headphone Jack Ass'y	1	
JA03836B		Synthesis Mechanism Ass'y (Others) (Black)	1	05	CA08266A	Mechanism Ass'y 480Z	1	
		Serial No.:		06	CA08276A	Cover Plate Ass'y	1	
		A30808688 -		07	JA03784A	Chassis Ass'y (U.S.A. & Canada)	1	
		A30908913 -			JA03785A	Chassis Ass'y (Japan)	1	
01		HA04089A	Meter Escutcheon Ass'y	1	JA03788A	Chassis Ass'y (220V Class 2)	1	
02		JA03849A	Control Switch Holder Ass'y (Silver)	1	JA03783A	Chassis Ass'y (UK)	1	
	JA03850A	Control Switch Holder Ass'y (Black)	1	JA03787A	Chassis Ass'y (Australia)	1		
03	BA04430A	Switch P.C.B. Ass'y	1	JA03786A	Chassis Ass'y (Others)	1		
04	JA03782A	Headphone Jack Ass'y	1	08	0B08515A	Insu-Lock	18	
05	CA08312A	Mechanism Ass'y 480Z	1	09	0J04130B	Mechanism Bracket	1	
06	CA08276A	Cover Plate Ass'y	1	L01	0E00857A	BT Screw M3x6 Philips Binding Head	7	
07	JA03784B	Chassis Ass'y (U.S.A. & Canada)	1	L02	0E00502A	Screw M3x5 Philips Pan Head	2	
	JA03785B	Chassis Ass'y (Japan)	1	L03	0E00924A	BT Screw M4x16 Philips Binding Head (Chromate)	1	
	JA03788B	Chassis Ass'y (220V Class 2)	1	L04	0E00867A	BT Screw M4x15 Philips Binding Head	3	
	JA03783B	Chassis Ass'y (UK)	1	L05	0E00832A	BT Screw M3x14 Philips Pan Head	2	
	JA03787B	Chassis Ass'y (Australia)	1					
	JA03786B	Chassis Ass'y (Others)	1					
08	0B08515A	Insu-Lock	18					

8.4. Meter Escutcheon Ass'y (B01)

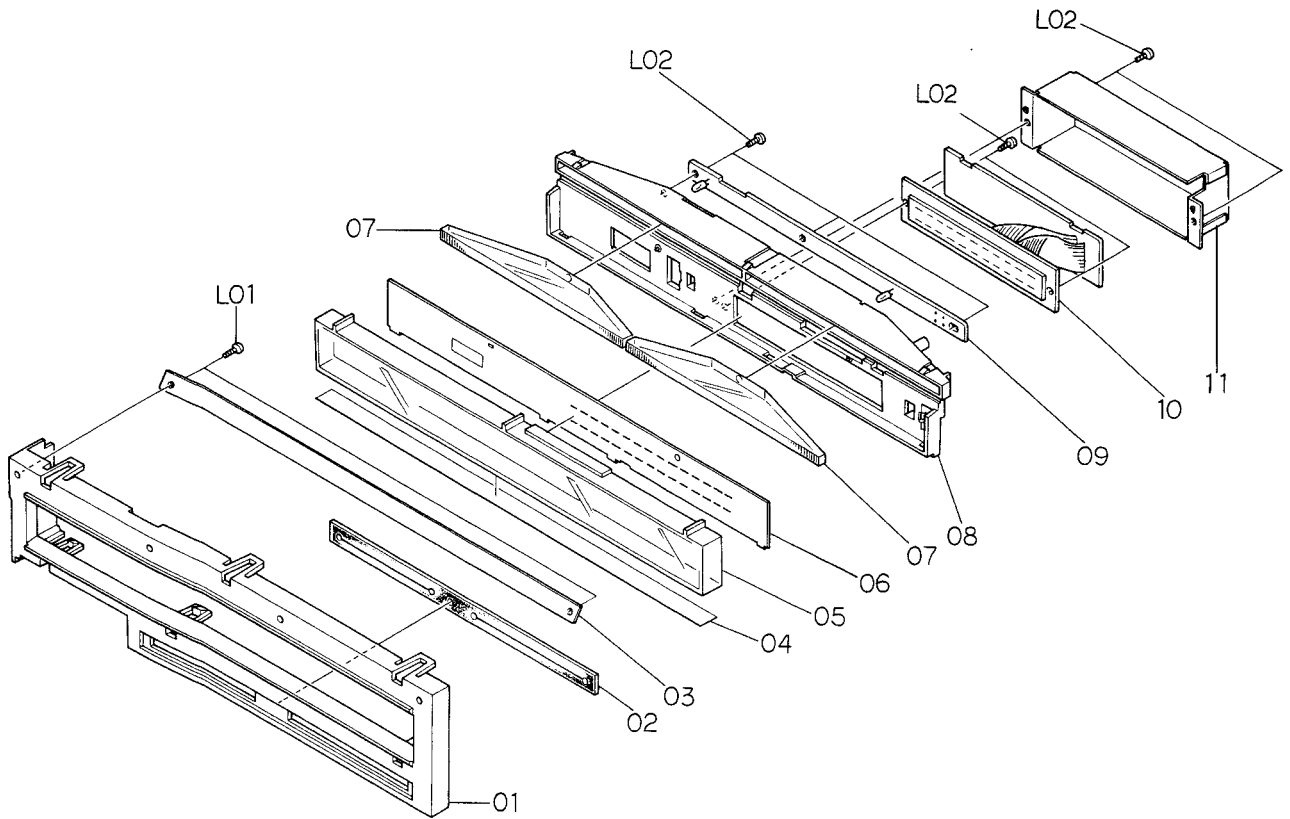

Fig. 8.4

8.5. Control Switch Holder Ass'y (B02)

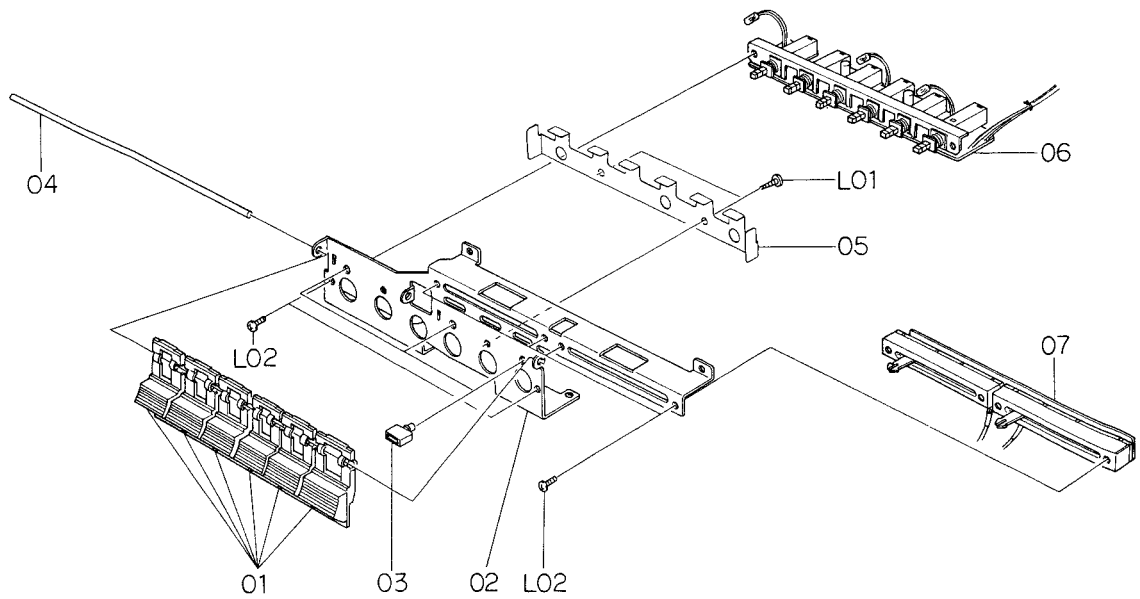

Fig. 8.5

8.6. Headphone Jack Ass'y (B03)

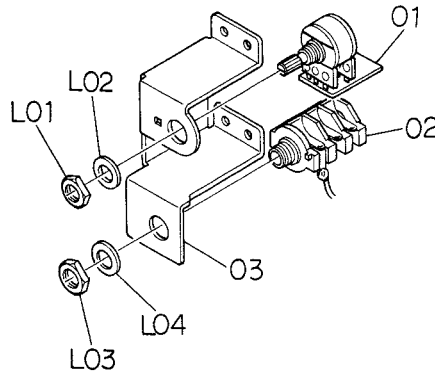

Fig. 8.6

Schematic Ref. No.	Part No.	Description	Q'ty	Schematic Ref. No.	Part No.	Description	Q'ty
B01	HA04089A	Meter Escutcheon Ass'y Serial No.: A308.901001 -	1	B03	JA03782A	Headphone Jack Ass'y Serial No.: A308.901001 -	1
01	0H03931A	Meter Escutcheon	1	01	BA04372A	Bias Tune Volume P.C.B. Ass'y	1
02	0H03786B	Volume Cover	1	02	0B08511A	Headphone Jack	1
03	0H03926A	Mirror	1	03	0J04299A	Headphone Jack Holder	1
04	0H03928A	Light Intercepting Seal	1	L01	-	Bias Tune Volume Nut	(1)
05	0H03929A	Meter Cover	1	L02	-	Bias Tune Volume Washer	(1)
06	0H03927B	Meter Scale	1	L03	-	Headphone Jack Nut	(1)
07	0H03925A	Lamp House	2	L04	-	Headphone Jack Washer	(1)
08	0H03930B	Meter Base	1				
09	BA04416A	Lamp P.C.B. Ass'y	1				
10	BA04313A	Indicator P.C.B. Ass'y	1				
11	0J04298A	Shield Case	1				
L01	0E00855A	BT Screw M2x6 Philips Binding Head	2				
L02	0E00841A	BT Screw M2x4 Philips Pan Head	7				
B02	JA03849A	Control Switch Holder Ass'y (Silver)	1				
	JA03850A	Control Switch Holder Ass'y (Black)	1				
		Serial No.: A308.901001 -					
01	0H03772C	Control Button (Silver)	6				
	0H03793A	Control Button (Black)	6				
02	0J04355A	Control Switch Holder	1				
03	0J04356A	Lamp Cover	3				
04	0J04073A	Control Button Shaft	1				
05	0J04357A	Control Button Spring	1				
06	BA04424A	Control Switch P.C.B. Ass'y	1				
07	BA04114A	Volume P.C.B. Ass'y	1				
L01	0E00857A	BT Screw M3x6 Philips Binding Head	2				
L02	0E00502A	Screw M3x5 Philips Pan Head	6				
L03	0E00117A	Washer 2mm	2				

8.7. Mechanism Ass'y 480Z (B04)

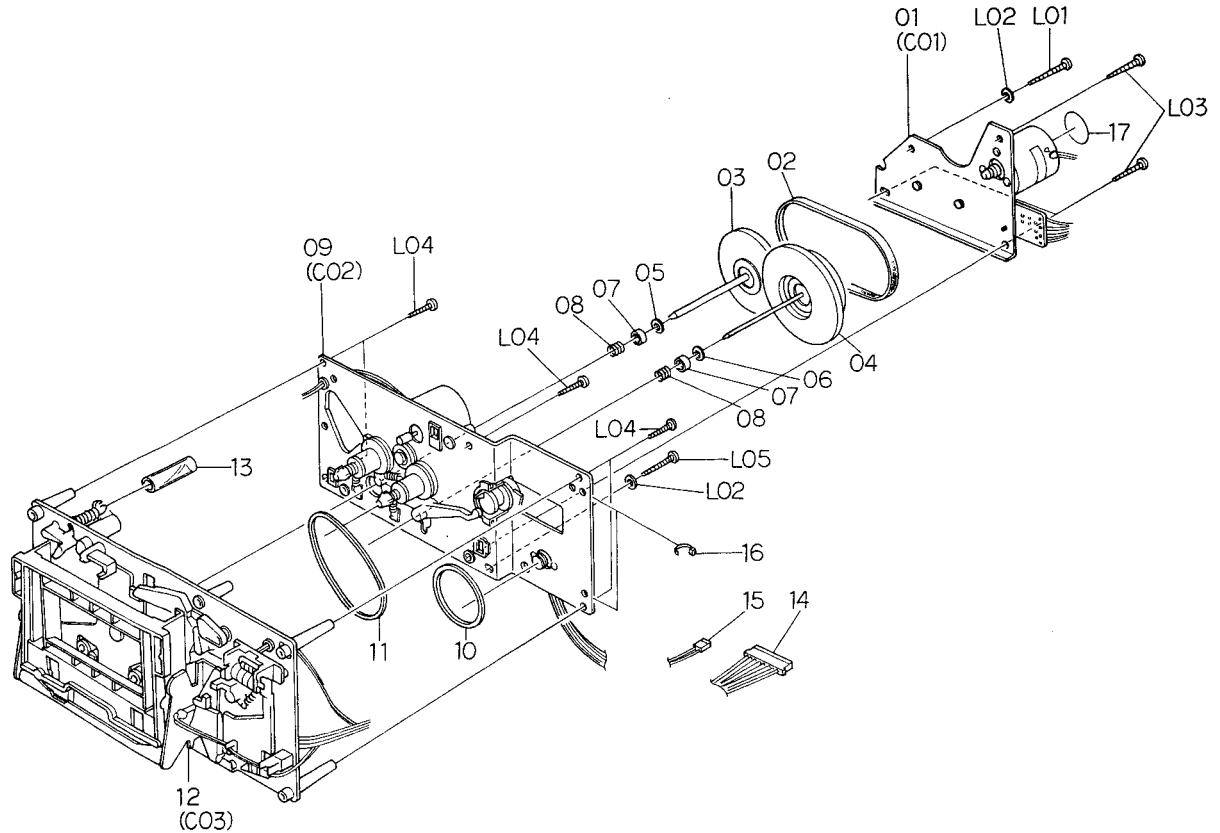

Fig. 8.7

Schematic Ref. No.	Part No.	Description	Q'ty	Schematic Ref. No.	Part No.	Description	Q'ty
B04	CA08312A	Mechanism Ass'y 480Z Serial No.: A30808688 - A30908913 -	1	B04	CA08266A	Mechanism Ass'y 480Z Serial Nos.: A30801001 - A30808687 A30901001 - A30908912	1
01	CA08109B	Flywheel Holder Ass'y	1	01	CA08109B	Flywheel Holder Ass'y	1
02	0C08096C	Capstan Belt	1	02	0C08096C	Capstan Belt	1
03	CA08169A	Supply Flywheel E Ass'y	1	03	CA08169A	Supply Flywheel E Ass'y	1
04	CA08107A	Take-up Flywheel B Ass'y	1	04	CA08107A	Take-up Flywheel B Ass'y	1
05	0C08021B	Thrust Washer 3.1mm	1	05	0C08021B	Thrust Washer 3.1mm	1
06	0C08020B	Thrust Washer 2.6mm	1	06	0C08020B	Thrust Washer 2.6mm	1
07	0C08243A	Flange Thrust Cap	2	07	0C08243A	Flange Thrust Cap	2
08	0C08244A	Flange Thrust Spring	2	08	0C08244A	Flange Thrust Spring	2
09	CA08315A	Sub Mechanism Chassis Ass'y	1	09	CA08232A	Sub Mechanism Chassis Ass'y	1
10	0C08098B	Counter Belt B	1	10	0C08098B	Counter Belt B	1
11	0C08099B	Control Motor Belt	1	11	0C08099B	Control Motor Belt	1
12	CA08269A	Main Mechanism Chassis Ass'y	1	12	CA08269A	Main Mechanism Chassis Ass'y	1
13	0C08151A	Lid Arm Spring Tube	1	13	0C08151A	Lid Arm Spring Tube	1
14	0B08671B	12P-H Connector	1	14	0B08671B	12P-H Connector	1
15	0B08672B	3P-H Connector	1	15	0B08672A	3P-H Connector	1
16	0B08515A	Insu-Lock	9	16	0B08515A	Insu-Lock	9
17	0M03902A	Motor Label	1	17	0M03902A	Motor Label	1
L01	0E00834A	BT Screw M3x30 Philips Pan Head	1	L01	0E00834A	BT Screw M3x30 Philips Pan Head	1
L02	0E00178A	Washer 3mm	2	L02	0E00178A	Washer 3mm	2
L03	0E00833A	BT Screw M3x20 Philips Pan Head	3	L03	0E00833A	BT Screw M3x20 Philips Pan Head	3
L04	0E00883A	BT Screw M3x18 Philips Pan Head	5	L04	0E00883A	BT Screw M3x18 Philips Pan Head	5
L05	0E00835A	BT Screw M3x25 Philips Pan Head	1	L05	0E00835A	BT Screw M3x25 Philips Pan Head	1

8.8. Chassis Ass'y (B05)

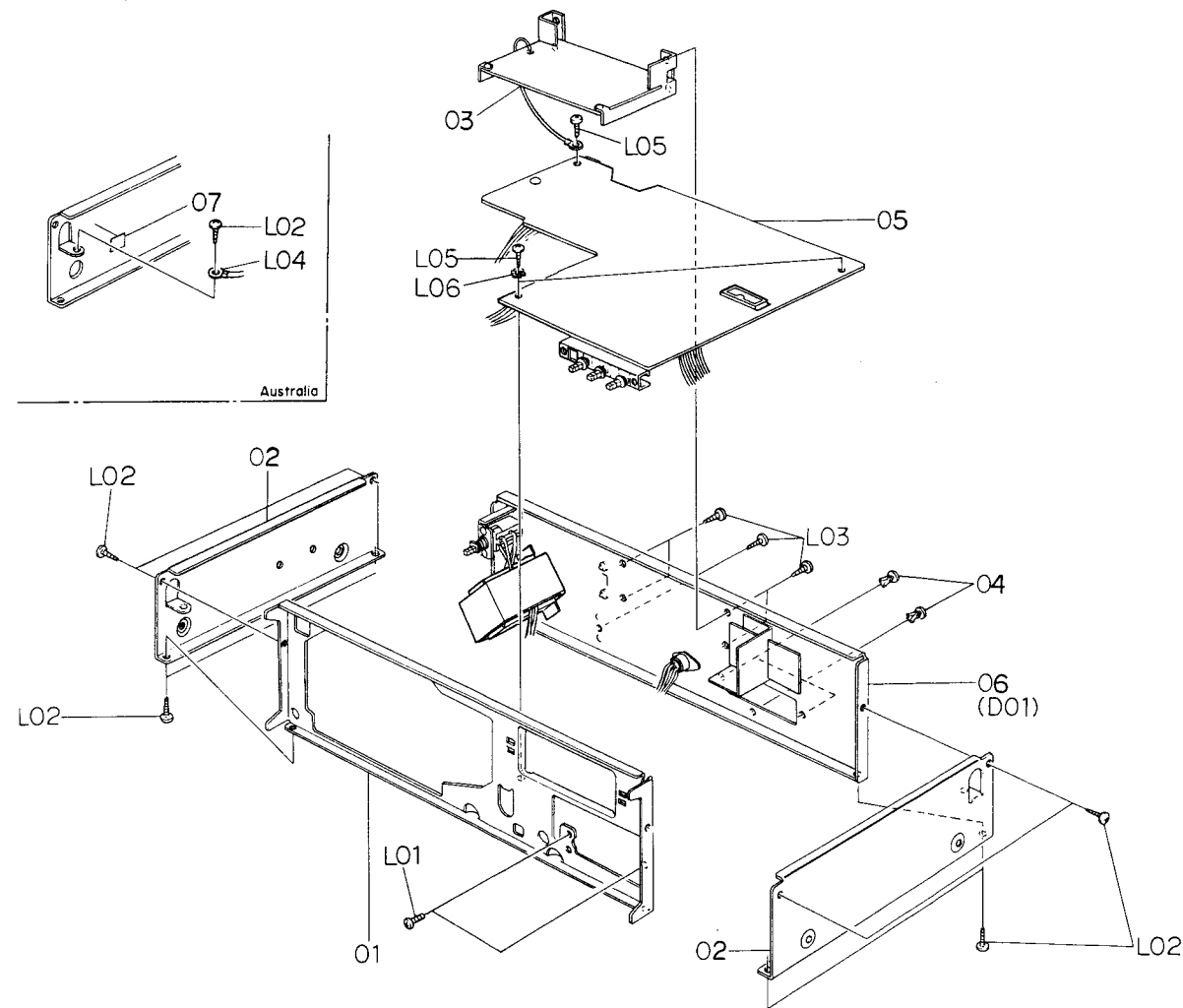

Fig. 8.8

8.9. Flywheel Holder Ass'y (C01)

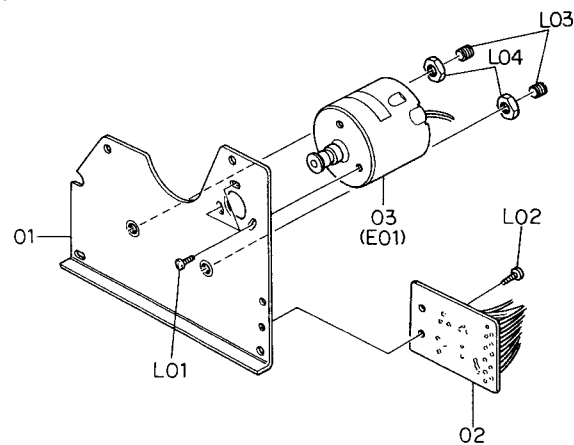

Fig. 8.9

Schematic Ref. No.	Part No.	Description	Q'ty	Schematic Ref. No.	Part No.	Description	Q'ty
B05	JA03784B	Chassis Ass'y (U.S.A. & Canada)	1	B05	JA03784A	Chassis Ass'y (U.S.A. & Canada)	1
	JA03785B	Chassis Ass'y (Japan)	1		JA03785A	Chassis Ass'y (Japan)	1
	JA03788B	Chassis Ass'y (220V Class 2)	1		JA03788A	Chassis Ass'y (220V Class 2)	1
	JA03783B	Chassis Ass'y (UK)	1		JA03783A	Chassis Ass'y (UK)	1
	JA03787B	Chassis Ass'y (Australia)	1		JA03787A	Chassis Ass'y (Australia)	1
	JA03786B	Chassis Ass'y (Others)	1		JA03786A	Chassis Ass'y (Others)	1
		Serial No.:				Serial Nos.:	
		A30808688 -				A30801001 - A30808687	
		A30908913 -				A30901001 - A30908912	
01	OJ04300A	Front Chassis	1	01	OJ04300A	Front Chassis	1
02	OJ04069C	Side Chassis	2	02	OJ04069C	Side Chassis	2
03	BA04512A	Logic P.C.B. Ass'y	1	03	BA04414A	Logic P.C.B. Ass'y	1
04	0B08720A	Plastic Rivet	3	04	0B08720A	Plastic Rivet	3
05	BA04320A	Main P.C.B. Ass'y (U.S.A. & Canada)	1	05	BA04320A	Main P.C.B. Ass'y (U.S.A. & Canada)	1
	BA04319A	Main P.C.B. Ass'y (Japan)	1		BA04319A	Main P.C.B. Ass'y (Japan)	1
	BA04351A	Main P.C.B. Ass'y (220V Class 2)	1		BA04351A	Main P.C.B. Ass'y (220V Class 2)	1
	BA04253A	Main P.C.B. Ass'y (UK)	1		BA04253A	Main P.C.B. Ass'y (UK)	1
	BA04352A	Main P.C.B. Ass'y (Australia)	1		BA04352A	Main P.C.B. Ass'y (Australia)	1
	BA04353A	Main P.C.B. Ass'y (Others)	1		BA04353A	Main P.C.B. Ass'y (Others)	1
06	HA04078A	Rear Panel Ass'y (U.S.A. & Canada)	1	06	HA04078A	Rear Panel Ass'y (U.S.A. & Canada)	1
	HA04079A	Rear Panel Ass'y (Japan)	1		HA04079A	Rear Panel Ass'y (Japan)	1
	HA04082A	Rear Panel Ass'y (220V Class 2)	1		HA04082A	Rear Panel Ass'y (220V Class 2)	1
	HA04077A	Rear Panel Ass'y (UK)	1		HA04077A	Rear Panel Ass'y (UK)	1
	HA04081A	Rear Panel Ass'y (Australia)	1		HA04081A	Rear Panel Ass'y (Australia)	1
	HA04080A	Rear Panel Ass'y (Others)	1		HA04080A	Rear Panel Ass'y (Others)	1
*07	0M03700A	Earth Mark Label	1	*07	0M03700A	Earth Mark Label	1
L01	0E00502A	Screw M3x5 Philips Pan Head	2	L01	0E00502A	Screw M3x5 Philips Pan Head	2
*L02	0E00857A	BT Screw M3x6 Philips Binding Head	8	*L02	0E00857A	BT Screw M3x6 Philips Binding Head	8
L03	0E00860A	BT Screw M3x6 Philips Binding Head (Black Chromate)	5	L03	0E00860A	BT Screw M3x6 Philips Binding Head (Black Chromate)	5
*L04	0E00037A	Earth Lug B-5	1	*L04	0E00037A	Earth Lug B-5	1
L05	0E00868A	BT Screw M3x8 Philips Binding Head	3	L05	0E00868A	BT Screw M3x8 Philips Binding Head	3
L06	0E00172A	Washer 3mm Toothed Lock	2	L06	0E00172A	Washer 3mm Toothed Lock	2
		*: Depends on the versions.				*: Depends on the versions.	
				C01	CA08109B	Flywheel Holder Ass'y Serial No.:	1
						A308.901001 -	
				01	0C08013I	Flywheel Holder	1
				02	BA04126A	Control P.C.B. Ass'y	1
				03	CA08118B	Capstan Motor Ass'y	1
				L01	0E00226A	Screw M2.6x4 Philips Pan Head	3
				L02	0E00834A	BT Screw M3x5 Philips Pan Head	1
				L03	0C08068C	Thrust Screw	2
				L04	0C03857A	Lock Nut	2

8.10. Sub Mechanism Chassis Ass'y (C02)

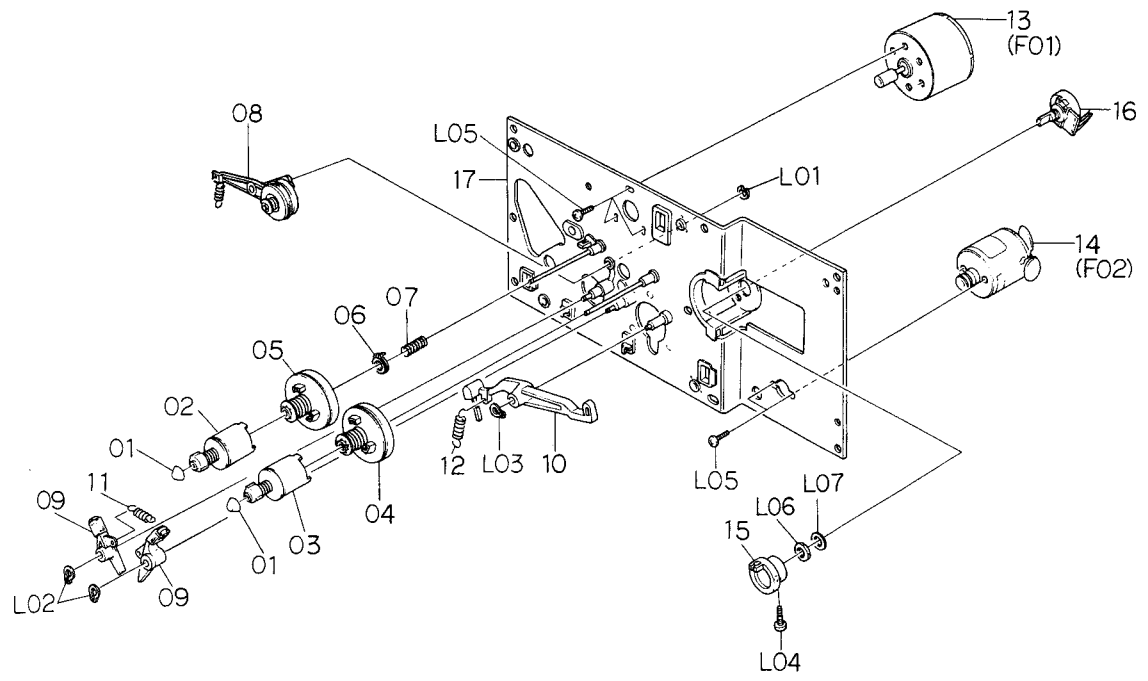

Fig. 8.10.1 Serial No.: A30808688 –
Serial No.: A30908913 –

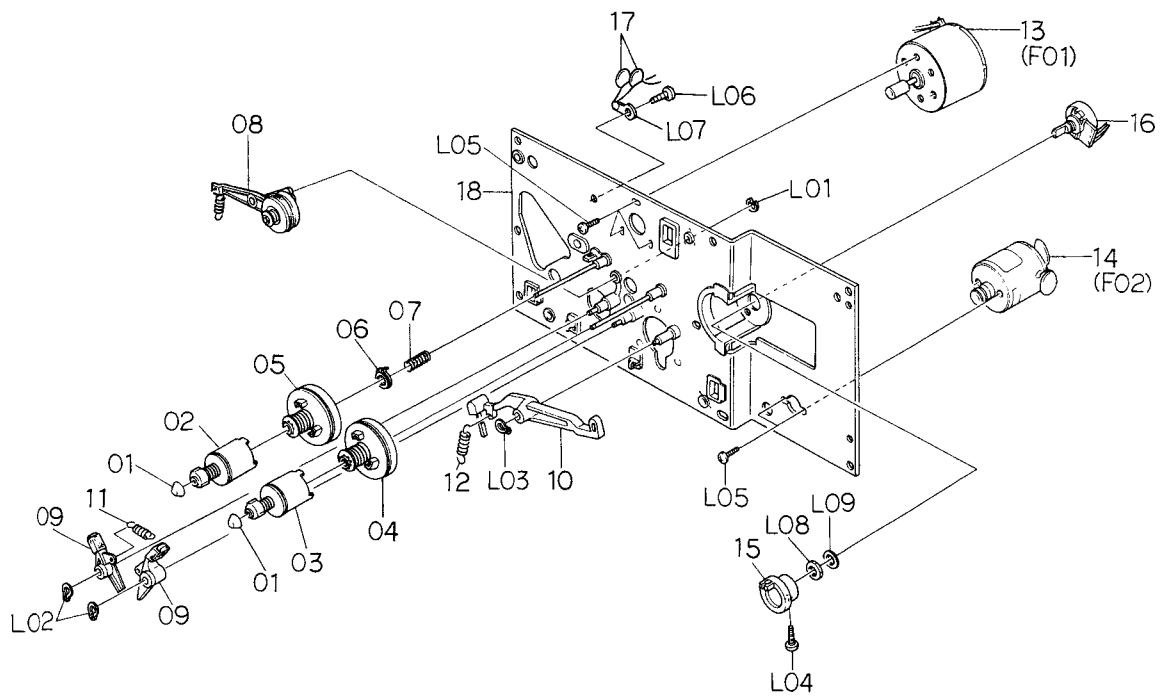

Fig. 8.10.2 Serial Nos.: A30801001 – A30808687
Serial Nos.: A30901001 – A30908912

Schematic Ref. No.	Part No.	Description	Q'ty	Schematic Ref. No.	Part No.	Description	Q'ty		
C02	CA08315A	Sub Mechanism Chassis Ass'y Serial No.: A30808688 – A30908913 –	1	L07	0E00037A	Earth Lug B-5	1		
	01	0C08039B	Reel Hub Head	2	L08	–	Volume Nut	(1)	
	02	CA08197A	Reel Hub B Supply Ass'y	1	L09	–	Volume Washer	(1)	
	03	CA08038B	Reel Hub B Take-up Ass'y	1	C03	CA08269A	Main Mechanism Chassis Ass'y Serial No.: A308.901001 –	1	
	04	CA08037A	Reel hub Take-up Ass'y	1		01	CA08141A	Cassette Case Holder L Ass'y	1
	05	CA08064A	Reel hub Supply Ass'y	1		02	CA08022A	Cassette Case Holder R Ass'y	1
	06	CA08039A	Back Tension Ass'y	1		03	CA08111A	Cassette Case Ass'y	1
	07	0C08269A	Back Tension Spring	1		04	CA08120A	Head Mount Base Ass'y	1
	08	CA08193A	Idler Arm Ass'y	1		05	0C08121A	Take-up Pressure Roller Spring	1
	09	CA08042A	Brake Arm Ass'y	2		06	0C08250A	Supply Pressure Roller Spring	1
	10	0C08030C	Brake Drive Arm	1		07	CA08053B	Supply Pressure Roller Ass'y	1
	11	0C08129A	Brake Arm Spring	1		08	0C08122B	Supply Pressure Roller Thrust Spring	1
	12	0C08128A	Brake Drive Arm Spring	1		09	CA08079B	Take-up Pressure Roller Ass'y	1
	13	CA08242A	Reel Motor Ass'y	1		10	0C08183B	Take-up Pressure Roller Thrust Spring	1
	14	CA08124A	Control Motor Ass'y	1		11	CA08121A	Head Base Ass'y C	1
	15	0C08053B	Volume Coupler	1		12	0C08182A	Pressure Roller Drive Bar	1
	16	0B07240A	Volume Control 10K (B)	1		13	0C08086B	Head Base Roller	3
17	CA08194A	Sub Chassis Ass'y	1	14		0C08050B	Record Sensor	1	
L01	0E00698A	E-Ring 2.5mm	1	15		0C08051E	Cassette Hold Arm	1	
L02	0E00837A	Stopper Ring 3mm	2	16		0C08120A	Cassette Hold Arm Spring	1	
L03	0E00838A	Stopper Ring 4mm	1	17	CA08196A	Back Tension Arm Ass'y	1		
L04	0E00859A	BT Screw M2.6x6 Philips Binding Head	1	18	0C08254A	Sleeve	1		
L05	0E00226A	Screw M2.6x4 Philips Pan Head	5	19	CA08027A	Head Base Drive Arm Ass'y	1		
L06	–	Volume Nut	(1)	20	0C08143C	Head Base Drive Arm Spring	1		
L07	–	Volume Washer	(1)	21	CA08025A	Record Arm Ass'y	1		
C02	CA08232A	Sub Mechanism Chassis Ass'y Serial Nos.: A30801001 – A30808687 A30901001 – A30908912	1	22	0C08038D	Record Trigger	1		
	01	0C08039B	Reel Hub Head	2	23	0C08112A	Flip-Flop Spring	1	
	02	CA08197A	Reel Hub B Supply Ass'y	1	24	CA08026A	Pressure Roller Drive Arm Ass'y	1	
	03	CA08038B	Reel Hub B Take-up Ass'y	1	25	0C08071D	Counter Reset Arm	1	
	04	CA08037A	Reel hub Take-up Ass'y	1	26	0C08124B	Eject Linkage Wire	1	
	05	CA08064A	Reel hub Supply Ass'y	1	27	0C08057E	Eject Arm	1	
	06	CA08039A	Back Tension Ass'y	1	28	0C08078B	Arm Shaft	1	
	07	0C08269A	Back Tension Spring	1	29	CA08237A	Auto Shut-off Ass'y	1	
	08	CA08193A	Idler Arm Ass'y	1	30	CA08020A	Counter Ass'y	1	
	09	CA08042A	Brake Arm Ass'y	2	31	0C08097B	Counter Belt A	1	
	10	0C08030C	Brake Drive Arm	1	32	0C08067C	Eject Stopper	1	
	11	0C08129A	Brake Arm Spring	1	33	0C08134C	Eject Stopper Spring	1	
	12	0C08128A	Brake Drive Arm Spring	1	34	0C08119A	Record Protector	1	
	13	CA08117B	Reel Motor Ass'y	1	35	0C08194C	Damper Lock Arm	1	
	14	CA08124A	Control Motor Ass'y	1	36	0C08153A	Damper Arm Spring Tube	1	
	15	0C08053B	Volume Coupler	1	37	0C08116A	Record Arm Spring	2	
	16	0B07240A	Volume Control 10K (B)	1	38	CA08030A	Pneumatic Damper Ass'y	1	
17	0B09290A	Ceramic Capacitor 0.01μ 50V Z	2	39	CA08023A	Supply Capstan Flange Ass'y	1		
18	CA08194A	Sub Chassis Ass'y	1	40	CA08024A	Take-up Capstan Flange Ass'y	1		
L01	0E00698A	E-Ring 2.5mm	1	41	0C08186A	Cam Drive Gear	1		
L02	0E00837A	Stopper Ring 3mm	2	42	0C08029H	Control Cam	1		
L03	0E00838A	Stopper Ring 4mm	1	43	0C08152A	Counter-Load Arm Spring Tube	1		
L04	0E00859A	BT Screw M2.6x6 Philips Binding Head	1	44	0C08117A	Counter-Load Arm Spring	1		
L05	0E00226A	Screw M2.6x4 Philips Pan Head	5	45	CA08028A	Counter-Load Arm Ass'y	1		
L06	0E00843A	BT Screw M2.6x4 Philips Pan Head	1	46	0C08123B	Record Switch Linkage Wire	1		
				47	0C08037E	Record Arm B	1		
				48	CA08183A	Main Chassis Ass'y	1		
				L01	0E00837A	Stopper Ring 3mm	13		
				L02	0E00834A	BT Screw M3x30 Philips Pan Head	2		
				L03	0E00831A	BT Screw M3x10 Philips Pan Head	4		

8.11. Main Mechanism Chassis Ass'y (C03)

Schematic Ref. No.	Part No.	Description	Q'ty
L04	0E00254A	Washer 3.1mm Plastics	2
L05	0E00222A	E-Ring 2mm	2
L06	0E00839A	Stopper Ring 2.5mm	2
L07	0E00876A	BT Screw M2.6x8 Philips Pan Head	11
L08	0C08060B	Height Adjustment Nut	2
L09	0E00142A	Washer 2.6mm	2
L10	0E00879A	BT Screw M2x15 Philips Pan Head	1
L11	0E00838A	Stopper Ring 4mm	3
L12	0E00846A	BT Screw M3x8 Philips Pan Head	3
L13	0E00895A	Earth Lug 3mm	2
L14	0E00859A	BT Screw M2.6x6 Philips Binding Head	1
L15	0C08255A	Washer 2.6mm	1

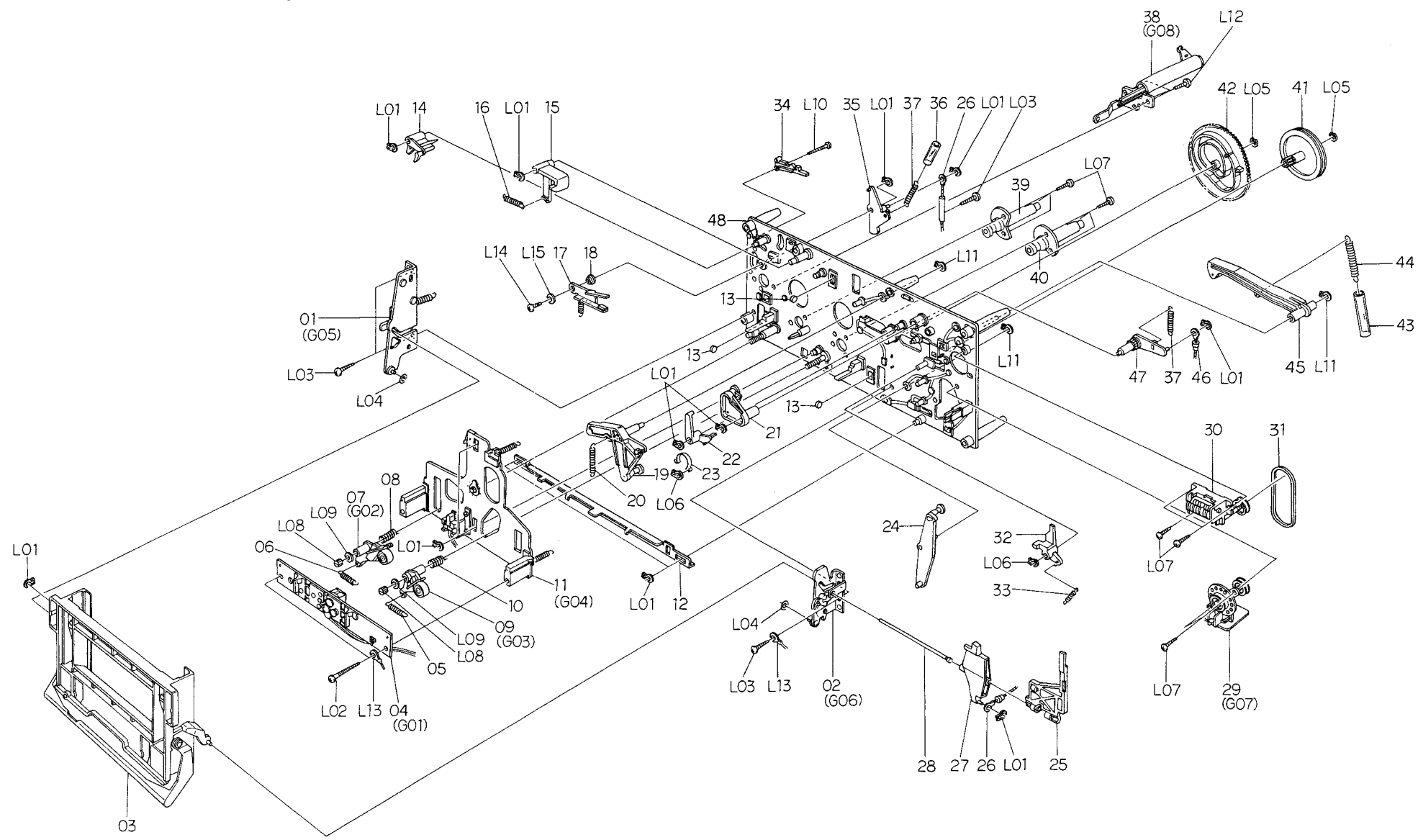

Fig. 8.11

8.12. Rear Panel Ass'y (D01)

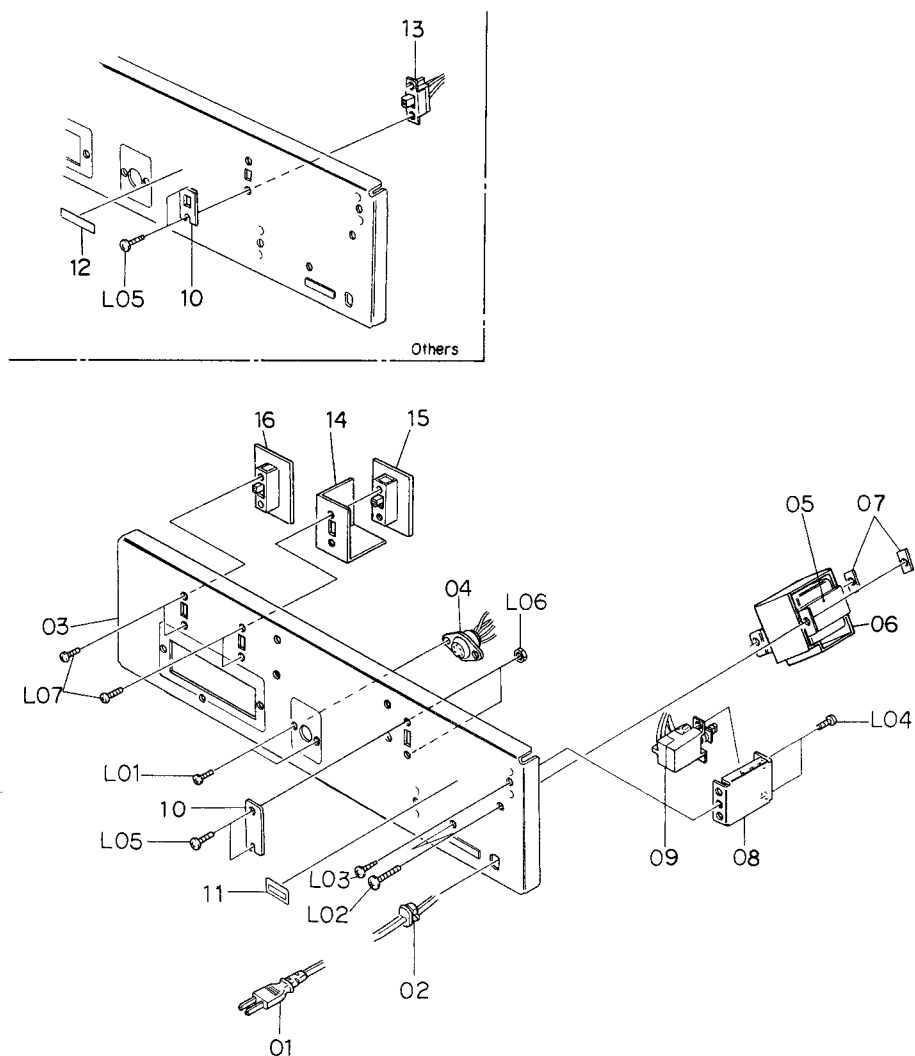

Fig. 8.12

Schematic Ref. No.	Part No.	Description	Q'ty	Schematic Ref. No.	Part No.	Description	Q'ty				
D01	HA04078A	Rear Panel Ass'y (U.S.A. & Canada)	1	L03	0E00860A	BT Screw M3x6 Philips Binding Head (Black Chromate)	1				
	HA04079A	Rear Panel Ass'y (Japan)	1	L04	0E00502A	Screw M3x5 Philips Pan Head	2				
	HA04082A	Rear Panel Ass'y (220V Class 2)	1	L05	0E00593A	Screw M3x6 Philips Binding Head (Bronze)	2				
	HA04077A	Rear Panel Ass'y (UK)	1	L06	0E00507A	Nut Hex. M3	2				
	HA04081A	Rear Panel Ass'y (Australia)	1	L07	0E00945A	Screw M2.6x4 Philips Binding Head (Black Chromate)	4				
	HA04080A	Rear Panel Ass'y (Others) Serial No.: A308.901001 -	1	-	0J03644A	Chobert Rivet	2				
01	0B08533A	Power Cord (U.S.A., Canada & Others)	1	E01	CA08118B	Capstan Motor Ass'y Serial No.: A308.901001 -	1				
	0B08219U	Power Cord (Japan)	1								
	0B08093U	Power Cord (220V Class 2)	1								
02	0B08348A	Power Cord (UK)	1	01	0C08219A	Capstan Motor	1				
	0B08666A	Power Cord (Australia)	1	02	0C08212C	Motor Pulley	1				
	0B08037U	Cord Bushing (U.S.A., Canada, Japan, 220V Class 2 & Others)	1	03	0M04077A	Motor Seal	1				
03	0B08351A	Cord Bushing 4K-4 (UK)	1	F01	CA08242A	Reel Motor Ass'y Serial No.: A30808688 - A30908913 -	1				
	0B08325U	Cord Bushing (Australia)	1								
	0H03936A	Rear Panel	1								
04	0B08687A	6P DIN Socket	1	01	0C08272A	Reel Motor	1				
05	0B06652A	Power Transformer (U.S.A. & Canada)	1								
02	0B06653B	Power Transformer (Japan)	1								
06	0B06673A	Power Transformer (220V Class 2 & UK)	1	02	0C08063F	Reel Motor Pulley	1				
	0B06656B	Power Transformer (Australia)	1								
	0B06654B	Power Transformer (Others)	1								
07	0J04426B	Power Transformer Shield Cover	1	03	0B09290A	Ceramic Capacitor 0.01μ 50V Z	1				
08	0C01162B	Bolt Receptacle Plate	1								
09	0J04076A	Power Switch Holder	1								
10	0B07299A	Power Switch (U.S.A. & Canada)	1	F01	CA08117B	Reel Motor Ass'y Serial Nos.: A30801001 - A30808687 A30901001 - A30908912	1				
	0B07301A	Power Switch (Japan)	1								
	0B07252A	Power Switch (220V Class 2, UK, Australia & Others)	1								
11	0J03663C	Switch Cover (U.S.A., Canada, Japan, 220V Class 2, UK & Australia)	1	01	0C08218A	Reel Motor	1				
	0M03946A	Voltage Selector Lock Plate C (Others)	1								
	0M03551B	Pass Label	1								
12	0M03794A	Voltage Label 100V (Japan)	1	02	0C08063F	Reel Motor Pulley	1				
	0M03796A	Voltage Label 220V (220V Class 2)	1								
	0M03797A	Voltage Label 240V (UK & Australia)	1								
13	0M03955A	Voltage Label 120V/220-240V (Others)	1	F02	CA08124A	Control Motor Ass'y Serial No.: A308.901001 -	1				
	0B07092U	Voltage Selector (Others)	1								
	0J04389A	Headphone Switch Shield Plate	1								
14	BA04420A	Headphone Switch P.C.B. Ass'y	1	01	0C08137A	Control Motor	1				
	BA04402A	MPX Filter Switch P.C.B. Ass'y	1								
	0M03905A	UL Label	1								
15	0M04214A	Serial Number Plate	1	02	0C08064A	Control Motor Pulley	1				
	0M04097B	Fuse Caution Label (U.S.A. & Canada)	1								
	0M03844B	Power Cord Label (UK)	1								
16	0E00714A	Screw M2.6x6 Philips Binding Head (Bronze)	2	03	0B09292A	Ceramic Capacitor 0.1μ 50V Z	2				
	L01	0E00714A	Screw M2.6x6 Philips Binding Head (Bronze)					2			
	L02	0E00756A	Screw M4x8 Philips Binding Head (Bronze)					2			
L01	0E00714A	Screw M2.6x6 Philips Binding Head (Bronze)	2	04	0C08161B	Spring Stopper	1				
								L02	0E00756A	Screw M4x8 Philips Binding Head (Bronze)	2
06	CA08083C	Head Mount Base Sub Ass'y	1								
				07	CA08311A	RP-9E Record/Playback Head Ass'y	1				

8.13. Capstan Motor Ass'y (E01)

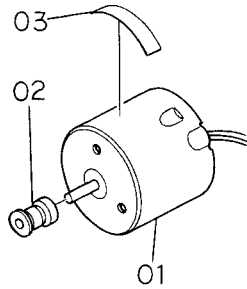

Fig. 8.13

8.14. Reel Motor Ass'y (F01)

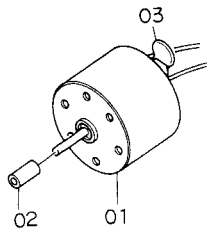

Fig. 8.14.1

Serial No.: A30808688 -

Serial No.: A30908913 -

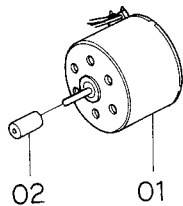

Fig. 8.14.2

Serial Nos.: A30801001 - A30808687

Serial Nos.: A30901001 - A30908912

8.15. Control Motor Ass'y (F02)

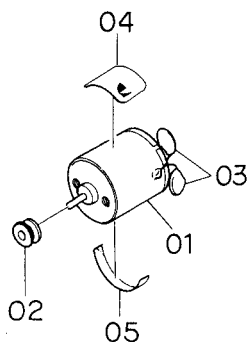

Fig. 8.15

8.16. Head Mount Base Ass'y (G01)

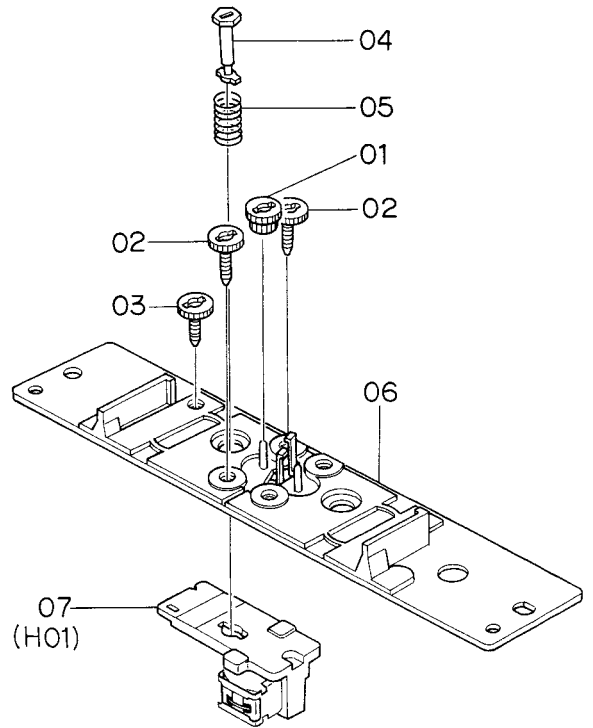

Fig. 8.16

8.17. Supply Pressure Roller Ass'y (G02)

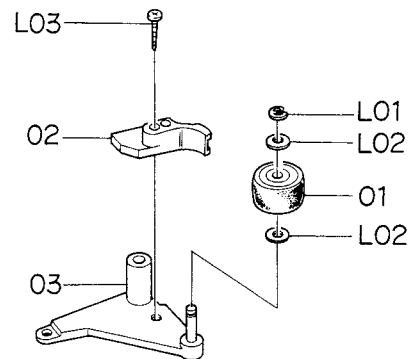

Fig. 8.17

Schematic Ref. No.	Part No.	Description	Q'ty
G02	CA08053B	Supply Pressure Roller Ass'y Serial No.: A308.901001 -	1
01	0C08164G	Pressure Roller	1
02	0C08189C	Supply Tape Guide	1
03	CA08061A	Supply Pressure Roller Arm Ass'y	1
L01	0E00042A	E-Ring 1.5mm	1
L02	0C08024A	Washer 2mm	2
L03	0E00788A	BT Screw M2x8 Philips Pan Head	1

8.18. Take-up Pressure Roller Ass'y (G03)

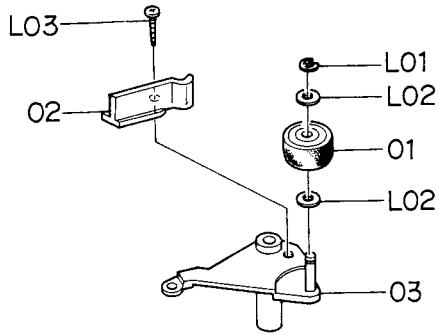

Fig. 8.18

8.19. Head Base Ass'y C (G04)

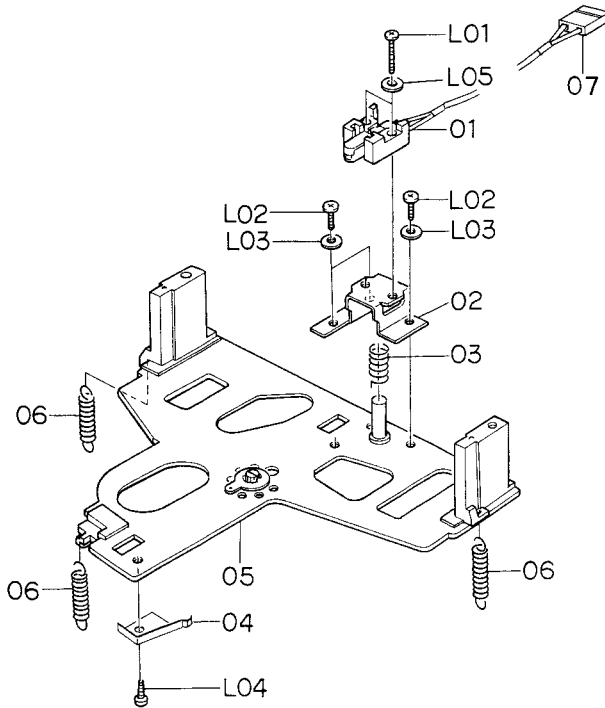

Fig. 8.19

8.20. Cassette Case Holder L Ass'y (G05)

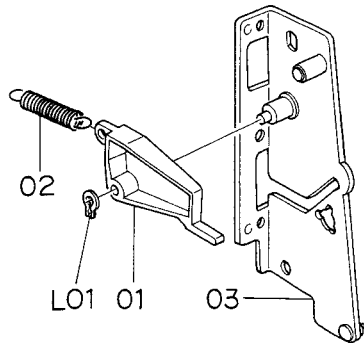

Fig. 8.20

8.21. Cassette Case Holder R Ass'y (G06)

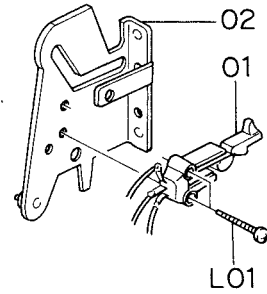

Fig. 8.21

8.22. Auto Shut-off Ass'y (G07)

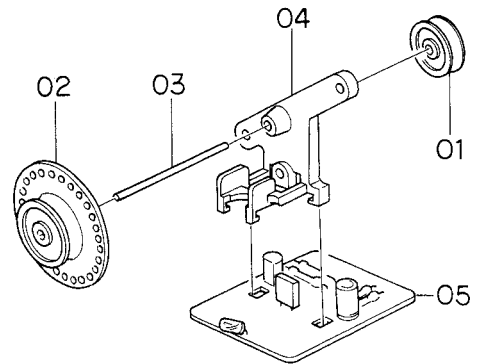

Fig. 8.22

8.23. Pneumatic Damper Ass'y (G08)

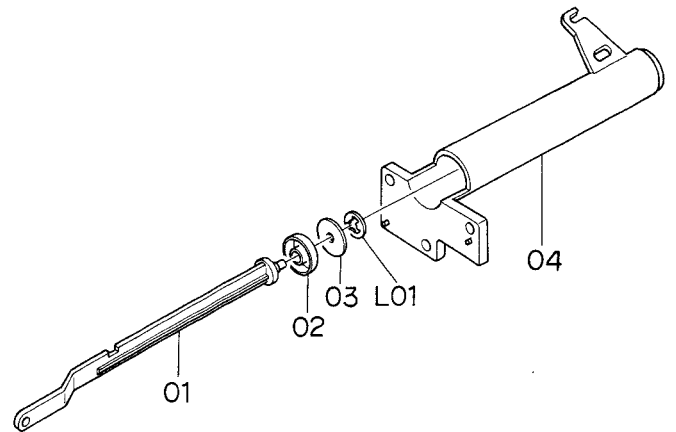

Fig. 8.23

8.24. RP-9E Record/Playback Head Ass'y (H01)

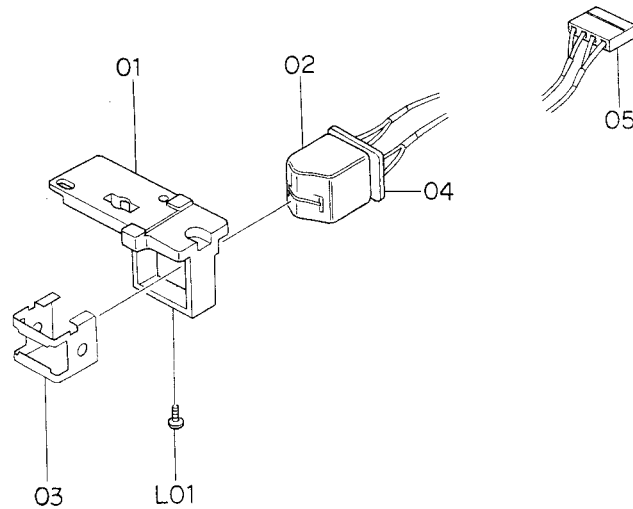

Fig. 8.24

Schematic Ref. No.	Part No.	Description	Q'ty	Schematic Ref. No.	Part No.	Description	Q'ty
G03	CA08079B	Take-up Pressure Roller Ass'y Serial No.: A308.901001 -	1	G06	CA08022A	Cassette Case Holder R Ass'y Serial No.: A308.901001 -	1
01	0C08164G	Pressure Roller	1	01	0C08133A	Eject Sensor	1
02	0C08181C	Take-up Tape Guide	1	02	CA08044A	Cassette Case Holder R Sub Ass'y	1
03	CA08073B	Take-up Pressure Roller Arm Ass'y	1	L01	0E00840A	BT Screw M2x8 Philips Pan Head	2
L01	0E00042A	E-Ring 1.5mm	1	G07	CA08237A	Auto Shut-off Ass'y Serial No.: A308.901001 -	1
L02	0C08024A	Washer 2mm	2	01	0C08047A	Shut-off Pulley A	1
L03	0E00788A	BT Screw M2x8 Philips Pan Head	1	02	0C08206B	Shut-off Pulley B	1
G04	CA08121A	Head Base Ass'y C Serial No.: A308.901001 -	1	03	0C08088B	Shut-off Pulley Shaft	1
01	GA02017A	E-8L Erase Head	1	04	0C08207B	Shut-off Pulley Holder	1
02	0C08158D	EH Hold Plate	1	05	BA04070A	Shut-off P.C.B. Ass'y	1
03	0C08166A	EH Hold Plate Spring	1	G08	CA08030A	Pneumatic Damper Ass'y Serial No.: A308.901001 -	1
04	0C08174D	Cassette Hold Spring	1	01	0C08058C	Damper Piston	1
05	CA08003Q	Head Base Ass'y	1	02	0C08102C	Damper Ring	1
06	0C08175A	Head Base L Spring	3	03	0C08010C	Damper Plate	1
07	0B08679D	2P-H Connector	1	04	0C08059D	Sylinder	1
L01	0E00951A	Screw M1.7x7 Philips Pan Head	2	L01	0E00874A	Stopper Ring CS 2mm	1
L02	0E00909A	Screw M2x6 Philips Pan Head	3	H01	CA08311A	RP-9E Record/Playback Head Ass'y Serial No.: A308.901001 -	1
L03	0E00117A	Washer 2mm	3	01	0C08217A	Head Plate	1
L04	0E00853A	BT Screw M2x3 Philips Pan Head	1	02	0G01294A	RP-9E Record/Playback Head	1
L05	0E00952A	Washer 1.7mm	2	03	0C08216B	Pad Lifter 9E	1
G05	CA08141A	Cassette Case Holder L Ass'y Serial No.: A308.901001 -	1	04	0B07857A	Head Terminal P.C.B.	1
01	0C08073C	Lid Arm A	1	05	0B08678C	4P-H Connector	1
02	0C08114A	Lid Arm Spring	1	L01	0E00887A	Screw M1.7x4 Philips Pan Head	1
03	CA08090F	Cassette Case Holder L Sub Ass'y	1				
L01	0E00837A	Stopper Ring 3mm	1				

9. OVERALL TIMING CHART

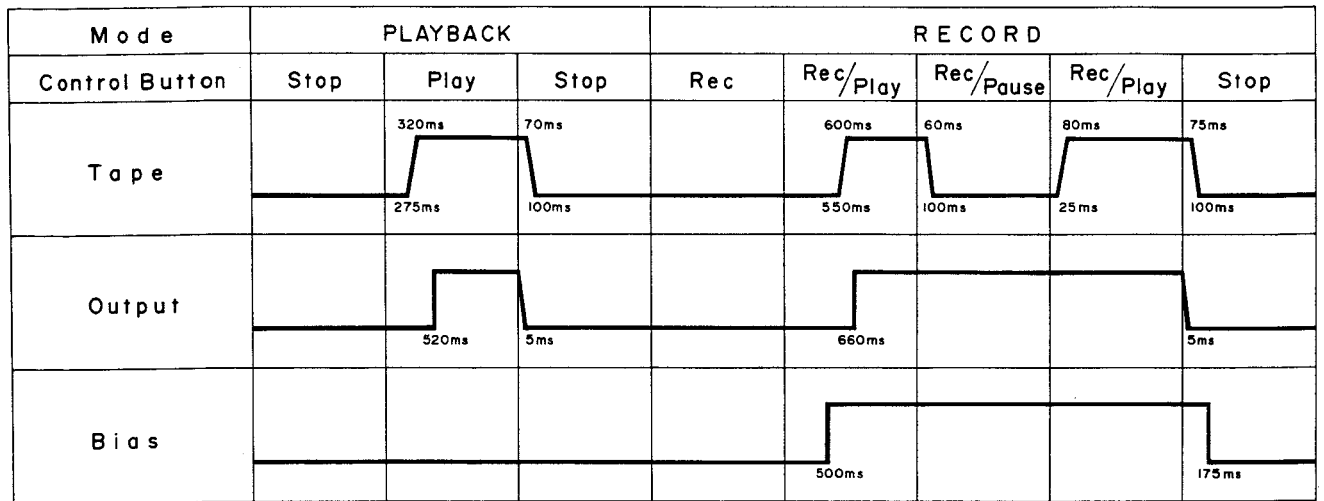

Fig. 9

10. EQ. AMP. FREQUENCY RESPONSE

10.1. Playback Frequency Response

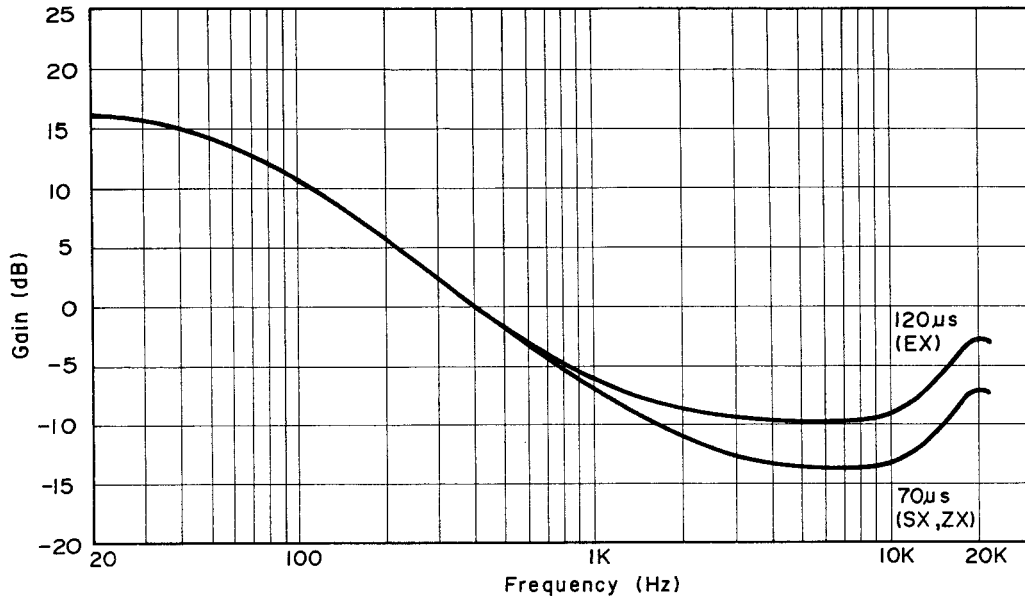

Fig. 10.1

10.2. Record Current Frequency Response

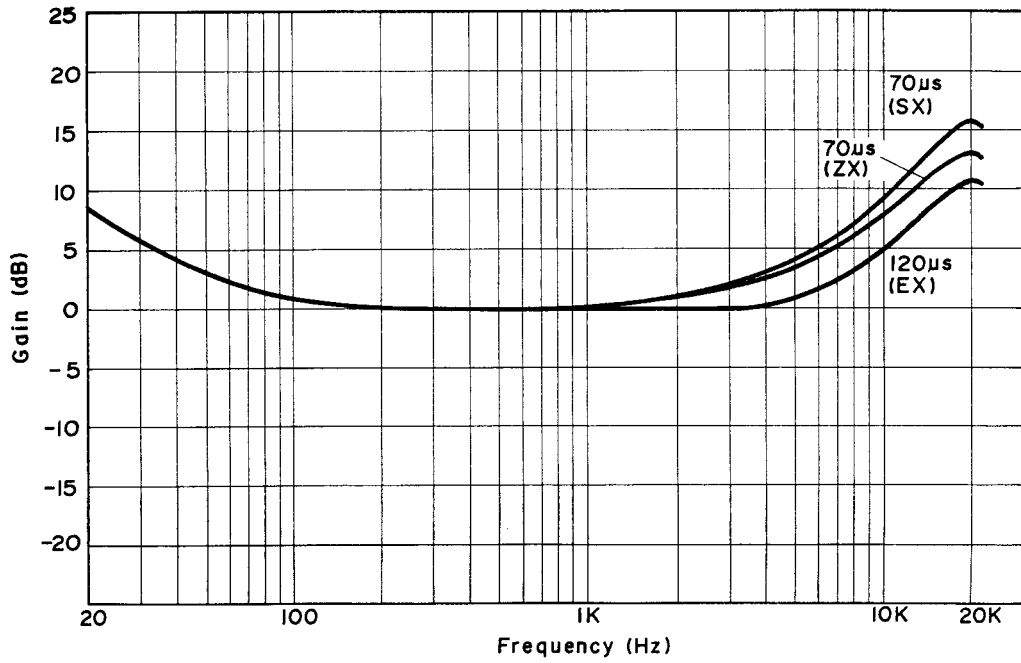
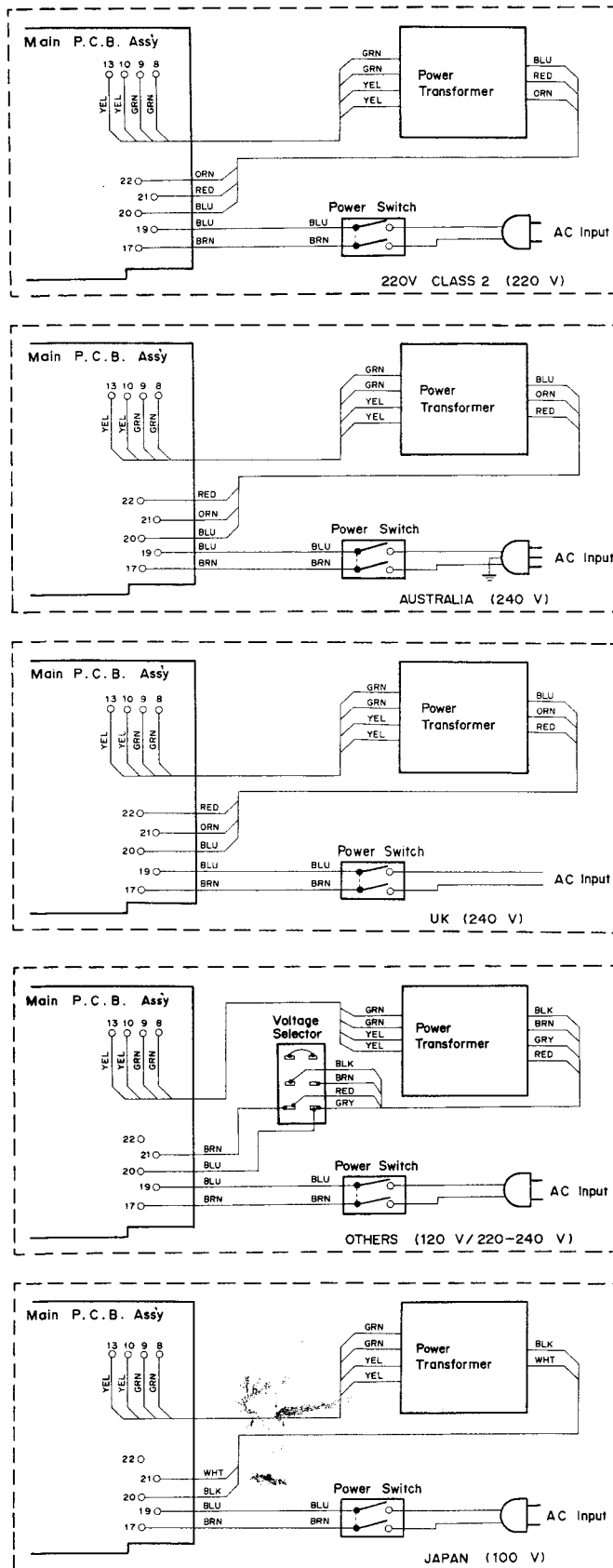

Fig. 10.2

11. WIRING DIAGRAM



Notes: 1. Table of wire colors

- BLK – Black
- BLU – Blue
- ORN – Orange
- GRY – Gray
- GRN – Green
- RED – Red
- BRN – Brown
- YEL – Yellow
- WHT – White
- VIO – Violet

2. Component side view of the P.C.B. is illustrated unless otherwise specified.

Fig. 11.1

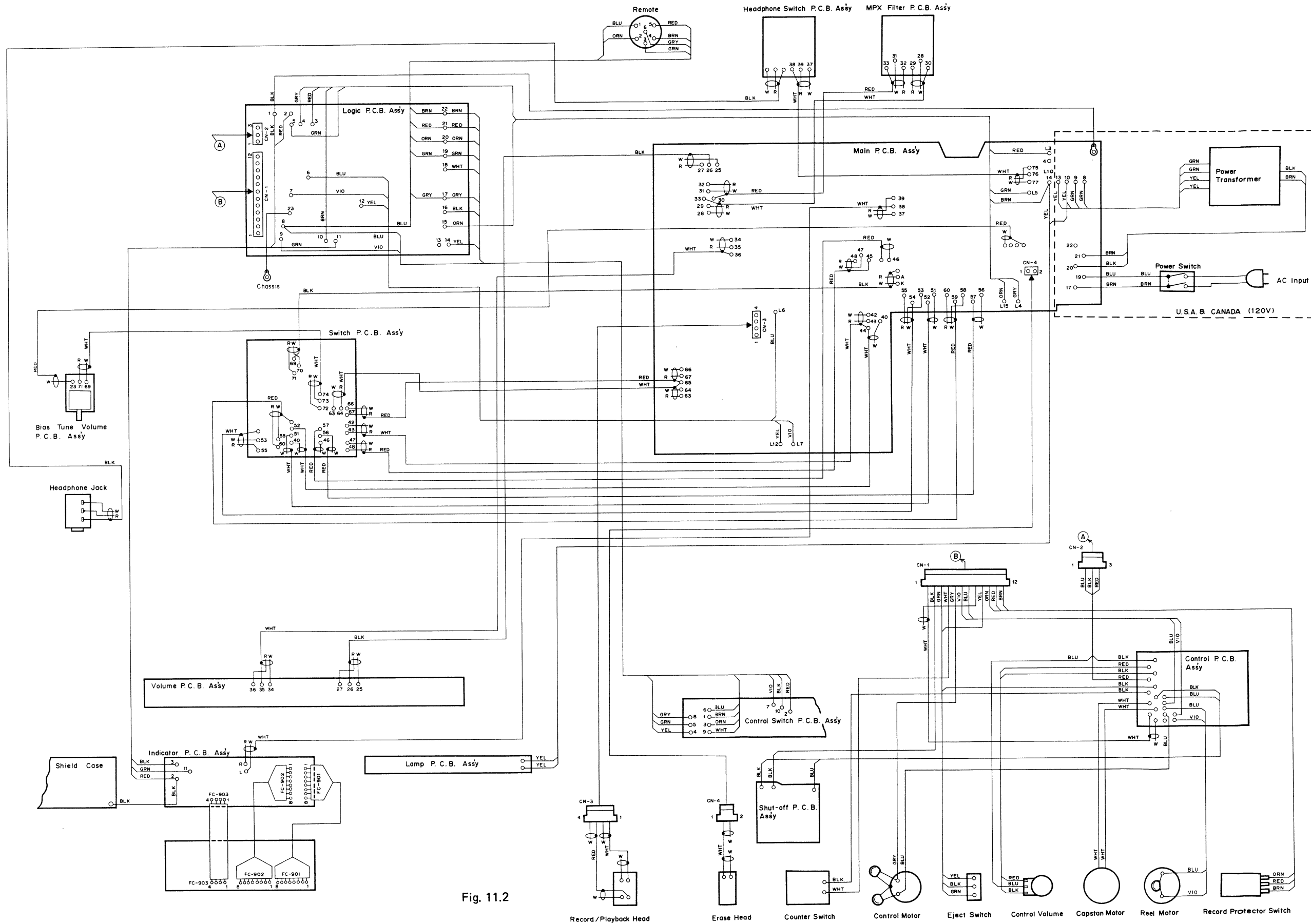

Fig. 11.2

12. BLOCK DIAGRAMS

12.1. Amplifier Section

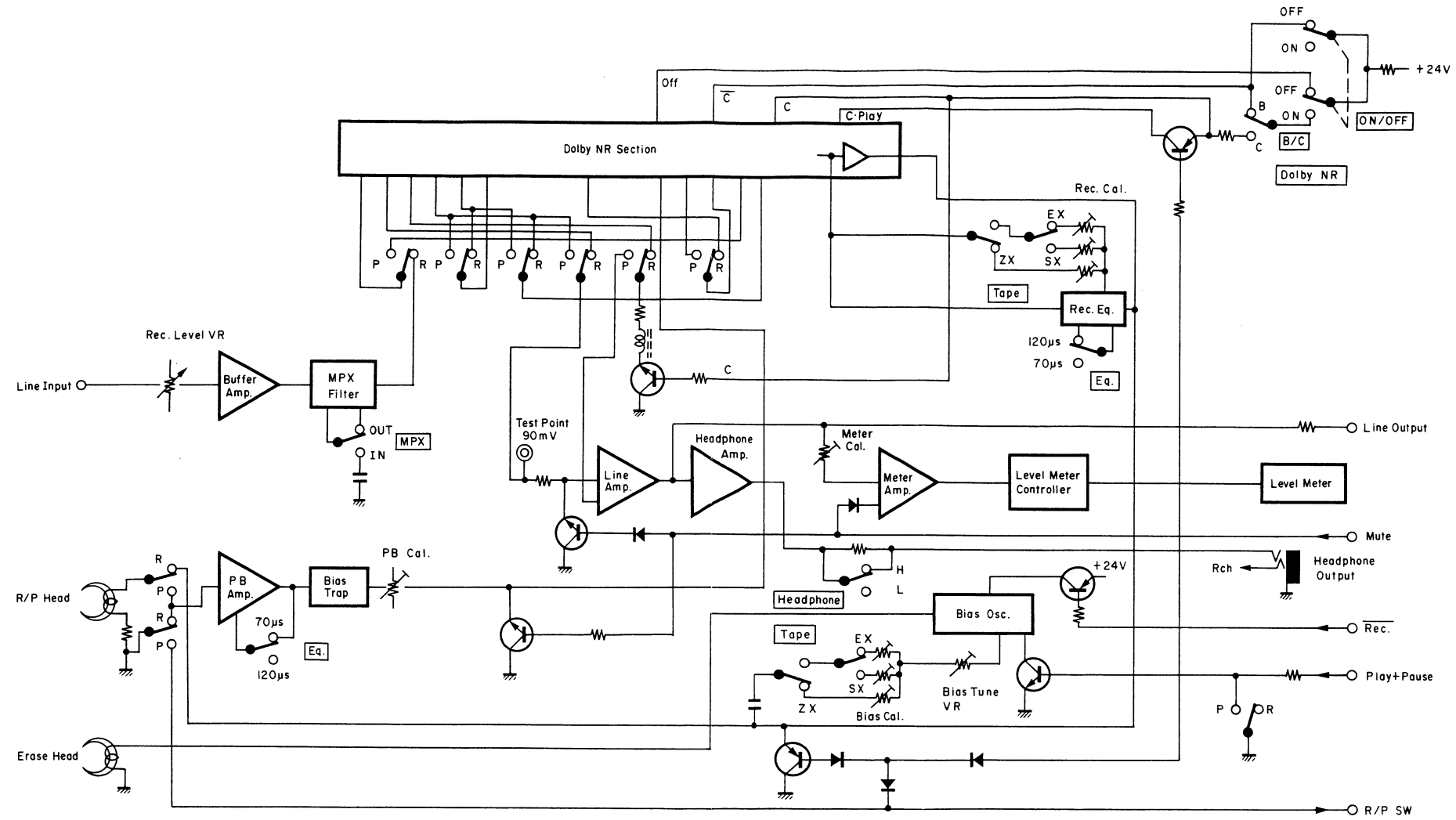

Fig. 12.1

12.2. Mechanism Control Section

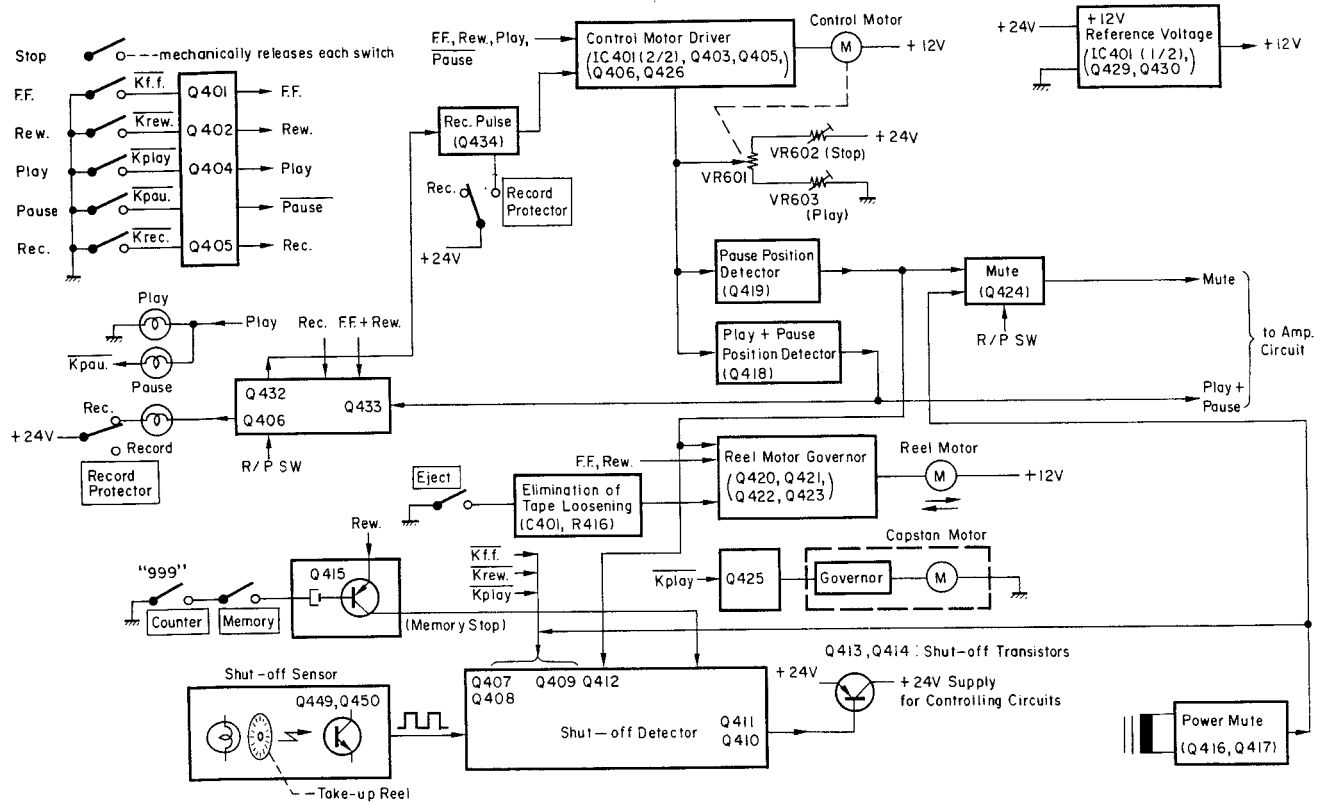

Fig. 12.2

13. SCHEMATIC DIAGRAMS

13.1. IC Block Diagrams

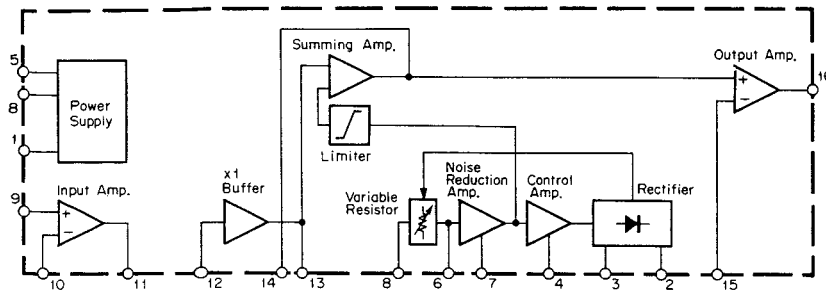

Fig. 13.1 Dolby NR IC μ A7300PC

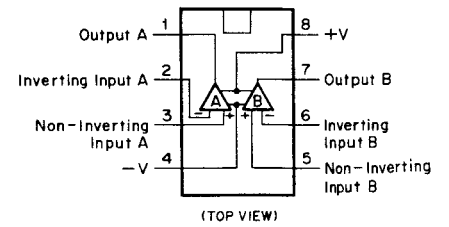

Fig. 13.2 Operational Amp. IC 4558

13.2. Attention to Servicemen

(1) Parts Replacement

Following parts shall be replaced with the specified ones.
Refer to the parts list.

(a) Power Supply Circuit

Power Cord
Power Transformer T1
Power Switch SW1

(b) Main P.C.B. Ass'y

F401, 402
M2, 3
D401
IC401
R301, 303, 304, 305, 306, 307, 308, 311, 312
716, 717, 816, 817

(c) Logic P.C.B. Ass'y

O402, 413, 420, 421, 425, 427, 428, 429, 430
R453, 470

(d) Control Switch P.C.B. Ass'y

R610, 611, 612
PL601, 602, 603

(e) Shut-off P.C.B. Ass'y

R605
PL407

(f) Lamp P.C.B. Ass'y

PL001, 002

(g) Indicator P.C.B. Ass'y

R901

(2) Insulation Check

Before returning the repaired N-480Z to a customer, check to insure that the exposed part is accurately insulated from the AC line by measuring the leakage current or the insulation resistance between them.

13.3. Mechanism Control Section

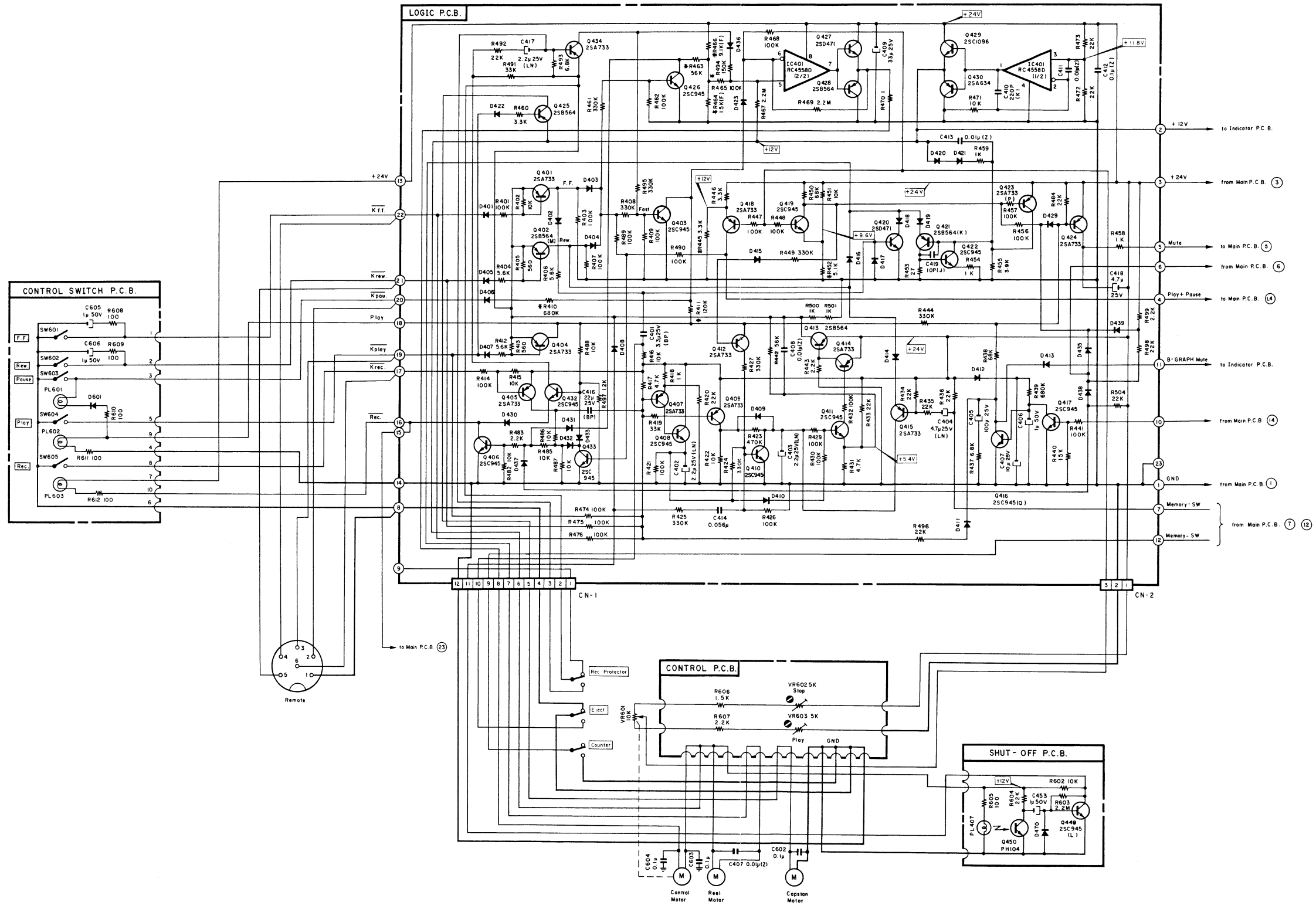

Fig. 13.3.1 Serial No.: A30808688 –
 Serial No.: A30908913 –

Notes: 1. Diode is 1S53, 1S953, or 1S1555 unless otherwise specified.
 2. Resistor and capacitor marked with * show typical value.

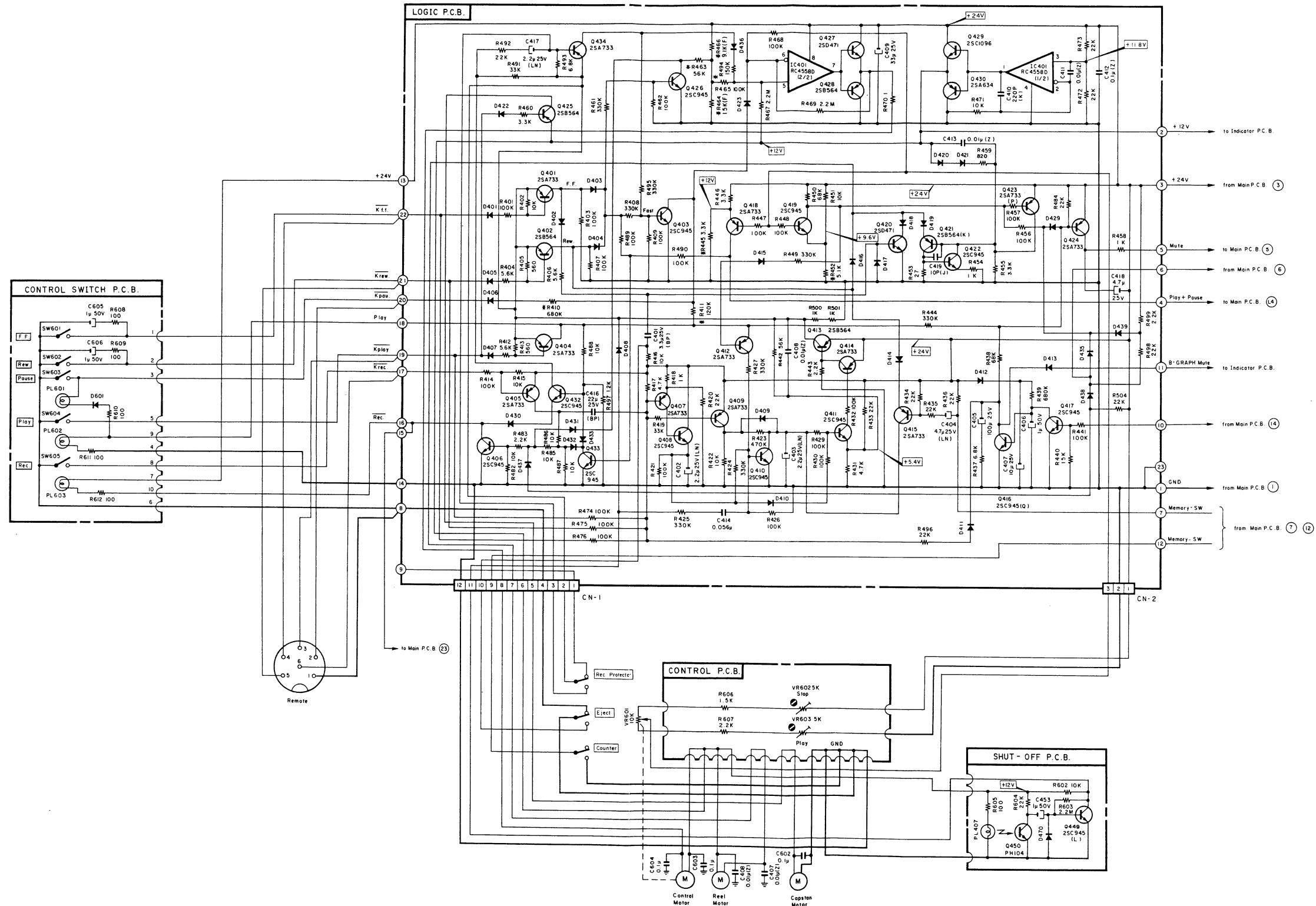

Fig. 13.3.2 Serial Nos.: A30801001 – A30808687
Serial Nos.: A30901001 – A30908912

Notes: 1. Diode is 1SS53, 1S953, or 1S1555 unless otherwise specified.
2. Resistor and capacitor marked with * show typical value.

13.4. Amplifier Section

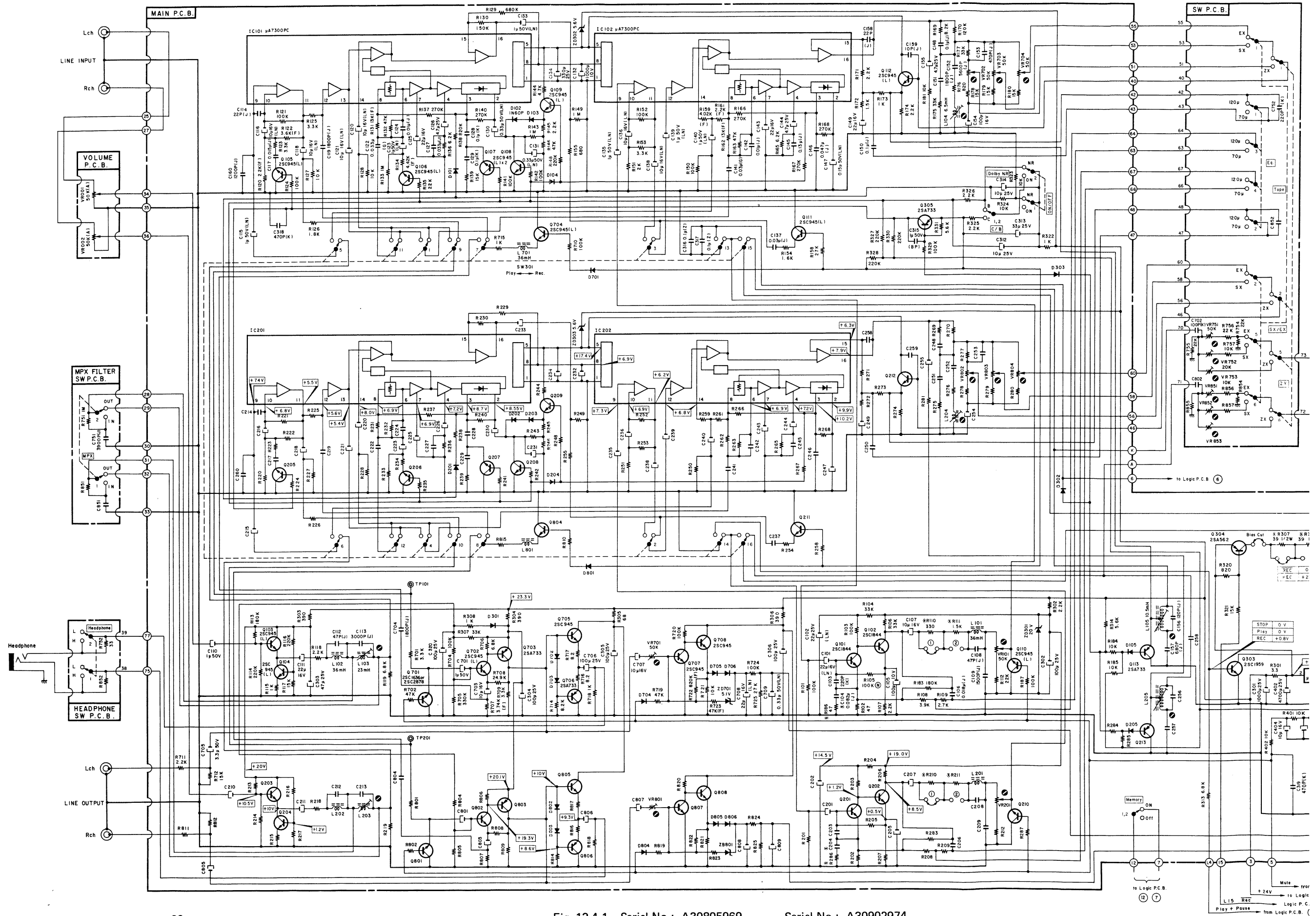
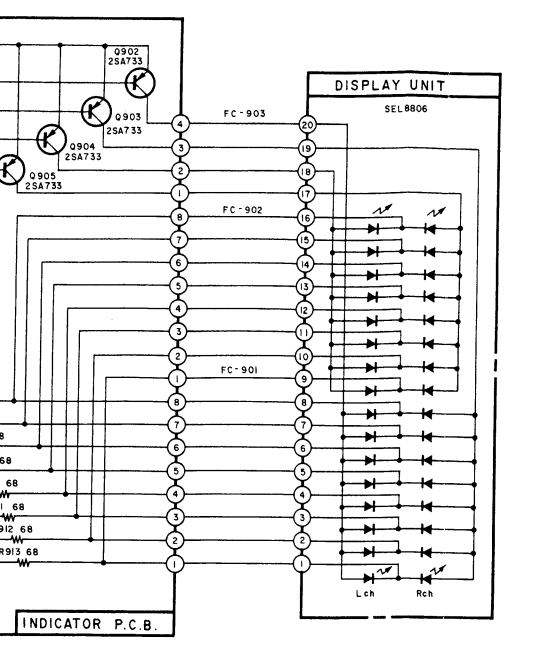
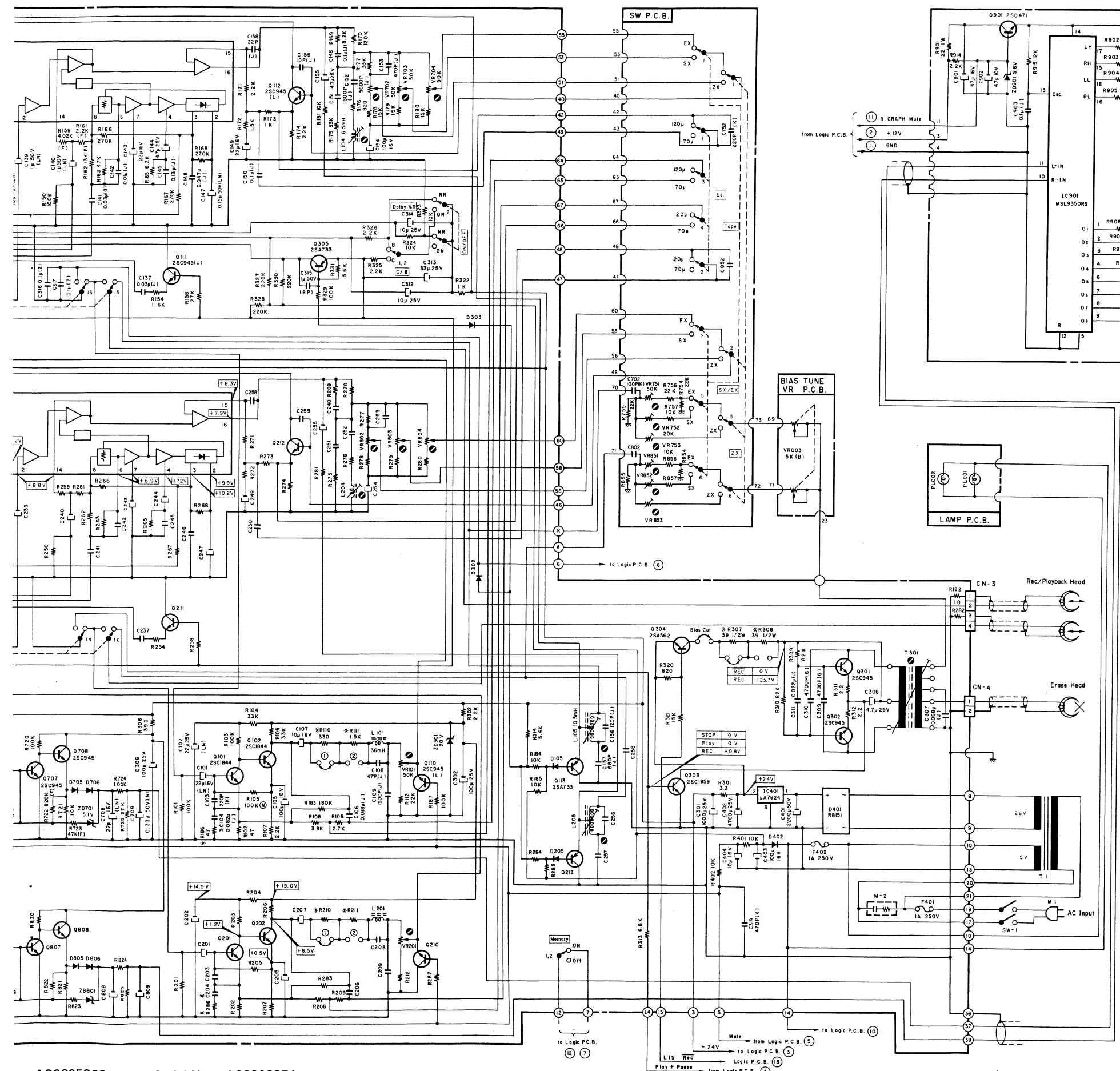
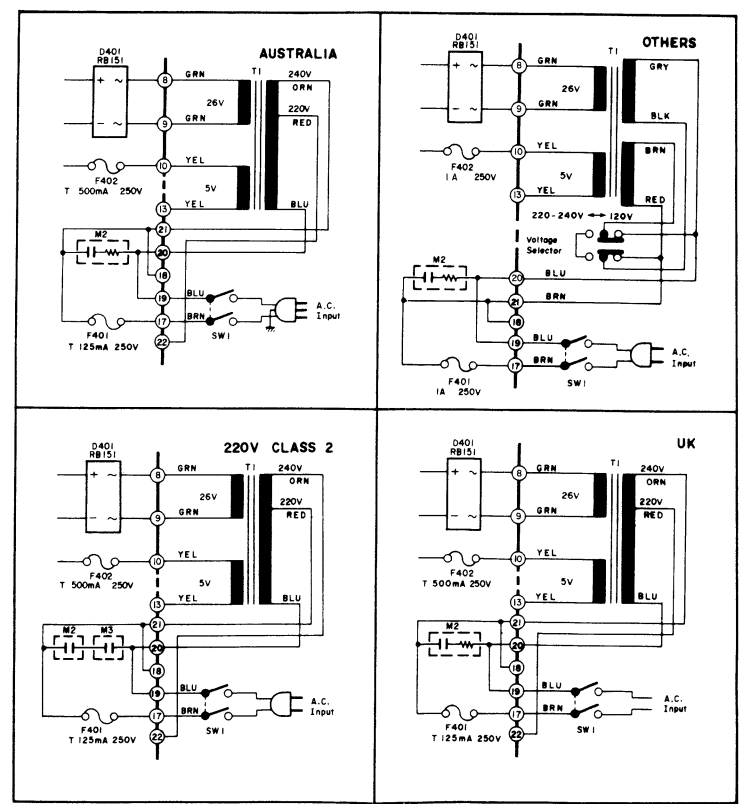

Fig. 13.4.1 Serial No.: A30805969 – Serial No.: A30902974 –



Switch Chart	
Description	Schematic Ref. Number
Record/Play	SW 301
Dolby NR ON/OFF	SW 302
Dolby NR C/B - Type	SW 303
Memory	SW 304
Eq.	SW 305
ZX	SW 306
SX/EX	SW 307
MPX	SW 308
Headphone	SW 309



Notes: 1. Diode is 1SS53, 1S953, or 1S1555 unless otherwise specified.
 2. Resistor and capacitor marked with * show typical value.

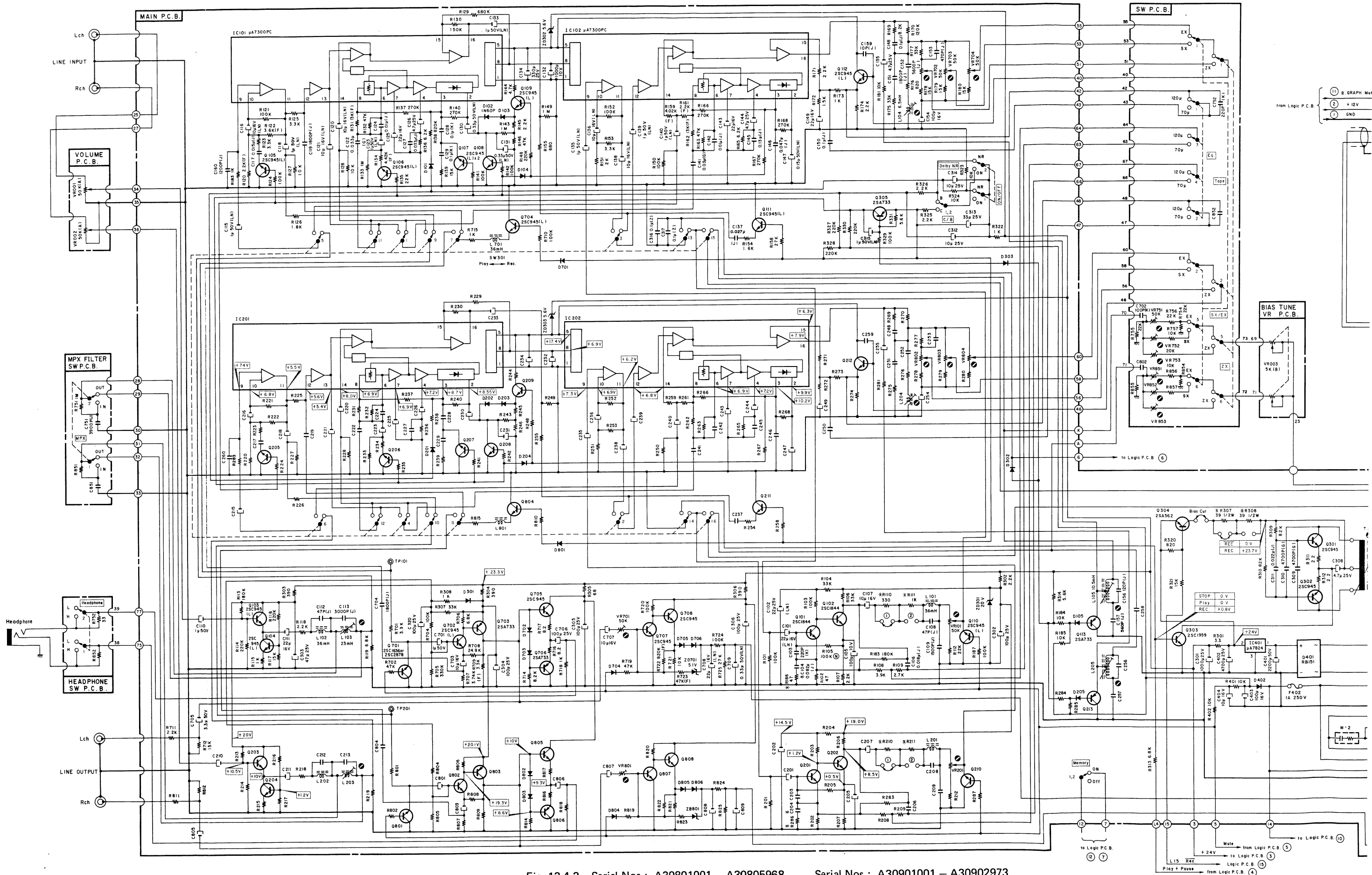
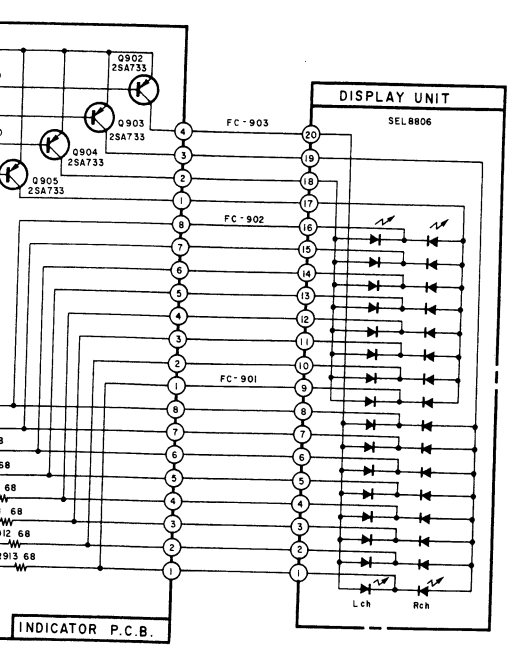
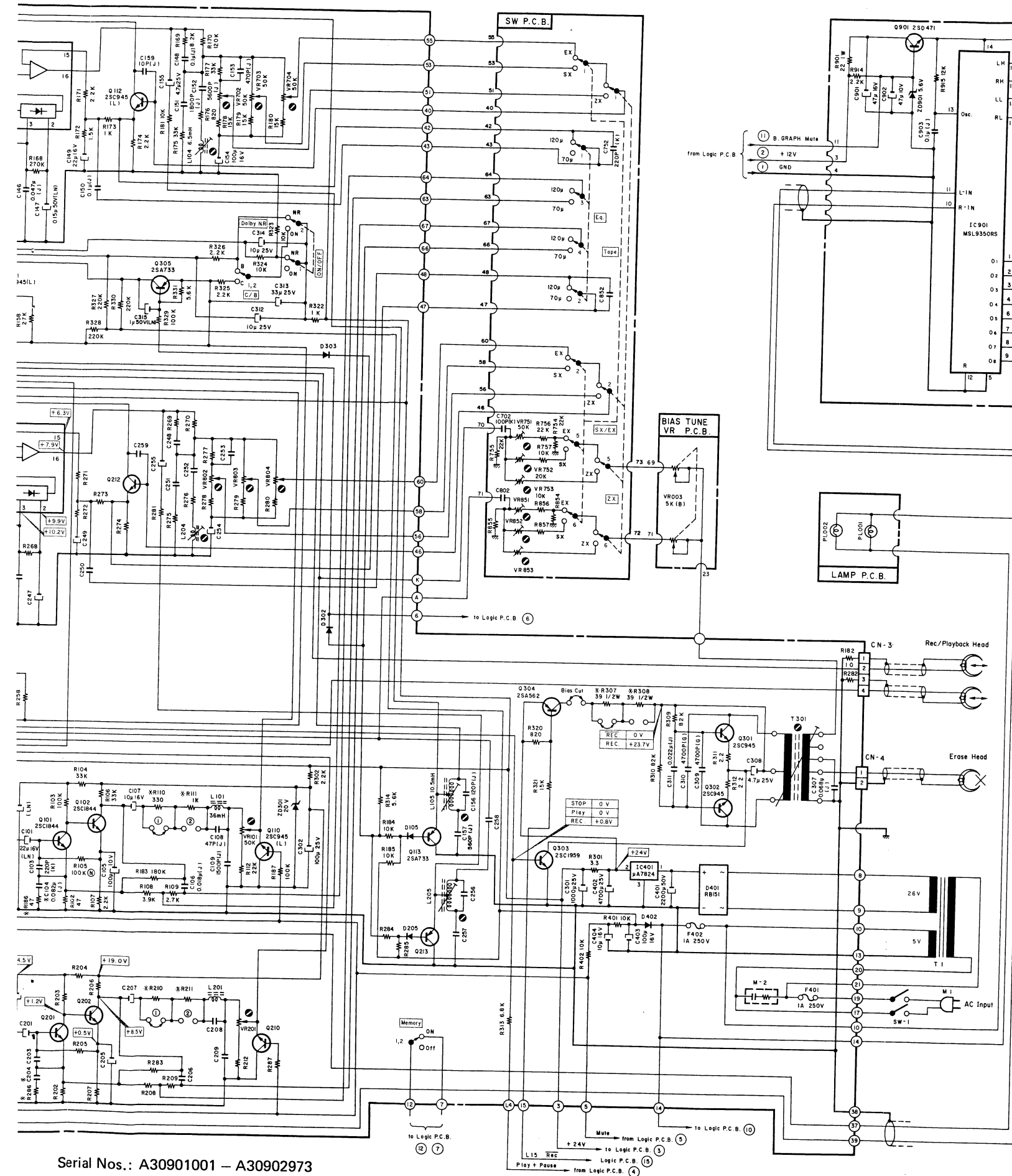
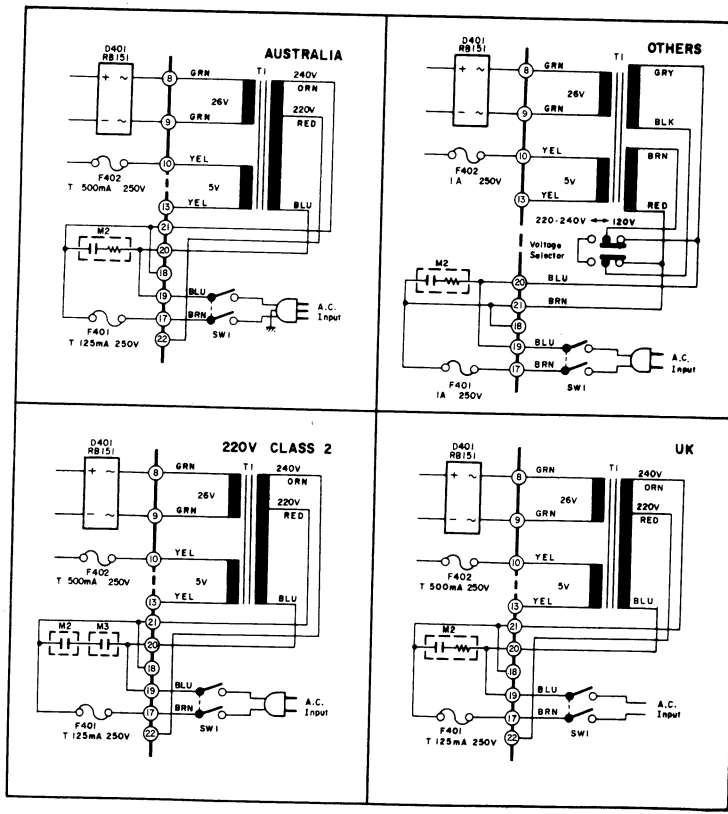

Fig. 13.4.2 Serial Nos.: A30801001 - A30805968 Serial Nos.: A30901001 - A30902973



Switch Chart	
Description	Schematic Ref. Number
Record/Play	SW301
Dolby NR ON/OFF	SW302
Dolby NR C/B - Type	SW303
Memory	SW304
Eq.	SW305
ZX	SW306
SX/EX	SW307
MPX	SW308
Headphone	SW309



Notes: 1. Diode is 1SS53, 1S953, or 1S1555 unless otherwise specified.
 2. Resistor and capacitor marked with * show typical value.

Serial Nos.: A30901001 - A30902973

14. SPECIFICATIONS

Power Source	100, 120, 120/220-240, 220 or 240 V AC; 50/60 Hz (according to country of sale)
Power Consumption	30 W max.
Tape Speed	1-7/8 ips (4.8 cm/sec) ±0.5%
Wow and Flutter	Less than 0.11% WTD Peak, 0.06% WTD rms
Frequency Response	20–20,000 Hz (–20 dB Rec. Level)
Signal to Noise Ratio	Dolby C-Type NR on <70 μs ZX Tape> Better than 68 dB at 400 Hz, 3% THD, IHF A-wtd rms Dolby B-Type NR on <70 μs ZX Tape> Better than 62 dB at 400 Hz, 3% THD, IHF A-wtd rms
Total Harmonic Distortion	Less than 1.0% at 400 Hz, 0 dB (ZX Tape) Less than 1.2% at 400 Hz, 0 dB (SX, EXII Tapes)
Erasure	Better than 60 dB below saturation level at 1 kHz
Separation	Better than 36 dB at 1 kHz, 0 dB
Crosstalk	Better than 60 dB at 1 kHz, 0 dB
Bias Frequency	105 kHz
Input	50 mV, 30 k ohms
Output Level	600 mV (400 Hz, 0 dB) 2.2 k ohms
Headphone	10 mW (400 Hz, 0 dB, phones level: High) 8 Ω
Dimensions	450 (W) x 135 (H) x 289 (D) mm 17-23/32 (W) x 5-5/16 (H) x 11-3/8 (D) inches
Approximate Weight	6.4 kg, 14 lb. 2 oz

- Specifications and appearance design are subject to change for further improvement without notice.
- Dolby NR under license from Dolby Laboratories Licensing Corporation.
- The word "DOLBY" and the Double-D-Symbol are trademarks of Dolby Laboratories Licensing Corporation.