

# Service Manual

# Nakamichi 480 2 Head Cassette Deck

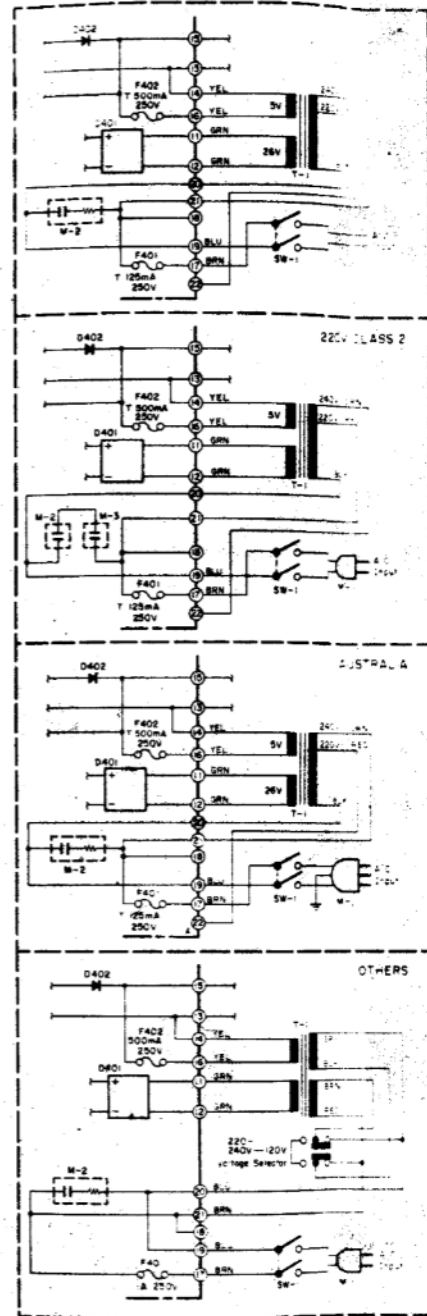

Switch Chart	
Description	Schematic Ref. Number
Record / Play	SW301
MPX	SW302
Dolby NR	SW303
ZX	SW304
SX/EX	SW305
Eq.	SW306
Memory	SW401

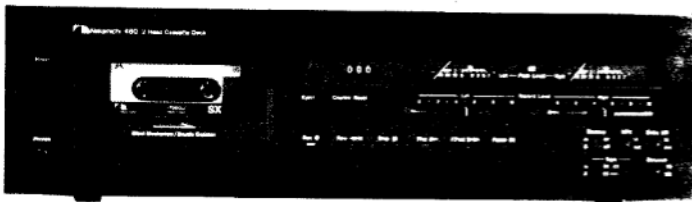

<b>General</b> .....	<b>3</b>
<b>Principle of Operation</b> .....	<b>4</b>
2. 1. Mechanisms .....	4
2.1.1. Headblock .....	4
2.1.2. Erase Head .....	5
2.1.3. Double Capstan Tape Drive .....	5
2.1.4. Mechanism Control Cam Operation .....	6
2. 2. Amp. Circuits .....	7
2.2.1. Playback Eq. Amp. Circuit .....	7
2.2.2. Record Eq. Amp. Circuit .....	9
2.2.3. Bias Osc. Circuit .....	9
2. 3. Mechanism Control Circuits .....	10
2.3.1. Outline .....	10
2.3.2. +12 V Power Source .....	11
2.3.3. Power-mute Signal .....	11
2.3.4. Auto Shut-off Circuit .....	11
2.3.5. Record Control Circuit .....	14
2.3.6. Mute Signal .....	14
2.3.7. Control Motor Drive Circuit .....	15
2.3.8. Reel Motor Governor .....	17
<b>Removal Procedures</b> .....	<b>17</b>
3. 1. Cassette Case Cover Ass'y .....	17
3. 2. Top Cover Ass'y .....	17
3. 3. Bottom Cover Ass'y .....	17
3. 4. Front Panel Ass'y .....	17
3. 5. Headphone Jack Ass'y .....	18
3. 6. Mechanism Ass'y .....	18
3. 7. Meter Ass'y .....	18
3. 8. Lamp P.C.B. R Ass'y and Lamp P.C.B. L Ass'y .....	18
3. 9. Main P.C.B. Ass'y .....	19
3. 10. Control Switch Holder Ass'y .....	19
3. 11. Switch P.C.B. Ass'y .....	19
3. 12. Volume P.C.B. Ass'y and Control Switch P.C.B. Ass'y .....	19
3. 13. Rear Panel Ass'y, Power Transformer and Power Switch .....	19
3. 14. Cassette Case Ass'y and Cover Plate Ass'y .....	20
3. 15. Tape Counter Ass'y .....	20
3. 16. Capstan Motor Ass'y and Flywheel Ass'y .....	21
3. 17. Sub Mechanism Chassis Ass'y .....	21
3. 18. Control Motor Ass'y and Reel Motor Ass'y .....	21
3. 19. Cam Control Volume .....	21
3. 20. Reel Hub Ass'y and Idler Ass'y .....	21
3. 21. Cam Drive Gear and Control Cam .....	21
3. 22. Head Mount Base Ass'y .....	21
3. 23. Pressure Roller Ass'y and Erase Head .....	22
3. 24. Record/Playback Head Ass'y .....	22
<b>Measurement Instruments</b> .....	<b>23</b>
<b>Mechanical Adjustments</b> .....	<b>24</b>
5. 1. Mechanism Control Cam Adjustment .....	24
5. 2. Tape Speed Adjustment .....	25
5. 3. Record/Playback Head Tilt Adjustment .....	25
5. 4. Head Base Stroke Adjustment .....	26
5. 5. Tape Guides Adjustment and Erase Head Stroke Adjustment .....	27
5. 6. Erase Head Height and Tilt Adjustment .....	28
5. 7. Record/Playback Head Height Adjustment and Azimuth Alignment .....	28
5. 8. Tape Travelling Adjustment .....	29
5. 9. Record Switch Linkage Adjustment .....	29

5. 10.	Flywheel Holder Adjustment	30
5. 11.	Eject Wire Adjustment	30
5. 12.	Lubrication	30
<b>6.</b>	<b>Parts Location for Electrical Adjustment</b>	<b>31</b>
<b>7.</b>	<b>Electrical Adjustments and Measurements</b>	<b>32</b>
7. 1.	Adjustment and Measurement Instructions	32
7. 2.	Playback Frequency Response Adjustment	35
7. 3.	Check on Dolby NR Circuit	35
<b>8.</b>	<b>Mounting Diagrams and Parts List</b>	<b>36</b>
8. 1.	Volume P.C.B. Ass'y	36
8. 2.	Control Switch P.C.B. Ass'y	36
8. 3.	Switch P.C.B. Ass'y	36
8. 4.	Control P.C.B. Ass'y	36
8. 5.	Auto Shut-off P.C.B. Ass'y	36
8. 6.	Lamp P.C.B. L Ass'y	36
8. 7.	Lamp P.C.B. R Ass'y	36
8. 8.	Main P.C.B. Ass'y	37
<b>9.</b>	<b>Mechanism Ass'y and Parts List</b>	<b>41</b>
9. 1.	Synthesis	41
9. 2.	Front Panel Ass'y (A01)	41
9. 3.	Synthesis Mechanism Ass'y (A02)	41
9. 4.	Meter Escutcheon Ass'y (B01)	42
9. 5.	Control Switch Holder Ass'y (B02)	43
9. 6.	Headphone Jack Ass'y (B03)	43
9. 7.	Mechanism Ass'y 480 (B04)	44
9. 8.	Chassis Ass'y (B05)	45
9. 9.	Flywheel Holder Ass'y (C01)	45
9. 10.	Sub Mechanism Chassis Ass'y (C02)	46
9. 11.	Main Mechanism Chassis Ass'y (C03)	48
9. 12.	Rear Panel Ass'y (D01)	49
9. 13.	Reel Motor Ass'y (E01)	50
9. 14.	Control Motor Ass'y (E02)	50
9. 15.	Head Mount Base Ass'y (F01)	50
9. 16.	Supply Pressure Roller Ass'y (F02)	50
9. 17.	Take-up Pressure Roller Ass'y (F03)	50
9. 18.	Head Base Ass'y C (F04)	51
9. 19.	Cassette Case Holder L Ass'y (F05)	51
9. 20.	Cassette Case Holder R Ass'y (F06)	51
9. 21.	Auto Shut-off Ass'y (F07)	51
9. 22.	Pneumatic Damper Ass'y (F08)	51
9. 23.	RP-9E Record/Playback Head Ass'y (G01)	51
<b>10.</b>	<b>Overall Timing Chart</b>	<b>53</b>
<b>11.</b>	<b>Eq. Amp. Frequency Response</b>	<b>54</b>
11. 1.	Playback Frequency Response	54
11. 2.	Record Current Frequency Response	54
<b>12.</b>	<b>Wiring Diagram</b>	<b>55</b>
<b>13.</b>	<b>Block Diagrams</b>	<b>57</b>
13. 1.	Amplifier	57
13. 2.	Mechanism Control	58
<b>14.</b>	<b>Schematic Diagrams</b>	<b>59</b>
<b>15.</b>	<b>Specifications</b>	<b>62</b>

# 1. GENERAL

## 1.1. Control Functions

Nakamichi 480 control functions are shown below:

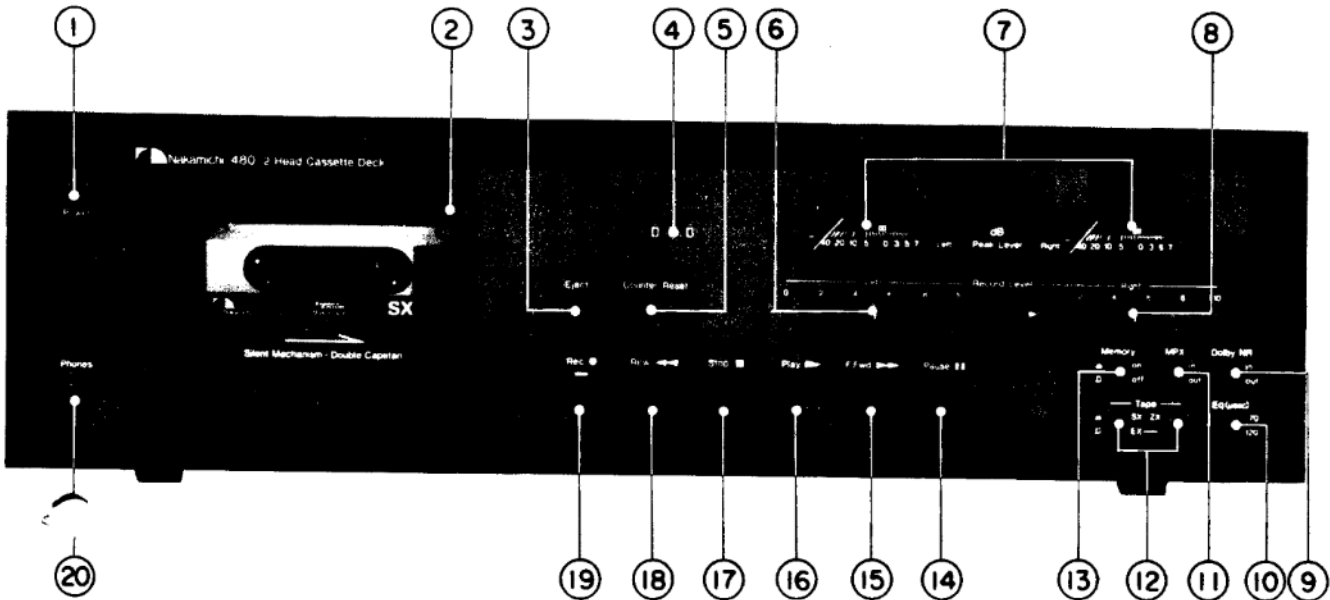

Fig. 1.1 Front View

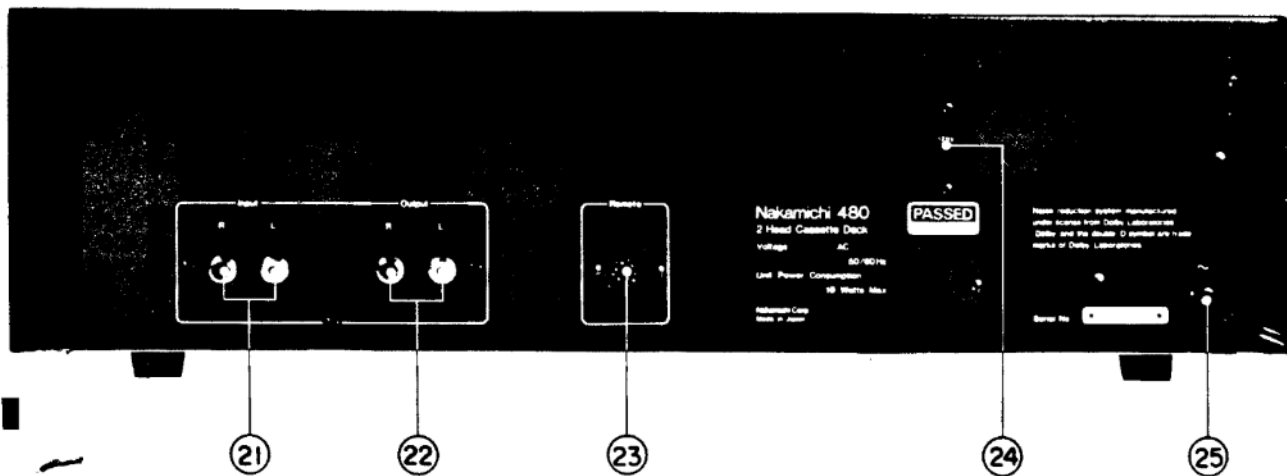

Fig. 1.2 Rear View

- |  |                             |
|--|-----------------------------|
| 1. Power Switch                        | 14. Pause Button            |
| 2. Cassette Lid                        | 15. Fast-Forward Button     |
| 3. Eject Button                        | 16. Play Button             |
| 4. Tape Counter                        | 17. Stop Button             |
| 5. Counter Reset Button                | 18. Rewind Button           |
| 6. Input Level Control - Left Channel  | 19. Record Button           |
| 7. Peak Level Meters                   | 20. Headphone Jack          |
| 8. Input Level Control - Right Channel | 21. Input Jacks             |
| 9. Dolby NR Switch                     | 22. Output Jacks            |
| 10. Eq. Switch                         | 23. Remote Control Socket   |
| 11. MPX Filter Switch                  | 24. Voltage Selector Switch |
| 12. Tape Selector Switches             | 25. Power Cord              |
| 13. Tape Memory Switch                 |                             |

## 2. Voltage Selector

A voltage selector is installed on the rear panel for other versions of the Nakamichi 480. This voltage selector can select either 120 V or 220 – 240 V at customer's disposal.

## 2. PRINCIPLE OF OPERATION

### 2.1. Mechanisms

#### 2.1.1. Headblock

Refer to Fig. 2.1.1 Headblock.

Nakamichi 480 Headblock provides more stabilized tape travel.

Accuracy of tape travel is one of the most essential factors for a device to optimize its performance. Inaccurate tape travel will therefore induce deterioration exemplified by the following:

- (a) vibration will be given to tape travel, as a result of which flutter and modulation noise will become increased
- (b) insufficient tape-to-head contact will result in level drops
- (c) tape skew will become greater and frequency response will become decreased

Needless to say, constant tape travel must consist of smooth drive mechanism, as well as of the fact that tape, heads and tape guide are placed in the most appropriate positions.

N-480 Record/Playback Head is made small in size. Erase Head is located at the place where the Record Head is located in the N-70011/100011.

Record/Playback Head is assembled on the Head Mount Base. Take-up Tape Guide and Supply Tape Guide are fixed to the Take-up and Supply Pressure Rollers respectively. Erase Head is placed on the Head Base. All these can be separately adjusted. Shape of the Heads and its location have been carefully studied to bring about smoother contact of tape with the Heads. Pad Lifter is affixed to the Record/Playback Head so as not to let Tape Pad touch the Head to give more stabilized tape travel, making it free from the influence of the Tape Pad within the Cassette Tape. Thus the trouble of changes in azimuth can now be avoided at changing of cassette tape, if only the Record Head azimuth is properly adjusted in advance.

#### (1) Adjustment of Tape Guide Height

Tape Guides for the N-480 are affixed to the Supply Pressure Roller Ass'y and Take-up Pressure Roller Ass'y. With springs in the studs of Main Mechanism Chassis Ass'y, the Supply Pressure Roller Ass'y and Take-up Pressure Roller Ass'y are tightly affixed with Tape Guide Adjustment Nuts. The Adjustment Nuts are placed on the springs, and therefore either by tightening or loosening, height adjustment of the Tape Guides will become possible.

#### (2) Record/Playback Head Height Adjustment and Azimuth Alignment

Azimuth and height of Record/Playback Head are independent from each other and adjustment may be done separately without affecting others. In order to adjust the tilt of Record/Playback Head backwards or frontwards, take off the Height Gear Stopper and take out the Height Gear and then turn the two Height Adjustment Screws. After completion of adjustment, place the Height Gear back and fix it with the Height Gear Stopper. After the tilt is adjusted in such a way as above, adjust the height by turning the Height Gear. Azimuth is aligned by turning the Azimuth Alignment Screw. This system has been carefully designed so as to minimize influence each other between azimuth alignment and height adjustment.

#### (3) Erase Head Height and Tilt Adjustment

Erase Head is affixed onto the Erase Head Plate which is assembled with the Head Base. It is installed with three screws. By turning these screws, its height, tilt of backward or forward, and tilt of leftward or rightward can be adjusted separately, thus the best location of Erase Head can be obtained.

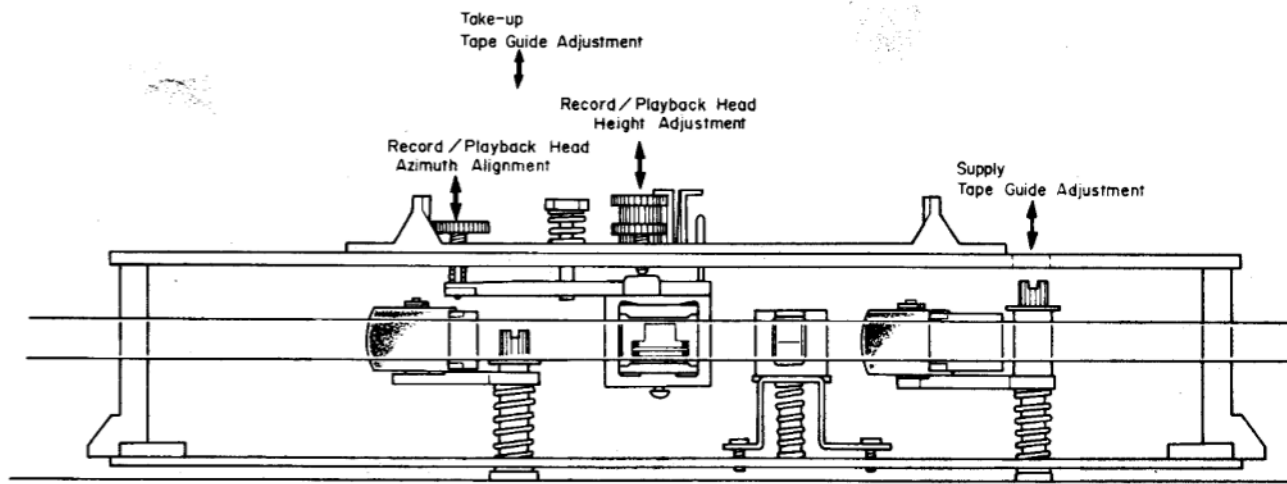

Fig. 2.1.1 Headblock

## 1.2. Erase Head

Fig. 2.1.2 shows the sectional view of the Erase Head. Fig. 2.1.3 shows the characteristics of erasing current and erasure.

It has the same characteristics with the previous type Direct-Flux Erase Head but has been purposely developed to minimize the size further.

The conventional Erase Head had its inside core narrower than its outside core, while this Erase Head is equipped with an inside core wider than the outside core. This has resulted in more power sufficient enough for erasing with smaller power consumption, approx. 0.5 W, though the head width is as small as 3 mm. The smaller the power consumption is, the smaller will be the heat generation, and this is of course another merit.

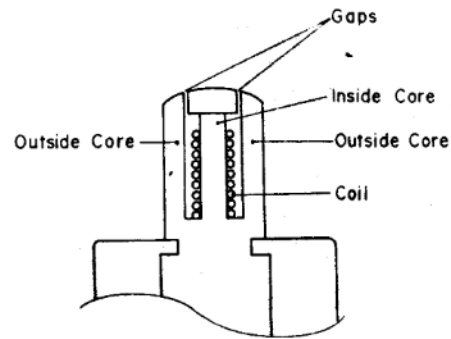

Fig. 2.1.2 Sectional View of Erase Head

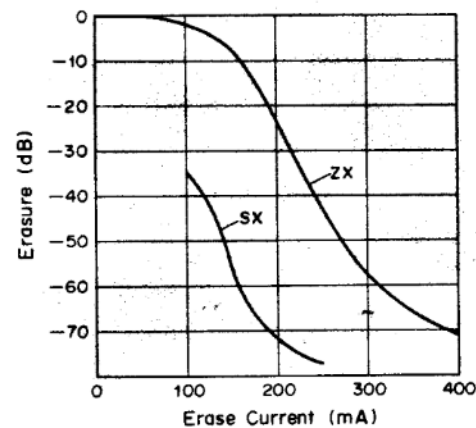

Fig. 2.1.3 Characteristics of Erasing Current and Erasure

### 2.1.3. Double Capstan Tape Drive

As shown in Fig. 2.1.4, the double capstan system consists of two capstan shafts (a) and (b) connected to the two flywheels which are driven by a capstan belt.

Against these capstans two pressure rollers (a) and (b) are engaged to run the tape with an adequate holdback tension created by the double capstan and pressure rollers. Since the diameter of capstan shaft (a) is smaller than that of capstan shaft (b), when two flywheels begin to turn as shown in the figure, capstan (a) runs slightly faster than capstan (b), which subsequently generates holdback tension.

As you note, if the diameters of the 2 capstans should be the same, the generation cycles of wow and flutter will become approximately the same, as a result of which defective portion will be doubly superposed and preferable portion vice versa. The N-480 employs 2 capstans, each having different diameter and rotations, thereby avoiding the aforesaid occurrence and stabilizing wow and flutter characteristics.

As the double capstan system always creates a constant and stable holdback tension between the two capstans, the condition of the tape between two capstans will not be affected by any external conditions such as irregular take-up and supply torques, irregular loading of cassette tape, undesirable mechanism vibration and etc., thus assuring the superior wow and flutter characteristics. The double capstan system provides a constant holdback tension on the tape and maintains the stable pressure onto the tape against the heads.

The only critical factor in the double capstan system is to be considered; the two capstans have to be positioned perfectly in parallel and to be precisely vertical against the head base, the pressure rollers have to be evenly pressed against the capstan shafts and the head surface must be positioned perfectly vertical to the tape surface. Otherwise, the running tape might become out of the tape guide resulting in irregular movement.

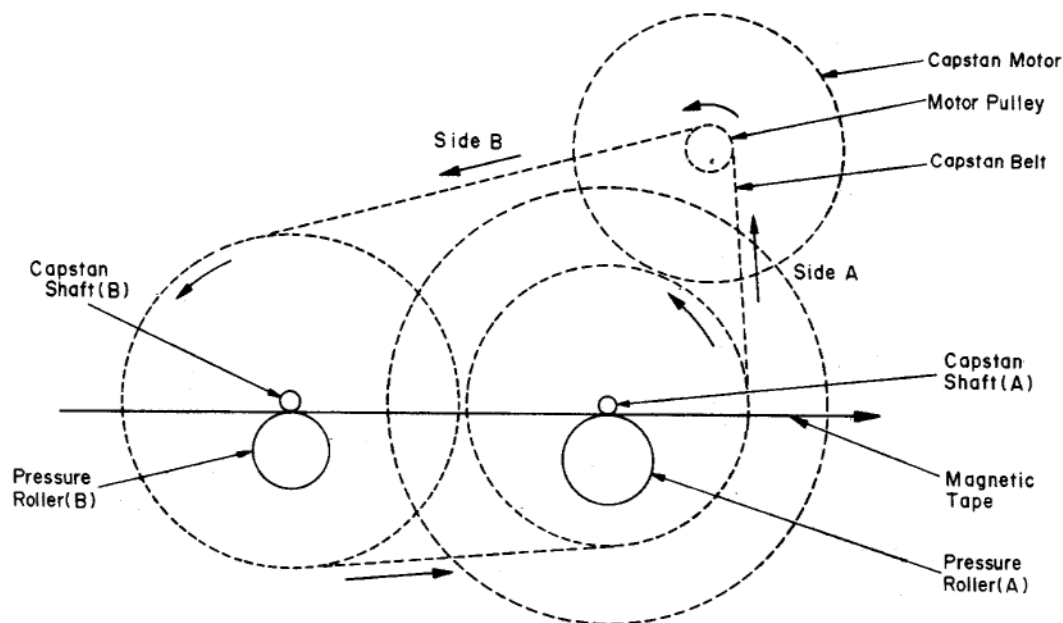

Fig. 2.1.4 Double Capstan Tape Drive

#### 2.1.4. Mechanism Control Cam Operation

Refer to Fig. 2.1.5 Mechanism Control Cam timing chart. Function of N-480 Mechanism is done by Cam Control. Cam is driven by the Control Motor. The Motor operates so as to result zero in the difference of voltages between each voltage corresponding to mechanism function and each reference voltage which corresponds to each commands of the Control Switch. When the difference comes to zero, then it stops. In this way, each function is kept properly operated. For further details, please see the explanation on Logic Control. Here we explain principle of its mechanical functions.

Cam Control System works as follows: Cam Drive Gear is driven by Control Motor by means of Drive Belt. Cam Drive Gear is related to the cam with which each function may be mechanically set on.

##### (1) Play Mode

Press the Play Switch to make it Play mode. Then the Cam begins to move from Stop position to Play position and the Play mode will be set.

The Head Base which is linked to the Cam and which is normally pushed against the Stop position gets released and the Head Base will slowly come out for playing. To explain this function, first the Head Base is latched and the Reel Motor begins to turn. Then the Pressure Roller will be pushed and the Brake will be released. Now the tape begins to run. If you press the Pause Switch at this stage, it comes to Pause mode. Brake operates and the Pressure Roller moves away from the Capstan and the Reel Motor stops.

Play mode may be changed to Stop mode by pressing the Stop Switch, and latch of the Head Base being released. The Cassette Case cannot be opened because of the latched eject effect unless it is in Stop mode.

##### (2) Record Mode

By pressing the Record Switch and the Pause or Play Switch, it may be made to Record mode. The Cam at this moment moves from Stop position to Rec. position. At the same time, Rec. Trigger Mechanism is driven and the Record Switch on the Main P.C.B. is switched on to the Record side. Further, the Cam turns until it comes to the Pause or Play position. On the other hand, the Rec. Trigger Mechanism is released during this process. When the Cam is set in Rec./Pause or Rec./Play position, Record signals will be sent to Bias Oscillating Circuit from Logic Control Circuit to let the Bias to oscillate. Press the Stop Switch and the Cam comes back to the Stop position. At the same time, it will set the Record Switch on the Main P.C.B. to the Play side.

##### (3) F.F. or Rewind Mode

By pressing the F.F. or Rewind Switch, it comes either to F.F. or Rewind mode. The only difference of these two modes is that one is to turn the Reel Motor reverse and the other to transmit the torque against the Reel Hub onto the take-up side or to the supply side. Brake is released at this stage and the Reel Motor begins to turn F.F. or Rewind.

#### (4) Pause Mode

Press the Pause Switch to make it to Pause mode. In changing it from Stop mode to Pause mode, the Brake is first released, then the Head Base is latched, and again the Brake works.

At this stage, the Reel Motor would not turn with the Pressure Roller being apart from the Capstan, and the tape would remain still.

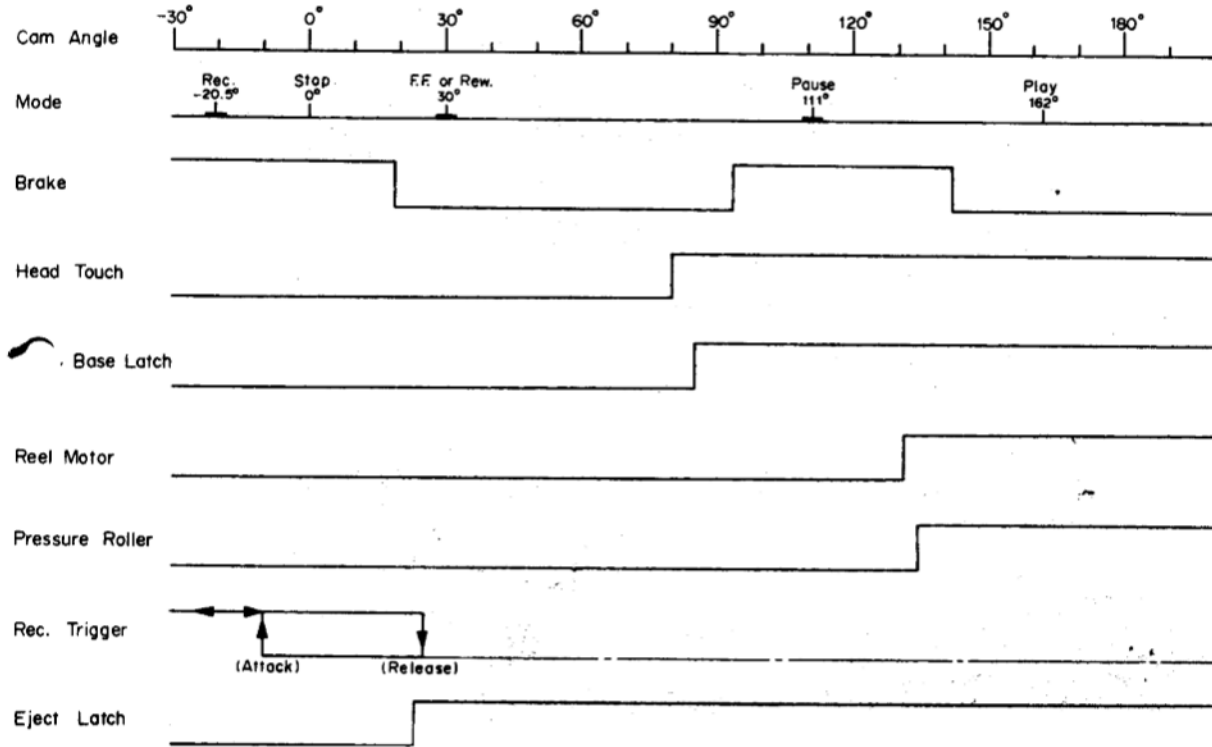

Fig. 2.1.5 Mechanism Control Cam Timing Chart

#### 2. Amp. Circuits

##### 2.1. Playback Eq. Amp. Circuit

2.2.1 shows the playback equalizer circuit, and Fig. 2.2 shows the system diagram.

2.2.3 shows the time constant of equalizer. The playback head is connected with circuit's input.

Amplifier (Q101 and Q102) is an equalizer amplifier its time constant is illustrated in Fig. 2.2.3. R111, R112, L101, and C109 compose a peaking circuit. This circuit compensates the gap loss of the playback head so that high-frequency response will be improved.

Playback Eq. Amp. gain is adjusted by semi-fixed volume potentiometer (VR201) to obtain 100 mV output level at TP101 (TP101) when 400 Hz Level Tape (DA09005A) is being played back. Equalizer Switch (70 μs/120 μs) is connected to the Playback Eq. Amp. The overall time constants in Playback Eq. Amp. are as follows:

Eq. SW – 70 μs

3180 μs (50 Hz) + 70 μs (2274 Hz)

Eq. SW – 120 μs

3180 μs (50 Hz) + 120 μs (1326 Hz)

Shown below is the table for the position of Tape Switch and Eq. Switch:

Tape SW	Eq. SW	Tape
ZX	70 μs	Nakamichi ZX
SX	70 μs	Nakamichi SX, TDK SA, Maxell XL-II, Scotch Master 70 μs
EX	120 μs	Low-Noise High-Density (including EX, EXII, TDK AD, Maxell XL-I, Scotch Master 120 μs)
	70 μs	Nakamichi EX, EXII



It is specified in the IEC Standard that the time constant is 120  $\mu$ s on tapes of ferric oxide, and 70  $\mu$ s on tapes of CrO<sub>2</sub>.

However, in the case of Eq. Switch on the N-480, when time constant at playback is changed, at the same time time constant at record must also be changed.

Therefore, even though record and playback is made by the method other than the IEC Standard, no deterioration

of frequency response or level difference will occur. (Any other method for instance, record and playback on ferric oxide tape with putting Tape Switch on EX and Eq. Switch on at 70  $\mu$ s.)

When Nakamichi EX or EXII Tape is used at Tape Switch: EX, and Eq. Switch: 70  $\mu$ s, S/N ratio will be improved by approximately 4 dB (WTD).

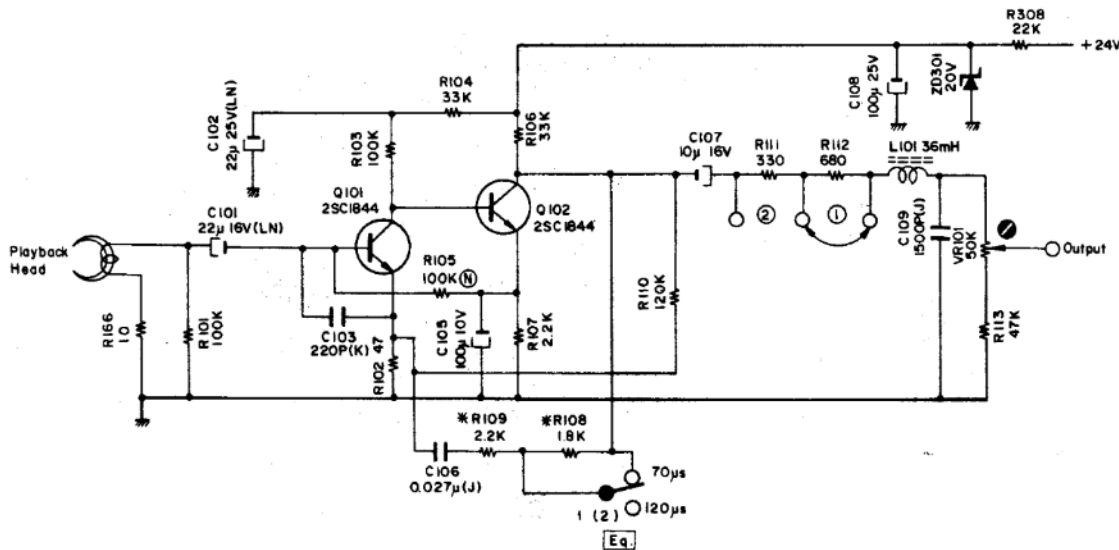

Fig. 2.2.1 Playback Eq. Circuit

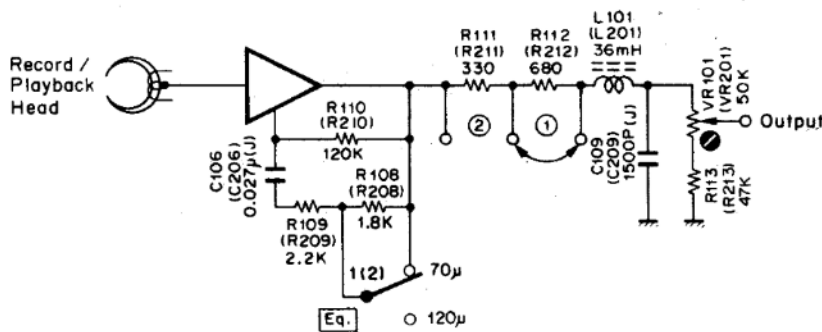

Fig. 2.2.2 System Diagram

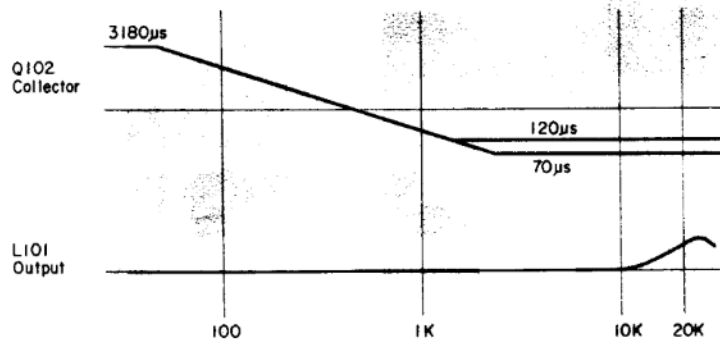

Fig. 2.2.3 Time Constant

### 2.2.2. Record Equalizer Amplifier Circuit

The record equalizer amplifier circuit consists of the Output Amp. incorporated in the Dolby NR IC and peripheral circuits as shown in Fig. 2.2.4.

VR102, VR103, and VR104 are the record calibration semi-fixed volumes for ZX, SX, and EX tapes. The output of the Output Amp. is given to these volumes, and the outputs from the volumes are fed back to the inverting input of the Output Amp. via amplifier Q103 and a time-constant changeover circuit.

By adjusting L104, compensation for the high frequency range is made by setting a resonance frequency at 21 kHz or neighborhood.

L105, C138 and C139 compose a recording bias trap circuit.

### 2.2.3. Bias Osc. Circuit

Fig. 2.2.5 shows a push-pull oscillator with an oscillation frequency of 105 kHz which is constructed by capacitors C302 and C303 coupling the collectors and bases of two transistors (Q301 and Q302).

This is used to provide recording bias and as an erase signal.

By pressing the Record and Pause, or Record and Play buttons, (Play + Pause)-Position signal conducted from the logic control circuit becomes H and Q303 turns to ON.

Therefore, +24 V is applied to the circuit and oscillation begins.

When the record mode is released, oscillator output is damped by the discharge of C304. This prevents magnetization of the head.

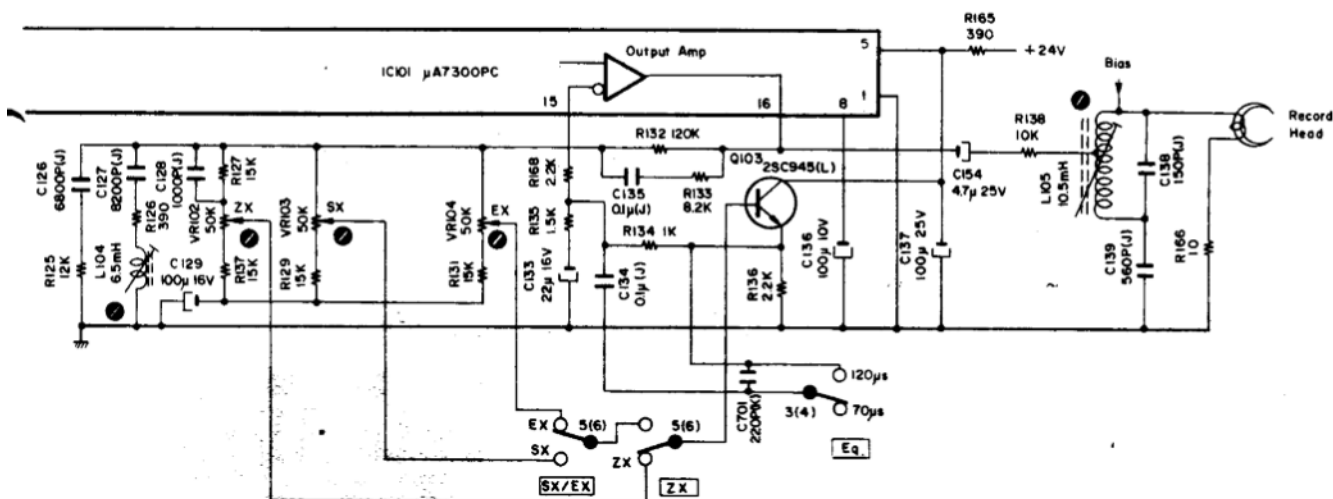

Fig. 2.2.4 Record Eq. Amp. Circuit

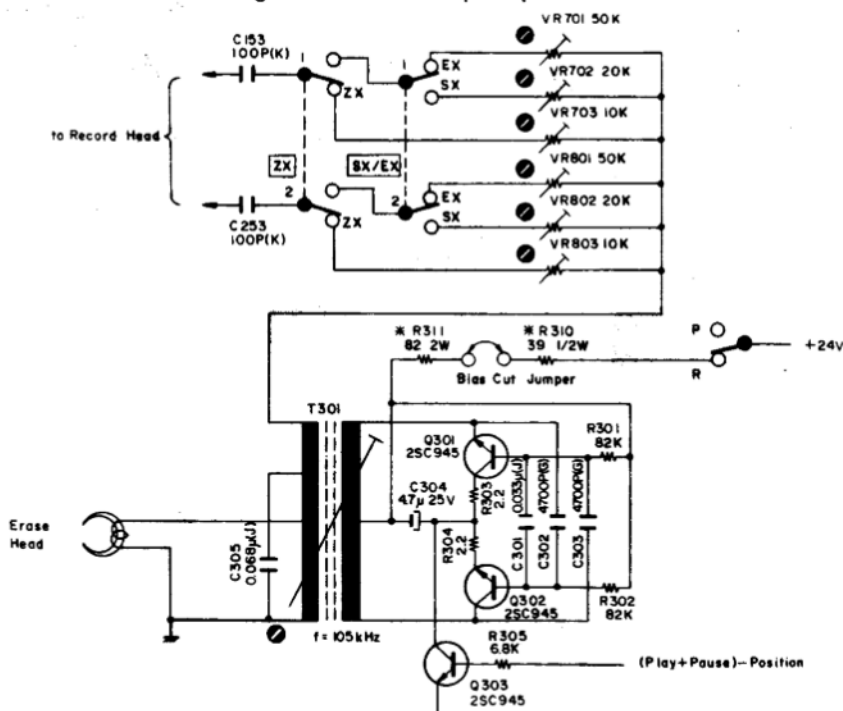

Fig. 2.2.5 Bias Osc. Circuit

## 2.3. Mechanism Control Circuits

### 2.3.1. Outline

#### (1) Control Button Operation

Record, Rewind, Stop, Play, and Fast-Forward Buttons consist of a 5-way switch and are interlocked each other. When one button is pressed, it is mechanically locked in the ON state and other buttons are mechanically released. Stop Button is of momentary type and acts to release other buttons mechanically. But it is not used to control circuits electrically. Pause Button is independent from others and is of push-on and push-off type. Note that if two or more buttons are pressed simultaneously, these buttons are locked in the ON state. Under the normal control button operation, only Record and Play Buttons are pressed simultaneously to set the N-480 in RECORD mode. In this case, both Record and Play Buttons are locked in the ON state and RECORD mode is set. The N-480 is designed so as not to occur erroneous operation even if two or more buttons are pressed simultaneously. Further, to prevent from abnormal tape tension, loosening of tape, etc., the N-480 changes its mode by passing through momentary STOP mode automatically, for example, when PLAYBACK mode is commanded while FF mode, or REW mode is commanded while FF mode.

#### (2) Auto Shut-off Function

Refer to Fig. 2.3.1 basic circuit diagram.

During FF, REW, or PLAY (PLAYBACK or RECORD)

mode, auto shut-off will be activated when the tape comes to end, and FF, REW, or PLAY mode is changed to STOP mode.

Following explanation is made in regard to REW mode:

In the initial condition, Q428 is turned ON and +24 VS is applied to the emitter of Q402. When Rewind Button is pressed, it is locked in the ON state, as a result, Q402 is turned ON, the REW signal becomes H, and the N-480 is set in REW mode.

When tape-end comes, auto shut-off is activated and Q428 is turned OFF, as a result, +24 VS is shut-off, Q402 is cut off, and the REW signal becomes L. In this way, REW mode is changed to STOP mode. (Note that Rewind Button is still locked in the ON state.) When Play Button is pressed in this state, REW Button is released and Q428 is turned ON, as a result, +24 VS is applied again, Q418 is turned ON, the PLAY signal becomes H, and the N-480 is set in PLAY mode.

#### (3) Unattended Recording or Playback

Unattended recording or playback is carried out by the use of the lock mechanism of control button, therefore, no special circuit is required for this purpose.

If Record and Play Buttons are pressed, unattended recording can be carried out when the power is connected to the N-480. If only Play Button is pressed, playback will be carried out when the power is connected to the N-480.

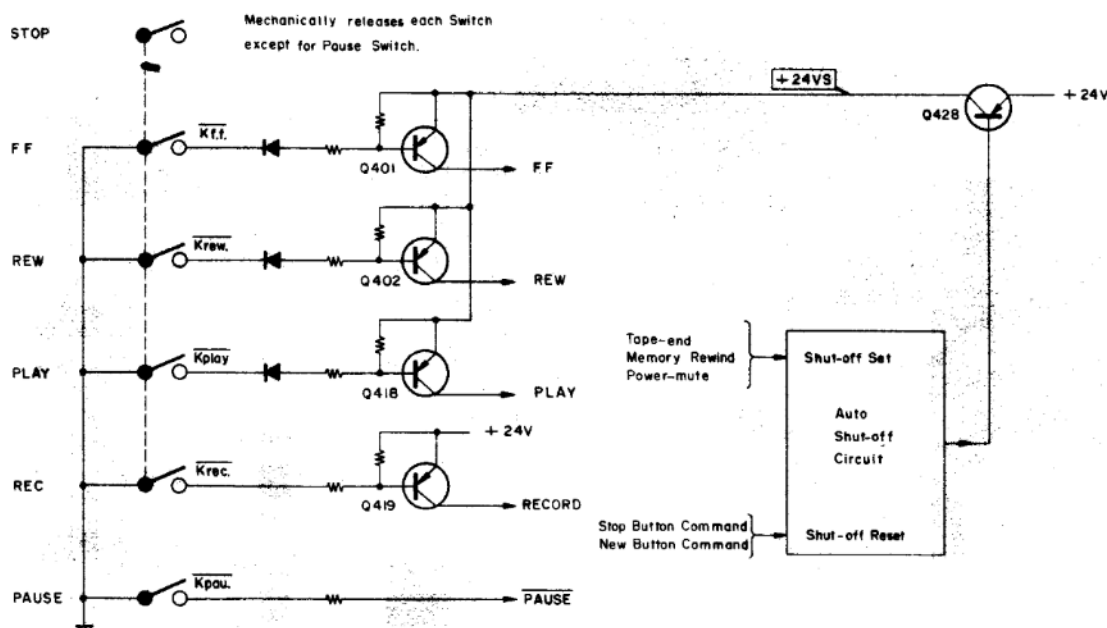

Fig. 2.3.1 Basic Auto Shut-off Circuit

### 3.2. +12 V Power Source

Refer to Fig. 2.3.2 circuit diagram. Only +24 V DC power supply is used in the N-480. The circuit acts to produce a +12 V power source from the +24 V DC power supply. The mechanism control is done by using this produced +12 V.

### 3.3. Power-mute Signal

Refer to Fig. 2.3.3 circuit diagram and Fig. 2.3.4 timing chart. Power-mute = L signal is produced pulse-like when Power Switch is turned ON or OFF. This L pulse mutes the amp. circuit and also acts to shut off the shut-off circuit initially.

#### (1) Power Switch ON

Q433 is turned ON at every positive half cycle of the output from the secondary winding of the power transformer. When Q433 is turned ON, C416 is discharged, as a result, the voltage of C416 can not exceed the VBE of Q432, and Q432 is in the cutoff state.

Therefore, the Power-mute = L pulse is produced for a certain period of time when +24 V is built up after Power Switch is turned ON.

The Power-mute = L signal makes Q416 to turn ON, as a result, Mute signal becomes H and the amp. circuit is muted.

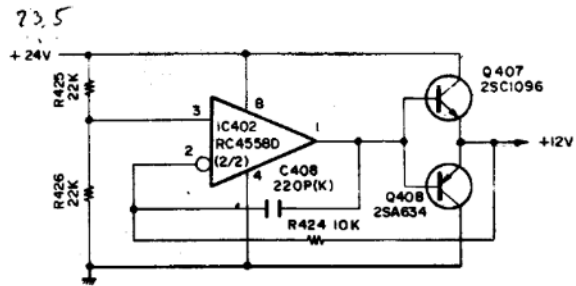

Fig. 2.3.2 +12 V Power Source Circuit

Meanwhile, the Power-mute = L pulse is applied to the shut-off circuit and shut-off is activated.

#### (2) Power Switch OFF

The output from the secondary winding of the power transformer ceases quickly, and Q433 is turned OFF. Consequently, the base current flows to Q432 through R481, Q432 is turned ON, and the Power-mute signal becomes L.

The Power-mute = L signal makes Q416 to turn ON, as a result, Mute signal becomes H and the amp. circuit is muted. At the same time, shut-off circuit is shut off by the Power-mute = L signal.

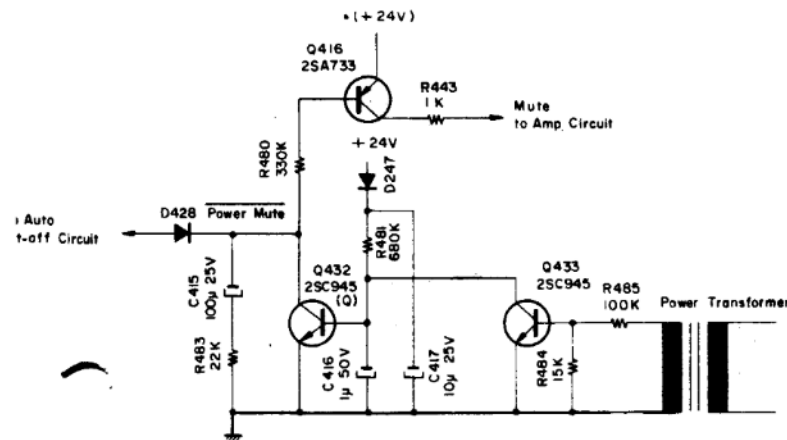

Fig. 2.3.3 Power-mute Circuit

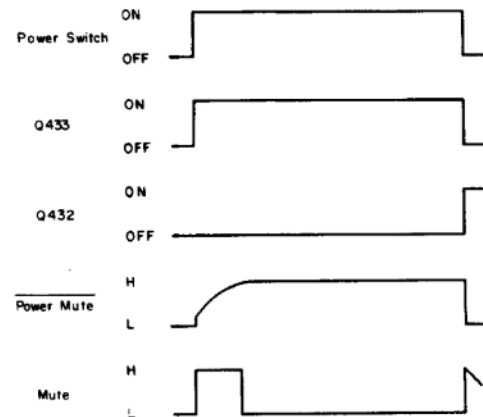

Fig. 2.3.4 Timing Chart

### 3.4. Auto Shut-off Circuit

Refer to Fig. 2.3.5 circuit diagram and Fig. 2.3.6 timing chart.

#### (1) Shut-off Sensor

Light from lamp PL407 is projected through holes in a disc rotating synchronously with the take-up reel, and the intermittent flashes coming through the disc are converted to electrical signals by a phototransistor Q450. These signals are amplified into square waves, and transmitted to the shut-off detecting circuit in the subsequent stage. When the tape-end comes, the take-up reel and the disc stop rotating, and no pulse is output from the sensor.

#### (2) Shut-off Detecting Circuit and Peripheral Circuits

Shut-off conditions are as follows:

- reached tape-end during PLAY (PLAYBACK or RECORD), FF, or REW mode
- mode is changed as follows:
  - from FF to REW mode, or vice versa
  - from FF to PLAY mode
  - from RECORD mode to FF or REW mode

When the mode is changed, shut-off is momentarily activated and the mode is changed to STOP mode in a short period of time, and after this STOP mode is over, a new mode is set.

- Power-mute = L pulse is generated when Power Switch is turned ON or OFF
- memory rewind function is activated.

(a) Reached tape-end during PLAY (PLAYBACK or RECORD), FF, or REW mode

Explanation is made for PLAY mode as an example. For FF or REW mode, the shut-off function is the same as for PLAY mode.

As Play Button is locked ON mechanically,  $K_{play} = L$ . Accordingly, R488 (100 k $\Omega$ ) is grounded through Play Button and the voltage at the point A becomes approx. +23 V. Since the voltage at the point A is not lower than the emitter voltage of Q424, Q424 is turned OFF and Q426 is also turned OFF. (Q424 and Q426 will be turned ON when the voltage at the point A is further lowered as described in subsequent (b).)

Q425, Q427, Q430, R470 and C412 consist of a shut-off detecting circuit. During PLAY mode, the voltage at the point A is approx. +23 V, therefore, Q425 is turned ON and C412 (2.2  $\mu$ F) is charged toward +24 V through R470.

Meanwhile, pulses from the shut-off sensor are applied to the base of Q427 through R489 and C418, and, at every H cycle of the sensor output pulse, Q427 is turned ON and C412 is discharged through Q427. When the tape-end is detected, pulses from the shut-off sensor are not transmitted and Q427 is turned OFF, resulting in C412 being charged continuously.

When the voltage of C412 exceeds the sum of the emitter voltage (approx. 5.5 V) and the VBE of Q430, Q430 is turned ON and the base current flows to Q429. Consequently, Q429 is turned ON, Q428 is cut off, +24 VS is shut-off, PLAY mode is changed to STOP mode, and play lamp goes out.

Q430, Q429, Q428, R476, R474, R456 and C420 consist of a Schmitt circuit which provides hysteresis characteristics for ON/OFF of Q430. Accordingly, Q430 will be

turned ON or OFF without chattering for the input waveform with a large time constant developed across C412. If Pause Button is pressed during PLAY mode, tape stops and no pulse is transmitted from the shut-off sensor, but Q427 is kept ON since Q423 is turned ON during PLAY-PAUSE mode, therefore, no charge is made at C412 and shut-off is not activated.

When shut-off is made at the tape-end during PLAY mode, PLAY mode is changed to STOP mode.

If Stop Button is further pressed, Play Button will be released and the voltage at the point A returns to +24 V as R488 is released from grounding, as a result, Q425 is turned OFF and C412 is discharged quickly through D423 and R467 (10 k $\Omega$ ). Accordingly, Q430 is turned OFF, Q429 is turned OFF, Q428 is turned ON, and +24 VS is again applied preparing for the next control button operation.

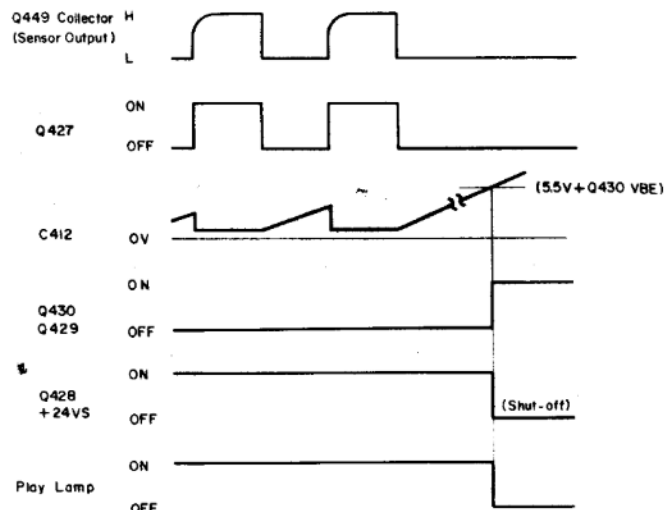

Fig. 2.3.6 Timing Chart

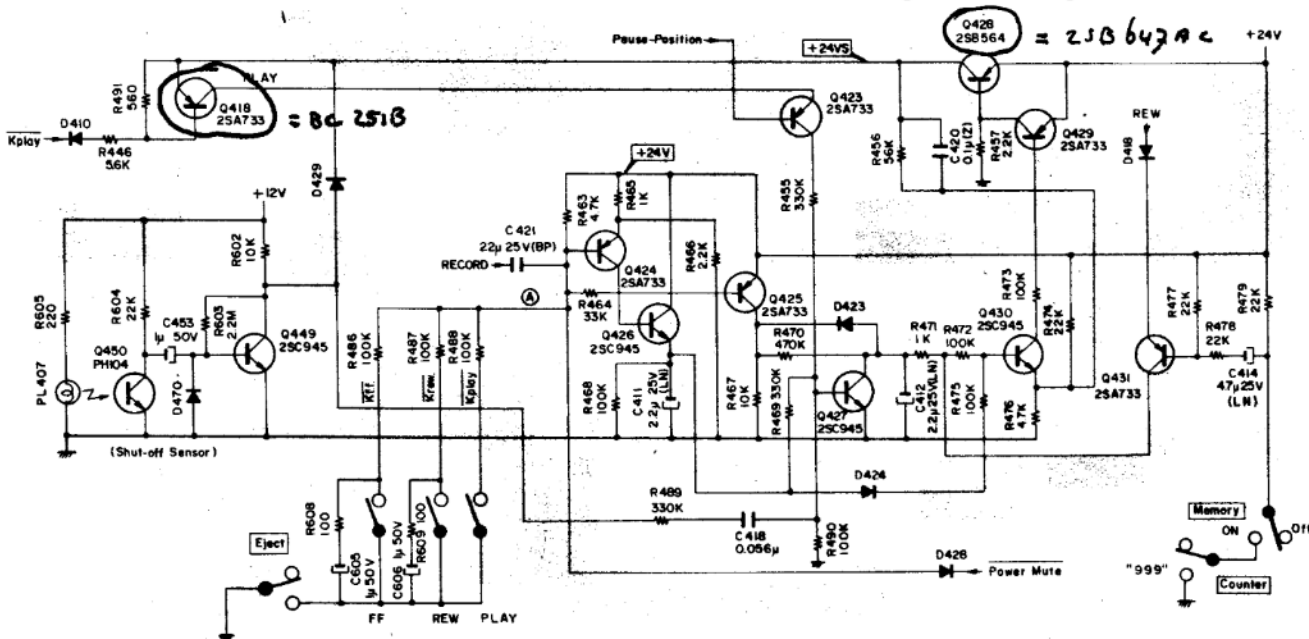

Fig. 2.3.5 Auto Shut-off Circuit

mode is changed

from FF to REW mode, or vice versa, or from FF to PLAY mode

to Fig. 2.3.7 timing chart.

mode is changed from FF to REW mode, or vice versa or from FF to PLAY mode, momentary STOP is automatically taken in view of the response of the deck mechanism, and after this is over, a new mode is

Following explains in regard to the case when FF is changed to PLAY mode by pressing Play Button in FF mode:

In FF mode, R486 (100 kΩ) is grounded by the  $\overline{Kf.f.}$  signal. When Play Button is pressed, it is locked ON. When FF Button is released, although FF Button is released, the  $\overline{Kf.f.}$  signal is kept L for a short period of time by the delay circuit (C605 and R608) connected in parallel to the button acts to prolong the  $\overline{Kf.f.} = L$  signal. During this period, the voltage at the point A becomes approx. 12 V from +23 V pulse-likely as R486 and R488 are pulled down by the  $\overline{Kf.f.} = L$  and  $\overline{Kplay} = L$  signals respectively. Consequently, Q424 and Q426 are turned ON, C411 is charged up to +24 V, but C411 will be discharged after this period is over. The base current to Q424 is supplied from C411 through D424 and R475, as a result, Q430 and Q429 are turned ON, Q428 is turned OFF and +24 VS is shut off resulting in STOP mode. On the other hand, since the base current to Q427 is supplied from C411 through R469, R427 is turned ON after the discharge of C411 is completed. When the collector voltage of C411 is lowered than the emitter voltage (approx. 4.2 V) of Q430, Q430 and Q429 are cut off, Q428 is turned ON, and +24 VS is supplied, as a result, the PLAY becomes H (+24 VS) and PLAY mode is set.

#### From RECORD mode to FF or REW mode

mode is changed from RECORD to FF or REW mode, momentary STOP mode is automatically taken in view of the tape deck mechanism, and after this is over, the new mode is set.

Record Button is released by pressing either FF or REW Button, Q419 is turned from ON to OFF, therefore, a negative differentiated pulse is applied to the point A (22 μF).

This negative pulse acts to turn ON Q424 and Q426, as a result, C411 is charged up to +24 V. FF or REW mode is set after passing through a certain period of STOP mode in the same manner as above 1).

#### $\overline{\text{Power-mute}} = L$

Power-mute = L pulse is generated when Power-mute is turned ON or OFF. During the  $\overline{\text{Power-mute}}$  signal = L, the voltage at the point A becomes lower than the emitter voltage of Q424. Subsequently, Q424 and Q426 are turned ON, C411 is charged up to +24 V, and +24 VS is activated in the same manner as above (b).

#### (d) Memory Rewind

During REW mode and with Memory Rewind Switch turned ON, C414 is grounded when the tape counter comes to "999", and Q431 is turned ON pulse-likely.

As a result, Q430 is turned ON, and shut-off is activated resulting in STOP mode.

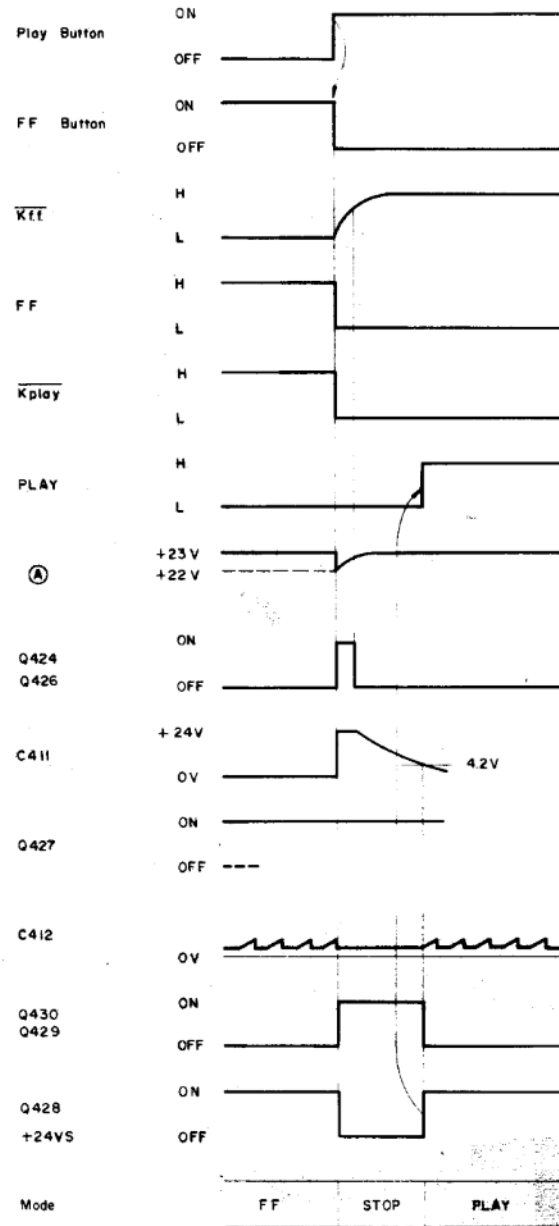

Fig. 2.3.7 Timing Chart

### 2.3.5. Record Control Circuit

Refer to Fig. 2.3.8 circuit diagram.

RECORD mode is set by pressing Record Button, then Play Button together. By pressing Record Button, the  $\overline{Krec.}$  signal becomes L, Q419 is turned ON, Q421 is turned ON, and the record lamp is illuminating. Then, by pressing Play Button further, the  $\overline{Kplay}$  signal becomes L, Q418 is turned ON, the PLAY signal becomes H (+24 VS), and Q420 is turned ON.

Accordingly, the base current flows to Q403 via C406 connected to the base of Q403, and Q403 is turned ON pulse-likely.

The output of Q403 is fed to the control motor drive circuit and acts to bring the cam to the record position.

When Q403 returns to OFF, the cam then moves to the

play position and stays there, thus the mechanism is set to RECORD mode.

Record circuit is designed to protect from the erroneous setting of RECORD mode even if wrong record button operation is made.

Q422 is turned ON during FF or REW mode, or when the cam is set to the play or pause position, i.e., PLAY or PLAY/PAUSE mode. In this case, as D422 is grounded by Q422, Q421 is not turned ON and the record lamp is not lit even if Record Button is further pressed.

Further, the base of Q420 is grounded via D419 and Q422, consequently, Q420 and Q403 are not turned ON and no pulse is output from Q403 to the control motor drive circuit.

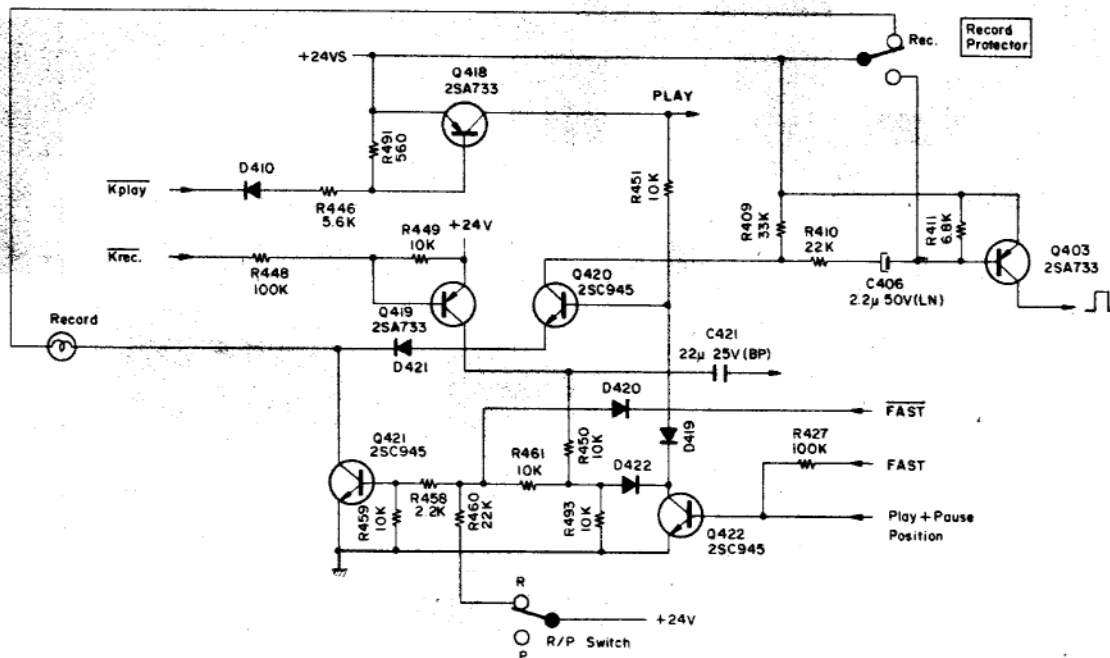

Fig. 2.3.8 Record Control Circuit

### 2.3.6. Mute Signal

Refer to Fig. 2.3.9 circuit diagram.

When Q416 is turned ON, the Mute = H signal is fed to the amp. circuit and the amp. circuit is muted.

The condition that the amplifier circuit is muted are (Mute = H):

$$Q416 \text{ ON} = ((Q412 \text{ ON}) + \overline{\text{PLAY}}) \cdot (\text{R/P Switch} = \text{Play}) + \text{Power-mute}$$

Power-mute: When Power Switch is turned ON or OFF,  $\overline{\text{Power-mute}}$  signal becomes L, i.e., Power-mute signal becomes H, and Q416 is turned ON.

Q412 ON : Cam is in the pause position.

Q412 OFF : Cam is in the play position (i.e., PLAYBACK or RECORD mode).

R/P Switch : When R/P Switch on the Main P.C.B. is in the record position, +24 V is applied, but when it is in the play position, no voltage is applied.

The modes in which the amplifier circuit is not muted are (Mute = L):

$$\begin{aligned} Q416 \text{ OFF} &= \overline{Q416 \text{ ON}} \\ &= \overline{((Q412 \text{ ON}) \cdot \text{PLAY}) + (\text{R/P Switch} = \text{Play}) \cdot \text{Power-mute}} \\ &= ((Q412 \text{ OFF}) \cdot \text{PLAY}) + (\text{R/P Switch} = \text{Record}) \cdot \overline{\text{Power-mute}} \end{aligned}$$

i.e., PLAYBACK mode and RECORD mode.

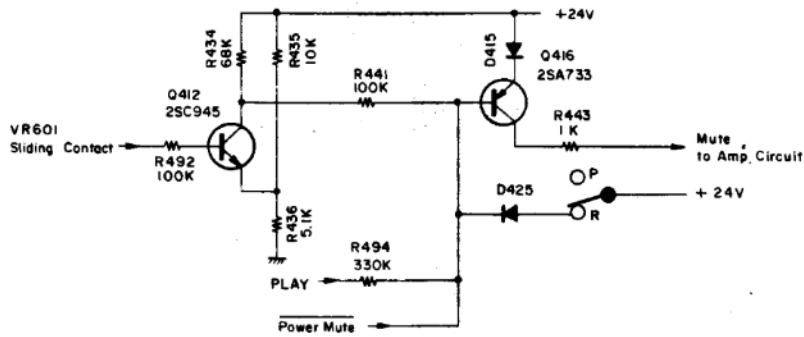

Fig. 2.3.9 Mute Signal Circuit

**Control Motor Drive Circuit**

to Fig. 2.3.10 circuit diagram and Fig. 2.3.11 timing  
 The control motor is turned by varying amounts, depending on which control button is set. This motor is connected to the mechanism control cam, and the mechanism is set to the mode indicated by this cam.  
 The motor is driven by the differential amplifier IC402 and drivers Q405 and Q406. In the control motor condition, both voltages at pins No.5 (non-inverting) and No.6 (inverting input) of IC402 (1/2) are equal. When a new mode is demanded, the balance of both inputs is broken, as a result, the control motor is driven until both inputs are balanced. The cam control variable resistor VR601 is changed synchronously with the motor so that the voltage at the sliding contact of VR601 is changed. When the voltage at the sliding contact of VR601 is changed and the input difference of the differential

amplifier IC402 (1/2) becomes zero, the control motor stops.

The following table shows the relationship between cam position and the voltage at the sliding contact of the cam control variable resistor VR601, and the state of transistors in each mode.

Position on Cam	Typical Voltage at Sliding Contact of Cam Control Volume
Record	16V
Stop	15V
FF/REW	13.5V
Pause	10V
Play	7.5V

Mode	ON		OFF	
	Record	Q403, Q410	Q412	Q404
Stop		Q412	Q403, Q404, Q410	Q411
FF/REW	Q404, Q410	Q412	Q403	Q411
Play/Pause	D417 ON	Q411, Q412	Q403, Q404, Q410	
Play		Q411	Q403, Q404, Q410	Q412

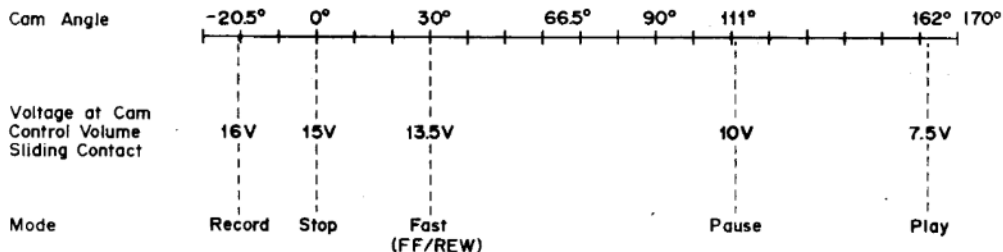



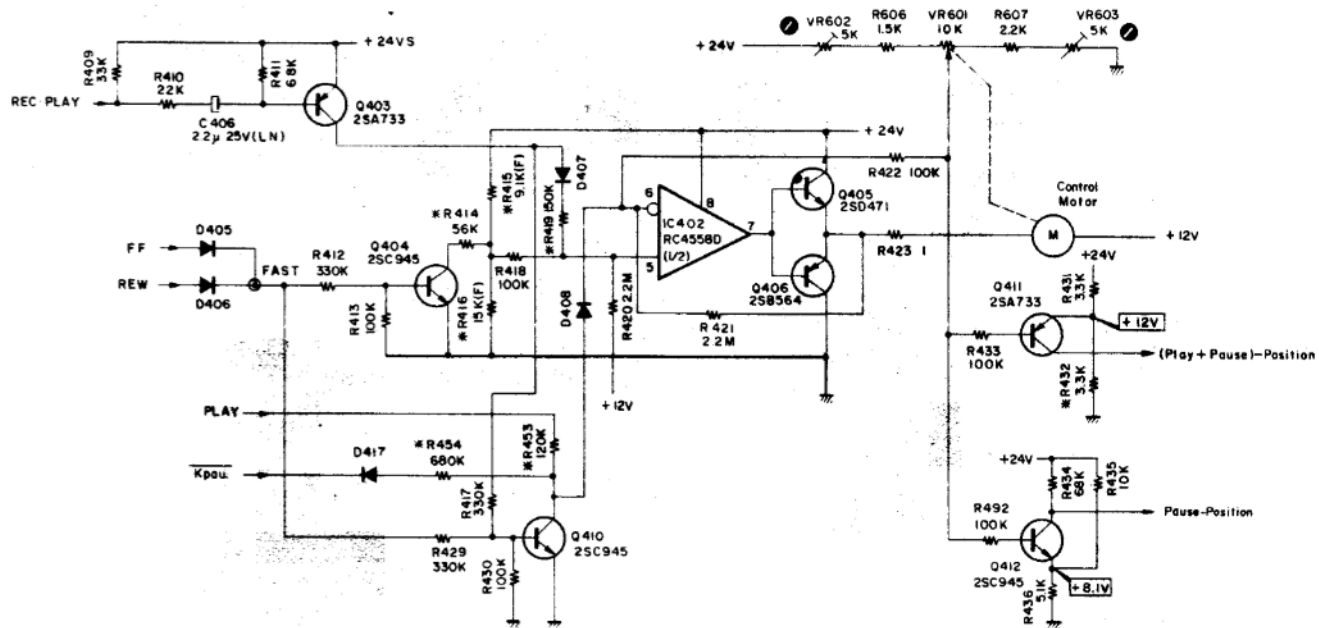

Fig. 2.3.10 Control Motor Drive Circuit

Control Button	STOP	PLAY	FF(REW)	PLAY	PLAY PAUSE	PLAY	STOP	REC/PLAY	REC/PLAY PAUSE	REC/PLAY	FF(REW)	STOP	FF(REW)
Mode	STOP							FF(REW)					
	STOP	PLAY	FF(REW)	PLAY	PLAY PAUSE	PLAY	STOP	REC. PLAY	REC. PLAY PAUSE	REC. PLAY	STOP	STOP	FF(REW)

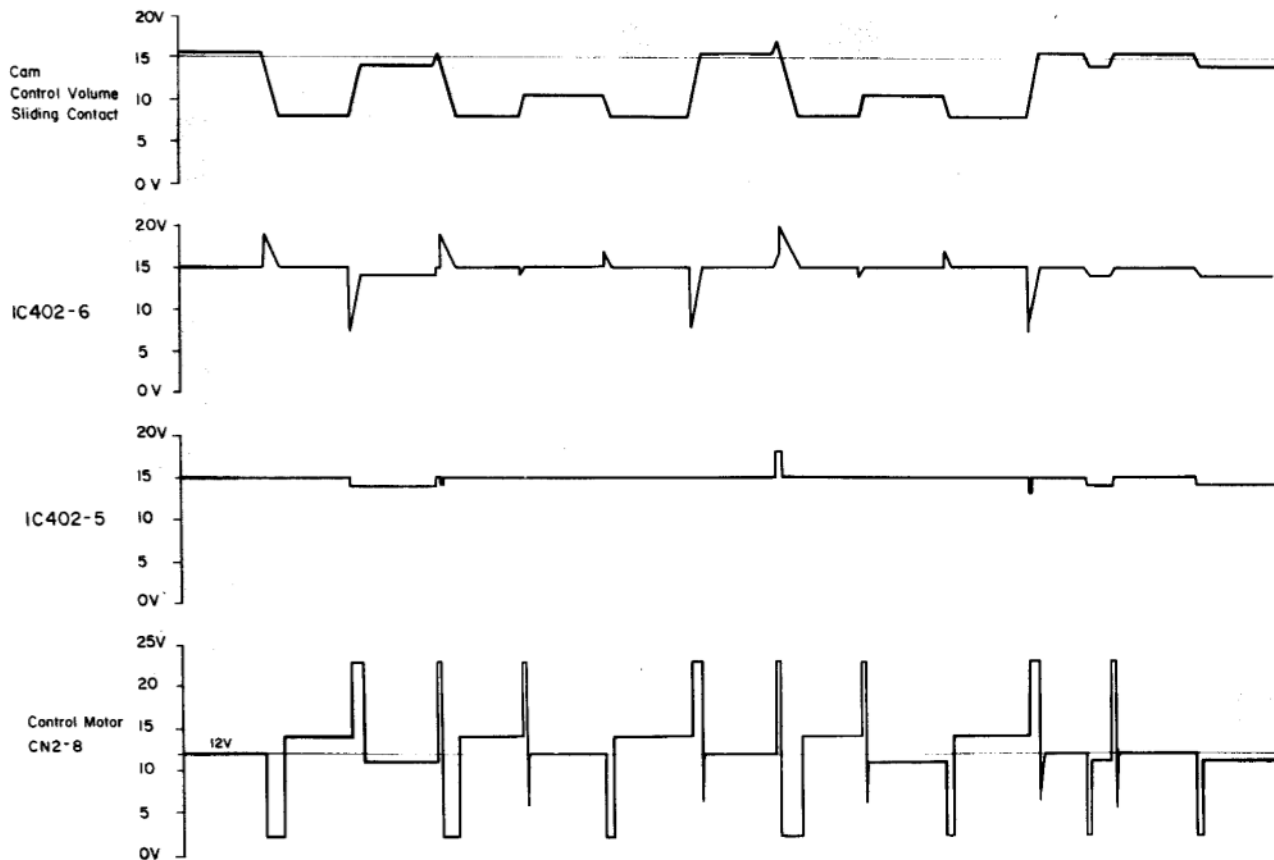

Fig. 2.3.11 Timing Chart

### 3.8. Reel Motor Governor

Refer to Fig. 2.3.12 circuit diagram.

The end of the reel motor is connected with +12 V and the other end is a terminal for controlling.

During FF mode, Q413 is turned ON and the reel motor is grounded. Accordingly, the reel motor turns in the direction of fast-forwarding. On the other hand, during REW mode, +24 V (REW = H) is applied to the reel motor and the reel motor turns in the direction of rewinding. During PLAY (PLAYBACK or RECORD) mode, Q412 is turned OFF and the Pause-position signal becomes H, as a result, Q417 is turned OFF and the reel motor is turned at constant speed by the governor composed of Q414 and

### Q415.

During PLAY/PAUSE mode, Q412 is turned ON and the Pause-position signal becomes L, therefore, Q417 is turned ON, Q414 is biased in the reverse direction, and Q414 is cut off, thus the reel motor does not turn.

Take-up function at loading:

When a cassette tape is inserted and loaded, Eject Switch will become open. Consequently, the base current is applied to Q413 through C409, and Q413 is turned ON pulse-likely. During Q413 is turned ON, the reel motor turns in the direction of fast-forwarding and eliminates tape loosening of the cassette tape if any.

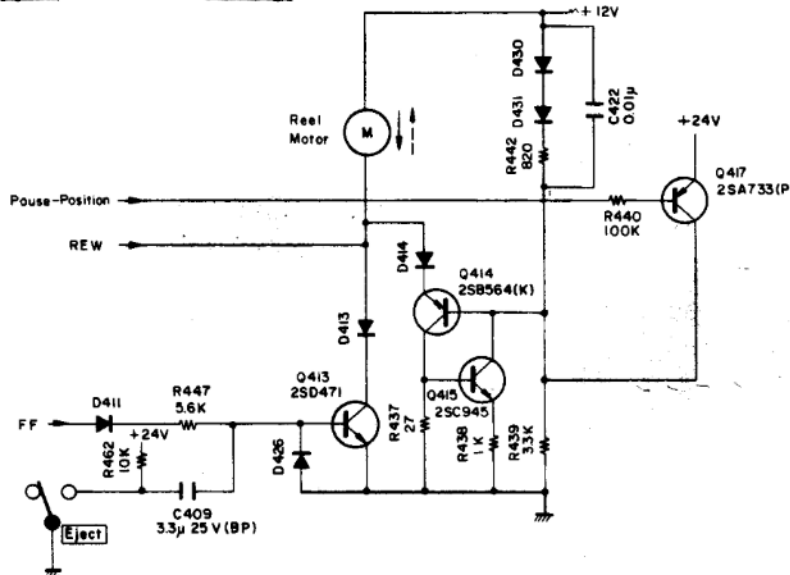

Fig. 2.3.12 Reel Motor Governor

## 3. REMOVAL PROCEDURES

### 3.1. Cassette Case Cover Ass'y

Refer to Fig. 3.1.

- (1) Press the Eject Button to open the Cassette Case Ass'y.
- (2) Pull out F01 (Cassette Case Cover Ass'y) upwardly.

### 3.2. Top Cover Ass'y

Refer to Fig. 3.1.

Remove F02 and F03, then disassemble F04 (Top Cover Ass'y).

### 3.3. Bottom Cover Ass'y

Refer to Fig. 3.1.

Remove F05, then disassemble F06 (Bottom Cover Ass'y).

### 3.4. Front Panel Ass'y

Refer to Fig. 3.2.

- (1) Refer to Fig. 3.1. Remove Top Cover Ass'y and Bottom Cover Ass'y referring to items 3.2 and 3.3.
- (2) Pull out F01 (Volume Knobs).
- (3) Remove F02 (Power Switch Joint Bar) by releasing the self-interlocking pin of the Power Switch Joint Bar from Power Switch, and turn F02 (Power Switch Joint Bar) by 90° either clockwise or counterclockwise, then disassemble F02 (Power Switch Joint Bar) from the Power Switch Knob Ass'y.
- (4) Remove F03, then disassemble F04 (Front Panel Ass'y).

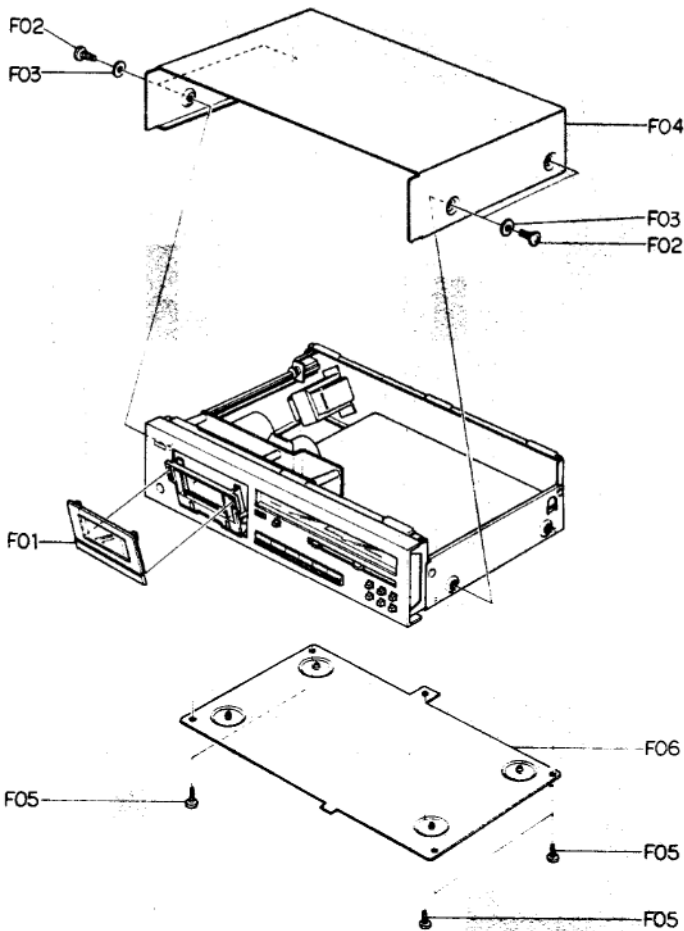

Fig. 3.1

### 3.5. Headphone Jack Ass'y

Refer to Fig. 3.2.

- (1) Remove Front Panel Ass'y referring to item 3.4.
- (2) Remove F05, then disassemble F06 (Headphone Jack Ass'y).

### 3.6. Mechanism Ass'y

Refer to Fig. 3.2.

- (1) Remove Front Panel Ass'y referring to item 3.4.
- (2) Remove F07 and F08, then disassemble F09 (Mechanism Ass'y including 4 connectors and a record switch linkage).

### 3.7. Meter Ass'y

Refer to Fig. 3.2.

- (1) Remove Front Panel Ass'y referring to item 3.4.
- (2) Remove F10 (Meter Ass'y) by releasing self-interlocking pins of the Meter Ass'y.

### 3.8. Lamp P.C.B. R Ass'y and Lamp P.C.B. L Ass'y

Refer to Fig. 3.2.

- (1) Remove Meter Ass'y referring to item 3.7.
- (2) Remove F11 (Lamp P.C.B. R Ass'y) and F12 (Lamp P.C.B. L Ass'y) by releasing the self-interlocking pins.

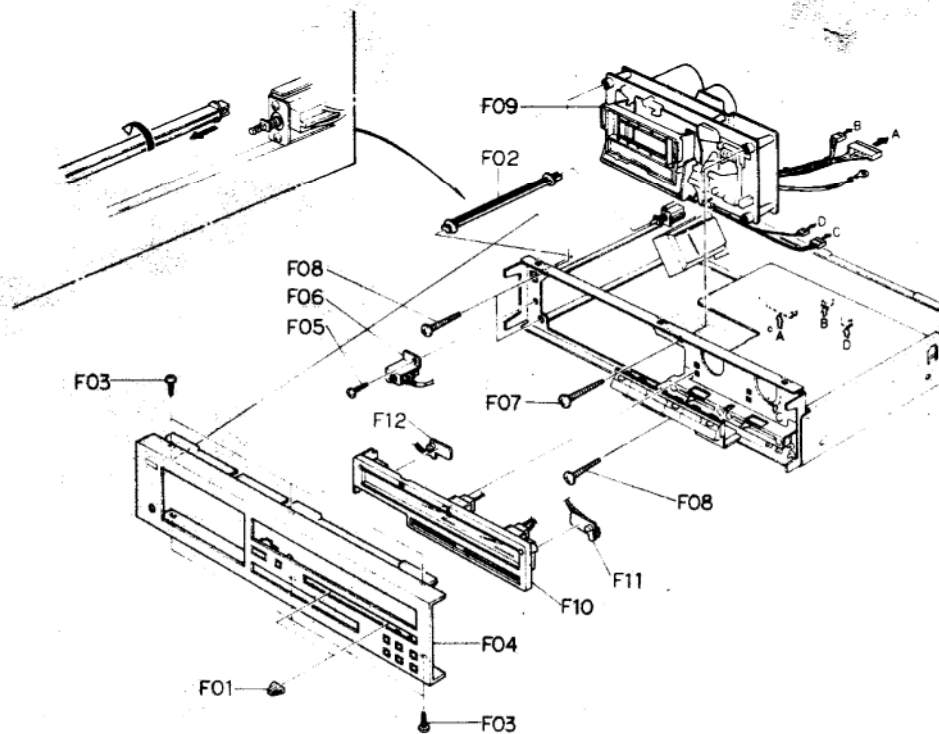

Fig. 3.2

**9. Main P.C.B. Ass'y**

Refer to Fig. 3.3.

- 1) Refer to Fig. 3.2. Remove Front Panel Ass'y referring to item 3.4.
- 2) Remove 4 connectors and the wires connected by wrapping from the F05 (Main P.C.B. Ass'y).
- 3) Remove F01, F02, F03, F04 and the Record Switch Linkage from the Wire Holder assembled with Record Switch, then disassemble F05 (Main P.C.B. Ass'y).

**10. Control Switch Holder Ass'y**

Refer to Fig. 3.3.

- 1) Refer to Fig. 3.2. Remove Meter Ass'y referring to item 3.7.
- 2) Remove F06, then disassemble F07 (Control Switch Holder Ass'y).

**11. Switch P.C.B. Ass'y**

Refer to Fig. 3.3.

- 1) Refer to Fig. 3.2. Remove Front Panel Ass'y referring to item 3.4.
- 2) Remove F08, then disassemble F09 (Switch P.C.B. Ass'y).

**3.12. Volume P.C.B. Ass'y and Control Switch P.C.B. Ass'y**

Refer to Fig. 3.3.

- (1) Remove Control Switch Holder Ass'y referring to item 3.10.
- (2) Remove F10, then disassemble F11 (Volume P.C.B. Ass'y).
- (3) Remove F12, then disassemble F13 (Control Button Spring).
- (4) Remove F14 (Control Button Shaft), then disassemble F15 (Control Buttons).
- (5) Remove F16, then disassemble F17 (Control Switch P.C.B. Ass'y).

**3.13. Rear Panel Ass'y, Power Transformer and Power Switch**

Refer to Fig. 3.4.

- (1) Refer to Fig. 3.1. Remove Top Cover Ass'y and Bottom Cover Ass'y referring to items 3.2 and 3.3.
- (2) Remove F01, F02 and F03, then disassemble F04 (Rear Panel Ass'y).
- (3) Remove F05 and F06, then disassemble F07 (Power Transformer).
- (4) Remove Power Switch Joint Bar by releasing the self-interlocking pin of the Power Switch Joint Bar from Power Switch and F08, then disassemble F09 (Power Switch Holder Ass'y).
- (5) Remove F10, then disassemble F11 (Power Switch).

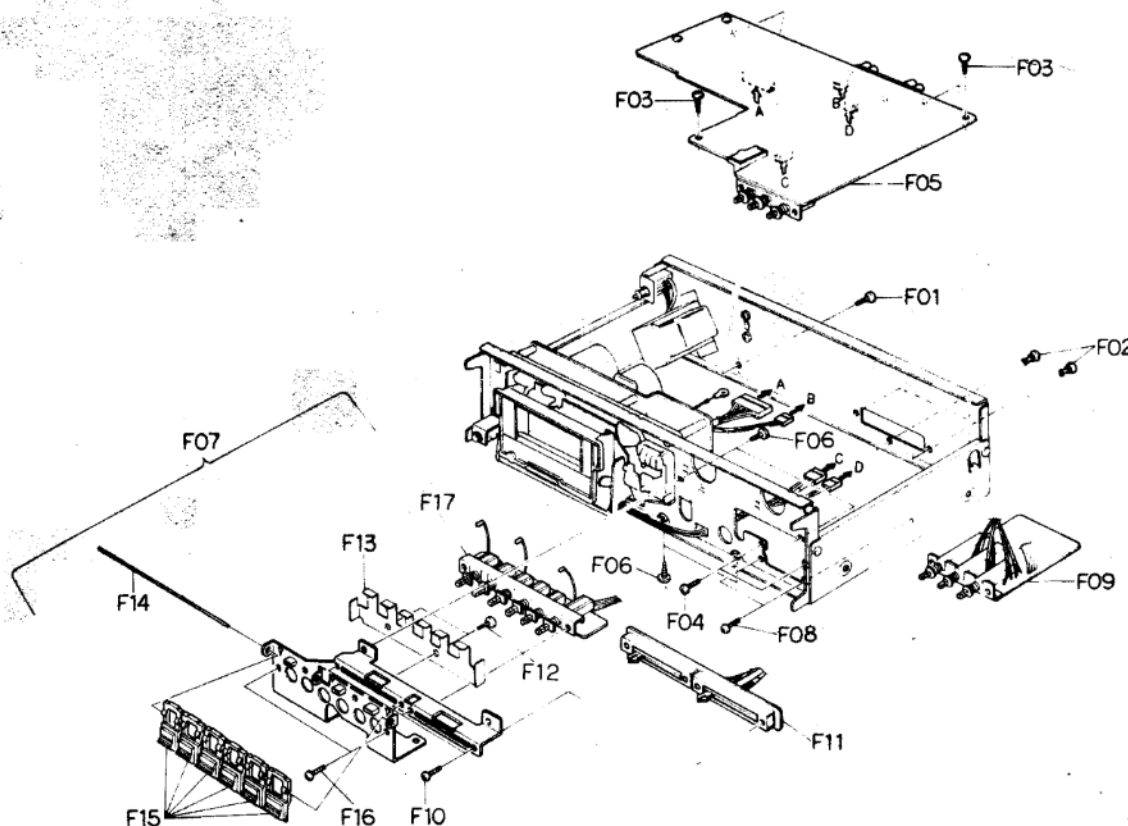

Fig. 3.3

**3.14. Cassette Case Ass'y and Cover Plate Ass'y**

Refer to Fig. 3.5.

- (1) Refer to Fig. 3.2. Remove Mechanism Ass'y referring to item 3.6.
- (2) Press the Eject Button to open the Cassette Case Ass'y.
- (3) Remove F01, then disassemble the piston of the Pneumatic Damper Ass'y.
- (4) Remove F02 and F03 (Cassette Case Holder L Ass'y), then disassemble F04 (Cassette Case Ass'y).

- (5) Remove F05, then disassemble F06 (Cover Plate Ass'y).

**3.15. Tape Counter Ass'y**

Refer to Fig. 3.5.

- (1) Refer to Fig. 3.2. Remove Meter Ass'y referring to item 3.7.
- (2) Remove F07, then disassemble F08 (Tape Counter Ass'y).

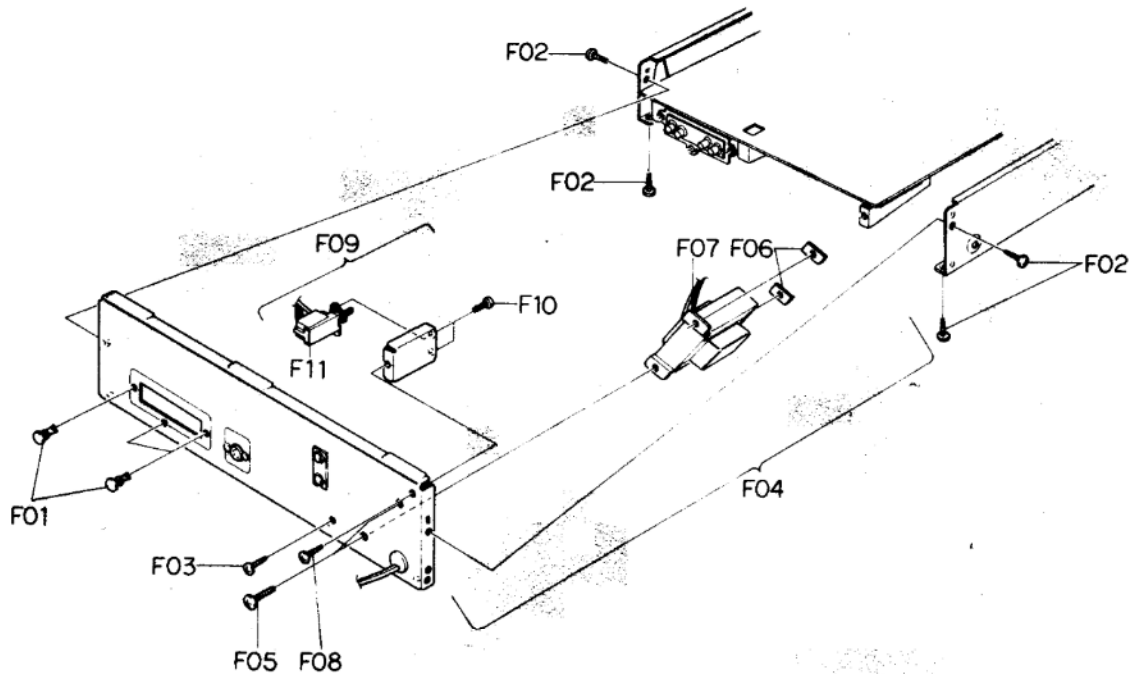

Fig. 3.4

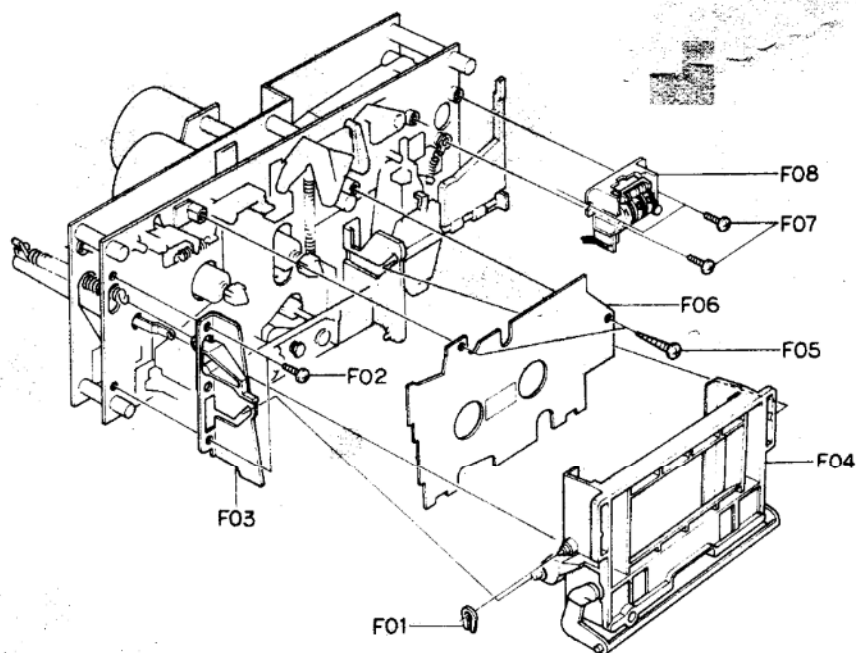

Fig. 3.5

### 3.16. Capstan Motor Ass'y and Flywheel Ass'y

Refer to Fig. 3.6.

- (1) Refer to Fig. 3.2. Remove Mechanism Ass'y referring to item 3.6.
- (2) Remove F01 and F02, then disassemble F03 (Flywheel Holder Ass'y) and F08 (Capstan Belt).
- (3) Remove F04, then disassemble F05 (Capstan Motor Ass'y).
- (4) Remove F06, then disassemble F07 (Control P.C.B. Ass'y).
- (5) Remove F09 (Supply Flywheel Ass'y), then disassemble F10 (Take-up Flywheel Ass'y).
- (6) After removing both Flywheel Assemblies, disassemble F11 (Thrust Washer 3 mm), F12 (Thrust Washer 2.6 mm), F13 (Flange Thrust Caps) and F14 (Thrust Springs).

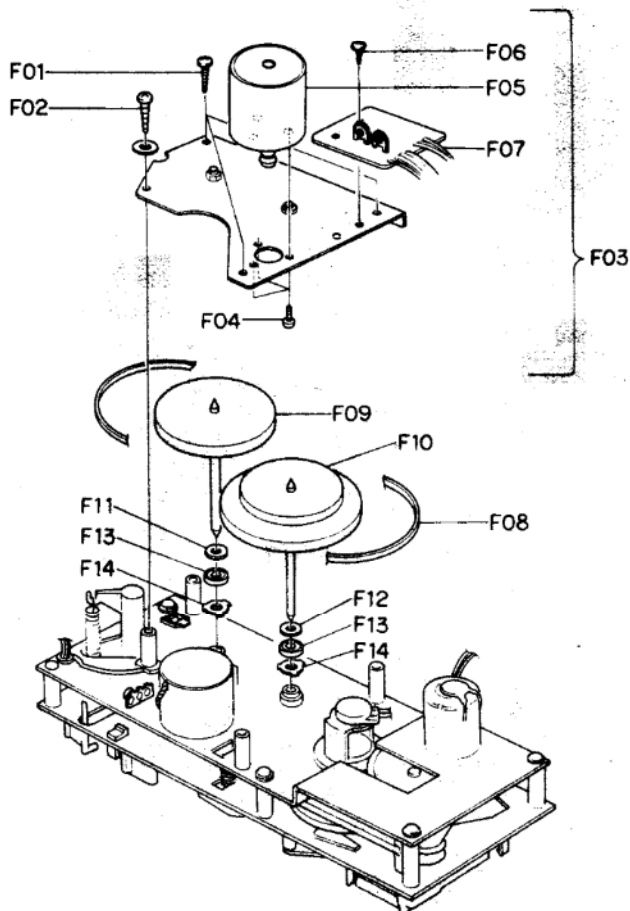

Fig. 3.6

### 3.17. Sub Mechanism Chassis Ass'y

Refer to Fig. 3.7.

- (1) Refer to Fig. 3.6. Remove Flywheel Assemblies referring to item 3.16.
- (2) Remove F01 and F02, then disassemble F03 (Sub Mechanism Chassis Ass'y).

### 3.18. Control Motor Ass'y and Reel Motor Ass'y

Refer to Fig. 3.7.

- (1) Remove Sub Mechanism Chassis Ass'y referring to item 3.17.
- (2) Remove F04, then disassemble F05 (Control Motor Ass'y).
- (3) Remove F06, then disassemble F07 (Reel Motor Ass'y).

### 3.19. Cam Control Volume

Refer to Fig. 3.7.

- (1) Remove Sub Mechanism Chassis Ass'y referring to item 3.17.
- (2) Remove F08, then disassemble F09 (Volume Coupler).
- (3) Remove F10, then disassemble F11 (Cam Control Volume).

### 3.20. Reel Hub Ass'y and Idler Ass'y

Refer to Fig. 3.7.

- (1) Remove Sub Mechanism Chassis Ass'y referring to item 3.17.
- (2) Remove F12 (Reel Hub Heads), then disassemble F13 (Reel Hub B Assemblies), F14 (Reel Hub Take-up Ass'y), F15 (Reel Hub Supply Ass'y), F16 (Back Tension Ass'y) and F17 (Back Tension Spring).
- (3) Remove F18, then disassemble F19 (Idler Ass'y).

### 3.21. Cam Drive Gear and Control Cam

Refer to Fig. 3.7.

- (1) Remove Sub Mechanism Chassis Ass'y referring to item 3.17.
- (2) Remove F20, then disassemble F21 (Cam Drive Gear).
- (3) Remove F22, then disassemble F23 (Counter-Load Arm Ass'y).
- (4) Remove F24, then disassemble F25 (Control Cam).

### 3.22. Head Mount Base Ass'y

Refer to Fig. 3.8.

- (1) Refer to Fig. 3.5. Remove Cassette Case Ass'y referring to item 3.14.
- (2) Remove F01, then disassemble F02 (Head Mount Base Ass'y).

### 3.23. Pressure Roller Ass'y and Erase Head

Refer to Fig. 3.8.

- (1) Remove Head Mount Base Ass'y referring to item 3.22.
- (2) Remove F03 and a washer, then disassemble F04 (Supply Pressure Roller Ass'y).
- (3) Remove F05, then disassemble F06 (Erase Head).
- (4) Remove F07 and a washer, then disassemble F08 (Take-up Pressure Roller Ass'y).

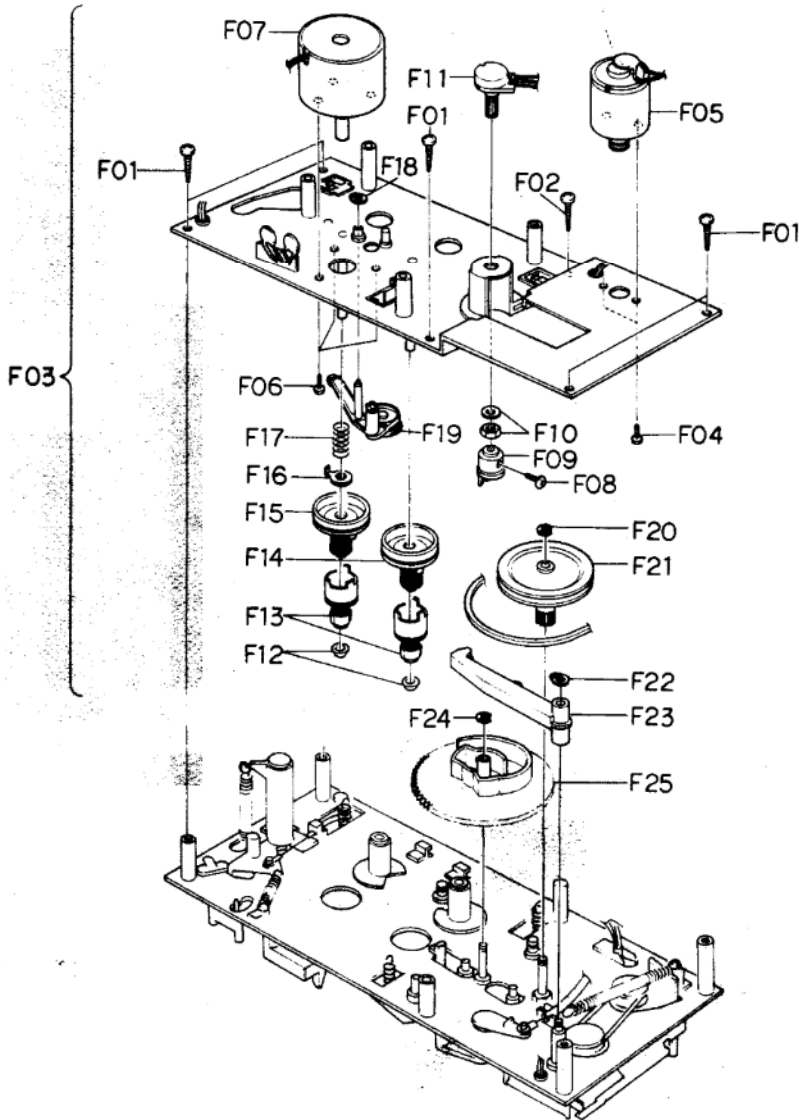

Fig. 3.7

### 3.24. Record/Playback Head Ass'y

Refer to Fig. 3.8.

- (1) Remove Head Mount Base Ass'y referring to item 3.22.
- (2) Turn F09 by 90° by pushing it, then disassemble F10 (Record/Playback Head Ass'y).

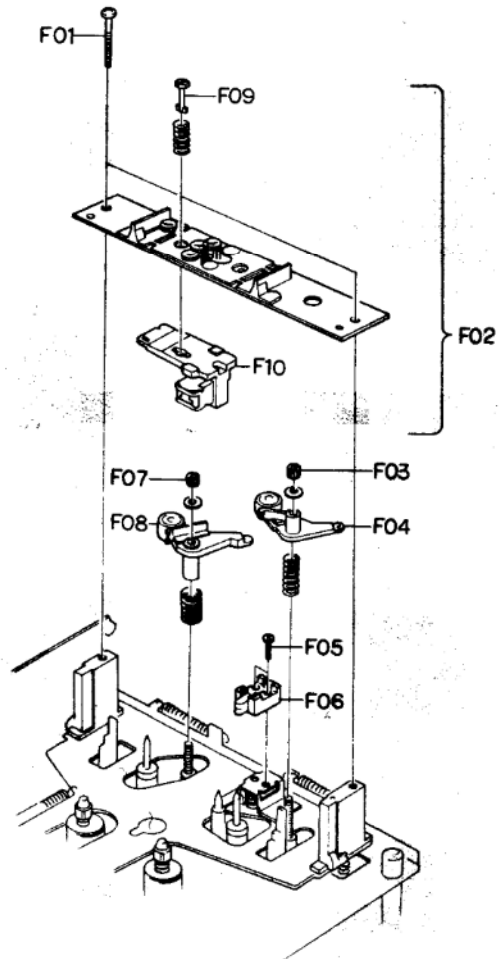

Fig. 3.8

#### 4. MEASUREMENT INSTRUMENTS

- (1) Audio Generator (20 Hz – 200 kHz)
- (2) AC Millivolt Meter (with dB measures)
- (3) Oscilloscope (DC – 5 MHz)
- (4) Distortion Meter
- (5) Speed & Wow/Flutter Meter
- (6) Frequency Counter (DC – 1 MHz)
- (7) Ohm Meter
- (8) DC Volt Meter
- (9) AC Volt Meter
- (10) Torque Gauge (DA09013A)
- (11) 15 kHz Azimuth Tape (DA09004A)
- (12) 3 kHz Speed & Wow/Flutter Tape (DA09006A)
- (13) 1 kHz Track Alignment Tape (DA09007A)
- (14) 400 Hz Level Tape (DA09005A)
- (15) 20 kHz PB Frequency Response Tape (DA09001A)
- (16) 15 kHz PB Frequency Response Tape (DA09002A)
- (17) 10 kHz PB Frequency Response Tape (DA09003A)
- (18) Reference EXII Tape (DA09021A)
- (19) Reference SX Tape (DA09025A)
- (20) Reference ZX Tape (DA09037A)
- (21) Tilt Check Gauge M-9036 (DA09036A)
- (22) Stroke Check Gauge M-9038 (DA09038A)
- (23) EH Tilt Check Gauge M-9040 (DA09040A)
- (24) EH Stroke Check Gauge M-9042 (DA09042A)
- (25) EH Stroke Check Gauge M-9051 (DA09051A)
- (26) Audio Analyzer T-100  
(including Distortion, Wow/Flutter, Speed, Oscillator and dB meter)

- Notes: 1. (10) – (26) are the products of Nakamichi Corporation.
2. EH Stroke Check Gauge M-9042 (DA09042A) should be used for the Models from serial Nos. A304.501001 to A304.516073, and EH Stroke Check Gauge M-9051 (DA09051A) is for the Models bearing serial Nos. A304.516074 and greater.



## 5. MECHANICAL ADJUSTMENTS

### 5.1. Mechanism Control Cam Adjustment

Before Adjustment, disassemble the Front Panel Ass'y then remove the Cover Plate Ass'y, referring to items 3.4 and 3.14.

#### (1) Offset Adjustment of Control Motor Driver

(a) Refer to Figs. 5.1 and 5.2.

Adjust VR602 and VR603 on the Control P.C.B. to locate approximately at the middle of the variable range. Then turn ON the Power Switch.

VR602 (for Cam position stop)

VR603 (for Cam position play)

(b) Press the Stop Switch to set the N-480 in stop mode. Adjust VR602 (for stop) so that the "S" mark on the Cam corresponds to the pointer on the mechanism chassis.

(c) Press the Play Switch to set the N-480 in playback mode.

(Cam will rotate, and the position marked with "PY" comes to the pointer.) Adjust VR603 (for play) so that the "PY" mark on the Cam corresponds to the pointer.

(d) Repeat above (b) and (c) 2 - 3 times so that the "S" and "PY" marks on the Cam correspond to the pointer accurately in stop and playback modes respectively.

(This adjustment is required because the position adjusted by one volume will be slightly changed when the other volume is adjusted.)

(e) Set the N-480 in FF, pause, or record mode by pressing each switch and check to insure that the pointer is in a range of "F", "PS", or "R" mark respectively.

(f) If out of the range, precise adjustment for each position according to "(2) Offset Fine Adjustment of Control Motor Driver" will be required.

#### (2) Offset Fine Adjustment of Control Motor Driver

Adjust only if a satisfactory result is not obtained in "(1) Offset Adjustment of Control Motor Driver". This adjustment is made by changing the value of the fixed resistors on the Main P.C.B.

Note: The value of voltage is typical value.

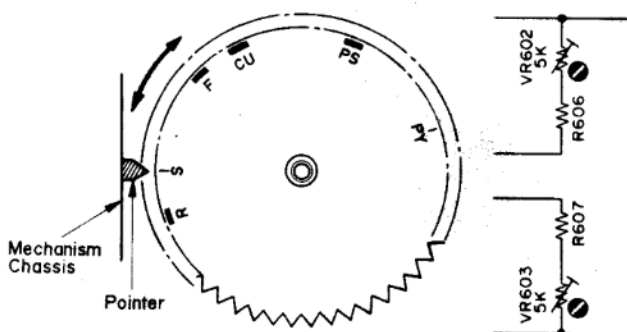

Fig. 5.1

Fig. 5.2

#### (a) Observation Point of Reference Voltage

Observe the each voltage at the sliding contact of the Cam Control Volume VR601 (10 kΩ) in stop, fast (FF or REW), pause, record and playback modes.

Note: When Record and Play Switches are pressed to set N-480 in record mode, the Cam is first set to the record position in a short period of time then stays at the play position.

Therefore to keep the Cam at the record position, following procedure is required:

Short the both leads of capacitor C406 (2.2 μF) on the Main P.C.B. with a jumper wire, then press the Record and Play Switches.

#### (b) Reference Voltage

Reference voltage at the sliding contact of VR601 (Cam Control Volume) in each mode is as follows:

Mode	Reference Voltage (Typical Value)
Record	16 V $\left\{ \begin{array}{l} +0.4 \text{ V} \\ -0.2 \text{ V} \end{array} \right.$
Stop	15 V $\left\{ \begin{array}{l} \\ \end{array} \right.$
Fast (FF/REW)	13.5 V $\left\{ \begin{array}{l} \\ 1.5 \text{ V} \pm 0.25 \text{ V} \end{array} \right.$
Pause	10 V $\left\{ \begin{array}{l} \\ \end{array} \right.$
Play	7.5 V $\left\{ \begin{array}{l} \\ 2.5 \text{ V} \pm 0.4 \text{ V} \end{array} \right.$

#### (c) Resistors for Adjustment

Mode	Ref. No.	Typical Value
Stop	R415, R416	9.1 kΩ(F), 15 kΩ(F)
Fast (FF/REW)	R414	56 kΩ (F)
Pause	R454	680 kΩ
Play	R453	120 kΩ
Record	R419	150 kΩ

#### (d) Adjustment Procedures

1) Press the Stop Switch to set the N-480 in stop mode. Adjust the value of R415 and R416 to obtain 15 V ( $\pm 0.6$  V) at the sliding contact of VR601.

Note: When R415 and R416 are adjusted, the reference voltage in Fast (FF or REW) mode is changed. Therefore, re-check of the reference voltage in Fast (FF or REW) mode is required. If the reference voltage is out of the range, re-adjustment of R414 according to next step 2) is necessary.

2) Set the N-480 in FF mode, then adjust the value of R414 so that the voltage of VR601 will become lower by 1.5 V ( $\pm 0.25$  V) than in stop mode.

3) Press the Pause Switch to set the N-480 in pause mode.

Adjust the value of R454 to obtain 10 V ( $+0.4$ ,  $-0.15$  V) at the sliding contact of VR601.

4) Set the N-480 in playback mode, then adjust the value of R453 so that the voltage of VR601 will be

come lower by 2.5 V ( $\pm 0.4$  V) than in pause mode.

- Short the both leads of capacitor C406 with a jumper wire.

Set the N-480 in record mode, then adjust the value of R419 so that the voltage of VR601 will become higher by 1 V ( $+0.4$ ,  $-0.2$  V) than in stop mode.

Note: Remove the short of C406 after completion of adjustment.

### (3) Cam Timing Adjustment

- Remove the wires from the Control Motor terminals to set the motor open.

- Without loading a cassette tape and with pressing the record protecting switch with your finger tip, press the Record and Play Switches to set the N-480 in record mode.

Turn the Cam and bring the "PY" mark toward the pointer by hand.

Reel Motor will rotate before the "PY" mark reaches the pointer.

Adjust the value of R436 so that the voltage at the sliding contact of VR601 becomes 9.7 V ( $\pm 0.3$  V) when Reel Motor starts rotation.

- Observe the mute signal at the Q416 collector.  
Turn the Cam referring to above step (c) and check to insure that the voltage at the sliding contact of VR601 is 9.5 V ( $\pm 0.3$  V) when mute is released (mute signal changes from H to L).  
(This voltage is determined by the adjustment of R436 in above step (c).)
- Observe the (Play + Pause)—Position signal at the Q411 collector.  
Turn the Cam referring to above step (c) and adjust the value of R432 to obtain 11.2 V ( $\pm 0.4$  V) at the sliding contact of VR601 when (Play + Pause)—Position signal changes from L to H (bias oscillation will begin).
- Upon completion of above adjustment, re-connect wires to the motor terminals.

### 5.2. Tape Speed Adjustment

- Remove the Top Cover.
- Connect a Frequency Counter to the Output Jack.
- Load a 3 kHz Speed Wow/Flutter Tape (DA09006A) and play it back.
- Referring to Fig. 5.3, adjust the Tape Speed Adjustment Volume (VR501) incorporated in the Capstan Motor to obtain 3,000 Hz on the Frequency Counter.

CCW: Motor drives slowly.

CW: Motor drives fast.

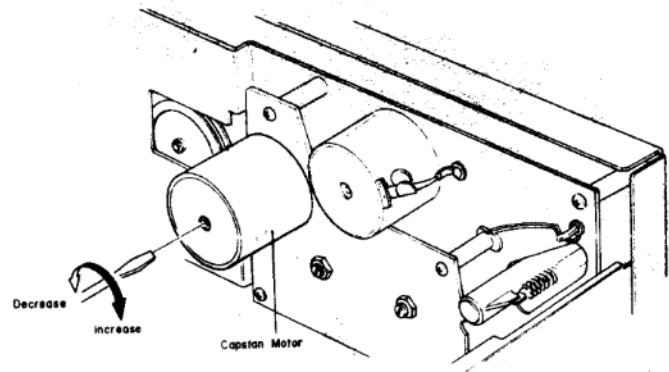

Fig. 5.3

### 5.3. Record/Playback Head Tilt Adjustment

On items 5.3 – 5.7, please refer to Fig. 5.4 flow chart.

Refer to Figs. 5.5 and 5.6.

- Load a Tilt Check Gauge M-9036 (DA09036A) in the N-480.
- Clip the grounding terminal of the Tilt Check Gauge with one end of the cord with clip, and the other end to the chassis of the N-480.
- Remove Height Gear.
- Set the N-480 in play mode. Check to insure whether the Beacon "Upper" or "Lower" is illuminating. In order not to give damages onto the record/playback head surface, push the slide knob of the gauge to the direction of an arrow mark, then return it to the original place to be in contact with record/playback head surface after play mode is securely locked.
- Check to insure freedom from contact between the gauge and pad lifter.
- Beacon "Lower" will light on when height adjustment screw turned clockwise but "Upper" when counterclockwise. Adjust so that both "Upper" and "Lower" will light on even when you move the slide knob to the direction of an arrow mark and then return it to the original place.
- Set the N-480 in stop mode and fit the serrated Height Gear. Then set the N-480 again in play mode and insure 2 Beacons "Upper" and "Lower" are illuminating.  
If not, (3) through (6) will have to be repeated till satisfactory results are obtained.

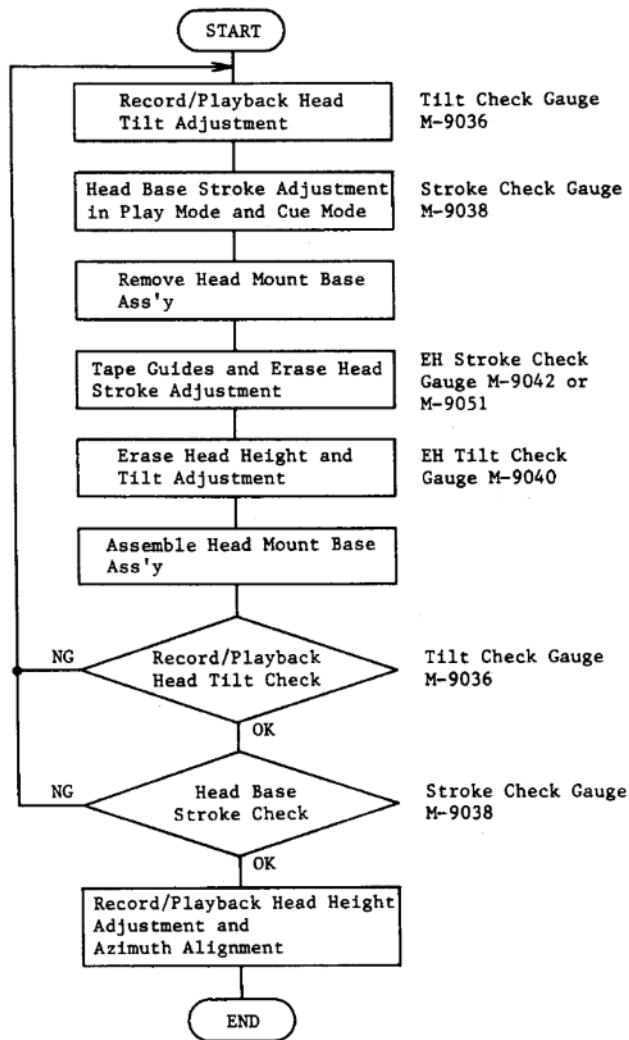

Fig. 5.4

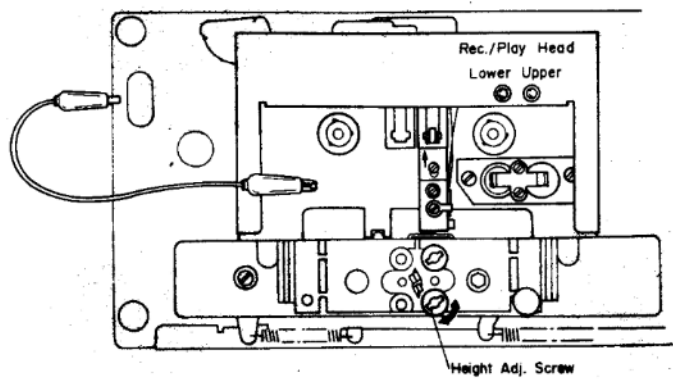

Fig. 5.5

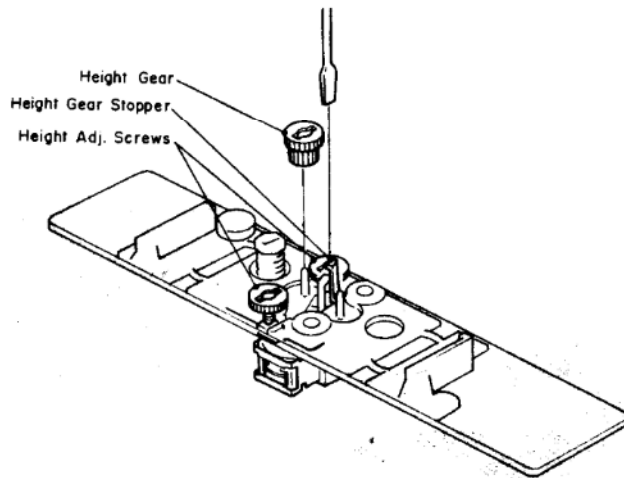

Fig. 5.6

#### 5.4. Head Base Stroke Adjustment

Refer to Fig. 5.7.

Note: Before you conduct "Head Base Stroke Adjustment", adjust with a "Tilt Check Gauge" to insure freedom from tilt on the record/playback head.

- (1) Load a Stroke Check Gauge M-9038 (DA09038A) in the N-480.
- (2) Set the N-480 in play mode.
- (3) Check to insure whether the "P" pointer on the Stroke Indicator locates between 2 lines as marked on the Stroke Check Plate.
- (4) If the record/playback head stroke is noted to be misaligned, adjustment can be made by moving the stroke adjuster assembled in the head base assembly (either forwardly or backwardly).

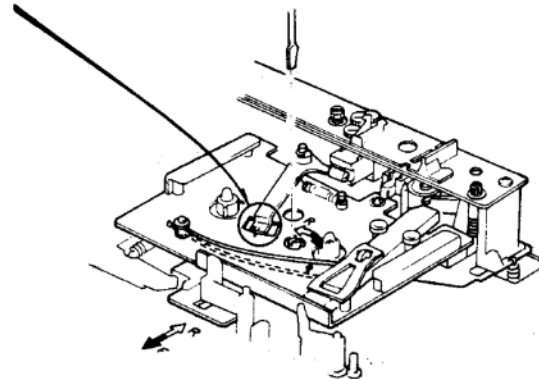
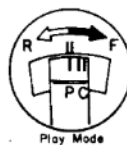

Fig. 5.7

### 5.5. Tape Guides Adjustment and Erase Head Stroke Adjustment

Remove Head Mount Base Ass'y. Refer to Figs. 5.8 and 5.9.

#### (1) Supply Tape Guide Height Adjustment

- (a) Load an EH Stroke Check Gauge M-9042/M-9051 in the N-480.
- (b) Set the N-480 in play mode.
- (c) Slide the Supply Tape Guide Check Bar down against the supply tape guide, thus check can be made on supply tape guide height.
- (d) If the supply tape guide is misaligned, the Supply Tape Guide Check Bar will not come into the supply tape guide. If such is noted, turn to adjust the height adjustment nut A till the Supply Tape Guide Check Bar is accepted by the supply tape guide.
- (e) If the above are insured, set the N-480 in pause mode, then in play mode to see whether adjustments are appropriately made. If not, (b) through (e) will have to be repeated till satisfactory results are obtained.

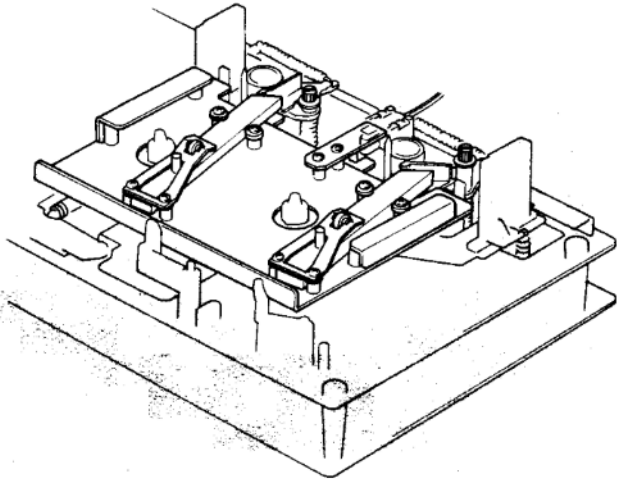

Fig. 5.8

#### (2) Take-up Tape Guide Height Adjustment

- (a) Load an EH Stroke Check Gauge M-9042/M-9051 in the N-480.
- (b) Set the N-480 in play mode.
- (c) Slide the Take-up Tape Guide Check Bar down against the take-up tape guide, thus check can be made on take-up tape guide height.
- (d) If the take-up tape guide is misaligned, the Take-up Tape Guide Check Bar will not come into the take-up tape guide. If such is noted, turn to adjust the height adjustment nut B till the Take-up Tape Guide Check Bar is accepted by the take-up tape guide.
- (e) If the above are insured, set the N-480 in pause mode, then in play mode to see whether adjustments are appropriately made. If not, (b) through (e) will have to be repeated till satisfactory results are obtained.

#### (3) Erase Head Stroke Adjustment

- (a) Load an EH Stroke Check Gauge M-9042/M-9051 in the N-480.
- (b) Set the N-480 in play mode, thus check can be made on erase head stroke through the EH Stroke Indicator.
- (c) Check to insure whether the erase head surface is aligned with red line on the EH Stroke Indicator. If not, adjust the erase head stroke by loosening 2 screws that assembled erase head and erase head plate.
- (d) After completion of adjustment, 2 pcs. of screws shall be locked with lock tight paint.

Note: EH Stroke Check Gauge M-9042 (DA09042A) should be used for the Models from Serial Nos. A304.501001 to A304.516073, and EH Stroke Check Gauge M-9051 (DA09051A) is for the Models bearing Serial Nos. A304.516074 and greater.

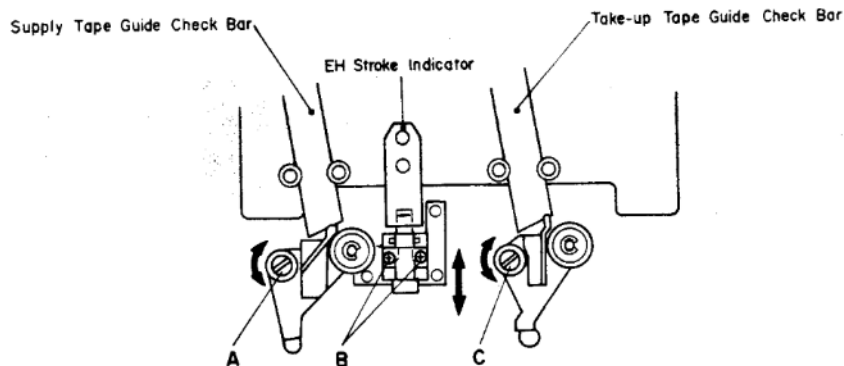

Fig. 5.9

### 5.6. Erase Head Height and Tilt Adjustment

Refer to Figs. 5.10 and 5.11.

- (1) Remove Head Mount Base Ass'y.
- (2) Load an EH Tilt Check Gauge M-9040 (DA09040A) in the N-480.
- (3) Set the N-480 in stop mode.
- (4) Check to insure whether one of the 3 Beacons is illuminating. Look down the mirror as shown by an arrow mark and slowly turn the Screw "Height" counterclockwise (or clockwise) so that the two horizontal lines of the mirror will become superposed on the line (in different color) of the erase head, and check to insure whether Beacon "1" is illuminating.
- (5) Turn Screw "Tilt" counterclockwise (or clockwise) to light on Beacon "2". Excessive turning will cause the Beacon "1" to light off.

Adjustments of Screw "Tilt" will therefore be conducted till both of the Beacons "1" and "2" illuminate.

- (6) Turn Screw "Azimuth" counterclockwise (or clockwise) to light on Beacon "3". Excessive turning will cause either Beacon "1" or "2" to light off, and therefore adjust with Screw "Azimuth" until all of the 3 Beacons "1", "2" and "3" illuminate.
- (7) Check to insure whether the horizontal line on the mirror corresponds to that on the erase head. If not, (4) through (7) will have to be repeated till satisfactory results are obtained.

- (8) After completion of adjustment, 3 pcs. of screws shall be locked with lock tight paint.

Note: Before use of this gauge, check to insure freedom from dust or dirt, or overflow in the groove of the erase head surface.

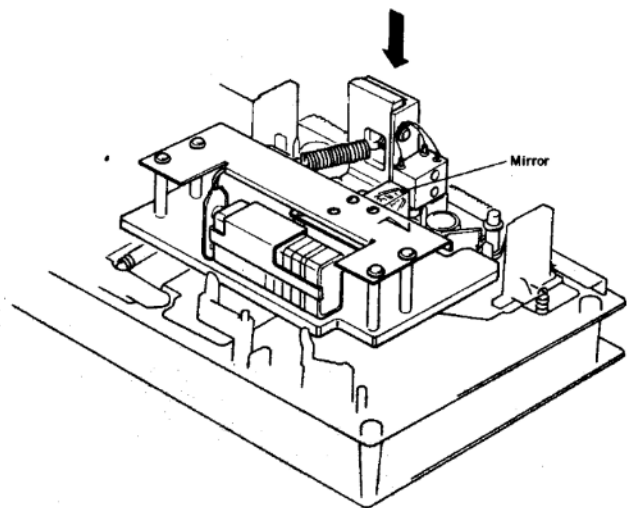

Fig. 5.10

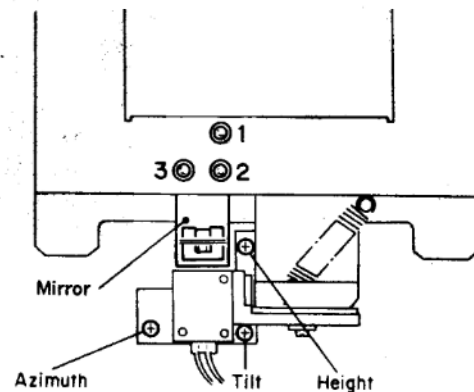

Fig. 5.11

### 5.7. Record/Playback Head Height Adjustment and Azimuth Alignment

Refer to Fig. 5.12.

- (1) Connect a VTVM to the Output Jacks.
- (2) Load a 1 kHz Track Alignment Tape (DA09007A) in the N-480.
- (3) Set the N-480 in play mode.

- (4) Turn the Height Gear until the output of both channels becomes minimum.
- (5) Load a 15 kHz Azimuth Tape (DA09004A) in the N-480.
- (6) Set the N-480 in play mode.
- (7) Turn the Azimuth Alignment Screw until the output of both channels becomes maximum.
- (8) Repeat (2) through (7) 1 - 2 times.

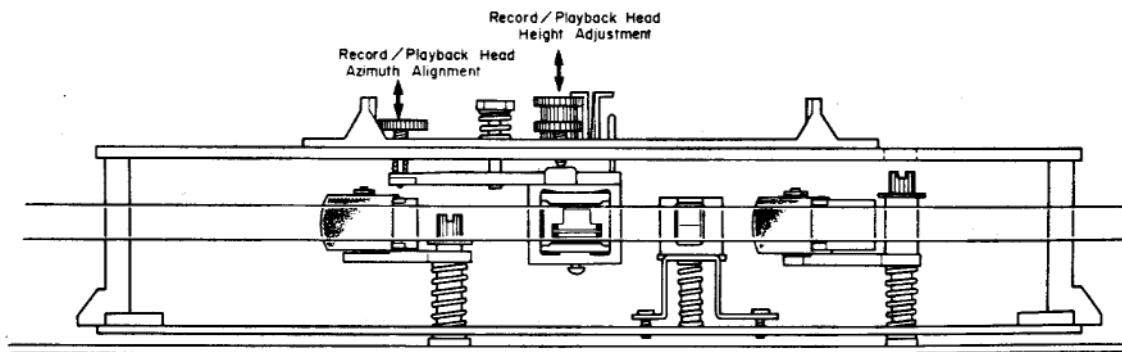

Fig. 5.12

### 5.8. Tape Travelling Adjustment

The adjustment shall be made with a modified version of the current type EXII C-90 tape as shown in the Fig. 5.13 (error will be made if a current type Tape Travelling Cassette (DA09011A) should be used for this purpose). While modifying an EXII C-90 tape, the tape guides in the cassette housing shall be kept protected to avoid tilt.

Check shall be made in the following procedures:

- (1) An EXII C-90 tape thus modified shall be loaded onto the N-480.
- (2) Release the back-tension (rotate the supply reel and feed out some length of tape) and set the N-480 in play mode.
- (3) In this juncture, check to insure whether the tape is freedom from waving or slippage from the both of tape guides.
- 4) When the modified EXII C-90 tape is played back, check to insure whether the tape is freedom from waving from head surface or at pressure rollers.
- (5) If either of waving or slippage from the tape guides should be noted, adjustments of "5.3. Record/Playback Head Tilt Adjustment", "5.4. Head Base Stroke Adjustment", "5.5. Tape Guides Adjustment and Erase Head Stroke Adjustment", "5.6. Erase Head Height and Tilt Adjustment", "5.7. Record/Playback Head Height Adjustment and Azimuth Alignment", etc. will be required.

As a case may be, the said waving or slippage may have been caused from defective Supply Pressure Roller Ass'y or Take-up Pressure Roller Ass'y without parallel contact with Capstans.

If such are noted, the Pressure Roller Assemblies will have to be replaced. Further, excessively weak take-up torque or strong take-up torque may cause defective tape travelling.

The N-480 is intended to be adjustment-free Model. However if the similar matters as above should be noted, please replace the Reel Hub Take-up Ass'y to obtain appropriate take-up torque.

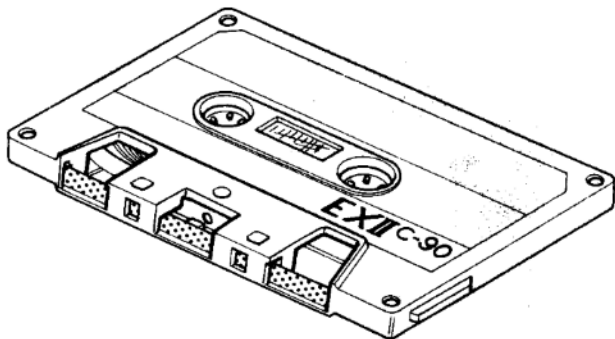

Fig. 5.13

### 5.9. Record Switch Linkage Adjustment

- (1) Set the N-480 in stop mode.
- (2) Loosen the screw of the Record Spring Holder, and shift the Record Spring Holder in order to remove the looseness of the Linkage Wire as shown in Fig. 5.14.1. Then tighten the screws for fixing the Record Spring Holder. (In this case, the Record Switch should be positioned at play side. If on the record position, it will be defective.)
- (3) Set the N-480 in record and pause mode. Check to insure that the gap between the top of the wire and the Record Spring Holder is approx. 1 mm as shown in Fig. 5.14.2. (Check that the Record Switch is in record position.)
- (4) Upon completion of the above adjustments, apply a quantity of lock tight paint.

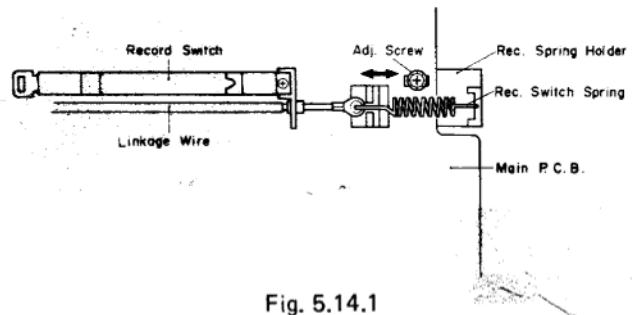

Fig. 5.14.1

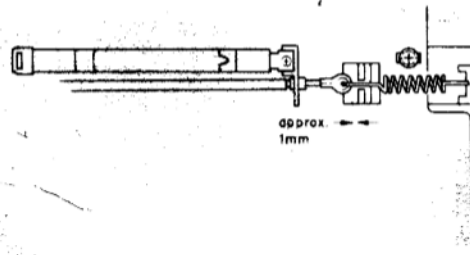

Fig. 5.14.2

### 5.10. Flywheel Holder Adjustment

(1) Refer to Fig. 5.15.

Tighten the Thrust Screws until the gap between the Flywheel Assemblies and Thrust Screws becomes minimized when both of the Capstan Shafts are moved backwardly and forwardly (the Thrust Springs between the Capstan Flanges and Flywheel Thrust Caps are in a flat state).

Excessive tightening of the Thrust Screws however will give damages on the Flywheel Assemblies, to which careful attention is invited.

- (2) Return the Thrust Screws by 1/2 turn.  
(3) Fixing the Thrust Screws with a screwdriver, lock the Lock Nut.  
(4) Apply a quantity of lock tight paint to the Thrust Screws.

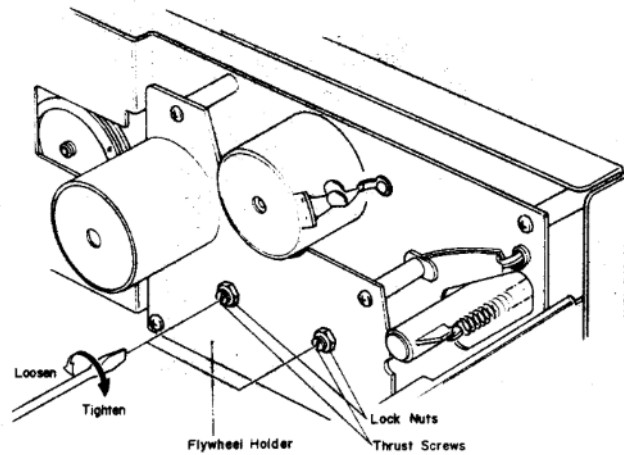

Fig. 5.15

### 5.11. Eject Wire Adjustment

- (1) Referring to Fig. 5.16.1, insert a 1.5 mm spacer between the Eject Arm and Eject Stopper by turning the Eject Arm in the illustrated direction, then set the N-480 in playback mode.  
(2) With pushing the Eject Arm by hand, loosen the screw and then pull the Eject Wire in the direction of the arrow until it stops as shown in Fig. 5.16.2.  
(3) Tighten the screw, then apply a quantity of lock tight paint.

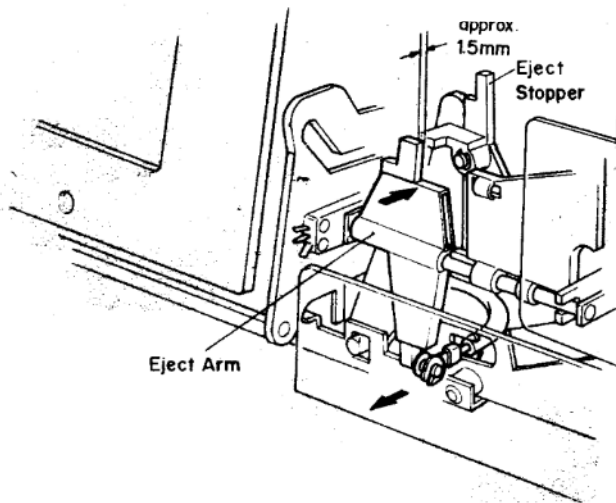

Fig. 5.16.1

### 5.12. Lubrication

N-480 is a lubrication-free cassette deck except when parts are replaced. Apply the following lubricant for each replaced part:

- (1) LAUNA #100  
Capstan Shaft  
Pressure Roller Shaft  
Thrust Cap
- (2) FLOIL GB-TS-1  
Reel Hub Shaft  
Thrust portion on the Capstan Shaft  
FLOIL GB-TS-1, made by Kanto Chemicals Co., Ltd., in Japan.  
We suggest you use the above or equivalent type. If unavailable please contact Kanto Chemicals Co., Ltd., 2-7 Kanda Suda-cho Chiyoda-ku, Tokyo 101 Japan.
- (3) Silicon Oil #3000 CST  
Air Damper Piston  
Note: Excessive lubrication may cause defective damper action as the 0.2φ hole at the end of the cylinder may be filled with oil.

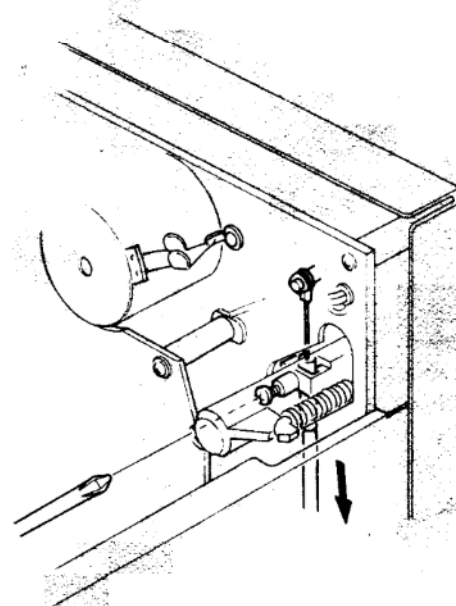
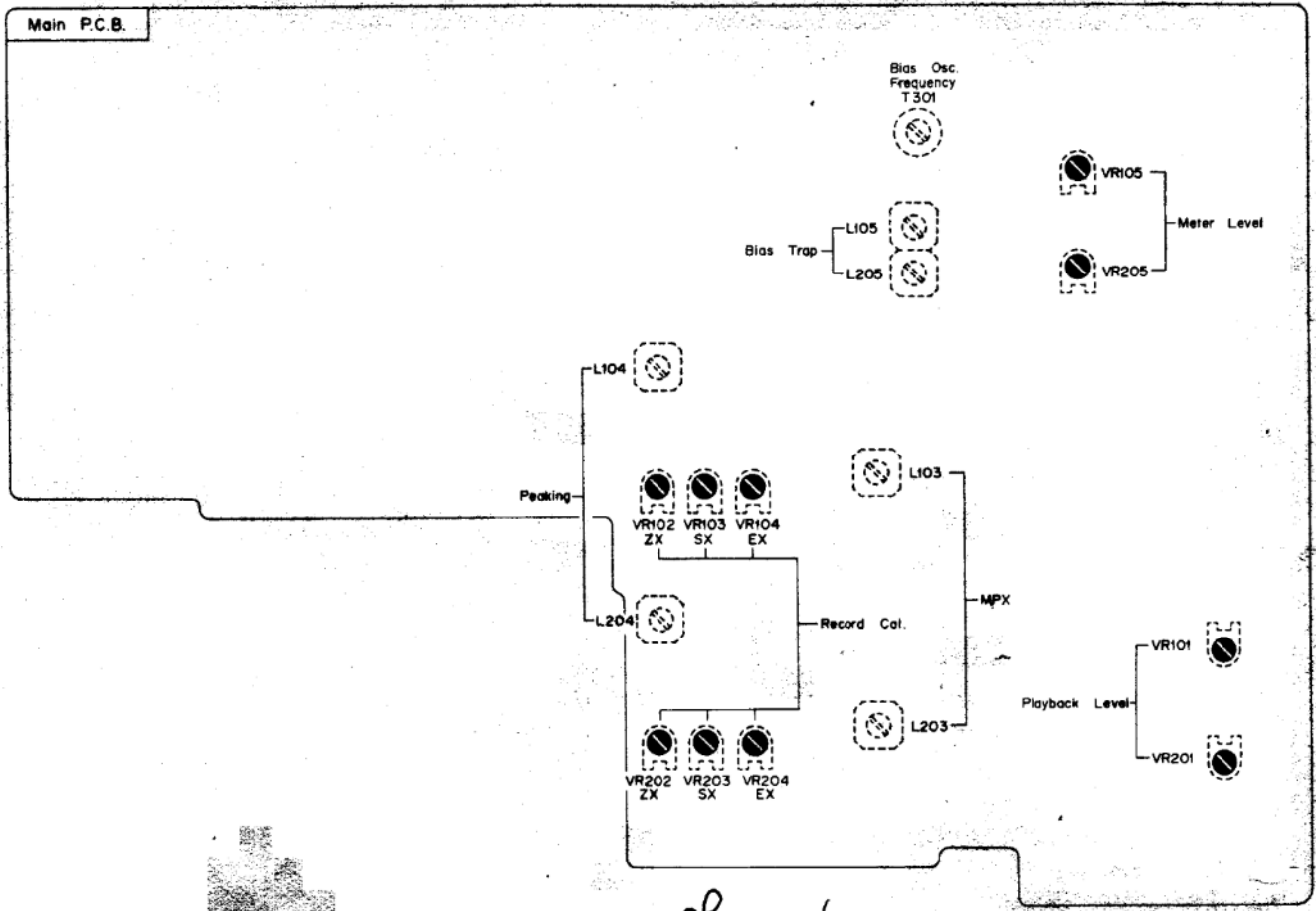

Fig. 5.16.2

# 6. PARTS LOCATION FOR ELECTRICAL ADJUSTMENT



*ohm meter  
 on 20kΩ ZX tape*

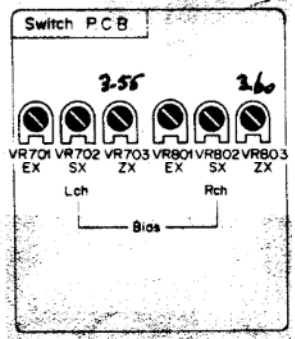
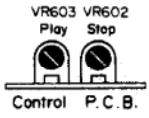

Fig. 6



## 7. ELECTRICAL ADJUSTMENTS AND MEASUREMENTS

### 7.1. Adjustment and Measurement Instructions

Note: Electrical adjustment should be performed after mechanical adjustment is completed.

STEP	ITEM	SIGNAL SOURCE	OUTPUT CONNECTION	M
1	Tape Speed	3 kHz Speed and Wow/Flutter Tape (DA09006A)	Frequency Counter to OUTPUT Jacks	Playback Eq. SW – 70
2	Meter Level	400 Hz to INPUT Jacks	VTVM to TP101, TP201 on the Main P.C.B.	Record, Paus
3	MPX Filter	19 kHz $\pm$ 100 Hz to INPUT Jacks	VTVM to OUTPUT Jacks	Record, Paus MPX SW – 0
4	Record/Playback Head Track Alignment	1 kHz Track Alignment Tape (DA09007A)	Same as above	Playback MPX SW – 0 Eq. SW – 70 Dolby NR SV
5	Record/Playback Head Azimuth Alignment	15 kHz Azimuth Tape (DA09004A)	Same as above	Same as above
6	Playback Level	400 Hz Level Tape (DA09005A)	VTVM to TP101, TP201	Same as above
7	Playback Frequency Response	400 Hz Level Tape (DA09005A) 10 kHz PB Frequency Tape (DA09003A) 15 kHz PB Frequency Tape (DA09002A) 20 kHz PB Frequency Tape (DA09001A)	VTVM to OUTPUT Jacks	Same as above

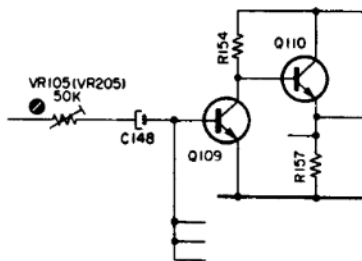

Fig. 7.1  
2. Meter Level

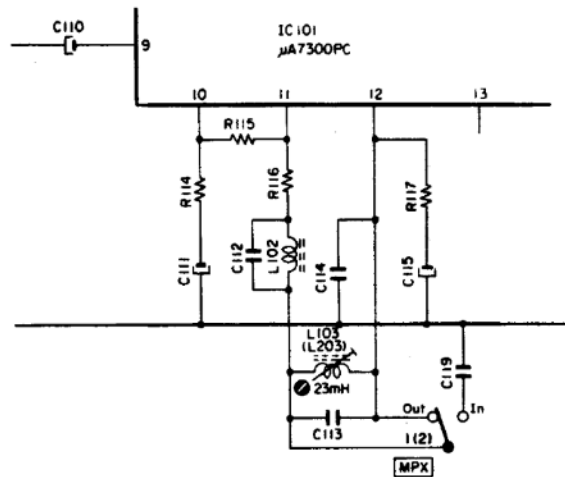

Fig. 7.2  
3. MPX Filter

MODE	ADJUSTMENT	REMARKS
Playback Eq. SW — 70 $\mu$ s	Capstan Motor Governor P.C.B. VR501	Adjust VR501 to obtain 3 kHz $\pm$ 0.5%. (VR501 is incorporated in the capstan motor.)
Record, Pause	Main P.C.B. VR105, VR205	1. Set the input level controls to maximum. 2. Adjust the oscillator output to obtain 100 mV at TP101 (TP201), then adjust VR105 (VR205) to obtain 0 dB on the level meters.
Record, Pause MPX SW — OUT/IN	Main P.C.B. L103, L203	1. Adjust input level controls to obtain 600 mV on the VTVM. 2. Set the MPX Switch to IN position, then adjust L103 (L203) to obtain minimum reading on the VTVM (minimum reading will be less than -30 dB).
Playback MPX SW — OUT Eq. SW — 70 $\mu$ s Dolby SW — OUT	Record/Playback Head Height Ad- justment Screw	Adjust the Record/Playback Head Height Adj. Screw to obtain minimum reading of both L and R channels on the VTVM. See "Record/Playback Head Height Adjustment and Azimuth Alignment" in item 5.7.
Same as above	Record / Playback Head Azimuth Alignment Screw	Adjust the Record/Playback Head Azimuth Alignment Screw to obtain maximum reading of both L and R channels on the VTVM. See "Record/Playback Head Height Adjustment and Azimuth Alignment" in item 5.7. Note: Repeat steps 4 and 5 one or two times to obtain optimum performance.
Same as above	Main P.C.B. VR101, VR201	Adjust VR101 (VR201) to obtain 100 mV on the VTVM or 0 dB on the level meters.
Same as above	Main P.C.B. R112, R212	1. Load the 400 Hz level tape and play it back. 2. Load the 10 kHz, 15 kHz and 20 kHz PB Frequency Response Tapes and adjust the record/playback head azimuth to give maximum levels on the VTVM with each tape. Short R112 (R212) to obtain the following levels against 400 Hz level tape. Refer to Fig. 7.3. 10 kHz (-20 dB) -2 dB to + 2 dB 15 kHz (-20 dB) -2 dB to + 3 dB 20 kHz (-20 dB) -2 dB to + 4 dB 3. Conduct step 5 "Record/Playback Head Azimuth Alignment" 4. If above is not sufficient, refer to "Playback Frequency Response Adjustment" in item 7.2.

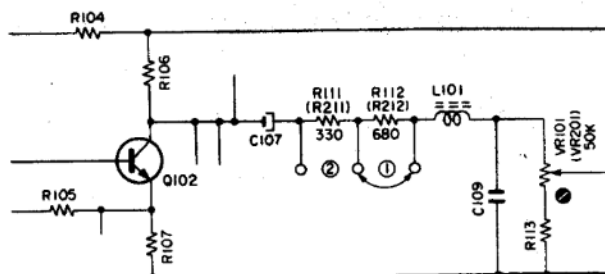

Fig. 7.3

6. Playback Level
7. Playback Frequency Response

STEP	ITEM	SIGNAL SOURCE	OUTPUT CONNECTION	
8	Bias Oscillation Frequency and Erase Current	External 0.1 $\Omega$ Resistor in series to Erase Head	VTVM and Frequency Counter across the 0.1 $\Omega$ Resistor	Record, P; ZX SW – Eq. SW – Dolby NR MPX SW -
9	Record Amplifier Equalizer	21 kHz (-20 dB) to INPUT Jacks	VTVM to TP102, TP202	Same as at
10	Bias Trap	Remove INPUT Signals	Same as above	Same as at
11	Record Level Calibration	400 Hz to INPUT Jacks	VTVM to OUTPUT Jacks	Record an ZX SW – SX/EX SV Eq. SW –  Dolby NR MPX SW -
12	Recording Bias Current and Overall Frequency Response	400 Hz to INPUT Jacks and 20 Hz to 18 kHz (-20 dB) to INPUT Jacks	VTVM and Distortion Meter to OUTPUT Jacks	Record an ZX SW – SX/EX SV Eq. SW –  Dolby NR MPX SW -

MODE	ADJUSTMENT	REMARKS
Record, Pause ZX SW – IN Eq. SW – 70 $\mu$ s Dolby NR SW – OUT MPX SW – OUT	Main P.C.B. T301 R310, R311	<ol style="list-style-type: none"> <li>Adjust T301 to obtain 105 kHz on the frequency counter.</li> <li>Check the erase current by the VTVM. Erase current will be in a range of 310 mA to 400 mA (typically approx. 350 mA). If erase current is not sufficient, increase it by shorting R310 or R311.</li> <li>After completion of the erase current adjustment, re-check the bias oscillation frequency.</li> </ol>
Same as above	Main P.C.B. L104, L204	<ol style="list-style-type: none"> <li>Remove the bias-cut-jumper from the dip side of the Main P.C.B.</li> <li>Adjust L104 (L204) to obtain peak reading at 21 kHz on the VTVM.</li> <li>Re-solder the bias-cut-jumper.</li> </ol>
Same as above	Main P.C.B. L105, L205	Adjust L105 (L205) to obtain maximum reading on the VTVM.
Record and Playback ZX SW – IN/OUT SX/EX SW – SX/EX Eq. SW – 120 $\mu$ s (EX) 70 $\mu$ s (SX/ZX) Dolby NR SW – OUT MPX SW – OUT	Main P.C.B. VR102, VR202 VR103, VR203 VR104, VR204	<ol style="list-style-type: none"> <li>Set the input level controls to obtain 0 dB on the level meters.</li> <li>Record signals on the reference EXII (DA09021A), reference SX (DA09025A) or reference ZX (DA09037A), then play it back.</li> <li>Repeating 2 as above, adjust VR104 (VR204) (for EXII), VR103 (VR203) (for SX) and VR102 (VR202) (for ZX) to obtain 0 dB on the level meters in playback mode.</li> </ol>
Record and Playback ZX SW – IN/OUT SX/EX SW – SX/EX Eq. SW – 120 $\mu$ s (EX) 70 $\mu$ s (SX/ZX) Dolby NR SW – OUT MPX SW – OUT	Switch P.C.B. VR701, VR801 VR702, VR802 VR703, VR803	<ol style="list-style-type: none"> <li>Feed in 400 Hz and adjust input level controls to obtain 0 dB on the level meters.</li> <li>Record signals on the reference EXII tape (DA09021A), reference SX tape (DA09025A), or reference ZX tape (DA09037A).</li> <li>Repeating 2 as above, play back the tape and adjust VR701 (VR801) (for EXII), VR702 (VR802) (for SX) or VR703 (VR803) (for ZX) to obtain maximum reading on the VTVM.</li> <li>Conduct step 11 "Record Level Calibration".</li> <li>Feed in 10 kHz (-20 dB) then record and play it back. Adjust VR104 (VR204) (for EXII), VR103 (VR203) (for SX) or VR102 (VR202) (for ZX) on the Main P.C.B. Ass'y to obtain approximately -20 dB on the VTVM. Feed in 18 kHz (-20 dB) then record and play it back. Adjust recording peaking coil L104 (L204) to obtain approximately -20 dB on the VTVM (refer to step 9 "Record Amplifier Equalizer").</li> <li>Conduct step 11 "Record Level Calibration".</li> <li>Feed in 400 Hz and adjust the input level controls to obtain 0 dB on the level meters, then record and play it back and check to insure whether the Total Harmonic Distortion (T.H.D.) is less than 1.0% for EXII, 1.2% for SX and 1.0% for ZX. Feed in 20 Hz to 18 kHz (-20 dB) then record and play it back, and check to insure whether the output levels are within -20 dB <math>\pm</math> 4 dB.</li> <li>If T.H.D. exceeds 1.2%, the following adjustments are required:             <ol style="list-style-type: none"> <li>Repeat 5 as above. Adjust bias calibration semi-fixed volumes and peaking coils to obtain -22 dB instead of -20 dB on the VTVM.</li> <li>Perform step 11 "Record Level Calibration".</li> <li>Repeat 7 as above.</li> <li>If above is not sufficient, precise re-adjustment of step 7 "Playback Frequency Response", replacement of Record/Playback Head or check of item 5.8 "Tape Travelling Adjustment" will be required.</li> </ol> </li> <li>Conduct step 11 "Record Level Calibration".</li> </ol>

STEP	ITEM	SIGNAL SOURCE	OUTPUT CONNECTION	MODE
13	Crosstalk	1 kHz to INPUT Jacks	1 kHz Band Pass Filter and VTVM to OUTPUT Jacks	Record and Playback ZX SW – OUT SX/EX SW – SX Eq. SW – 70 $\mu$ s Dolby NR SW – OL MPX SW – IN
14	Channel Separation	1 kHz to INPUT Jacks	Same as above	Same as above
15	Erase	100 Hz to INPUT Jacks	100 Hz Band Pass Filter and VTVM to OUTPUT Jacks	Record and Playback ZX SW – IN Eq. SW – 70 $\mu$ s Dolby NR SW – OL MPX SW – IN
16	Signal to Noise Ratio	400 Hz to INPUT Jacks	IHF-A Curve Filter, Distortion Meter and VTVM to OUTPUT Jacks	Record and Playback ZX SW – IN Eq. SW – 70 $\mu$ s Dolby NR SW – IN MPX SW – IN
17	Total Harmonic Distortion	400 Hz to Input Jacks	Distortion Meter to OUTPUT Jacks	Record and Playback ZX SW – IN/OUT SX/EX SW – SX/E Eq. SW – 120 $\mu$ s (E) 70 $\mu$ s (SX) Dolby NR SW – OL MPX SW – IN
18	Wow/Flutter	3 kHz Speed and Wow/Flutter Tape (DA09006A)	Wow/Flutter Meter to OUTPUT Jacks	Playback Eq. SW – 70 $\mu$ s

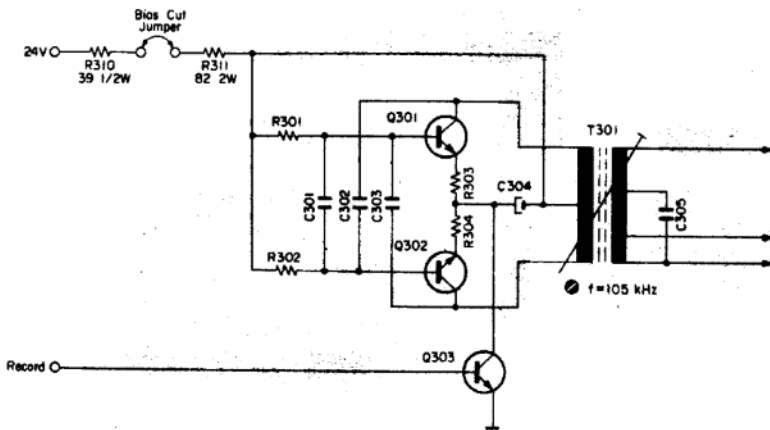

Fig. 7.4 8. Bias Oscillation Frequency and Erase Current

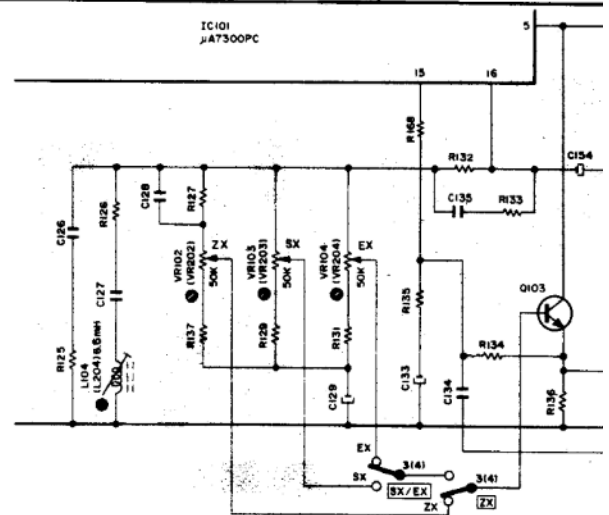

Fig. 7.5 9. Record Amplifier Equal  
10. Bias Trap  
11. Record Level Calibration

MODE	ADJUSTMENT	REMARKS
and Playback - OUT SW - SX - 70 $\mu$ s IR SW - OUT V - IN		<ol style="list-style-type: none"> <li>1. Erase the tape with bulk eraser.</li> <li>2. Adjust the input level controls to obtain 0 dB on the level meters, and record the signals on the reference SX tape (DA09025A).</li> <li>3. Turn the cassette tape the other way round and play it back.</li> <li>4. Measure the difference between 2 and 3.</li> </ol>
above		<ol style="list-style-type: none"> <li>1. Erase the tape with bulk eraser.</li> <li>2. Adjust L ch (R ch) input level control to obtain 0 dB on the level meter, and close R ch (L ch) input level control.</li> <li>3. Record and play it back, then measure the R ch (L ch) level.</li> </ol>
and Playback - IN IR SW - OUT V - IN		<ol style="list-style-type: none"> <li>1. Erase the tape with bulk eraser.</li> <li>2. Adjust input level controls to obtain 0 dB on the level meters, and record the signals on the reference ZX tape (DA09037A).</li> <li>3. Rewind the tape, close input level controls, and then record again.</li> <li>4. Rewind the tape, play it back, and then measure the difference between 2 and 3.</li> </ol>
and Playback - IN - 70 $\mu$ s IR SW - IN V - IN		<ol style="list-style-type: none"> <li>1. Feed in 400 Hz and record, and play it back.</li> <li>2. Adjust the input level controls to obtain 3% total harmonic distortion in playback mode.</li> <li>3. Close the input level controls then record.</li> <li>4. After rewind, play back and check the output level difference between 2 and 3.</li> </ol> <p>Note: The filter of IHF-A curve shall be used in the measurements.</p>
and Playback - IN/OUT SW - SX/EX - 120 $\mu$ s (EX) 70 $\mu$ s (SX, ZX) IR SW - OUT V - IN		<ol style="list-style-type: none"> <li>1. Adjust the input level controls to obtain 0 dB on the level meters.</li> <li>2. Record and play it back.</li> <li>3. Read the distortion meter and check to insure that the distortion is as follows:  EXII ..... 1.0% or less  SX ..... 1.2% or less  ZX ..... 1.0% or less</li> </ol>
k		Playback and read the wow/flutter meter.

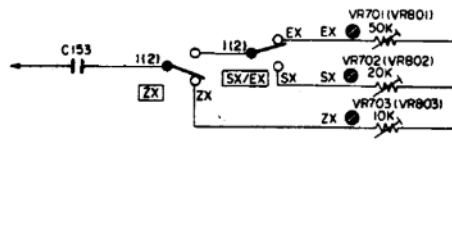
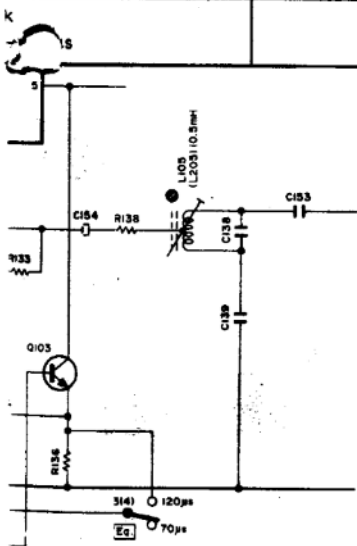

Fig. 7.6 12. Record Bias Current and Overall Frequency Response

fier Equalizer  
Calibration

**7.2. Playback Frequency Response Adjustment**

Fig. 7.7 shows the playback equalization curve for the N-480, and Fig. 7.8 is the circuit for adjustment.

**(1) Level Adjustment (for middle frequency response)**

This adjustment will be required when playback level is not sufficient at 10 kHz PB Frequency Response Tape (refer to step 7 in "7.1. Adjustment and Measurement Instructions").

Playback equalization level can be varied by the modification of R108 (R208) and R109 (R209).

Following are the details for level modification:

Approx. +1 dB	R108 (R208): 2 k
	R109 (R209): 2.4 k
0 dB	R108 (R208): 1.8 k
	R109 (R209): 2.2 k
Approx. -1 dB	R108 (R208): 1.6 k
	R109 (R209): 2 k

**(2) Peaking Adjustment (for high frequency response)**

This adjustment will be required when playback level is not sufficient at 20 kHz PB Frequency Response Tape (refer to step 7 "7.1. Adjustment and Measurement Instructions").

Peaking portion compensates the gap loss of the playback head. Peaking level is varied by the short circuit of R112 (R212) or R111 (R211) as illustrated in the figure.

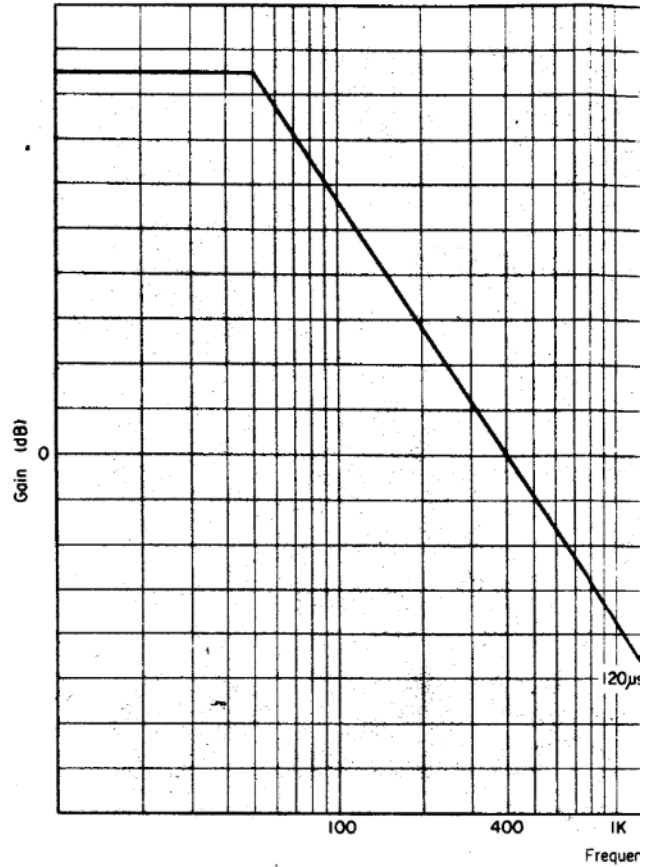

Fig. 7.7 Playback Eq

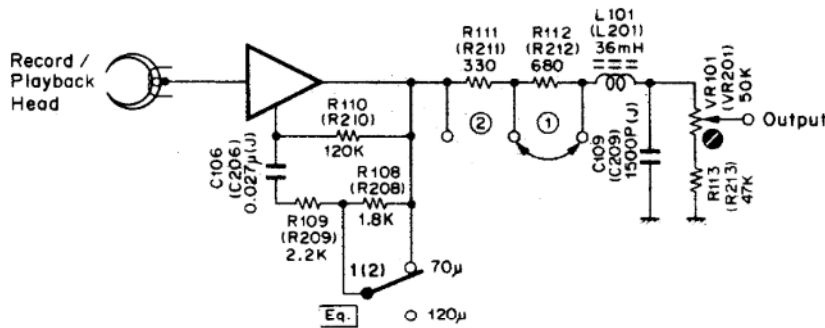
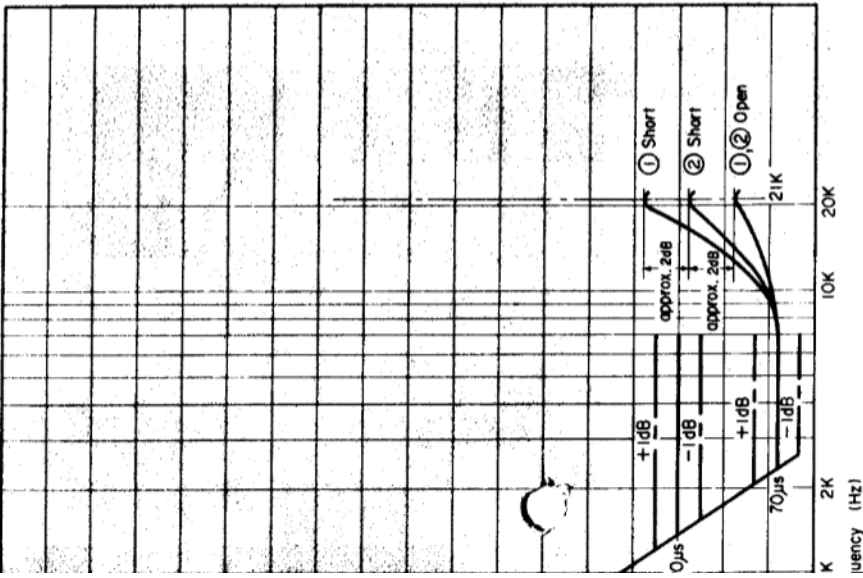

Fig. 7.8 Playback Amp.



Equalization Curve

### 7.3. Check on Dolby NR Circuit

Dolby NR Circuit incorporates a Dolby B-Type NR IC ( $\mu$ A7300PC) which has no adjustment point. Perform the following checks and make sure that the IC operates accurately i.e., frequency response through IC is accurate.

Signal Source: 5 kHz to INPUT Jacks

Output Connection: VTVM to the output side of C154 (C254) on the Main P.C.B.

Mode: Record Pause  
MPX SW — IN

- (1) Remove the Bias-cut Jumper from the dip side of the Main P.C.B.
- (2) Connect a VTVM to TP101 (TP201) on the Main P.C.B.  
Feed in 5 kHz and adjust the input level so that the VTVM may read 100 mV (0 dB) at each Test Point. Pointer on the meter will indicate 0 dB.
- (3) Remove the VTVM from TP101 (TP201) and reconnect it to the output side of C154 (C254).
- (4) Decrease the input level (0 dB) by 20 dB or 30 dB. Check to insure that the level at output side of C154 (C254) corresponds to the following with the Dolby NR Switch IN and OUT.
- (5) After completion of the adjustment, reconnect the Bias-cut Jumper.

Input Level (f=5 kHz)	Capacitor Output Level		
	Dolby NR OUT	Dolby NR IN	Difference between IN and OUT
-20 dB	-20 dB	-16.8 dB $\pm$ 1.5 dB	3.2 dB $\pm$ 1.5 dB
-30 dB	-30 dB	-21.8 dB $\pm$ 1.5 dB	8.2 dB $\pm$ 1.5 dB



Note: Diode is 1SS53 unless otherwise specified.

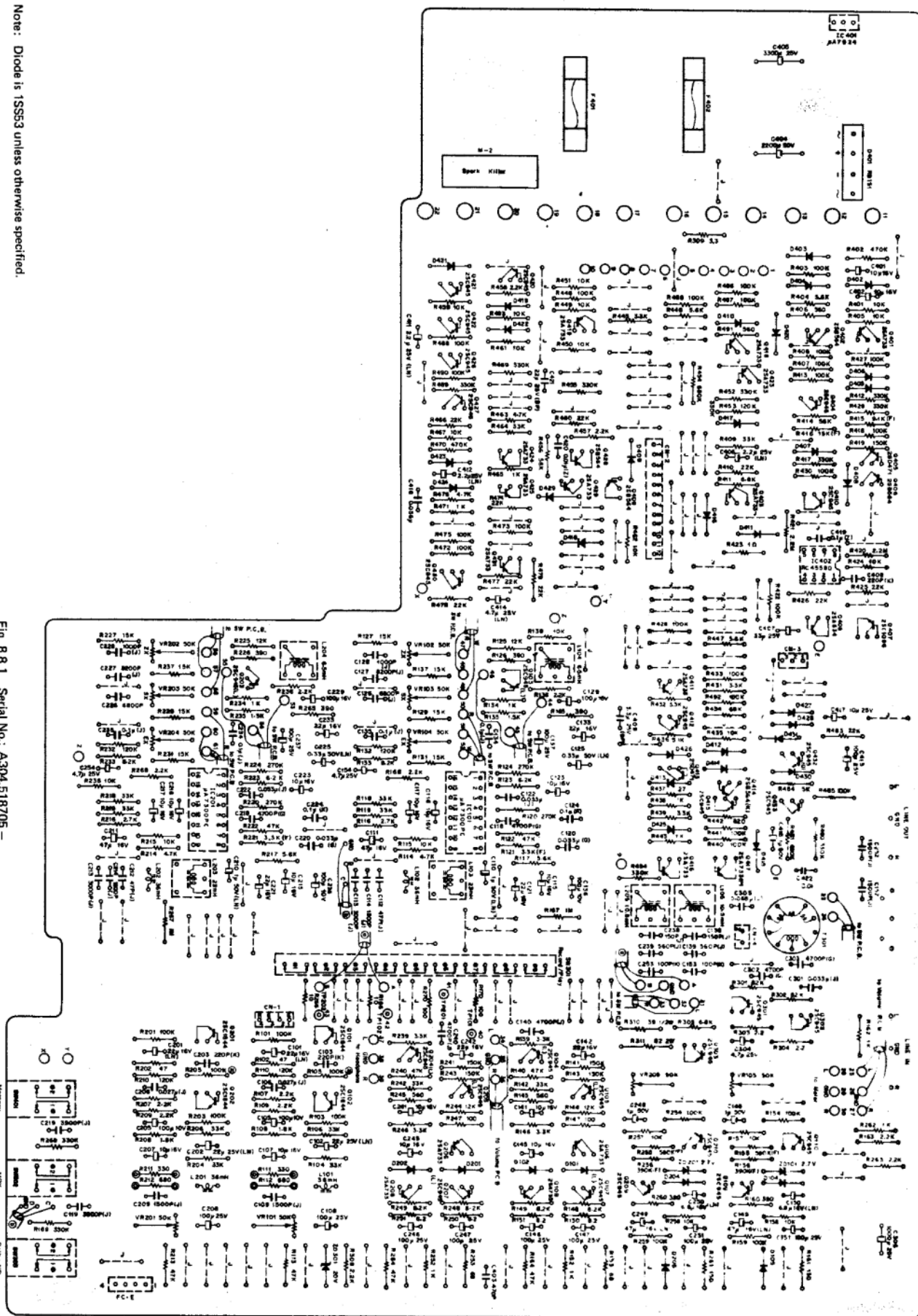

Fig. B.8.1 Serial No.: A304.518705 -



Part No.	Description	Schematic Ref. No.	Part No.	Description	Schematic Ref. No.
1680A	Carbon Resistor 820 ERD-25T J		0805614A	Carbon Resistor 1.8K ERD-25T J	
1621A	Carbon Resistor 120K ERD-25T J		0801857A	Carbon Resistor 1K ERD-25T J	
1315A	Carbon Resistor 680K ERD-25T J		0805621A	Carbon Resistor 120K ERD-25T J	
1622A	Carbon Resistor 2.2K ERD-25T J		0805335A	Carbon Resistor 800K ERD-25T J	
1846A	Carbon Resistor 4.7K ERD-25T J		0805622A	Carbon Resistor 2.2K ERD-25T J	
1094A	Carbon Resistor 470K ERD-25T J		0801846A	Carbon Resistor 4.7K ERD-25T J	
1683A	Carbon Resistor 15K ERD-25T J		0801684A	Carbon Resistor 470K ERD-25T J	
1286A	Ceramic Capacitor 470pF 50V K		0801683A	Carbon Resistor 15K ERD-25T J	
1332A	Electrolytic Capacitor 2.2μ 25V (LN)		0809285A	Ceramic Capacitor 470pF 50V K	
1251A	Electrolytic Capacitor 33μ 25V		0809332A	Electrolytic Capacitor 2.2μ 25V (LN)	
1283A	Ceramic Capacitor 220pF 50V K		0809251A	Electrolytic Capacitor 33μ 25V	
1345A	Electrolytic Capacitor 3.3μ 25V (BP)		0809283A	Ceramic Capacitor 220pF 50V K	
1333A	Electrolytic Capacitor 4.7μ 25V (LN)		0809345A	Electrolytic Capacitor 3.3μ 25V (BP)	
1272A	Electrolytic Capacitor 100μ 25V		0809333A	Electrolytic Capacitor 4.7μ 25V (LN)	
1405A	Electrolytic Capacitor 1μ 50V		0801272A	Electrolytic Capacitor 100μ 25V	
1674A	Electrolytic Capacitor 10μ 25V		0801405A	Electrolytic Capacitor 1μ 50V	
1676A	Mylar Capacitor 0.056μ 50V		0801674A	Electrolytic Capacitor 10μ 25V	
1292A	Ceramic Capacitor 0.1μ 50V Z		0801676A	Mylar Capacitor 0.056μ 50V	
1290A	Ceramic Capacitor 0.01μ 50V Z		0809292A	Ceramic Capacitor 0.1μ 50V Z	
1365A	Electrolytic Capacitor 22μ 25V (BP)		0809290A	Ceramic Capacitor 0.01μ 50V Z	
			0809368A	Electrolytic Capacitor 22μ 25V (BP)	
	<b>over Supply</b>			<b>- Power Supply -</b>	
1237A	Regulator +24V μA7824		0806237A	Regulator +24V μA7824	
1183A	Diode Bridge RB151		0806183A	Diode Bridge RB151	
1181A	Silicon Diode 1S553		0806181A	Silicon Diode 1S553	
1339A	Fail Safe Type Resistor 3.3 RSF-25S J		0809339A	Fail Safe Type Resistor 3.3 RSF-25S J	
1898A	Carbon Resistor 10K ERD-25T J		0801898A	Carbon Resistor 10K ERD-25T J	
1694A	Carbon Resistor 470K ERD-25T J		0801694A	Carbon Resistor 470K ERD-25T J	
1870A	Electrolytic Capacitor 1000μ 25V		0801870A	Electrolytic Capacitor 1000μ 25V	
1412A	Electrolytic Capacitor 10μ 16V		0801412A	Electrolytic Capacitor 10μ 16V	
1336A	Electrolytic Capacitor 2200μ 50V		0809336A	Electrolytic Capacitor 2200μ 50V	
1373A	Electrolytic Capacitor 3300μ 25V		0809373A	Electrolytic Capacitor 3300μ 25V	
	<b>Miscellaneous -</b>			<b>- Miscellaneous -</b>	
1847H	Main P.C.B.		0807847D	Main P.C.B.	
1857A	Carbon Resistor 1K ERD-25T J (2 pcs.)		0801857A	Carbon Resistor 1K ERD-25T J (2 pcs.)	
1386A	Fuse 1A 250V (Japan)		0808686A	Fuse 1A 250V (Japan)	
1374A	Fuse 1A 250V (U.S.A., Canada & Others)		0808374A	Fuse 1A 250V (U.S.A., Canada & Others)	
1275A	Fuse T 1.25mA 250V (UK, Australia & 220V Class 2)		0808275A	Fuse T 1.25mA 250V (UK, Australia & 220V Class 2)	
1698A	Fuse 500mA 250V (U.S.A., Canada & Others)		0808698A	Fuse 500mA 250V (U.S.A., Canada & Others)	
1697A	Fuse 500mA 250V (Japan)		0808697A	Fuse 500mA 250V (Japan)	
1457A	Fuse T 500mA 250V (UK, Australia & 220V Class 2)		0808457A	Fuse T 500mA 250V (UK, Australia & 220V Class 2)	
1363A	Spark Killer (Japan)		0808363A	Spark Killer (Japan)	
1412A	Spark Killer (U.S.A. & Canada)		0808342A	Spark Killer (U.S.A. & Canada)	
1400U	Spark Killer (UK, Australia & Others)		0808240U	Spark Killer (UK, Australia & Others)	
1454A	Spark Killer (220V Class 2)		0808445A	Spark Killer (220V Class 2)	
1054A	4P-T Post		0808654A	4P-T Post	
1681A	12P-T Post		0808681A	12P-T Post	
1653A	3P-T Post		0808653A	3P-T Post	
1656A	2P-T Post		0808656A	2P-T Post	
1239A	Record Switch		0807239A	Record Switch	
1033A	Push Switch		0807239A	Record Switch	
1675A	Pin Jack				
1676A	Heat Sink				

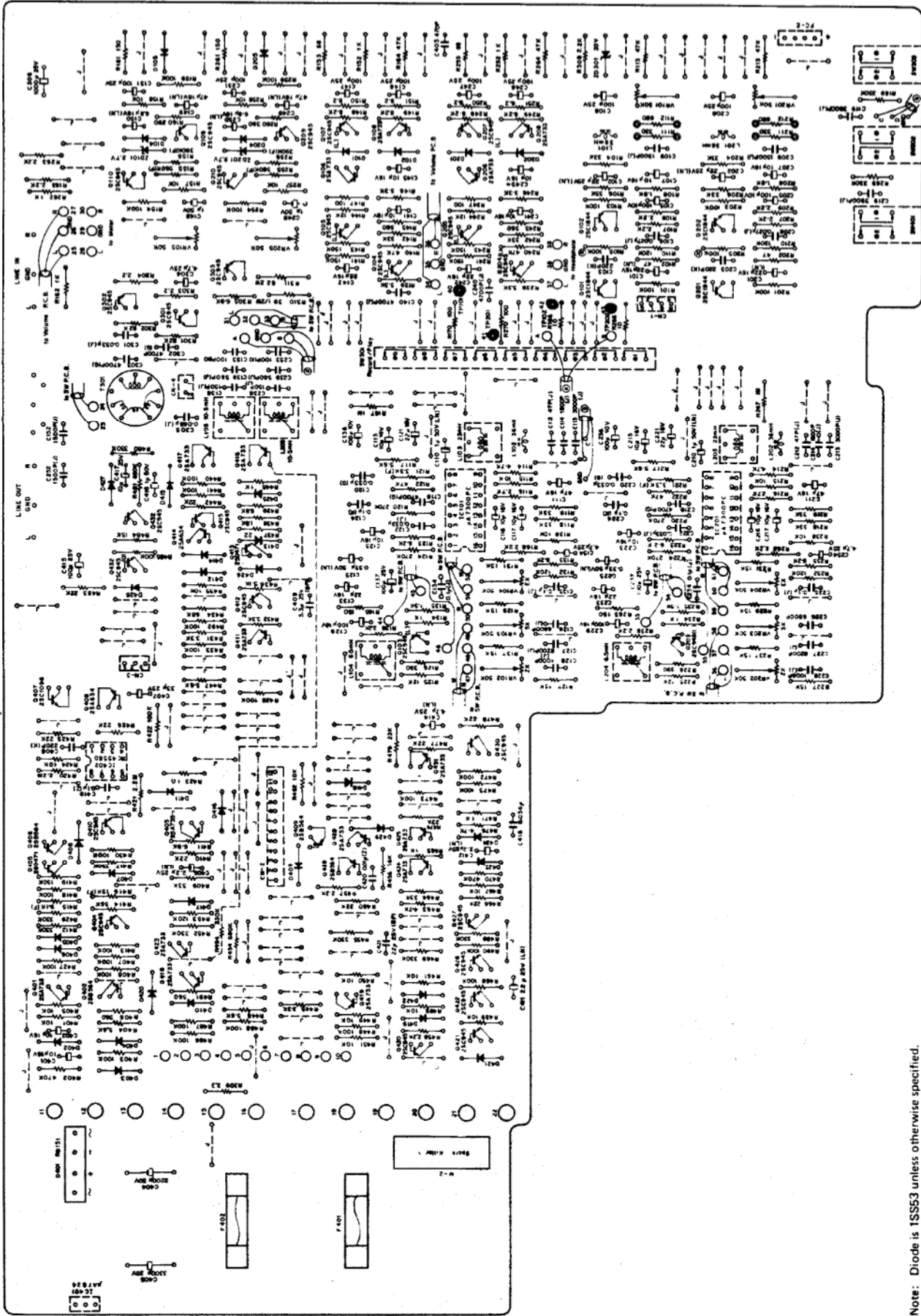

Fig. 8.8.2 Serial Nos: A304.501001 - A304.518704

Note: Diode is 1SS53 unless otherwise specified.

9.1. Synthesis

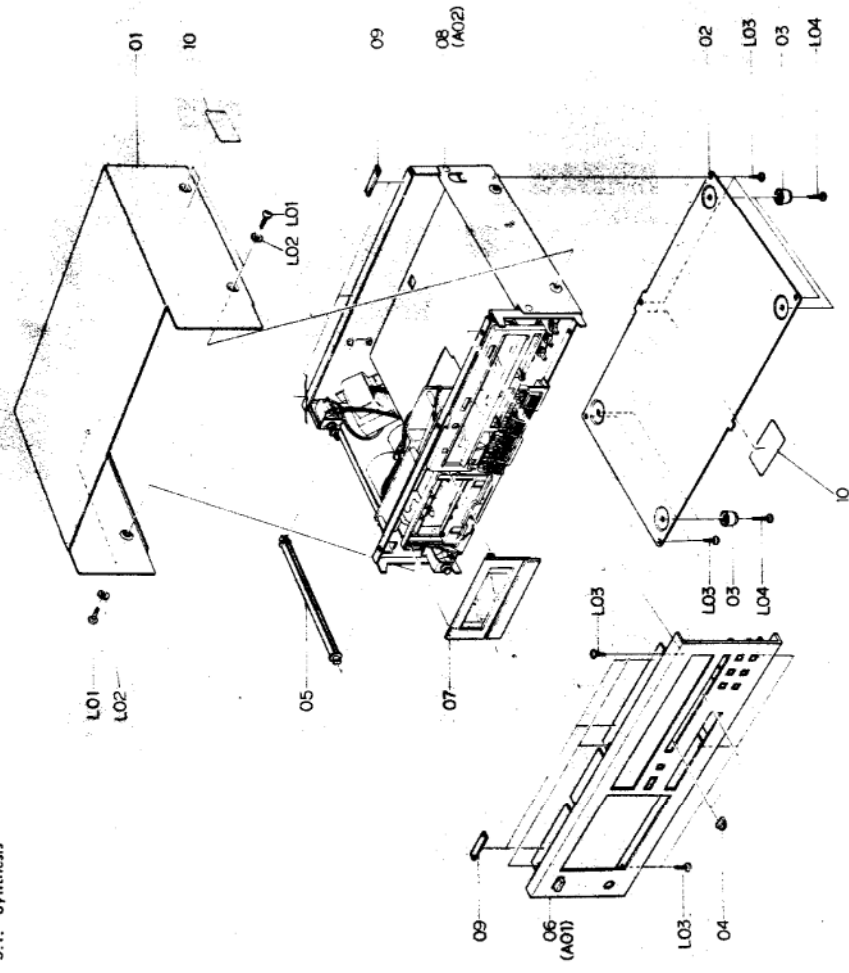

Fig. 9.1

Schematic Ref. No.	Part No.	Description	Qty	Schematic Ref. No.	Part No.	Description	Qty
01	0H03768A	Synthesis	1		JA03831A	Synthesis Mechanism Ass'y (Australia)	1
02	0H03769B	Top Cover Ass'y	1		JA03832A	Synthesis Mechanism Ass'y (UK)	1
03	0J03564A	Bottom Cover Ass'y	1		JA03833A	Synthesis Mechanism Ass'y (Others)	1
04	0H03794B	Leg T-H	4	09	0H03781A	Cushion	6
05	0J04066C	Volume Knob	2	10	0M04101A	Caution Label	2
06	HA03871A	Power Switch Joint Bar	1	L01	0E00858A	BT Screw M4x6 Philips Binding Head (Black Chromate)	4
07	HA03872A	Front Panel Ass'y	1	L02	0E00736A	Washer 4mm (Black Chromate)	4
08	JA03529A	Cassette Case Cover Ass'y (U.S.A. & Canada)	1	L03	0E00857A	BT Screw M3x6 Philips Binding Head	11
	JA03628A	Synthesis Mechanism Ass'y (Japan)	1	L04	0E00865A	BT Screw M3x10 Philips Binding Head	4
	JA03630A	Synthesis Mechanism Ass'y (220V Class 2)	1				

9.2. Front Panel Ass'y (A01)

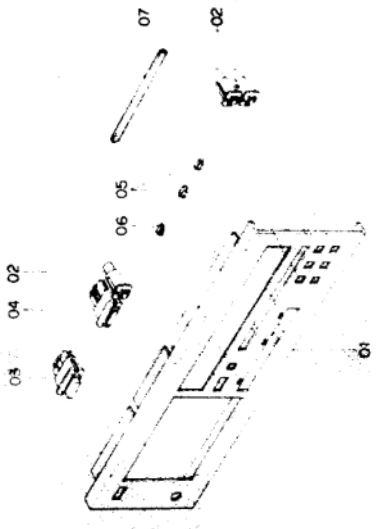

Fig. 9.2

9.3. Synthesis Mechanism Ass'y (A02)

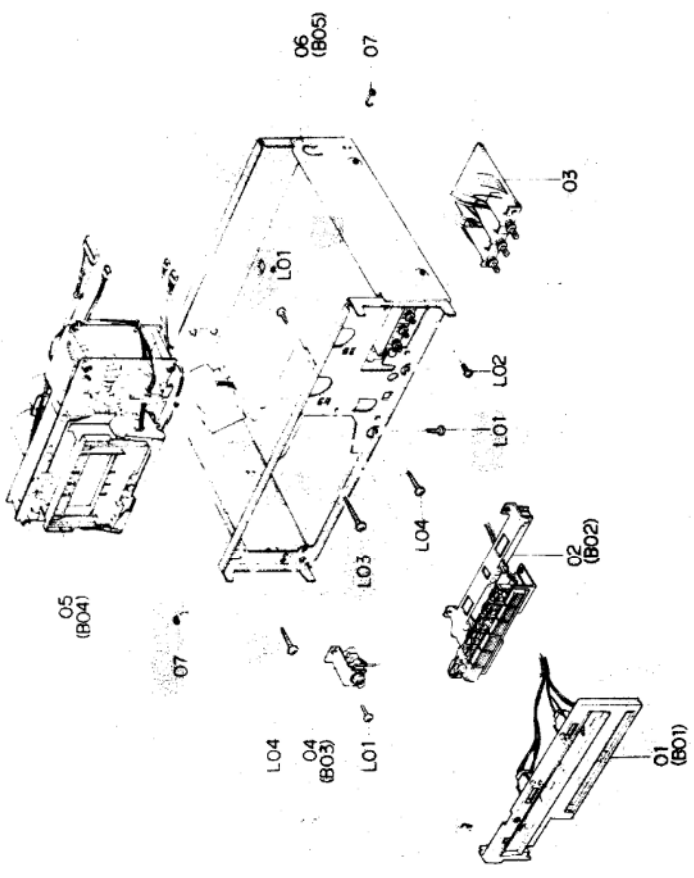

Fig. 9.3

9.4. Meter Escutcheon Ass'y (B01)

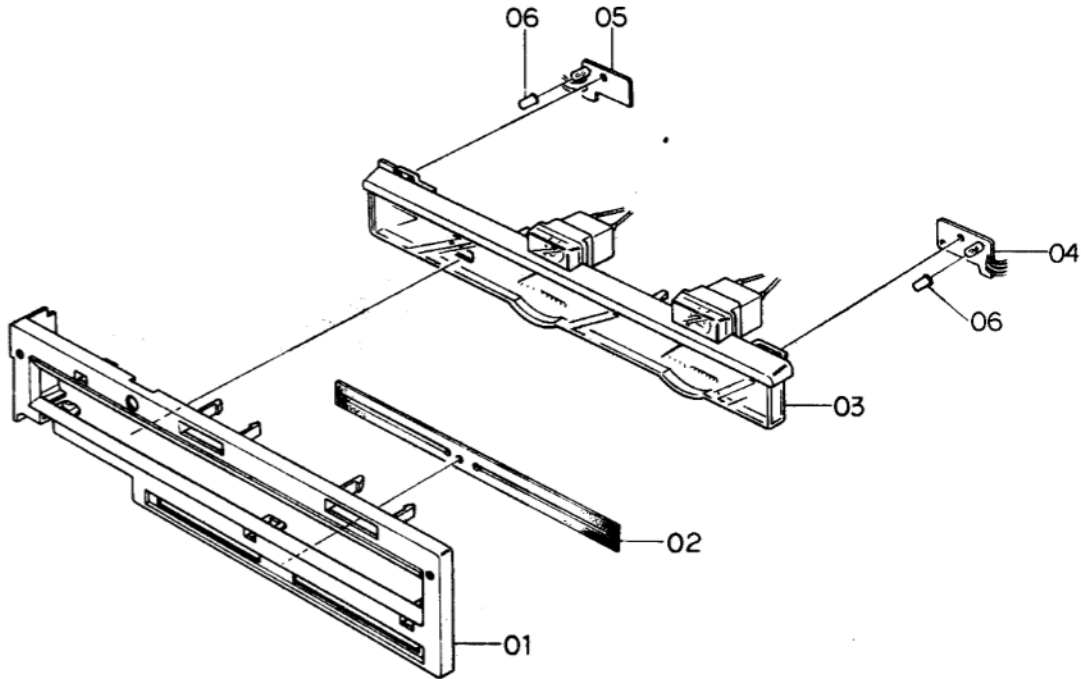

Fig. 9.4

Schematic Ref. No.	Part No.	Description	Q'ty	Schematic Ref. No.	Part No.	Description	Q'ty
<b>A01</b>	<b>HA03871A</b>	<b>Front Panel Ass'y</b>	<b>1</b>	<b>06</b>	<b>JA03611A</b>	Chassis Ass'y (U.S.A. & Canada)	1
01	0H03795B	Front Panel	1		JA03610A	Chassis Ass'y (Japan)	1
02	HA03873A	Push Button Ass'y C	7		JA03612A	Chassis Ass'y (220V Class 2)	1
03	HA03874A	Push Button Ass'y D	1		JA03613A	Chassis Ass'y (Australia)	1
04	HA03875A	Eject Button Ass'y	1		JA03614A	Chassis Ass'y (UK)	1
05	0H03744A	Green Lens	2		JA03615A	Chassis Ass'y (Others)	1
06	0H03745A	Orange Lens	1	<b>07</b>	<b>0B08515A</b>	Insu-Lock	<b>18</b>
07	0J04094A	Control Button Pad	1	<b>L01</b>	<b>0E00857A</b>	BT Screw M3x6 Philips Binding Head	<b>5</b>
-	0J04081A	Adhesive Tape 55x6	5	<b>L02</b>	<b>0E00502A</b>	Screw M3x5 Philips Pan Head	<b>2</b>
-	0J04082A	Adhesive Tape 30x6	2	<b>L03</b>	<b>0E00878A</b>	BT Screw M4x20 Philips Binding Head	<b>1</b>
<b>A02</b>	<b>JA03629A</b>	<b>Synthesis Mechanism Ass'y (U.S.A. &amp; Canada)</b>	<b>1</b>	<b>L04</b>	<b>0E00867A</b>	BT Screw M4x15 Philips Binding Head	<b>3</b>
	<b>JA03628A</b>	<b>Synthesis Mechanism Ass'y (Japan)</b>	<b>1</b>	<b>B01</b>	<b>HA03851A</b>	<b>Meter Escutcheon Ass'y</b>	<b>1</b>
	<b>JA03630A</b>	<b>Synthesis Mechanism Ass'y (220V Class 2)</b>	<b>1</b>	<b>01</b>	<b>0H03770B</b>	Meter Escutcheon	<b>1</b>
	<b>JA03631A</b>	<b>Synthesis Mechanism Ass'y (Australia)</b>	<b>1</b>	<b>02</b>	<b>0H03786A</b>	Volume Cover	<b>1</b>
	<b>JA03632A</b>	<b>Synthesis Mechanism Ass'y (UK)</b>	<b>1</b>	<b>03</b>	<b>BA04110B</b>	Meter Ass'y	<b>1</b>
	<b>JA03633A</b>	<b>Synthesis Mechanism Ass'y (Others)</b>	<b>1</b>	<b>04</b>	<b>BA04124A</b>	Lamp P.C.B. R Ass'y	<b>1</b>
<b>01</b>	<b>HA03851A</b>	<b>Meter Escutcheon Ass'y</b>	<b>1</b>	<b>05</b>	<b>BA04125A</b>	Lamp P.C.B. L Ass'y	<b>1</b>
<b>02</b>	<b>JA03627A</b>	<b>Control Switch Holder Ass'y</b>	<b>1</b>	<b>06</b>	<b>0H03785A</b>	Filter Cover	<b>2</b>
<b>03</b>	<b>BA04127A</b>	<b>Switch P.C.B. Ass'y</b>	<b>1</b>	-	<b>0H03771B</b>	Aluminum Seal	<b>1</b>
<b>04</b>	<b>JA03616A</b>	<b>Headphone Jack Ass'y</b>	<b>1</b>				
<b>05</b>	<b>CA08112A</b>	<b>Mechanism Ass'y 480</b>	<b>1</b>				

9.5. Control Switch Holder Ass'y (B02)

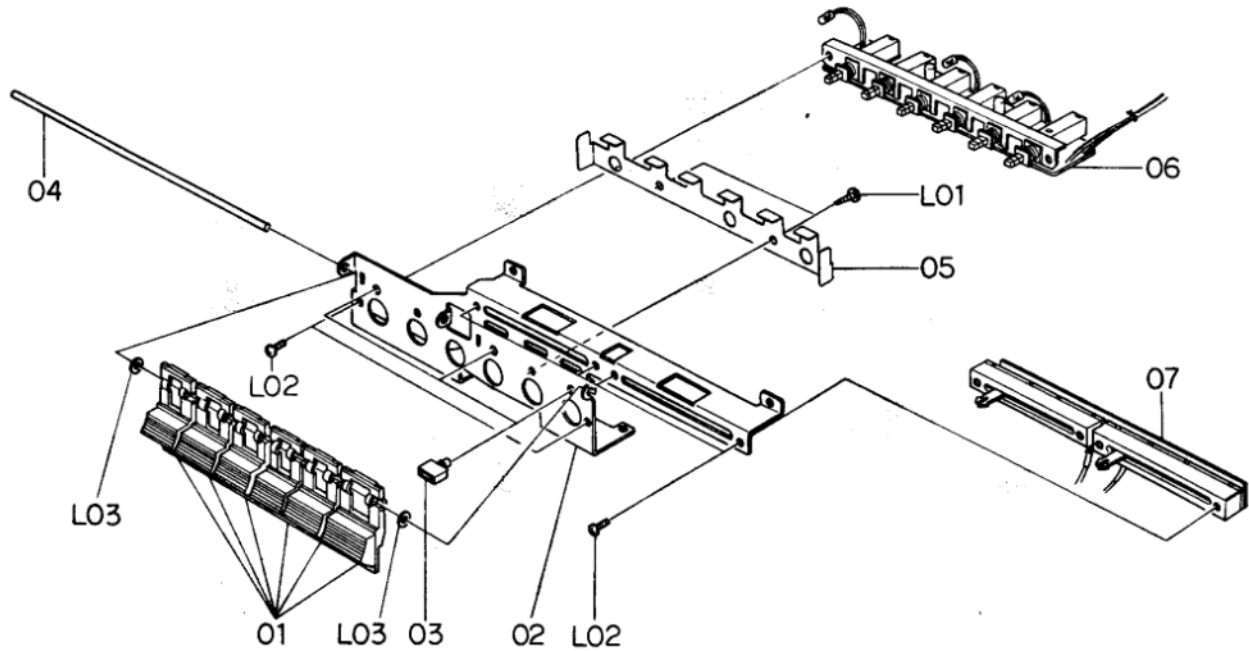

Fig. 9.5

9.6. Headphone Jack Ass'y (B03)

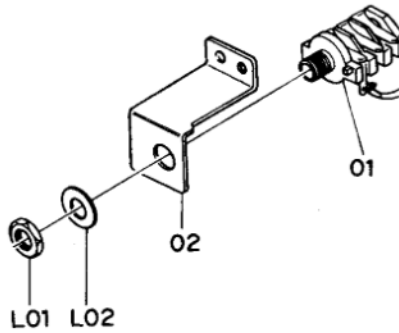

Fig. 9.6

Schematic Ref. No.	Part No.	Description	Q'ty	Schematic Ref. No.	Part No.	Description	Q'ty
<b>B02</b>	<b>JA03627A</b>	<b>Control Switch Holder Ass'y</b>	<b>1</b>	<b>B03</b>	<b>JA03616A</b>	<b>Headphone Jack Ass'y</b>	<b>1</b>
01	0H03793A	Control Button	6	01	0B08511A	Headphone Jack	1
02	0J04071C	Control Switch Holder	1	02	0J04070A	Headphone Jack Holder	1
03	0J04072B	Lamp Cover	3	L01	-	Jack Nut	(1)
04	0J04073A	Control Button Shaft	1	L02	-	Jack Washer	(1)
05	0J04074D	Control Button Spring	1				
06	BA04113A	Control Switch P.C.B. Ass'y	1				
07	BA04114A	Volume P.C.B. Ass'y	1				
L01	0E00857A	BT Screw M3x6 Philips Binding Head	2				
L02	0E00502A	Screw M3x5 Philips Pan Head	6				
L03	0E00117A	Washer 2mm	2				

Part No.	Description	Q'ty	Schematic Ref. No.	Part No.	Description	Q'ty
CA08112A	Mechanism Ass'y 480	1	L03	0E00833A	BT Screw M3x20 Phillips Pan Head	3
CA08109A	Flywheel Holder Ass'y	1	L04	0E00883A	BT Screw M3x18 Phillips Pan Head	5
0C08096C	Capstan Belt	1	L05	0E00835A	BT Screw M3x25 Phillips Pan Head	1
CA08113A	Supply Flywheel B Ass'y	1				
CA08107A	Take-up Flywheel B Ass'y	1				
0C08021B	Thrust Washer 3.1mm	1				
0C08020B	Thrust Washer 2.6mm	1				
0C08069C	Flange Thrust Cap	2				
0C08022B	Flange Thrust Spring	2				
CA08108A	Sub Mechanism Chassis Ass'y	1				
0C08098B	Counter Belt B	1				
0C08099B	Control Motor Belt	1				
CA08110A	Main Mechanism Chassis Ass'y	1				
0C08151A	Lid Arm Spring Tube	1				
0B08671B	12P-H Connector	1				
0B08672B	3P-H Connector	1				
0B08515A	Insu-Lock	8				
0M03902A	Motor Label 730	1				
0E00834A	BT Screw M3x30 Phillips Pan Head	1				
0E00178A	Washer 3mm	2				

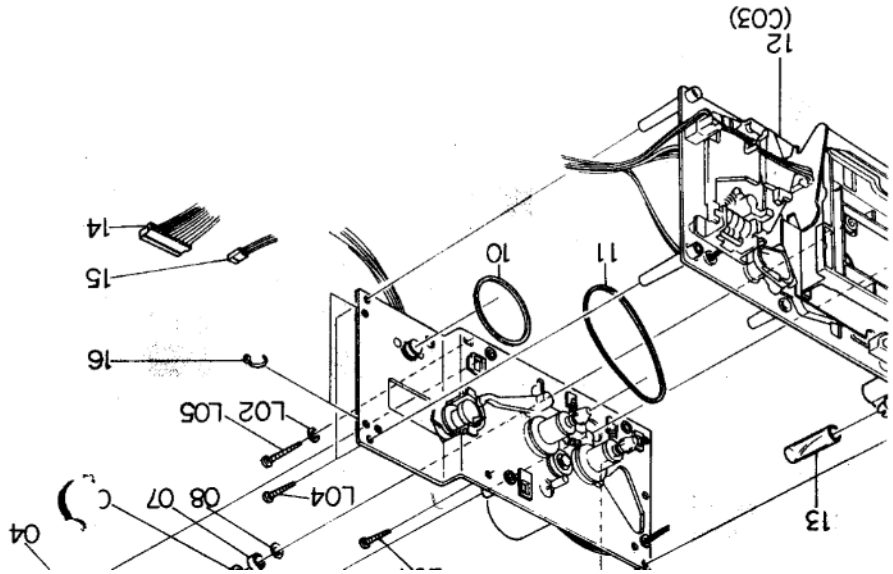

Fig. 9.7



Schematic Ref. No.	Part No.	Description	Q'ty	Schematic Ref. No.	Part No.	Description	Q'ty
B05	JA03611A	Chassis Ass'y (U.S.A. & Canada)	1		HA03855A	Rear Panel Ass'y (Japan)	1
	JA03610A	Chassis Ass'y (Japan)	1		HA03857A	Rear Panel Ass'y (220V Class 2)	1
	JA03612A	Chassis Ass'y (220V Class 2)	1				
	JA03613A	Chassis Ass'y (Australia)	1		HA03858A	Rear Panel Ass'y (Australia)	1
	JA03614A	Chassis Ass'y (UK)	1		HA03859A	Rear Panel Ass'y (UK)	1
	JA03615A	Chassis Ass'y (Others) Serial No.: A304.518705 -	1		HA03860A	Rear Panel Ass'y (Others)	1
				06	0C08240A	Contact Wire	1
				*07	0M03700A	Earth Mark Label	1
01	0J04068B	Front Chassis	1	L01	0E00502A	Screw M3x5 Philips Pan Head	2
02	0J04069B	Side Chassis	2	*L02	0E00857A	BT Screw M3x6 Philips Binding Head	11
03	0B08720A	Plastic Rivet	3				
04	BA04130B	Main P.C.B. Ass'y (U.S.A. & Canada)	1	L03	0E00860A	BT Screw M3x6 Philips Binding Head (Black Chromate)	1
	BA04112B	Main P.C.B. Ass'y (Japan)	1	L04	0E00624A	Screw M3x10 Philips Pan Head (2A)	1
	BA04131B	Main P.C.B. Ass'y (220V Class 2)	1				
	BA04132B	Main P.C.B. Ass'y (UK & Australia)	1	L05	0E00178A	Washer 3mm	1
	BA04133B	Main P.C.B. Ass'y (Others)	1	L06	0E00507A	Nut Hex. M3	2
05	HA03856A	Rear Panel Ass'y (U.S.A. & Canada)	1	*L07	0E00037A	Earth Lug B-5	1
						*: Depends on the versions.	
	HA03855A	Rear Panel Ass'y (Japan)	1	C01	CA08109A	Flywheel Holder Ass'y	1
	HA03857A	Rear Panel Ass'y (220V Class 2)	1				
	HA03858A	Rear Panel Ass'y (Australia)	1	01	0C080131	Flywheel Holder	1
	HA03859A	Rear Panel Ass'y (UK)	1	02	BA04126A	Control P.C.B. Ass'y	1
	HA03860A	Rear Panel Ass'y (Others)	1	03	0C08219A	Capstan Motor	1
06	0C08240A	Contact Wire	1	04	0C08212B	Capstan Motor Pulley	1
* 07	0M03700A	Earth Mark Label	1	05	0M04077A	Motor Seal	1
L01	0E00502A	Screw M3x5 Philips Pan Head	2	L01	0E00226A	Screw M2.6x4 Philips Pan Head	3
*L02	0E00857A	BT Screw M3x6 Philips Binding Head	11	L02	0E00843A	BT Screw M3x5 Philips Pan Head	1
L03	0E00860A	BT Screw M3x6 Philips Binding Head (Black Chromate)	1				
L04	0E00624A	Screw M3x10 Philips Pan Head (2A)	1	L03	0C08068C	Thrust Screw	2
L05	0E00178A	Washer 3mm	1	L04	0C03857A	Lock Nut	2
L06	0E00507A	Nut Hex. M3	2				
*L07	0E00037A	Earth Lug B-5	1				
						*: Depends on the versions.	
B05	JA03611A	Chassis Ass'y (U.S.A. & Canada)	1				
	JA03610A	Chassis Ass'y (Japan)	1				
	JA03612A	Chassis Ass'y (220V Class 2)	1				
	JA03613A	Chassis Ass'y (Australia)	1				
	JA03614A	Chassis Ass'y (UK)	1				
	JA03615A	Chassis Ass'y (Others) Serial Nos.: A304.501001 - A304.518704	1				
01	0J04068B	Front Chassis	1				
02	0J04069B	Side Chassis	2				
03	0B08539A	Plastic Rivet	3				
04	BA04130A	Main P.C.B. Ass'y (U.S.A. & Canada)	1				
	BA04112A	Main P.C.B. Ass'y (Japan)	1				
	BA04131A	Main P.C.B. Ass'y (220V Class 2)	1				
	BA04132A	Main P.C.B. Ass'y (UK & Australia)	1				
	BA04133A	Main P.C.B. Ass'y (Others)	1				
05	HA03856A	Rear Panel Ass'y (U.S.A. & Canada)	1				

9.8. Chassis Ass'y (B05)

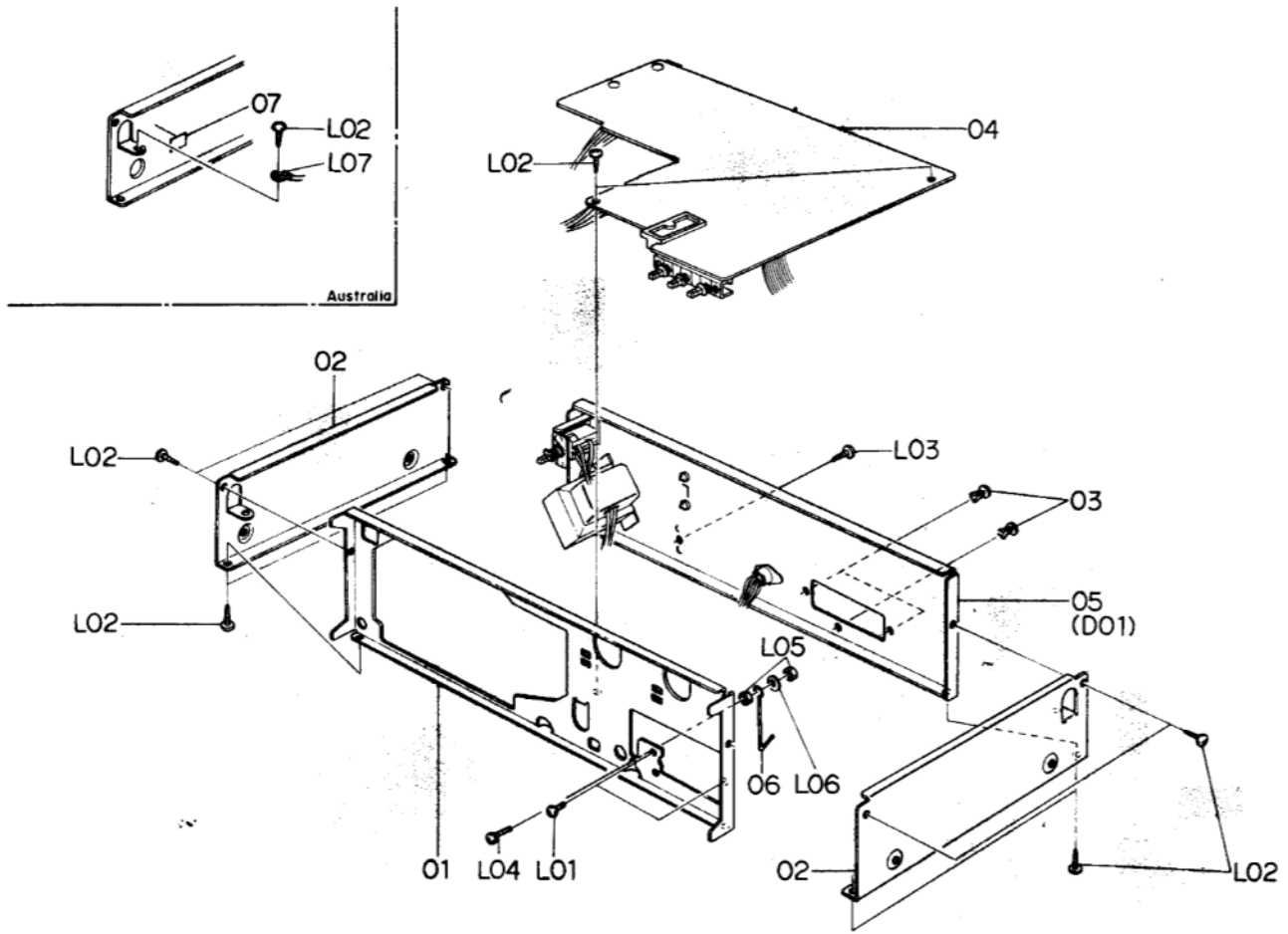

Fig. 9.8

9.9. Flywheel Holder Ass'y (C01)

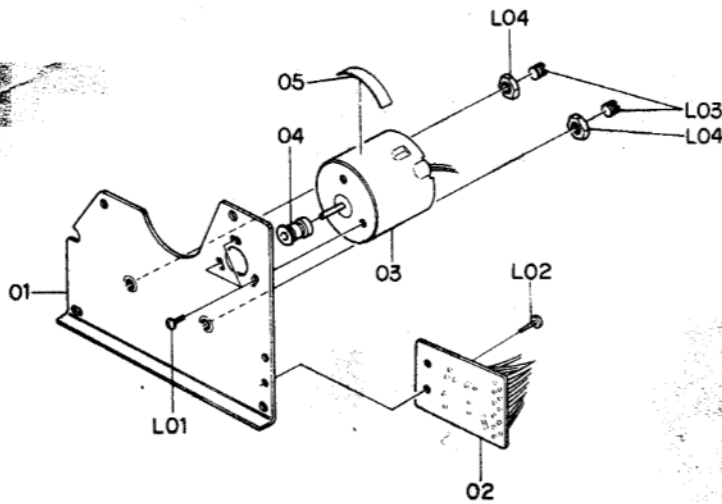

Fig. 9.9

9.10. Sub Mechanism Chassis Ass'y (C02)

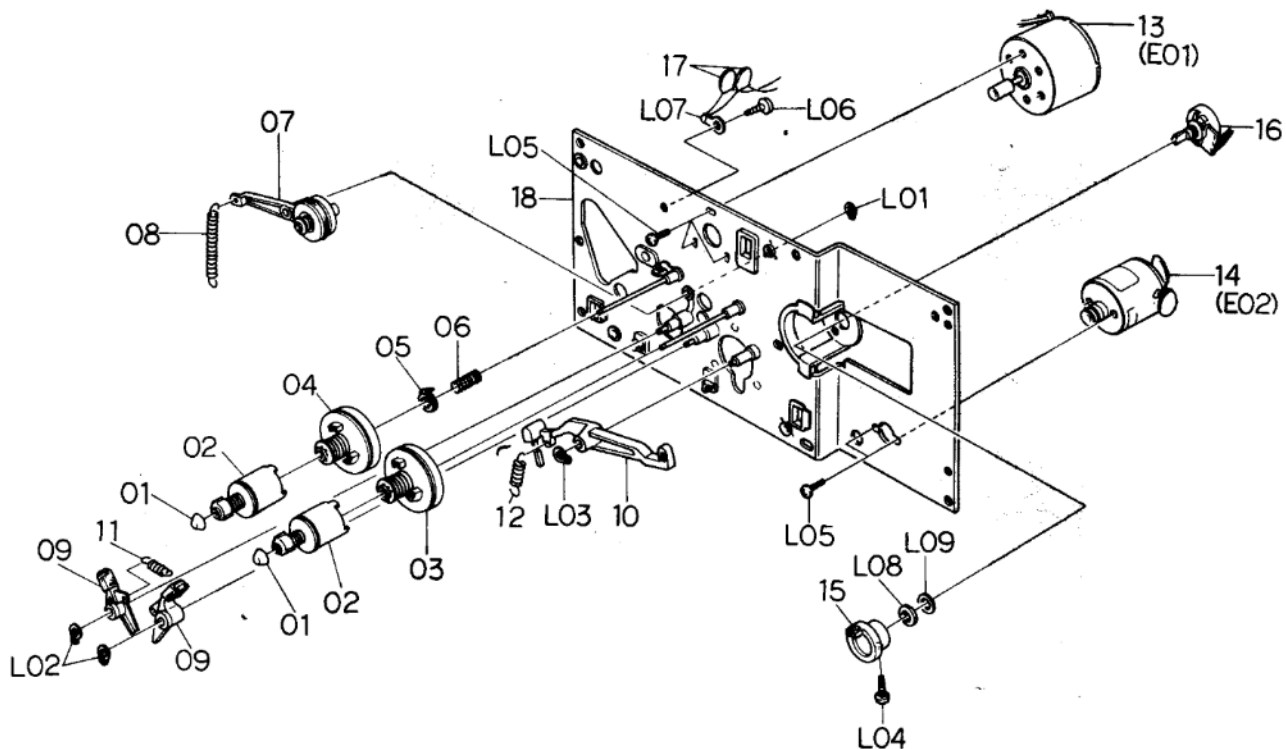

Fig. 9.10

Schematic Ref. No.	Part No.	Description	Q'ty	Schematic Ref. No.	Part No.	Description	Q'ty
C02	CA08108A	Sub Mechanism Chassis Ass'y	1	L06	0E00843A	BT Screw M2.6x4 Philips Pan Head	1
01	0C08039B	Reel Hub Head	2	L07	0E00037A	Earth Lug B-5	1
02	CA08038B	Reel Hub B Ass'y	2	L08	-	Volume Nut	(1)
03	CA08037A	Reel Hub Take-up Ass'y	1	L09	-	Volume Washer	(1)
04	CA08064A	Reel Hub Supply Ass'y	1				
05	CA08039A	Back Tension Ass'y	1				
06	0C08178A	Back Tension Spring	1				
07	CA08040A	Idler Ass'y	1				
08	0C08127B	Idler Arm Spring	1				
09	CA08042A	Brake Arm Ass'y	2				
10	0C08030C	Brake Drive Arm	1				
11	0C08029A	Brake Arm Spring	1				
12	0C08128A	Brake Drive Arm Spring	1				
13	CA08117B	Reel Motor Ass'y	1				
14	CA08124A	Control Motor Ass'y	1				
15	0C08053B	Volume Coupler	1				
16	0B07240A	Volume Control 10 KΩ (B)	1				
17	0B09091A	Ceramic Capacitor 0.01μ 50V	2				
18	CA08041A	Sub Chassis Ass'y	1				
L01	0E00842A	Stopper Ring 2mm	1				
L02	0E00837A	Stopper Ring 3mm	2				
L03	0E00838A	Stopper Ring 4mm	1				
L04	0E00859A	BT Screw M2.6x6 Philips Binding Head	1				
L05	0E00226A	Screw M2.6x4 Philips Pan Head	5				

Schematic Ref. No.	Part No.	Description	Q'ty	Schematic Ref. No.	Part No.	Description	Q'ty
C03	CA08110A	Main Mechanism Chassis Ass'y	1	L08	0E00876A	BT Screw M2.6x8 Philips Pan Head	11
01	CA08141A	Cassette Case Holder L Ass'y	1	L09	0C08060B	Height Adjustment Nut	2
02	CA08022A	Cassette Case Holder R Ass'y	1	L10	0E00142A	Washer 2.6mm	2
03	CA08111A	Cassette Case Ass'y	1	L11	0E00879A	BT Screw M2x15 Philips Pan Head	1
04	0C08019I	Cover Plate	1	L12	0E00838A	Stopper Ring 4mm	3
05	0M03977A	Cassette Viewer Label	1	L13	0E00846A	BT Screw M3x8 Philips Pan Head	3
06	CA08120A	Head Mount Base Ass'y	1	L14	0E00895A	Earth Lug 3mm	2
07	0C08121A	Supply Pressure Roller Spring	2				
08	CA08053B	Supply Pressure Roller Ass'y	1				
09	0C08122B	Supply Pressure Roller Thrust Spring	1				
10	CA08079B	Take-up Pressure Roller Ass'y	1				
11	0C08183B	Take-up Pressure Roller Thrust Spring	1				
12	0C08182A	Pressure Roller Drive Bar	1				
13	CA08121A	Head Base Ass'y C	1				
14	0C08086B	Head Base Roller	3				
15	0C08050B	Record Sensor	1				
16	0C08051E	Cassette Hold Arm	1				
17	0C08120A	Cassette Hold Arm Spring	1				
18	CA08027A	Head Base Drive Arm Ass'y	1				
19	0C08143C	Head Base Drive Arm Spring	1				
20	CA08025A	Record Arm Ass'y	1				
21	0C08038D	Record Trigger	1				
22	0C08112A	Flip-Flop Spring	1				
23	CA08026A	Pressure Roller Drive Arm Ass'y	1				
24	0C08071D	Counter Reset Arm	1				
25	0C08124B	Eject Linkage Wire	1				
26	0C08057D	Eject Arm	1				
27	0C08078B	Arm Shaft	1				
28	CA08119A	Auto Shut-off Ass'y	1				
29	CA08020A	Counter Ass'y	1				
30	0C08097B	Counter Belt A	1				
31	0C08067C	Eject Stopper	1				
32	0C08134C	Eject Stopper Spring	1				
33	0C08119A	Record Protector	1				
34	0C08194C	Damper Lock Arm	1				
35	0C08153A	Damper Arm Spring Tube	1				
36	CA08030A	Pneumatic Damper Ass'y	1				
37	CA08023A	Supply Capstan Flange Ass'y	1				
38	CA08024A	Take-up Capstan Flange Ass'y	1				
39	0C08186A	Cam Drive Gear	1				
40	0C08029H	Control Cam	1				
41	0C08152A	Counter-Load Arm Spring Tube	1				
42	0C08117A	Counter-Load Arm Spring	1				
43	CA08028A	Counter-Load Arm Ass'y	1				
44	0C08123B	Record Switch Linkage Wire	1				
45	0C08037E	Record Arm B	1				
46	0C08116A	Record Arm Spring	2				
47	CA08072A	Main Chassis Ass'y	1				
48	0C08225A	Shield Plate	1				
L01	0E00837A	Stopper Ring 3mm	13				
L02	0E00832A	BT Screw M3x14 Philips Pan Head	2				
L03	0E00834A	BT Screw M3x30 Philips Pan Head	2				
L04	0E00831A	BT Screw M3x10 Philips Pan Head	4				
L05	0E00254A	Washer 3.1mm Plastics	2				
L06	0E00222A	E-Ring 2mm	2				
L07	0E00839A	Stopper Ring 2.5mm	2				

9.11. Main Mechanism Chassis Ass'y (C03)

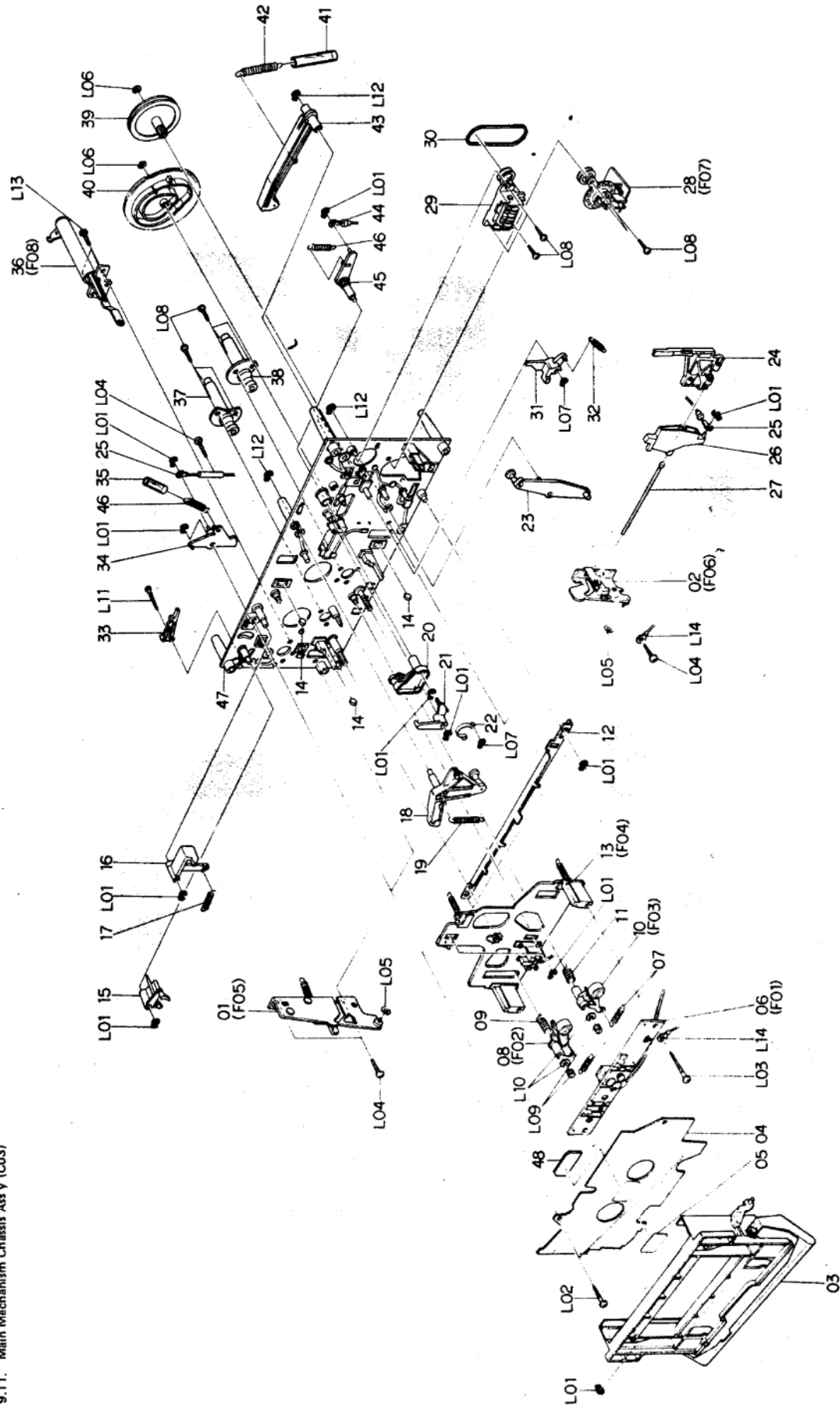

Fig. 9.11

9.12. Rear Panel Ass'y (D01)

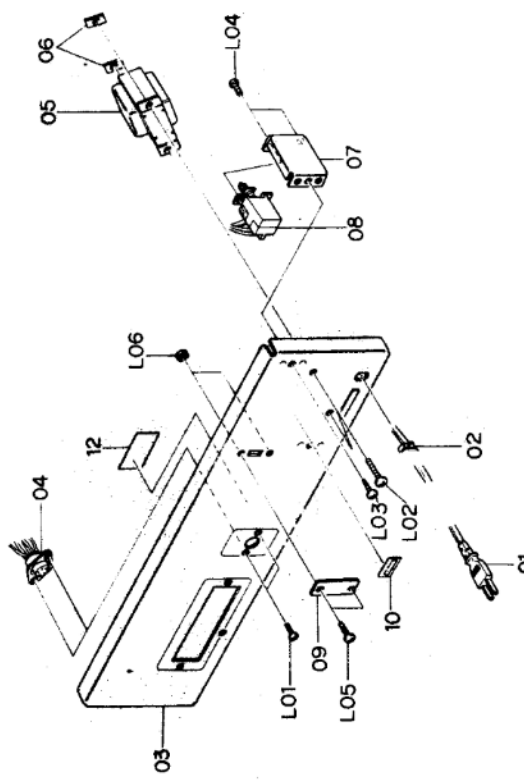
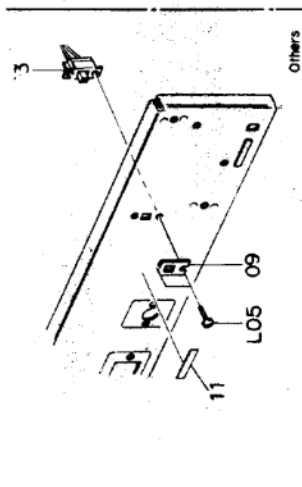

Fig. 9.12

Schematic Ref. No.	Part No.	Description	Qty	Schematic Ref. No.	Part No.	Description	Qty
D01	HA03856A	Rear Panel Ass'y (U.S.A. & Canada)	1	L06	0E00807A	Nut Hex. M3	2
	HA03855A	Rear Panel Ass'y (Japan)	1		0J03644A	Chobert Rivet	2
	HA03857A	Rear Panel Ass'y (220V Class 2)	1		*: Depends on the versions.		
	HA03858A	Rear Panel Ass'y (Australia)	1				
	HA03859A	Rear Panel Ass'y (UK)	1				
01	HA03860A	Rear Panel Ass'y (Others)	1	E01	CA08117B	Reel Motor Ass'y	1
	0B08533A	Power Cord (U.S.A., Canada & Others)	1		0C08218A	Reel Motor	1
	0B08219B	Power Cord (Japan)	1		0C08063F	Reel Motor Pulley	1
	0B08093U	Power Cord (220V Class 2)	1		CA08124A	Control Motor Ass'y	1
	0B08666A	Power Cord (Australia)	1		0C08137A	Control Motor	1
02	0B08348A	Power Cord (UK)	1	0C08064A	Control Motor Pulley	1	
	0B08037U	Cord Bushing (U.S.A., Canada, Japan, 220V Class 2 & Others)	1	0B09292A	Ceramic Capacitor 0.1µ 50V	2	
	0B08719A	Cord Bushing (Australia)	1	0M03965A	Control Motor Label	1	
	0B08351A	Cord Bushing 4K-4 (UK)	1	0M03988A	Motor Seal B	1	
	0H03790	Rear Panel	1	CA08120A	Head Mount Base Ass'y	1	
03	0B08687A	6P DIN Socket	1	0C08029C	Head Height Adjustment Gear	1	
	0B06623A	Power Transformer (U.S.A. & Canada)	1	0C08027E	Head Height Adjustment Screw	2	
	0B06622A	Power Transformer (Japan)	1	0C08026D	Azimuth Alignment Screw	1	
	0B06624A	Power Transformer (220V Class 2, UK & Australia)	1	0C08161B	Spring Stopper	1	
	0B06625A	Power Transformer (Others)	1	0C08131C	Head Plate Spring	1	
06	0C01162B	Bolt Reception Plate	2	CA08083C	Head Mount Base Sub Ass'y	1	
	0J04076A	Power Switch Holder	1	CA08144A	RP-9E Record/Playback Head Ass'y	1	
	0B07299A	Power Switch (U.S.A. & Canada)	1	CA08053B	Supply Pressure Roller Ass'y	1	
	0B07301A	Power Switch (Japan)	1	0C08164G	Pressure Roller	1	
	0B07252A	Power Switch (220V Class 2, Australia, UK & Others)	1	0C08189B	Supply Tape Guide	1	
09	0J03663C	Switch Cover (U.S.A., Canada, Japan, 220V Class 2, UK & Australia)	1	CA08061A	Supply Pressure Roller Arm Ass'y	1	
	0M03946A	Voltage Selector Lock Plate C (Others)	1	0E00042A	E-Ring 1.5mm	1	
	0M03551B	Pass Label	1	0C08002A	Washer 2mm	2	
	0M03794A	Voltage Label 100V (Japan)	1	0E00788A	BT Screw M2x8 Philips Pan Head	1	
	0M03796A	Voltage Label 220V (220V Class 2)	1	CA08079B	Take-up Pressure Roller Ass'y	1	
10	0M03797A	Voltage Label 240V (UK & Australia)	1	F03	CA08079B	Take-up Pressure Roller Ass'y	1
	0M03551B	Pass Label	1		Serial Nos. A304.516074 -		
	0M03794A	Voltage Label 100V (Japan)	1		0C08164G	Pressure Roller	1
	0M03796A	Voltage Label 220V (220V Class 2)	1		0C08181C	Take-up Tape Guide	1
	0M03797A	Voltage Label 240V (UK & Australia)	1		CA08073B	Take-up Pressure Roller Arm Ass'y	1
*12	0M03956A	Voltage Label 120V/220-240V (Others)	1	L01	0E00042A	E-Ring 1.5mm	1
	0M04097B	Fuse Caution Label (U.S.A. & Canada)	1		0C08024A	Washer 2mm	2
	0B07092U	Voltage Selector (Others)	1		0E00788A	BT Screw M2x8 Philips Pan Head	1
	0M03848B	Power Cord Label (UK)	1		CA08079A	Take-up Pressure Roller Ass'y	1
	0F01071A	Free-up Belt	1		Serial Nos. A304.501001 - A304.516073		
*13	0M04055A	SDNF Label (220V Class 2)	1	01	0C08164G	Pressure Roller	1
	0M03865A	SEV Label (220V Class 2)	1		0C08181B	Take-up Tape Guide	1
	0M04069B	Serial Number Plate	1		CA08073B	Take-up Pressure Roller Arm Ass'y	1
	0M03798A	Nakamichi Label (Japan)	1		0E00042A	E-Ring 1.5mm	1
	0E00714A	Screw M2.6x6 Philips Binding Head (Bronze)	2		0C08024A	Washer 2mm	2
L01	0E00756A	Screw M4x8 Philips Binding Head (Bronze)	2	L02	0C08024A	Washer 2mm	2
L02	0E00860A	BT Screw M3x6 Philips Binding Head (Black Chromate)	1	L03	0E00788A	BT Screw M2x8 Philips Pan Head	1
L03	0E00802A	Screw M3x5 Philips Pan Head	1	F03	CA08079A	Take-up Pressure Roller Ass'y	1
L04	0E00893A	Screw M3x6 Philips Binding Head (Bronze)	2		Serial Nos. A304.501001 - A304.516073		
L06	0E00893A	Screw M3x6 Philips Binding Head (Bronze)	2		0C08164G	Pressure Roller	1

9.13. Reel Motor Ass'y (E01)

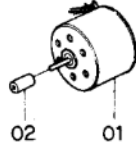

Fig. 9.13

9.14. Control Motor Ass'y (E02)

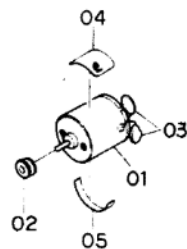

Fig. 9.14

9.15. Head Mount Base Ass'y (F01)

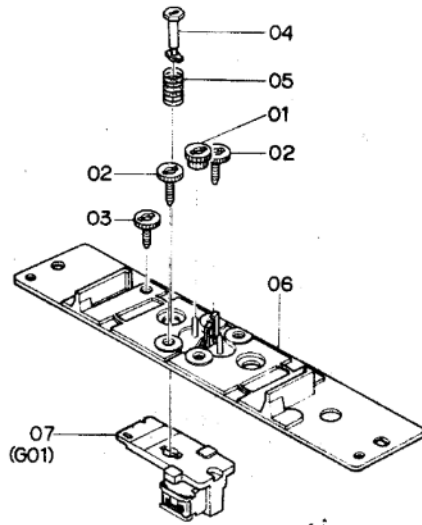

Fig. 9.15

9.16. Supply Pressure Roller Ass'y (F02)

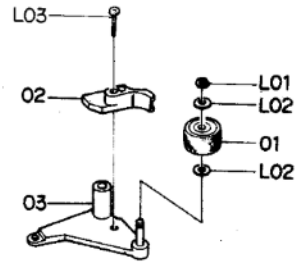

Fig. 9.16

9.17. Take-up Pressure Roller Ass'y (F03)

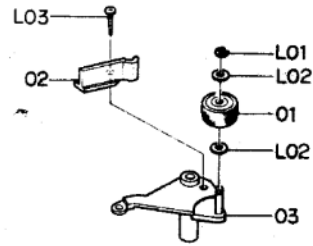

Fig. 9.17

9.18. Head Base Ass'y C (F04)

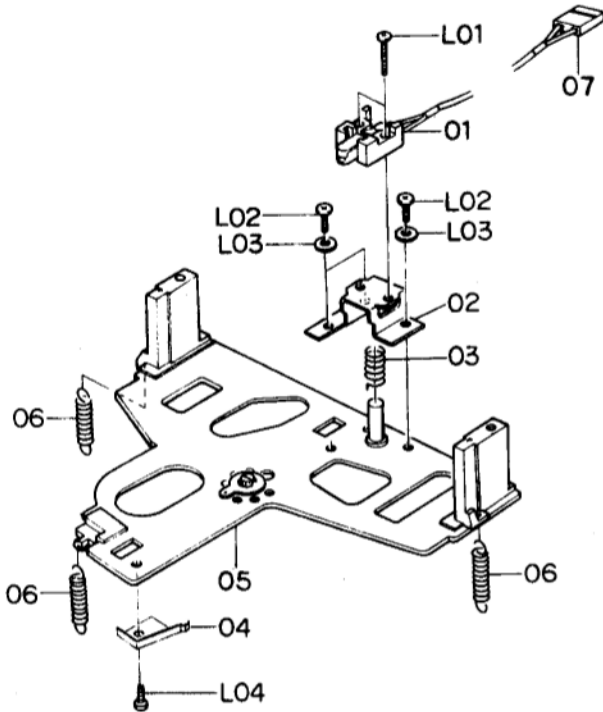

Fig. 9.18

9.19. Cassette Case Holder L Ass'y (F05)

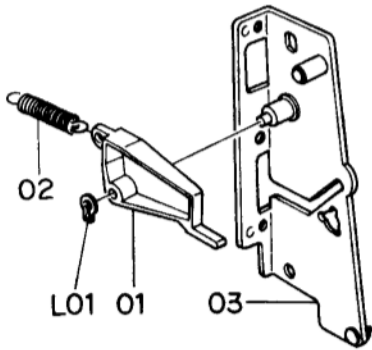

Fig. 9.19

9.20. Cassette Case Holder R Ass'y (F06)

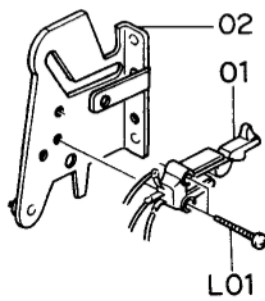

Fig. 9.20

9.21. Auto Shut-off Ass'y (F07)

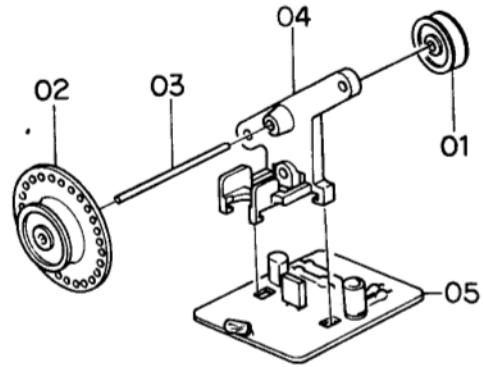

Fig. 9.21

9.22. Pneumatic Damper Ass'y (F08)

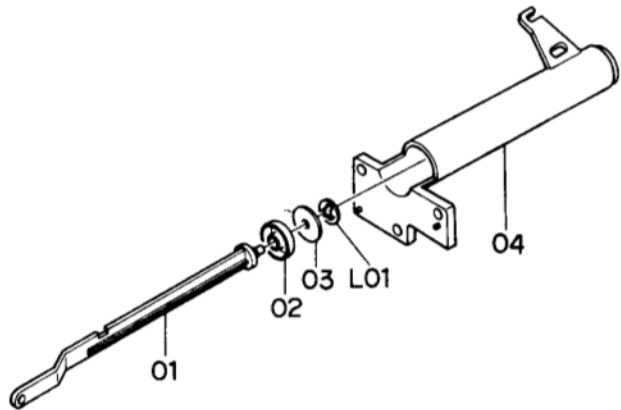

Fig. 9.22

9.23. RP-9E Record/Playback Head Ass'y (G01)

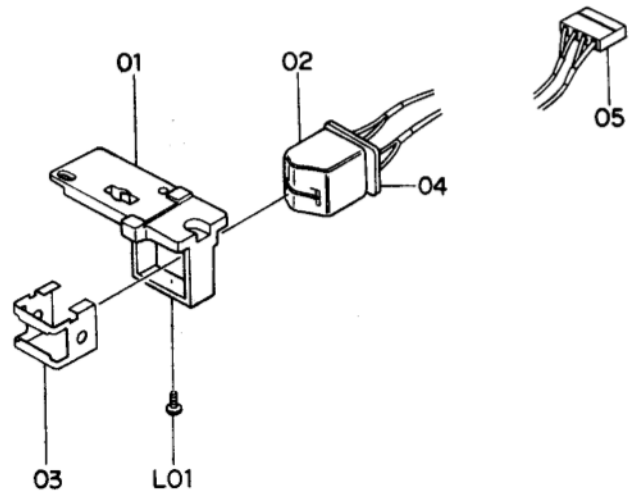

Fig. 9.23



Schematic Ref. No.	Part No.	Description	Q'ty
<b>F04</b>	<b>CA08121A</b>	<b>Head Base Ass'y C</b>	<b>1</b>
01	GA02017A	E-8L Erase Head	1
02	0C08158D	EH Hold Plate	1
03	0C08166A	EH Hold Plate Spring	1
04	0C08174C	Cassette Hold Spring	1
05	CA08003P	Head Base Ass'y	1
06	0C08175A	Head Base L Spring	3
07	0B08679D	2P-H Connector	1
L01	0E00889A	Screw M1.7x8 Philips Pan Head	2
L02	0E00909A	Screw M2x6 Philips Pan Head	3
L03	0E00117A	Washer 2mm	3
L04	0E00853A	BT Screw M2x3 Philips Pan Head	1
<b>F05</b>	<b>CA08141A</b>	<b>Cassette Case Holder L Ass'y</b>	<b>1</b>
01	0C08073C	Lid Arm A	1
02	0C08114A	Lid Arm Spring	1
03	CA08090F	Cassette Case Holder L Sub Ass'y	1
L01	0E00837A	Stopper Ring 3mm	1
<b>F06</b>	<b>CA08022A</b>	<b>Cassette Case Holder R Ass'y</b>	<b>1</b>
01	0C08133A	Eject Sensor	1
02	CA08044A	Cassette Case Holder R Sub Ass'y	1
L01	0E00840A	BT Screw M2x8 Philips Pan Head	2
<b>F07</b>	<b>CA08119A</b>	<b>Auto Shut-off Ass'y</b>	<b>1</b>
01	0C08047A	Shut-off Pulley A	1
02	0C08206B	Shut-off Pulley B	1
03	0C08088B	Shut-off Pulley Shaft	1
04	0C08207B	Shut-off Pulley Holder	1
05	BA04127A	Shut-off P.C.B. Ass'y	1
<b>F08</b>	<b>CA08030A</b>	<b>Pneumatic Damper Ass'y</b>	<b>1</b>
01	0C08058C	Damper Piston	1
02	0C08102B	Damper Ring	1
03	0C08010C	Damper Plate	1
04	0C08059D	Sylinder	1
L01	0E00874A	Stopper Ring CS 2mm	1
<b>G01</b>	<b>CA08144A</b>	<b>RP-9E Record/Playback Head Ass'y</b>	<b>1</b>
01	0C08217A	Head Plate	1
02	0G01294A	RP-9E Record/Playback Head	1
03	0C08216B	Pad Lifter 9E	1
04	0B07857A	Head Terminal P.C.B.	1
05	0B08678C	4P-H Connector	1
L01	0E00887A	Screw M1.7x4 Philips Pan Head	1

10. OVERALL TIMING CHART

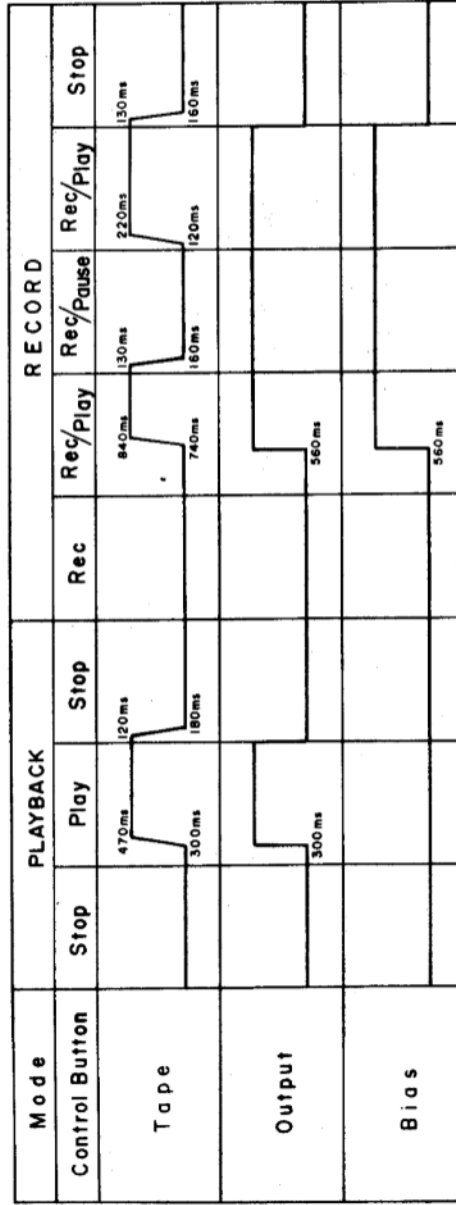

Fig. 10

# 11. EQ. AMP. FREQUENCY RESPONSE

## 11.1. Playback Frequency Response

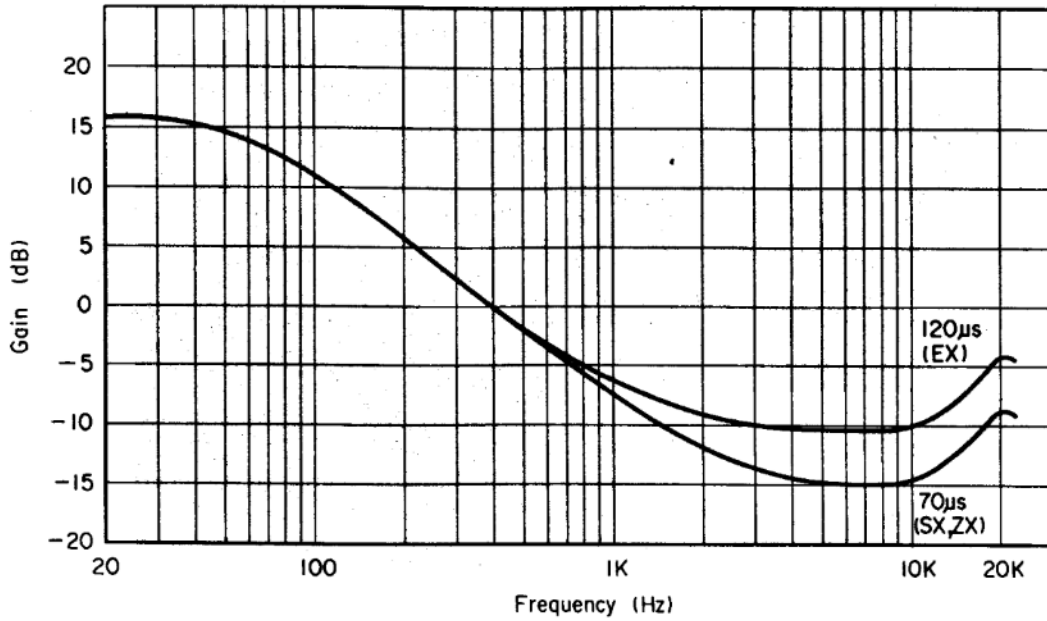

Fig. 11.1

## 11.2. Record Current Frequency Response

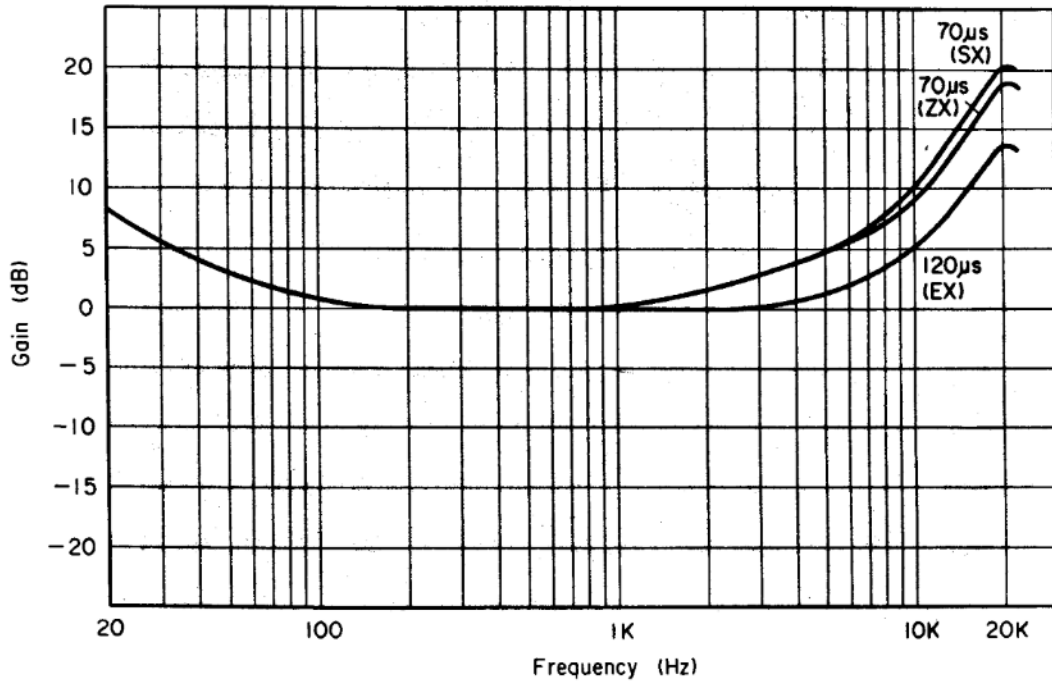

Fig. 11.2

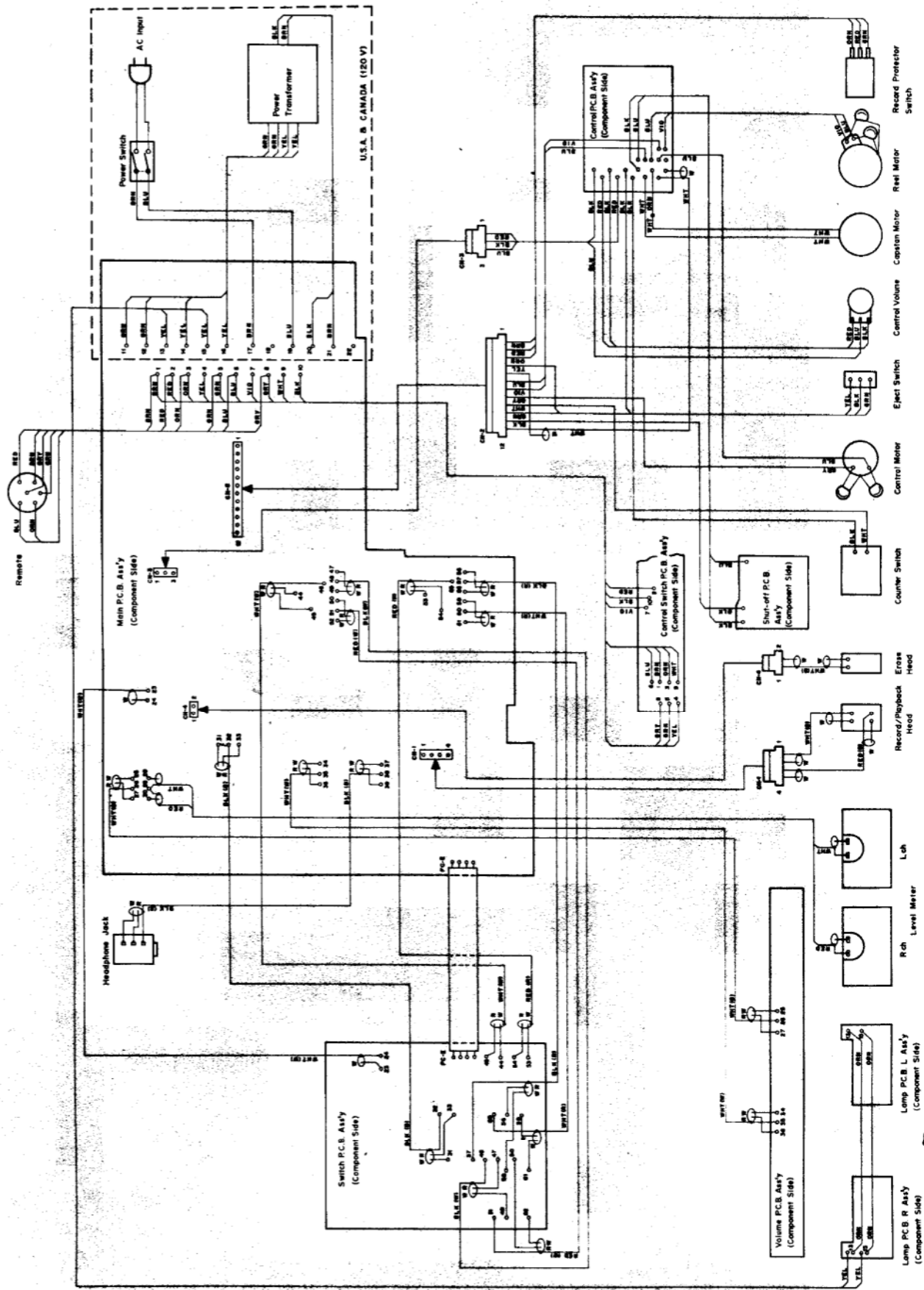

Fig. 12.2

13. BLOCK DIAGRAMS

13.1. Amplifier

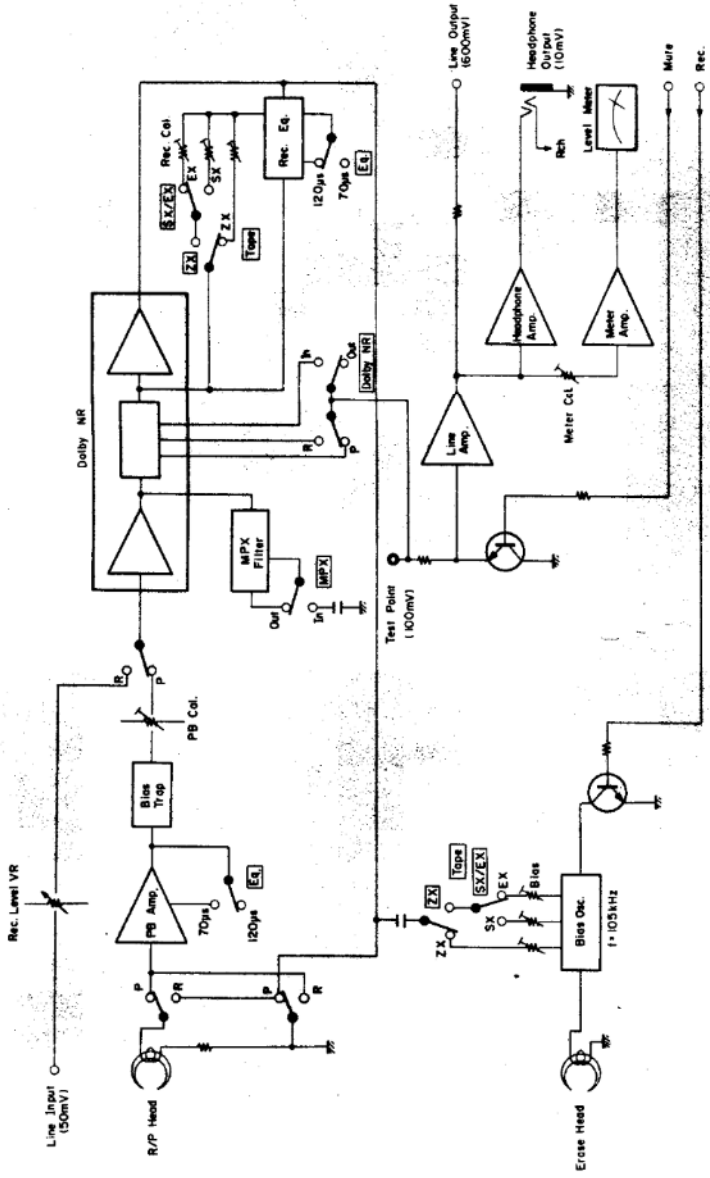

Fig. 13.1

13.2. Mechanism Control

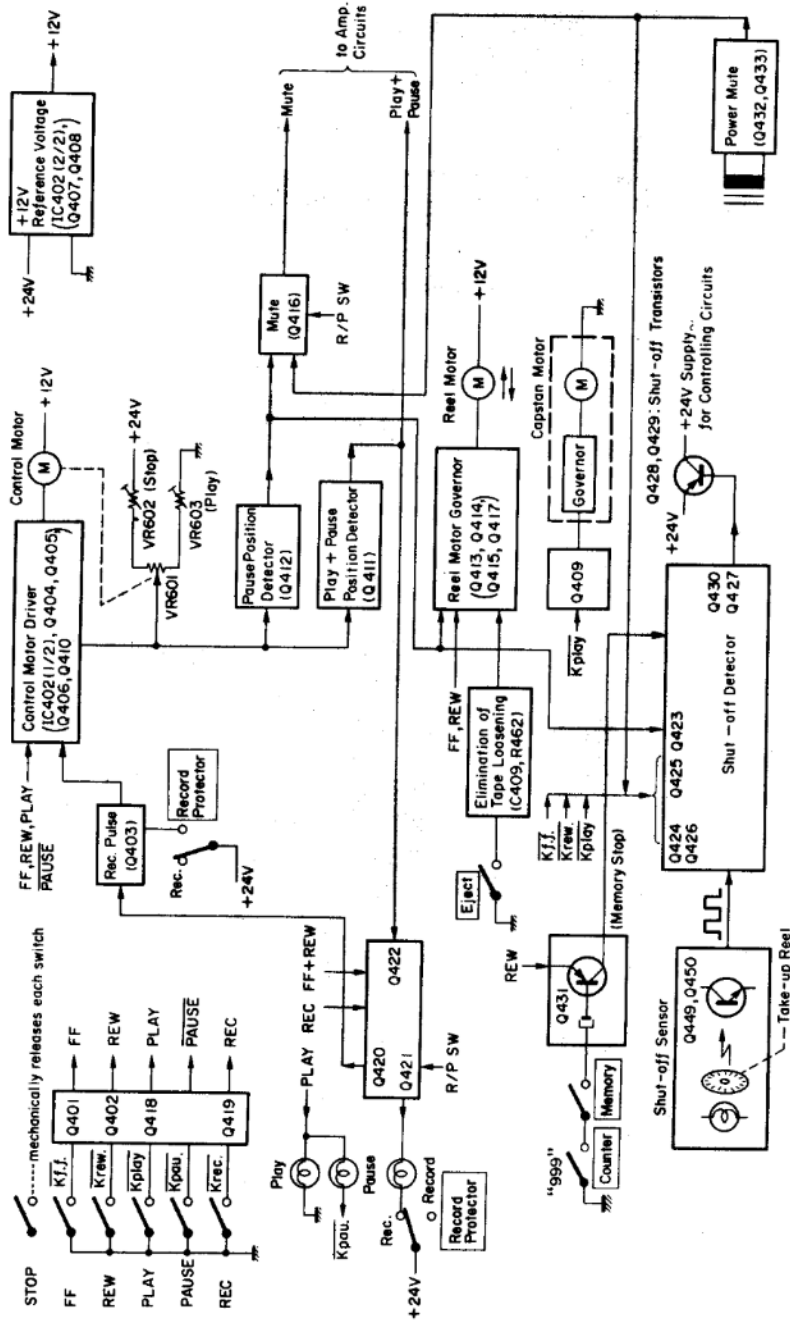

Fig. 13.2

14. SCHEMATIC DIAGRAMS

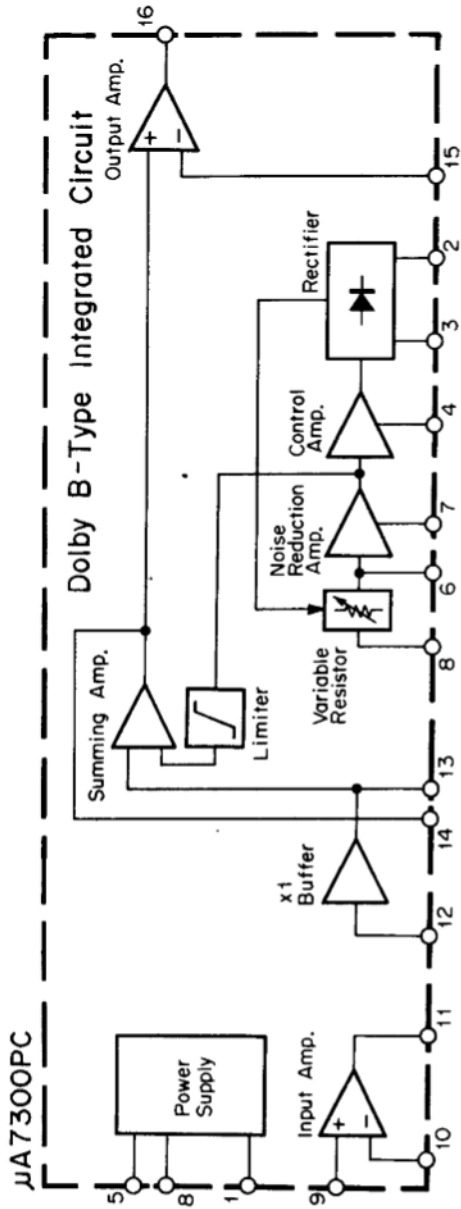

Fig. 14.1 Dolby NR IC  $\mu A7300PC$

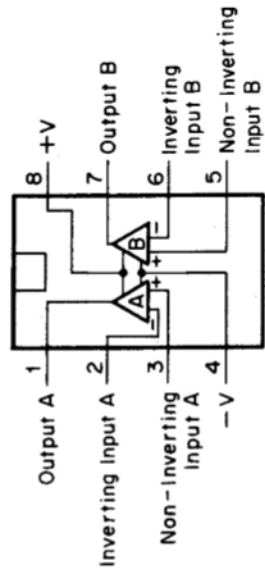
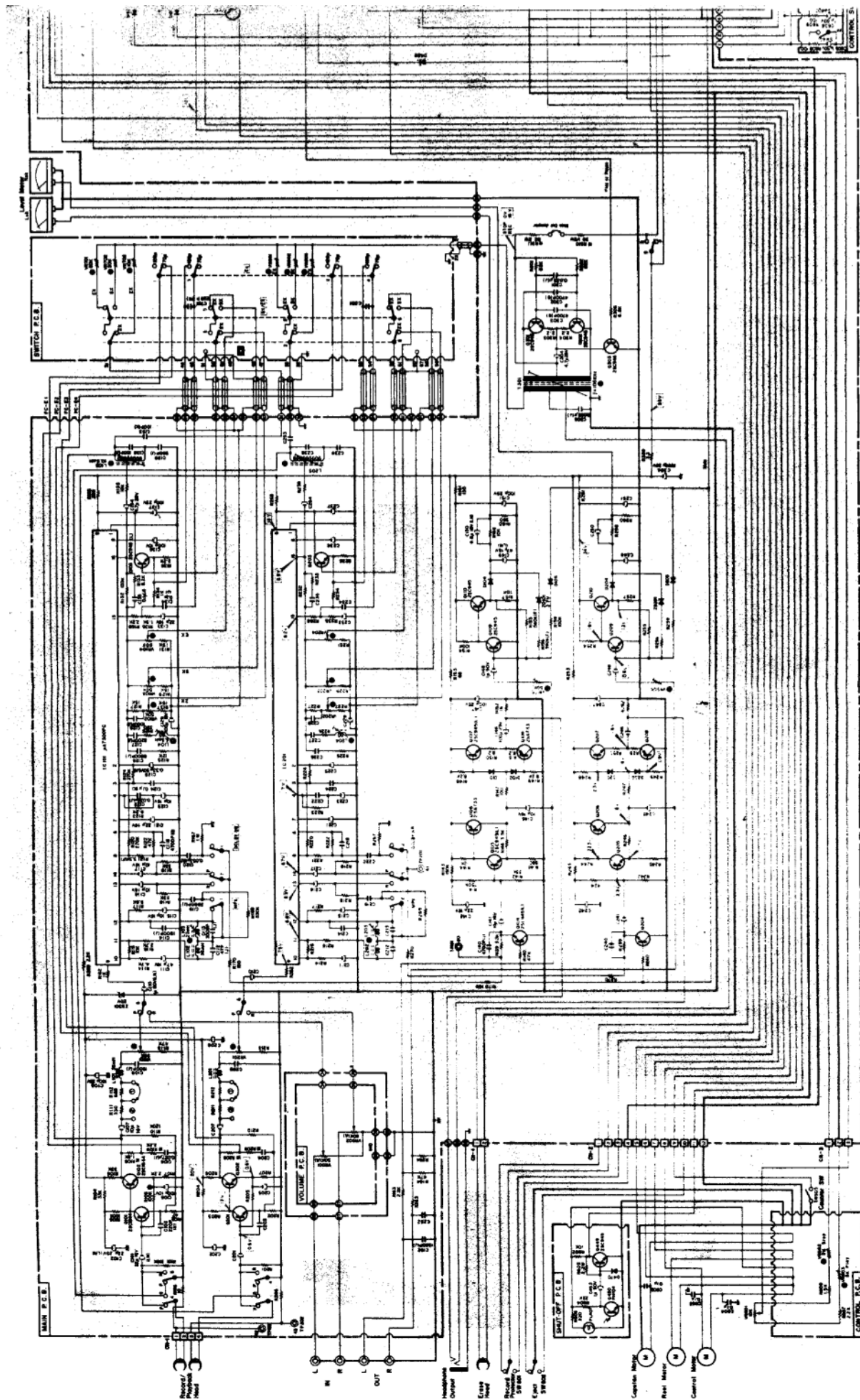

Fig. 14.2 Operational Amp. IC 4558



Notes: 1. Diode is 1SS53, 1S953  
 2. Resistor and capacitor

Fig. 14.3.1 Serial No.: A304.518705 -



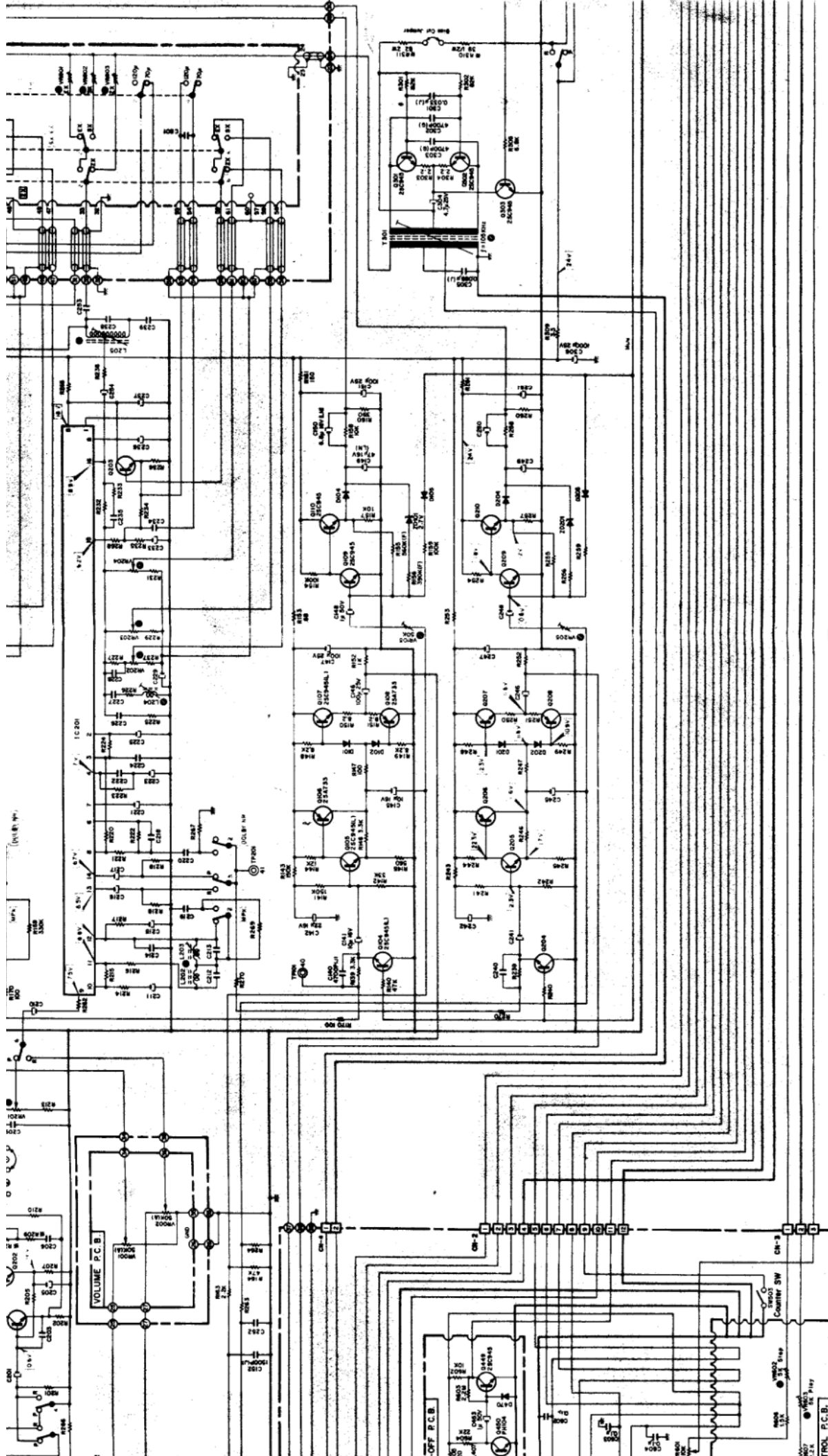
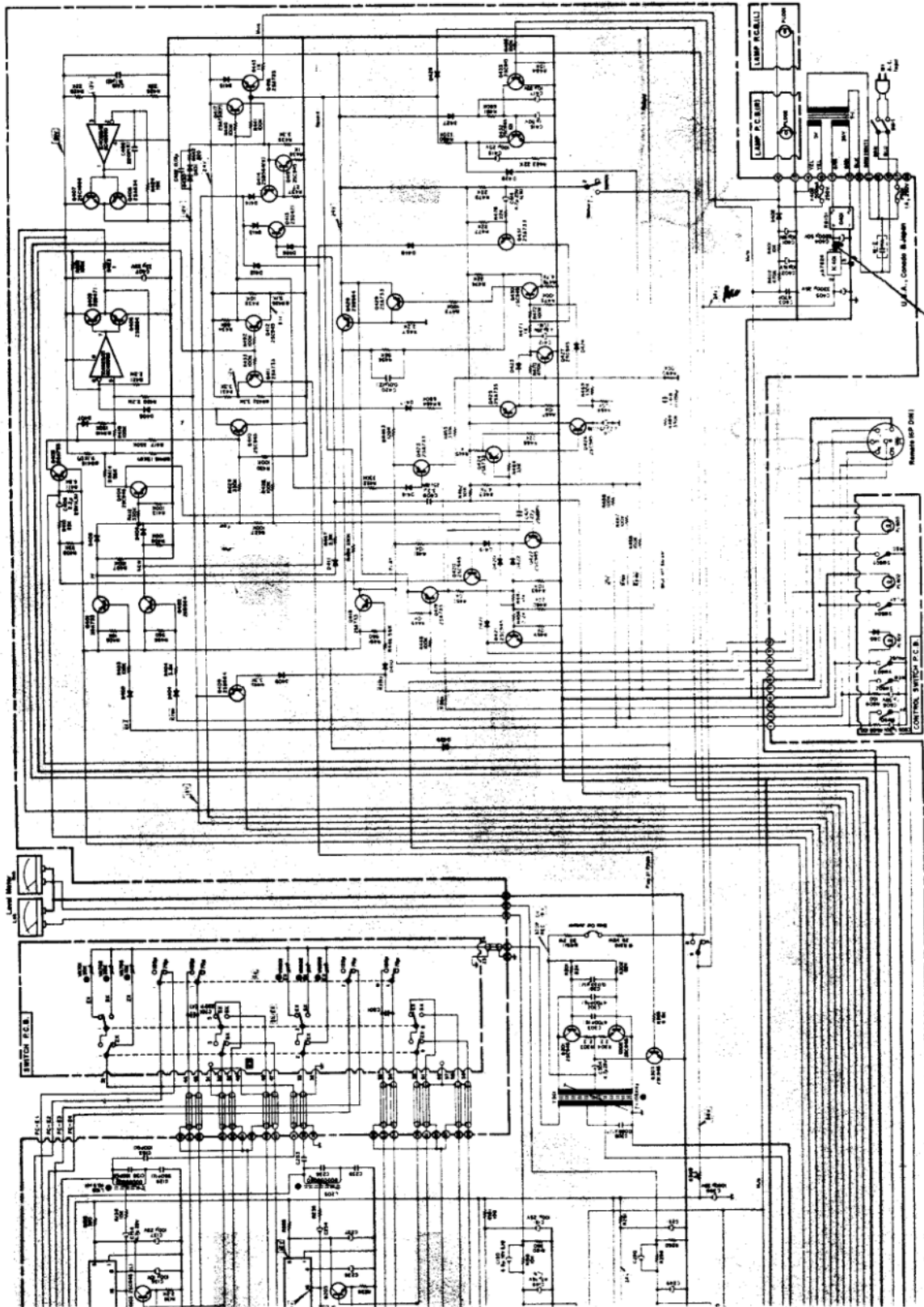
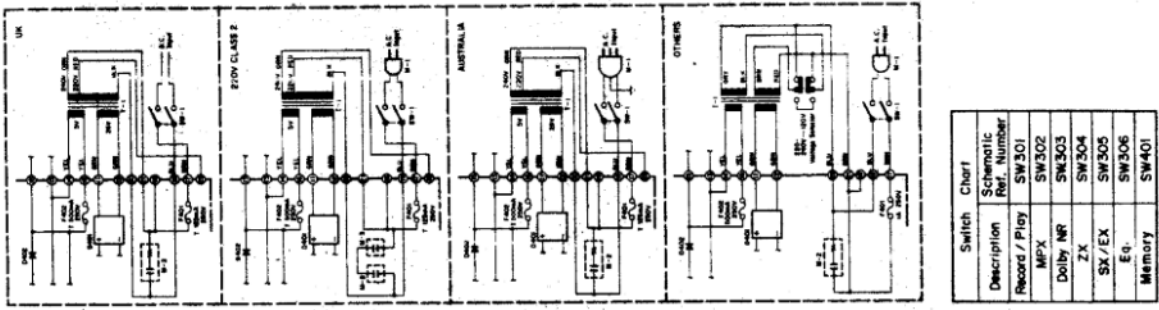

Fig. 14.3.1 Serial No.: A304.518705 -



Notes: 1. Diode is 1SS53, 1S963, or 1S1555 unless otherwise specified.  
 2. Resistor and capacitor marked with \* show typical value.

Fig. 14.3.1 Serial No.: A304-518705 -



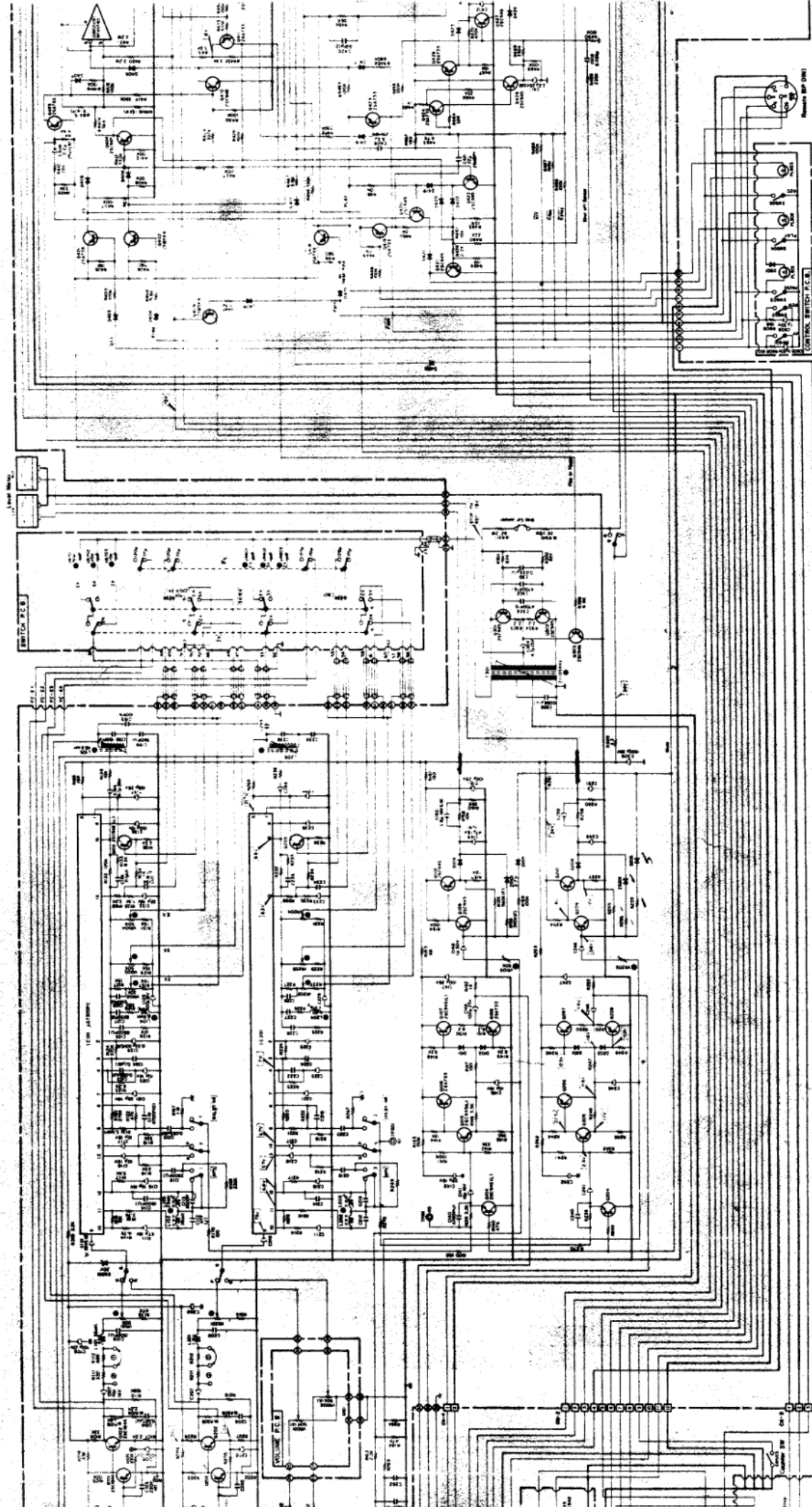

Notes: 1. Diode is  
2. Resistor

Fig. 14.3.2 Serial Nos.: A304.501001 - A304.518704

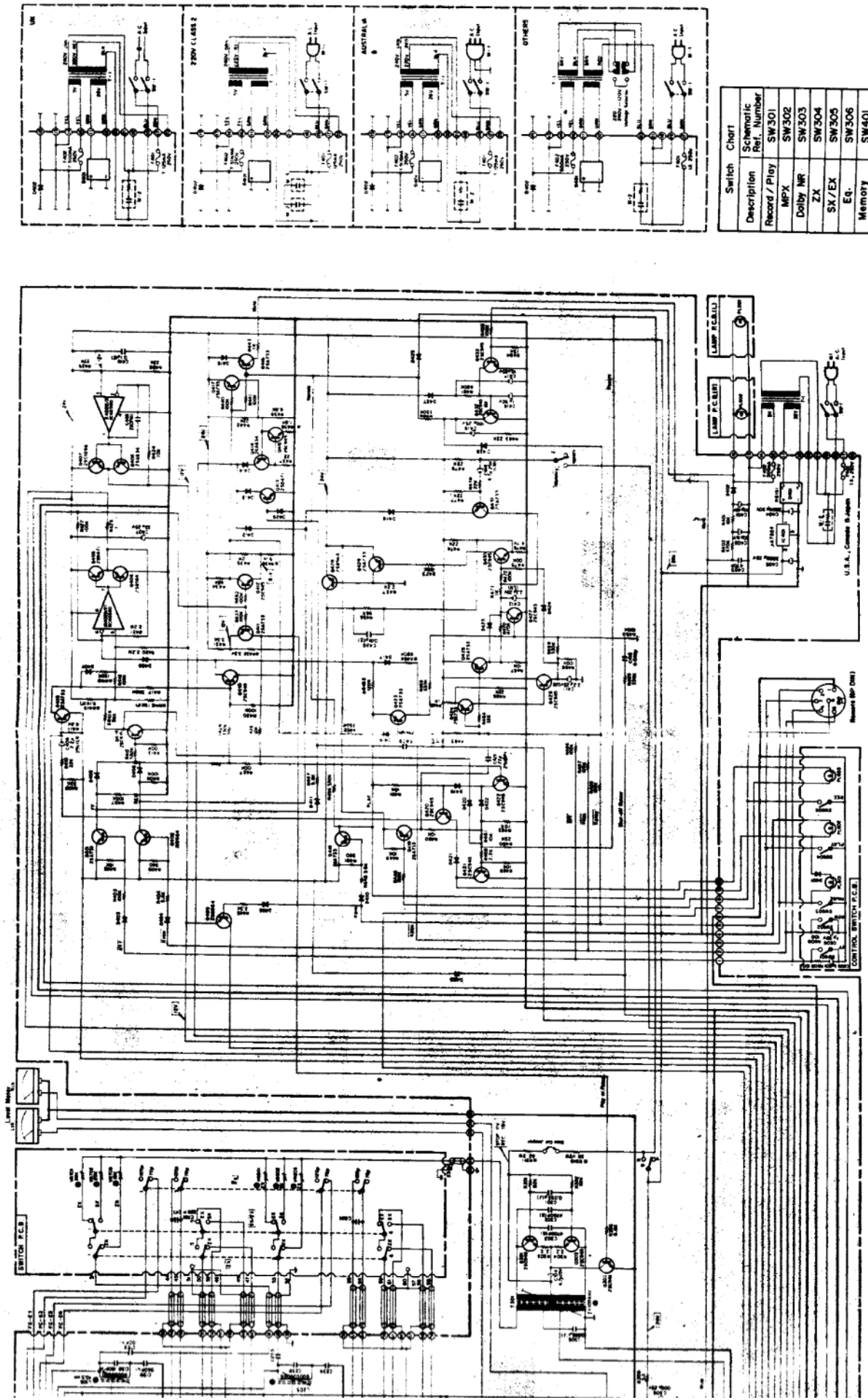

Notes: 1. Diode is 1S553, 1S953, or 1S1555 unless otherwise specified.  
 2. Resistor and capacitor marked with \* show typical value.

Fig. 14.3.2 Serial Nos.: A304.501001 - A304.518704

## 15. SPECIFICATIONS

Power Source . . . . .	100, 120, 120/220-240, 220 or 240 V; 50/60 Hz (according to country of sale)
Power Consumption . . . . .	23W Max.
Tape Speed . . . . .	1-7/8 ips. (4.8 cm/sec.)
Wow-and-Flutter . . . . .	Less than 0.12% WTD Peak, 0.06% WTD rms
Frequency Response . . . . .	20-18,000 Hz $\pm$ 4 dB (-20 dB Rec. Level)
Signal-to-Noise Ratio . . . . .	Better than 62 dB at 400 Hz, 3% THD, WTD rms (Dolby NR In, 70 $\mu$ s)
Total Harmonic Distortion . . . . .	Less than 1.0% at 400 Hz, 0 dB (ZX, EXII Tapes) Less than 1.2% at 400 Hz, 0 dB (SX Tape)
Erasure . . . . .	Better than 60 dB below saturation level at 1 kHz
Separation . . . . .	Better than 36 dB at 1 kHz, 0 dB
Crosstalk . . . . .	Better than 60 dB at 1 kHz, 0 dB
Bias Frequency . . . . .	105 kHz
Input . . . . .	50 mV, 30 k ohms
Output Level . . . . .	600 mV (400 Hz, 0 dB) 2.2 k ohms
Headphone . . . . .	10 mW (400 Hz, 0 dB) 8 ohms
Dimensions . . . . .	450(W) x 135(H) x 289(D) mm 17-23/32(W) x 5-5/16(H) x 11-3/8(D) inches
Approximate Weight . . . . .	6.4 kg, 14 lb 2 oz.

- Specifications and appearance design are subject to change for further improvement without notice.
- Dolby NR under license from Dolby Laboratories.
- The word "Dolby" and the Double-D-Symbol are trademarks of Dolby Laboratories.







Service Manual

**Nakamichi 480**