

PAM1400/1000/600/300

SERVICE MANUAL

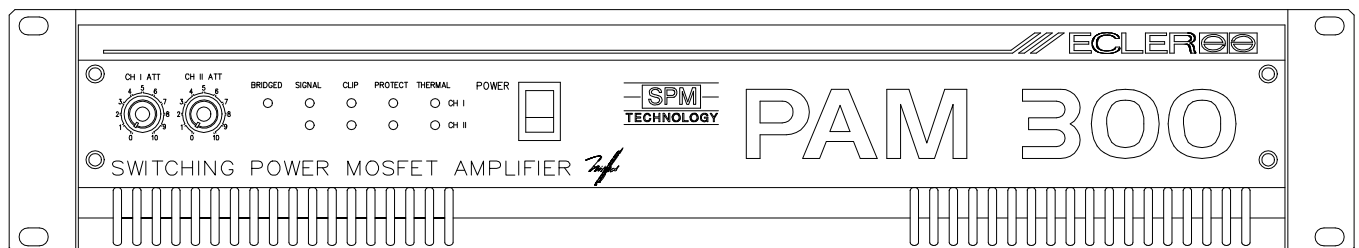
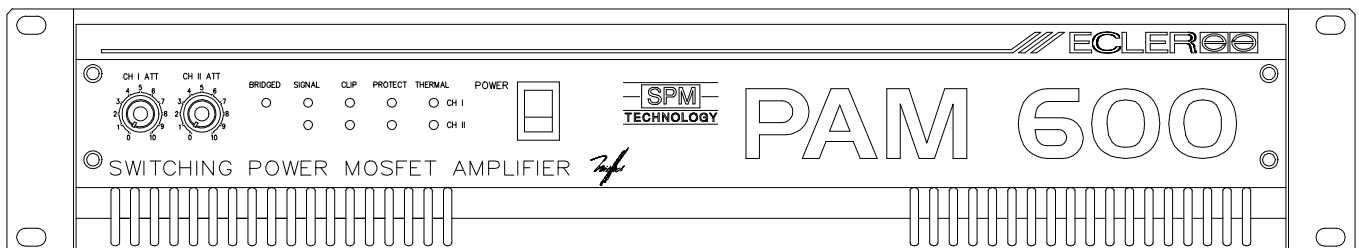
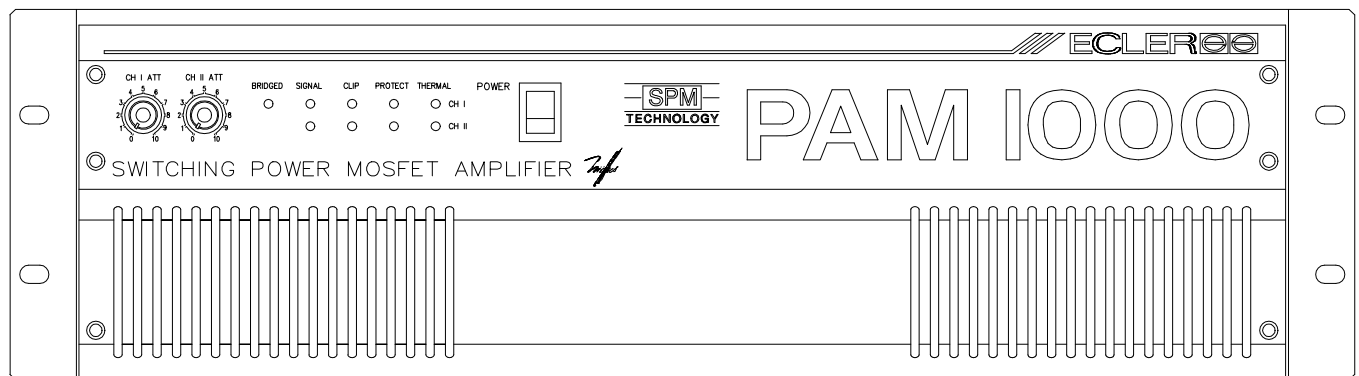
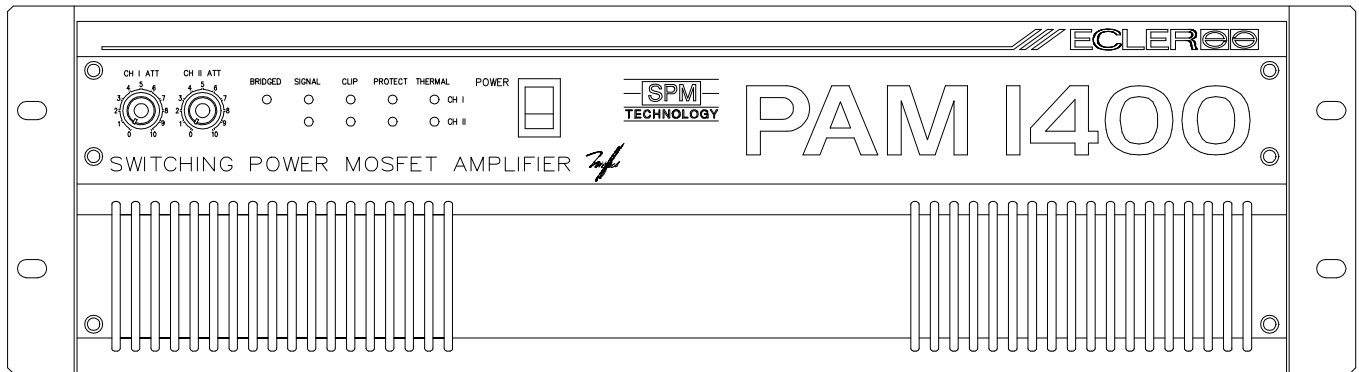

ECLEREE

AUDIO CREATIVE POWER

SERVICE MANUAL PAM1400/1000/600/300

INDEX

- BLOCK DIAGRAM
- SCHEMATICS
- COMPONENTS LOCATION SCHEMA
- TESTING AND QUALITY CONTROL
- TECHNICAL CHARACTERISTICS
- WIRING DIAGRAM
- MECHANICAL DIAGRAM
- PACKING DIAGRAM

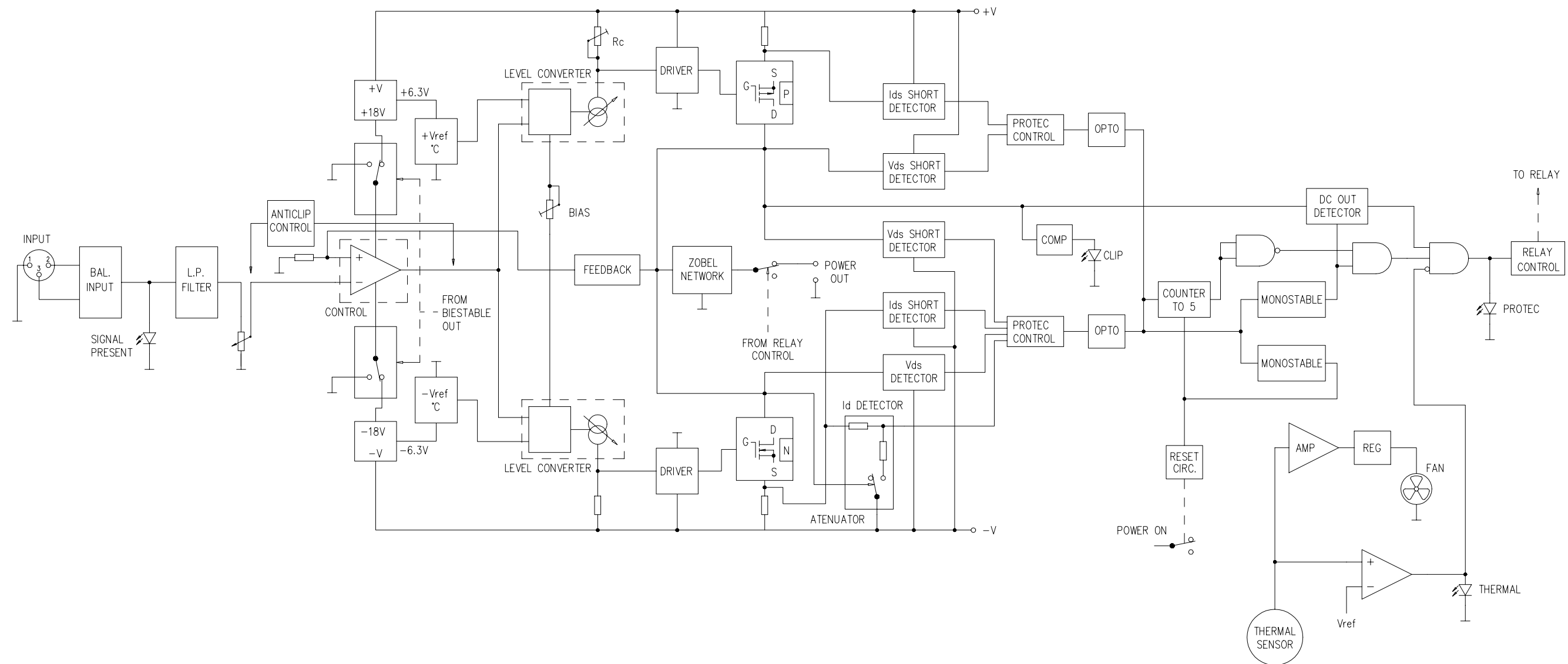

TITLE: BLOCKS DIAGRAM		MODEL: PAM1400/1000/600/300	 LABORATORIO DE ELECTRO-ACUSTICA BARCELONA ESPAÑA	
DRAWN: J.QUERALT		DATE: 241193		
CHECKED:	DATE:	REPLACES:	DRW. NO. 10.0245	REV.
		REPLACED BY:		

MODULE CIRCUIT 11.0504B OPERATION - DESCRIPTION

The control element is the operational NE5534. This is a very low noise operational, especially designed for very high quality applications in professional audio equipment, control equipment and telephony channel amplifiers.

The operational is internally compensated for a gain equal to or higher than three. Frequency response can be optimized with an external compensation capacity, for several applications (unity gain amplifier, capacitive load, slew-rate, low overshoot, etc...).

Characteristics:

Small-signal bandwidth: 10Mhz

Output drive capability: 600Ω 10V(rms) at $V_s = \pm 18V$

Input noise voltage: $4nV/\sqrt{Hz}$

DC voltage gain: 100000

AC voltage gain: 6000 at 10KHz

Power bandwidth: 200KHz

Slew-rate: $13V/\mu s$

Supply voltage range: ± 3 to $\pm 20V$

POWER SUPPLY

The BF871 and BF872 transistors are mounted in a common base configuration, in a current source structure. The current sources have a double function: polarizing the gate-source links in the MOSFETs to the limit of the conduction and moving the voltage variations at the operational output which are referred to ground to voltage variations referred to high voltage power supply. The polarization point is calculated so the voltage dropout in R_c ($R_{112}+R_{111}$) is the limit voltage of conduction of the MOSFETs (≈ 2 to $3V$), enough to carry the bias current. If we modulate in AC the base-emitter voltage, the I_c and V_{Rc} will vary proportionally. In our configuration, as the reference voltage V_{ref} is constant (it is a part of the operational power supply), we add the operational output voltage to the transistors emitter through R_e ($R_{107}-R_{108}$).

The R_c value fixes the source output impedance. We do not recommend to raise it higher than $1K\Omega$ because of frequency response and slew rate reasons. This voltage circuit's gain is, as usual in a common base configuration with R_c/R_e emitter resistor, 0.45.

POWER SOURCE STRUCTURE

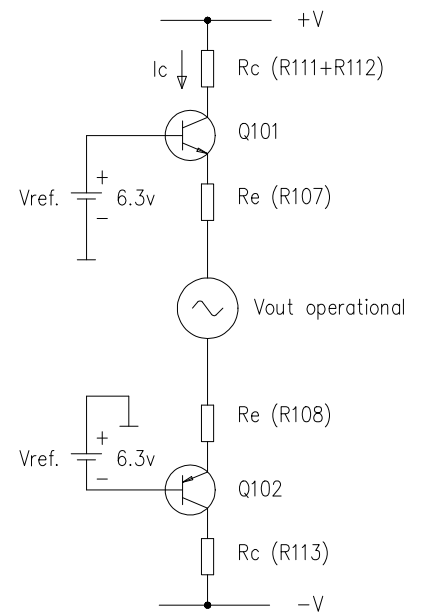

fig. 1

The bias current adjust is performed through the variable resistor connected between the emitters of the current sources R110 (5KΩ). It delivers a supplementary current (it does not go through the operational) which simultaneously increases the voltage which falls in the Rc load resistors.

This is the easiest way of acting with just one adjust over both branches at the same time. In order to adjust the bias current the adjustable resistor must be varied until a current of about 80mA circulates through each MOSFET. So, for instance, for a PAM1400 in which there are six MOSFETs it will be $80 \times 6 = 480\text{mA}$. The bias current depends on the MOSFETs temperature and the stabilizing circuit transistors temperature.

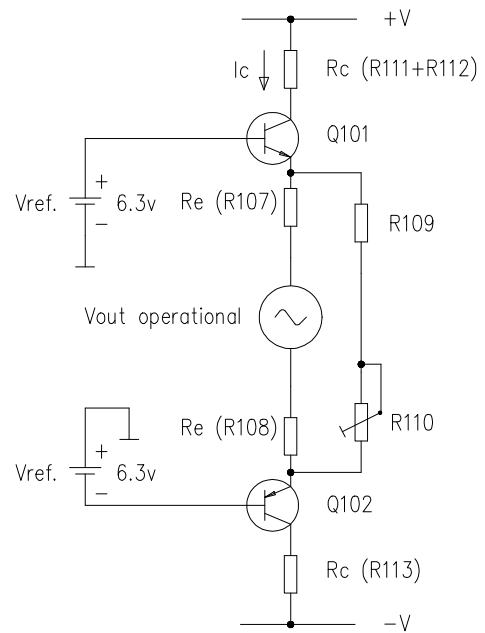

fig. 2

TEMPERATURE STABILIZING CIRCUIT

Temperature affects MOSFETs conduction in two different ways: first, the conduction threshold voltage has a negative temperature coefficient; second, the drain-source conduction resistance increases with temperature. Depending on which of the two things is predominating the temperature coefficient of the drain can be positive or negative. In our case, in which the gate-source voltage in the MOSFETs is very low when they conduct, the temperature coefficient of drain current -which is positive- is predominating.

To avoid thermal runaway in the polarizing current we must decrease the gate-source voltage as the MOSFETs get hot. Temperature stabilization is performed by modifying the reference voltage of both sources. If the temperature increases the Vref must decrease so that Ic and VRc decrease and, as a consequence, the gate-source voltage also decreases.

The circuit used is shown in figure 3. The base-emitter Vbe temperature/voltage feature is used to obtain the final result we need. The main idea is adequately choosing R1 and R2 to obtain the right temperature coefficient.

TEMPERATURE STABILIZING CIRCUIT

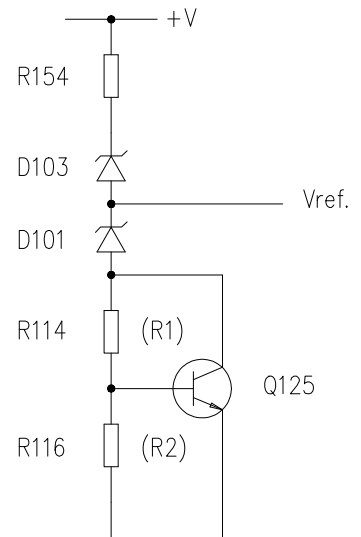

fig. 3

SYMMETRY ADJUST

The threshold voltage varies much, even between MOSFETs of the same kind. When connecting them in parallel we must be careful that they all have the same conduction current if we want equal currents circulating in all of them. If the conduction voltage of P and N channels MOSFETs is not the same they will conduct different currents, even when we apply identical gate-source voltages. As the bias current of the N MOSFETs must be identical to the one of the P MOSFETs the feedback will correct the continuous voltage at the operational output to polarize the MOSFETs with different voltages until both conduct equal currents.

If the operational output is not 0 V its capacity to give voltage and current is not the same in both senses. To avoid this we must put a symmetry adjust. It is just an adjust which allows to vary the collector resistance of one of the current sources (R111).

The symmetry adjust does not correct the asymmetrical clipping saturation of the power amplifier with real load. This happens because the conduction resistors (R_{on}) of the MOSFETs N and P are not equal. Channel P has a higher R_{on} than channel N. This characteristic depends on the MOSFET's physical construction.

POWER MOSFETs

The MOSFETs used are IRFP9240 (P) and IRFP240 (N). They are assembled in a common source configuration so they can be completely saturated.

This kind of configuration has two drawbacks compared to a common drain one: less stability (because of the configuration gain itself) and high output impedance in open loop.

The source resistances (0.22Ω) are needed for the MOSFETs to work in parallel. E.g.: Two MOSFETs excited by the same V_{gs} voltage (gate-source voltage) of 5V. If they have different transconductance curves (I_d function V_{gs}) they will conduct different drain currents; let's say 1A and 3A. The second one will dissipate more power and will get hotter.

The use of source resistances tends to match the current that each of the MOSFETs connected in parallel is conducting.

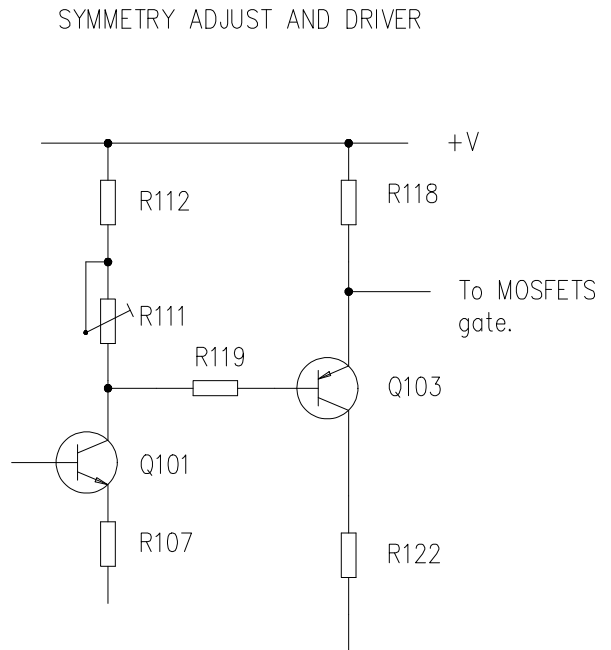
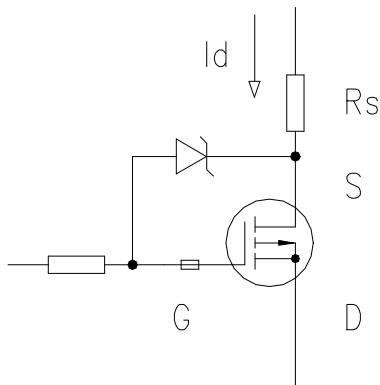

fig. 4

This resistance performs a negative feedback on the gate, lowering down the V_{gs} , relating to the drain current; like this:



$$V_{gs} = V_{gg} - I_d \cdot R_s$$

The higher the I_d , the lower the V_{gs} voltage. The gate is protected by a zener, preventing a possible overload during an unexpected change from overload to real clipping.

Given the high input impedance and the broad frequency response of the MOSFETs there is a high risk of self-oscillations if all gates are excited connected to the same node. Intercalating serial resistances and ferrite beads at the gate this possibility is minimized, because the Q of the LC network made by the inductances and gate-source capacity is reduced.

PROTECTION CIRCUIT

The protection circuit monitors the dissipated power at the MOSFETs stage. It has two basic parts:
 MOSFET I_d current detection.
 MOSFET V_{ds} voltage detection.

The goal is limiting the MOSFET so it works inside an area close to the SOA, as indicated in the figure. We chose channel N because, due to construction reasons, its SOA is lower.

ZONE A. This zone is for very low loads, around 0Ω . As the load voltage is very low, the voltage held by the MOSFET will always be high. The protections should be activated with very low current.

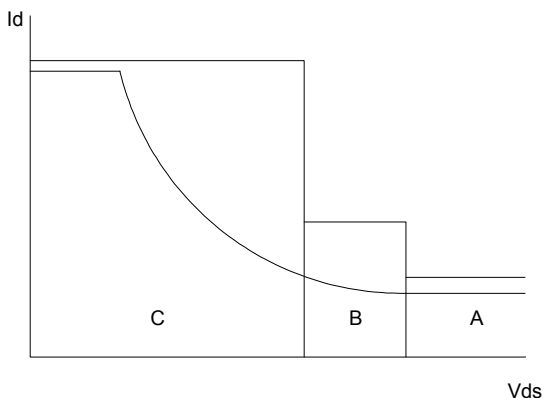

Fast protections and some of the slow ones are working in this zone. The circuit that configures the fast ones is made of: D120, D121, D123, R174, R175, R176, R177, R178, R179, C127, Q122 and Q123 for the N channel. There is also an equivalent circuit in the P channel. These start working when there is a sudden current variation because of a shortcircuit or a transitory. The reaction time -from the exact moment when these things occur to when the current stops circulating through the MOSFETs- is about $80\mu s$.

The time constant is given by C127, R174 and R179 and the load circuit made by the LED diode of the IC104 (opto-coupler).

Please note that in order for the protection to be activated Q122 and Q123 must conduct simultaneously, through which R174 is linked to negative power supply, being C127($1\mu F$) loaded very quickly through this resistance, activating the LED of the opto-coupler, sending a pulse to the protection circuit, which will open the corresponding channel's relay, being this way the output from the power amplifier disconnected from the load (0Ω), in this case. Q122, together with the zeners and the base polarization resistances, configure the voltage detector (this group is in parallel with the V_{ds} voltage of the N MOSFET).

Q123, together with the resistances which make the base divider, configure the current detector (this divider takes its voltage from one of the source resistances of a N MOSFET, which is proportional to the current circulating through itself).

The threshold separating zone A from zone B is determined by the D125 zener. When this zener stops working and there is no current circulating through it because the Vds voltage is lower (let's remember this circuit is also in parallel with this voltage) or, what is the same, the load voltage grows because it is not 0Ω anymore and has a given value, like 0.5Ω to 1Ω, and the help given by D126 stops so more current will be needed for the shot. We have climbed the first stair of the stairway of the SOA graphic.

When the zeners D124 and D118 stop working because the load voltage goes on growing (values higher than 1Ω) or -what is the same- the Vds decreases, the Q125 transistor does not receive current anymore in its base and so it is shorted, allowing Q124 to enter conduction. This way R172 stays in parallel with the base-emitter of Q121, making up a voltage divider with R173. This divider will climb another stair of the stairway and enter the ZONE C.

The link between the module's protection circuit and the relays' control circuit is made through IC103 and IC104 which are, as mentioned earlier, opto-couplers, just to insulate the existing high voltages at the power amplifying module, ±90V in the case of the PAM1400, and the power supply voltage of the existing logic circuits in the relays' control card.

Once the pulse generated by the protections is detected, the control circuitry resident in the protection card, apart from opening the corresponding relay, returns the signal A.O. SUPPLY CONTROL to the module, which cuts by means of Q119, Q120 and IC102 the operational's power supply.

This is the way to insure a fast and safe cut of the Id current in the MOSFETs (around 80μs time), because they stop receiving their respective reference voltages and, consequently, their Vgs polarization voltages so they are cut. The circuit is shown in figure 9 and its operation is very simple.

When the A.O. SUPPLY CONTROL (+10V) signal appears, the Q119 transistor starts conducting, shortcircuiting to ground the positive power supply of the operational. On the other hand, the signal is also applied to the IC102's LED (opto TIL112 (4N35)), which puts its internal transistor and Q120 into conduction, connecting the negative power supply of the operational to ground.

N CHANNEL FAST PROTECTIONS CIRCUIT

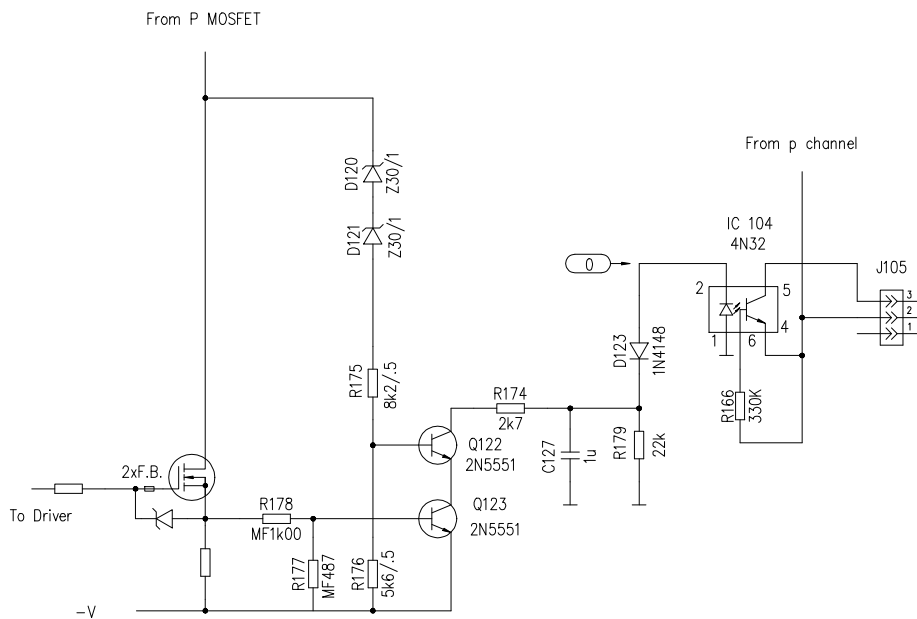

fig. 5

SLOW PROTECTIONS AID CIRCUIT
(A) STEP SOA DIAGRAM

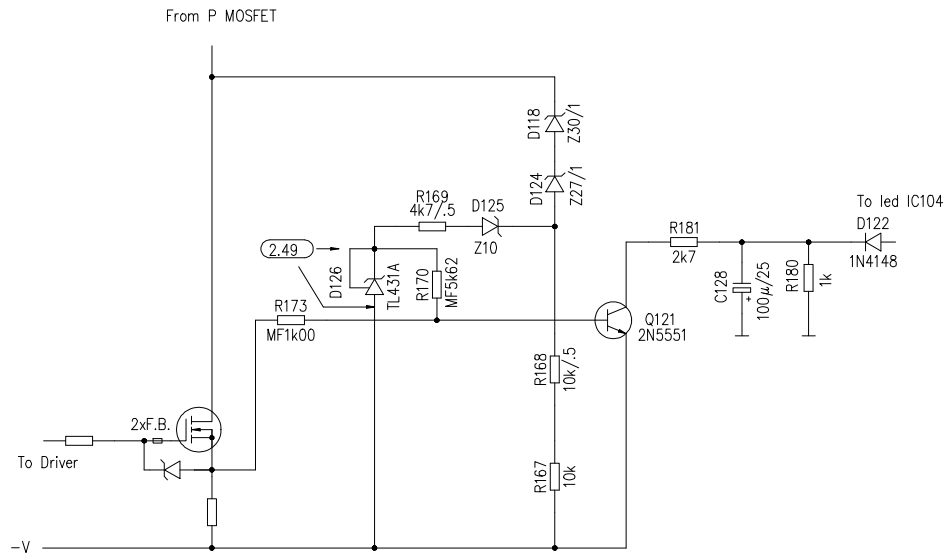

fig. 6

SLOW PROTECTIONS CIRCUIT
(B) STEP SOA DIAGRAM

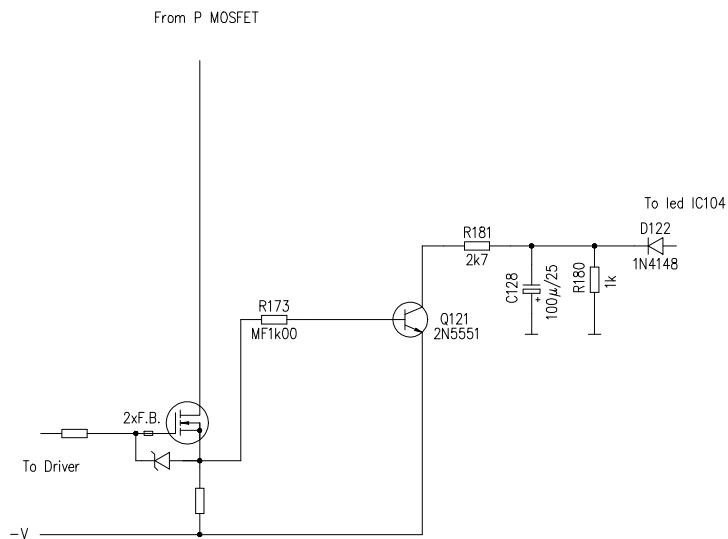

fig. 7

SLOW PROTECTIONS CIRCUIT
(C) STEP SOA DIAGRAM

From P MOSFET

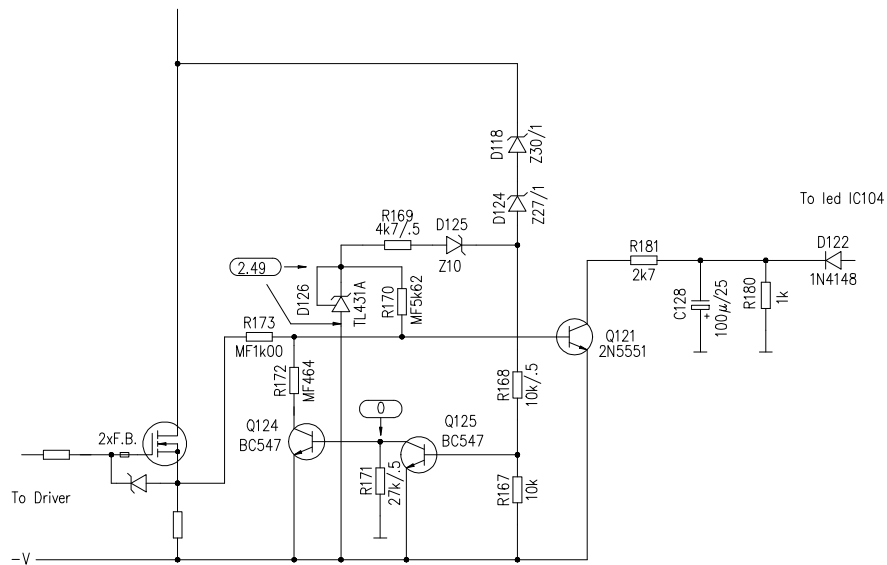

fig. 8

OPERATIONAL AMPLIFIER POWER SUPPLY CONTROL

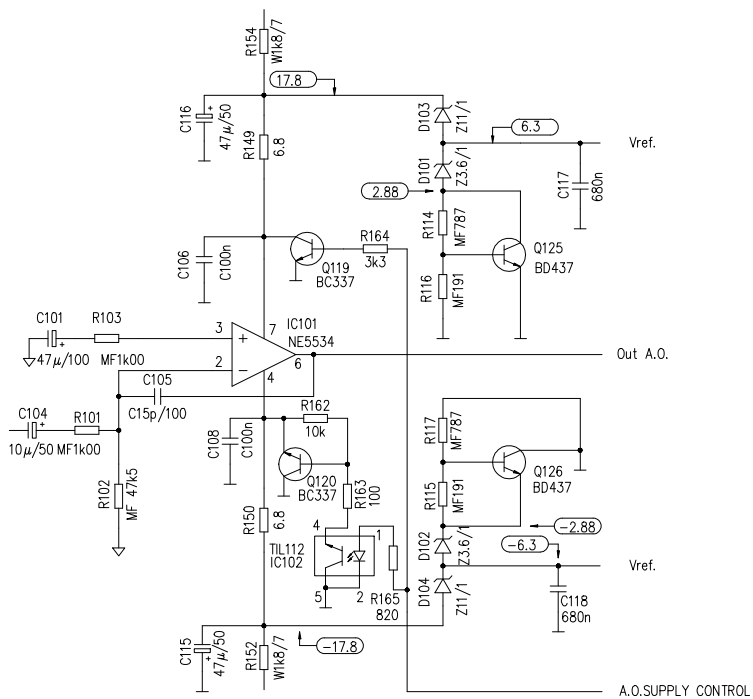

fig. 9

ZOBEL NETWORK

This circuit tries to get a constant load impedance for the power module, in spite of the amplifier's load and frequency, to avoid phase shifting of the feedback signal.

The values have been experimentally calculated through a study with square signal by trying to minimize the power amplifier's ringing with very capacitive loads ($2,2\mu\text{F}/4\Omega$).

The Zobel Network eliminates possible oscillations of the MOSFETs between 5MHz and 10MHz, too. This is why it must be physically placed at the module's output, avoiding long wiring. Great care must be taken for the signal not to be too shifted at the output, because the feedback could turn negative.

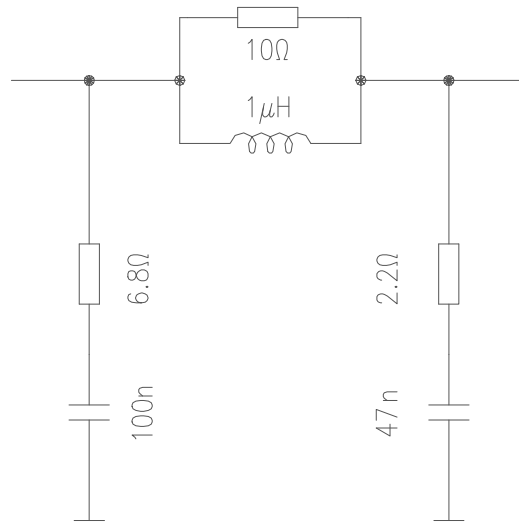

FEEDBACK

The whole amplifier is compensated with just one capacity, which places the amplifier's general pole at:

$$F_p = \frac{1}{2 \cdot \pi \cdot R_f \cdot C_f} = 140\text{KHz}$$

$$R_f = R106$$

$$C_f = C109-C110$$

PROTECTION CIRCUIT 11.0411 OPERATION - DESCRIPTION

The circuit is configured by:

- A POWER SUPPLY.
- A THERMAL PROBE DC AMPLIFIER.
- A TEMPERATURE DETECTOR.
- A DC OUT DETECTOR PER CHANNEL.
- A CLIP CIRCUIT PER CHANNEL.
- A RESET (TURN OFF/TURN ON) CIRCUIT.
- A BINARY COUNTER PER CHANNEL.
- TWO MONOSTABLE CIRCUITS PER CHANNEL.

The circuit power supply is performed through various sources: +V, module's power supply. This voltage feeds the relays circuit, manual reset circuit and part of the clip circuit. Alternate voltage from a transformer's secondary (manual reset circuit).

There is also a stabilized 10V power supply which feeds the card's circuitry, made of IC301 (7805) plus the zener D302 (Z4.7) $4.7+5 \approx 10V$. We will also need a regulated power supply to get 14Vmax at 0.7A, which can be obtained with IC302 (7805) plus an auxiliary circuitry that will be analysed below.

The cooling fan speed is automatically regulated in relation to the power module's temperature, which is read by a thermal probe (LM35D), jointly linked to the heat sink.

This high sensitivity thermal probe gives variations of 10mV for every °C. This voltage is picked up and amplified by the IC305 (LM358). Of course, there is a probe for each L and R heatsink. The output of both amplifiers is linked through two diodes D304 and D305, making an O gate, whose cathodes go to the regulator, applying the DC of any of them to the regulator. This provides a variable voltage at its output which oscillates from a minimum of approximately 7V for a temperature of 20°C (cold heatsink) to a maximum of 14V for temperatures of 76°C or higher.

The gain of the amplifiers has been calculated for this temperatures window. The maximum voltage allowed by the heatsink in order to work properly is 14V. This maximum is given by the zener D305 (Z9.1/1); as the regulator is a 7805 the voltage will be -as maximum- $9.1+5 = 14.1V$. When the zener is not working (not enough voltage) the voltage on the fan will be the output amplifiers', less 0.6V (diodes fall), plus the 5V of the IC302.

POWER SUPPLY AND THERMAL PROBE DC AMPLIFIER

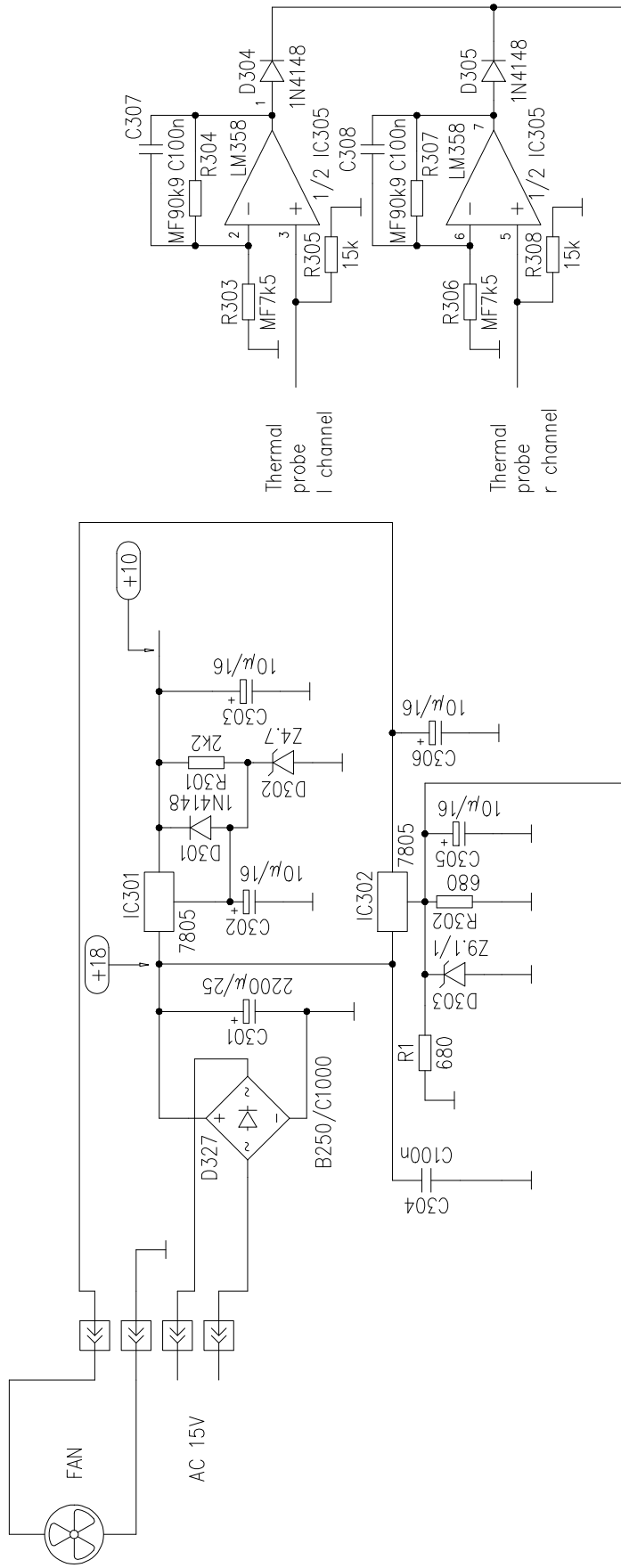

fig. 1

TEMPERATURE DETECTOR

This circuit is calculated to operate over the output relay opening it if any of both modules' temperature exceeds 90°C, approximately. It is made with a comparator per channel (L-R), resident in the same IC306. Both share a reference voltage provided by D306 (TL431A), which gives excellent stability at that voltage $\pm 1\%$. These comparators receive, like the DC amplifiers, the signal from their probes, comparing them with the Vref. Once this voltage is surpassed by any of both probes, the output of the corresponding comparator is balanced to the power supply (+10V), acting through D307, R318, D308 and R319 over the respective bases of transistors Q301 y Q307, which makes the corresponding relay open. This output is also connected to the THERMAL LEDs, which light up as the relays are open.

Note that each time the relay is open through any of the variables which act upon it the PROTECT LED must light up. The circuit acting over this LED is made of R327, R328, R329, R4, R5 and Q303. When Q302 stops conducting (open relay), Q303 receives its base current through R327, R326, R6 and the relay's coil, putting this transistor into saturation. This way the LED is linked to the power supply (+V) by means of the group of resistances R328, R329, R4 and R5.

TEMPERATURE DETECTOR CIRCUIT

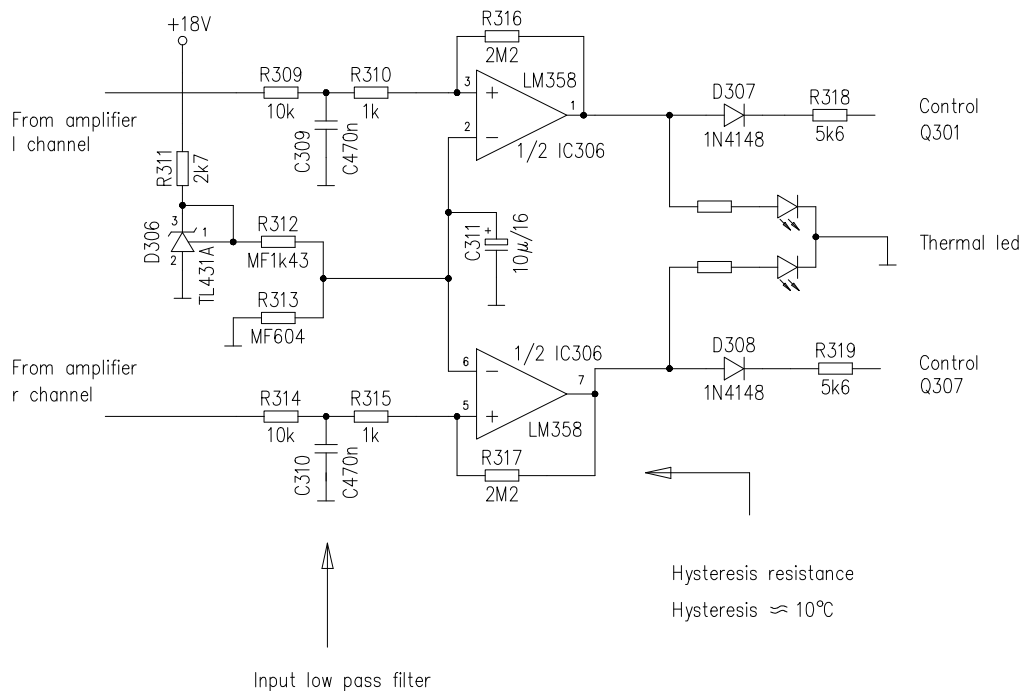

fig. 2

RELE CIRCUIT AND PROTECT LED

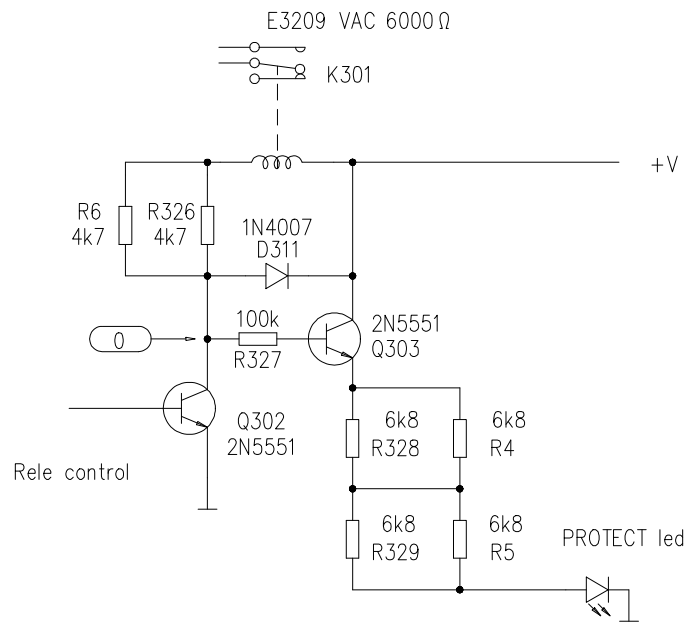

fig. 3

DC OUT CIRCUIT

The circuit shown in the figure corresponds to the DC OUT of channel L. The goal of this circuit is protecting the loudspeakers when, because of a module fail, there is some DC appearing at the output. The voltages indicated in the figure correspond to rest state and they are given by the dividers made of R320-R322 and R332-R323.

The resistances R323-R322 are linked by their extreme to the leg 7(Q) of the monostable IC310 (4538), which has +10V at rest state. On the other hand R320-R321 are linked by their extreme to the L output, which, in these conditions, has 0V respect to ground. If we apply Ohm's Law to these dividers we will obtain the above mentioned voltages.

Let's remember briefly the function of a NOR gate like the HEF4001B.

A	B	C
0	0	1
0	1	0
1	0	0
1	1	0

Let's suppose there is a continuous voltage appearing at the module output, because of any malfunction.

This makes the voltage dividers lose balance, no matter if the above mentioned voltage is positive or negative, the gate goes to 0V, the base Q302 loses the current stream and, as a consequence, the relay K301 opens. The aim of the zeners D309 and D310 is protecting the gates, avoiding the voltage in them to be higher than 8.2V when the voltage is positive and lower than -0.6V when it is negative; as you can see, the zener plays the role of a diode.

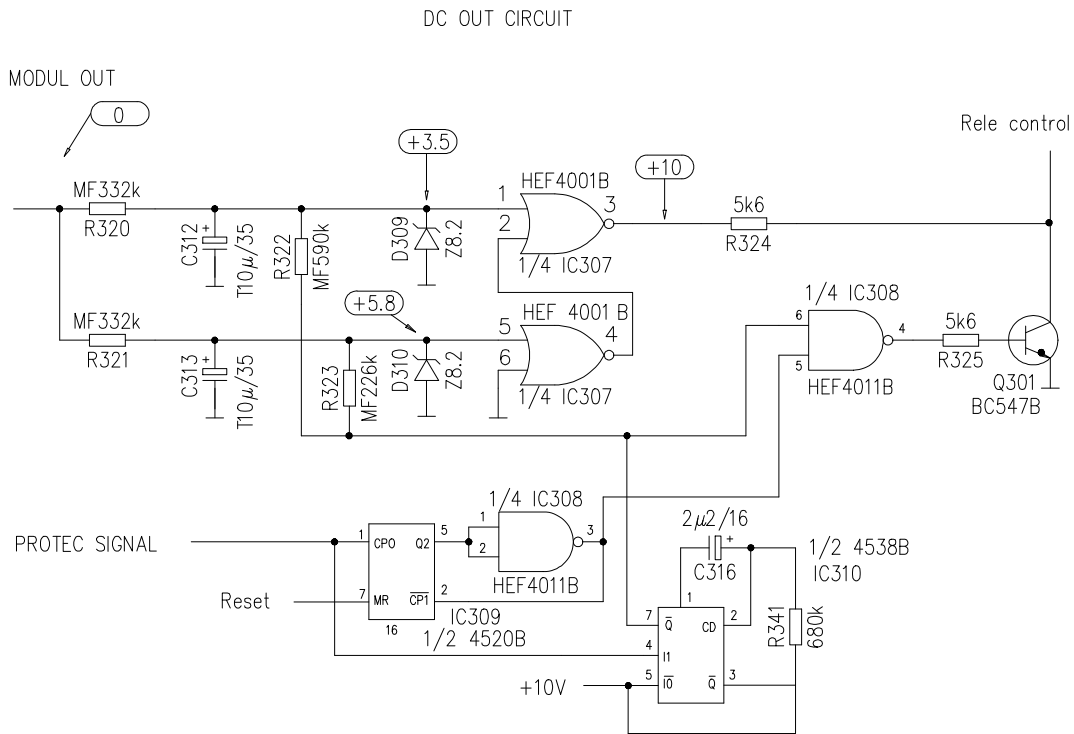

fig. 4

CLIP CIRCUIT

The other half of IC307(4001) is used in the clip circuit. Given that we have two gates more and we just need one for our purposes we will connect them in parallel for a higher output current and a more effective LED lighting up.

The clip threshold or point where we want the LED to light up is determined by the zener D313. In our case it is between 0.5 and 1dB or, what is the same, when the output signal level over the load reaches a value close to that of the power supply (+V), exactly $V_{out} = V - 5.6$, moment in which Q304 loses the base-emitter voltage stopping conduction; this makes the zener D312 voltage disappear (0V) and the output from IC307 go to "1" logic (+10V), making the LED light up.

CLIP CIRCUIT

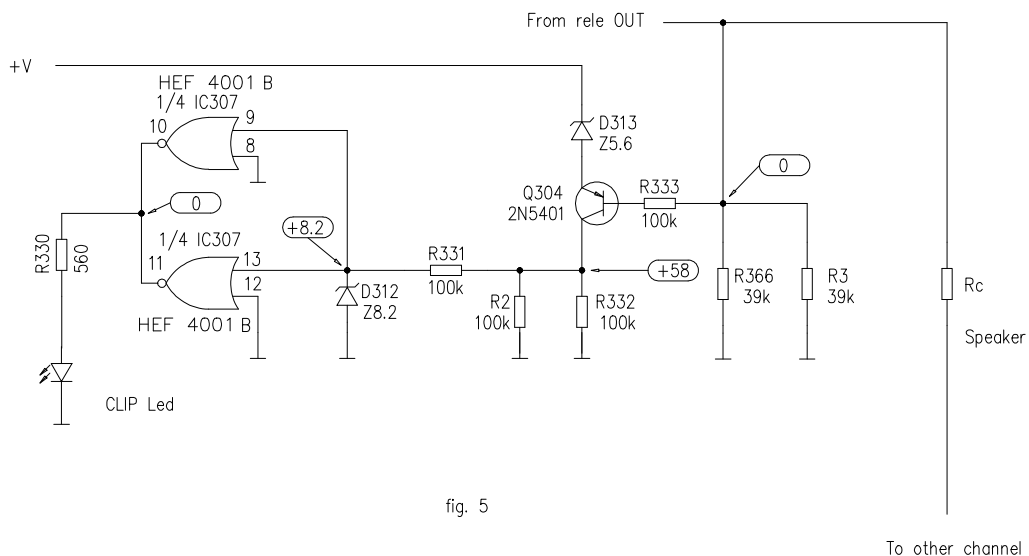

fig. 5

To other channel

GENERAL RESET CIRCUIT (TURN OFF/TURN ON)

TURN OFF RESET. This circuit starts working when the AC current from the transformer secondary disappears or, what is the same, when we turn the power amplifier off by pushing the power off switch, actually disconnecting it from mains.

Circuit operation: The AC signal present at the anode D321 is rectified by this, attenuated and filtered by R13, R348, R347 and C322, applying it to the base of Q306, which is conducting into saturation and, as a consequence, Q305 is cut. When this signal disappears Q306 is cut and then Q305 has its base fed through R345, R346 and R14 from the +V power supply, which has begun to lose voltage -because we have just cut the mains- but, because of the high capacity value of the filter condensers, there is enough time to saturate Q305, which puts the resistances R15 and R344 (50Ω) in parallel with the power supply (+10V) of the logic circuitry, completely discharging the capacities of the circuit, leaving it ready for a new reset pulse -the connection one-, what warranties the new turn-on, even with very short time intervals (.1s) between turn-off and connection pulses.

10V FAST DESCHARGE CIRCUIT

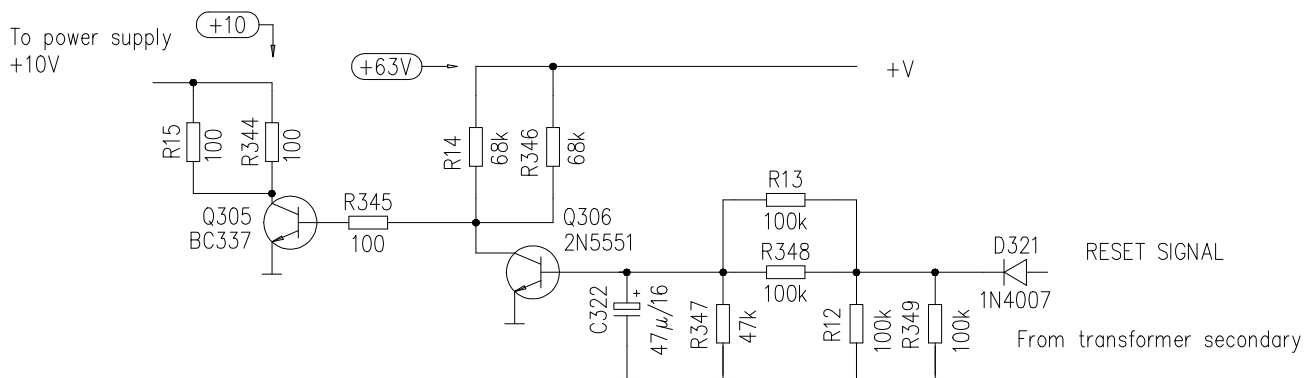

fig. 6

CONNECTION RESET

This is made of C315, R336 and D314. It is the classical reset circuit, used in lots of applications.

In the exact connection moment the condenser C315 is not charged, with a high amount of current circulating through it, or a high voltage in R336. This current decreases as the condenser is charging until it disappears. At the same time, the voltage -in the extremes- of the resistance goes from maximal, in the beginning, to 0V. This way we get a pulse whose duration depends on the time constant RC. The aim of the diode D314 is a fast discharging of C315 during disconnection.

BINARY COUNTER HEF4520

This is a 4-bit double binary counter. Configured in a way in which when there is the binary code equivalent to decimal number 5 at its output -so this is 1 0 0- it is blocked in this position, until it receives a new MR reset pulse. The blocking action is performed by the NAND gate between legs Q2 and CP1. At this state Q2 becomes "H" one logical, the NAND changes its state putting the leg CP1 to "L" zero logical and -as you can see in the table of functions- the mode can not change in this conditions.

CPO	CP1	MR	MODE
↑	H	L	counter advance
L	↓	L	counter advance
↓	X	L	no change
X	↑	L	no change
↑	L	L	no change
H	↓	L	no change
X	X	H	Q0 to Q3=low

The general turn-on reset initializes the counter. Every time it receives a pulse from the module opto-couplers because of a protections shot it is counted. If during an interval of approximately 5 minutes it does not receive any other pulse, the counter will go back to the original zero state, because it receives a new MR reset pulse from the monostable IC311, whose time constant is approximately 5 minutes (R342,C319). This monostable begins counting from the very first pulse received by the counter, because both are linked to the PROTECT SIGNAL from the module and, consequently, activated at the same time.

If during this time interval (about 5 minutes) a minimum of 5 successive pulses are received, these will make the counter block at that position. This translates into a logical "1" at the Q2 leg of the counter, a "0" at the NAND (IC308) output; this zero makes a "1" at the output of the next NAND, giving a result of "0" at the collector of Q301, so Q302 is not conducting and the relay K301 remains open. It will stay this way until the reset from the monostable happens or there is a manual mains disconnection by pushing the power off button.

The reset circuit associated with the monostable is made of C320, D320, R339 and D318 (above we have always been referring to channel L). By means of diodes D317 and D318 we build an "O" gate, with which we apply any of the above mentioned reset pulses to the counter.

BINARY COUNTER CIRCUIT AND
RESET MONOSTABLE CIRCUIT

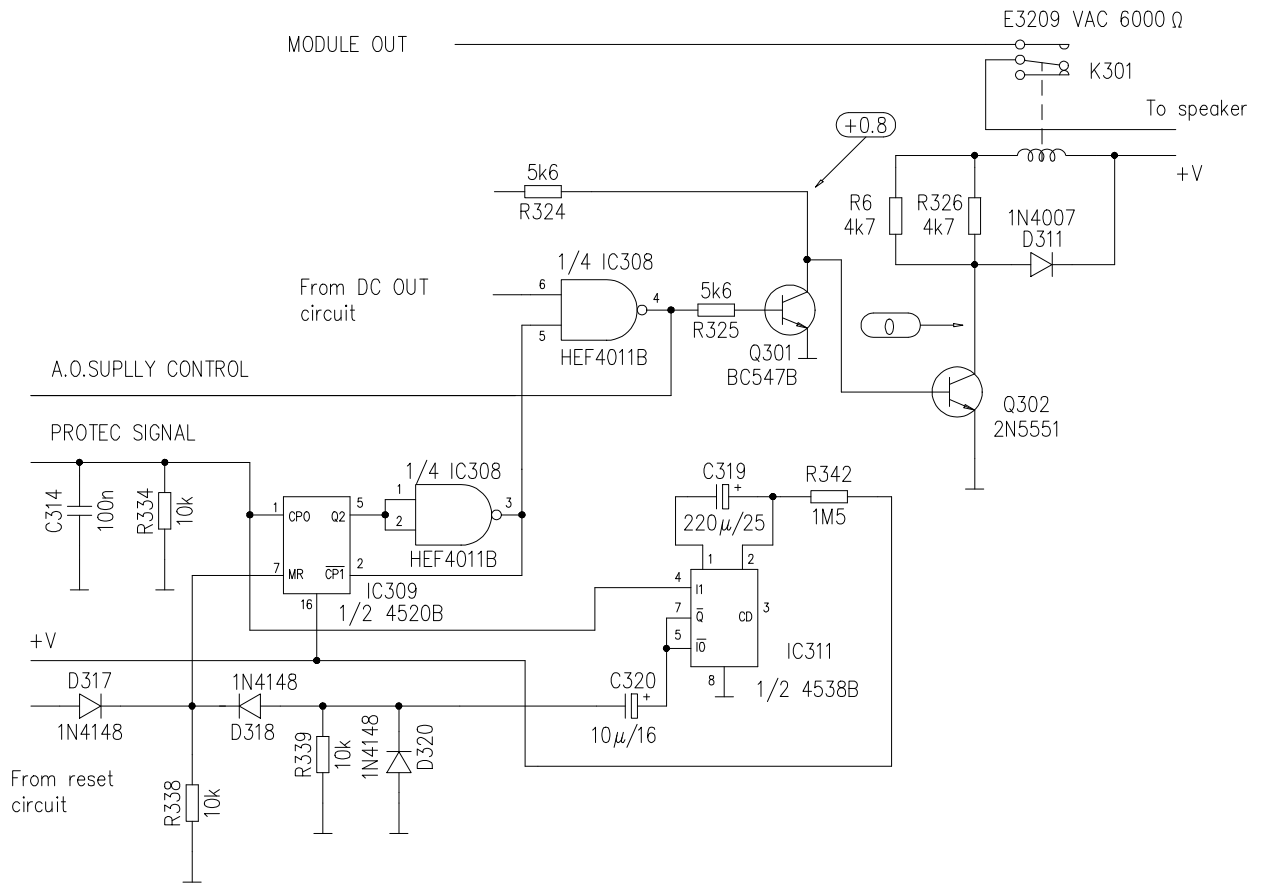

fig. 7

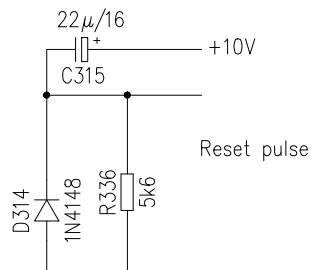

fig. 8

STANDBY MONOSTABLE

The only thing left is the function of the monostable made of IC310 (4538).

Like the counter and the monostable IC311 (4538), this circuit is connected to the PROTECT SIGNAL, too. Its output is "1" in rest state and becomes "0" during an approximate time of 1.3 seconds, which is given by the constant RC of the circuit R341 C316.

This leads to two situations: First, putting a "0" in one of the legs of the NAND (IC308) generates the immediate opening the relay, as we have seen before. On the other hand the voltage divider of the DC OUT circuit is put off balance. The monostable time is calculated to be long enough to unload the capacities of C312 and C313. This way we get a DC OUT circuit initialization as we had done a manual reset (disconnection from mains), causing the typical turn-on STANDBY time for each of the disconnections of the relays because of the protections shooting. Let's take into account that the system is locked after the fifth disconnection.

STANDBY MONOSTABLE

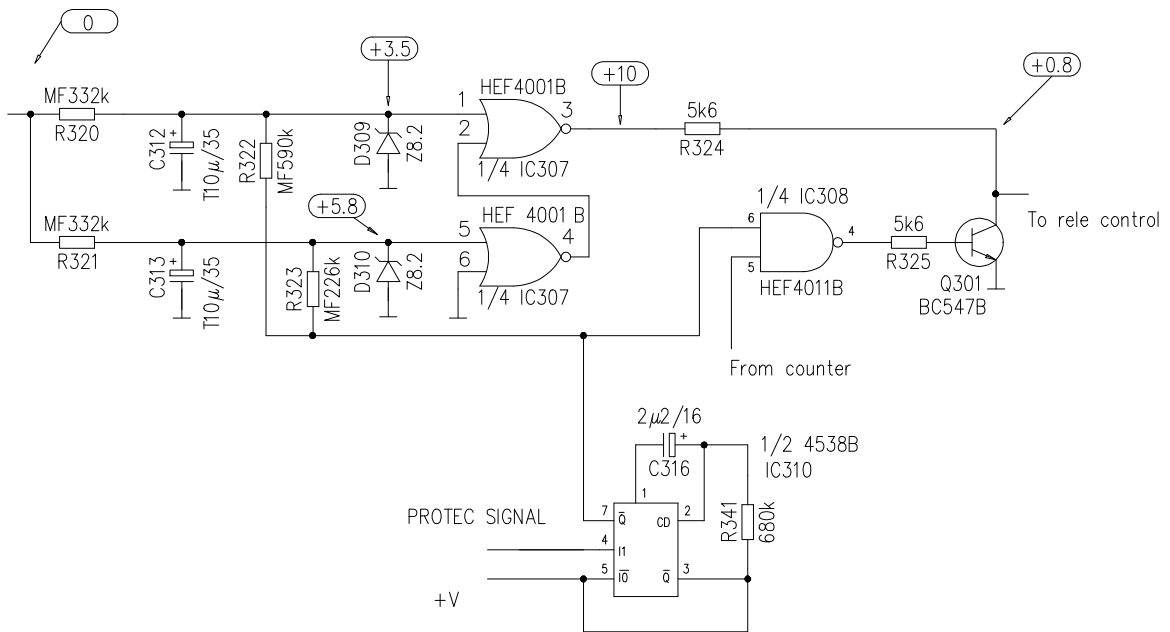
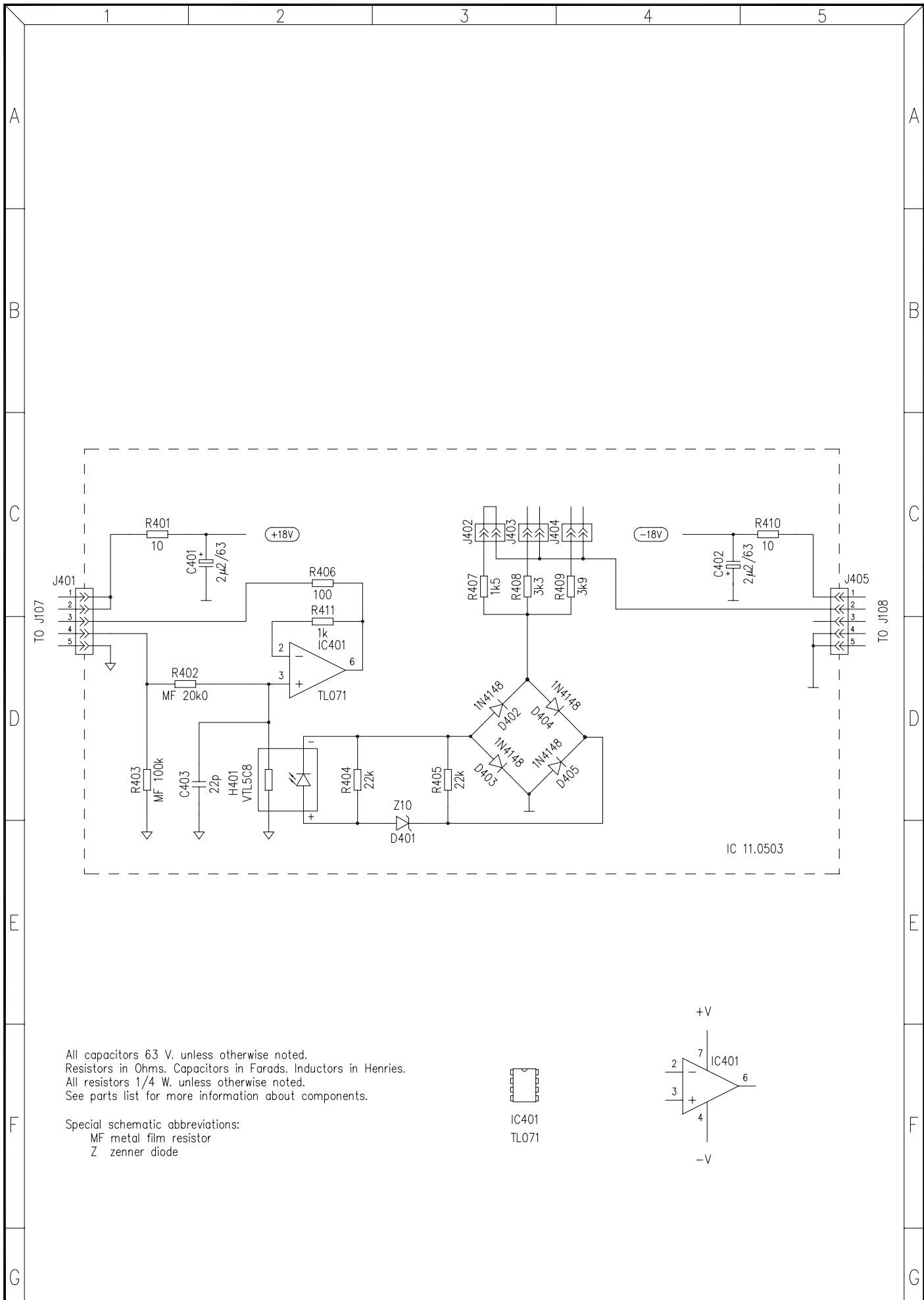

fig. 9





All capacitors 63 V. unless otherwise noted.
 Resistors in Ohms. Capacitors in Farads. Inductors in Henries.
 All resistors 1/4 W. unless otherwise noted.
 See parts list for more information about components.

Special schematic abbreviations:
 MF metal film resistor
 Z zener diode

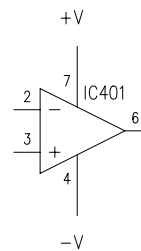

IC401
 TL071



TITLE: ANTICLIP CIRCUIT		MODEL: PAM1400/1000/600/300		 LABORATORIO DE ELECTRO-ACUSTICA BARCELONA ESPAÑA	
DRAWN: J.QUERALT		SHEET 4 OF 6			
DATE: 011093		REPLACES:		DRW. NO. 10.0232	
CHECKED: J.QUERALT		DATE: 040495		REV. A	
		REPLACED BY:			

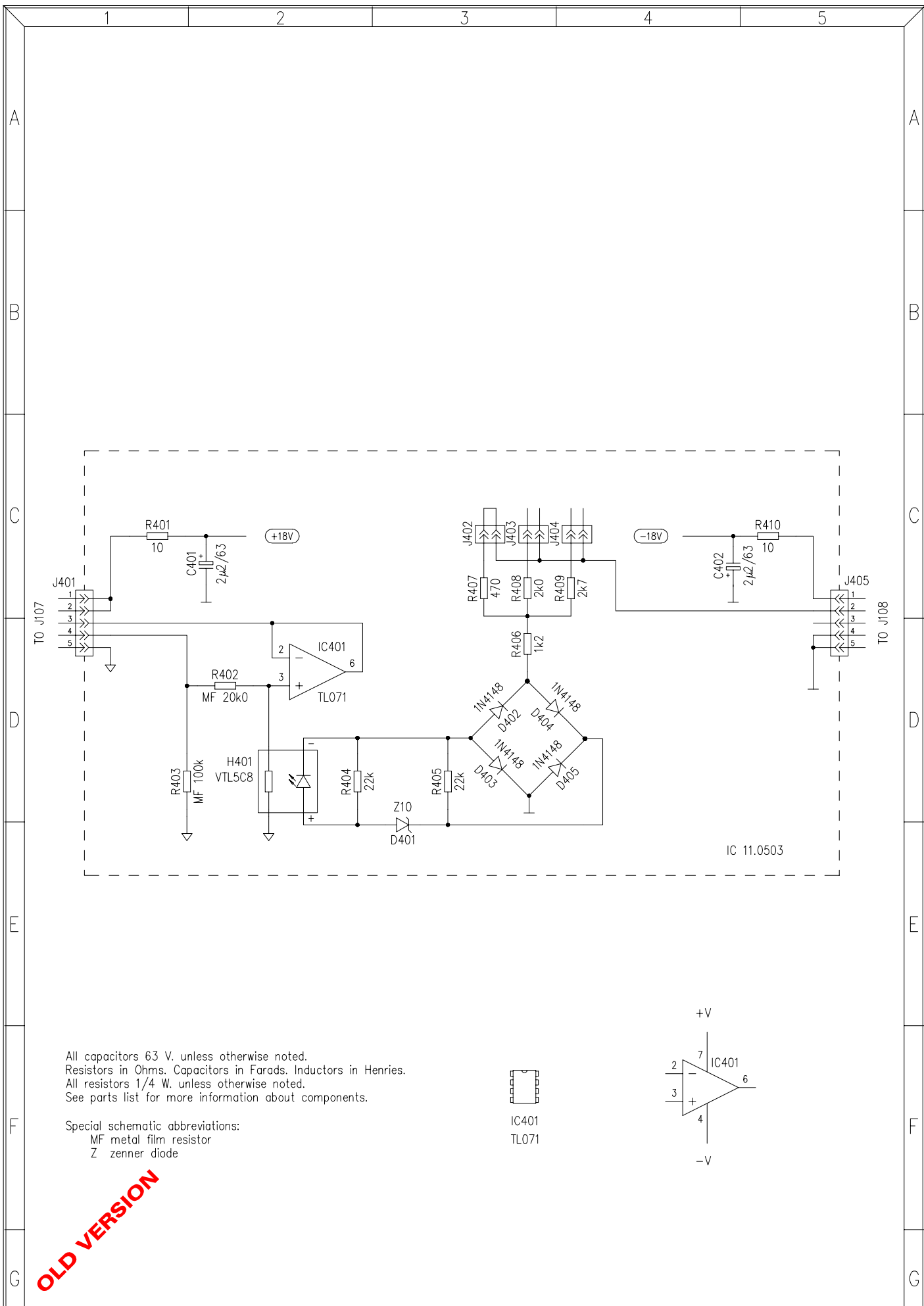

All capacitors 63 V. unless otherwise noted.
 Resistors in Ohms. Capacitors in Farads. Inductors in Henries.
 All resistors 1/4 W. unless otherwise noted.
 See parts list for more information about components.

Special schematic abbreviations:
 MF metal film resistor
 Z zener diode



IC401
 TL071

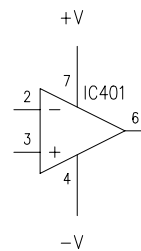

OLD VERSION

TITLE: ANTICLIP CIRCUIT		MODEL: PAM1400/1000/600/300	 LABORATORIO DE ELECTRO-ACUSTICA BARCELONA ESPAÑA	
		SHEET 4 OF 6		
DRAWN: J.QUERALT	DATE: 011093	REPLACES:	DRW. NO. 10.0232	REV.
CHECKED:	DATE:	REPLACED BY:		

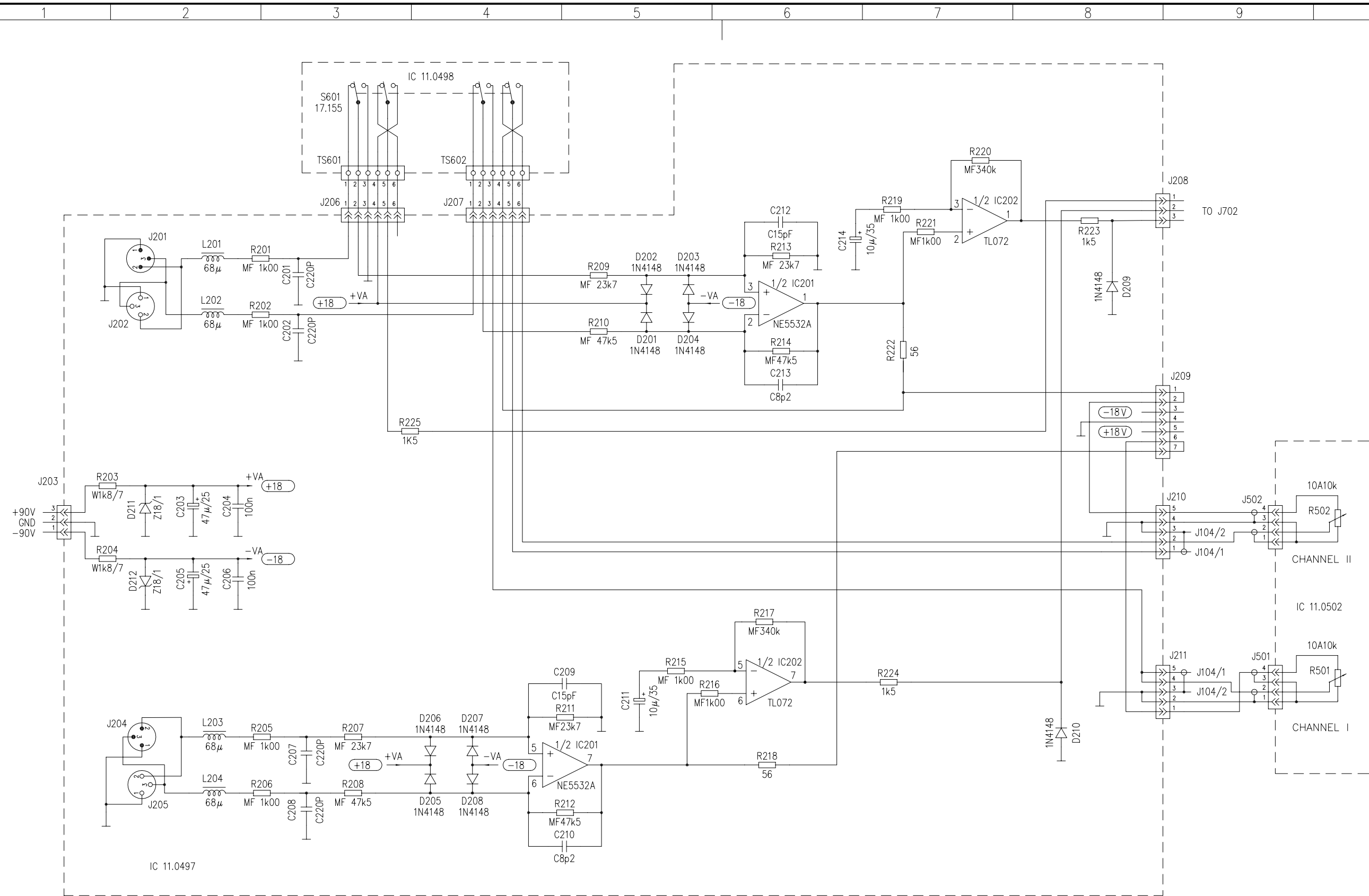

All capacitors 63 V, unless otherwise noted.
 Resistors in Ohms. Capacitors in Farads. Inductors in Henries.
 All resistors 1/4 W, unless otherwise noted.
 See parts list for more information about components.
 Part list specifies tolerance and power of the components.

Special schematic abbreviations:
 MF metal film resistor
 W wounded wire resistor
 NF non inflammable resistor
 T tantal capacitor
 C ceramic capacitor
 Z zener diode

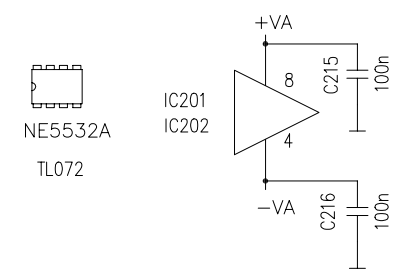

TITLE: INPUT CIRCUIT		MODEL: PAM1400/1000 Switching Power Mosfet Amplifier		 LABORATORIO DE ELECTRO-ACUSTICA BARCELONA ESPAÑA	
DRAWN: J.QUERALT		DATE: 300993			
CHECKED:		REPLACES:		DRW. NO. 10.0231	
DATE:		REPLACED BY:		REV.	

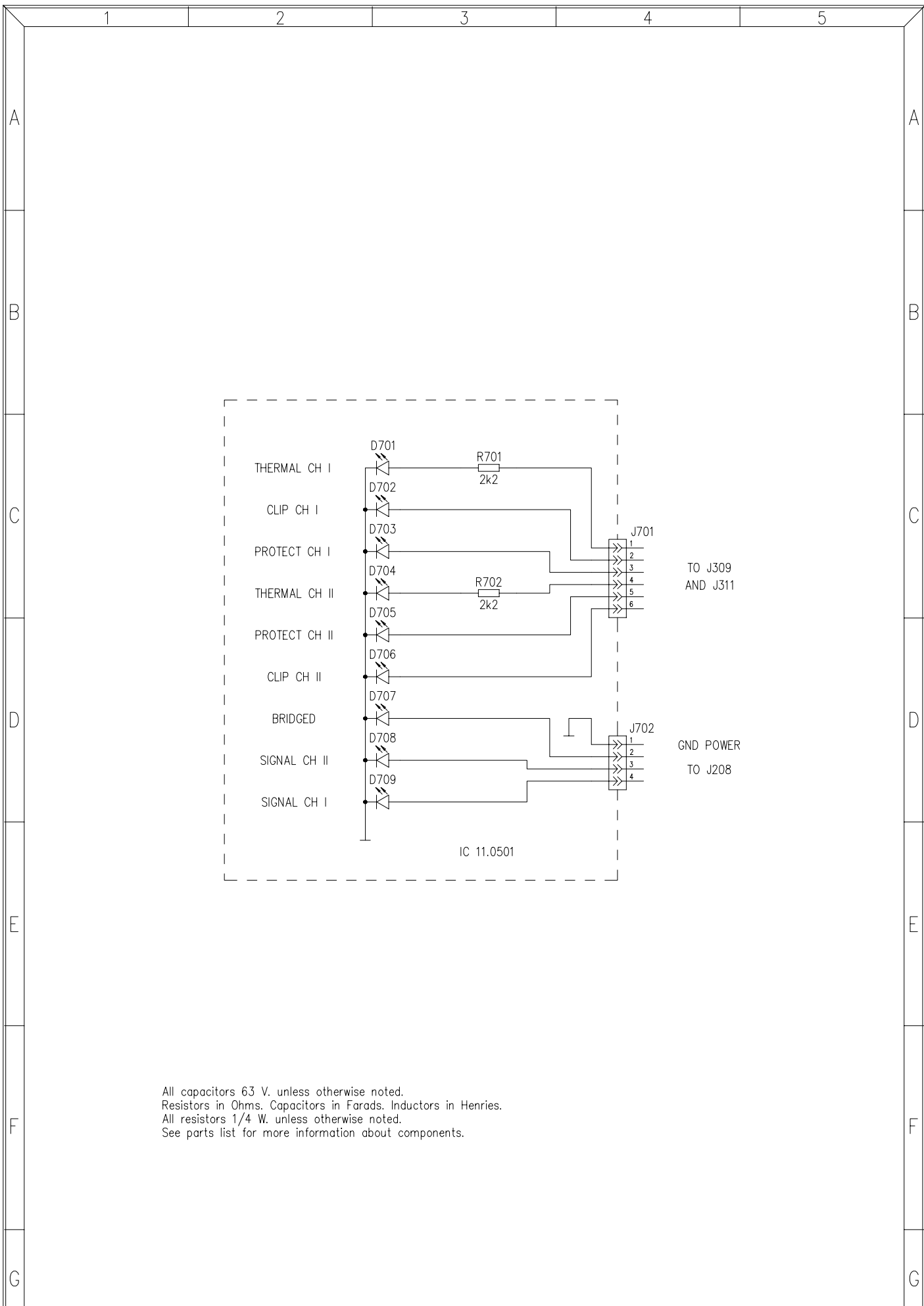

All capacitors 63 V. unless otherwise noted.
 Resistors in Ohms. Capacitors in Farads. Inductors in Henries.
 All resistors 1/4 W. unless otherwise noted.
 See parts list for more information about components.

TITLE: LEDS CIRCUIT		MODEL: PAM1400/1000/600/300		 LABORATORIO DE ELECTRO-ACUSTICA BARCELONA ESPAÑA	
		SHEET 5 OF 6			
DRAWN: J.QUERALT	DATE: 011093	REPLACES:		DRW. NO. 10.0233	REV.
CHECKED:	DATE:	REPLACED BY:			

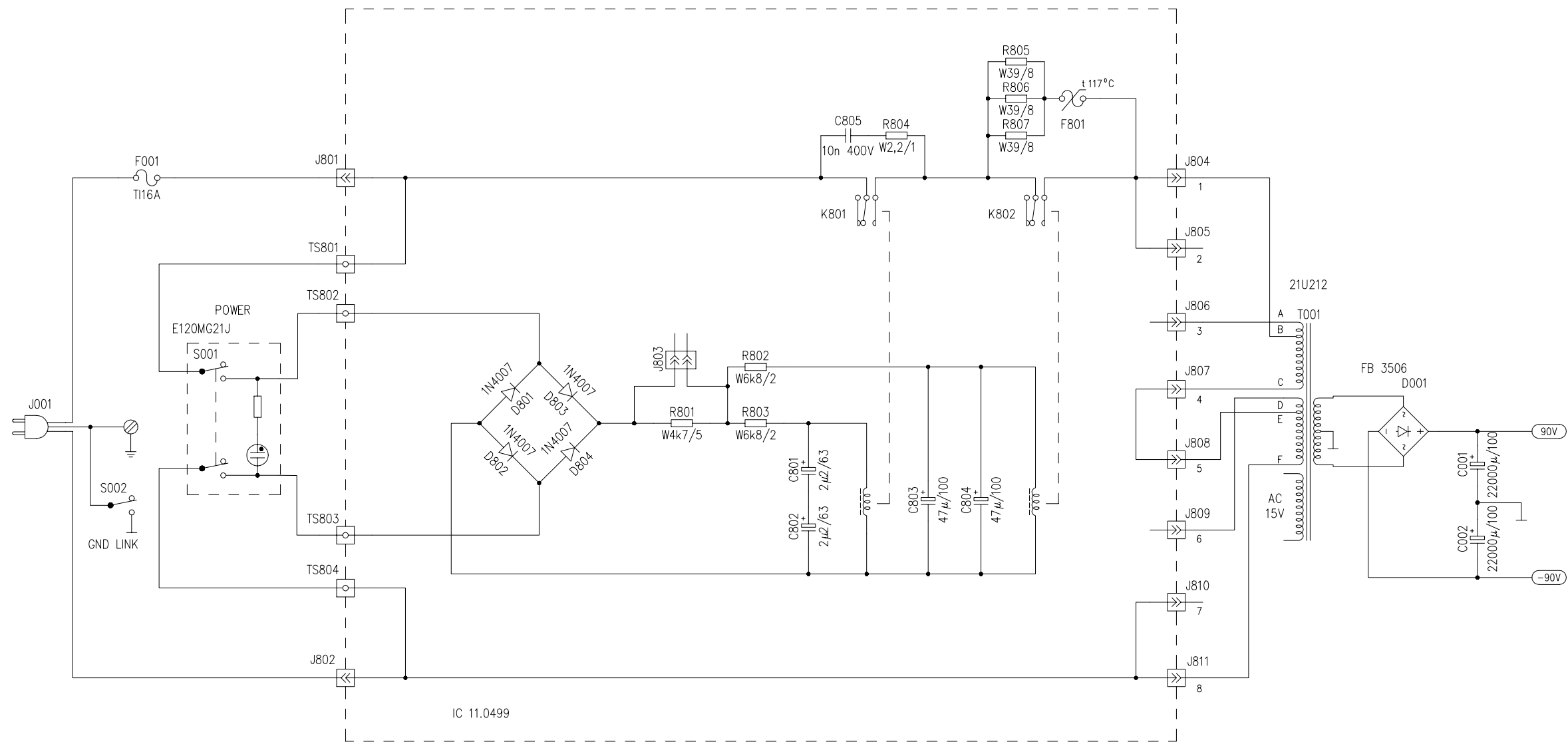

All capacitors 63 V, unless otherwise noted.
 Resistors in Ohms. Capacitors in Farads. Inductors in Henries.
 All resistors 1/4 W, unless otherwise noted.
 See parts list for more information about components.

Special schematic abbreviations:
 W wounded wire resistor
 C ceramic capacitor

110 V	120 V	220 V	230 V	240 V
1 - B	1 - A	1 - B	1 - A	1 - A
2 - E	2 - D	2 -	2 -	2 -
3 - A	3 - B	3 - A	3 - B	3 - B
4 -	4 -	4 - C	4 - C	4 - C
5 -	5 -	5 - E	5 - E	5 - D
6 - D	6 - E	6 - D	6 - D	6 - E
7 - C	7 - C	7 -	7 -	7 -
8 - F	8 - F	8 - F	8 - F	8 - F

MINI-JUMPER
 J803 ON

MINI-JUMPER
 J803 OFF

TITLE: SOFT START AND POWER CIRCUIT		MODEL: PAM1400		 LABORATORIO DE ELECTRO-ACUSTICA BARCELONA ESPAÑA	
DRAWN: J.QUERALT		DATE: 011093			
CHECKED:		DATE:		REPLACES:	
				REPLACED BY:	

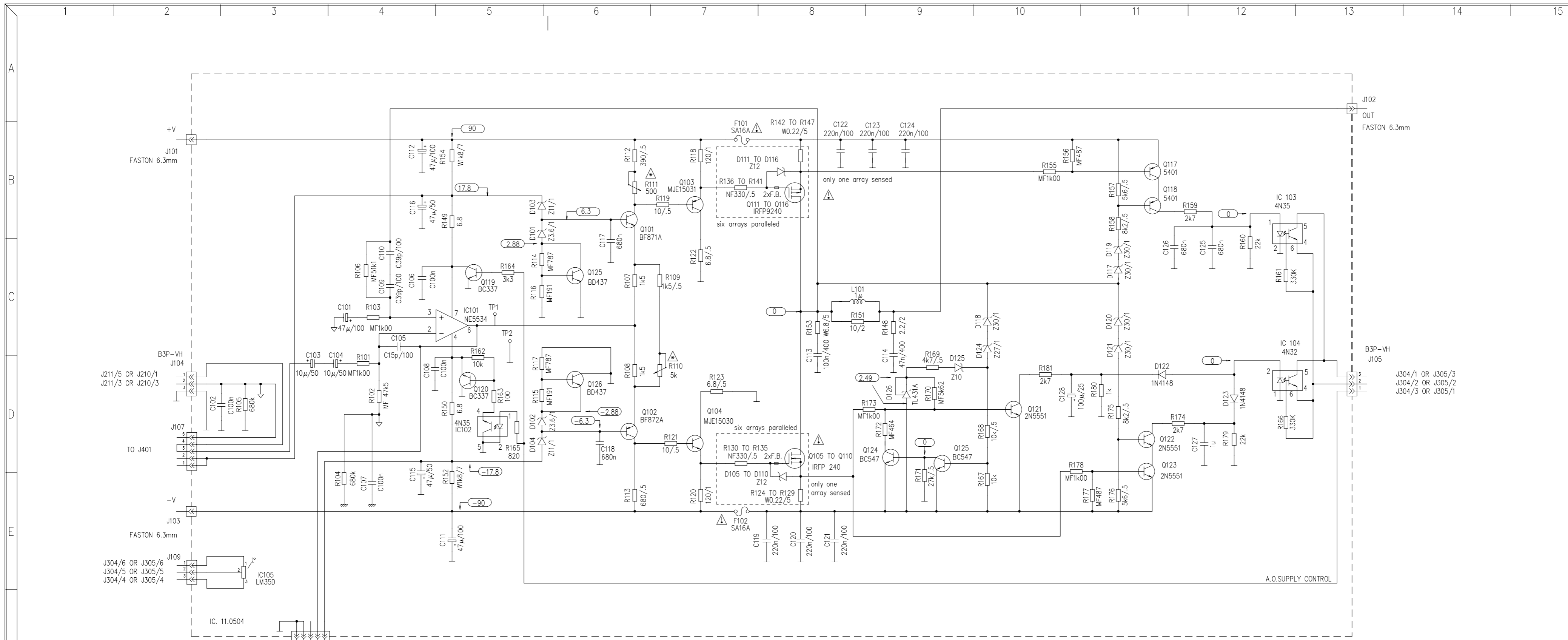

All capacitors 63 V, unless otherwise noted.
 Resistors in Ohms. Capacitors in Farads. Inductors in Henries.
 All resistors 1/4 W, unless otherwise noted.
 See parts list for more information about components.
 Part list specifies tolerance and power of the components.

Special schematic abbreviations:
 MF metal film resistor
 W wounded wire resistor
 NF non inflammable resistor
 T tantal capacitor
 C ceramic capacitor
 Z zener diode

▲ Factory adjusted.
 ▲ Critical component.

- 3 2 1
LM35D
- k a r
TL 431A
- c b e
2N5551
2N5401
- e b c
BC337
BC547B
- e c b
BD437
- e c b
BF871A
BF872A
- b c e
MJE15031
MJE15030
- G D S
IRFP 9240
IRFP 240
- TL112
4N32
- NE5534

TITLE: POWER CIRCUIT AND SHORT CIRCUIT PROTECTION SCHEMATIC DIAGRAM		MODEL: PAM 1400 Switching Mosfet Power Amplifier		 LABORATORIO DE ELECTRO-ACUSTICA ESPAÑA
DRAWN: J.QUERALT		SHEET 2 OF 6		
DATE: 300993	REPLACES:	DRW. NO. 10.230	REV. A	
CHECKED:	DATE:	REPLACED BY:		

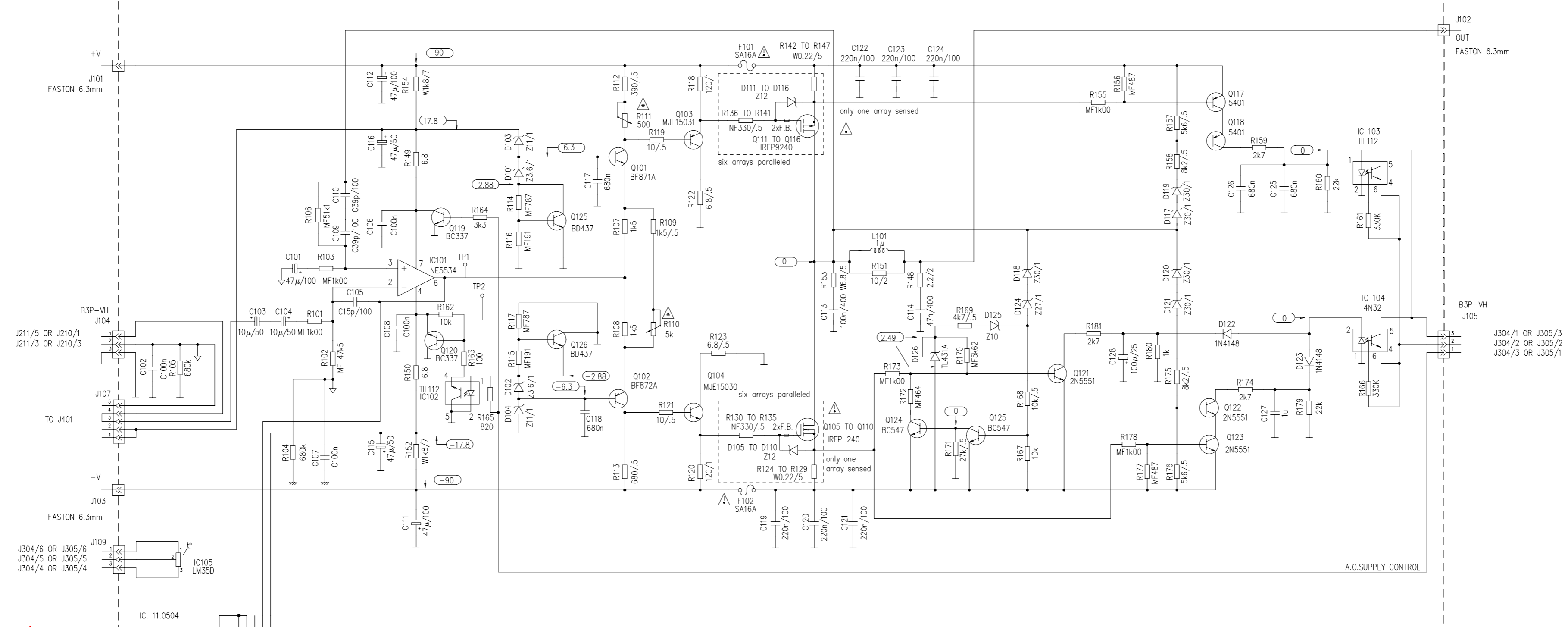

OLD VERSION

All capacitors 63 V, unless otherwise noted.
Resistors in Ohms. Capacitors in Farads. Inductors in Henries.
All resistors 1/4 W, unless otherwise noted.
See parts list for more information about components.
Part list specifies tolerance and power of the components.

Special schematic abbreviations:
MF metal film resistor
W wounded wire resistor
NF non inflammable resistor
T tantal capacitor
C ceramic capacitor
Z zener diode

⚠ Factory adjusted.
⚠ Critical component.

- 3 2 1
LM35D
- k a r
TL 431A
- c b e
2N5551
2N5401
- e b c
BC337
BC547B
- e c b
BD437
- e c b
BF871A
BF872A
- b c e
MJE15031
MJE15030
- G D S
IRFP 9240
IRFP 240
- TIL112
4N32
- NE5534

TITLE: POWER CIRCUIT AND SHORT CIRCUIT PROTECTION SCHEMATIC DIAGRAM		MODEL: PAM 1400 Switching Mosfet Power Amplifier		 LABORATORIO DE ELECTRO-ACUSTICA ESPAÑA
DRAWN: J.QUERALT		SHEET 2 OF 6		
DATE: 300993		REPLACES:		DRW. NO. 10.230
CHECKED:		REPLACED BY:		REV.

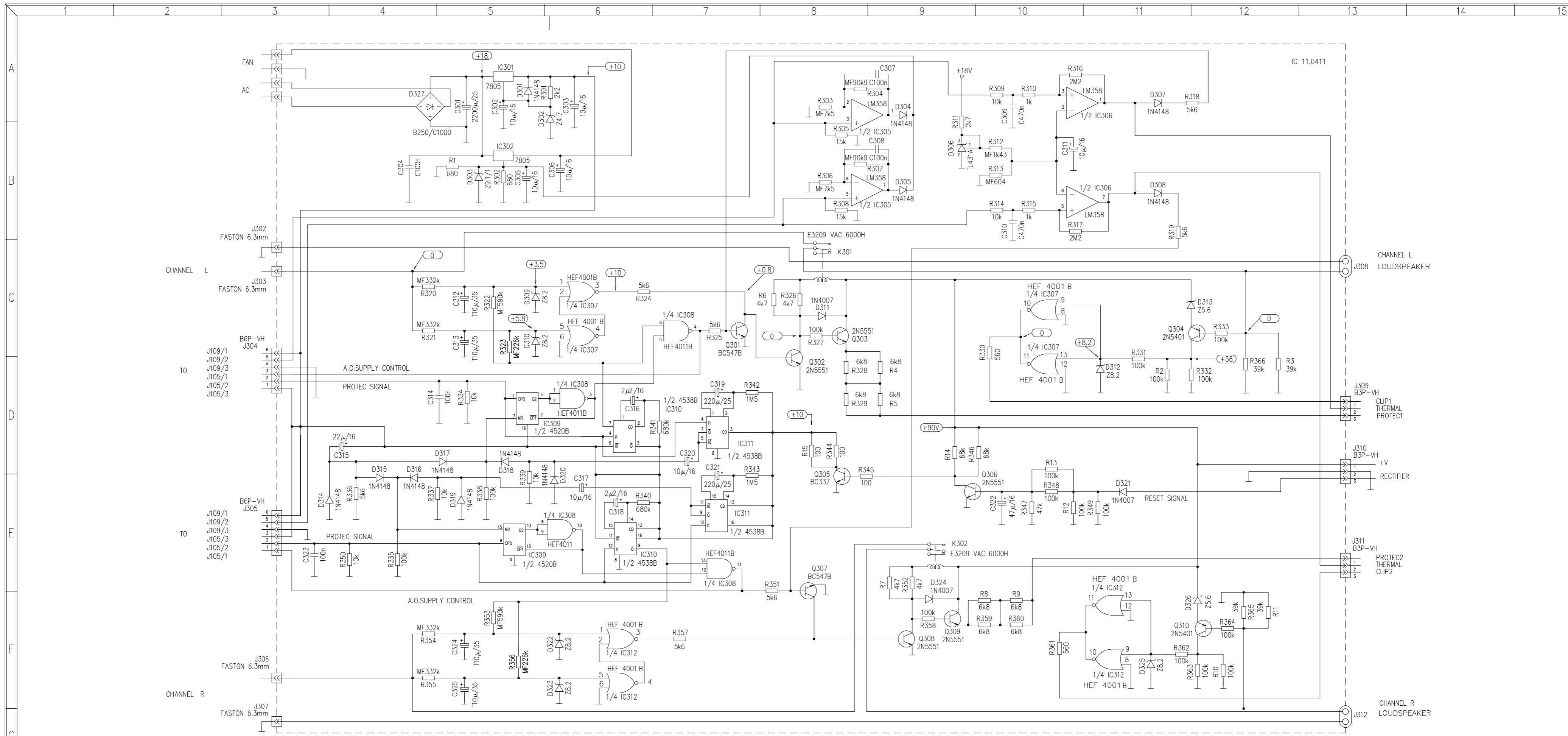

TITLE: PROTECTIONS CIRCUIT
 DRAWN: J.QUERALT
 CHECKED:

MODEL: PAM 1400
 Switching Power Mosfet Amplifier
 SHEET: 6 OF 6
 REPLACES:
 REPLACED BY:

ECLEROO
 LABORATORIO DE ELECTRO-ACUSTICA
 BARCELONA ESPAÑA
 DRW. NO. 10.0236
 REV.

All capacitors 63 V, unless otherwise noted.
 Resistors in Ohms, Capacitors in Farads, Inductors in Henries.
 All resistors 1/4 W, unless otherwise noted.
 See parts list for more information about components.
 Part list specifies tolerance and power of the components.

Special schematic abbreviations:
 MF metal film resistor 1%
 W wounded wire resistor
 T tantal capacitor
 C ceramic capacitor
 Z zener diode

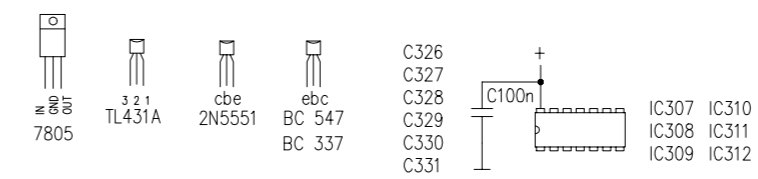

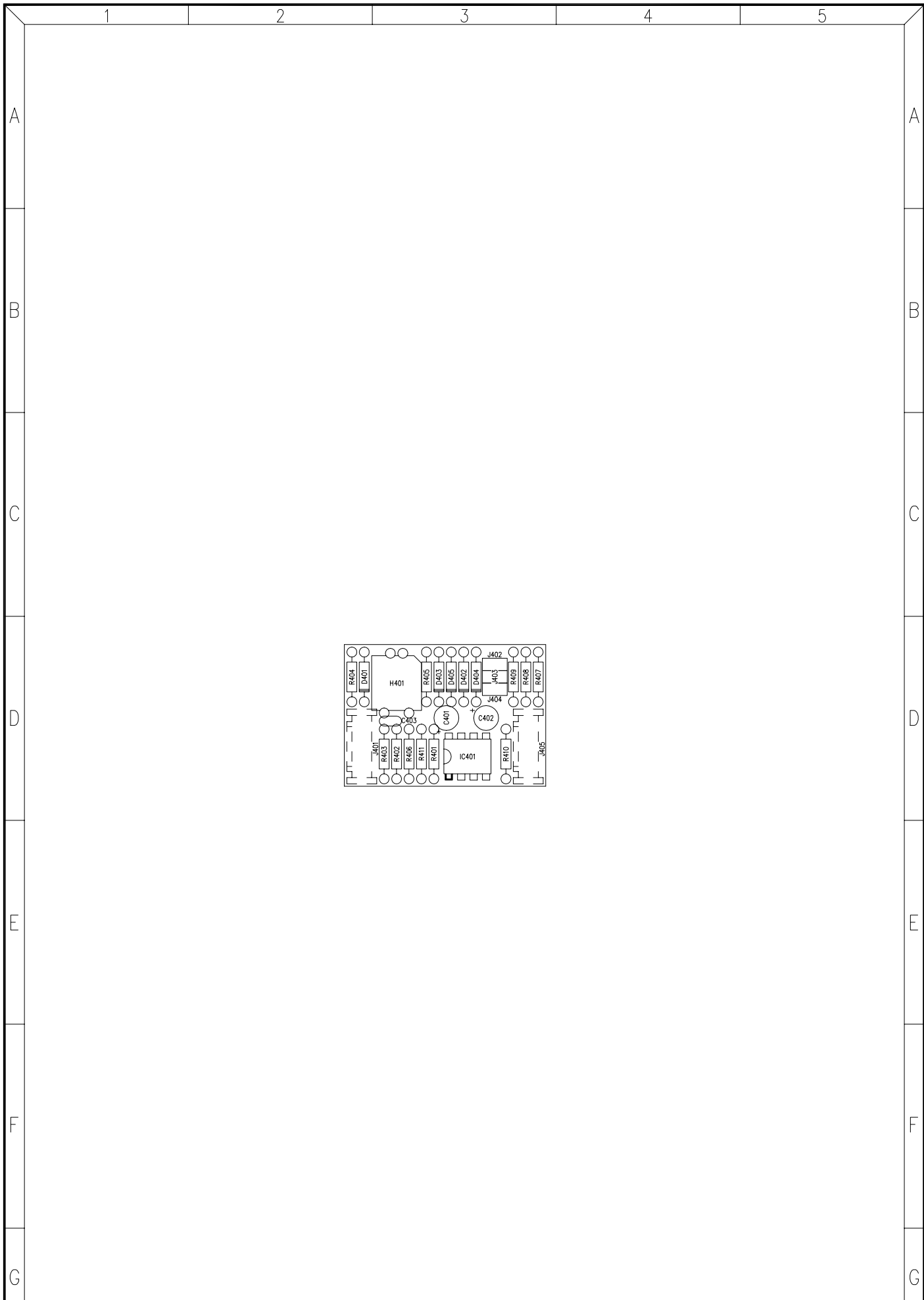

TITLE: ANTICLIP CIRCUIT		MODEL: PAM1400/1000/600/300		 LABORATORIO DE ELECTRO-ACUSTICA BARCELONA ESPAÑA	
		SHEET 4 OF 7			
DRAWN: J.QUERALT	DATE: 180595	REPLACES:		DRW. NO.	REV.
CHECKED:	DATE:	REPLACED BY:		33.0004 R/	A

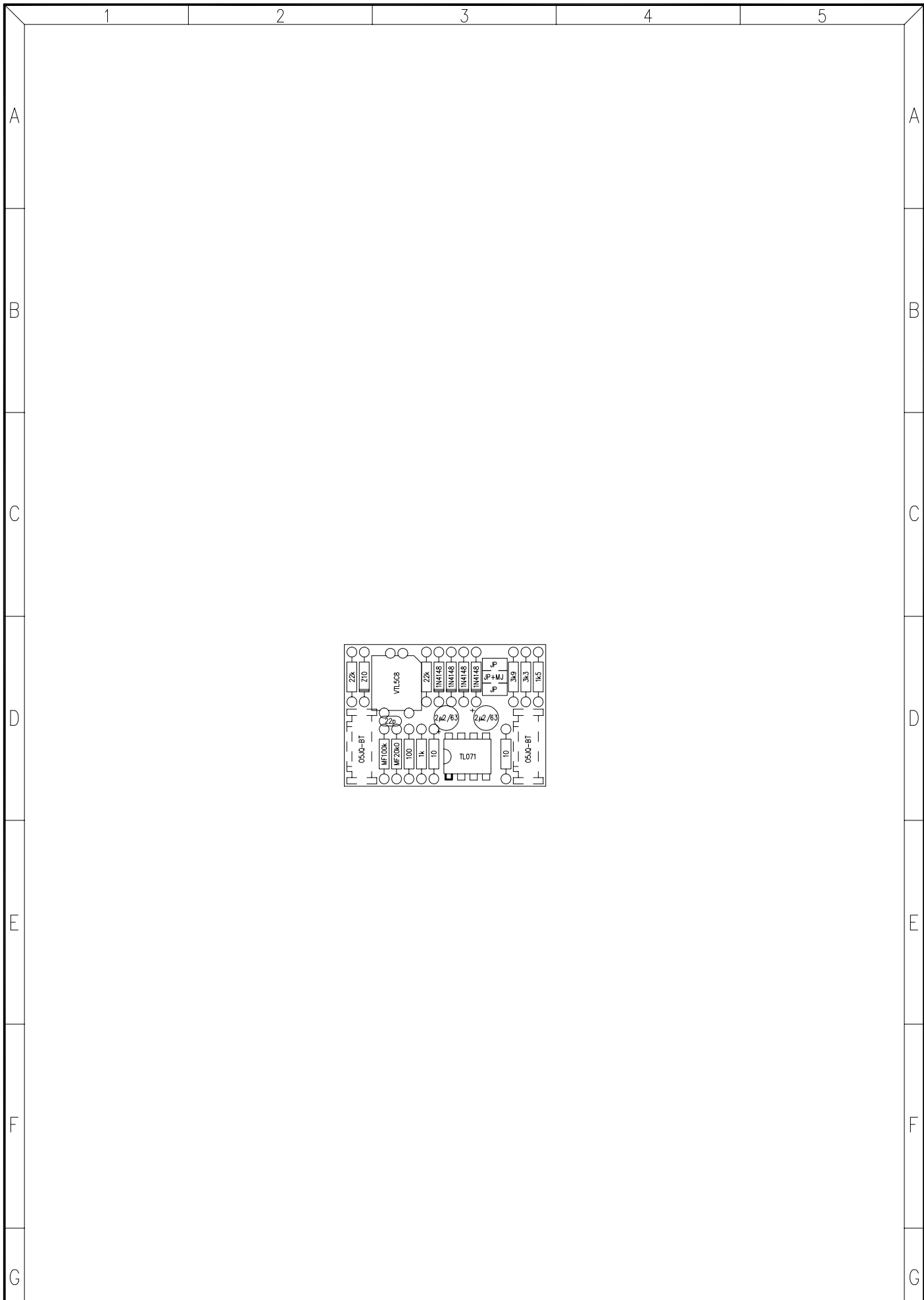

TITLE: ANTICLIP CIRCUIT		MODEL: PAM1400/1000/600/300		 LABORATORIO DE ELECTRO-ACUSTICA BARCELONA ESPAÑA	
		SHEET 4 OF 7			
DRAWN: J.QUERALT	DATE: 180595	REPLACES:		DRW. NO. 33.0004 v/	REV. A
CHECKED:	DATE:	REPLACED BY:			

PARTS LIST:
MODEL : PAM1400/1000/600/300
DATE: 180595

ANTICLIP CIRCUIT
DRW. No 33.0004PL
SHEET 1 OF 1 REPLACES:

REV: A
REPLACED BY:

REFERENCE	VALUE
C401	2 μ 2/63
C402	2 μ 2/63
C403	22pF
D401	Z10
D402	1N4148
D403	1N4148
D404	1N4148
D405	1N4148
H401	VTL5C8
IC401	TL071
J401	O5JQ-BT
J402	JP
J403	JP+MJ
J404	JP
J405	O5JQ-BT
R401	10 Ω
R402	MF20k0
R403	MF100k
R404	22k
R405	22k
R406	100 Ω
R407	1k5
R408	3k3
R409	3k9
R410	10 Ω
R411	1k
PC 11.0503B	PRINTED CIRCUIT

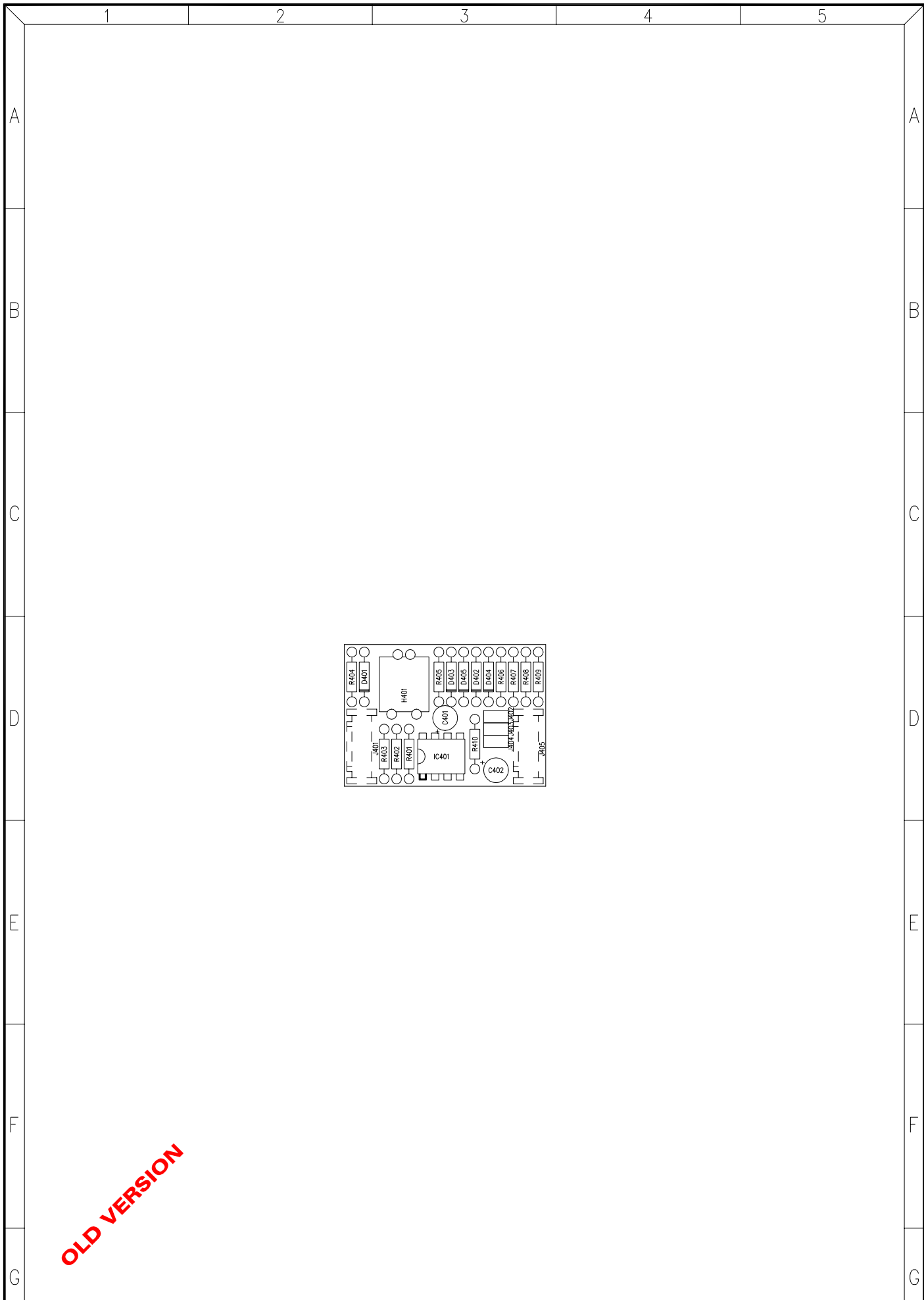

OLD VERSION

TITLE: ANTICLIP CIRCUIT		MODEL: PAM1400/1000/600/300		 LABORATORIO DE ELECTRO-ACUSTICA BARCELONA ESPAÑA	
		SHEET 4 OF 7			
DRAWN: J.QUERALT	DATE: 081193	REPLACES:		DRW. NO.	REV.
CHECKED:	DATE:	REPLACED BY:		33.0004 R/	

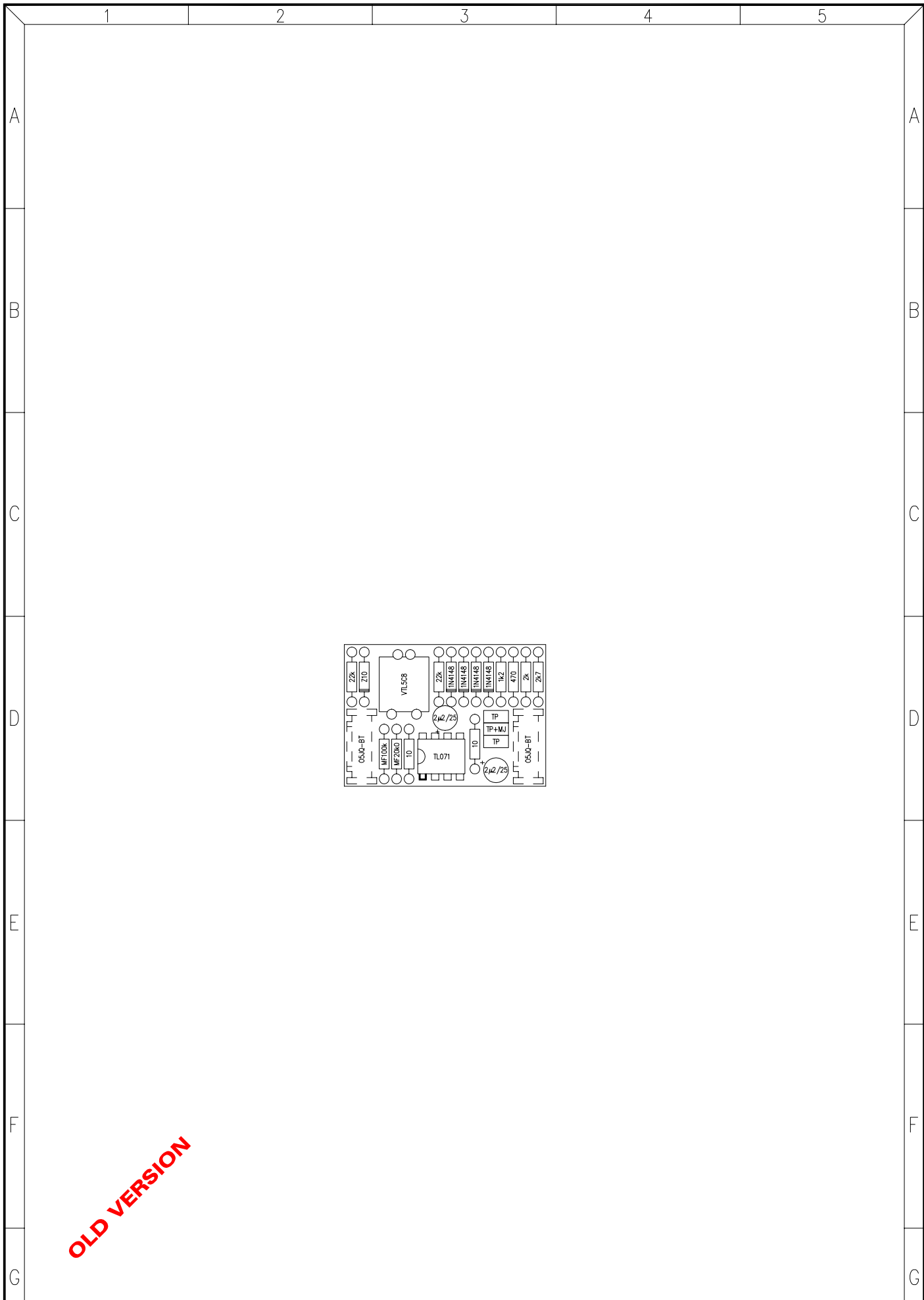

OLD VERSION

TITLE: ANTICLIP CIRCUIT		MODEL: PAM1400/1000/600/300		 LABORATORIO DE ELECTRO-ACUSTICA BARCELONA ESPAÑA	
		SHEET 4 OF 7			
DRAWN: J.QUERALT	DATE: 081193	REPLACES:		DRW. NO. 33.0004 v/	REV.
CHECKED:	DATE:	REPLACED BY:			

PARTS LIST:
MODEL : PAM1400/1000/600/300
DATE: 081193

ANTICLIP CIRCUIT
DRW. No 33.0004PL
SHEET 1 OF 1 REPLACES:

REV:
REPLACED BY:

REFERENCE	VALUE
C401	2 μ 2/63
C402	2 μ 2/63
D401	Z10
D402	1N4148
D403	1N4148
D404	1N4148
D405	1N4148
H401	VTL5C8
IC401	TL071
J401	O5JQ-BT
J402	TP
J403	TP+MJ
J404	TP
J405	O5JQ-BT
R401	10 Ω
R402	MF20k0
R403	MF100k
R404	22k
R405	22k
R406	1k2
R407	470 Ω
R408	2k
R409	2k7
R410	10 Ω
PC 11.0503	PRINTED CIRCUIT

OLD VERSION

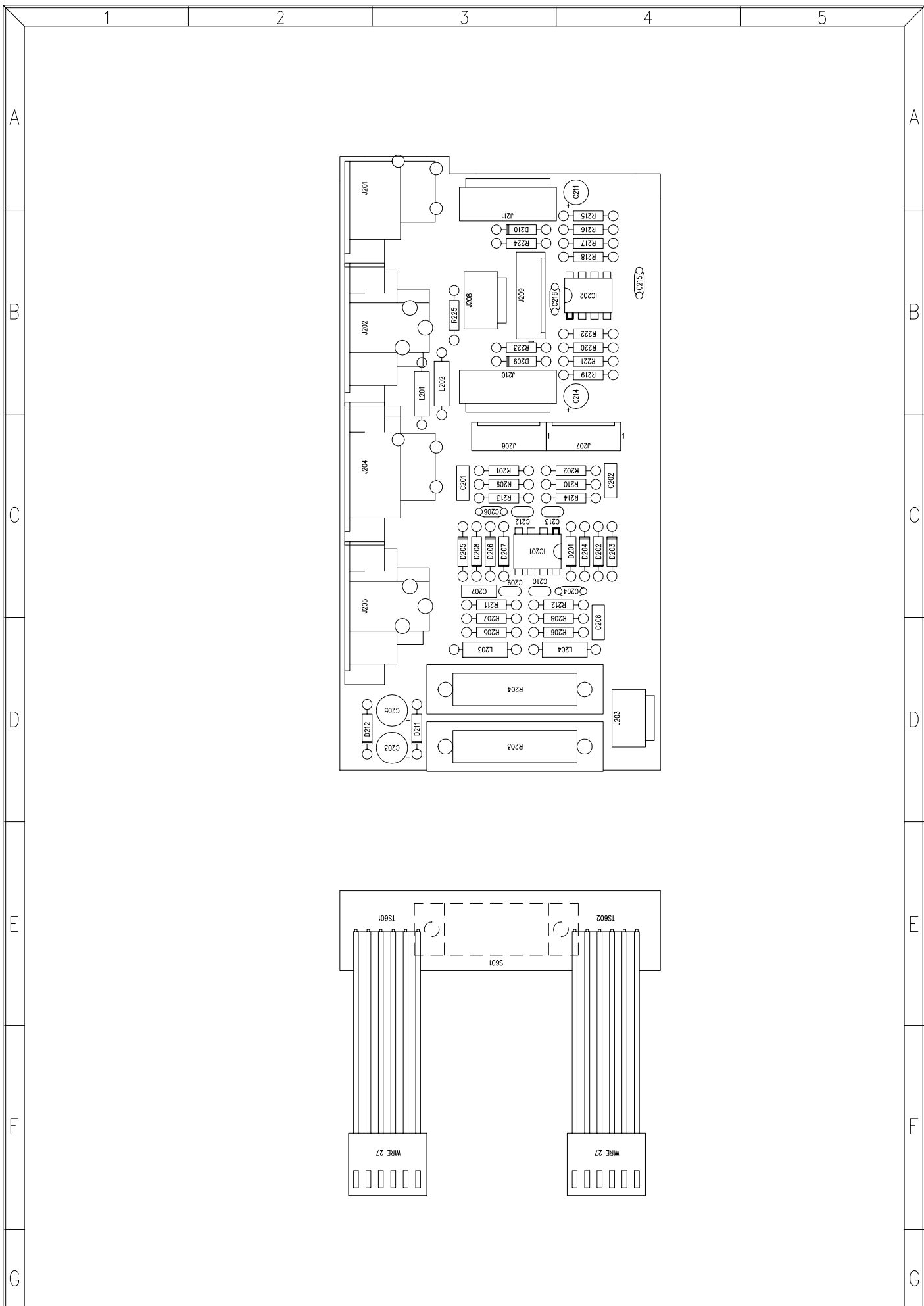

TITLE: INPUT CIRCUIT		MODEL: PAM1400/1000	 LABORATORIO DE ELECTRO-ACUSTICA BARCELONA ESPAÑA	
		SHEET 2 OF 7		
DRAWN: J.QUERALT	DATE: 081193	REPLACES:	DRW. NO. 33.0002 R/	REV.
CHECKED:	DATE:	REPLACED BY:		

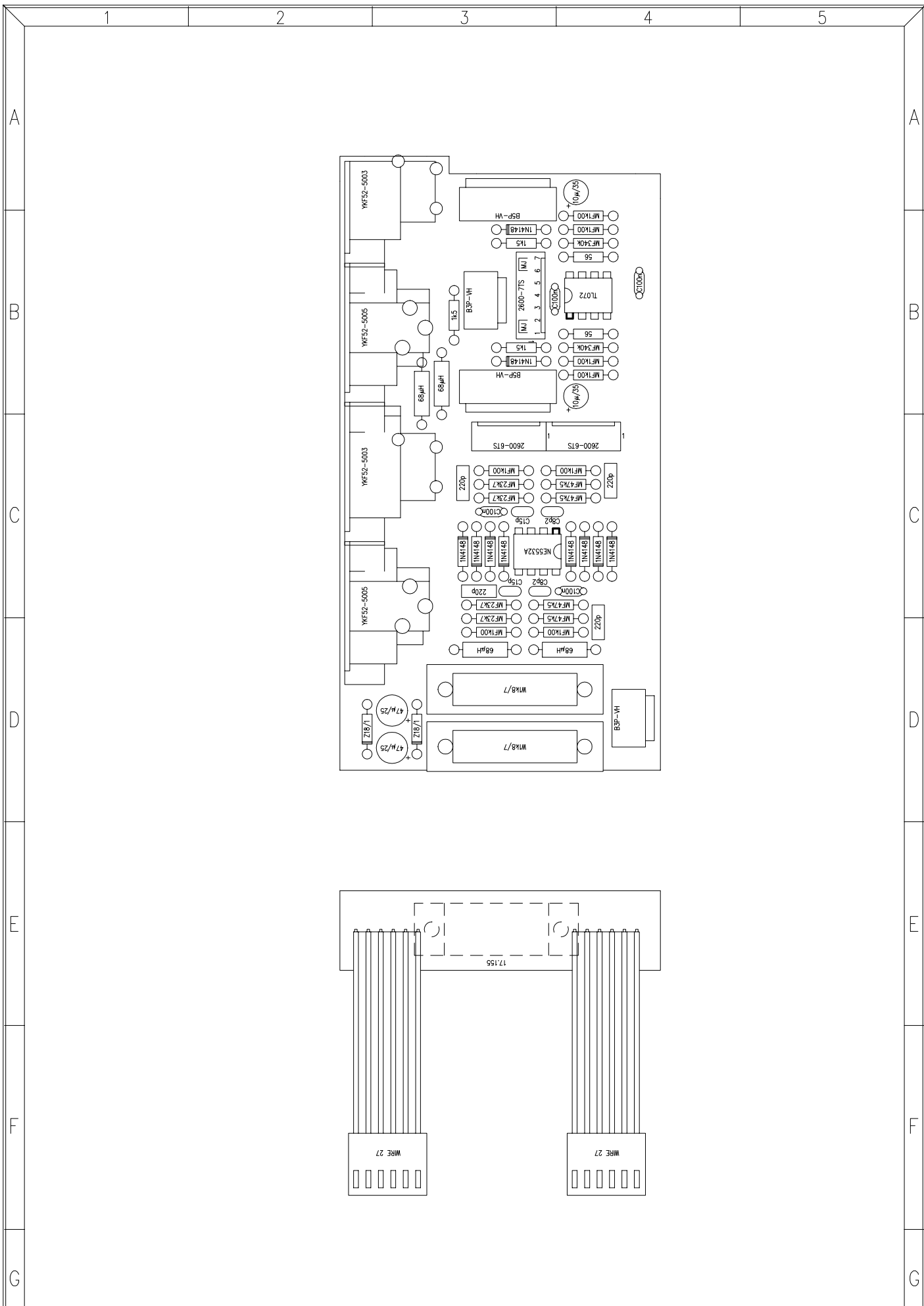

TITLE: INPUT CIRCUIT		MODEL: PAM1400/1000	 LABORATORIO DE ELECTRO-ACUSTICA BARCELONA ESPAÑA	
		SHEET 2 OF 7		
DRAWN: J.QUERALT	DATE: 081193	REPLACES:	DRW. NO.	REV.
CHECKED:	DATE:	REPLACED BY:	33.0002 v/	

PARTS LIST:
MODEL : PAM1400/1000
DATE: 081193

INPUT CIRCUIT
DRW. No 33.0002PL
SHEET 1 OF 2 REPLACES:

REV:
REPLACED BY:

REFERENCE	VALUE
C201	220p
C202	220p
C203	47 μ /25
C204	C100n
C205	47 μ /25
C206	C100n
C207	220p
C208	220p
C209	C15p
C210	C8p2
C211	10 μ /35
C212	C15p
C213	C8p2
C214	10 μ /35
C215	C100n
C216	C100n
D201	1N4148
D202	1N4148
D203	1N4148
D204	1N4148
D205	1N4148
D206	1N4148
D207	1N4148
D208	1N4148
D209	1N4148
D210	1N4148
D211	Z18/1
D212	Z18/1
IC201	NE5532A
IC202	TL072
J201	YKF52-5003
J202	YKF52-5005
J203	B3P-VH
J204	YKF52-5003
J205	YKF52-5005
J206	2600-6TS
J207	2600-6TS
J208	B3P-VH
J209	2600-7TS
J210	B5P-VH
J211	B5P-VH
L201	68 μ H
L202	68 μ H
L203	68 μ H
L204	68 μ H
R201	MF1k00
R202	MF1k00
R203	W1k8/7
R204	W1k8/7
R205	MF1k00
R206	MF1k00
R207	MF23k7
R208	MF47k5
R209	MF23k7
R210	MF47k5
R211	MF23k7

PARTS LIST:
MODEL : PAM1400/1000
DATE: 081193

INPUT CIRCUIT
DRW. No 33.0002PL
SHEET 2 OF 2 REPLACES:

REV:
REPLACED BY:

REFERENCE	VALUE
R212	MF47k5
R213	MF23k7
R214	MF47k5
R215	MF1k00
R216	MF1k00
R217	MF340k
R218	56
R219	MF1k00
R220	MF340k
R221	MF1k00
R222	56
R223	1k5
R224	1k5
R225	1k5
S601	17.155
WIRE 27	WIRE 27
WIRE 27	WIRE 27
CTO 11.0497-8	CTO.FRA.CU.

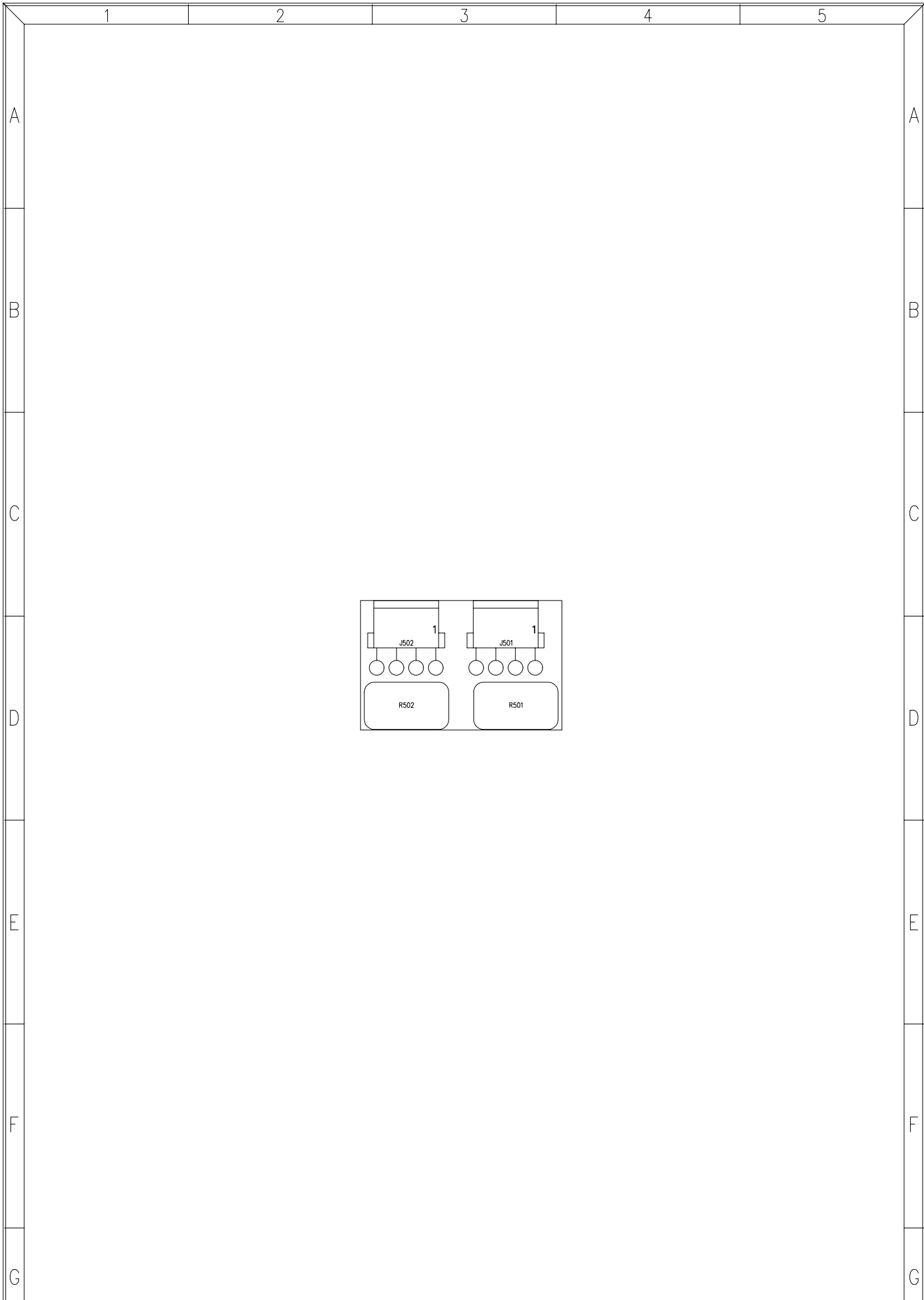

TITLE: ATTENUATOR CIRCUIT		MODEL: PAM1400/1000/600/300		 LABORATORIO DE ELECTRO-ACUSTICA BARCELONA ESPAÑA	
		SHEET 3 OF 6			
DRAWN: J.QUERALT	DATE: 081193	REPLACES:		DRW. NO.	REV.
CHECKED:	DATE:	REPLACED BY:		33.0003R/	

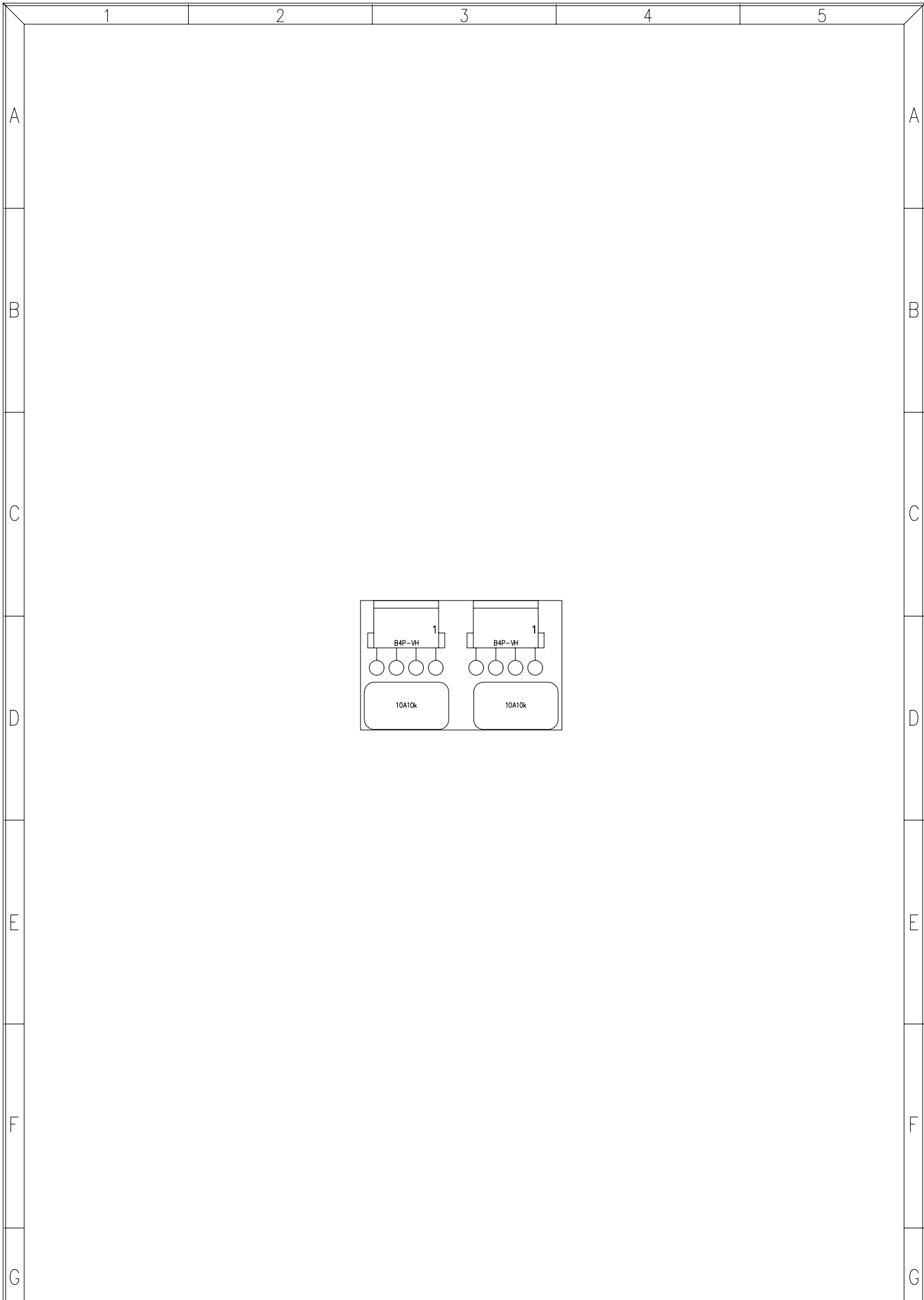

TITLE: ATTENUATOR CIRCUIT		MODEL: PAM1400/1000/600/300		 LABORATORIO DE ELECTRO-ACUSTICA BARCELONA ESPAÑA	
		SHEET 3 OF 6			
DRAWN: J.QUERALT	DATE: 081193	REPLACES:		DRW. NO. 33.0003	REV. V/
CHECKED:	DATE:	REPLACED BY:			

PARTS LIST:
MODEL : PAM1400/1000/600/300
DATE: 081193

ATTENUATOR CIRCUIT
DRW. No 33.0003PL
SHEET 1 OF 1 REPLACES:

REV:
REPLACED BY:

REFERENCE

VALUE

J501	B4P-S-VH
J502	B4P-S-VH
R501	10A10k
R502	10A10k
CTO 11.0502	CTO.FRA.CU.

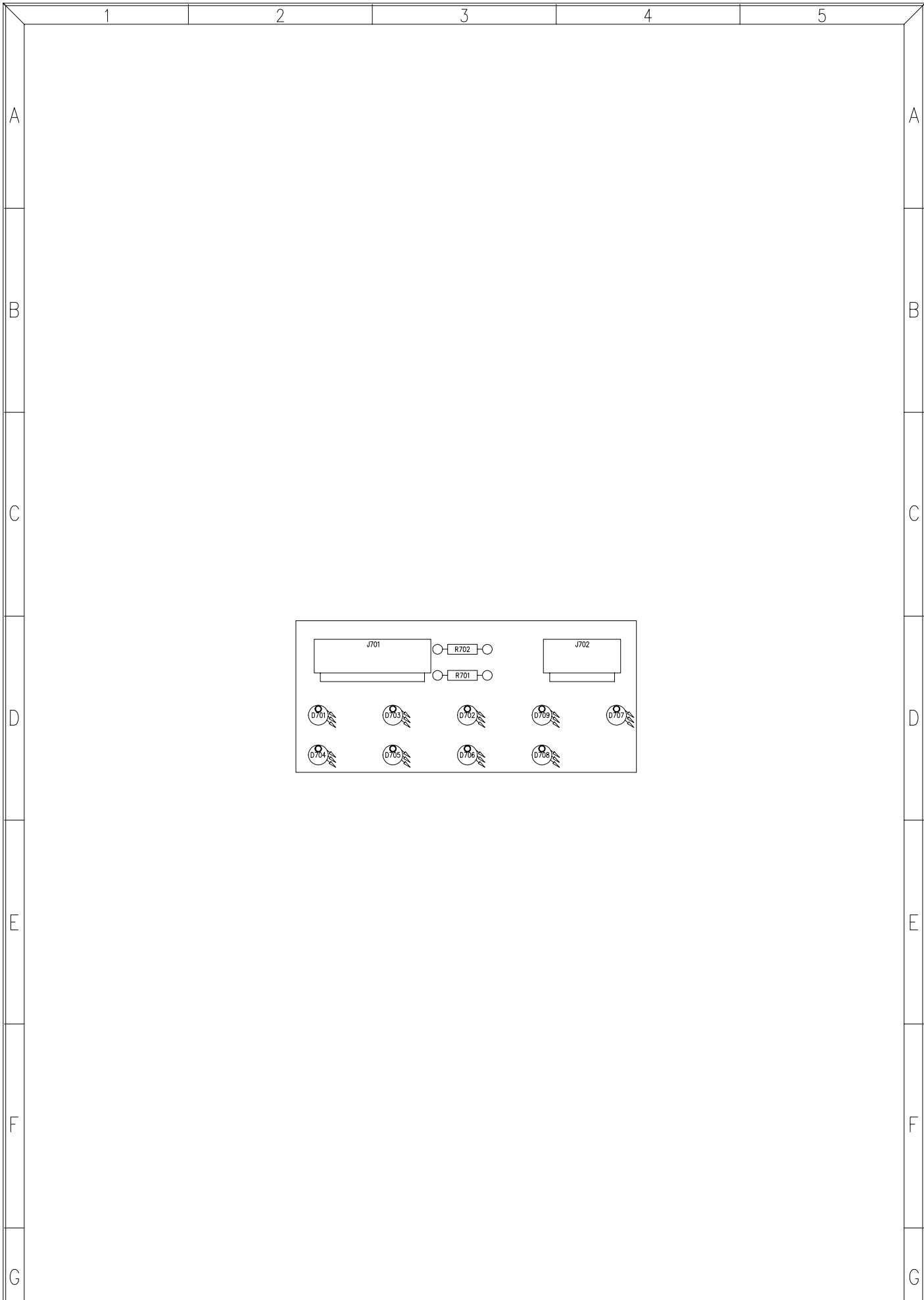

TITLE: LEDS CIRCUIT		MODEL: PAM1400/1000/600/300		 LABORATORIO DE ELECTRO-ACUSTICA BARCELONA ESPAÑA	
		SHEET 5 OF 7			
DRAWN: J.QUERALT	DATE: 081193	REPLACES:		DRW. NO.	REV.
CHECKED:	DATE:	REPLACED BY:		33.0005 R/	

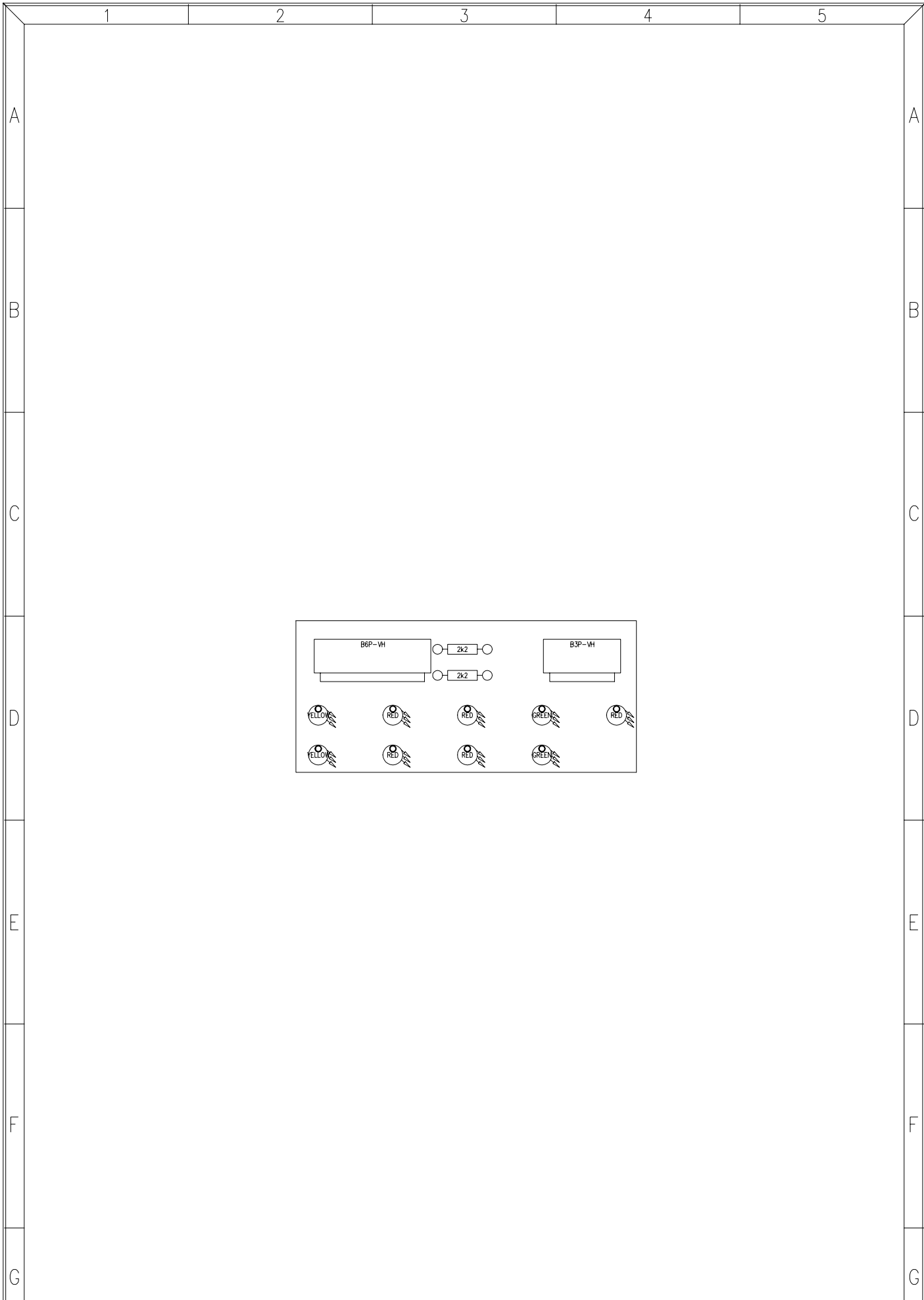

TITLE: LEDS CIRCUIT		MODEL: PAM1400/1000/600/300		ECLEREO	
		SHEET 5 OF 7		LABORATORIO DE ELECTRO-ACUSTICA BARCELONA ESPAÑA	
DRAWN: J.QUERALT	DATE: 081193	REPLACES:		DRW. NO. 33.0005	REV. V/
CHECKED:	DATE:	REPLACED BY:			

PARTS LIST:
MODEL : PAM1400/1000/600/300
DATE: 081193

LEDS CIRCUIT
DRW. No 33.0005PL
SHEET 1 OF 1 REPLACES:

REV:
REPLACED BY:

REFERENCE	VALUE
D701	YELLOW
D702	RED
D703	RED
D704	YELLOW
D705	RED
D706	RED
D707	RED
D708	GREEN
D709	GREEN
J701	B6P-VH
J702	B3P-VH
R701	2k2
R702	2k2
CTO 11.0501	CTO.FRA.CU.

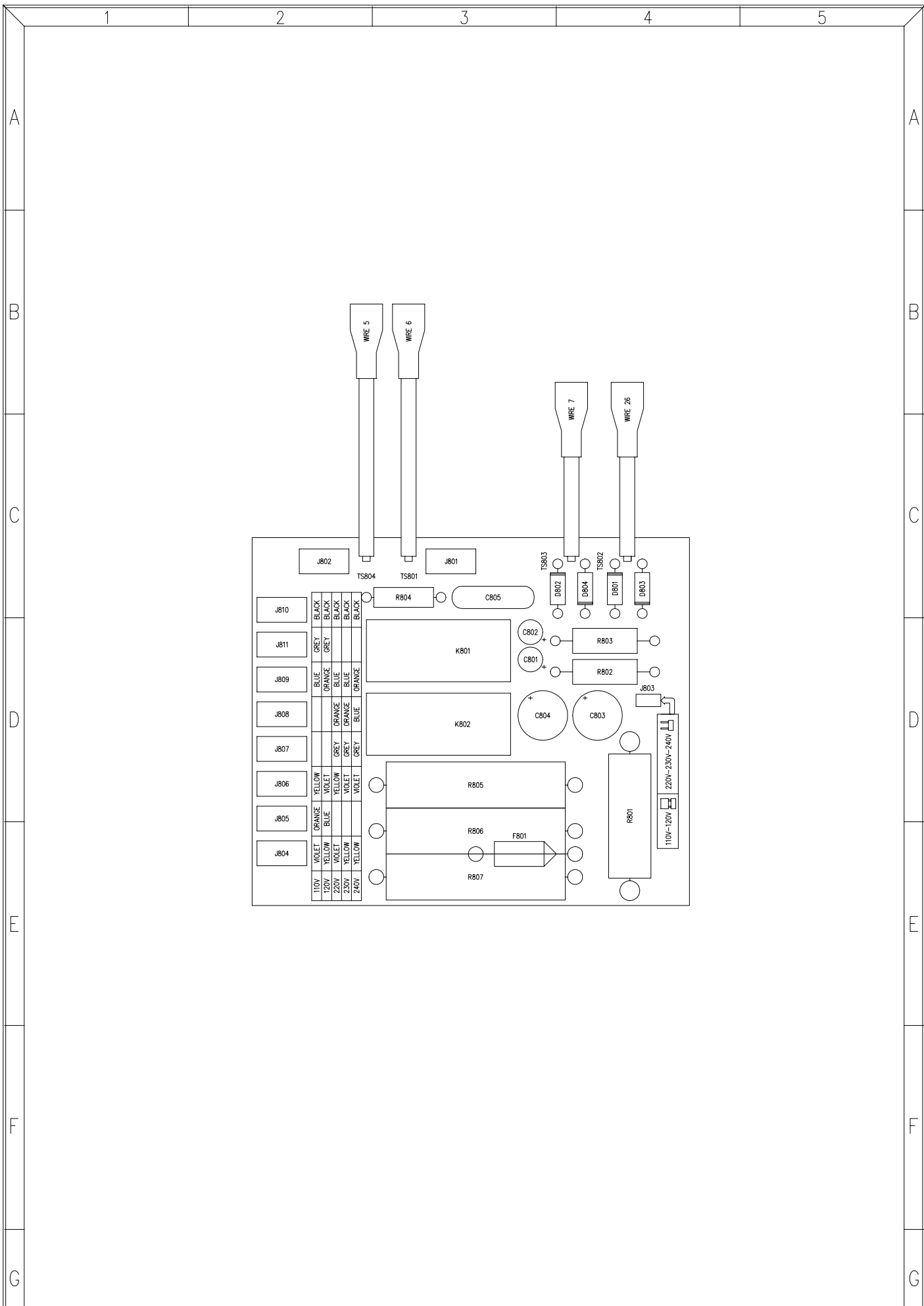

TITLE: SOFT START AND POWER CIRCUIT		MODEL: PAM1400/1000		 LABORATORIO DE ELECTRO-ACUSTICA BARCELONA ESPAÑA	
		SHEET 6 OF 7			
DRAWN: J.QUERALT	DATE: 081193	REPLACES:		DRW. NO. 33.0006 R/	REV.
CHECKED:	DATE:	REPLACED BY:			

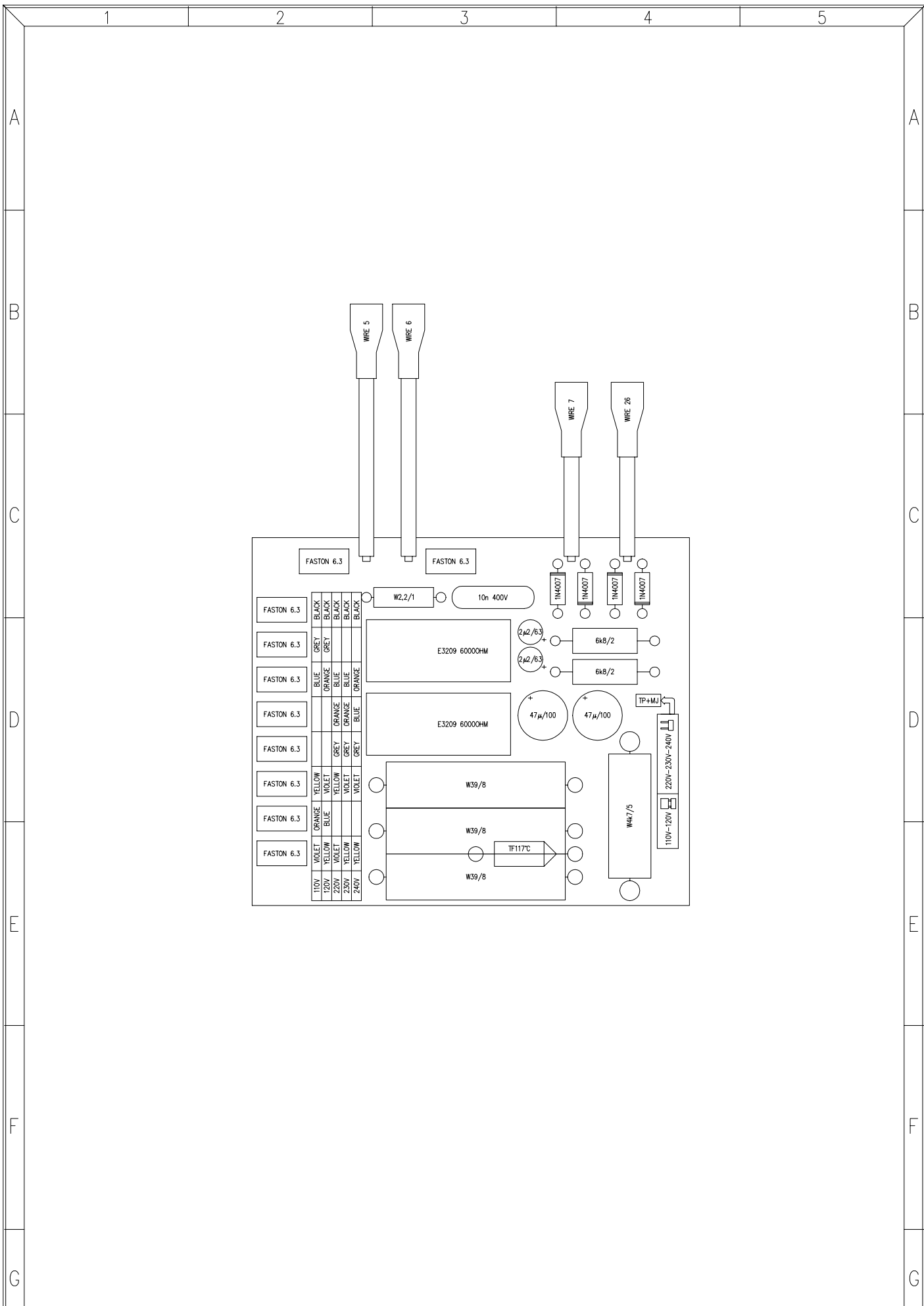

TITLE: SOFT START AND POWER CIRCUIT		MODEL: PAM1400/1000		 LABORATORIO DE ELECTRO-ACUSTICA BARCELONA ESPAÑA	
		SHEET 6 OF 7			
DRAWN: J.QUERALT	DATE: 081193	REPLACES:		DRW. NO. 33.0006	REV. v/
CHECKED:	DATE:	REPLACED BY:			

PARTS LIST:
MODEL : PAM1400/1000
DATE: 081193

SOFT START AND POWER CIRCUIT
DRW. No 33.0006PL
SHEET 1 OF 1 REPLACES:

REV:
REPLACED BY:

REFERENCE	VALUE
C801	2 μ 2/63
C802	2 μ 2/63
C803	47 μ /100
C804	47 μ /100
C805	10n/400
D801	1N4007
D802	1N4007
D803	1N4007
D804	1N4007
F801	TF117°C
J801	FASTON 6.3
J802	FASTON 6.3
J803	TP+MJ
J804	FASTON 6.3
J805	FASTON 6.3
J806	FASTON 6.3
J807	FASTON 6.3
J808	FASTON 6.3
J809	FASTON 6.3
J810	FASTON 6.3
J811	FASTON 6.3
K801	E3209 6000 \dot{U}
K802	E3209 6000 \dot{U}
R801	W4k7/5
R802	6k8/2
R803	6k8/2
R804	2,2/1
R805	W39/8
R806	W39/8
R807	W39/8
WIRE 26	WIRE 26
WIRE 5	WIRE 5
WIRE 6	WIRE 6
WIRE 7	WIRE 7
CTO 11.0499	CTO.FRA.CU.

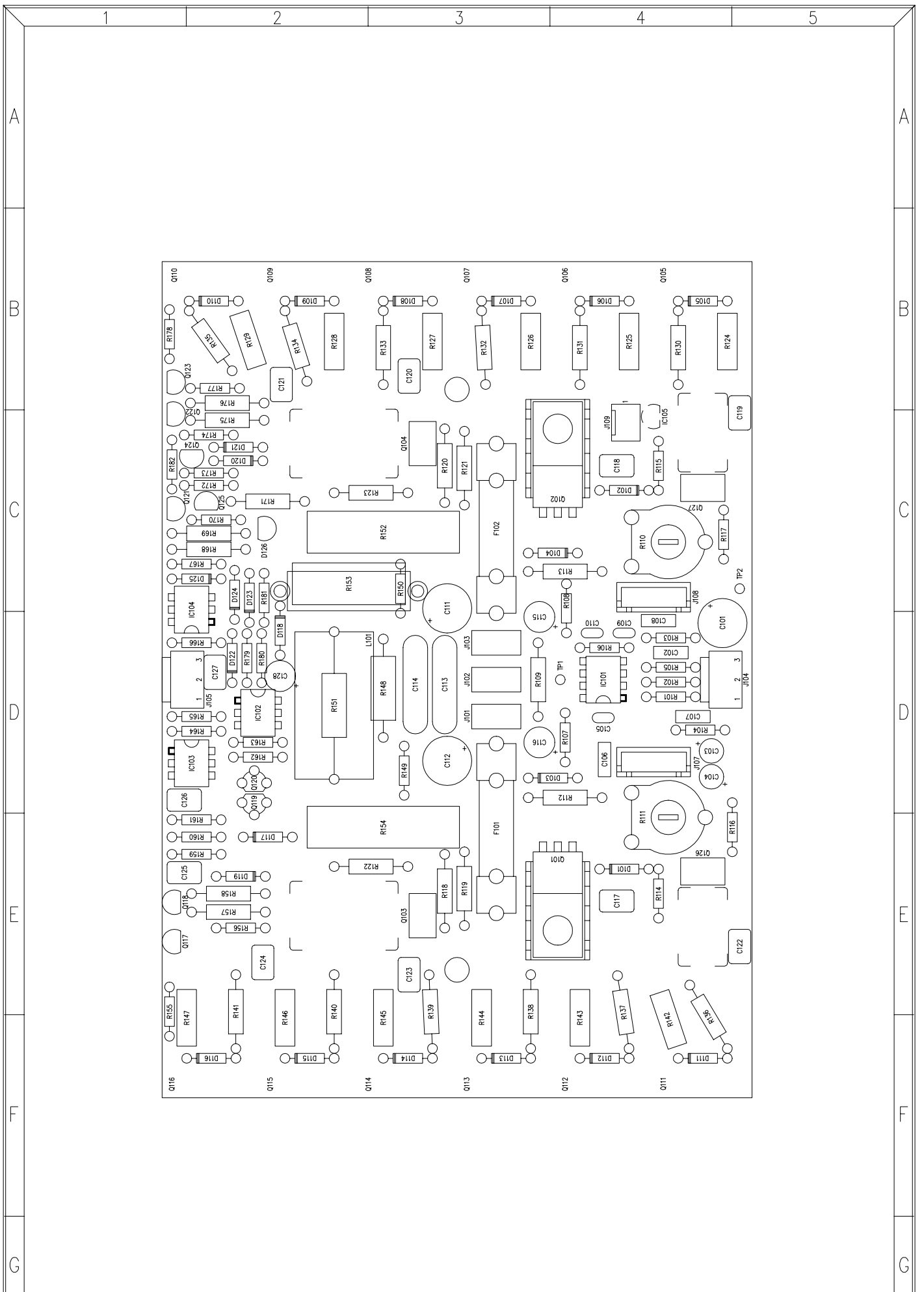

TITLE: POWER CIRCUIT AND SHORT CIRCUIT PROTECTION		MODEL: PAM1400		 LABORATORIO DE ELECTRO-ACUSTICA BARCELONA ESPAÑA	
DRAWN: J.QUERALT		SHEET 1 OF 7			
DATE: 081193		REPLACES:		DRW. NO. 33.0001R/	
CHECKED:		REPLACED BY:		REV. C	

PARTS LIST:
MODEL:PAM1400
DATE: 000621

POWER CIRCUIT AND AND SHORT CIRCUIT PROTECTION
DRW.N° 33.0001PL REV: A
SHEET 1 OF 4 REPLACED BY:

REFERENCE	VALUE
C101	47μ/100
C102	C100n
C103	10μ/50
C104	10μ/50
C105	C15p
C106	C100n
C107	C100n
C108	C100n
C109	C39p
C110	C39p
C111	47μ/100
C112	47μ/100
C113	100n/400
C114	47n/400
C115	47μ/50
C116	47μ/50
C117	680n
C118	680n
C119	220n/100
C120	220n/100
C121	220n/100
C122	220n/100
C123	220n/100
C124	220n/100
C125	680n
C126	680n
C127	1μ/63
C128	100μ/25
D101	Z3.6/1
D102	Z3.6/1
D103	Z11/1
D104	Z11/1
D105	Z12
D106	Z12
D107	Z12
D108	Z12
D109	Z12
D110	Z12
D111	Z12
D112	Z12
D113	Z12
D114	Z12
D115	Z12
D116	Z12
D117	Z30/1
D118	Z30/1
D119	Z30/1
D120	Z30/1
D121	Z30/1
D122	1N4148
D123	1N4148
D124	Z27/1
D125	Z10
D126	TL431
F101	TI-16A
F102	TI-16A
IC101	5534N
IC102	4N35

PARTS LIST:
MODEL:PAM1400
DATE: 000621

POWER CIRCUIT AND AND SHORT CIRCUIT PROTECTION
DRW.N° 33.0001PL REV: A
SHEET 2 OF 4 REPLACED BY:

REFERENCE VALUE

IC103	4N35
IC104	4N32
IC105	LM35D
J101	FASTON 6.3mm
J102	FASTON 6.3mm
J103	FASTON 6.3mm
J104	INPUT
J105	PROTEC
J107	B5B-XH
J108	B5B-XH
J109	2600-3TS
Q101	BF871
Q102	BF872
Q103	MJE15031
Q104	MJE15030
Q105	IRFP240
Q106	IRFP240
Q107	IRFP240
Q108	IRFP240
Q109	IRFP240
Q110	IRFP240
Q111	IRFP9240
Q112	IRFP9240
Q113	IRFP9240
Q114	IRFP9240
Q115	IRFP9240
Q116	IRFP9240
Q117	2N5401
Q118	2N5401
Q119	BC337
Q120	BC337
Q121	2N5551
Q122	2N5551
Q123	2N5551
Q124	BC547B
Q125	BC547B
Q126	BD437
Q127	BD437
R101	MF1k00
R102	MF47k5
R103	MF1k00
R104	680k
R105	680k
R106	MF51k1
R107	1k5
R108	1k5
R109	1k5/.5
R110	5k
R111	500O
R112	NF 390O/.5
R113	NF 680O/.5
R114	MF787O
R115	MF191O
R116	MF191O
R117	MF787O
R118	NF120O/1
R119	10O/.5
R120	NF120O/1

PARTS LIST:
MODEL:PAM1400
DATE: 000621

POWER CIRCUIT AND AND SHORT CIRCUIT PROTECTION
DRW.N° 33.0001PL REV: A
SHEET 3 OF 4 REPLACED BY:

REFERENCE	VALUE
R121	100/.5
R122	6.80/.5
R123	6.80/.5
R124	W.220/5
R125	W.220/5
R126	W.220/5
R127	W.220/5
R128	W.220/5
R129	W.220/5
R130	NF3300/.5
R131	NF3300/.5
R132	NF3300/.5
R133	NF3300/.5
R134	NF3300/.5
R135	NF3300/.5
R136	NF3300/.5
R137	NF3300/.5
R138	NF3300/.5
R139	NF3300/.5
R140	NF3300/.5
R141	NF3300/.5
R142	W.220/5
R143	W.220/5
R144	W.220/5
R145	W.220/5
R146	W.220/5
R147	W.220/5
R148	NF2.20/2
R149	6.80
R150	6.80
R151	100/2
R152	W1k8/7
R153	W6.80/5
R154	W1k8/7
R155	MF1k00
R156	MF487
R157	5k6/.5
R158	8k2/.5
R159	2k7
R160	22k
R161	330k
R162	10k
R163	1000
R164	3k3
R165	820
R166	330k
R167	10k
R168	10k/.5
R169	4k7/.5
R170	MF5k62
R171	27k/.5
R172	MF464
R173	MF1k00
R174	2k7
R175	8k2/.5
R176	5k6/.5
R177	MF487
R178	MF1k00

PARTS LIST:
MODEL:PAM1400
DATE: 000621

POWER CIRCUIT AND AND SHORT CIRCUIT PROTECTION
DRW.N° 33.0001PL REV: A
SHEET 4 OF 4 REPLACED BY:

REFERENCE

VALUE

R179

22k

R180

1k

R181

2k7

CTO 11.0504

CTO.FRA.CU

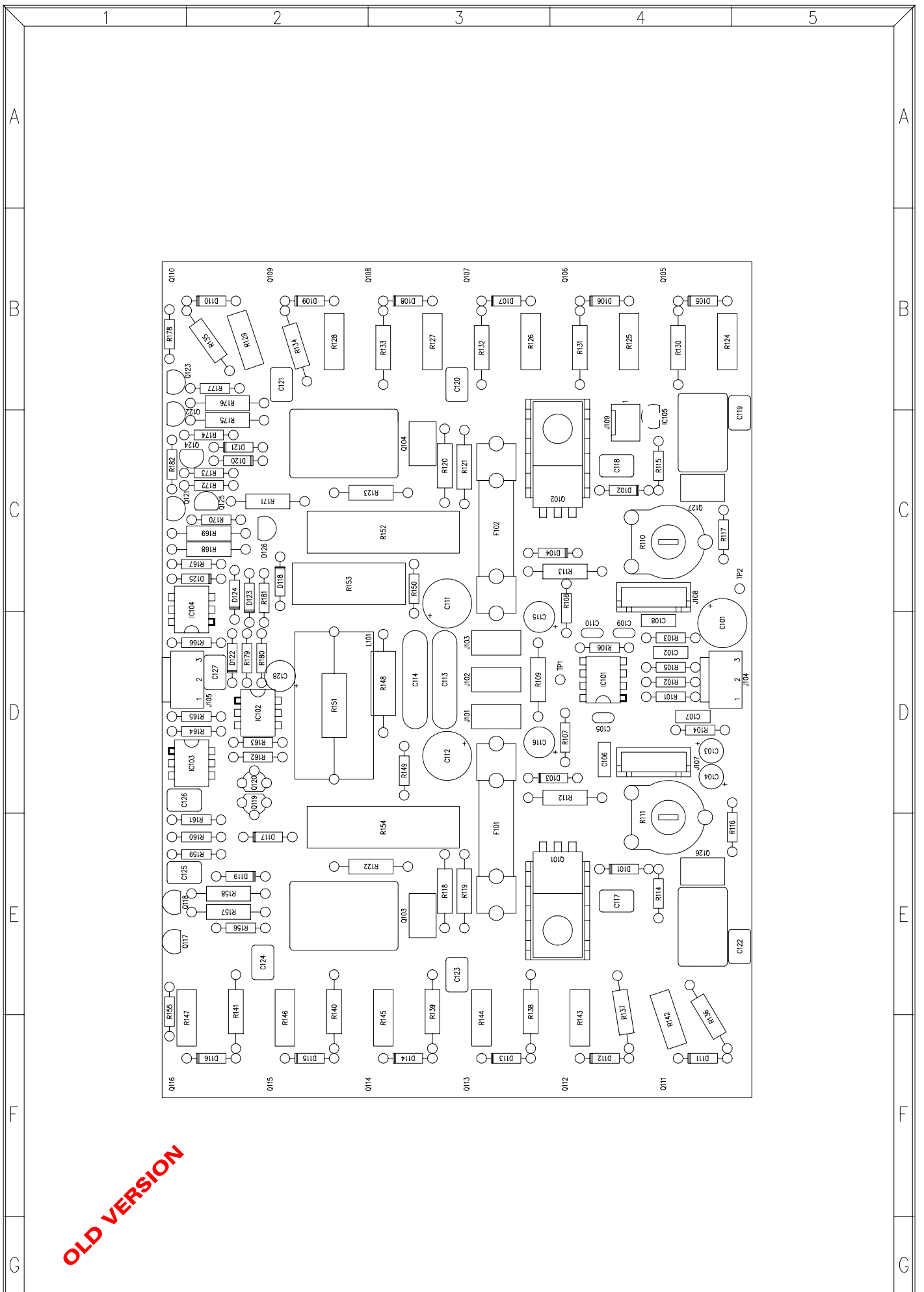

OLD VERSION

TITLE: POWER CIRCUIT AND SHORT CIRCUIT PROTECTION		MODEL: PAM1400		 LABORATORIO DE ELECTRO-ACUSTICA BARCELONA ESPAÑA	
DRAWN: J.QUERALT		SHEET 1 OF 7			
DATE: 081193		REPLACES:		DRW. NO.	REV.
CHECKED:		REPLACED BY:		33.0001R/	A

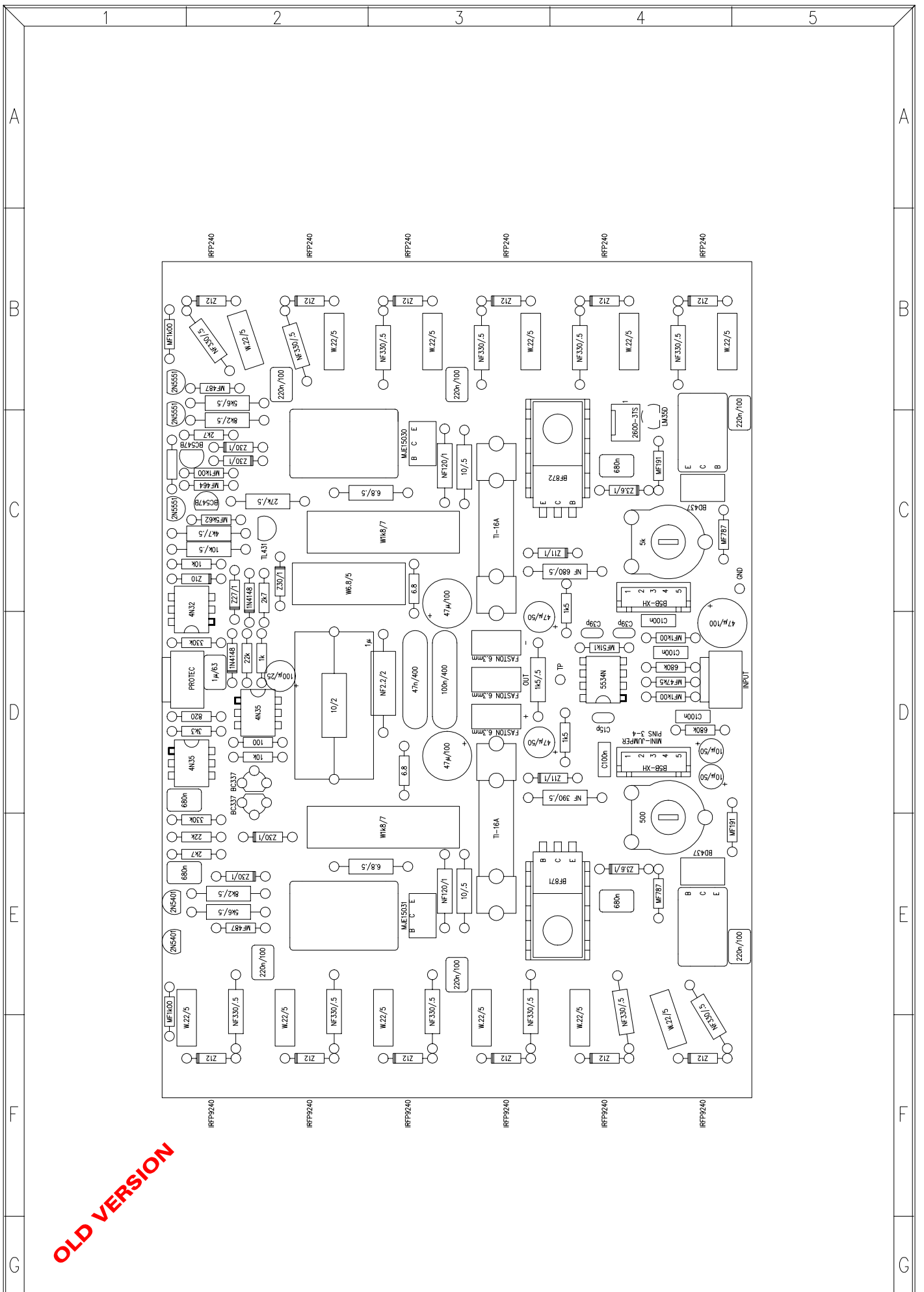

OLD VERSION

TITLE: POWER CIRCUIT AND SHORT CIRCUIT PROTECTION		MODEL: PAM1400		 LABORATORIO DE ELECTRO-ACUSTICA BARCELONA ESPAÑA	
DRAWN: J.QUERALT		SHEET 1 OF 7			
DATE: 081193		REPLACES:		DRW. NO. 33.0001 v/	
CHECKED:		REPLACED BY:		REV. A	

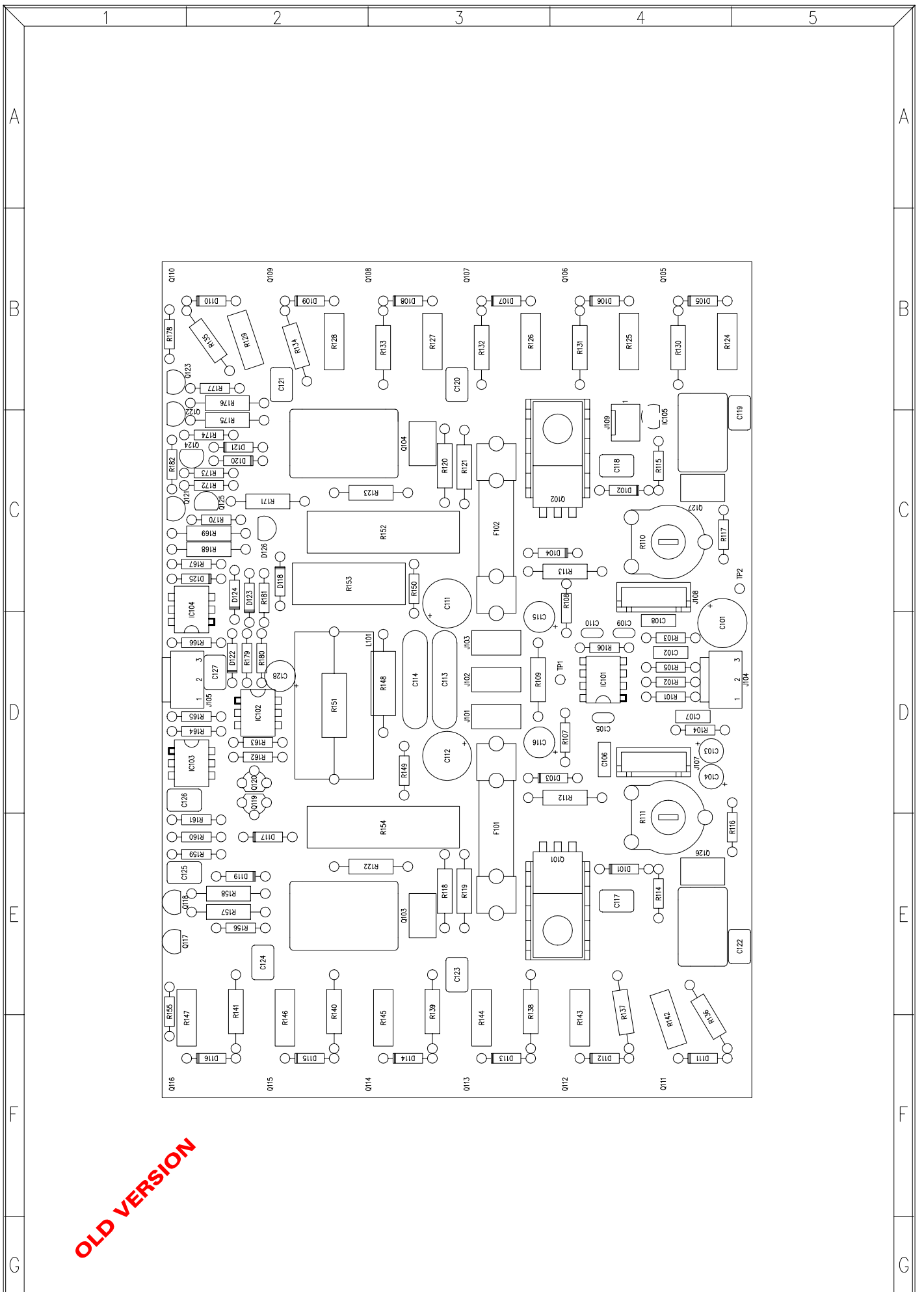

OLD VERSION

TITLE: POWER CIRCUIT AND SHORT CIRCUIT PROTECTION		MODEL: PAM1400		 LABORATORIO DE ELECTRO-ACUSTICA BARCELONA ESPAÑA	
DRAWN: J.QUERALT		DATE: 081193		SHEET 1 OF 7	
CHECKED:		DATE:		REPLACES:	
				REPLACED BY:	
				DRW. NO. 33.0001R/	
				REV.	

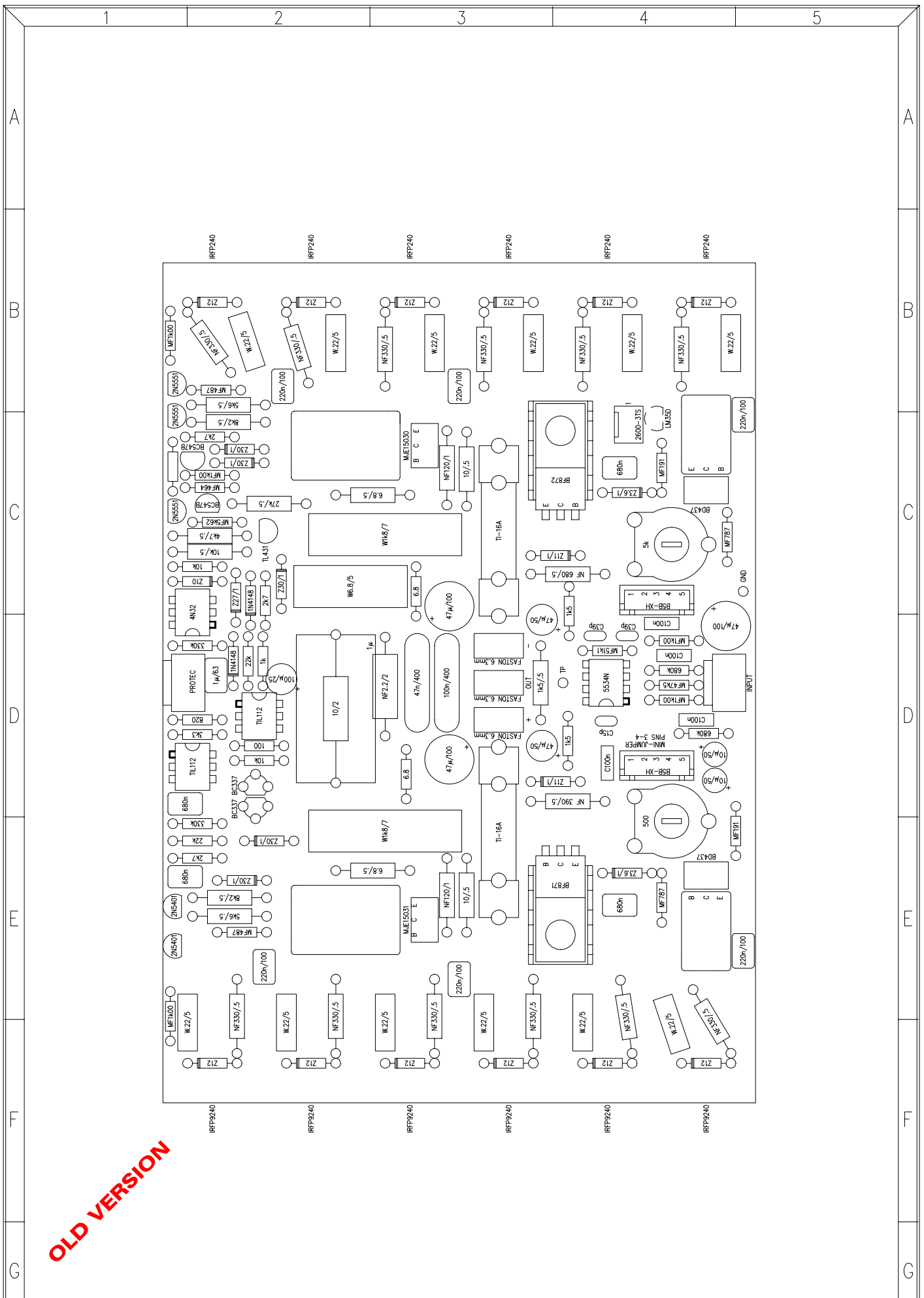

OLD VERSION

TITLE: POWER CIRCUIT AND SHORT CIRCUIT PROTECTION		MODEL: PAM1400		 LABORATORIO DE ELECTRO-ACUSTICA BARCELONA ESPAÑA	
DRAWN: J.QUERALT		SHEET 1 OF 7			
DATE: 081193		REPLACES:		DRW. NO.	
CHECKED:		REPLACED BY:		33.0001 v/	
DATE:				REV.	

PARTS LIST:
MODEL:PAM1400
DATE: 081193

POWER CIRCUIT AND AND SHORT CIRCUIT PROTECTION
DRW.N° 33.0001PL REV:
SHEET 1 OF 4 REPLACED BY:

REFERENCE	VALUE
C101	47μ/100
C102	C100n
C103	10μ/50
C104	10μ/50
C105	C15p
C106	C100n
C107	C100n
C108	C100n
C109	C39p
C110	C39p
C111	47μ/100
C112	47μ/100
C113	100n/400
C114	47n/400
C115	47μ/50
C116	47μ/50
C117	680n
C118	680n
C119	220n/100
C120	220n/100
C121	220n/100
C122	220n/100
C123	220n/100
C124	220n/100
C125	680n
C126	680n
C127	1μ/63
C128	100μ/25
D101	Z3.6/1
D102	Z3.6/1
D103	Z11/1
D104	Z11/1
D105	Z12
D106	Z12
D107	Z12
D108	Z12
D109	Z12
D110	Z12
D111	Z12
D112	Z12
D113	Z12
D114	Z12
D115	Z12
D116	Z12
D117	Z30/1
D118	Z30/1
D119	Z30/1
D120	Z30/1
D121	Z30/1
D122	1N4148
D123	1N4148
D124	Z27/1
D125	Z10
D126	TL431
F101	TI-16A
F102	TI-16A
IC101	5534N
IC102	TIL112

OLD VERSION

PARTS LIST:
MODEL:PAM1400
DATE: 081193

POWER CIRCUIT AND AND SHORT CIRCUIT PROTECTION
DRW.N° 33.0001PL REV:
SHEET 2 OF 4 REPLACED BY:

REFERENCE	VALUE
IC103	TIL112
IC104	4N32
IC105	LM35D
J101	FASTON 6.3mm
J102	FASTON 6.3mm
J103	FASTON 6.3mm
J104	INPUT
J105	PROTEC
J107	B5B-XH
J108	B5B-XH
J109	2600-3TS
Q101	BF871
Q102	BF872
Q103	MJE15031
Q104	MJE15030
Q105	IRFP240
Q106	IRFP240
Q107	IRFP240
Q108	IRFP240
Q109	IRFP240
Q110	IRFP240
Q111	IRFP9240
Q112	IRFP9240
Q113	IRFP9240
Q114	IRFP9240
Q115	IRFP9240
Q116	IRFP9240
Q117	2N5401
Q118	2N5401
Q119	BC337
Q120	BC337
Q121	2N5551
Q122	2N5551
Q123	2N5551
Q124	BC547B
Q125	BC547B
Q126	BD437
Q127	BD437
R101	MF1k00
R102	MF47k5
R103	MF1k00
R104	680k
R105	680k
R106	MF51k1
R107	1k5
R108	1k5
R109	1k5/.5
R110	5k
R111	500O
R112	NF 390O/.5
R113	NF 680O/.5
R114	MF787O
R115	MF191O
R116	MF191O
R117	MF787O
R118	NF120O/1
R119	10O/.5
R120	NF120O/1

OLD VERSION

PARTS LIST:
MODEL:PAM1400
DATE: 081193

POWER CIRCUIT AND AND SHORT CIRCUIT PROTECTION
DRW.N° 33.0001PL REV:
SHEET 3 OF 4 REPLACED BY:

REFERENCE	VALUE
R121	100/.5
R122	6.80/.5
R123	6.80/.5
R124	W.220/5
R125	W.220/5
R126	W.220/5
R127	W.220/5
R128	W.220/5
R129	W.220/5
R130	NF3300/.5
R131	NF3300/.5
R132	NF3300/.5
R133	NF3300/.5
R134	NF3300/.5
R135	NF3300/.5
R136	NF3300/.5
R137	NF3300/.5
R138	NF3300/.5
R139	NF3300/.5
R140	NF3300/.5
R141	NF3300/.5
R142	W.220/5
R143	W.220/5
R144	W.220/5
R145	W.220/5
R146	W.220/5
R147	W.220/5
R148	NF2.20/2
R149	6.80
R150	6.80
R151	100/2
R152	W1k8/7
R153	W6.80/5
R154	W1k8/7
R155	MF1k00
R156	MF487
R157	5k6/.5
R158	8k2/.5
R159	2k7
R160	22k
R161	330k
R162	10k
R163	1000
R164	3k3
R165	820
R166	330k
R167	10k
R168	10k/.5
R169	4k7/.5
R170	MF5k62
R171	27k/.5
R172	MF464
R173	MF1k00
R174	2k7
R175	8k2/.5
R176	5k6/.5
R177	MF487
R178	MF1k00

OLD VERSION

PARTS LIST:
MODEL:PAM1400
DATE: 081193

POWER CIRCUIT AND AND SHORT CIRCUIT PROTECTION
DRW.N° 33.0001PL REV:
SHEET 4 OF 4 REPLACED BY:

REFERENCE	VALUE
R179	22k
R180	1k
R181	2k7
CTO 11.0504	CTO.FRA.CU

OLD VERSION

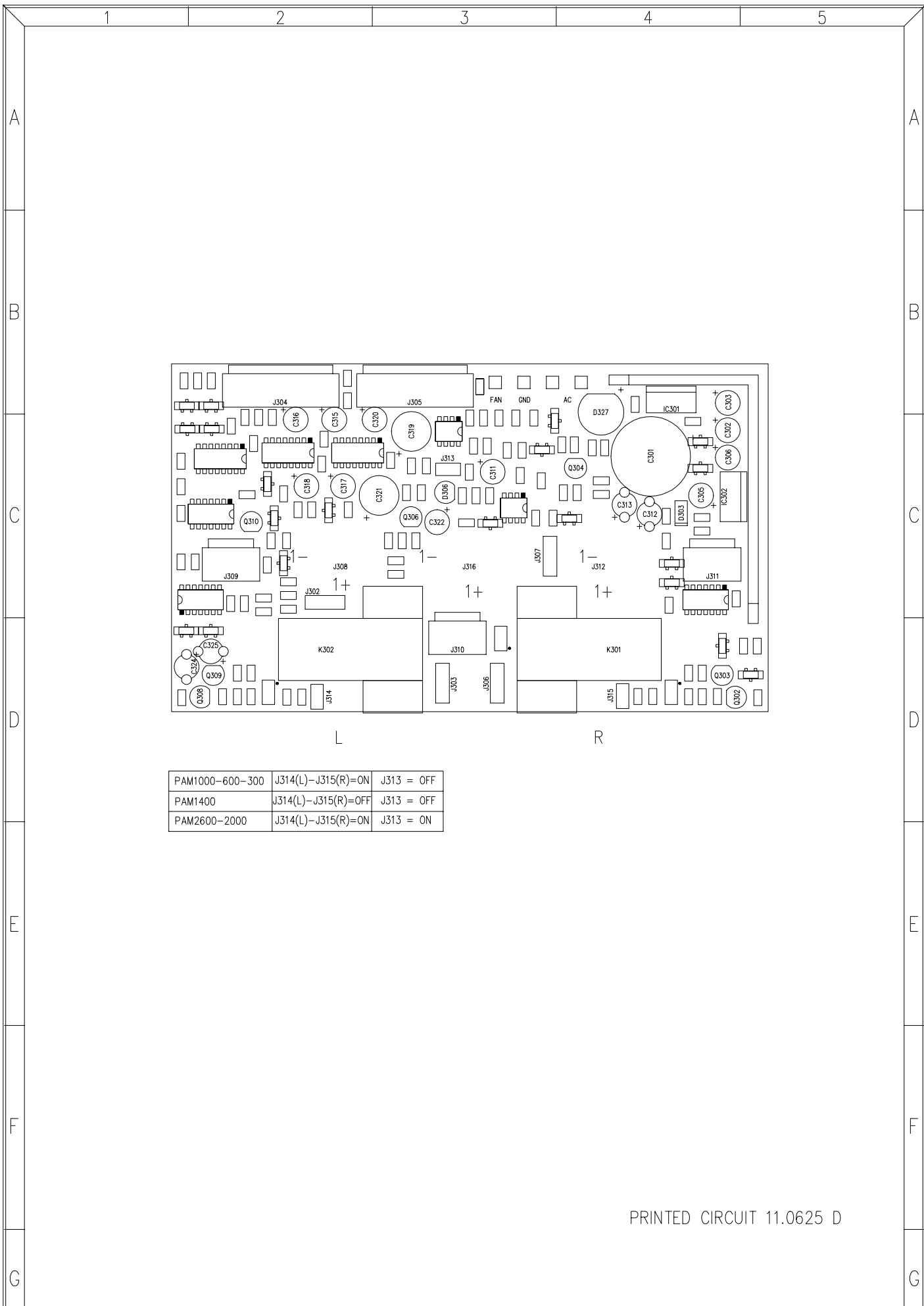

PAM1000-600-300	J314(L)-J315(R)=ON	J313 = OFF
PAM1400	J314(L)-J315(R)=OFF	J313 = OFF
PAM2600-2000	J314(L)-J315(R)=ON	J313 = ON

PRINTED CIRCUIT 11.0625 D

TITLE: PROTECTIONS CIRCUIT		MODEL: PAM2600-2000 1400-1000-600-300		 LABORATORIO DE ELECTRO-ACUSTICA BARCELONA ESPAÑA	
DRAWN: AMOROS/QUERALT		SHEET 1 OF 2			
DATE: 06.05.97		REPLACES:		DRW. NO. 33.0213 R	
CHECKED:		REPLACED BY:		REV. C	

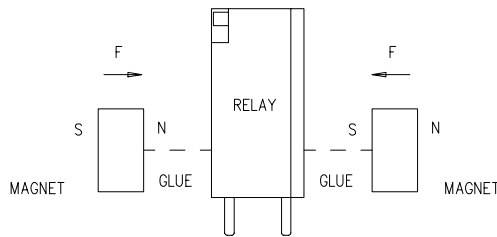

MAGNET ASSEMBLY DETAIL

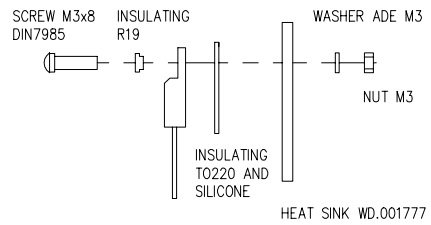

VOLTAGE REGULATOR ASSEMBLY DETAIL

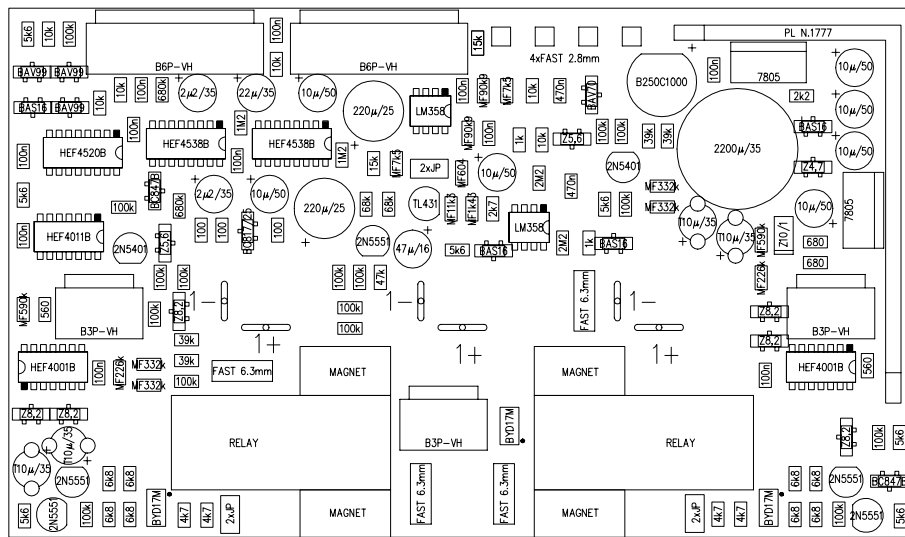

PAM1000-600-300	J314(L)-J315(R)=ON	J313 = OFF
PAM1400	J314(L)-J315(R)=OFF	J313 = OFF
PAM2600-2000	J314(L)-J315(R)=ON	J313 = ON

PAM600-300	RELAY = E 3209/4000 OHM
PAM1400-1000	RELAY = E 3209/6000 OHM
PAM2600-2000	RELAY = E 3209/4000 OHM

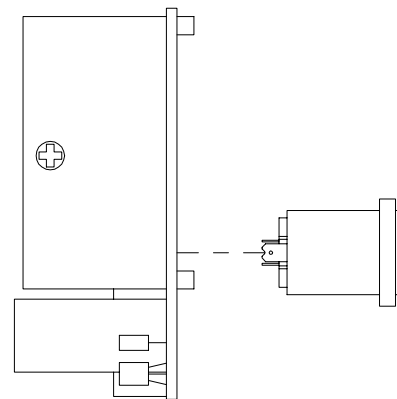

SPEAKER ASSEMBLY DETAIL

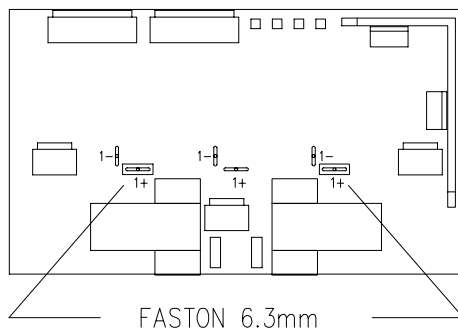

Nota: En el caso de las PAM2600-2000 las bases SPEAKON no van montadas y dos faston cambian de posición tal como muestra la figura.

PRINTED CIRCUIT 11.0625 D

TITLE: PROTECTIONS CIRCUIT		MODEL: PAM2600-2000 1400-1000-600-300	 LABORATORIO DE ELECTRO-ACUSTICA BARCELONA ESPAÑA		
DRAWN: AMOROS/QUERALT		SHEET 2 OF 2			REPLACES:
CHECKED:		DATE: 06.05.97	REPLACED BY:	DRW. NO. 33.0213 V	REV. C

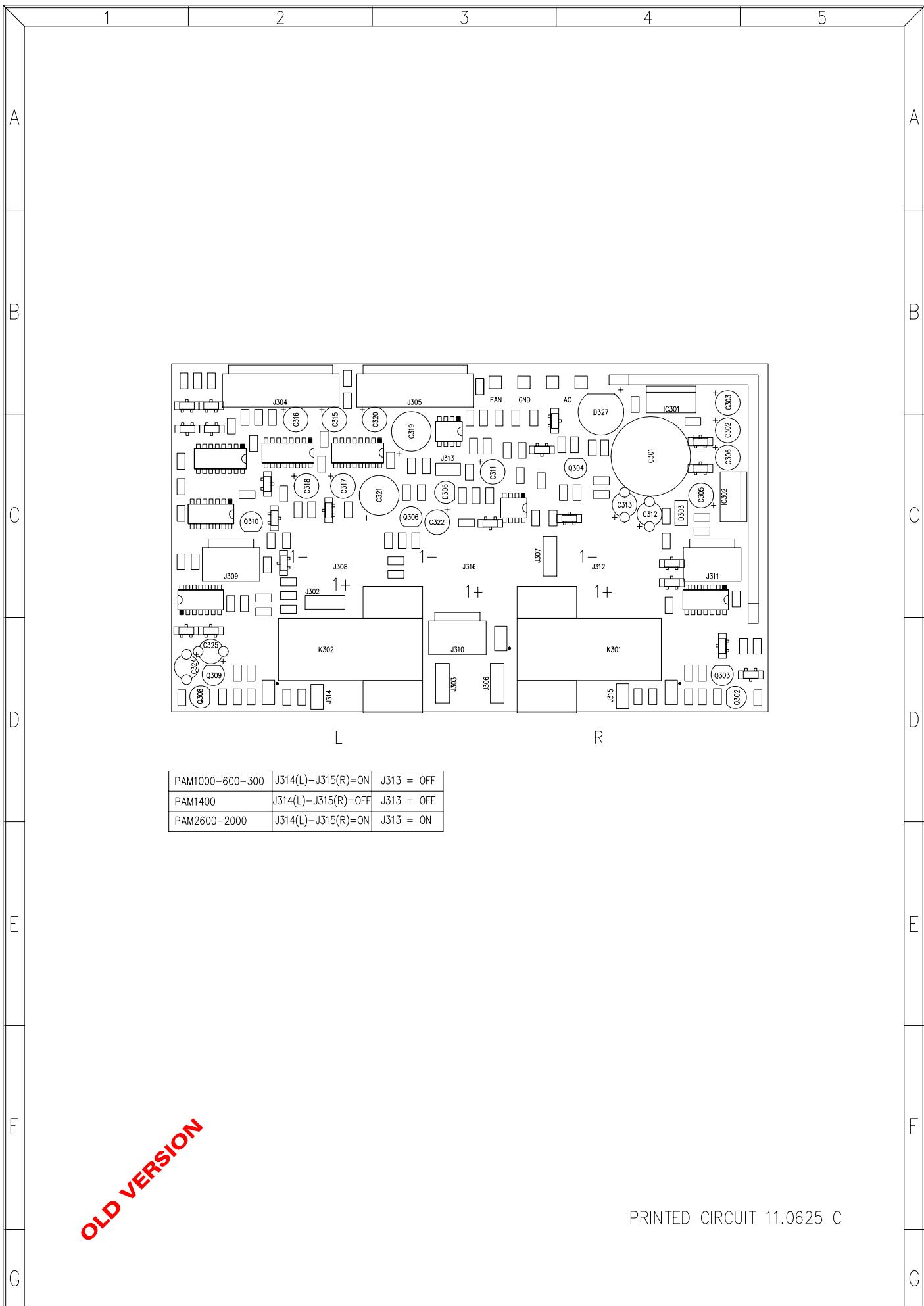

PAM1000-600-300	J314(L)-J315(R)=ON	J313 = OFF
PAM1400	J314(L)-J315(R)=OFF	J313 = OFF
PAM2600-2000	J314(L)-J315(R)=ON	J313 = ON

OLD VERSION

PRINTED CIRCUIT 11.0625 C

TITLE: PROTECTIONS CIRCUIT		MODEL: PAM2600-2000 1400-1000-600-300		 LABORATORIO DE ELECTRO-ACUSTICA BARCELONA ESPAÑA	
DRAWN: AMOROS/QUERALT		SHEET 1 OF 2			
DATE: 06.05.97		REPLACES:		DRW. NO. 33.0213 R	
CHECKED:		REPLACED BY:		REV. B	

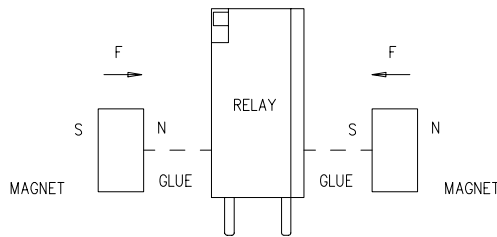

MAGNET ASSEMBLY DETAIL

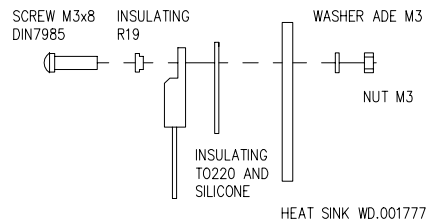

VOLTAGE REGULATOR ASSEMBLY DETAIL

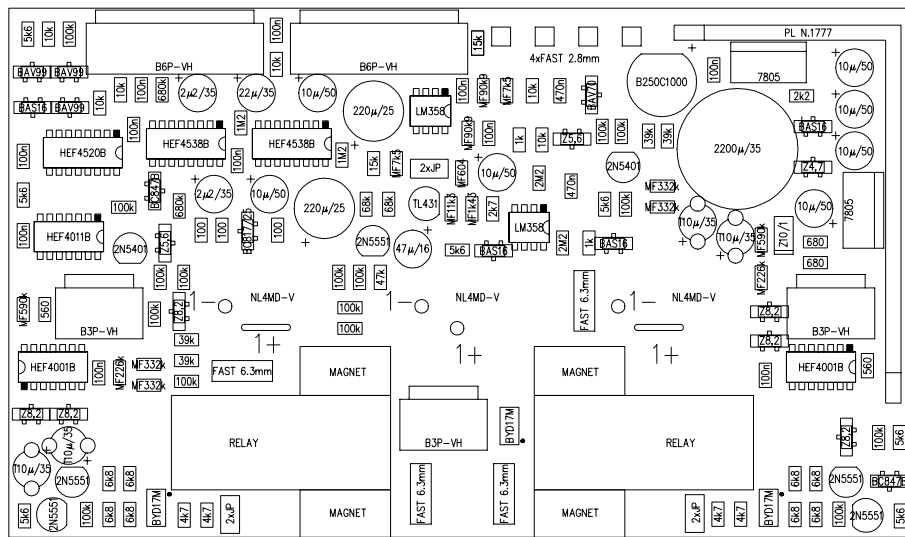

PAM1000-600-300	J314(L)-J315(R)=ON	J313 = OFF
PAM1400	J314(L)-J315(R)=OFF	J313 = OFF
PAM2600-2000	J314(L)-J315(R)=ON	J313 = ON

PAM600-300	RELAY = E 3209/4000 OHM
PAM1400-1000	RELAY = E 3209/6000 OHM
PAM2600-2000	RELAY = E 3209/4000 OHM

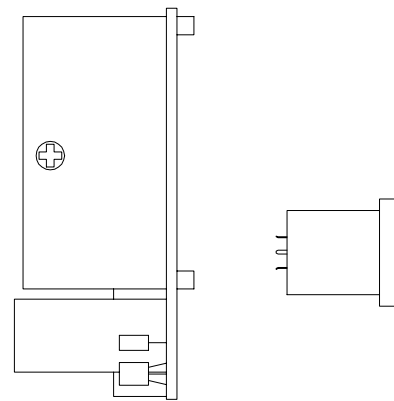

SPEAKER ASSEMBLY DETAIL

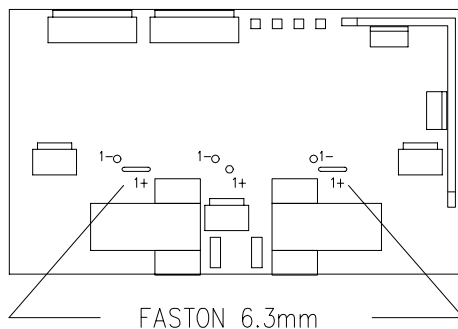

FASTON 6.3mm

Nota: En el caso de las PAM2600-2000 las bases SPEAKON no van montadas y dos faston cambian de posición tal como muestra la figura.

OLD VERSION

PRINTED CIRCUIT 11.0625 C

TITLE: PROTECTIONS CIRCUIT		MODEL: PAM2600-2000 1400-1000-600-300		 LABORATORIO DE ELECTRO-ACUSTICA BARCELONA ESPAÑA	
DRAWN: AMOROS/QUERALT		SHEET 2 OF 2			
CHECKED:		REPLACES:		DRW. NO. 33.0213 V	REV. B
DATE: 06.05.97		REPLACED BY:			

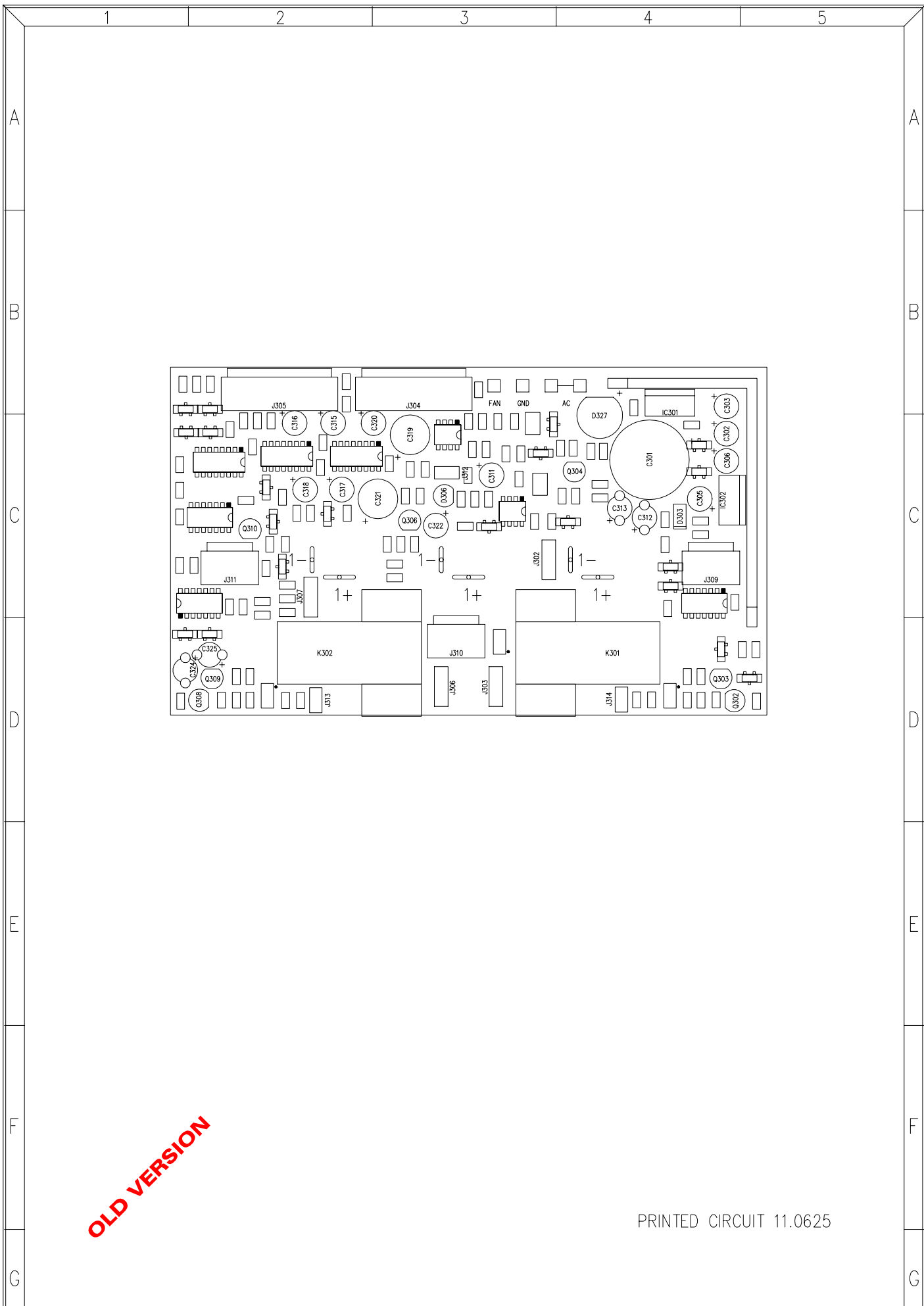

OLD VERSION

PRINTED CIRCUIT 11.0625

TITLE: PROTECTIONS CIRCUIT		MODEL: PAM2600-2000 1400-1000-600-300		 LABORATORIO DE ELECTRO-ACUSTICA BARCELONA ESPAÑA	
DRAWN: AMOROS/QUERALT		DATE: 06.05.97			
CHECKED:		DATE:		REPLACES:	
				REPLACED BY:	
				DRW. NO. 33.0213 R	
				REV.	

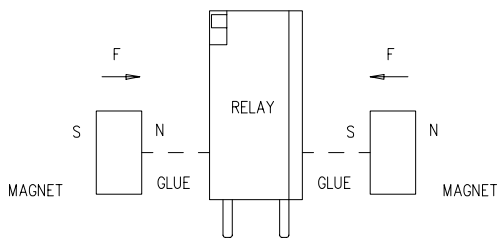
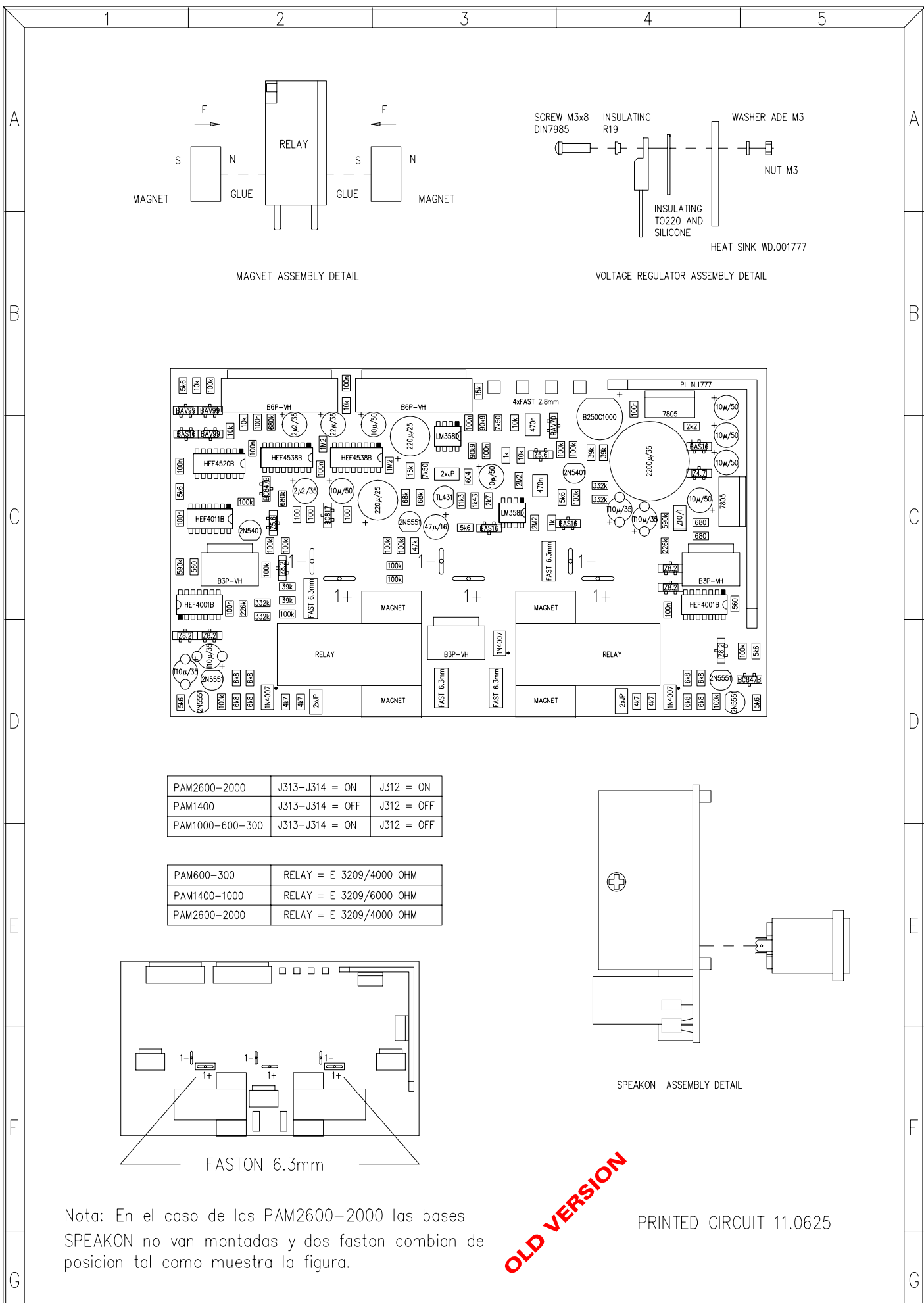

MAGNET ASSEMBLY DETAIL

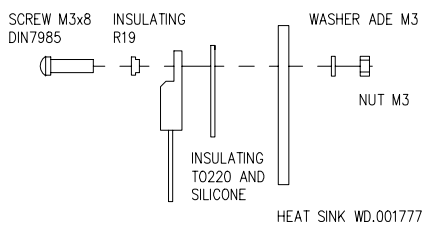

VOLTAGE REGULATOR ASSEMBLY DETAIL

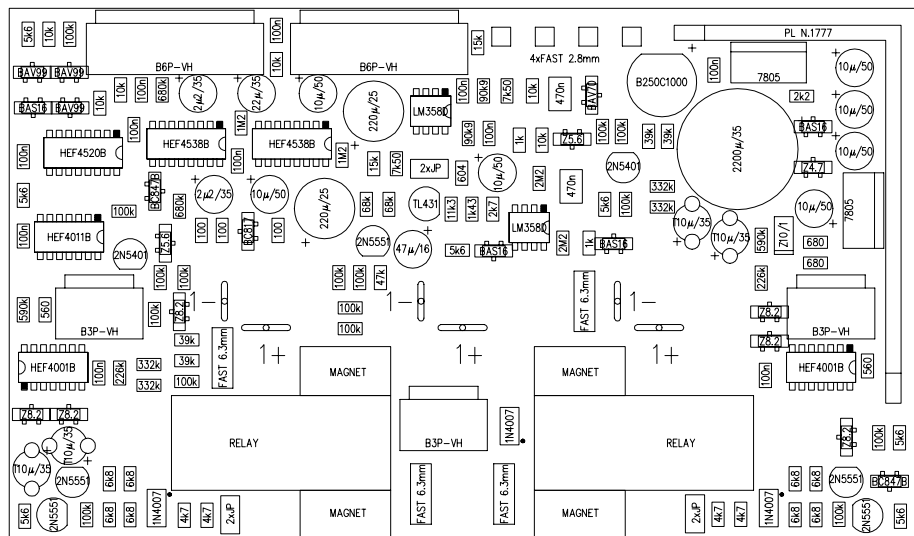

PAM2600-2000	J313-J314 = ON	J312 = ON
PAM1400	J313-J314 = OFF	J312 = OFF
PAM1000-600-300	J313-J314 = ON	J312 = OFF

PAM600-300	RELAY = E 3209/4000 OHM
PAM1400-1000	RELAY = E 3209/6000 OHM
PAM2600-2000	RELAY = E 3209/4000 OHM

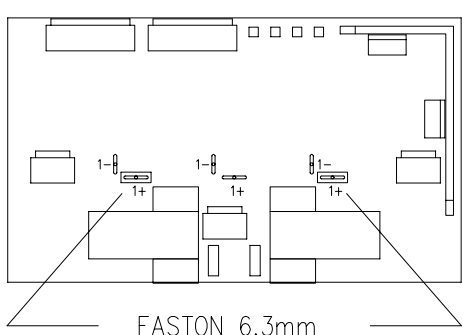

FASTON 6.3mm

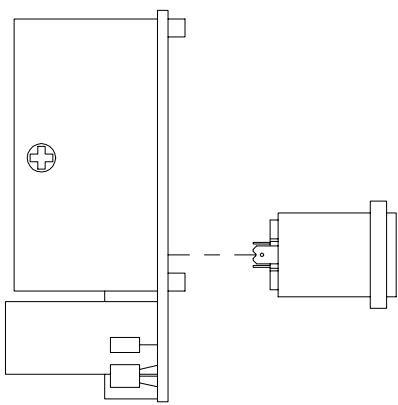

SPEAKON ASSEMBLY DETAIL

Nota: En el caso de las PAM2600-2000 las bases SPEAKON no van montadas y dos faston cambian de posicion tal como muestra la figura.

OLD VERSION

PRINTED CIRCUIT 11.0625

TITLE: PROTECTIONS CIRCUIT		MODEL: PAM2600-2000 1400-1000-600-300	 LABORATORIO DE ELECTRO-ACUSTICA BARCELONA ESPAÑA	
DRAWN: AMOROS/QUERALT		SHEET 2 OF 2		
DATE: 06.05.97	REPLACES:	REPLACED BY:	DRW. NO. 33.0213 V	REV.

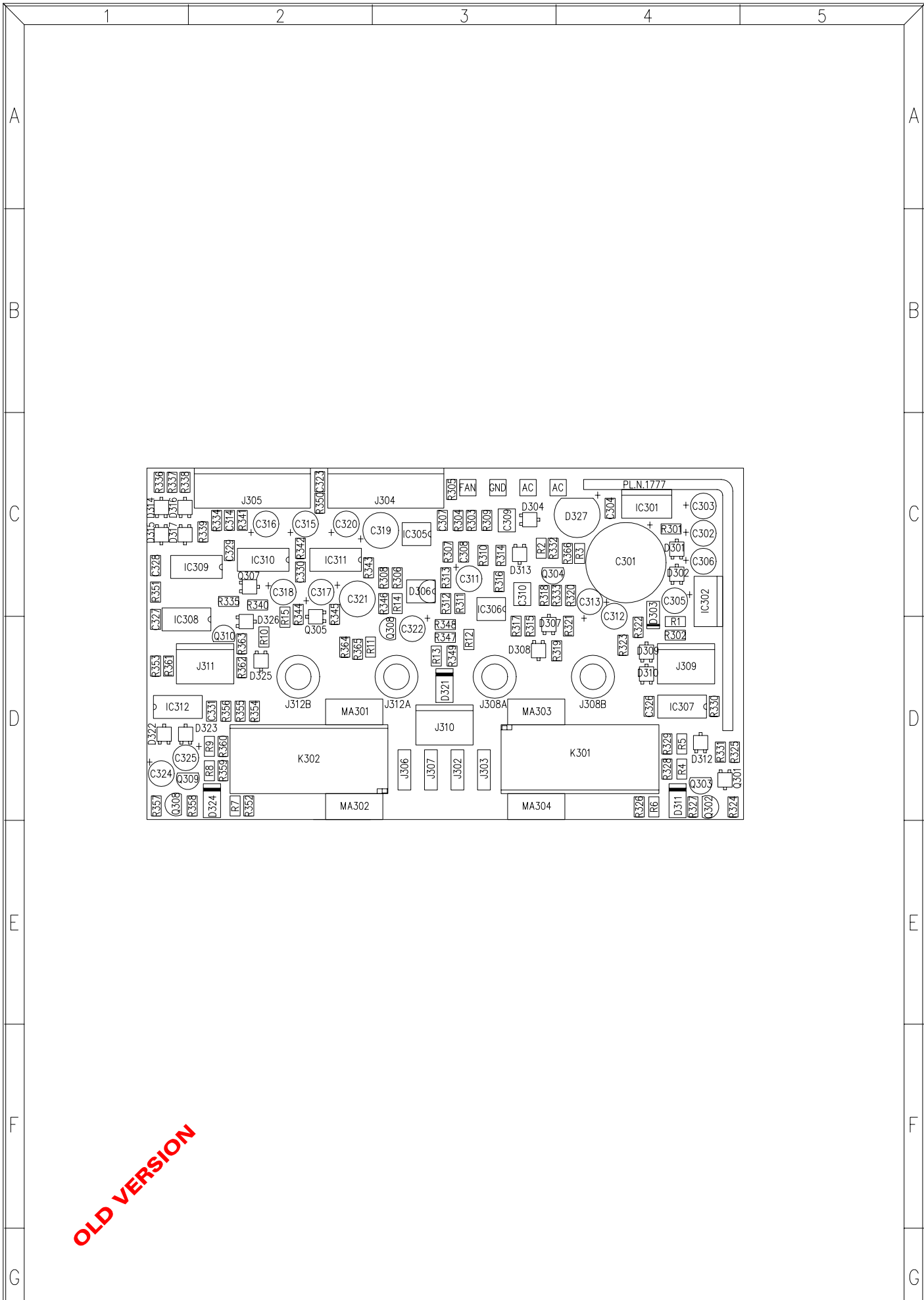

OLD VERSION

TITLE: PROTECTIONS CIRCUIT		MODEL: PAM1400		 LABORATORIO DE ELECTRO-ACUSTICA BARCELONA ESPAÑA	
		SHEET 7 OF 7			
DRAWN: J.QUERALT	DATE: 241293	REPLACES:		DRW. NO.	REV.
CHECKED:	DATE:	REPLACED BY:		33.0007 R/	

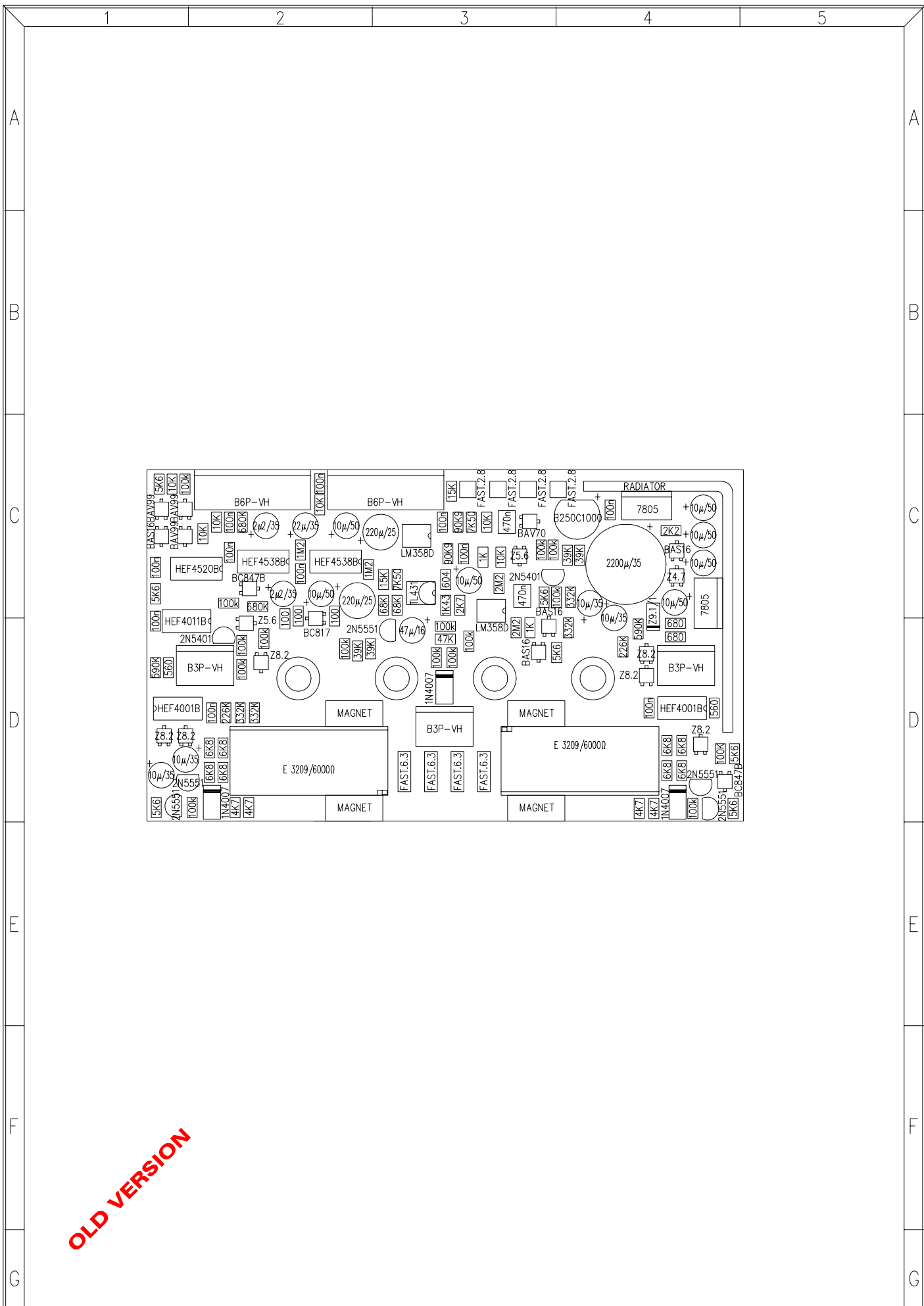

OLD VERSION

TITLE: PROTECTIONS CIRCUIT		MODEL: PAM1400		ECLERO	
		SHEET 7 OF 7		LABORATORIO DE ELECTRO-ACUSTICA BARCELONA ESPAÑA	
DRAWN: J.QUERALT	DATE: 241293	REPLACES:	DRW. NO. 33.0007	REV. V	
CHECKED:	DATE:	REPLACED BY:			

PARTS LIST:
MODEL : PAM1400
DATE: 241293

PROTECTIONS CIRCUIT
DRW. No 33.0007PL
SHEET 1 OF 4 REPLACES:

REV:
REPLACED BY:

REFERENCE	VALUE
AC	FAST.2.8
AC	FAST.2.8
C301	2200 μ /35
C302	10 μ /50
C303	10 μ /50
C304	100n
C305	10 μ /50
C306	10 μ /50
C307	100n
C308	100n
C309	470n
C310	470n
C311	10 μ /50
C312	10 μ /35
C313	10 μ /35
C314	100n
C315	22 μ /35
C316	2 μ 2/35
C317	10 μ /50
C318	2 μ 2/35
C319	220 μ /25
C320	10 μ /50
C321	220 μ /25
C322	47 μ /16
C323	100n
C324	10 μ /35
C325	10 μ /35
C326	100n
C327	100n
C328	100n
C329	100n
C330	100n
C331	100n
D301	BAS16
D302	Z4.7
D303	Z9.1/1
D304	BAV70
D306	TL431
D307	BAS16
D308	BAS16
D309	Z8.2
D310	Z8.2
D311	1N4007
D312	Z8.2
D313	Z5.6
D314	BAV99
D315	BAS16
D316	BAV99
D317	BAV99
D321	1N4007
D322	Z8.2
D323	Z8.2
D324	1N4007
D325	Z8.2
D326	Z5.6
D327	B250C1000

OLD VERSION

PARTS LIST:
MODEL : PAM1400
DATE: 241293

PROTECTIONS CIRCUIT
DRW. No 33.0007PL
SHEET 2 OF 4 REPLACES:

REV:
REPLACED BY:

REFERENCE	VALUE
FAN	FAST.2.8
GND	FAST.2.8
IC301	7805
IC302	7805
IC305	LM358D
IC306	LM358D
IC307	HEF4001B
IC308	HEF4011B
IC309	HEF4520B
IC310	HEF4538B
IC311	HEF4538B
IC312	HEF4001B
INSULANT WASHER	R19
INSULANT WASHER	R19
J302	FAST.6.3
J303	FAST.6.3
J304	B6P-VH
J305	B6P-VH
J306	FAST.6.3
J307	FAST.6.3
J309	B3P-VH
J310	B3P-VH
J311	B3P-VH
K301	E 3209/6000Ω
K302	E 3209/6000Ω
MA301	MAGNET
MA302	MAGNET
MA303	MAGNET
MA304	MAGNET
NUT	M3
NUT	M3
PL.N.1777	RADIATOR
Q301	BC847B
Q302	2N5551
Q303	2N5551
Q304	2N5401
Q305	BC817
Q307	BC847B
Q308	2N5551
Q308	2N5551
Q309	2N5551
Q310	2N5401
R1	680
R10	100k
R11	39K
R12	100k
R13	100k
R14	68K
R15	100
R2	100k
R3	39K
R301	2K2
R302	680
R303	7K50
R304	90K9
R305	15K

OLD VERSION

PARTS LIST:
MODEL : PAM1400
DATE: 241293

PROTECTIONS CIRCUIT
DRW. No 33.0007PL
SHEET 3 OF 4 REPLACES:

REV:
REPLACED BY:

REFERENCE	VALUE
R306	7K50
R307	90K9
R308	15K
R309	10K
R310	1K
R311	2K7
R312	1K43
R313	604
R314	10K
R315	1K
R316	2M2
R317	2M2
R318	5K6
R319	5K6
R320	332K
R321	332K
R322	590K
R323	226K
R324	5K6
R325	5K6
R326	4K7
R327	100k
R328	6K8
R329	6K8
R330	560
R331	100K
R332	100k
R333	100k
R334	10K
R335	100k
R336	5K6
R337	10K
R338	100k
R339	10K
R340	680K
R341	680K
R342	1M2
R343	1M2
R344	100
R345	100
R346	68K
R347	47K
R348	100k
R349	100k
R350	10K
R351	5K6
R352	4K7
R353	590K
R354	332K
R355	332K
R356	226K
R357	5K6
R358	100k
R359	6K8
R360	6K8
R361	560

OLD VERSION

PARTS LIST:
MODEL : PAM1400
DATE: 241293

PROTECTIONS CIRCUIT
DRW. No 33.0007PL
SHEET 4 OF 4 REPLACES:

REV:
REPLACED BY:

REFERENCE	VALUE
R362	100k
R363	100k
R364	100k
R365	39K
R366	39K
R4	6K8
R5	6K8
R6	4K7
R7	4K7
R8	6K8
R9	6K8
SCREW	M3X8 DIN7985 NINE
SCREW	M3X8 DIN7985 NINE
WASHER	ADE M3
WASHER	ADE M3
PC 11.0411	PRINTED CIRCUIT

OLD VERSION

PROFESSIONAL PAM SERIES - TESTING RULES

PRELIMINARY

GROUND LINK Testing.

- Verify that when the switch is at the ON position there is continuity between the chassis ground and the speakers ground terminal and that the opposite happens at the OFF position. Leave it at ON.
- Put the power amplifier in stereo mode.
- We will need a 1800VA variac for our test purposes.
- Take off one of the fuses of the module in which the testing is being made and connect an ammeter (10A DC scale) in its place.
- Put the oscilloscope probe between TP-GND.

SET UP

- Unplug the fuses of the module that we are NOT setting up.
- Connect the power amplifier mains cable to the output of the variac. Set the variac output at 0V.
- Switch the power amplifier on with no load or signal. Turn the variac up progressively step by step until 220V. While mains voltage is growing up make sure the module's current does never exceed 0.8A. Once the circuit is stable make sure the current is 480mA/400mA/320mA/240mA respectively for PAM1400/ PAM1000/ PAM600/ PAM300 and the symmetry (measured up with the oscilloscope probe) is $\leq 50\text{mV}$. If your figures do not match these numbers adjust CURRENT (5K) and SYMMETRY (470Ω) until you get the above mentioned numbers.
- Test the operational amplifier power supply ($\pm 18\text{V}$) $\pm 1\text{V}$.
- Put the fuse back in its place into the module (with the power amplifier turned off) and repeat the same procedure for the other channel.

CROSS DISTORTION

By using a signal generator introduce a level of 100mV RMS at 1kHz and make sure there is no cross distortion at the output (attenuators at 0dB position).

MOSFETS CONDUCTION

By using a signal generator introduce a level of 0.5V at 1kHz and load the amplifier with 4Ω . Check that all MOSFETs are conducting approximately the same current level (measure this current with the oscilloscope probe by palcing it on the $0,22\Omega$ source resistances). The maximum conduction difference between MOSFETs should be 100mV. When making this test be sure the oscilloscope ground is not connected to any other place of the circuit when making the reading; just to the $0,22\Omega$ resistance. If you do not follow this rule you could produce a shortcircuit between two points of the circuit and therefore a very important damage.

POWER

- Verify the amplifier's power at 8 and 4Ω .
- Maintain the mains voltage at 220V by means of the variac.
- Check that your own figures match the following at close-to-clip point:

		PAM1400	PAM1000	PAM600	PAM300
$V_{in} \approx 1\text{VRMS}/V_o$	4Ω	$\geq 49.0\text{Vrms}$	45.1Vrms	34.5Vrms	26Vrms
$V_{in} \approx 1\text{VRMS}/V_o$	8Ω	$\geq 56.0\text{Vrms}$	49.7Vrms	39.7Vrms	30Vrms

FREQUENCY RESPONSE

0.5V input signal.

Verify frequency response at 20Hz/2kHz/20kHz. We must get the same signal output for the actual load at any of the frequencies. Set the frequency at 50kHz; the output level should not decrease more than 1 or 2 dB and there should not be any noticeable distortion.

CLIPPING AT 1kHz

Introduce such a signal that the amplifier is just about to clip. Measure the voltage up at the output (with the actual load) and check that when the voltage decreases between 0.5 and 1 dB the clipping LEDs light down. Check each LED corresponds to its fader.

DC OUT

For this test you must disconnect the load from the amplifier.

Introduce a 1V signal at ≤ 5 Hz with the generator. Turn the output of the generator up until the protection relays open and close.

MONO-STEREO

Make this test with a load of 8Ω connected between left and right channels' terminals.

Set the MONO-STEREO switch in MONO. Verify that the fader of channel 1 is operating while channel 2 is NOT operating. Verify that the MONO LED is lighten up. Check the signal cut over the load is clean. Set the amplifier back to STEREO mode.

PROTECTIONS

Disconnect the amplifier from the load and introduce with the signal generator a level of approximately 100mV RMS at 1KHz. Leave the attenuators at 0dB and shortcircuit the left channel output (just for a while) checking the PROTECT LED is lighting up and the relay opens the circuit (you can check this by placinf an oscilloscope probe at the amplifier's output and watching the signal disappear during the STAND BY time in which the protection circuit is working).Repeat the same process for the right channel.

Set the amplifier in MONO mode in the same way as previously. Shortcircuit both channel output terminals (L and R) (just for a while).Any of both channels must go into protect mode, lighting the corresponding LED and making the relay open the circuit.

PROFESSIONAL PAM SERIES - QUALITY CONTROL

We will use a mixer with balanced output -if possible- and a nominal output level of 1V as the signal source for test purposes.

Connect the mixer outputs to the power amplifier inputs. Plug the power amplifier to mains (make sure its specified voltage matches that of mains) and make sure that PROTECT, ON and SIGNAL PRESENT LEDs all light up when you turn on the amplifier by pushing the ON button. Turn up the mixer output level until the CLIP LEDs light up on the power amplifier. Turn down the mixer output and connect the loudspeakers.

Make an exhaustive test of:

- Sound quality (no distortions or noises)
- Faders action (fader travel, signal cut at their low end, no scratching or clicking noises and correct stereo channel for each one).
- Cooling fan operation.
- While the power amplifier is working shake it or throw it a table to make sure the output sound goes on playing correctly.
- Shortcircuit the power amplifier output and make sure the corresponding channel's PROTECT LED lights up, the relay opens and the output signal is cut for a short period of time (STAND BY) and returned back into normal operation. Repeat the same procedure four times more and then the STAND BY time should be about 5 minutes. Repeat the same steps for the other channel.

TECHNICAL CHARACTERISTICS	PAM300	PAM600	PAM1000	PAM1400
Frequency response at max. power output.		7Hz to 60kHz +0 -1dB		
Harmonic distortion+noise from 20Hz to 20kHz meas.band	0,02%	0,02%	0,02%	0,02%
Intermodulation distortion (SMPTE) using frequencies of 50Hz and 7kHz at 4:1 ratio, nominal power.	≤0,03%	≤0,03%	≤0,03%	≥0,03%
TIM 100	≤0,05%	≤0,05%	≤0,05%	≤0,03%
Signal noise ratio from 20Hz to 20kHz Ref. 1W/4Ω To 4Ω nominal power.	≥85dB ≥107dB	≥80dB ≥105dB	≥80dB ≥106dB	≥85dB ≥110dB
Damping factor at 1kHz 8Ω	≥350	≥310	≥400	≥420
Slewrate	±32V/μs	±75V/μs	±80V/μs	±85V/μs
Channel crosstalk at 1kHz at 20kHz	≥80dB ≥60dB	≥80dB ≥60dB	≥80dB ≥55dB	≥80dB ≥55dB
Inputs balanced and provided with XLR3. CLIP indicators at -0,3dB	Sensitivity/load	0dBV/1V/47kΩ		
Outputs	These are provided with 2 pairs of 4mm banana.			
Protections	<ul style="list-style-type: none"> -Delayed turn-on heavy duty relay with PROTECT indicator ON during standby. -DC:4Hz or DC at 2V,PROTECT INDICATOR. -Thermal:A sensor activates a high temperature detection circuit,channel shut down at 90°,THERMAL indicator. -Overload:Protection against output short circuit.PROTECT indicator. -Autoreset:Four automatic reset during five minutes in case of short circuit.After this period reset mustbe done manually. -Soft start system (PAM 1000/1400) -Varispeed Fan controled according to internal temperature. 			
Power requirements 110V,120V 220V,230V,240V AC 50/60Hz	530VA	965VA	1443VA	1800VA
Dimensions Front pannel Chassis	482,6x88x5mm 440x88x420mm		482,6x132,5x5mm 440x132,5x420mm	
Weight	14,35kg	15,90kg	21,85kg	24,35kg

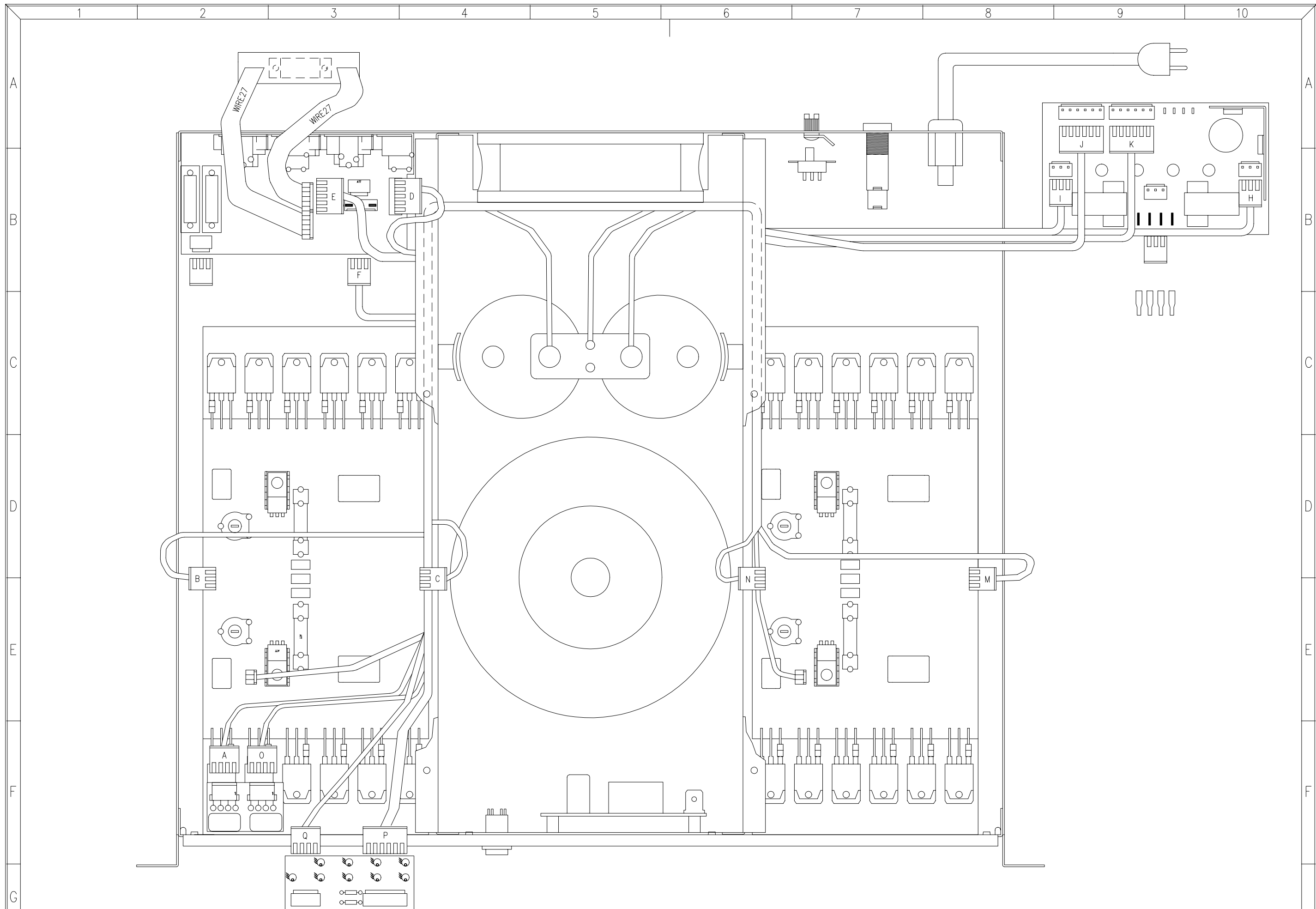

TITLE: WIRING DIAGRAM (SIGNAL)		MODEL: PAM1000N/1400N		 LABORATORIO DE ELECTRO-ACUSTICA BARCELONA ESPAÑA	
DRAWN: J.QUERALT		DATE: 061293			
CHECKED:		DATE:		REPLACES:	
				REPLACED BY:	
				DRW. NO. 31.0001	
				REV.	

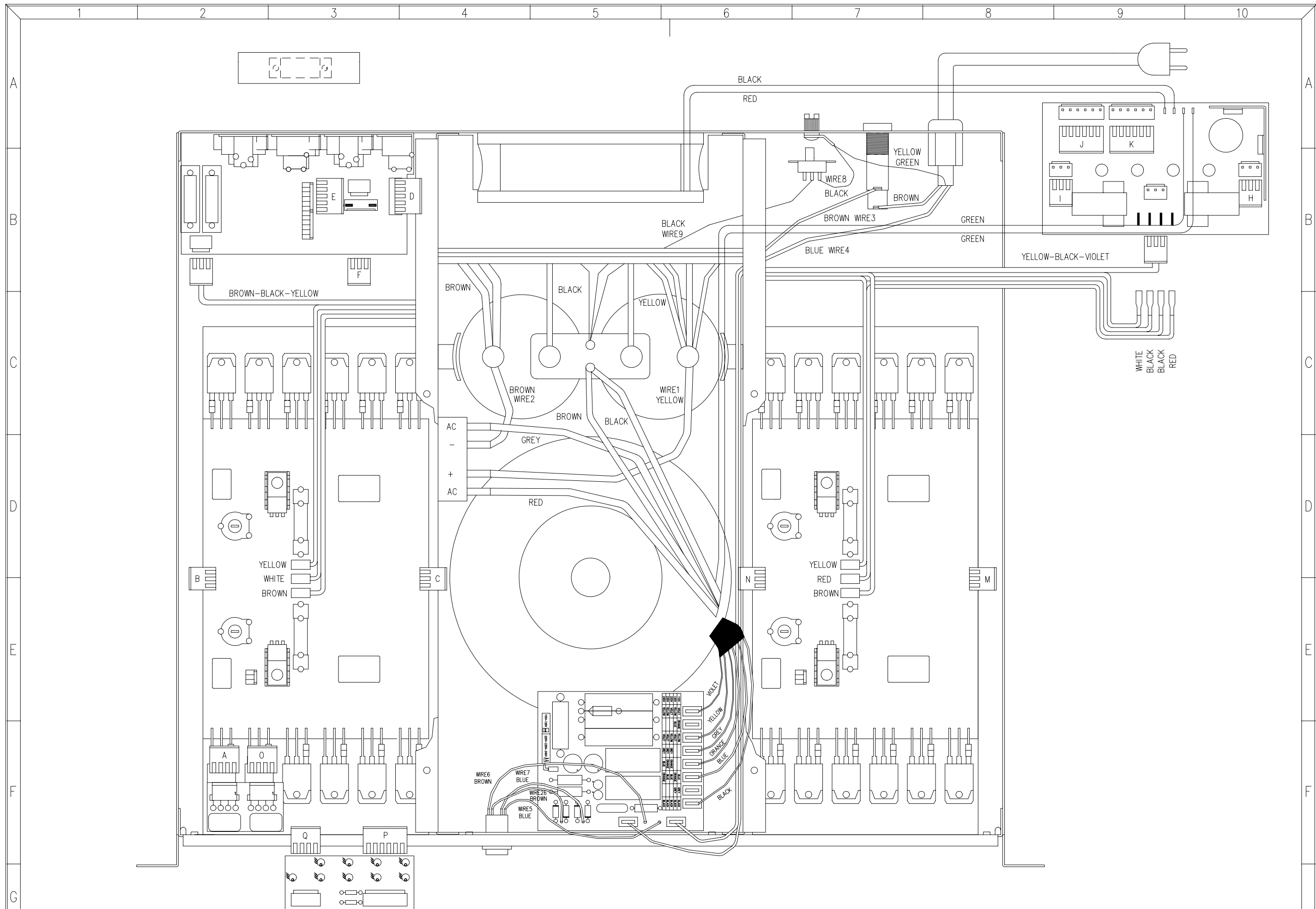

TITLE: WIRING DIAGRAM (POWER)		MODEL: PAM1000N/1400N		 LABORATORIO DE ELECTRO-ACUSTICA BARCELONA ESPAÑA	
DRAWN: J.QUERALT		DATE: 061293			
CHECKED:		DATE:		REPLACES:	
				REPLACED BY:	
				DRW. NO. 31.0002	
				REV.	

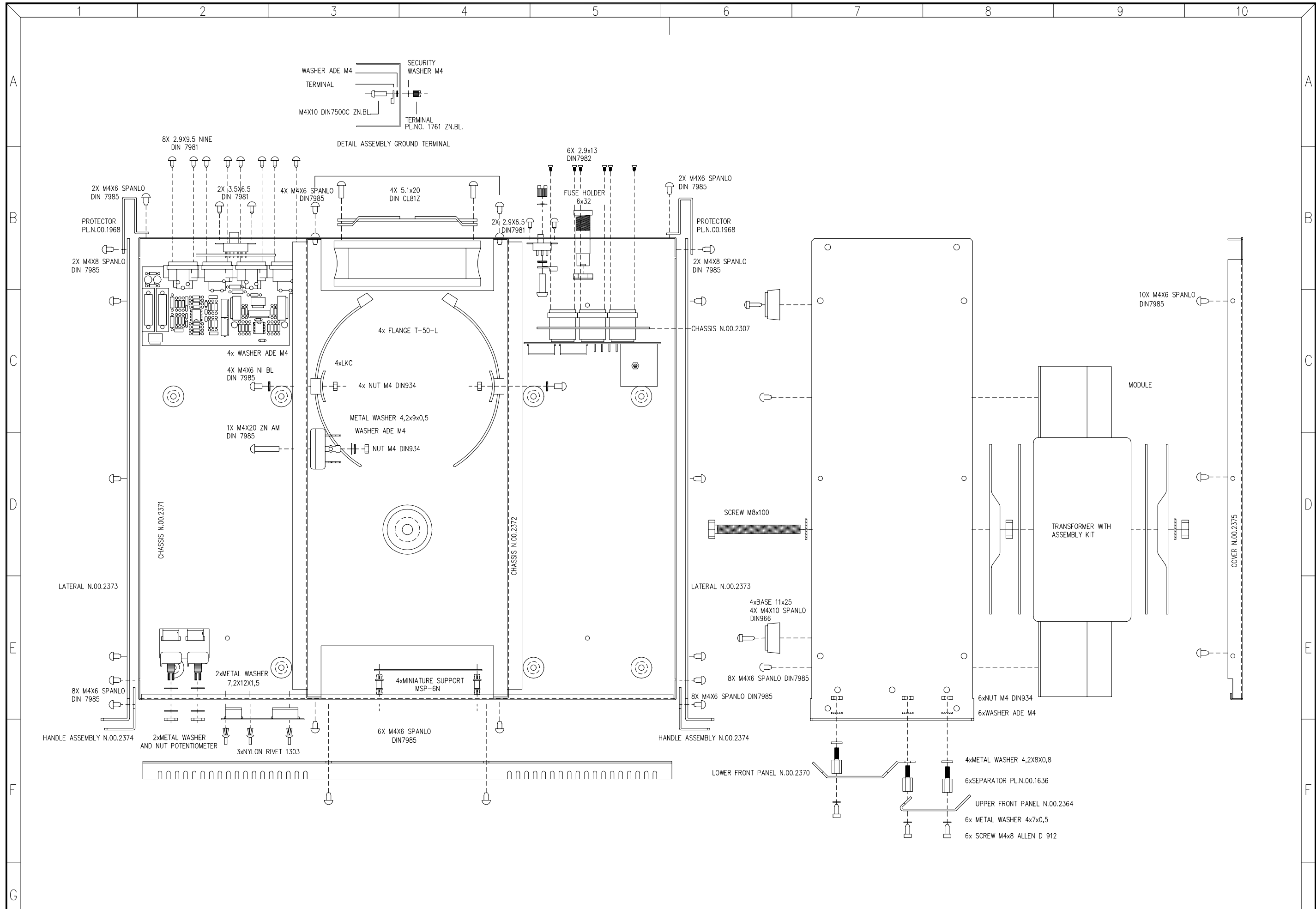

TITLE: MECHANICAL DIAGRAM		MODEL: PAM1400/1000		 LABORATORIO DE ELECTRO-ACUSTICA BARCELONA ESPAÑA
DRAWN: J.QUERALT		SHEET 1 OF 1		
DATE: 180297	REPLACES:	DRW. NO. 30.0001	REV. C	
CHECKED:	DATE:	REPLACED BY:		

PARTS LIST: MECHANICAL DIAGRAM
MODEL:PAM1400/1000 DRW.N° 300001PL
DATE: 180297 SHEET 1 OF 1

REV: C
REPLACES:
REPLACED BY:

QUANTITY DESCRIPT

10 SCREW 2,9x6,5 DIN7981
2 SCREW 3,5x6,5 DIN 7981
36 SCREW M4x6 SPANLO DIN7985
5 SCREW M4x12 DIN7985
1 SCREW M4x20 DIN7985
4 SCREW M4x10 SPANLO DIN966
6 SCREW M4x8 TX SPIRALFORM
4 SCREW M4x6 DIN7985
10 METAL WASHER ADE M4
1 METAL WASHER 4,2x9x0,5
6 METAL WASHER 4x7x0,5
4 METAL WASHER 4,2x9x1,5
9 NUT M4 DIN934
2 METAL WASHER AND NUT POTENTIOMETER
1 RIVET NUT M4-PSM
1 GROUND TERMINAL N°00.1761
1 SECURITY WASHER M4
3 NYLON RIVET 1303
4 MINIATURE SUPPORT MSP-6N
6 SEPARATOR N°00.1636
4 BASE 11x25
1 FUSE HOLDER 6x32
1 COMMUTATOR N°17.120
4 SUPPORT LKC
4 FLANGE T-50L
1 TRANSFORMER REF.21U212 (20Z194) WIT ASSEMBLY KIT
1 FAN REF.NMB4515 PL-04W B30
1 CHASSIS WD.00.2372
1 CHASSIS WD.002371
2 HANDLE ASSEMBLY WD.00.2374
1 COVER WD.00.2375
1 UPPER FRONT PANEL WD.00.2364
1 LOWER FRONT PANEL WD.00.2370
1 PROTECTOR FAN LZ-20
1 SCREW M4x10 DIN7500C ZNBL
1 CHASSIS WD.00.2307
6 SCREW 2.9x13 DIN7982

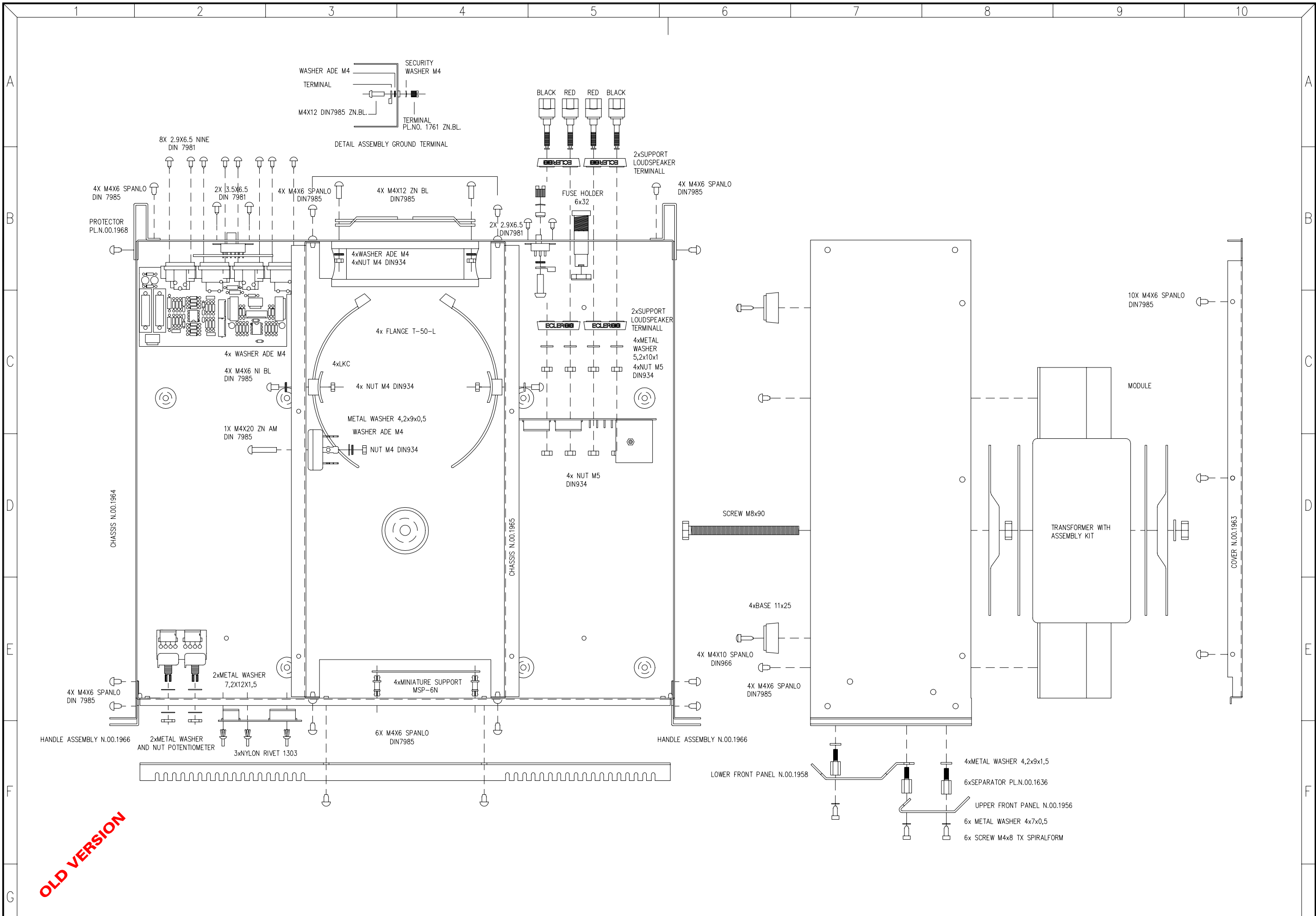

TITLE: MECHANICAL DIAGRAM		MODEL: PAM1400/1000		 LABORATORIO DE ELECTRO-ACUSTICA BARCELONA ESPAÑA	
DRAWN: J.QUERALT		DATE: 021293			
CHECKED:		DATE:		REPLACES:	
				REPLACED BY:	
				DRW. NO. 30.0001	
				REV.	

PARTS LIST: MECHANICAL DIAGRAM
MODEL : PAM1400/1000 DRW. No 30.0001PL
DATE: 021293 SHEET 1 OF 1

REV:
REPLACED BY:

QUANTITY VALUE

10 SCREW 2,9x6,5 DIN7981
2 SCREW 3,5x6,5 DIN 7981
36 SCREW M4x6 SPANLO DIN7985
5 SCREW M4x12 DIN7985
1 SCREW M4x20 DIN7985
4 SCREW M4x10 SPANLO DIN966
6 SCREW M4x8 TX SPIRALFORM
4 SCREW M4x6 DIN7985
10 METAL WASHER ADE M4
1 METAL WASHER 4,2x9x0,5
6 METAL WASHER 4x7x0,5
4 METAL WASHER 4,2x9x1,5
9 NUT M4 DIN934
8 NUT M5 DIN934
4 METAL WASHER 5,2x10x1
2 METAL WASHER AND NUT POTENTIOMETER
1 RIVET NUT M4-PSM
1 GROUND TERMINAL N°00.1761
1 SECURITY WASHER M4
3 NYLON RIVET 1303
4 MINIATURE SUPPORT MSP-6N
6 SEPARATOR N°00.1636
4 BASE 11x25
1 FUSE HOLDER 6x32
1 COMMUTATOR N°17.120
4 SUPPORT LKC
4 FLANGE T-50L
1 TRANSFORMER REF.21U212 (30Z194) WIT ASSEMBLY KIT
1 FAN REF.NMB4515 PL-04W B30
1 CHASSIS N°00.1965
1 CHASSIS N°00.1964
2 HANDLE ASSEMBLY N°00.1966
1 COVER N°00.1963
1 UPPER FRONT PANEL N°00.1956
1 LOWER FRONT PANEL N°00.1958
2 JOINED CONNECTOR LOUDSPEAKER
1 PROTECTOR FAN LZ-20

OLD VERSION

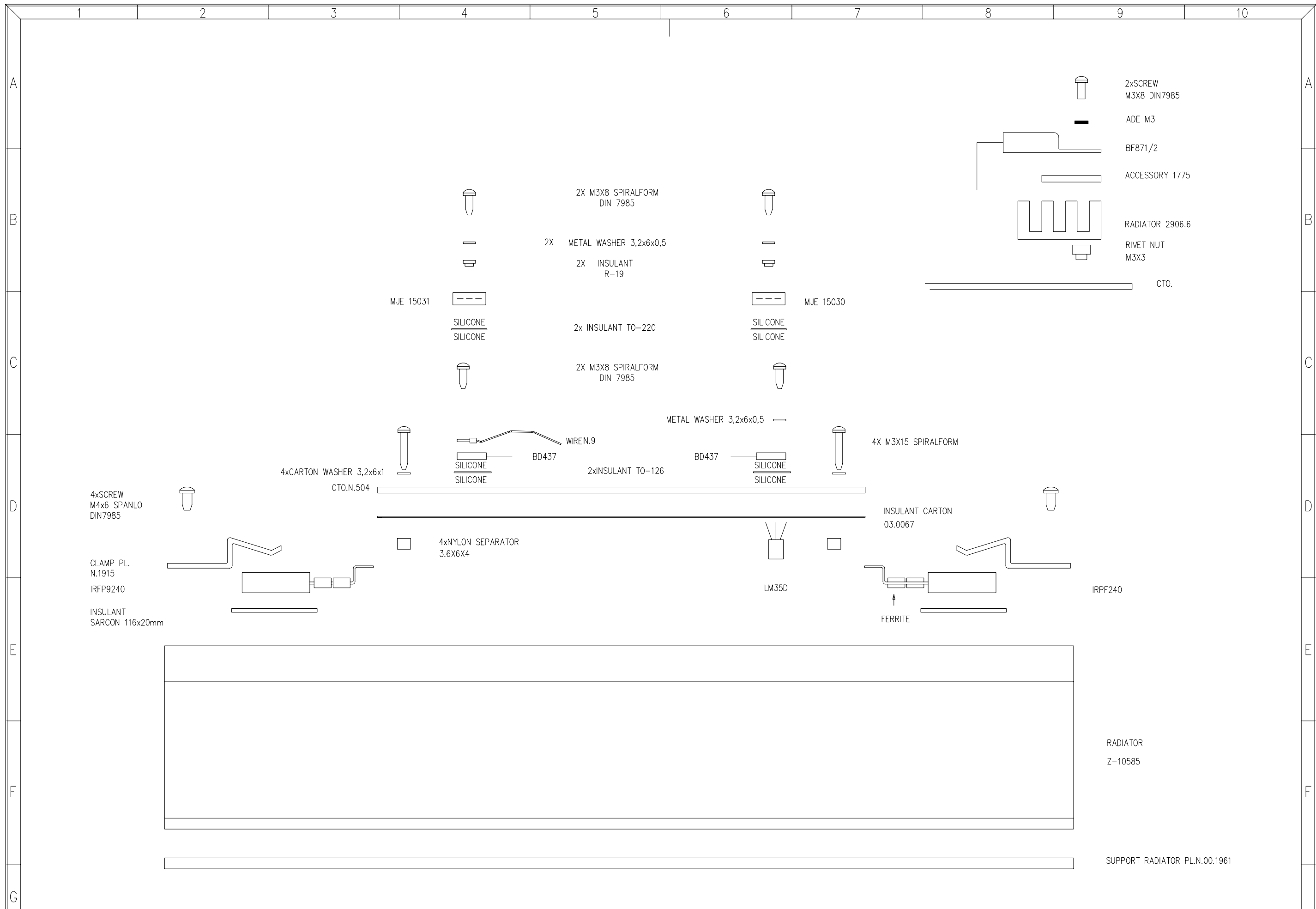

TITLE: ASSEMBLY MODULE		MODEL: PAM1400/1000		 LABORATORIO DE ELECTRO-ACUSTICA BARCELONA ESPAÑA	
DRAWN: J.QUERALT		DATE: 101293			
CHECKED:		DATE:		REPLACES:	
				DRW. NO. 30.0002	
				REV.	
				REPLACED BY:	

PARTS LIST: ASSEMBLY MODULE
MODEL : PAM1400/1000 DRW. No 30.0002PL
DATE: 101293 SHEET 1 OF 1 REPLACES:

REV:
REPLACED BY:

QUANTITY VALUE

3 METAL WASHER 3.2X6X0.5
2 INSULANT. WASHER R19
2 MICA TO-220
2 MICA TO-126
1 WIRE N°9
4 SCREW M3X8 SPIRALFORM DIN7985
4 SCREW M3X15 SPIRALFORM DIN 7985
4 NYLON SEPARATOR 3.6X6.4
4 SCREW M4X6 SPANLO DIN7985
2 RIVET NUT M3X3
2 ACCESSORY PL.N°1775
2 SCREW M3X8 DIN7985
2 WASHER ADE M3
2 ACCESSORY PL. N°1915
4 CARTON WASHER 3.2X6X1
1 INSULANT CARTON PL.N°03.0067
1 RADIATOR Z-10585
2 RADIATOR N°2906.6
2 INSULANT SARCON 116x20mm
1 SUPPORT RADIATOR N.00.1961

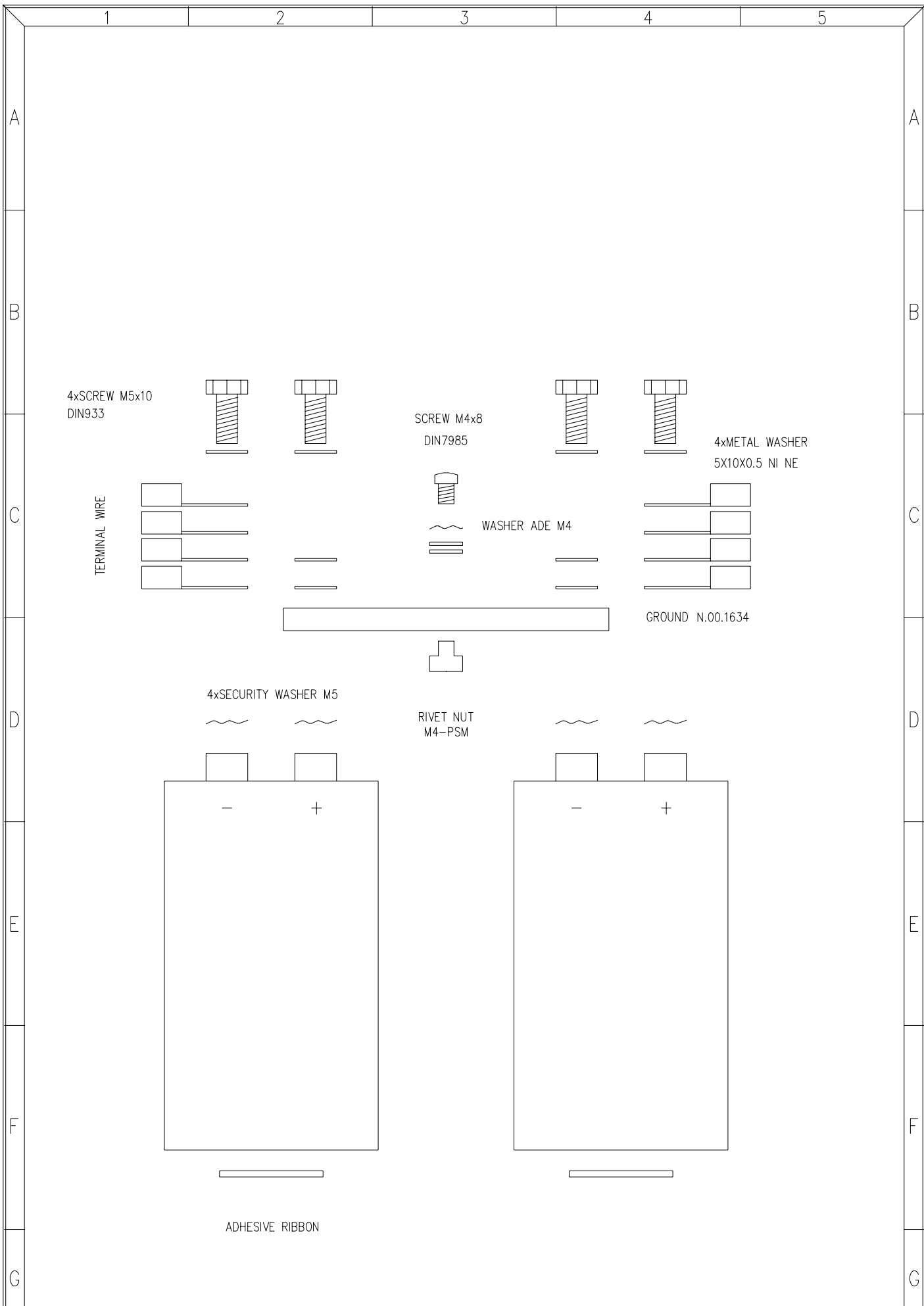

TITLE: ASSEMBLY FILTER CAPACITOR		MODEL: PAM1400/1000/600/300		 LABORATORIO DE ELECTRO-ACUSTICA BARCELONA ESPAÑA	
DRAWN: J.QUERALT		SHEET 1 OF 1			
DATE: 091293		REPLACES:		DRW. NO. 30.0003	
CHECKED:		REPLACED BY:		REV.	

PARTS LIST:
MODEL : PAM1400/1000/600/300
DATE: 091293

ASSEMBLY FILTER CAPACITOR
DRW. No 30.0003PL
SHEET 1 OF 1

REV:
REPLACED BY:

QUANTITY VALUE

4 SCREW M5x10 DIN933
1 SCREW M4x8 DIN7985
4 METAL WASHER 5x10x0,5
1 WASHER ADE M4
4 SECURITY WASHER M5
1 RIVET NUT M4-PSM
1 GROUND CHASSIS N°00.1634
2 ADHESIVE RIBBON 20mm

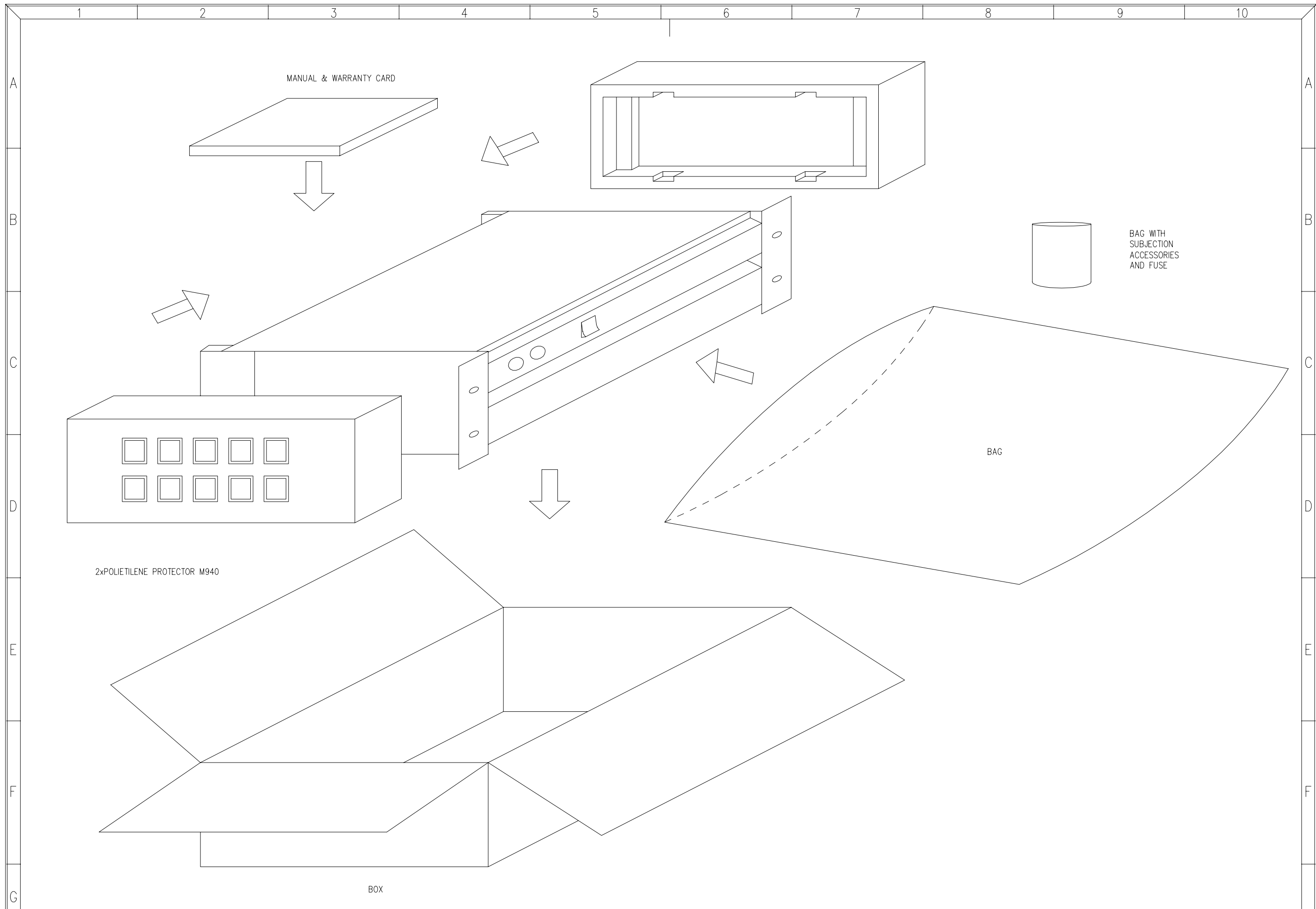

TITLE: PACKING DIAGRAM		MODEL: PAM1400/1000		 LABORATORIO DE ELECTRO-ACUSTICA BARCELONA ESPAÑA	
DRAWN: J.QUERALT		DATE: 091293			
CHECKED:		DATE:		REPLACED BY:	REV.

PARTS LIST: PACKING DIAGRAM
MODEL : PAM1400/1000 DRW. No 32.0001PL
DATE: 091293 SHEET 1 OF 1 REPLACES:

REV:
REPLACED BY:

QUANTITY VALUE

4 METAL WASHER 5x11,5x0,8
4 WASHER AT 5x11,5x3,5 ABS BLACK
1 FUSE 16A 6x32TI PO90610
1 BOX PAM1400
2 POLIETILENE PROTECTOR M940
1 CASE MANUAL 21,5x32,5
1 PLASTIC BAG 75x65
1 BAG 60x80
1 MANUAL PAM1400
1 WARRANTY CARD

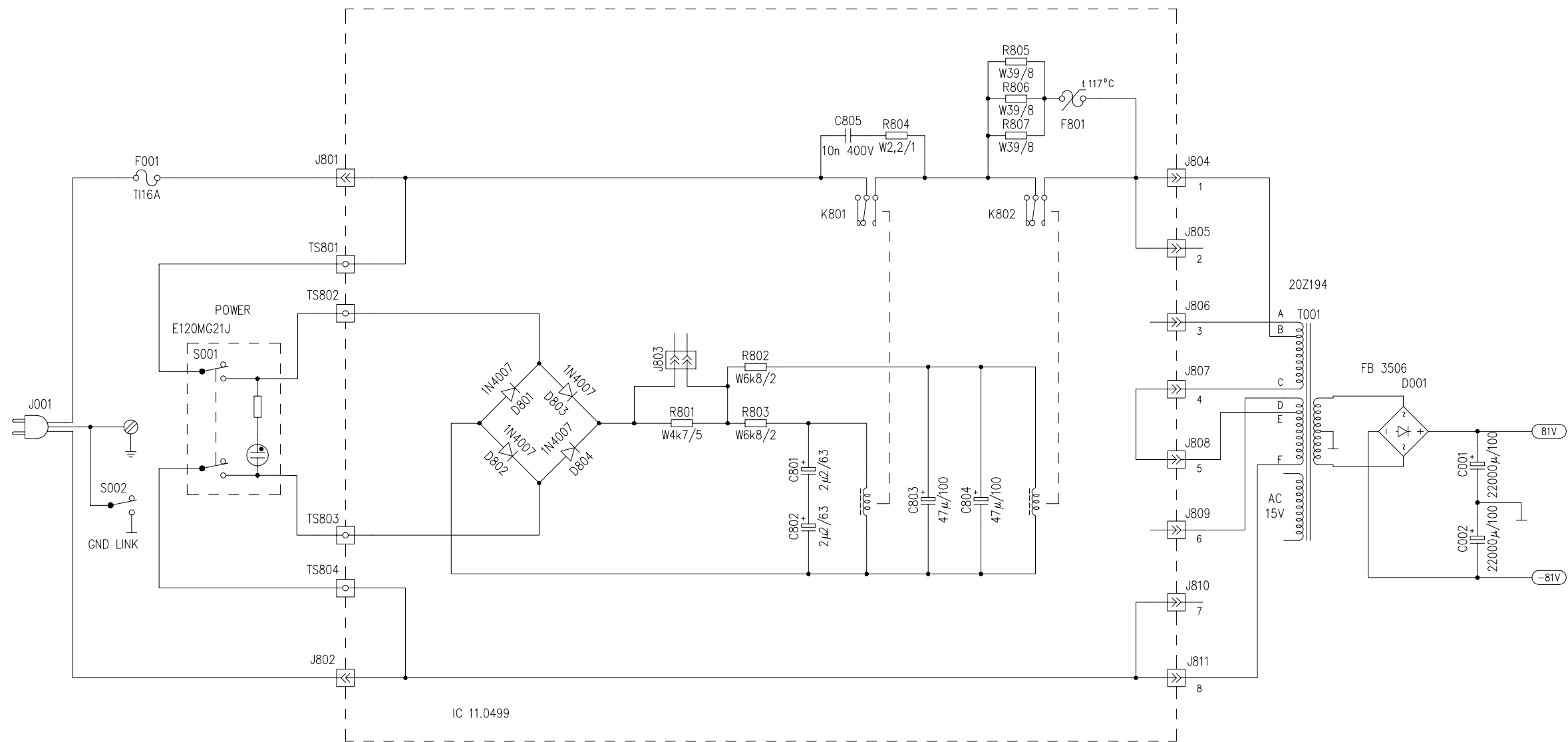

All capacitors 63 V, unless otherwise noted.
 Resistors in Ohms. Capacitors in Farads. Inductors in Henries.
 All resistors 1/4 W, unless otherwise noted.
 See parts list for more information about components.

Special schematic abbreviations:
 W wounded wire resistor
 C ceramic capacitor

110 V	120 V	220 V	230 V	240 V
1 - B	1 - A	1 - B	1 - A	1 - A
2 - E	2 - D	2 -	2 -	2 -
3 - A	3 - B	3 - A	3 - B	3 - B
4 -	4 -	4 - C	4 - C	4 - C
5 -	5 -	5 - E	5 - E	5 - D
6 - D	6 - E	6 - D	6 - D	6 - E
7 - C	7 - C	7 -	7 -	7 -
8 - F	8 - F	8 - F	8 - F	8 - F

MINI-JUMPER
 J803 ON

MINI-JUMPER
 J803 OFF

TITLE: SOFT START AND POWER CIRCUIT		MODEL: PAM1000	 LABORATORIO DE ELECTRO-ACUSTICA BARCELONA ESPAÑA	
DRAWN: J.QUERALT		SHEET 1 OF 6		
DATE: 011093	REPLACES:	DRW. NO. 10.0234	REV.	
CHECKED:	DATE:	REPLACED BY:		

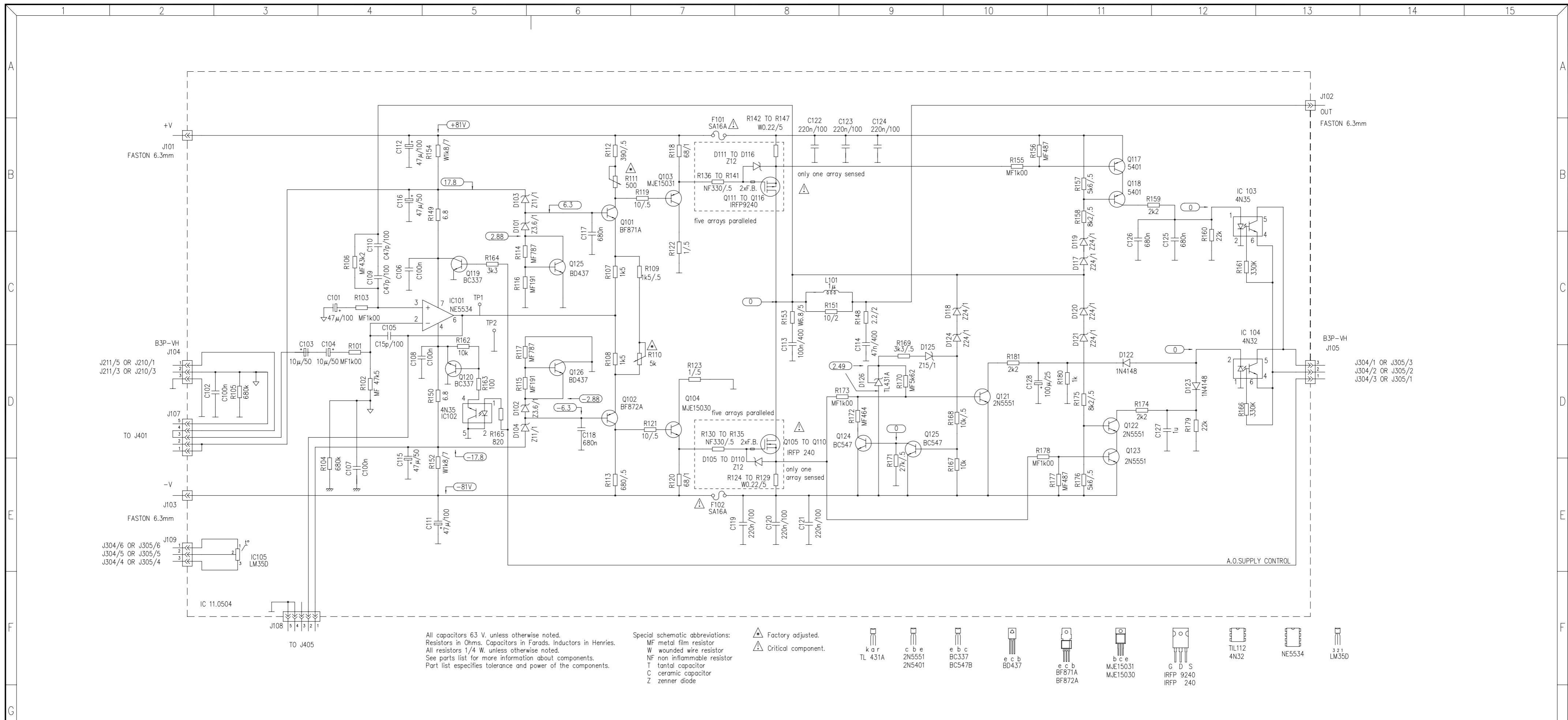

TITLE: POWER CIRCUIT AND SHORT CIRCUIT PROTECTION SCHEMATIC DIAGRAM

DRAWN: J.QUERALT DATE: 300993

CHECKED: DATE:

MODEL: PAM 1000 Switching Mosfet Power Amplifier

SHEET 2 OF 6

REPLACES:

REPLACED BY:

ECLEROO
LABORATORIO DE ELECTRO-ACUSTICA ESPAÑA

DRW. NO. 10.0229 REV. A

NOTE: R109 have been changed from 1k/5 to 1k5/5

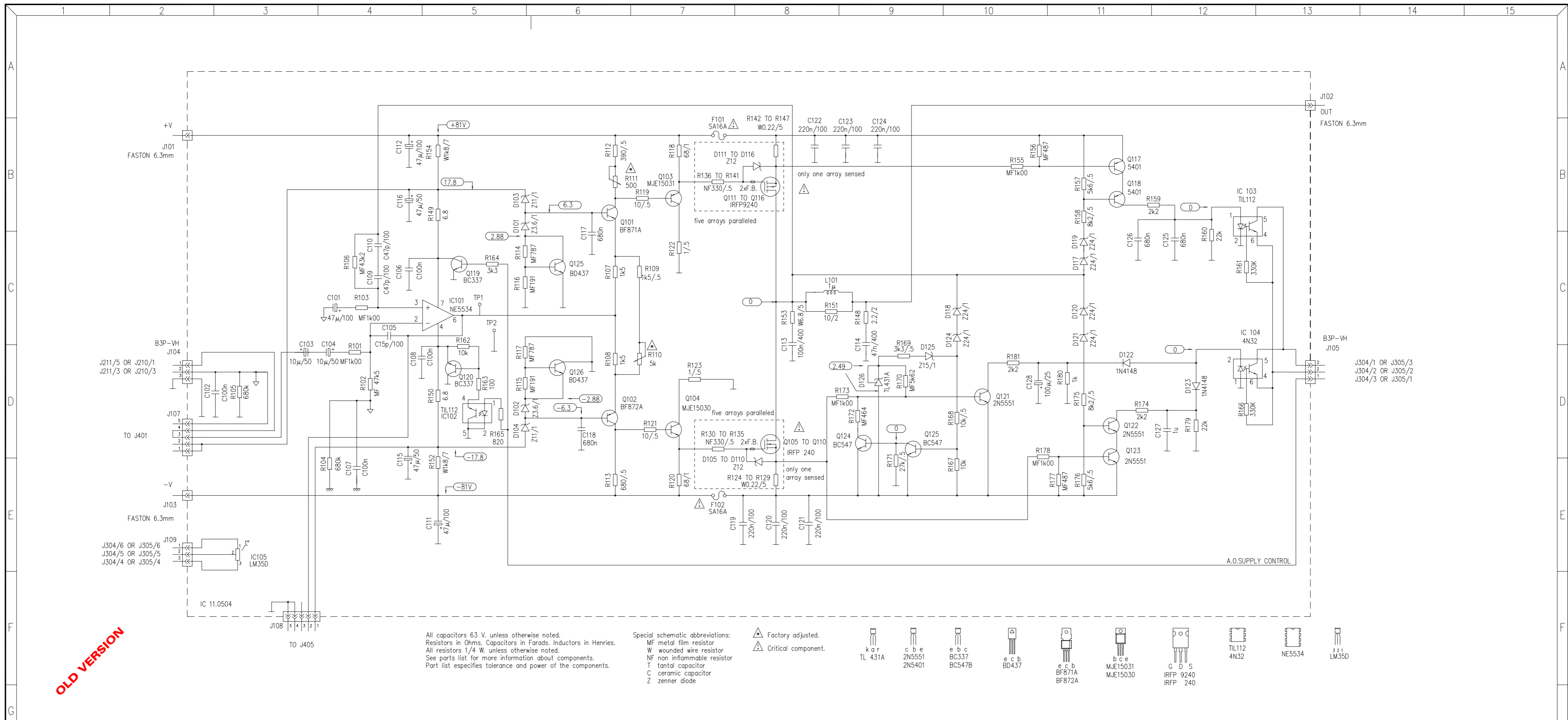

All capacitors 63 V, unless otherwise noted.
Resistors in Ohms. Capacitors in Farads. Inductors in Henries.
All resistors 1/4 W, unless otherwise noted.
See parts list for more information about components.
Part list specifies tolerance and power of the components.

Special schematic abbreviations:
MF metal film resistor
W wounded wire resistor
NF non inflammable resistor
T tantal capacitor
C ceramic capacitor
Z zener diode

▲ Factory adjusted.
▲ Critical component.

- kar TL 431A
- c b e 2N5551
- e b c BC337
- e c b BC547B
- e c b BD437
- e c b BF871A
- b c e MJE15031
- G D S IRFP 9240
- IRFP 240
- TIL112 4N32
- NE5534
- 3 2 1 LM350

NOTE: R109 have been changed from 1k/.5 to 1k5/.5

OLD VERSION

TITLE: POWER CIRCUIT AND SHORT CIRCUIT PROTECTION SCHEMATIC DIAGRAM		MODEL: PAM 1000 Switching Mosfet Power Amplifier		 LABORATORIO DE ELECTRO-ACUSTICA ESPAÑA
DRAWN: J.QUERALT		DATE: 300993		
CHECKED:		DATE:		REPLACES:
				REPLACED BY:
				DRW. NO. 10.0229
				REV.

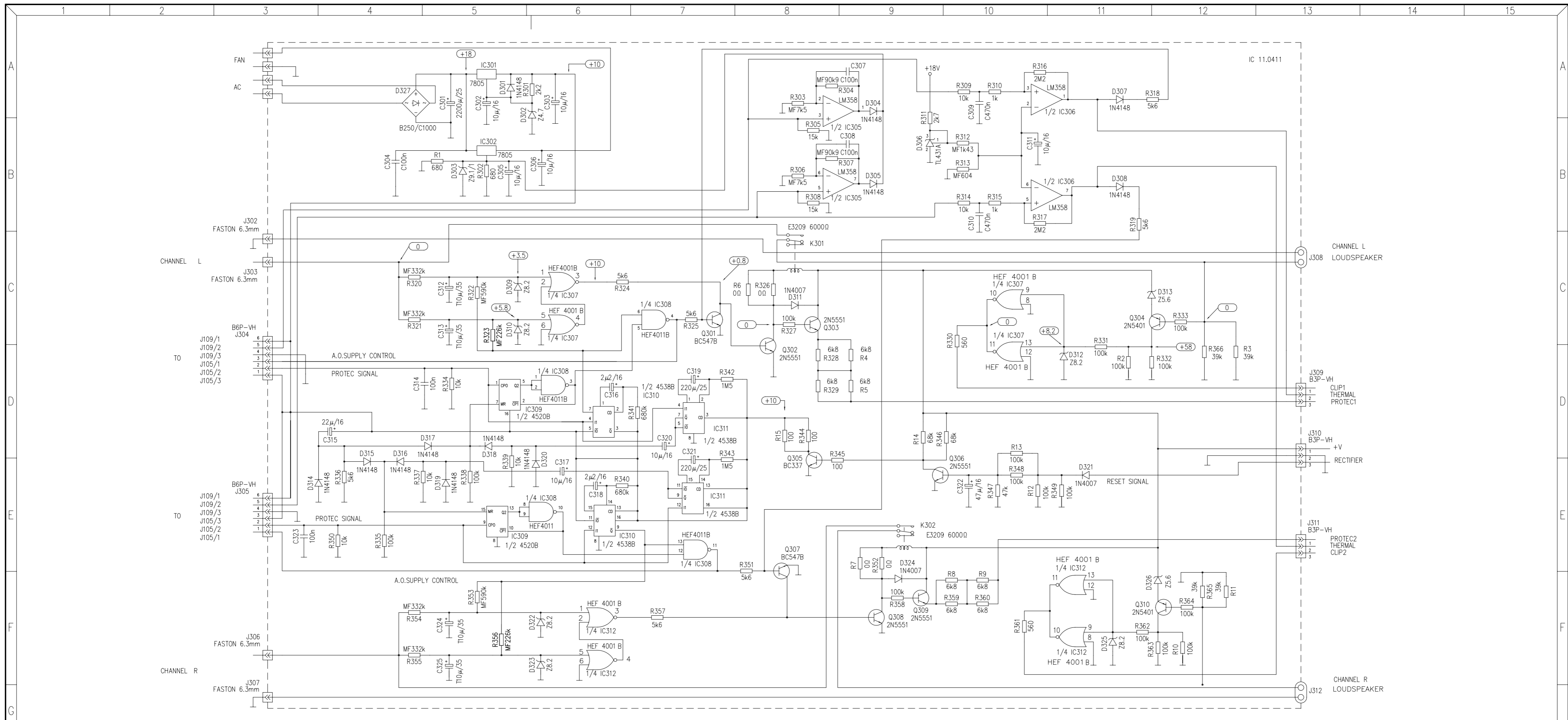



TITLE: PROTECTIONS CIRCUIT		MODEL: PAM1000 Switching Power Mosfet Amplifier	 LABORATORIO DE ELECTRO-ACUSTICA BARCELONA ESPAÑA
DRAWN: J.QUERALT		SHEET 6 OF 6	
DATE: 071093	REPLACES:	DRW. NO. 10.0236	REV.
CHECKED:	REPLACED BY:		

All capacitors 63 V, unless otherwise noted.
 Resistors in Ohms, Capacitors in Farads, Inductors in Henries.
 All resistors 1/4 W, unless otherwise noted.
 See parts list for more information about components.
 Part list specifies tolerance and power of the components.

Special schematic abbreviations:
 MF metal film resistor 1%
 W wounded wire resistor
 T tantal capacitor
 C ceramic capacitor
 Z zener diode

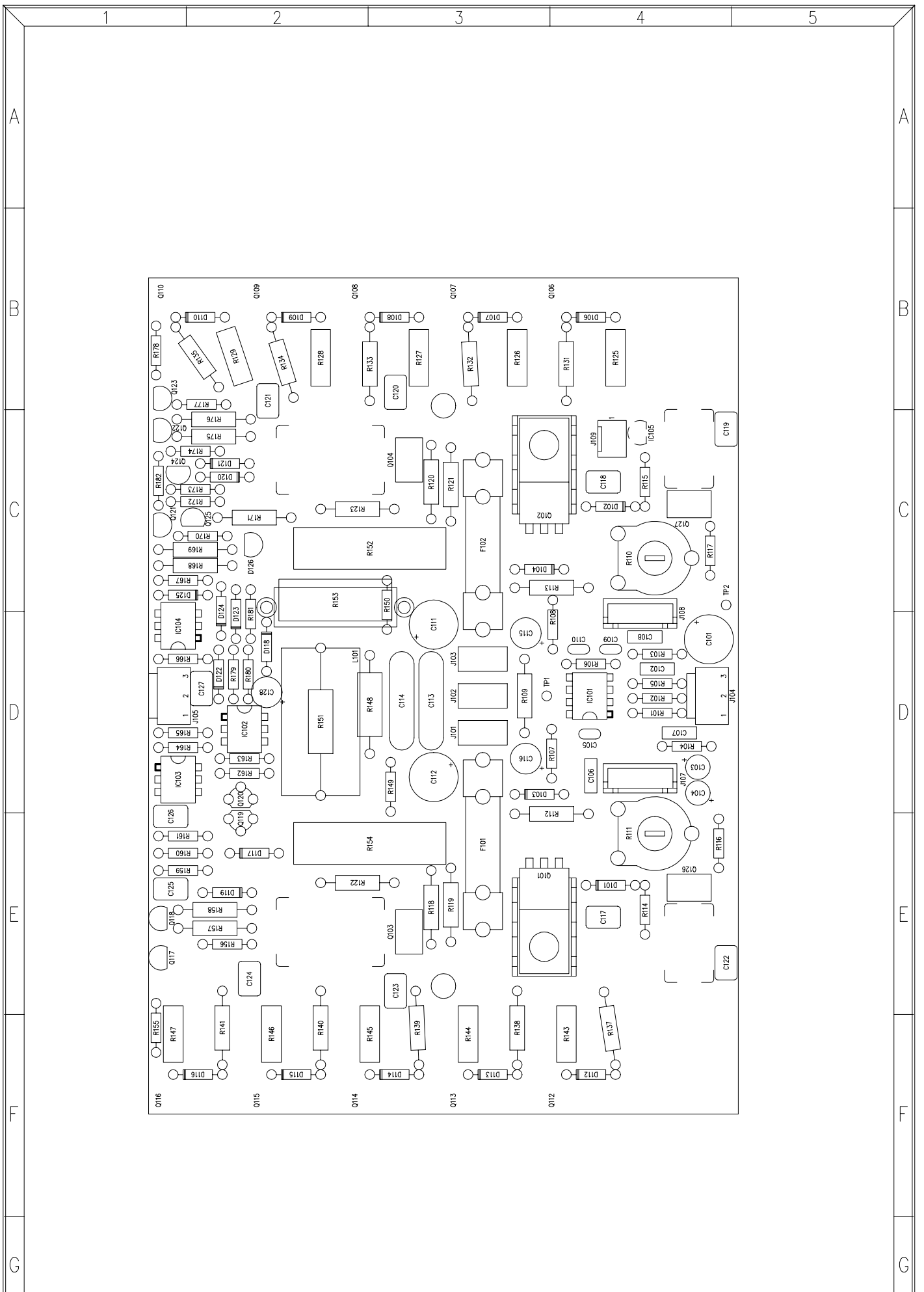



TITLE: POWER CIRCUIT AND SHORT CIRCUIT PROTECTION		MODEL: PAM1000		 LABORATORIO DE ELECTRO-ACUSTICA BARCELONA ESPAÑA	
DRAWN: J.QUERALT		SHEET 1 OF 7			
DATE: 081193		REPLACES:		DRW. NO.	REV.
CHECKED:		REPLACED BY:		33.0008 R/	C

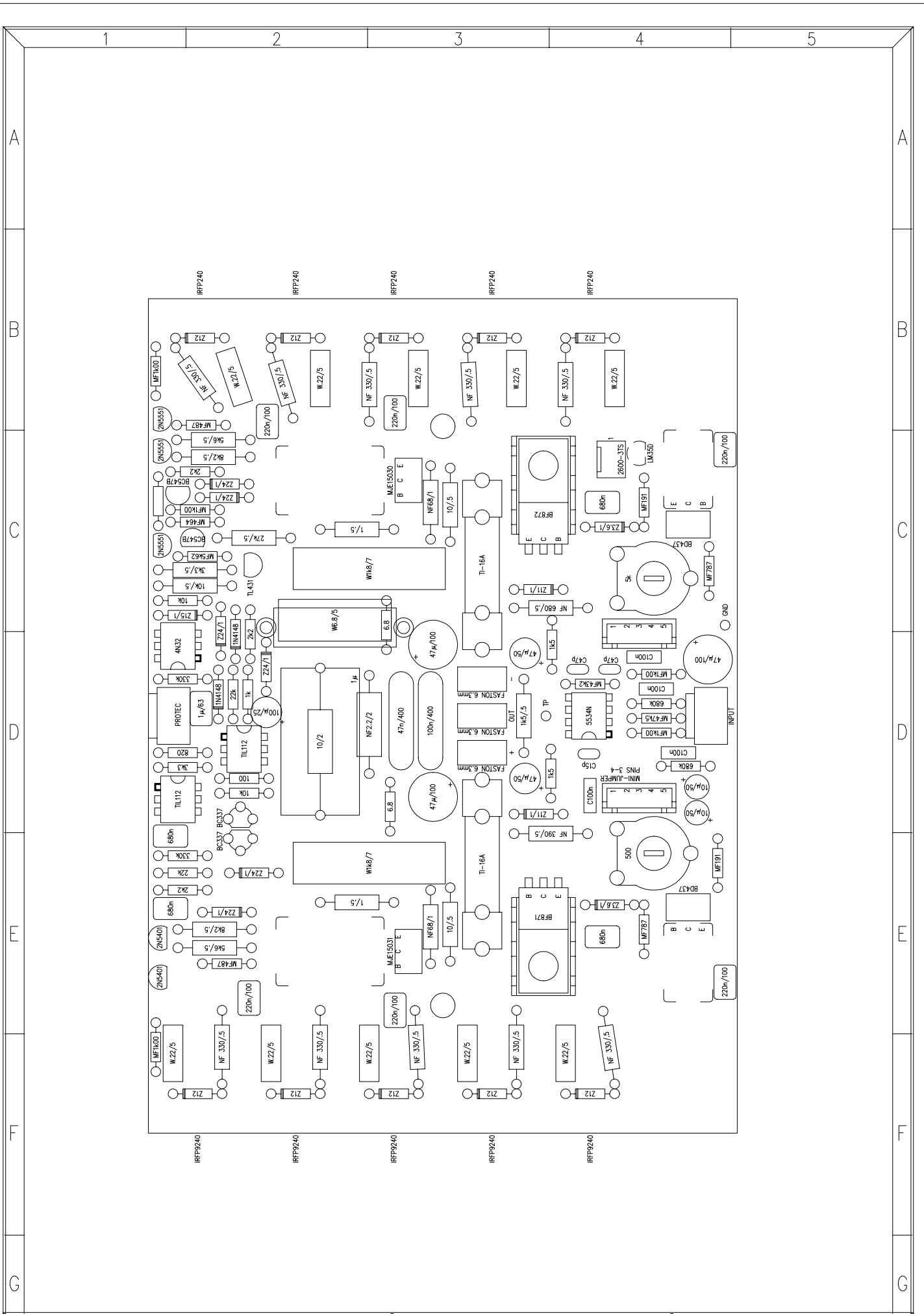

TITLE: POWER CIRCUIT AND SHORT CIRCUIT PROTECTION		MODEL: PAM1000		 LABORATORIO DE ELECTRO-ACUSTICA BARCELONA ESPAÑA	
DRAWN: J.QUERALT		SHEET 1 OF 7			
DATE: 081193		REPLACES:		DRW. NO.	
CHECKED:		REPLACED BY:		33.0008 V/	
DATE:				REV. C	

PARTS LIST:
MODEL : PAM1000
DATE: 000621

POWER CIRCUIT AND SHORT CIRCUIT PROTECTION
DRW. No 33.0008PL
SHEET 1 OF 4 REPLACES: REV: A
REPLACED BY:

REFERENCE	VALUE
C101	47μ/100
C102	C100n
C103	10μ/50
C104	10μ/50
C105	C15p
C106	C100n
C107	C100n
C108	C100n
C109	C47p
C110	C47p
C111	47μ/100
C112	47μ/100
C113	100n/400
C114	47n/400
C115	47μ/50
C116	47μ/50
C117	680n
C118	680n
C119	220n/100
C120	220n/100
C121	220n/100
C122	220n/100
C123	220n/100
C124	220n/100
C125	680n
C126	680n
C127	1μ/63
C128	100μ/25
CTO 11.0504	CTO.FRA.CU.
D101	Z3.6/1
D102	Z3.6/1
D103	Z11/1
D104	Z11/1
D106	Z12
D107	Z12
D108	Z12
D109	Z12
D110	Z12
D112	Z12
D113	Z12
D114	Z12
D115	Z12
D116	Z12
D117	Z24/1
D118	Z24/1
D119	Z24/1
D120	Z24/1
D121	Z24/1
D122	1N4148
D123	1N4148
D124	Z24/1
D125	Z15/1
D126	TL431
F101	TI-16A
F102	TI-16A
IC101	5534N

PARTS LIST:
MODEL : PAM1000
DATE: 000621

POWER CIRCUIT AND SHORT CIRCUIT PROTECTION
DRW. No 33.0008PL
SHEET 2 OF 4 REPLACES: REV: A
REPLACED BY:

REFERENCE	VALUE
IC102	4N35
IC103	4N35
IC104	4N32
IC105	LM35D
J101	FASTON 6.3mm
J102	FASTON 6.3mm
J103	FASTON 6.3mm
J104	B3P-VH
J105	B3P-VH
J107	B5B-XH
J108	B5B-XH
J109	2600-3TS
Q101	BF871
Q102	BF872
Q103	MJE15031
Q104	MJE15030
Q106	IRFP240
Q107	IRFP240
Q108	IRFP240
Q109	IRFP240
Q110	IRFP240
Q112	IRFP9240
Q113	IRFP9240
Q114	IRFP9240
Q115	IRFP9240
Q116	IRFP9240
Q117	2N5401
Q118	2N5401
Q119	BC337
Q120	BC337
Q121	2N5551
Q122	2N5551
Q123	2N5551
Q124	BC547B
Q125	BC547B
Q126	BD437
Q127	BD437
R101	MF1k00
R102	MF47k5
R103	MF1k00
R104	680k
R105	680k
R106	MF43k2
R107	1k5
R108	1k5
R109	1k5/.5
R110	5k
R111	500O
R112	NF 390O/.5
R113	NF 680O/.5
R114	MF787O
R115	MF191O
R116	MF191O
R117	MF787O
R118	NF68O/1
R119	10O/.5

PARTS LIST:
MODEL : PAM1000
DATE: 000621

POWER CIRCUIT AND SHORT CIRCUIT PROTECTION
DRW. No 33.0008PL
SHEET 3 OF 4 REPLACES: REV: A
REPLACED BY:

REFERENCE	VALUE
R120	NF68/1
R121	100/.5
R122	10/.5
R123	10/.5
R125	W.220/5
R126	W.220/5
R127	W.220/5
R128	W.220/5
R129	W.220/5
R131	NF3300/.5
R132	NF3300/.5
R133	NF3300/.5
R134	NF3300/.5
R135	NF3300/.5
R137	NF3300/.5
R138	NF3300/.5
R139	NF3300/.5
R140	NF3300/.5
R141	NF3300/1
R143	W.220/5
R144	W.220/5
R145	W.220/5
R146	W.220/5
R147	W.220/5
R148	NF2.20/2
R149	6.80
R150	6.80
R151	100/2
R152	W1k8/7
R153	W6.8/5
R154	W1k8/7
R155	MF1k00
R156	MF487
R157	5k6/.5
R158	8k2/.5
R159	2k2
R160	22k
R161	330k
R162	10k
R163	1000
R164	3k3
R165	820
R166	330k
R167	10k
R168	10k/.5
R169	3k3/.5
R170	MF5k62
R171	27k/.5
R172	MF464
R173	MF1k00
R174	2k2
R175	8k2/.5
R176	5k6/.5
R177	MF487
R178	MF1k00
R179	22k

PARTS LIST:
MODEL : PAM1000
DATE: 000621

POWER CIRCUIT AND SHORT CIRCUIT PROTECTION
DRW. No 33.0008PL
SHEET 4 OF 4 REPLACES: REV: A
REPLACED BY:

REFERENCE

VALUE

R180
R181

1k
2k2

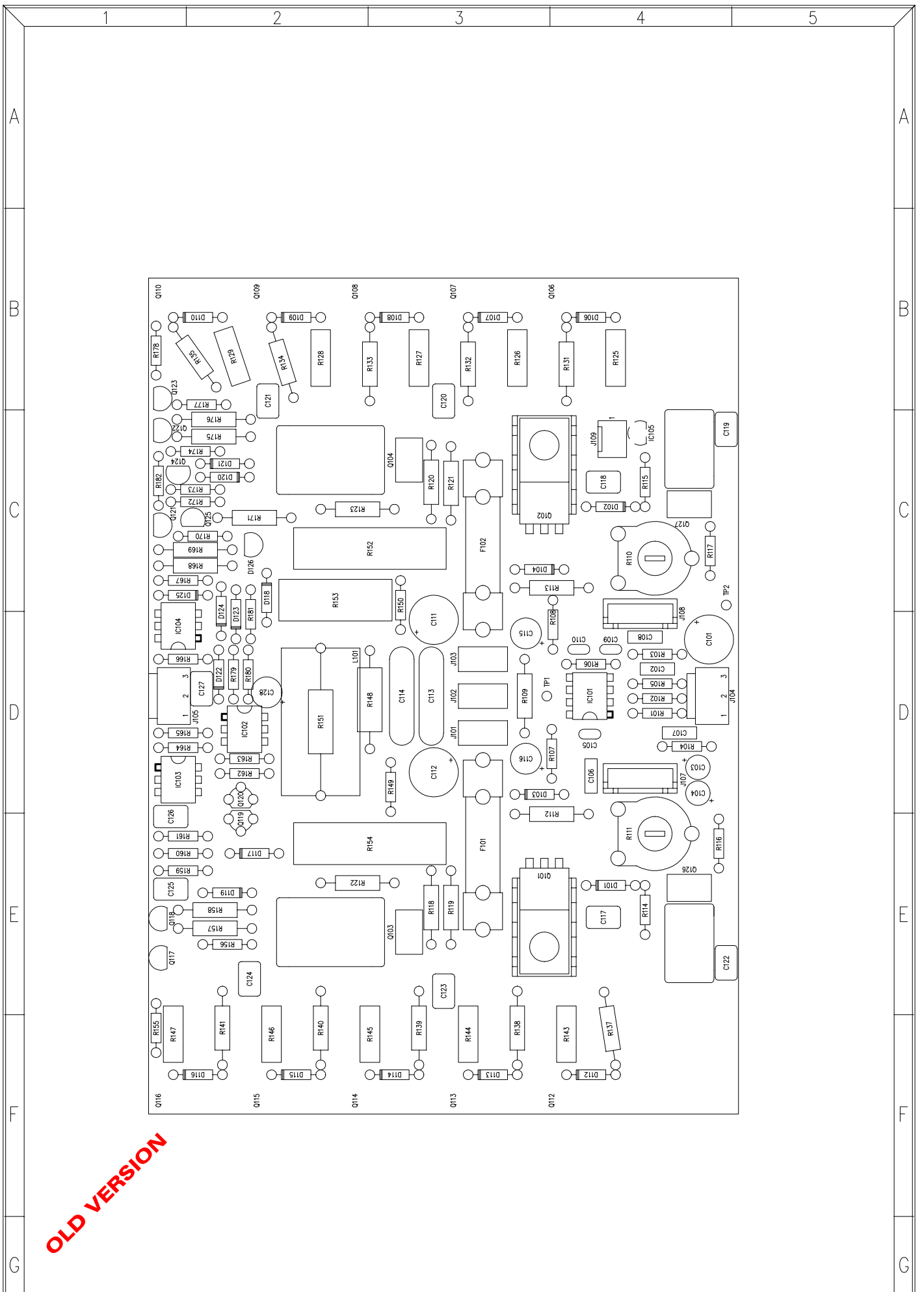

OLD VERSION

TITLE: POWER CIRCUIT AND SHORT CIRCUIT PROTECTION		MODEL: PAM1000		 LABORATORIO DE ELECTRO-ACUSTICA BARCELONA ESPAÑA	
DRAWN: J.QUERALT		DATE: 081193		SHEET 1 OF 7	
CHECKED:		DATE:		REPLACES:	
				REPLACED BY:	
				DRW. NO. 33.0008 R/	
				REV. A	

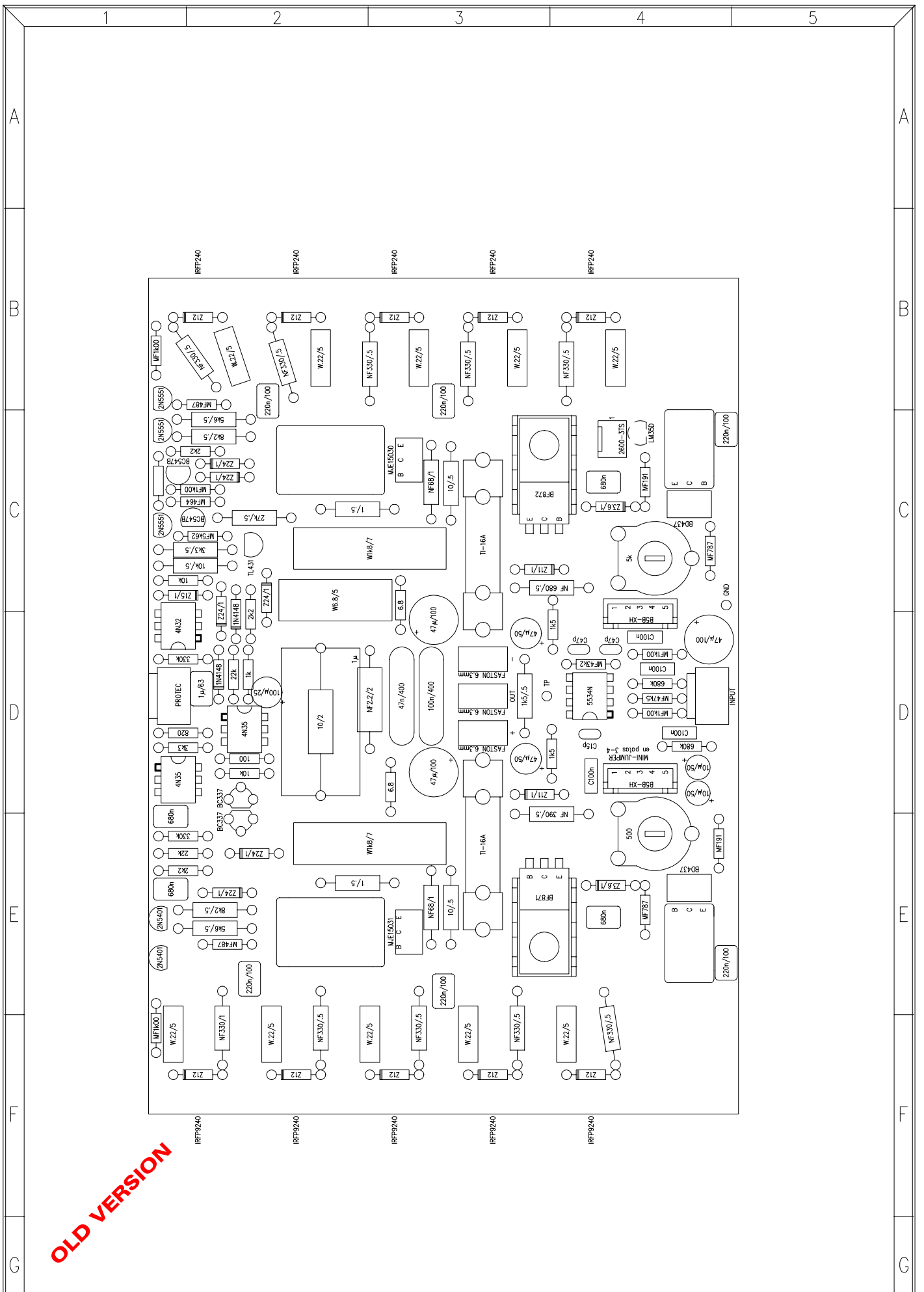

TITLE: POWER CIRCUIT AND SHORT CIRCUIT PROTECTION		MODEL: PAM1000		ECLEREO	
DRAWN: J.QUERALT		DATE: 081193		LABORATORIO DE ELECTRO-ACUSTICA BARCELONA ESPAÑA	
CHECKED:		DATE:		REPLACES:	
				REPLACED BY:	
				DRW. NO. 33.0008 V/	
				REV. A	

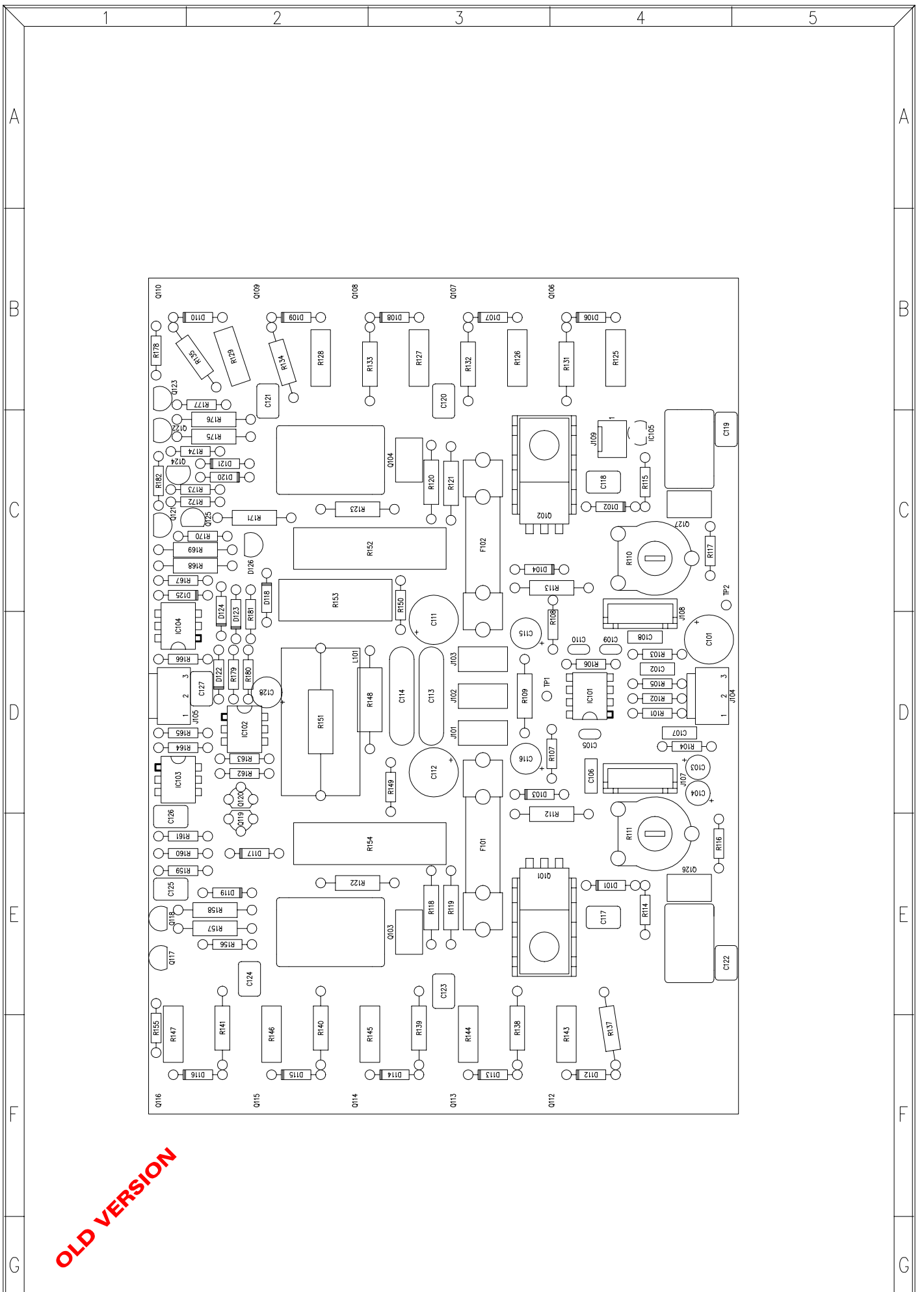

OLD VERSION

TITLE: POWER CIRCUIT AND SHORT CIRCUIT PROTECTION		MODEL: PAM1000		 LABORATORIO DE ELECTRO-ACUSTICA BARCELONA ESPAÑA	
DRAWN: J.QUERALT		SHEET 1 OF 7			
DATE: 081193		REPLACES:		DRW. NO.	REV.
CHECKED:		REPLACED BY:		33.0008 R/	

PARTS LIST:
MODEL : PAM1000
DATE: 081193

POWER CIRCUIT AND SHORT CIRCUIT PROTECTION

DRW. No 33.0008PL
SHEET 1 OF 4 REPLACES:

REV:
REPLACED BY:

REFERENCE	VALUE
C101	47μ/100
C102	C100n
C103	10μ/50
C104	10μ/50
C105	C15p
C106	C100n
C107	C100n
C108	C100n
C109	C47p
C110	C47p
C111	47μ/100
C112	47μ/100
C113	100n/400
C114	47n/400
C115	47μ/50
C116	47μ/50
C117	680n
C118	680n
C119	220n/100
C120	220n/100
C121	220n/100
C122	220n/100
C123	220n/100
C124	220n/100
C125	680n
C126	680n
C127	1μ/63
C128	100μ/25
CTO 11.0504	CTO.FRA.CU.
D101	Z3.6/1
D102	Z3.6/1
D103	Z11/1
D104	Z11/1
D106	Z12
D107	Z12
D108	Z12
D109	Z12
D110	Z12
D112	Z12
D113	Z12
D114	Z12
D115	Z12
D116	Z12
D117	Z24/1
D118	Z24/1
D119	Z24/1
D120	Z24/1
D121	Z24/1
D122	1N4148
D123	1N4148
D124	Z24/1
D125	Z15/1
D126	TL431
F101	TI-16A
F102	TI-16A
IC101	5534N

OLD VERSION

PARTS LIST:
MODEL : PAM1000
DATE: 081193

POWER CIRCUIT AND SHORT CIRCUIT PROTECTION

DRW. No 33.0008PL
SHEET 2 OF 4 REPLACES:

REV:
REPLACED BY:

REFERENCE	VALUE
IC102	TIL112
IC103	TIL112
IC104	4N32
IC105	LM35D
J101	FASTON 6.3mm
J102	FASTON 6.3mm
J103	FASTON 6.3mm
J104	B3P-VH
J105	B3P-VH
J107	B5B-XH
J108	B5B-XH
J109	2600-3TS
Q101	BF871
Q102	BF872
Q103	MJE15031
Q104	MJE15030
Q106	IRFP240
Q107	IRFP240
Q108	IRFP240
Q109	IRFP240
Q110	IRFP240
Q112	IRFP9240
Q113	IRFP9240
Q114	IRFP9240
Q115	IRFP9240
Q116	IRFP9240
Q117	2N5401
Q118	2N5401
Q119	BC337
Q120	BC337
Q121	2N5551
Q122	2N5551
Q123	2N5551
Q124	BC547B
Q125	BC547B
Q126	BD437
Q127	BD437
R101	MF1k00
R102	MF47k5
R103	MF1k00
R104	680k
R105	680k
R106	MF43k2
R107	1k5
R108	1k5
R109	1k5/.5
R110	5k
R111	500O
R112	NF 390O/.5
R113	NF 680O/.5
R114	MF787O
R115	MF191O
R116	MF191O
R117	MF787O
R118	NF68O/1
R119	10O/.5

OLD VERSION

PARTS LIST:
MODEL : PAM1000
DATE: 081193

POWER CIRCUIT AND SHORT CIRCUIT PROTECTION
DRW. No 33.0008PL
SHEET 3 OF 4 REPLACES: REV:
REPLACED BY:

REFERENCE	VALUE
R120	NF68/1
R121	100/.5
R122	10/.5
R123	10/.5
R125	W.220/5
R126	W.220/5
R127	W.220/5
R128	W.220/5
R129	W.220/5
R131	NF3300/.5
R132	NF3300/.5
R133	NF3300/.5
R134	NF3300/.5
R135	NF3300/.5
R137	NF3300/.5
R138	NF3300/.5
R139	NF3300/.5
R140	NF3300/.5
R141	NF3300/1
R143	W.220/5
R144	W.220/5
R145	W.220/5
R146	W.220/5
R147	W.220/5
R148	NF2.20/2
R149	6.80
R150	6.80
R151	100/2
R152	W1k8/7
R153	W6.8/5
R154	W1k8/7
R155	MF1k00
R156	MF487
R157	5k6/.5
R158	8k2/.5
R159	2k2
R160	22k
R161	330k
R162	10k
R163	1000
R164	3k3
R165	820
R166	330k
R167	10k
R168	10k/.5
R169	3k3/.5
R170	MF5k62
R171	27k/.5
R172	MF464
R173	MF1k00
R174	2k2
R175	8k2/.5
R176	5k6/.5
R177	MF487
R178	MF1k00
R179	22k

OLD VERSION

PARTS LIST:
MODEL : PAM1000
DATE: 081193

POWER CIRCUIT AND SHORT CIRCUIT PROTECTION
DRW. No 33.0008PL
SHEET 4 OF 4 REPLACES: REV:
REPLACED BY:

REFERENCE	VALUE
R180	1k
R181	2k2

OLD VERSION

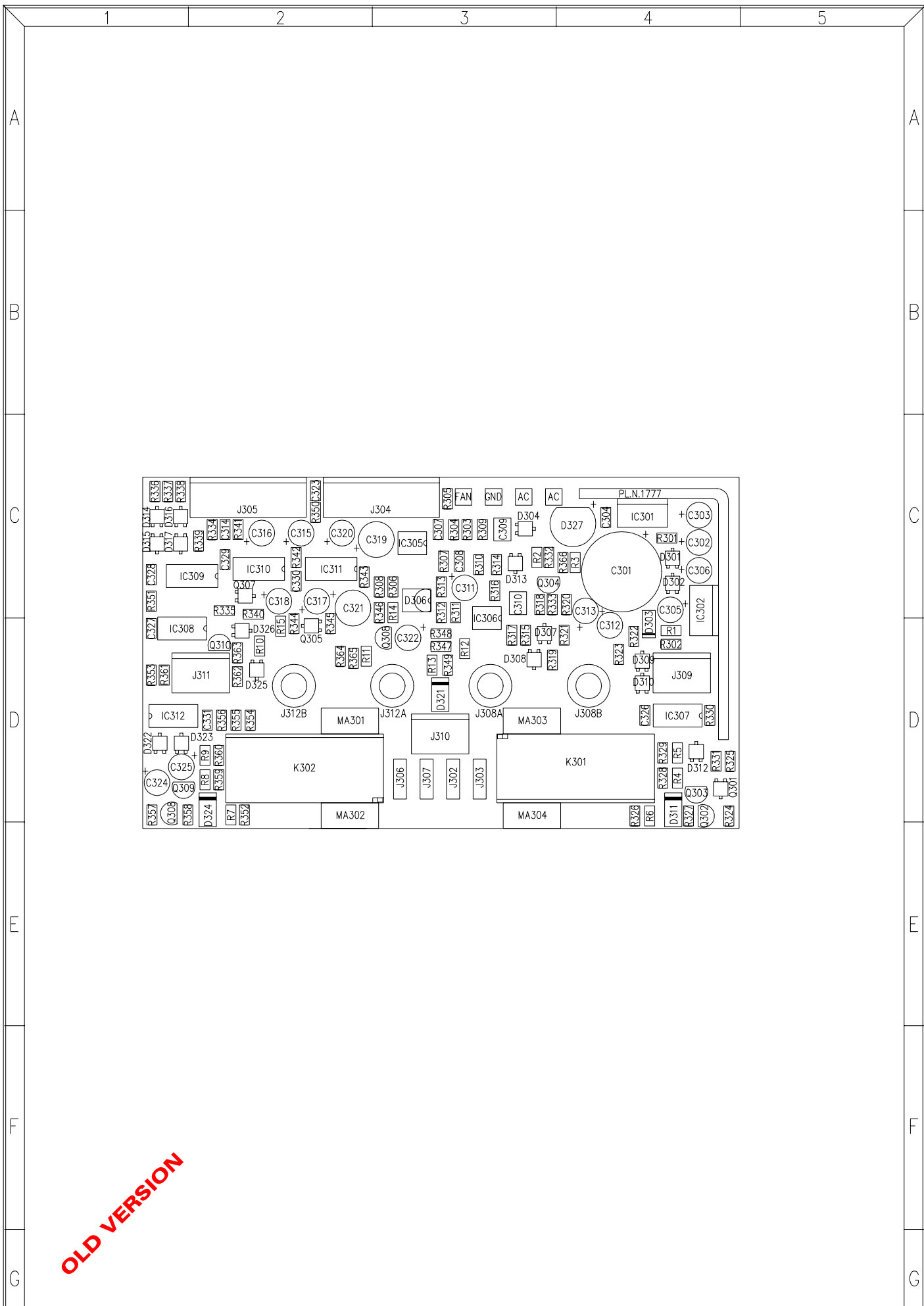

OLD VERSION

TITLE: PROTECTIONS CIRCUIT		MODEL: PAM1000		 LABORATORIO DE ELECTRO-ACUSTICA BARCELONA ESPAÑA	
DRAWN: J.QUERALT		SHEET 7 OF 7			
DATE: 241293		REPLACES:		DRW. NO.	REV.
CHECKED:		REPLACED BY:		33.0014 R/	

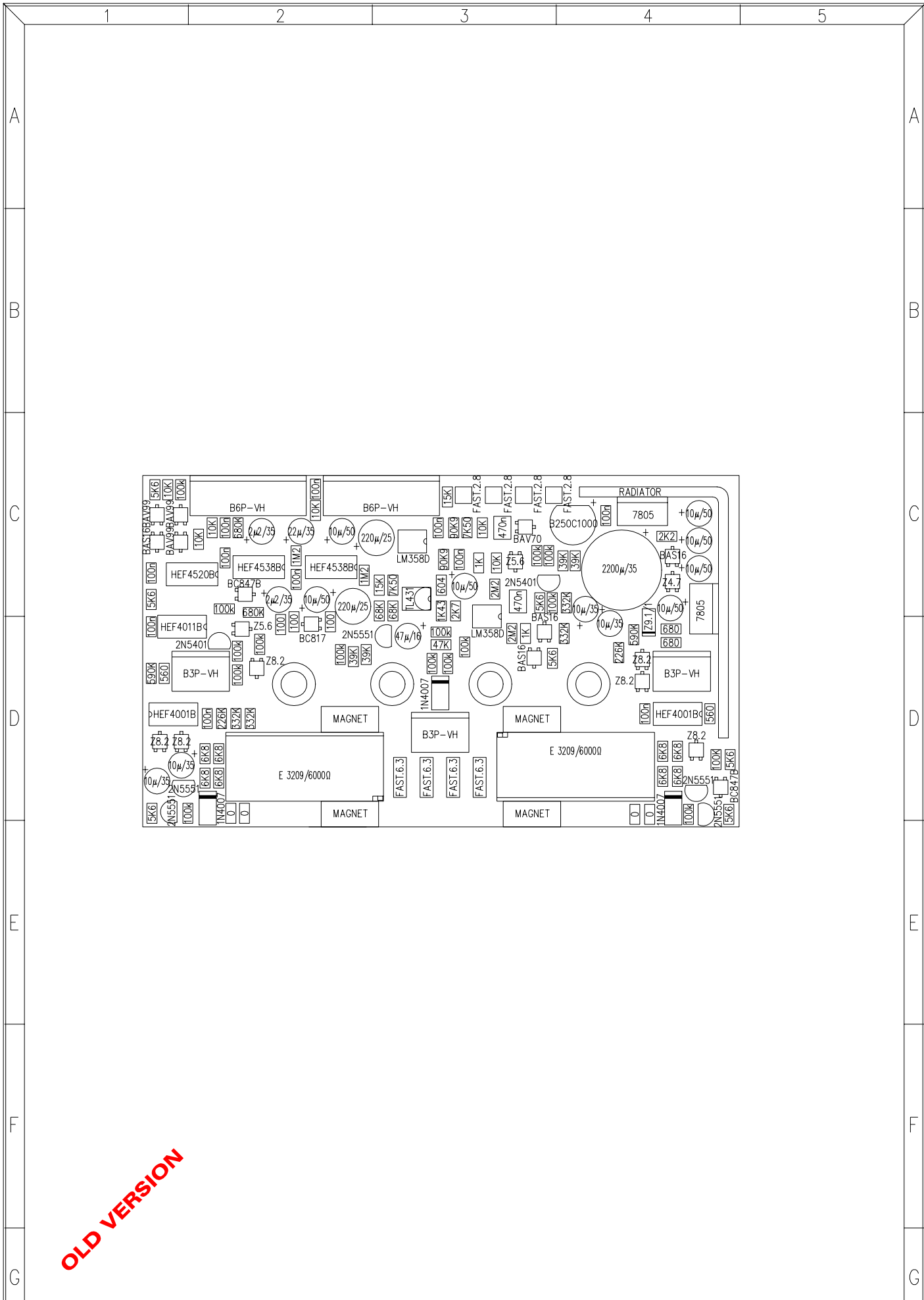

OLD VERSION

TITLE: PROTECTIONS CIRCUIT		MODEL: PAM1000		 LABORATORIO DE ELECTRO-ACUSTICA BARCELONA ESPAÑA	
		SHEET 7 OF 7			
DRAWN: J.QUERALT	DATE: 241293	REPLACES:		DRW. NO. 33.0014	REV. V
CHECKED:	DATE:	REPLACED BY:			

PARTS LIST:
MODEL : PAM1000
DATE: 241293

PROTECTIONS CIRCUIT
DRW. No 33.0014PL
SHEET 1 OF 4 REPLACES:

REV:
REPLACED BY:

REFERENCE	VALUE
AC	FAST.2.8
AC	FAST.2.8
C301	2200 μ /35
C302	10 μ /50
C303	10 μ /50
C304	100n
C305	10 μ /50
C306	10 μ /50
C307	100n
C308	100n
C309	470n
C310	470n
C311	10 μ /50
C312	10 μ /35
C313	10 μ /35
C314	100n
C315	22 μ /35
C316	2 μ 2/35
C317	10 μ /50
C318	2 μ 2/35
C319	220 μ /25
C320	10 μ /50
C321	220 μ /25
C322	47 μ /16
C323	100n
C324	10 μ /35
C325	10 μ /35
C326	100n
C327	100n
C328	100n
C329	100n
C330	100n
C331	100n
D301	BAS16
D302	Z4.7
D303	Z9.1/1
D304	BAV70
D306	TL431
D307	BAS16
D308	BAS16
D309	Z8.2
D310	Z8.2
D311	1N4007
D312	Z8.2
D313	Z5.6
D314	BAV99
D315	BAS16
D316	BAV99
D317	BAV99
D321	1N4007
D322	Z8.2
D323	Z8.2
D324	1N4007
D325	Z8.2
D326	Z5.6
D327	B250C1000

OLD VERSION

PARTS LIST:
MODEL : PAM1000
DATE: 241293

PROTECTIONS CIRCUIT
DRW. No 33.0014PL
SHEET 2 OF 4 REPLACES:

REV:
REPLACED BY:

REFERENCE	VALUE
FAN	FAST.2.8
GND	FAST.2.8
IC301	7805
IC302	7805
IC305	LM358D
IC306	LM358D
IC307	HEF4001B
IC308	HEF4011B
IC309	HEF4520B
IC310	HEF4538B
IC311	HEF4538B
IC312	HEF4001B
INSULANT WASHER	R19
INSULANT WASHER	R19
J302	FAST.6.3
J303	FAST.6.3
J304	B6P-VH
J305	B6P-VH
J306	FAST.6.3
J307	FAST.6.3
J309	B3P-VH
J310	B3P-VH
J311	B3P-VH
K301	E 3209/6000Ω
K302	E 3209/6000Ω
MA301	MAGNET
MA302	MAGNET
MA303	MAGNET
MA304	MAGNET
NUT	M3
NUT	M3
PL.N.1777	RADIATOR
Q301	BC847B
Q302	2N5551
Q303	2N5551
Q304	2N5401
Q305	BC817
Q307	BC847B
Q308	2N5551
Q308	2N5551
Q309	2N5551
Q310	2N5401
R1	680
R10	100k
R11	39K
R12	100k
R13	100k
R14	68K
R15	100
R2	100k
R3	39K
R301	2K2
R302	680
R303	7K50
R304	90K9
R305	15K

OLD VERSION

PARTS LIST:
MODEL : PAM1000
DATE: 241293

PROTECTIONS CIRCUIT
DRW. No 33.0014PL
SHEET 3 OF 4 REPLACES:

REV:
REPLACED BY:

REFERENCE	VALUE
R306	7K50
R307	90K9
R308	15K
R309	10K
R310	1K
R311	2K7
R312	1K43
R313	604
R314	10K
R315	1K
R316	2M2
R317	2M2
R318	5K6
R319	5K6
R320	332K
R321	332K
R322	590K
R323	226K
R324	5K6
R325	5K6
R326	0
R327	100k
R328	6K8
R329	6K8
R330	560
R331	100K
R332	100k
R333	100k
R334	10K
R335	100k
R336	5K6
R337	10K
R338	100k
R339	10K
R340	680K
R341	680K
R342	1M2
R343	1M2
R344	100
R345	100
R346	68K
R347	47K
R348	100k
R349	100k
R350	10K
R351	5K6
R352	0
R353	590K
R354	332K
R355	332K
R356	226K
R357	5K6
R358	100k
R359	6K8
R360	6K8
R361	560

OLD VERSION

PARTS LIST:
MODEL : PAM1000
DATE: 241293

PROTECTIONS CIRCUIT
DRW. No 33.0014PL
SHEET 4 OF 4 REPLACES:

REV:
REPLACED BY:

REFERENCE	VALUE
R362	100k
R363	100k
R364	100k
R365	39K
R366	39K
R4	6K8
R5	6K8
R6	0
R7	0
R8	6K8
R9	6K8
SCREW	M3X8 DIN7985 NINE
SCREW	M3X8 DIN7985 NINE
WASHER	ADE M3
WASHER	ADE M3
PC 11.0411	PRINTED CIRCUIT

OLD VERSION

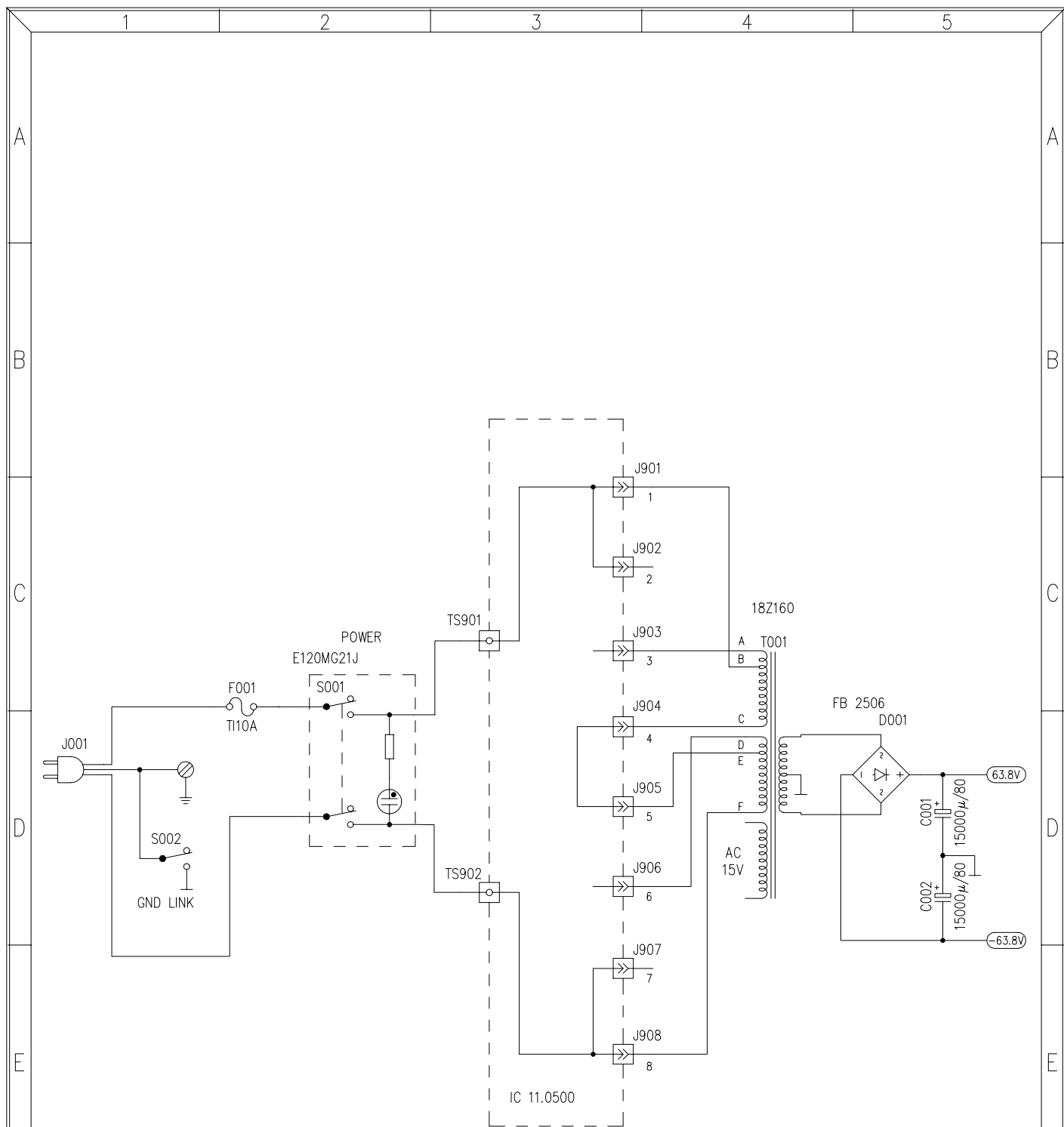

All capacitors 63 V, unless otherwise noted.
 Resistors in Ohms. Capacitors in Farads. Inductors in Henries.
 All resistors 1/4 W, unless otherwise noted.
 See parts list for more information about components.

Special schematic abbreviations:
 W wounded wire resistor
 C ceramic capacitor

	<u>110 V</u>	<u>120 V</u>	<u>220 V</u>	<u>230 V</u>	<u>240 V</u>
1 -	B	A	B	A	A
2 -	E	D	-	-	-
3 -	A	B	A	B	B
4 -	-	-	C	C	C
5 -	-	-	E	E	D
6 -	D	E	D	D	E
7 -	C	C	-	-	-
8 -	F	F	F	F	F

TITLE: POWER CIRCUIT		MODEL: PAM600		 LABORATORIO DE ELECTRO-ACUSTICA BARCELONA ESPAÑA	
DRAWN: J.QUERALT		SHEET 1 OF 6			
DATE: 011093		REPLACES:		DRW. NO. 10.0235	
CHECKED:		REPLACED BY:		REV.	

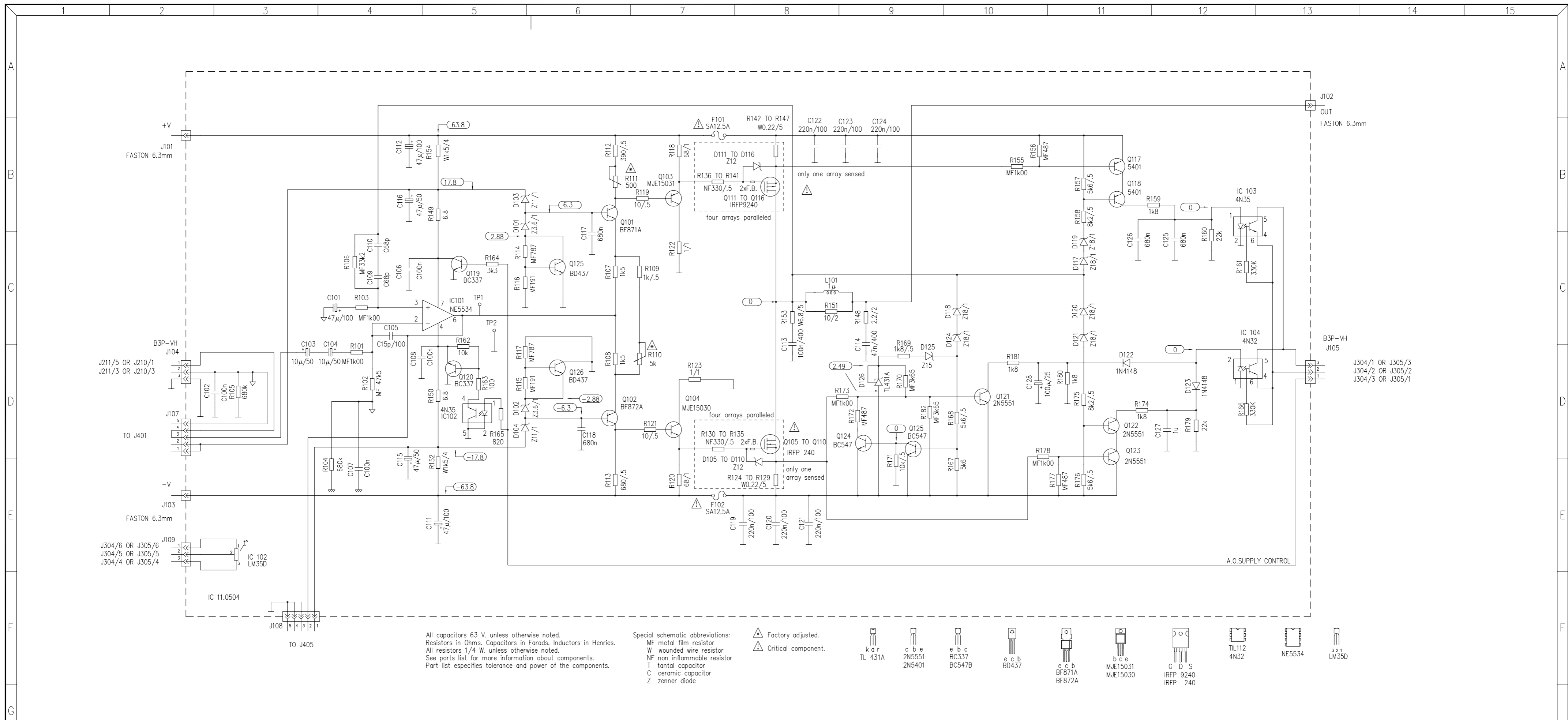

TITLE: POWER CIRCUIT AND SHORT CIRCUIT PROTECTION SCHEMATIC DIAGRAM		MODEL: PAM 600 Switching Mosfet Power Amplifier		 LABORATORIO DE ELECTRO-ACUSTICA ESPAÑA	
DRAWN: J.QUERALT		DATE: 071093			
CHECKED:		DATE:		REPLACES:	DRW. NO. 10.0238
				REPLACED BY:	REV. A

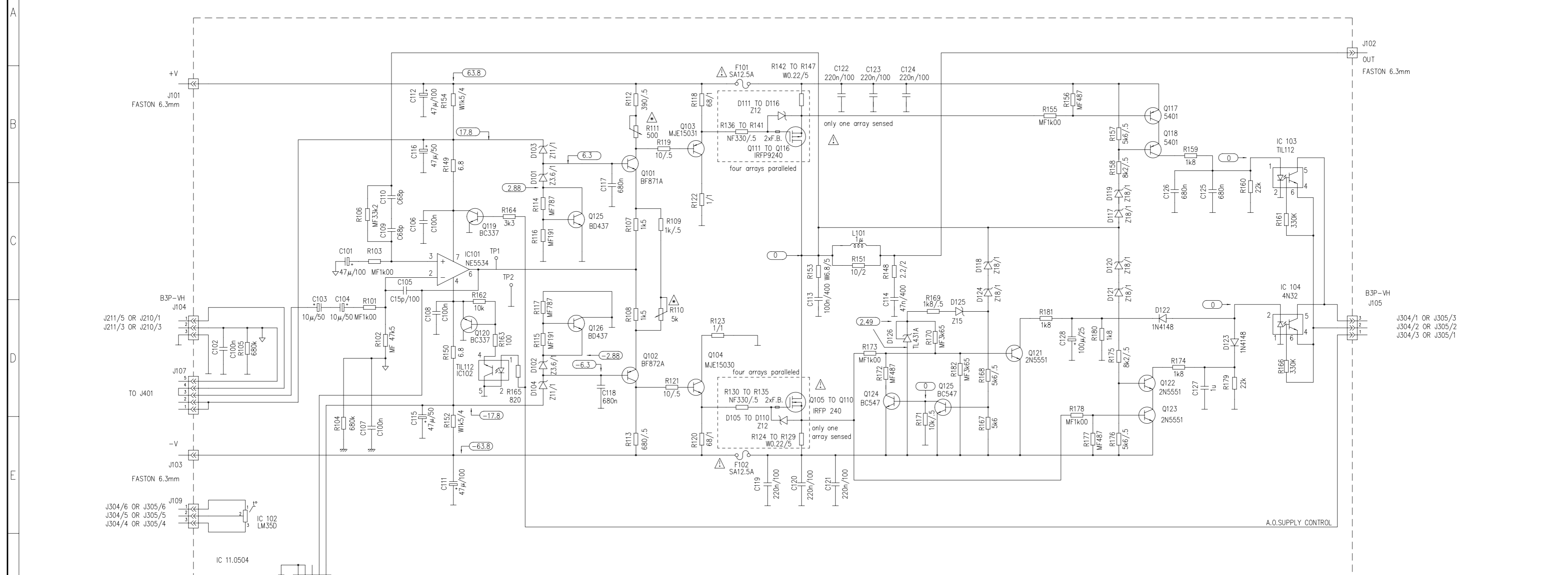

OLD VERSION

All capacitors 63 V, unless otherwise noted.
Resistors in Ohms. Capacitors in Farads. Inductors in Henries.
All resistors 1/4 W, unless otherwise noted.
See parts list for more information about components.
Part list specifies tolerance and power of the components.

Special schematic abbreviations:
MF metal film resistor
W wounded wire resistor
NF non inflammable resistor
T tantal capacitor
C ceramic capacitor
Z zener diode

- ▲ Factory adjusted.
- ▲ Critical component.
- kar TL 431A
- c b e 2N5551
- e b c BC337
- e c b BD437
- e c b BF871A
- b c e MJE15031
- G D S IRFP 9240
- IRFP 240
- TL112 4N32
- NE5534
- 321 LM350

TITLE: POWER CIRCUIT AND SHORT CIRCUIT PROTECTION SCHEMATIC DIAGRAM		MODEL: PAM 600 Switching Mosfet Power Amplifier		 LABORATORIO DE ELECTRO-ACUSTICA BARCELONA ESPAÑA
DRAWN: J.QUERALT		DATE: 071093		
CHECKED:		DATE:		DRW. NO. 10.0238
		REPLACES: 2 OF 6		REV.
		REPLACED BY:		

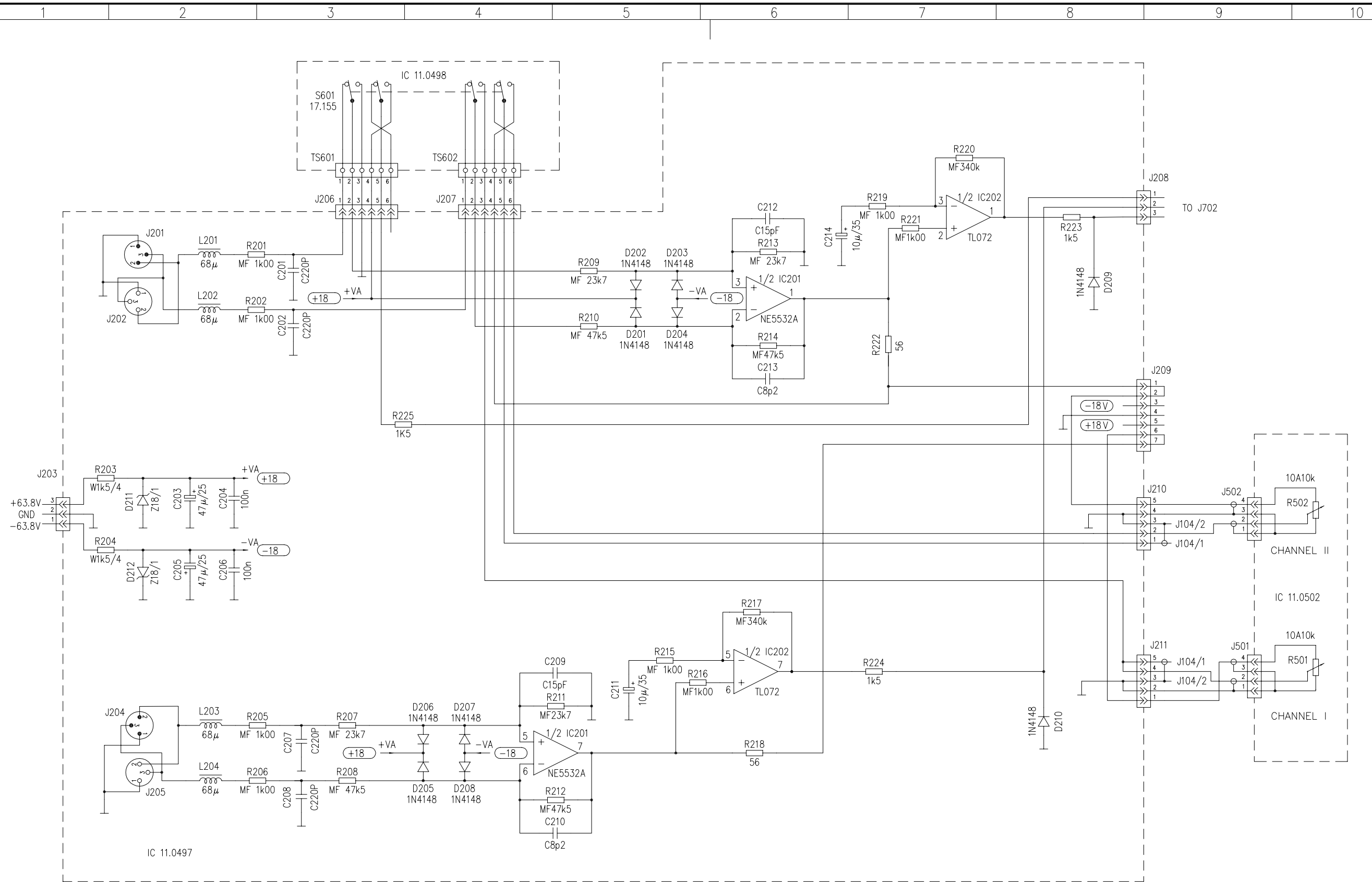

All capacitors 63 V, unless otherwise noted.
 Resistors in Ohms. Capacitors in Farads. Inductors in Henries.
 All resistors 1/4 W, unless otherwise noted.
 See parts list for more information about components.
 Part list specifies tolerance and power of the components.

Special schematic abbreviations:
 MF metal film resistor
 W wounded wire resistor
 NF non inflammable resistor
 T tantal capacitor
 C ceramic capacitor
 Z zener diode

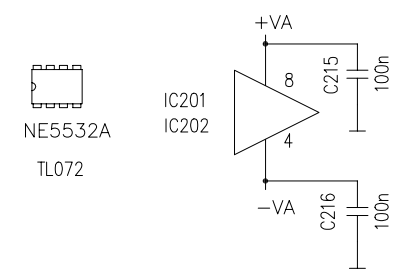

TITLE: INPUT CIRCUIT		MODEL: PAM600 Switching Power Mosfet Amplifier		 LABORATORIO DE ELECTRO-ACUSTICA BARCELONA ESPAÑA	
DRAWN: J.QUERALT		DATE: 300993			
CHECKED:		DATE:		REPLACES:	
		REPLACED BY:		DRW. NO. 10.0231	
				REV.	

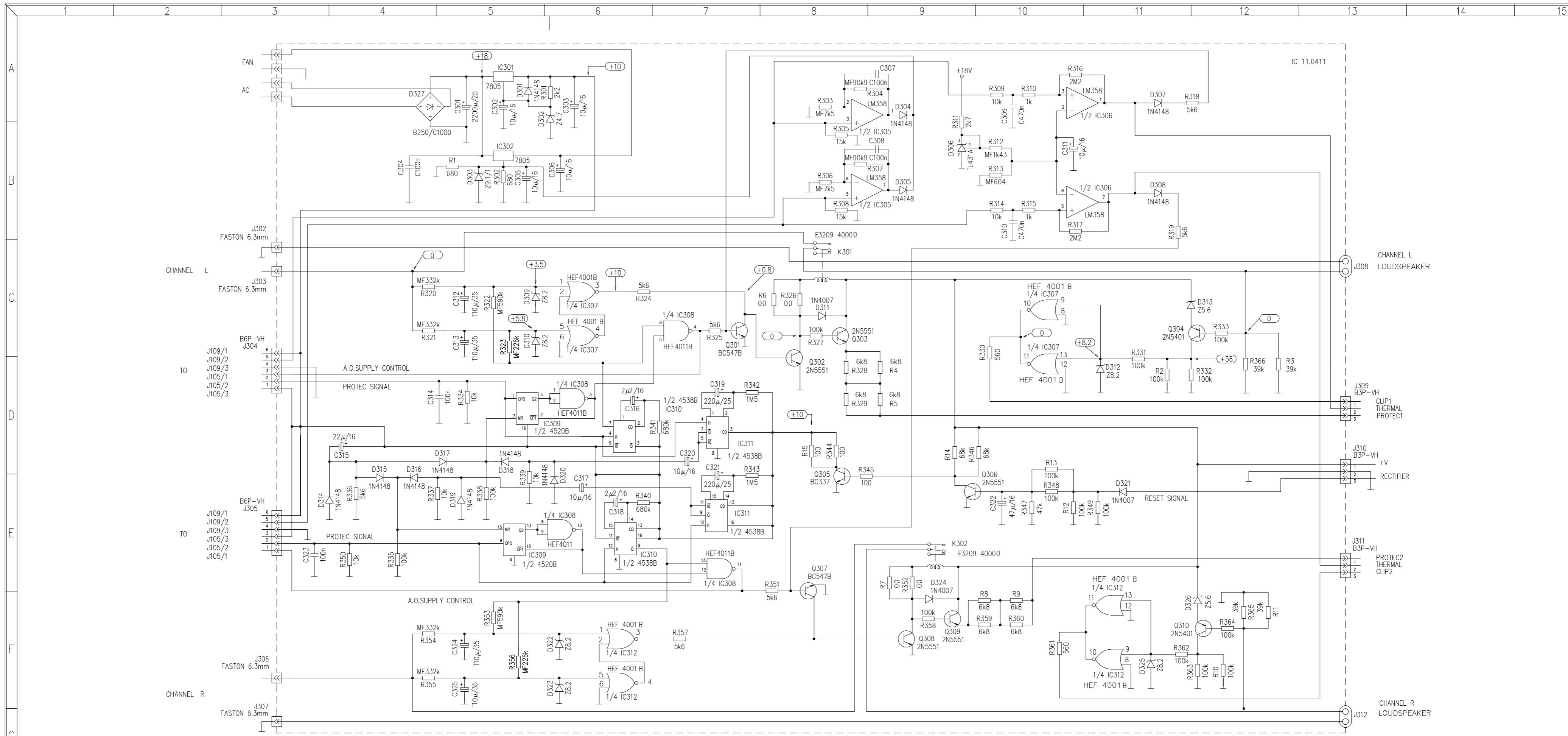

TITLE: PROTECTIONS CIRCUIT
 DRAWN: J.QUERALT
 CHECKED:

MODEL: PAM600/300
 Switching Power Mosfet Amplifier
 SHEET: 6 OF 6
 REPLACES:
 REPLACED BY:

ECLEROO
 LABORATORIO DE ELECTRO-ACUSTICA
 BARCELONA ESPAÑA
 DRW. NO. 10.0236
 REV.

All capacitors 63 V, unless otherwise noted.
 Resistors in Ohms, Capacitors in Farads, Inductors in Henries.
 All resistors 1/4 W, unless otherwise noted.
 See parts list for more information about components.
 Part list specifies tolerance and power of the components.

Special schematic abbreviations:
 MF metal film resistor 1%
 W wounded wire resistor
 T tantalum capacitor
 C ceramic capacitor
 Z zener diode

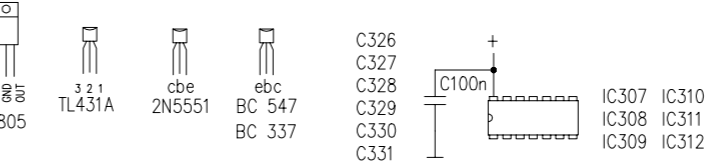

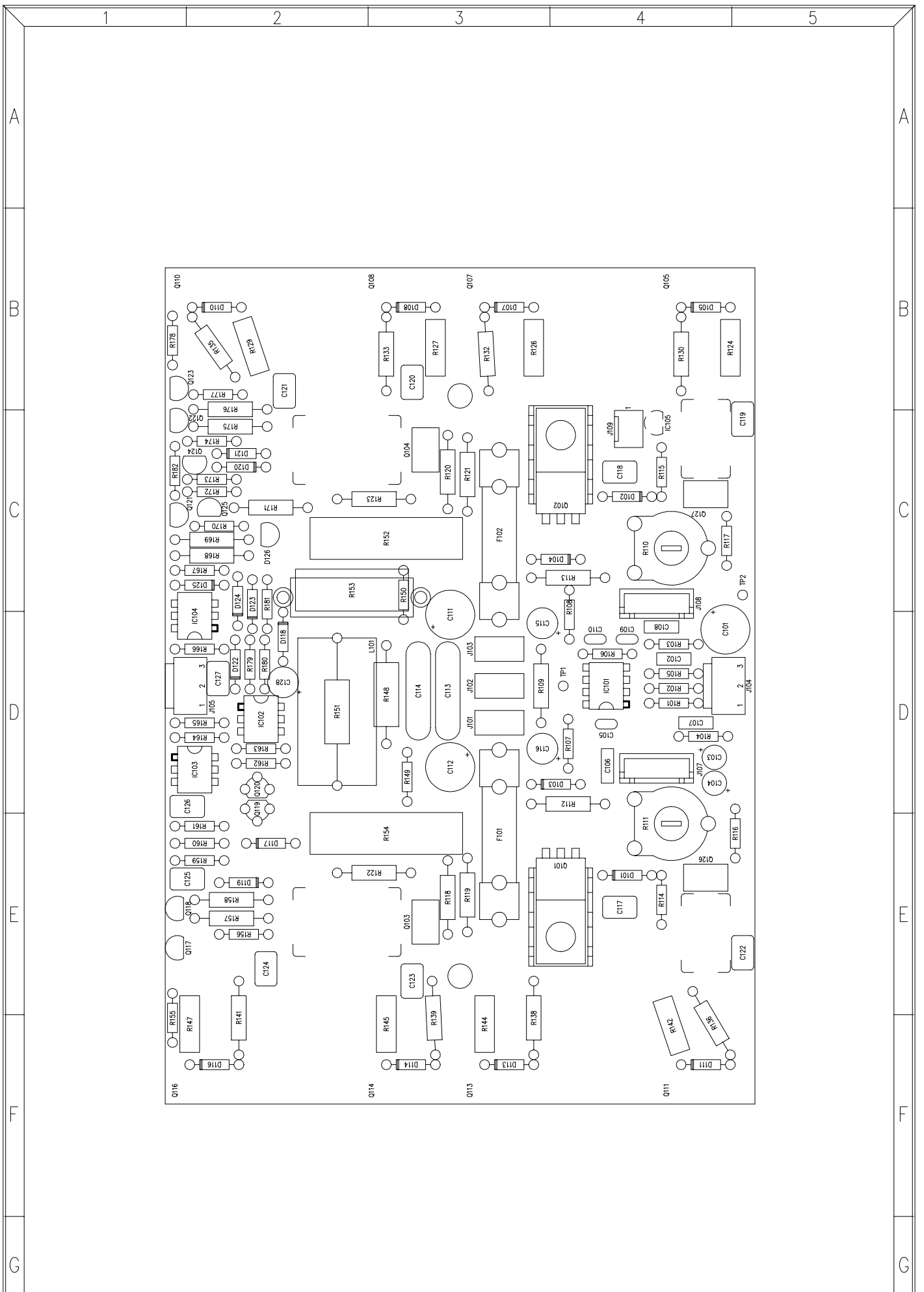

TITLE: POWER CIRCUIT AND SHORT CIRCUIT PROTECTION		MODEL: PAM600		 LABORATORIO DE ELECTRO-ACUSTICA BARCELONA ESPAÑA	
DRAWN: J.QUERALT		SHEET 1 OF 7			
DATE: 081193		REPLACES:		DRW. NO.	REV.
CHECKED:		REPLACED BY:		33.0009 R/	C

PARTS LIST:
MODEL:PAM600
DATE: 000621

POWER CIRCUIT AND SHORT CIRCUIT PROTECTION
DRW.N° 33.0009PL REV : A
SHEET 1 OF 3 REPLACED BY:

REFERENCE	VALUE
C101	47 μ /100
C102	C100n
C103	10 μ /50
C104	10 μ /50
C105	C15p
C106	C100n
C107	C100n
C108	C100n
C109	C68p
C110	C68p
C111	47 μ /100
C112	47 μ /100
C113	100n/400
C114	47n/400
C115	47 μ /50
C116	47 μ /50
C117	680n
C118	680n
C119	220n/100
C120	220n/100
C121	220n/100
C122	220n/100
C123	220n/100
C124	220n/100
C125	680n
C126	680n
C127	1 μ /63
C128	100 μ /25
CTO 11.0504	CTO.FRA.CU.
D101	Z3.6/1
D102	Z3.6/1
D103	Z11/1
D104	Z11/1
D105	Z12
D107	Z12
D108	Z12
D110	Z12
D111	Z12
D113	Z12
D114	Z12
D116	Z12
D117	Z18/1
D118	Z18/1
D119	Z18/1
D120	Z18/1
D121	Z18/1
D122	1N4148
D123	1N4148
D124	Z18/1
D125	Z15
D126	TL431
F101	TI-12.5
F102	TI-12.5
IC101	5534N
IC102	4N35
IC103	4N35
IC104	4N32
IC105	LM35D

PARTS LIST:
MODEL:PAM600
DATE: 000621

POWER CIRCUIT AND SHORT CIRCUIT PROTECTION
DRW.N° 33.0009PL REV : A
SHEET 2 OF 3 REPLACED BY:

REFERENCE	VALUE
J101	FASTON 6.3mm
J102	FASTON 6.3mm
J103	FASTON 6.3mm
J104	B3P-VH
J105	PROTEC
J107	B5B-XH
J108	B5B-XH
J109	2600-3TS
Q101	BF871
Q102	BF872
Q103	MJE15031
Q104	MJE15030
Q105	IRFP240
Q107	IRFP240
Q108	IRFP240
Q110	IRFP240
Q111	IRFP9240
Q113	IRFP9240
Q114	IRFP9240
Q116	IRFP9240
Q117	2N5401
Q118	2N5401
Q119	BC337
Q120	BC337
Q121	2N5551
Q122	2N5551
Q123	2N5551
Q124	BC547B
Q125	BC547B
Q126	BD437
Q127	BD437
R101	MF1k00
R102	MF47k5
R103	MF1k00
R104	680k
R105	680k
R106	MF33k2
R107	1k5
R108	1k5
R109	1k/.5
R110	5k
R111	500O
R112	NF390O/.5
R113	NF680O/.5
R114	MF787O
R115	MF191O
R116	MF191O
R117	MF787O
R118	NF68O/1
R119	10O/.5
R120	NF68O/1
R121	10O/.5
R122	1O/.5
R123	1O/.5
R124	W.22O/5
R126	W.22O/5
R127	W.22O/5
R129	W.22O/5

PARTS LIST:
MODEL:PAM600
DATE: 000621

POWER CIRCUIT AND SHORT CIRCUIT PROTECTION
DRW.N° 33.0009PL REV : A
SHEET 3 OF 3 REPLACED BY:

REFERENCE	VALUE
R130	NF330O/.5
R132	NF330O/.5
R133	NF330O/.5
R135	NF330O/.5
R136	NF330O/.5
R138	NF330O/.5
R139	NF330O/.5
R141	NF330O/.5
R142	W.22O/5
R144	W.22O/5
R145	W.22O/5
R147	W.22O/5
R148	NF2.2O/2
R149	6.8O
R150	6.8O
R151	10O/2
R152	W1k5/4
R153	W6.8O/5
R154	W1k5/4
R155	MF1k00
R156	MF487O
R157	5k6/.5
R158	8k2/.5
R159	1k8
R160	22k
R161	330k
R162	10k
R163	100O
R164	3k3
R165	820O
R166	330k
R167	5k6
R168	5k6/.5
R169	1k8/.5
R170	MF3k65
R171	10k/.5
R172	MF487O
R173	MF1k00
R174	1k8
R175	8k2/.5
R176	5k6/.5
R177	MF487
R178	MF1k00
R179	22k
R180	1k8
R181	1k8
R182	MF3k65

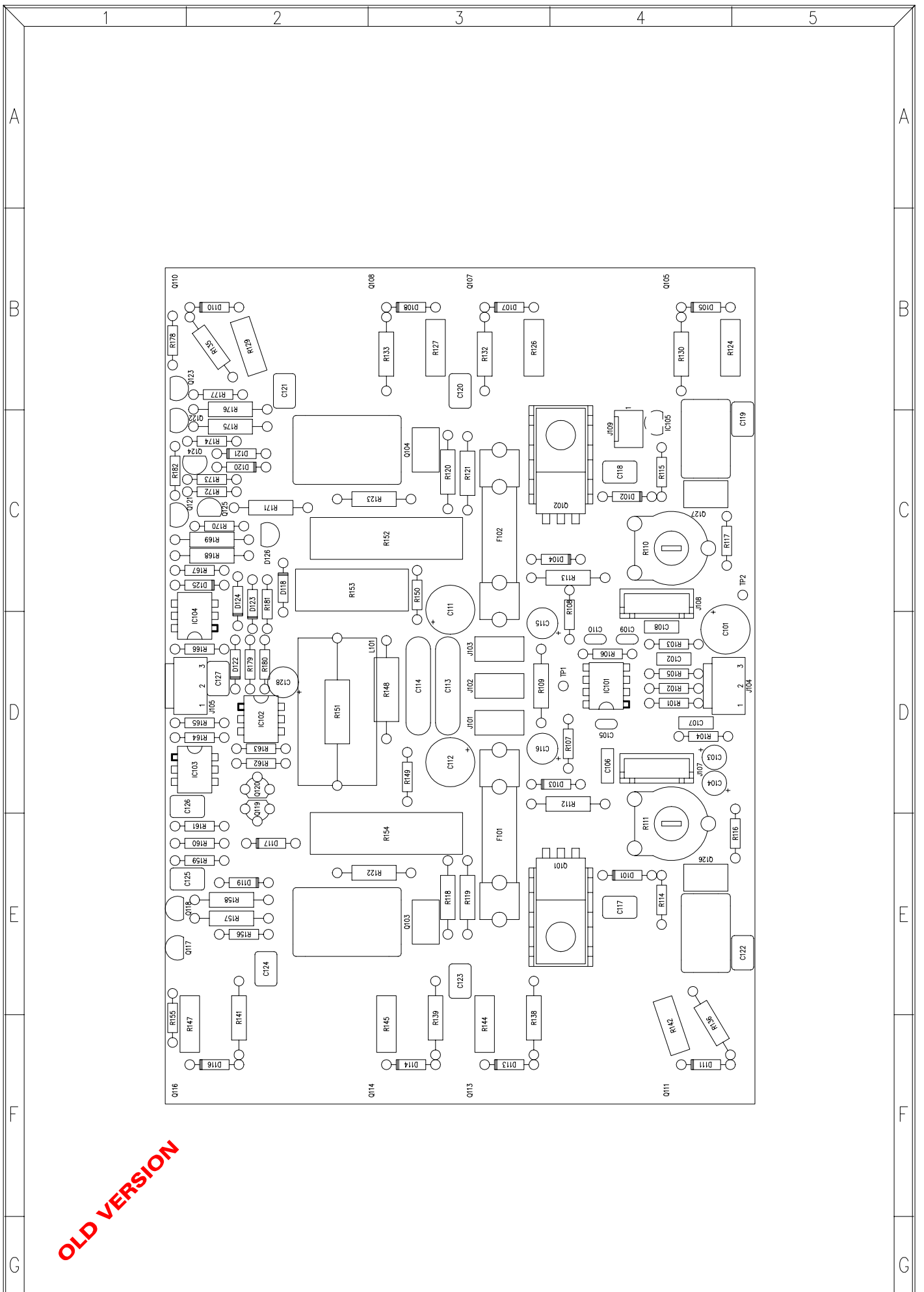

OLD VERSION

TITLE: POWER CIRCUIT AND SHORT CIRCUIT PROTECTION		MODEL: PAM600		 LABORATORIO DE ELECTRO-ACUSTICA BARCELONA ESPAÑA	
DRAWN: J.QUERALT		SHEET 1 OF 7			
DATE: 081193		REPLACES:		DRW. NO.	REV.
CHECKED:		REPLACED BY:		33.0009 R/	A

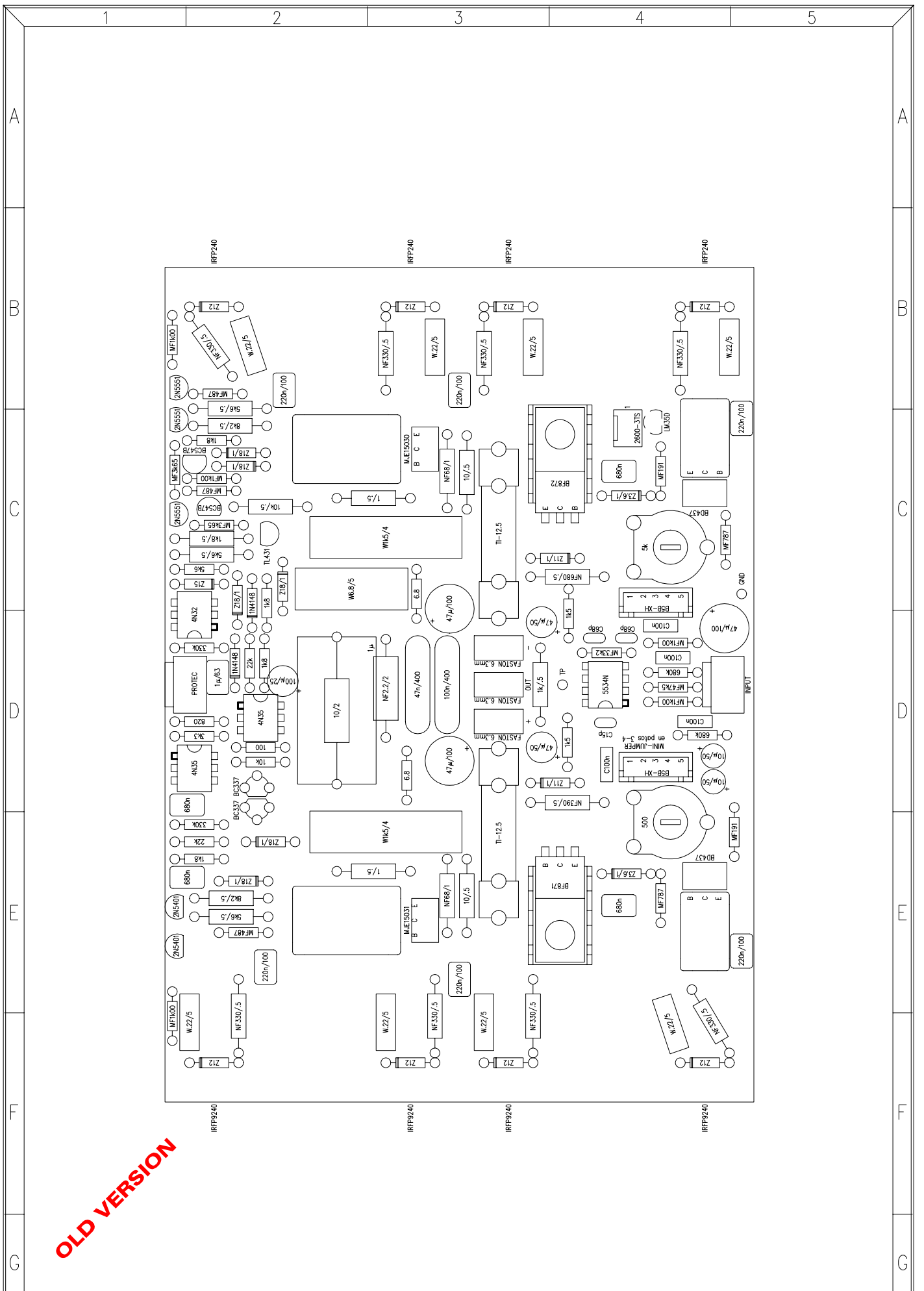

OLD VERSION

TITLE: POWER CIRCUIT AND SHORT CIRCUIT PROTECTION		MODEL: PAM600		 LABORATORIO DE ELECTRO-ACUSTICA BARCELONA ESPAÑA	
DRAWN: J.QUERALT		SHEET 1 OF 7			
DATE: 081193		REPLACES:		DRW. NO. 33.0009 v/	
CHECKED:		REPLACED BY:		REV. A	

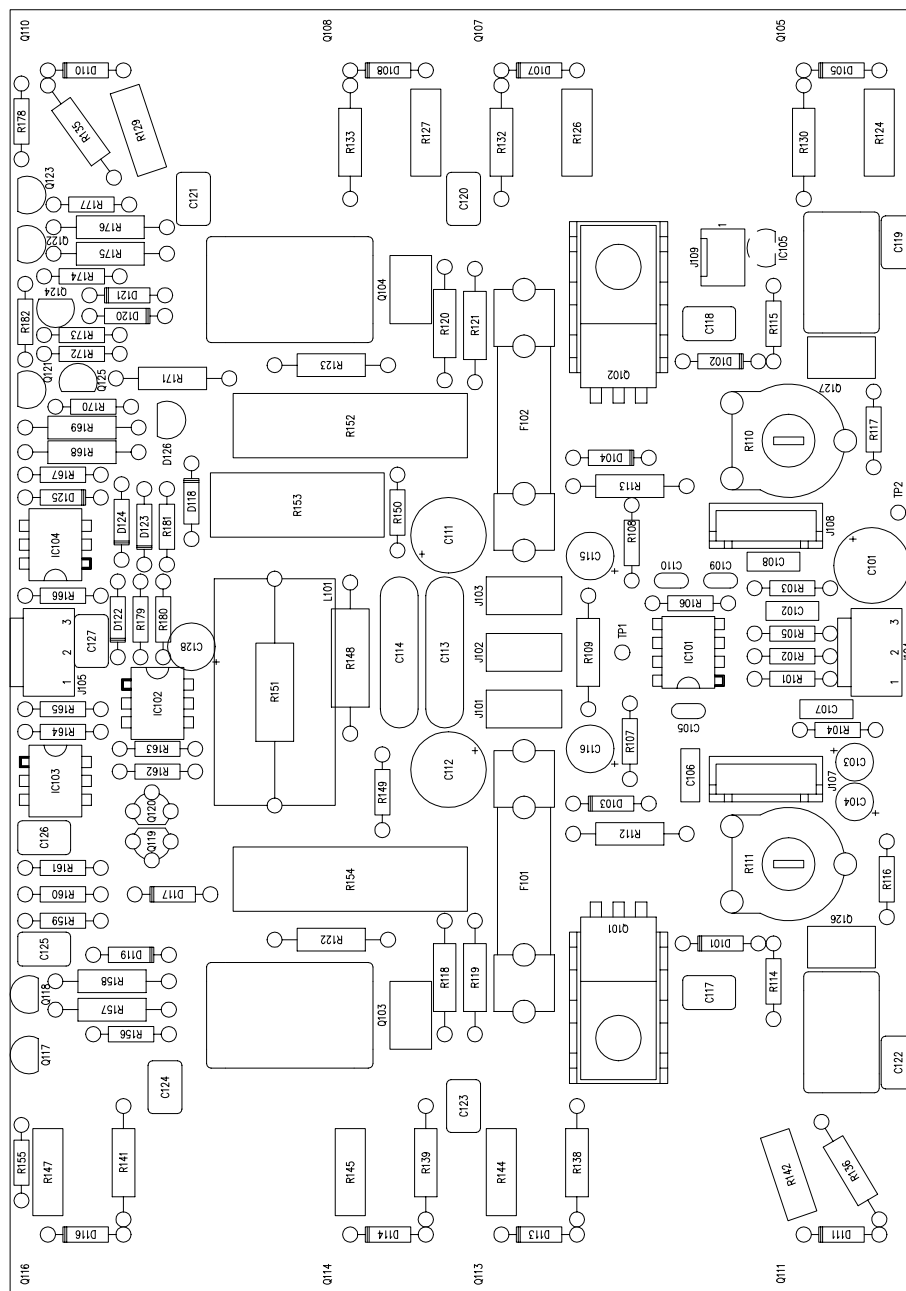

OLD VERSION

TITLE: POWER CIRCUIT AND SHORT CIRCUIT PROTECTION		MODEL: PAM600		 LABORATORIO DE ELECTRO-ACUSTICA BARCELONA ESPAÑA	
DRAWN: J.QUERALT		SHEET 1 OF 7			
DATE: 081193		REPLACES:		DRW. NO.	REV.
CHECKED:		REPLACED BY:		33.0009 R/	

PARTS LIST:
MODEL:PAM600
DATE: 081193

POWER CIRCUIT AND SHORT CIRCUIT PROTECTION
DRW.N° 33.0009PL REV :
SHEET 1 OF 3 REPLACED BY:

REFERENCE	VALUE
C101	47μ/100
C102	C100n
C103	10μ/50
C104	10μ/50
C105	C15p
C106	C100n
C107	C100n
C108	C100n
C109	C68p
C110	C68p
C111	47μ/100
C112	47μ/100
C113	100n/400
C114	47n/400
C115	47μ/50
C116	47μ/50
C117	680n
C118	680n
C119	220n/100
C120	220n/100
C121	220n/100
C122	220n/100
C123	220n/100
C124	220n/100
C125	680n
C126	680n
C127	1μ/63
C128	100μ/25
CTO 11.0504	CTO.FRA.CU.
D101	Z3.6/1
D102	Z3.6/1
D103	Z11/1
D104	Z11/1
D105	Z12
D107	Z12
D108	Z12
D110	Z12
D111	Z12
D113	Z12
D114	Z12
D116	Z12
D117	Z18/1
D118	Z18/1
D119	Z18/1
D120	Z18/1
D121	Z18/1
D122	1N4148
D123	1N4148
D124	Z18/1
D125	Z15
D126	TL431
F101	TI-12.5
F102	TI-12.5
IC101	5534N
IC102	TIL112
IC103	TIL112
IC104	4N32
IC105	LM35D

OLD VERSION

PARTS LIST:
MODEL:PAM600
DATE: 081193

POWER CIRCUIT AND SHORT CIRCUIT PROTECTION
DRW.N° 33.0009PL REV :
SHEET 2 OF 3 REPLACED BY:

REFERENCE	VALUE
J101	FASTON 6.3mm
J102	FASTON 6.3mm
J103	FASTON 6.3mm
J104	B3P-VH
J105	PROTEC
J107	B5B-XH
J108	B5B-XH
J109	2600-3TS
Q101	BF871
Q102	BF872
Q103	MJE15031
Q104	MJE15030
Q105	IRFP240
Q107	IRFP240
Q108	IRFP240
Q110	IRFP240
Q111	IRFP9240
Q113	IRFP9240
Q114	IRFP9240
Q116	IRFP9240
Q117	2N5401
Q118	2N5401
Q119	BC337
Q120	BC337
Q121	2N5551
Q122	2N5551
Q123	2N5551
Q124	BC547B
Q125	BC547B
Q126	BD437
Q127	BD437
R101	MF1k00
R102	MF47k5
R103	MF1k00
R104	680k
R105	680k
R106	MF33k2
R107	1k5
R108	1k5
R109	1k/.5
R110	5k
R111	500O
R112	NF390O/.5
R113	NF680O/.5
R114	MF787O
R115	MF191O
R116	MF191O
R117	MF787O
R118	NF68O/1
R119	10O/.5
R120	NF68O/1
R121	10O/.5
R122	1O/.5
R123	1O/.5
R124	W.22O/5
R126	W.22O/5
R127	W.22O/5
R129	W.22O/5

OLD VERSION

PARTS LIST:
MODEL:PAM600
DATE: 081193

POWER CIRCUIT AND SHORT CIRCUIT PROTECTION
DRW.N° 33.0009PL REV :
SHEET 3 OF 3 REPLACED BY:

REFERENCE	VALUE
R130	NF330O/.5
R132	NF330O/.5
R133	NF330O/.5
R135	NF330O/.5
R136	NF330O/.5
R138	NF330O/.5
R139	NF330O/.5
R141	NF330O/.5
R142	W.22O/5
R144	W.22O/5
R145	W.22O/5
R147	W.22O/5
R148	NF2.2O/2
R149	6.8O
R150	6.8O
R151	10O/2
R152	W1k5/4
R153	W6.8O/5
R154	W1k5/4
R155	MF1k00
R156	MF487O
R157	5k6/.5
R158	8k2/.5
R159	1k8
R160	22k
R161	330k
R162	10k
R163	100O
R164	3k3
R165	820O
R166	330k
R167	5k6
R168	5k6/.5
R169	1k8/.5
R170	MF3k65
R171	10k/.5
R172	MF487O
R173	MF1k00
R174	1k8
R175	8k2/.5
R176	5k6/.5
R177	MF487
R178	MF1k00
R179	22k
R180	1k8
R181	1k8
R182	MF3k65

OLD VERSION

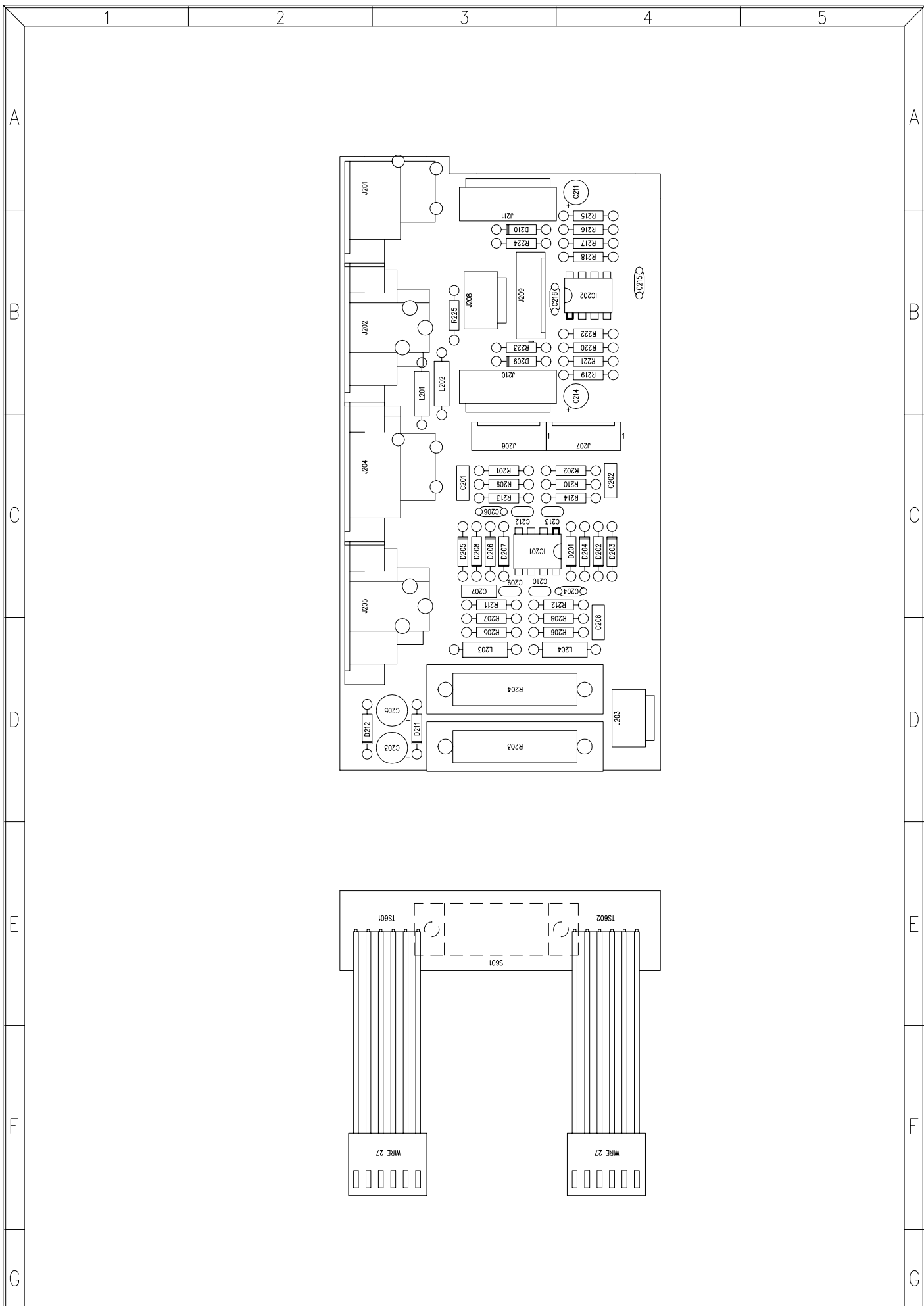

TITLE: INPUT CIRCUIT		MODEL: PAM600		 LABORATORIO DE ELECTRO-ACUSTICA BARCELONA ESPAÑA	
		SHEET 2 OF 7			
DRAWN: J.QUERALT	DATE: 081193	REPLACES:		DRW. NO. 33.0010 R/	REV.
CHECKED:	DATE:	REPLACED BY:			

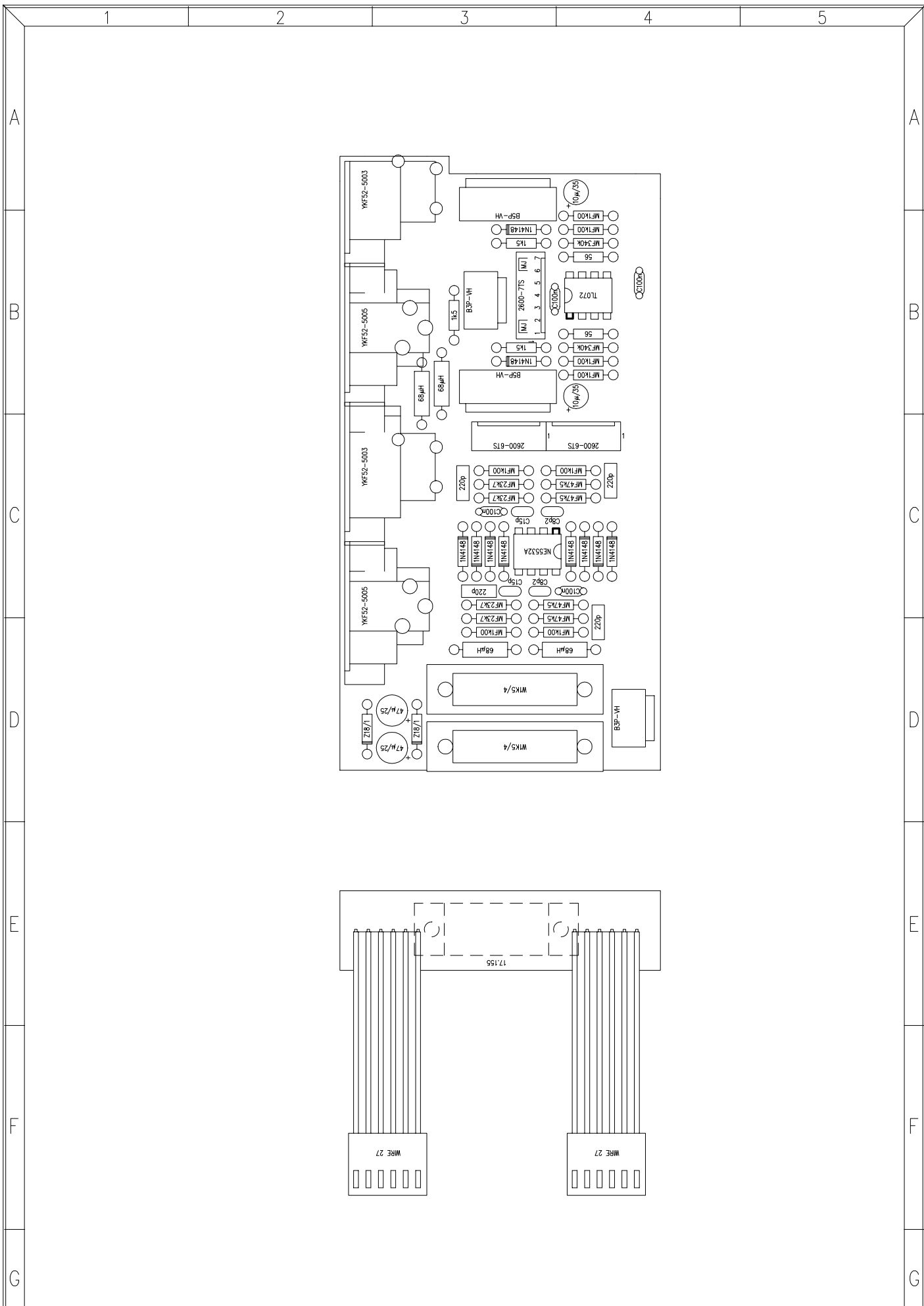

TITLE: INPUT CIRCUIT		MODEL: PAM600		 LABORATORIO DE ELECTRO-ACUSTICA BARCELONA ESPAÑA	
DRAWN: J.QUERALT		SHEET 2 OF 7			
DATE: 081193		REPLACES:		DRW. NO.	REV.
CHECKED:		REPLACED BY:		33.0010 v/	

PARTS LIST:
MODEL : PAM600
DATE: 081193

INPUT CIRCUIT
DRW. No 33.0010PL
SHEET 1 OF 2

REV:
REPLACED BY:

REFERENCE	VALUE
C201	220p
C202	220p
C203	47 μ /25
C204	C100n
C205	47 μ /25
C206	C100n
C207	220p
C208	220p
C209	C15p
C210	C8p2
C211	10 μ /35
C212	C15p
C213	C8p2
C214	10 μ /35
C215	C100n
C216	C100n
CABLE27	CABLE27
CABLE27	CABLE27
CTO 11.0497-8	CTO.FRA.CU
D201	1N4148
D202	1N4148
D203	1N4148
D204	1N4148
D205	1N4148
D206	1N4148
D207	1N4148
D208	1N4148
D209	1N4148
D210	1N4148
D211	Z18/1
D212	Z18/1
IC201	NE5532A
IC202	TL072
J201	YKF52-5003
J202	YKF52-5005
J203	B3P-VH
J204	YKF52-5003
J205	YKF52-5005
J206	2600-6TS
J207	2600-6TS
J208	B3P-VH
J209	2600-7TS
J210	B5P-VH
J211	B5P-VH
L201	68 μ H
L202	68 μ H
L203	68 μ H
L204	68 μ H
R201	MF1k00
R202	MF1k00
R203	W1k5/4
R204	W1k5/4
R205	MF1k00
R206	MF1k00
R207	MF23k7
R208	MF47k5

PARTS LIST:
MODEL : PAM600
DATE: 081193

INPUT CIRCUIT
DRW. No 33.0010PL
SHEET 1 OF 2

REV:
REPLACED BY:

REFERENCE	VALUE
R209	MF23k7
R210	MF47k5
R211	MF23k7
R212	MF47k5
R213	MF23k7
R214	MF47k5
R215	MF1k00
R216	MF1k00
R217	MF340k
R218	56
R219	MF1k00
R220	MF340k
R221	MF1k00
R222	56
R223	1k5
R224	1k5
R225	1k5
S601	17.155

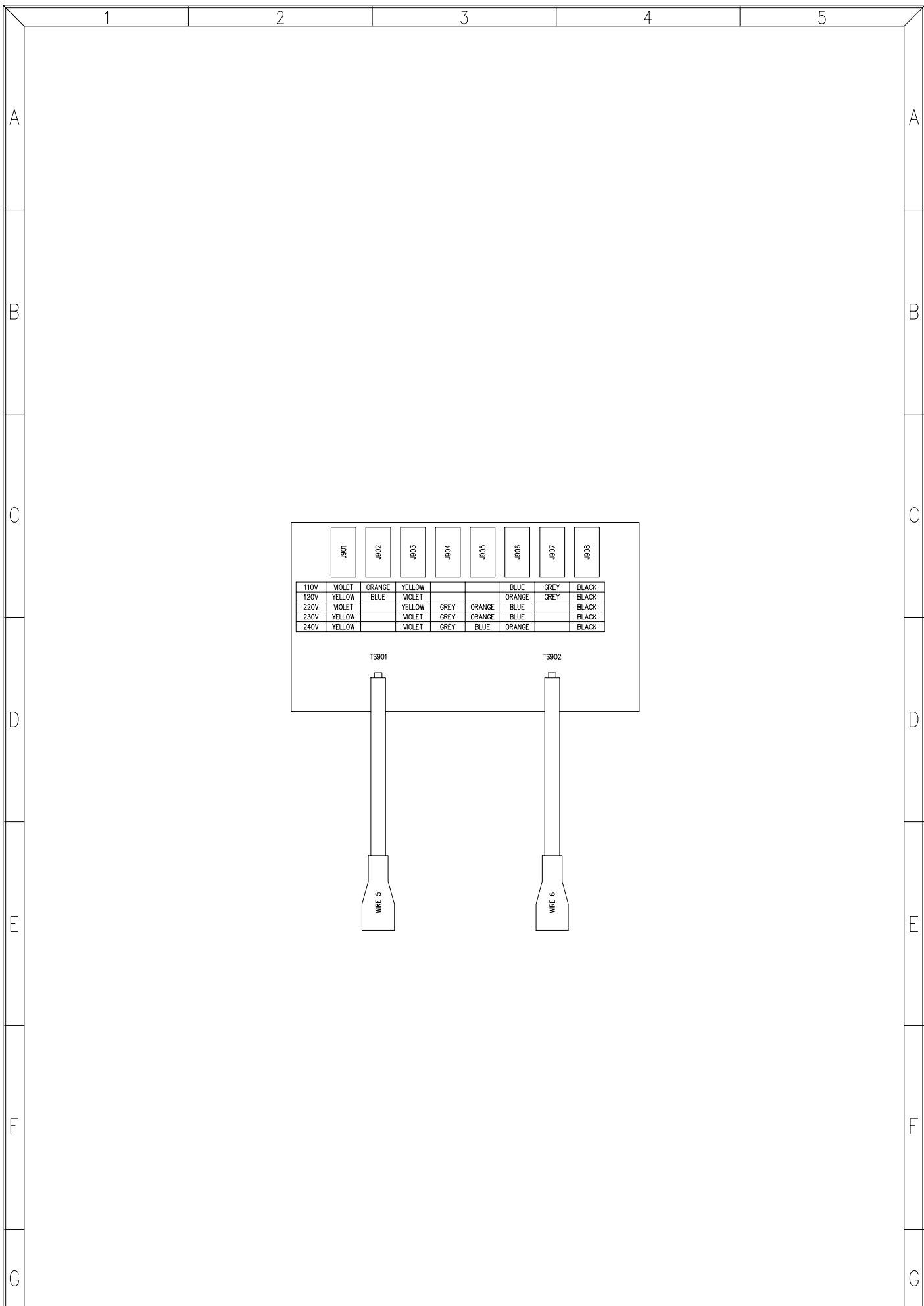

	J001	J002	J003	J004	J005	J006	J007	J008
110V	VIOLET	ORANGE	YELLOW			BLUE	GREY	BLACK
120V	YELLOW	BLUE	VIOLET			ORANGE	GREY	BLACK
220V	VIOLET		YELLOW	GREY	ORANGE	BLUE		BLACK
230V	YELLOW		VIOLET	GREY	ORANGE	BLUE		BLACK
240V	YELLOW		VIOLET	GREY	BLUE	ORANGE		BLACK

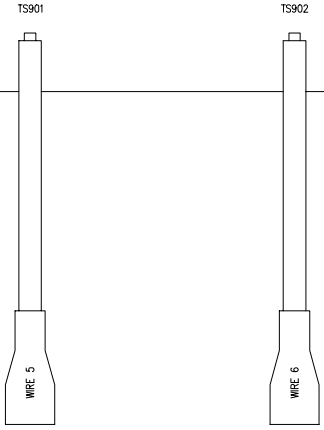

TITLE: POWER CIRCUIT		MODEL: PAM600/300		 LABORATORIO DE ELECTRO-ACUSTICA BARCELONA ESPAÑA	
		SHEET 6 OF 7			
DRAWN: J.QUERALT	DATE: 081193	REPLACES:		DRW. NO.	REV.
CHECKED:	DATE:	REPLACED BY:		33.0011 R/	

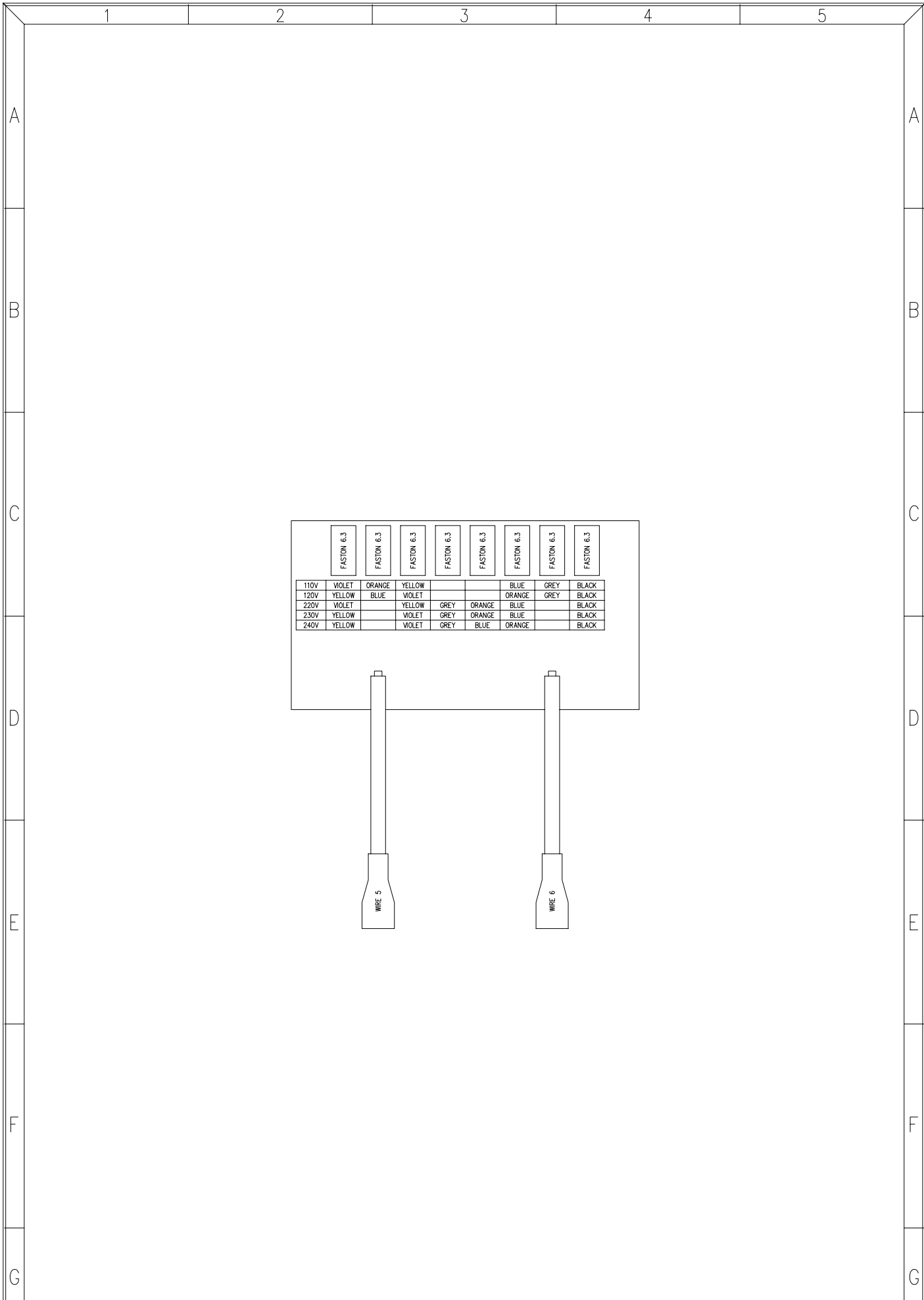

TITLE: POWER CIRCUIT		MODEL: PAM600/300		 LABORATORIO DE ELECTRO-ACUSTICA BARCELONA ESPAÑA	
		SHEET 6 OF 7			
DRAWN: J.QUERALT	DATE: 081193	REPLACES:		DRW. NO. 33.0011 v/	REV.
CHECKED:	DATE:	REPLACED BY:			

PARTS LIST:
MODEL : PAM600/300
DATE: 081193

POWER CIRCUIT
DRW. No 33.0011PL
SHEET 1 OF 1

REV:
REPLACED BY:

REFERENCE	VALUE
WIRE 5	WIRE 5
WIRE 6	WIRE 6
CTO 11.0500	CTO.FRA.CU.
J901	FASTON 6.3
J902	FASTON 6.3
J903	FASTON 6.3
J904	FASTON 6.3
J905	FASTON 6.3
J906	FASTON 6.3
J907	FASTON 6.3
J908	FASTON 6.3

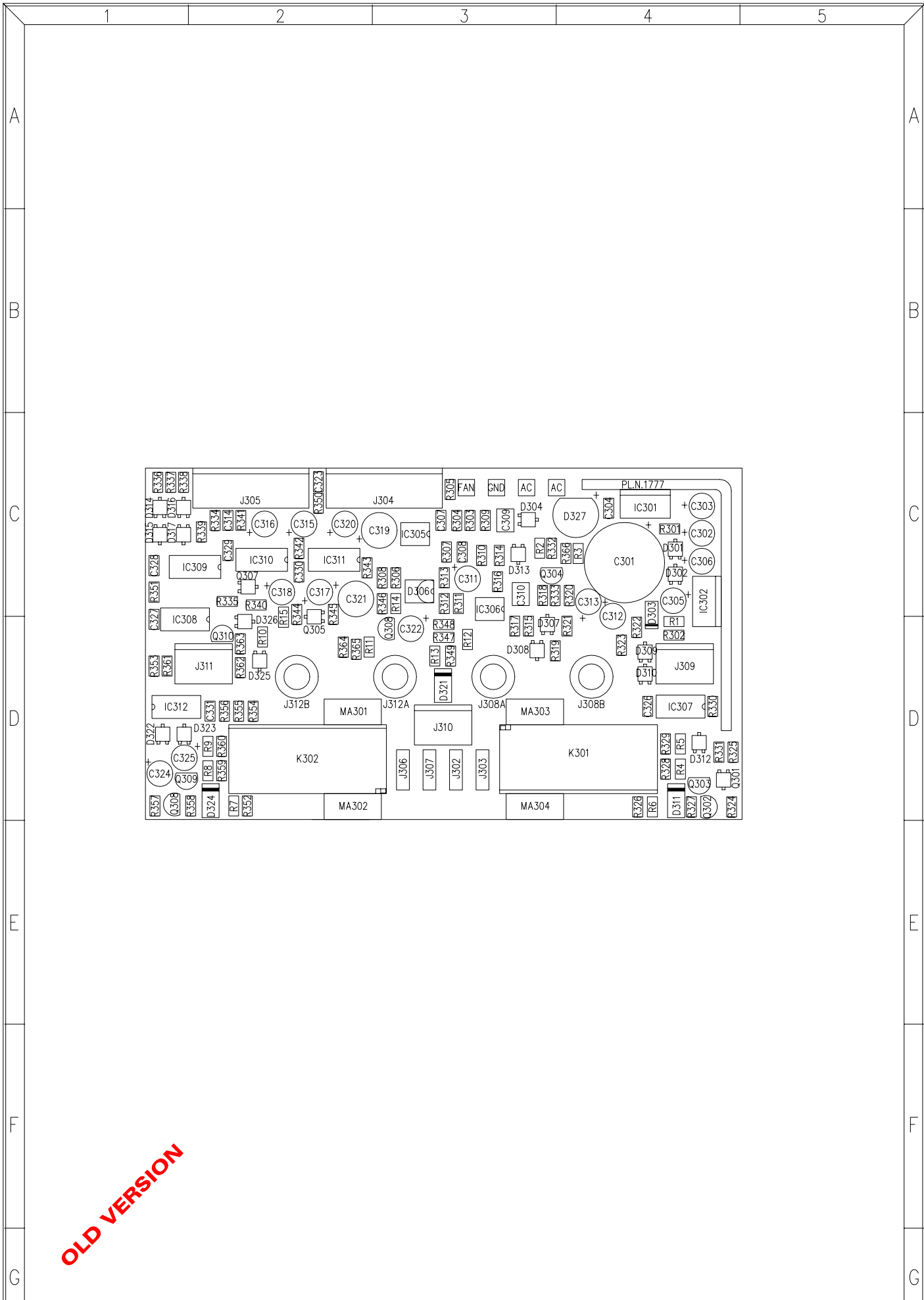

OLD VERSION

TITLE: PROTECTIONS CIRCUIT		MODEL: PAM600/300		 LABORATORIO DE ELECTRO-ACUSTICA BARCELONA ESPAÑA	
		SHEET 7 OF 7			
DRAWN: J.QUERALT	DATE: 241293	REPLACES:		DRW. NO.	REV.
CHECKED:	DATE:	REPLACED BY:		11.0411 R/	

PARTS LIST:
MODEL : PAM600/300
DATE: 241293

PROTECTIONS CIRCUIT
DRW. No 33.0013PL
SHEET 1 OF 4 REPLACES:

REV:
REPLACED BY:

REFERENCE	VALUE
AC	FAST.2.8
AC	FAST.2.8
C301	2200 μ /35
C302	10 μ /50
C303	10 μ /50
C304	100n
C305	10 μ /50
C306	10 μ /50
C307	100n
C308	100n
C309	470n
C310	470n
C311	10 μ /50
C312	10 μ /35
C313	10 μ /35
C314	100n
C315	22 μ /35
C316	2 μ 2/35
C317	10 μ /50
C318	2 μ 2/35
C319	220 μ /25
C320	10 μ /50
C321	220 μ /25
C322	47 μ /16
C323	100n
C324	10 μ /35
C325	10 μ /35
C326	100n
C327	100n
C328	100n
C329	100n
C330	100n
C331	100n
D301	BAS16
D302	Z4.7
D303	Z9.1/1
D304	BAV70
D306	TL431
D307	BAS16
D308	BAS16
D309	Z8.2
D310	Z8.2
D311	1N4007
D312	Z8.2
D313	Z5.6
D314	BAV99
D315	BAS16
D316	BAV99
D317	BAV99
D321	1N4007
D322	Z8.2
D323	Z8.2
D324	1N4007
D325	Z8.2
D326	Z5.6
D327	B250C1000

OLD VERSION

PARTS LIST:
MODEL : PAM600/300
DATE: 241293

PROTECTIONS CIRCUIT
DRW. No 33.0013PL
SHEET 2 OF 4 REPLACES:

REV:
REPLACED BY:

REFERENCE	VALUE
FAN	FAST.2.8
GND	FAST.2.8
IC301	7805
IC302	7805
IC305	LM358D
IC306	LM358D
IC307	HEF4001B
IC308	HEF4011B
IC309	HEF4520B
IC310	HEF4538B
IC311	HEF4538B
IC312	HEF4001B
INSULANT WASHER	R19
INSULANT WASHER	R19
J302	FAST.6.3
J303	FAST.6.3
J304	B6P-VH
J305	B6P-VH
J306	FAST.6.3
J307	FAST.6.3
J309	B3P-VH
J310	B3P-VH
J311	B3P-VH
K301	E 3209/4000Ω
K302	E 3209/4000Ω
MA301	MAGNET
MA302	MAGNET
MA303	MAGNET
MA304	MAGNET
NUT	M3
NUT	M3
PL.N.1777	RADIATOR
Q301	BC847B
Q302	2N5551
Q303	2N5551
Q304	2N5401
Q305	BC817
Q307	BC847B
Q308	2N5551
Q308	2N5551
Q309	2N5551
Q310	2N5401
R1	680
R10	100k
R11	39K
R12	100k
R13	100k
R14	68K
R15	100
R2	100k
R3	39K
R301	2K2
R302	680
R303	7K50
R304	90K9
R305	15K

OLD VERSION

PARTS LIST:
MODEL : PAM600/300
DATE: 241293

PROTECTIONS CIRCUIT
DRW. No 33.0013PL
SHEET 3 OF 4 REPLACES:

REV:
REPLACED BY:

REFERENCE	VALUE
R306	7K50
R307	90K9
R308	15K
R309	10K
R310	1K
R311	2K7
R312	1K43
R313	604
R314	10K
R315	1K
R316	2M2
R317	2M2
R318	5K6
R319	5K6
R320	332K
R321	332K
R322	590K
R323	226K
R324	5K6
R325	5K6
R326	0
R327	100k
R328	6K8
R329	6K8
R330	560
R331	100K
R332	100k
R333	100k
R334	10K
R335	100k
R336	5K6
R337	10K
R338	100k
R339	10K
R340	680K
R341	680K
R342	1M2
R343	1M2
R344	100
R345	100
R346	68K
R347	47K
R348	100k
R349	100k
R350	10K
R351	5K6
R352	0
R353	590K
R354	332K
R355	332K
R356	226K
R357	5K6
R358	100k
R359	6K8
R360	6K8
R361	560

OLD VERSION

PARTS LIST:
MODEL : PAM600/300
DATE: 241293

PROTECTIONS CIRCUIT
DRW. No 33.0013PL
SHEET 4 OF 4 REPLACES:

REV:
REPLACED BY:

REFERENCE	VALUE
R362	100k
R363	100k
R364	100k
R365	39K
R366	39K
R4	6K8
R5	6K8
R6	0
R7	0
R8	6K8
R9	6K8
SCREW	M3X8 DIN7985 NINE
SCREW	M3X8 DIN7985 NINE
WASHER	ADE M3
WASHER	ADE M3
PC 11.0411	PRINTED CIRCUIT

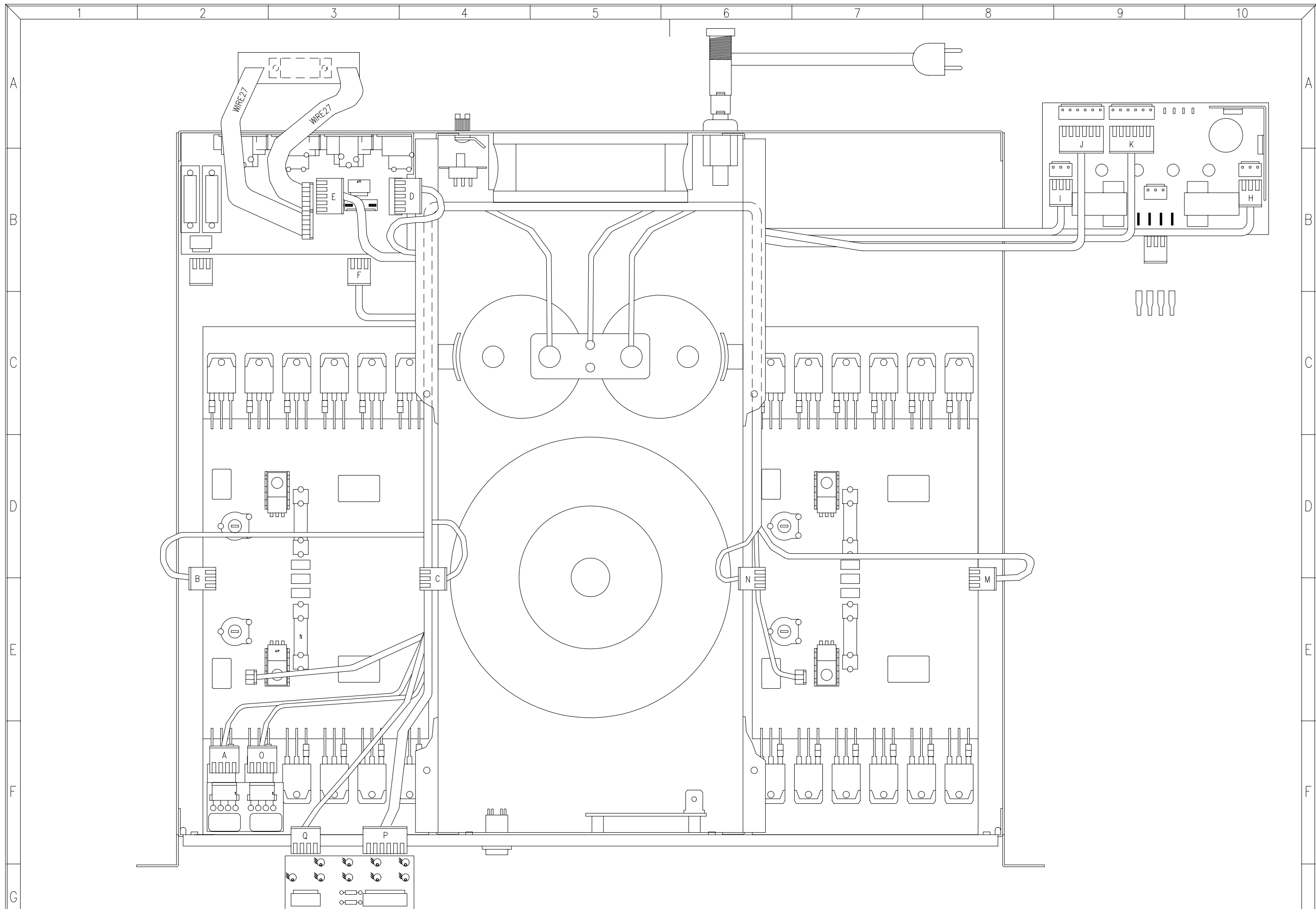

TITLE:
WIRING DIAGRAM (SIGNAL)

DRAWN: J.QUERALT
CHECKED:

DATE: 061293
DATE:

MODEL: PAM600/300

SHEET 1 OF 2

REPLACES:
REPLACED BY:

ECLER

LABORATORIO DE ELECTRO-ACUSTICA
BARCELONA ESPAÑA

DRW. NO. 31.0003
REV.

6 7 8 9 10

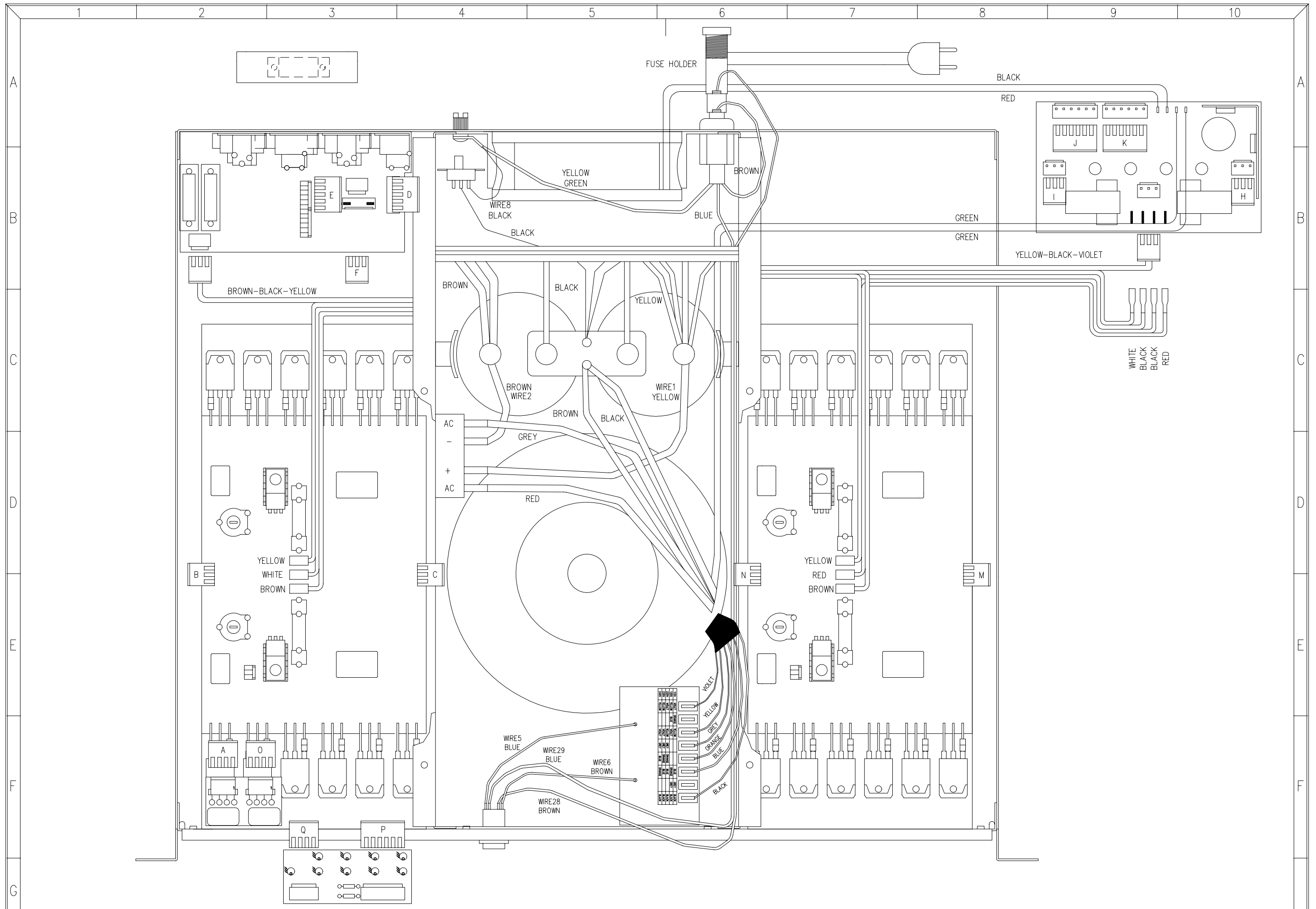

TITLE: WIRING DIAGRAM (POWER)		MODEL: PAM600/300		 LABORATORIO DE ELECTRO-ACUSTICA BARCELONA ESPAÑA	
DRAWN: J.QUERALT		SHEET 2 OF 2			
DATE: 061293	REPLACES:	DRW. NO. 31.0004	REV.		
CHECKED:	DATE:	REPLACED BY:			

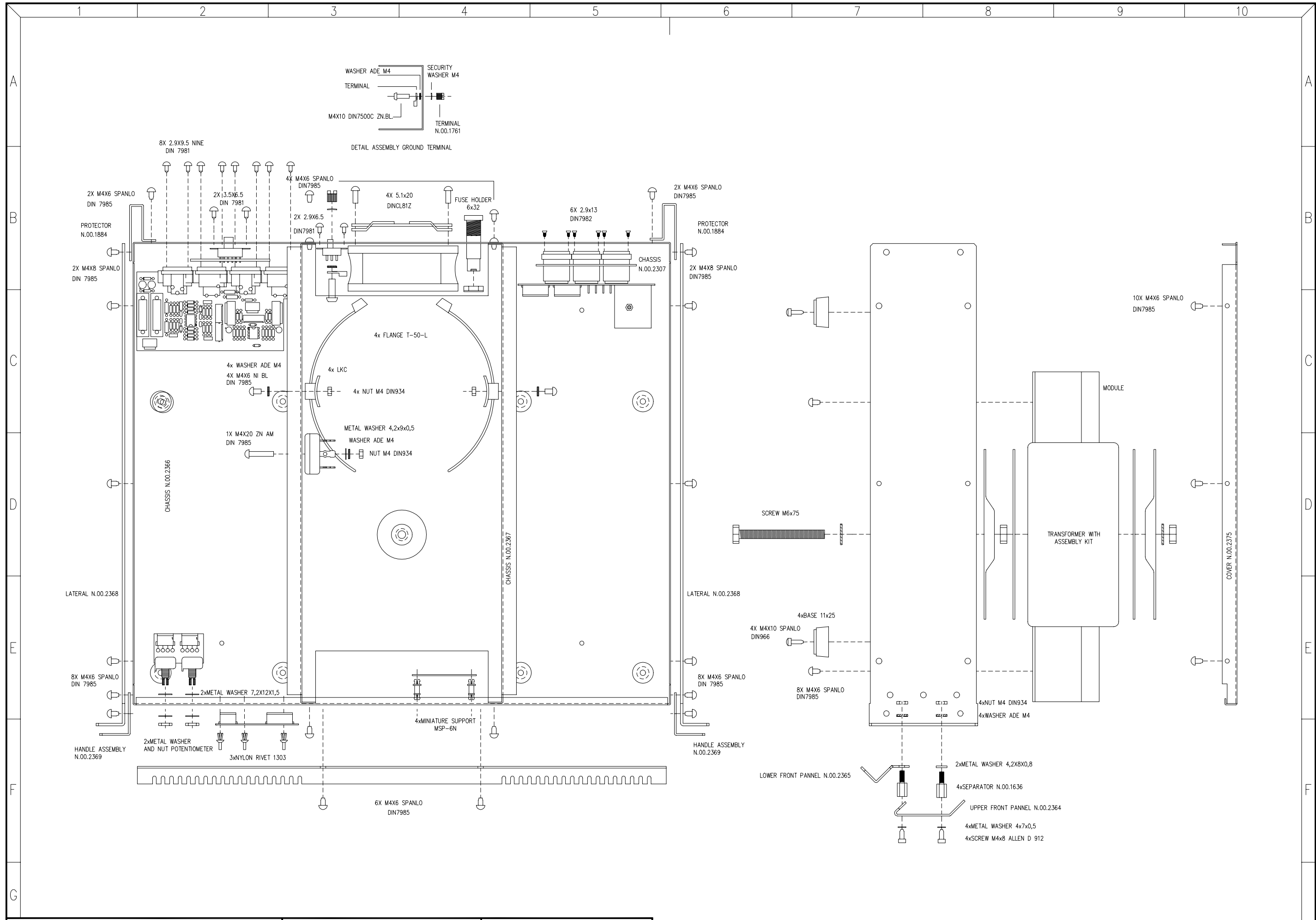

TITLE: MECHANICAL DIAGRAM		MODEL: PAM600/300		 LABORATORIO DE ELECTRO-ACUSTICA BARCELONA ESPAÑA	
DRAWN: J.QUERALT		SHEET 1 OF 1			
DATE: 180297	REPLACES:	DRW. NO. 30.0004	REV. C		
CHECKED:	DATE:	REPLACED BY:			

PARTS LIST: MECHANICAL DIAGRAM
MODEL:PAM600/300 DRW.N° 300004PL
DATE: 180297 SHEET 1 OF 1

REV: C
REPLACES:
REPLACED BY:

QUANTITY DESCRIPT

10 SCREW 2,9x6,5 DIN7981
2 SCREW 3,5x6,5 DIN 7981
34 SCREW M4x6 SPANLO DIN7985
5 SCREW M4x12 DIN7985
1 SCREW M4x20 DIN7985
4 SCREW M4x10 SPANLO DIN966
4 SCREW M4x8 TX SPIRALFORM
4 SCREW M4x6 DIN7985
10 METAL WASHER ADE M4
1 METAL WASHER 4,2x9x0,5
4 METAL WASHER 4x7x0,5
2 METAL WASHER 4,2x9x1,5
9 NUT M4 DIN934
2 METAL WASHER AND NUT POTENTIOMETER
1 RIVET NUT M4-PSM
1 GROUND TERMINAL N°00.1761
1 SECURITY WASHER M4
3 NYLON RIVET 1303
4 MINIATURE SUPPORT MSP-6N
4 SEPARATOR N°00.1636
4 BASE 11x25
1 FUSE HOLDER 6x32
1 COMMUTATOR N°17.120
4 SUPPORT LKC
4 FLANGE T-50L
1 TRANSFORMER REF.18Z160 (19Z130) WIT ASSEMBLY KIT
1 FAN REF.NMB3110NL-04W B50
1 CHASSIS WD.00.2367
1 CHASSIS WD.00.2366
1 HANDLE ASSEMBLY WD.00.2369
1 COVER WD.00.2375
1 UPPER FRONT PANEL WD.00.2364
1 LOWER FRONT PANEL WD.00.2365
1 FAN PROTECTOR 80x80mm
1 HANDLE ASSEMBLY N°00.1962
1 SCREW M4x10 DIN7500C ZNBL
1 CHASSIS WD.00.2307
6 SCREW 2.9x13 DIN7982

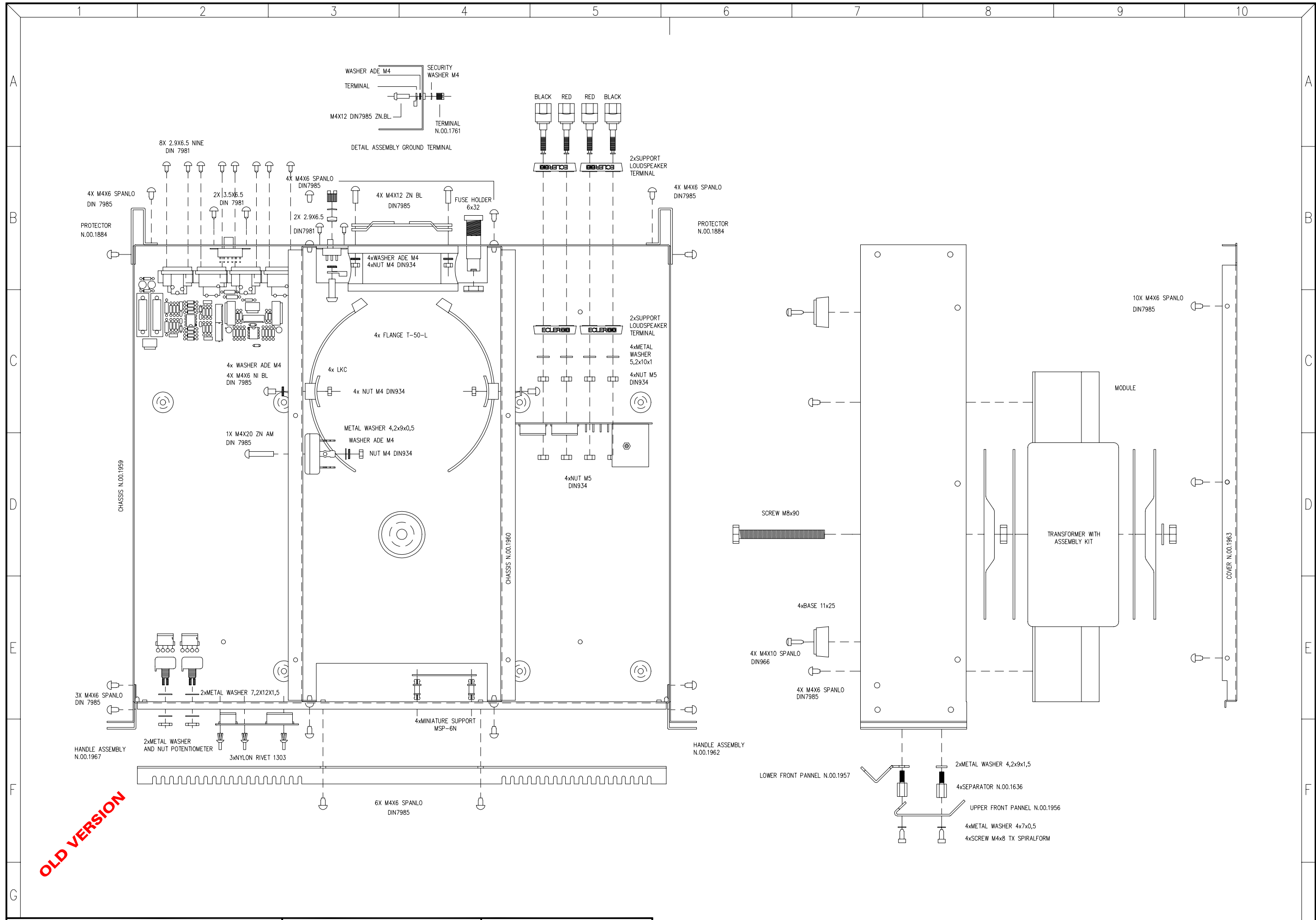

TITLE: MECHANICAL DIAGRAM		MODEL: PAM600/300		 LABORATORIO DE ELECTRO-ACUSTICA ESPAÑA	
DRAWN: J.QUERALT		DATE: 021293			
CHECKED:		DATE:		REPLACES:	
				REPLACED BY:	
				DRW. NO. 30.0004	
				REV.	

PARTS LIST:
MODEL:PAM600/300
DATE: 021293

MECHANICAL DIAGRAM
DRW.N° 300004PL
SHEET 1 OF 1

REV:
REPLACES:
REPLACED BY:

QUANTITY DESCRIPT

10 SCREW 2,9x6,5 DIN7981
2 SCREW 3,5x6,5 DIN 7981
34 SCREW M4x6 SPANLO DIN7985
5 SCREW M4x12 DIN7985
1 SCREW M4x20 DIN7985
4 SCREW M4x10 SPANLO DIN966
4 SCREW M4x8 TX SPIRALFORM
4 SCREW M4x6 DIN7985
10 METAL WASHER ADE M4
1 METAL WASHER 4,2x9x0,5
4 METAL WASHER 4x7x0,5
2 METAL WASHER 4,2x9x1,5
9 NUT M4 DIN934
8 NUT M5 DIN934
4 METAL WASHER 5,2x10x1
2 METAL WASHER AND NUT POTENTIOMETER
1 RIVET NUT M4-PSM
1 GROUND TERMINAL N°00.1761
1 SECURITY WASHER M4
3 NYLON RIVET 1303
4 MINIATURE SUPPORT MSP-6N
4 SEPARATOR N°00.1636
4 BASE 11x25
1 FUSE HOLDER 6x32
1 COMMUTATOR N°17.120
4 SUPPORT LKC
4 FLANGE T-50L
1 TRANSFORMER REF.18Z160 (19Z130) WIT ASSEMBLY KIT
1 FAN REF.NMB3110NL-04W B50
1 CHASSIS N°00.1960
1 CHASSIS N°00.1959
1 HANDLE ASSEMBLY N°00.1967
1 COVER N°00.1963
1 UPPER FRONT PANEL N°00.1956
1 LOWER FRONT PANEL N°00.1957
2 JOINED CONNECTOR LOUDSPEAKER
1 PROTECTOR FAN 80x80mm
1 HANDLE ASSEMBLY N°00.1962

OLD VERSION

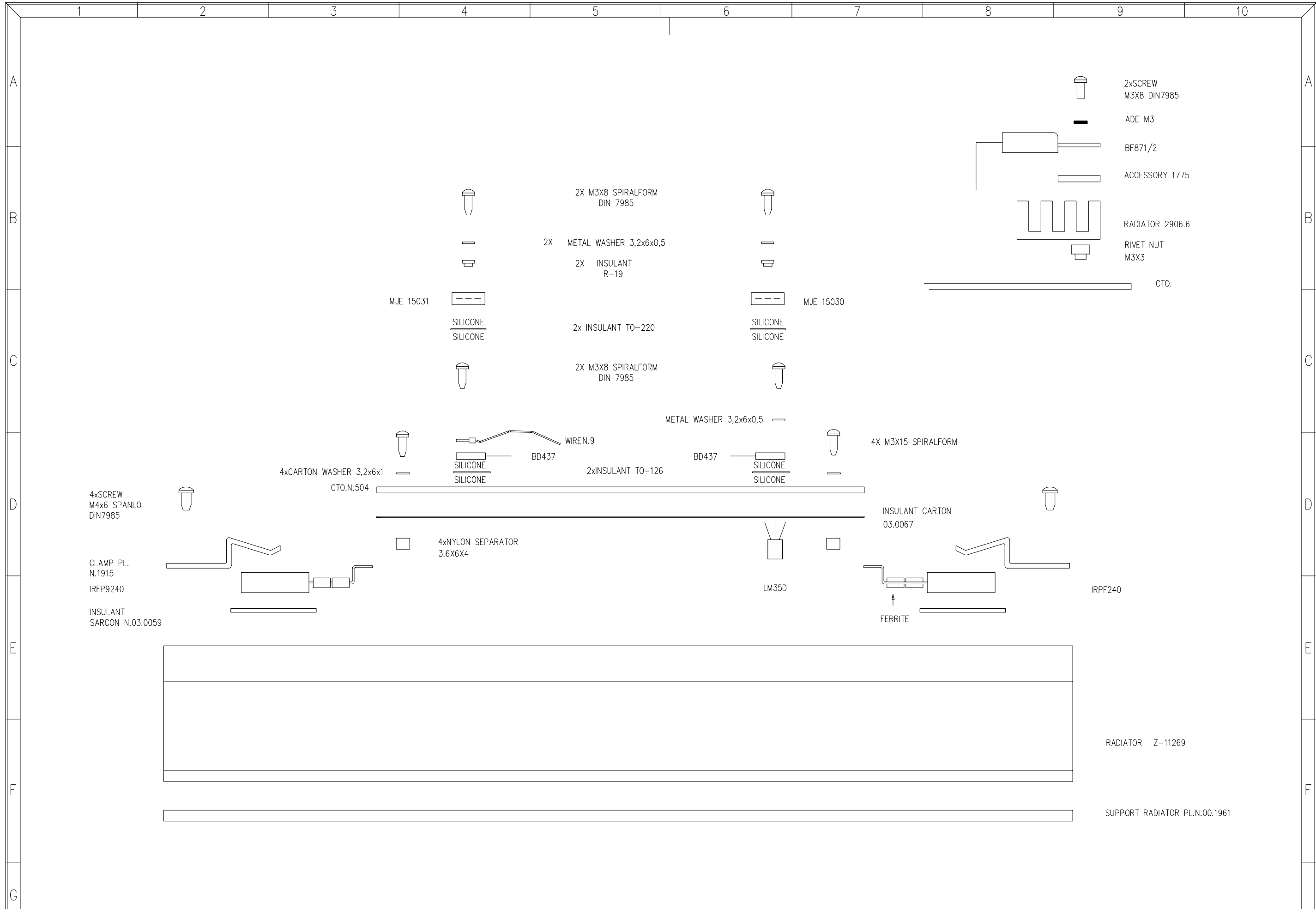

TITLE: ASSEMBLY MODULE		MODEL: PAM600/300		 LABORATORIO DE ELECTRO-ACUSTICA ESPAÑA	
DRAWN: J.QUERALT		DATE: 101293			
CHECKED:		DATE:		REPLACES:	
		REPLACED BY:		DRW. NO. 30.0005	
				REV.	

PARTS LIST:
MODEL : PAM600
DATE: 101293

ASSEMBLY MODULE
DRW. No 30.0005PL
SHEET 1 OF 1 REPLACES:

REV:
REPLACED BY:

QUANTITY VALUE

3 METAL WASHER 3.2X6X0.5
2 INSULANT. WASHER R19
2 MICA TO-220
2 MICA TO-126
1 WIRE N°9
4 SCREW M3X8 SPIRALFORM DIN7985
4 SCREW M3X15 SPIRALFORM DIN 7985
4 NYLON SEPARATOR 3.6X6.4
4 SCREW M4X6 SPANLO DIN7985
2 RIVET NUT M3X3
2 ACCESSORY PL.N°1775
2 SCREW M3X8 DIN7985
2 WASHER ADE M3
2 ACCESSORY PL. N°1915
4 CARTON WASHER 3.2X6X1
1 INSULANT CARTON PL.N°03.0067
8 INSULANT SARCON N.03.0059
1 RADIATOR Z-11269
2 RADIATOR N°2906.6
1 SUPPORT RADIATOR N.00.1961

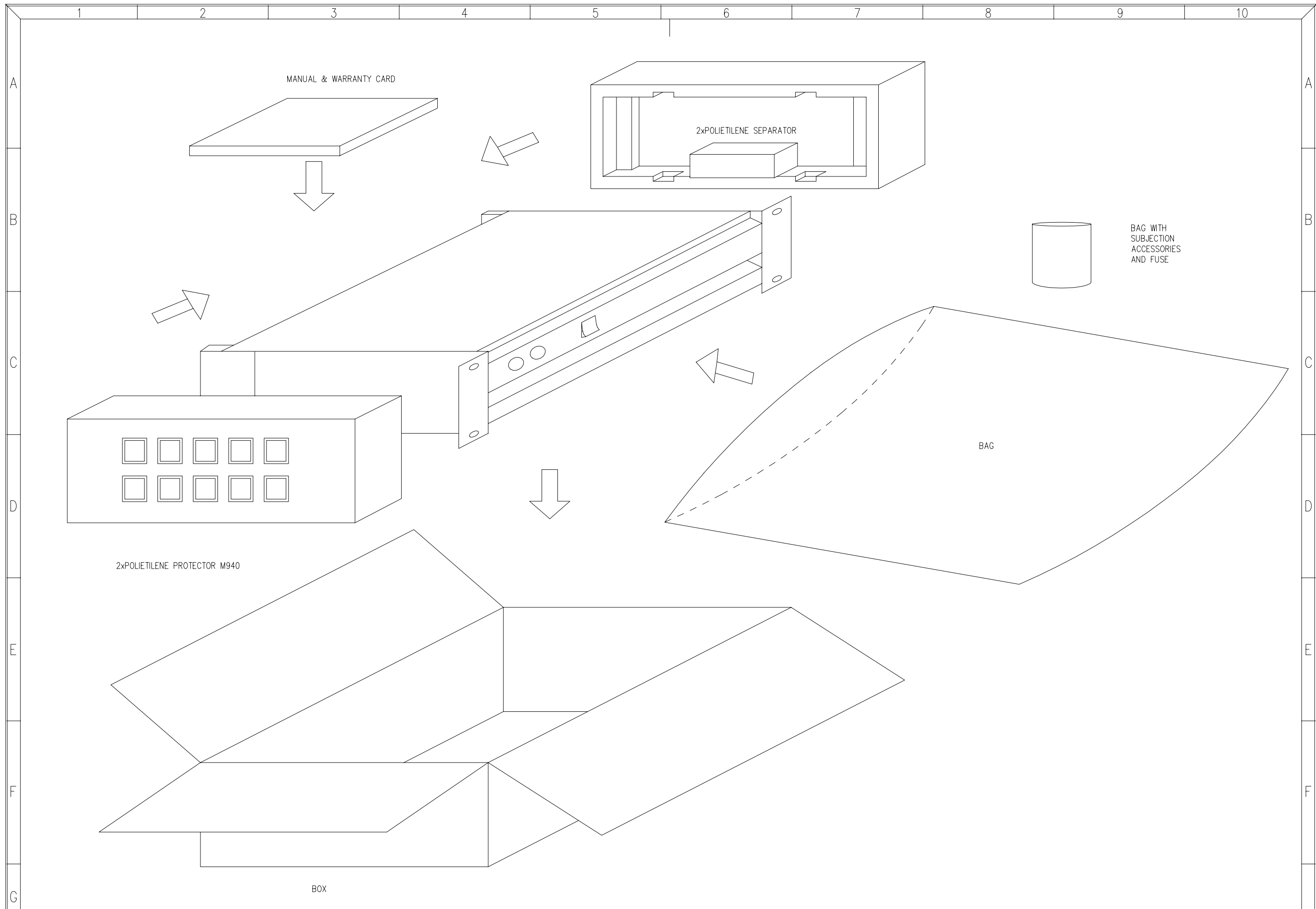

TITLE: PACKING DIAGRAM		MODEL: PAM600/300		 LABORATORIO DE ELECTRO-ACUSTICA BARCELONA ESPAÑA	
DRAWN: J.QUERALT		DATE: 091293			
CHECKED:		DATE:		REPLACED BY:	REV.

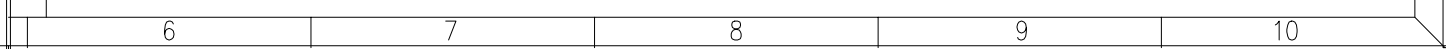

PARTS LIST:
MODEL:PAM600/300
DATE: 091293

PACKING DIAGRAM
DRW.N° 32.0002PL
SHEET 1 OF 1

REV:
REPLACES:
REPLACED BY:

QUANTITY DESCRIPT

4 METAL WASHER 5x11,5x0,8
4 WASHER AT 5x11,5x3,5 ABS BLACK
1 FUSE 16A 6x32TI PO90610
1 BOX PAM1400
2 POLIETILENE PROTECTOR M940
1 CASE MANUAL 21,5x32,5
1 PLASTIC BAG 75x65
1 BAG 60x80
1 MANUAL PAM1400
1 WARRANTY CARD
2 POLIETILENE SEPARATOR

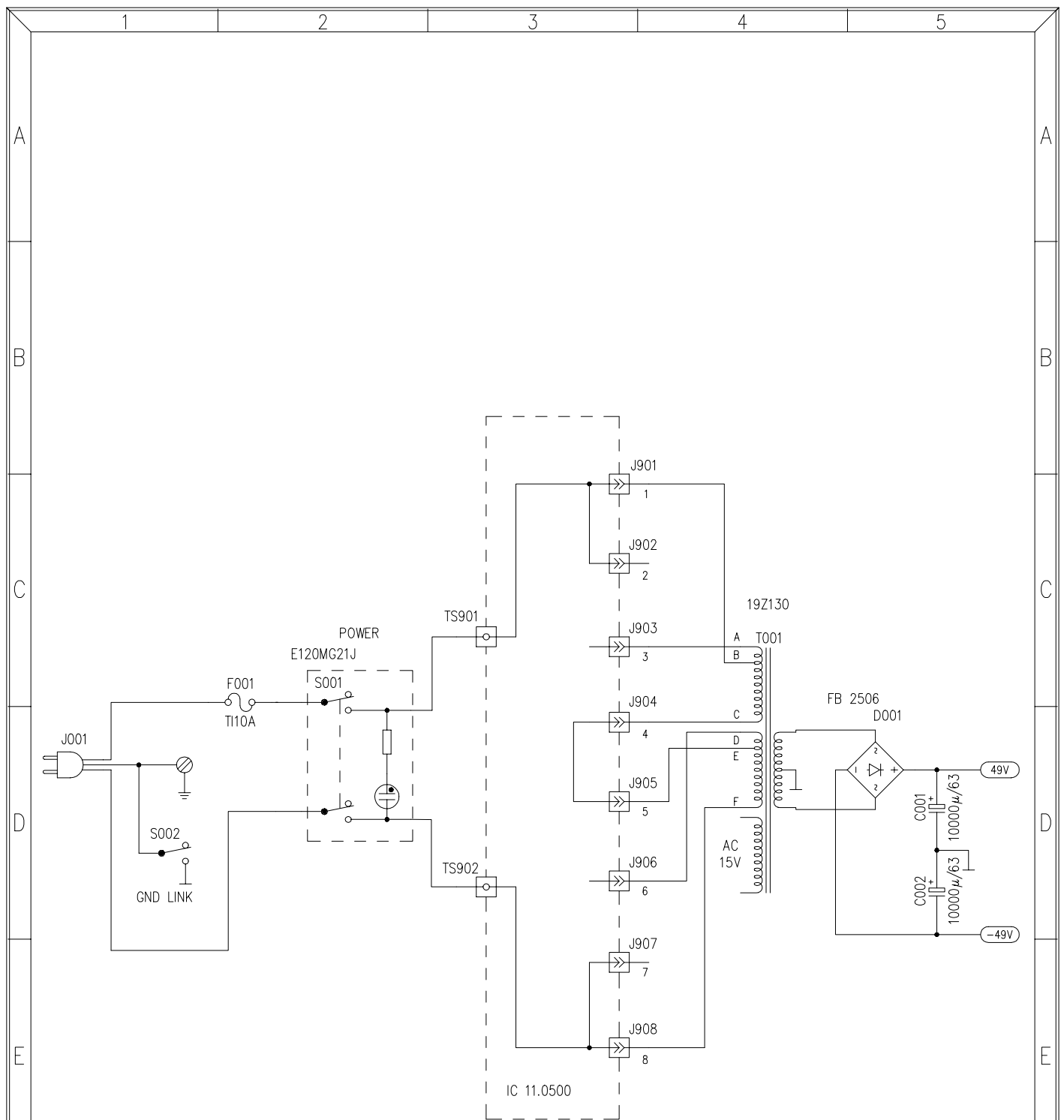

All capacitors 63 V, unless otherwise noted.
 Resistors in Ohms. Capacitors in Farads. Inductors in Henries.
 All resistors 1/4 W, unless otherwise noted.
 See parts list for more information about components.

Special schematic abbreviations:
 W wounded wire resistor
 C ceramic capacitor

	<u>110 V</u>	<u>120 V</u>	<u>220 V</u>	<u>230 V</u>	<u>240 V</u>
1 -	B	A	B	A	A
2 -	E	D	-	-	-
3 -	A	B	A	B	B
4 -	-	-	C	C	C
5 -	-	-	E	E	D
6 -	D	E	D	D	E
7 -	C	C	-	-	-
8 -	F	F	F	F	F

TITLE: POWER CIRCUIT		MODEL: PAM300		 LABORATORIO DE ELECTRO-ACUSTICA BARCELONA ESPAÑA	
DRAWN: J.QUERALT		SHEET 1 OF 6			
DATE: 011093		REPLACES:		DRW. NO. 10.0235	
CHECKED:		REPLACED BY:		REV.	

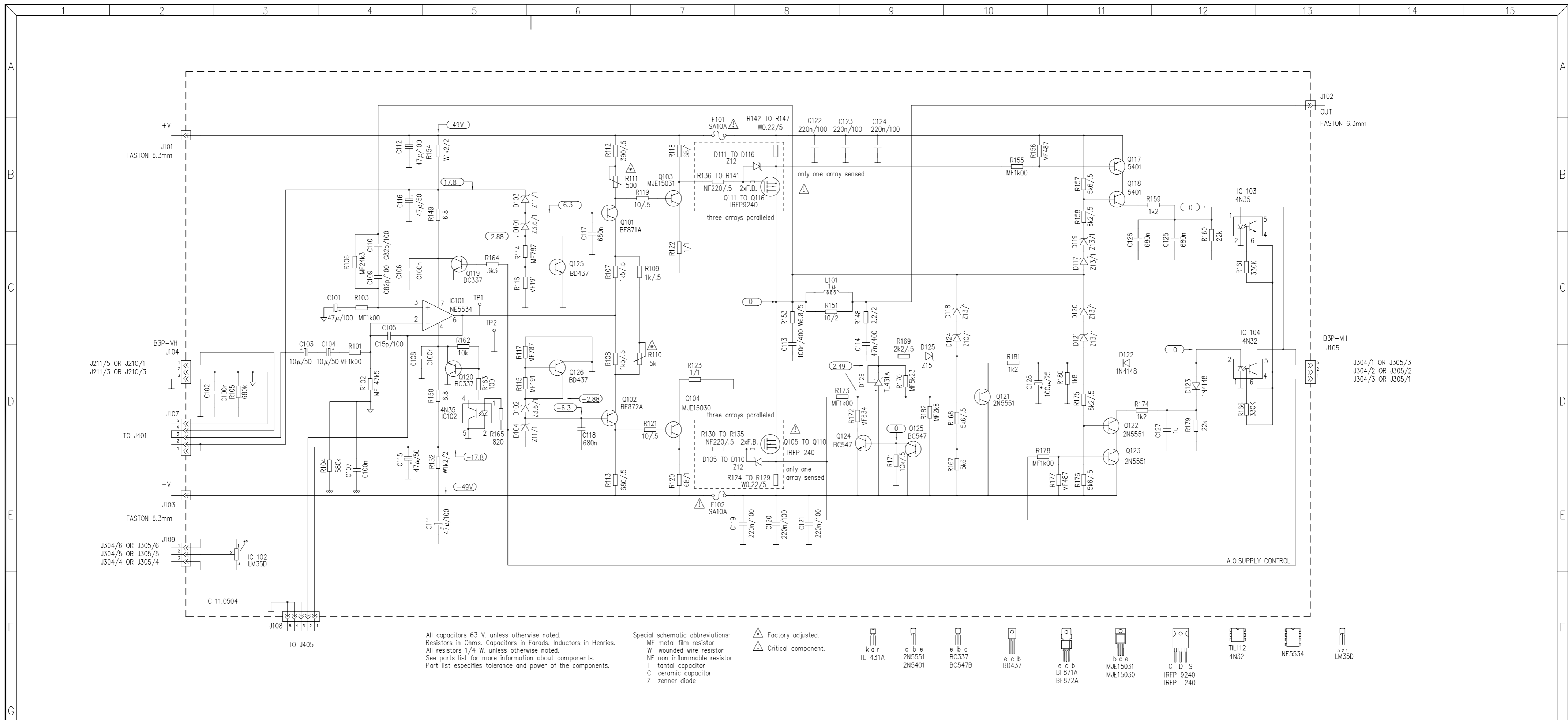

All capacitors 63 V, unless otherwise noted.
Resistors in Ohms. Capacitors in Farads. Inductors in Henries.
All resistors 1/4 W, unless otherwise noted.
See parts list for more information about components.
Part list specifies tolerance and power of the components.

Special schematic abbreviations:
MF metal film resistor
W wounded wire resistor
NF non inflammable resistor
T tantal capacitor
C ceramic capacitor
Z zener diode

Factory adjusted.
Critical component.

- kar TL 431A
- c b e 2N5551
- e b c BC337
- e b c BC547B
- e c b BD437
- e c b BF871A
- e c b BF872A
- b c e MJE15031
- b c e MJE15030
- G D S IRFP 9240
- G D S IRFP 240
- TL112 4N32
- NE5534
- 3 2 1 LM35D

TITLE: POWER CIRCUIT AND SHORT CIRCUIT PROTECTION SCHEMATIC DIAGRAM		MODEL: PAM300 Switching Mosfet Power Amplifier		 LABORATORIO DE ELECTRO-ACUSTICA BARCELONA ESPAÑA	
DRAWN: J.QUERALT		DATE: 071093			
CHECKED:		DATE:		REPLACES:	DRW. NO. 10.0239
				REPLACED BY:	REV. A

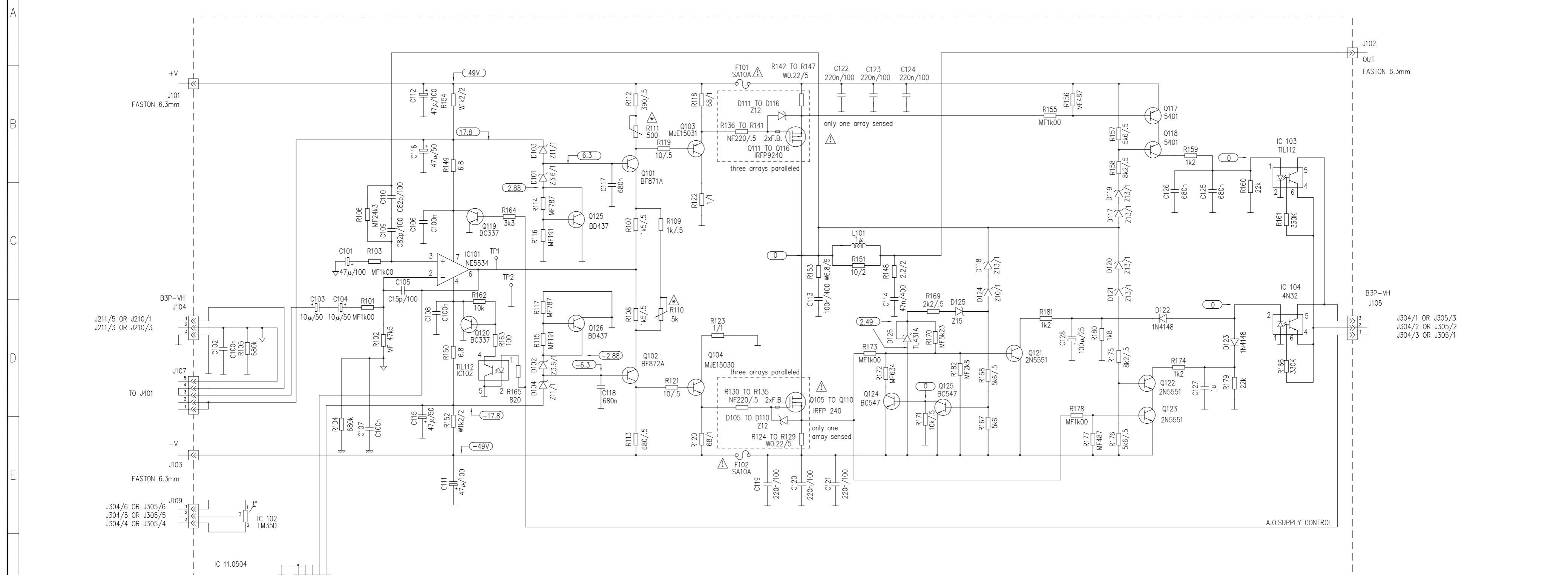

OLD VERSION

All capacitors 63 V, unless otherwise noted.
Resistors in Ohms. Capacitors in Farads. Inductors in Henries.
All resistors 1/4 W, unless otherwise noted.
See parts list for more information about components.
Part list specifies tolerance and power of the components.

Special schematic abbreviations:
MF metal film resistor
W wounded wire resistor
NF non inflammable resistor
T tantal capacitor
C ceramic capacitor
Z zenner diode

- ▲ Factory adjusted.
- ▲ Critical component.
- kar TL 431A
- c b e 2N5551
- e b c BC337
- e c b BC547B
- e c b BD437
- e c b BF871A
- b c e MJE15031
- G D S IRFP 9240
- IRFP 240
- TIL112 4N32
- NE5534
- 3 2 1 LM35D

TITLE: POWER CIRCUIT AND SHORT CIRCUIT PROTECTION SCHEMATIC DIAGRAM		MODEL: PAM300 Switching Mosfet Power Amplifier		 LABORATORIO DE ELECTRO-ACUSTICA BARCELONA ESPAÑA
DRAWN: J.QUERALT		DATE: 071093		
CHECKED:		DATE:		DRW. NO. 10.0239
		REPLACES:		REV.
		REPLACED BY:		

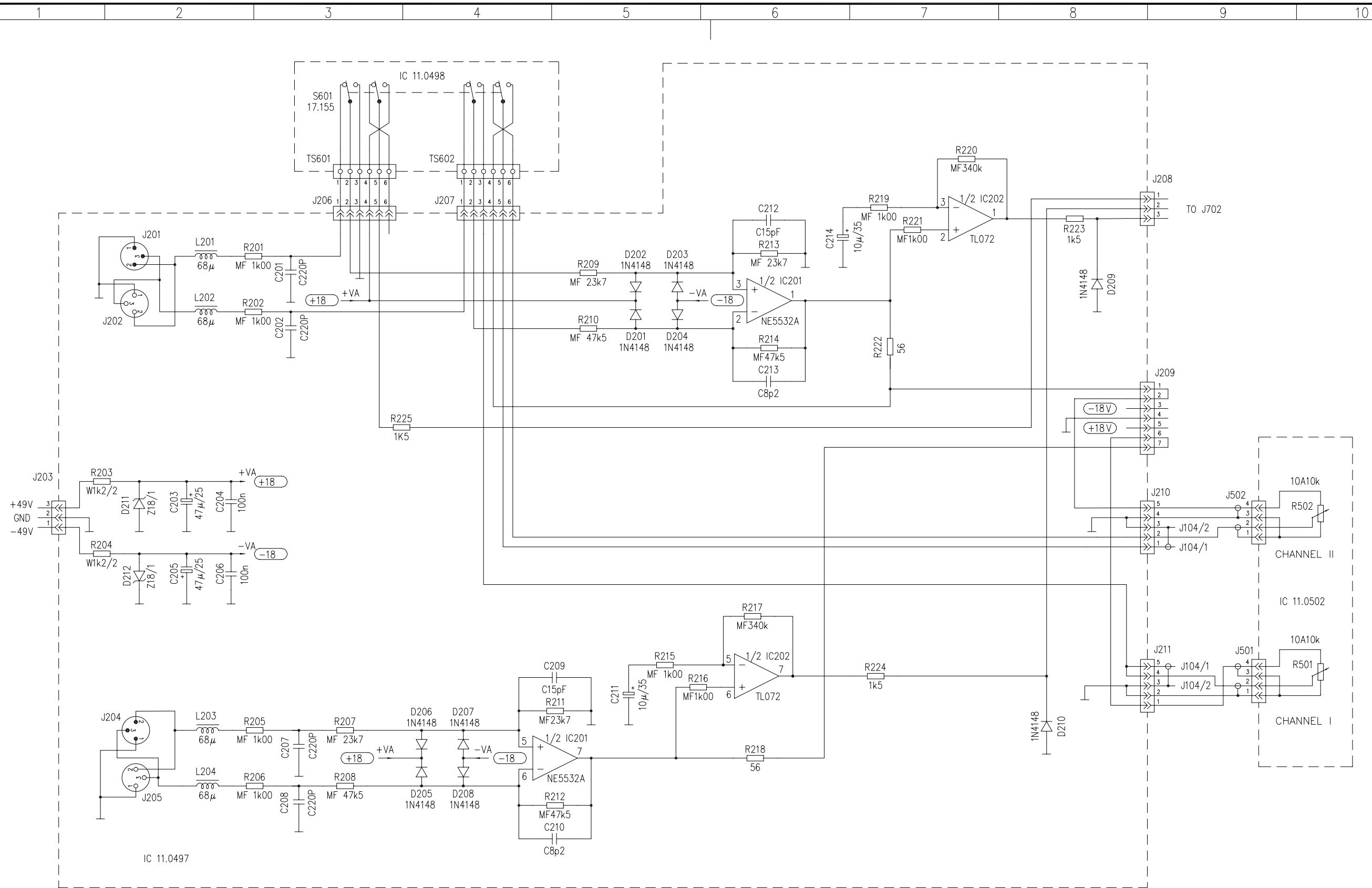

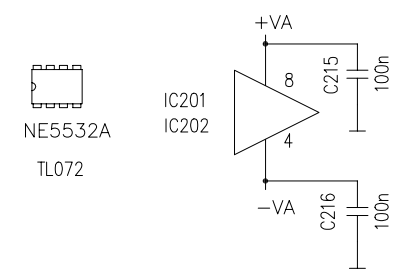

All capacitors 63 V, unless otherwise noted.
 Resistors in Ohms. Capacitors in Farads. Inductors in Henries.
 All resistors 1/4 W, unless otherwise noted.
 See parts list for more information about components.
 Part list specifies tolerance and power of the components.

Special schematic abbreviations:
 MF metal film resistor
 W wounded wire resistor
 NF non inflammable resistor
 T tantal capacitor
 C ceramic capacitor
 Z zener diode

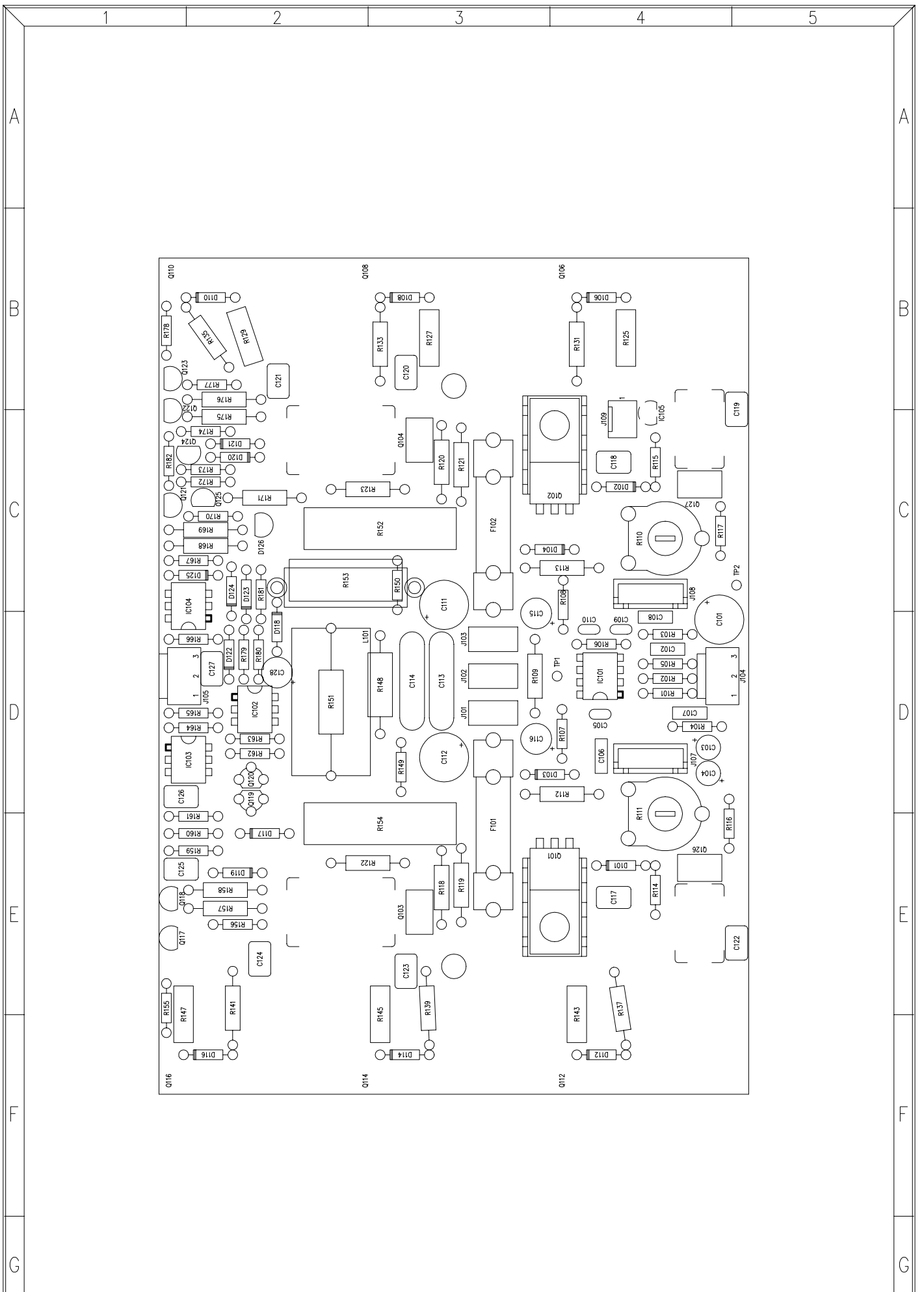

TITLE: INPUT CIRCUIT		MODEL: PAM300 Switching Power Mosfet Amplifier		 LABORATORIO DE ELECTRO-ACUSTICA BARCELONA ESPAÑA	
DRAWN: J.QUERALT		DATE: 300993			
CHECKED:		DATE:		REPLACES:	
		DATE:		REPLACED BY:	
				DRW. NO. 10.0231	
				REV.	



TITLE: POWER CIRCUIT AND SHORT CIRCUIT PROTECTION		MODEL: PAM300		 LABORATORIO DE ELECTRO-ACUSTICA BARCELONA ESPAÑA	
DRAWN: J.QUERALT		SHEET 1 OF 7			
DATE: 081193		REPLACES:		DRW. NO.	REV.
CHECKED:		REPLACED BY:		33.0012 R/	C

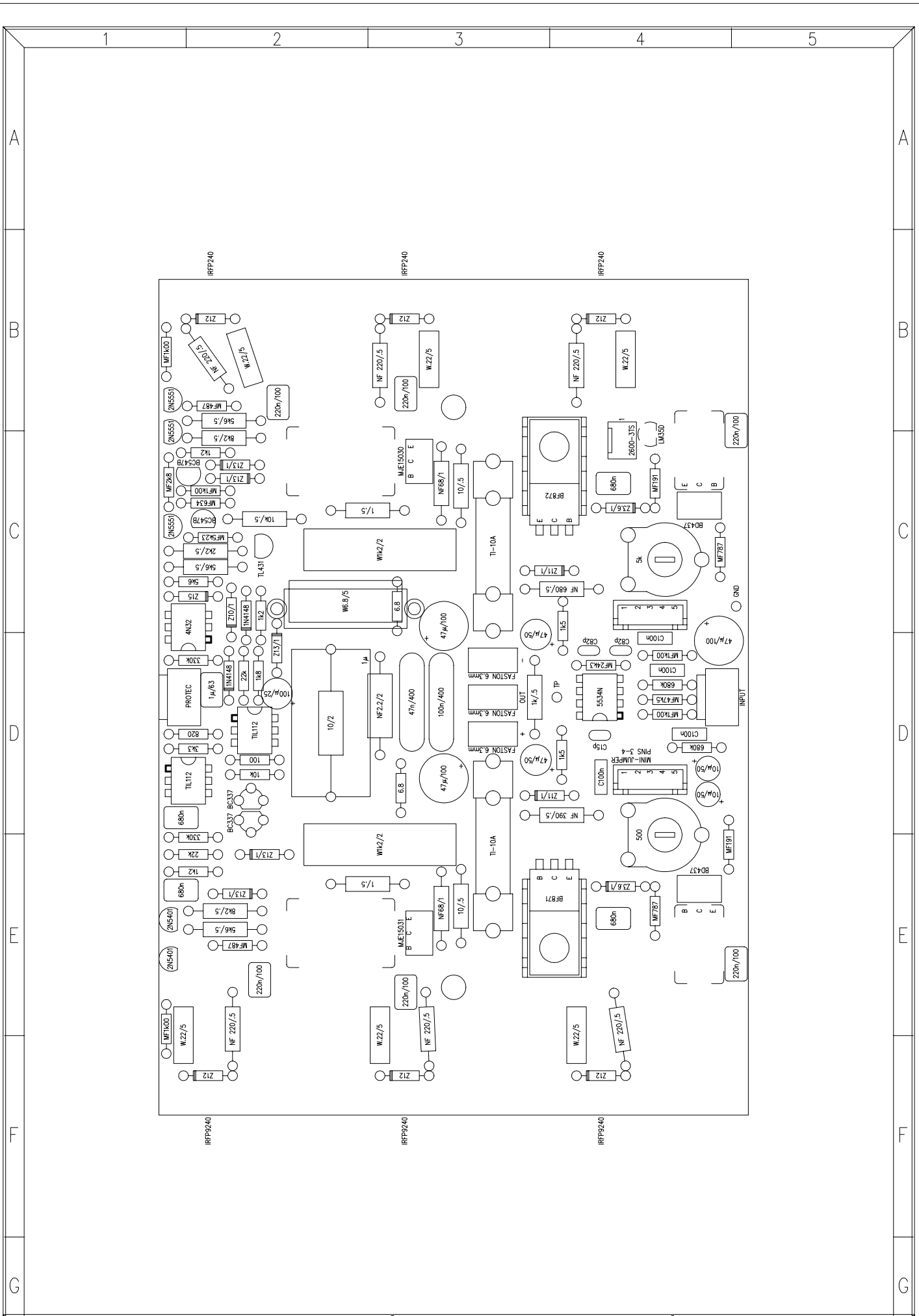

TITLE: POWER CIRCUIT AND SHORT CIRCUIT PROTECTION		MODEL: PAM300		 LABORATORIO DE ELECTRO-ACUSTICA BARCELONA ESPAÑA	
DRAWN: J.QUERALT		SHEET 1 OF 7			
DATE: 081193		REPLACES:		DRW. NO.	REV.
CHECKED:		REPLACED BY:		33.0012 v/	C

PARTS LIST:
MODEL:PAM300
DATE: 000621

POWER CIRCUIT AND SHORT CIRCUIT PROTECTION
DRW.N° 33.0012PL REV : A
SHEET 1 OF 3 REPLACED BY:

REFERENCE	VALUE
C101	47μ/100
C102	C100n
C103	10μ/50
C104	10μ/50
C105	C15p
C106	C100n
C107	C100n
C108	C100n
C109	C82p
C110	C82p
C111	47μ/100
C112	47μ/100
C113	100n/400
C114	47n/400
C115	47μ/50
C116	47μ/50
C117	680n
C118	680n
C119	220n/100
C120	220n/100
C121	220n/100
C122	220n/100
C123	220n/100
C124	220n/100
C125	680n
C126	680n
C127	1μ/63
C128	100μ/25
CTO 11.0504	CTO.FRA.CU.
D101	Z3.6/1
D102	Z3.6/1
D103	Z11/1
D104	Z11/1
D106	Z12
D108	Z12
D110	Z12
D112	Z12
D114	Z12
D116	Z12
D117	Z13/1
D118	Z13/1
D119	Z13/1
D120	Z13/1
D121	Z13/1
D122	1N4148
D123	1N4148
D124	Z10/1
D125	Z15
D126	TL431
F101	TI-10A
F102	TI-10A
IC101	5534N
IC102	4N35
IC103	4N35
IC104	4N32
IC105	LM35D
J101	FASTON 6.3mm
J102	FASTON 6.3mm

PARTS LIST:
MODEL:PAM300
DATE: 000621

POWER CIRCUIT AND SHORT CIRCUIT PROTECTION
DRW.N° 33.0012PL REV : A
SHEET 2 OF 3 REPLACED BY:

REFERENCE	VALUE
J103	FASTON 6.3mm
J104	B3P-VH
J105	B3P-VH
J107	B5B-XH
J108	B5B-XH
J109	2600-3TS
Q101	BF871
Q102	BF872
Q103	MJE15031
Q104	MJE15030
Q106	IRFP240
Q108	IRFP240
Q110	IRFP240
Q112	IRFP9240
Q114	IRFP9240
Q116	IRFP9240
Q117	2N5401
Q118	2N5401
Q119	BC337
Q120	BC337
Q121	2N5551
Q122	2N5551
Q123	2N5551
Q124	BC547B
Q125	BC547B
Q126	BD437
Q127	BD437
R101	MF1k00
R102	MF47k5
R103	MF1k00
R104	680k
R105	680k
R106	MF24k3
R107	1k5
R108	1k5
R109	1k/.5
R110	5k
R111	500O
R112	NF 390O/.5
R113	NF 680O/.5
R114	MF787O
R115	MF191O
R116	MF191O
R117	MF787O
R118	NF68O/1
R119	10O/.5
R120	NF68O/1
R121	10O/.5
R122	1O/.5
R123	1O/.5
R125	W.22O/5
R127	W.22O/5
R129	W.22O/5
R131	NF22O/.5
R133	NF22O/.5
R135	NF22O/.5
R137	NF22O/.5
R139	NF22O/.5

PARTS LIST:
MODEL:PAM300
DATE: 000621

POWER CIRCUIT AND SHORT CIRCUIT PROTECTION
DRW.N° 33.0012PL REV : A
SHEET 3 OF 3 REPLACED BY:

REFERENCE	VALUE
R141	NF220/.5
R143	W.220/5
R145	W.220/5
R147	W.220/5
R148	NF2.20/2
R149	6.80
R150	6.80
R151	100/2
R152	W1k2/2
R153	W6.80/5
R154	W1k2/2
R155	MF1k00
R156	MF487O
R157	5k6/.5
R158	8k2/.5
R159	1k2
R160	22k
R161	330k
R162	10k
R163	1000
R164	3k3
R165	8200
R166	330k
R167	5k6
R168	5k6/.5
R169	2k2/.5
R170	MF5k23
R171	10k/.5
R172	MF634
R173	MF1k00
R174	1k2
R175	8k2/.5
R176	5k6/.5
R177	MF487O
R178	MF1k00
R179	22k
R180	1k8
R181	1k2
R182	MF2k8

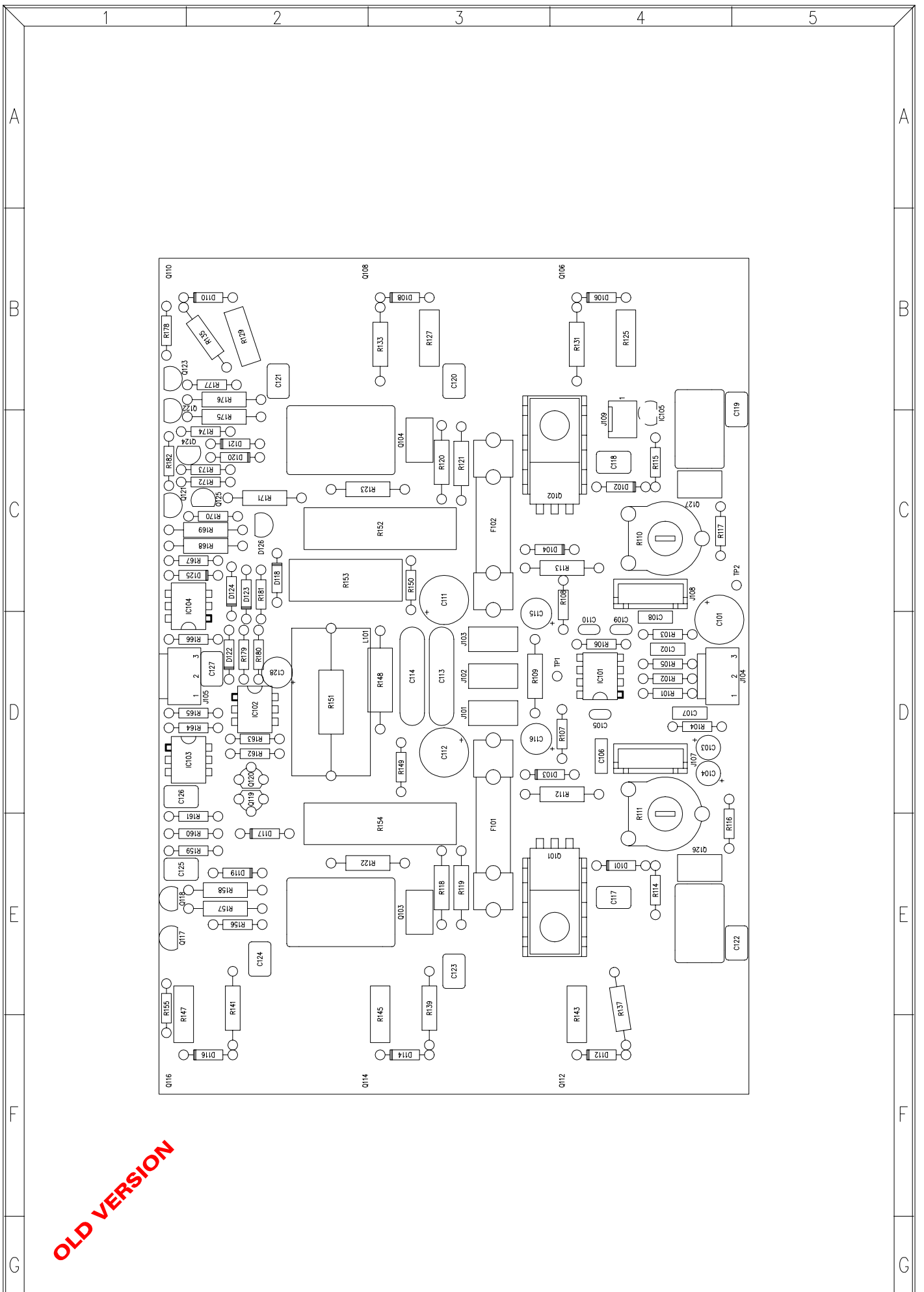

OLD VERSION

TITLE: POWER CIRCUIT AND SHORT CIRCUIT PROTECTION		MODEL: PAM300		ECLEROO	
DRAWN: J.QUERALT		DATE: 081193		LABORATORIO DE ELECTRO-ACUSTICA BARCELONA ESPAÑA	
CHECKED:		DATE:		REPLACES: REPLACED BY:	
				DRW. NO. 33.0012 R/	
				REV. A	

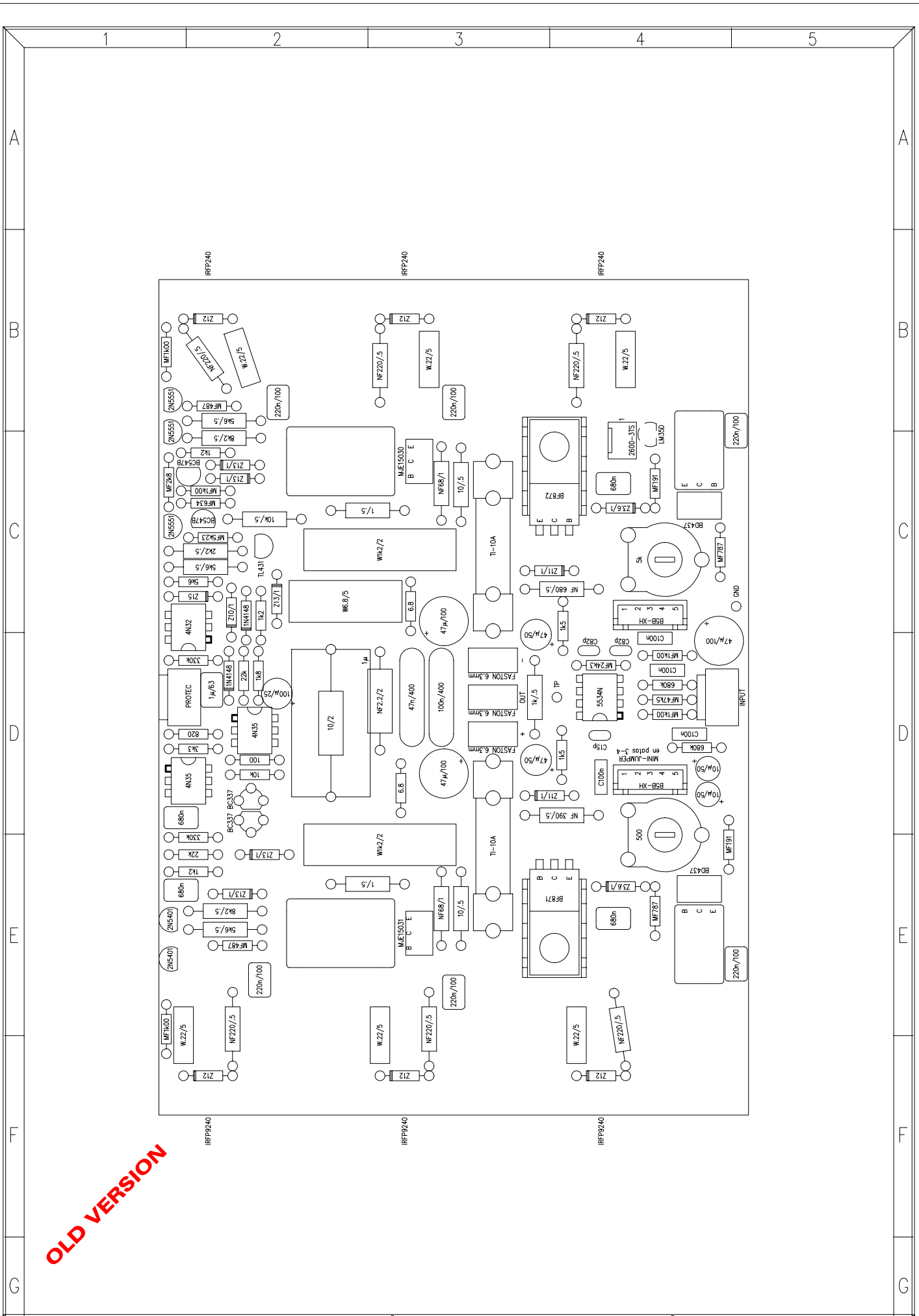

OLD VERSION

TITLE: POWER CIRCUIT AND SHORT CIRCUIT PROTECTION		MODEL: PAM300		 LABORATORIO DE ELECTRO-ACUSTICA BARCELONA ESPAÑA	
DRAWN: J.QUERALT		SHEET 1 OF 7			
DATE: 081193		REPLACES:		DRW. NO.	REV.
CHECKED:		REPLACED BY:		33.0012 v/	A

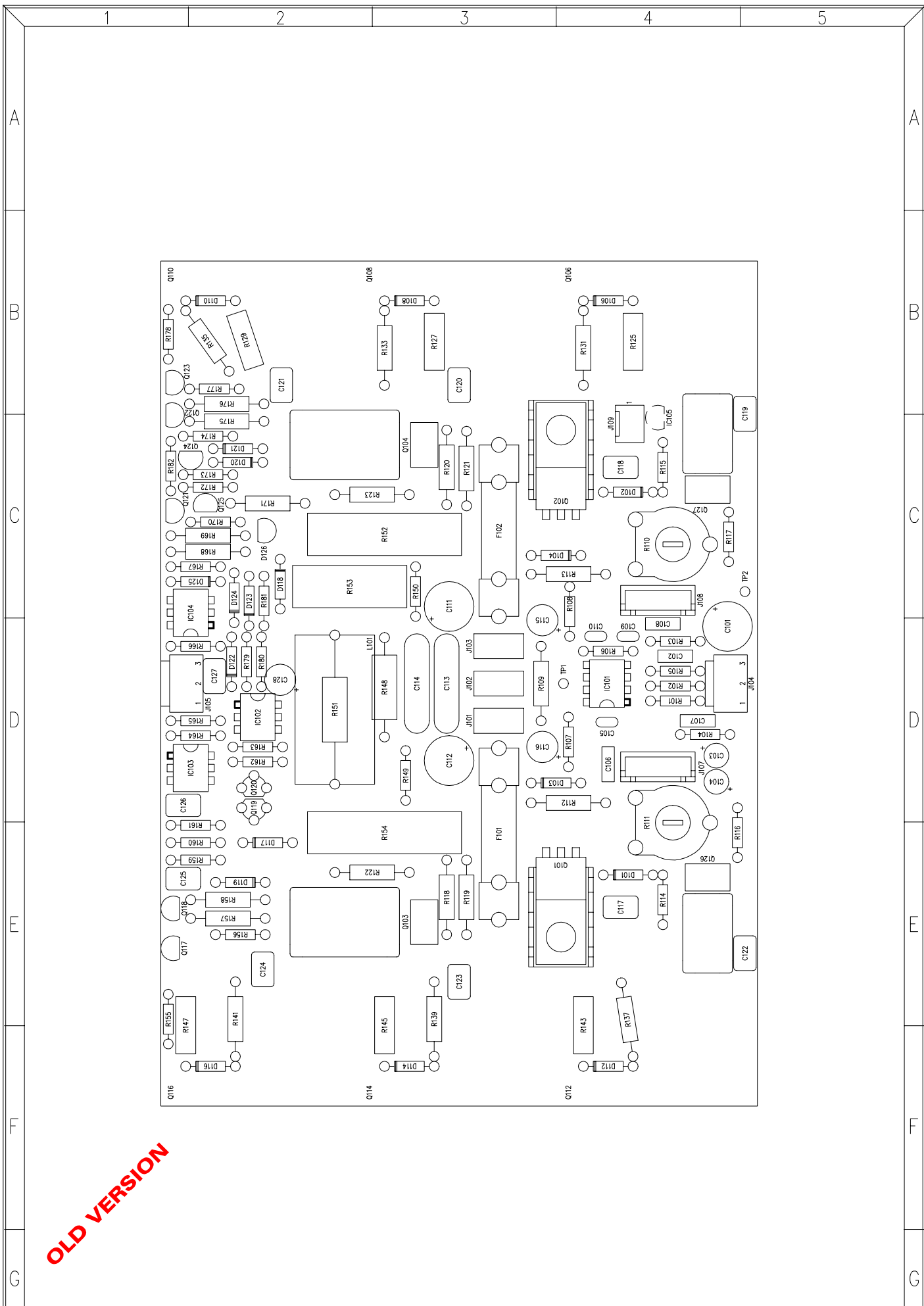

OLD VERSION

TITLE: POWER CIRCUIT AND SHORT CIRCUIT PROTECTION		MODEL: PAM300		ECLEROO	
DRAWN: J.QUERALT		DATE: 081193		LABORATORIO DE ELECTRO-ACUSTICA BARCELONA ESPAÑA	
CHECKED:		DATE:		REPLACES:	
				REPLACED BY:	
		SHEET 1 OF 7		DRW. NO. 33.0012 R/	
				REV.	

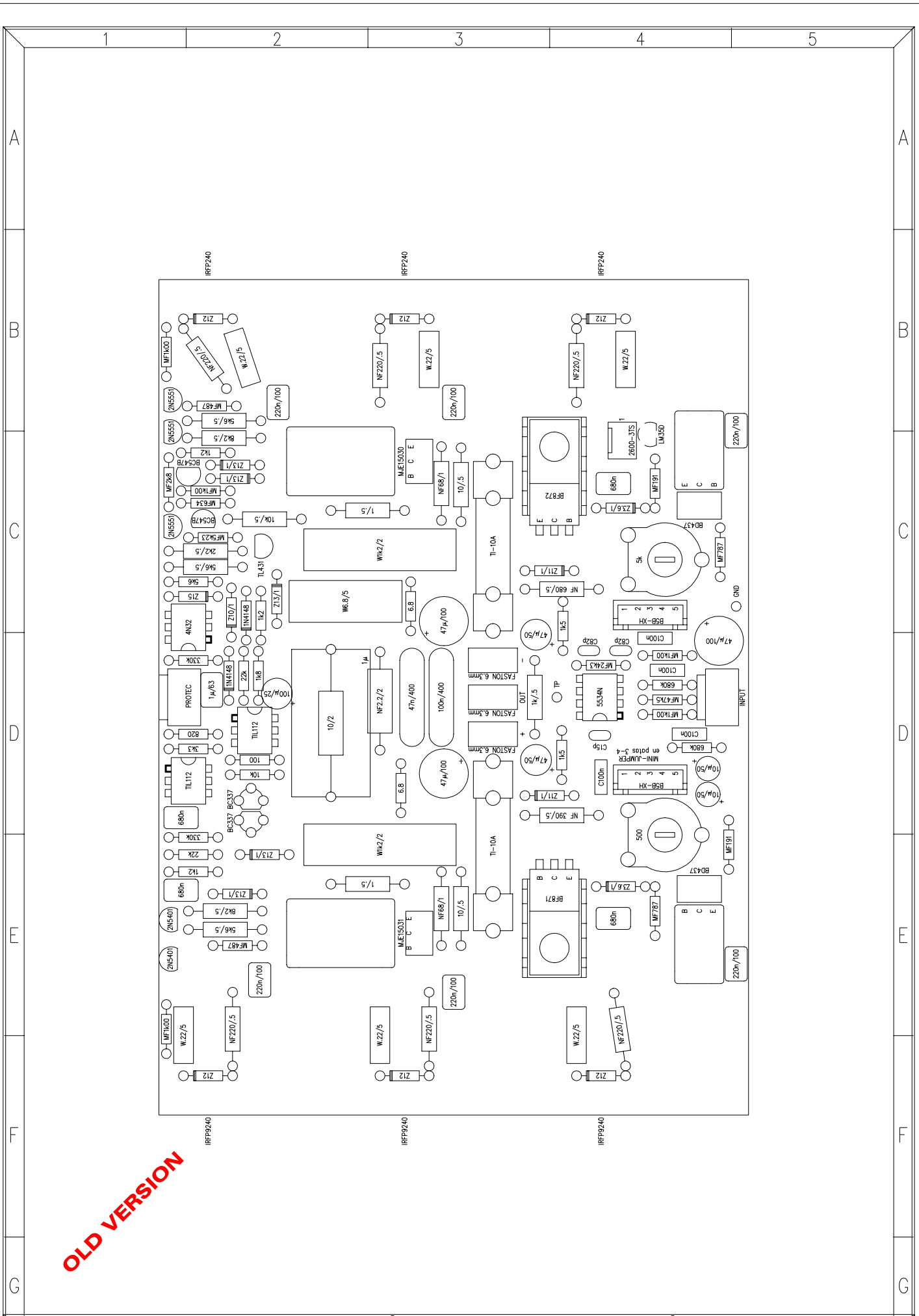

OLD VERSION

TITLE: POWER CIRCUIT AND SHORT CIRCUIT PROTECTION		MODEL: PAM300		 LABORATORIO DE ELECTRO-ACUSTICA BARCELONA ESPAÑA	
DRAWN: J.QUERALT		SHEET 1 OF 7			
DATE: 081193		REPLACES:		DRW. NO.	REV.
CHECKED:		REPLACED BY:		33.0012 v/	

PARTS LIST:
MODEL:PAM300
DATE: 081193

POWER CIRCUIT AND SHORT CIRCUIT PROTECTION
DRW.N° 33.0012PL REV :
SHEET 1 OF 3 REPLACED BY:

REFERENCE	VALUE
C101	47μ/100
C102	C100n
C103	10μ/50
C104	10μ/50
C105	C15p
C106	C100n
C107	C100n
C108	C100n
C109	C82p
C110	C82p
C111	47μ/100
C112	47μ/100
C113	100n/400
C114	47n/400
C115	47μ/50
C116	47μ/50
C117	680n
C118	680n
C119	220n/100
C120	220n/100
C121	220n/100
C122	220n/100
C123	220n/100
C124	220n/100
C125	680n
C126	680n
C127	1μ/63
C128	100μ/25
CTO 11.0504	CTO.FRA.CU.
D101	Z3.6/1
D102	Z3.6/1
D103	Z11/1
D104	Z11/1
D106	Z12
D108	Z12
D110	Z12
D112	Z12
D114	Z12
D116	Z12
D117	Z13/1
D118	Z13/1
D119	Z13/1
D120	Z13/1
D121	Z13/1
D122	1N4148
D123	1N4148
D124	Z10/1
D125	Z15
D126	TL431
F101	TI-10A
F102	TI-10A
IC101	5534N
IC102	TIL112
IC103	TIL112
IC104	4N32
IC105	LM35D
J101	FASTON 6.3mm
J102	FASTON 6.3mm

OLD VERSION

PARTS LIST:
MODEL:PAM300
DATE: 081193

POWER CIRCUIT AND SHORT CIRCUIT PROTECTION
DRW.N° 33.0012PL REV :
SHEET 2 OF 3 REPLACED BY:

REFERENCE	VALUE
J103	FASTON 6.3mm
J104	B3P-VH
J105	B3P-VH
J107	B5B-XH
J108	B5B-XH
J109	2600-3TS
Q101	BF871
Q102	BF872
Q103	MJE15031
Q104	MJE15030
Q106	IRFP240
Q108	IRFP240
Q110	IRFP240
Q112	IRFP9240
Q114	IRFP9240
Q116	IRFP9240
Q117	2N5401
Q118	2N5401
Q119	BC337
Q120	BC337
Q121	2N5551
Q122	2N5551
Q123	2N5551
Q124	BC547B
Q125	BC547B
Q126	BD437
Q127	BD437
R101	MF1k00
R102	MF47k5
R103	MF1k00
R104	680k
R105	680k
R106	MF24k3
R107	1k5
R108	1k5
R109	1k/.5
R110	5k
R111	500O
R112	NF 390O/.5
R113	NF 680O/.5
R114	MF787O
R115	MF191O
R116	MF191O
R117	MF787O
R118	NF68O/1
R119	10O/.5
R120	NF68O/1
R121	10O/.5
R122	1O/.5
R123	1O/.5
R125	W.22O/5
R127	W.22O/5
R129	W.22O/5
R131	NF22O/.5
R133	NF22O/.5
R135	NF22O/.5
R137	NF22O/.5
R139	NF22O/.5

OLD VERSION

PARTS LIST:
MODEL:PAM300
DATE: 081193

POWER CIRCUIT AND SHORT CIRCUIT PROTECTION
DRW.N° 33.0012PL REV :
SHEET 3 OF 3 REPLACED BY:

REFERENCE	VALUE
R141	NF220/.5
R143	W.220/5
R145	W.220/5
R147	W.220/5
R148	NF2.20/2
R149	6.80
R150	6.80
R151	100/2
R152	W1k2/2
R153	W6.80/5
R154	W1k2/2
R155	MF1k00
R156	MF487O
R157	5k6/.5
R158	8k2/.5
R159	1k2
R160	22k
R161	330k
R162	10k
R163	1000
R164	3k3
R165	8200
R166	330k
R167	5k6
R168	5k6/.5
R169	2k2/.5
R170	MF5k23
R171	10k/.5
R172	MF634
R173	MF1k00
R174	1k2
R175	8k2/.5
R176	5k6/.5
R177	MF487O
R178	MF1k00
R179	22k
R180	1k8
R181	1k2
R182	MF2k8

OLD VERSION

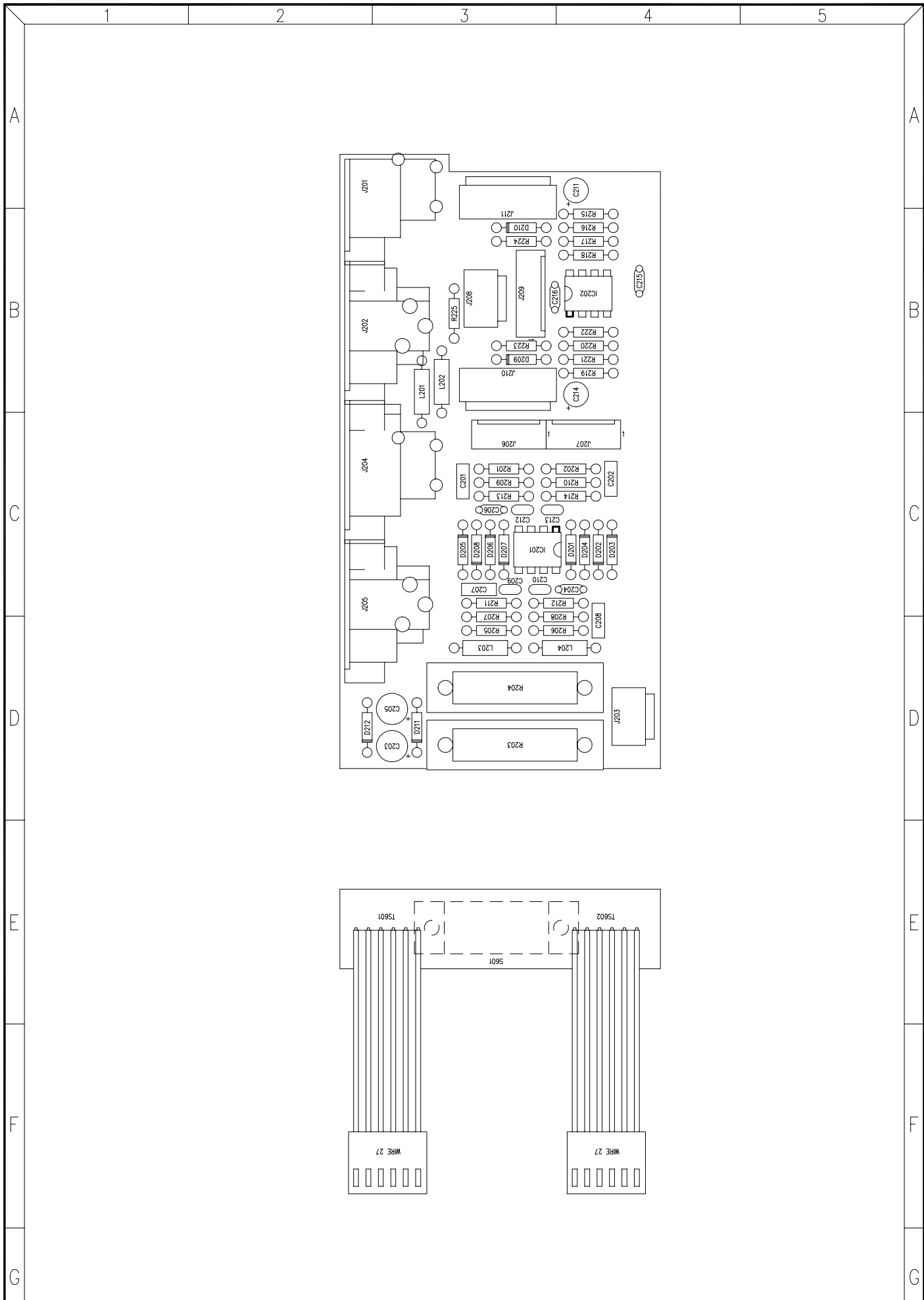

TITLE: INPUT CIRCUIT		MODEL: PAM300	 LABORATORIO DE ELECTRO-ACUSTICA BARCELONA ESPAÑA	
		SHEET 2 OF 7		
DRAWN: J.QUERALT	DATE: 081193	REPLACES:	DRW. NO. 33.0211 R/	REV.
CHECKED:	DATE:	REPLACED BY:		

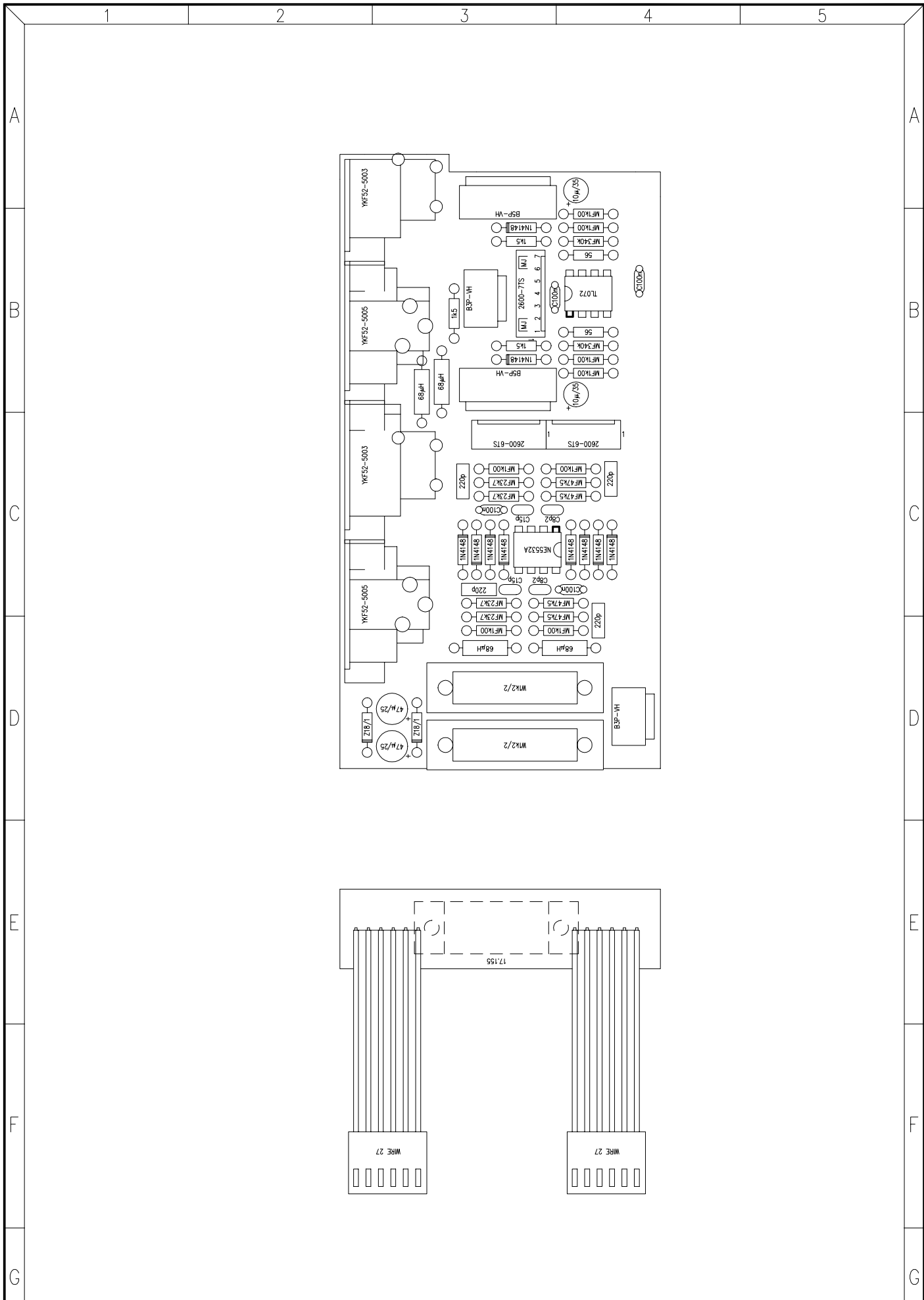

TITLE: INPUT CIRCUIT		MODEL: PAM300		 LABORATORIO DE ELECTRO-ACUSTICA BARCELONA ESPAÑA	
		SHEET 2 OF 7			
DRAWN: J.QUERALT	DATE: 081193	REPLACES:		DRW. NO. 33.0211 V/	REV.
CHECKED:	DATE:	REPLACED BY:			

PARTS LIST:
MODEL:PAM300
DATE: 091293

INPUT CIRCUIT
DRW.N° 33.0211PL
SHEET 1 OF 2

REV:
REPLACES:
REPLACED BY:

REFERENCE	DESCRIPT
C201	220p
C202	220p
C203	47 μ /25
C204	C100n
C205	47 μ /25
C206	C100n
C207	220p
C208	220p
C209	C15p
C210	C8p2
C211	10 μ /35
C212	C15p
C213	C8p2
C214	10 μ /35
C215	C100n
C216	C100n
CTO 11.497-8	CTO.FRA.CU.
D201	1N4148
D202	1N4148
D203	1N4148
D204	1N4148
D205	1N4148
D206	1N4148
D207	1N4148
D208	1N4148
D209	1N4148
D210	1N4148
D211	Z18/1
D212	Z18/1
IC201	NE5532A
IC202	TL072
J201	YKF52-5003
J202	YKF52-5005
J203	B3P-VH
J204	YKF52-5003
J205	YKF52-5005
J206	2600-6TS
J207	2600-6TS
J208	B3P-VH
J209	2600-7TS
J210	B5P-VH
J211	B5P-VH
L201	68 μ H
L202	68 μ H
L203	68 μ H
L204	68 μ H
R201	MF1k00
R202	MF1k00
R203	W1k2/2
R204	W1k2/2
R205	MF1k00
R206	MF1k00
R207	MF23k7
R208	MF47k5
R209	MF23k7
R210	MF47k5

PARTS LIST:
MODEL:PAM300
DATE: 091293

INPUT CIRCUIT
DRW.N° 33.0211PL
SHEET 2 OF 2

REV:
REPLACES:
REPLACED BY:

REFERENCE	DESCRIPT
R211	MF23k7
R212	MF47k5
R213	MF23k7
R214	MF47k5
R215	MF1k00
R216	MF1k00
R217	MF340k
R218	56
R219	MF1k00
R220	MF340k
R221	MF1k00
R222	56
R223	1k5
R224	1k5
R225	1k5
S601	17.155
WIRE 27	WIRE 27
WIRE 27	WIRE 27

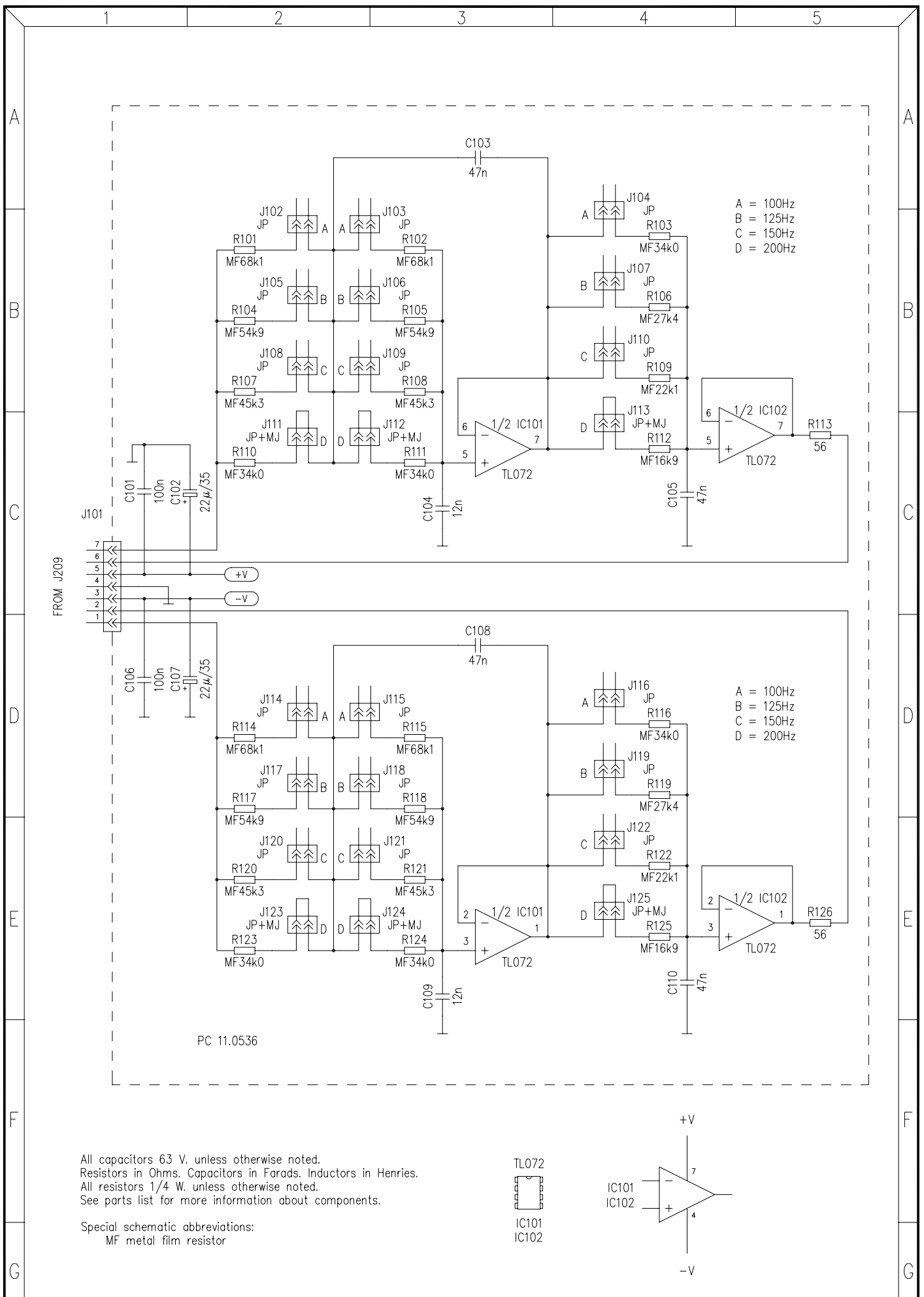

All capacitors 63 V, unless otherwise noted.
Resistors in Ohms. Capacitors in Farads. Inductors in Henries.
All resistors 1/4 W, unless otherwise noted.
See parts list for more information about components.

Special schematic abbreviations:
MF metal film resistor

TL072

IC101
IC102

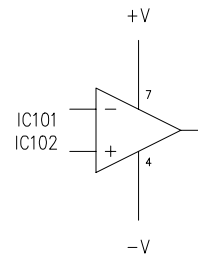

TITLE: LOW PASS FILTER		MODEL: FA2-LP	ECLEROO	
DRAWN: J.QUERALT		DATE: 291194	LABORATORIO DE ELECTRO-ACUSTICA BARCELONA ESPAÑA	
CHECKED:		DATE:	REPLACES:	DRW. NO. 10.0269
		DATE:	REPLACED BY:	REV.

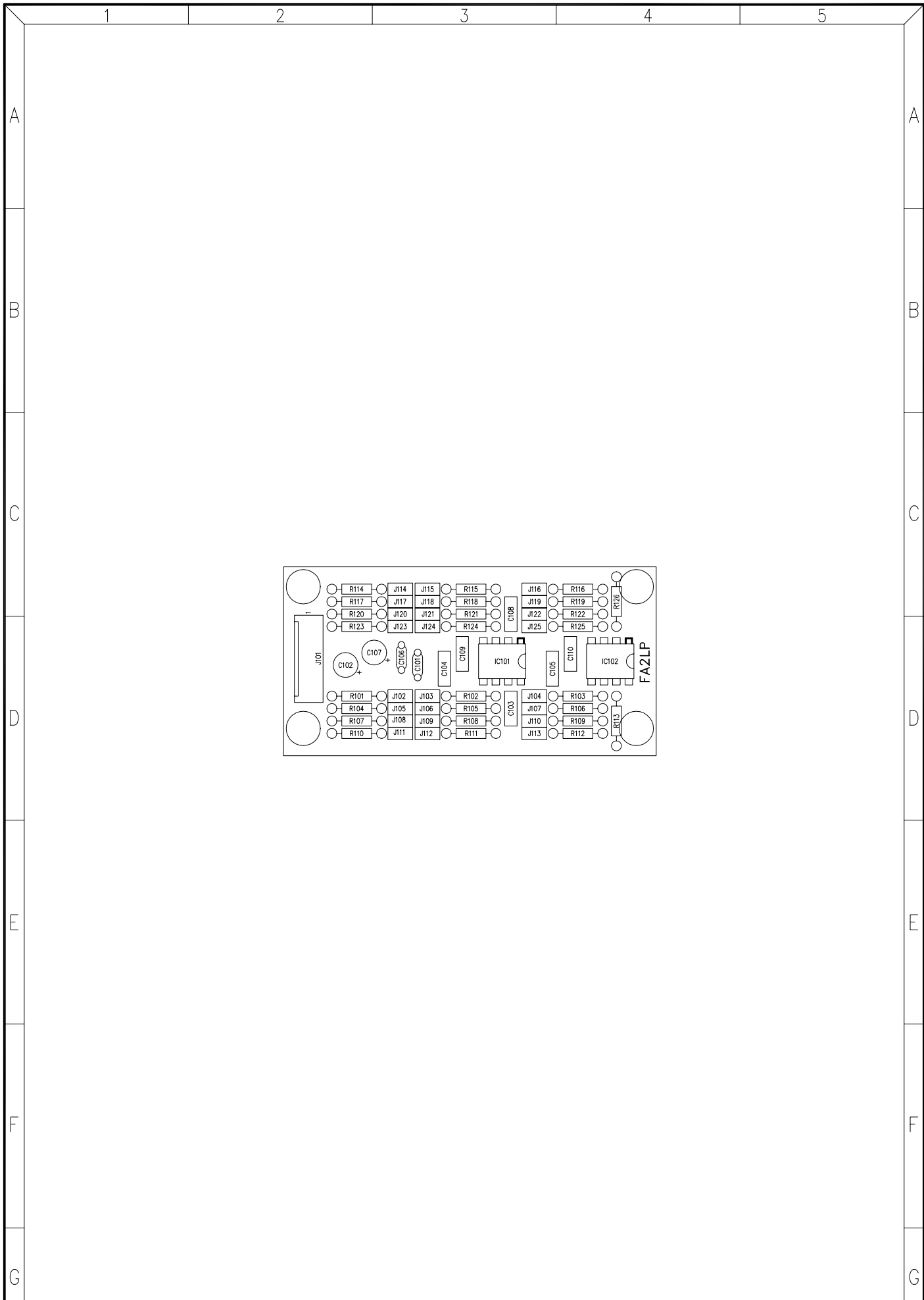

TITLE: LOW PASS FILTER		MODEL: FA2-LP		 LABORATORIO DE ELECTRO-ACUSTICA BARCELONA ESPAÑA	
		SHEET OF			
DRAWN: AMOROS/QUERALT	DATE: 291194	REPLACES:		DRW. NO.	REV.
CHECKED:	DATE:	REPLACED BY:		33.0085 R/	

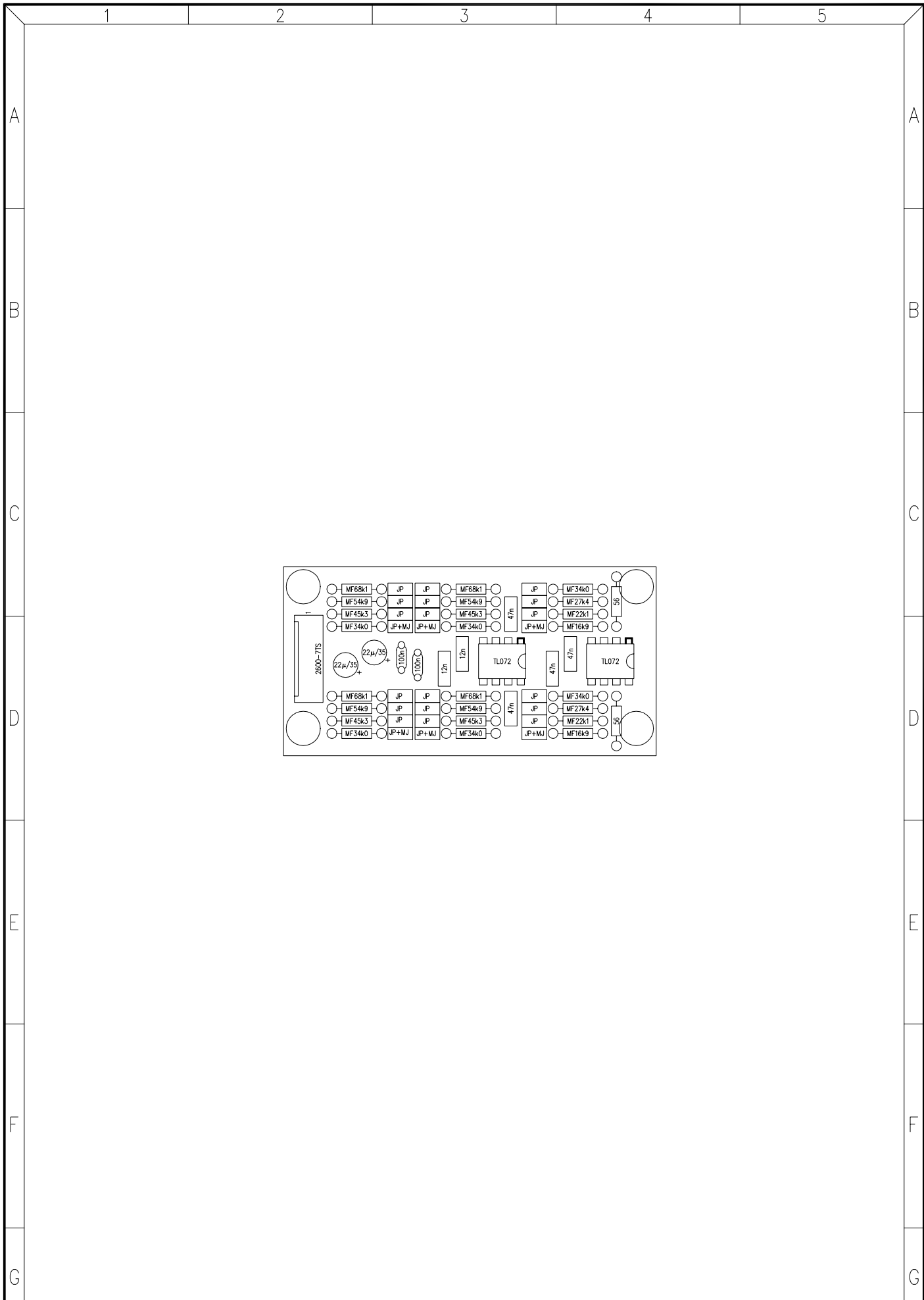

TITLE: LOW PASS FILTER		MODEL: FA2-LP		 LABORATORIO DE ELECTRO-ACUSTICA BARCELONA ESPAÑA	
		SHEET OF			
DRAWN: AMOROS/QUERALT	DATE: 291194	REPLACES:		DRW. NO.	REV.
CHECKED:	DATE:	REPLACED BY:		33.0085	V/

PARTS LIST:
MODEL: FA2-LP
DATE: 291194

LOW PASS FILTER
DRW. No 33.0085PL
SHEET 1 OF 2 REPLACES:

REV:
REPLACED BY:

REFERENCE	VALUE
IC101	TL072
IC102	TL072
C101	100n
C102	22 μ /35
C103	47n
C104	12n
C105	47n
C106	100n
C107	22 μ /35
C108	47n
C109	12n
C110	47n
J101	2600-7TS
J102	JP(JUMPER PIN)
J103	JP
J104	JP
J105	JP
J106	JP
J107	JP
J108	JP
J109	JP
J110	JP
J111	JP+MJ
J112	JP+MJ
J113	JP+MJ
J114	JP
J115	JP
J116	JP
J117	JP
J118	JP
J119	JP
J120	JP
J121	JP
J122	JP
J123	JP+MJ
J124	JP+MJ
J125	JP+MJ
R101	MF68k1
R102	MF68k1
R103	MF34k0
R104	MF54k9
R105	MF54k9
R106	MF27k4
R107	MF45k3
R108	MF45k3
R109	MF22k1
R110	MF34k0
R111	MF34k0
R112	MF16k9
R113	56 Ω
R114	MF68k1
R115	MF68k1
R116	MF34k0
R117	MF54k9
R118	MF54k9
R119	MF27k4

PARTS LIST:
MODEL: FA2-LP
DATE: 291194

LOW PASS FILTER
DRW. No 33.0085PL
SHEET 2 OF 2 REPLACES:

REV:
REPLACED BY:

REFERENCE

VALUE

R120

MF45k3

R121

MF45k3

R122

MF22k1

R123

MF34k0

R124

MF34k0

R125

MF16k9

R126

56Ω

PC 11.0536

PRINTED CIRCUIT

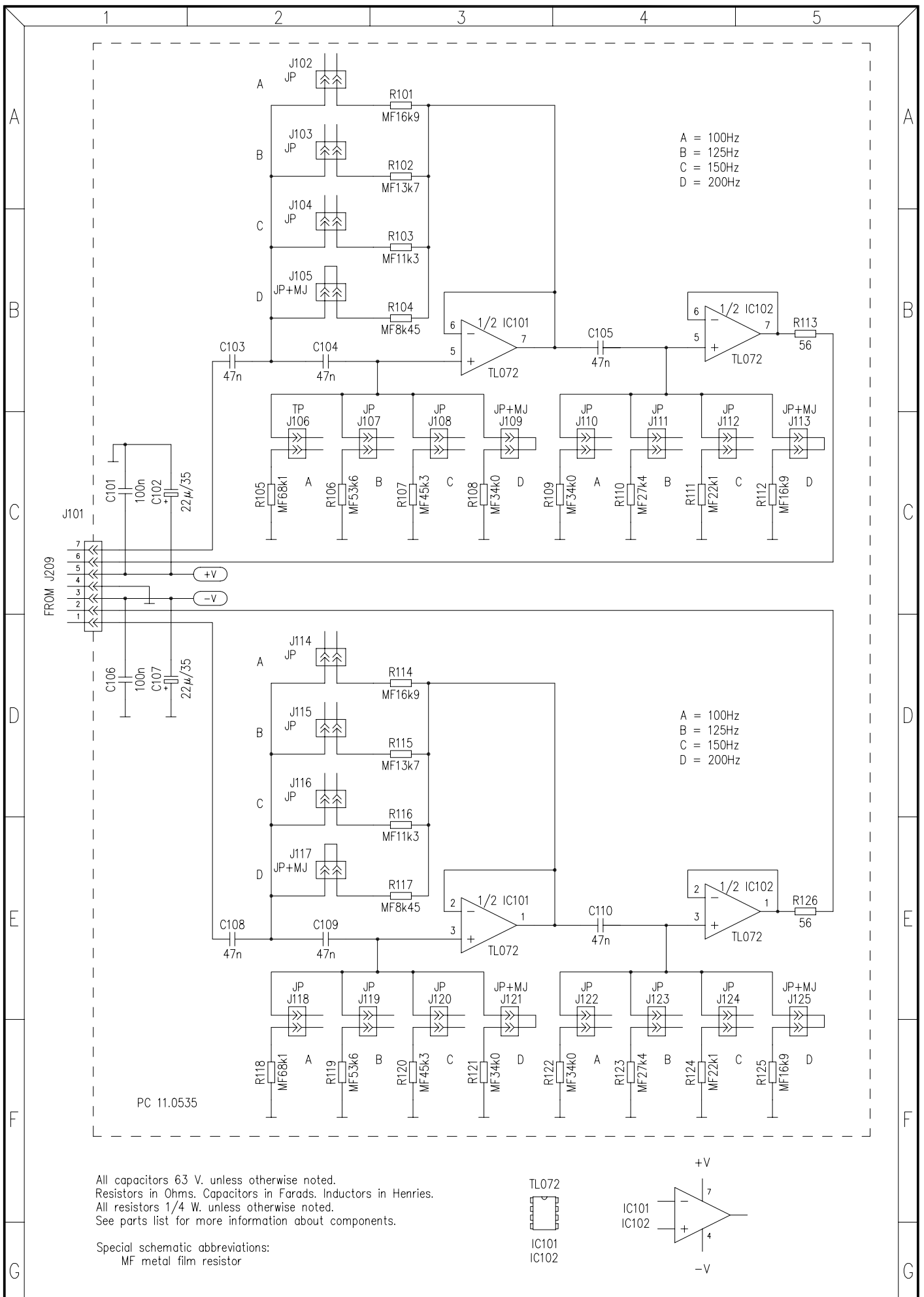

TITLE: <div style="text-align: center;">HIGH PASS FILTER</div>		MODEL: <div style="text-align: center;">FA2-HP</div>		ECLEREO	
DRAWN: J.QUERALT		DATE: 291194		LABORATORIO DE ELECTRO-ACUSTICA BARCELONA ESPAÑA	
CHECKED:		DATE:		REPLACES: 1 OF 1	
		REPLACED BY:		DRW. NO. 10.0270	
				REV.	

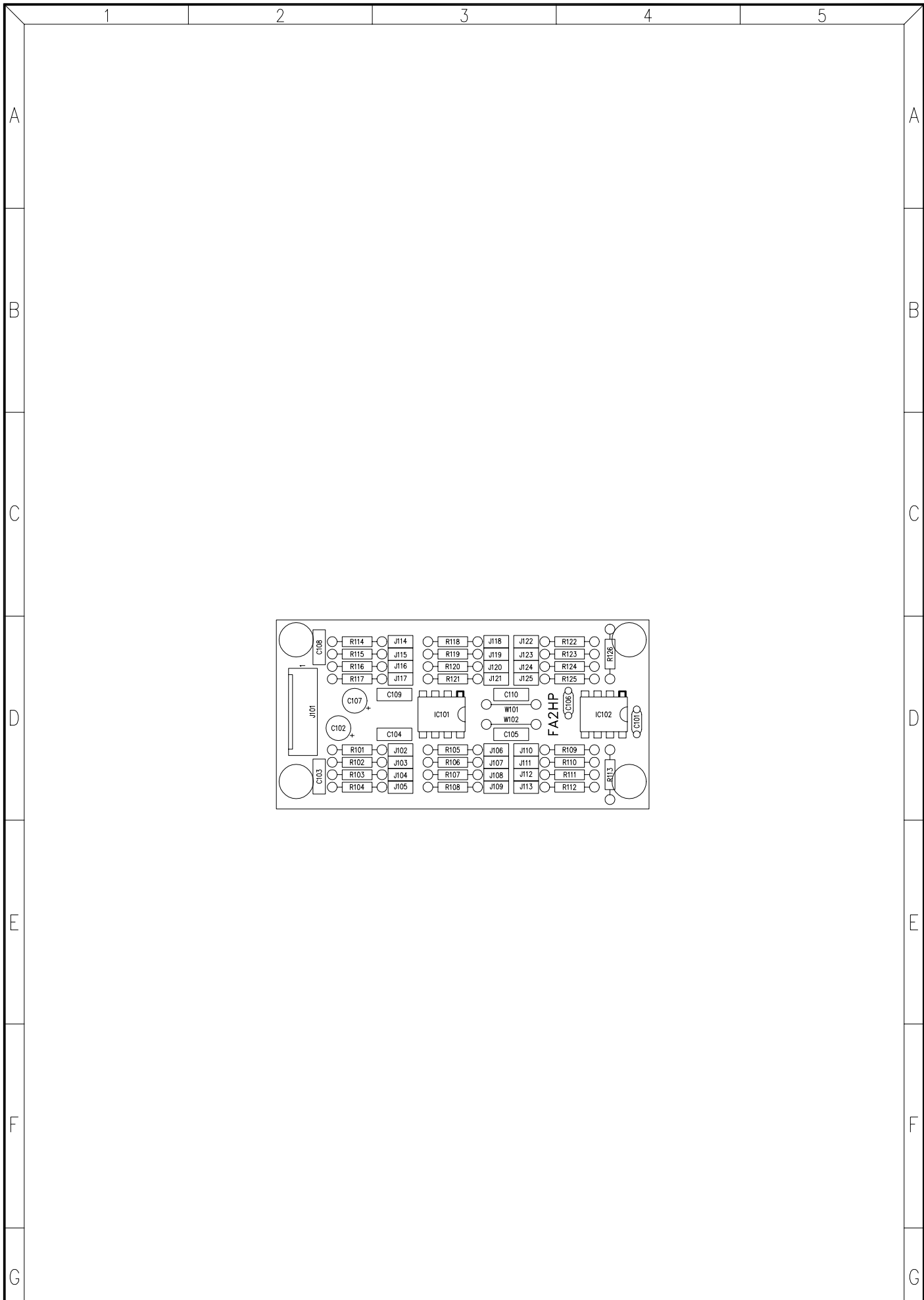

TITLE: HIGH PASS FILTER		MODEL: FA2-HP		 LABORATORIO DE ELECTRO-ACUSTICA BARCELONA ESPAÑA	
		SHEET OF			
DRAWN: AMOROS/QUERALT	DATE: 291194	REPLACES:		DRW. NO.	REV.
CHECKED:	DATE:	REPLACED BY:		33.0084 R/	

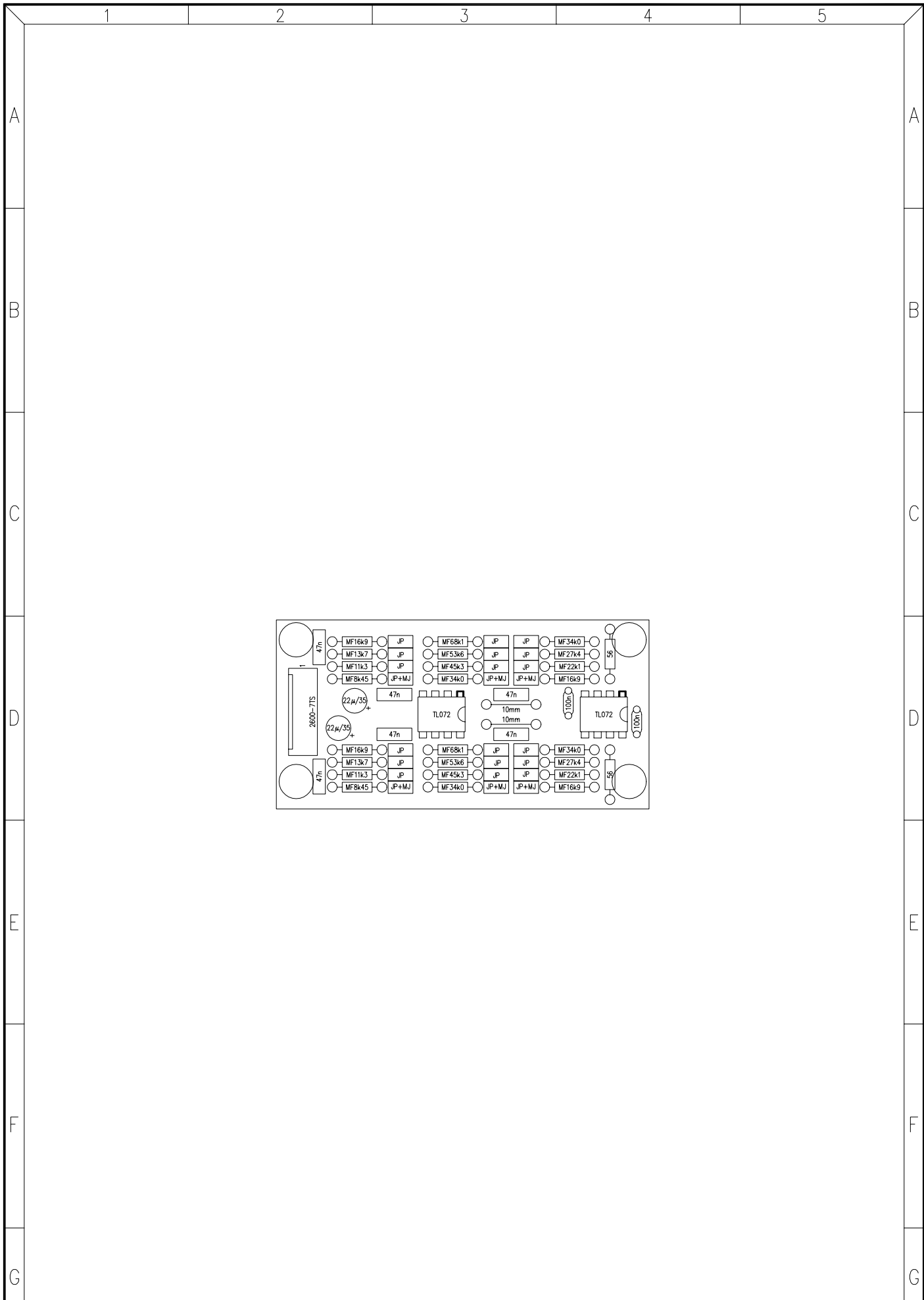

TITLE: HIGH PASS FILTER		MODEL: FA2-HP		 LABORATORIO DE ELECTRO-ACUSTICA BARCELONA ESPAÑA	
		SHEET OF			
DRAWN: AMOROS/QUERALT	DATE: 291194	REPLACES:		DRW. NO.	REV.
CHECKED:	DATE:	REPLACED BY:		33.0084	V/

PARTS LIST:
MODEL: FA2-HP
DATE: 291194

HIGH PASS FILTER
DRW. No 33.0084PL
SHEET 1 OF 2 REPLACES:

REV:
REPLACED BY:

REFERENCE	VALUE
IC101	TL072
IC102	TL072
C101	100n
C102	22 μ /35
C103	47n
C104	47n
C105	47n
C106	100n
C107	22 μ /35
C108	47n
C109	47n
C110	47n
J101	2600-7TS
J102	JP(JUMPER PIN)
J103	JP
J104	JP
J105	JP+MJ
J106	JP
J107	JP
J108	JP
J109	JP+MJ
J110	JP
J111	JP
J112	JP
J113	JP+MJ
J114	JP
J115	JP
J116	JP
J117	JP+MJ
J118	JP
J119	JP
J120	JP
J121	JP+MJ
J122	JP
J123	JP
J124	JP
J125	JP+MJ
R101	MF16k9
R102	MF13k7
R103	MF11k3
R104	MF8k45
R105	MF68k1
R106	MF53k6
R107	MF45k3
R108	MF34k0
R109	MF34k0
R110	MF27k4
R111	MF22k1
R112	MF16k9
R113	56 Ω
R114	MF16k9
R115	MF13k7
R116	MF11k3
R117	MF8k45
R118	MF68k1
R119	MF53k6

PARTS LIST:
MODEL: FA2-HP
DATE: 291194

HIGH PASS FILTER
DRW. No 33.0084PL
SHEET 2 OF 2 REPLACES:

REV:
REPLACED BY:

REFERENCE

VALUE

R120	MF45k3
R121	MF34k0
R122	MF34k0
R123	MF27k4
R124	MF22k1
R125	MF16k9
R126	56Ω
W101	10mm
W102	10mm
PC 11.0535	PRINTED CIRCUIT