

THE hafler P505

PROFESSIONAL POWER AMPLIFIER

INSTALLATION AND OPERATION

CAUTION:
IF THE SPEAKER FUSES BLOW,
SOME DISTORTED SOUND CAN BE
HEARD. THEREFORE IF AMPLIFIER
MALFUNCTIONS, ALWAYS CHECK
FOR BLOWN FUSES FIRST.

LM135

SPECIFICATIONS

Power Rating: 400 watts per channel into 4 ohms at less than 0.04% THD from 20 Hz to 20 kHz with both channels driven.

255 watts per channel into 8 ohms at less than 0.025% THD from 20 Hz to 20 kHz with both channels driven.

800 watts into 8 ohms at less than 0.04% THD from 20 Hz to 20 kHz in monophonic bridged operation.

IM Distortion (SMPTE): Less than 0.007% from 1 watt to 225 watts, each channel, into 8 ohms.

Typical THD at 255 watts into 8 ohms: 1 kHz: 0.002%
10 kHz: 0.007%

Frequency Response into 8 ohms: -3 dB, 2 Hz to 120 kHz at 1 watt.
 ± 0.5 dB, 5 Hz to 40 kHz at 255 watts.

Typical Channel Separation at 1 kHz: 65 dB

Signal to Noise Ratio: Exceeds 100 dB referred to 255 watts into 8 ohms, unweighted.
Exceeds 90 dB referred to 1 watt into 8 ohms, A weighting.

Input Impedance: 47,000 ohms, in parallel with 50K ohms input level control.

Input Sensitivity: 2.35 volts for 255 watts into 8 ohms; 0.14 volt for 1 watt.
2 volts for 400 watts into 4 ohms; 0.08 volt for 1 watt.

Damping Factor: 200 to 1 kHz into 8 ohms; 60 to 10 kHz into 8 ohms.

Rise Time: 10 kHz, 80 volts p/p square wave, 10% to 90%: 2.5 μ s.

Slew Rate: 1 kHz, 120 volts p/p square wave, 40 V/ μ S.

Semiconductor Complement: 27 transistors, 12 power MOSFETs, 33 diodes, 8 zener diodes,
1 integrated circuit, 1 diode bridge.

Power Consumption: 240 VA quiescent; 1200 VA @ rated power into 8 ohms, both channels driven.

Size: 7" high plus 1/4" feet, 19" wide, 13" deep plus 1" for handles.

Net Weight: 48 lbs.

Shipping Weight: 52 lbs.

WARNING: TO PREVENT FIRE OR SHOCK HAZARD, DO NOT EXPOSE THIS EQUIPMENT TO RAIN OR MOISTURE.

CAUTION: For continued protection, replace the power fuse only with the same type and rating as indicated.

INTRODUCTION

The P505 is a high power two channel audio power amplifier designed and constructed for professional sound applications. It can deliver very high power into 4 ohm loads, simultaneously maintaining a level of performance normally associated only with 'state of the art' amplifiers of lesser power capability.

The rated continuous power output from each channel is 400 watts into 4 ohms. The short term continuous power is in excess of 500 watts per channel into 2 ohms. **This is more than enough to disable most loudspeakers if improperly applied.** Moreover, the conservative rating method we use, and the design factors which contribute to its excellent sound and superior low impedance drive capabilities, necessitate a word of caution about its peak power potential. **Peak power outputs can be more than double continuous ratings.** Each channel is capable of delivering more than 20 amps into a short circuit! And, in monophonic applications, the P500 can deliver in excess of 800 watts continuous power into 8 ohms. Such reserves of power must be treated with understanding, as the Hafler Company will not be responsible for misuse, or consequent loudspeaker damage.

Distinctive features of the P505 reflect the focus of this design on the specific needs of the professional sound installer. Ease of installation and setup, through attention to the smallest detail, is coupled with overrated components, and rugged construction to deliver 'workhorse' dependability. The choice of notably rugged design binding posts for load connection allows for a choice of wiring termination, and they are on $\frac{3}{4}$ " centers to facilitate the use of dual banana plugs. The mono-stereo bridging switch is on the back panel, not hidden inside. A choice of input connectors is provided for. Air filters and loudspeaker fuses may be replaced quickly without having to dismount or open the amplifier. The Hafler 'total design' approach minimizes your time and cost of installation and equipment service, and provides a high level of protection to associated equipment and operating personnel.

The P505 incorporates a number of protective devices. Separate power supply fuses for B+ and B- on each channel, individual thermal sensors on each heat sink, a relay to disengage the output if excessive DC offset is detected, a delay to avoid turn-on transients, and accessible output fuses on the back panel to protect the load are in addition to the AC line fuse, which must be located inside to conform to safety codes. Connections and variable controls are located on the back panel, secure from accidental manipulation. The front panel bears only the power switch with its combination pilot lamp and over temperature indicator.

A major factor in the P505's superiority is the choice of power MOSFET devices as the output interface between the signal and the load. These transistors exhibit intrinsic self-regulating characteristics that serve to protect both the amplifier and the associated equipment against damage due to overheating or inadequate current limiting. The benefits over conventional circuitry are obvious — the protective circuitry which is a chief cause of extraneous signals in traditional designs is eliminated, and you have greater reliability from a simpler design.

The P505 retains the time-proven design parameters that have established the Hafler reputation for exceptional amplifier performance: complementary push-pull circuitry, direct coupling beyond the initial input, all silicon discrete devices, minimal use of feedback, conservative specification of all components, and a carefully distilled circuit topology. You can expect the manufactured product to consistently deliver the same high standards of power output, low distortion and low noise normally associated with laboratory prototypes.

Thank you for purchasing this Hafler amplifier. Our Technical Services Department is available to answer any questions at (609) 662-6084. We are here to see that your experience with Hafler products is satisfactory and profitable in every way.

P505 POWER AS A FUNCTION OF IMPEDANCE

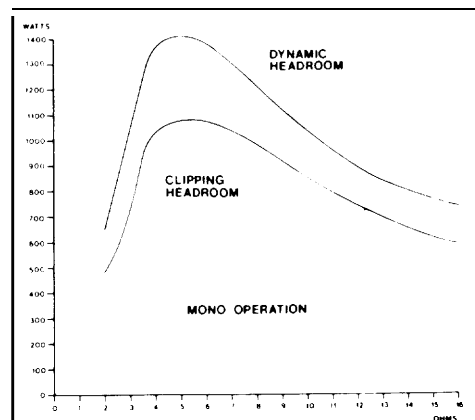
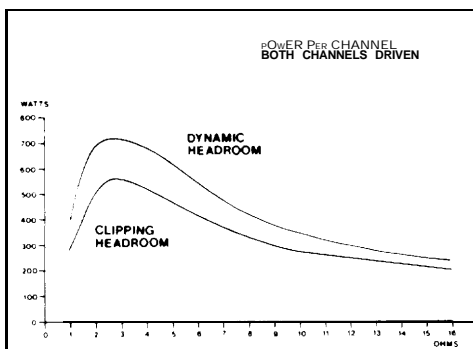

INSTALLATION

Adequate ventilation is a primary consideration when installing any high power amplifier, because of its appreciable heat output. Cool air is drawn in through the foam filters on the sides, and the warm exhaust is to the rear. Make sure this flow is not impeded, and do not allow the system to work in a closed box. The filters must be kept clean - just slip them out, wash them, and squeeze dry. Replacements are available from the Hafler Company, but if you choose to obtain them locally, make sure you use 'open cell' foam for air conditioner filters. Amplifiers supplied for overseas use with line voltages above 200 VAC use a different fan than those intended for 100 - 120 VAC. If conversion to the other line voltage range is indicated, be sure the correct fan is obtained from the factory. See "AC Line Connections for Overseas Use."

The front panel is designed for mounting in a standard EIA 19" wide rack, using four #10-32 screws and countersink washers. It is sufficiently rigid to support the P505 safely. The panel is slightly under the 7" height to allow clearance between adjacent units. The feet may be unscrewed from the bottom to facilitate such installation.

A power transformer of this size will radiate a noticeable hum field, even though Hafler transformers are specially engineered to reduce this effect. If the amplifier is likely to be installed close to equipment which may be sensitive to such a field, such as microphone amplifiers or other high gain audio stages, be sure you have adequate separation.

CONNECTIONS

AC Line

A 3-wire grounded power cord is provided on the P505. It must be connected to a properly grounded (earthed) AC receptacle for your safety. Never break off the ground pin on the plug to avoid obtaining the proper adapter for 2-wire receptacles. Do not use cords which are frayed, or whose plug is damaged. Do not disconnect by pulling on the cord. Grasp the plug itself.

High power output puts heavy demands on the supply wiring. Each P505 requires 15 amperes (at 120 VAC) for proper operation. A separate 20 ampere line is recommended. If extension cables must be used, keep them short, and use #14 gauge or heavier 3-wire cord.

Input

The amplifier is supplied with standard 2-circuit (tip-sleeve or T-S) 'phone' jacks for normal unbalanced input connections. These use single conductor shielded cable (shield connected to the sleeve), or you may choose two wire shielded cable. With two wire cables, and an unbalanced input, the signal, or 'hot' (black) lead connects to the plug tip and the ground (white or red) lead connects to the sleeve. Hum is usually minimized in two wire cable by connecting the shield to the ground wire at one end only.

If very long input signal cables are required, a balanced input is usually advisable, using two wire shielded cable, and adding the Hafler BL500 option, which eliminates the need for hum-sensitive external input transformers. Then the 2-circuit (T-S) phone jacks may be replaced by 3-circuit (tip-ring-sleeve or T-R-S) jacks, wired with the 'low' (white or red) lead to the ring, and the shield to the sleeve. Or, 3-pin 'Cannon XLR' connectors may be installed via the chassis knockout provided.

The XLR connectors are often preferred for either balanced or unbalanced lines because of a locking provision. Because there are two wiring standards, you want to make sure all your equipment is consistent. The IEC International standard connects the shield to pin #1 and the signal ('high' - black wire) to pin #2. On a balanced line, the return ('low' - white or red wire) would go to pin #3. The defacto American standard, which is not as widely used, interchanges the connections to the #2 and #3 pins.

Some applications may require the use of an input transformer, to convert balanced lines to unbalanced connections ahead of the power amplifier. Such transformers are very sensitive to magnetic fields, such as those generated by the power transformer. You may have to install them a fair distance from the P505 to avoid hum pickup.

Output

The red and black binding posts were chosen for heavy duty construction to handle the high currents which may be involved. They are spaced for dual banana plugs, or you can connect bare wire ends through the vertical holes in the shafts, which are visible when the cap is unscrewed. To be certain that no wire strands are unsecured, a tinned end, or a spade lug soldered to the wire is recommended.

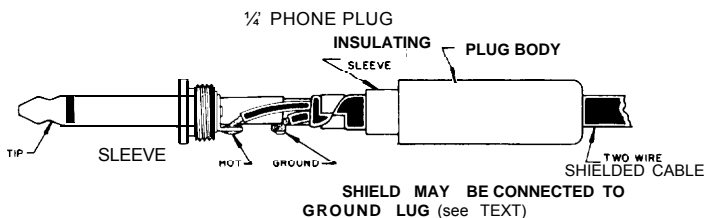

Maintain a consistent polarity with respect to the 'hot' and 'ground' wires to the speakers. Most dual banana plugs have a tab identifying one side, which is customarily made the 'ground' side. In stereo speaker installations it is important to keep consistent phase relationships to preserve low frequency response and stereo 'imaging' perspective. This means that the same wiring 'sense' should be followed when wiring each speaker.

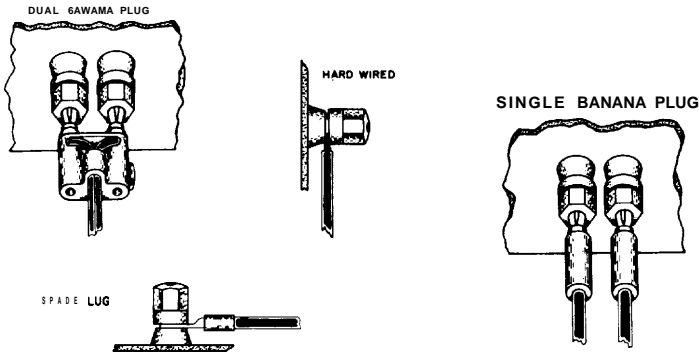

The black output terminals may be connected together (common ground) when accessories utilizing a common ground system, such as headphone junction boxes, are employed. However, the red terminals should **never** be connected together. Thus you should carefully check connections when using a common ground device, to be sure there is no reversal of the ground and high side.

Connecting Cables

The permissible cable length for an unbalanced input is determined by two factors: the cable capacitance per foot, and the output impedance of the signal source, which is a function of the design of the output stage of the source (control center). Cable capacitance is part of the 'load' on the signal source. As the capacitance increases, the effect is that of a progressive filter which rolls off the high frequencies before they reach the power amplifier. The amount of the roll off increases as the output impedance goes up. With most control centers and normal input cables (under 20 feet) the filter effect will be above the audio range. If the output impedance of the source exceeds 500 ohms at 1000 Hz, a high cable capacitance may cause oscillation in the source equipment. Shortening the cable, or choosing a special low capacitance cable type may solve the problem. If very long signal cables are required, converting to a balanced input is the best solution. The Hafler BL500 balanced input option may be installed in the P505, and avoids the need for hum-sensitive input transformers.

The choice of shielded wire for input cables may involve more than just the capacitance per foot. Where resistance to abuse is a factor, the rubber-clad cables with woven shielding outperform vinyl coverings. The vinyl insulation is usually supplied with a foil shield which can be easily torn, so plugs

must be wired with great care. If permanent wiring involves 'fishing' cables through conduits, the vinyl cable is easier to use because it has less surface resistance, but the foil shield is susceptible to splitting with undue stress.

Some thought should also be given to selecting the output cables. When high power is demanded from the amplifier, the impedance of the output cables becomes part of the loudspeaker load. The desirably high damping factor of Hafler amplifiers, which is an index of the amplifier's ability to control the speaker, is reduced by excessive cable impedance. Even more, long runs of inadequate wiring waste power. The following chart illustrates typical power dissipation with a 4 ohm load. The lowest gauge, or heaviest practical wire size is always preferred. When very long output cables are required, the use of balanced 70 volt lines is recommended. The Hafler LX250 transformer can provide a 70.7 volt output from one channel of the P505. The rated available power per channel is the equivalent of its 8 ohm output of 255 watts. Predrilled holes in the amplifier's cover can accommodate two transformers. The output voltage of a P505 operated in the monophonic bridged mode is sufficient to drive a 70 volt line directly without the need for a transformer.

Wire Gauge (A.W.G.)	Power Loss in Watts @ 4 ohms	
	25' cable	100' cable
6	1.8	6.9
10	4.4	17.3
14	11.1	41.3
18	26.8	91.2

Monophonic Operation (Bridged Mode)

When very high power is desired, the P505 can be switched to a single channel amplifier, capable of delivering more than 800 watts into an 8 ohm load. For this, the Stereo-Mono slide switch is moved to Mono, and an input signal is applied to the Left input jack only. The two output leads are connected only to the Red terminals, and no connections are made to the black terminals. The output must be 'floating' - that is, neither side can be grounded, as both are 'hot' with respect to chassis ground. The red terminals are identified (+) and (-) simply for phasing reference. In this mode, the P505 can drive a 70 volt distribution line directly. Sensitivity is adjusted by the Left input level control.

OPERATION

Press the power switch to the right to turn the amplifier on. Operation will be signalled by the illuminated lamp in the switch. If it does not light, the most likely cause is a blown AC line fuse. That is the single fuse close to the switch inside the chassis. However, since that fuse is a 15 ampere slo-blo (for 120 VAC lines) and a common branch circuit is also rated at 15 amperes, check the main fuse or breaker panel first.

Standard practice is to turn power amplifiers on last, and switch them off first, in the electronics chain. This minimizes annoying noise bursts, or the likelihood of damage to the speakers from turn-on transients generated by source equipment. The P505 provides built-in protection from such transients by incorporating a delay of 3 seconds at turn-on, before the relay connects the speakers. Some source equipment may not be silent within 3 seconds, so if you wish to extend the P505's delay time, contact the Hafler Technical Service Department.

The relay serves another purpose - to protect the speakers in the event an unsafe DC voltage appears at the output. Then the speakers will be disconnected until the voltage drops to a safe level. Very high levels of very low frequency energy can sometimes imitate DC at the output, and might activate the relay inappropriately. If this is the case, the level of DC protection provided by the relay can be changed. Contact the factory for assistance.

If the pilot lamp should ever blink (2-3 times a second) this signifies that a protective thermal breaker has shut down the amplifier because of excessive heat sink temperature. The fan will continue to operate at its highest speed, and as soon as the heat sink temperature has declined, the amplifier will automatically return to normal operation. If such a shut down recurs, you should check for inadequate ventilation, or an excessive input signal, an extremely low load impedance, or an input with dangerous signal content (such as oscillation). Failing any such indication, the fan or the amplifier may require service. Because of the effective fan cooling, any normal signal will not cause the amplifier to overheat.

Testing the amplifier to its limits with laboratory signals may exceed the capacity of a 15 ampere circuit, and may require higher fuse ratings under severe load conditions. If a back panel speaker fuse blows, some distorted sound will be heard. Always check those fuses first. When performing tests at high power levels, line voltage losses need to be compensated for, or taken into consideration. Likewise, an inadequately sized line may suffer voltage drops which adversely effect other electronics when high power demands occur.

Air filters

The air intake filters should be kept clean to allow maximum cooling of the amplifier. The protection they provide against dirt maintains efficient amplifier operation and extends reliability, so they should not be discarded. They are easily slipped out for washing in a mild detergent solution, rinsed, and squeezed dry. They are made of a flame retardant material having a specific porosity, so exact replacement is best. They may be ordered from the Hafler Company as part #AF002.

Back Panel Controls

An input level control adjusts the sensitivity of each channel. They are usually left at full clockwise rotation, for maximum sensitivity and best signal to noise ratio. Then 2 volts will drive each channel to full output (4 ohm load). These controls have a 'B' taper, with a reduction of 6 dB at 50% rotation.

The 'Stereo-Mono' switch selects either normal two channel operation, or a combined utilization of both channels, which sends a single input signal through the entire amplifier, and provides a monophonic 'bridged' output across the channels, at very high power. In the Mono mode, only the Left input and the Left level control are operative, and the load is connected to the two Red outputs only. Never make any connections to the black output terminals in the mono mode. Note that the amplifier's specified power output capability in the mono mode is at a higher load impedance than for stereo operation.

The 'Float-Chassis' switch determines the ground (earth) path of the signal ground. It is normally set in the 'Chassis' position, where it is tied directly to the chassis ground. In some instances, such as where several components are mounted in a rack, 'ground loops' may introduce hum or increased noise. Moving this switch to the 'Float' position may improve this condition. In this position the signal grounds are referred to the chassis through a 0.01 mfd capacitor.

Switch settings may be safely changed while the power is on.

Speaker Fuses

The two fuse holders on the back panel protect the speaker load from excessive drive signals. They are in the feedback loop from the output stage. When one of these 'blows', a distorted signal will be heard at greatly reduced level. It is to your advantage to choose a fuse size appropriate to your speakers, since the P505 can deliver more power than most speakers can safely tolerate. The David Hafler Company cannot be responsible for damage to the loudspeakers or the amplifier resulting from improper fusing.

If the manufacturer of your speakers recommends a fuse rating, you should install that value in the back panel holders. When purchasing replacements, do not use the 'slo-blo' type. Type AGC, or 3AG series are suggested. The P505 is shipped with 10 ampere fuses installed. This is the maximum value, and will provide no speaker protection, allowing full power testing. A pair of spare 5 amp fuses is supplied for some protection at lower power.

There is a distinct difference between fuse ratings for continuous power and for intermittent 'peak power' needs. A 2 ampere fuse with an 8 ohm load permits continuous power up to 32 watts, but will sustain intermittent musical peaks to the maximum power output. A 3 ampere fuse permits 72 watts continuously into an 8 ohm load, or a steady 36 watts into a 4 ohm load. A 5 ampere fuse allows 200 watts into 8 ohms, or 100 watts into 4 ohms. Thus even a 5 ampere fuse provides very little speaker protection.

When the amplifier is operated in Mono, both speaker fuses are in the circuit. If only one is blown, it is advisable to replace the other as well, since it has also been stressed to the breaking point.

AC LINE CONNECTIONS FOR OVERSEAS USE

The power transformer supplied in P505 amplifiers sold in the USA is intended for 120 volt, 60 Hz operation only. For use in other countries, a multi-voltage transformer is supplied in Export versions, available at higher cost. It has dual tapped primary windings which can be connected in series or parallel combinations for 100, 120, 200, 220 or 240 volts, 50 or 60 Hz power lines. The Export version includes an additional terminal strip to terminate the extra transformer leads. In units supplied for 200 volt and higher AC lines, the line fuse is a 7 ampere slo-blo type, and a different fan is installed, along with different fan controlling power resistors, which are mounted on the underside of the audio module.

The diagrams below show schematically and pictorially the alternative wiring for different supply voltages.

100v.

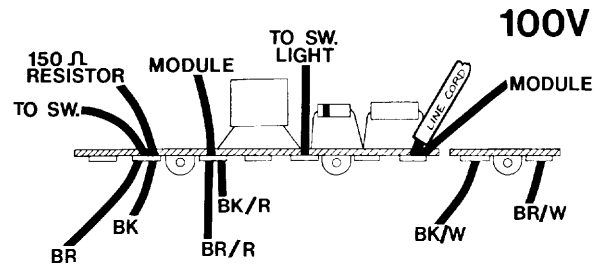
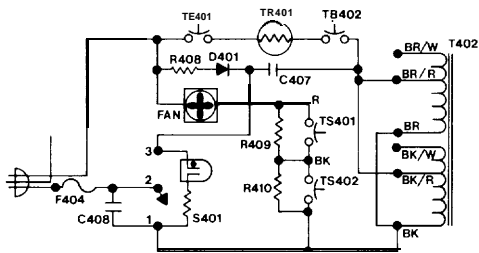

120v.

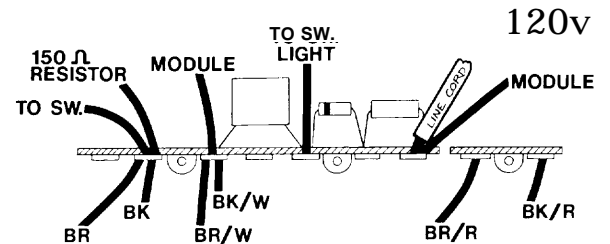
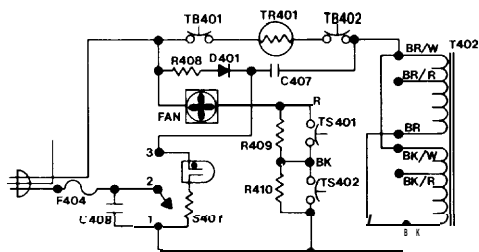

200V.

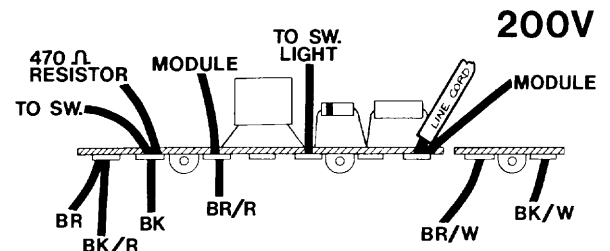
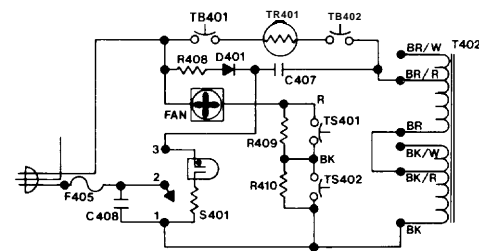

220V.

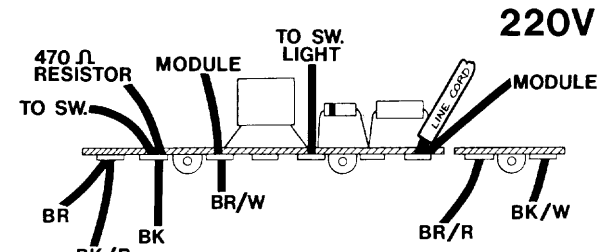
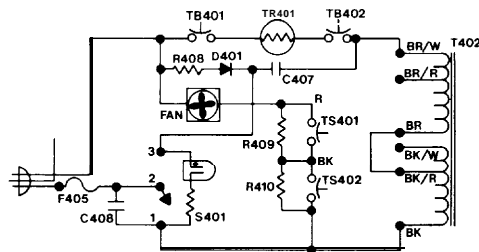

240V.

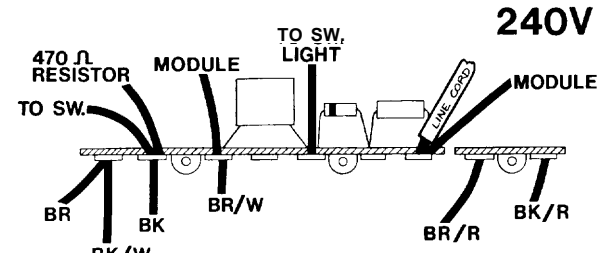
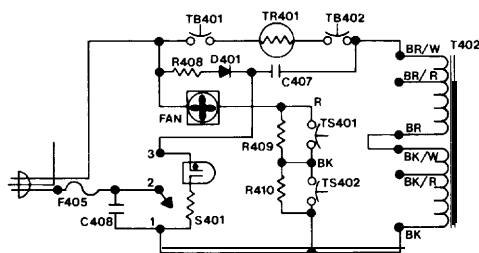

TROUBLE SHOOTING HINTS

Check the speaker fuses first when there is little or no sound. A blown fuse will pass a low level distorted signal. If the pilot lamp is steady, excessive DC at the output may be holding the relay open. If the lamp blinks, then the thermal protective circuitry has shut down the amplifier.

Always check external factors such as cables and signal sources before dismantling the P505. Once the cover is removed, do not attempt to move the amplifier by the front panel handles! Check the internal fuses. The line fuse is near the power switch. The two dual fuse holders monitor the B+ and B- 'rail' voltage. Failure of any of these indicates a circuit problem, unless the amplifier was undergoing very high power tests into a low impedance load, where the fuse sizes may need to be increased.

If the amplifier requires factory service, and the power transformer output appears normal when its secondary leads are disconnected from the diode bridge, the transformer can be removed, and the rest of the amplifier returned for service. This greatly reduces the cost of shipping, and the risk of damage in transit. If you have isolated the fault to the audio module, you may prefer to disconnect it, and return it as a unit (fan, heat sinks, circuit boards). Four screws secure it to the chassis. Be sure you tag every wire as you unsolder it. When packing it, wrap it first to prevent particles of packing material from becoming trapped, and provide plenty of cushioning.

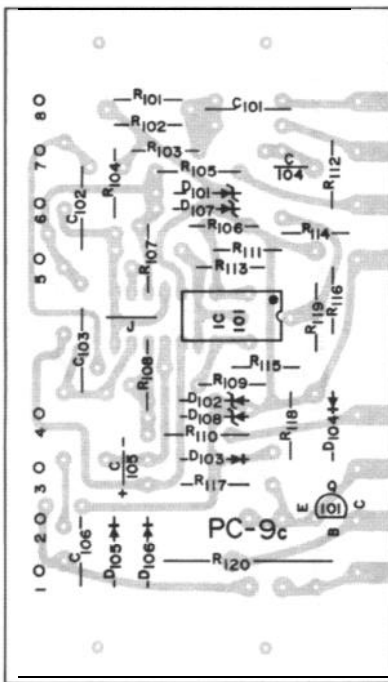

PC-9 COMPONENTS

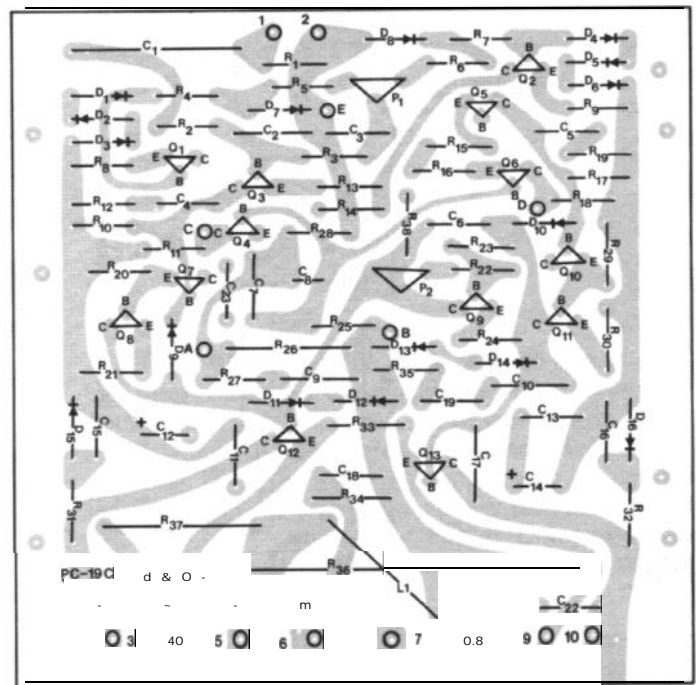

PC-19 COMPONENTS

SQUARE WAVE RESPONSE WITH A REACTIVE LOAD

120 volts peak to peak into 1 ohm in series with 10 mH.

100 Hz

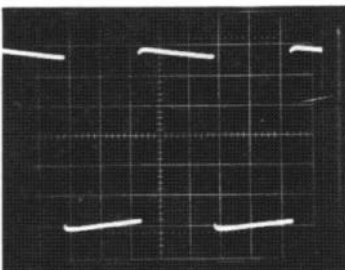

120 volts peak to peak into 8 ohm resistor in parallel with 1 mfd.

1 kHz

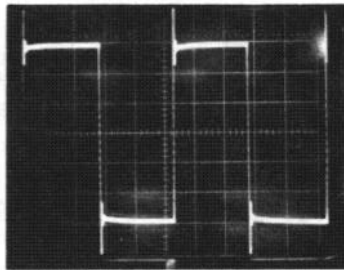

10 kHz

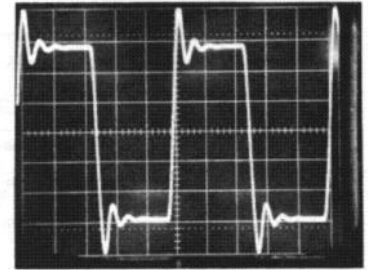

CIRCUIT DESCRIPTION

Amplifier stages are fully direct coupled (DC coupling). with a dual differential pair for the input, and a fully complementary MOSFET output stage. Transistors Q3, Q4, Q5 and Q6 form the differential input, while Q1 and Q2 are constant current sources for the input pair. Potentiometer P1 adjusts the output offset voltage.

Transistors Q7, Q8, Q10 and Q11 form the second gain stage, and are the 'predrivers' for the output stage drivers Q12 and Q13.

An adjustable voltage reference is formed by transistor Q9 and potentiometer P2. The signal 'sees' the bases of transistors Q12 and Q13 tied together. P2 adjusts the voltage to bias the amplifier for Class AB operation, and therefore determines the quiescent (idle) current in the driver and output stages. Thermal stability is assured by the positive temperature coefficient of the MOSFETs.

The output stages are also fully complementary. Q401, Q402 and Q403 are N channel MOSFETs connected in parallel for the positive half of the signal. Q404, Q405 and Q406 are P channel MOSFETs for the negative half.

There is none of the usual volt-amp limiting in this design. Diodes D11, D12, D13 and D14 prevent the gates of the MOSFETs from being overdriven in the event of excessive signal levels. The output current is limited by the B+ and B- fuses and the speaker fuses.

A protective relay circuit has a j-section low pass filter which prevents signals above 10 Hz from triggering the relay. This circuit allows direct current to pass to IC101, which senses any offset above 3.5 volts and then opens the relay to protect the load. R106 and R107 form the reference for the positive offset detector portion of IC101. R108 and R109 act for the negative detector. The charging time of C104 is the delay time at turn on. D106 and C105 produce a rapid discharge supply that opens the relay instantly when the amplifier is turned off.

An overload protection system includes thermal breakers on the heat sinks which will turn off the amplifier if overheating occurs, and thermal sensors which will bypass fan-limiting resistors as the temperature rises, increasing the fan speed. A current inrush limiter TR401 is located in the AC line input.

FUNCTIONAL BLOCK DIAGRAM

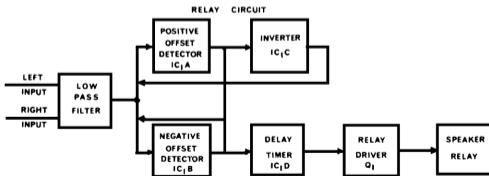
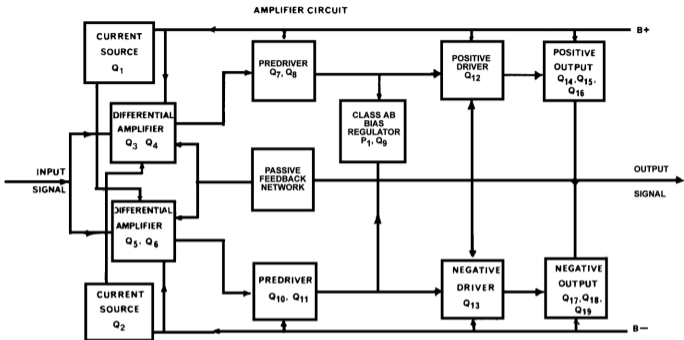

COMPONENT VALUES

All resistors are 1/4 watt 5% carbon film unless otherwise noted.

All capacitors are 100 volt minimum unless otherwise noted.

		Part No.		Part No.		Part No.
R1	470,000 ohms	RC044	C1	2 mfd, 50V, Film	CP115	
R2	1,800 ohms	RC023	C2	330 pF, Film	CP134	
R3	47,000 ohms	RC043	C3	.01 mfd, Film	CP135	
R4	47,000 ohms	RC043	C4	.001 mfd, Film	CP136	
R5	560 ohms	RC045	C5	.001 mfd, Film	CP136	
R6	560 ohms	RC045	C6	.1 mfd, Film	CC125	
R7	47,000 ohms	RC043	C7	.1 mfd, Film	CC125	
R8	560 ohms	RC045	C8	470 mfd, 6.3V, non-polar Electrolytic	CN113	
R9	560 ohms	RC045	C9	150 pF, Film	CP133	
R10	1,800 ohms	RC023	C10	330 pF, Film	CP134	
R11	1,800 ohms	RC023	C11	.01 mfd, Film	CP135	
R12	270 ohms	RC029	C12	100 mfd, 100V, Electrolytic	CL122	
R13	47 ohms	RC039	C13	.01 mfd, Film	CP135	
R14	47 ohms	RC039	C14	100 mfd, 100V, Electrolytic	CL122	
R15	47 ohms	RC039	C15	.01 mfd, Film	CP135	
R16	47 ohms	RC039	C16	.01 mfd, Film	CP135	
R17	1,800 ohms	RC023	C17	150 pF, Film	CP133	
R18	1,800 ohms	RC023	C18	.01 mfd, Film	CP135	
R19	270 ohms	RC029	C19	.01 mfd, Film	CP135	
R20	1,800 ohms	RC023	C20	.1 mfd, Film	CC125	
R21	82 ohms	RC053	C21	.1 mfd, Film	CC125	
R22	560 ohms	RC045	C22	.1 mfd, Film	CC125	
R23	470 ohms	RC041	C23	.001 mfd, Film	CP136	
R24	10 ohms	RC013	C101	.39 mfd, Film	CE117	
R25	33,000 ohms	RC036	C102	.39 mfd, Film	CE117	
R26	3,300 ohms, 1w, metal film	RZ013	C103	.39 mfd, Film	CE117	
R27	1,000 ohms, metal film	RM021	C104	1 mfd, 25V, Non-polar Electrolytic	CN114	
R28	150 ohms, metal film	RM013	C105	22 mfd, 100V, Electrolytic	CL125	
R29	1,800 ohms	RC023	C106	.01 mfd, 1000V, Disc	CZ112	
R30	82 ohms	RC053	C401	680 pF, Mica	CM121	
R31	47 ohms, carbon comp.	RZ011	C402	.1 mfd, Film	CE115	
R32	47 ohms, carbon comp.	RZ011	C403	.1 mfd, Film	CE115	
R33	220 ohms, 1/2 w	RD114	C404	20,000 mfd, 100V, Electrolytic	CL123	
R34	2,200 ohms, 1/2 w	RD115	C405	20,000 mfd, 100V, Electrolytic	CL123	
R35	10 ohms	RC013	C406	.01 mfd, 1000V, Disc	CZ112	
R36	1 ohm, 10 w	RW012	C407	.39 mfd, Film	CE117	
R37	10 ohms, 5 w	RW013	C408	.005 mfd, 1000V, Disc	CZ113	
R38	28,000 ohms, metal film	RM053	C409	.01 mfd, 1000V, Disc	CZ112	
R101	100,000 ohms	RC017	D1-D8	1N4148 Diode	QD116	
R102	120,000 ohms	RC019	D9	FDH-400 Diode	QD121	
R103	150,000 ohms	RC021	D10	FDH-400 Diode	QD121	
R104	150,000 ohms	RC021	D11	1N4148 Diode	QD116	
R105	27,000 ohms, 1/2 w	RD122	D12	1N5240B 10V Zener Diode	QD111	
R106	22,000 ohms	RC026	D13	1N5240B 10V Zener Diode	QD111	
R107	3,900 ohms	RC037	D14	1N4148 Diode	QD116	
R108	3,900 ohms	RC037	D15	1N4003 Diode	QD115	
R109	22,000 ohms	RC026	D16	1N4003 Diode	QD115	
R110	27,000 ohms, 1/2 w	RD122	D101	1N5240B 10V Zener Diode	QD111	
R111	10 megohms	RC018	D102	1N5240B 10V Zener Diode	QD111	
R112	4,700 ohms	RC042	D103	1N4148 Diode	QD116	
R113	10 megohms	RC018	D104	1N4148 Diode	QD116	
R114	1 megohms	RC047	D105	1N4003 Diode	QD115	
R115	10,000 ohms	RC016	D106	1N4003 Diode	QD115	
R116	100,000 ohms	RC017	D107	1N5240B 10V Zener Diode	QD111	
R117	150,000 ohms	RC021	D108	1N5240B 10V Zener Diode	QD111	
R118	10 megohms	RC018	D401	1N4003 Diode	QD115	
R119	22,000 ohms	RC026	Q1	2N5401	QP122	
R120	1,500 ohms, 2 w	RZ015	Q2	2N5550	QN128	
R401	470 ohms, 1/2 w	RD117	Q3	2N5550	QN128	
R402	470 ohms, 1/2 w	RD117	Q4	2N5550	QN128	
R403	470 ohms, 1/2 w	RD117	Q5	2N5401	QP122	
R404	220 ohms, 1/2 w	RD114	Q6	2N5401	QP122	
R405	220 ohms, 1/2 w	RD114	Q7	2N5401	QP122	
R406	220 ohms, 1/2 w	RD114	Q8	2N5415	QP123	
R407	3000 ohms, 1 w	RZ017	Q9	NP2222A	QN124	
R408	1 megohms, 1/2 w	RD113	Q10	2N5550	QN128	
R409	150 ohms, 20 w	RW016	Q11	2N3440	QN125	
R410	150 ohms, 20 w	RW016	Q12	2N3440	QN125	
R411	470 ohms, 20 w	RW025	Q13	2N5415	QP123	
R412	470 ohms, 20 w	RW025	Q101	2N5550	QN128	
DB401	Diode Bridge	QD117	Q401	2SK176	QN113	
F401	Fuse, 5A, 3AG (value optional)	SF012	Q402	2SK176	QN113	
F402	Fuse, 10A, GLH	SF013	Q403	2SK176	QN113	
F403	Fuse, 10A, GLH	SF013	Q404	2SJ56	QP113	
F404	Fuse, 15A Slo-Blo MDA	SF014	Q405	2SJ56	QP113	
			Q406	2SJ56	QP113	

IC40 1	LM339N	QBI 15	s402	DPDT slide switch	SZI22
LI	Inductor, 1 .4uH	TAI 12	S403	DPDT slide switch	SZI22
PI	1000 ohms trimpot	RP01 1	TR40 1	Thermal breaker	SF024
P2	1000 ohms trimpot	RP01 1	TR402	Thermal breaker	SF024
P401	50.000 ohms. level control	RF036	TR40 1	Inrush limiter	RZO16
T40 1	Power Transformer	TAI 16	TS40 1	Thermal sensor	SF025
T402	Power Transformer multi-voltage	TAI 17	TS402	Thermal sensor	SF025
RY401	DPDT relay	SZI 13		Fan, 120 volt	AAI 14
S40 1	Power switch	SLIII		Fan, 200-240 volt alternate	AA129

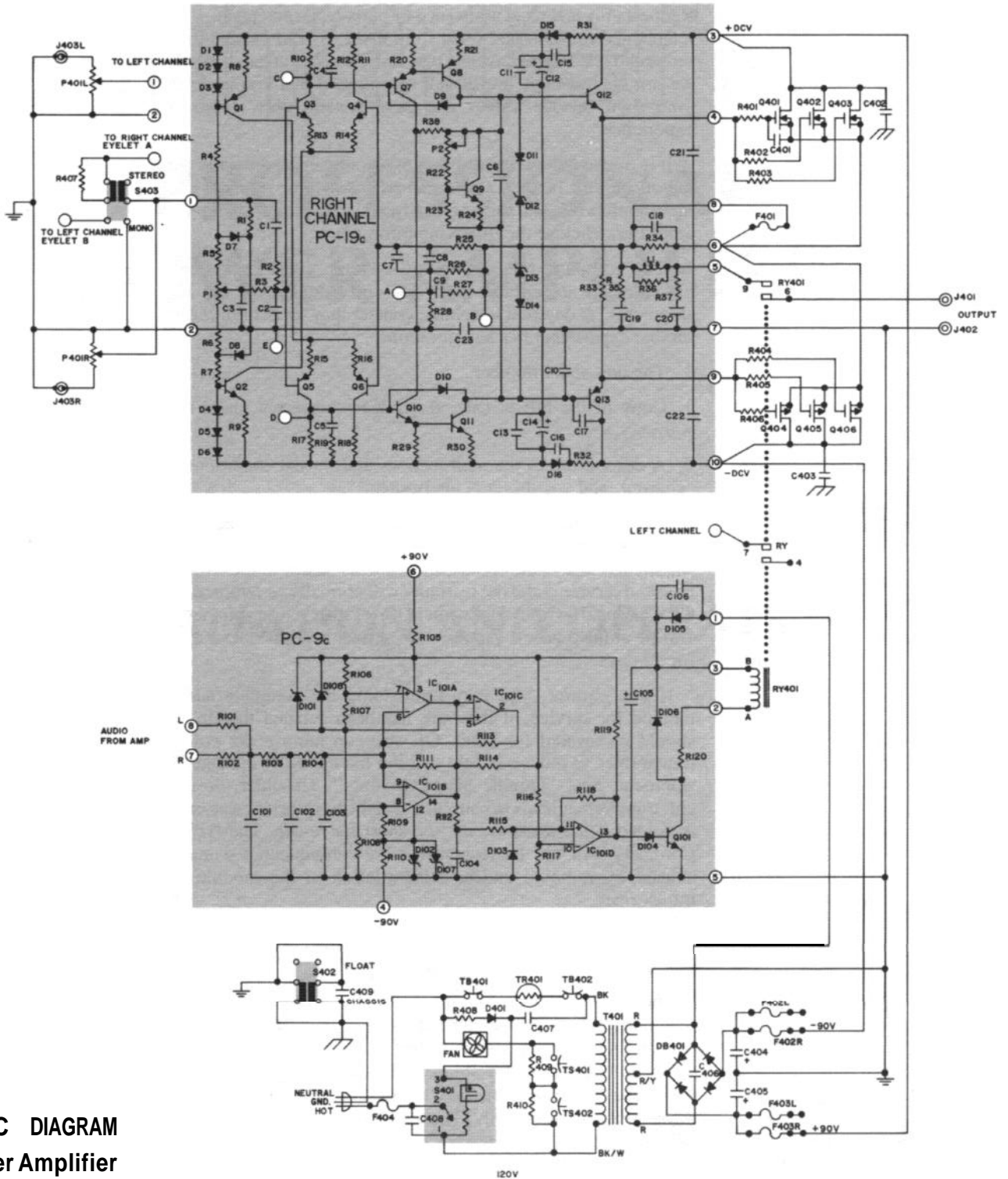

SCHEMATIC DIAGRAM
P505 Power Amplifier

SERVICE POLICY AND LIMITED WARRANTY

The PS0.5 Power Amplifier has been carefully engineered to provide many years of trouble-free service. Every unit is tested before and after a 24 hour 'burn-in' under load, ensuring that any marginal component or operating condition is corrected, and that all operating parameters are stabilized before the unit is released for shipment.

If a problem arises, we urge you to take advantage of the factory service facilities. Many of the components in the P505 are not readily obtainable in the field, and performance is likely to suffer by the use of 'similar type' substitutions. Priority Service is provided for all Hafler Professional products. Requests for technical assistance or parts replacements may be telephoned to (609) 662-6084 from 8AM to 4PM eastern time on weekdays. Please have the unit serial number at hand. While we are glad to help, we do not recommend that you perform your own service unless you have considerable technical experience.

It is the owner's responsibility to ship the unit prepaid to the factory service facility. Collect shipments will be refused. Use the complete original carton and all packing materials to ship the amplifier. Enclose the following information:

1. The complete return shipping address. (Post Office box numbers are acceptable only for correspondence, not for shipment). A daytime telephone contact may be helpful if our service department has any questions.
2. The unit serial number.
3. copy of the bill of sale, if service is expected under the warranty.
4. A description of the malfunction, under what conditions it occurred, and whether it is intermittent.

You are responsible for proper packing. Insure it for the retail value. United Parcel Service is suggested for domestic shipments, and is the usual carrier for its return. Units which required service under the warranty will normally be returned by UPS prepaid, within continental USA. Other return shipments will be at the owner's expense. All service work is guaranteed for 90 days.

If you choose, you may return only the complete audio module for service, if the fault has been isolated therein. It should be insured for \$400. Or, you can remove the power transformer to reduce weight and the likelihood of damage in shipment. See "Trouble Shooting Hints". Unsolder, do not cut, transformer leads in particular, for the transformer warranty is voided if the leads are cut too short for re-use. The Hafler Company will not be responsible for consequential damage caused by removal and/or reinstallation of the module or transformer.

WARRANTY

The P505 is warranted for three years from the purchase date, including parts, labor and normal return shipping costs from the service facility to the owner, within the continental USA. The owner is responsible for shipment to the service facility, and must submit a copy of the dated bill of sale. Warranties apply to the original purchaser only. The warranty is void if the P505 has been modified without factory authorization, or if it has been electrically or physically abused, or if it has been used for some purpose for which it was neither designed nor intended.

This warranty gives you specific legal rights. You may also have other rights which vary from state to state.