

REVISIONS			
REV.	DESCRIPTION	DATE	APPROVED
A	PR 500	04-APR-02	R. B. H.
B	EC 2778	29-APR-02	R. B. H.
C	EC 2802	27-JUN-02	R. B. H.
D	EC 2851	10-SEP-02	R. B. H.

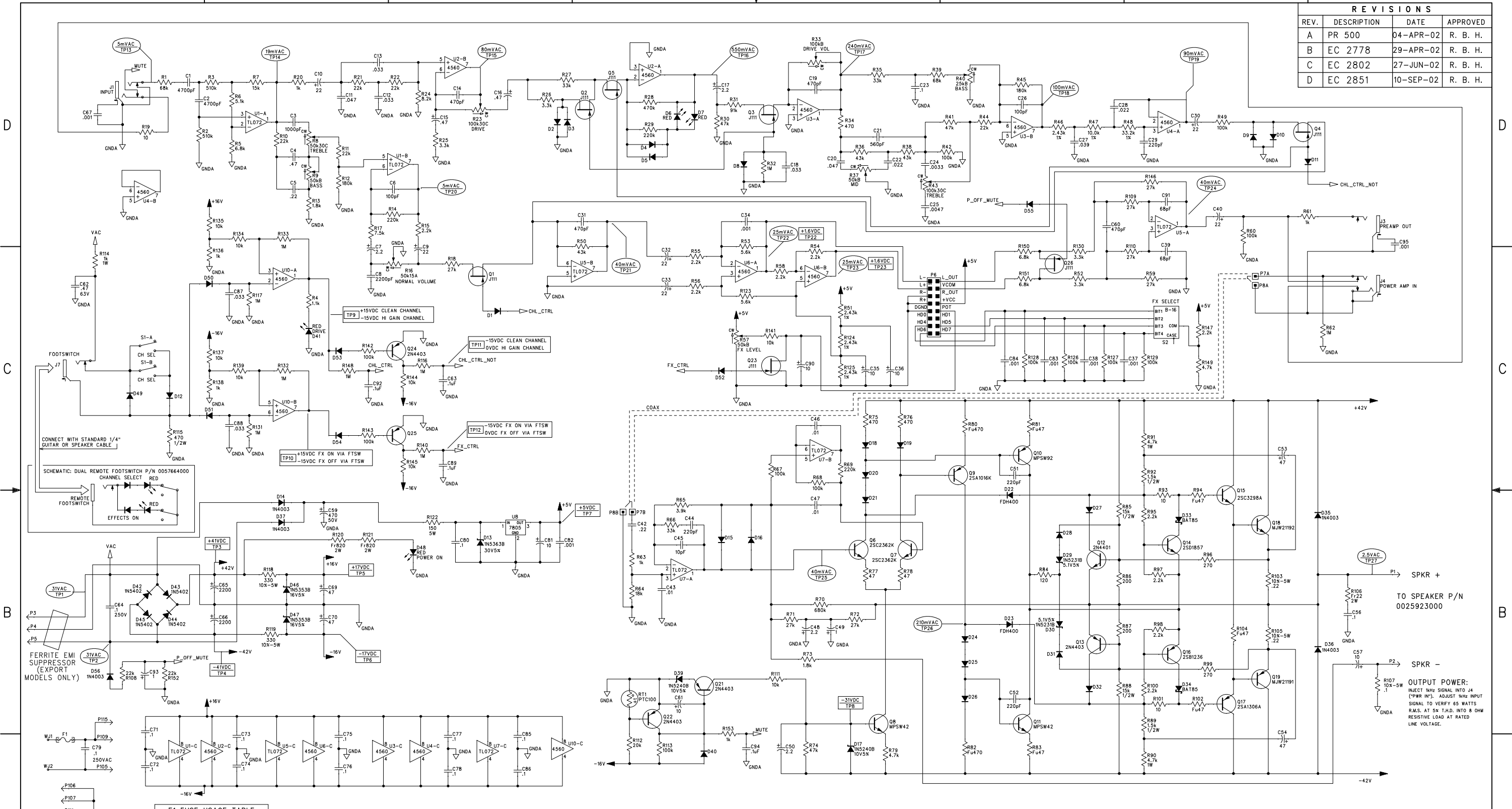

F1 FUSE USAGE TABLE	
100V - 120V	220V - 230V
F2A (250V)	F1A (250V)
AUSTRALIA 240V ONLY	
T1A (250V)	

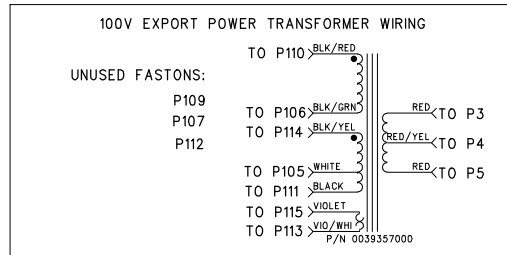
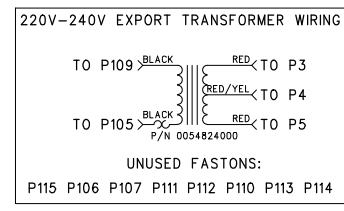
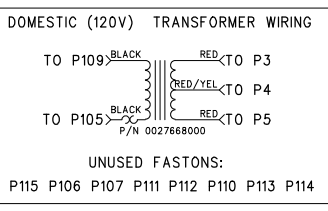
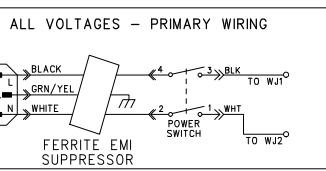

ALL FASTONS ARE 0.250" EXCEPT P105, P111-112, P115 WHICH ARE 0.187"

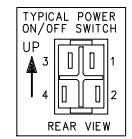

- LAST REFERENCE DESIGNATOR: C95, D56, F1, J7, Q26, R153, R11, S2, U10, P115
 - AC AND DC VOLTAGES ARE READ TO GROUND WITH A DVM UNDER THE FOLLOWING CONDITIONS:
UNIT AT RATED LINE VOLTAGE
8 OHM RESISTIVE LOAD CONNECTED TO P1/P2
NO FOOTSWITCH CONNECTED
CH SEL SWITCH PUSHED IN (RED LED ON)
FX LEVEL CONTROL AT FULL CCW, DRIVE CONTROL AT "3"
ALL OTHER CONTROLS AT "5 1/2"
JACK INSERTED AT J1
NO INPUT SIGNAL (TP1-12)
ADDITIONAL CONDITIONS (TP13-27):
5W 14Hz SINEWAVE INPUT TO J1
 - THIS SCHEMATIC IS FOR PCB FABRICATION P/N 0057424000 AND PCB ASSEMBLY P/N 0057423000.
 - ALL POLARIZED CAPACITORS IN Uf; 20%; 50V MINIMUM.
 - ALL UNPOLARIZED CAPACITORS IN uF; 10% OR BETTER; 50V MINIMUM. (POWER SUPPLY BYPASS CAPACITORS ARE 20%).
 - ALL RESISTORS IN OHMS, 5%; 1/4W.
- NOTES: (UNLESS OTHERWISE NOTED)

THIS DOCUMENT CONTAINS INFORMATION OF A PROPRIETARY NATURE TO FENDER MUSICAL INSTRUMENTS AND IS SUBMITTED TO YOU IN CONFIDENCE AND SHALL NOT BE DISCLOSED OR TRANSMITTED TO OTHERS WITHOUT AUTHORIZATION FROM FENDER MUSICAL INSTRUMENTS.

Fender MUSICAL INSTRUMENTS
Corona, CA USA

CHECKED BY: _____
DATE: _____

APPROVED BY: _____
DATE: _____

DRAWN: R. HAACK ENGR: R. HAACK
DATABASE FILE: Z500S.SCH

TITLE: SERVICE DIAGRAM, COMBINED (schematic)
PRINCETON 65 DSP

SIZE: **D** DRAWING NUMBER: **0057419000** REV: **D**

RELEASE DATE: 04-APR-02 SHEET: 1 OF 2

8 7 6 5 4 3 2 1

REVISIONS			
REV.	DESCRIPTION	DATE	APPROVED
A	PR500	04-APR-02	R B H
B	EC2778	29-APR-02	R B H
C	EC2802	27-JUN-02	R B H
D	EC2851	10-SEP-02	R B H

D
C
B
A

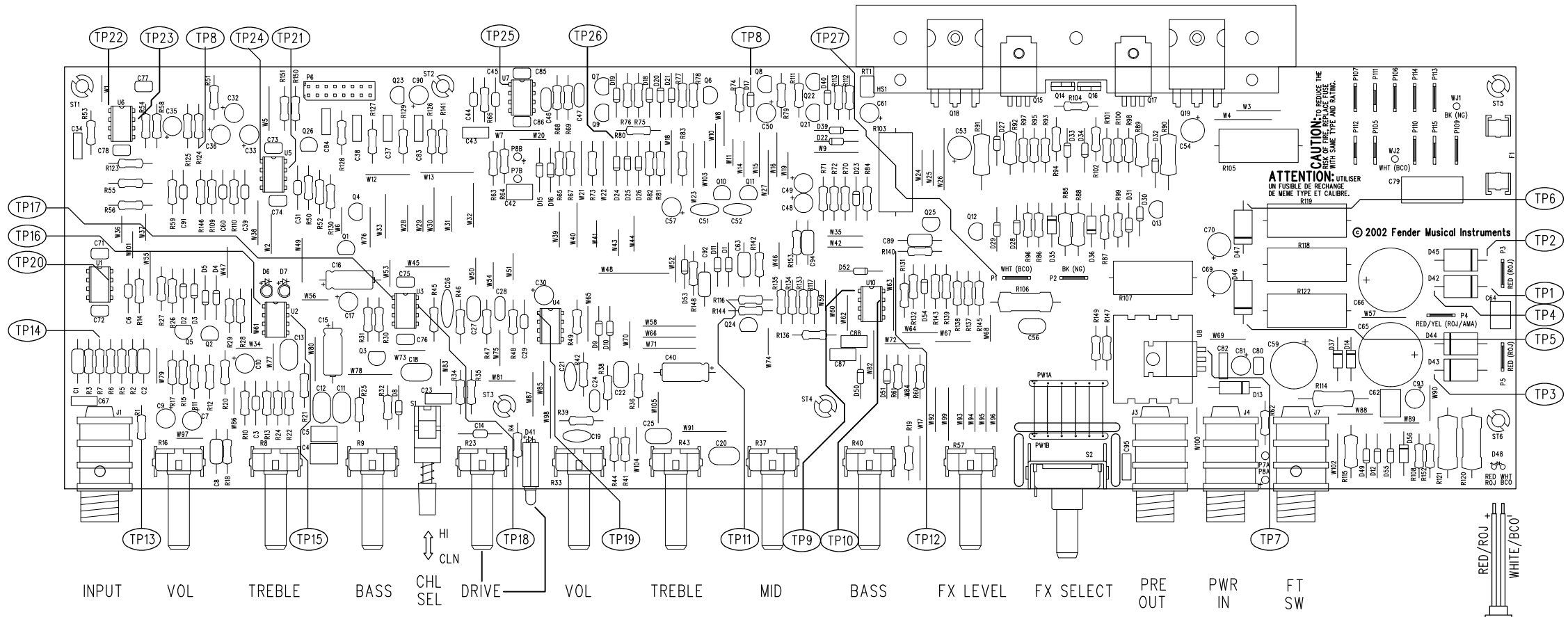

CAUTION: TO REPLACE THE FUSE WITH SAME TYPE AND RATING.
ATTENTION: UTILISER UN FUSIBLE DE RECHANGE DE MEME TYPE ET CALIBRE.
 © 2002 Fender Musical Instruments

FILM/DWG: SERVICE DIAGRAM
 DATABASE: Z500P.PCB DATE: 10-SEP-02

2. MICRO-DSP ASSEMBLY P/N 0057801008 MUST BE CONNECTED TO P6 FOR TEST.
 1. SEE SHEET 1 FOR PRIMARY WIRING, TEST CONDITIONS AND TESTPOINT VALUES.
 NOTES: (UNLESS OTHERWISE NOTED)

THIS DOCUMENT CONTAINS INFORMATION OF A PROPRIETARY NATURE TO FENDER MUSICAL INSTRUMENTS AND IS SUBMITTED TO YOU IN CONFIDENCE AND SHALL NOT BE DISCLOSED OR TRANSMITTED TO OTHERS WITHOUT AUTHORIZATION FROM FENDER MUSICAL INSTRUMENTS.		MUSICAL INSTRUMENTS Corona, CA U.S.A	
CHECKED BY: _____ DATE: _____ APPROVED BY: _____ DATE: _____ DRAWN: ROB HAACK ENGR: ROB HAACK DATABASE FILE: Z500P.PCB		TITLE: SERVICE DIAGRAM, COMBINED (PCB assy) PRINCETON 65 DSP MAIN PCB SIZE: C DRAWING NUMBER: 0057419000 REV. D RELEASE DATE: 04-APR-02 SHEET 2 OF 2	

8 7 6 5 4 3 2 1

REVISIONS			
REV.	DESCRIPTION	DATE	APPROVED
A	PR480	29-NOV-01	J T L
B	EC 2743	07-MAR-02	J T L

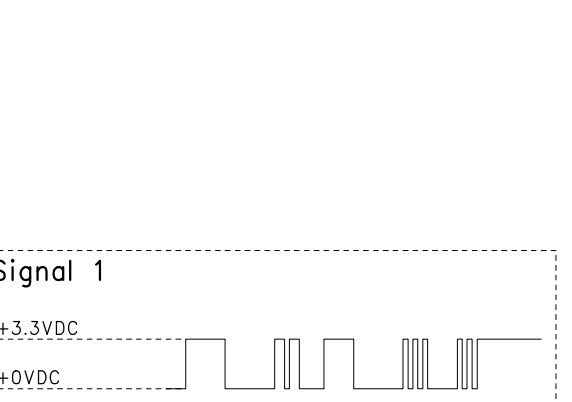
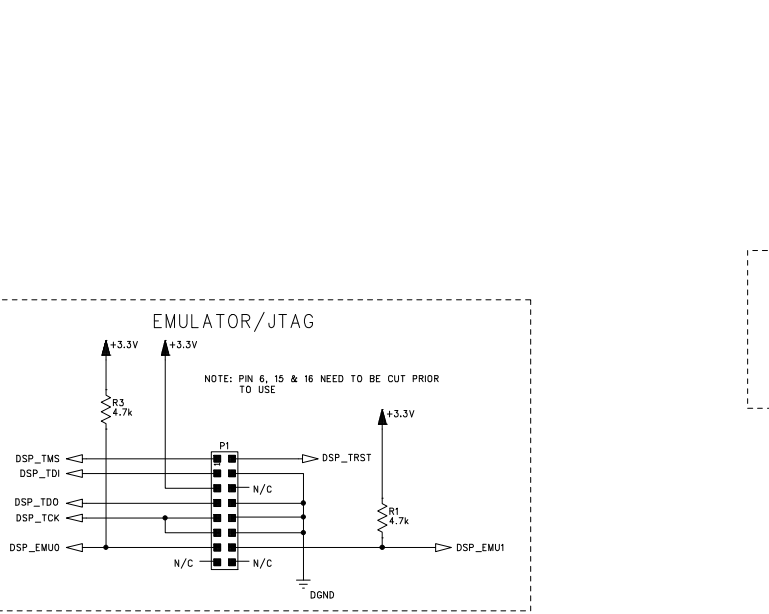
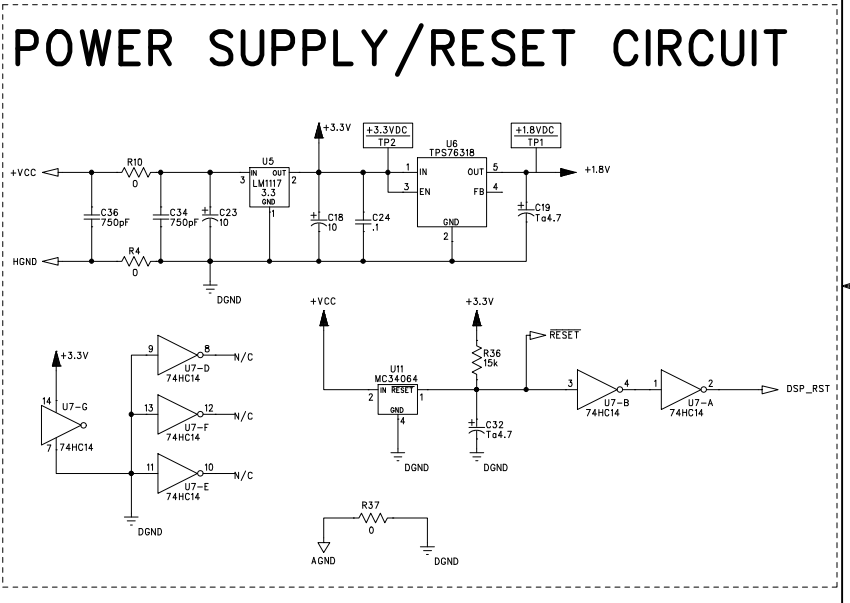
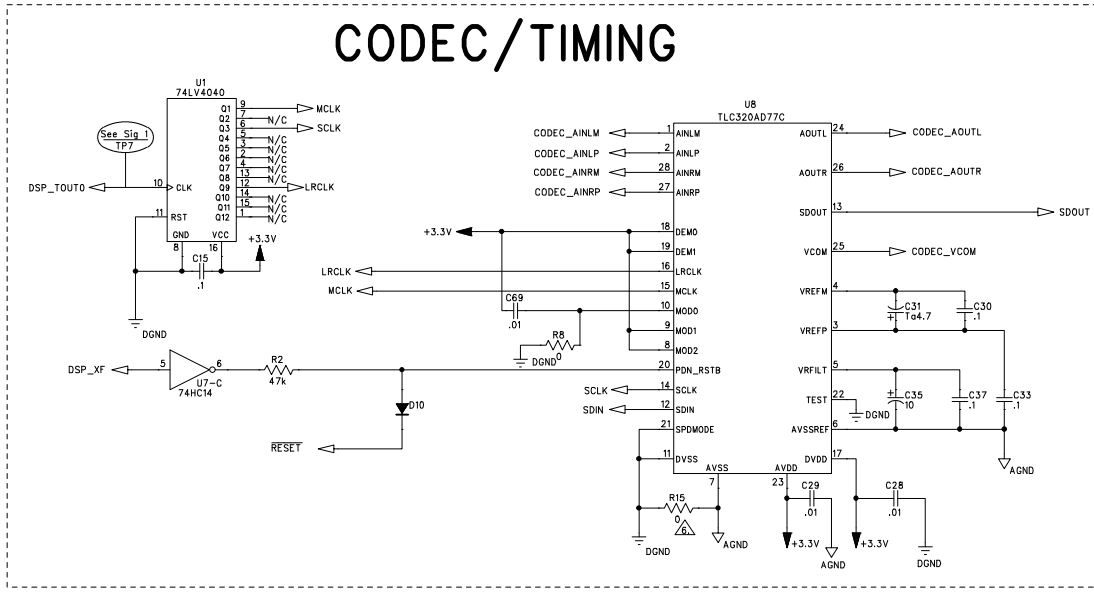
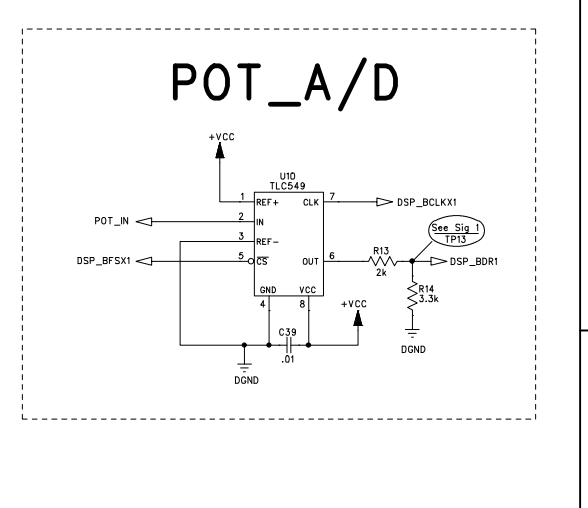
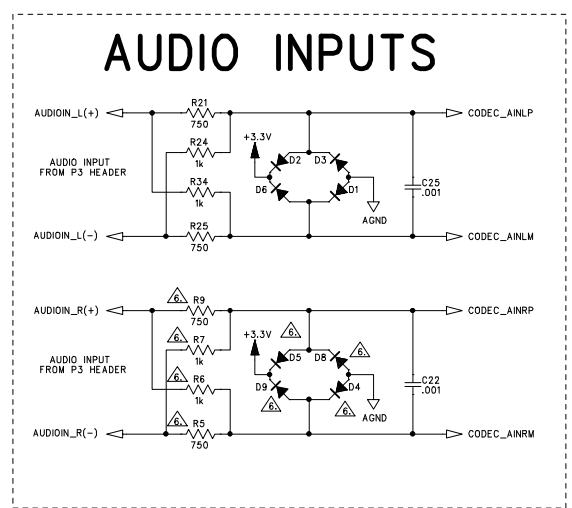
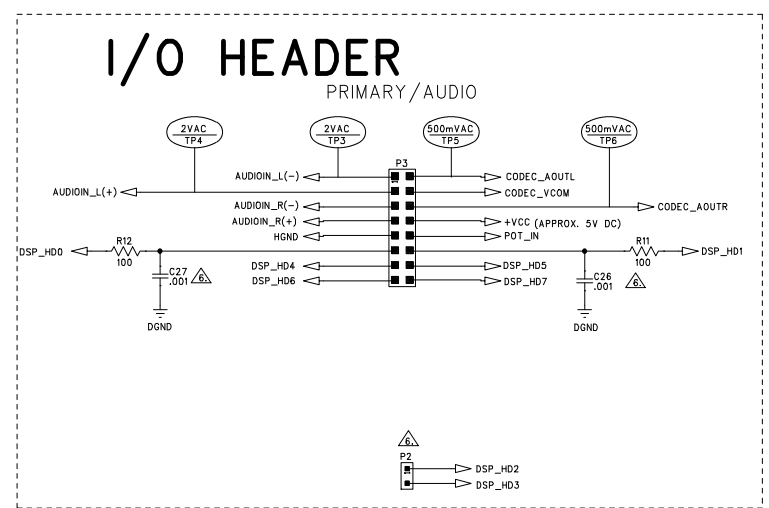
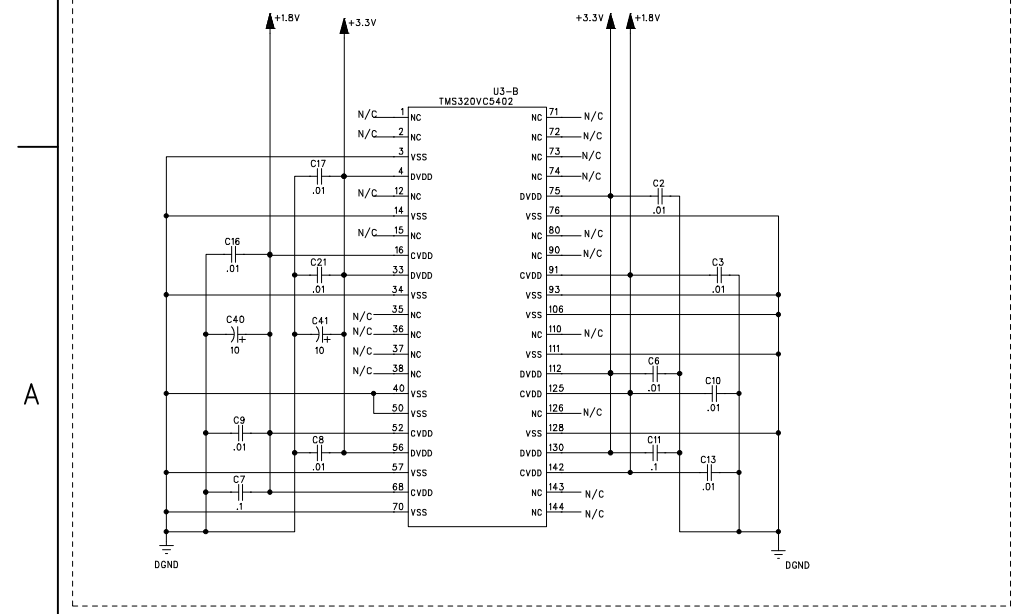
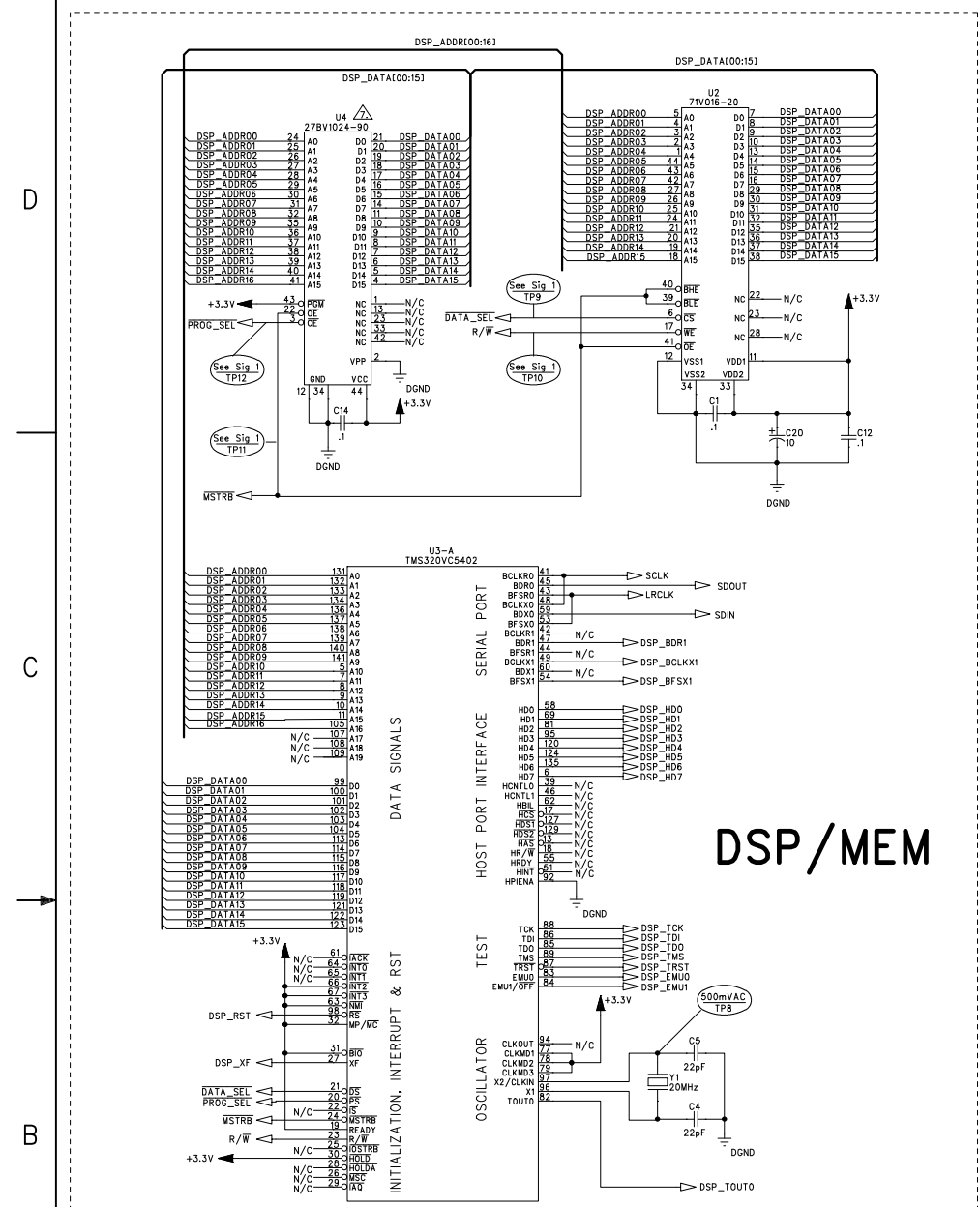

- NOTES: (UNLESS OTHERWISE NOTED)**
- INSTALL IC IN SOCKET. FENDER P/N 0056585005
 - DO NOT STUFF C26-27, D4-5, D8-9, P2, R5-7, R9, R15.
 - THIS SCHEMATIC IS FOR PCB FABRICATION P/N 0057284000 AND PCB ASSEMBLY P/N 0057285000.
 - ALL DIODES ARE 1N4448.
 - ALL POLARIZED CAPACITORS IN uF, 20% 15V MINIMUM.
 - ALL UNPOLARIZED CAPACITORS IN uF, 10% OR BETTER; 16V MINIMUM. (POWER SUPPLY BYPASS CAPACITORS ARE 20%).
 - ALL RESISTORS IN OHMS, 5% 1/10W.

THIS DOCUMENT CONTAINS INFORMATION OF A PROPRIETARY NATURE TO FENDER MUSICAL INSTRUMENTS AND IS SUBMITTED TO YOU IN CONFIDENCE AND SHALL NOT BE DISCLOSED OR TRANSMITTED TO OTHERS WITHOUT AUTHORIZATION FROM FENDER MUSICAL INSTRUMENTS.		Fender MUSICAL INSTRUMENTS Corona, CA U.S.A.	
CHECKED BY:	DATE:	TITLE: SERVICE DIAGRAM, COMBINED (schematic) MICRO DSP	REV. B
APPROVED BY:	DATE:	SIZE: D	DRAWING NUMBER: 0057283000
DRAWN: J. Jimenez	ENGR: J. Lamb	RELEASE DATE: 29-NOV-01	SHEET: 1 OF 2
DATABASE FILE: Z481S.SCH			

REVISIONS

REV.	DESCRIPTION	DATE	APPROVED
A	PR480	30-NOV-01	J T L
B	EC 2743	07-MAR-02	J T L

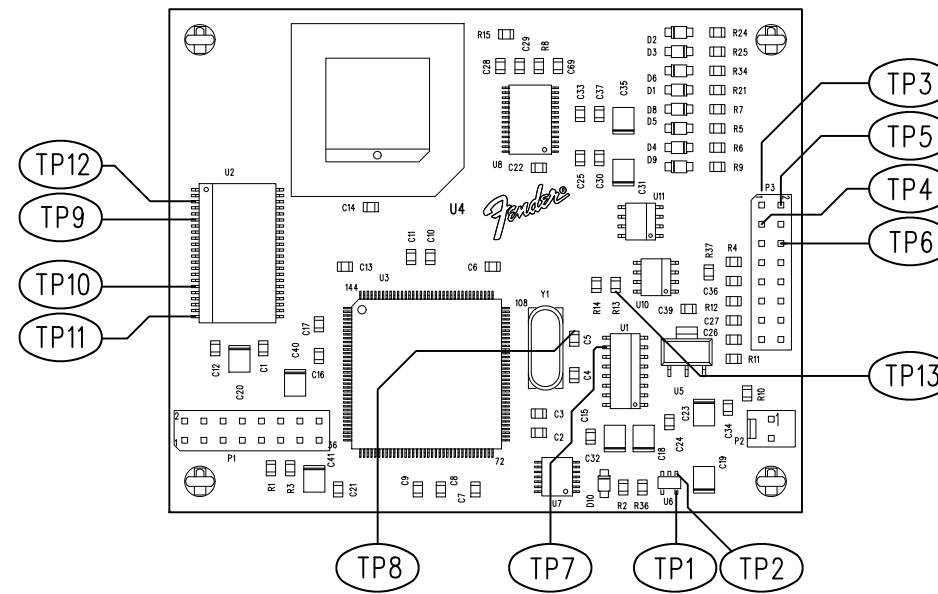

FILM/DWG: SERVICE DIAGRAM
 DATABASE: Z481P.PCB DATE: 07-MAR-02

1. SEE SHEET 1 FOR TEST CONDITIONS AND TEST POINT VALUES.

NOTES: (UNLESS OTHERWISE NOTED)

THIS DOCUMENT CONTAINS INFORMATION OF A PROPRIETARY NATURE TO FENDER MUSICAL INSTRUMENTS AND IS SUBMITTED TO YOU IN CONFIDENCE AND SHALL NOT BE DISCLOSED OR TRANSMITTED TO OTHERS WITHOUT AUTHORIZATION FROM FENDER MUSICAL INSTRUMENTS.		 MUSICAL INSTRUMENTS Corona, CA U.S.A.	
CHECKED BY: _____ DATE: _____		TITLE: SERVICE DIAGRAM, COMBINED (PCB assy) uDSP SERIES	
APPROVED BY: _____ DATE: _____		SIZE B	DRAWING NUMBER 0057283000
DRAWN: J. Jimenez	ENGR: J. Lamb	REV. B	
DATABASE FILE: Z481P.PCB		RELEASE DATE: 30-NOV-01	SHEET 2 OF 2