

# **DN1414**

## **OPERATORS MANUAL**

**Version2**

Klark Teknik Group,  
Klark Teknik Building,  
Walter Nash Road,  
Kidderminster.  
Worcestershire.  
DY11 7HJ.  
England.

Tel:+44 1562 741515  
Fax:+44 1562 745371

Email: [sales@ktgplc.com](mailto:sales@ktgplc.com)  
Website: [www.klarkteknik.com](http://www.klarkteknik.com)



# KLARK TEKNIK GROUP

Walter Nash Road, Kidderminster, Worcestershire. DY11 7HJ. England

Tel: (44) (0) 1562 741515. Fax: (44) (0) 1562 745371

Company Registration No: 2414018

**KLARK TEKNIK**  
SIGNAL PROCESSING BY DEFINITION

**DDA**  
BETTER BY DESIGN

**MIDAS**  
DESIGNED FOR A PURE PERFORMANCE

## DECLARATION OF CONFORMITY

We, **Klark Teknik Group (UK) Plc**

of, Klark Teknik Building, Walter Nash Road, Kidderminster, Worcestershire, DY11 7HJ

Declare that a sample of the following product:-

Product Type Number	Product Description	Nominal Voltage (s)	Current	Freq
DN1414		115V AC 230V AC	130mA 260mA	50/60Hz

to which this declaration refers, is in conformity with the following directives and/or standards:-

Directive(s)	Test Standard(s)
Generic Standard Using EN55103 Limits and Methods	EN50081/1
Class B Conducted Emissions Pavi	EN55103
CLASS B Radiated Emissions Pavi	EN55103
Fast Transient Bursts at 2Kv	EN61000-4-4
Static Discharge at 4Kv	EN61000-4-2
Electrical Stress Test	EN60204

Signed:.....  

Date: 4th February, 2000

Name: David Hoare

Authority: Technical Director, Klark Teknik Group (UK) Plc

Attention!

Where applicable, the attention of the specifier, purchaser, installer or user is drawn to special limitations of use which must be observed when these products are taken into service to maintain compliance with the above directives. Details of these special measures and limitations to use are available on request and are available in product manuals.



# Contents

Thank you for using a Klark Teknik product	Page 1
After you have unpacked	Page 2
Introduction	Page 3
Installation and Connection	Page 4
Basic operation	Page 5
Front Panel	Page 6
Rear Pane	Page 7
Rear panel blanking plate and iser multipole connectors	Page 8
Block Diagram	Page 9
Applications	Page 10
Appendices	Page 11
Specifications	Page 12
Schematics	Page 13



## **Thank You For Using This Klark Teknik Product**

To obtain maximum performance from this precision electronic product, please study these instructions carefully. Installation and operating the mic splitter is not complicated, but the flexibility provided by its operating features merits familiarisation with its controls and connections. This unit has been prepared to comply with the power supply requirements that exist in your location.

### **Precautions**

Do not install this unit in a location subjected to excessive heat, dust or mechanical vibration.

### **Voltage Selection and Power Connection**

Connection is made by means of an IEC standard power socket. The rear panel text indicates the voltage range required for satisfactory operation of the unit.

Before connecting this unit to the mains supply, ensure the fuse fitted is the correct type and rating is as indicated on the rear panel, adjacent to the fuse holder.

### **Safety Warning**

This unit is fitted with 3-pin power socket: For safety reasons the earth lead should not be disconnected. Signal ground is referenced internally to chassis via a resistor capacitor network which provides earth loop immunity.

To prevent shock or fire hazard, do not expose the unit to rain or moisture. To avoid electrical shock do not remove covers. Refer servicing to qualified personnel only.

### **Attention!**

#### **Cables:**

This product should only be used with high quality, screened twisted pair audio cables, terminated either with metal bodied 3-pin XLR connectors (with the cable screen connected to pin 1) or ¼" jacks. Any other cable type or configuration for the audio signals may result in degraded performance due to electromagnetic interference.

#### **Electric Fields:**

Should this product be used in an electromagnetic field that is amplitude modulated by an audio frequency signal (20Hz to 20kHz), the signal to noise ratio may be degraded. Degradation of up to 60dB at a frequency corresponding to the modulation signal may be experienced under extreme conditions (3V/m, 90% modulation).

## After You Have Unpacked The Unit

Save all the packing materials - they will prove valuable should it become necessary to transport or ship this product.

Please inspect this unit carefully for any signs of damage incurred during transportation. It has undergone stringent quality control inspection and tests prior to packing and left the factory in perfect condition.

If, however, the unit shows any signs of damage, notify the transportation company without delay. Only you, the consignee, may institute a claim against the carrier for damage during transportation.

If necessary, contact your supplier or as a last resort, your Klark Teknik importing agent, who will fully co-operate under such circumstances.

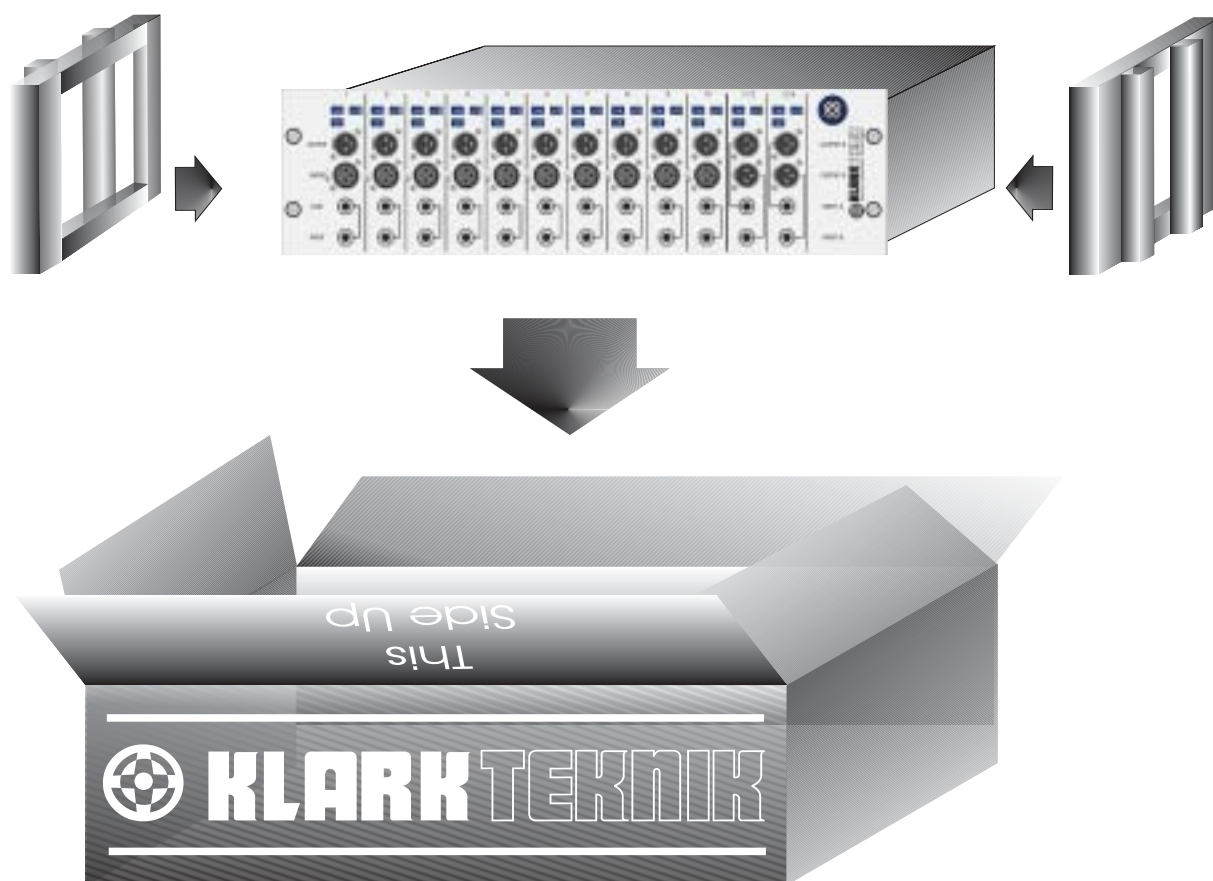



## **Introduction**

The DN1414 Multiple DI Module offers a cost and space-effective method of providing 14 discrete channels of transformer-isolated direct injection. Housed in a rugged 3U rack enclosure, the DN1414 embodies the legendary sound and reliability of Klark Teknik.

### Key Features

- i Ten mono channels with XLR and jack inputs, link output jack and transformer -balanced XLR outputs.
- ii. Two dual channels with jack inputs, link output jacks and transformer-balanced XLR outputs
- iii. -30dB pad, -15 dB attenuation on all channels.
- iv. Internal power supply with factory option of backup PSU.
- v. Five year international factory warranty.

The Klark Teknik DN1414 is an extremely high performance, 14-channel DI module housed in a 3U, rack mounting case with an integral switch mode power supply that automatically adapts to mains voltages in the range 100 to 240 Volts (50 to 60Hz). A dual PSU is available as a factory fitted option. Applications include providing DI box feeds to service monitor and FOH consoles as well as to facilitate the multitrack recording of live events.

Each input feeds a superbly specified input stage, which can flexibly handle both line- and instrument-level signals. The TRS jack and XLR inputs on channels 1-10 are parallel connected, and the circuit design allows the DN1414 to handle either balanced or unbalanced signals without loss. A 20k ohm input impedance is presented when the XLR input connector is used, this impedance is switched out when the jack input is used, to avoid high-frequency loading effects when the DN1414 is used with unbuffered guitar pick-ups. All connectors are mounted on the front panel for easy access. Two pad/attenuator switches (-30dB and -15dB) may be used individually or in combination to provide unity, -15 dB, -30 dB or 45 dB gain. Each DI channel output is also fitted with a ground lift switch.

## **Installation And Connection**

The Klark Teknik DN1414 is designed for standard 19" rack mounting and occupies 3U of rack space. Avoid mounting the unit directly above or below power amplifiers or power supplies that radiate excessive magnetic fields or heat. Ensure that the ventilation apertures on either side of the unit are not blocked or obstructed.

This unit must be earthed. If ground loop problems are encountered, the ground lift switches on the channel outputs may be used. It is also permissible to disconnect the cable screen at one end or other of the output cables, though the signal input cable screen must be connected at both ends to ensure the phantom powering operates correctly.

The mains fuse should be T0.5L250V.

The transformer-balanced outputs have a maximum signal capability of +18dB. For unbalanced use, pin 3 of any output XLR may be grounded at the destination end of the cable. These outputs have a source impedance of 70  $\Omega$  and are designed to feed a minimum load of 600  $\Omega$ .

## Basic Operation

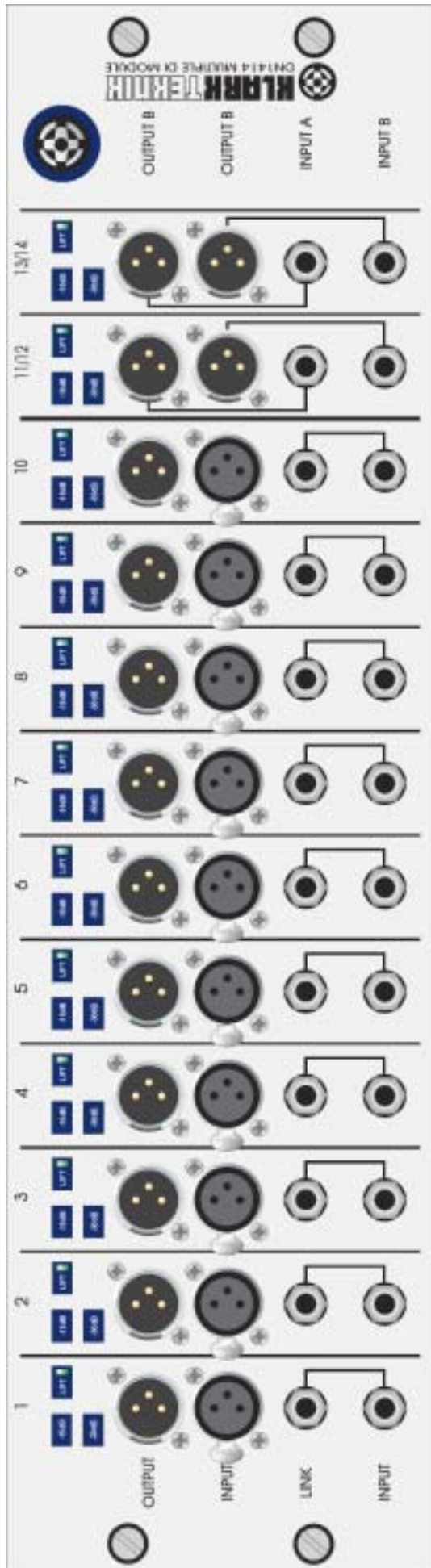

Ensure that the sound system level is turned down at this stage to prevent switch-on thumps or acoustic feedback. The transformer balanced outputs offer exceptional audio quality combined with excellent line driving capability. In addition they offer absolute electrical isolation, which is essential in situations such as running feeds to mobile studios or outside broadcast facilities.

**Illuminated Logo** The DN1414 has no mains power switch. When power is connected, the logo at the front right of the panel will illuminate.

# Front Panel

## Channels 1 to 10

-15dB Switches in a 15dB attenuator. (Note that both switches may be used together when -45dB attenuation is required.)

-30dB Switches in a -30dB pad in front of the input buffer stage.

Input Balanced TRS jack socket, parallel-connected with a 3-pin female XLR.

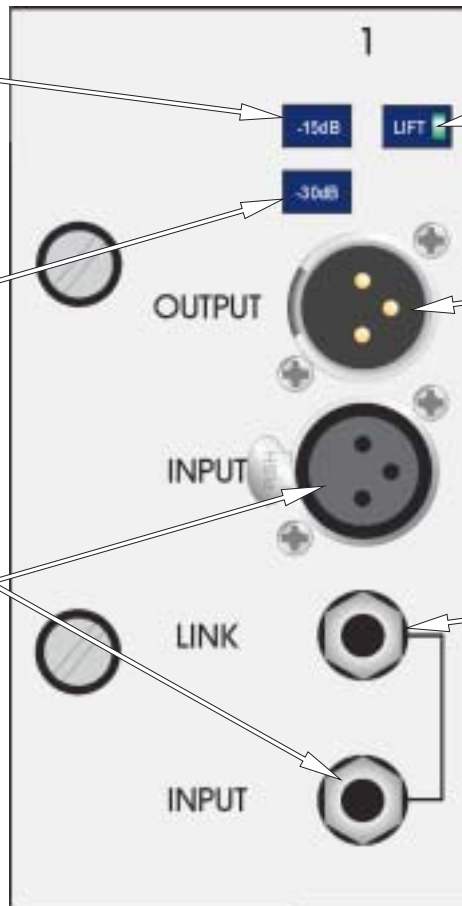

Lift Isolates the output signal ground.

Output Transformer balanced XLR output.

Link Unbalanced TS jack socket.

## Channels 11/12 and 13/14

Lift Isolates the output signal ground affects both channels.

-15dB Switches in a 15dB attenuator. (Note that both switches may be used together when -45dB attenuation is required.) affects both channels.

30dB Switches in a -30dB pad in front of the input buffer stage affects both channels.

Outputs Transformer balanced XLR output.

Inputs Balanced TRS jack sockets.

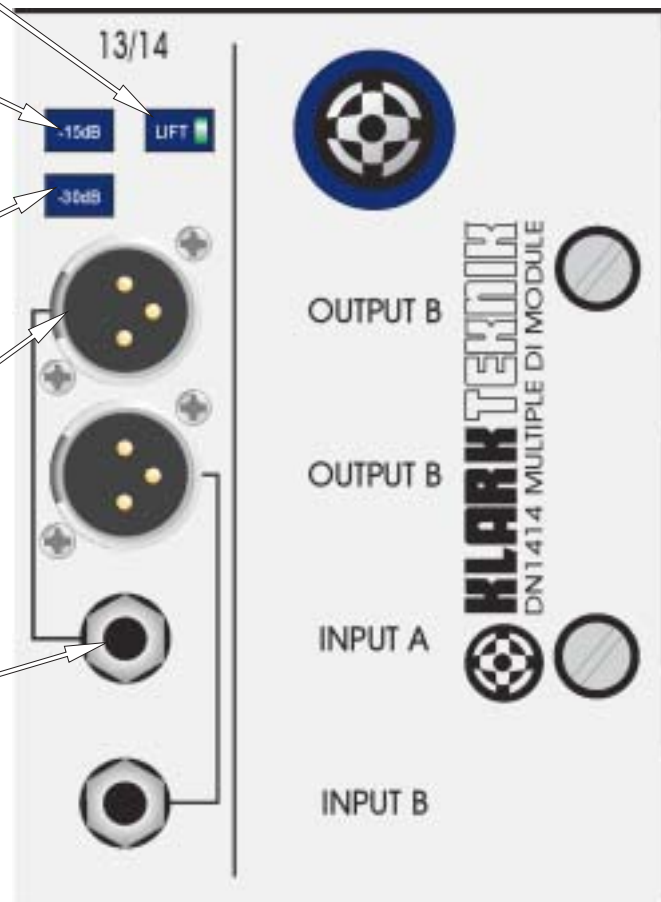

# Rear Panel

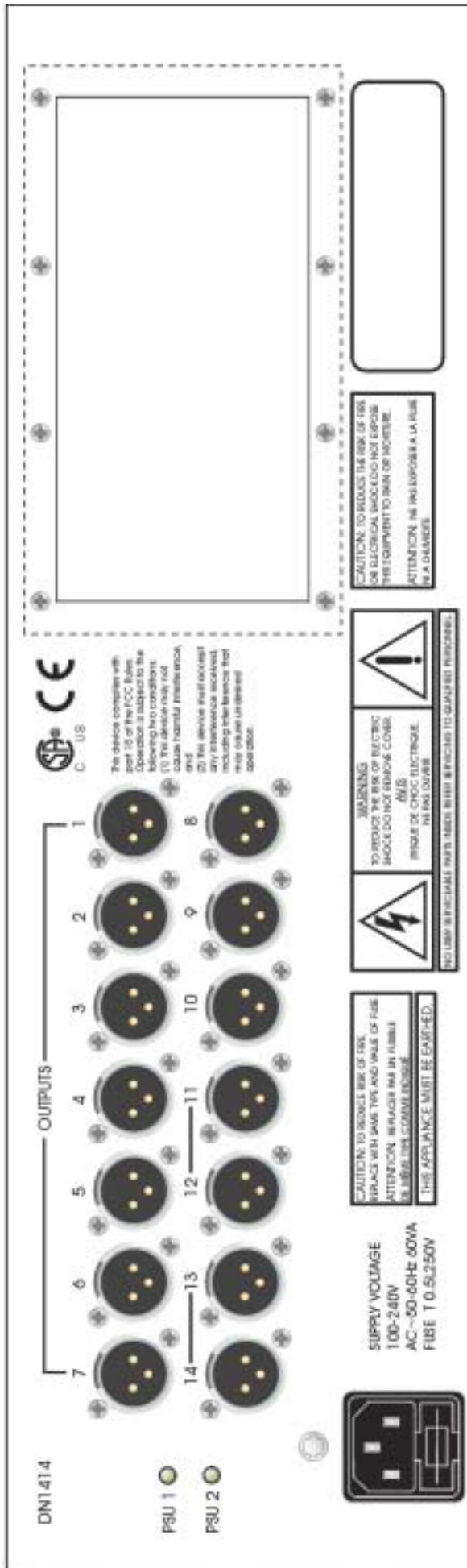

## Blanking plate

Dimensions of the plate: 158mm x 88mm  
 Internal dimensions: 140mm x 70mm

## Mains Inlet

Standard non-switched IEC mains connector. A suitable cable is provided.

## Rear Panel Blanking Plate and User Multipole Connections

The rear panel has a removable blanking plate which is designed for users to fit their choice of multipole connectors. The circuit board for each for the twelve channels has a row of spring-leaf terminals along its rear edge to allow users to terminate cables from the multipole connectors.

The top cover should be removed from the unit to gain access to the blanking plate and the circuit board terminals. Please ensure that all screws are retained and used to re-attach the cover and blanking plate. ***Any warranty claims resulting from damage to the unit will be void if all of the screws are not used to re-secure both the cover and the blanking plate.***

The outputs are brought out to the circuit board terminals; to make a connection insert a small flat-bladed screwdriver into the upper rectangular slot and using a levering motion, move the screwdriver away from the circuit board - this action will open the contacts in the lower opening in the connector so that the bare ends of a wire can be inserted. Moving the screwdriver in the other direction will close the contacts, which will then hold the wire securely. ***Any warranty claims will be void if the damage has been caused by excessive force to these multipole connectors.*** It is recommended that screened twisted pair cable is used to make the connections between the individual circuit boards and the multipole connectors.

The connectors are as shown below for both the mono and dual channel circuit boards:

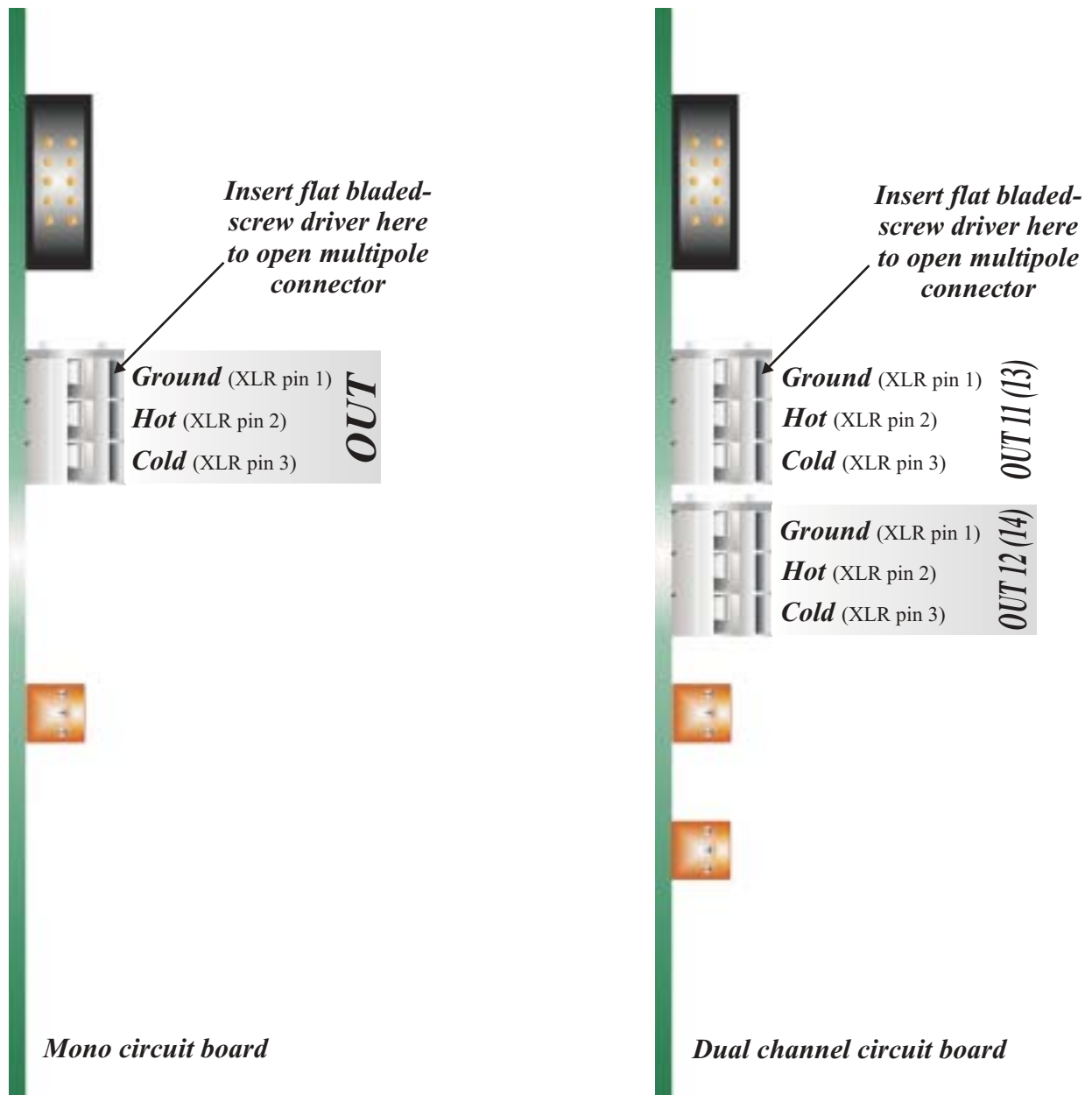



## Block Diagram

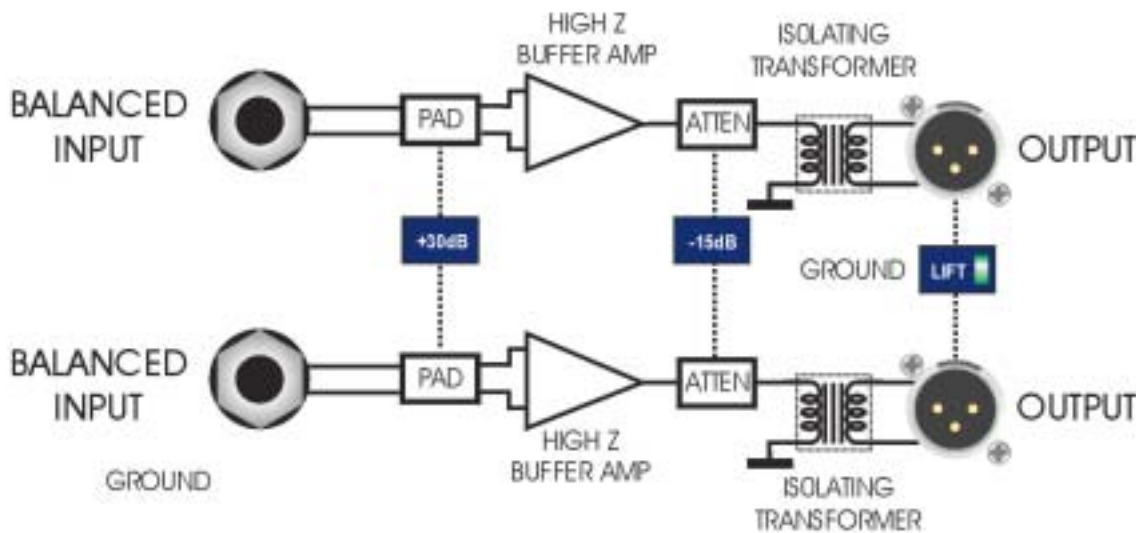
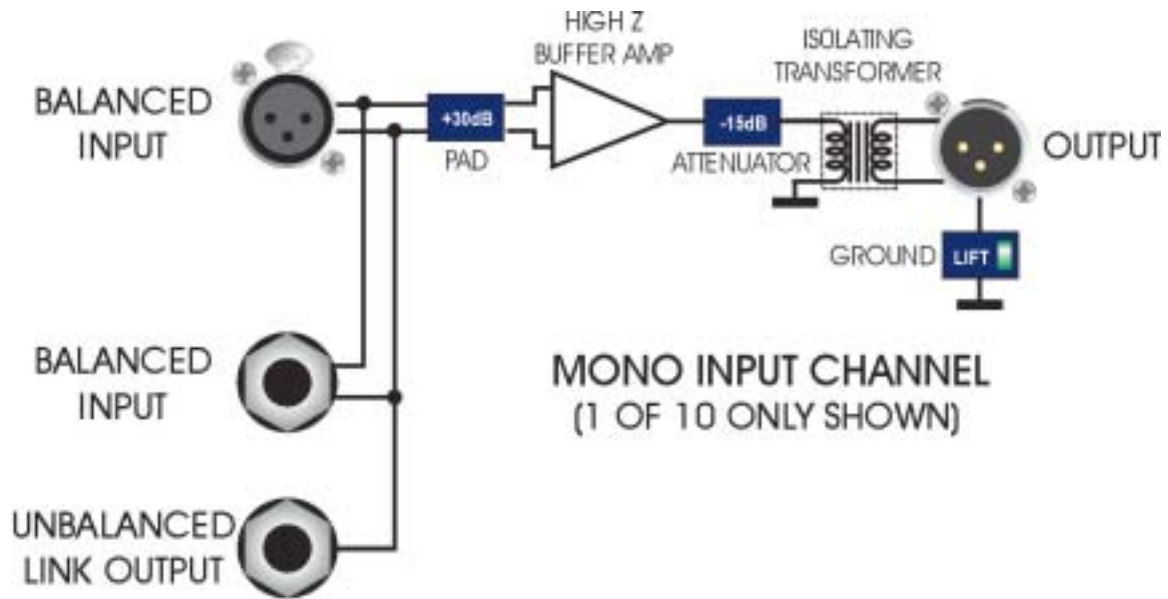

### DI Channel Configuration

The DI module input stage uses the same buffered preamplifier that is employed on many Klark Teknik products and features exception low noise and distortion combined with a generous level of headroom, as well as being able to handle both balanced and unbalanced input connections without signal loss. The parallel-connected XLR and TRS jack inputs on channels 1-10 are designed to be used one at a time, the XLR input has a 20k ohms input impedance, this is switched out when a jack plug is inserted so that guitars, especially passive ones, can be used without loss of high frequency signal content. The nominal input impedance when using the jack input is 1 M ohms. A -30dB pad can be switched in front of the buffer stage to avoid clipping. A further separately buffered 15 dB attenuator is also included. The separate buffering means that there will be no interaction between the pad and the attenuator when they are both switched in. With neither selected, the signal path is unity gain. The gain range is adequate to accommodate most keyboards, sound modules, instrument preamplifier outputs and active and passive guitars and basses.

## Applications

In a live concert situation, the DN1414 is used to provide an isolated transformer-balanced feed suitable for long cable runs from the stage to mixing desks. The main uses for the DN1414 are for providing interfaces for unbalanced outputs from electronic keyboards, sound modules or instrument pre-amplifiers, or for instruments such as bass and electro-acoustic guitars which would not normally be used with a microphone.

*Example 1* shows the usage with a bass guitar. The unbalanced output from the bass is connected to the jack input of the DN1414, and the link output is used to provide a through connection to the bassist's on-stage amplifier. The transformer output is then used to provide a balanced feed to the monitor and/or FOH desks.

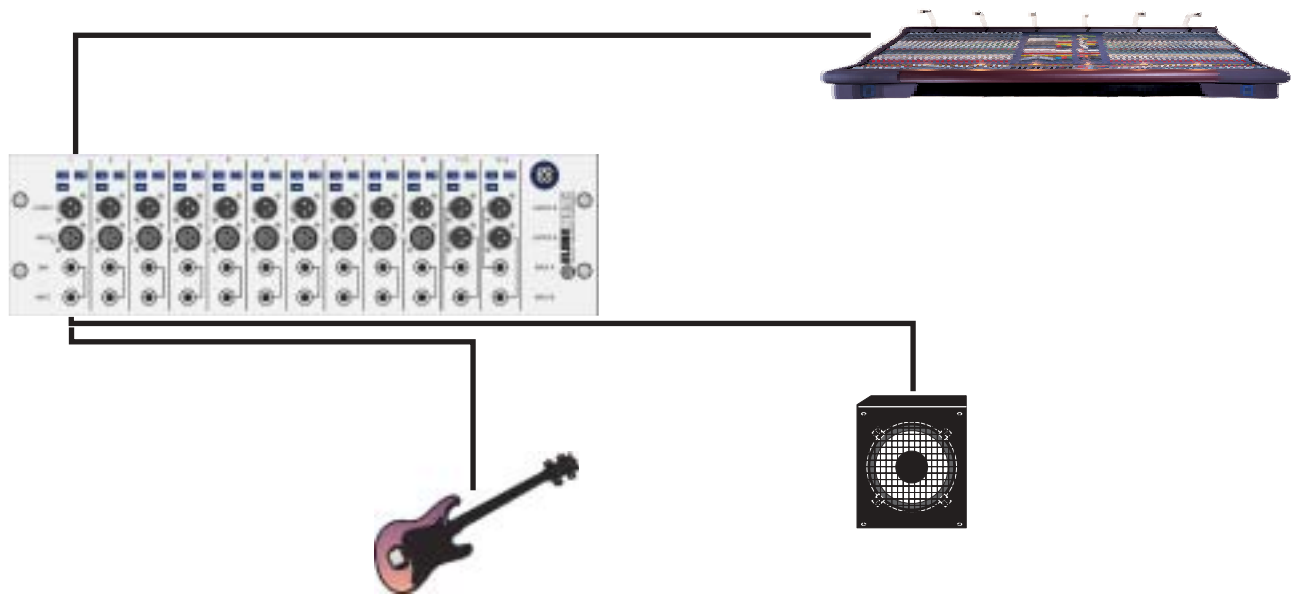

*Example 2* shows the usage as an interface for a number of on-stage keyboards and sound modules. These units do not normally have balanced outputs suitable for driving long cable runs, and so the use of DI units is essential in this application. The compact rack-mounting format of the DN1414 makes it ideal for inclusion in a keyboard rack. The transformer outputs are used to provide individual balanced feeds to the monitor and/or FOH desks.

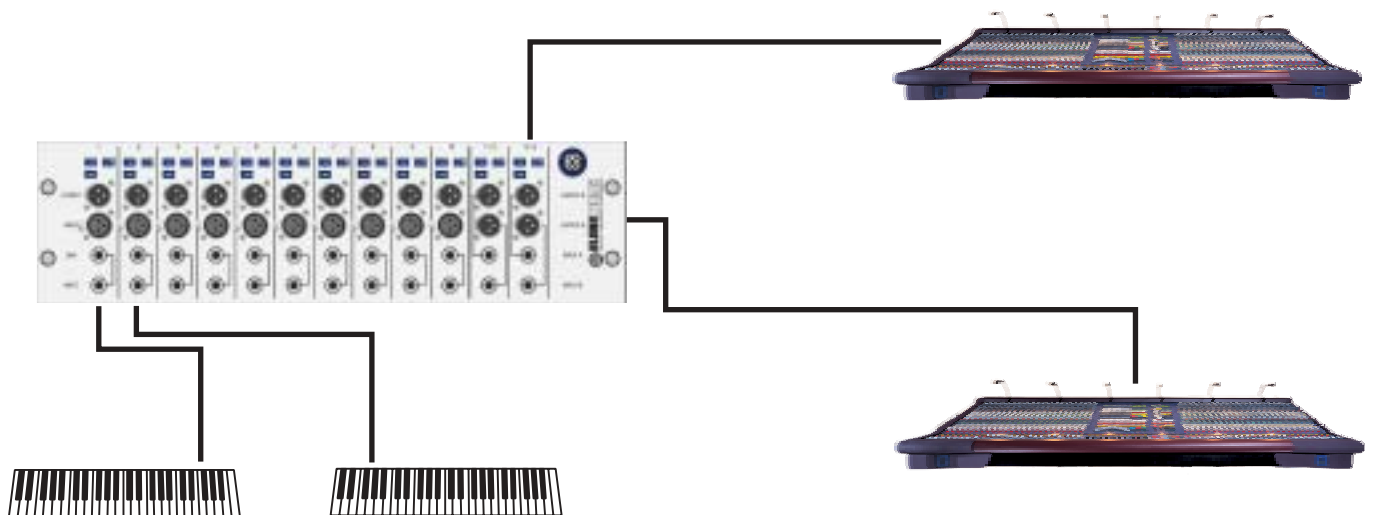



## Appendices

### *Architect's And Engineer's Specification*

The Multiple DI Module shall provide 14 discrete audio channels in a standard 3U 19" rack mount chassis, each channel providing galvanic isolation and impedance matching for a variety of input signals.

Each channel shall also provide separate -30 dB pad and 15 dB attenuation switches, and an earth lift function.

Each Multiple DI Module shall meet or exceed the following performance specifications:

Distortion	< 0.01% (1 kHz +4 dB)
Frequency response	+/- 1.0 dB (20 Hz to 20 kHz)

The DI Module shall have ten single audio channels and two dual audio channels. All channels shall have a ¼" TRS jack input which is capable of accepting balanced or unbalanced inputs. The ten single audio channels shall have a female 3-pin XLR connector in parallel with the jack socket. In use the XLR input shall present a 20k ohm input impedance and the ¼" jack socket a nominal 1M ohm input impedance.

The ten single channels shall also have an unbalanced link output on a ¼" TS jack socket.

All outputs shall be transformer isolated and shall use 3-pin male XLR connectors.

The unit shall be capable of operating from a 100 to 240V, 50 to 60 Hz AC power source.

The DI Module shall be the Klark Teknik model DN1414 and no alternative option is available.

## **Specifications**

### ***Inputs***

*Electronically balanced*

Input impedance	1M nominal (Unbalanced) 20k (Balanced)
Max level	+ 21dBu with no input attenuation
Attenuation	- 15dB
Pad	- 30dB
Connectors	Parallel-connected ¼ " TRS jack sockets and 3-pin female XLRs.

### ***Outputs***

*Transformer isolated*

Source impedance	50
Min Load	600 (-3dB level loss into 20 )
Max level	> + 18dBu @ 1kHz with load > 1k
Connectors	3-pin female XLRs.

*Link Output (Channels 1-10)*

Connectors	¼" TS Mono Jack Socket
------------	------------------------

### ***Performance***

Noise	-100 dBu between 20Hz and 20 kHz unweighted
Frequency response	+/- 1dB, 2Hz to 20kHz
Distortion	<0.01% @ 1kHz, +4dBu output

### ***Power Requirements***

100 to 240 V a.c @ 50/60 Hz @ < 75 VA  
3 pin IEC connector.

### ***Dimensions***

Width	483 mm (19 inches)
Height	132 mm (5.2 inches)
Depth	300 mm (12 inches)

### ***Weights***

Nett	8 kg
Shipping	9 kg

# Schematic Drawings

## DN1414

Mutiple DI Module Power Schematic  
Mutiple DI Module Stereo (Mono Option) Schematic 1  
Mutiple DI Module Stereo (Mono Option) Schematic 2



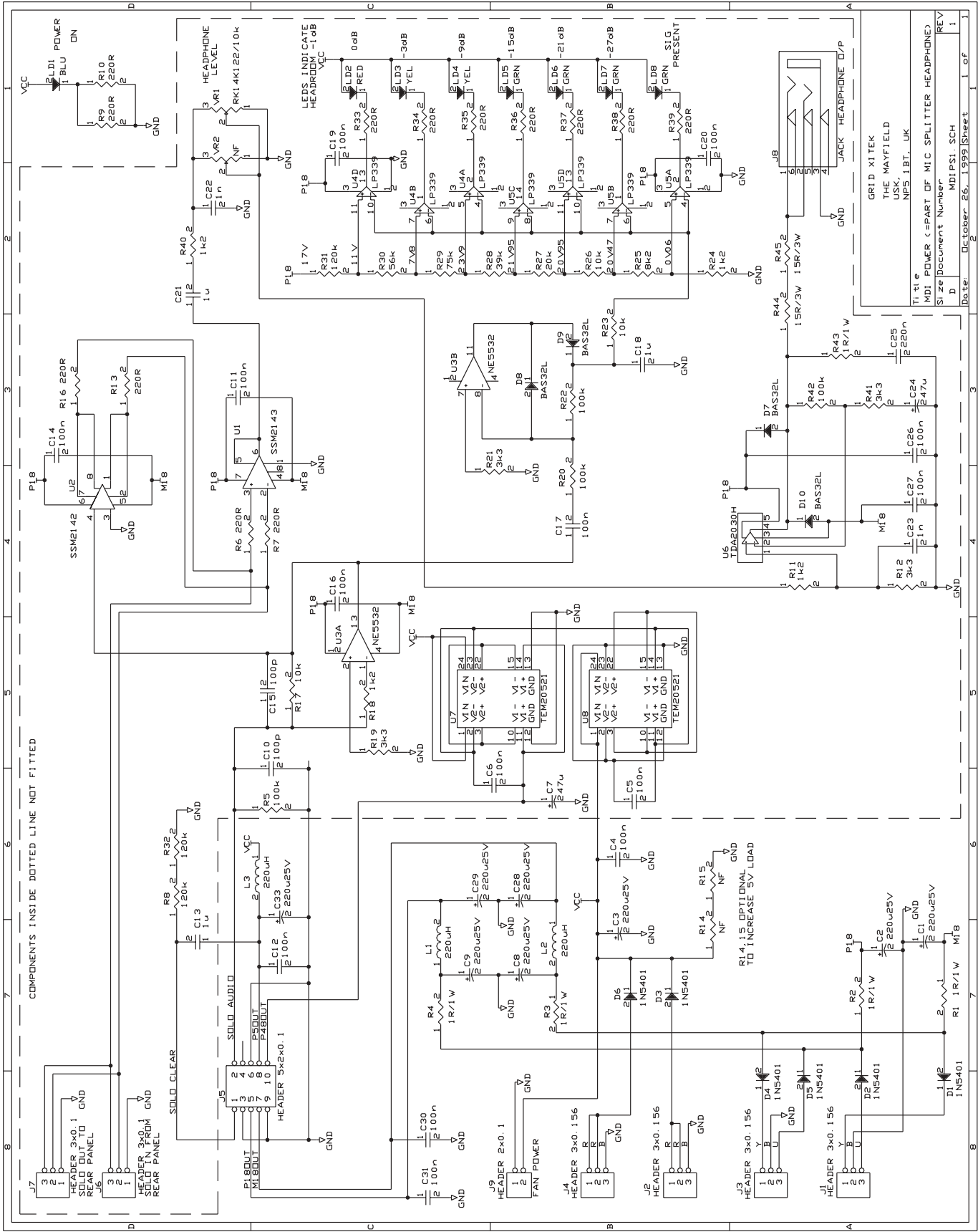

COMPONENTS INSIDE DOTTED LINE NOT FITTED

Title	GRID XITEK
Author	THE MAYFIELD
Company	USK
Address	NP5, I.B.T., UK
Document Number	MDPS1.SCH
REV	1

Date: October 26, 1999 | Sheet 1 of 1



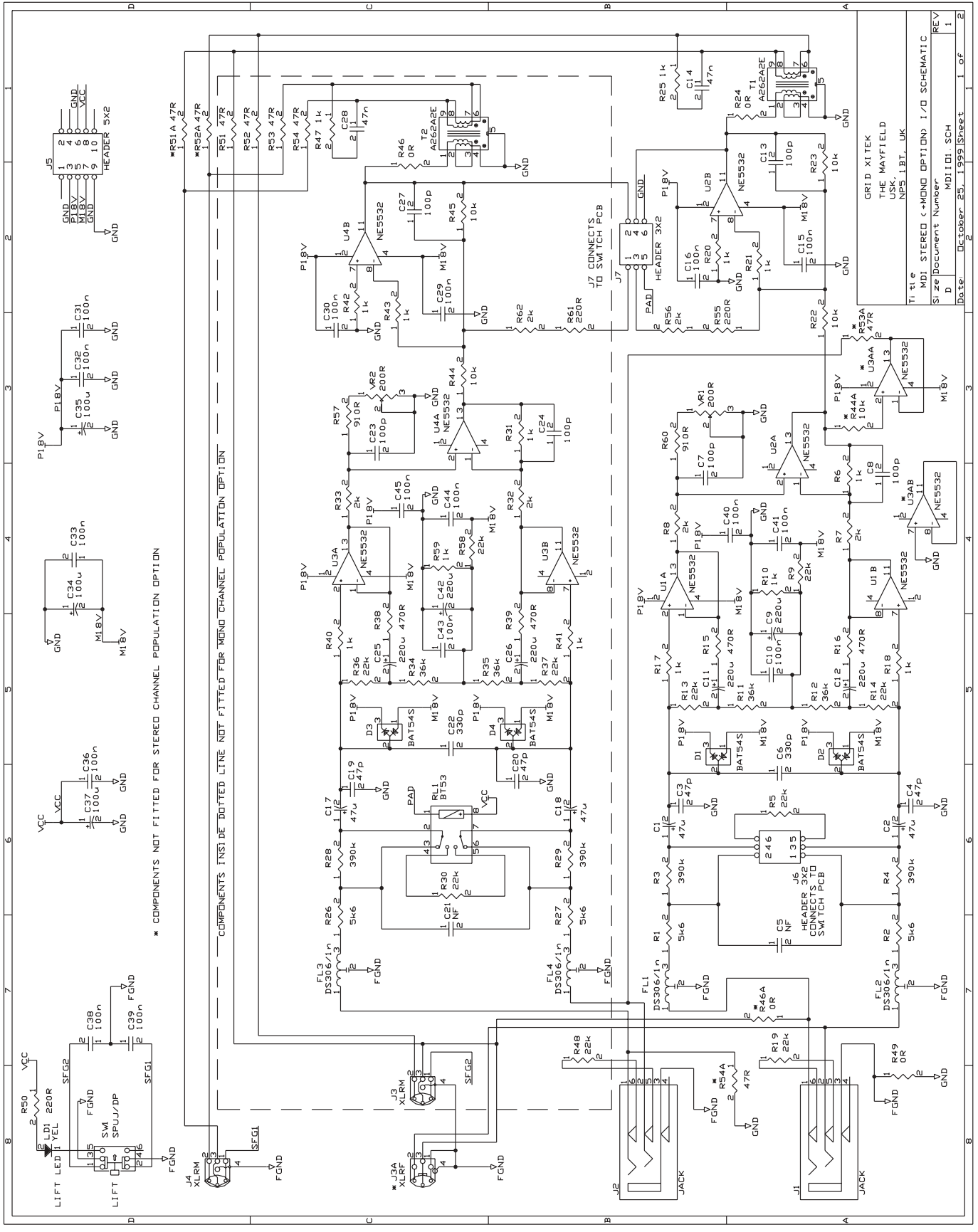

\* COMPONENTS NOT FITTED FOR STEREO CHANNEL POPULATION OPTION

COMPONENTS INSTALLED DOTTED LINE NOT FITTED FOR MONO CHANNEL POPULATION OPTION

GRID XI TEK  
 THE MAYFIELD  
 USE  
 NPS\_LBT, UK

Title  
 MDI STEREO (+MONO OPTION) I/D SCHEMATIC  
 Size  
 Document Number MDI01.SCH  
 Date  
 October 25, 1999 Sheet 1 of 2





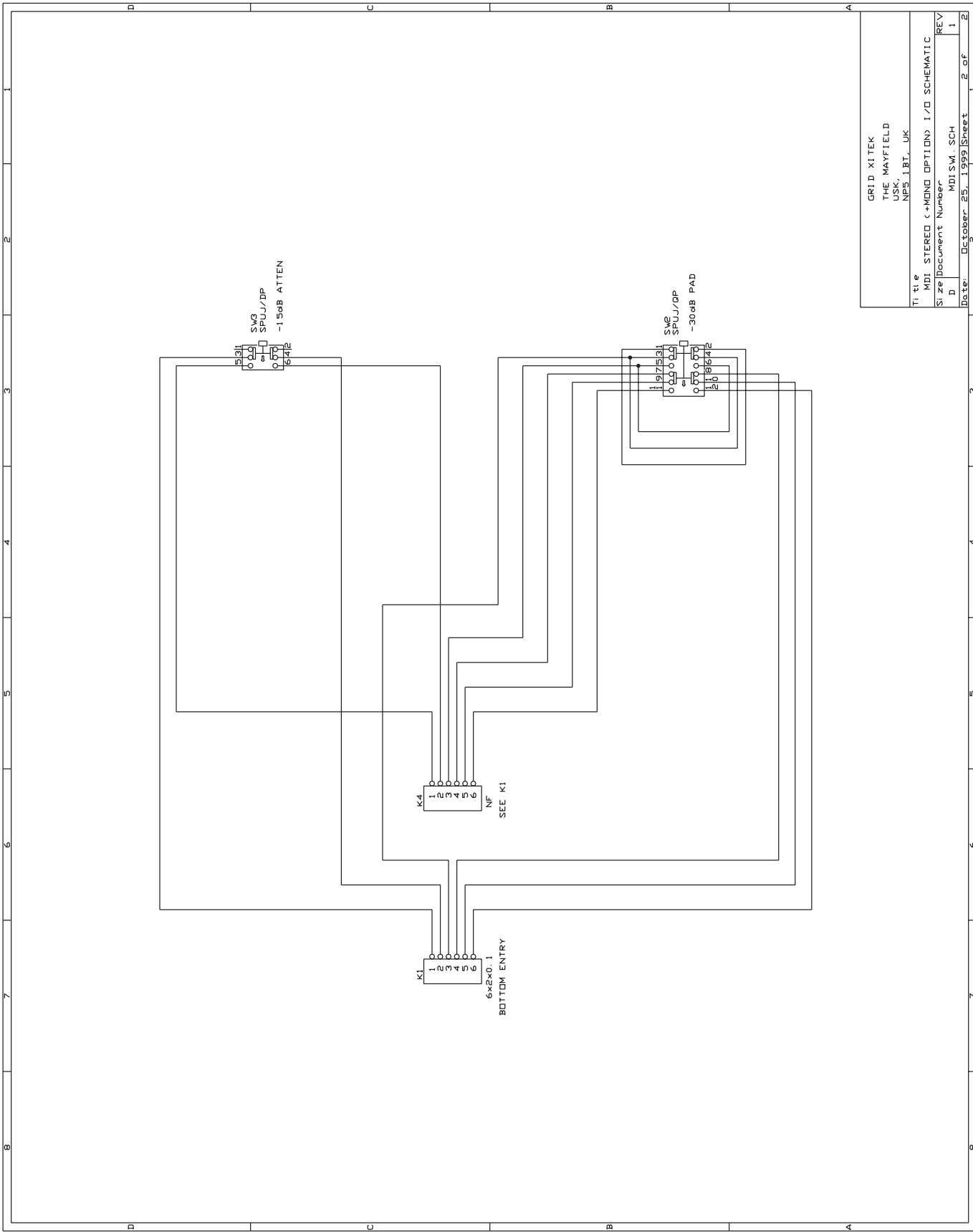

GRID XITEK	
THE MAYFIELD	
USK.	
NPS, I.B.T., UK	
Title	MDI STEREO (+MONO OPTION) I/O SCHEMATIC
Size	Document Number
D	MDI SW.1. SCH
Date:	October 25, 1999
Sheet	2 of 2
REV	1

