

KORG

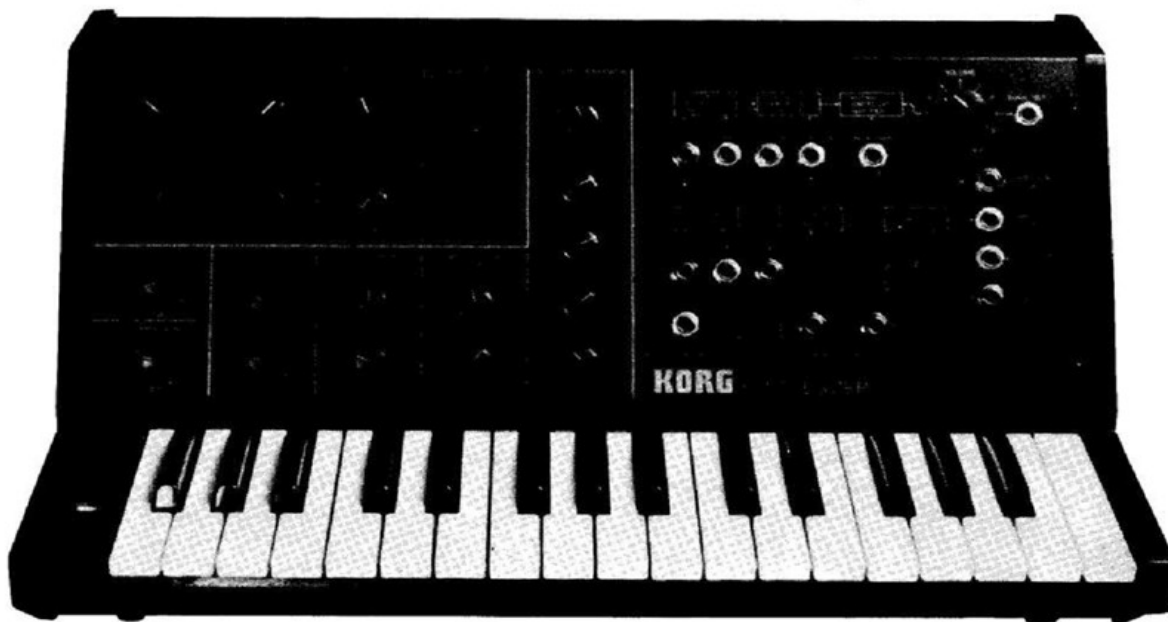

MONOPHONIC SYNTHESIZER
SERVICE MANUAL **MS-10**

CONTENTS

1. SPECIFICATIONS.....	2
2. STRUCTURAL DIAGRAM.....	3
3. CIRCUIT DIAGRAM.....	4
4. PRINTED CIRCUIT BOARD KLM-126B.....	5
5. PARTS LIST (Mechanical parts not listed).....	6
6. BLOCK DIAGRAM.....	7
7. ADJUSTMENT PROCEDURE.....	8

KEIO ELECTRONIC LABORATORY CORPORATION
TOKYO/JAPAN

1. SPECIFICATIONS

< CONTROL SECTION >

- | | |
|---------------------------------------|--|
| 1. Keyboard | * F~C 32 Keys/(2-2/3 octaves) |
| 2. Voltage controlled oscillator | * Scales [32', 16', 8', 4',]/
+ 6 octaves (FM)
* Wave form [∧, ∨, PW/PWM, Noise]/(4 modes)
* PW adjust/PWM intensity
* Pitch [1 OCTAVE OR MORE]
* portamento
* Frequency modulation intensity by MG
* Frequency modulation intensity by EG/EXT |
| 3. Voltage controlled low pass filter | * Cut-off frequency
* Peak [flat ~ self OSC]
* Cut-off frequency modulation intensity by MG
* Cut-off frequency modulation intensity by EG/EXT |
| 4. Envelope generator | * Hold time
* Attack time
* Decay time
* Sustain level
* Release time |
| 5. Modulation generator | * Wave form [∧, ∨, ∩, ⊓, ⊔, ⊕]
CONTINUALLY
* Frequency |
| 6. External input | * Signal level adjust |
| 7. Manual controller | * Control wheel CENTER CLICK STOP |
| 8. Power, SW Ä volume | * Volume |

< PATCH PANEL SECTION >

- | | |
|-----------------------|---|
| 1. Keyboard | * Keyboard control voltage output (exponential)/0V ~ +8V
* Keyboard trigger output/⏏ _{GND} |
| 2. VCO | * VCO control voltage input (linear response)/0V ~ +8V
* External frequency control input (OCT/V)/-3V ~ +3V
* External pulse width modulation input/-5V ~ +5V |
| 3. VCF | * External signal input/3VPP max.
* External cut-off frequency control input (20OCT/V)/-5V ~ +5V |
| 4. VCA | * Initial gain control input/0V ~ +5V |
| 5. EG | * External trigger input/⏏ _{GND}
* Envelope signal reverse output/-5V ~ +5V |
| 6. MG | * Triangle output (∧-∨-∩)/5VPP
* Rectangle output (⊓-⊔-⊕)/0↔+5V |
| 7. Noise generator | * Pink noise output/5VPP
* White noise output/5VPP |
| 8. Manual controller | * Control wheel output/-5V ~ 0V ~ +5V |
| 9. Signal out | * Signal output/2VPP max. (output impedance 3.5kΩ) |
| 10. Power consumption | * 5 Watts |
| * Dimension | * 499(W) x 309(D) x 249(H) mm |
| * Weight | * 6.3 kgs |
| * Accessories | * Patch cord/35 cm x 1 |

2. STRUCTURAL DIAGRAM

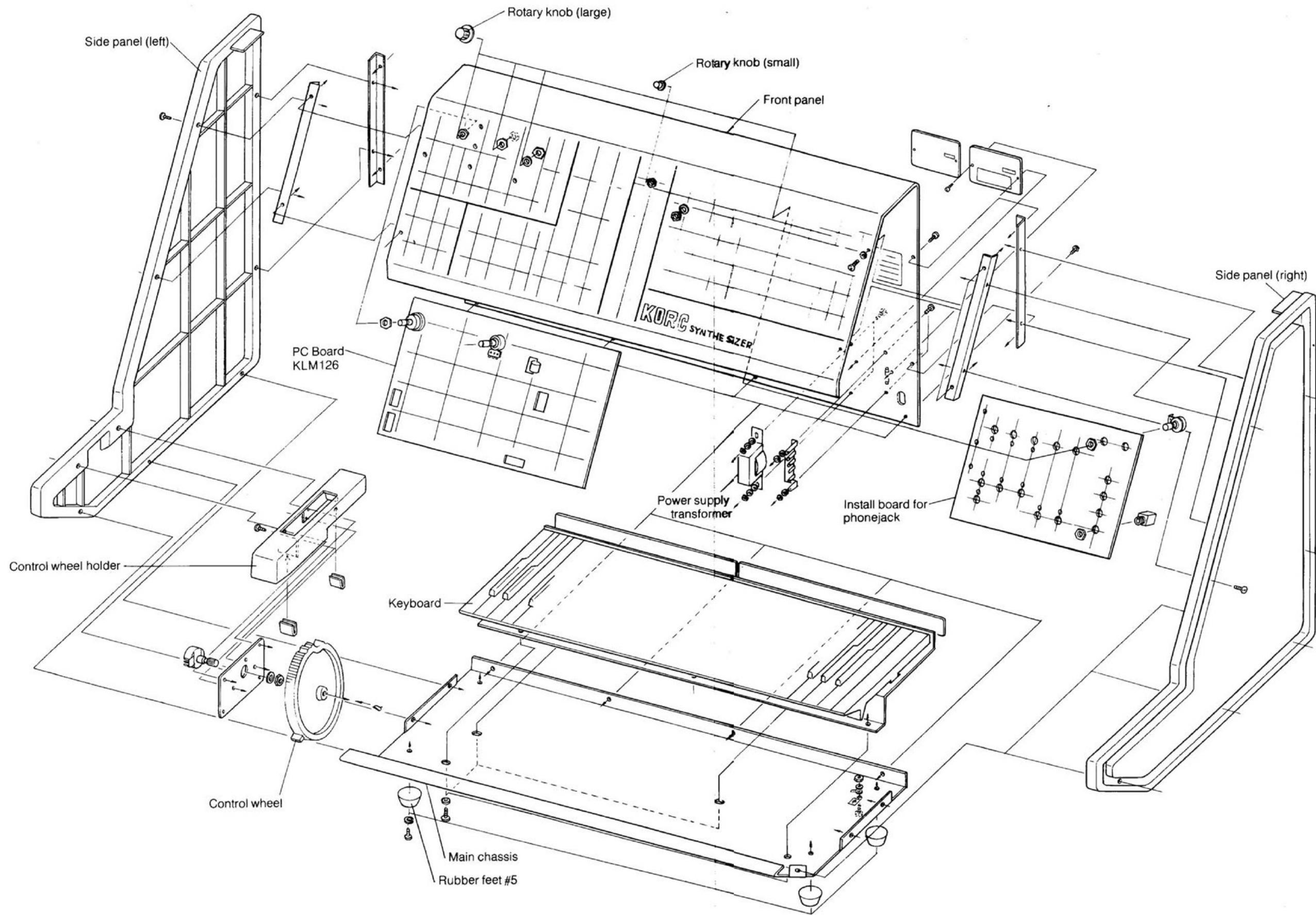

3. CIRCUIT DIAGRAM

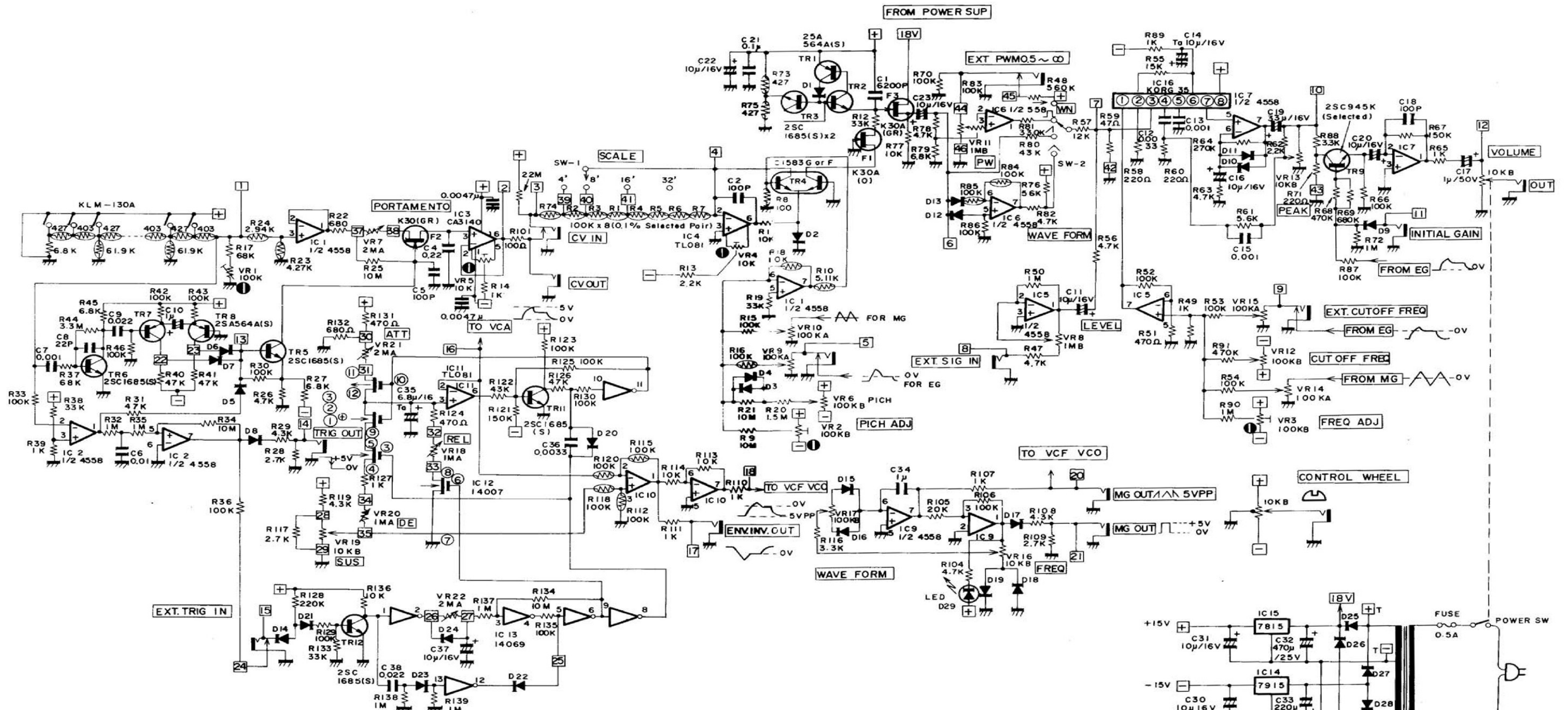

NOISE CIRCUIT NO.2 (SERIAL NO.132828 ~)

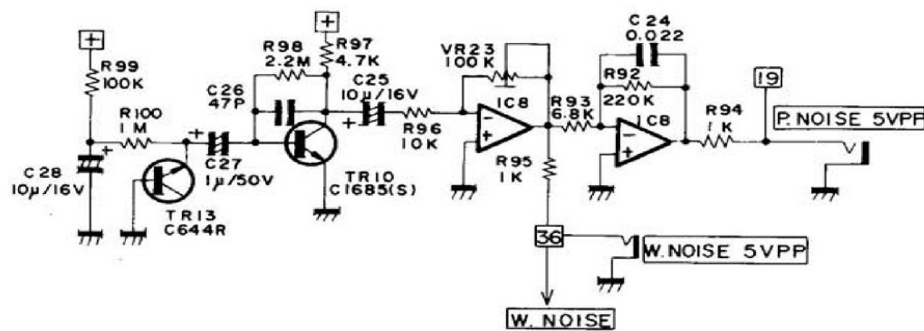

NOISE CIRCUIT NO.1 (SERIAL NO.130000 ~ 132827)

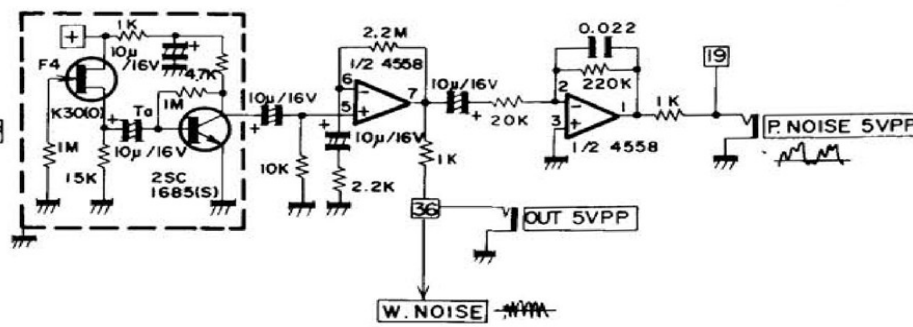

4. PRINTED CIRCUIT BOARD KLM-126B

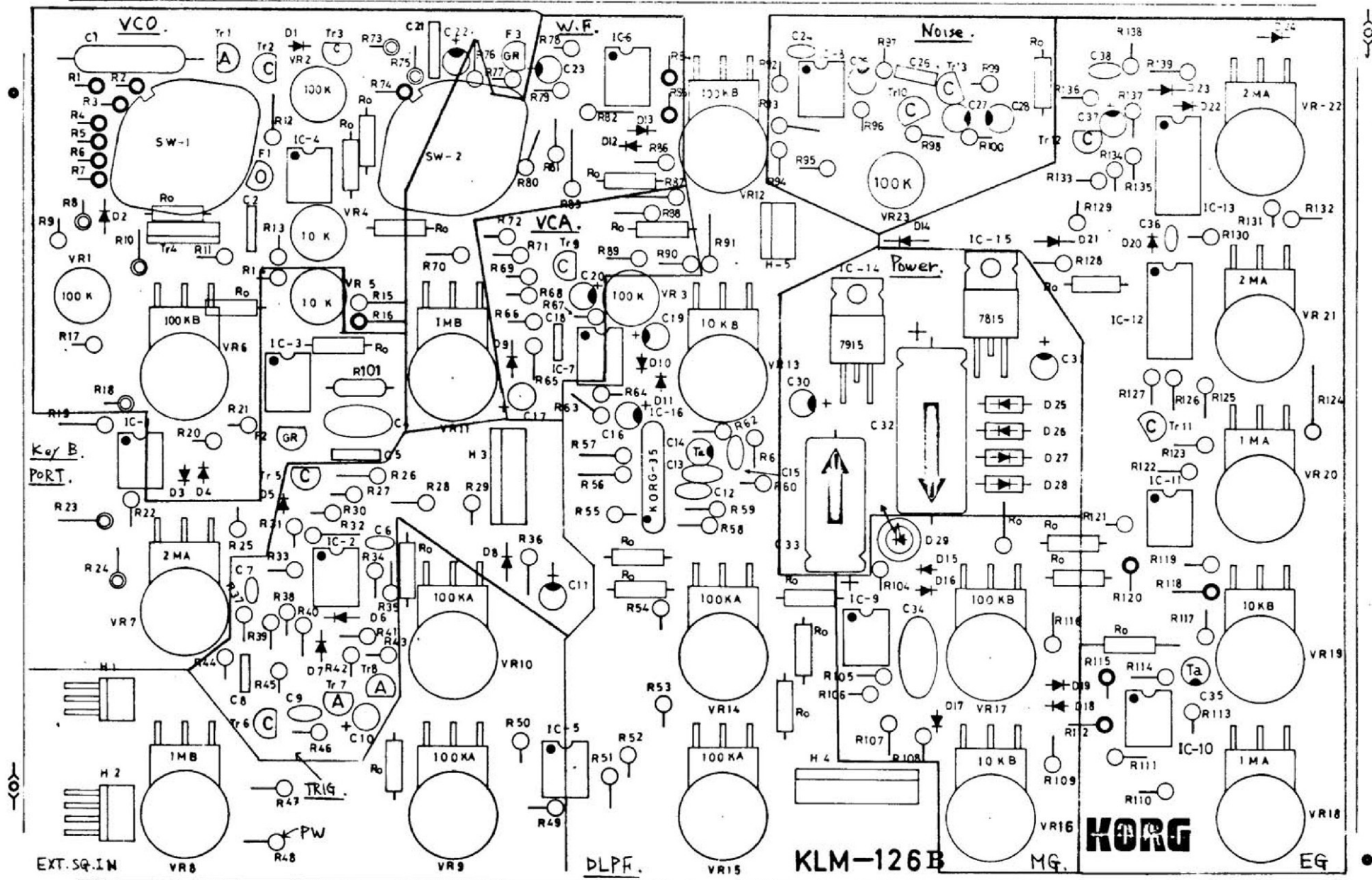

5. PARTS LIST

(Mechanical parts not listed)

<p>● CARBON RESISTORS not listed</p> <p>● METAL FILM RESISTORS</p> <p>1/4W-100Ω x 1</p> <p>1/4W-403Ω x 16</p> <p>1/4W-427Ω x 16</p> <p>1/4W-2.94kΩ x 1</p> <p>1/4W-4.27kΩ x 1</p> <p>1/4W-5.11kΩ x 1</p> <p>1/4W-61.9kΩ x 15</p> <p>1/4W-100kΩ x 15</p> <p>1/4W-110kΩ x 1</p> <p>● MYLAR CAPACITORS</p> <p>50V-0.001μF x 3</p> <p>50V-0.0033μF x 2</p> <p>50V-0.01μF x 1</p> <p>50V-0.022μF x 3</p> <p>● TANTALUM CAPACITORS</p> <p>16V-6.8μF x 1</p> <p>16V-10μF x 1</p> <p>● CERAMIC CAPACITORS</p> <p>25V-0.1μF x 1</p> <p>50V-22pF x 1</p> <p>50V-47pF x 1</p> <p>50V-100pF x 3</p> <p>50V-560pF x 1</p> <p>● ELECTROLYTIC CAPACITORS</p> <p>16V-10μF x 10</p> <p>16V-33μF x 1</p> <p>50V-1.0μF x 2</p> <p>50V-470μF x 1</p>	<p>● POLYPROPYLENE CAPACITORS</p> <p>200V-0.22μF x 1</p> <p>● POLYSTYRENE CAPACITORS</p> <p>50V-6200pF x 1</p> <p>● POLYESTER CAPACITORS</p> <p>100V-1μF x 1</p> <p>● TRANSISTORS</p> <p>2SA-564A(S) x 3</p> <p>2SC-644(R) x 1</p> <p>2SC-945(L)K x 1</p> <p>(special selected)</p> <p>2SC-1583G x 1</p> <p>2SC-1685S x 7</p> <p>● FET</p> <p>2SA-30A(O) x 1</p> <p>2SA-30A(RG) x 2</p> <p>● DIODES</p> <p>1S-1555 x 24</p> <p>1S-1885 x 4</p> <p>● LED</p> <p>GD-4-203RD x 1</p> <p>● IC</p> <p>KORG35 x 1</p> <p>MC14007 x 1</p> <p>μPC4558 x 8</p> <p>μA7815 x 1</p> <p>CA3140 x 1</p> <p>TL081(071) x 2</p> <p>μA7915 x 1</p> <p>MC14069B x 1</p> <p>● SEMI-FIXED RESISTORS</p> <p>SR19DS 10kΩ x 2</p> <p>SR19DS 100kΩ x 4</p>	<p>● ROTARY VARIABLE RESISTORS</p> <p>EVH-5LA802B15 x 3</p> <p>EVH-5LA802B14 x 3</p> <p>EVH-5LA802A15 x 4</p> <p>EVH-5LA802A16 x 2</p> <p>EVH-5LA802B16 x 2</p> <p>EVH-5LA802A26 x 3</p> <p>EVC-BQ5P18B14 x 1</p> <p>RJAP20B14 x 1</p> <p>● ROTARY SWITCH</p> <p>SRM-103420P x 2</p> <p>● KEY</p> <p>F-E 32 key x 1</p> <p>● CONNECTORS</p> <p>BE4P-SHF-1 x 1</p> <p>BE7P-SHF-1 x 1</p> <p>BE9P-SHF-1 x 1</p> <p>BS3P-SHF-1 x 1</p> <p>BS4P-SHF-1 x 1</p> <p>Female Connectors</p> <p>3P MS-1002 x 1</p> <p>4P MS-1003 x 1</p> <p>4P MS-1004 x 1</p> <p>7P MS-1005 x 1</p> <p>9P MS-1006 x 1</p> <p>MLR-03TRC-1 x 1</p> <p>MLR-03TRC-150 x 1</p> <p>● PHONE JACKS</p> <p>2P SG-7501 x 11</p> <p>2P SG-7615 x 5</p> <p>● PC BOARD</p> <p>KLM-130A x 1</p> <p>KLM-126B x 1</p>
--	--	--

6. BLOCK DIAGRAM

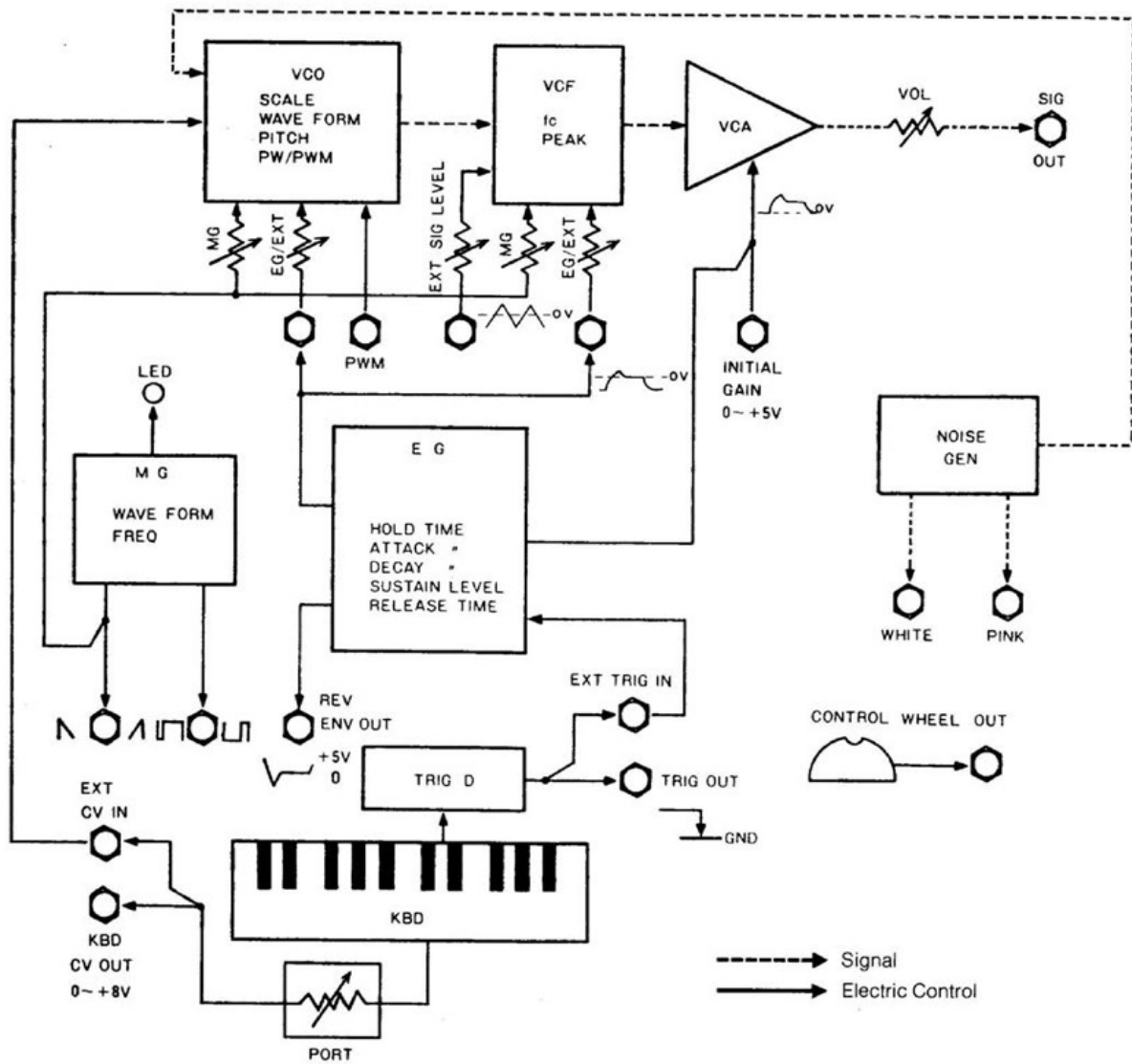

7. ADJUSTMENT PROCEDURE

7-1 Power supply check

1. Positive ripple.
Should be no more than 2mVp-p.
Set oscilloscope vertical gain at 10mV/cm and check that power supply ripple is 2mV or less.

2. Negative ripple.
Same as positive, should be no more than 2mVp-p.

7-2 Pitch adjustment

1. VCO-1.
Perform adjustment with synthesizer controls at "normal setting" (Scale=8, Waveform = □, Master Tune, Pitch, and all other knobs at "0"). See figure 1.
 - a. Play C-3 (high C) on the keyboard and adjust the high ① semi-fixed screw until you obtain the correct tuning as indicated by WT-10A (connected to the SIG OUT jack).
 - b. Play key C-1 and adjust the low ② semi-fixed screw.
 - c. Repeat steps a and b as many times as necessary until both are tuned to the correct pitch.

- d. Check the tuning of C-1, C-2, and C-3 on the WT-10A meter to make sure pitch deviation is with ± 2 cents for each.
- e. Change the scale to 32', 16', 8', and 4' and check the tuning of all four C keys to make sure that the pitch deviation of each is within ± 10 cents.

7-3 KBD CV adjustment

Use a 4-1/2 digital voltmeter to measure the KBD CV OUT signal.

- a. Measure output voltage first when you play key C-3, then when you play key C-2. The output voltage for C-3 should be exactly half that for C-3. Adjust the KBD CV high ③ semi-fixed screw as necessary so that C-2 produces half the voltage of C-3.
- b. Measure C-2 and then C-1 in the same way. Adjust the KBD CV low ④ semi-fixed screw as necessary so that C-2 produces exactly half the voltage of C-3.
- c. Repeat steps a and b as many times as necessary until the output voltage of each of C-1, C-2, and C-3 is exactly half that of the next.

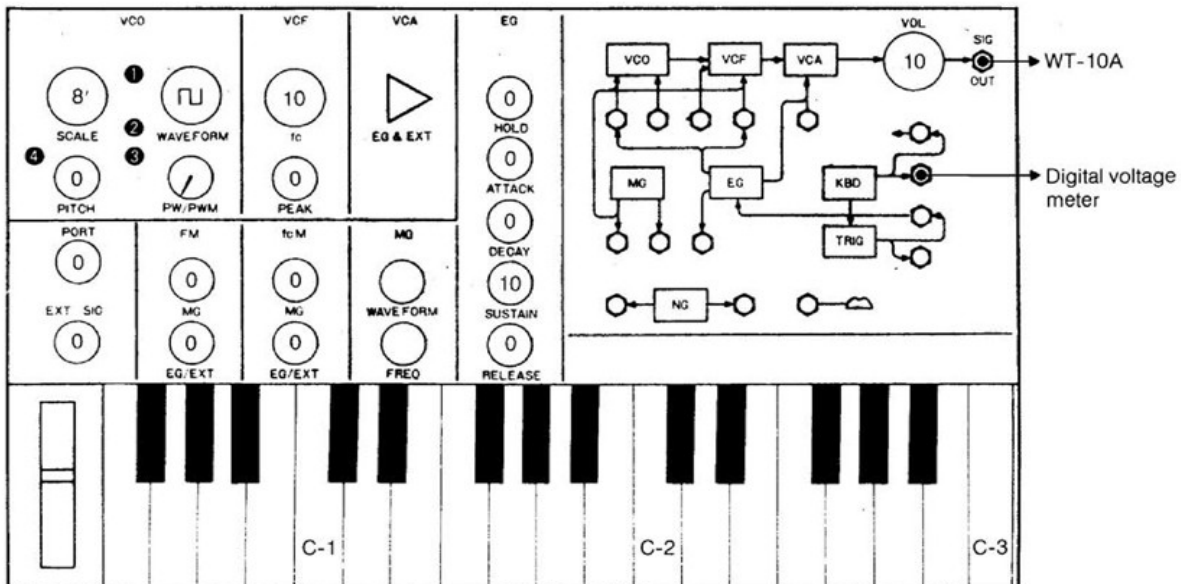

Fig. 1

7-4 VCF Fc adjustment

Connect a frequency counter to the Sig out jack.

1. VCLPF

Refer to the settings shown in figure 2. Set the Fc knob at "5", and the LPF PEAK knob at "10".

Then adjust the ① semi-fixed screw as necessary so that the LPF oscillation frequency is 500Hz.

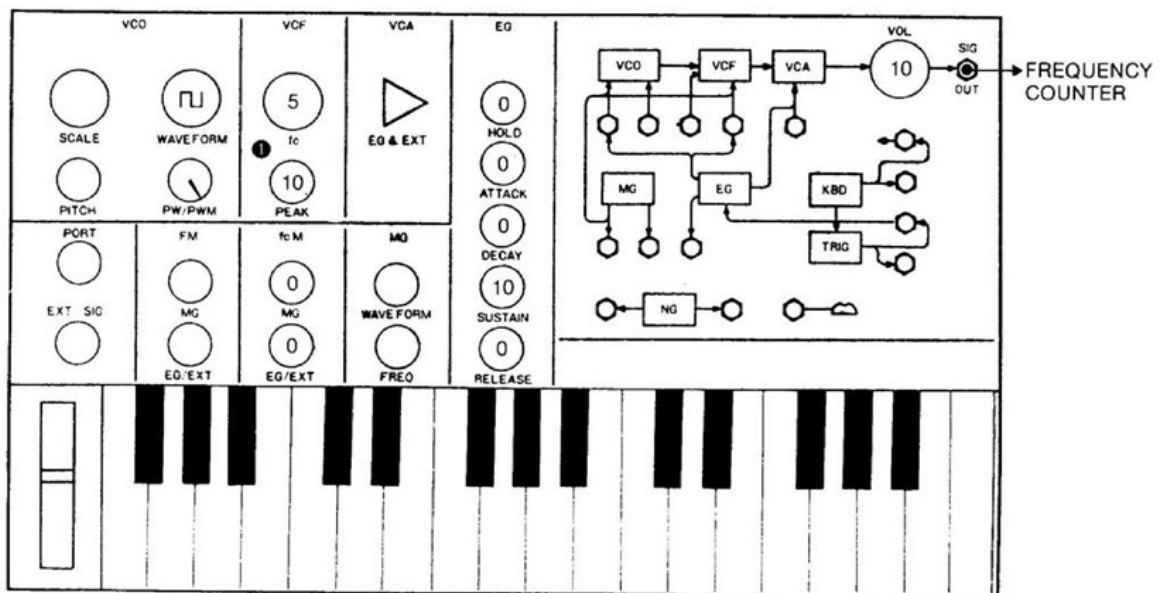

Fig. 2