

# SP2X

## *Service Manual*

**KURZWEIL**  
*Music Systems*

2007 All rights reserved. Kurzweil is a product line of Young Chang Co.; Kurzweil is a trademark of Young Chang Co. All other products and brand names are trademarks or registered trademarks of their respective companies. Product features and specifications are subject to change without notice.

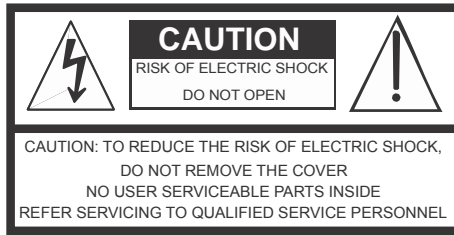

The lightning flash with the arrowhead symbol, within an equilateral triangle is intended to alert the user to the presence of uninsulated "dangerous voltage" within the product's enclosure that may be of sufficient magnitude to constitute a risk of electric shock to persons.



The exclamation point within an equilateral triangle is intended to alert the user to the presence of important operating and maintenance (servicing) instructions in the literature accompanying the product.

# IMPORTANT SAFETY & INSTALLATION INSTRUCTIONS

## INSTRUCTIONS PERTAINING TO THE RISK OF FIRE, ELECTRIC SHOCK, OR INJURY TO PERSONS

**WARNING:** When using electric products, basic precautions should always be followed, including the following:

1. Read all of the Safety and Installation Instructions and Explanation of Graphic Symbols before using the product.
2. Do not use this product near water—for example, near a bathtub, washbowl, kitchen sink, in a wet basement, or near a swimming pool, or the like.
3. This product should be used only with a stand or cart that is recommended by the manufacturer.
4. This product, either alone or in combination with an amplifier and speakers or headphones, may be capable of producing sound levels that could cause permanent hearing loss. Do not operate for a long period of time at a high volume level or at a level that is uncomfortable. If you experience any hearing loss or ringing in the ears, you should consult an audiologist.
5. The product should be located so that its location or position does not interfere with its proper ventilation.
6. The product should be located away from heat sources such as radiators, heat registers, or other products that produce heat.
7. The product should be connected to a power supply only of the type described in the operating instructions or as marked on the product.
8. This product may be equipped with a polarized line plug (one blade wider than the other). This is a safety feature. If you are unable to insert the plug into the outlet, contact an electrician to replace your obsolete outlet. Do not defeat the safety purpose of the plug.
9. The power supply cord of the product should be unplugged from the outlet when left unused for a long period of time. When unplugging the power supply cord, do not pull on the cord, but grasp it by the plug.
10. Care should be taken so that objects do not fall and liquids are not spilled into the enclosure through openings.
11. The product should be serviced by qualified service personnel when:
  - A. The power supply cord or the plug has been damaged;
  - B. Objects have fallen onto, or liquid has been spilled into the product;
  - C. The product has been exposed to rain;
  - D. The product does not appear to be operating normally or exhibits a marked change in performance;
  - E. The product has been dropped, or the enclosure damaged.
12. Do not attempt to service the product beyond that described in the user maintenance instructions. All other servicing should be referred to qualified service personnel.
13. **WARNING:** Do not place objects on the product's power supply cord, or place the product in a position where anyone could trip over, walk on, or roll anything over cords of any type. Do not allow the product to rest on or be installed over cords of any type. Improper installations of this type create the possibility of a fire hazard and/or personal injury.

## RADIO AND TELEVISION INTERFERENCE

**WARNING:** Changes or modifications to this instrument not expressly approved by Young Chang could void your authority to operate the instrument.

**IMPORTANT:** When connecting this product to accessories and/or other equipment use only high quality shielded cables.

**NOTE:** This instrument has been tested and found to comply with the limits for a Class A digital device, pursuant to Part 15 of the FCC Rules. These limits are designed to provide reasonable protection against harmful interference when the instrument is used in a commercial environment. This instrument generates, uses, and can radiate radio frequency energy and, if not installed and used in accordance with the instruction manual, may cause harmful interference to radio communications. Operation of this instrument in a residential area is likely to cause harmful interference, in which case the user will be required to correct the interference at his or her own expense.

Changes and modifications not expressly approved by the manufacturer

or registrant of this instrument can void the user's authority to operate this instrument under Federal Communications Commission rules.

In order to maintain compliance with FCC regulations, shielded cables must be used with this instrument. Operation with unapproved equipment or unshielded cables is likely to result in harmful interference to radio and television reception.

### NOTICE

This apparatus does not exceed the Class A limits for radio noise emissions from digital apparatus set out in the Radio Interference Regulations of the Canadian Department of Communications.

### AVIS

Le présent appareil numérique n'émet pas de bruits radioélectriques dépassant les limites applicables aux appareils numériques de la class A prescrites dans le Règlement sur le brouillage radioélectrique édicté par le ministère des Communications du Canada.

## SAVE THESE INSTRUCTIONS



## Young Chang Distributors

Contact the nearest Young Chang office listed below to locate your local Young Chang/Kurzweil representative.

### **Kurzweil Headquarters**

9FL, 102-Dong, I' PARK, Jeongja-Dong,  
Buandan-Gu, Seongnam-Si, Gyeonggi-Do, Korea

463-859

Tel : 1-82-31-786-7900

Fax : 1-82-31-785-2703

Web : [www.yapiano.co.kr](http://www.yapiano.co.kr)

### **YCNA(Young Chang North America)**

19060 S Dominguez Hills, Dr Rancho Dominguez,  
CA 90220, U.S.A

Tel : 1-310-637-2000

Fax : 1-310-637-2025

Web : [www.youngchang.com](http://www.youngchang.com)

### **YCRDI(Young Chang R&D Institute)**

1432 Main Street Waltham, MA02451, U.S.A

Tel : 1-781-890-2929

Fax : 1-781-890-2014

Web : [www.kurzweilmusicsystems.com](http://www.kurzweilmusicsystems.com)

# Contents

<b>CHAPTER 1 INTRODUCTION.....</b>	<b>1</b>
Introduction to SP2X.....	2
SP2X Rear Panel .....	2
Rear Panel Features.....	2
SP2X Front Panel.....	3
Front Panel Features .....	3
<b>CHAPTER 2 DIAGNOSTICS.....</b>	<b>6</b>
Diagnostic Tests .....	6
Entering Diagnostics .....	7
Diagnostic Test Modes.....	8
Run One Test .....	8
Run Burn-in.....	8
Test Results .....	8
Description of Tests.....	9
ROM .....	9
RAM .....	9
Delay RAM.....	9
Sine Wave.....	10
MIDI.....	10
NVRAM.....	10
<b>CHAPTER 3 DISASSEMBLY/ASSEMBLY .....</b>	<b>11</b>
Introduction .....	11
Cables, Connectors.....	11
Opening the SP2X.....	12
SP2X Bottom.....	12
Removing the Top Enclosure.....	14
Replacing the Top Enclosure .....	16
Closing the SP2X.....	16
Top Enclosure.....	17
Removing the Connector Board .....	18
Removing the Front Panel Board .....	19
Removing the Mod Wheel Assembly.....	20
Replacing the Mod Wheel Assembly .....	21
SP2X Keyboard Assembly .....	22
Removing the SP2X Keyboard Assembly.....	22
Replacing the SP2X Keyboard Assembly.....	23
<b>CHAPTER 4 TROUBLESHOOTING .....</b>	<b>24</b>
Introduction .....	24
Cables, Connectors.....	24
Boot Block.....	25
Entering the Boot Block .....	25
Resets.....	26
Hard Reset .....	26
Software Updates.....	26
File Formats.....	26
Replacing the Battery .....	27
SP2X Scanner Test.....	29
Power Problems.....	31
Dead.....	31

---

Audio Problems .....	31
No Audio .....	31
Front Panel Problems.....	31
Buttons, Knobs or Controllers not working.....	31
Keyboard Problems.....	31
Dead Keyboard.....	31
SP2X Interconnect Diagram .....	33
<b>CHAPTER 5 PARTS LISTS .....</b>	<b>34</b>
Introduction .....	34
SP2X PCB and Assemblies .....	34
Final Assembly.....	35
Engine Board, N012131702.....	36
Pitch and Mod Assembly, N012300063.....	39
Connector Board, N012131802.....	40
<b>CHAPTER 6 SCHEMATICS.....</b>	<b>45</b>

# Chapter 1

## Introduction

This chapter provides the service technician with a layout of the front and rear panel features, as well as a brief explanation of their functions. For in-depth descriptions of the many features the SP2X instruments include, consult the Musician's Guide.

This chapter also includes a description the symbols used throughout this manual.



**Note:** If possible, all user programs and setups should be saved prior to opening the unit, entering the Boot Block to run diagnostics or to perform a hard reset. For instructions to save all user programs and setups, see *Saving User Data in Chapter 5, page 25*.

### Notes, Cautions, Warnings

Please pay special attention to all Notes, Cautions, and Warnings used throughout this manual. A brief description of these symbols follows:



**Note:** Provides additional information emphasizes specific instructions.



**Caution:** Instructs you to proceed cautiously so that damage does not occur to the unit or individual components.



**Warning:** Alerts you so that damage does not occur to yourself, others, or external devices.

# Introduction to SP2X

## SP2X Rear Panel

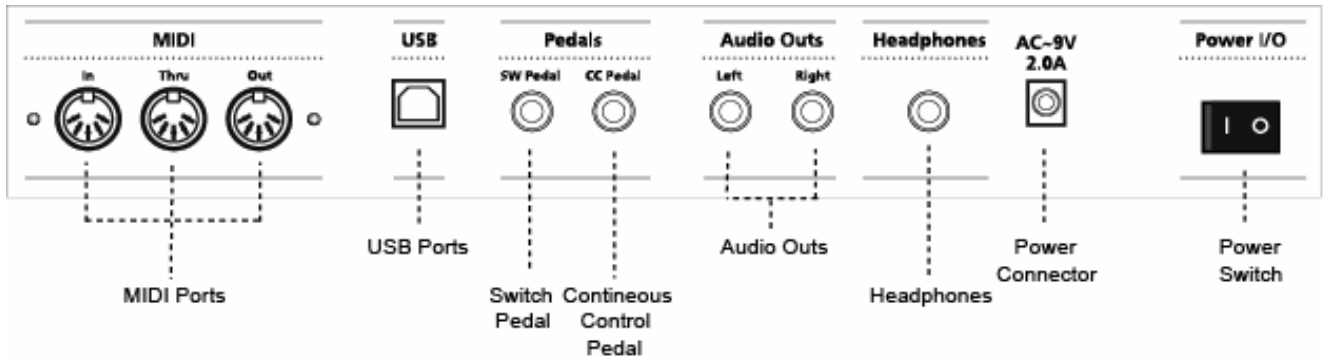

Figure 1-1 SP2X rear panel features

## Rear Panel Features

**Power Switch**—Rocker switch to turn the power on and off.

**Power Connector**—DC jack to attach the Kurzweil 9VAC power adapter.

**Headphones**—Standard 1/4" jack to connect headphones.

**Audio Outs**—Balanced 1/4" left and right audio output jacks to connect to an amplifier, mixer or sound system

**Switch Pedal(SW Pedal)**— One 1/4" jacks to connect switch pedals that can be assigned to control operations such as sustain, sostenuto, etc. (use 1/4" tip/sleeve).

**Continuous Control Pedal(CC Pedal)**—One 1/4" jacks to connect pedals that can be assigned to control operations such as volume, expression, etc. (use 10K $\Omega$  linear taper potentiometer, 1/4" tip/ring/sleeve).

**MIDI Ports**—In, Thru/Out, and Out ports to connect the SP2X to other MIDI devices to receive, pass, and send MIDI data.

**USB Port**—Transmit/receive MIDI messages over USB with host system(typically, PC).



# SP2X Front Panel

Figure 1-2 is an illustration of the front panel for the SP2X. Enlargements of sections of this illustration follow, as well as a brief description of the front panel features.

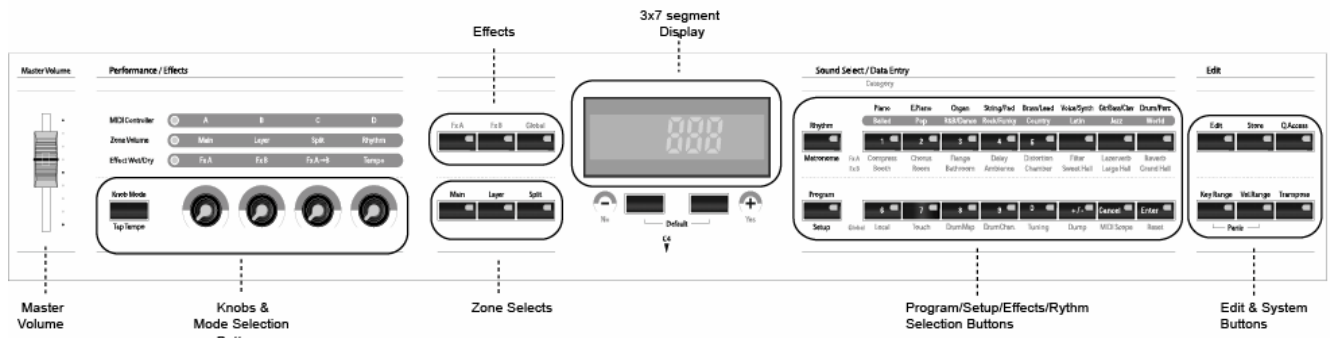

Figure 1-2 SP2X Front Panel layout

## Front Panel Features

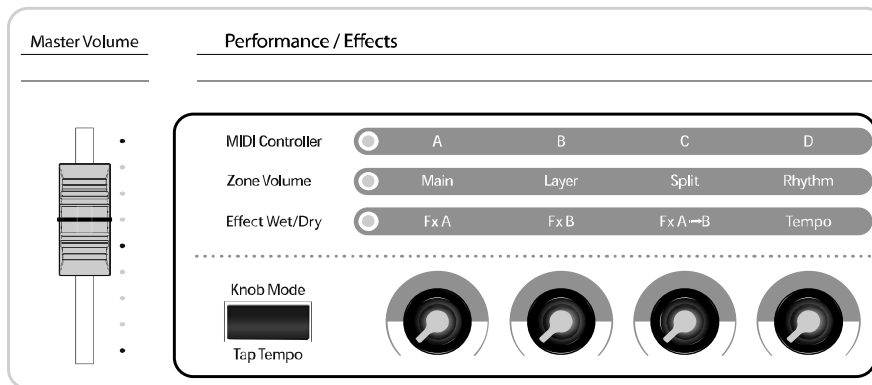

Figure 1-3 Master Volume, Performance, and Effects section

**Master Volume**—Slidepot to adjust the overall volume.

**Performance and Effects**—The operation of the buttons and knobs in this section depends on which of the three performance modes is active. Each LEDs located top of the **Knob Mode** selection button shows current one of performance modes. They are labeled as follows: MIDI Controller mode, Zone Volume mode, Effects Wet/Dry mode.



**Figure 1-4 SP2X Front Panel, center section**

**3X7 Segment**—Three-character, 7 segment display.

**+/- Buttons**—This button can change Sounds in Program/Setup mode and also used as “Play” and “Stop” button while playing demo song or rhythm pattern. In Global or Boot block menu can scroll menu items with this button.

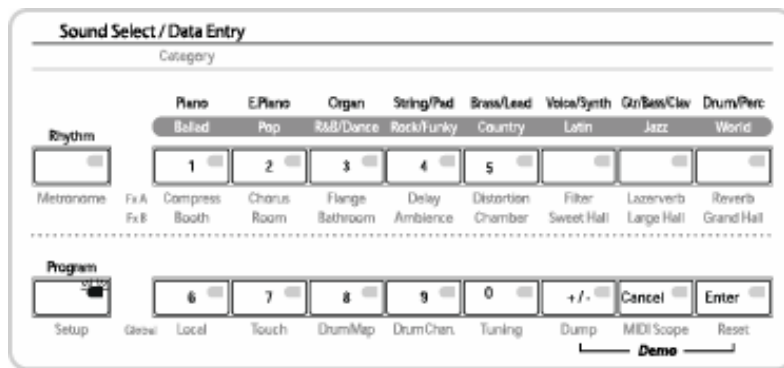

**Figure 1-5 Sound Select / Data Entry sections**

**Group Select**—Use the buttons to select a category of Programs or Setups.

**Effects and Reverb** – Use the buttons to select from two blocks of effects to apply effects and reverb to programs and setups.

**Program/Setup Select**—Use the button labeled 1–0, to select a specific program or setup. These buttons also used as keypad when you enter numbers. +/- button can change sign of the number typed in keypad mode. Enter/Cancel buttons used as enter or cancel the values you typed in keypad mode.

**Mod/Pitch Wheel Assembly**(not shown)—Use the two wheels to vary modulation and pitch.

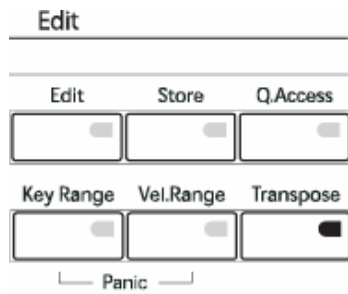

**Figure 1-6 Edit sections**

**Edit/Store** – Use this button to edit/store modified program or MIDI setup to user bank.

**Q.Access** – Use this button add your favorite Program/Setup in one place for easy and fast access.

**Key/Vel. Range** – Use this button change Key or Velocity rages

**Transpose** – Use this button to change tonality, using +/- button can be up/down up to 2 octaves.

# Chapter 2

## Diagnostics

### Diagnostic Tests

The following lists the diagnostic tests available for the SP2X.

- ROM
- RAM
- MARA
- Sound ROM
- DRAM
- Sine
- MIDI
- NVRAM



**Warning:** Some diagnostic tests erase user programs and setups. If possible, be sure to save all user programs and setups, before entering diagnostics. For instructions, refer to *Saving User Data* in Chapter 5, page 25.

## Entering Diagnostics

Apply power to the unit. Press **Transpose** button one time while three dots blinking in the 7-segment. After a while, segment display the following message:



Figure 2-1 7-segment example, entering diagnostics



Press either the **Yes** or **No** button until  appears in the segment. Press the **Rhythm** button for enter into menu item. The segment displays the following:

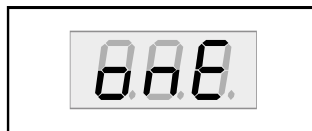

Figure 2-2 7-segment example, diagnostic main menu

Press **Rhythm** to select the run one test mode. To select the run burn-in test mode, press either the **Yes** or **No** button then press the **Rhythm** button to begin the tests.

## Diagnostic Test Modes

### Run One Test

Run One Test allows you to select an individual test, or to step through and run each available test. To step through the different tests, the **Yes** or **No** button. Press the **Rhythm** button to select the test.



**Figure 2-3 7-segment example, Run One Test**

At the completion of a test, whether pass or fail, press the **Program** button to exit the test. Press either the **Yes** or **No** button to advance to the next test or another test in the sequence.

At the completion of a test, press the **Program** button to return to the test menu. To exit diagnostics, turn the power off and on to return to normal operation.

### Run Burn-in



Burn-in mode, segment displays and following sequence of tests,.

continuously runs the

- ROM
- RAM
- MARA
- Sound ROM
- DRAM
- MIDI

The segment displays the test results at the completion of each test. To stop the burn-in process and view the test results for each test run, press the **Program** button. Use the **Yes** or **No** button to scroll through the results of each test.

To exit Run Burn-in and return to the main menu, press the **Program** button. To exit diagnostics, turn the power off and on to return to normal operation.

### Test Results

At the completion of an individual test, the segment displays the test results. An expected

result is

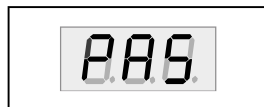

mans passed,



means failed.

## Description of Tests

### ROM



This test checks the software data (engine, boot, and setups) stored in FlashROM on the Engine Board.

A failure of this test may indicate a problem with the Flash ROM chip (U5 on the Engine Board), associated circuitry, or the Engine Board.

### RAM



The RAM test writes to the microprocessor RAM space and verifies that the write was successful. A failure of this test may indicate a problem with the RAM or related circuitry on the Engine Board.

### MARA



This test performs a read-write of the MARA registers and verifies that the data written can be read back successfully. A failure of this test may indicate a problem with a MARA, related circuitry or the Engine Board.

### Sound ROM



This test confirms that the Sound ROMs can be read by the MARAs by performing a checksum of the Sound ROMs. The computed checksum is then compared to the stored checksum. A failure of this test may indicate a problem with a Sound ROM (U47), or the Engine Board.

### Delay RAM

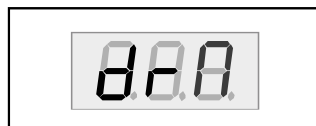

This test performs a quick read-write of the internal RAM and verifies that the data was successfully written and retained. A failure of this test may indicate a problem with the RAM or the Engine Board.

## Diagnostics

### Description of Tests

---

#### Sine Wave



This test generate sine wave from MARA, wave sample located in SoundROM, and plays through DAC and analog audio output. A failure of this test may indicate a problem with a MARA or Sound ROM (U47), or the analog audio section including DAC and OP-AMPs.



**Caution:** The output level of sinewave test is very loud!.

#### MIDI



The MIDI test performs a loop-back of the serial port by sending a 23-byte pattern over the external MIDI link. This test requires a MIDI loop (a MIDI cable that connects two MIDI jacks). The test will fail if a MIDI cable is not connected between two MIDI jacks. Be sure to run this test with MIDI cables connected as follows:

**Note:** Be sure to use a known working MIDI cable!



1. Connect a MIDI cable to the MIDI In and MIDI out jacks and run the test.

A failure of this test could be caused by failure of the serial port, other MIDI circuitry, or a problem on the Connector Board or the Engine Board.

#### NVRAM



The NVRAM(rM2) test performs part of the SRAM back up by built in lithium coin cell battery. Test starts with write test pattern to NVRAM area and after power cycle, read pattern again.

A failure of this test could be caused by low battery voltage or problem of battery-back related circuit.



# Chapter 3

## SP2X Disassembly/Assembly

### Introduction

This chapter contains all the procedures for the disassembly and reassembly of SP2X—as well as instruments with factory-installed. There are three main sections: Opening the SP2X, Top Enclosure, SP2X Keyboard Assembly.



**Warning:** If possible, save all user programs and setups before disassembly. For instructions, refer to *Saving User Data* in Chapter 5, page 25.

### Notes, Cautions, Warnings

Please pay special attention to all Notes, Cautions, and Warnings as they not only point out specific instructions.

### Cables, Connectors

#### Flat Ribbon Cables

All flat ribbon cables with connectors are keyed, and therefore cannot be reversed. Most flat ribbon cables have locking cable clips. Be sure to reapply the clips when connecting cables. When disconnecting and connecting these cables, you must look for the marking on the edge of the cable denoting Pin 1 and be sure that you match it correctly with Pin 1 on the board.

#### Cable Routing

In some cases, tape secures cable connections or fastens cables to the Top enclosure. Always peel back the tape from one side when disconnecting cables so that the tape remains properly positioned.

### Required Tools and Materials

- No. 1 Phillips head screwdriver
- No. 2 Phillips head screwdriver
- Small flat screwdriver
- Dowel (3mm diameter)
- Needle-nose pliers
- Small blunt-end tool (Q-Tip, toothpick, etc.)
- Foam block

# Opening the SP2X

## SP2X Bottom

Refer to Figure 4-1. Arrows indicate the locations of the enclosure support wall, endcap and bottom rear panel screws.

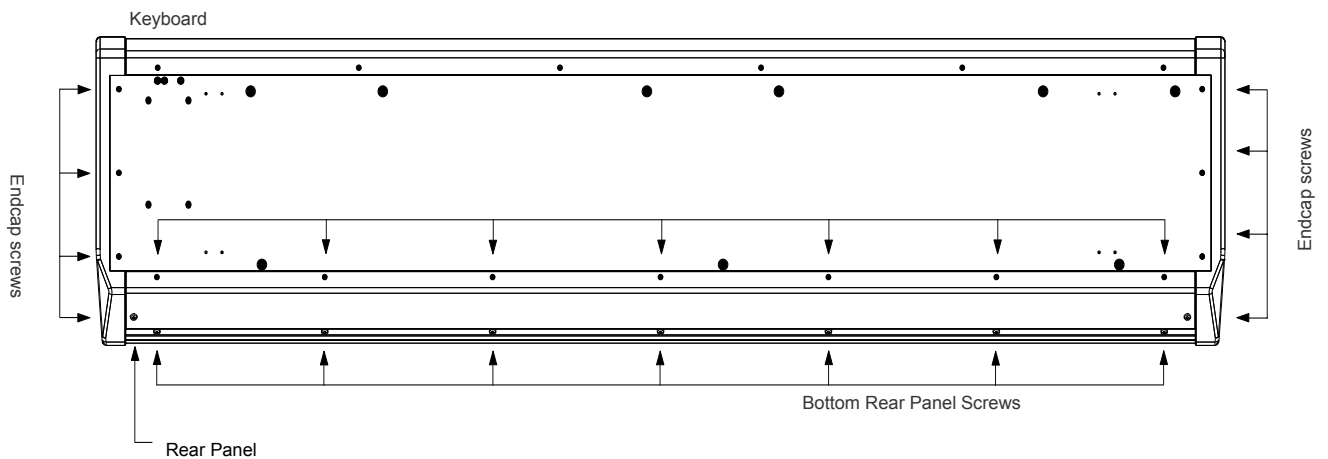
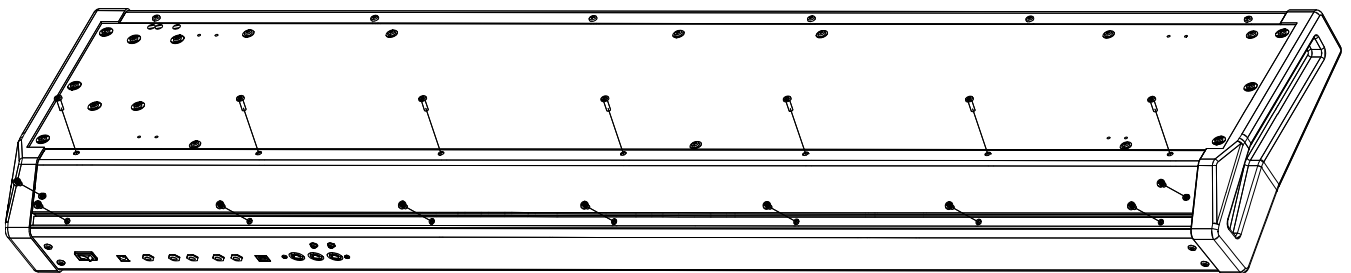

**Figure 4-1 SP2X bottom enclosure**



**Caution:** Do not remove the endcap or bottom rear panel screws at this point of the procedure.

1. Place the unit flat on your work surface.
2. Tilt the SP2X up and move the unit so that the rear panel portion of the unit hangs over the edge of your work surface. This gives you access to the fourteen screws that secure the bottom rear panel portion of the top enclosure to the bottom enclosure. Remove the fourteen screws

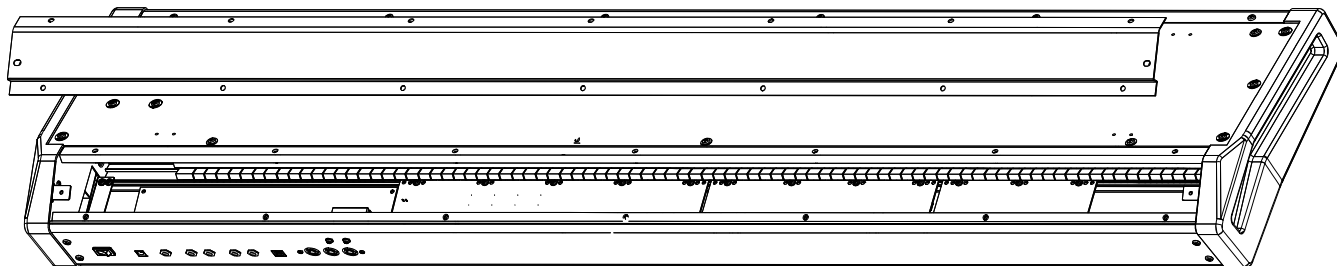

**Figure 4-2 SP2X remove bottom rear panel screw**

**SP2X Disassembly/Assembly**  
**Removing the Top Enclosure**

---

3. Refer to Figure 4-3 remove bottom-rear cover



**Figure 4-3 SP2X remove bottom rear panel**

4. Refer Figure 4-4 remove 6 keyslip locking screws.

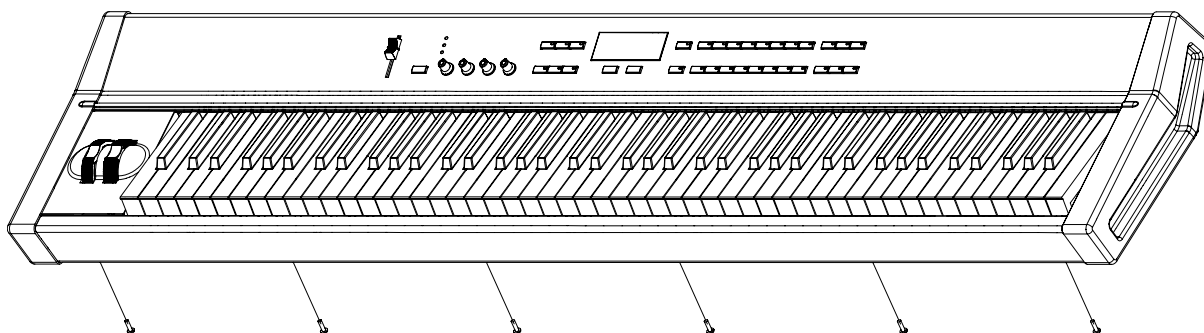

**Figure 4-4 SP2X remove keyslip screws**

5. Refer to Figure 4-5 remove keyslip from the top assembly

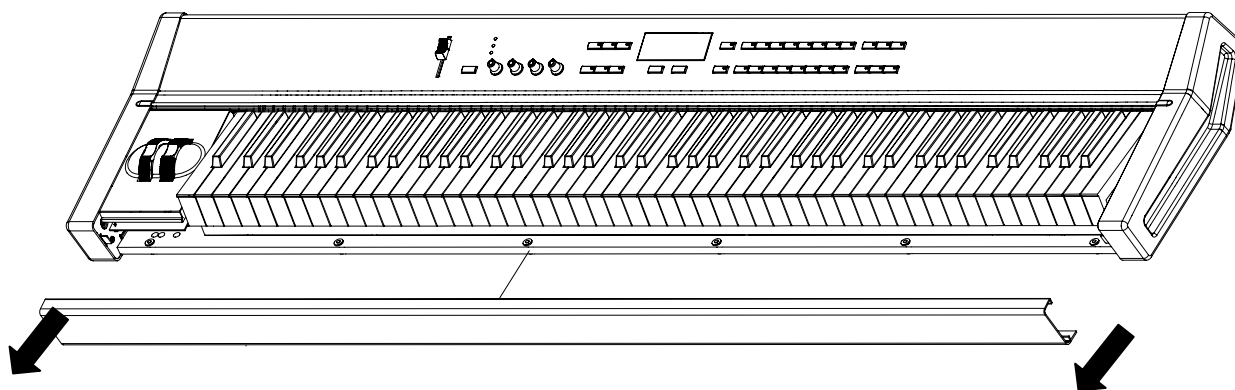

**Figure 4-5 SP2X remove keyslip from the unit**

## Removing the Top Enclosure

1. Follow the procedures described on page 14 remove bottom cover.
2. Refer to Figure 4-6.
3. Remove the six screws that secure the endcaps to the rear panel.

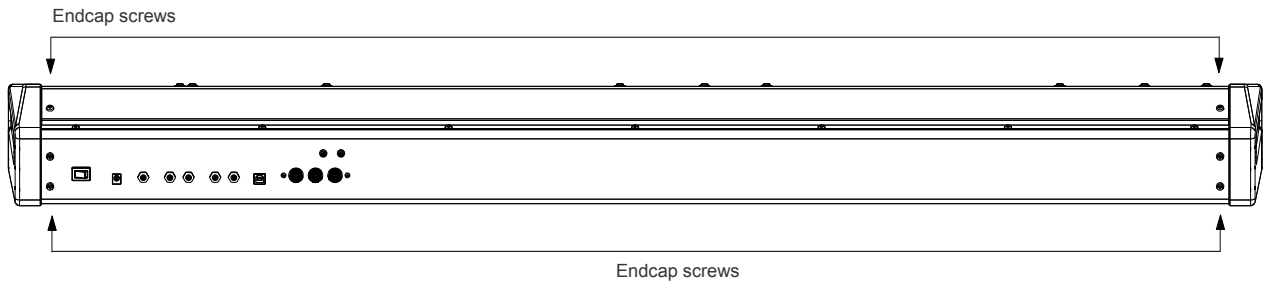
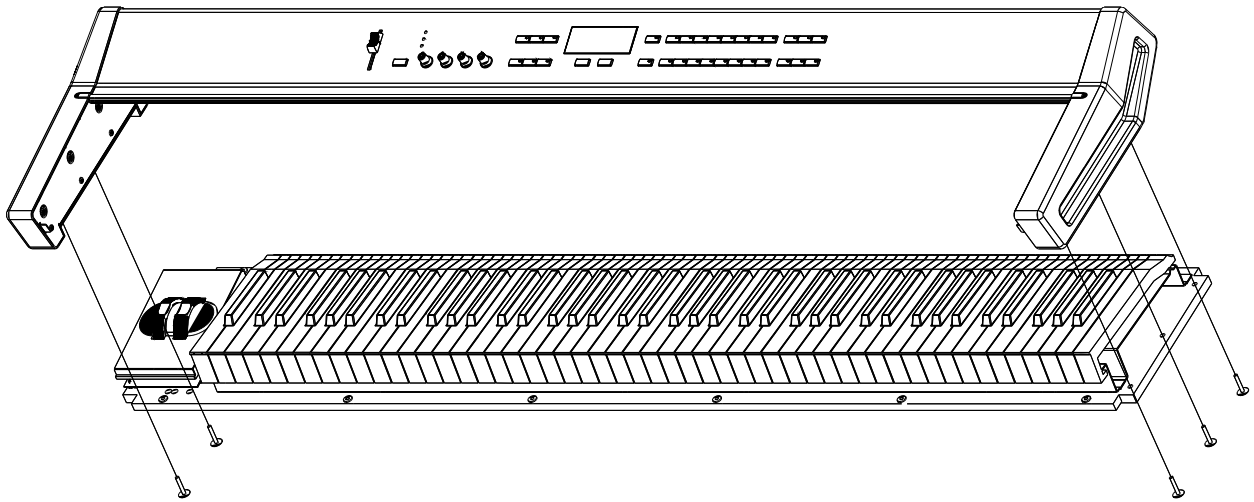

**Figure 4-6 SP2X rear panel**



**Caution:** The following steps describe removing the left and right endcaps. To avoid damage to the endcaps, be sure to hold onto each endcap when removing the screws. When the endcap screws are removed, the endcap is free of the unit.

4. Refer to Figure 4-1 for the SP2X. Move the unit so that one end hangs over the edge of your work surface. Remove the four endcap screws from the bottom enclosure.
5. Refer to Figure 4-4. The bottom edge of the rear panel and back edge of the bottom enclosure connect to form a lip. The bottom enclosure screws secure the lip.



**Figure 4-7 Top cover and bottom enclosure**

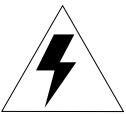

**Warning:** Be sure to have your work surface prepared. This includes placing foam blocks behind the unit. When the top enclosure is removed, place it on the foam blocks to avoid damaging the volume sliders, control panel buttons, and knobs. The following procedure requires enough room behind the rear of the unit to place the top enclosure face down on your work surface.

6. Grip each end of the top enclosure and rotate it back approximately two inches. This separates the bottom edges of the top enclosure and bottom enclosure.
7. Lift the top enclosure straight up.
8. Turn the top enclosure over and place it face down onto your work surface.



**Caution:** Table 4-1 lists the cables, by board location, from the top enclosure to the assembly they connect to on the bottom enclosure. You should disconnect these cables before removing top cover.

Top cover Assembly	Bottom Enclosure
Connector Board	Keyboard Assembly
Connector Board	Keyboard Assembly
Connector Board	Mod Wheel Assembly

**Table 4-1 Top cover and bottom enclosure cables**

## Replacing the Top Enclosure

1. Position the top enclosure behind the bottom enclosure.
2. Move the top enclosure so that the bottom edge of the rear panel is positioned under the bottom enclosure edge. See Figure 4-1 on page 13.



**Note:** Verify that the cables listed in Table 4-1 are lying flat on the bottom enclosure. Be sure that all other cables are tucked between the top enclosure.

3. Hold the top enclosure safely in place and move the unit so that one end of the bottom rear panel edge hangs over the edge of your work surface and install the bottom rear panel screw at that end. Slide the unit back onto your work surface. Repeat for other end. Refer to Figure 4-1.



**Warning:** Perform Steps 3 and 4 separately. Combining these steps could cause the top enclosure to flip away from the bottom enclosure or off of your work surface.

4. Move the unit so that the rear panel edge of the unit hangs over the edge of your work surface and install the remaining screws.

## Closing the SP2X



**Warning:** The following procedure assumes that you have completed Steps 3 and 4 in *Replacing the Top Enclosure*. If you have not completed these steps, do so before continuing.

1. Refer to Figure 4-7 for the SP2X Tilt the unit up and install screws.
2. Slide one side of the unit off of your work surface and hold the appropriate endcap in position. Install the six endcap screws in the bottom enclosure. Repeat for the other endcap.
3. Refer to Figure 4-6. Install the six endcap screws in the rear panel.

## Top Enclosure

The top enclosure includes three boards: Connector, Front Panel, and Engine. Figure 4-9 shows the placement of the boards.

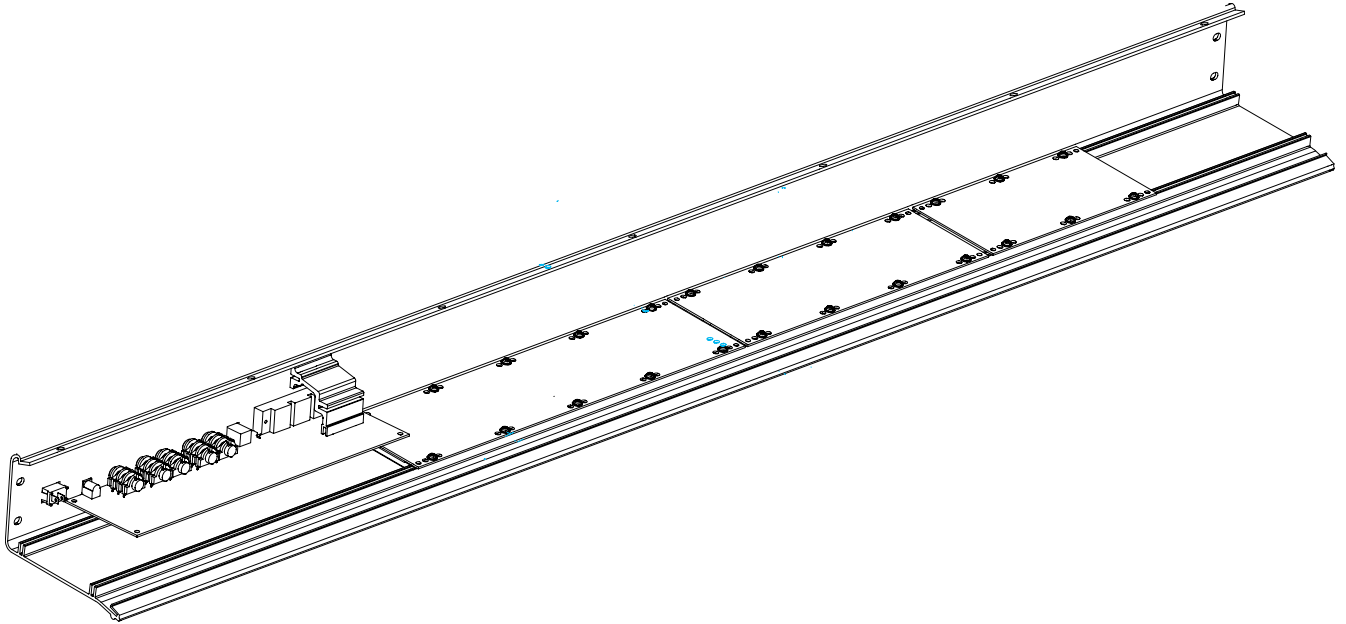

Figure 4-8 Top enclosure Assembly

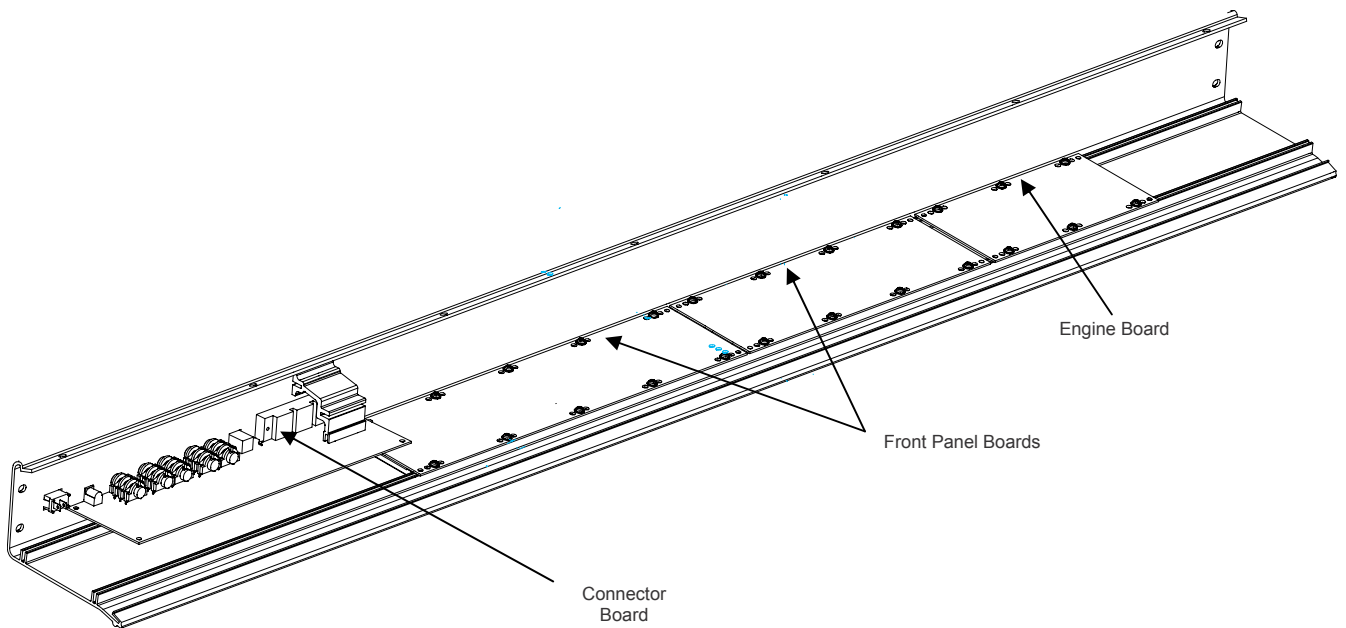

Figure 4-9 Top enclosure, board locations

## Removing the Connector Board

1. Follow the procedure described on page 16 to remove the top panel assy.
2. Following Steps 3–5, disconnect the cables listed in Table 4-2

Ref.	Name	Cable Type	Destination
J11	SP2X Power	standard wire	Engine Board
J15	Audio	standard wire	Engine Board
J4	MIDI/CPU	standard wire	Engine Board
J6	Front Panel	flat ribbon	Front Panel Board
J2	Treble	flat ribbon	Keyboard Assembly
J3	Bass	flat ribbon	Keyboard Assembly
J1	Wheels	standard wire	Mod Wheel Assembly
J20	USB	standard wire	Engine Board

**Table 4-2 Connector Board cables**

3. Disconnect the hook-up wire cable on the Connector Board.
4. Remove the cable locking clips and disconnect the flat ribbon cables from J2, J3, and J4. Be sure to set the cable locking clips safely aside so that you can install them when you reconnect the cables.



**Note:** The cables used throughout the SP2X are bundled and routed so that their locations and destinations seem obvious. However, to avoid reversing the Bass and Treble cables when reconnecting, mark one or both cables designating B for Bass and T for Treble.

5. Remove the five screws that secure the Connector Board to the rear panel. Two of these screws are longer than the others and have spacers located between the screw and the rear panel. See Figure 4-7 for the locations of the screws and spacers.



**Note:** Do not remove any other hardware from this portion of the rear panel.

6. Remove the two screws that secure the MIDI jacks to the rear panel. See Figure 4-7.
7. Remove the Connector Board.

## Replacing the Connector Board

1. Hold the Connector Board and position it so that the power switch, and the rear panel jacks are correctly positioned through the rear panel portion of the top enclosure.
2. Install the two screws that secure the MIDI jacks to the rear panel. See Figure 4-7.
3. Install the five screws that secure the Connector Board to the rear panel. Be sure to place a spacer and use one of the longer screws at the locations noted in Figure 4-7.
4. Connect the ribbon cables in the following order.



**Caution:** Be sure to look for the marking on the edge of the cable denoting Pin 1 and that you match it correctly with Pin 1 on the board. Make certain that the wires are straight prior to inserting them into the connector and that each wire is correctly inserted into its respective position.



5. Connect the flat ribbon cables from the Keyboard Assembly to J2 and J3. Be sure to install a cable locking clip on each connector.
6. Connect the flat ribbon cable from the Front Panel Board to J4 on the Connector Board. Be sure to install a cable locking clip on the connector.
7. Connect all the stranded wire cable from the Engine Board to the Connector Board and from Front board to connector board..

## Removing the Front Panel Board

1. Follow the procedure described on page 19 to remove the Connector Board.
2. Following Steps 4 and 5, disconnect the cables listed in Table 4-3.  
Top Enclosure

Ref.	Name	Cable Type	Destination
J4	FP Bridge	flat ribbon	Front Board
J5	FP Bridge	flat ribbon	Front Board

**Table 4-3 Front Panel Board cables**

3. Remove the cable locking clip and disconnect the flat ribbon cable at J4, J5 on the Front Panel Board. Be sure to set the cable locking clip safely aside so that you can install it when you reconnect the cable.
4. Remove the eighteen screws that secure the three PC board clamps
5. Remove slider volume handle and 4 control knob handles also
6. Lift the Front Panel Board up from the top enclosure.



**Caution:** Each switch button cap uses a set of small pegs to mount the cap to the Front Panel Board. The button caps are mounted individually or in clusters. If a cap becomes separated from the board, be careful that a peg is not inadvertently broken.

## Replacing the Front Panel Board

1. Position the Front Panel Board onto the top enclosure, then raise the top enclosure up slightly to verify that the volume slider and switch button caps are correctly positioned through their openings in the top enclosure.
2. Align the center screw holes of the three-hole groupings on the front panel edge of the board with the thread marks in the extrusion and install the two screws that secure the front panel edge. See Figure 4-8.
3. Connect ribbon cable cables in the following order.



**Caution:** Be sure to look for the marking on the edge of the cable denoting Pin 1 and that you match it correctly with Pin 1 on the board. Make certain that the wires are straight prior to inserting them into the connector and that each wire is correctly inserted into its respective position. connector.

4. If you have disconnected the flat ribbon cable from J4, J5, reconnect it. Be sure to install the cable locking clip.
5. Follow the procedure on page 19 to install the Connector Board.

## Removing the Engine Board

1. Following Step 2, disconnect the cables listed in Table 4-4.

Ref.	Name	Cable Type	Destination
J6	SP2X PWR	stranded wire	Connector Board
J4	MIDI & CPU	Standard wire	Connector Board
J9	SP2X Audio Out	stranded wire	Connector Board
J10	SP2X USB	standard wire	Connector Board

**Table 4-4 Engine Board cables**

2. Disconnect the stranded wire cables from J6 to J10.
3. Remove the Engine Board

## Replacing the Engine Board

1. Place the Engine Board in position on the top enclosure.
2. Align the center screw hole on the front panel edge with the thread marks in the extrusion and install the screw that secures the front panel edge. See Figure 4-9.
3. Connect the stranded wire cable from the Connector Board to on the Engine Board.



**Caution:** Be sure to look for the marking on the edge of the cable denoting Pin 1 and that you match it correctly with Pin 1 on the board. Make certain that the wires are straight prior to inserting them into the connector and that each cable is correctly inserted into its respective position.

## Removing the Mod Wheel Assembly

1. Refer to Figure 4-10. Slide the left side of the unit forward off of your work surface so that you can access the four screws and washers securing the assembly to the bottom enclosure. Remove the four screws and washers.

2. Slide the unit back onto your work surface.

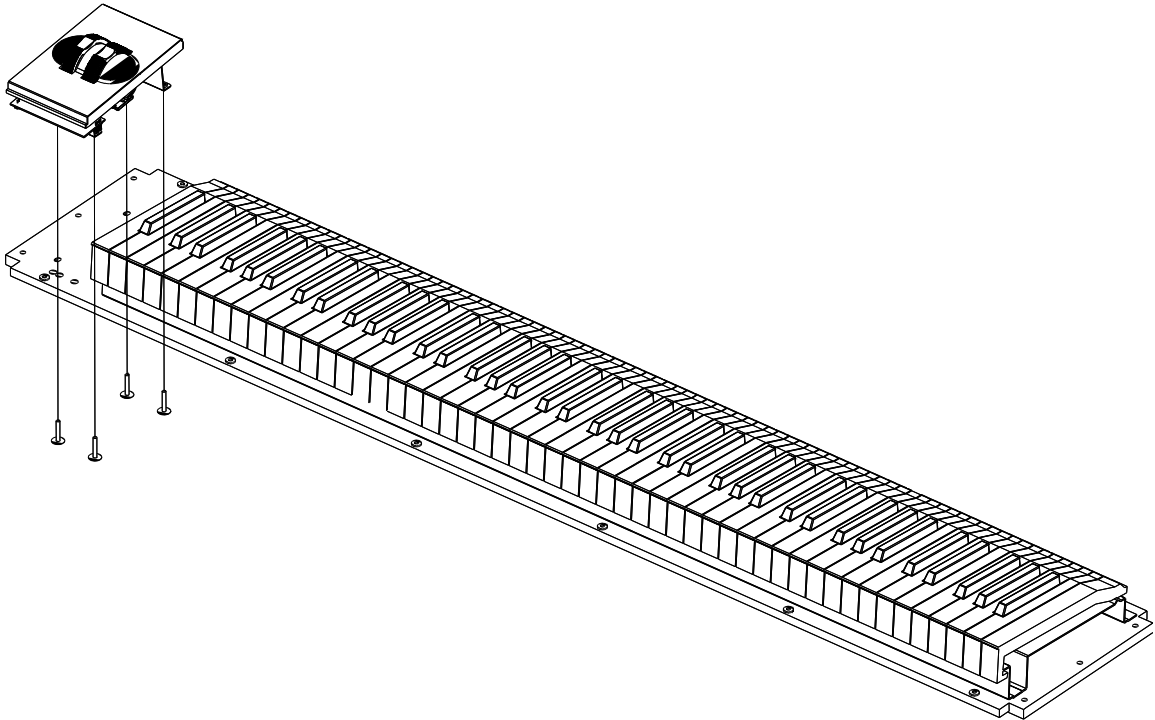

**Figure 4-10 Mod Wheel Assembly**

3. Remove the Mod Wheel Assembly.

## Replacing the Mod Wheel Assembly

1. Hold the Mod Wheel Assembly in position over the bottom enclosure.
2. Connect the standard wire cables in the following order.



**Caution:** Be sure to look for the marking on the edge of the cable denoting Pin 1 and that you match it correctly with Pin 1 on the board. Make certain that the wires are straight prior to inserting them into the connector and that each wire is correctly inserted into its respective position.

3. Connect the standard wire cable(s).
4. Reapply the nylon reinforced tape to the standard cable(s).
5. Lower the Mod Wheel Assembly into position.
6. Slide the unit forward and install the four screws and washers to secure the Mod Wheel Assembly to the bottom enclosure.

## SP2X Keyboard Assembly

### Removing the SP2X Keyboard Assembly

The following procedure assumes that the SP2X is open and that you have followed the instructions to remove the top enclosure.

1. The keyboard is secured to the bottom enclosure using nine screws. Refer to Figure 4-11 for the position of the screws. Arrows identify the locations of the nine screws.
2. Tilt the SP2X up and remove the five keyboard rear screws, then lay the SP2X flat on your work surface.
3. Move the SP2X forward so that the front hangs over the edge of your work surface to access the remaining screws, and remove the five keyboard front screws.
4. Remove the four Mod Wheel screws and washers. At this point the keyboard is loose in the bottom enclosure, but it has cables connected to the Mod Wheel Assembly and the Connector Board.

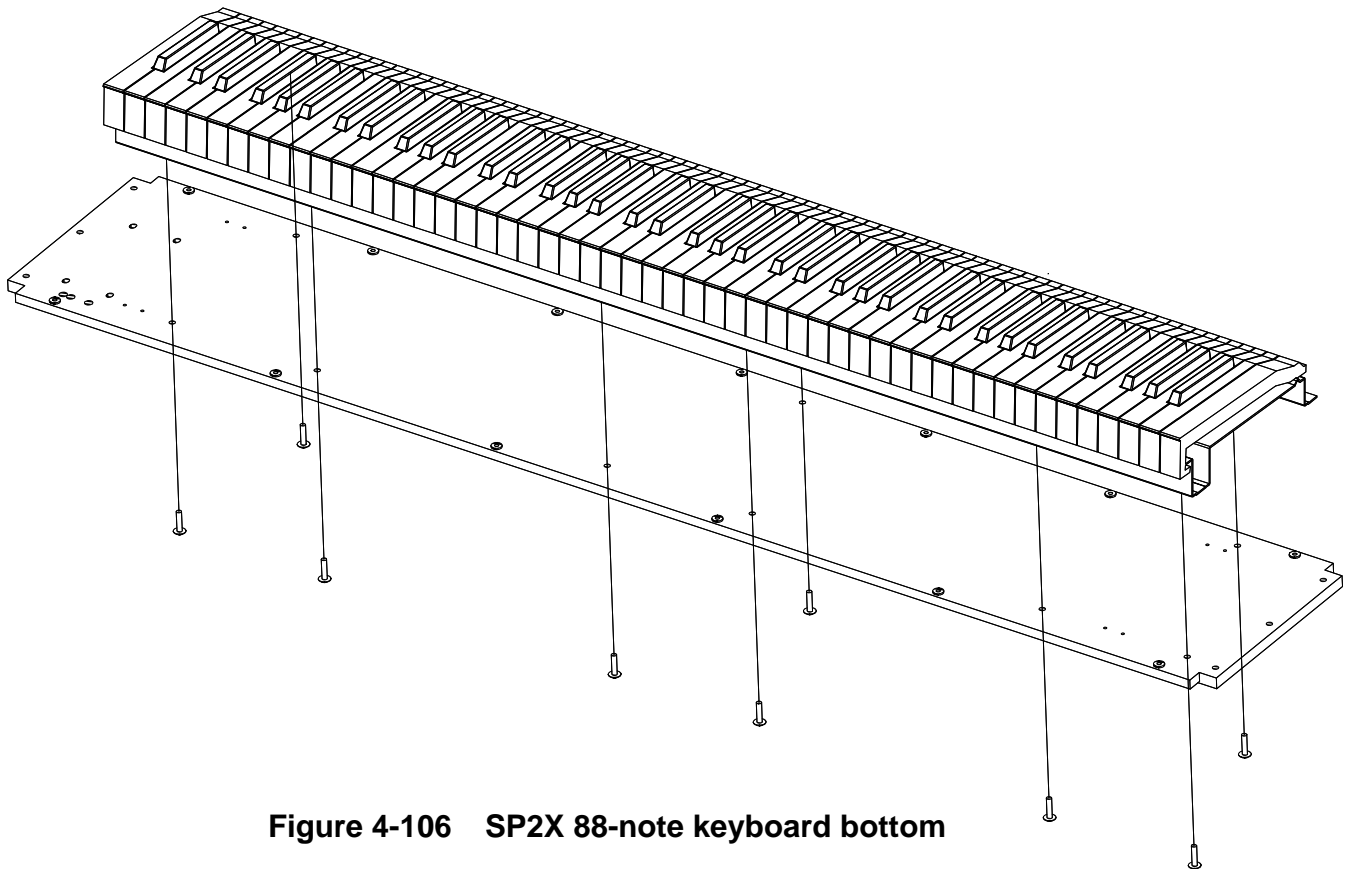

**Figure 4-106** SP2X 88-note keyboard bottom

5. Slide the SP2X back onto your work surface.
6. Place the Mod Wheel Assembly in its position on the bottom enclosure.
7. Remove the cable locking clips and disconnect the flat ribbon cables from locations J2 and J3 on the Connector Board.

8. Remove the Keyboard Assembly.

## Replacing the SP2X Keyboard Assembly

1. Place the keyboard on the bottom enclosure. Be sure that the flat ribbon cables from the keyboard are correctly positioned to connect them to the Connector Board.



**Note:** If you have disconnected the Bass and Treble ends of the flat ribbon cables from the keyboard contact boards during service, be sure that you have reconnected them and secured them with tape. Be sure that the small ribbon cable connecting the Bass and Treble Contact Boards is connected.

2. Connect the flat ribbon cables to J2 and J3 on the Connector Board and reapply the cable locking clips.
3. Secure the flat ribbon cables to the bottom enclosure. Be sure to reapply the nylon reinforced tape that secures the cables to the bottom enclosure.
4. Slide the SP2X forward so that you can install the five keyboard front screws.
5. Install the four Mod Wheel Assembly screws and washers.
6. Slide the SP2X back on to your work surface.
7. Tilt the SP2X up and install the five keyboard rear screws.

# Chapter 5

## Troubleshooting

### Introduction

#### Cables, Connectors

##### Cable Routing

In some cases, tape secures cable connections or fastens cables to the bottom enclosure. Always peel back the tape from one side when disconnecting cables so that the tape remains properly positioned.

### Surface-Mount Devices

The removal and replacement of surface-mount devices requires training and the proper equipment. If you do not have the training or equipment to remove or replace surface-mount devices, contact the service department to order a board replacement. International service technicians should contact their appropriate Young Chang Distributor.

### Saving User Data

1. Set up a MIDI recording device.
2. Connect the a MIDI cable to the MIDI Out port of the SP2X to the MIDI In port on the external device.
3. Press the **Global** button on the SP2X. Press the +/- cursor button until the segment

displays 

4. Begin recording on the MIDI recording device.

5. Press Rythm on the SP2X. The segment shows . When all objects

are saved, will  appear in the display.

6. To reload the saved objects, connect a MIDI cable from the MIDI Out port of the recording device to the SP2X's MIDI In port.

7. From the external device, begin the playback of the file.

## Boot Block

Use the SP2X's Boot Loader to enter Diagnostics or perform a Hard Reset to the unit. You can also install operating system updates and ROM objects into Flash ROM.

### Entering the Boot Block



Apply power to the unit. When the  message appears in the display, quickly press and release the **Transpose** button. The segment displays the main menu of the Boot Loader and the first available option. Use the + or - button to advance to the next option. The menu options are as follows:



— Installs new operating system software upgrades.

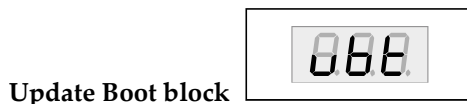

— Installs boot block updates.



— Enters the diagnostic test menu. For a complete list of tests and the procedure to execute the diagnostic tests, refer to Chapter 2, *Diagnostics*.



— Exits the boot block and returns the unit to normal operation.



— Clears the memory to factory default settings.

## Resets

### Hard Reset

There are two ways to perform a Hard Reset to the SP2X.

1. Press the Global button and press the Reset button segment displays following screen

and press + button

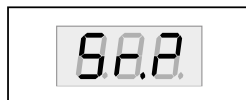

segment displays

an message. Press the + button again segment finally displays



to

continue or the **Yes** or **No** button.

## Software Updates

A computer with a MIDI interface and sequencer is necessary to transfer software to your SP2X units MIDI Sysex.

### File Formats

Software upgrades are stored as standard MIDI files. Filenames are in the format SP2XVV.MID, where X is the software block and VVV is the version number (V.VV). The following lists the possible values for X. Never install files with names that don't conform to this format; it won't work.

- bk**—boot block for keyboard models
- k**—operating system software for keyboard models.

### Installing the Operating System or Setups



**Warning:** This procedure requires performing a hard reset. All user programs and setups will be erased. Before continuing, be sure to save all user programs and setups.

1. Connect a MIDI cable from the MIDI Out port of the computer interface or sequencer to the MIDI In port on the PC2.
2. Open the first .MID file using the sequencer program.
3. Turn on the SP2X and follow the procedure to enter the Boot Block.
4. Press the **Enter** button to select "**uOS**"
5. The segment shows "**uOS**". Start playing the MIDI file from the sequencer. While a file is loading, the bottom line of the display shows the progress. If the display continues to show after starting the sequencer, stop and restart the sequence.
6. After the file is loaded, the display will show "**oK**".
7. If you have additional files to load, open the file from the sequencer and begin playing it.
8. Press the **Cancel** button twice to return to the main menu. Scroll to Hard Reset and select.



## Installing a New Boot Block



**Warning:** This procedure performs a hard reset. All user programs and setups will be erased. Before continuing, be sure to save all user programs and setups.

1. Connect a MIDI cable from the MIDI Out port of the computer interface or sequencer to the MIDI In port on the SP2X.
2. Using the sequencer program, open the first **.MID** file.
3. Turn on the SP2X and follow the [procedure to enter the Boot Block](#).

4. Press the Enter button to select .



6. The segment shows the MIDI file from the sequencer.

While a file is loading, the bottom line of the display shows the progress. If the display

continues to show

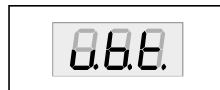

after starting the sequencer, stop and restart the sequence.

7. After the file is loaded, the unit will reset.

## Replacing the Battery

The SP2X uses a flat three volt Lithium coin cell battery. When the battery voltage runs low, the unit boots up with a low battery message.



**Note:** The battery voltage can be checked at anytime using the Scanner Diagnostics. See page 30 for more information.

### Accessing the Battery

1. Place the SP2X upside down on a flat protected surface.
2. Remove top assembly and set it safely aside.

### Removing the Battery

The battery (CR2032) in the SP2X is mounted into a holder on the Engine Board and is accessible when the access panel is removed.

1. Insert a flat plastic tool (plastic knife, pen cap, etc.) into one of the openings between the battery and the holder to lift the battery.

## Trouble Shooting

### Installing the Battery

---

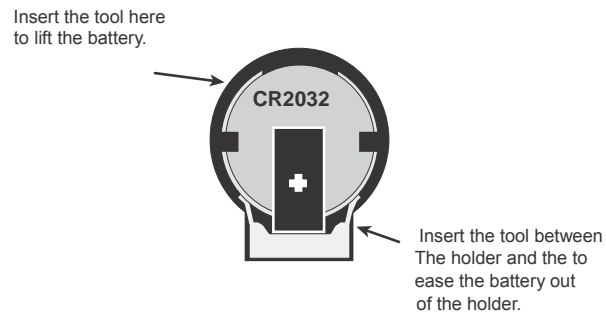

**Figure 5-1 Battery and holder**

2. Ease the battery out of the holder. If necessary, insert the plastic tool at the bottom of the holder (closest to the Engine Board) to remove the battery.

### Installing the Battery

1. Position the battery over the holder so that the positive terminal is pointing to the Engine Board.
2. Slide the battery into the holder and apply slight pressure until it snaps into place.
4. Install the seven screws to secure the top assembly

## SP2X Scanner Test

The Scanner Tests for the SP2X include separate tests for the front panel buttons and LEDs, front panel knobs including the Master Volume slider, the Mod and Pitch wheels, the keyboard, and the pedals.

To enter the Scanner Tests, first turn on the SP2X. Once the SP2X is on and ready to play, simultaneously hold down the **Main**, **Layer** and **Split** buttons. All front panel LEDs will flash and the segment will display the following:



**Figure 5-3 Segment example, SP2X scanner tests**

“SP2”, “SCn”, then “vX.Y” are displayed briefly in sequence vX.Y means version of the scanner installed the unit.

“bAt” means “Battery” and the voltage is X.Y volts. Normal battery voltage is around 3.0 volts where 3.2v is typical for a new battery and less than 2.8 means the battery is nearing the end of its life and has only a few months left. At 2.2 volts, warning will begin. A completely dead or missing battery may not read exactly 0.0v but will certainly read less than 1.0v.

Next “PCH” then “XXX” is displayed in sequence. “PCH” means the Pitch(left) Wheel and XXX is its center reading at power-on. Ideally this is 128 but anything between 120 and 136 is acceptable. New units should be adjusted to be between 126 and 130 to allow for drift over the life of the unit.

Last is a display of which option diodes have been installed. First “jPr” is displayed briefly then 4 vertical lines will show briefly. Each line represents an option diode from Opt1(leftmost) to Opt4(rightmost) A long line(2 segments long) means the corresponding diode is installed while a short line(1 segment) is not installed. Option settings normally tell the scanner software the keyboard length and weight and should match the actual unit.

### Front Panel Buttons

When a button is pressed, its LED(if any) turns on and its matrix address is shown in the display. Each press of Knob Mode will right the next Knob Mode LED in a top down sequences. Rhythm and Program button has two color led, each button press, RED and GREEN LEDs turns on alternatively.

### Front Panel Knobs

When a knob or the volume slider is moved, its name is shown briefly then its changing value is displayed. The names are

“vol” – volume slider,  
“KnA” – Knob A,  
“KnB” – Knob B,  
“KnC” – Knob C,  
“KnD” – Knob D.

The name should be correct and the value numbers should run smoothly from 0(or 1) up to 255(254) as slider moved upward or the knob clockwise. When turned very slowly, the number display will typically change in steps of two(1,3,5,,or 2,4,6,,,,) and may even switch from even to

## Trouble Shooting

### Keyboard Problems

---

odd and back which is normal. Big jumps of more than 3 counts which turning slowly may indicate a problem

however, When the control is released, its last reading should remain without changing by more than 2 counts.

### Keyboard

When a keyboard key is pressed, the key's musical pitch should be shown in the display. The first character should be the note name. The second character should be blank for white keys or a "high o (sharp sign) for black keys. The third character should be the octave number from 0 to 8. Thus Middle C will be shown as "C 4"

Besides the key name, the 3 decimal points in the display reveal important information about the rubber switches under the key being pressed. When the key is pressed partially, the left decimal point will indicate that the first rubber switch and made contact. When the key is pressed further, the middle decimal point indicates that the key is pressed further, the middle decimal points indicates that the second rubber switch has also made contact. Thus when a key is pressed slowly, the following sequence should be observed exactly 0.

Blank Display -> Correct Key name and left decimal point -> Correctly Key name and left and center decimal points

If the correct key name and only the center decimal point lights, then there is a defect associated with the first switch. If all 3 decimal points light, then either more than one key is processing at once or there is a short circuit in the connecting or on the connector.

### Switch Pedals

If a single switch pedal is plugged into the SW jack, operating it should cause a response in the display. For Kurzweil pedals, pressing the pedal should cause "S1C" to be displayed while releasing it should cause "S1o" to be displayed. Other vender's pedals may cause the opposite response. If a dual pedal is plugged in, then the Sustain (right) pedal should display as described above. The Soft pedal(left) should cause "S2C" and "S2o" to display. As with the buttons, the display should respond immediately and without flickering if pedal working properly.

### Continuous Pedals

If control pedal is plugged into the CC jack, operating it should cause the display to show "CP1" briefly then its changing values. As with the volume slide r and knobs, the value display should smoothly increase from 0 to 1 up to 254 or 255 as the pedal is pressed. This is the ideal range of a perfectly calibrated Kurzweil pedal. Many pedals may only reach 248-250 which acceptable. All should go down to 0 or 1 however

## **Power Problems**

### **Dead**

1. Before opening the unit, verify the following:
  - The AC outlet is supplying power.
  - The AC adapter is properly connected to the unit.
2. Check the power switch, power jack and AC adapter.
3. Refer to the Interconnect Diagram. See page 5-XX. Check all related connections.
4. Refer to the Connector Board schematics and check all supply voltages.

## **Audio Problems**

### **No Audio**



1. Run the Scanner Diagnostics to check the volume slider operation.
2. Refer to the Interconnect Diagram. See 5-XX .
3. Check the standard wire from J9 on the Engine Board to J15 on the Connector Board.
4. Check the solder connections at the connectors.
5. Refer to the Engine Board schematics and check the signal activity on the DAC, U28.
6. Trace the signal path.

## **Front Panel Problems**

### **Buttons, Knobs or Controllers not working**

1. Run the Scanner Tests.
2. Refer to the Interconnect Diagram. See page 5-XX.
3. Check all related cables.
4. Disconnect and reseal the cables.
5. Check the solder connections at the connectors.
6. Check front panel ribbon cable(s).
7. Refer to the Connector Board schematics and check U12, IC Scanner 38869, for signal activity.

## **Keyboard Problems**

### **Dead Keyboard**

1. Check the flat ribbon cables connecting the keyboard Bass and Treble Contact Boards to the Connector Board, locations J2 and J3. Be certain that the cables are not loose or damaged.
2. Disconnect and reseal the cables.

## **Trouble Shooting**

---

### **Keyboard Problems**

3. Refer to the Connector Board schematics.
4. Check U12, IC Scanner 38869 on the Connector Board for keyboard signals.
5. Trace signal path.
- . Find and replace bad component(s) or order a board replacement. Dead Note(s)

#### **One or More in a Section**

1. Remove related contact board.
2. Check contact strip for dirt, damage or wearing. Clean dirty contacts with denatured alcohol. Replace damaged or worn contact strip.
3. Install contact strip.
4. If section is still dead, remove strip and check contact board for shorts, cold solder joints, etc.
5. Find and replace bad component(s) or order replacement board.

#### **Mechanical Noise**

1. Check keyboard for broken key weights, support brackets, or ripped contacts.

# SP2X Interconnect Diagram

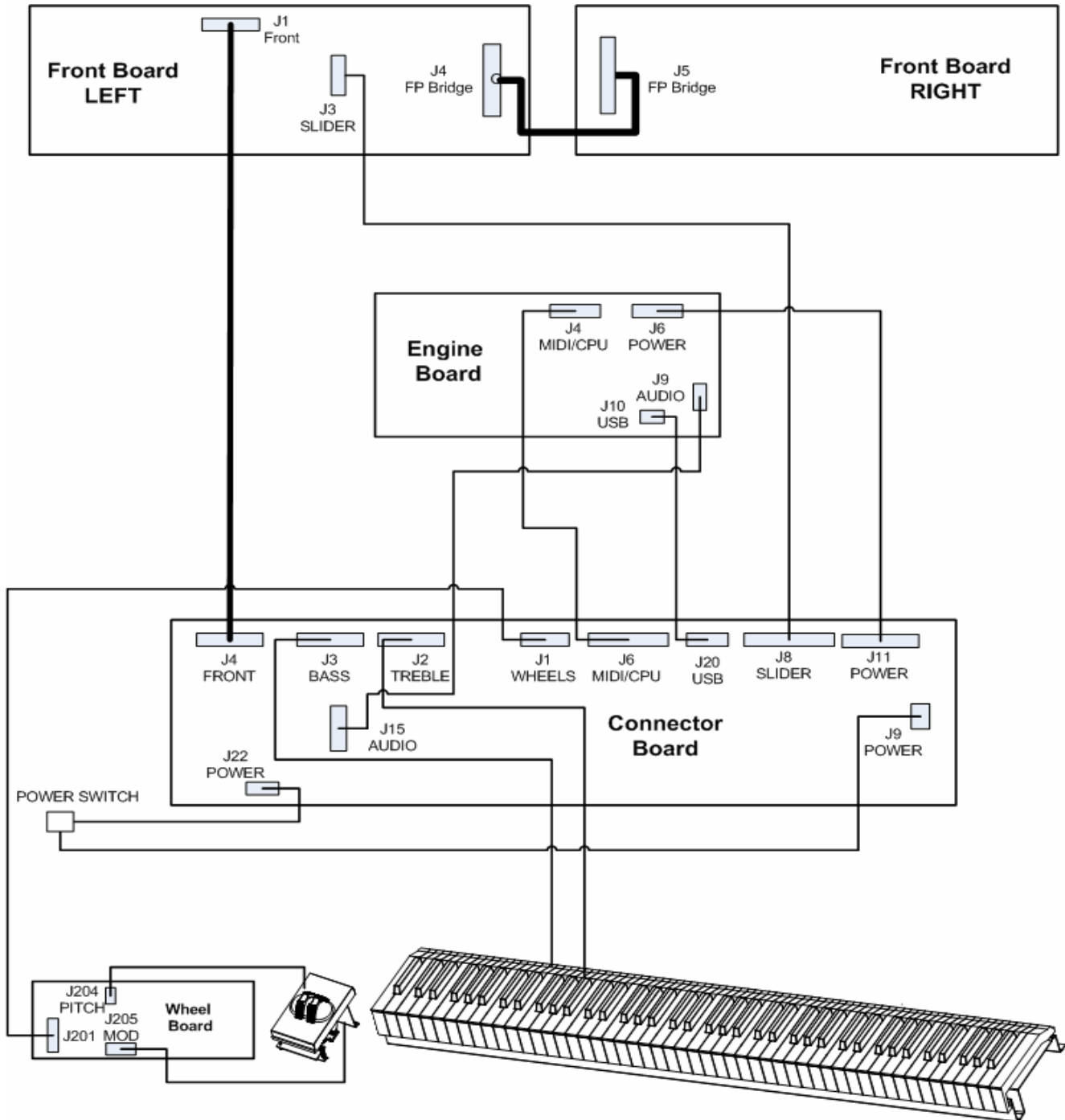

# Chapter 6

## Parts Lists

### Introduction

The parts lists included in this chapter cover all models of the SP2X. Some printed circuit boards and assemblies are used in more than one model. Therefore, the parts lists on the following pages are listed under these headings:

The following two tables list the printed circuit boards and assemblies by model.

### SP2X Printed Circuit Boards and Assemblies

Part No.	Description	Page
Nxxxxxx	Final Assembly, SP2X	page 36
N012131702	Engine Board	page 37
N012300063	Pitch & Mod Wheel Assembly	page 40
N012131802	Connector Board	page 41
N012131901	Front Panel Board	page 44



**Part List**

**Final Assembly**

**Final Assembly**

Part No	Item	Description	Unit	Q'ty	Location
N013030951	bending strip(Iron)		EA	10	
N015048226	FELT 1TX16X1350 BLK KEYBOARD	PC88/MX/PC1/2X	EA	1	
N022003720	CABLE CLAMP	20PIN	EA	4	
N022003726	CABLE CLAMP	26PIN	EA	2	
N025224508	TAPPING SCREW-2	BH 3.5X8 WHITE With washer	EA	32	
N025223307	TAPPING SCREW-2	BH 3.5X6 BLK	EA	2	
N025223410	TAPPING SCREW-2	BH 3X10 BLK	EA	2	
N025323408	MACHINE SCREW	BH M4X8 BLK	EA	13	
N025323414	MACHINE SCREW	BH M4X14 BLK	EA	13	
N025323422	MACHINE SCREW	BH M4X25 BLK	EA	6	
N025328822	MACHINE SCREW	BH 5X22 BLK With washer	EA	9	
N039000701	SLIDE VOLUME FELT 0.3TX12X70	EP/YDP2000N/PC1SE	EA	1	
N035027211	POWER CORD STRAIN RELIEF	PC-88	EA	1	
N039004322	Cable Mount Base	DAMD-10/PC161	EA	2	
N092100205	Magic Tape(65M)	25X25	ROL	0.0009	
N091020617	Production History Card	SP76/88/88X	EA	1	
N013042304	CABLE KEYBOARD TREBLE 20P 500mm	PC1/SP2	EA	1	Refere to Dwg. C3-0285
N013042305	CABLE KEYBOARD BASS 20P 600mm	SP2	EA	1	Refere to Dwg. C3-0285
N013042902	CABLE FRONT PANEL LINK 26PIN 50mm	SP2	EA	1	Refere to Dwg. C3-0303
N013048403	CABLE FRONT TO CONNECTOR B/D 20P 600mm	SP2	EA	1	Refere to Dwg. C3-0354
N013025065	CABLE FRONT TO CONNECTOR B/D 7P 520mm(SLIDER)	SP2	EA	1	Refere to Dwg. C3-0322
N013048005	CABLE ENGINE TO CONNECTOR B/D 8P 1100mm(POWER)	SP2	EA	1	Refere to Dwg. C3-0350
N013048006	CABLE ENGINE TO CONNECTOR B/D 10P 1200mm(DATA)	SP2	EA	1	Refere to Dwg. C3-0353
N013001524	CABLE ENGINE TO CONNECTOR B/D 5P 1250mm(AUDIO)	SP2	EA	1	Refere to Dwg. C3-0207
N013048207	CABLE WHEEL TO CONNECTOR B/D 550mm	SP2	EA	1	Refere to Dwg. C3-0352
N013037701	CABLE ENGINE TO CONNECTOR B/D 4P 1100mm(USB)	SP2	EA	1	
N035026330	SLIDER KNOB (RED)	PC3/SP2	EA	1	
N035026331	VOLUME KNOB(YELLOW)	SP2	EA	4	
N035020640	LED WINDOWS	SP2	EA	1	
N032036570	ENCLOSURE BOTTOM REAR	SP2	EA	1	
N032036571	KEYSLIP	SP2	EA	1	

**Part List**  
**Engine Board**

**Engine Board, N012131702**

Part No	Item	Description	Unit	Q'ty	Location
N034010184	LABEL SERIAL NUMBER SOUND	SP2	EA	1	
N035040105	BATTERY COINCELL 3V, 195mah	CR2032 TOSHIBA	EA	1	
N012131701	ASSY PCB ENGINE(DIP)	SP2	EA	1	
N035040201	BATTERY HOLLDER TOSHIBA	(BV-32) PC-88	EA	1	J13
N041010302	JUMPER 0.1"SP 2POS	JUMPER CAP	EA	2	@J2,J16
N041030002	HEADER .1"SP SGL ROW 2P	(22-03-2021)	EA	1	J16
N041030003	CON HDR SIP 0.1" SQR PIN JMPR .23HD .12"TL	3 Pos	EA	2	J2,14
N041030150	HEADER DUAL 0.1"SQR 50POS	DIGIKEY S2012-50-ND	EA	1	J1
N041034004	HEADER 0.098"SP 4P	(22-03-5045)	EA	1	J10
N041034005	HEADER .098"SP 5P	(22-03-5055)	EA	1	J9
N041034008	HEADER .098"SP 8P	(22-03-5085)	EA	1	J6
N041034010	HEADER .098"SP 10P	(22-03-5105)	EA	1	J4
N055004301	EMI FILTER,DUAL	EXC-EMT470BT	EA	1	T2
N051102103	RELAY, 5V DPDT	(G6H-2-DC5)	EA	2	RY1,RY2
N064003502	IC LINEAR +5V	LM78M05 500mA TO-220	EA	1	U29
N012131700	ASSY PCB ENGINE(SMD)	SP2	EA	1	
N033131700	FAB PCB ENGINE, 4LAYER, 190mm x 90mm	SP2	EA	1	
N051064004	RES TF	47Ω 5% 1/16W 0603	EA	1	R68
N052064010	RES TF	100Ω 5% 1/16W 0603	EA	2	R19,R32
N051064012	RES TF	121Ω 1% 1/16W 0603	EA	2	R111,R112
N051064022	RES CF	220Ω 5% 1/16W 0603	EA	1	R22
N051064025	RES TF	330Ω 5% 1/16W 0603	EA	2	R24,R91
N051066620	RES TF	620Ω 5% 1/16W 0603	EA	1	R110
N051064820	RES TF	820Ω 5% 1/16W 0603	EA	1	R29
N051064100	RES CF	1KΩ 5% 1/16W 0603	EA	3	R3,R30,R54
N051064130	RES CF	1.3KΩ 5% 1/16W 0603	EA	1	R1
N052064015	RES TF	1.5KΩ 5% 1/16W 0603	EA	1	R4
N051064220	RES TF	2.2KΩ 5% 1/16W 0603	EA	2	R2,R7
N051064470	RES TF	4.7KΩ 5% 1/16W 0603	EA	3	R5,R80,R85
N051064110	RES CF	10KΩ 5% 1/16W 0603	EA	19	R9,R12,R13,R14,R18,R55,R69,R70,R72,R73,R74,R75,R78,R104, R105,R106,R107,R108,R109

**Part List**  
**Engine Board**

N051064109	RES TF	1M $\Omega$ 5% 1/16W 0603	EA	4	R27,R83,R84,R86
N051066018	RES TF	18 $\Omega$ 1% 1/16W 0603	EA	2	R81,R82
N051066052	RES TF	60.4 $\Omega$ 1% 1/16W 0603	EA	1	R114
N051066196	RES TF	196 $\Omega$ 1% 1/16w 0603	EA	1	R113
N051064469	RES TF	4.75K $\Omega$ 1% 1/16W 0603	EA	17	R36,R37,R38,R39,R42,R43,R44,R45,R48,R49,R50,R51,R52,R57,R58,R59,R60
N051066107	RES TF	10.7K $\Omega$ 1% 1/16W 0603	EA	8	R35,R40,R41,R46,R47,R53,R56,R61
N051100010	RES NET QUAD ISO	10K $\Omega$ 5% 1/16W 3.2mmX1.6mm	EA	4	RN1,RN2,RN3,RN4
N052007814	CAP CER NPO	15pF 50V 5% NPO 0603	EA	1	C32
N052007022	CAP CER NPO	22pF 100V 5% 0603	EA	2	C169,C171
N052007833	CAP CER NPO	33pF 50V 5% NPO 0603	EA	2	C33,C34
N052007809	CAP CER NPO	100pF 50V 5% NPO 0603	EA	1	C6
N052007827	CAP CER NPO	270PF 50V 5% NPO 0603	EA	8	C58,C61,C63,C66,C69,C72,C74,C76
N051007810	CAP CER	1000PF 50V 10% X7R 0603	EA	5	C59,C64,C70,C75,C128
N052007801	CAP CER X7R	0.01UF 50V 10% 0603	EA	1	C207
N052007825	CAP CER X7R	0.1UF 50V 10% X7R 0603	EA	105	C2~ C4,C8~C14,C19~C21,C51,C54,C56,C60,C62,C65,C67,C68,C71,C73,C129~C164,C165~C168,C170,C172~C186,C188~C199,C206,C210~C212,C215~C225
NEW	CAP CER X5R	10UF 10V 10% X5R 0805	EA	6	C213,C214,C226,C227,C228,C229
N052901610	CAP ELECT GP	10uF 16V 20% SZB SMT	EA	4	C1,C200,C202,C208
N052901011	CAP ELECT GP	22uF 10V 20% SZC SMT	EA	1	C164
N052901601	CAP ELECT GP	100uF 16V 20% SZC ZMT	EA	2	C201,C204
N052901622	CAP ELECT GP	220UF 10V 20% SZE SMT	EA	2	C17,C209
N053000703	DIODE RECT GP SMT 1A S1A S	1N4001 1206	EA	1	D7
N053000802	DIODE SWITCH	1N4148 SMT DL-35	EA	2	D6,D8
N054000102	TRANSISTOR	MMBT3904 SOT-23	EA	1	Q1
N054000802	TRANSISTOR	MMBT2222L SOT-23	EA	1	Q3
N054010101	TRANSISTOR	MMBT2907 SOT-23	EA	1	Q2
N055001505	IND FE BD 2.5-TURN SMT		EA	1	L3
N055001509	IND FE BD	500mA 600 OHM @ 100MHz 0805	EA	4	L14,L16,L17,L18
N059010062	XTL 24.576MHZ +/-50PPM FND	18PF SMT 아부라콘(A245K9Y)	EA	1	X2
N059010081	XTAL 6.0MHz FND PAR	50ppm SMT HC49	EA	1	X4
N061000910	IC LOGIC	NC7SU04 UNBUF INV SoP23-5	EA	2	U22,U24
N061007139	IC LOGIC	74LCX139 TSSOP16	EA	1	U9
N061007142	IC LOGIC	IC DIG 74LCX2245 8-Bit BUS XCEIVER w/ OUTPUT RES SOIC20-300	EA	1	U15

**Part List**  
**Engine Board**

N061007143	IC LOGIC	IC DIG 74LCX162245 16-Bit BUS XCEIVER w/ OUT RES SSOP48-300	EA	2	U12,U13
N061007144	IC LOGIC	74VHC14 SOP14-150	EA	1	U38
N061011008	IC LOGIC	74AC08 SOP14-150	EA	1	U39
N062004905	IC IF UART ST16C550 W/FIFO	PLCC44P	EA	1	U23
N062004923	IC DAC	IC IF DAC AK4382VF DL 24B DS +5VS VSOP16	EA	1	U28
N062005704	IC GAL 16V8A-15QJ	SMT,PLCC20	EA	1	U26
N062100410	IC MEM SRAM 256kX16 55nS	TSOP44-400 LOW PWR	EA	1	U3
N062100419	IC MEM DDR SDRAM 2Mx16x4	MT46V8M16TG(MICRON)	EA	1	U11
N064003403	IC REG ADJ	LM1117SX-ADJ TO-263	EA	2	U55,U56
N061008025	IC REG 2.5V FIXED	LP2992IM5-2.5	EA	1	U57
N064003511	IC ANA OPAMP	IC ANA OPAMP NJM4580 DL BIP LO-NOIS SOP8-160	EA	2	U27,U30
	IC ANA OPAMP	IC ANA OPAMP NJM4580M	EA	2	U27,U30
N083017801	IC MASKROM OKI MR27V128000J	SP2, 830178-001	EA	1	U47
N053000712	DIODE SHTKY SIG 5NS LO-C S	BAS40 SOT-23	EA	2	D2,D11
N062001301	IC MCU 68331CPV25	MOTOROLA	EA	1	U1
N062005532	IC FLASH MEMORY	AM29F160D(AMD)	EA	1	U4
N266000420	IC ASIC VLSI MARA	PBGA388L - 35x35mm, 1.27mm pitch	EA	1	U46
N062001400	IC USB FUNCTION GENERAL PURPOSE	PHIUSB12 TSSOP28	EA	1	U48

**Part List**  
**Connector Board**

**Pitch and Mod Assembly, N012300063**

Part No	Item	Description	Unit	Q'ty	Location
N012300063	ASSY PCB PITCH&MOD WHEEL	SP2	EA	1	
N013040122	CABLE POT TO WHEEL BD,3PIN #26 AWG 4"	SP2	EA	2	
N033123001	FAB PCB PITCH&MOD WHEEL	PC2/PC1SE	EA	1	
N041030004	Header .1"SP 4PIN,22-27-2041	PC1SE	EA	1	
N041034005	HEADER .098"SP 5P (22-03-5055)	YDP/RE110/PC1SE	EA	1	
N051100118	RES CF EP/EG20/YDP2000N/PC1SE	220Ω 5% 1/8W	EA	2	
N051100132	RES CF YDP/EP/EG20/YDP2000N/PC1SE	1KΩ 5% 1/8W	EA	1	
N051100310	RES MF YDP2000N	1.0 kΩ 1% 1/8W	EA	1	
N051100316	RES MF	1.5 kΩ 1% 1/8W	EA	1	
N051100336	RES MF	4.99 kΩ 1% 1/8W	EA	2	
N051100354	RES MF EP/EG20	10.0 kΩ 1% 1/8W	EA	2	
N051100379	RES MF EG20	110K 1% 1/8W	EA	2	
N051100439	RES MF	30.1 kΩ 1% 1/8W	EA	3	
N051100850	RES MF	2.49KΩ 1% 1/8W	EA	1	
N051101401	RES POT 100K 3/4 TURN	EP/PC1SE	EA	2	
N051101410	RES TRIMPOT ,50K 3/4 TURM	PC1SE	EA	1	
N051102301	POT ROTARY	10K(K2600/X)	EA	2	
N052001204	CAP CERMONO Z5U EP/EG20/YDP2000N	.1UF 50V 20% .3AX	EA		
N064001903	IC LINER OPAMP DIP8	TLC2272CP	EA	3	
N092100402	Heat shrink 3Φ		ROL	0.002	

**Part List**  
**Connector Board**

**Connector Board, N012131802**

N012131802	ASSY CONNECTOR B/D (inspection)	SP2	EA	1	
N012131801	ASSY PCB CONNECTOR(DIP)	SP2	EA	1	
N025224506	TAPPING SCREW-2	BH 3.5X6 WHITE	EA	4	
N032064803	Heat Sink EXTRUSION HEAT TRANSFER	SP2	EA	1	
N041021902	DC JACK	ID:2.1mm OD:5.5mm	EA	1	J12
N041030310	CONN MIDI JACK,3-GANG	YKF 51-5041(JALCO)	EA	1	J5
N041033310	CONN USB FEMALE	TYPE-B RECEPTICLE	EA	1	J19
N041031110	JACK 1/4" STEREO	BELTION(BPJ-BBB-P8)	EA	5	J7,J10,J14,J16,J17
N041034002	HEADER 0.098" SP 2P	(22-03-5025)	EA	2	J9,J22
N041034004	HEADER 0.098"SP 4P	4P(22-03-5045)	EA	1	J20
N041034005	HEADER .098"SP 5P	(22-03-5055)	EA	1	J15
N041034006	HEADER .098"SP 6P	(22-03-5065)	EA	1	J1
N041030511	HEADER .098"SP 7P		EA	1	J8
N041034008	HEADER .098"SP 8P	(22-03-5085)	EA	1	J11
N041034010	HEADER .098"SP 10P	(22-03-5105)	EA	1	J6
N041031220	HEADER .1"SP DUAL ROW 20P	(057-020-153)	EA	3	J2,J3,J4
N052004309	CAP ELECT	1uF 16V 20%	EA	1	C44
N052002401	CAP ELECT	100UF 16V 20% 0.1" DIP	EA	1	C37
N052901602	CAP ELC GP 0.197"SP RAD	1000UF 16V 20% ECE-A1CU102	EA	1	C42
N052001712	CAP ELECT	1000uF 25V	EA	5	C27,C28,C31,C34,C47
N052001722	CAP ELECT	2200uF 25V	EA	1	C48
N052004410	CAP ELECT	10000uF 16V	EA	1	C35
N053020101	DIODE	1N4002(1A)	EA	5	D11,D12,D14,D15,D19
N053020111	DIODE BRIDGE RECT(4amp)	KBU04	EA	1	D13
N054010301	TRANSISTOR NPN	KSC2331-Y TO-92L	EA	2	Q11,Q12
N064010805	IC LINER +5V	LM78T05 TO-220	EA	1	U10
N064010806	IC LINER +12V	LM78M12 TO-220	EA	1	U8
NEW	IC OPT COUPLER	6N138	EA	1	U4
NEW	IC LINEAR -12V	LM79L12 SOP8	EA	1	U9

**Part List**

**Connector Board**

N012131800	ASSY PCB CONNECTOR(SMD)	SP2	EA	1	
N033131800	FAB PCB CONNECTOR, 2LAYER, 300mm x 80mm	SP2	EA		
N051101706	RES TF	47Ω 5% 1/8W 1206	EA	2	R65,R78
N051101708	RES CF	56Ω 5% 1/8W 1206	EA	4	R16,R17,R18,R19
N051101714	RES MF	110Ω 5% 1/8W 1206	EA	8	R14,R15,R21,R22,R24,R25,R41,R48
N051101718	RES CF	220Ω 5% 1/8W 1206	EA	4	R23,R26,R58,R59
N051101724	RES CF	470Ω 5% 1/8W 1206	EA	2	R62,R70
N051101730	RES CF	1.0KΩ 5% 1/8W 1206	EA	2	R60,R83
N051101734	RES TF	1.5KΩ 5% 1/8W 1206	EA	1	R72
N051101738	RES CF	2.2KΩ 5% 1/8W 1206	EA	1	R27
N051120030	RES CF	3KΩ 5% 1/8W 1206	EA	2	R68,R69
N051101721	RES CF	270Ω 5% 1/8W 1206	EA	1	R20
N051120056	RES CF	5.6KΩ 5% 1/8W 1206	EA	2	R63,R67
N051101757	RES CF	10K 5% 1/8W 1206	EA	14	R2~R6,R11~R13,R28,R30,R32,R37,R46,R57
N051101780	RES CF	100KΩ 5% 1/8W 1206	EA	1	R56
N051101790	RES CF	1.0MΩ 5% 1/8W 1206	EA	5	R1,R10,R29,R73,R99
N051125201	RES CF	200Ω 1% 1/4W 1210	EA	4	R75,R76,R81,R82
N051103151	RES CF	15K 1% 1/8W 1206	EA	8	R61,R64,R66,R71,R74,R77,R79,R80
N051101747	RES TF	4.7MΩ 5% 1/8W 1206	EA	1	R36
N051101705	RES CF	4.7K OHM 5%1206	EA	1	R35
N051100010	RES NET QUAD ISO	10KΩ 5% 1/16W 3.2mmX1.6mm	EA	5	RN1,RN2,RN4,RN9,RN10
N051100011	RES NET QUAD ISO	100Ω 5% 1/16W 3.2mmX1.6mm	EA	8	RN3,RN5,RN6,RN7,RN8,RN11,RN12,RN13
N052007033	CAP CER	33pF 50V 5% NPO 1206	EA	2	C5,C6
N052007401	CAP CER NPO	100pF 50V 5%1206	EA	2	C39,C43
N052007402	CAP CER	1000PF X7R 1206	EA	19	C1~C3,C8,C12~C18,C21,C23~C25,C45~46, C49,C50
N052007503	CAP CER X7R	0.1UF 50V 10% 1206	EA	16	C4,C7,C9,C10,C11,C19,C20,C22,C29,C30,C32,C33,C36, C38,C40,C41

**Part List****Connector Board**

N053000703	DIODE RECT GP SMT 1A S1A S	1N4001 6.00x3.00mm	EA	1	D17
N053000802	DIODE SWITCH	1N4148 SMT DL-35	EA	5	D1,D2,D3,D5,D18
N053020101	DIODE	1N4002(1A)	EA	5	D11,D12,D14,D15,D19
N054000802	TRANSISTOR	MMBT2222L SOT-23	EA	2	Q5,Q10
N054002906	TRANSISTOR	MMBT2907L SOT-23	EA	5	Q1,Q6,Q7,Q8,Q9
N055001505	IND FE BD 2.5-TURN SMT		EA	4	L1,L2,L3,L4
N059010081	CRYSTAL 6.144Mhz	FND PAR 18pF 50ppm SMT HC49	EA	1	Y1
N061010302	IC LOGIC	74HCU04 SOP14	EA	1	U5
N061014002	IC LOGIC	74HC4051 SOP16-200	EA	1	U6
N061014003	IC LOGIC	MC74HC541DW SOP-20	EA	1	U2
N063002302	IC OPT COUPLER PC410	SOP6-170(SECOND SOURCE)	EA	1	U3
N064003508	IC ANA OPAMP DL BIP LO-NOI	NE5532A SOP8-160	EA	1	U11
N064010804	IC LINEAR -12V	LM79L12 SOP8	EA	1	U9
N262100701	IC M38869 FFLAGP	FLASH MEMORY	EA	1	U12



**Part List**

**Front Panel Board**

**Front Panel Board, N012131901**

N012131901	ASSY PCB LEFT PANEL (DIP)	SP2	EA	1	
N035026160	LARGE BUTTON NO LED	PC3	EA	3	
N035026161	LARGE BUTTON W/LED	PC3	EA	6	
N035023601	LED SPACER	LH-3-6	EA	3	@D1,D2,D3
N041030511	HEADER .098"SP 7P	(22-03-5075)	EA	1	J3
N041031220	HEADER .1"SP DUAL ROW 20P	(057-020-153)	EA	1	J1
N041030326	HEADER .1"SP DUAL ROW 26P	(057-026-153)	EA	1	J4
N051101421	RES POT 10K LIN H15xL9.8xW12.5	V09H20F	EA	4	R27,R28,R29,R30
N051101502	SLIDER VOLUME	10KB-LIN 45mm	EA	1	R31
N052002422	CAP ELECT ECE-BOJU471	470UF 6.3V 3.5mmSP 0.11mm	EA	2	C1,C2
N045010111	LED T1 RED HI.EFF.DIFFUSED	LTL-4221	EA	3	D1,D2,D3
N045001830	LED DISPLAY	3 X 7 SND630A	EA	1	DS1
N012131900	ASSY PCB LEFT PANEL (SMD)	SP2	EA	1	
N033131900	FAB PCB LEFT, 2LAYER, 360mm x 90mm	SP2	EA	1	
N043010211	TACT SWITCH(160gf, BLUE/GRAY)	SAMWON TSM155JK	EA	9	SW1~SW9
N051005011	RES CF	4.7ohm 5% 1/8W	EA	1	R16
N051064033	RES TF	33Ω 5% 1/16W 0603	EA	8	R1,R4,R8,R11,R15,R17,R18,R32
N051066010	RES TF	10K Ohm 1% 1/16W 0603	EA	18	R2,R3,R5~R7,R9,R10,R12~R14,R19~R26
N052007503	CAP CER X7R	0.1UF 50V 10% 1206	EA	3	C3,C4,C5
N054000802	TRANSISTOR	MMBT2222 SOT-23	EA	8	Q11~18
N054002906	TRANSISTOR PNP	MMBT2907L SOT23	EA	10	Q1~Q10
N061000302	IC LOGIC SOP16	74LS145	EA	1	U1
N061020502	IC LOGIC OCTAL LATCH SOIC 20	74HC373A	EA	1	U2
N061014003	IC LOGIC SOP20	MC74HC541DW	EA	1	U3
N045010902	LED SMT RED WATER CLEAR 120 degree view 1206	KINGBRIGHT AP3216SURCK	EA	6	D4~D9
N012132001	ASSY PCB RIGHT PANEL(DIP)	SP2	EA	1	
N035026161	LARGE BUTTON W/LED	PC3	EA	8	
N035026162	LARGE BUTTON W/LED 4-Gang	<1,2,3,4> SP2	SET	1	
N035026163	LARGE BUTTON W/LED 4-Gang	<6,7,8,9>SP2	SET	1	
N035026164	LARGE BUTTON W/LED 4-Gang	<5>,	SET	1	
N035026165	LARGE BUTTON W/LED 4-Gang	<0,+/-,CANCEL,ENTER>	SET	1	
N041030326	HEADER .1"SP DUAL ROW 26P	(057-026-153)	EA	1	J5
N012132000	ASSY PCB RIGHT PANEL(SMD)	SP2	EA	1	

**Part List****Front Panel Board**

N033132000	FAB PCB RIGHT, 2LAYER, 265mm x 90mm	SP2	EA	1	
N043010211	TACT SWITCH(160gf, BLUE/GRAY)	SAMWON TSM155JK	EA	24	SW10~SW33
N045010902	LED SMT RED WATER CLEAR 120 degree view 1206	KINGBRIGHT AP3216SURCK	EA	22	D10~D15,D16~D32
N045010912	LED SMT RED/GREEN WATER CLEAR	KINGBRIGHT AA2734SRSGC	EA	2	D14,D33

# Chapter 7

## Schematics

Description	Page No.
Engine Board – Microprocessor Interface	page 47
Engine Board – DRAM, Level Shifter	page 48
Engine Board – MARA	page 49
Engine Board – Sound ROM, USB, Uart, Bridge	page 50
Engine Board – DAC	page 51
Engine Board – Power, Clock	page 52
Connector Board – 38869 Interface	page 53
Connector Board – MIDI, Pedal, USB	page 54
Connector Board – Power, Reset, Headphone	page 55
Front Board – Front Board Left	page 56
Front Board – Front Board Right	page 57

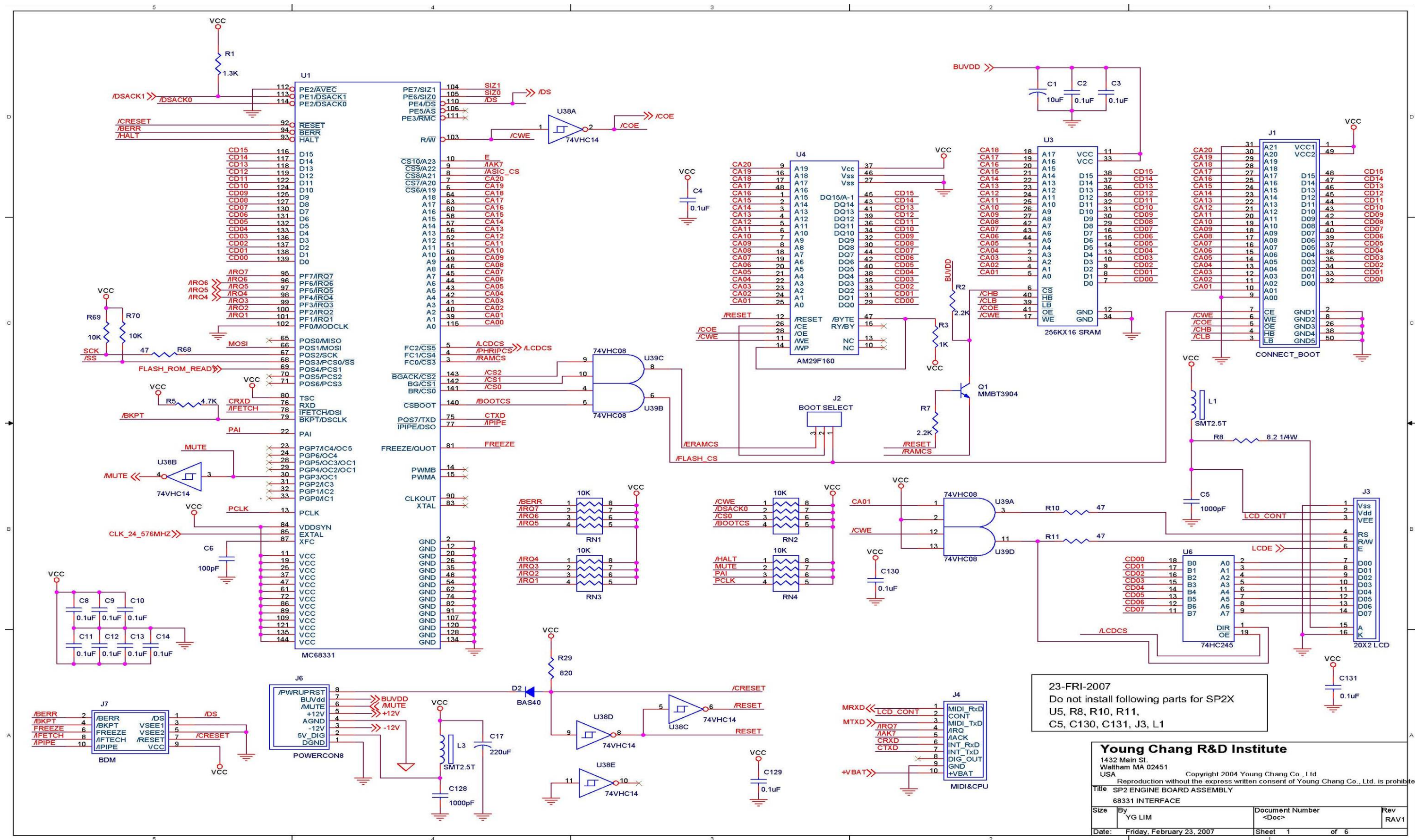

**Young Chang R&D Institute**  
1432 Main St.  
Waltham MA 02451  
USA

Copyright 2004 Young Chang Co., Ltd.  
Reproduction without the express written consent of Young Chang Co., Ltd. is prohibited.

Title: SP2 ENGINE BOARD ASSEMBLY  
68331 INTERFACE

Size	By	Document Number	Rev
	YG LIM	<Doc>	RAV1

Date: Friday, February 23, 2007  
Sheet 1 of 6



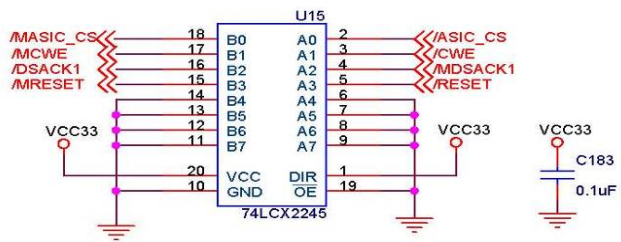
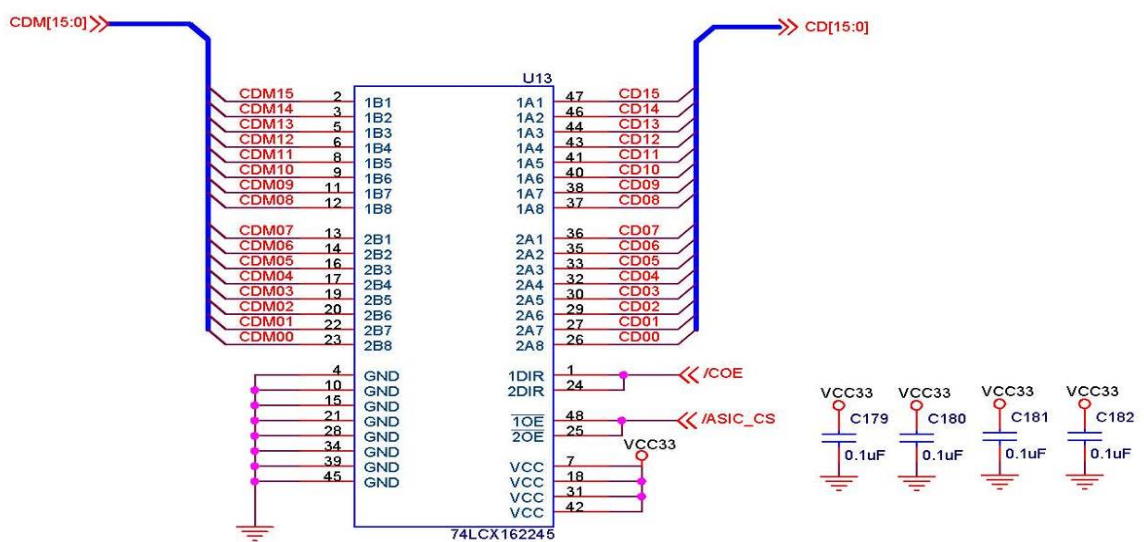
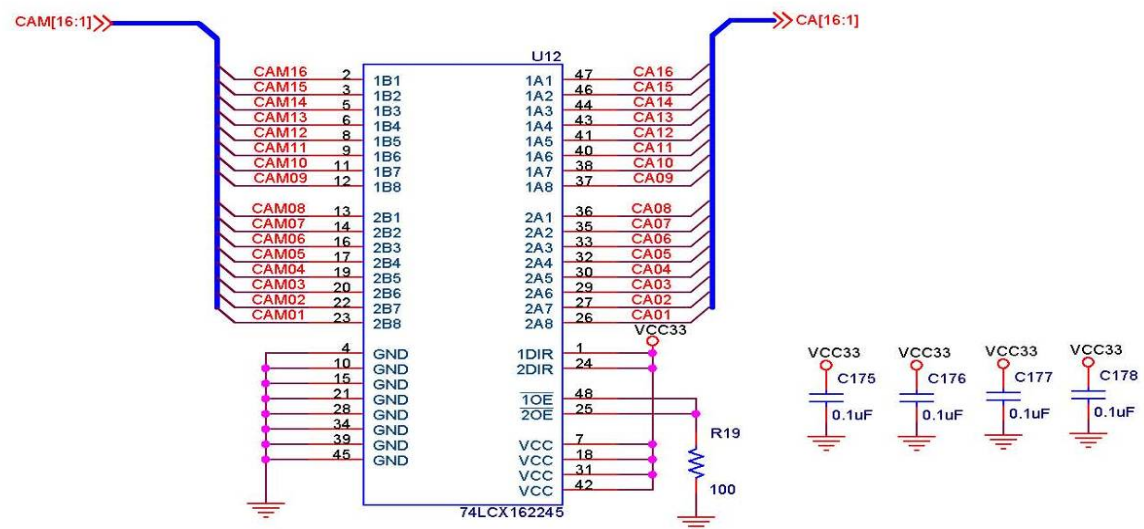

**IMPORTANT!**  
 Signals DDR\_D\_[15:8] and DDR\_DQS\_2 should all have equal length copper traces. Signals DDR\_D\_[7:0] and DDR\_DQS\_0 should all have equal length copper traces.

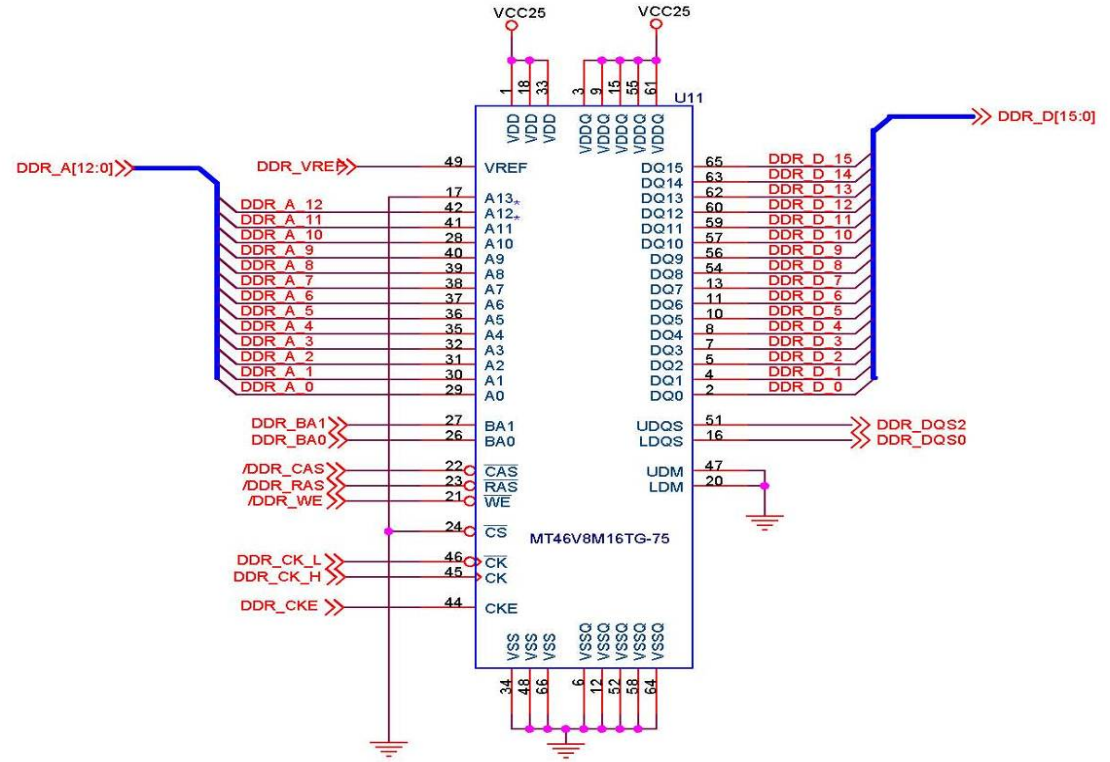
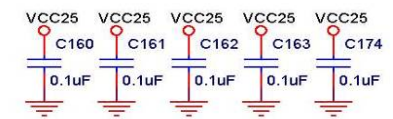

SP2.BOM.Engine.REV3.VER3

**Young Chang R&D Institute**  
 1432 Main St.  
 Waltham MA 02451  
 USA

Copyright 2004 Young Chang Co., Ltd.  
 Reproduction without the express written consent of Young Chang Co., Ltd. is prohibited.

Title: SP2 ENGINE BOARD ASSEMBLY  
 DRAM, LEVEL SHIFTER

Size	By	Document Number	Rev
	YG LIM	<Doc>	RAV1
Date:	Friday, February 23, 2007	Sheet 2	of 6

MARA  
U46

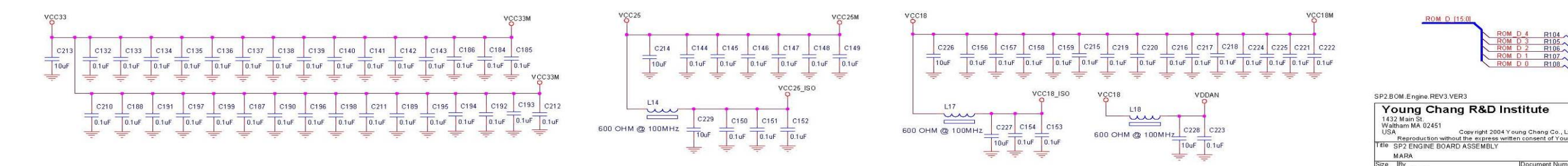
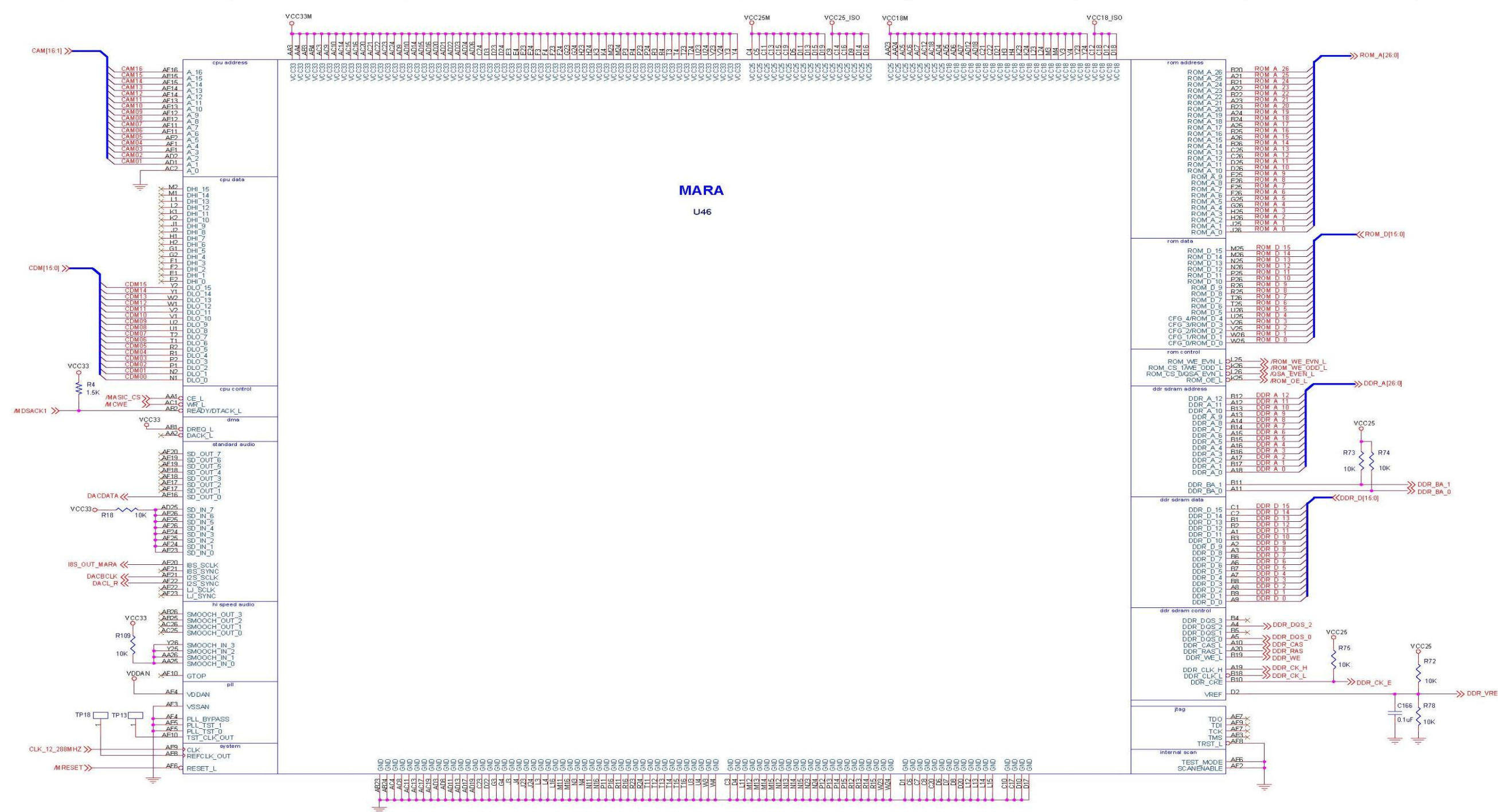

SP2.BOM.Engine.REV3.VER3  
**Young Chang R&D Institute**  
 1432 Main St  
 Waltham MA 02451  
 USA  
 Copyright 2004 Y. Chang Co., Ltd.  
 Reproduction without the express written consent of Y. Chang Co., Ltd. is prohibited.  
 Title: SP2 ENGINE BOARD ASSEMBLY  
 MARA  
 Size: YG LIM  
 Date: Friday, February 23, 2007  
 Document Number: <Doc>  
 Sheet: 3 of 6  
 Rev: RAV1



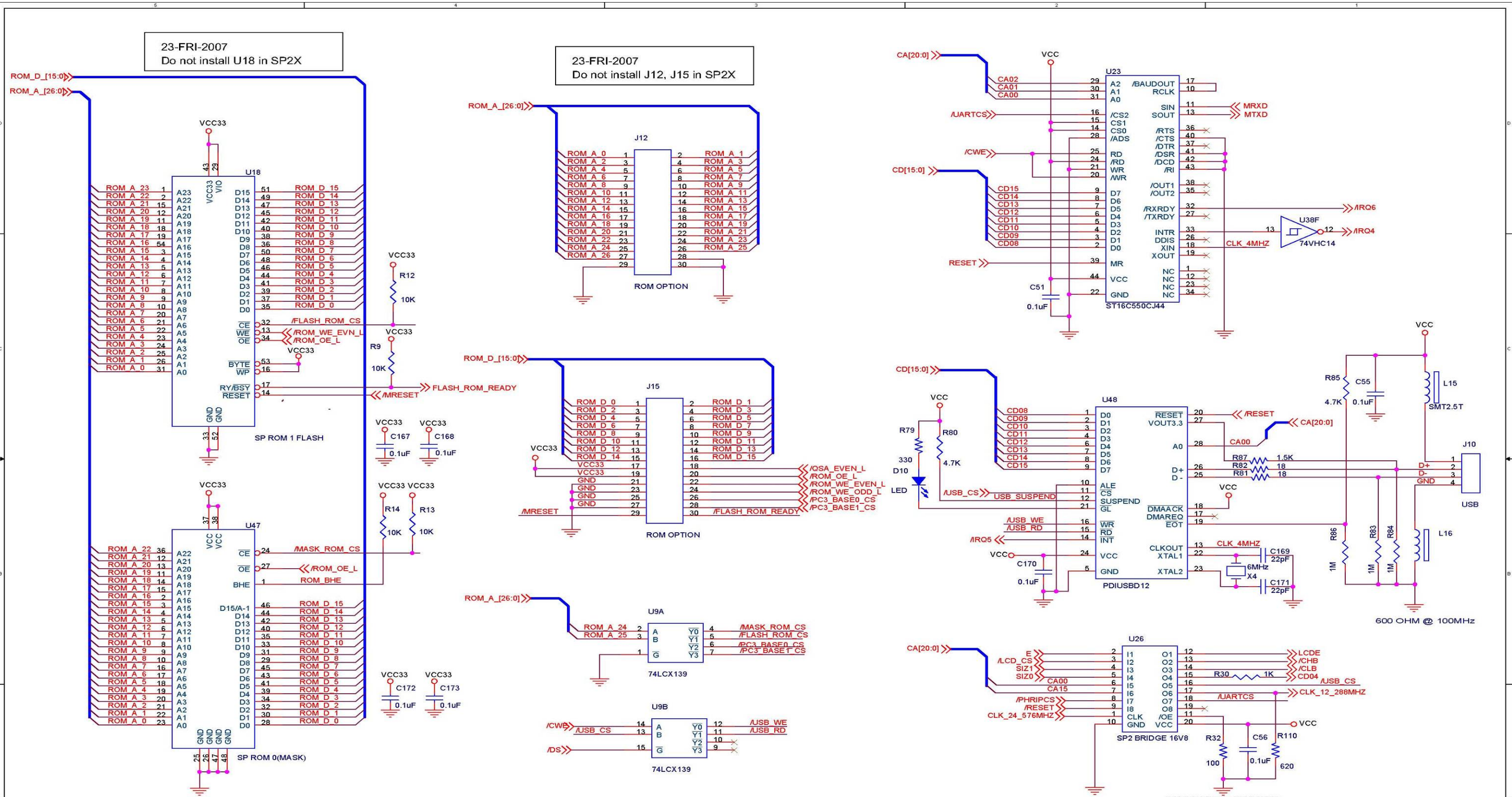

23-FRI-2007  
Do not install U18 in SP2X

23-FRI-2007  
Do not install J12, J15 in SP2X

SP2.BOM.Engine.REV3.VER3

**Young Chang R&D Institute**  
1432 Main St.  
Waltham MA 02451  
USA  
Copyright 2004 Young Chang Co., Ltd.  
Reproduction without the express written consent of Young Chang Co., Ltd. is prohibited.

Title: SP2 ENGINE BOARD ASSEMBLY  
SOUND ROM, UART, USB, BRIDGE

Size	By YG LIM	Document Number <Doc>	Rev RAV1
Date: Friday, February 23, 2007	Sheet 4	of 6	

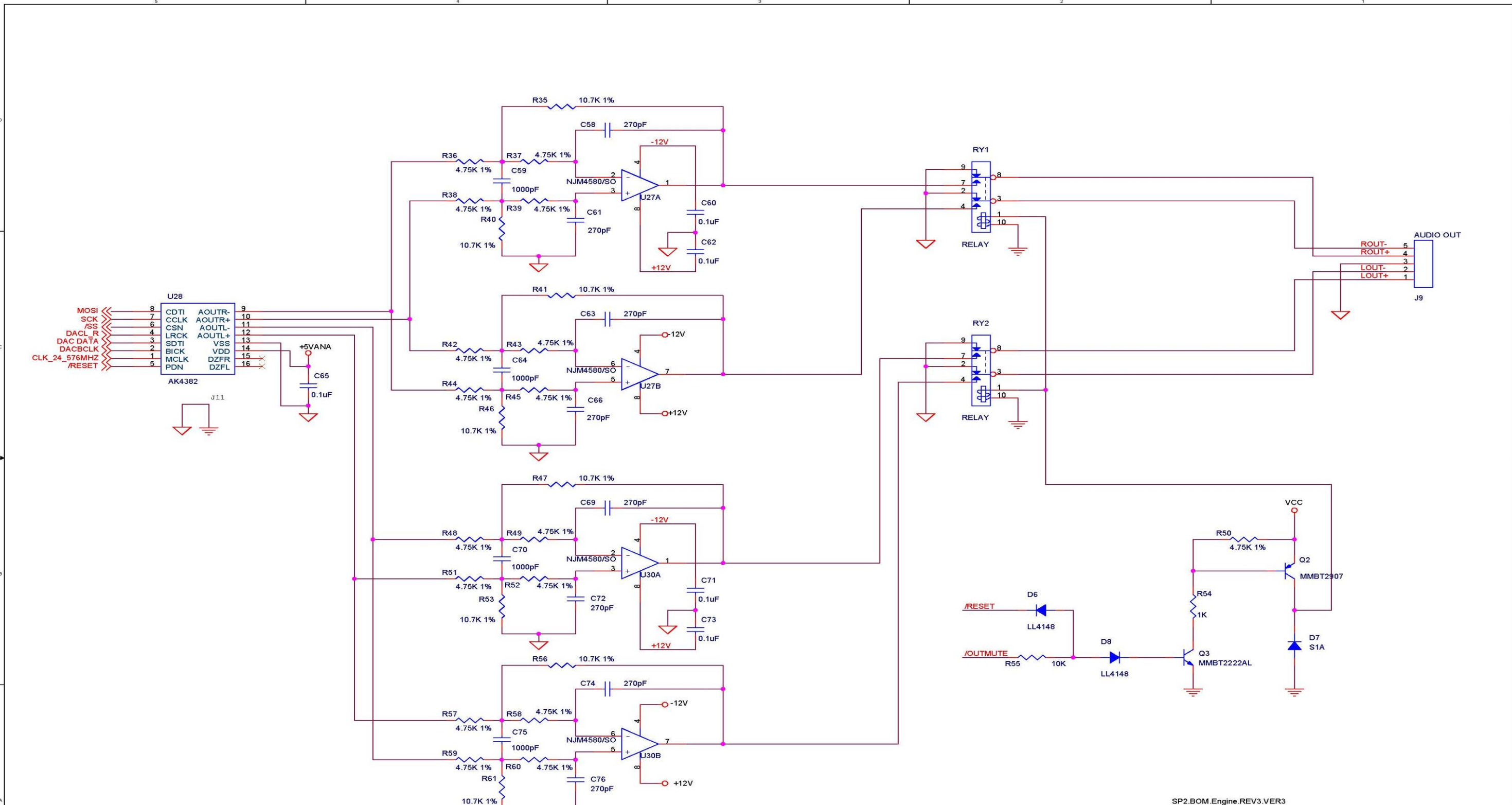

SP2.BOM.Engine.REV3.VER3

**Young Chang R&D Institute**  
 1432 Main St.  
 Waltham MA 02451  
 USA  
 Copyright 2004 Young Chang Co., Ltd.  
 Reproduction without the express written consent of Young Chang Co., Ltd. is prohibited

Title SP2 ENGINE BOARD ASSEMBLY  
 DAC

Size	By	Document Number	Rev
	YG LIM	<Doc>	RAV1
Date:	Friday, February 23, 2007	Sheet 5 of 6	



Place the oscilloscope power and ground test points below with approximately equal spacing around the board.

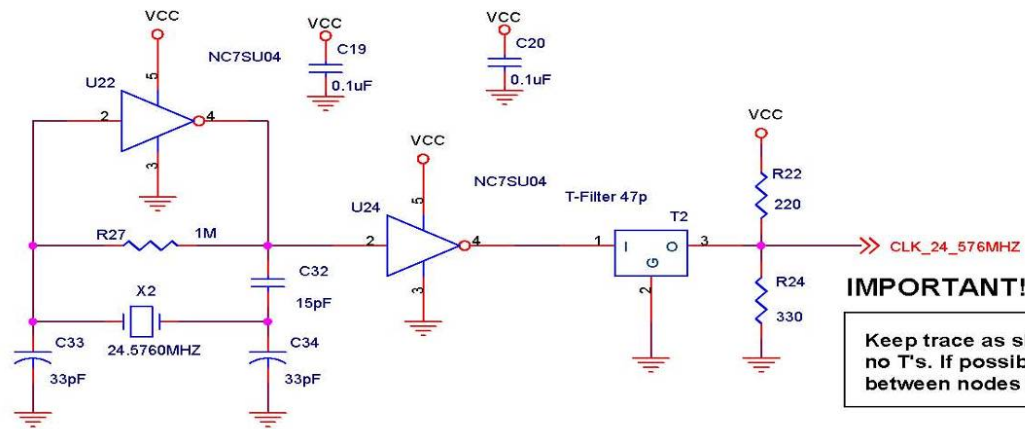
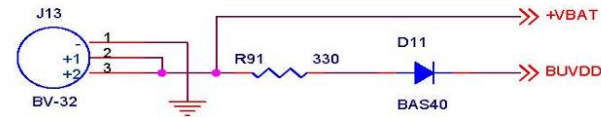
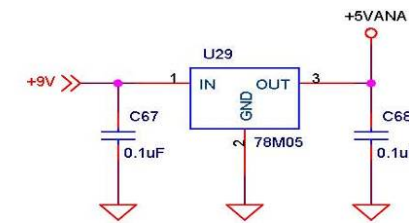
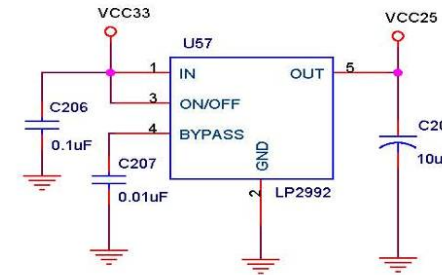
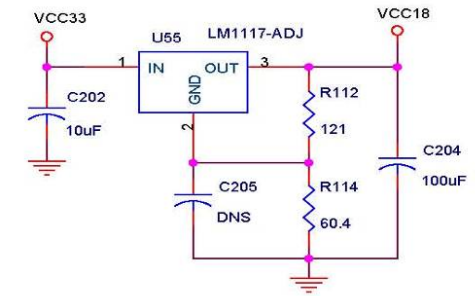
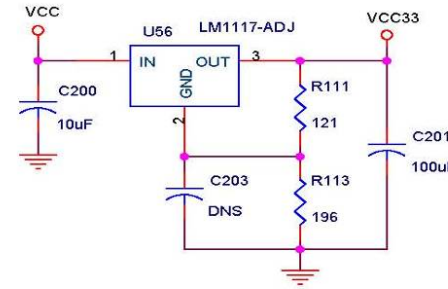
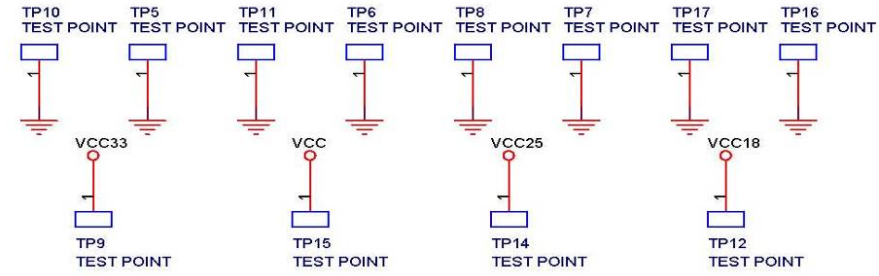

**IMPORTANT!**  
Keep trace as short as possible with no T's. If possible, keep distance between nodes equal.

SP2.BOM.Engine.REV3.VER3

**Young Chang R&D Institute**

1432 Main St.  
Waltham MA 02451  
USA  
Copyright 2004 Young Chang Co., Ltd.  
Reproduction without the express written consent of Young Chang Co., Ltd. is prohibited.

Title: SP2 ENGINE BOARD ASSEMBLY			
POWER, CLOCK, PLL			
Size	By	Document Number	Rev
	YG LIM	<Doc>	RAV1
Date:	Friday, February 23, 2007	Sheet	6 of 6

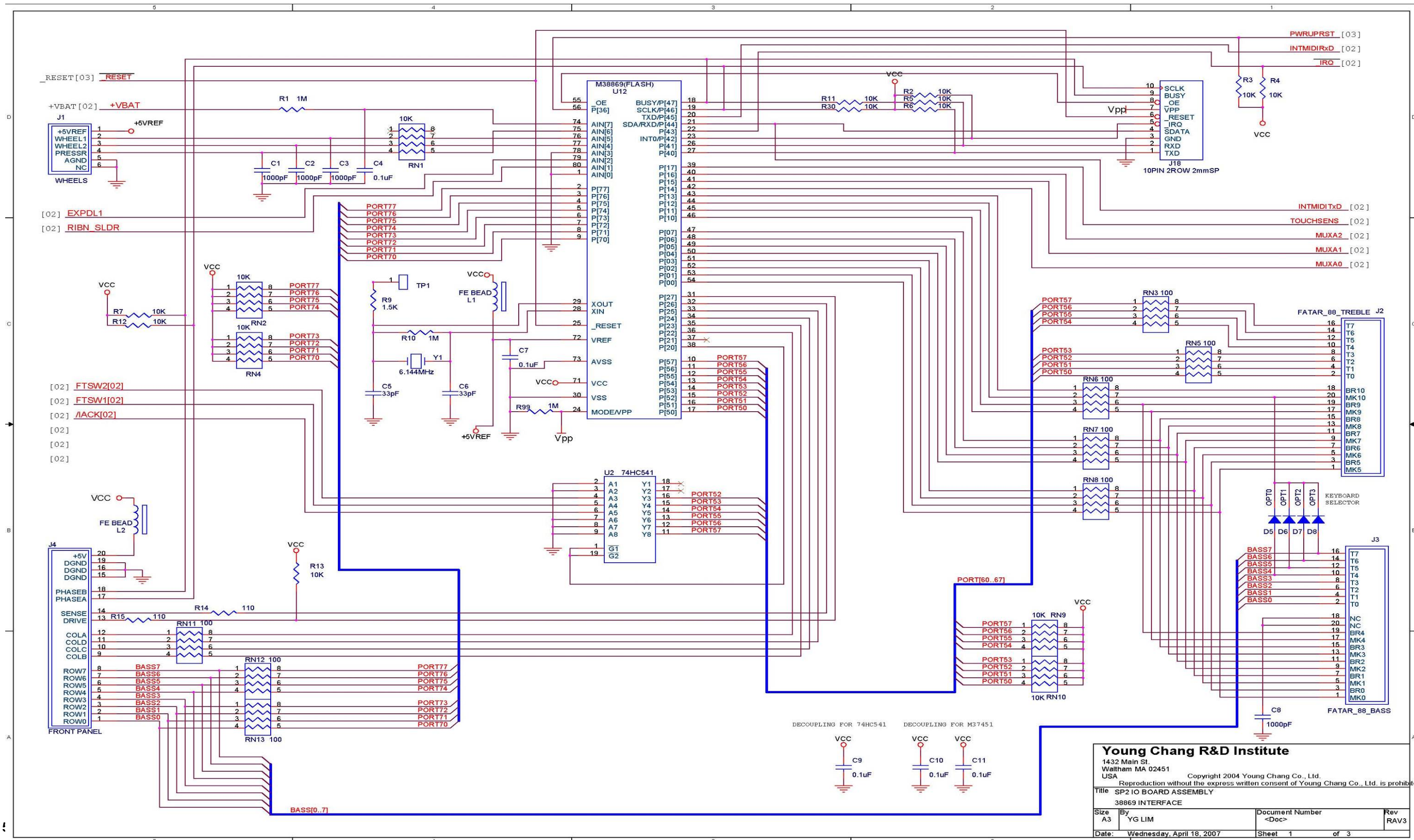

**Young Chang R&D Institute**  
 1432 Main St.  
 Waltham MA 02451  
 USA

Copyright 2004 Young Chang Co., Ltd.  
 Reproduction without the express written consent of Young Chang Co., Ltd. is prohibited.

Title: SP2 IO BOARD ASSEMBLY  
 38869 INTERFACE

Size: A3	By: YG LIM	Document Number: <Doc>	Rev: RAV3
Date: Wednesday, April 18, 2007	Sheet: 1	of: 3	



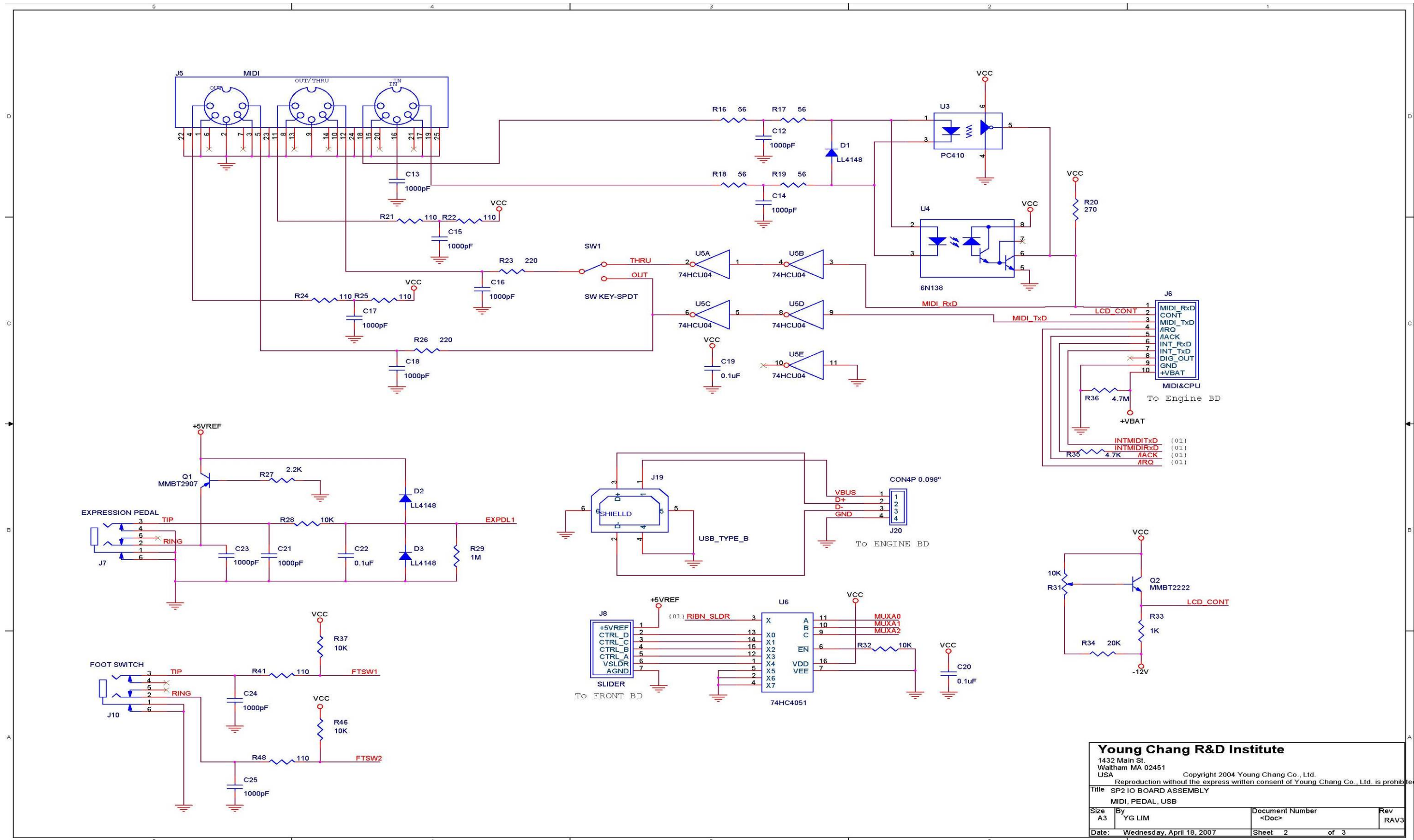

**Young Chang R&D Institute**  
 1432 Main St.  
 Waltham MA 02451  
 USA  
 Copyright 2004 Young Chang Co., Ltd.  
 Reproduction without the express written consent of Young Chang Co., Ltd. is prohibited.

Title: SP2 IO BOARD ASSEMBLY  
 MIDI, PEDAL, USB

Size A3	By YG LIM	Document Number <Doc>	Rev RAV3
Date: Wednesday, April 18, 2007	Sheet 2	of 3	

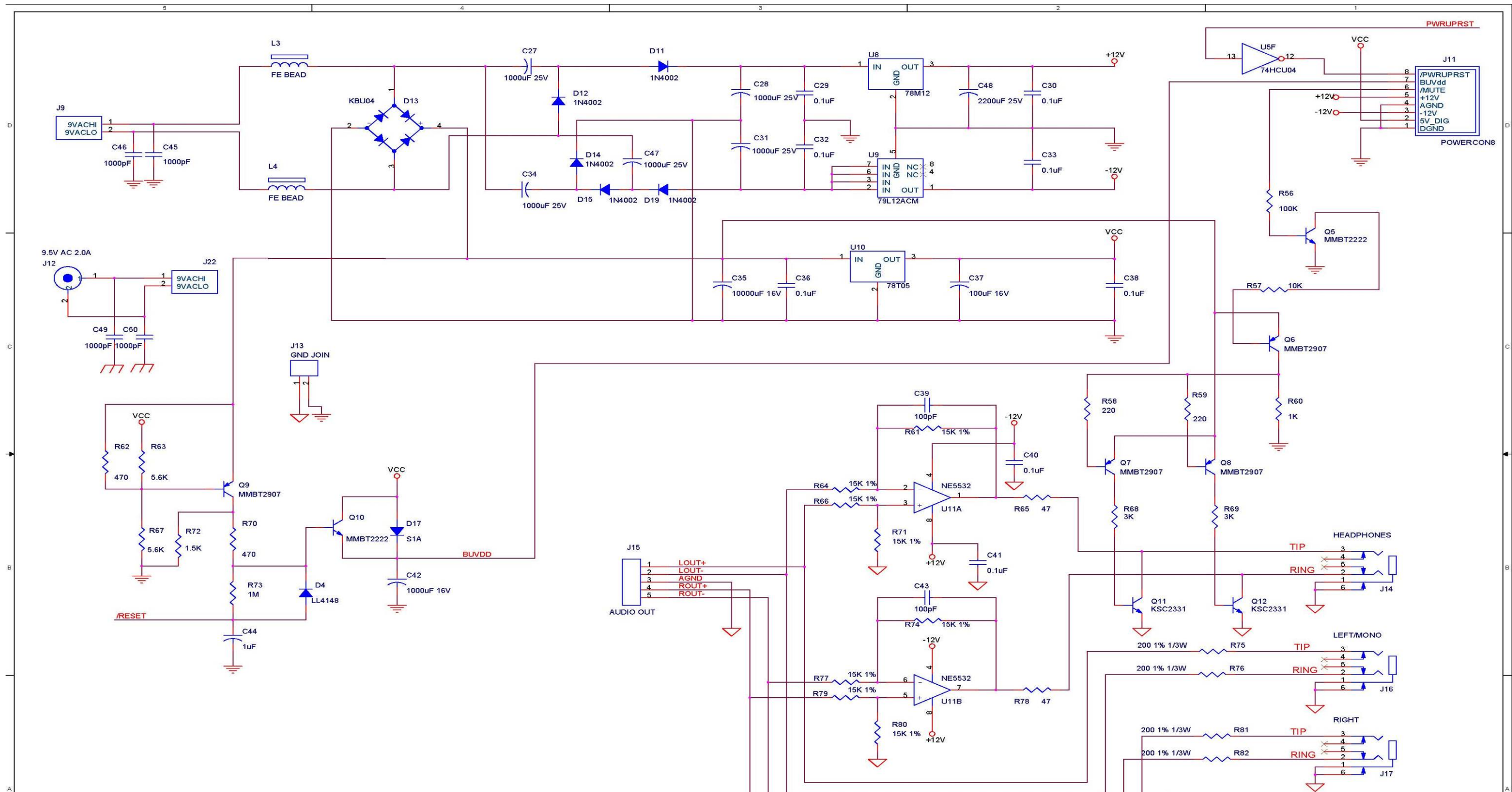

**Young Chang R&D Institute**  
 1432 Main St.  
 Waltham MA 02451  
 USA

Copyright 2004 Young Chang Co., Ltd.  
 Reproduction without the express written consent of Young Chang Co., Ltd. is prohibited.

Title: SP2 IO BOARD ASSEMBLY  
 POWER, RESET, HEADPHONE

Size A3	By YG LIM	Document Number <Doc>	Rev RAV3
Date: Wednesday, April 18, 2007	Sheet 3	of 3	





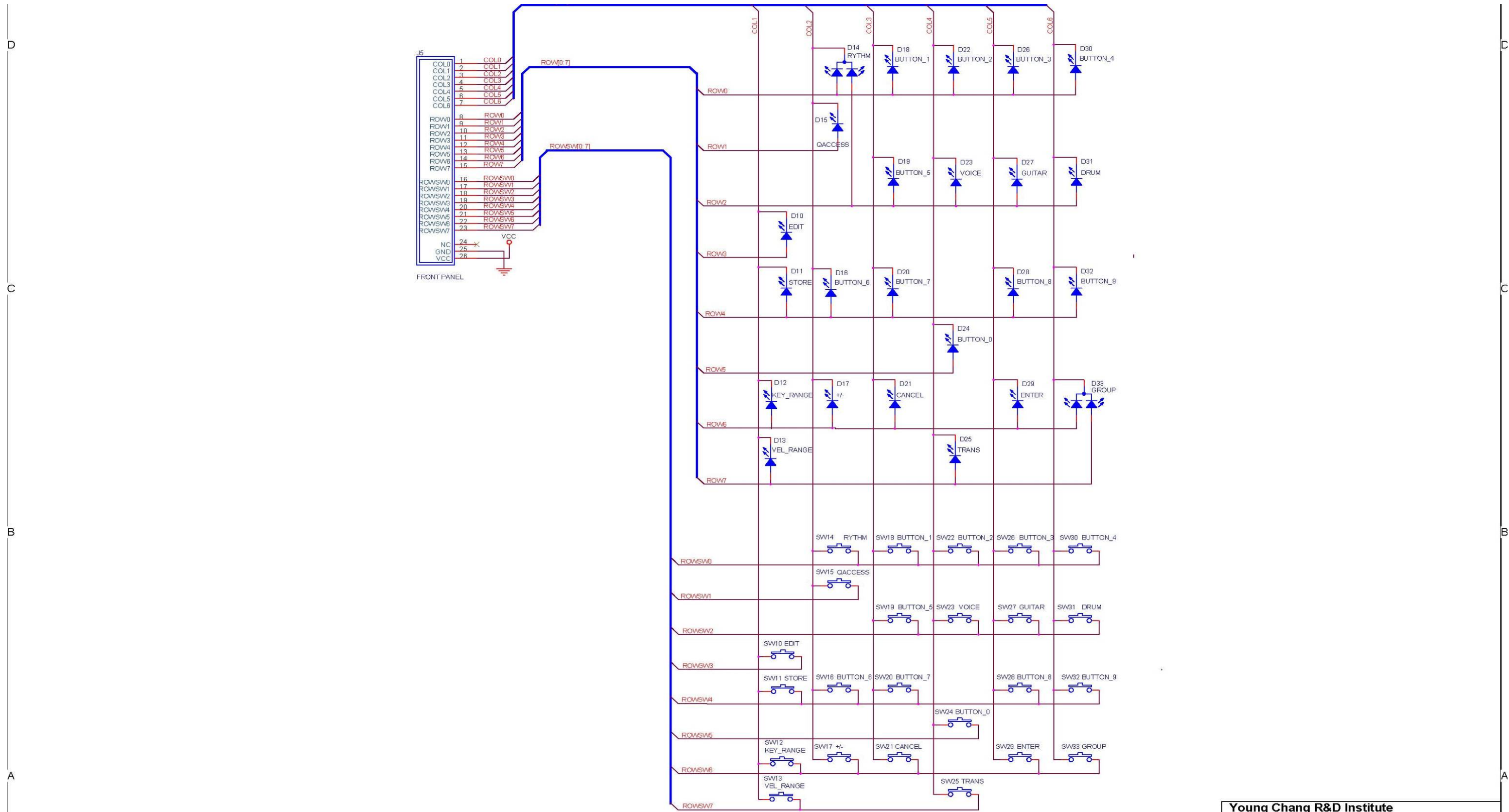

**Young Chang R&D Institute**  
 1432 Main St.  
 Waltham MA 02451  
 USA

Copyright 2004 Young Chang Co., Ltd.  
 Reproduction without the express written consent of Young Chang Co., Ltd. is prohibited.

Title: SP2 FRONT BOARD ASSEMBLY  
 FRONT PANEL RIGHT

Size	By	Document Number	Rev
Custom	YG LIM	<Doc>	RAV2
Date:	Thursday, March 08, 2007	Sheet 1 of 2	