



Service Manual

lexicon

Safety Suggestions

Read Instructions Read all safety and operating instructions before operating the unit.

Retain Instructions Keep the safety and operating instructions for future reference.

Heed Warnings Adhere to all warnings on the unit and in the operating instructions.

Follow Instructions Follow operating and use instructions.

Heat Keep the unit away from heat sources such as radiators, heat registers, stoves, etc., including amplifiers which produce heat.

Ventilation Make sure that the location or position of the unit does not interfere with its proper ventilation. For example, the unit should not be situated on a bed, sofa, rug, or similar surface that may block the ventilation openings; or, placed in a cabinet which impedes the flow of air through the ventilation openings.

Wall or Ceiling Mounting Do not mount the unit to a wall or ceiling except as recommended by the manufacturer.

Power Sources Connect the unit only to a power supply of the type described in the operating instructions, or as marked on the unit.

Grounding or Polarization* Take precautions not to defeat the grounding or polarization of the unit's power cord.

*Not applicable in Canada.

Power Cord Protection Route power supply cords so that they are not likely to be walked on or pinched by items placed on or against them, paying particular attention to cords at plugs, convenience receptacles, and the point at which they exit from the unit.

Nonuse Periods Unplug the power cord of the unit from the outlet when the unit is to be left unused for a long period of time.

Water and Moisture Do not use the unit near water — for example, near a sink, in a wet basement, near a swimming pool, near an open window, etc.

Object and liquid entry Do not allow objects to fall or liquids to be spilled into the enclosure through openings.

Cleaning The unit should be cleaned only as recommended by the manufacturer.

Servicing Do not attempt any service beyond that described in the operating instructions. Refer all other service needs to qualified service personnel.

Damage requiring service The unit should be serviced by qualified service personnel when:

the power supply cord or the plug has been damaged, objects have fallen, or liquid has been spilled into the unit,

the unit has been exposed to rain,

the unit does not appear to operate normally or exhibits a marked change in performance,

the unit has been dropped, or the enclosure damaged.

Outdoor Antenna Grounding If an outside antenna is connected to the receiver, be sure the antenna system is grounded so as to provide some protection against voltage surges and built-up static charges. Section 810 of the National Electrical Code, ANSI/NFPA No. 70-1984, provides information with respect to proper grounding of the mast and supporting structure, grounding of the lead-in wire to an antenna-discharge unit, size of grounding conductors, location of antenna-discharge unit, connection to grounding electrodes, and requirements for the grounding electrode. See figure below.

Power Lines An outside antenna should be located away from power lines.

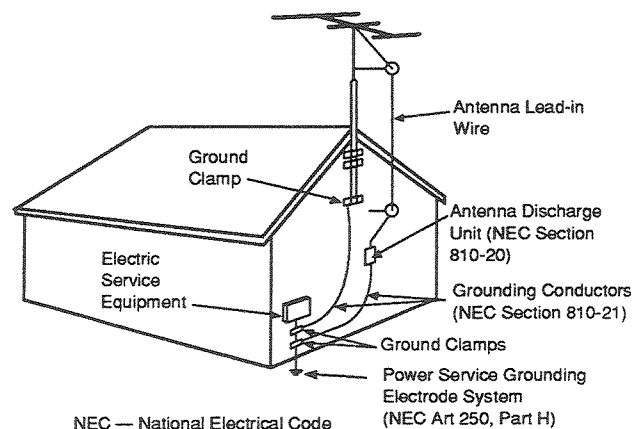

SAFETY SUMMARY

The following general safety precautions must be observed during all phases of operation, service and repair of this instrument. Failure to comply with these precautions, or with specific warnings elsewhere in these instructions violates safety standards of design manufacture and intended use of the instrument. Lexicon assumes no liability for the customer's failure to comply with these requirements.

GROUND THE INSTRUMENT

To minimize shock hazard the instrument chassis and cabinet must be connected to an electrical ground. The instrument is equipped with a three-conductor AC power cable. The power cable must either be plugged into an approved three-contact electrical outlet or used with a three-contact to two-contact adapter with the grounding wire (green) firmly connected to an electrical ground (safety ground) at the power outlet. The power jack and mating plug of the power cable meet International Electrotechnical Commission (IEC) safety standards.

DO NOT OPERATE IN AN EXPLOSIVE ATMOSPHERE

Do not operate the instrument in the presence of flammable gases or fumes. Operation of any electrical instrument in such an environment constitutes a definite safety hazard.

KEEP AWAY FROM LIVE CIRCUITS

Operating personnel must not remove instrument covers. Component replacement and internal adjustments must be made by qualified maintenance personnel. Do not replace components with power cable connected. Under certain conditions, dangerous voltages may exist even with the power cable removed. To avoid injuries, always disconnect power and discharge circuits before touching them.

DO NOT SERVICE OR ADJUST ALONE

Do not attempt internal service or adjustment unless another person, capable of rendering first aid and resuscitation, is present.

DO NOT SUBSTITUTE PARTS OR MODIFY INSTRUMENT

Because of the danger of introducing additional hazards, do not install substitute parts or perform any unauthorized modification to the instrument.

DANGEROUS PROCEDURE WARNINGS

Warnings, such as the example below, precede potentially dangerous procedures throughout this manual. Instructions contained in the warnings must be followed.

WARNING

Dangerous voltages, capable of causing death, are present in this instrument. Use extreme caution when handling, testing and adjusting.

SAFETY SYMBOLS

General definitions of safety symbols used on equipment or in manuals.



Instruction manual symbol: the product will be marked with this symbol when it is necessary for the user to refer to the instruction manual in order to protect against damage to the instrument.



Indicates dangerous voltage. (Terminals fed from the interior by voltage exceeding 1000 volts must be so marked.)

WARNING

The WARNING sign denotes a hazard. It calls attention to a procedure, practice, condition or the like which, if not correctly performed or adhered to, could result in injury or death to personnel.

CAUTION

The CAUTION sign denotes a hazard. It calls attention to an operating procedure, practice, condition or the like which, if not correctly performed or adhered to, could result in damage to or destruction of part or all of the product.

NOTE:

The NOTE sign denotes important information. It calls attention to procedure, practice, condition or the like which is essential to highlight.



CAUTION

Electrostatic Discharge (ESD) Precautions

The following practices minimize possible damage to ICs resulting from electrostatic discharge or improper insertion.

- Keep parts in original containers until ready for use.
- Avoid having plastic, vinyl or styrofoam in the work area.
- Wear an anti-static wrist-strap.
- Discharge personal static before handling devices.
- Remove and insert boards with care.
- When removing boards, handle only by non-conductive surfaces and never touch open-edge connectors except at a static-free workstation.*
- Minimize handling of ICs.
- Handle each IC by its body.
- Do not slide ICs or boards over any surface.
- Insert ICs with the proper orientation, and watch for bent pins on ICs.
- Use anti-static containers for handling and transport.

*To make a plastic-laminated workbench anti-static, wash with a solution of Lux liquid detergent, and allow to dry without rinsing.

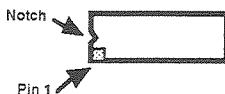

CAUTION

ICs inserted backwards will be destroyed. Incorrect insertion of ICs is also likely to cause damage to the board.



Service Manual

lexicon



Table of Contents

1. Vortex Controls and Connectors	
Front Panel.....	1-1
Setting Audio Levels • Setting MIX Values	
Rear Panel	1-2
Footswitch and Footpedal Connections • Headphones	
Audio Connections	1-3
In-Line Processing • Using Vortex on a Mixer	
Effects Return Bus	
Periodic Maintenance	1-4
Ordering parts	1-4
Returning units for service	1-5
2. Specifications	
3. Performance Verification	
Block Diagram	3-1
Required Equipment	3-1
Initial Inspection	3-2
Power Up	3-2
Functional Tests	3-3
Diagnostics	3-7
Individual Test Descriptions	3-10
Listening Test	3-14
Shock Test	3-14
Audio Performance Test	3-15
Disassembly/Reassembly	3-17
Troubleshooting Tree	3-18
4. Theory of Operation	
Analog I/O	4-1
Processor	4-3
I/O	4-5
Power Supply	4-6
CODEC/DSP Serial I/O Timing	4-7
DRAM State Machine	4-7
5. Parts List	
6. Schematics and Assembly Drawings	



1 Controls and Connectors

The Front Panel

PEDAL/TAP

If a footpedal is connected, assigns footpedal control to any parameter selected by Parameter knob (except *ECHO 1+* and *ECHO 2+*). LED indicates pedal assignment.

When no pedal is connected, or whenever Parameter knob is set to *ECHO 1+* or *ECHO 2+*, button enters timing information. Two pushes define a tempo for all effects. LED indicates 1st TAP received, waiting for 2nd TAP.

STORE

Stores the current effect to whatever register is indicated by settings of A/B and REGISTER/PRESET.

CLEAR

Clears register pairs (A and B) to allow effects to be skipped for a footswitch step sequence, or footswitch-activated chains to be created. Repeat to restore the register pair.

A/B

Activates rear panel A/B relay, and toggles selection of A and B banks of presets and registers. A and B LEDs indicate current selection.

VALUE

Adjusts values of selected parameter. All parameter values are displayed with a range of 1-64 and are accompanied by the VALUE LED.

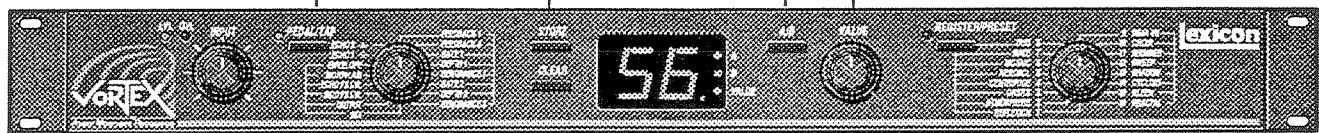

INPUT

Sets the level of the incoming signal. LEDs indicate acceptable signal level (LVL), and overload (OVL).

PARAMETER

Selects among 16 parameters for adjustment with the VALUE knob, or pedal assignment.

DISPLAY

Numeric display of digits 1-64, and decimal point. Displayed digits indicate ID number of currently running effect. Digits accompanied by lit VALUE LED indicate parameter values. Decimal point lights to show an effect has been modified since it was stored.

REGISTER/PRESET

Button selects preset or register mode. LED lights when register mode is selected, turns off in preset mode. Knob will select presets 1-16 or registers 1-16, depending on button setting.

Note using a footswitch to step through registers will cause a discrepancy between the REGISTER/PRESET knob setting and the display (which will show the number of the register that is actually running.)

1. Turn Vortex INPUT all the way down (fully counter-clockwise).
2. Connect Vortex inputs to an audio source, and Vortex outputs to an amplifier or mixer.
3. Apply an input signal at a level that you typically use.
4. While sending audio to Vortex, gradually turn up the INPUT control until the LVL LED* lights green. Continue to advance INPUT until the OVL LED lights on only the loudest peaks. If the OVL LED is lit continuously, turn the INPUT control down.
5. Adjust amplifier or mixer levels for optimum signal-to-noise performance.

* The LVL LED is off when the incoming signal is low; it lights to indicate acceptable levels (6dB to 30dB below overload). The OVL LED lights red when the signal approaches overload. Acceptable signals will light the LVL LED almost continuously, and the OVL LED only on peaks.

Setting Audio Levels

The sound of each Vortex preset is highly dependent on the mix of dry (unprocessed) and wet (processed) signals. MIX settings are stored with each effect. If Vortex outputs are connected to amplifier or mixer channel inputs, you should not have to adjust this parameter to use any of the presets. If Vortex outputs are connected to a console's returns (and Vortex output is, therefore, mixed with dry signal from the console), you should select each effect and raise the MIX parameter to its maximum value (64=100% wet). Be aware that several Vortex effects are meant to be used at 100% wet (*ORBITS*, *CENTRIFUGE*, *MOSAIC*, etc.). When using Vortex with a console, you will get the strongest effect by connecting Vortex outputs to channel inputs.

Setting MIX Values

The Rear Panel

A/B
Relay-switched Tip/Ring/Sleeve phone output for remote channel switching of musical instrument amps via front panel or footswitch A/B control.

FOOTPEDAL
Tip/Ring/Sleeve 1/4" phone input for expression pedal control of selected parameter.

OUTPUT
Single-ended (unbalanced) stereo outputs provide -2dBu nominal output level. Use the right output connector for mono output. If no connection is made at the right output, the left output can be used to drive high-efficiency headphones at modest volume.

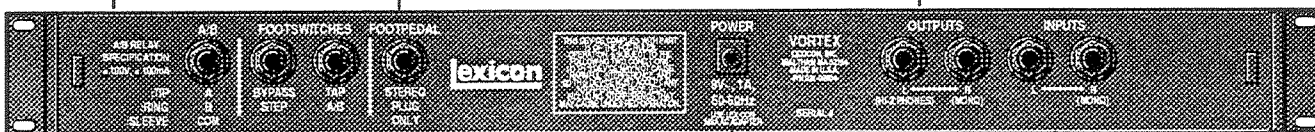

FOOTSWITCHES
Two Tip/Ring/Sleeve phone inputs, for momentary contact footswitches, allow footswitch control of front panel functions.

POWER
Use Lexicon MSA power pack, or 9VAC 1 amp equivalent.

INPUT
Single-ended (unbalanced) inputs accept levels as low as -30dBu. Input impedance is 50 kΩ in stereo, 25 kΩ in mono. Use the right for mono input.

Footswitch and Footpedal Connections

Footswitches connected via the rear-panel footswitch jacks allow control of register STEP and BYPASS functions and/or TAP and A/B effect morphing. Two momentary footswitches can be wired to a tip-ring-sleeve connector. A stereo Y-connector allows two identical single switches to be used.

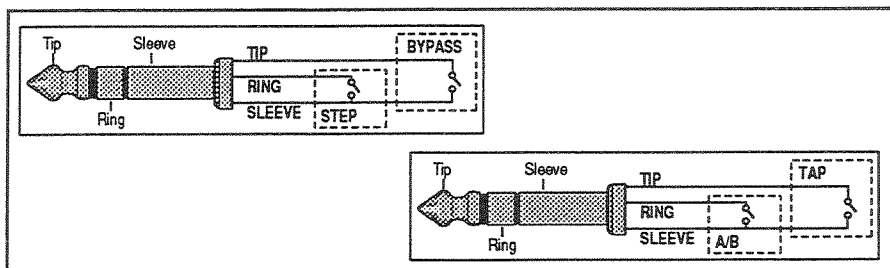

An expression pedal connected via the rear panel pedal jack allows continuous control of a selected front panel parameter.

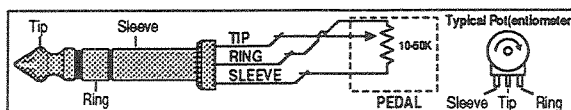

Headphones

A stereo signal which is adequate to drive high-efficiency headphones is available at the left output, *provided no connections are made through the right output*. This feature is provided as a convenience for practice purposes, and is intended to provide only modest volume.

Audio connections to Vortex are unbalanced and should be made with high quality shielded cables with 1/4" tip-sleeve phone jacks at the Vortex end.

Audio Connections

Vortex is a true stereo processor. Left and right inputs are processed separately. The chart below shows the processing path of each preset.

Even if you are using a mono input, take advantage of the stereo outputs. All Vortex effects are designed to be mono compatible and to maximize the spatial characteristics of each effect. If mono output is required, use the right output jack. The left and right signals are summed internally when only the right output is used.

	Stereo In Stereo Out	Dual Stereo In Stereo Out	Dual Mono In Stereo Out	Dual Mono In Dual Mono Out	Mono In Stereo Out
1	Reflexion A/B				
2	Atmosphere A/B				
3			Orbits A/B		
4					Centrifuge A/B
5	Aerosol A/B				
6	Mosaic A				Mosaic B
7		Maze B			Maze A
8			Duo B	Duo A	
9	Deja Vu A/B				
10	Choir A				Choir B
11	Shimmer A/B				
12	Sweep A/B				
13		Shadow A			Shadow B
14	Cycloid A/B				
15	Bleen A	Bleen B			
16	Fractal A/B				

Note that MIX settings are stored with Vortex effects. The presets have been designed with specific MIX settings for each effect which should not need adjustment when the unit is used in-line.

In-Line Processing

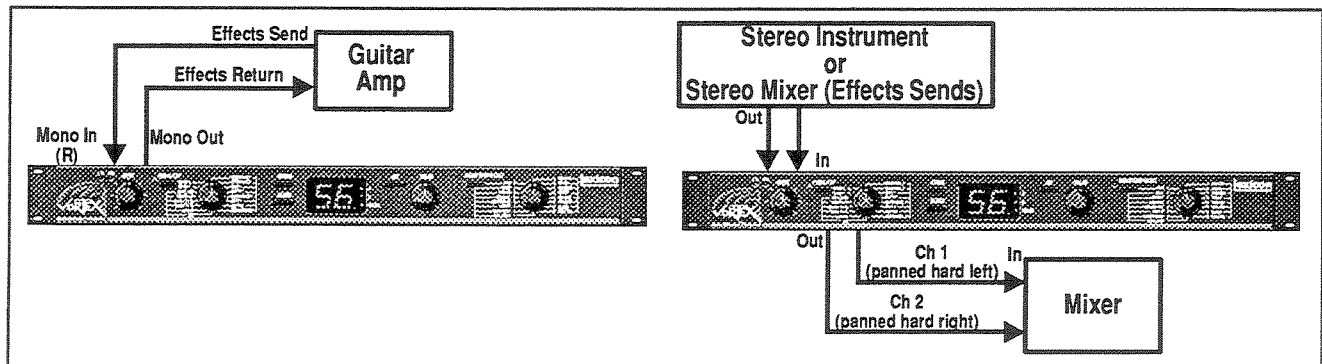

If Vortex is using a console's returns, select each effect's MIX parameter, then use the VALUE knob to set it to its maximum value (64).

Using Vortex on a Mixer Effects Return Bus

Some Vortex effects are meant to be heard 100% wet, with no dry signal added. Adjust your console's wet/dry mix accordingly.

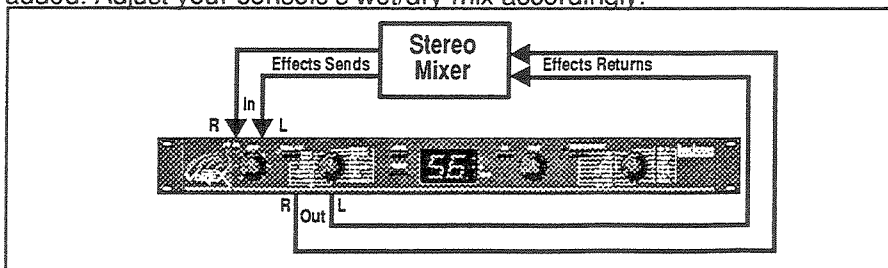

A/B Relay Switch

Vortex is equipped with an electrically isolated analog switch that allows remote control of guitar amplifier lead/rhythm channel selection. Simply connect a standard 1/4" guitar cable between the Vortex rear panel A/B relay switch and the A/B switching input on your amp.

Both the front panel A/B button, and the footswitch A/B control will activate this switch, allowing simultaneous switching of effects and amplifier settings.

For example, if your amp channel A corresponds to lead, and channel B to rhythm, you can load Vortex's A registers with effects you want to use on leads, and load the B registers with rhythm effects. Now, a single tap on the A/B footswitch will coordinate switching between lead effects on your A channel and rhythm effects on your B channel.

Any amplifier with a channel switching feature and a footswitch connection can be connected to the rear panel A/B relay connector on Vortex. The switch functions as follows:

	Mono plug*	Stereo plug
A	switch closed	sleeve tied to Tip
B	switch open	sleeve tied to Ring

* To reverse polarity, use a stereo plug into Vortex, with a mono plug going into the amp. Attach the two wires to the connector sleeve and ring so that A = open and B = closed.

Periodic Maintenance

Under normal conditions Vortex requires minimal maintenance. Use a soft, lint-free cloth slightly dampened with warm water and a mild detergent to clean the exterior surfaces of the unit.

Do not use alcohol, benzene or acetone-based cleaners or any strong commercial cleaners.

Avoid using abrasive materials such as steel wool or metal polish. If the unit is exposed to a dusty environment, a vacuum or *low-pressure* blower may be used to remove dust from the unit's exterior.

Ordering Parts

When ordering parts, identify each part by type, value and Lexicon Part Number. Replacement parts can be ordered from:

Lexicon, Inc.
100 Beaver Street
Waltham MA 02154
Telephone: 617-736-0300
Fax: 617-891-0340

ATT: Customer Service

Before returning a unit, for warranty or non-warranty service, consult with Lexicon to determine the extent of the problem, and to obtain Return Authorization. No equipment will be accepted without Return Authorization from Lexicon.

Returning units for service

If you choose to return a Vortex to Lexicon for service, Lexicon assumes no responsibility for the unit in shipment from customer to the factory, whether the unit is in or out of warranty. All shipments must be well packed (using the original packing materials if possible), properly insured, and consigned to a reliable shipping agent.

When returning a unit for service, please include the following information:

- Name
- Company name
- Street address
- City, State, Zip Code, Country
- Telephone number (including Area Code)
- Serial number of unit
- Description of the problem
- Preferred method of return shipment
- Return Authorization #, both inside and outside of package

Please enclose a brief note describing conversations with Lexicon personnel and give the name and telephone number of the person directly responsible for maintaining the unit.

Do not include accessories such as manuals, cables, footswitches, etc. with the unit, unless specifically requested to do so by Lexicon Service personnel.

2 Specifications

Audio Inputs (2)

Level -30dBu minimum

Impedance stereo/50k Ω unbalanced
mono/25k Ω unbalanced

Audio Outputs (2)

Level -2dBu nominal
+8dBu maximum

Impedance 600 Ω unbalanced

Footswitch Connectors

Tip/Ring/Sleeve phone jacks (2) for:
Bypass and Register Step
Tap and A/B Selection

Footpedal Connector

Tip/Ring/Sleeve phone jack for Expression pedal
with stereo plug

A/B Relay

Tip/Ring/Sleeve phone jack, rated at $\leq 100\text{mA}$

Frequency Response

20Hz-14kHz, +1dB to -3dB

THD+N

<0.03% @ 1kHz

Dynamic Range

83dB typical, 20Hz-20kHz bandwidth

Conversion

Delta-Sigma modulation with 64x oversampling

Power Requirements

9VAC, 1A wall transformer provided

Dimensions

19"W x 1.75"H x 4"D (483 x 45 x 102mm)

Weight

Unit: 2 lbs, 12 oz (1.2kg)

Environment

Operating

Temperature 32° to 104°F (0° to 40°C)

Storage -20° to 170° F (-30° to 75°C)

Relative

Humidity 95% non-condensing

Specifications subject to change without notice.

3 Performance Verification

Vortex Block Diagram

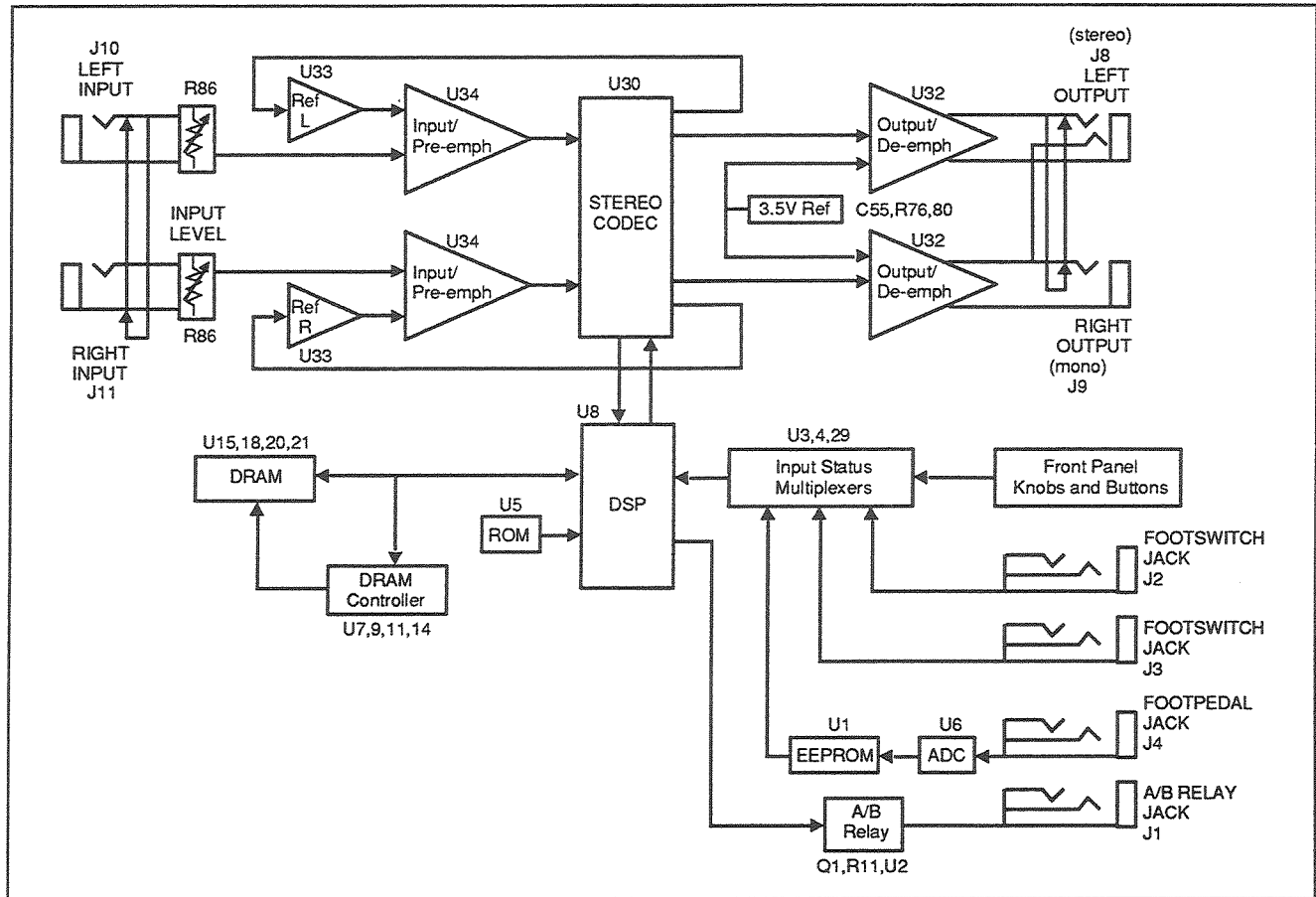

- Clean, antistatic, well lit work area
- Variac, 1 amp minimum
- 9VAC power supply 1 amp AC (Lexicon Part# 470-09650)
- Footpedal or potentiometer in the 10-50k range
- 1/4" to 1/4" stereo phone plug cable (3 ft. minimum) Switchcraft Part No. 10BK10 or equivalent
- Vortex Double Footswitch (Lex #750-09365) labeled A/B and TAP
- Vortex Double Footswitch (Lex #750-09365) labeled STEP and BYPASS
- Low Distortion Sine Wave Audio Oscillator
- THD+N Distortion Analyzer
- Stereo Headphones
- 2 Audio Cables unbalanced and shielded w/1/4" phone plug on one end and the appropriate connection on the other end to connect to the Audio Oscillator output
- Y connector for connecting the audio cables to the oscillator

Required Equipment

Initial Inspection

Inspect the unit for any obvious signs of physical damage. Verify that all front panel knobs operate smoothly and freely. Verify that all screws and rear panel jacks are secure and inspect the AC power supply for any sign of physical damage.

To start testing Vortex, it should be complete with cover and hardware.

Power Up

AC Current/Display Initialization

1. Set the Variac to 0VAC minimum.
2. Connect the 9VAC power supply to the isolated variable output of the Variac.
3. Connect the 9VAC power supply to the power input on Vortex.
4. Slowly increase Variac to 120VAC.
5. Verify the AC current draw is <0.12 Amps.

Normally, Vortex will run the following tests on power up:

- Display Test
- ROM Test
- DRAM Test
- CODEC Test

Verify that the position of the REGISTER/PRESET knob is displayed according to the table below.

REGISTER/PRESET Knob Position		Display
1	Reflection	1
2	Atmosphere	2
3	Orbits	3
4	Centrifuge	4
5	Aerosol	5
6	Mosaic	6
7	Maze	7
8	Duo	8
9	Deja Vu	9
10	Choir	10
11	Shimmer	11
12	Sweep	12
13	Shadow	13
14	Cycloid	14
15	Bleen	15
16	Fractal	16

Functional Tests

Using the 15 foot phone plug cables supplied, connect one cable between a footswitch to be used for A/B and TAP functions, and the Vortex rear panel connector labeled A/B/TAP.

Cable Connections

Connect the other cable between a footswitch to be used for STEP and BYPASS functions, and the rear panel connector labeled STEP/BYPASS.

1. Set PARAMETER, VALUE and the REGISTER/PRESET knob to a 6 o'clock position.
2. Power cycle Vortex while holding down both A/B and REGISTER/PRESET.
3. Verify that "d" appears on the display, then release the buttons.
4. Press REGISTER/PRESET and verify that the display reads "00".
5. Press REGISTER/PRESET again to enter the test. Verify that the display reads "0".
6. Turn each front panel knob clockwise, and verify that "1" is displayed.
7. Continue to turn each front panel knob clockwise, and verify that whenever all three knobs are in the same position, the display decimal point goes out. Also verify that, in this state, the display indicates the current position of the encoders in hexadecimal as shown below.

Encoder Test

REGISTER/PRESET Knob Position		Display
1	Reflection	0
2	Atmosphere	1
3	Orbits	2
4	Spin	3
5	Aerosol	4
6	Mosaic	5
7	Maze	6
8	Duo	7
9	Deja Vu	8
10	Choir	9
11	Shimmer	A
12	Sweep	b
13	Shadow	C
14	Cycloid	d
15	Bleen	E
16	Extreme	F

When the 3 knobs are in unlike positions, a decimal point will be displayed along with the current position of the REGISTER/PRESET knob (0-F).

When all three knobs are set to the same position, the decimal point will go off. To check the current position of the PARAMETER knob, press PEDAL/TAP. To check the current position of the VALUE knob, press A/B.

Press the REGISTER/PRESET button to exit the test, then verify that the display indicates the current position of the REGISTER/PRESET knob according to the following table.

REGISTER/PRESET		
Knob Position		Display
1	Reflection	00
2	Atmosphere	01
3	Orbits	02
4	Spin	03
5	Aerosol	04
6	Mosaic	05
7	Maze	06
8	Duo	07
9	Deja Vu	08
10	Choir	09
11	Shimmer	0A
12	Sweep	0b
13	Shadow	0C
14	Cycloid	0d
15	Bleen	0E
16	Extreme	0F

Button/Footswitch Test

1. Turn the REGISTER/PRESET knob until the display reads "01".
2. Press the REGISTER/PRESET button and verify that the display reads "0".
3. Individually press each button and footswitch and verify that the display indicates the correct value according to the table below. When no buttons are being tested, "0" should be displayed.

Front Panel Controls	Footswitches
PEDAL/TAP = 1	STEP = 6
STORE = 2	BYPASS = 7
CLEAR = 3	A/B = 8
A/B = 4	TAP = 9
REGISTER/PRESET = 5	

To exit the test, simultaneously press the A/B and REGISTER/PRESET buttons and verify that the display reads "01", (the current position of the REGISTER/PRESET knob).

Disconnect the footswitch cables from Vortex.

This test requires a pedal or manual potentiometer in the 10-50k range connected to the footpedal jack as illustrated on Page 1-2. Start with the pedal in the heel-down position (minimum resistance between tip and sleeve).

Footpedal Test

1. Turn the REGISTER/PRESET knob until the display reads "02".
2. Press the REGISTER/PRESET button. The display should show the 8-bit value of the footpedal voltage in hexadecimal, with "00" being the bottom of the scale, and "FF" being the top. Note that some footpedals will not make it to the top of the scale. This is acceptable, as long as they reach "FA".
3. With the pedal in the heel-down position, the display should read "00". Slowly move the pedal to the toe-down position. If no codes are missing, the display will show "PA" once the pedal has traveled its entire range.
4. Disconnect the stereo phone plug cable from the fixture and from Vortex.
5. Press the REGISTER/PRESET button for a display of "02".

1. Connect the 1/4" to 1/4" stereo phone plug cable between the Vortex A/B phone jack and the Vortex STEP/BYPASS phone jack.
2. Turn the REGISTER/PRESET knob until the display reads "03".
3. Press the REGISTER/PRESET button.
4. Verify that the display goes blank and that the A LED lights.
5. Press and hold the A/B button and verify that only the B LED lights.
6. Release the A/B button and verify that only the A LED lights.
7. Press the REGISTER/PRESET button for a display of "03".
8. Disconnect the 1/4" to 1/4" stereo phone plug cable from both Vortex jacks.

Relay Test

1. Turn the REGISTER/PRESET knob until the display reads "04".
2. Press the REGISTER/PRESET button, and verify that the display goes blank and the LVL LED lights.
3. Turn the REGISTER/PRESET clockwise 1 position at a time and verify that each LED and display segment lights individually.
4. When the REGISTER/PRESET LED lights, the test is finished.
5. Press the REGISTER/PRESET button to exit the test.

LED/Display Test

1. Turn the REGISTER/PRESET knob until the display reads "07".
2. Press the REGISTER/PRESET button. After approximately one second, verify that the display reads "PA".
3. Press the REGISTER/PRESET button for a display of "07".

DRAM Test

1. Turn the REGISTER/PRESET knob until the display reads "08".
2. Press the REGISTER/PRESET button. After approximately one second, verify that the display reads "PA".
3. Press the REGISTER/PRESET button for a display of "08".

ROM Test

EEPROM Initialize

1. Turn the REGISTER/PRESET knob until the display reads "0C".
2. Press the REGISTER/PRESET button. After approximately one second, verify that the display reads "PA".
3. Press the REGISTER/PRESET button for a display of "0C".

EEPROM Read/Write

1. Turn the REGISTER/PRESET knob until the display reads "0d".
2. Press the REGISTER/PRESET button. After approximately one second, verify that the display reads "PA".
3. Press the REGISTER/PRESET button for a display of "0d".

Resonator Test

1. Turn the REGISTER/PRESET knob until the display reads "0F".
2. Press the REGISTER/PRESET button. After approximately one second, verify that the display reads "PA".
3. Press the REGISTER/PRESET button for a display of "0F".
4. Power off Vortex.

There are two types of diagnostic software in Vortex: Power Up Diagnostics and User Diagnostics. Power Up Diagnostics are executed automatically each time the system is powered up; User Diagnostics are operator activated.

Diagnostics

On normal power up, Vortex automatically runs the following diagnostic tests in the sequence shown. During these tests the display will show all segments and LEDs lit except the OVL LED.

Power Up Diagnostics

Display Test
ROM Test
DRAM Test
Codec Test

If a failure occurs, Vortex will display "Er.". The REGISTER/PRESET button must be pressed to display which test failed. To display additional diagnostic information, follow the directions in the Pass/Fail Indicator section. For detailed information about the tests, consult the Individual Test Descriptions

User Diagnostics provide access to the tests run by Power Up Diagnostics and access to tests and troubleshooting tools which are not available in the normal operating software.

User Diagnostics

User Diagnostics are accessed by pressing and holding both the REGISTER/PRESET and the A/B buttons while powering up the unit. When the display indicates "d" for diagnostic mode, release the buttons. Press the REGISTER/PRESET button to display the position of the REGISTER/PRESET knob. (See table below.) Diagnostic tests are selected by turning the REGISTER/PRESET knob until the desired test number is indicated on the display, and then pressing the REGISTER/PRESET button.

REGISTER/PRESET			
Knob Setting	Display	Test	
1 Reflection	0	Encoder Switch	
2 Atmosphere	1	Switch test: front panel buttons and footswitches	
3 Orbits	2 *	Footpedal	
4 Centrifuge	3	Relay	
5 Aerosol	4	LED/Display	
6 Mosaic	5	Audio I/O for signal performance tests	
7 Maze	6	Diag. loop for burn in	
8 Duo	7*	DRAM (Dynamic RAM)	
9 Deja Vu	8*	ROM Checksum	
10 Choir	9	Exit Diagnostics	
11 Shimmer	A	Sinewave Generator L. Output	
12 Sweep	b	Sinewave Generator R. Output	
13 Shadow	C*	EEPROM Initialize	
14 Cycloid	d*	EEPROM Read/Write	
15 Bleen	E	EEPROM Read	
16 Fractal	F*	Resonator	

* A pass "PA" or error "Er." condition is signaled on the display when these tests are run.

Pass/Fail Indicator When a test with the asterisk (*) next to it has been run, a pass condition is indicated by "PA" on the display. To exit the passed test, press the REGISTER/PRESET button.

A failed condition is indicated by "Er." on the display. To store the diagnostic failure information and exit the test, press the REGISTER/PRESET button. The decimal point will light to indicate that diagnostic information has been temporarily stored. The number displayed is the POSITION number of the REGISTER/PRESET knob.

To diagnose the error, once the test results have been temporarily stored, turn PARAMETER to select MIX. Now, press PEDAL/TAP to display the number of the test that failed.

The PARAMETER knob is used to display specific information in addition to failed test numbers. This information is shown below.

TEST	MIX	OUTPUT/MOD	MOD FX LVL/ECHO FX LVL/MORPH	ENVELOPE/ECHO+1
AUDIO I/O	05	The display will: read 00 00	Input from Codec bits 49-64	Output to Codec bits 49-64
DRAM	07	Address	Data Written	Data Read
ROM	08	Checksum	Not Used	Not Used
EEPROM	0C or 0D	Address	Data Written	Data Read

DRAM or EEPROM Failure If a DRAM or EEPROM test failed, the OUTPUT and MODFXLVL positions are used to display the high and low address bytes respectively at the time of the failure. The ECHO FX LVL and MORPH A/B positions display the high and low data bytes written. The ENVELOPE and ECHO+1 positions display the high and low data bytes that were read back. The following is an example of a DRAM failure.

If Vortex fails a DRAM test, "Er." will be displayed. Perform the following:

1. Press the REGISTER/PRESET button. Vortex will go into Diagnostic mode and the display will indicate the number of the failed test. In this case, "07".
2. Set the PARAMETER knob to MIX. The display will indicate which test failed. In this case, test "07".
3. Set the PARAMETER knob to OUTPUT to view the high byte address, set it to MOD FX LVL to view the low byte address.
4. Set the PARAMETER knob to ECHO FX LVL to view the high byte data that was written. Record the value. Set PARAMETER to MORPH A/B to view the low byte data that was written. Record the value.
5. Set the PARAMETER knob to ENVELOPE to view the high byte data that was read. Record the value. Set PARAMETER to ECHO+1 to view the low byte data that was read. Record the value.
6. Convert the recorded data from HEX to Binary and compare the written and read values to determine which bit is at fault.

PARAMETER Knob Settings						
MIX	OUTPUT	MOD FX LVL	ECHO FX LVL	MORPH A/B	ENVELOPE	ECHO+1
Test #	High Byte	Low Byte	High Byte	Low Byte	High Byte	Low Byte
Display						
07	00	00	AA	AA	AA	Ab
	DRAM Address...		Data written		Data read	
	Binary Value		Binary Value		Binary Value	
	00000000 00000000		10101010 10101010		1010101010101011	
	Address 0000 0000 0000 0000					
	Write	1010 1010 1010 1010				
	Read	1010 1010 1010 1011				
		^ zero bit different				
	Problem: U15.2 bent, D0 open					

These steps can be followed whether there was a EEPROM Read/Write or EEPROM Initialization failure.

ROM Checksum Failure

If the ROM checksum test fails, OUTPUT and MODFXLVL display the high and low bytes of the incorrect checksum.

Resonator Failure

If the RESONATOR test fails, OUTPUT is used to view the HEX value that represents the incorrect clock cycle. See Individual Test Descriptions section for detailed information.

Codec Test Failure

If the Codec test fails, OUTPUT and MODFXLVL display the data received from bits 17-24 and 25-32 respectively. On this test, the display will read "00" when the PARAMETER knob is set to these positions. The ECHOFXLVL and MORPH A/B positions will display the data received from bits 49-56 and 57-64 . The ENVELOPE and ECHO+1 positions will display the data sent from bits 49-56 and 57-64. See Individual Test Descriptions section for detailed information.

Individual Test Descriptions

Note that the number in parenthesis (), following the test name is the Diagnostic mode display reading.

Encoder Test (0)

The encoder test provides a means for verifying the operation of the three encoders. It includes: correct encoder sequence, gray scale and encoder ID. The test program uses the display to read the ID and position of the switch respectively. When the switches are in different positions, the decimal point (.) will be displayed along with the current position of the REGISTER/PRESET switch in hexadecimal. When the PARAMETER and VALUE switch are set to the same position as the REGISTER/PRESET switch, the decimal point will go out. To check the current position of the PARAMETER switch, the PEDAL/TAP button must be pushed. To check the current position of the VALUE switch, the A/B button must be pushed.

Press REGISTER/PRESET to exit the test.

Footswitch/Button Test

This test checks all five front panel buttons and the four footswitch functions. Each button and footswitch has its own value assigned which will be displayed as it is tested. If no buttons or switches are being tested, "0" will be displayed. The following is a list of buttons and footswitches and their assigned values.

Front Panel		Footswitch	
PEDAL/TAP	1	STEP	6
STORE	2	BYPASS	7
CLEAR	3	A/B	8
A/B	4	TAP	9
REGISTER/PRESET	5	*Footpedal Connected	A

*When a footpedal is connected, "A" will be displayed. The buttons and footswitches can't be tested unless the footpedal is disconnected .

Press A/B and REGISTER/PRESET simultaneously to exit the test.

Footpedal (2)

Note: This test requires a special Test Fixture. We have provided information in the schematics section of this manual to aid qualified technical personnel in fabricating the fixture.

Press REGISTER/PRESET to exit the test.

A/B Relay Test (3)

This test verifies that both switches (A and B) in the relay are working. The LEDs can be lit at any given time.

Press REGISTER/PRESET to exit the test.

LED/Display Test (4)

This test checks the seven front panel LEDs and all fifteen display segments individually. Turn the REGISTER/PRESET knob clockwise to sequentially light the LEDs and display segments from left to right.

Press REGISTER/PRESET to exit the test.

Audio I/O Test Mode (5)

This test is used to check the specifications of the converter circuitry by passing the output of the A/D converter to the D/A converter without any signal processing. This test mode is used during audio signal performance tests.

Diagnostic Loop Test (6)

This test is a diagnostic sequencing utility that continuously runs the following tests until a test fails or power is removed from the unit.

- ROM Test (8)
- DRAM Test (7)
- Codec Test (5)

If a test fails, "Er." is displayed. Press the REGISTER/PRESET button to display error information.

Audio DRAM (Dynamic RAM) Test (7)

This test puts the ADSP2105 processor in a mode to verify that all the DRAMs (U15,18,20,21) are working. To test the DRAMs, the ADSP2105 processor will perform two tests: a data test and an address test. During the data test the processor will write "AAAA" (1010101010101010) into all of the memory locations and then read them back. It will repeat the process with "5555" (0101010101010101). For the address test, the processor will write a count into memory then read it back (i.e. 0000000000000001, 0000000000000010, 0000000000000011).

Press REGISTER/PRESET to exit the test.

ROM Test (8)

This test performs a checksum on the entire ROM, (Read Only Memory) (U8), and compares the total with a predetermined value stored in the ROM. This test checks the basic integrity of the data in the ROM and some of the address lines. If there are more serious problems, the test will not run.

Press REGISTER/PRESET to exit the test.

Exit Diagnostics (9)

This selection allows you to return to normal operating mode by pressing the REGISTER/PRESET button.

Left Channel Audio Output Test (A)

This test digitally generates a sinewave at the left audio output. It was created as an audio troubleshooting tool to verify if the analog input or analog output circuitry is faulty. The PARAMETER knob controls amplitude, the REGISTER/PRESET knob controls frequency, as shown below.

Knob Position	PARAMETER Amplitude(dB)	REGISTER/PRESET Frequency (Hz)
1	-60	122
2	-54	244
3	-48	366
4	-42	488
5	-36	610
6	-30	854
7	-27	1098
8	-24	1587
9	-21	2075
10	-18	3051
11	-15	4028
12	-12	5981
13	-9	8057
14	-6	10010
15	-3	12085
16	0	14038

Because the sinewave is digitally generated, the distortion at the output should be the lowest the system can produce (typical 0.01%).

Press REGISTER/PRESET to exit the test.

Right Channel Audio Output Test (B)

This test works the same as the Left Channel Audio Output Test except that this test generates a sinewave at the right audio output.

Press REGISTER/PRESET to exit the test.

EEPROM Test (non-destructive read/write) (C)

This test performs a non-destructive Read/Write test for the EEPROM. The test reads the contents of one memory location in the EEPROM, stores the original value, writes a test value to the memory location and then reads the test value back. If the test value is correct, then the original value is rewritten into the original location. The test then goes to the next memory location and repeats the procedure.

EEPROM Initialize (destructive) (D)

Performing this function enables the EEPROM for initialization and writes the 16 factory presets to the 16 user registers.

EEPROM (non-destructive Read) (E)

This test reads the entire contents of the EEPROM, calculates a checksum value and displays it on the front panel.

Resonator Test (F)

This Test measures the sample rate (controlled by the ceramic resonator) referenced to the ADSP2105 clock (controlled by the crystal). The sample period should take 320 clock cycles. If it takes less than 318, or more than 322, the test will display an error. The exact number of clock cycles in an interrupt is returned as a HEX number.

If a failure occurs, the Vortex will display "Er.". To display more information about the error, press the REGISTER/PRESET button to enter Diagnostic mode. Set PARAMETER to MIX. Press the PEDAL/TAP button and verify that the PEDAL LED is lit.

Set PARAMETER to OUTPUT to view the HEX value that represents the clock cycle as shown to the right.

HEX	CLOCK
85	325
84	324
83	323
82	322
81	321
80	320
7F	319
7E	318
7d	317
7C	316
7b	315

Codec Test

(This test is only run on power up.) It verifies that the CS4216 Codec (coder/decoder) Stereo A/D D/A converter is working. The test also checks to see if the Codec is synchronized with the ADSP2105. This is a loopback test and is performed by sending data from DO2 (digital output 2 at pin 38), back into DI2 (digital input at pin 34). The serial data of the Codec consists of 64 data bits per sub frame: 32 bits for the left channel and 32 bits for the right channel. The first 16 bits on each channel (1-16 on the left channel and 33-48 on the right channel) are the audio data bits. They are not checked during the test. On the left channel, bits 17-32 (left channel status bits) are checked. On the right channel, bits 49-64 (right channel status bits) are checked.

If there is a serious problem with the Codec, this test will not run. Instead, all the LEDs and display segments may remain lit when Vortex is powered on in normal operating mode. The exact failure mechanism depends on the extent of the problem.

If "Er." (Error) is indicated on the display during normal power up, and the display indicates that Codec Test (5) failed, refer to the earlier section on Codec Test Failure.

Listening Tests

Setup

1. Connect the stereo headphones to the Vortex Left Output.
2. Connect the 2 audio cables for the sinewave audio oscillator to the left and right inputs of Vortex and the Y connector. Connect the Y connector to the output of the sinewave audio oscillator.
3. Set Vortex INPUT fully counterclockwise.
4. Power on Vortex and the low distortion sinewave audio oscillator.
5. Input a 220Hz sinewave at -35dBV to the inputs of Vortex.
6. Turn the REGISTER/PRESET knob to select 4 CENTRIFUGE.
7. Put on the headphones.
8. Set INPUT to a comfortable listening level.

Smooth Pot

1. Sweep the input level pot over its entire range.
2. Verify that no pops, clicks or scratchiness are heard when turning the control.

Quick Listen

1. Vary the frequency on the oscillator.
2. Verify that no pops, clicks, buzz, or other audio artifacts are heard.

Shock Test

1. Lift each end of Vortex 4" off the bench, then release it.
To prevent damage to the unit, keep one corner touching the bench at all times.
2. Verify that there are no audio, display, or LED intermittents caused by this action.
3. Power off Vortex.

Audio Performance Tests

Unless otherwise stated, the following settings will be used for the audio performance tests:

Oscillator	Analyzer
WAVEFORM: SINE	FILTER: OFF
OUTPUT: UNBAL	BANDWIDTH: - 22Hz to 22kHz
- 25 Ω	INPUTS: 100K Ω (except GAIN=600 Ω)
FLOAT	

Oscillator and Analyzer Default Settings

1. Connect an appropriate cable between the oscillator output and the Vortex Left input.
2. Connect an appropriate cable between the analyzer input and the Vortex Left output.
3. Turn Vortex INPUT fully clockwise.
4. Power cycle Vortex while depressing the A/B and REGISTER/PRESET buttons.
5. Press the REGISTER/PRESET button.
6. Set the REGISTER/PRESET knob to select 6 MOSAIC.
7. Press the REGISTER/PRESET button, and verify that the display reads "5".

Setup

This test checks the input to output gain characteristics of the Vortex through its audio signal path.

Gain Test

1. Apply a 1kHz signal at -28dBV (into 600 Ω load analyzer BANDWIDTH filter off) to the Vortex Left input channel.
2. Set the scale on the distortion analyzer to measure +4dBV signal level.
3. Verify an output of .5dBV +/- 1dBm at the Left output of Vortex.
4. Connect the oscillator output to the Vortex Right input.
5. Connect the analyzer input to the Vortex Right output.
6. Verify an output of .5dBV +/- 1dBm at the Vortex Right output.

This test checks the signal to noise of Vortex through the audio signal path.

Signal-to-Noise Test

1. Set the scale on the distortion analyzer to measure -80dBV signal.
2. Disconnect the oscillator from the Vortex input or turn the oscillator off.
3. Verify that the noise floor is <76dBV and >100dBV.
4. Connect the oscillator output to the Vortex Left input.
5. Connect the analyzer input to the Vortex Left output.
6. Repeat the test, verifying the levels at the Vortex Left output.

1kHz THD+N Test

This test checks the THD+N at 1kHz limit through the audio signal path of Vortex.

1. Apply a 1kHz signal at -30dBV to the Vortex Left input channel.
2. Adjust the scale on the distortion analyzer to measure .05% THD+N.
3. Verify a distortion level <0.03% & >0.001% THD+N at the Vortex Left output.
4. Connect the oscillator output to the Vortex Right input.
5. Connect the analyzer input to the Vortex Right output.
6. Verify a distortion level <0.03% & >0.001% THD+N at the Vortex Right output.

10kHz THD+N Test

This test checks the THD+N at 10kHz, 12dBV below limit through the Vortex audio signal path.

1. Apply a 10kHz signal at -42dBV to the Vortex Left input channel.
2. Adjust the scale on the distortion analyzer to measure .1% THD+N.
3. Verify a distortion level <0.1% & >0.005% THD+N at the Vortex Left output.
4. Connect the oscillator output to the Vortex Right input.
5. Connect the analyzer input to the Vortex Right output.
6. Verify a distortion level <0.1% & >0.005% THD+N at the Vortex Right output.

Frequency Response Test

This test checks the frequency response of Vortex through the audio signal path at the following frequencies:

Frequency	Limit
14kHz	+1/-3dB
11kHz	+1/-1dB
8kHz	+1/-1dB
3kHz	+1/-1dB
100Hz	+1/-1dB
20Hz	+1/-3dB

1. Apply a -42dBV signal at 1kHz, with the analyzer BANDWIDTH filters off, to the Vortex Right input.
2. Set the scale on the distortion meter to measure +4dBV.
3. Use the output level at the Vortex Right output for the 0dB reference to check frequency response.
4. Verify that the signal level output is within the listed limit of the reference at the frequencies listed above.
5. Connect the oscillator output to the Vortex Left input.
6. Connect the analyzer input to the Vortex Left output.
7. Repeat the previous tests verifying levels for the Left output.

Disassembling the Unit

To disassemble the unit, use the following procedure:

1. Remove seven screws from the housing: one (1) from the rear panel, three (3) from the top, and three (3) from the bottom.
2. Carefully remove the unit's end caps, swinging them out by the rack ears.
3. Remove eight (8) plastic nuts from the jacks on the rear panel.
4. Hold the front panel, and carefully remove the cover.
5. To disattach the circuit board from the front panel:
 - Pull off the four (4) knobs on the front panel.
 - Remove the four (4) nuts and washers from the front panel.
 - Hold the unit face down, and carefully separate the circuit board assembly from the front panel.

NOTE: The buttons are loose and can fall out.

 - Carefully remove the buttons from the rear of the front panel.

Disassembly/ Reassembly

Reassembling the Unit

To reinstall the front panel and circuit board assembly:

1. Hold the front panel face down, and reinsert the buttons.
2. Continue to hold the front panel face down so as not to loosen the buttons. From the rear, carefully position the circuit board and insert it into the front panel. Replace the nut and washer on the input potentiometer and the REGISTER/PRESET encoder and hand tighten.
3. Replace the remaining encoder nuts and washers. Check for alignment, then tighten all nuts. Do not overtighten.
4. Replace the cover, being careful to align the jacks, and the power connector with the holes in the rear of the cover.
5. Replace the eight (8) plastic nuts on the jacks. Be careful not to overtighten these, as the nuts can strip the threads of the jacks.
6. Replace the single screw in the rear of the unit, but do not tighten it.
7. Install the two end caps by hooking the rear tab of each into each end of the cover.
8. Holding the end caps in place, install the six (6) remaining screws. Tighten the rear-panel screw next to the power connector.

NOTE: The end cap screws are longer than the others. Be sure to use these on the end caps, where they are needed to insure proper security of the end caps — not in the body of the unit where a long screw will make contact with the circuit board.

Removal and Installation of Components

From time to time, it may be necessary to replace pots, jacks, the display, or other components. When desoldering, be careful not to overheat the board, use all caution to prevent damage to the circuit board, traces and pads.

When installing pots, jacks or displays, make sure that they are mechanically flush with the circuit board prior to soldering in place. If not properly aligned, stress can be placed on the new components and the board — resulting in early failure of the board and/or component.

Vortex Troubleshooting Tree

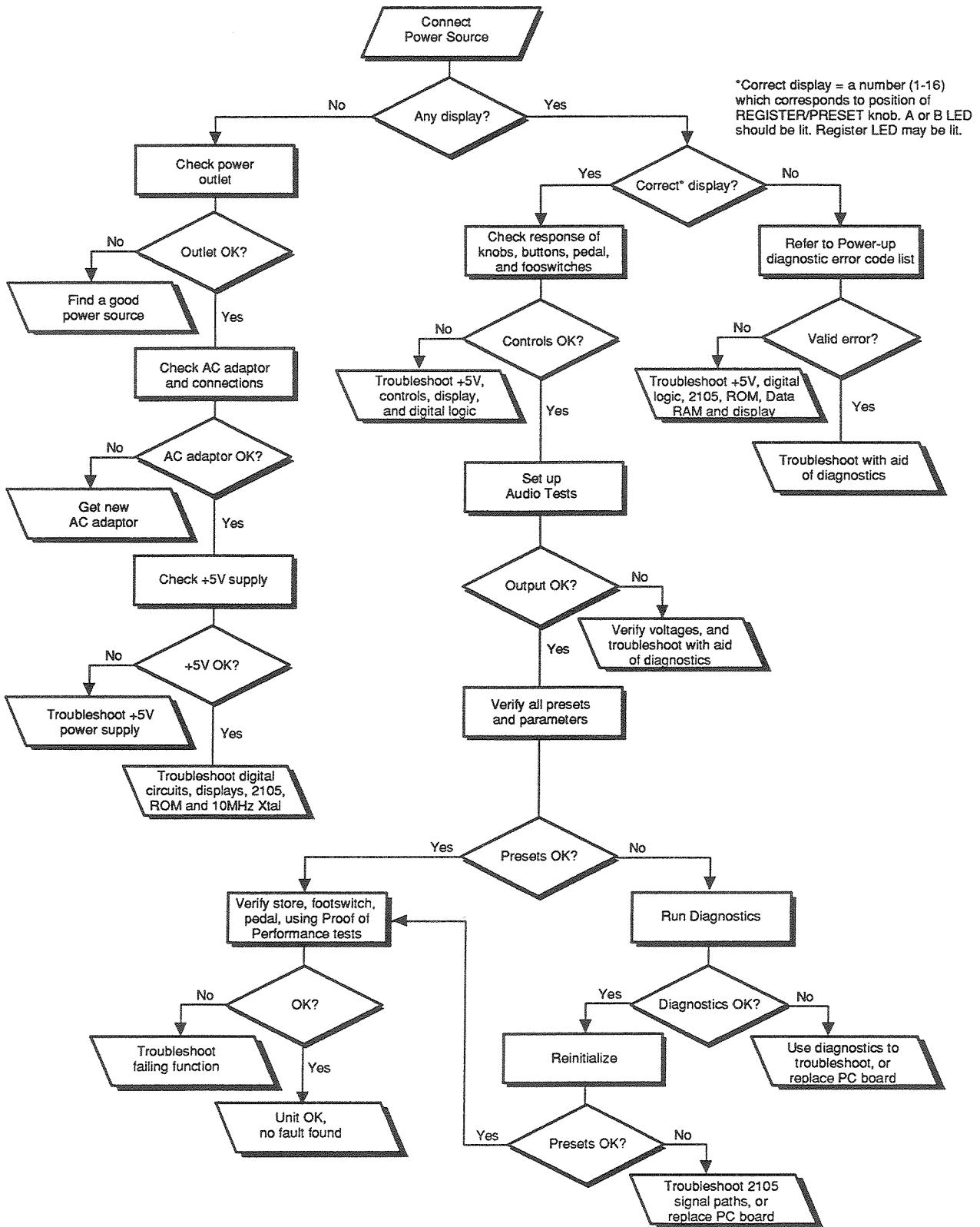

Analog I/O

Reference designators are given for the right channel; reference designators for the left channel are given in parentheses.

The heart of the analog section is U30, a Crystal Semiconductor CS4216 CODEC (COder/DECOder). This chip contains a stereo A/D and D/A, input amplifiers and output attenuators. To maximize performance, external input and output amplifiers. Because the CODEC runs off a single-ended 5V supply, the input and output amplifier sections were also designed to use a single supply.

Input jacks J11 and J10 are configured so that, if only one plug is inserted, the signal will be routed to left and right input amplifiers. C70 (C79) passes RFI to ground, and C74 (C80) blocks DC from the input signals. Stereo pot R86 attenuates the input signal. R90 (R91) provides current limiting if the R86 wiper is at the top. D16 (D17) and D18 (D19) protect the CMOS inputs of U34.

U34 is configured as a non-inverting amplifier with a gain of 21 (26.4 dB) at DC. $(R84+89)/R84=21$. C77 (C78) provides attenuation above approximately 60 KHz to help out the anti-aliasing filter R88-C58 (R93-C56). C71 (C72) and R83 (R94) provide an approximately 15-50 μ sec preemphasis curve. Adding preemphasis at the input allows deemphasis to be added at the output to help attenuate the high-frequency noise characteristic of single-bit DAC's.

The signal entering the CODEC must be centered around the REFBUF voltage, which is nominally 2.1V. This is accomplished by buffering REFBUF with U33, and replacing the ground references of the input amps with buffered REFBUF. The REFBUF signal itself is not capable of driving the low impedances needed at the VREF_R and VREF_L nets.

Capacitors C68 (C73) and C69 (C75) lower the noise and AC impedance on VREF_R (VREF_L). R82 (R85) keeps the capacitors from destabilizing the op-amps. R71 and C62 help to keep REFBUF clean before it is buffered. Two essentially identical versions of VREF reduce crosstalk between left and right inputs.

The CODEC produces a maximum output signal of 2.8 Vpp typical (2.13 dBu). The CODEC outputs pass through a low-pass filter consisting of R70 (R72) and C50 (C65). C49 (C64) and R66 (R73) add 15-50 μ sec deemphasis. C52 (C63) blocks the 2.1 V offset, and any DC offsets present on the signal. U32 is configured as an inverting amplifier with a low-frequency gain of +6 dB $(R79/(R70+R75)=2)$. The maximum output level is, therefore, 8.13 dBu.

The output amplifier's signal is centered at 3.5V (to account for asymmetry of the op-amp drivers) with R80 and R76, filtered with C55. An 8V supply is provided for the output amplifier stage.

R78 (R68) and R69 (R65) protect U32 from output short-circuits. D14 (D12), D15 (D13), and R69 (R65) protect U32 from ESD. C48 (C43) removes the 3.5V DC offset. C46 (C42) filters RFI. R64 (R59) discharges C48 (C43) to prevent popping.

The following table explains what happens when various plugs are inserted into the output jacks:

Left Jack	Right Jack	Left Tip/Ring	Right Tip
mono	mono	left	right
mono		left	
	mono		left+right
stereo		left/right	

Although the output amps can drive high-impedance ($>100\Omega$) headphones, they were not designed for low-impedance phones. For best results, use a headphone amp.

Note the lack of an output level pot. The CODEC handles output attenuation of 0dB to -46.5 dB, in 1.5 dB steps. Also note that there is no "dry" analog path. All analog signals go through the converters. The DSP software performs the functional equivalent of a wet/dry mixing pot.

The 8 MHz needed by the CODEC is provided by a ceramic resonator and a CMOS oscillator (U31). The CODEC has two available digital inputs (DI1 and DI2) and two digital outputs (DO1 and DO2). DO2 is fed back into DI2 to create a diagnostic loopback, and to detect synchronization errors. DO1 is used to drive the overload LED through U31.

Vortex processing is accomplished with an Analog Devices ADSP-2105 DSP chip running at 10 MHz. An on-board crystal oscillator generates the DSP master clock. The cycle time is 100 nsec for all instructions, except those which access external memory. The chip contains 1024 24-bit words of on-chip program RAM and 512 16-bit words of on-chip data RAM.

Processor

Because the 2105 needs to access the EPROM during run time, as well as during program boot, the EPROM is mapped into boot and program memory.

The 2105 16K address space is mapped as follows:

Data Memory Map

Address	Read	Write
0 wait states:		
1000		DRAM address write page 0
1001		DRAM address write page 1
1002		DRAM address write page 2
1003		DRAM address write page 3
1800		Display register
1801	status low	
1C01	status high	
1C00		A/B relay off
1C40		A/B relay on
1C80		EPROM_A12 low
1CC0		EPROM_A12 hi
1D00		EPROM_A14 low
1D40		EPROM_A14 hi
1D80		EEPDI low
1DC0		EEPDI hi
1E00		EEPCLK low
1E40		EEPCLK hi
1E80		ADCCS/ low
1EC0		ADCCS/ hi
1F00		EEPCS_A15 low
1F40		EEPCS_A15 hi
1F80		CODEC_RST/ low
1FC0		CODEC_RST/ hi
1 wait state		
3400	DRAM read/write	
3C00-3FFF	Internal memory and registers	

Program Memory Map

Address	Read	Write
0000-07FF	Internal memory	
2 wait states:		
0800-0FFF;	EPROM	
2000-2FFF;	EPROM	

Note that EPROM addresses 0000-07FF are available during cold or warm boot.

The most critical timing issue in the 2105 is write hold. The 2105 running at 10 MHz has a write hold time spec of only 15 nsec. Once the strobe is decoded, it leaves little time for the data hold of the latches. However, even though the data bus may be tri-stated as early as 15 nsec after the end of the write strobe, it is never reasserted until at least 50 nsec after the end of the write strobe. During that time, the data bus stays right where it is, not relaxing more than 0.5V or so with typical loads. Nonetheless, Vortex uses an AC part (U7) for strobe decoding.

Audio memory consists of four 64K x 4 DRAMs (U15, U18, U20, U21), which provide a total of two seconds of delay. The unit may optionally be configured with 256K x 4 DRAM's, with the addition of U10.

The DRAM state diagram is shown below. To access the DRAM, the 2105 first writes the address to U12 and U13. RASEN/, created by U11 at the lower left, is normally low, so MA0-8 contain the row address shortly after the end of the write strobe. This same strobe (ADDR_WR/) also sets an S-R flip-flop made from U11, bringing pin 3 high.

At the beginning of cycle (2), CLKOUT clocks U9 pin 9 high. One cycle later (3), U14 pin 6 (RAS/) goes low, strobing the row address into the DRAM.

The state machine will remain in this state until the 2105 executes a DRAM data read or write (activating DRAM_RD/ or DRAM_WR/ strobes). The code is written so that the DRAM address write and the DRAM read/write instructions are separated by at least one instruction (state 2 in the timing diagram), but more than one instruction may be inserted without altering the state machine. Because of an internally generated wait state, the DRAM read/write strobes last for two cycles. If either strobe is asserted, U11 pin 11 goes high, deasserting RASEN/. A propagation delay later, U11 pin 8 (CASEN/) goes low, enabling the upper addresses onto MA0-8. Because of the tight timing from CASEN/ asserted to CAS/ asserted, U11 is an AC part.

At the beginning of the next cycle (4), CLKOUT clocks U14 and CAS/ goes low, strobing the column addresses into the DRAMs. Because of the tight timing from CLKOUT to data valid during a read, U14 must be an AC part. CAS/ also clears the S-R flip-flop, so that the next CLKOUT deasserts RAS/ and CAS/.

Refresh circuitry is unnecessary as the software guarantees that every row is accessed every 2 msec.

Resistors R26-R30, R95-R100 act as series terminators for the high-frequency signals created by the AC parts.

As mentioned above, the EPROM occupies a total of 8K of address space (0000-0FFF, 2000-2FFF), so three latched signals (EPROM_A12, EPROM_A14, and EEPCS_A15) are used to expand the address space to 64K. EEPCS does double duty as the EPROM_A15 line and the EEPROM chip select. All three lines must be low on power-up in order to select the correct code to boot into the 2105's program space. The pullup on A12 (R24) keeps the EPROM disabled when the address bus is tri-stated.

The two digits of the display are time-multiplexed. Approximately every 6 msec, one digit is turned off and the other is turned on. To drive the low (right-most) digit, the 2105 writes a 0 to U23 pin 5, and 1 to pin 2, turning on Q2 and turning off Q3. Q2's collector sources current into the common anode of the low digit on the display board. At the same time, the 2105 writes 0's to the appropriate segment outputs of U24.

I/O

As an HC374 part can directly drive a non-multiplexed LED, the status LEDs are driven directly with U23. In order to balance the current in the Vcc and ground leads of U23, LED2 and LED4 are configured such that U20 drives them high. LED1 and A/B_DISP are driven low.

Addressable latch U2 handles all other control signals. After reset, all of its outputs will be low. Individual control signals are changed by writing to the addresses listed in the Data Memory Map.

RY1 provides an external switch closure for control signals to combo amps. It can switch up to 100 V at up to 100 mA. It is not intended for switching audio. When Vortex is in "A" mode (the "A" LED is on), U2 pin 4 is low and RY1 is off. This shorts J1's sleeve to ring. C84 filters RFI. When Vortex goes into "B" mode, U2 pin 4 goes high, which turns on Q1, which turns on RY1. This opens J1's sleeve-ring connection, and shorts sleeve to tip.

Input status is read into multiplexers U29, U3, and U4. A10 selects which half of the multiplexers to read, creating status_lo and status_hi mentioned in the data memory map.

The encoders are 16-position gray-scale encoders.

The pedal circuit uses a TLC549 8-bit A/D converter. The A/D shares the EEPROM's serial clock and data lines.

Most potentiometer-based pedals tie the ends of the pot to ring and sleeve and the wiper to tip. For these pedals, Vortex supplies 5V through R17 to ring. R17 is large enough to keep 5V from shorting out if a mono plug is inserted into the jack, but small enough to allow a pot of 50 K or less to swing the full range. R14, D2, and D3 protect the A/D. R15 and C9 low-pass filter the pedal voltage.

Control voltage sources may also be sent into the pedal input, although the range is 0-5V rather than the standard 0-10V. Voltages over 5V will be tied to 5V through D3, although the control voltage will be isolated by R14. A stereo plug should be used for this application. A mono plug will short ring to sleeve, heating the unit unnecessarily.

Register information is stored in U1, a 93C66 4 K-bit EEPROM. The EEPROM can store a total of 32 register settings, with 128 bits per register. Note that each address location of the EEPROM can only be written to 100,000 times. Because the EEPROM is only written to when the STORE or CLEAR buttons are pressed, this limitation is not a concern during normal operation.

Power Supply The power supply consists of a full-wave rectifier feeding three linear voltage regulators. U25 and U27 are standard 5V linear regulators in TO-220 packages. Separate regulators are used for analog and digital 5V to control noise. U26 is an 8-volt low-drop-out linear regulator used to power the analog output stage.

U28 generates a reset pulse on power-up, and in response to a low-voltage condition. Whenever the unregulated voltage (VUNREG) is high enough to keep U26 in regulation, it will exceed U26's output voltage (8V) by more than the dropout voltage (0.1V typ at 25 mA). However, if the unregulated voltage falls below U26's output plus one diode drop, pin 3 of U28 will drop below pin 2, and pin 1 will go low, discharging C40. This brings pin 5 below pin 6, which brings RESET/low. R49-C40 provide a minimum reset on time of roughly 400 msec, which gives the 2105's oscillator sufficient time to stabilize. C41 filters the ripple voltage on VUNREG.

Tantalum capacitors C28, C37, and C57 (sheet 1) filter the regulated voltages and stabilize the regulators.

Running CODEC in master sub-mode of mode 3 with square SSSYNC

**CODEC/DSP
Serial I/O Timing**

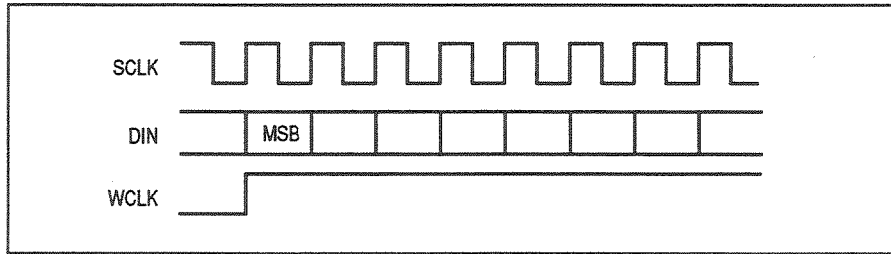

This corresponds to the 2105's alternate framing mode.

DRAM State Machine

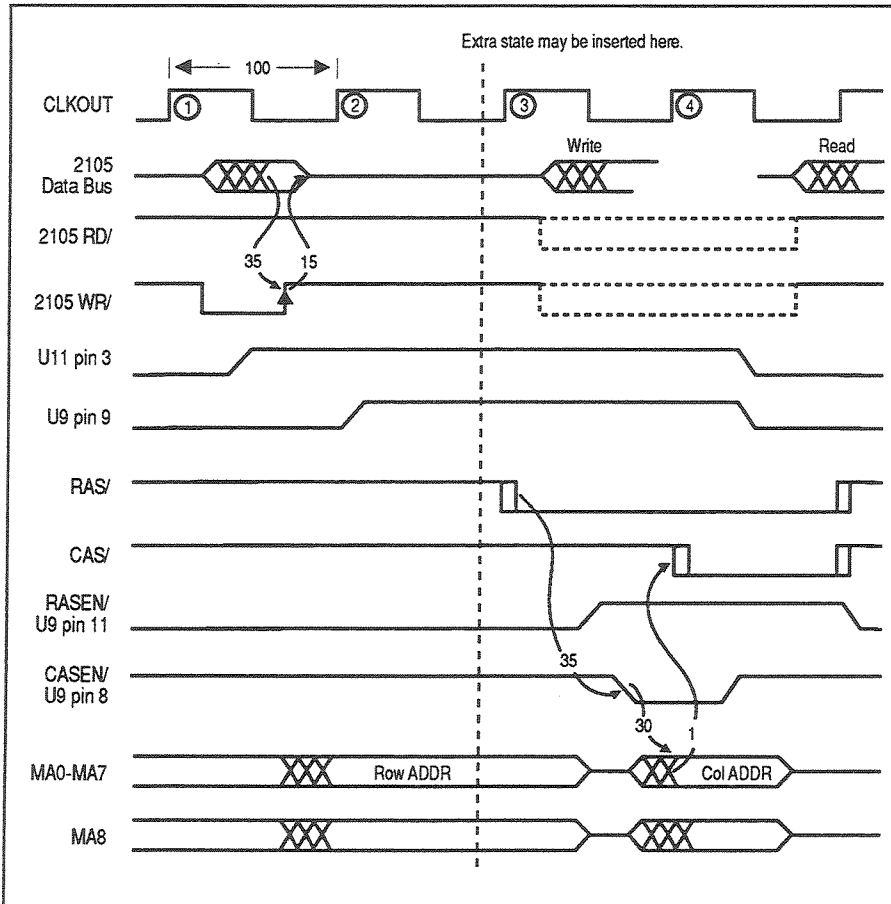

5 Parts List

MAIN BOARD

PART NO.	DESCRIPTION	QTY	REFERENCE
POTENTIOMETERS			
200-09545	POT,RTY,PC,50KAX2,6MMFL,16,17L	1	R86
RESISTORS			
202-00512	RES,CF,5%,1/4W,75 OHM	11	R26-30,95-100
202-00515	RES,CF,5%,1/4W,150 OHM	3	R17,88,93
202-00520	RES,CF,5%,1/4W,270 OHM	9	R31-35,40,43-45
202-00524	RES,CF,5%,1/4W,470 OHM	6	R19,41,42,74,90,91
202-00525	RES,CF,5%,1/4W,510 OHM	2	R68,78
202-00528	RES,CF,5%,1/4W,820 OHM	2	R70,72
202-00529	RES,CF,5%,1/4W,1K OHM	3	R1,37,39
202-00533	RES,CF,5%,1/4W,2K OHM	2	R36,38
202-00542	RES,CF,5%,1/4W,4.7K OHM	6	R6,7,11,12,14,15
202-00563	RES,CF,5%,1/4W,47K OHM	27	R2-5,8-10,13,16,18,20-25,47,48,52-54 R57-59,62-64
202-00579	RES,CF,5%,1/4W,470K OHM	1	R56
202-00580	RES,CF,5%,1/4W,1M OHM	1	R67
202-01228	RES,CF,5%,1/4W,620 OHM	2	R82,85
202-08190	RES,CF,5%,1/4W,110 OHM	2	R65,69
203-00453	RES,MF,1%,1/4W,316 OHM	2	R66,73
203-00469	RES,MF,1%,1/4W,7.87K OHM	2	R89,92
203-00471	RES,MF,1%,1/4W,10.0K OHM	7	R50,51,55,60,61,79,81
203-00488	RES,MF,1%,1/4W,37.4K OHM	1	R76
203-01491	RES,MF,1%,1/4W,4.22K OHM	3	R71,75,77
203-01671	RES,MF,1%,1/4W,47.5K OHM	3	R46,49,80
203-02399	RES,MF,1%,1/4W,174 OHM	2	R83,94
203-09961	RES,MF,1%,1/4W,392 OHM	2	R84,87
CAPACITORS			
240-00608	CAP,ELEC,2.2uF,50V,RAD	2	C41,55
240-00609	CAP,ELEC,10uF,16V,RAD	2	C40,83
240-00614	CAP,ELEC,47uF,16V,RAD	2	C69,75
240-06096	CAP,ELEC,10uF,25V,RAD,NON-POL	6	C43,48,52,63,74,80
240-09541	CAP,ELEC,3300uF,16V,RAD	1	C39
241-00654	CAP,TANT,22uF,16V,RAD	5	C28,37,45,57,59
244-00662	CAP,MYL,.1uF,5%,RAD	2	C71,72
244-06176	CAP,MYL,.047uF,5%,RAD	2	C49,64
244-06883	CAP,MYL,.01uF,5%,RAD	4	C50,56,58,65
245-00590	CAP,CER,150pF,500V,10%,Y5P	4	C42,46,70,79
245-00593	CAP,CER,560pF,50V,10%,Z5F	2	C60,61
245-03609	CAP,CER,.1uF,50V,Z5U,AX	36	C1-3,8-11,14,17-23,25-27,29-36,44,47, C53,54,62,66-68,73,81
245-03610	CAP,CER,.01uF,100V,Z5U,AX	4	C15,16,24,38
245-03869	CAP,CER,100pF,100V,COG,10%,AX	6	C4-7,77,78
245-07344	CAP,CER,470pF,100V,COG,10%,AX	1	C84
245-07544	CAP,CER,18pF,100V,COG,10%,AX	2	C12,13
FERRITE BEADS			
270-00779	FERRITE,BEAD	4	FB1-4
DIODES			
300-01029	DIODE,1N914 AND 4148	11	D2,3,11-19
300-01030	DIODE,1N4004 AND 4005	8	D1,4-10

PART NO.	DESCRIPTION	QTY	REFERENCE
TRANSISTORS			
310-01646	TRANSISTOR,2N4403	2	Q2,3
310-01647	TRANSISTOR,2N4401	1	Q1
INTEGRATED CIRCUITS			
330-01293	IC,DIGITAL,74LS374	1	U24
330-03583	IC,DIGITAL,74HC374	1	U23
330-04509	IC,DIGITAL,74HC74	1	U9
330-07066	IC,DIGITAL,74AC74	1	U14
330-07067	IC,DIGITAL,74HCU04	1	U31
330-07536	IC,DIGITAL,74HC574	2	U12,13
330-07596	IC,DIGITAL,74AC00	1	U11
330-07708	IC,DIGITAL,74AC139	1	U7
330-09082	IC,DIGITAL,74HC259	1	U2
330-09951	IC,DIGITAL,74HC257	3	U3,4,29
340-00742	IC,LINEAR,7805 (LM340T-5)	2	U25,27
340-05945	IC,LINEAR,LM393	1	U28
340-09952	IC,LINEAR,LM2930T-8.0,TO-220	1	U26
340-09962	IC,LINEAR,LM358,DUAL OP AMP	1	U33
340-09963	IC,LINEAR,MC34072,DUAL OP AMP	1	U32
340-09964	IC,LINEAR,TLC2272,DUAL OP AMP	1	U34
350-07490	IC,DRAM,64KX4,100NS	4	U15,18,20,21
350-09950	IC,ROM,27512,VORTEX,V1.20	1	U5
350-09953	IC,EEPROM,93C66,4K BIT,SER	1	U1
355-09954	ADC,TLC549,8 BIT,SERIAL	1	U6
355-09955	ADC/DAC,CS4216,CODEC,STEREO	1	U30
365-09224	IC,uPROC,ADSP-2105,CPU	1	U8
CRYSTALS			
390-09956	CRYSTAL,10.00MHz	1	Y1
390-09957	RESONATOR,CER,8.00MHz	1	Y2
RELAYS			
410-03584	RELAY,2P2T,LOW LEVEL,DIP,12V	1	RY1
DISPLAYS/INDICATORS			
430-07325	LED,RED,T1,LITON	2	LED1,3
430-07326	LED,GRN,T1,LITON	2	LED2,4
SWITCHES			
452-09555	SW,RTY,BCD,16POS,17.5MM	3	S1,3,6
453-09550	SW,PBM,1P1T,6MM SQ,PCRA,130GF	3	S2,4,7
453-09960	SW,PBM,1P1TX2,6MM SQ,PCRA,VERT	1	S5
CONNECTORS			
490-02356	CONN,JUMPER,.1X025,2FCG	2	W1,2
510-03961	CONN,POST,100X025,HDR,2MCG	2	W1,2
510-06042	CONN,DC POWER,PC,DJ005,2.5MM	1	J6
510-09553	1/4"PHONE JACK,PCRA,3C,SW,OF	5	J1-4,8
510-09554	1/4"PHONE JACK,PCRA,2C,SW,OF	3	J9-11
SOCKETS			
520-01458	IC SCKT,28 PIN,PC,LO-PRO	1	U5
520-09077	IC SCKT,PLCC,68 PIN	1	U8
520-09965	IC SCKT,PLCC,44 PIN	1	U30
HEAT SINKS			
600-09966	CLIP,HEATSINK,TO-220	3	U25-27

PART NO.	DESCRIPTION	QTY	REFERENCE
HARDWARE			
620-09648	LUG,SOLDER,.5IDX.72OD/FL.25TAB	8	J1-4,8-11
650-04772	POPRVT,1/8X3/16,REG PROT HD,AL	1	HEATSINK
704-09941	HEATSINK,TO-220,SAM	1	U25-27

DISPLAY BOARD

PART NO.	DESCRIPTION	QTY	REFERENCE
DISPLAY BOARD			
DISPLAYS/INDICATORS			
430-07325	LED,RED,T1,LITON	3	D1-3
430-09958	LED,DSPLY,7-SEG,RED,2DIG,.56	1	DISP1
CONNECTORS			
510-09551	CONN,POST,100X025,HDR,3MC,RA	1	J2
510-09959	CONN,POST,100X025,HDR,4MC,RA	1	J1

MECHANICAL PARTS

PART NO.	DESCRIPTION	QTY	REFERENCE
MECHANICAL/MISC PARTS			
KNOBS/BUTTONS			
550-09570	KNOB,17.5MM,6MM/FL,BLK/WHTLN	4	
550-09610	BUTTON,.16X.61,BLK	5	S2,4,5,7
HARDWARE			
641-10243	SCRW,TAP,SW,4-40X3/8,TH,T9,LOK	7	(2) COVER; (1) GND; (4) ENDCAPS
644-09567	WSHR,INT,STAR,7MM,ZN	3	ENCODERS
MECHANICALS			
700-09930	COVER,SAM	1	
702-09564	PANEL,SIDE,CASTING,SAM,BLK	2	
702-09933	PANEL,FRONT,SAM	1	
703-09537	LENS,DISPLAY,SAM	1	
720-09539	TAPE,FOAM,.032X.25X7	4	
ACCESSORIES			
470-09650	XFORMER,PLUG-IN,120V,9VAC,10mm	1	120V ONLY
740-09368	LABEL,ACCESSORY,FOOTSWITCH	1	
740-09651	LABEL,CE MARK	1	REAR PANEL
750-09277	FOOTSWITCH,DBL,MOM,STEREO CABLE	1	

6 Schematics

Foot Controller Fixture

Lexicon uses a specially-designed test fixture for testing foot controllers. Following is a description of this fixture as well as a parts list, in the event you want to build a similar fixture for your own use. A reference drawing is included with the other schematics and assembly drawings.

The Foot Controller Test Fixture provides an automatic 0 to +5V sweep for testing Lexicon products equipped with foot controller inputs. The fixture minimizes operator error when testing the controller inputs while still providing a thorough test.

The fixture provides a triangle waveform to the Controller Inputs with a low frequency sweep rate of approximately .5Hz. When monitored by the Diagnostic Test: Footpedal (2)* of Vortex diagnostics, the display will sweep from 00 to FF in hex with a short pause at each extreme.

The fixture also contains a circuit for detecting the presence of +5V at the ring of the controller input being tested. If the voltage at the ring is below 4V, the fixture output is muted and its LED will light.

Theory Of Operation: (See schematic 060-90033.)

The fixture is powered by an external "ELPAK WM063" power supply module which provides $\pm 12V$ at 180MA each and +5V at 380MA. Power is fed into the fixture via a 5-pin DIN connector. The first half of U1 (a 4558 op amp) is configured as a low-frequency oscillator with R4 setting the rate. The output of U1 is routed through a 1k Ω resistor to SW1 which normally connects to the output of the fixture. When SW1 is pressed, the output of the fixture is connected to R14 (200K) which forms a resistive ladder with the internal pullup resistor in Vortex.

When the fixture is connected to Vortex, +5V will be fed from the ring of the controller input being tested to the ring on connector J1 of the fixture. This voltage is sent to the base of transistor Q3 through resistor R10. R10 combined with R11 enables the voltage and/or impedance of the +5V line to turn the transistor on or off. If voltage drops below 4V, Q3 turns on. This biases both Q1 and Q2 on, lighting the LED and muting the fixture output. This verifies that +5V is present at the ring of the controller input and also checks the value of the resistor feeding the ring of the controller input.

*Footpedal (2)

This test only verifies the Footpedal Controller Input to the ADC and must be run with the Foot Controller Test Fixture or comparable circuitry. Testing the Controller Input and the ADC chip with a footpedal can be accomplished using the ADC Monitor test. The ADC test checks the Footpedal Controller Input by using the Foot Controller Test Fixture which contains an LFO to sweep the Controller input from its minimum value (0VDC) to its maximum voltage (+5VDC), then back to its minimum. The ADC Test analyzes the data generated by the ADC chip during the sweep and confirms that the chip is accurately reporting the voltage to the processor.

When the test is running, the display shows the ADC reading the LFO. When the sweep has been completed successfully, the test displays "PA" for pass. This test can also serve as a footpedal monitor test displaying the current position of a footpedal for troubleshooting.

Foot Controller Fixture Parts List

PART NO.	DESCRIPTION	QTY	REFERENCE
LINEAR IC			
340-00740	IC,LINEAR,4558	2	U1
IC SOCKETS			
520-00941	IC SCKT,8 PIN,PC,LO-PRO	2	U1
RESISTORS			
202-00529	RES,CF,5%,1/4W,1K OHM	1	R6
202-00538	RES,CF,5%,1/4W,3.3K OHM	1	R13
202-00555	RES,CF,5%,1/4W,20K OHM	1	R9
202-00564	RES,CF,5%,1/4W,51K OHM	2	R11
202-00570	RES,CF,5%,1/4W,100K OHM	2	R4,10,12
202-00576	RES,CF,5%,1/4W,200K OHM	2	R14
202-00579	RES,CF,5%,1/4W,470K OHM	3	R7,8
203-00460	RES,MF,1%,1/8W,2.15K OHM	1	R2,5
203-00465	RES,MF,1%,1/8W,6.49K OHM	3	R3
203-00474	RES,MF,1%,1/8W,11.0K OHM	1	R1
CAPACITORS			
240-00609	CAP,ELEC,10uF,16V,RAD	4	C2,3,4

