

ECOs INCLUDED ON THIS SCHEMATIC/PCB REVISION		
ECO NO:	DATE:	DESCRIPTION:
0309403	04.10.03	Part changes to prevent possible feedback at high gain. Released as rev.E1
023409	12/20/02	RELEASED REV.E SCH & PCB (fixed missing via in rev.D)

D

C

B

A

D

C

B

A

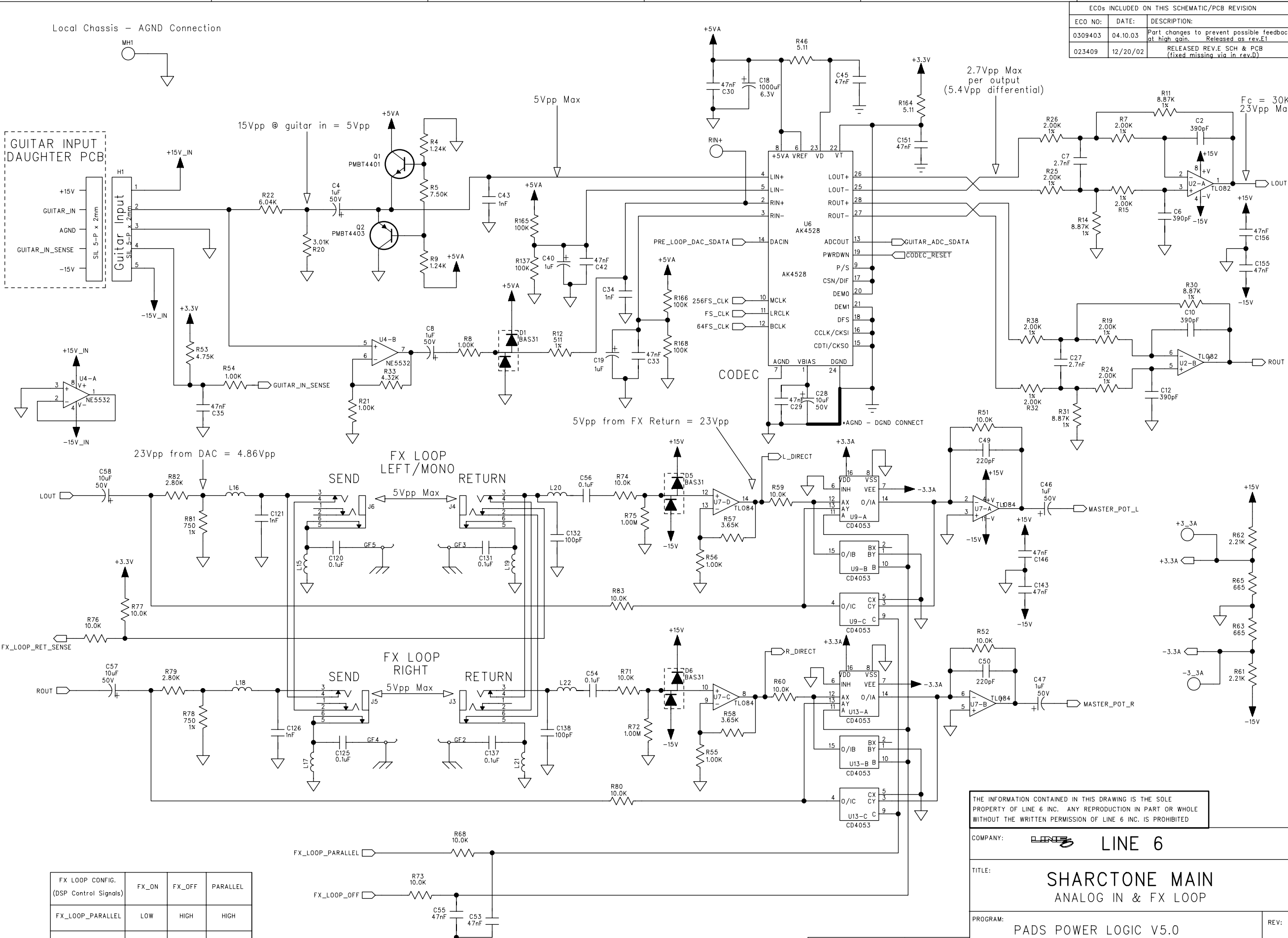

FX LOOP CONFIG. (DSP Control Signals)	FX_ON	FX_OFF	PARALLEL
FX_LOOP_PARALLEL	LOW	HIGH	HIGH
FX_LOOP_OFF	LOW	HIGH	LOW

THE INFORMATION CONTAINED IN THIS DRAWING IS THE SOLE PROPERTY OF LINE 6 INC. ANY REPRODUCTION IN PART OR WHOLE WITHOUT THE WRITTEN PERMISSION OF LINE 6 INC. IS PROHIBITED

COMPANY: LINE 6		REV: E1
TITLE: SHARCTONE MAIN ANALOG IN & FX LOOP		
PROGRAM: PADS POWER LOGIC V5.0	FILENAME: /Sharctone Product Family/DUET 212 Combo/Electrical/Schematic/Main/REV E/SHARCTONE MAIN REV E1.sch	SCALE: 1:1
DRAWN: DBLACKMORE	DATED: 1/22/02	SIZE: C
CHECKED: Name (F.Last)	DATED: 00/00/01	PART NUMBER: 35-00-0121
SHEET: 1 OF 7		

ECOs INCLUDED ON THIS SCHEMATIC/PCB REVISION		
ECO NO:	DATE:	DESCRIPTION:

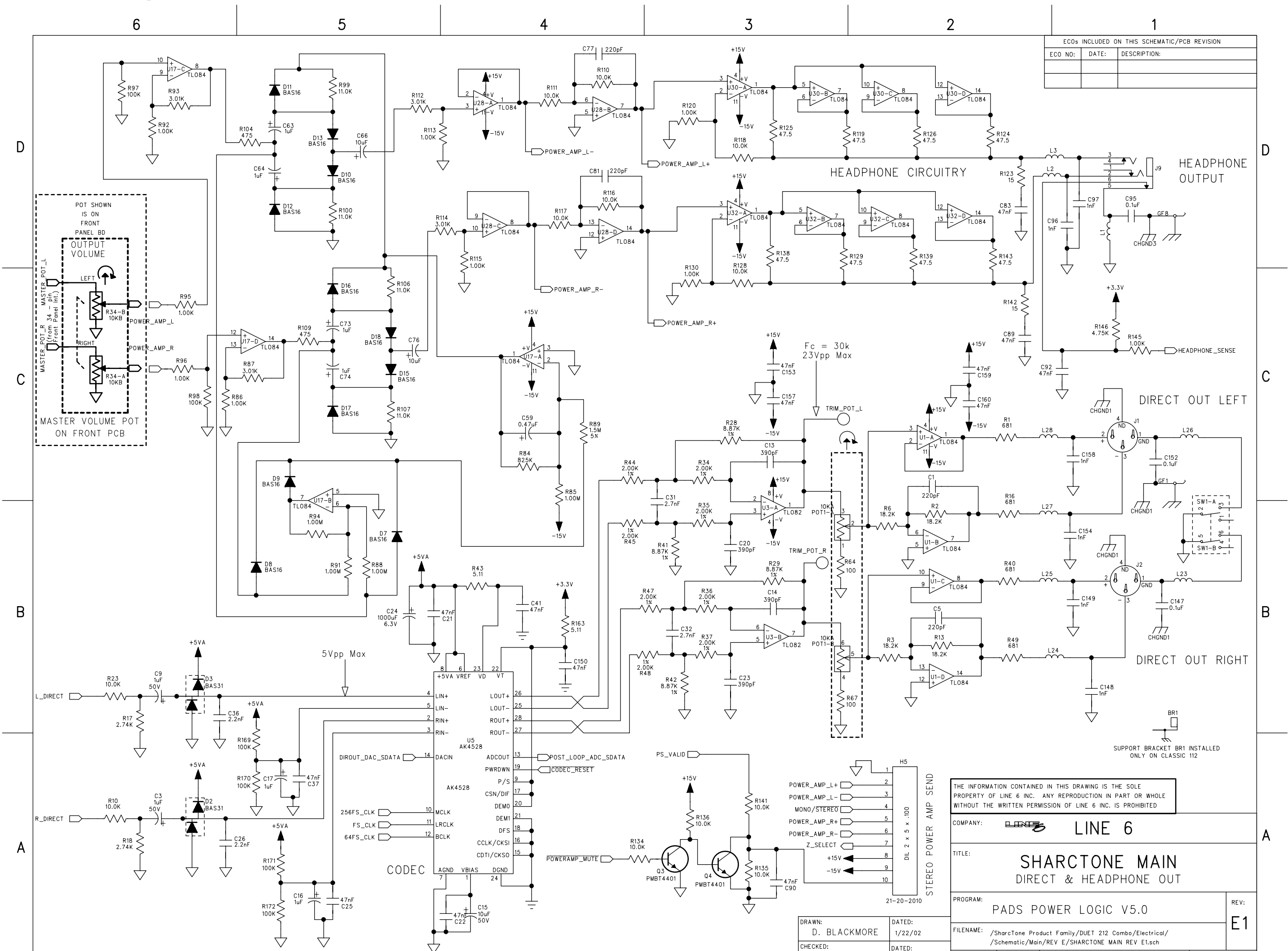

THE INFORMATION CONTAINED IN THIS DRAWING IS THE SOLE PROPERTY OF LINE 6 INC. ANY REPRODUCTION IN PART OR WHOLE WITHOUT THE WRITTEN PERMISSION OF LINE 6 INC. IS PROHIBITED

COMPANY:	LINE 6
TITLE:	SHARCTONE MAIN DIRECT & HEADPHONE OUT
PROGRAM:	PADS POWER LOGIC V5.0
FILENAME:	/Sharctone Product Family/DUET 212 Combo/Electrical/ /Schematic/Main/REV E/SHARCTONE MAIN REV E1.sch
SCALE: 1:1	SIZE: C
PART NUMBER: 35-00-0121	SHEET: 2 OF 7

DRAWN:	D. BLACKMORE	DATED:	1/22/02
CHECKED:	Name (F.Last)	DATED:	00/00/01

REV: E1

POWER ENTRY

FROM POWER SUPPLY PCB

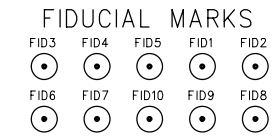
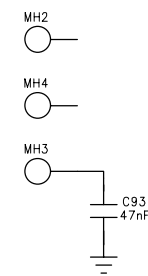
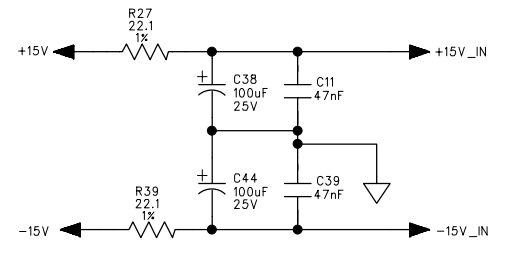
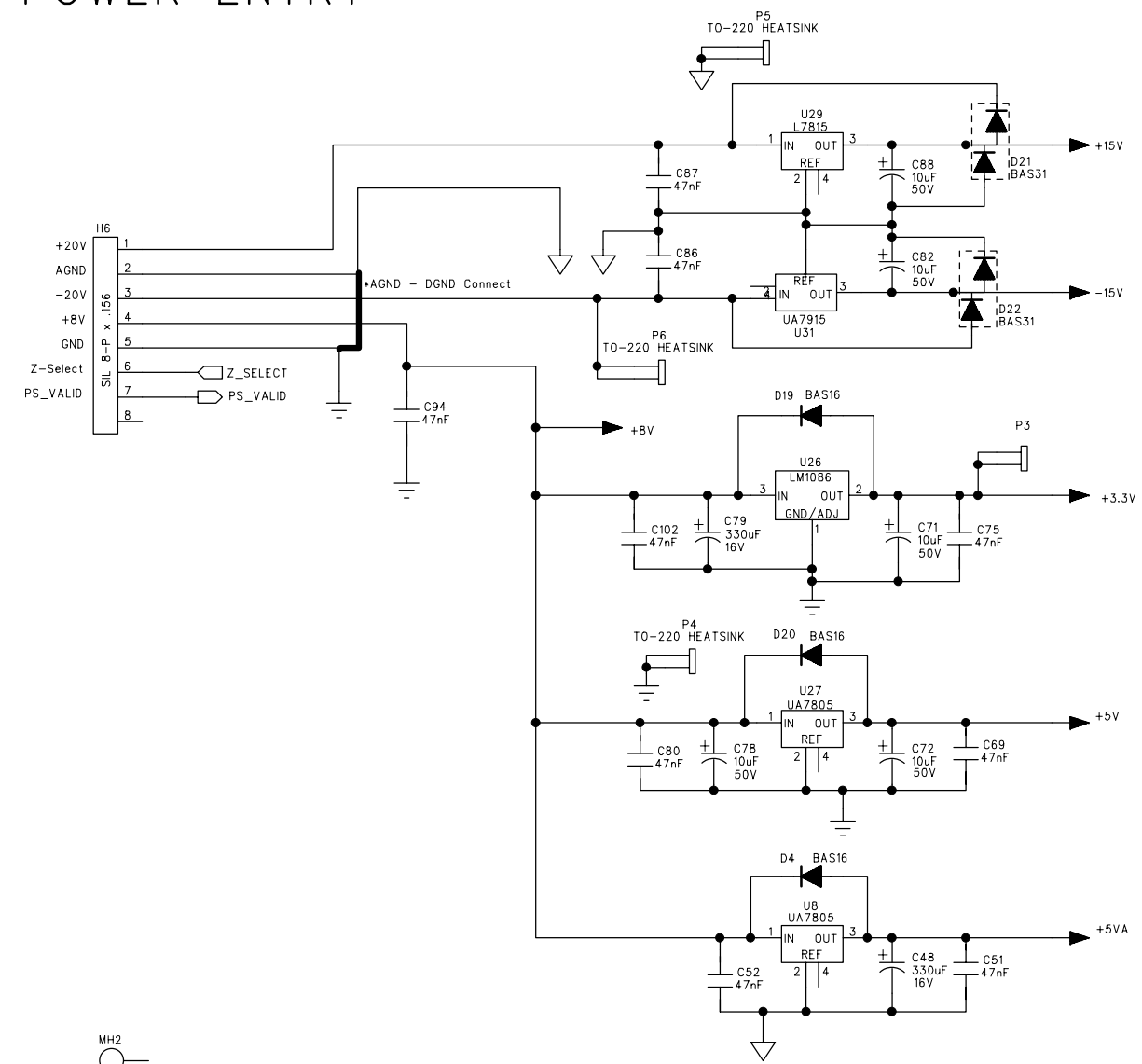

ECOs INCLUDED ON THIS SCHEMATIC/PCB REVISION		
ECO NO:	DATE:	DESCRIPTION:

THE INFORMATION CONTAINED IN THIS DRAWING IS THE SOLE PROPERTY OF LINE 6 INC. ANY REPRODUCTION IN PART OR WHOLE WITHOUT THE WRITTEN PERMISSION OF LINE 6 INC. IS PROHIBITED

COMPANY: LINE 6

TITLE: SHARCTONE MAIN POWER

PROGRAM: PADS POWER LOGIC V5.0

REV: E1

DRAWN: D. BLACKMORE

CHECKED: Name (F.Last)

DATED: 1/22/02

DATED: 00/00/01

FILENAME: /Sharctone Product Family/DUET 212 Combo/Electrical/Schematic/Main/REV E/SHARCTONE MAIN REV E1.sch

SCALE: 1:1 SIZE: C PART NUMBER: 35-00-0121 SHEET: 3 OF 7

ECOs INCLUDED ON THIS SCHEMATIC/PCB REVISION		
ECO NO:	DATE:	DESCRIPTION:

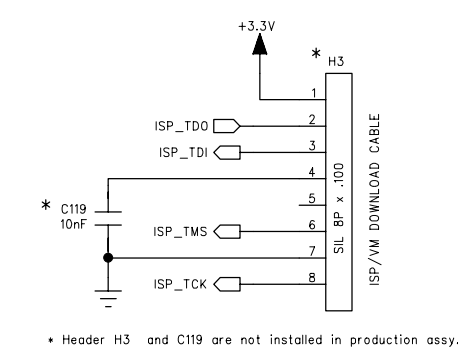
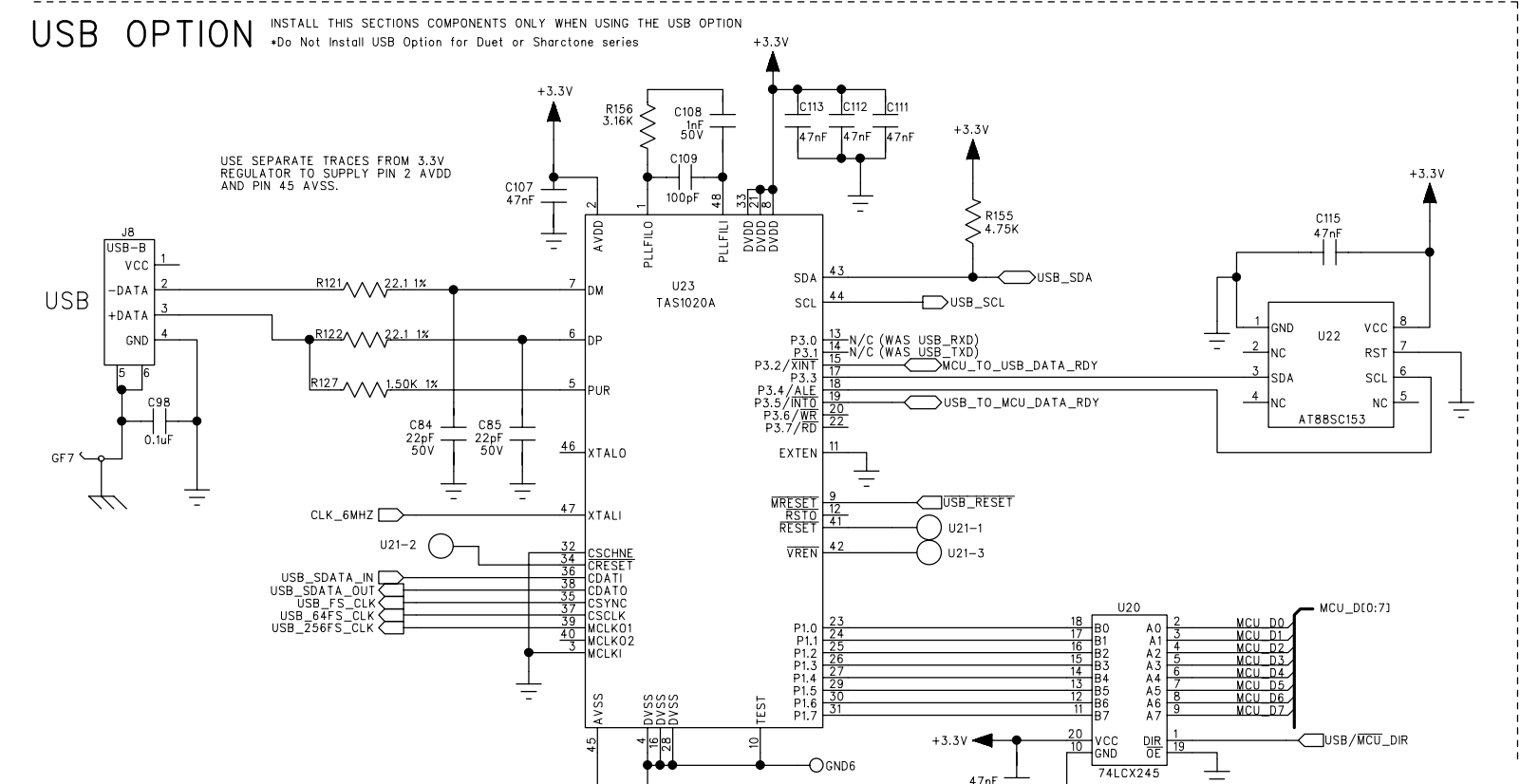
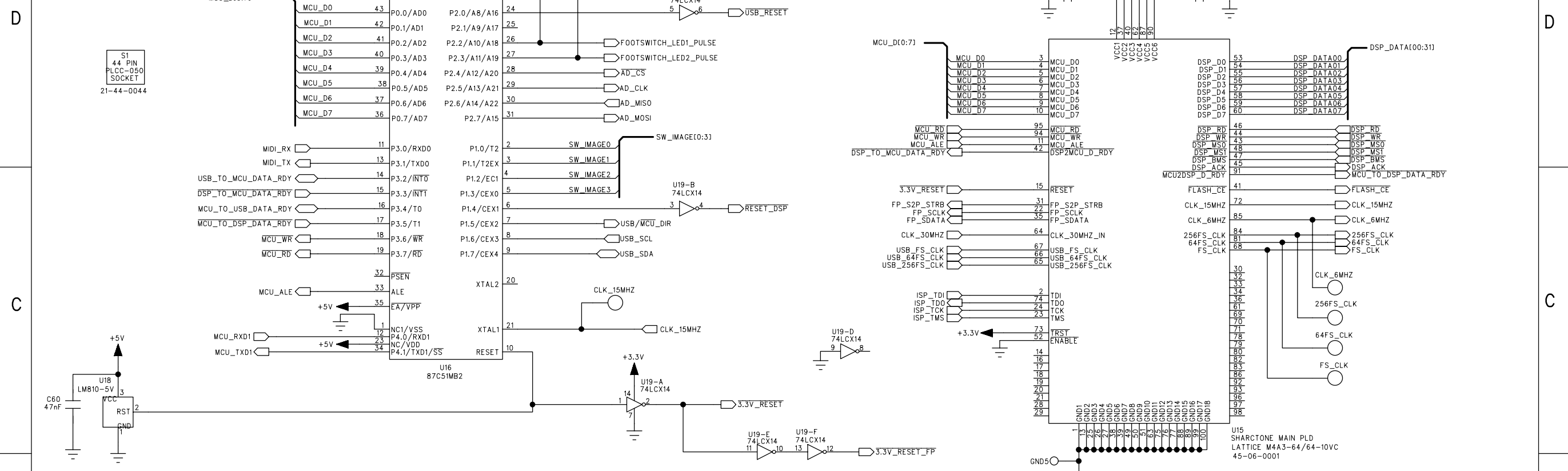

THE INFORMATION CONTAINED IN THIS DRAWING IS THE SOLE PROPERTY OF LINE 6 INC. ANY REPRODUCTION IN PART OR WHOLE WITHOUT THE WRITTEN PERMISSION OF LINE 6 INC. IS PROHIBITED

COMPANY:	LINE 6
TITLE:	SHARCTONE MAIN DIGITAL
PROGRAM:	PADS POWER LOGIC V5.0
FILENAME:	/Sharctone Product Family/DUET 212 Comba/Electrical/ /Schematic/Main/REV E/SHARCTONE MAIN REV E1.sch
SCALE: 1:1	SIZE: C
PART NUMBER: 35-00-0121	SHEET: 4 OF 7

DRAWN:	D. MOLNAR	DATED:	3/29/2002
CHECKED:	Name (F.Last)	DATED:	00/00/01

REV: E1

ECOs INCLUDED ON THIS SCHEMATIC/PCB REVISION		
ECO NO:	DATE:	DESCRIPTION:

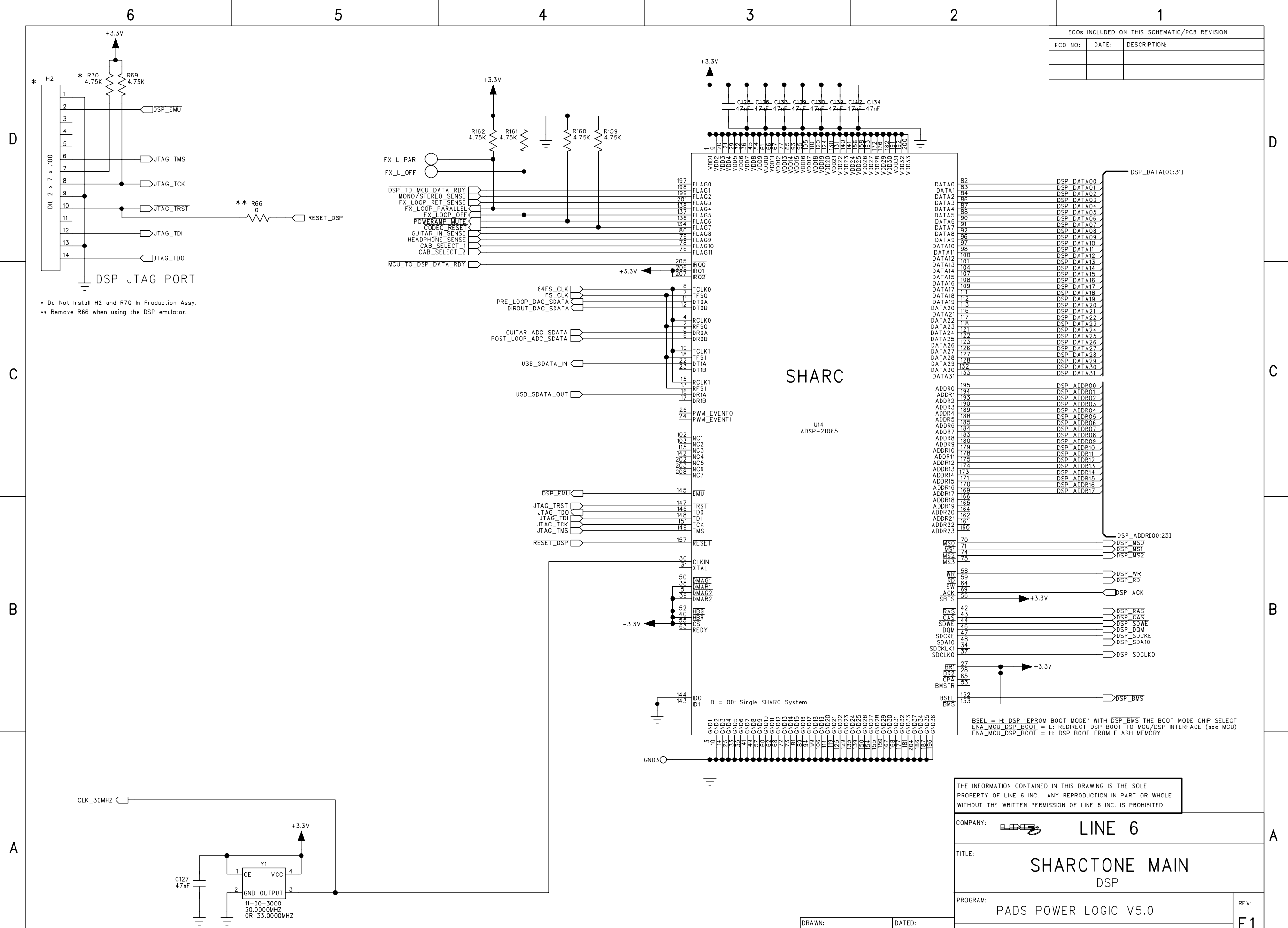

* Do Not Install H2 and R70 In Production Assy.
 ** Remove R66 when using the DSP emulator.

THE INFORMATION CONTAINED IN THIS DRAWING IS THE SOLE PROPERTY OF LINE 6 INC. ANY REPRODUCTION IN PART OR WHOLE WITHOUT THE WRITTEN PERMISSION OF LINE 6 INC. IS PROHIBITED

COMPANY: LINE 6	
TITLE: SHARCTONE MAIN DSP	
PROGRAM: PADS POWER LOGIC V5.0	REV: E1
FILENAME: /Sharctone Product Family/DUET 212 Combo/Electrical/Schematic/Main/REV E/SHARCTONE MAIN REV E1.sch	
SCALE: 1:1	SHEET: 5 OF 7

DRAWN: D. MOLNAR	DATED: 3/29/2002
CHECKED: Name (F.Last)	DATED: 00/00/01

A

A

C

C

D

D

DSP MEMORY

ECOs INCLUDED ON THIS SCHEMATIC/PCB REVISION		
ECO NO:	DATE:	DESCRIPTION:

SDRAM LOWER 1M X 16

SDRAM UPPER 1M X 16

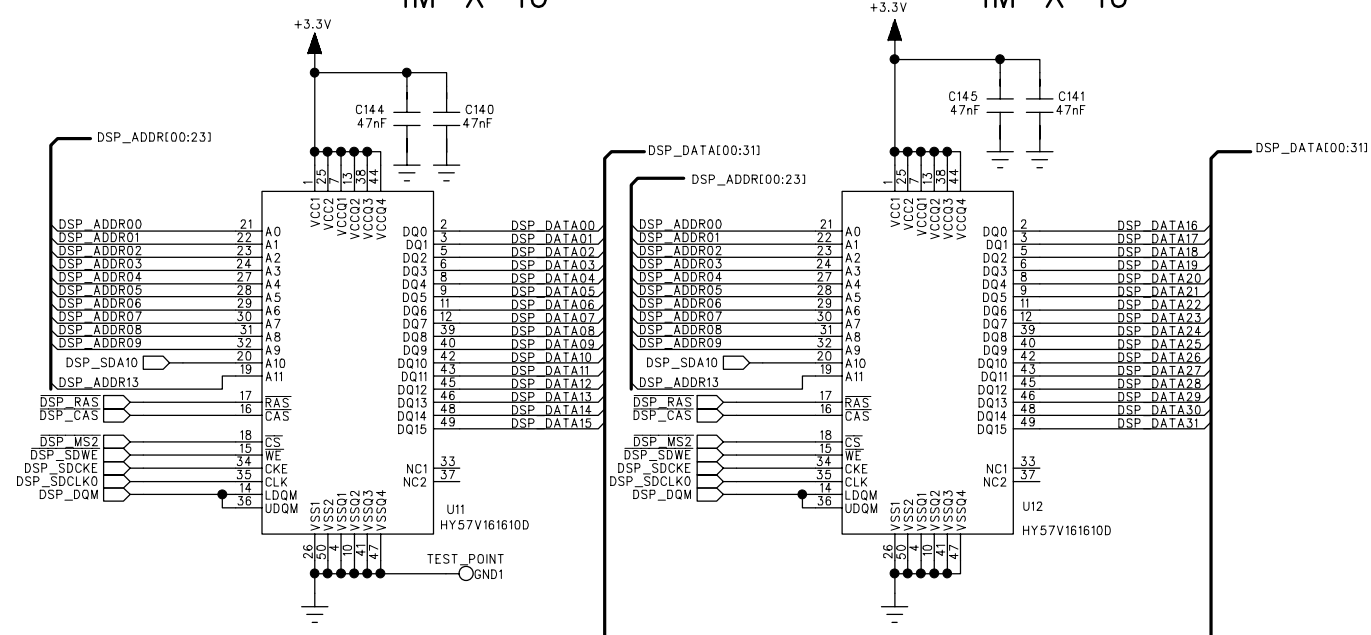

SDRAM LOWER 4M X 16

SDRAM UPPER 4M X 16

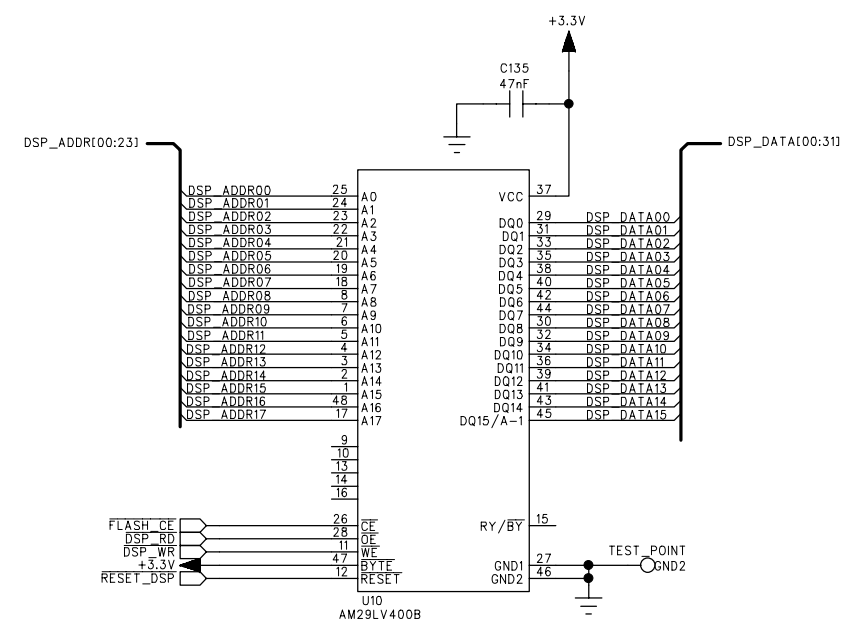
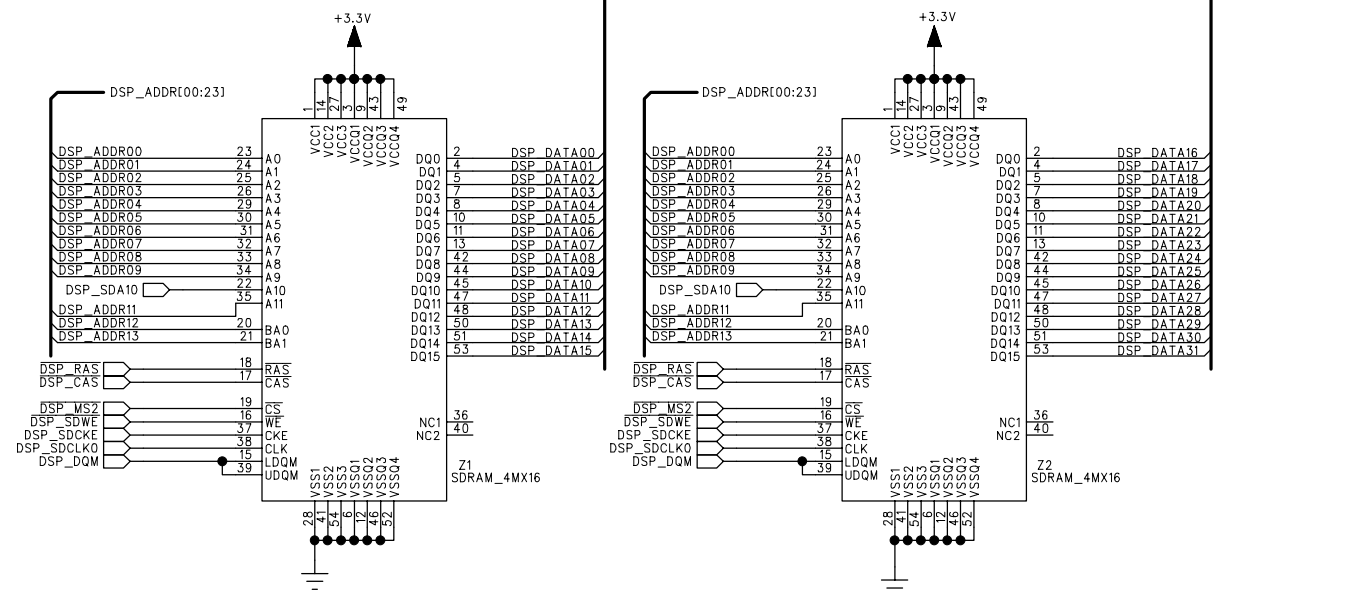

FLASH MEMORY

NOTE: The PCB layout is configured to install Either the 1M X 16 or the 4M X 16 parts but not both!

THE INFORMATION CONTAINED IN THIS DRAWING IS THE SOLE PROPERTY OF LINE 6 INC. ANY REPRODUCTION IN PART OR WHOLE WITHOUT THE WRITTEN PERMISSION OF LINE 6 INC. IS PROHIBITED

COMPANY:	LINE 6
TITLE:	SHARCTONE MAIN DSP MEMORY
PROGRAM:	PADS POWER LOGIC V5.0
REV:	E1
FILENAME:	/Sharctone Product Family/DUET 212 Combo/Electrical/ /Schematic/Main/REV E/SHARCTONE MAIN REV E1.sch
SCALE: 1:1	SIZE: C
PART NUMBER: 35-00-0121	SHEET: 6 OF 7

DRAWN:	D. MOLNAR	DATED:	1/22/02
CHECKED:	Name (F.Last)	DATED:	00/00/01

FBX CLASS FOOT CONTROLLER INTERFACE

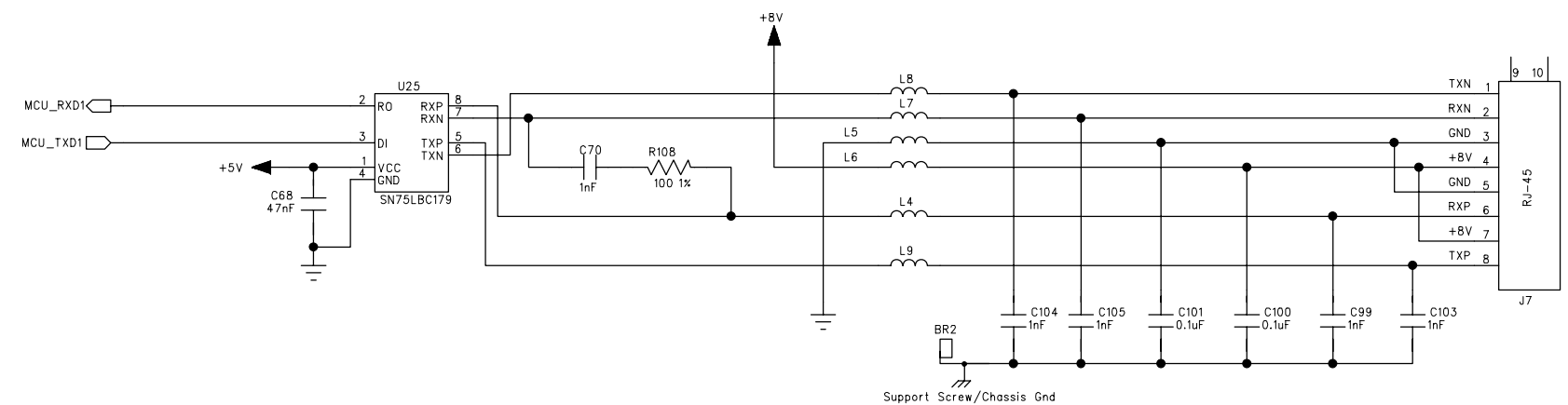

MIDI INTERFACE

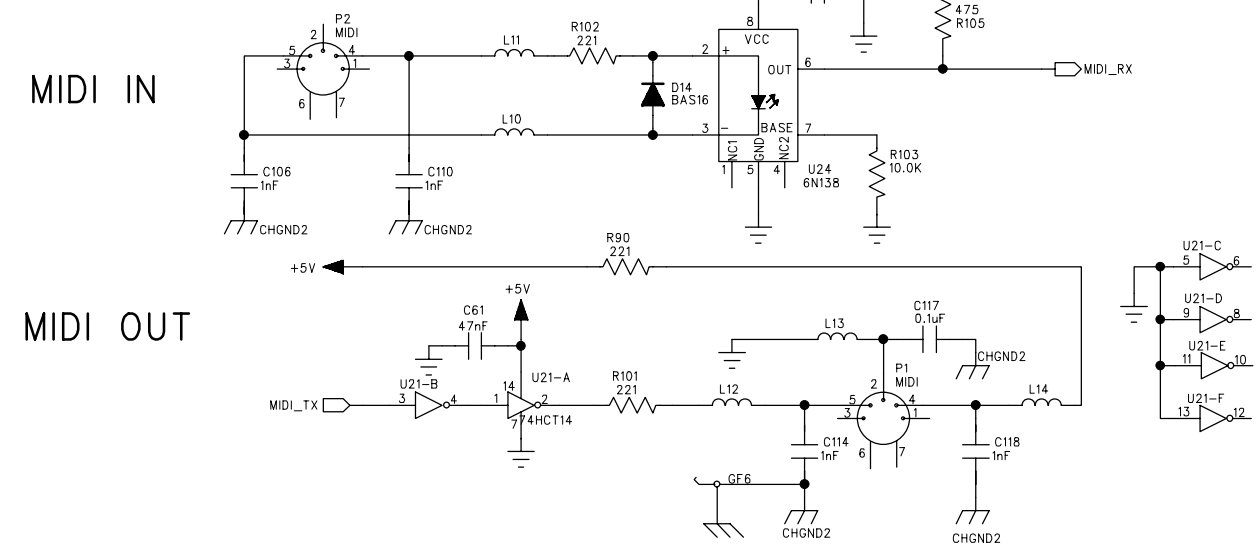

FRONT PANEL INTERFACE

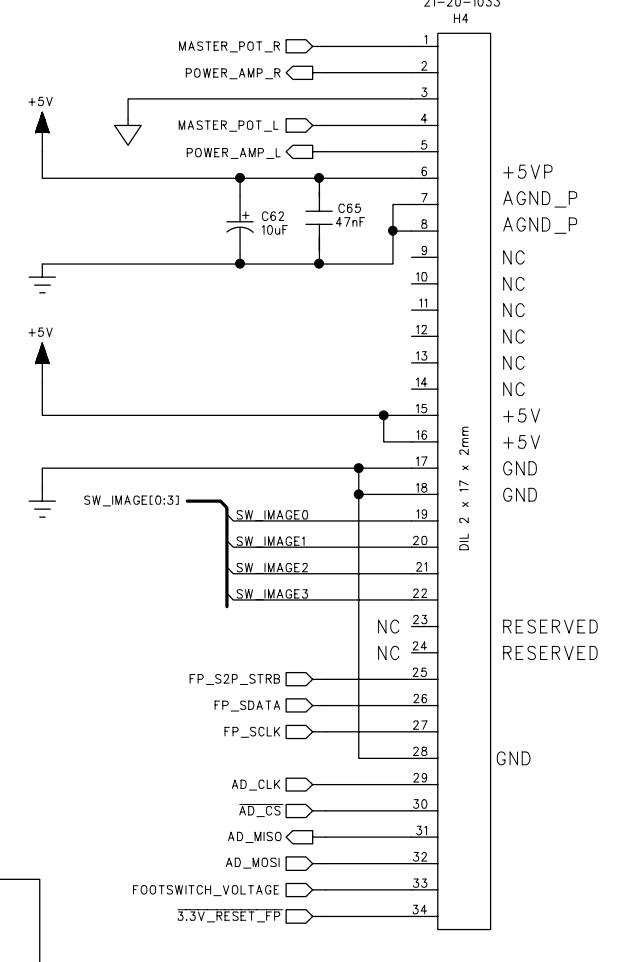

SPEAKER OUT CONNECTOR

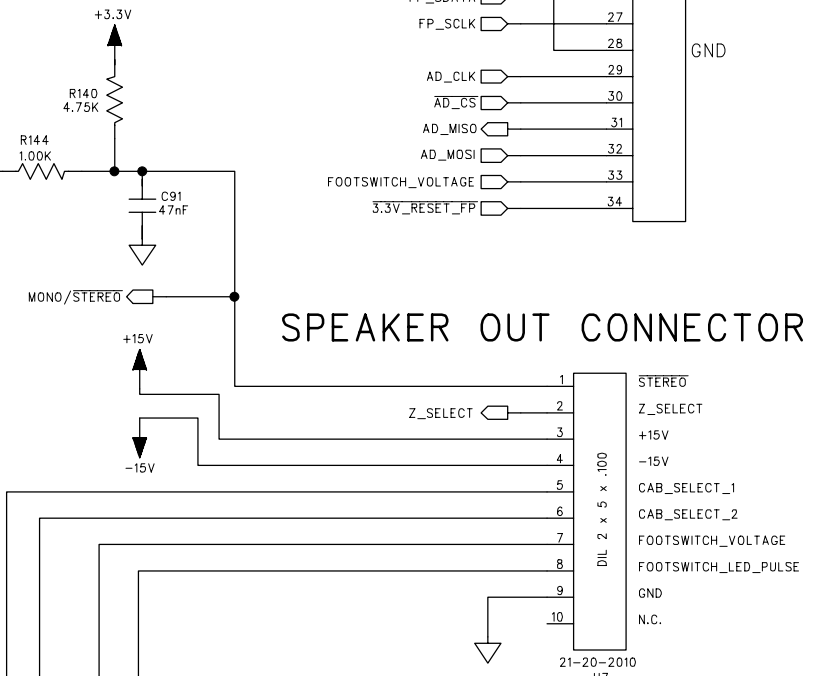

FROM FOOTSWITCH JACK (2 switch / 2 LED)

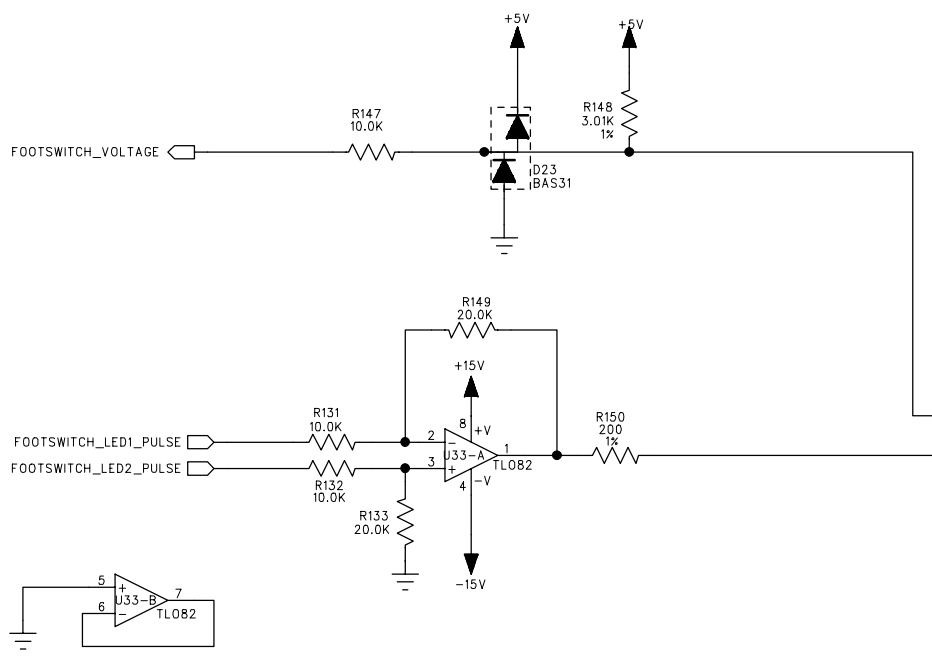

FROM CAB SELECT SWITCH

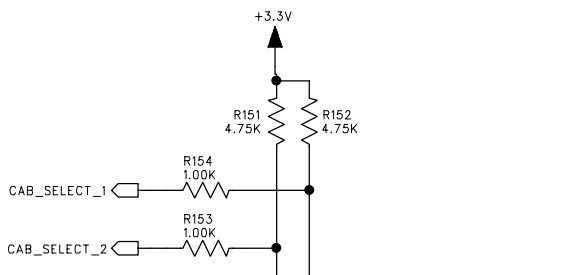

ECOs INCLUDED ON THIS SCHEMATIC/PCB REVISION		
ECO NO:	DATE:	DESCRIPTION:

THE INFORMATION CONTAINED IN THIS DRAWING IS THE SOLE PROPERTY OF LINE 6 INC. ANY REPRODUCTION IN PART OR WHOLE WITHOUT THE WRITTEN PERMISSION OF LINE 6 INC. IS PROHIBITED

COMPANY:	LINE 6
TITLE:	SHARCTONE MAIN INTERFACE
PROGRAM:	PADS POWER LOGIC V5.0
FILENAME:	/Sharctone Product Family/DUET 212 Combo/Electrical/ /Schematic/Main/REV E/SHARCTONE MAIN REV E1.sch
SCALE:	1:1
SIZE:	C
PART NUMBER:	35-00-0121
SHEET:	7 OF 7

DRAWN:	D. BLACKMORE	DATED:	3/29/2002
CHECKED:	Name (F.Last)	DATED:	00/00/01

REV: E1

6

5

4

3

2

1

*Vetta Head and Combo use the same PCB

The schematic reflects the components inserted for each respective assembly

ECOs INCLUDED ON THIS SCHEMATIC/PCB REVISION		
ECO NO:	DATE:	DESCRIPTION:
0317103	06.20.03	Incorporated rework - (2) 82K & (2) 100K res & (2) 1.5nF caps.

D

C

B

A

D

C

B

A

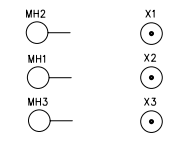
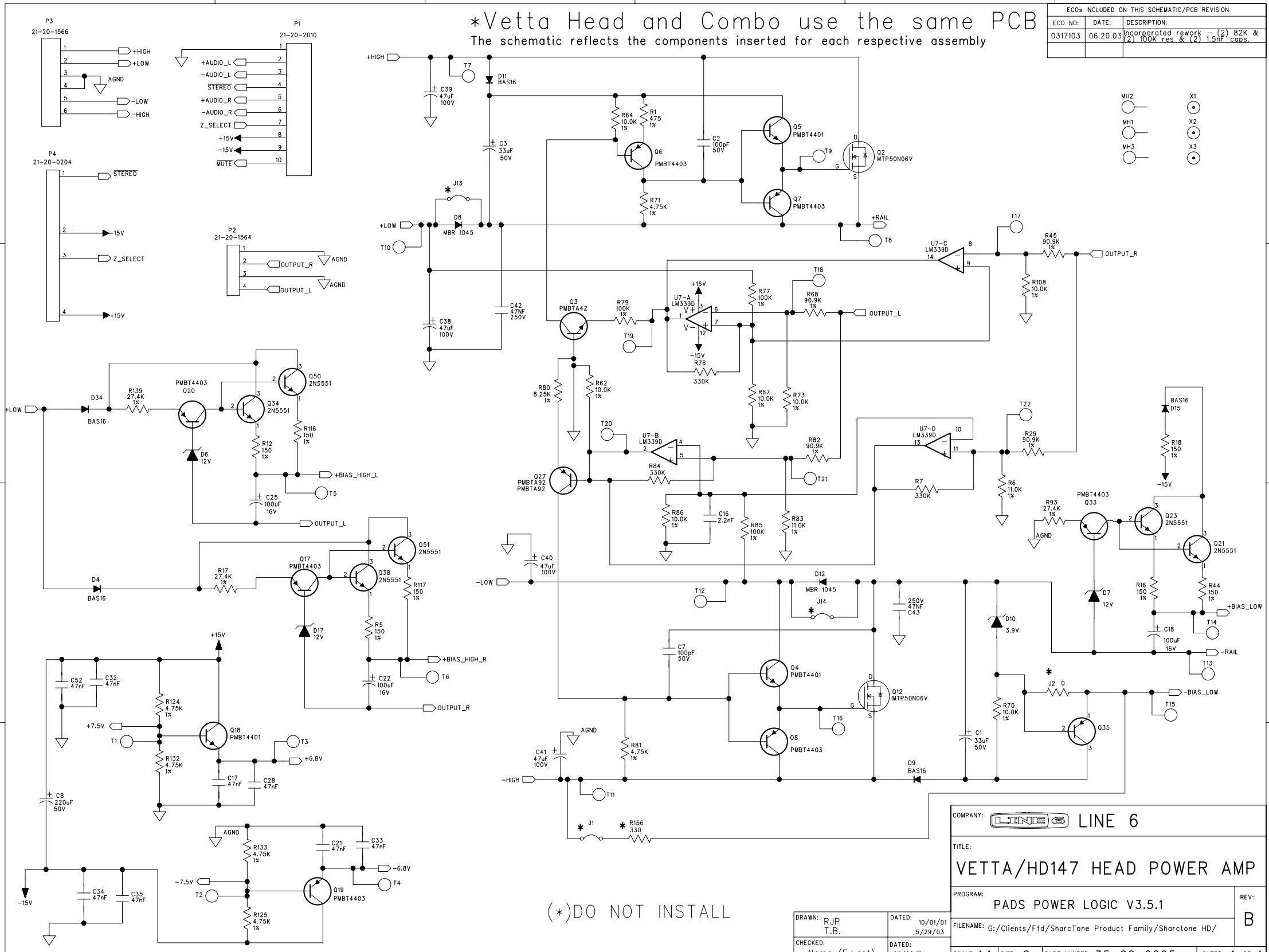

(*)DO NOT INSTALL

COMPANY: LINE 6	
TITLE: VETTA/HD147 HEAD POWER AMP	
PROGRAM: PADS POWER LOGIC V3.5.1	
REV: B	FILENAME: G:/Clients/Ffd/Sharctone Product Family/Sharctone HD/
DRAWN: RJP	DATED: 10/01/01
CHECKED: T.B.	DATED: 5/29/03
CHECKED: Name (F.Last)	DATED: 00/00/01
SCALE: 1:1	SIZE: C
PART NUMBER: 35-00-0205	SHEET: 1 OF 4

6

5

4

3

2

1

ECOs INCLUDED ON THIS SCHEMATIC/PCB REVISION		
ECO NO:	DATE:	DESCRIPTION:

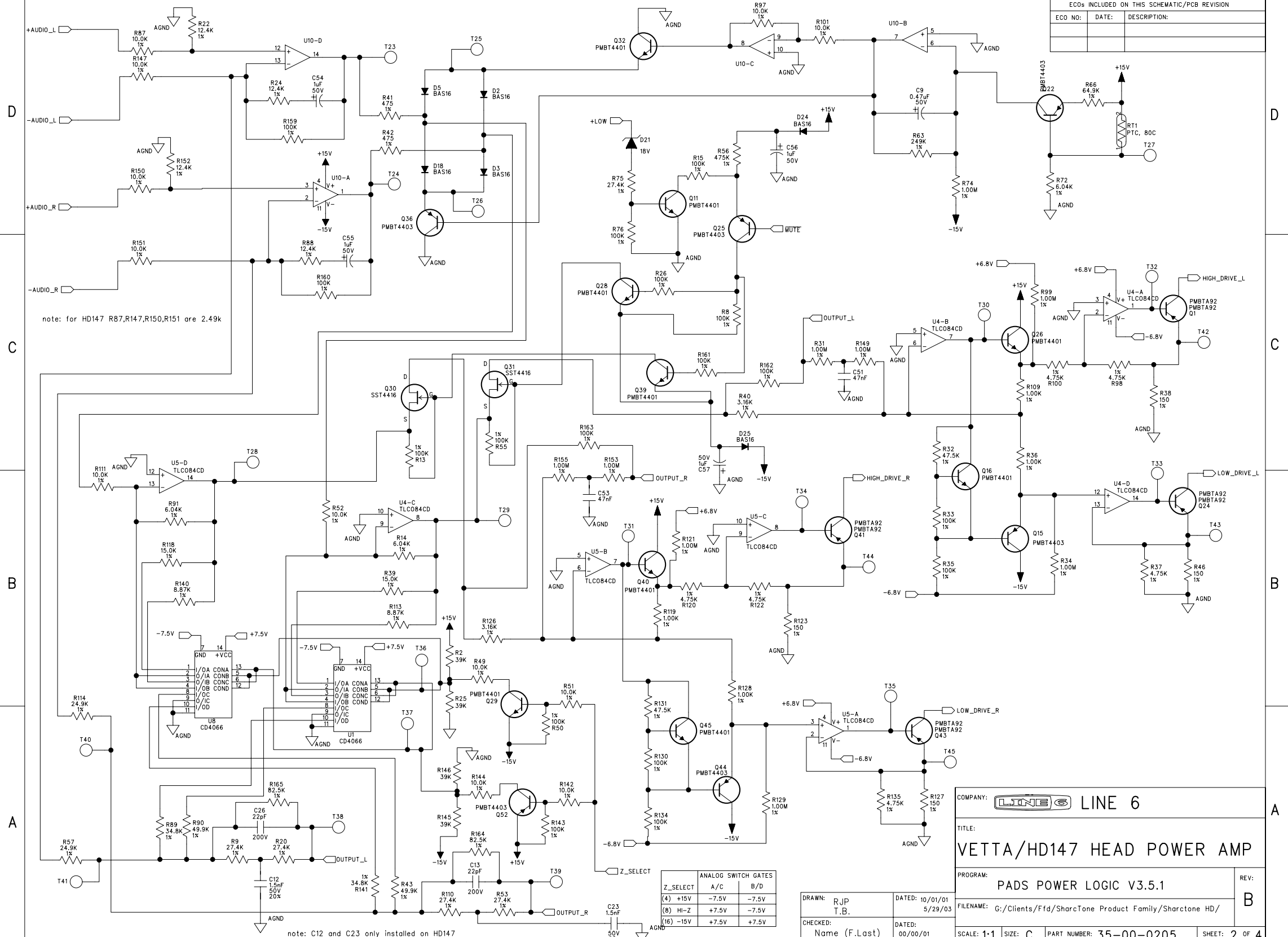

note: for HD147 R87,R147,R150,R151 are 2.49k

note: C12 and C23 only installed on HD147

Z_SELECT	ANALOG SWITCH GATES	A/C	B/D
(4) +15V	-7.5V	-7.5V	-7.5V
(8) HI-Z	+7.5V	-7.5V	-7.5V
(16) -15V	+7.5V	+7.5V	+7.5V

DRAWN: RJP
T.B.

CHECKED: Name (F.Last)

DATED: 10/01/01
5/29/03

DATED: 00/00/01

COMPANY: **LINE 6**

TITLE: **VETTA/HD147 HEAD POWER AMP**

PROGRAM: **PADS POWER LOGIC V3.5.1**

FILENAME: G:/Clients/Ffd/Sharctone Product Family/Sharctone HD/

SCALE: 1:1 SIZE: C PART NUMBER: 35-00-0205 SHEET: 2 OF 4

B

OUTPUT STAGE

ECOs INCLUDED ON THIS SCHEMATIC/PCB REVISION		
ECO NO:	DATE:	DESCRIPTION:

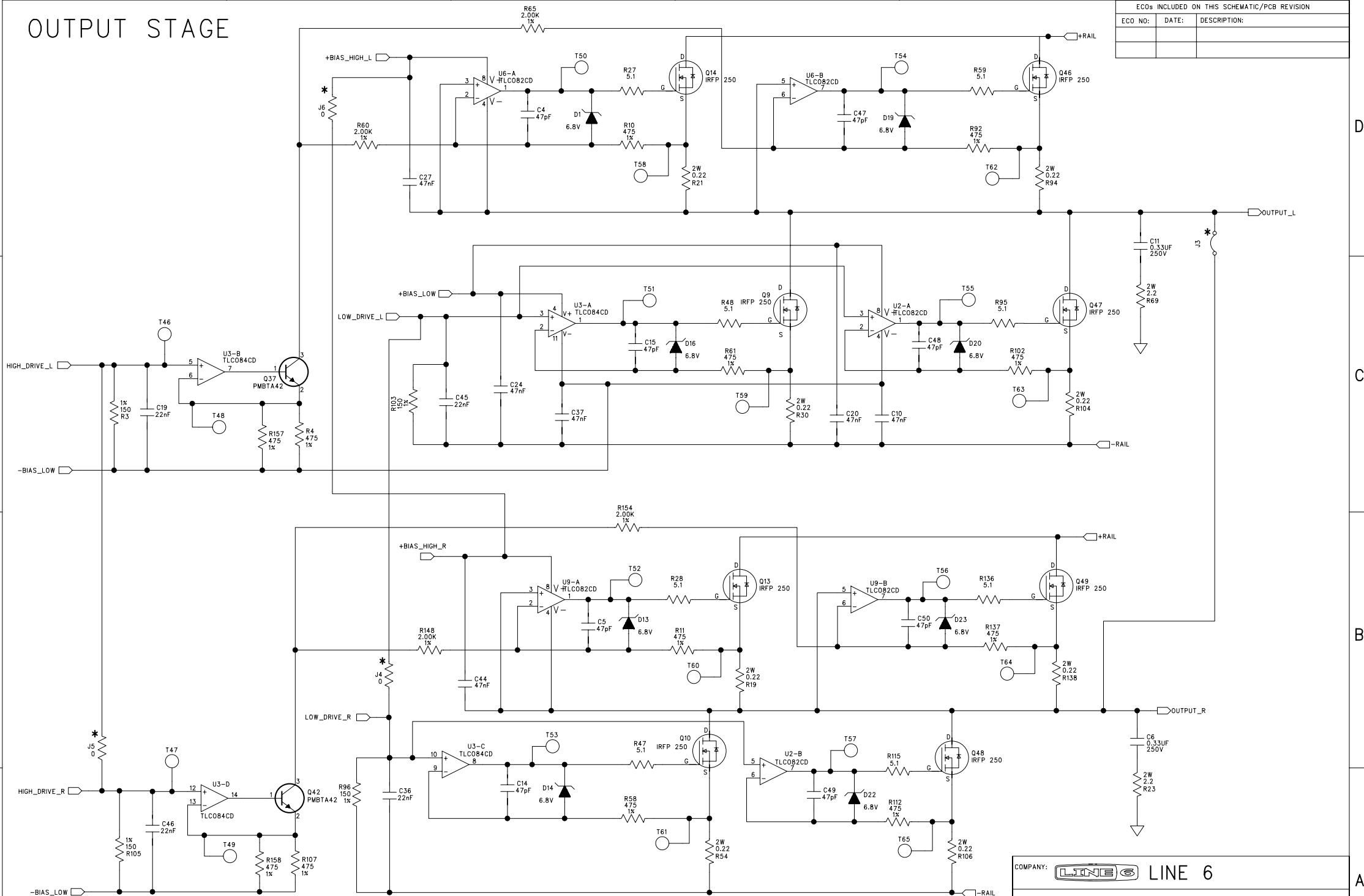

(*) DO NOT INSTALL

COMPANY: LINE 6	
TITLE: VETTA/HD147 HEAD POWER AMP	
PROGRAM: PADS POWER LOGIC V3.5.1	REV: B
FILENAME: G:/Clients/Ffd/Sharctone Product Family/Sharctone HD/	
SCALE: 1:1	SIZE: C
PART NUMBER: 35-00-0205	SHEET: 3 OF 4

DRAWN: RJP T.B.	DATED: 10/01/01 5/29/03
CHECKED: Name (F.Last)	DATED: 00/00/01

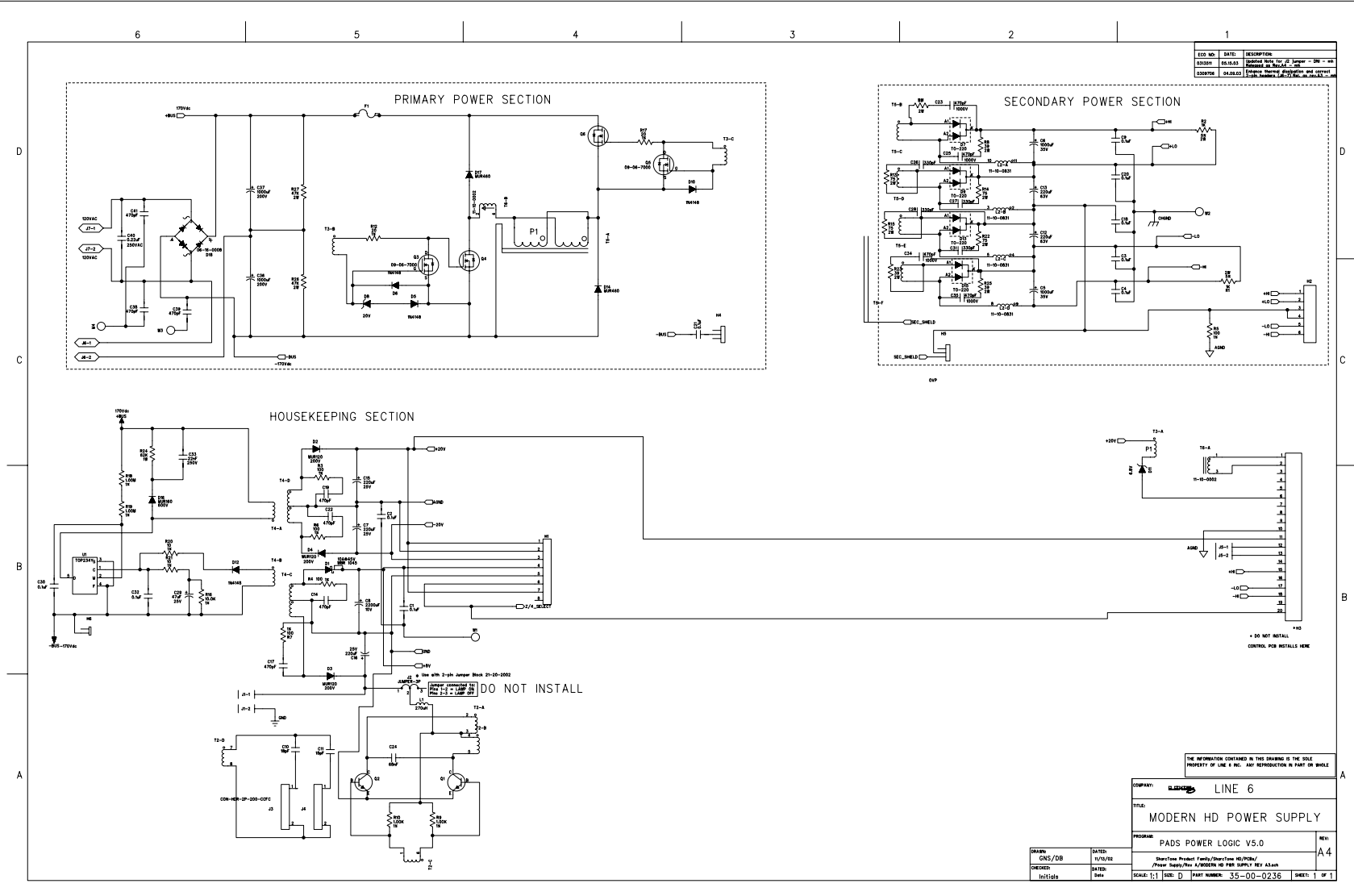

ECO NO.	DATE	DESCRIPTION
03005	04.08.03	Approved for 2003 Design - SW - 04
03006	04.08.03	Approved for 2003 Design - SW - 04
03070	04.08.03	Approved for 2003 Design - SW - 04

THE INFORMATION CONTAINED IN THIS DRAWING IS THE SOLE PROPERTY OF LINE 6 INC. ANY REPRODUCTION IN PART OR WHOLE

COMPANY:	LINE 6
TITLE:	MODERN HD POWER SUPPLY
PROGRAM:	PADS POWER LOGIC V5.0
DESIGNER:	GNS/DB
DATE:	11/19/02
CHECKED:	DATE:
INITIALS:	DATE:
SCALE:	1:1
SHEET:	1 OF 1
PART NUMBER:	35-00-0236

DRWG:	GNS/DB
DATE:	11/19/02
CHKD:	
DATE:	

REVISION RECORD			
LTR	ECO NO.	APPROVED:	DATE:
A	0301701	Released as rev.A	Gregg Stock 03/28/03

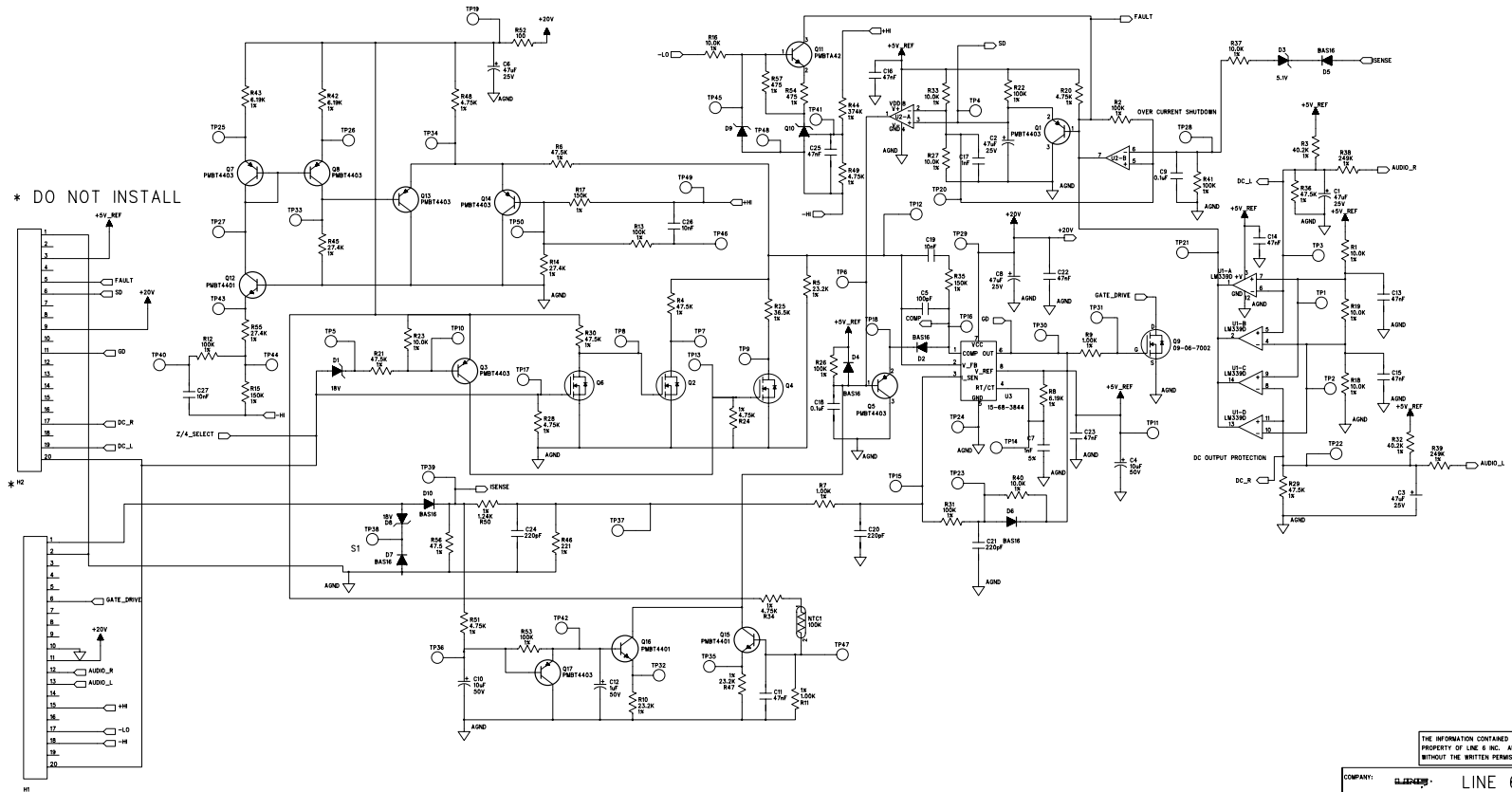

THE INFORMATION CONTAINED IN THIS DRAWING IS THE SOLE PROPERTY OF LINE 6 INC. ANY REPRODUCTION IN PART OR WHOLE WITHOUT THE WRITTEN PERMISSION OF LINE 6 INC. IS PROHIBITED.

COMPANY:	LINE 6
TITLE:	MODERN HD PS CONTROL
PROGRAM:	PADS POWER LOGIC V4.0
REV:	A

DRAWN:	DATE:	FILENAME:
Name (F.Lost)	00/00/01	
CHECKED:	DATE:	Date on F14/Clients/F14/Product/Hardware/Schematics/F14.sch
Name (F.Lost)	00/00/01	
SCALE: 1:1	SIZE: D	PART NUMBER: 35-00-0119
SHEET: 1		OF 1

6

5

4

3

2

1

HD SPEAKER OUTPUTS PCB

ECOs INCLUDED ON THIS SCHEMATIC/PCB REVISION		
ECO NO:	DATE:	DESCRIPTION:
0309704	04.09.03	Added (2) 1nF Cops (C1-2) SAVED AS REV.B - mh

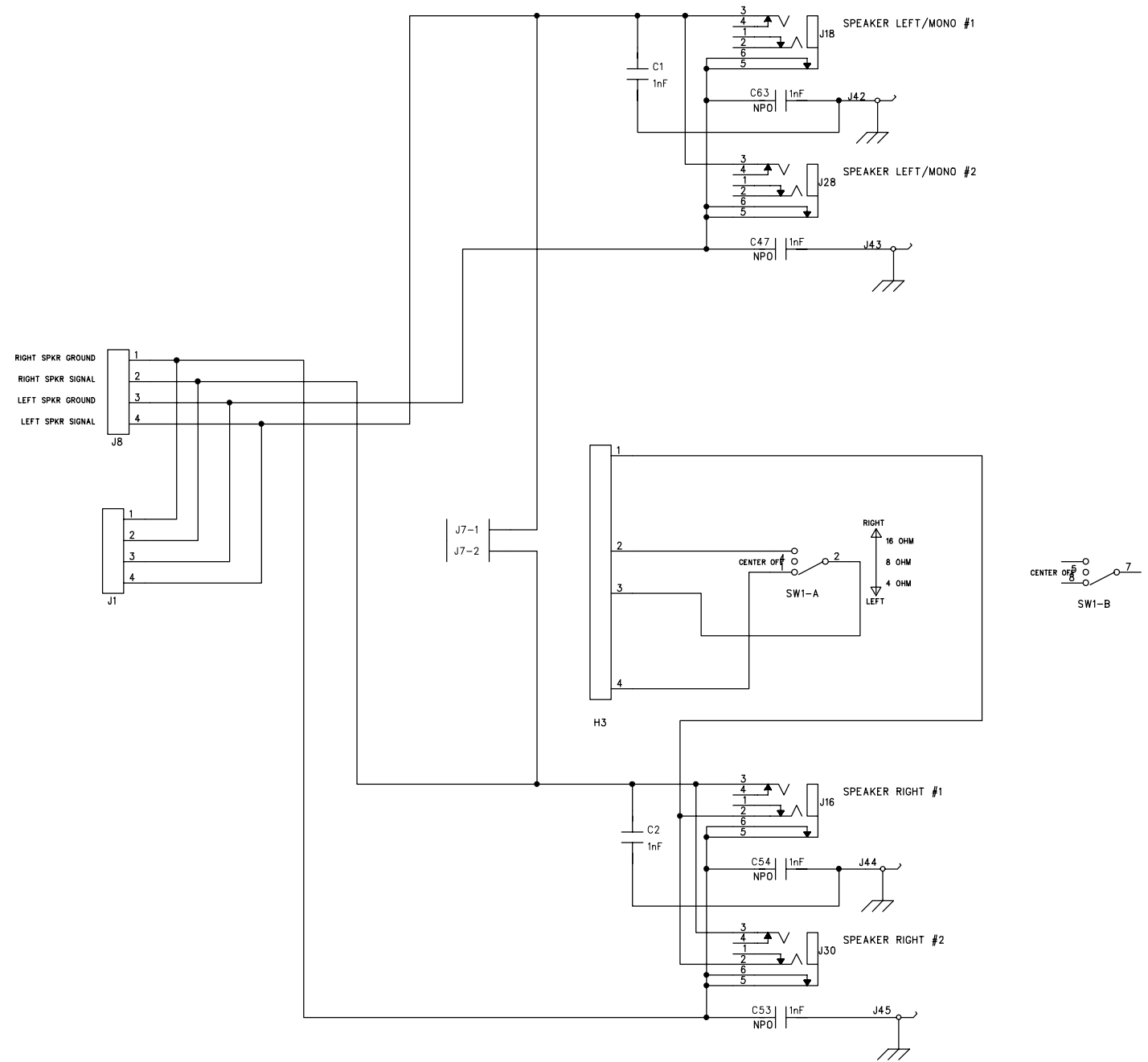

D

C

B

A

D

C

B

A

COMPANY: LINE 6

TITLE: HD SPEAKER OUTPUTS PCB

PROGRAM: PADS POWER LOGIC V5.0

FILENAME: .../Sharctone Product Family/Sharctone HD/PCBs/
/Speaker Out/Rev A/Modern HD SPKR OUT REV B.sch

SCALE: 1:1 SIZE: C PART NUMBER: 35-00-0237 SHEET: 1 OF 1

DRAWN: T Burton

DATED: Date

CHECKED: Initials

DATED: Date

REV: B

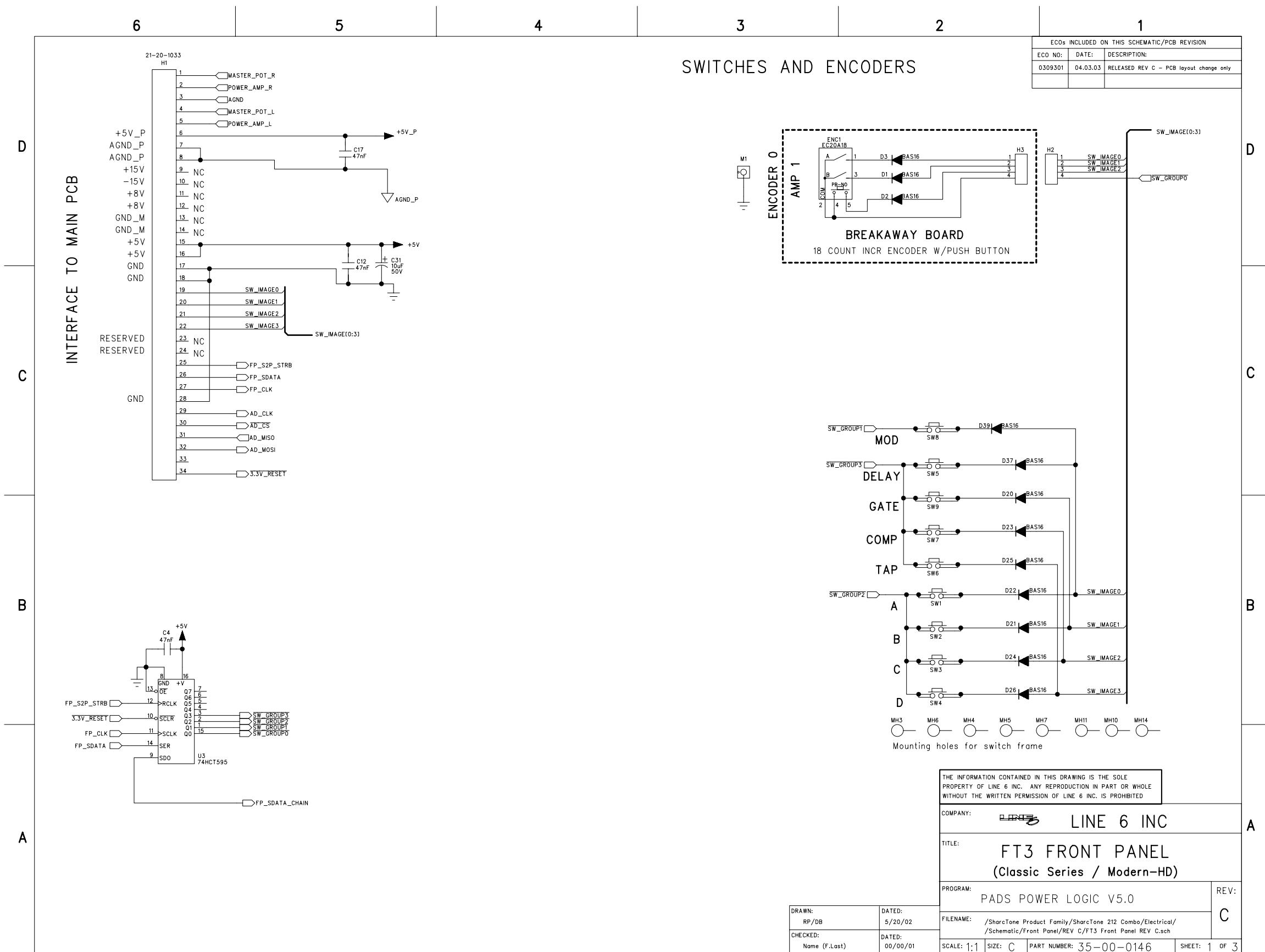

ECOs INCLUDED ON THIS SCHEMATIC/PCB REVISION		
ECO NO:	DATE:	DESCRIPTION:
0309301	04.03.03	RELEASED REV C - PCB layout change only

SWITCHES AND ENCODERS

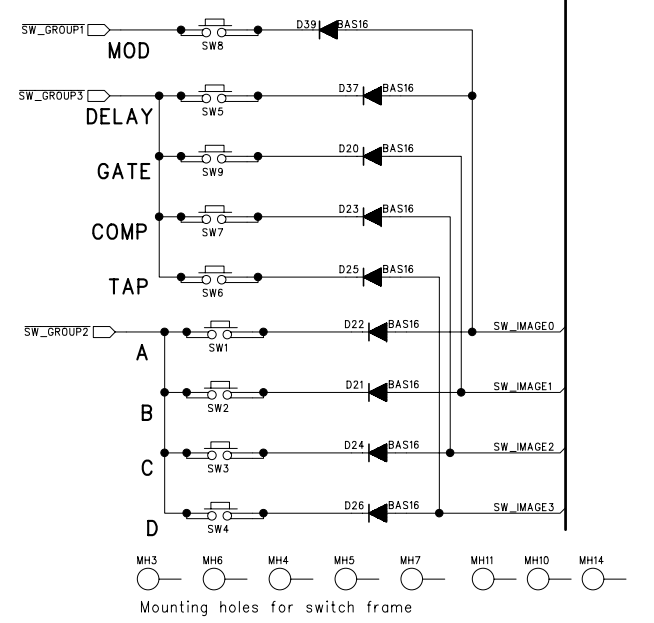
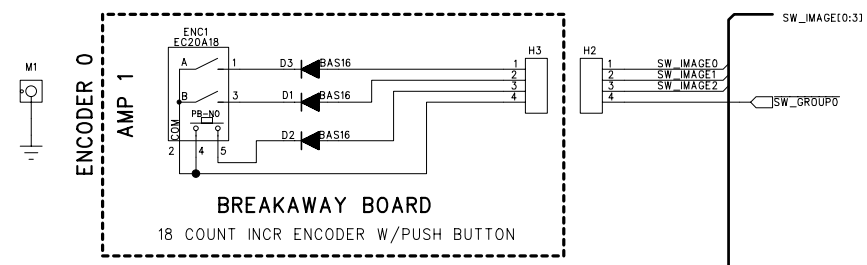

THE INFORMATION CONTAINED IN THIS DRAWING IS THE SOLE PROPERTY OF LINE 6 INC. ANY REPRODUCTION IN PART OR WHOLE WITHOUT THE WRITTEN PERMISSION OF LINE 6 INC. IS PROHIBITED			
COMPANY:		LINE 6 INC	
TITLE: FT3 FRONT PANEL (Classic Series / Modern-HD)			
PROGRAM: PADS POWER LOGIC V5.0			REV: C
DRAWN: RP/DB	DATED: 5/20/02	FILENAME: /Sharctone Product Family/Sharctone 212 Combo/Electrical/ /Schematic/Front Panel/REV C/FT3 Front Panel REV C.sch	
CHECKED: Name (F.Last)	DATED: 00/00/01	SCALE: 1:1	SIZE: C
PART NUMBER: 35-00-0146		SHEET: 1 OF 3	

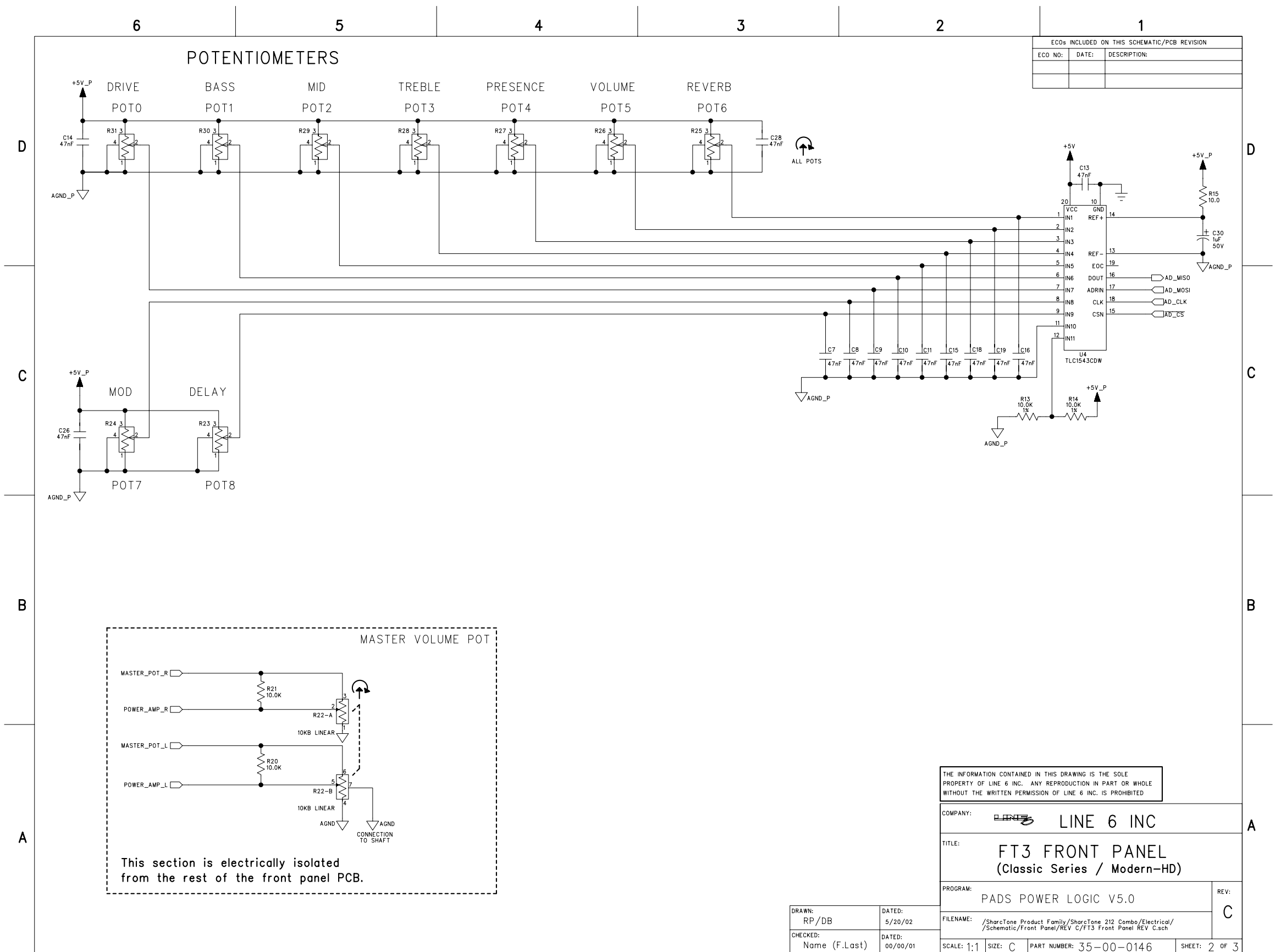

THE INFORMATION CONTAINED IN THIS DRAWING IS THE SOLE PROPERTY OF LINE 6 INC. ANY REPRODUCTION IN PART OR WHOLE WITHOUT THE WRITTEN PERMISSION OF LINE 6 INC. IS PROHIBITED.

COMPANY: **LINE 6 INC**

TITLE: **FT3 FRONT PANEL (Classic Series / Modern-HD)**

PROGRAM: **PADS POWER LOGIC V5.0**

FILENAME: /Sharctone Product Family/Sharctone 212 Combo/Electrical/Schematic/Front Panel/REV C/FT13 Front Panel REV C.sch

DRAWN: RP/DB
 CHECKED: Name (F.Last)

DATED: 5/20/02
 DATED: 00/00/01

SCALE: 1:1 SIZE: C PART NUMBER: 35-00-0146 SHEET: 2 OF 3

REV: C

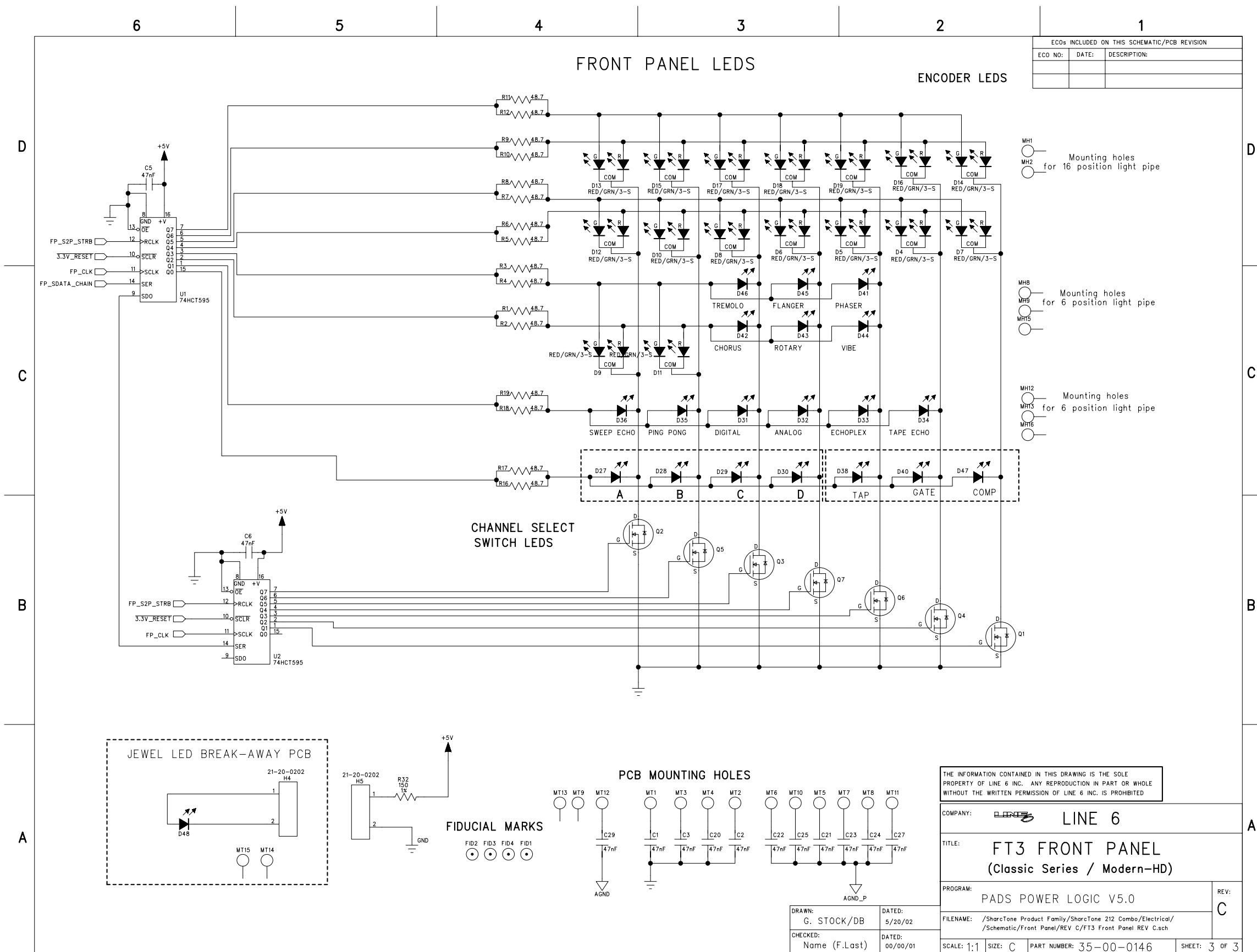

THE INFORMATION CONTAINED IN THIS DRAWING IS THE SOLE PROPERTY OF LINE 6 INC. ANY REPRODUCTION IN PART OR WHOLE WITHOUT THE WRITTEN PERMISSION OF LINE 6 INC. IS PROHIBITED

COMPANY: LINE 6		REV: C
TITLE: FT3 FRONT PANEL (Classic Series / Modern-HD)		
PROGRAM: PADS POWER LOGIC V5.0		SHEET: 3 OF 3
DRAWN: G. STOCK/DB DATED: 5/20/02		
CHECKED: Name (F.Last) DATED: 00/00/01		
FILENAME: /Sharctone Product Family/Sharctone 212 Combo/Electrical/ /Schematic/Front Panel/REV C/FT3 Front Panel REV C.sch	SCALE: 1:1 SIZE: C PART NUMBER: 35-00-0146	

6

5

4

3

2

1

REVISION RECORD			
LTR	ECO NO:	APPROVED:	DATE:

PER ECO# 223903 - CORRECTED PCB SOLDER MASK PROBLEM

GUITAR INPUT PCB

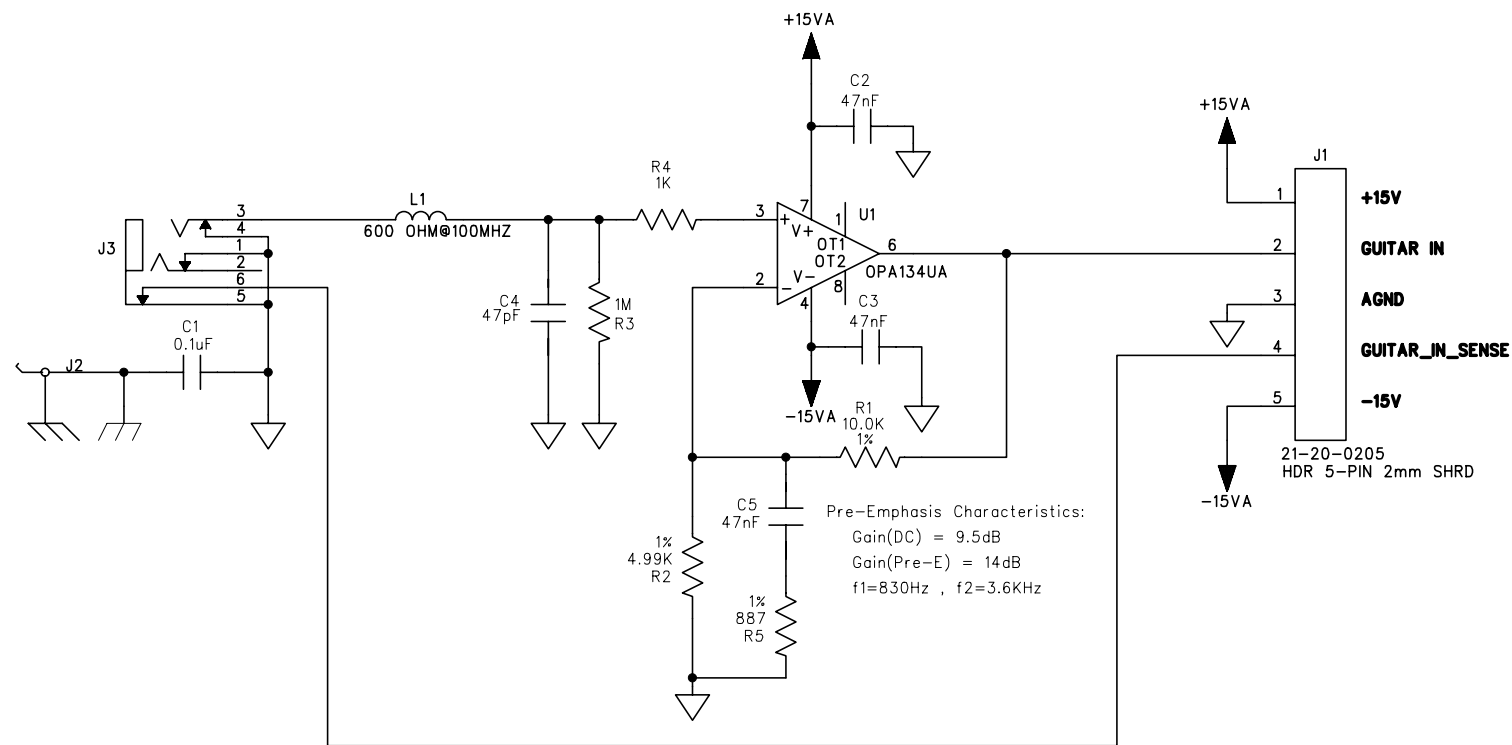

COMPANY:		LINE 6	
TITLE:		DUET GUITAR INPUT PCB	
PROGRAM:		PADS POWER LOGIC V4.0	REV: C
FILENAME:		SHARCTONE Product Family/DUET 212 Combo/Electrical/ /Schematic/GUITAR IN/REV C/DUET GUITAR IN REV C.SCH	
SCALE: 1:1	SIZE: B	PART NUMBER: 35-00-0169	SHEET: 1 OF 1

DRAWN: D. Blackmore	DATED: Date 7/10/02
CHECKED: Initials	DATED: Date

D

C

B

A

D

C

B

A

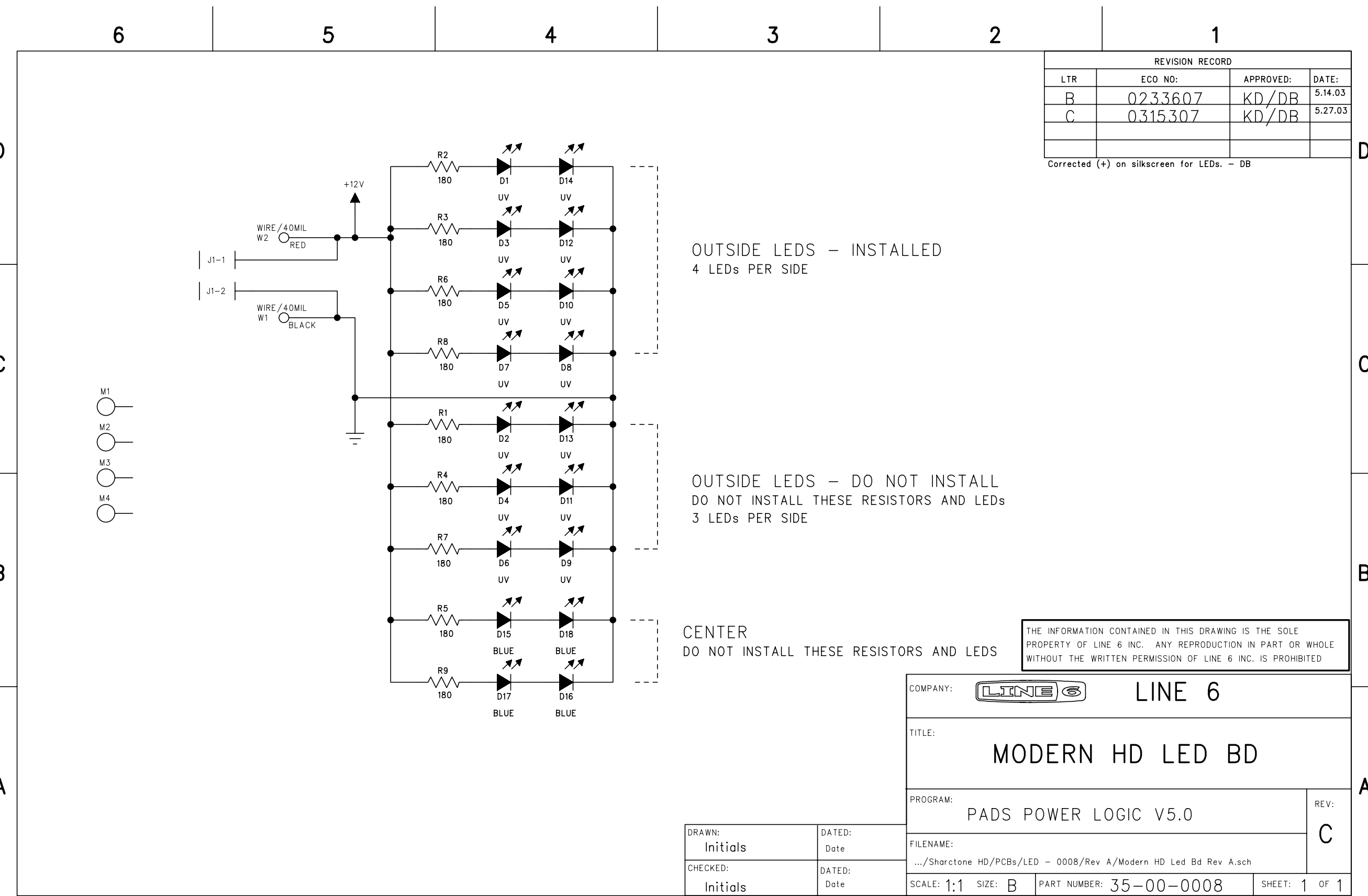

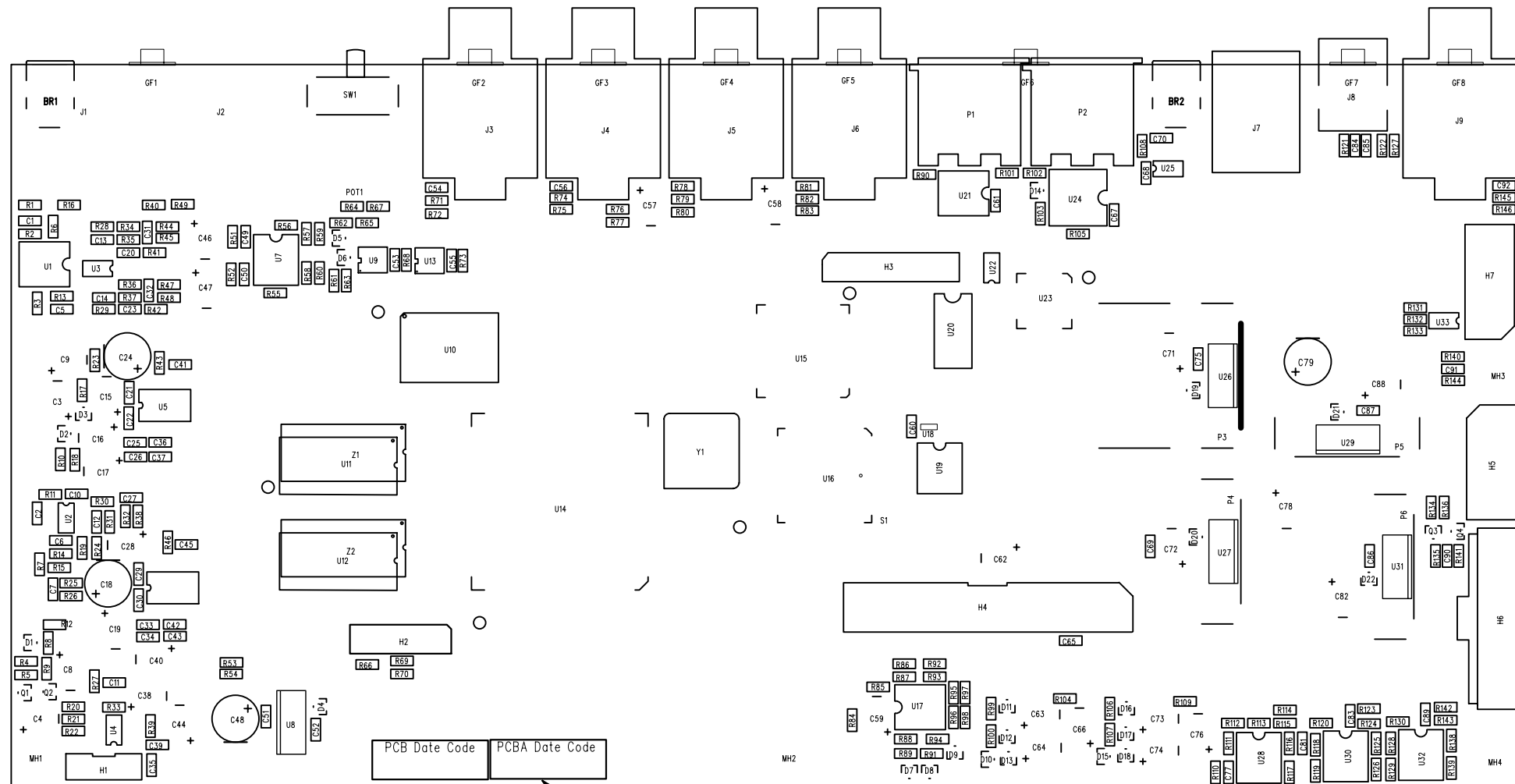
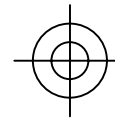
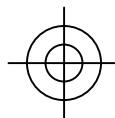

Place PCBA date code here per note

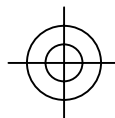

DATE CODE REQUIREMENTS

- 1) Silkscreen date code for bare PCB fabrication in area marked on drawing.
- 2) Place date code stamp or sticker for finished PCBA in area marked on drawing.

ASSEMBLY TOP

THE INFORMATION CONTAINED IN THIS DRAWING IS THE SOLE PROPERTY OF LINE 6 INC. ANY REPRODUCTION IN PART OR WHOLE WITHOUT THE WRITTEN PERMISSION OF LINE 6 INC. IS PROHIBITED

COMPANY:		LINE 6
PROGRAM:	PADS POWER PCB V5.0	
FILE:	\\Sharctone Product Family\Duet 212 Combo\Electrical\PCB\Sharctone Family Main\REV E\SHARCTONE MAIN REV E.pcb	
SCALE:	1:1	REV: E
DATE:	DECEMBER 20, 2002	
TITLE:	Sharctone Main Board	

PART # 35-00-0121

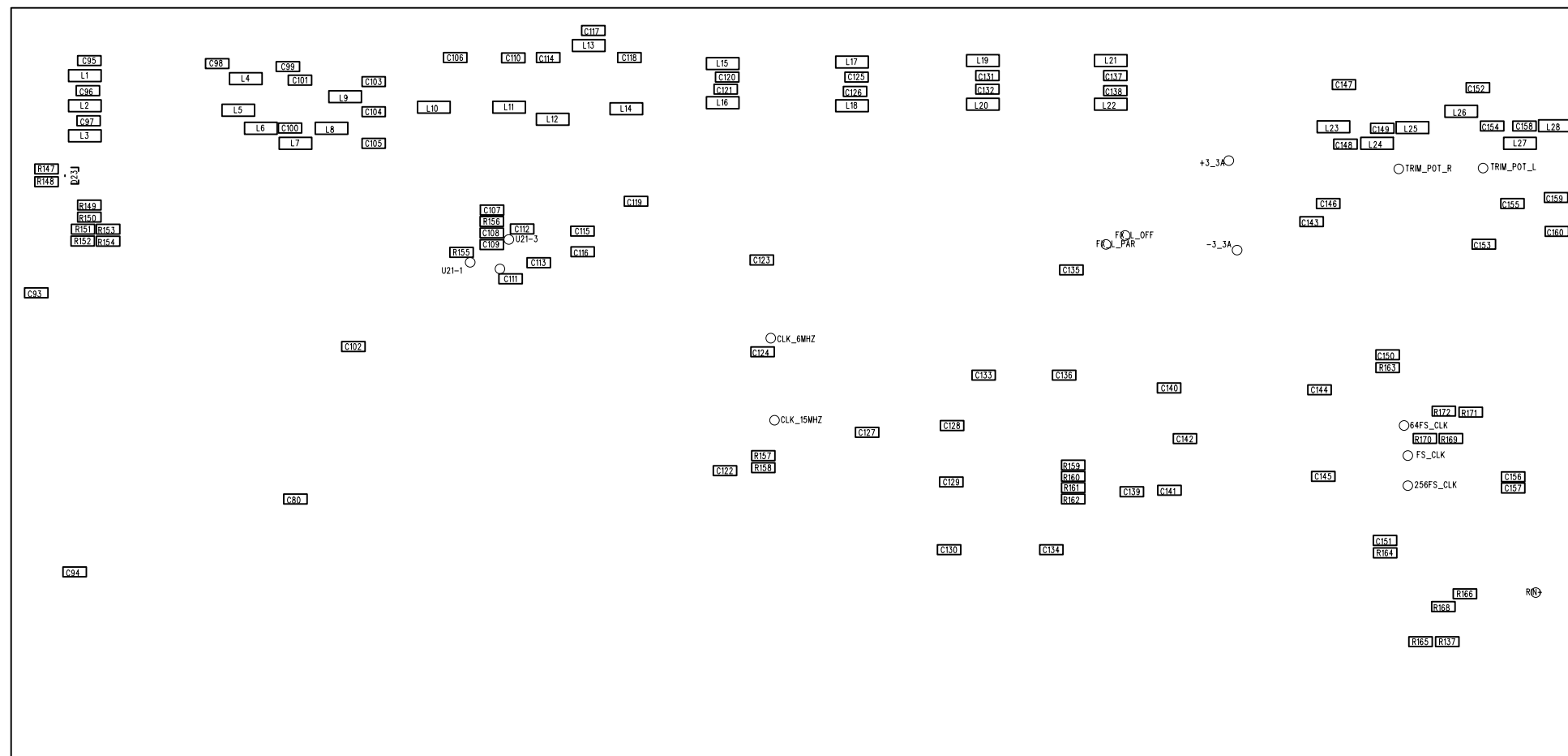
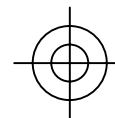
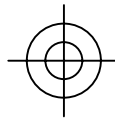

ASSEMBLY BOTTOM

THE INFORMATION CONTAINED IN THIS DRAWING IS THE SOLE PROPERTY OF LINE 6 INC. ANY REPRODUCTION IN PART OR WHOLE WITHOUT THE WRITTEN PERMISSION OF LINE 6 INC. IS PROHIBITED

COMPANY: LINE 6	
PROGRAM: PADS POWER PCB V5.0	
FILE: /Sharctone Product Family/Duet 212 Combo/Electrical/PCB/Sharctone Family Main/REV E/SHARCTONE MAIN REV E.pcb	
SCALE: 1:1	REV: E
DATE: DECEMBER 20, 2002	
TITLE: Sharctone Main Board	

PART # 35-00-0121

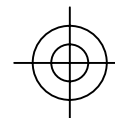

ASSEMBLY DRAWING BOTTOM

THE INFORMATION CONTAINED IN THIS DRAWING IS THE SOLE PROPERTY OF LINE 6 INC. ANY REPRODUCTION IN PART OR WHOLE WITHOUT THE WRITTEN PERMISSION OF LINE 6 INC. IS PROHIBITED

COMPANY: LINE 6	
PROGRAM: PADS POWER PCB V5.0	
FILE: \Sharctone Product Family\Duet 212 Combo\Electrical\PCB\Sharctone Family Main\REV E\SHARCTONE MAIN REV E.pcb	
SCALE: 1:1	REV: E
DATE: DECEMBER 20, 2002	
TITLE: Sharctone Main Board	

PART # 35-00-0121

DATE CODE REQUIREMENTS

- 1) Silkscreen date code for bare PCB fabrication in area marked on drawing.
- 2) Place date code stamp or sticker for finished PCBA in area marked on drawing.

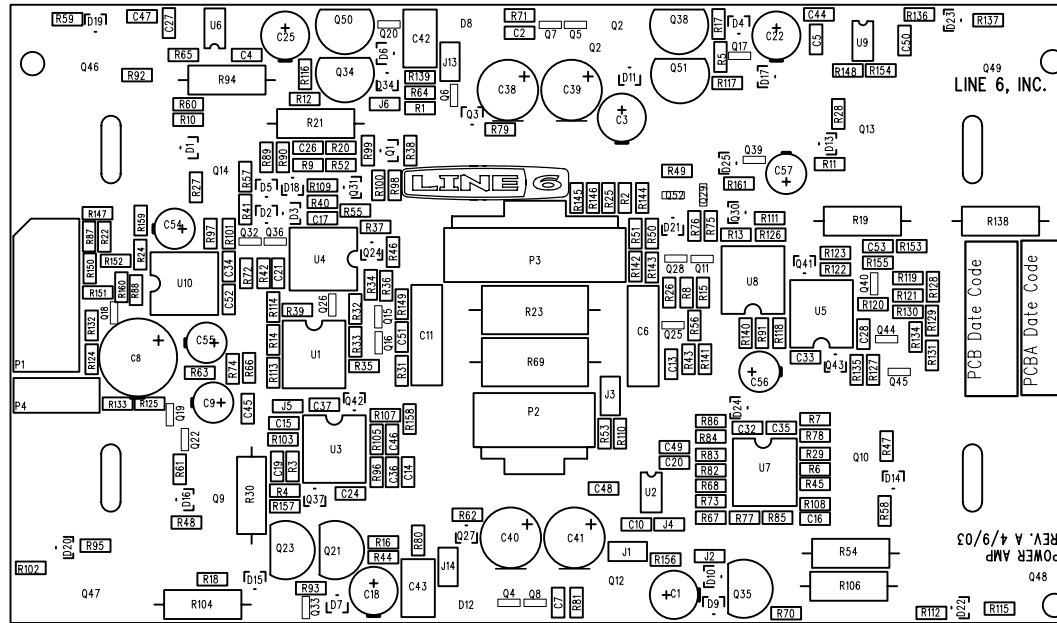

ASSEMBLY TOP

COMPANY:		 LINE 6 INC.	
PROGRAM: PADS POWER PCB V5.0			
FILE: \\Sharctone HD\PCBs\Power Amp\Modern HD Power Amp Rev B.pcb			
SCALE: NONE	REV: B	DATE: MAY 30, 2003	
TITLE: MODERN HD POWER AMP		DRAWING NO: 35-00-0205	
THE INFORMATION CONTAINED IN THIS DRAWING IS THE SOLE PROPERTY OF LINE 6 INC. ANY REPRODUCTION IN PART OR WHOLE WITHOUT THE WRITTEN PERMISSION OF LINE 6 INC. IS PROHIBITED			

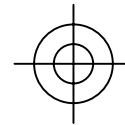
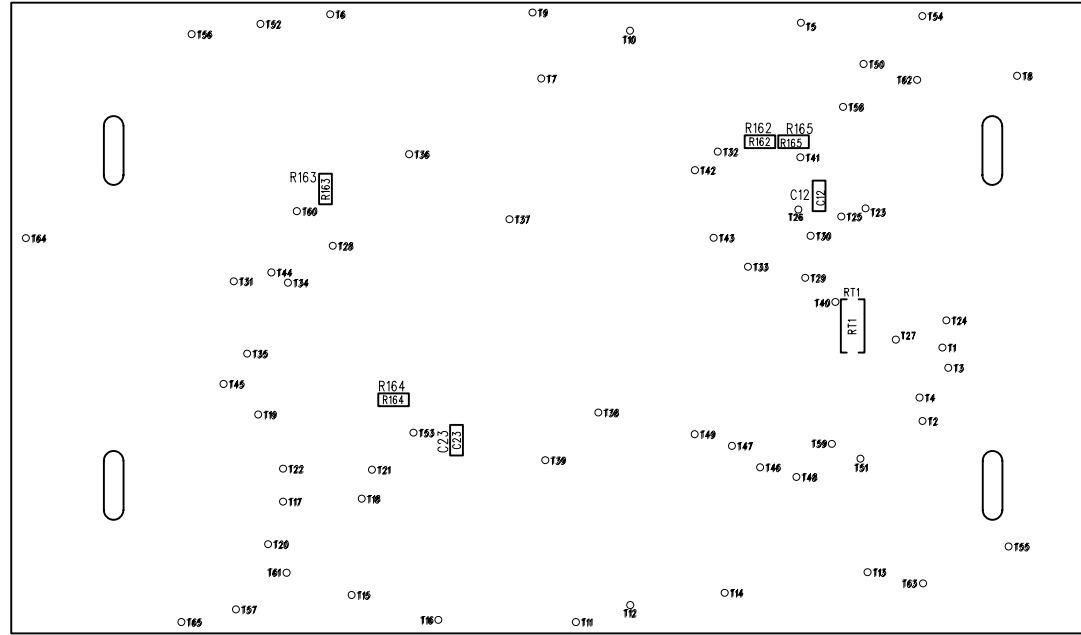
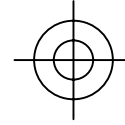
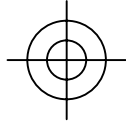

ASSEMBLY BOTTOM	
COMPANY:  LINE 6 INC.	
PROGRAM: PADS POWER PCB V3.0	
FILE: /ShareTone HD/PCBs/Power Amp/Modern HD Power Amp Rev B.pcb	
SCALE: NONE	REV: B
DATE: MAY 30 2003	
DRAWING NO: 35-00-0205	TITLE: MODERN HD POWER AMP
THE INFORMATION CONTAINED IN THIS DRAWING IS THE SOLE PROPERTY OF LINE 6 INC. ANY REPRODUCTION IN PART OR WHOLE WITHOUT THE WRITTEN PERMISSION OF LINE 6 INC. IS PROHIBITED	

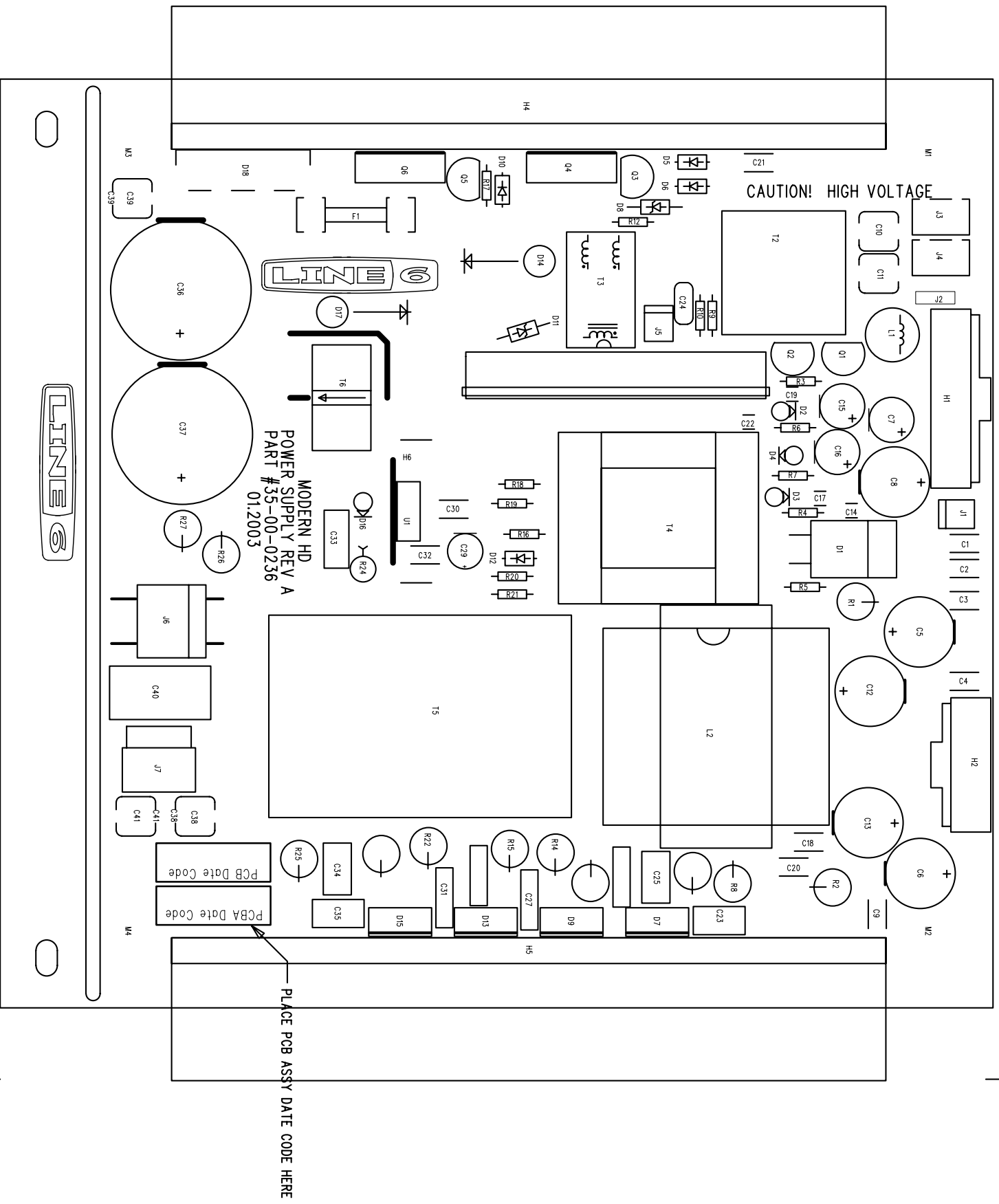
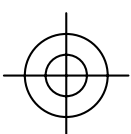
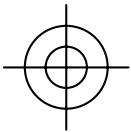

DATE CODE REQUIREMENTS

- 1) Silkscreen date code for bare PCB fabrication in area marked on drawing.
- 2) Place date code stamp or sticker for finished PCBA in area marked on drawing.

ASSEMBLY TOP

THE INFORMATION CONTAINED IN THIS DRAWING IS THE SOLE PROPERTY OF LINE 6 INC. ANY REPRODUCTION IN PART OR WHOLE WITHOUT THE WRITTEN PERMISSION OF LINE 6 INC. IS PROHIBITED

COMPANY: **LINE 6 INC.**

PROGRAM: PADS POWER PCB 5.0

FILE: \\ShareTone Product Family\ShareTone HD\PCBs\Power Supply\Rev A\MODERN HEAD POWER SUPPLY REV A.pcb

SCALE: NONE REV: A DATE: JANUARY 24, 2003

TITLE: MODERN HEAD POWER SUPPLY DRAWING NO: 35-00-0236

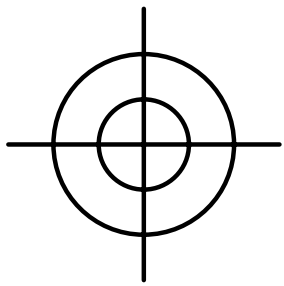
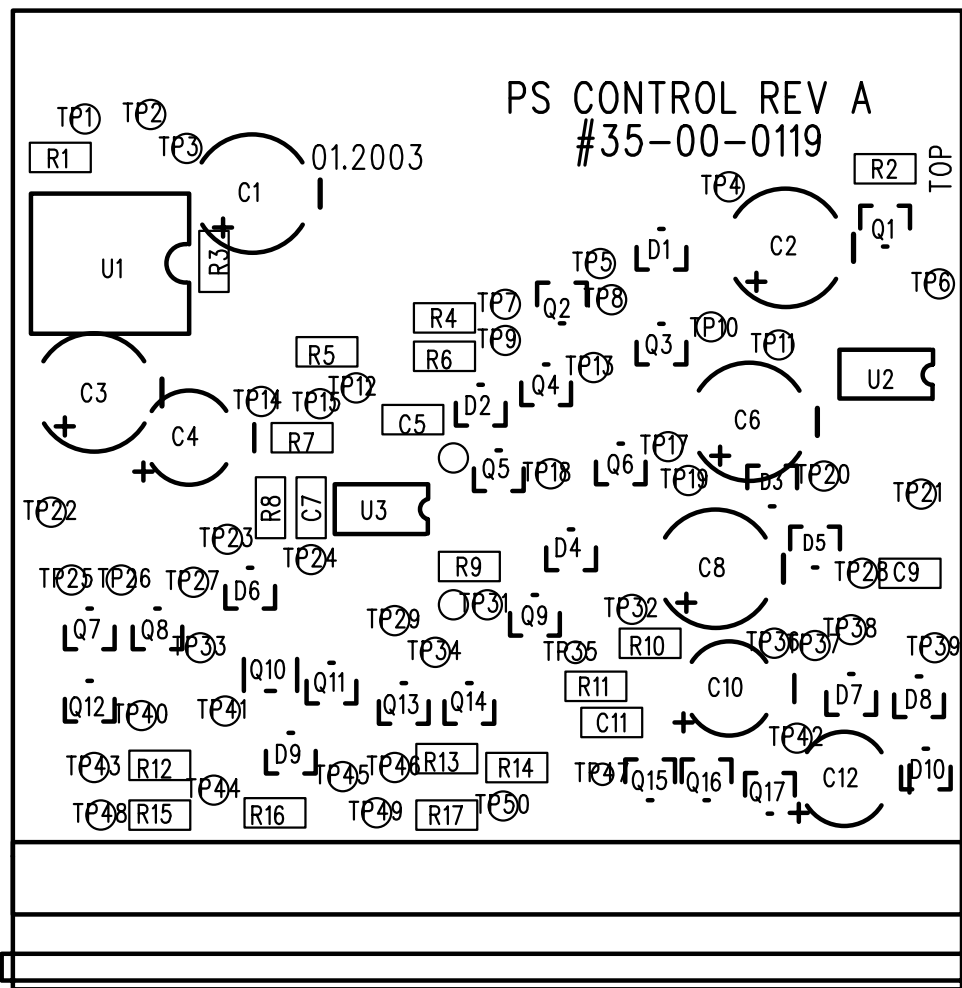
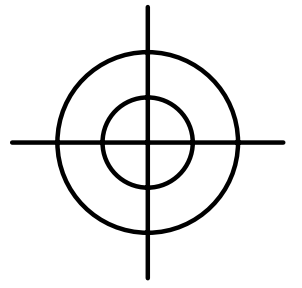
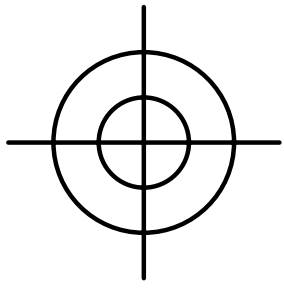

ASSEMBLY TOP

THE INFORMATION CONTAINED IN THIS DRAWING IS THE SOLE PROPERTY OF LINE 6 INC. ANY REPRODUCTION IN PART OR WHOLE WITHOUT THE WRITTEN PERMISSION OF LINE 6 INC. IS PROHIBITED

LINE 6 **LINE 6 Inc.**

PROGRAM: PADS POWER PCB V5.0

FILE: ...\Sharctone HD\PCBs\PS Control\REV A\PS Control Rev A.pcb

SCALE: 1:1	REV: A	DATE: JANUARY 27, 2003
-------------------	---------------	-------------------------------

**TITLE: MODERN HD P.S. CONTROL
PART # 35-00-0119**

DATE CODE REQUIREMENTS

- 1) Silkscreen date code for bare PCB fabrication in area marked on drawing.
- 2) Place date code stamp or sticker for finished PCBA in area marked on drawing.

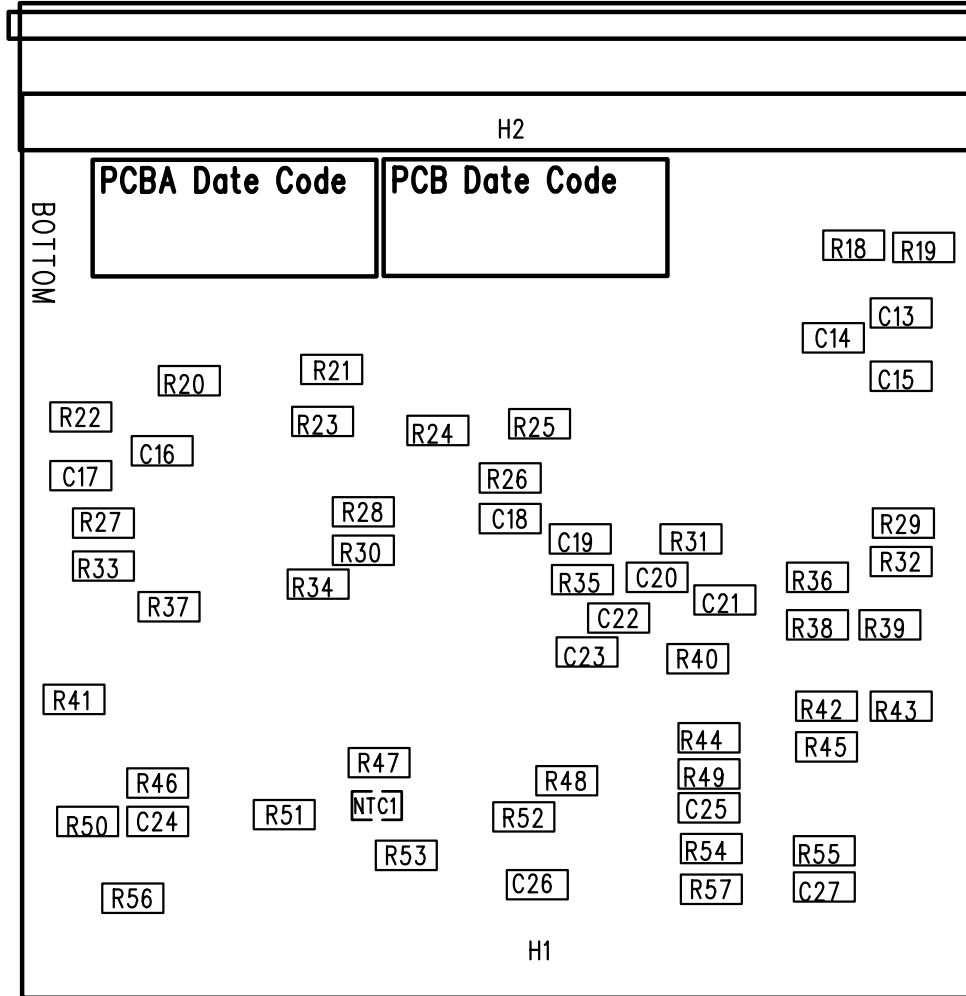
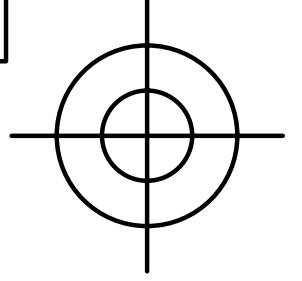
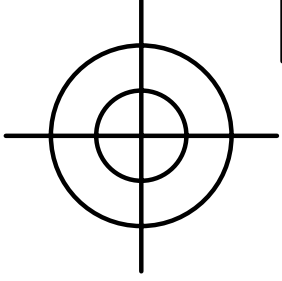

ASSEMBLY BOTTOM

WITHOUT THE WRITTEN PERMISSION OF LINE & INC. IS PROHIBITED
 PROPERTY OF LINE & INC. ANY REPRODUCTION IN PART OR WHOLE
 THE INFORMATION CONTAINED IN THIS DRAWING IS THE SOLE

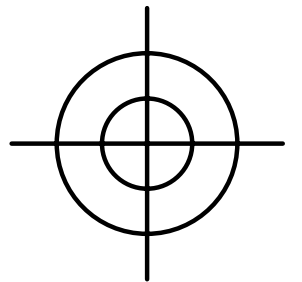

LINE & Inc.

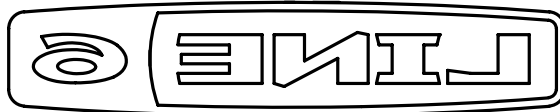

PROGRAM: PADS POWER PCB V5.0

FILE: .../Sharestone HD/PCBs/P2 Control/REV A/P2 Control Rev A.pcb

SCALE: 1:1 REV: A DATE: JANUARY 27, 2003

TITLE: MODERN HD P.2. CONTROL PART # 35-00-019

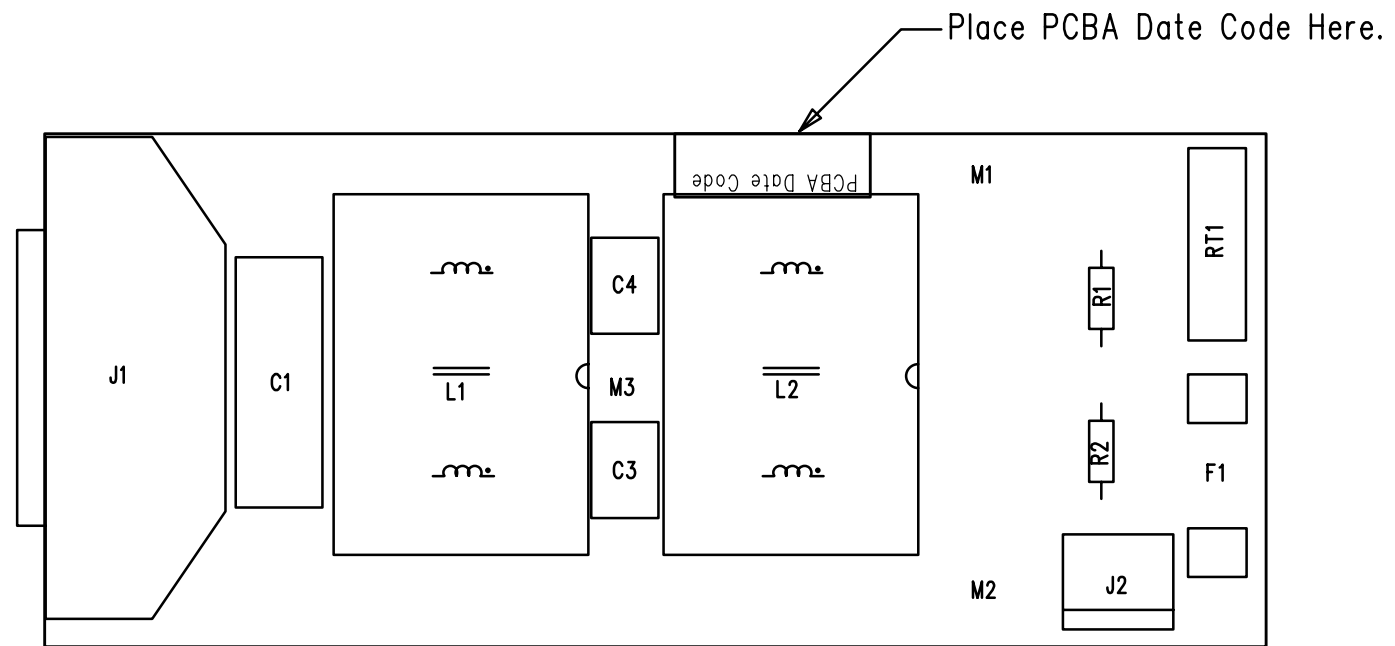
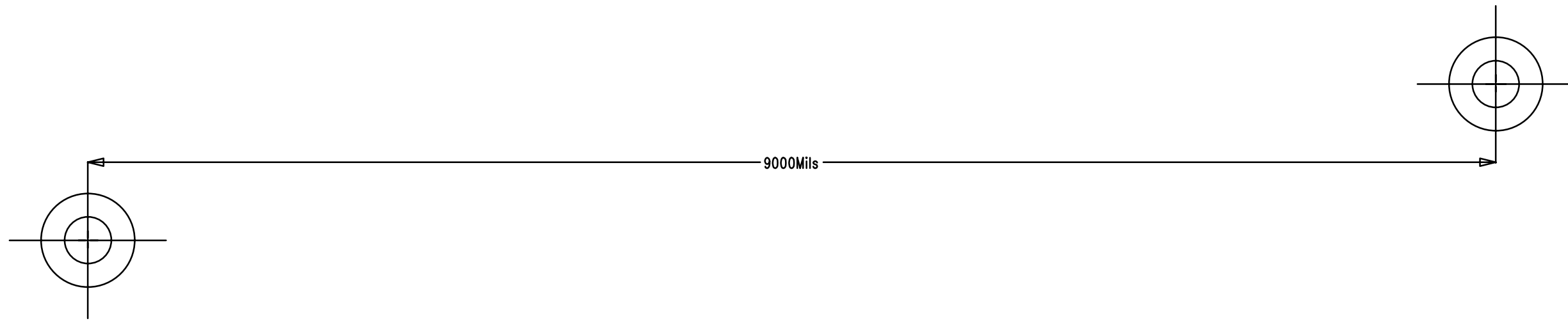

ASSEMBLY TOP

DATE CODE REQUIREMENTS

- 1) Silkscreen date code for bare PCB fabrication in area marked on drawing.
- 2) Place date code stamp or sticker for finished PCBA in area marked on drawing.

THE INFORMATION CONTAINED IN THIS DRAWING IS THE SOLE PROPERTY OF LINE 6 INC. ANY REPRODUCTION IN PART OR WHOLE WITHOUT THE WRITTEN PERMISSION OF LINE 6 INC. IS PROHIBITED	
COMPANY: LINE 6 INC.	
PROGRAM: PADS POWER PCB 3.5.1	
FILE: Data on Ffd/Clients/FFD/HDII/Hardware/Pcb/HDII LINE FILTER REV B.PCB	
SCALE: NONE	REV: B
DATE: MAR 5, 2001	
TITLE: HDII LINE FILTER	DRAWING NO: 35-00-4001

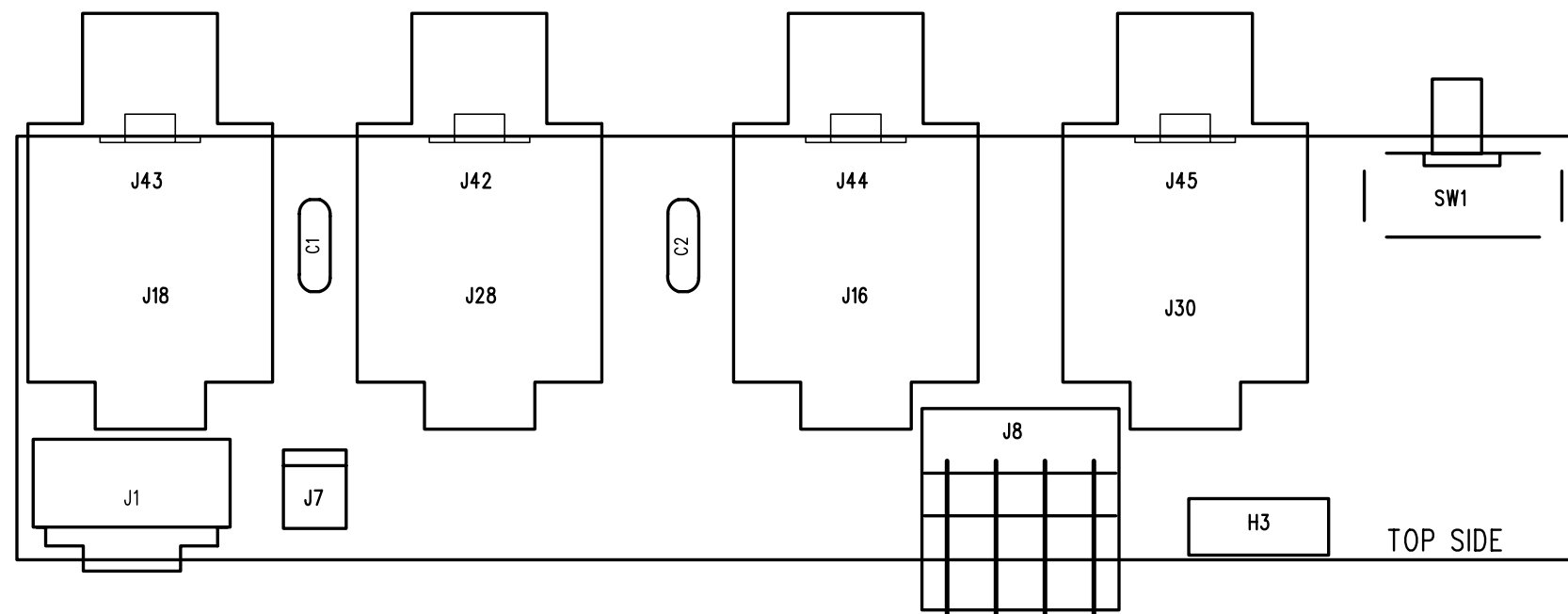
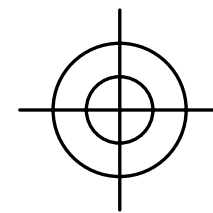
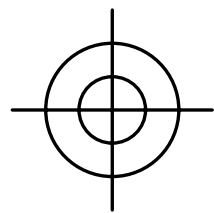

ASSEMBLY TOP

THE INFORMATION CONTAINED IN THIS DRAWING IS THE SOLE PROPERTY OF LINE 6 INC. ANY REPRODUCTION IN PART OR WHOLE WITHOUT THE WRITTEN PERMISSION OF LINE 6 INC. IS PROHIBITED

COMPANY:



LINE 6 INC.

PROGRAM: PADS POWER PCB V5.0

FILE: \Sharctone HD\PCBs\Speaker Out\Rev A\Modern HD Speaker Out Rev B.pcb

SCALE: NONE REV: B

DATE: APRIL 7, 2003

TITLE: MODERN HEAD
SPEAKER OUTPUTS

DRAWING NO: 35-00-0237

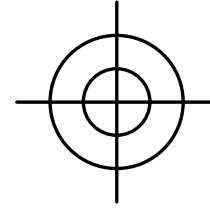
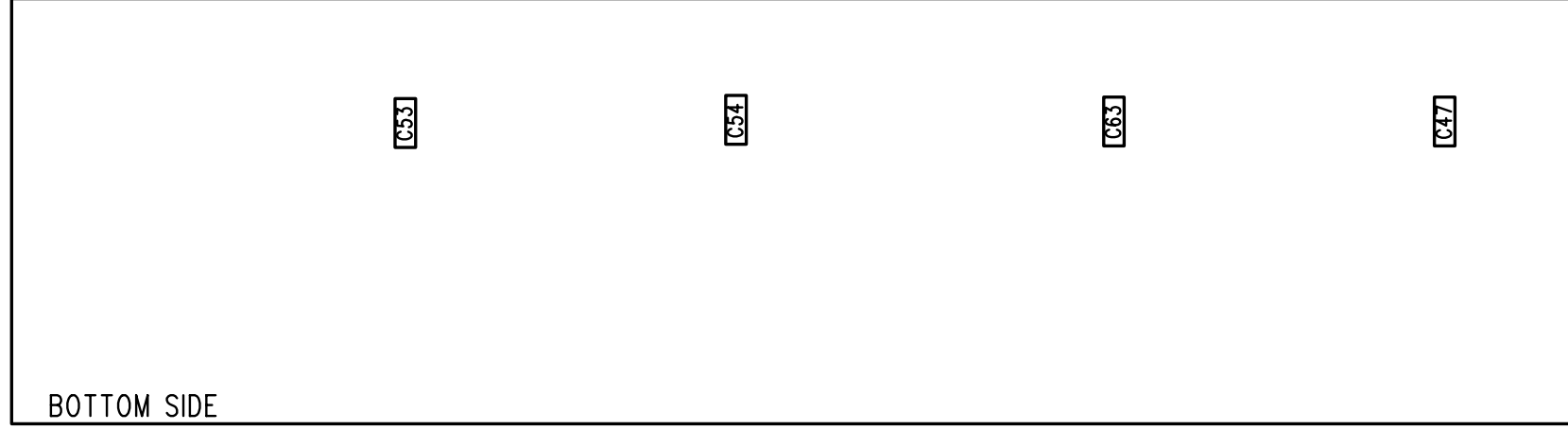
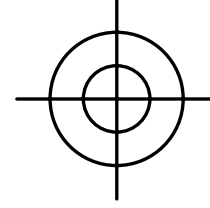
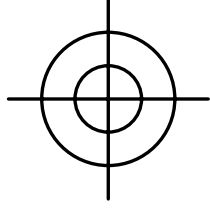

ASSEMBLY DRAWING BOTTOM

THE INFORMATION CONTAINED IN THIS DRAWING IS THE SOLE PROPERTY OF LINE & INC. ANY REPRODUCTION IN PART OR WHOLE WITHOUT THE WRITTEN PERMISSION OF LINE & INC. IS PROHIBITED

TITLE: SPEAKER OUTPUTS MODERN HEAD		DRAWING NO: 35-00-0537	
SCALE: NONE	REV: B	DATE: APRIL 7, 2003	
FILE: /ShortTone HD/PCBs/Speaker Out/Rev A/Modern HD Speaker Out Rev B.dcp			
PROGRAM: PADS POWER PCB V2.0		COMPANY: LINE & INC.	

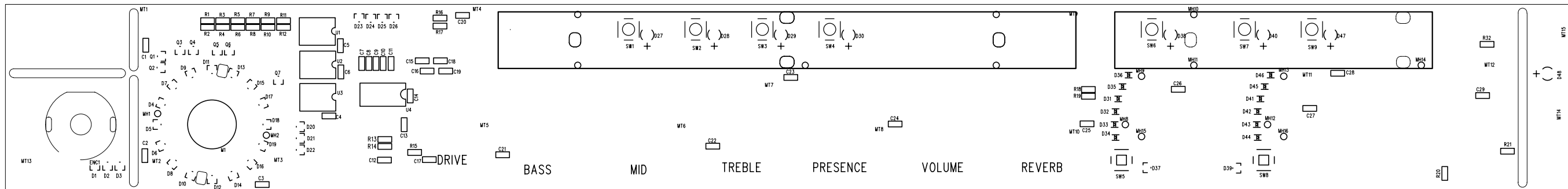

SILKSCREEN TOP

THE INFORMATION CONTAINED IN THIS DRAWING IS THE SOLE PROPERTY OF LINE 6 INC. ANY REPRODUCTION IN PART OR WHOLE WITHOUT THE WRITTEN PERMISSION OF LINE 6 INC. IS PROHIBITED

COMPANY:		 LINE 6 INC.	
PROGRAM: PADS POWER PCB V5.0			
FILE: FT3 Front Panel Rev C.pcb			
SCALE: NONE	REV: C	DATE: MARCH 21, 2003	
TITLE: FT3 FRONT PANEL		DRAWING NO: 35-00-0146	

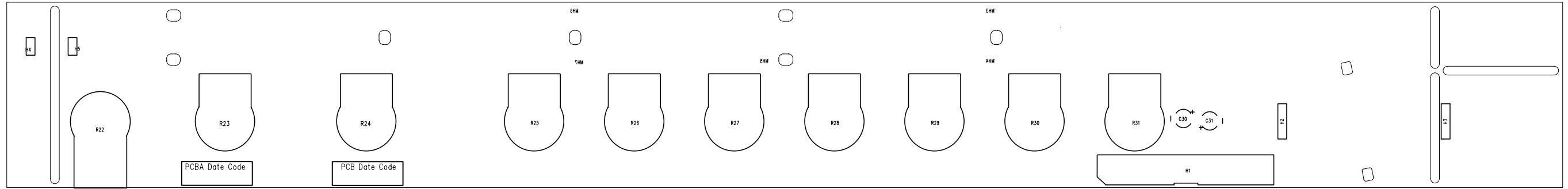

Place PCBA Date Code Here

ASSEMBLY BOTTOM

THE INFORMATION CONTAINED IN THIS DRAWING IS THE SOLE PROPERTY OF LINE 6 INC. ANY REPRODUCTION IN PART OR WHOLE WITHOUT THE WRITTEN PERMISSION OF LINE 6 INC. IS PROHIBITED.	
COMPANY: LINE 6 LINE 6 INC.	
PROGRAM: PADS POWER PCB V5.0	
FILE: FT3 Front Panel Rev C.pcb	
SCALE: NONE	REV: C
DATE: MARCH 21, 2003	
TITLE: FT3 FRONT PANEL	DRAWING NO: 35-00-0146

- DATE CODE REQUIREMENTS
- 1) Silkscreen date code for bare PCB fabrication in area marked on drawing.
 - 2) Place date code stamp or sticker for finished PCBA in area marked on drawing.

THE INFORMATION CONTAINED IN THIS DRAWING IS THE SOLE PROPERTY OF LINE 6 INC. ANY REPRODUCTION IN PART OR WHOLE WITHOUT THE WRITTEN PERMISSION OF LINE 6 INC. IS PROHIBITED.	
COMPANY: LINE 6 LINE 6 INC.	
PROGRAM: PADS POWER PCB V5.0	
FILE: FT3 Front Panel Rev C.pcb	
SCALE: NONE	REV: C
DATE: MARCH 21, 2003	
TITLE: FT3 FRONT PANEL	DRAWING NO: 35-00-0146

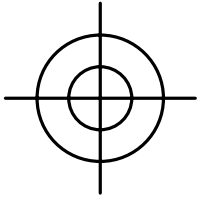
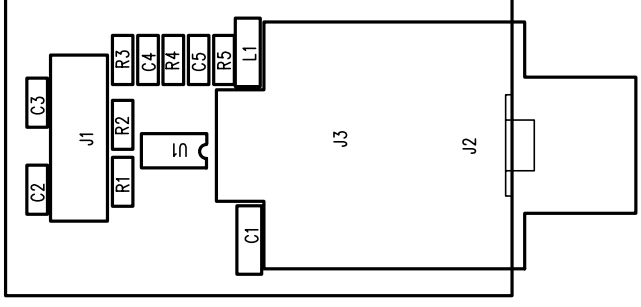
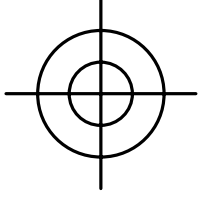
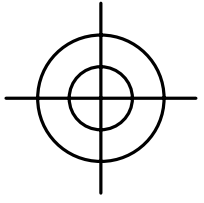

ASSEMBLY TOP

THE INFORMATION CONTAINED IN THIS DRAWING IS THE SOLE PROPERTY OF LINE 6 INC. ANY REPRODUCTION IN PART OR WHOLE WITHOUT THE WRITTEN PERMISSION OF LINE 6 INC. IS PROHIBITED

COMPANY:  LINE 6 INC.	
PROGRAM: PADS POWER PCB V4.0	
FILE: \SHARCTONE Product Family\DUJET 212 Combo\Electrical\PCB\GUITAR IN\REV C\DUJET GUITAR IN REV C.pcb	
SCALE: NONE	REV: C
DATE: AUGUST 27, 2002	
TITLE: SHARCTONE GUITAR INPUT	
DRAWING NO: 35-00-0169	

Items: 99-020-0515

I

Level	Seq	Component-Item	Component-Description							Qty-Per-Parent
=====										
Parent Item: 99-020-0515 HD 147 US										
1	10	21-37-1160	CABLE PWR UL/CSA SJT 8.2ft Blk EL-302 w/GND EL70	10	EA	.0	A	Y	N	1.000000
1	20	40-00-0021	MANUAL USERS HD147 FT3	10	EA	.0	A	Y	N	1.000000
1	30	40-00-0024	CHART PRESET HD147	10	EA	.0	A	Y	N	1.000000
1	40	40-00-0073	SHEET ACCESSORY DOMESTIC	10	EA	.0	A	Y	N	1.000000
1	50	40-10-0057	CARTON GIFT HD147 28.75x 12.5x 13.75, FOL, 275 D	10	EA	.0	A	Y	N	1.000000
1	60	40-10-0059	FOAM CORNER PE-LAMINATE 1.75" GRAY 5"-CUBE	10	EA	.0	A	Y	N	8.000000
1	70	40-20-0010	BAG PLASTIC 43"x38"x.004 CLEAR	10	EA	.0	A	Y	N	1.000000
1	80	40-20-0011	BAG PLASTIC 10 x 16 2 mil	10	EA	.0	A	Y	N	1.000000
1	90	55-00-0001	COVER AMPLIFIER POLISHING MODERN-HD FT3	10	EA	.0	A	Y	N	1.000000
1	100	59-00-0515	ASSY UNIT COMPLETE MODERN-HD FT3	10	EA	.0	A	Y	N	1.000000
2	20	21-30-0009-4	CBL DIL 10 PIN .100 PITCH 5.5-IN	10	EA	.0	A	Y	N	1.000000
2	30	21-34-0007-3	CBL SIL 4-COND 26AWG 2 x 127mm F-F RED	10	EA	.0	A	Y	N	1.000000
2	40	21-34-0008-2	CBL SIL 4-PINS .156 IN PITCH 10.0-IN	10	EA	.0	A	Y	N	1.000000
2	50	21-34-0014-2	CBL SIL 8-PINS .156 IN PITCH 13.0-IN	10	EA	.0	A	Y	N	1.000000
2	60	21-34-0015	CBL SIL 5-COND 26AWG 2mm x 151.0mm F-F Z-TYPE	10	EA	.0	A	Y	N	1.000000
2	70	21-34-0018-1	CBL SIL-4 3-COND 18AWG 7.5mm 229.0/203.0mm 1-BK/2-WH	10	EA	.0	A	Y	N	1.000000

Line 6
HD 147

2	80 21-34-0021-3 10.0-IN	CBL SIL 6-PIN .156 PITCH	10 EA	.0 A Y N	1.000000
2	90 21-34-0030	CBL ASSY SIL 2-CON 2.0 IN 2mm	10 EA	.0 A Y N	1.000000
2	100 21-34-9034-1 1.27mm 203.20mm	CBL DIL RIBBON 34-COND 28AWG	10 EA	.0 A Y N	1.000000
2	110 21-36-0265 WHT INSUL SOLID	CABLE SPKR 2 COND 24AWG 12.0"	10 EA	.0 A Y N	2.000000
2	120 24-03-0002 250V 6A 2-PIN CHASSIS MNT	Ref: 1. PWR Amp to SPK OUT SWITCH TOGGLE SPST ON-OFF	10 EA	2. LED PCBA to POWER SUPPLY J1 .0 A Y N	1.000000
2	130 24-21-1122	CAP SWITCH	10 EA	.0 A Y N	1.000000
2	140 30-00-0018	SCREW SELF-TAP 6-32 x .75 PFZ	10 EA	.0 A Y N	4.000000
2	150 30-00-0035 TOOTH CAPTIVE WASHER	SCREW 6-32 x 1" PPZ w/EXT	10 EA	.0 A Y N	1.000000
2	160 30-00-0039 BLACK	SCREW 10-32 x 1 IN PHIL-TRUSS	10 EA	.0 A Y N	8.000000
2	170 30-00-0040	SCREW 3-48 UNFx .25 FLT HD BLK	10 EA	.0 A Y N	2.000000
2	180 30-00-0041	SCREW 10-24 x .75 PHIL OVAL HD	10 EA	.0 A Y N	4.000000
2	185 30-00-0046 PPZ	SCREW SHEET METAL NO. 6 x 5/8	10 EA	.0 A Y N	2.000000
2	186 30-00-0047	Ref: Power Supply Heat Sink Spacers SCREW 10-32 x 5/8 IN PPZ	10 EA	.0 A Y N	4.000000
2	190 30-00-0375	SCREW 6-32 x .375 PPB	10 EA	.0 A Y N	15.000000
2	200 30-00-0607 PPZ STL	SCREW 6-32 x 7/16IN w/LK WASH	10 EA	.0 A Y N	38.000000
2	210 30-00-8375 SELF-TAP PPB	SCREW SHEET METAL #8 x.375"	10 EA	.0 A Y N	2.000000
2	230 30-00-4250 #4 x .250IN PPB	SCREW SHEET METAL SELF-TAP	10 EA	.0 A Y N	4.000000
2	235 30-03-0015	WASHER .750 OD x.560 IDx .045	10 EA	.0 A Y N	1.000000

Line 6
HD 147

2	240 30-06-0025	NUT .370 HEX 10-32 STL ZINC w/NYLON INSERT	10 EA	.0 A Y N	2.000000
2	250 30-06-0024	NUT .370 HEX 10-24 STL ZINC w/NYLON INSERT	10 EA	.0 A Y N	4.000000
2	260 30-06-0623	NUT HEX 6-32 w/CPTV STAR-WASHR	10 EA	.0 A Y N	2.000000
2	270 30-10-0001	PLUG HOLE FINISHING 3/8"ID x 1/2"OD STEEL NI-PLATED	10 EA	.0 A Y N	2.000000
2	290 30-12-8418	STANDOFF HEX .250 6-32 M-F 1IN AL	10 EA	.0 A Y N	9.000000
2	295 30-15-0004	SPACER .13THKx.630D NYLON	10 EA	.0 A Y N	1.000000
2	300 30-15-0012	SPACER .75 OD x .50 ID x .19HT NYLON	10 EA	.0 A Y N	1.000000
2	307 30-15-0014	SPACER .615 OD x .386 ID x .189 LG WHITE NYLON	10 EA	.0 A Y N	1.000000
2	310 30-15-0016	SPACER 6.4 x 3.7 x 15mm NYLON NATURAL	10 EA	.0 A Y N	1.000000
2	325 30-15-0019	SPACER HT SNK .75 ODx.830 HT NYLON 6/6 BLK	10 EA	.0 A Y N	2.000000
2	330 30-27-0049	LT PIPE SHARCTONE 1.4 OD x .47 HIGH CLR POLY MINITEXTURE	10 EA	.0 A Y N	1.000000
2	340 30-27-0060	LIGHTPIPES 6 PIN .38 x .719 LEXAN HIGHLY POLISHED	10 EA	.0 A Y N	2.000000
2	350 30-27-0061	BUTTON .315 DIA x .325 HIGH POLYOXMETHYLENE BLACK W/MATTE	10 EA	.0 A Y N	2.000000
2	360 30-33-0039-1	END CAP RIGHT 8.4x8.3x1.0 IN MDF BLK	10 EA	.0 A Y N	1.000000
2	370 30-33-0039-2	END CAP LEFT 8.4x8.3x1.0 IN MDF BLK	10 EA	.0 A Y N	1.000000
2	394 30-45-0007	KNOB SPLINE .77DIA x .76 METAL w/INDICATOR CHROME	10 EA	.0 A Y N	10.000000
2	396 30-45-0008	KNOB SPLINE .77DIA x .76 METAL CHROME	10 EA	.0 A Y N	1.000000
2	400 30-51-0070	SHIELD CHASSIS 23.44x 8x .5IN STEEL-EG	10 EA	.0 A Y N	1.000000
2	410 30-51-0113	LENS JEWEL D.610 x H.654IN METAL BASE w/NUT CLEAR	10 EA	.0 A Y N	1.000000
2	420 30-51-0122	CHASSIS BASE 8.4x 23.5 x 1.6IN	CRS CHROME-PLATED		1.000000

Line 6
HD 147

2	430 30-51-0125	CHASSIS TOP 23.50x8.35x4.75 IN CRS CHROME PLATED	10 EA	.0	A	Y	N	1.000000
2	440 30-51-0126	PANEL I/O 11.35 x 5.77 x .30IN CRS BLK	10 EA	.0	A	Y	N	1.000000
2	450 30-51-0127	PANEL AC-RECEPT 5.77 x 4.10IN CRS BLACK	10 EA	.0	A	Y	N	1.000000
2	460 30-51-0137	OVERLAY 23.5x3.75x.02 AL	10 EA	.0	A	Y	N	1.000000
2	470 30-57-0001	HANDLE HD147	10 EA	.0	A	Y	N	1.000000
2	490 30-60-0005	LOGO LINE 6 MED 139.70x28.63mm BRUSHED/BLK FINISH AL	10 EA	.0	A	Y	N	1.000000
2	500 30-75-0008	FOOT RUBBER 1.50" I.D. x .75"H BLACK	10 EA	.0	A	Y	N	4.000000
2	510 30-75-9600	GROMMET RUBBER 7/16-D x 1/16-GRV x 9/16IN GRV-DIA BLK	10 EA	.0	A	Y	N	1.000000
2	540 50-00-0169	PCBA INPUT GUITAR HD147	10 EA	.0	A	Y	N	1.000000
3	10 01-00-0102	RES 1K 5% 0805	10 EA	.0	A	Y	N	1.000000
3	20 01-00-0105	Ref: R4 RES 1M 5% 0805	10 EA	.0	A	Y	N	1.000000
3	30 01-24-1002	Ref: R3 RES 10.0K 1% 0805	10 EA	.0	A	Y	N	1.000000
3	40 01-24-4991	Ref: R1 RES 4.99K 1% 0805	10 EA	.0	A	Y	N	1.000000
3	50 01-24-8870	Ref: R2 RES 887R 1% 0805	10 EA	.0	A	Y	N	1.000000
3	60 03-46-0104	Ref: R5 CAP X7R 0.1uF 50V 20% 1206 Ref: C1	10 EA	.0	A	Y	N	1.000000

Line 6
HD 147

3	70 03-50-0470	CAP NPO 47pF 50V 10% 0805	10 EA	.0 A Y N	1.000000
3	80 03-52-0473	Ref: C4 CAP X7R 47nF 50V 20% 0805	10 EA	.0 A Y N	3.000000
3	90 11-10-0601	Ref: C2-3,C5 FERRITE BEAD 600R @100MHZ 1206	10 EA	.0 A Y N	1.000000
3	100 12-54-0134 SO-8	Ref: L1 IC OP AMP - OPA134UA SM	10 EA	.0 A Y N	1.000000
3	110 21-00-6617 HORIZ TH	Ref: U1 JACK 1/4" TRS 6-PIN PCB MT W/CHROME HRDWARE	10 EA	.0 A Y N	1.000000
3	120 21-20-0205 MALE SHRD	Ref: J3 HDR PCB MT SIL 5-PIN x 2mm VERT MT TH	10 EA	.0 A Y N	1.000000
3	130 30-18-3030	Ref: J1 CLIP GND PCB .30x.30x.07	10 EA	.0 A Y N	1.000000
		Ref: J2			
2	550 50-00-0204	PCBA MAIN HD47	10 EA	.0 A Y N	1.000000
3	10 01-00-0000	RES 0R 5% 0805	0 EA	.0 A Y N	1.000000
3	15 01-00-0155	Ref: R66 RES 1.5M 5% 0805	0 EA	.0 A Y N	1.000000
3	20 01-24-1000	Ref: R89 RES 100R 1% 0805	0 EA	.0 A Y N	3.000000
3	25 01-24-1001	Ref: R64,R67,R108 RES 1.00K 1% 0805	0 EA	.0 A Y N	19.000000
3	30 01-24-1002	Ref: R8,R21,R54-56,R86,R92,R95-96,R113,R115,R120,R130,R144-145, R153-154,R157-158 RES 10.0K 1% 0805	0 EA	.0 A Y N	27.000000
		Ref: R10,R23,R51-52,R59-60,R68,R71,R73-74,R76-77,R80,R83,R103, R110-111,R116-118,R128,R131-132,R134,R136,R141,R147			

Line 6
HD 147

3	35 01-24-1003	RES 100K 1% 0805	0 EA	.0	A	Y	N	11.000000
		Ref: R97-98,R135,R137,R165-166,R168-172						
3	40 01-24-1004	RES 1.00M 1% 0805	0 EA	.0	A	Y	N	6.000000
		Ref: R72,R75,R85,R88,R91,R94						
3	45 01-24-1102	RES 11.0K 1% 0805	0 EA	.0	A	Y	N	4.000000
		Ref: R99-100,R106-107						
3	50 01-24-1241	RES 1.24K 1% 0805	0 EA	.0	A	Y	N	2.000000
		Ref: R4,R9						
3	55 01-24-15R0	RES 15R 1% 0805	0 EA	.0	A	Y	N	2.000000
		Ref: R123,R142						
3	60 01-24-1822	RES 18.2K 1% 0805	0 EA	.0	A		N	4.000000
		Ref: R2-3,R6,R13						
3	65 01-24-2000	RES 200R 1% 0805	0 EA	.0	A		N	1.000000
		Ref: R150						
3	70 01-24-2001	RES 2.00K 1% 0805	0 EA	.0	A	Y	N	16.000000
		Ref: R7,R15,R19,R24-26,R32,R34-38,R44-45,R47-48						
3	75 01-24-2002	RES 20.0K 1% 0805	0 EA	.0	A	Y	N	2.000000
		Ref: R133,R149						
3	80 01-24-2210	RES 221R 1% 0805	0 EA	.0	A	Y	N	3.000000
		Ref: R90,R101-102						
3	85 01-24-2211	RES 2.21K 1% 0805	0 EA	.0	A	Y	N	2.000000
		Ref: R61,R62						
3	90 01-24-22R1	RES 22.1R 1% 0805	0 EA	.0	A	Y	N	2.000000
		Ref: R27,R39						
3	95 01-24-2741	RES 2.74K 1% 0805	0 EA	.0	A	Y	N	2.000000
		Ref: R17-18						
3	100 01-24-2801	RES 2.80K 1% 0805	0 EA	.0	A	Y	N	2.000000
		Ref: R79,R82						
3	105 01-24-3011	RES 3.01K 1% 0805	0 EA	.0	A	Y	N	6.000000

Line 6
HD 147

3	110 01-24-3651	Ref: R20,R87,R93,R112,R114,R148 RES 3.65K 1% 0805	0 EA	.0	A	Y	N	2.000000
3	115 01-24-4321	Ref: R57-58 RES 4.32K 1% 0805	0 EA	.0	A	Y	N	1.000000
3	120 01-24-4750	Ref: R33 RES 475R 1% 0805	0 EA	.0	A	Y	N	3.000000
3	125 01-24-4751	Ref: R104-105,R109 RES 4.75K 1% 0805	0 EA	.0	A	Y	N	10.000000
3	130 01-24-47R5	Ref: R53,R69,R140,R146,R151-152,R159-162 RES 47.5R 1% 0805	0 EA	.0	A	Y	N	8.000000
3	135 01-24-5110	Ref: R119,R124-126,R129,R138-139,R143 RES 511R 1% 0805	0 EA	.0	A	Y	N	1.000000
3	140 01-24-5R11	Ref: R12 RES 5.11R 1% 0805	0 EA	.0	A	Y	N	4.000000
3	145 01-24-6041	Ref: R43,R46,R163-164 RES 6.04K 1% 0805	0 EA	.0	A	Y	N	1.000000
3	150 01-24-6650	Ref: R22 RES 665R 1% 0805	0 EA	.0	A	Y	N	2.000000
3	155 01-24-6810	Ref: R63,R65 RES 681R 1% 0805	0 EA	.0	A	Y	N	4.000000
3	160 01-24-7500	Ref: R1,R16,R40,R49 RES 750R 1% 0805	0 EA	.0	A	Y	N	2.000000
3	165 01-24-7501	Ref: R78,R81 RES 7.50K1% 0805	0 EA	.0	A	Y	N	1.000000
3	170 01-24-8253	Ref: R5 RES 825K 1% 0805	0 EA	.0	A	Y	N	1.000000
3	175 01-24-8871	Ref: R84 RES 8.87K 1% 0805	0 EA	.0	A	Y	N	8.000000

Ref: R11,R14,R28-31,R41-42

Line 6
HD 147

3	180 01-48-9103	POT STEREO 10KA AUDIO TAPER HORIZ MT 25mm RND PLASTIC	0 EA	.0	A Y N	1.000000
		Ref: POT1				
3	185 03-10-6108	CAP ELEC 1000uF 6.3V 20% RADIAL 8/11.5/5	0 EA	.0	A Y N	2.000000
		Ref: C18,C24				
3	190 03-12-0337	CAP ELEC 330uF 16V 20% RADIAL 8/11.5/5	0 EA	.0	A Y N	2.000000
		Ref: C48,C79				
3	195 03-14-0107	CAP ELEC 100uF 25V 20% RADIAL 6.3/11.2/5	0 EA	.0	A Y N	2.000000
		Ref: C38,C44				
3	200 03-18-0105	CAP ELEC 1uF 50V 20% RADIAL 5/11/5	0 EA	.0	A Y N	14.000000
		Ref: C3-4,C8-9,C16-17,C19,C40,C46-47,C63-64,C73-74				
3	205 03-18-0106	CAP ELEC 10uF 50V 20% RADIAL 5/11/5	0 EA	.0	A Y N	12.000000
		Ref: C15,C28,C57-58,C62,C66,C71-72,C76,C78,C82,C88				
3	210 03-18-0474	CAP ELEC 0.47uF 50V 20% RADIAL 5/11/5	0 EA	.0	A Y N	1.000000
		Ref: C59				
3	215 03-50-0102	CAP NPO 1nF 50V 5% 0805	0 EA	.0	A Y N	4.000000
		Ref: C70,C106,C110,C118				
3	220 03-50-0272	CAP NPO 2.7nF 50V 5% 0805	0 EA	.0	A Y N	4.000000
		Ref: C7,C27,C31-32				
3	225 03-50-0391	CAP NPO 390pF 50v 5% 0805	0 EA	.0	A Y N	8.000000
		Ref: C2,C6,C10,C12-14,C20,C23				
3	230 03-52-0101	CAP X7R 100pF 50V 20% 0805	0 EA	.0	A Y N	2.000000
		Ref: C132,C138				
3	235 03-52-0102	CAP X7R 1nF 50V 20% 0805	0 EA	.0	A Y N	15.000000
		Ref: C34,C43,C96-97,C99,C103-105,C114,C121,C126,C148-149,C154, C158				
3	240 03-52-0104	CAP X7R 0.1uF 50V 20% 0805	0 EA	.0	A Y N	12.000000
		Ref: C54,C56,C95,C100-101,C117,C120,C125,C131,C137,C147,C152				
3	245 03-52-0221	CAP X7R 220pF 50V 20% 0805	0 EA	.0	A Y N	6.000000
		Ref: C1,C5,C49-50,C77,C81				

3	250 03-52-0222	CAP X7R 2.2nF 50V 20% 0805	0 EA	.0	A Y N	2.000000
3	255 03-52-0473	Ref: C26,C36 CAP X7R 47nF 50V 20% 0805	0 EA	.0	A Y N	63.000000
3	260 06-20-0099	Ref: C11,C21-22,C25,C29-30,C33,C35,C37,C39,C41-42,C45,C51-53,C55, C60-61,C65,C67-69,C75,C80,C83,86-87,89-94,102,C115,C122-124, C127-130,C133-136,C139-146,C150-151,C153,C155-157,C159-160 DIODE GEN PUR DUAL 70V 215mA 6nS SOT-23 SM BAV99	0 EA	.0	A Y N	8.000000
3	265 06-34-0016	Ref: D1-3,D5-6,D21-23 DIODE SWITCHING 75V 200mA 6nS SOT-23 SM BAS16LT1	0 EA	.0	A Y N	15.000000
3	270 09-10-4401	Ref: D4,D7-20 TRANS NPN SMALL-SIGNAL MBT4401 SOT-23 SM	0 EA	.0	A Y N	3.000000
3	275 09-10-4403	Ref: Q1,Q3-4 TRANS PNP SMALL-SIGNAL MBT4403 SOT-23 SM	0 EA	.0	A Y N	1.000000
3	280 11-00-3000	Ref: Q2 CRYSTAL OSCILLATOR 30MHz 3.3V DIP4 TH	0 EA	.0	A Y N	1.000000
3	285 11-10-0501	Ref: Y1 FERRITE BEAD 500R @100MHZ 2.5A 1206 SM	0 EA	.0	A Y N	2.000000
3	290 11-10-0601	Ref: L5-6 FERRITE BEAD 600R @100MHZ 1206	0 EA	.0	A Y N	26.000000
3	295 12-02-1086	Ref: L1-4,L7-28 IC REG +3.3V TO-220 TH LM1086	0 EA	.0	A Y N	1.000000
3	300 12-02-7805	Ref: U26 IC REG +5v 1.5 Amp TH	0 EA	.0	A Y N	2.000000
3	305 12-02-7815	Ref: U8,U27 IC REG +15V 1AMP TO-220 TH	0 EA	.0	A Y N	1.000000
3	310 12-02-7915	Ref: U29 IC REG -15V 1AMP TO-220 TH 7915	0 EA	.0	A Y N	1.000000
3	315 12-54-0082	Ref: U31 IC OP AMP DUAL TL082CD SO-8 SM Ref: U2-3,U33	0 EA	.0	A Y N	3.000000

3	320 12-54-0084	IC OP AMP QUAD TL084CD SM	0 EA	.0	A	Y	N	6.000000
		Ref: U1,U7,U17,U28,U30,U32						
3	325 12-54-5538	IC OP-AMP DUAL LO NOISE NE5532AD8 SM SO-8	0 EA	.0	A	Y	N	1.000000
		Ref: U4						
3	330 12-62-4053	IC SWITCH-ANALOG TRIPLE 2-CHAN TSSOP-16 SM CD4053BPW	0 EA	.0	A	Y	N	2.000000
		Ref: U9,U13						
3	335 12-64-4528	IC CONVERTER 24B 48/96KHz AUDIO CODEC SM AK4528	0 EA	.0	A	Y	N	2.000000
		Ref: U5-6						
3	340 15-40-6138	IC 6N138 OPTO-ISOLATOR DIP-8 TH	0 EA	.0	A	Y	N	1.000000
		Ref: U24						
3	345 15-64-0014	IC 74HCT14 HEX INVERTER 6 SM	0 EA	.0	A	Y	N	1.000000
		Ref: U21						
3	350 15-65-0014	IC 74LCX14 LOW VOLTAGE CMOS INV HEX SCHMITT TRIGGER SM	0 EA	.0	A	Y	N	1.000000
		Ref: U19						
3	355 15-67-0179	IC RS-485 LOW PWR DIFF TRANSCEIVER SN75LBC179 SO-8 SM	0 EA	.0	A	Y	N	1.000000
		Ref: U25						
3	360 15-70-1610	IC DRAM 1M X 16 SDRAM HY57V161610DTC-7 SM	0 EA	.0	A	Y	N	2.000000
		Ref: U11-12						
3	365 15-86-1065	IC DSP SHARC ADSP-21065LKS-240 MQFP208 SM	0 EA	.0	A	Y	N	1.000000
		Ref: U14						
3	370 15-92-5810	IC RESET 5V 5% ACTIVE-HI SOT-23 SM LM810	0 EA	.0	A	Y	N	1.000000
		Ref: U18						
3	375 21-00-6616	JACK 1/4" TRS 6-PIN PCB MT HORIZ TH	0 EA	.0	A	Y	N	5.000000
		Ref: J3-6,J9						
3	380 21-04-5075	JACK DIN 5-PIN FEMALE MIDI PCB-MNT RT-ANG LN 05075	0 EA	.0	A	Y	N	2.000000
		Ref: P1-2						
3	385 21-08-0013	JACK XLR MALE PCB MNT RT ANG TH NEUTRIK-NC3MAH	0 EA	.0	A	Y	N	2.000000
		Ref: J1-2						

3	390 21-16-0045	JACK RJ-45 8-PIN FEMALE PCB-MNT RT-ANG	0 EA	.0	A	Y	N	1.000000
		Ref: J7						
3	395 21-18-0002	TERMINAL SCREW PCB MOUNT RT ANGLE SNAP-IN TH	0 EA	.0	A	Y	N	1.000000
		Ref: BR2						
3	400 21-20-0205	HDR PCB MT SIL 5-PIN x 2mm MALE SHRD VERT MT TH	0 EA	.0	A	Y	N	1.000000
		Ref: H1						
3	405 21-20-1033	HDR PCB MT DIL 34-PIN 2x17x2mm MALE SHRD VERT MT TH	0 EA	.0	A	Y	N	1.000000
		Ref: H4						
3	410 21-20-1568	HDR PCB MT SIL 8-PIN X .156 MALE VERT-MNT FRIC-LOCK	0 EA	.0	A	Y	N	1.000000
		Ref: H6						
3	415 21-20-2010	HDR PCB MT DIL 10-PIN 2x5x100 MALE SHRD VERT	0 EA	.0	A	Y	N	2.000000
		Ref: H5,H7						
3	420 21-44-0044	SOCKET 44 PIN PLCC - .050 LOW PROFILE SMT	0 EA	.0	A	Y	N	1.000000
		Ref: S1						
3	425 24-09-0222	SWITCH SLIDE DPDT	0 EA	.0	A	Y	N	1.000000
		Ref: SW1						
3	430 30-00-0607	SCREW 6-32 x 7/16IN w/LK WASH PPZ STL	0 EA	.0	A	Y	N	2.000000
		Ref: U29,U31						
3	435 30-06-0623	NUT HEX 6-32 w/CPTV STAR-WASHR	0 EA	.0	A	Y	N	2.000000
		Ref: U29,U31						
3	440 30-18-3030	CLIP GND PCB .30x.30x.07	0 EA	.0	A	Y	N	7.000000
		Ref: GF1-6,GF8						
3	445 30-51-0029	HEATSINK AL BLK ANODIZED	0 EA	.0	A	Y	N	1.000000
		Ref: P3						
3	450 30-51-0057	HEAT SINK, BLACK ANODIZED AL, WAKEFIELD #287-1AB	0 EA	.0	A	Y	N	1.000000
		Ref: P4						
3	460 45-01-0001	IC PROGRAMMED MPU V1.01 c/s = CFA3 DUET	0 EA	.0	A	Y	N	1.000000
		Ref: U16						
4	10 15-84-8752	IC MCU 87C51MB OTP w/2K byte SRAM and 64K ROM PLCC44	10 EA	.0	A	Y	N	1.000000

3	470 45-02-0006	IC PROGRAMMED FLASH v1.01 c/s=05AC161F MODERN-HD	0 EA	.0	A	Y	N	1.000000
		Ref: U10						
4	10 15-78-0000	IC FLASH 4Meg 512Kx8/256x16 TSOP-48 SM AM29LV400	0 EA	.0	A	Y	N	1.000000
3	475 45-06-0001	IC PROGRAMMED PLD HD147 REV B	0 EA	.0	A	Y	N	1.000000
		Ref: U15						
4	10 15-96-0000	IC PLD 64 MACROCELL/64IO TQFP100 SM M4A3-64/64-10VC	10 EA	.0	A	Y	N	1.000000
2	560 50-00-0238	ASSY CAP SWITCH w/ARTWORK CLASSIC FT3	10 EA	.0	A	Y	N	1.000000
3	10 30-27-0066	SWITCH CAP 6.4x.63x.55	0 EA	.0	A		N	.0000 1.000000
2	570 50-00-4001	PCBA LINE FILTER	10 EA	.0	A	Y	N	1.000000
3	10 01-12-0154	RES CARBON FILM 150K 1/4W 5% TH	0 EA	.0	A	Y	N	2.000000
		Ref: R1-R2.						
3	20 01-70-0516	THERMISTOR INRUSH 0.5R@16A 5/22/7.8 TH	0 EA	.0	A	Y	N	1.000000
		Ref: RT1.						
3	30 03-00-1102	CAP Y-CAP 1nF 250VAC 20% CER DISC 8D/7/7.5	0 EA	.0	A	Y	N	2.000000
		Ref: C3-C4.						
3	40 03-41-0224	CAP X-CAP 0.22uF 275VAC 20% POLYPROPYLENE 18/9.5/17.5/15	0 EA	.0	A	Y	N	1.000000
		Ref: C1.						
3	50 11-10-3501	INDUCTOR COMMON MODE LINE FILTER ICE LF-35040-0044	0 EA	.0	A	Y	N	2.000000
		Ref: L1-2						
3	60 21-14-8301	JACK IEC ANGLED 10A IEC320 POWER-COMPONENTS 83011172	0 EA	.0	A	Y	N	1.000000
		Ref: J1.						
3	65 21-20-2075	HDR PCB MT SIL 2-PIN X 7.5mm MALE VERT MT FRIC-LOCK TH	0 EA	.0	A	Y	N	1.000000
		Ref: J2						
3	90 21-34-1806	CBL S-T/EYE 1-COND 126mm STRND 18AWG GRN/YL EARTHING	0 EA	.0	A	Y	N	1.000000
		Ref: Solder to through hole clip on pn# 21-14-8301 at M4						
3	100 21-48-9521	CLIP FUSE HOLDER	0 EA	.0	A	Y	N	2.000000
		Ref: F,F1.						

3	105 24-19-8250	FUSE 8A/250V 5X20mm FRN F LITTLEFUSE 217 008 or equiv	0 EA	.0	A	Y	N	1.000000
		Ref: f,f1(install into fuse clip holders,pn# 21-48-9521).						
2	580 50-00-9102	ASSY FINAL POWER AMP HD147	10 EA	.0	A	Y	N	1.000000
3	10 30-00-0010	SCREW 8-32 x 9/16 SKT-CAP S-STL	10 EA	.0	A	Y	N	10.000000
3	20 30-03-0002	WASHER #8 .293 x.174x .040 STEEL	10 EA	.0	A	Y	N	12.000000
3	30 30-06-0007	NUT .344 HEX 8-32 STEEL ZINC	10 EA	.0	A	Y	N	10.000000
3	40 30-51-0059-2	HEATSINK 6.0 IN LG AL ALY	10 EA	.0	A	Y	N	1.000000
3	50 30-51-0073	CLAMP HEATSINK TO-220 1.3x.45x.35" CR STEEL 1018	10 EA	.0	A	Y	N	10.000000
3	60 30-63-4001	PAD THERMAL TO-247 BERG-400AC-7-102	10 EA	.0	A	Y	N	8.000000
3	70 30-63-4005	PAD THERMAL TO-220 BERG-400-7-54	10 EA	.0	A	Y	N	4.000000
3	80 30-63-5050	GAP-PAD VO-SOFT .125"THK x .50 " x .50"	10 EA	.0	A	Y	N	1.000000
3	90 50-00-0205	PCBA POWER AMP HD147	10 EA	.0	A	Y	N	1.000000
4	10 01-00-0334	RES 330K 5% 0805	0 EA	.0	A	Y	N	3.000000
		Ref: R7,R78,R84						
4	20 01-00-0393	RES 39K 5% 0805	0 EA	.0	A	Y	N	4.000000
		Ref: R2,R25,R145-146						
4	30 01-00-05R1	RES 5.1R 5% 0805	0 EA	.0	A	Y	N	8.000000
		Ref: R27-28,R47-48,R59,R95,R115,R136						
4	60 01-20-02R2	RES METAL OXIDE 2.2R 2W 5% TH S/B 01-22-02R2	0 EA	.0	A	Y	N	2.000000
		Ref: R23,R69						
4	70 01-20-0R22	RES METAL OXIDE 0.22R 2W 5% TH S/B 01-22-0R22	0 EA	.0	A	Y	N	8.000000
		Ref: R19,R21,R30,R54,R94,R104,R106,R138						

Line 6
HD 147

4	80 01-24-1001	RES 1.00K 1% 0805	0 EA	.0	A Y N		4.000000
4	90 01-24-1002	Ref: R36,R109,R119,R128 RES 10.0K 1% 0805	0 EA	.0	A Y N		15.000000
4	100 01-24-1003	Ref: R49,R51-52,R62,R64,R67,R70,R73,R86,R97,R101,R108,R111, R142,R144 RES 100K 1% 0805	0 EA	.0	A Y N		20.000000
4	110 01-24-1004	Ref: R8,R13,R15,R26,R33,R35,R50,R55,R76-77,R79,R85,R130,R134, R143,R159-161,R162,R163 RES 1.00M 1% 0805	0 EA	.0	A Y N		9.000000
4	120 01-24-1102	Ref: R31,R34,R74,R99,R121,R129,R149,R153,R155 RES 11.0K 1% 0805	0 EA	.0	A Y N		2.000000
4	130 01-24-1242	Ref: R6,R83 RES 12.4K 1% 0805	0 EA	.0	A Y N		4.000000
4	140 01-24-1500	Ref: R22,R24,R88,R152 RES 150R 1% 0805	0 EA	.0	A Y N		15.000000
4	150 01-24-1502	Ref: R3,R5,R12,R16,R18,R38,R44,R46,R96,R103,R105,R116-117,R123 R127 RES 15.0K 1% 0805	0 EA	.0	A Y N		2.000000
4	160 01-24-2001	Ref: R39,R118 RES 2.00K 1% 0805	0 EA	.0	A Y N		4.000000
4	170 01-24-2491	Ref: R60,R65,R148,R154 RES 2.49K 1% 0805	0 EA	.0	A Y N	.0000	4.000000
4	180 01-24-2492	Ref: R87,R147,R150-151 RES 24.9K 1% 0805	0 EA	.0	A Y N		2.000000
4	190 01-24-2493	Ref: R57,R114 RES 249K 1% 0805	0 EA	.0	A Y N		1.000000
4	200 01-24-2742	Ref: R63 RES 27.4K 1% 0805	0 EA	.0	A Y N		8.000000
		Ref: R9,R17,R20,R53,R75,R93,R110,R139					

Line 6
HD 147

4	210 01-24-3161	RES 3.16K 1% 0805	0 EA	.0	A Y N		2.000000
		Ref: R40,R126					
4	220 01-24-3482	RES 34.8K 1% 0805	0 EA	.0	A Y N		2.000000
		Ref: R89,R141					
4	230 01-24-4750	RES 475R 1% 0805	0 EA	.0	A Y N		15.000000
		Ref: R1,R4,R10-11,R41-42,R58,R61,R92,R102,R107,R112,R137,R157-158					
4	240 01-24-4751	RES 4.75K 1% 0805	0 EA	.0	A Y N		12.000000
		Ref: R37,R71,R81,R98,R100,R120,R122,R124-125,R132-133,R135					
4	250 01-24-4752	RES 47.5K 1% 0805	0 EA	.0	A Y N		2.000000
		Ref: R32,R131					
4	260 01-24-4753	RES 475K 1% 0805	0 EA	.0	A Y N		1.000000
		Ref: R56					
4	270 01-24-4992	RES 49.9K 1% 0805	0 EA	.0	A Y N		2.000000
		Ref: R43,R90					
4	280 01-24-6041	RES 6.04K 1% 0805	0 EA	.0	A Y N		3.000000
		Ref: R14,R72,R91					
4	290 01-24-6492	RES 64.9K 1% 0805	0 EA	.0	A Y N		1.000000
		Ref: R66					
4	300 01-24-8251	RES 8.25K 1% 0805	0 EA	.0	A Y N		1.000000
		Ref: R80					
4	310 01-24-8252	RES 82.5K 1% 0805	0 EA	.0	A Y N	.0000	2.000000
		Ref: R164,R165					
4	320 01-24-8871	RES 8.87K 1% 0805	0 EA	.0	A Y N		2.000000
		Ref: R113,R140					
4	330 01-24-9092	RES 90.9K 1% 0805	0 EA	.0	A Y N		4.000000
		Ref: R29,R45,R68,R82					
4	340 01-70-0080	THERMISTOR 80C PTC TH 100/300/200	0 EA	.0	A Y N		1.000000
		Ref: RT1					
4	350 03-12-0107	CAP ELEC 100uF 16V 20% RADIAL	Ref: C18,C22,C25				3.000000

4	360 03-18-0105 5/11/5	CAP ELEC 1uF 50V 20% RADIAL	0 EA	.0 A Y N		4.000000
		Ref: C54-57				
4	370 03-18-0227 RADIAL 10/12.5/5	CAP ELEC 220uF 50V 20%	0 EA	.0 A Y N		1.000000
		Ref: C8				
4	380 03-18-0336 5/11/5	CAP ELEC 33uF 50V 20% RADIAL	0 EA	.0 A Y N		2.000000
		Ref: C1,C3				
4	390 03-18-0474 5/11/5	CAP ELEC 0.47uF 50V 20% RADIAL	0 EA	.0 A Y N		1.000000
		Ref: C9				
4	400 03-22-0476 10/15/5	CAP ELEC 47uF 100V 20% RADIAL	0 EA	.0 A Y N		4.000000
		Ref: C38-41				
4	410 03-24-0334 TH 12.5/6.5/11.5/7.5	CAP 0.33uF 250V 5% FILM-POLY	0 EA	.0 A Y N		2.000000
		Ref: C6,C11				
4	420 03-32-0473 7.9/4.5/7.4/5	CAP POLYESTER 47nF 250V 10% TH	0 EA	.0 A Y N		2.000000
		Ref: C42-43				
4	440 03-50-0152	CAP NPO 1.5nF 50V 20% 0805	0 EA	.0 A Y N	.0000	2.000000
		Ref: C12,C23				
4	450 03-52-0101	CAP X7R 100pF 50V 20% 0805	0 EA	.0 A Y N		2.000000
		Ref: C2,C7				
4	460 03-52-0222	CAP X7R 2.2nF 50V 20% 0805	0 EA	.0 A Y N		1.000000
		Ref: C16				
4	470 03-52-0223	CAP X7R 22nF 50V 10% 0805 SM	0 EA	.0 A Y N		4.000000
		Ref: C19,C36,C45-46				
4	480 03-52-0470	CAP X7R 47pF 50V 20% 0805	0 EA	.0 A Y N		8.000000
		Ref: C4-5,C14-15,C47-50				
4	490 03-52-0473	CAP X7R 47nF 50V 20% 0805	0 EA	.0 A Y N		16.000000
		Ref: C10,C17,C20-21,C24,C27-28,C32-35,C37,C44,C51-53				
4	500 03-52-1220	CAP X7R 22pF 200V 20% 0805	0 EA	.0 A Y N		2.000000
		Ref: C13,c26				

4	510 06-12-1045	DIODE SCHOTTKY 45V 10A TO-220AC TH MBR1045	0 EA	.0	A	Y	N	2.000000
		Ref: D8,D12						
4	520 06-28-8412	DIODE ZENER 12V 5% 350mW SOT-23 SM BZX84C12	0 EA	.0	A	Y	N	3.000000
		Ref: D6-7,D17						
4	530 06-28-8418	DIODE ZENER 18V 5% 350mW SOT-23 SM BZX84C18	0 EA	.0	A	Y	N	1.000000
		Ref: D21						
4	540 06-28-8439	DIODE ZENER 3.9V 5% 350mW SOT-23 SM BZX84C3V9	0 EA	.0	A	Y	N	1.000000
		Ref: D10						
4	550 06-28-8468	DIODE ZENER 6.8V 5% 350mW SOT-23 SM BZX84C6V8	0 EA	.0	A	Y	N	8.000000
		Ref: D1,D13-14,D16,D19-20,D22-23						
4	560 06-34-0016	DIODE SWITCHING 75V 200mA 6nS SOT-23 SM BAS16LT1	0 EA	.0	A	Y	N	11.000000
		Ref: D2-5,D9,D11,D15,D18,D24-25,D34						
4	570 09-00-4403	TRANS PNP SMALL-SIGNAL 2N4403 TH	0 EA	.0	A	Y	N	1.000000
		Ref: Q35						
4	580 09-00-5551	TRANS NPN SMALL-SIGNAL 2N5551 TH	0 EA	.0	A	Y	N	6.000000
		Ref: Q21,Q23,Q34,Q38,Q50-51						
4	590 09-06-0006	TRANS POWER-MOSFET N-CHAN MTP50N06V TH TO-220	0 EA	.0	A	Y	N	2.000000
		Ref: Q2,Q12						
4	600 09-06-0251	TRANS MOSFET N-CHAN 200V .075R TO-247 TH IRFP250N	0 EA	.0	A	Y	N	8.000000
		Ref: Q9,Q10,Q13-14,Q46-49						
4	610 09-10-0042	TRANS NPN POWER 300V 200mA SOT-23 SM MMBTA42	0 EA	.0	A	Y	N	3.000000
		Ref: Q3,Q37,Q42						
4	620 09-10-0092	TRANS SMALL-SIGNAL PMBTA92 SOT-23 SMD	0 EA	.0	A	Y	N	5.000000
		Ref: Q1,Q24,Q27,Q41,Q43						
4	630 09-10-4401	TRANS NPN SMALL-SIGNAL MBT4401 SOT-23 SM	0 EA	.0	A	Y	N	12.000000
		Ref: Q4-5,Q11,Q16,Q18,Q26,Q28-29,Q32,Q39-40,Q45						
4	640 09-10-4403	TRANS PNP SMALL-SIGNAL MBT4403 SOT-23 SM	0 EA	.0	A	Y	N	13.000000
		Ref: Q6-8,Q15,Q17,Q19-20,Q22,Q25,Q33,Q36,Q44,Q52						
4	650 09-10-4416	TRANS SMALL-SIGNAL SST4416 N-CHANNEL J-FET Ref: Q30-31						2.000000

4	660 12-54-0084	IC OP AMP QUAD TL084CD SM	0 EA	.0	A	Y	N	1.000000
		Ref: U10						
4	670 12-54-1082	IC OP-AMP DUAL TLC082CD SINGLE-SUPPLY SM	0 EA	.0	A	Y	N	3.000000
		Ref: U2,U6,U9						
4	680 12-54-1084	IC OP-AMP QUAD TLC084CD SINGLE-SUPPLY SM	0 EA	.0	A	Y	N	3.000000
		Ref: U3-5						
4	690 12-58-0339	IC COMPARATOR QUAD LM339D SM	0 EA	.0	A	Y	N	1.000000
		Ref: U7						
4	700 12-62-4066	IC SWITCH QUAD BI 14-PIN SM TI CD4066BM	0 EA	.0	A	Y	N	2.000000
		Ref: U1,U8						
4	710 21-20-0204	HDR PCB MT SIL 4-PIN x 2mm MALE SHRD VERT MT TH	0 EA	.0	A	Y	N	1.000000
		Ref: P4						
4	720 21-20-1564	HDR PCB MT SIL 4-PIN X .156 MALE VERT-MNT FRIC-LOCK	0 EA	.0	A	Y	N	1.000000
		Ref: P2						
4	730 21-20-1566	HDR PCB MT SIL 6-PIN X .156 MALE VERT-MNT FRIC-LOCK	0 EA	.0	A	Y	N	1.000000
		Ref: P3						
4	740 21-20-2010	HDR PCB MT DIL 10-PIN 2x5x100 MALE SHRD VERT	0 EA	.0	A	Y	N	1.000000
		Ref: P1						
2	585 50-02-0008	PCBA LED CHASSIS ILLUMINATION HD147	10 EA	.0	A	Y	N	1.000000
3	10 01-12-0181	RES CARBON FILM 180R 1/4W 5% TH	0 EA	.0	A	Y	N	4.000000
		Ref: R2,R3,R6,R8						
3	20 18-03-0001	LED ULTRAVIOLET InGaN 0.228-IN 400nm CLEAR T1-3/4 TH	0 EA	.0	A	Y	N	8.000000
		Ref: D1,D3,D5,D7-8,D10,D12,D14						
3	30 21-20-3002	HDR PCB MT SIL 2-PIN x .100 VERT MT FRICT LOCK TH	0 EA	.0	A	Y	N	1.000000
		Ref: J1						
3	40 35-00-0006	PCB SUPPORT-LED END-A MODERN-HD FT3 REV.A Ref: LED PCB to CHASSIS TOP						2.000000

2	590 50-02-0146	PCBA USER INTERFACE HD147	10 EA	.0	A	Y	N	1.000000
3	10 01-24-1500	RES 150R 1% 0805	0 EA	.0	A	Y	N	1.000000
3	20 18-02-0001	Ref: R32 LED YELLOW SUPERBRITE T1(3MM) TH L934SYC	0 EA	.0	A	Y	N	1.000000
3	30 21-20-0202	Ref: D48 HDR PCB MT SIL 2-PIN x 2mm MALE SHRD VERT MT TH	0 EA	.0	A	Y	N	2.000000
3	40 50-00-0146	Ref: H4-5 PCBA USER INTERFACE HD147	0 EA	.0	A	Y	N	1.000000
4	10 01-24-1002	RES 10.0K 1% 0805	0 EA	.0	A	Y	N	2.000000
4	20 01-24-10R0	Ref: R13-14 RES 10.0R 1% 0805	0 EA	.0	A	Y	N	1.000000
4	30 01-24-48R7	Ref: R15 RES 48.7R 1% 0805	0 EA	.0	A	Y	N	16.000000
4	40 01-48-0103	Ref: R1-12,R16-19 POT MONO 10KB LINEAR TAPER 25 mm D-SHAFT	0 EA	.0	A	Y	N	9.000000
4	50 01-48-4103	Ref: R23-31 POT STEREO 10KB LINEAR TAPER 25mm	0 EA	.0	A	Y	N	1.000000
4	60 03-18-0105	Ref: R22 CAP ELEC 1uF 50V 20% RADIAL 5/11/5	0 EA	.0	A	Y	N	1.000000
4	70 03-18-0106	Ref: C30 CAP ELEC 10uF 50V 20% RADIAL 5/11/5	0 EA	.0	A	Y	N	1.000000
4	80 03-52-0473	Ref: C31 CAP X7R 47nF 50V 20% 0805	0 EA	.0	A	Y	N	29.000000

4	90 06-34-0016	DIODE SWITCHING 75V 200mA 6nS SOT-23 SM BAS16LT1	0 EA	.0	A	Y	N	12.000000
		Ref: D1-2,D3,D20-26,D37,D39						
4	100 09-06-7002	TRANS MOSFET N-CHAN 60V 7R5 SOT-23 SM 2N7002	0 EA	.0	A	Y	N	7.000000
		Ref: Q1-7						
4	110 12-64-1543	IC ADC 10 BIT 11 CHANNEL SM TLC1543CDW	0 EA	.0	A	Y	N	1.000000
		Ref: U4						
4	120 15-64-0595	IC 74HCT595 OCTAL SHIFT REG W/ 3-S SO-16 SM	0 EA	.0	A	Y	N	3.000000
		Ref: U1-3						
4	130 18-02-0001	LED YELLOW SUPERBRITE T1(3MM) TH L934SYC	0 EA	.0	A	Y	N	7.000000
		Ref: D27-30,D38,D40,D47						
4	140 18-22-0003	LED YELLOW SUPER 2.0x1.2x1.1mm AP2012SYC SM	0 EA	.0	A	N	N	12.000000
		Ref: D31-36,D41-46						
4	150 18-26-0001	LED TRI-STATE RD/GRN 627/565nm CLR LENS COM-CATH SOT-23 SM	0 EA	.0	A	Y	N	16.000000
		Ref: D4-19						
4	160 21-20-1033	HDR PCB MT DIL 34-PIN 2x17x2mm MALE SHRD VERT MT TH	0 EA	.0	A	Y	N	1.000000
		Ref: H1						
4	170 24-12-0003	ENCODER 18-STEP w/PUSH SW 25mm D-SHFT METAL V-MNT PCB	0 EA	.0	A	Y	N	1.000000
		Ref: ENC1						
4	175 21-34-0036	CAB ASSY 4 PIN 2.54MM PITCH 2.165 LG	0 EA	.0	A	Y	N	1.000000
		Ref: H2 to H3						
4	180 24-31-1102	SWITCH TACT 6mm SQ 4-PIN TH W/ SQ 2.8mm ACTUATOR	0 EA	.0	A	Y	N	2.000000
		Ref: SW5,SW8						
4	190 24-31-1105	SWITCH TACT 6mm SQ 4-PIN TH	0 EA	.0	A	Y	N	7.000000
		Ref: SW1-4,SW6-7,SW9						
2	600 50-02-0236	PCBA POWER SUPPLY w/CONTROL HD147/VETTA-HD SERIES	10 EA	.0	A	Y	N	1.000000
3	1 30-00-0607	SCREW 6-32 x 7/16IN w/LK WASH PPZ STL	10 EA	.0	A	Y	N	4.000000

Line 6
HD 147

3	5 30-51-0158 ASSY	BRACKET MOUNTING POWER SUPPLY	10	EA	.0	A	Y	N	1.000000
3	10 50-00-0119 HD147/VETTA-HD SERIES	PCBA CONTROL POWER SUPPLY	10	EA	.0	A	Y	N	1.000000
4	10 01-00-0101	RES 100R 5% 0805	0	EA	.0	A	Y	N	1.000000
4	20 01-24-1001	Ref: R52 RES 1.00K 1% 0805	0	EA	.0	A	Y	N	3.000000
4	30 01-24-1002	Ref: R7,R9,R11 RES 10.0K 1% 0805	0	EA	.0	A	Y	N	9.000000
4	40 01-24-1003	Ref: R1,R16,R18-19,R23,R27,R33,R37,R40 RES 100K 1% 0805	0	EA	.0	A	Y	N	8.000000
4	50 01-24-1241	Ref: R2,R12-13,R22,R26,R31,R41,R53 RES 1.24K 1% 0805	0	EA	.0	A	Y	N	1.000000
4	60 01-24-1503	Ref: R50 RES 150K 1% 0805	0	EA	.0	A	Y	N	3.000000
4	70 01-24-2210	Ref: R15,R17,R35 RES 221R 1% 0805	0	EA	.0	A	Y	N	1.000000
4	80 01-24-2322	Ref: R46 RES 23.2K 1% 0805	0	EA	.0	A	Y	N	3.000000
4	90 01-24-2493	Ref: R5,R10,R47 RES 249K 1% 0805	0	EA	.0	A	Y	N	2.000000
4	100 01-24-2742	Ref: R38-39 RES 27.4K 1% 0805	0	EA	.0	A	Y	N	3.000000
4	110 01-24-3652	Ref: R14,R45,R55 RES 36.5K 1% 0805	0	EA	.0	A	Y	N	1.000000
4	120 01-24-3743	Ref: R25 RES 374K 1% 0805	0		.0	A		N	.0000 1.000000
4	130 01-24-4022	Ref: R44 RES 40.2K 1% 0805	0	EA	.0	A	Y	N	2.000000

Ref: R3,R32

Line 6
HD 147

4	140 01-24-4750	RES 475R 1% 0805	0 EA	.0	A	Y	N	2.000000
		Ref: R54,R57						
4	150 01-24-4751	RES 4.75K 1% 0805	0 EA	.0	A	Y	N	7.000000
		Ref: R20,R28,R34,R48,R24,R49,R51						
4	160 01-24-4752	RES 47.5K 1% 0805	0 EA	.0	A	Y	N	6.000000
		Ref: R4,R6,R21,R29-30,R36						
4	170 01-24-47R5	RES 47.5R 1% 0805	0 EA	.0	A	Y	N	1.000000
		Ref: R56						
4	180 01-24-6191	RES 6.19K 1% 0805	0 EA	.0	A	Y	N	3.000000
		Ref: R8,R42-43						
4	190 01-70-0001 0603 SM	THERMISTOR NTC 100K@25C	0 EA	.0	A	Y	N	1.000000
		Ref: NTC1						
4	200 03-14-0476 6.3/7/5	CAP ELEC 47uF 25V 20% RADIAL	0 EA	.0	A	Y	N	5.000000
		Ref: C1-3,C6,C8						
4	210 03-18-0105 5/11/5	CAP ELEC 1uF 50V 20% RADIAL	0 EA	.0	A	Y	N	1.000000
		Ref: C12						
4	220 03-18-0106 5/11/5	CAP ELEC 10uF 50V 20% RADIAL	0 EA	.0	A	Y	N	2.000000
		Ref: C4,C10						
4	230 03-50-0102	CAP NPO 1nF 50V 5% 0805	0 EA	.0	A	Y	N	2.000000
		Ref: C7,C17						
4	240 03-50-0221	CAP NPO 220pF 50V 20% 0805	0 EA	.0	A	Y	N	3.000000
		Ref: C20-21,C24						
4	250 03-52-0101	CAP X7R 100pF 50V 20% 0805	0 EA	.0	A	Y	N	1.000000
		Ref: C5						
4	260 03-52-0104	CAP X7R 0.1uF 50V 20% 0805	0 EA	.0	A	Y	N	2.000000
		Ref: C9,C18						
4	270 03-52-0473	CAP X7R 47nF 50V 20% 0805	0 EA	.0	A	Y	N	8.000000
		Ref: C11,C13-16,C22-23,C25						
4	280 03-52-1103	CAP X7R 10nF 100V 10% 0805	Ref: C19,C26-27					3.000000

4	290 06-28-8418	DIODE ZENER 18V 5% 350mW SOT-23 SM BZX84C18	0 EA	.0	A	Y	N	2.000000
		Ref: D1,D8						
4	300 06-28-8451	DIODE ZENER 5.1V 5% 350mW SOT-23 SM BZX84C5V1	0 EA	.0	A		N	2.000000
		Ref: D3,D9						
4	310 06-34-0016	DIODE SWITCHING 75V 200mA 6nS SOT-23 SM BAS16LT1	0 EA	.0	A	Y	N	6.000000
		Ref: D2,D4-7,D10						
4	320 09-06-7002	TRANS MOSFET N-CHAN 60V 7R5 SOT-23 SM 2N7002	0 EA	.0	A	Y	N	4.000000
		Ref: Q2,Q4,Q6,Q9						
4	330 09-10-0042	TRANS NPN POWER 300V 200mA SOT-23 SM MMBTA42	0 EA	.0	A	Y	N	1.000000
		Ref: Q11						
4	340 09-10-4401	TRANS NPN SMALL-SIGNAL MBT4401 SOT-23 SM	0 EA	.0	A	Y	N	3.000000
		Ref: Q12,Q15-16						
4	350 09-10-4403	TRANS PNP SMALL-SIGNAL MBT4403 SOT-23 SM	0 EA	.0	A	Y	N	8.000000
		Ref: Q1,Q3,Q5,Q7-8,Q13-14,Q17						
4	360 12-50-0431	IC REG ADJ PREC SHUNT <36V TL431 SOT23-5 SM	0 EA	.0	A	Y	N	1.000000
		Ref: Q10						
4	370 12-58-0339	IC COMPARATOR QUAD LM339D SM	0 EA	.0	A	Y	N	1.000000
		Ref: U1						
4	380 12-58-0393	IC COMPARATOR DUAL LM393D-T SM	0 EA	.0	A	Y	N	1.000000
		Ref: U2						
4	390 15-68-3844	IC CONTROLLER PWM SO-8 UC3844D8	0 EA	.0	A	Y	N	1.000000
		Ref: U3						
4	400 21-20-0021	HDR SIL 20-PIN PCB-MNT	0	.0	A		N	.0000 1.000000
		Ref: H1						
3	20 50-00-0236	PCBA POWER SUPPLY HD147/VETTA-HD SERIES	10 EA	.0	A	Y	N	1.000000
		Ref: R24						
4	10 01-21-0623	RES METAL OXIDE 62K 1W 5% TH	0 EA	.0	A	Y	N	.0000 1.000000

Line 6
HD 147

4	20 01-22-0102	RES METAL OXIDE 1K 2W 5%	0 EA	.0 A Y N	.0000	2.000000
4	30 01-22-0390	Ref: R1-2 RES METAL OXIDE 39R 2W 5% TH	0 EA	.0 A Y N	.0000	4.000000
4	40 01-22-0473	Ref: R8,R11,R23,R25 RES METAL OXIDE 47K 2W 5% TH	0 EA	.0 A Y N	.0000	2.000000
4	50 01-22-0750	Ref: R26-27 RES METAL OXIDE 75R 2W 5% TH	0 EA	.0 A N	.0000	4.000000
4	60 01-32-1000	Ref: R13-15,R22 RES METAL FILM 100R 1/8W 1%	0	.0 A N	.0000	5.000000
4	70 01-32-1001	Ref: R3-7 RES METAL FILM 1.00K 1/8W 1%	0	.0 A N	.0000	2.000000
4	80 01-32-1002	Ref: R9-10 RES METAL FILM 10.0K 1/8W 1%	0	.0 A N	.0000	1.000000
4	90 01-32-1004	Ref: R16 RES METAL FILM 1.00M 1/8W 1%	0	.0 A N	.0000	2.000000
4	100 01-32-10R0	Ref: R18-19 RES METAL FILM 10R 1/8W 1% TH	0	.0 A N	.0000	2.000000
4	110 01-32-20R0	Ref: R20-21 RES METAL FILM 20R 1/8W 1% TH	0	.0 A N	.0000	2.000000
4	120 03-00-0180	Ref: R12,R17 CAP CER DISC 18pF 3KV 5% TH	0 EA	.0 A N	.0000	2.000000
4	130 03-00-0331	Ref: C10-11 CAP CER DISC 330pF 1000V 10% TH 6/4.5/5	0 EA	.0 A Y N	.0000	4.000000
4	140 03-00-0471	Ref: C26-28,C31 CAP CER DISC 470pF 1000V 10% TH 6/4.5/5	0 EA	.0 A Y N	.0000	4.000000
4	150 03-00-1104	Ref: C23,C25,C34-35 CAP CER 0.1uF 100V 10% TH 200/	0	.0 A N	.0000	10.000000
4	160 03-00-2471	Ref: C1-4,C9,C18,C20-21,C30,C32 CAP CER 470pF 100V 10% TH 150/ Ref: C14,C17,C19,C22	0	.0 A N	.0000	4.000000

4	170 03-10-0228	CAP ELEC 2200uF 10V 20% 105C LowZ 0.04R RADIAL 12.5/25/5	0 EA	.0	A Y N		1.000000
		Ref: C8					
4	180 03-14-0476	CAP ELEC 47uF 25V 20% RADIAL 6.3/7/5	0 EA	.0	A Y N		1.000000
		Ref: C29					
4	190 03-14-1227	CAP ELEC 220uF 25V 20% RADIAL LowZ 0.15R RADIAL 8/15/5	0 EA	.0	A Y N		3.000000
		Ref: C7,C15-16					
4	200 03-16-1108	CAP ELEC 1000uF 35V 20% 105C LowZ 0.04R RADIAL 12.5/31.5/5	0 EA	.0	A Y N		2.000000
		Ref: C5-6					
4	210 03-20-0227	CAP ELEC 220uF 63V 20% 105C LowZ 0.07R RADIAL 12.5/20/5	0 EA	.0	A Y N		2.000000
		Ref: C12-13					
4	220 03-22-0108	CAP ELEC 1000uF 200V 20% SNAP- IN RADIAL 25/50/10	0 EA	.0	A Y N		2.000000
		Ref: C36-37					
4	230 03-24-0223	CAP MET-POLY 22nF 250V 10% TH 10.3/4.4/7.5/7.5	0 EA	.0	A Y N		1.000000
		Ref: C33					
4	240 03-24-0683	CAP MET-POLY 68nF 50V 5% TH 7.	0	.0	A N	.0000	1.000000
		Ref: C24					
4	250 03-41-0224	CAP X-CAP 0.22uF 275VAC 20% POLYPROPYLENE 18/9.5/17.5/15	0 EA	.0	A Y N		1.000000
		Ref: C40					
4	260 03-42-0471	CAP Y-CAP 470pF 250VAC 20% TH CER DISC 8D/7/7.5	0 EA	.0	A Y N		3.000000
		Ref: C38-39,C41					
4	270 04-00-0271	INDUCTOR DRUM-CORE 270uH@ 4MHz 840mA TH	0 EA	.0	A N		1.000000
		Ref: L1					
4	280 06-00-4148	DIODE SMALL-SIGNAL 100V 300mA 4nS DO-35 TH 1N4148	0 EA	.0	A Y N		4.000000
		Ref: D5-6,D10,D12					
4	285 06-02-0120	DIODE ULTRA FAST 200V 1A 50nS	0 EA	.0	A Y N	.0000	3.000000
		Ref: D2-4					
4	290 06-08-0020	DIODE ZENER 20V 5% 1W DO-41 TH 1N4747A	0 EA	.0	A Y N		1.000000

Ref: D8

Line 6
HD 147

4	300 06-08-0068	DIODE ZENER 6.8V 5% 1W DO-41 TH 1N4736A	0 EA	.0	A Y N		1.000000
		Ref: D11					
4	310 06-12-0160	DIODE ULTRA FAST 600V 1A 50ns 59-04 PLASTIC TH MUR160	0 EA	.0	A Y N		1.000000
		Ref: D16					
4	320 06-12-1045	DIODE SCHOTTKY 45V 10A TO-220AC TH MBR1045	0 EA	.0	A Y N		1.000000
		Ref: D1					
4	330 06-16-0008	DIODE BRIDGE-RECT 8A 600V 4-PIN SIL TH KBU8J	0 EA	.0	A Y N		1.000000
		Ref: D18					
4	340 06-24-0460	DIODE ULTRAFast 4A 600V TH MUR460	0 EA	.0	A Y N		2.000000
		Ref: D14,D17					
4	350 06-24-1660	DIODE ULTRAFast DUAL 8A 600V COM CATHODE MUR1660CT	0 EA	.0	A Y N		4.000000
		Ref: D7,D9,D13,D15					
4	360 09-00-1616	TRANS BIPOLAR NPN SMALL-SIGNAL	0	.0	A N	.0000	2.000000
		Ref: Q1-2					
4	370 09-06-0460	TRANS MOSFET N-CHAN PWR 500V 0.27R TO-247AC TH IRFP460	0 EA	.0	A Y N		2.000000
		Ref: Q4,Q6					
4	380 09-06-7000	TRANS MOSFET N-CHAN 60V 5R TO-	0 EA	.0	A Y N	.0000	2.000000
		Ref: Q3,Q5					
4	390 11-10-0002	INDUCTOR CUR-SENSING TH PREMIER MAGNETICS PM-CI02	0 EA	.0	A Y N		1.000000
		Ref: T6					
4	400 11-10-0584	XFMR OFFLINE GATE DR TH PULSE P0584	0 EA	.0	A Y N	P Y N	1.000000
		Ref: T3					
4	410 11-10-0831	INDUCTOR POWER FORWARD CONVERTER ICE ICA-0831	0 EA	.0	A Y N		1.000000
		Ref: L2					
4	420 11-30-0012	XFMR CCFL 8P TH	0	.0	A N	.0000	1.000000
		Ref: T5					
4	430 11-30-0617	XFMR VERT BOBBIN 49/v20/-1rtg ICE ICA-0617	0 EA	.0	A Y N		1.000000
		Ref: T4					
4	440 11-30-0633	XFMR HOUSE-KEEPING ICE ICA-0633	0 EA	.0	A Y N		1.000000

4	450 12-12-1234	IC CONTROLLER PWM POWER-INTERGRATIONS TOP234Y	0 EA	.0	A	Y	N	1.000000
		Ref: U1						
4	460 21-20-0003	HDR SIL 3-PIN x 2mm PCB-MNT MALE	0 EA	.0	A	Y	N	1.000000
		Ref: J2						
4	470 21-20-0005	HDR SIL 2-PIN x .200 PCB-MNT	0	.0	A		N	.0000 2.000000
		Ref: J3-4						
4	480 21-20-1566	HDR PCB MT SIL 6-PIN X .156 MALE VERT-MNT FRIC-LOCK	0 EA	.0	A	Y	N	1.000000
		Ref: H2						
4	490 21-20-1568	HDR PCB MT SIL 8-PIN X .156 MALE VERT-MNT FRIC-LOCK	0 EA	.0	A	Y	N	1.000000
		Ref: H1						
4	497 21-20-2075	HDR PCB MT SIL 2-PIN X 7.5mm MALE VERT MT FRIC-LOCK TH	0 EA	.0	A	Y	N	2.000000
		Ref: J6,J7						
4	500 21-20-3002	HDR PCB MT SIL 2-PIN x .100 VERT MT FRICT LOCK TH	0 EA	.0	A	Y	N	1.000000
		Ref: J5						
4	530 21-29-0006	WIRE 20AWG 70.00mm INSUL	0 EA	.0	A	Y	N	.0000 1.000000
		Ref: J6						
4	540 21-34-0006	CAB SIL 2-PIN 1.95" .156" PITCH	0 EA	.0	A	Y	N	1.000000
		Ref: F1						
4	560 24-19-6325	FUSE 6.3 AMP 250V 5X20mm DOM F	0 EA	.0	A	Y	N	1.000000
		Ref: F1						
4	570 30-00-0440	SCREW #4-40 X 3/8 Socket CAP ALLOY	0 EA	.0	A	Y	N	10.000000
		Ref: Heatsink H5-D7,D9,D13,D15/Heatsinks to PCB						
4	580 30-00-0607	SCREW 6-32 x 7/16IN w/LK WASH PPZ STL	0 EA	.0	A	Y	N	1.000000
		Ref: d1						
4	590 30-00-1632	SCREW 6-32 x 3/8IN PPB TAP-TITE STL	0 EA	.0	A	Y	N	2.000000
		Ref: PCB Brace to Heatsinks						
4	600 30-00-2632	SCR 6-32 x .500 LG SHCS BLK Ref: Heatsink H4-Q4, Q6, D18	0 EA	.0	A	Y	N	3.000000

Line 6
HD 147

4	610 30-00-3125	SCREW 4-40 x .3125 PPB STL	0 EA	.0	A	Y	N	1.000000
4	620 30-03-0400	Ref: U1-H6 WASHER #4 SPLIT LOCKWASHER	0 EA	.0	A	Y	N	10.000000
	ZINC							
4	630 30-03-0425	Ref: Heatsink H5-D7,D9,D13,D15/Heatsinks to PCB WASHER,#4,0.125" ID,.233" OD,	0 EA	.0	A	Y	N	4.000000
	.018 HEIGHT,ZINC PLATE							
4	640 30-03-0600	Ref: Heatsink H5-D7,D9,D13,D15 WASHER #6 SPLIT LOCKWASHER	0 EA	.0	A	Y	N	3.000000
	ZINC							
4	650 30-03-0606	Ref: Heatsink H4-Q4, Q6, D18 WASHER #6 FLAT ZINC	0 EA	.0	A	Y	N	3.000000
4	660 30-06-0440	Ref: Heatsink H4-Q4, Q6, D18 NUT HEX .242 4-40 STL/ZNC	0 EA	.0	A	Y	N	1.000000
4	665 30-12-0632	Ref: U1-H6 STANDOFF HEX .250 6-32 F-F 1IN	0 EA	.0	A	Y	N	1.000000
	F-F AL							
4	680 30-15-0404	Ref: D1 SHOULDER BUSHING TO-220 VALPAK	0 EA	.0	A	Y	N	4.000000
	NY04-040-140-012TWG							
4	690 30-51-0057	Ref: Heatsink H5-D7,D9,D13,D15 HEAT SINK, BLACK ANODIZED AL,	0 EA	.0	A	Y	N	1.000000
	WAKEFIELD #287-1AB							
4	700 30-51-6001	Ref: H6 Heat sink, HD 2 P/S#1	0 EA	.0	A	Y	N	1.000000
4	710 30-51-6002	Ref: H4 Heat sink, HD 2 P/S#2	0 EA	.0	A	Y	N	1.000000
4	720 30-63-4002	Ref: H5 INSULATOR THERMAL K6 TO-247	0 EA	.0	A	Y	N	3.000000
4	730 30-63-4005	Ref: Heatsink H4-Q4,Q6 PAD THERMAL TO-220	0 EA	.0	A	Y	N	4.000000
	BERG-400-7-54							
2	610 50-02-0237	Ref: Heatsink H5-D7,D9,D13,D15 PCBA SPEAKER OUT	10 EA	.0	A	Y	N	1.000000
	HD147/VETTA-HD SERIES							
3	5 03-36-0102	CAP ESTR 1nF 100V 5% TH	Ref: C1-2					2.000000

3	10	03-50-0102	CAP NPO 1nF 50V 5% 0805	0	EA	.0	A	Y	N	4.000000
3	20	21-00-6616	Ref: C47,C53-54,C63 JACK 1/4" TRS 6-PIN PCB MT HORIZ TH	0	EA	.0	A	Y	N	4.000000
3	30	21-20-0204	Ref: J16,J18,J28,J30 HDR PCB MT SIL 4-PIN x 2mm MALE SHRD VERT MT TH	0	EA	.0	A	Y	N	1.000000
3	40	21-20-1564	Ref: H3 HDR PCB MT SIL 4-PIN X .156 MALE VERT-MNT FRIC-LOCK	0	EA	.0	A	Y	N	1.000000
3	45	21-20-1574	Ref: J1 HDR PCB MT SIL 4-PIN X .156 MA	0		.0	A		N	.0000 1.000000
3	50	21-20-3002	Ref: J8 HDR PCB MT SIL 2-PIN x .100 VERT MT FRICT LOCK TH	0	EA	.0	A	Y	N	1.000000
3	60	24-09-0128	Ref: J7 SWITCH SLIDE DPDT RA PCB MT ON-OPEN-ON SWEETA SPA-128	0	EA	.0	A	Y	N	1.000000
3	70	30-18-3030	Ref: SW1 CLIP GND PCB .30x.30x.07	0	EA	.0	A	Y	N	4.000000

Ref: J42-45



HD147 Factory reinstall/Reset

Hold the A and D buttons down while powering up.

HD147 Flash code version ID

Hold C button down while powering up. B, C and D LEDs will flash to show the flash code version. “B” designates the major version, “C” and “D” LEDs designate the first and second decimal points, respectively, in a point release. For example, if “B” flashes once, “C” once and “D” twice, the flash code version is 1.12.

HD147 OTP/Boot code version ID

Hold B button down while powering up. B, C and D LEDs will flash to show the OTP/boot code version. “B” designates the major version, “C” and “D” LEDs designate the first and second decimal points, respectively, in a point release. For example, if “B” flashes once, “C” once and “D” twice, the OTP/boot code version is 1.12.



Mechanical Assembly Instructions: Rev B

HD147 p/n 59-00-0515



Forward and Notes

The information in this booklet applies to the HD147 mechanical assembly only.

This booklet deals with assembling the major sub-assemblies, the final product, and quality/inspection considerations. See also the Related Electrical assembly documentation, for major considerations in assembling the electrical components of the PCBs (through the soldering process and preparation of the board for addition of custom components).

A note on the text: the illustrations in this book are for reference only. In some cases, color and geometry of illustrations may not accurately reflect the color or exact geometry of actual parts.

- Unless otherwise noted, all dimensions are in inches.
- Part identifying notes are in this format: Description P/N (P/N = part number)
- Drawings are not to scale.
- Cotton gloves should be worn when handling the chrome chassis parts.
- Special care must be taken when handling the chrome chassis parts, to avoid scratches & dings.



Engineering

Table of contents:

BASE CHASSIS SUB ASSEMBLY3

a) Feet Installation	4
b) Heat Sink Spacer Installation	5
c) Line filter PCBA and Main PCBA standoff installation	6
d) Power Amplifier Installation	7
e) Power Amplifier Cable installation	8
f) Power Supply installation	9
g) Power Supply to Power Amplifier Cable installation	10
h) Back Panel subassembly	11
i) Back Panel subassembly installation	13
j) Power Supply Cable to Main PCBA attachment	17
k) Line Filter PCBA installation	18
l) Power Switch Cable installation	20

TOP CHASSIS SUB ASSEMBLY21

a) Top Chassis subassembly exploded view	22
--	----

TEST AND INSPECT THE COMPLETED UNIT61

COMPONENT SETTINGS FOR FINAL PACKAGING61

PACK-OUT LIST62

BASE CHASSIS ASSEMBLY

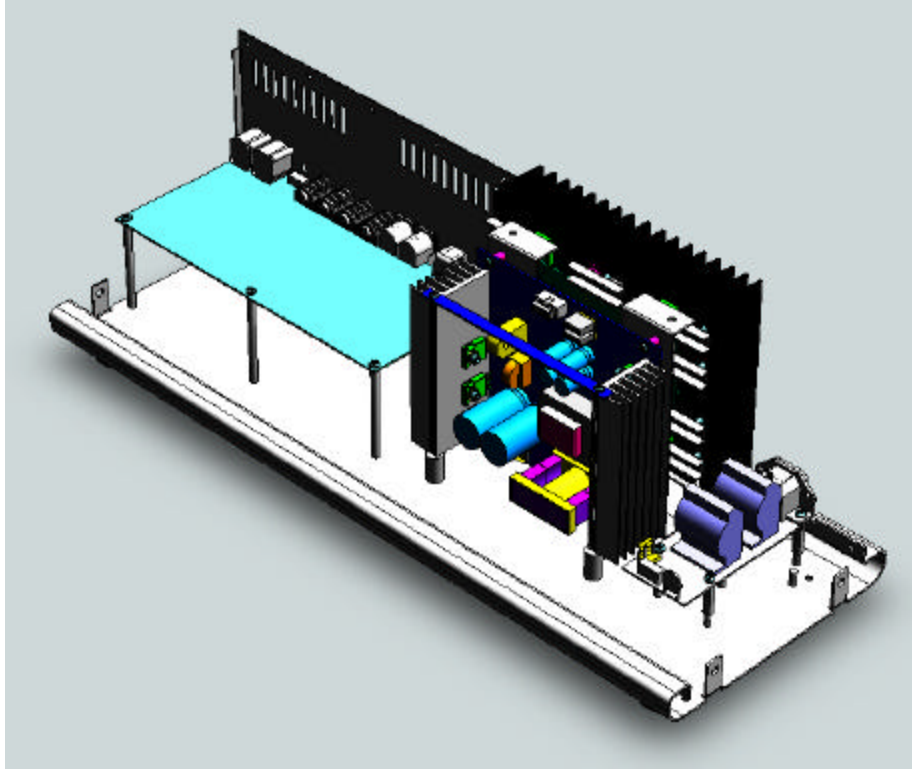

Full Base Chassis Sub-Assembly

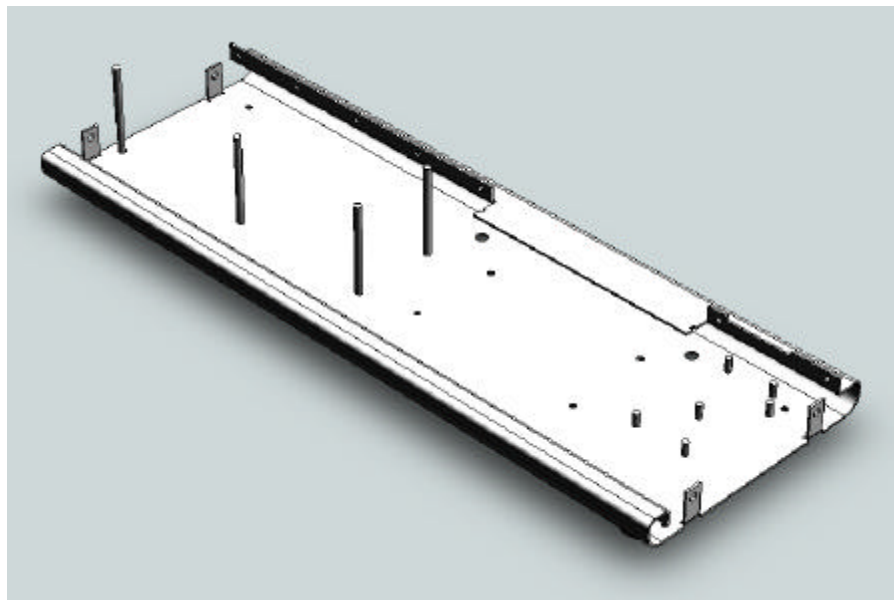

Base Chassis p/n 30-51-0122

LINE 6 Engineering

1) Install 4 rubber feet (p/n 30-75-0008) with 4 each 10-32 x .5/8" screws (30-00-0047). Torque to 8-10 in/lbs)

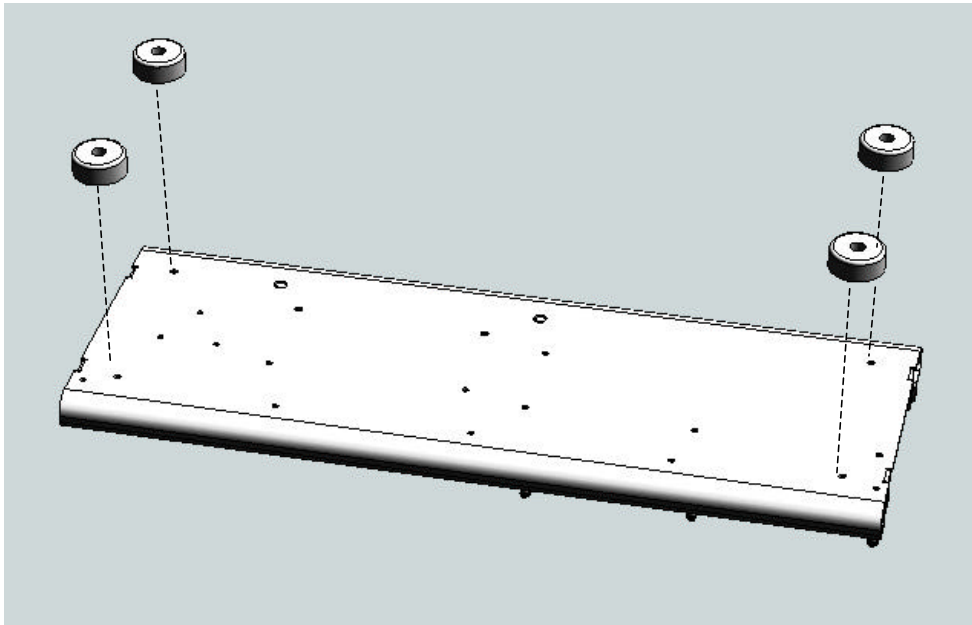

Foot installation onto bottom surface of Base Chassis - 4 places

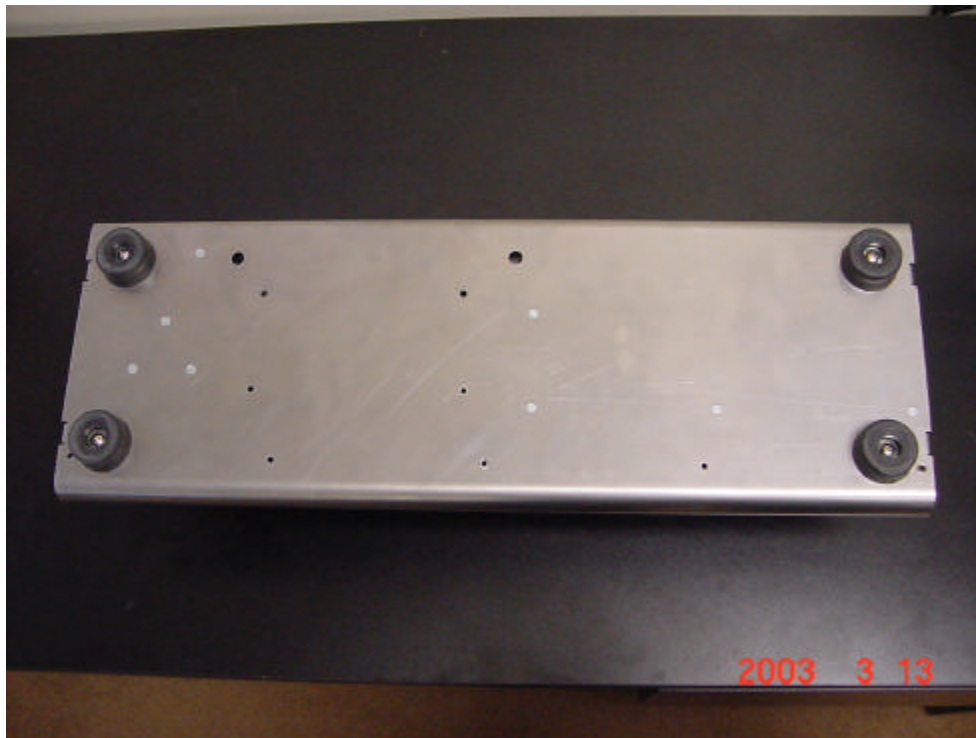

Foot installation complete

LINE 6

Engineering

2) Install 2 HEAT SINK SPACERS (p/n 30-15-0019) with two 6-32 x .75" screws (30-00-0018).

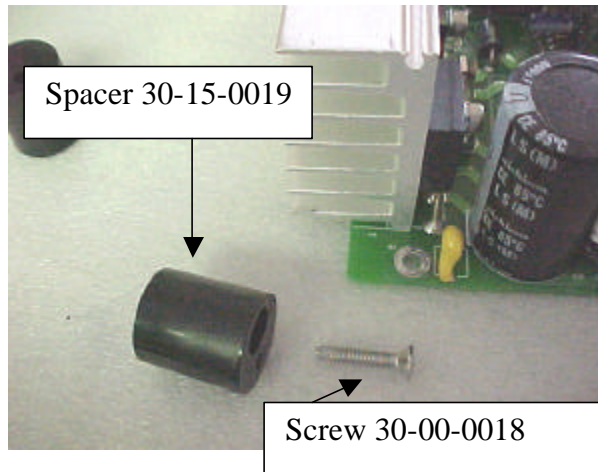

Screw spacer into heat sink, until the screw bottoms out in the spacer.

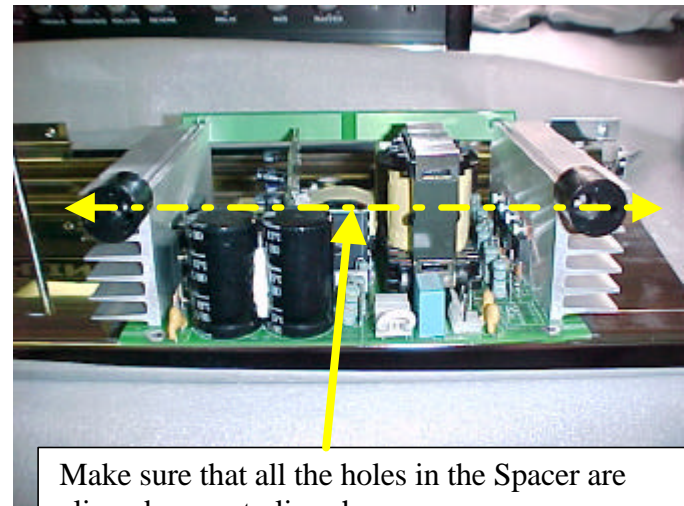
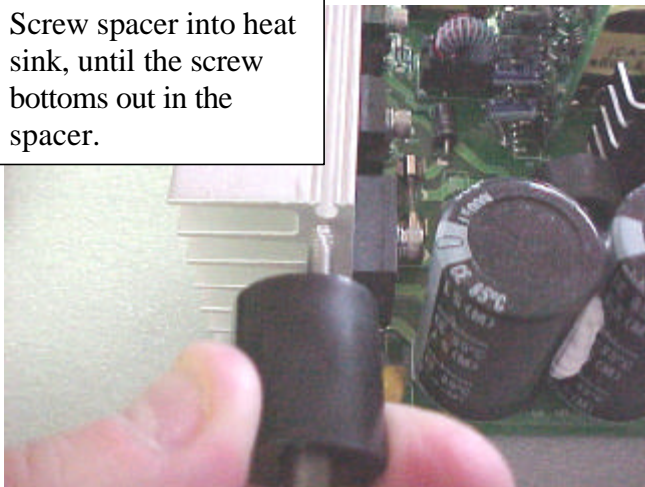

Make sure that all the holes in the Spacer are aligned on centerline shown. Chassis mounting holes on the Spacer should be facing outward, away from the PCBA transformer.

LINE 6

Engineering

3) Install five, 1 inch long hex standoffs (p/n 30-12-8418) into pre-assembled .5" chassis standoffs. Torque standoffs to 8 in-lbs.

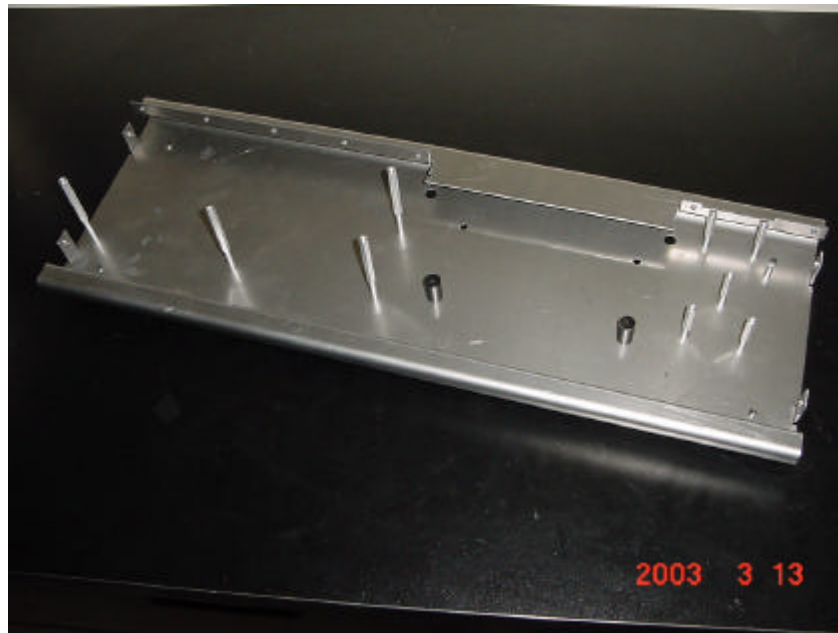
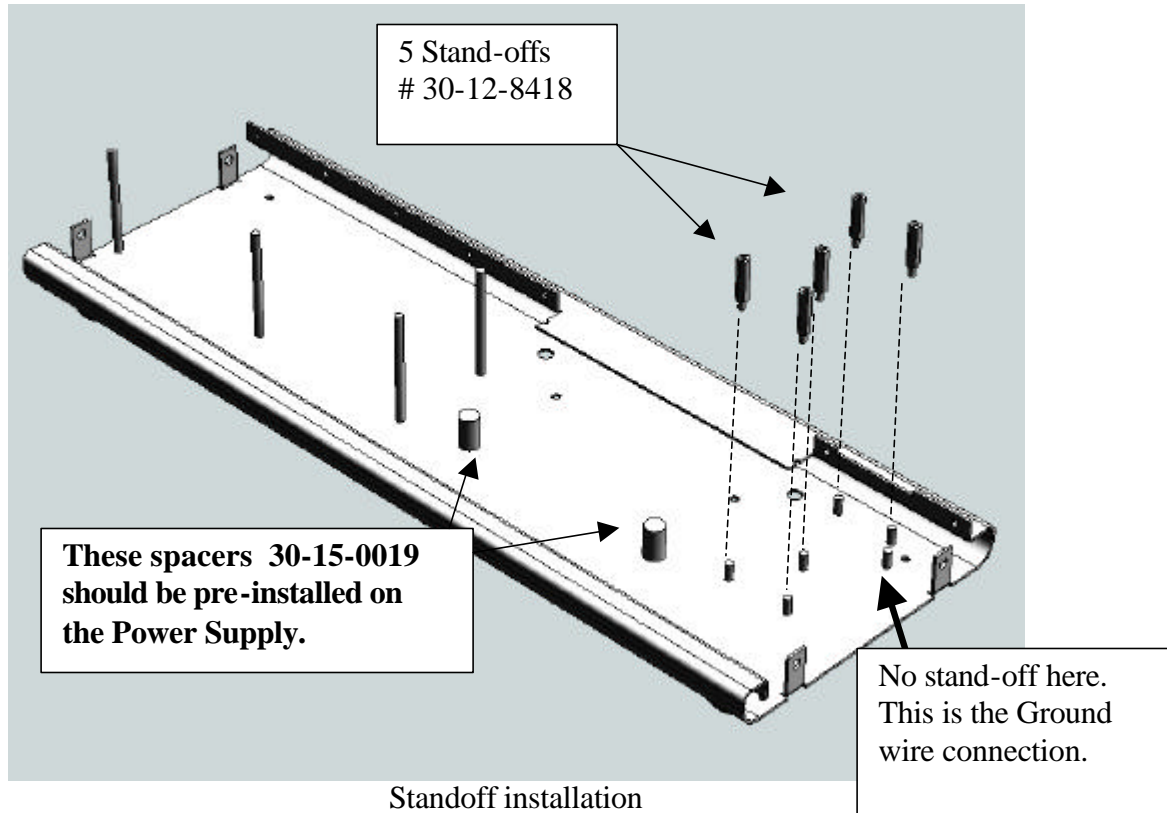

LINE 6

Engineering

4) Install 1 each Power Amplifier assy (p/n 50-00-9102) with 2 each 6-32 self tapping screws (p/n 30-00-0018). Torque screws to 10-12 in-lbs.

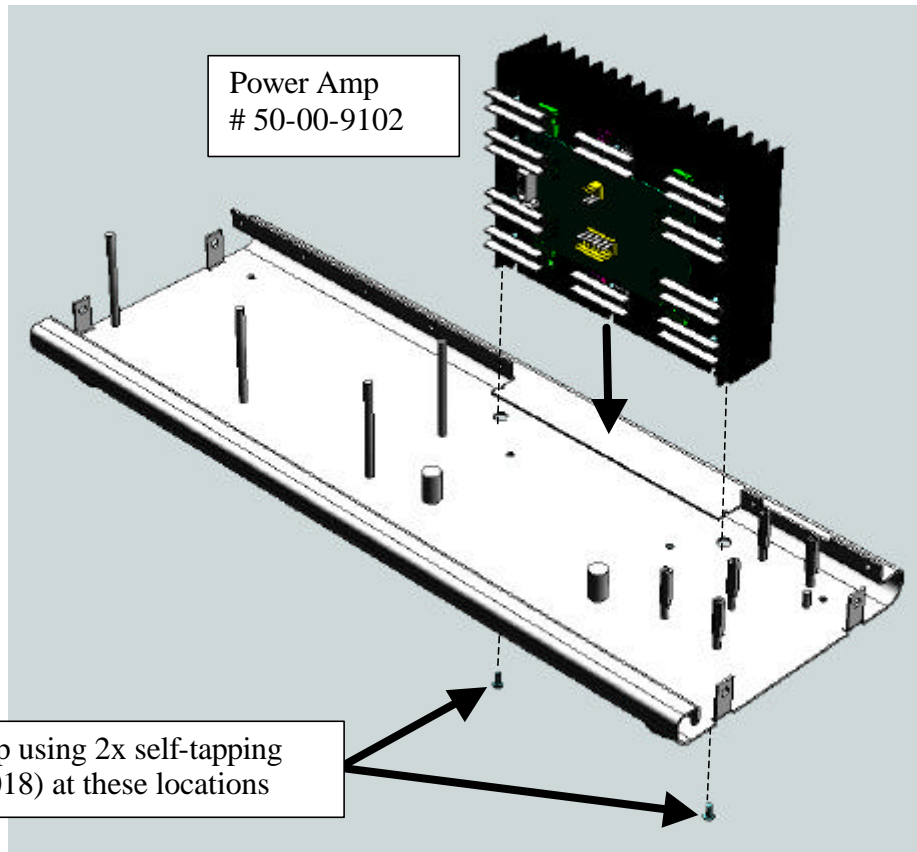

Power Amplifier Assembly onto Base Chassis

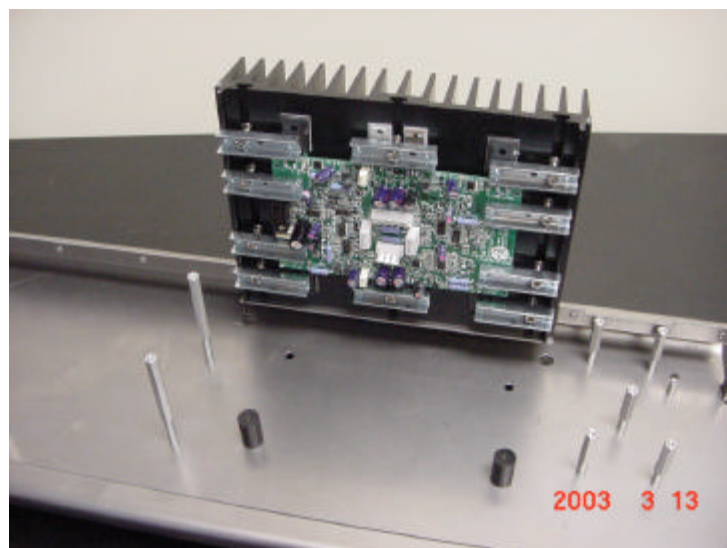

Completed Installation

5) Install Power Amplifier cables

1 each (# 21-34-0008-2, # 21-30-0009-4, # 21-34-0007-3)

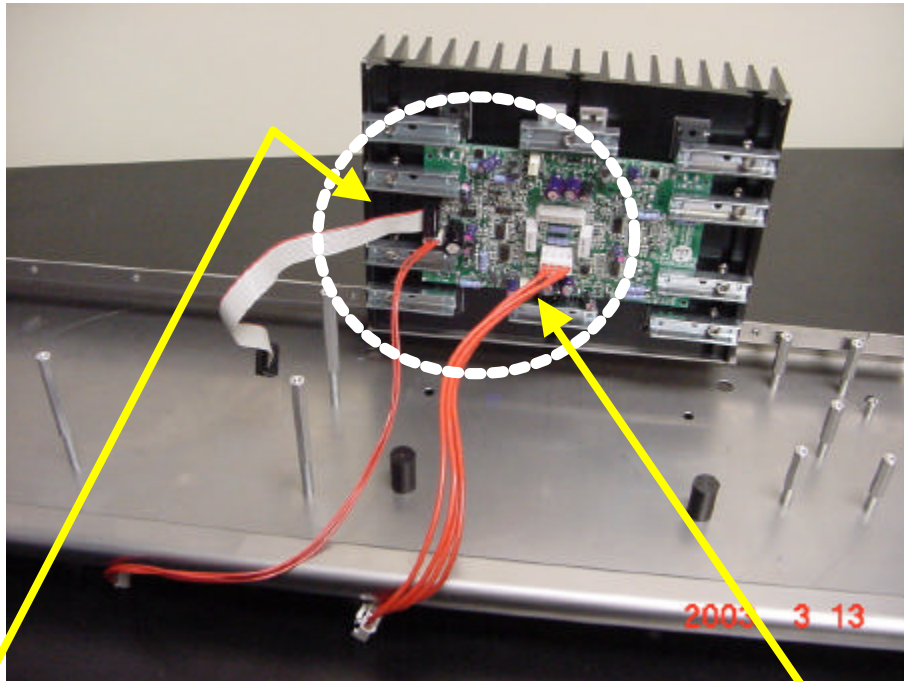

Power Amplifier Cable Installation

21-30-0009-4
Power Amp to Main.

21-34-0008-2
Power Amp to
Speaker out PCBA.

21-34-0007-3
Power Amp to
Speaker Out
PCBA.

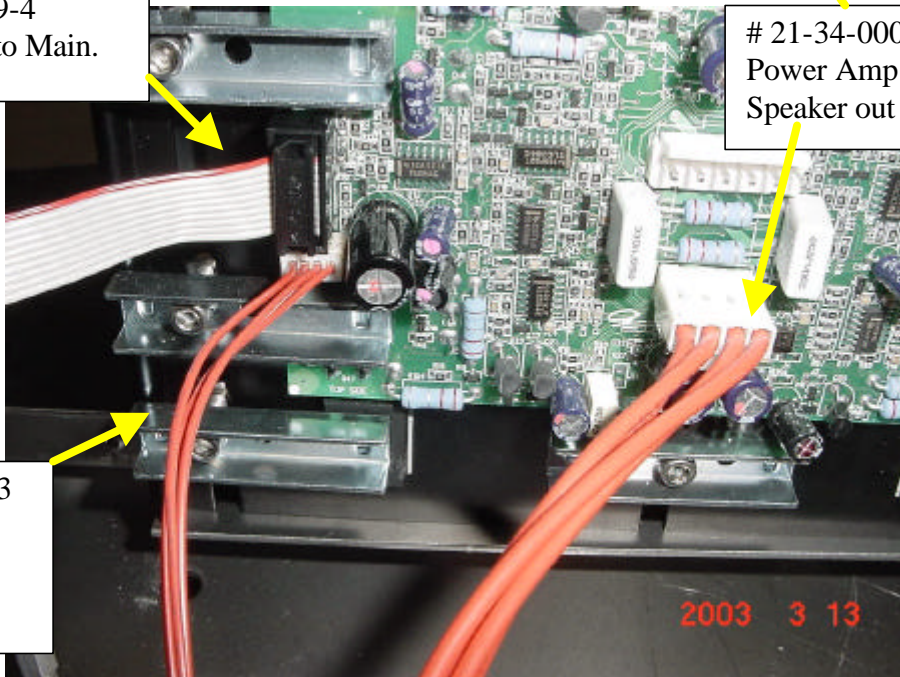

PCBA and Cable Connector detail

LINE 6

Engineering

6) Install 1 each Power Supply Assembly (p/n 50-02-0236)

- Prior to mounting the Bracket, install cable assembly (p/n 21-34-0021-3) onto Power Supply and Power Amplifier (see next figure #7).
- Install the Power Supply using 2 each 10-32UNF-2A screws (#30-00-1012) with lock washer (#30-03-0001) . Torque screws to 12-14 in-lbs.
-

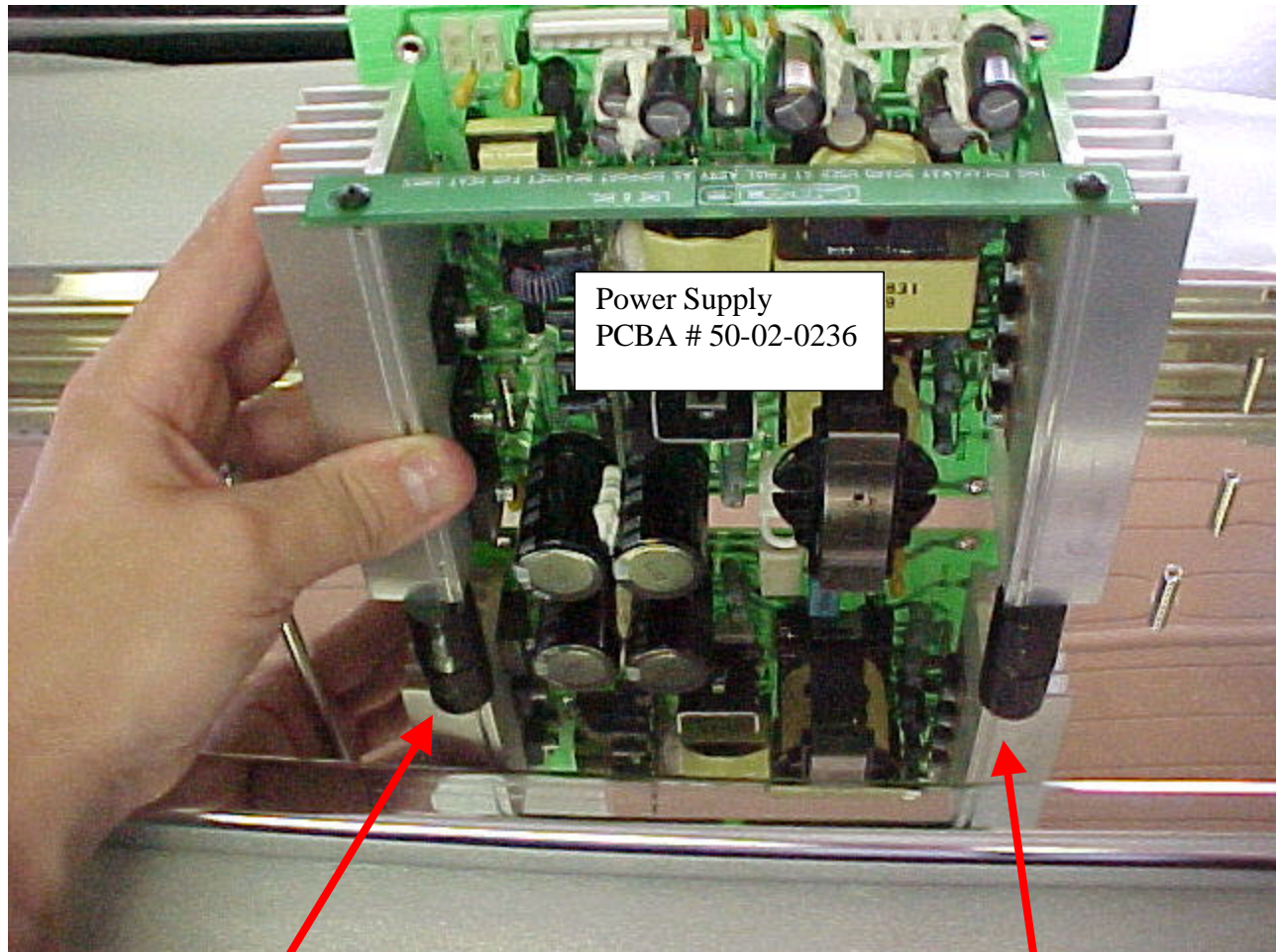

Power Supply Installation

To mount the power supply Spacers (30-15-0019) to the chassis,
Use screws #30-00-0046 #6 Sheet metal Phillips Pan Zinc (2 per)

LINE 6 Engineering

7) Install Power supply cable (21-34-0021-3) to Power Amplifier assembly prior to mounting the Power Supply Bracket onto the Base Chassis.

- Make sure that Jumper Cable #21-34-0006, is **INSTALLED** for 100/120v units. It must be removed for 220/240v units.

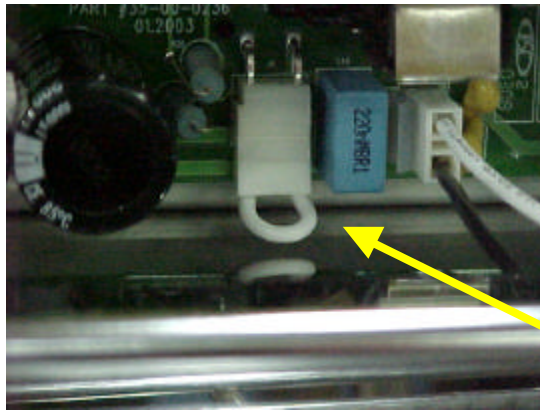

Cable – Voltage jumper.
#21-34-0006.
100/120V – INSTALLED
220/240V – NOT INSTALLED.

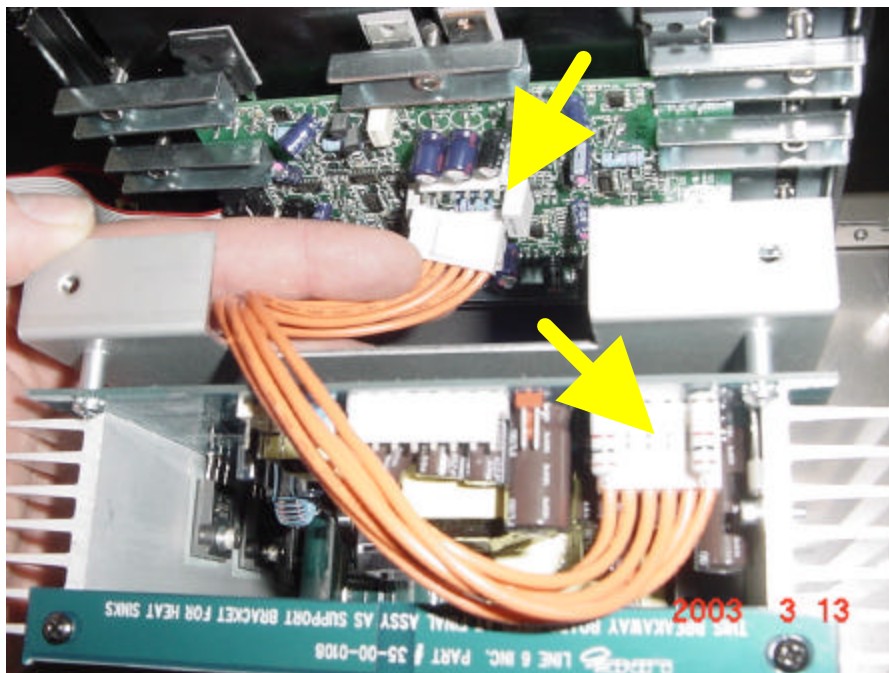

Power Supply to Power Amplifier cable installation

LINE 6

Engineering

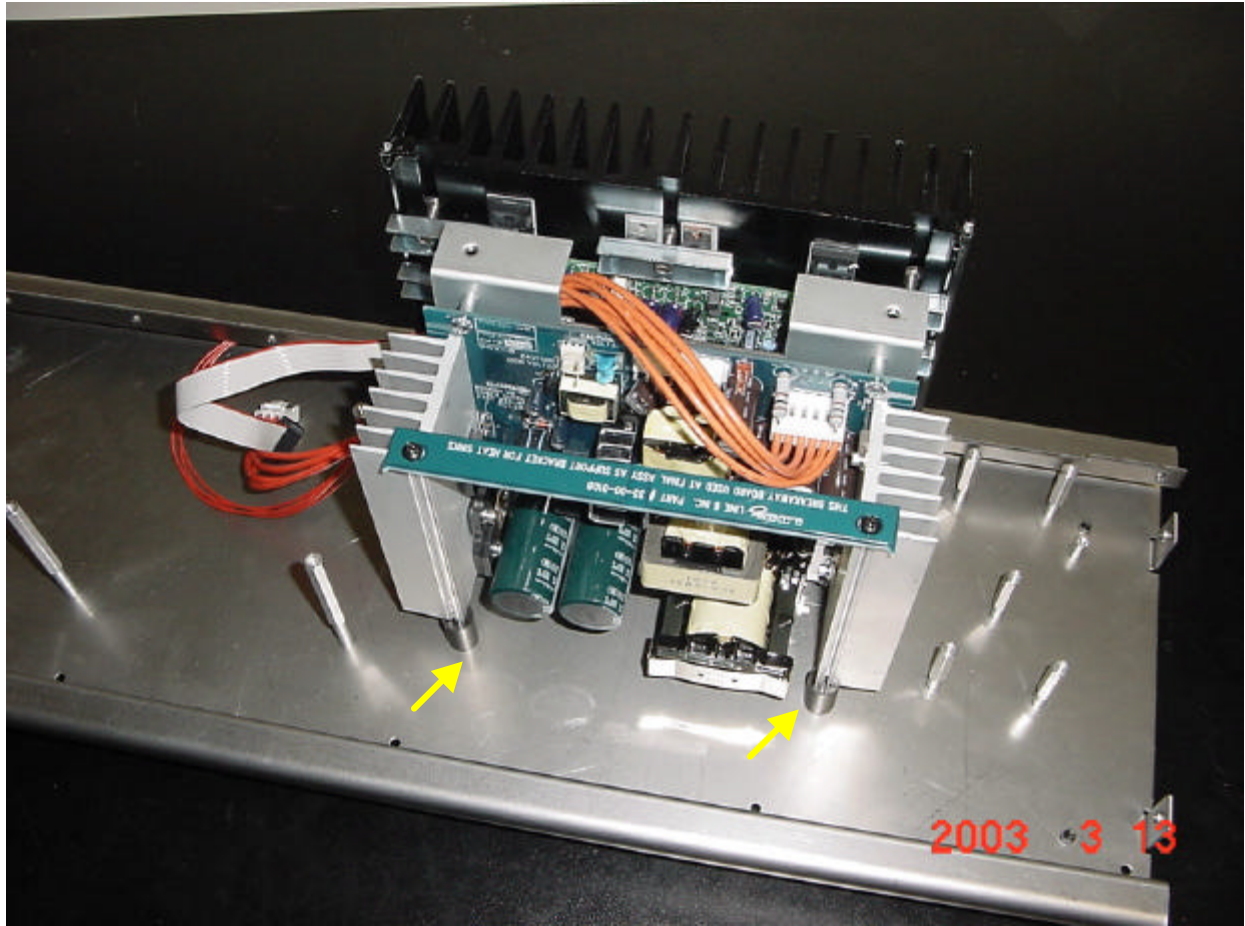

Completed Power Supply Installation

Note :

To mount the power supply Spacers (30-15-0019) to the chassis,
Use screws #30-00-0046 #6 Sheet metal Phillips Pan Zinc (2 per), at
positions shown, from the bottom of the chassis base.

LINE 6

Engineering

8) SUB-ASSEMBLY: assemble the following parts; 1 each I/O PANEL p/n 30-51-0126,
1 each MAIN PCBA p/n 50-00-0204,
1 each SPEAKER OUT PCBA p/n 50-02-0237

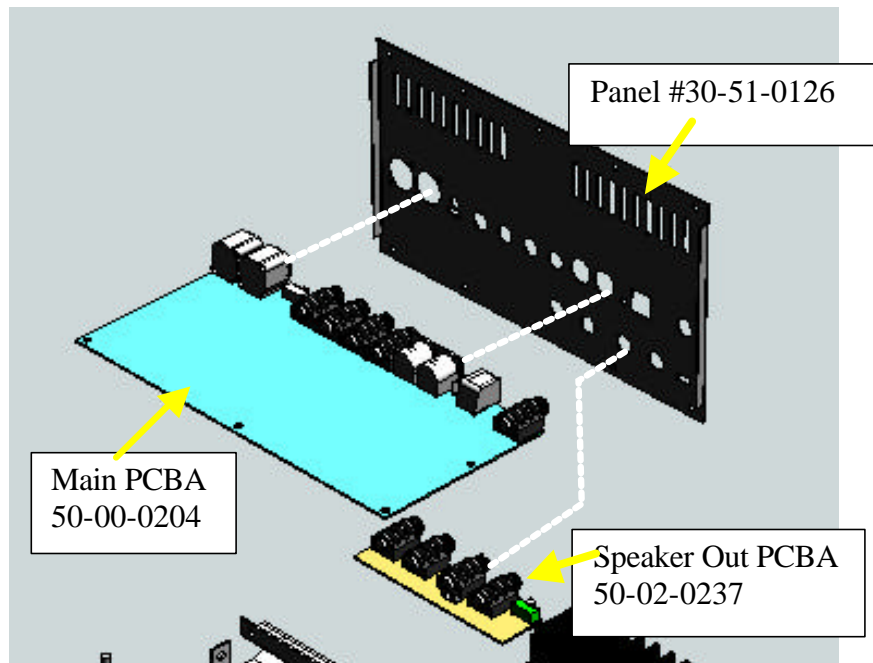

Main PCBA and Speaker Output PCBA mounting

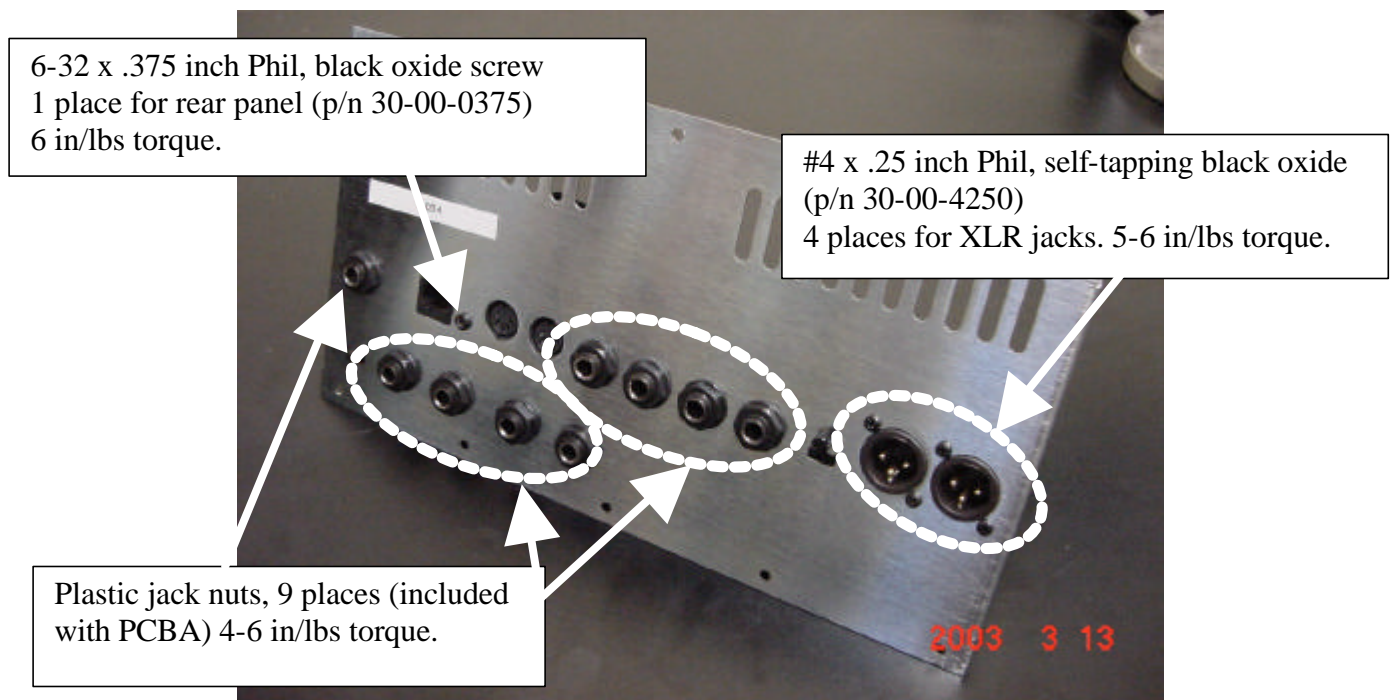

6-32 x .375 inch Phil, black oxide screw
1 place for rear panel (p/n 30-00-0375)
6 in/lbs torque.

#4 x .25 inch Phil, self-tapping black oxide
(p/n 30-00-4250)
4 places for XLR jacks. 5-6 in/lbs torque.

Plastic jack nuts, 9 places (included
with PCBA) 4-6 in/lbs torque.

Completed Rear Panel Assembly – top view

LINE 6
Engineering

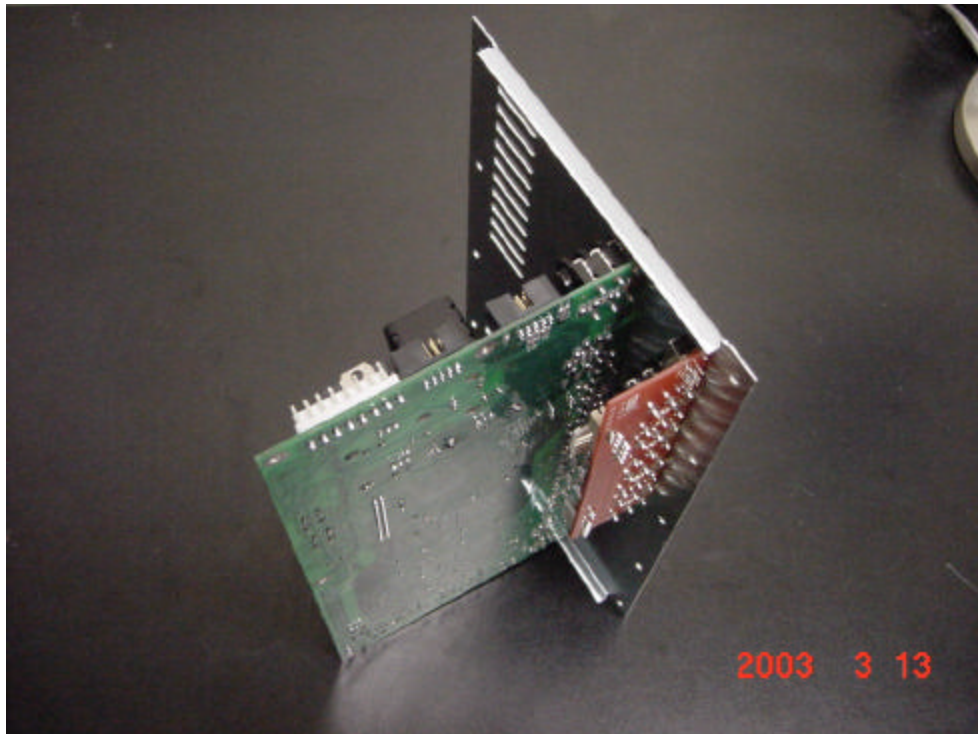

Completed Rear Panel Assembly – end view

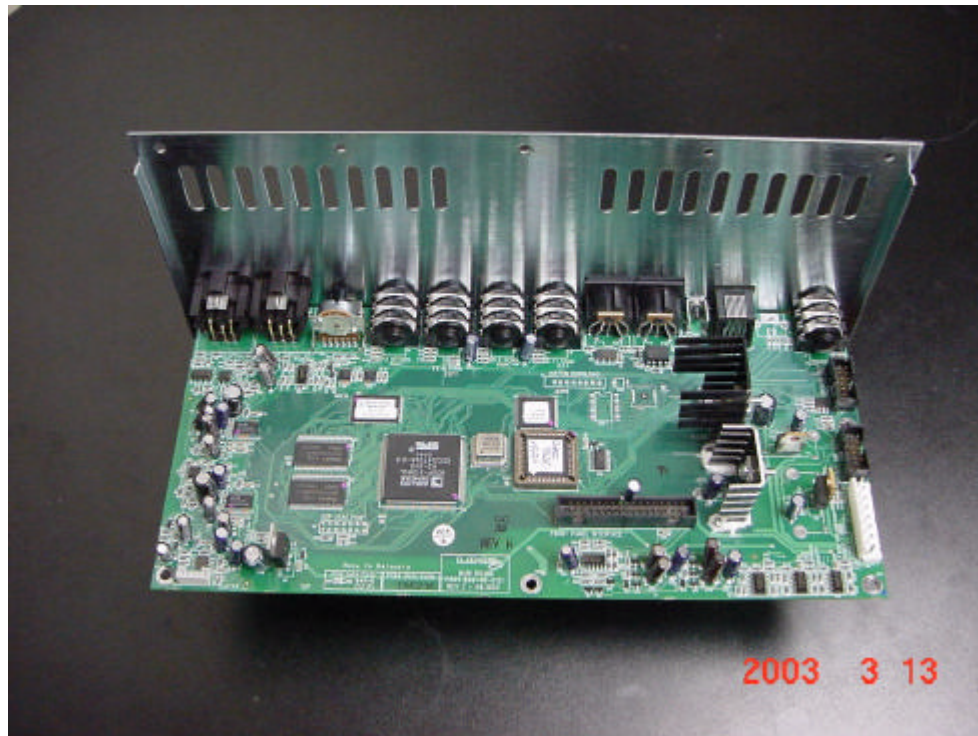

Completed Rear Panel Assembly – rear view

9) Rear panel assembly installation onto Base Chassis.

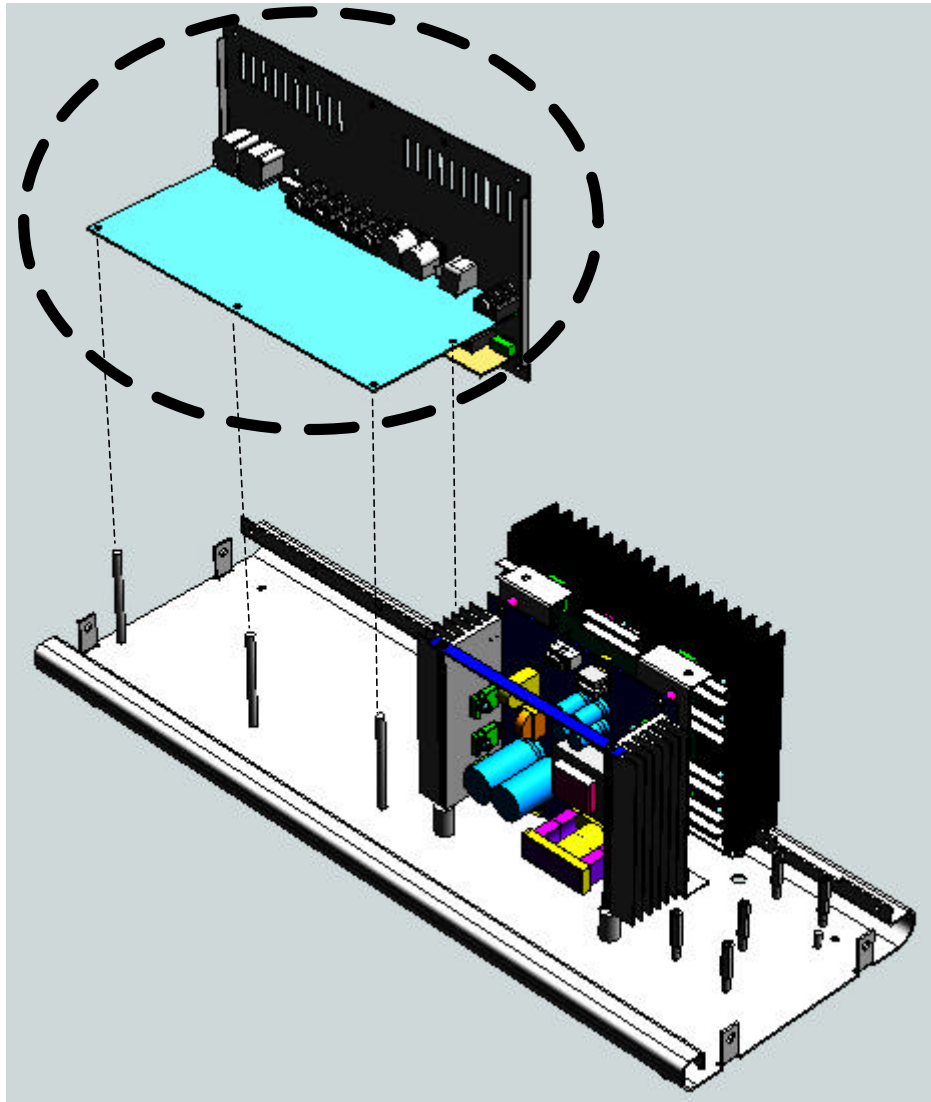

Rear Panel Assembly installation onto Base Chassis

LINE 6

Engineering

10) Connect Power Amplifier cables to Main PCBA and Speaker Output PCBA.

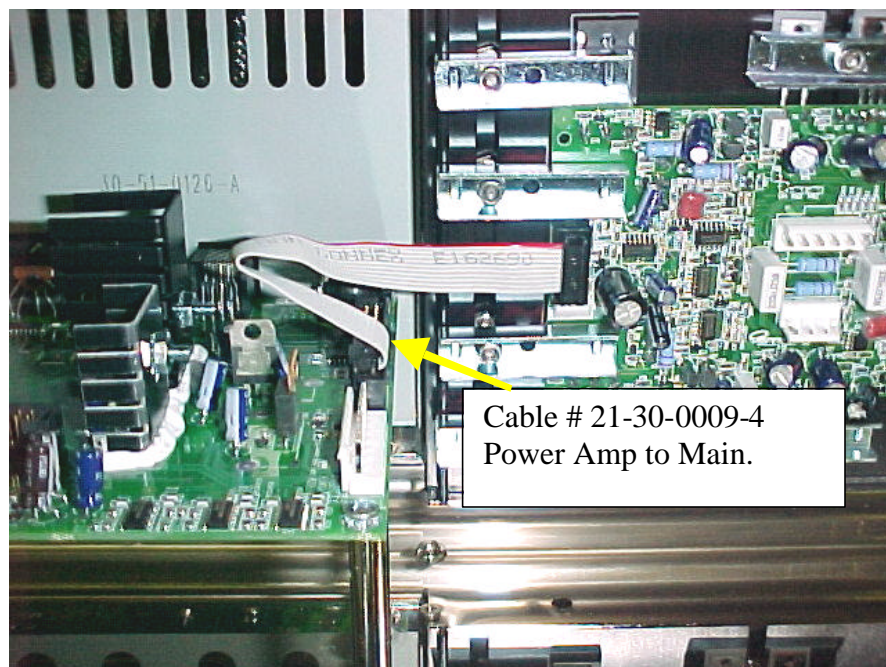
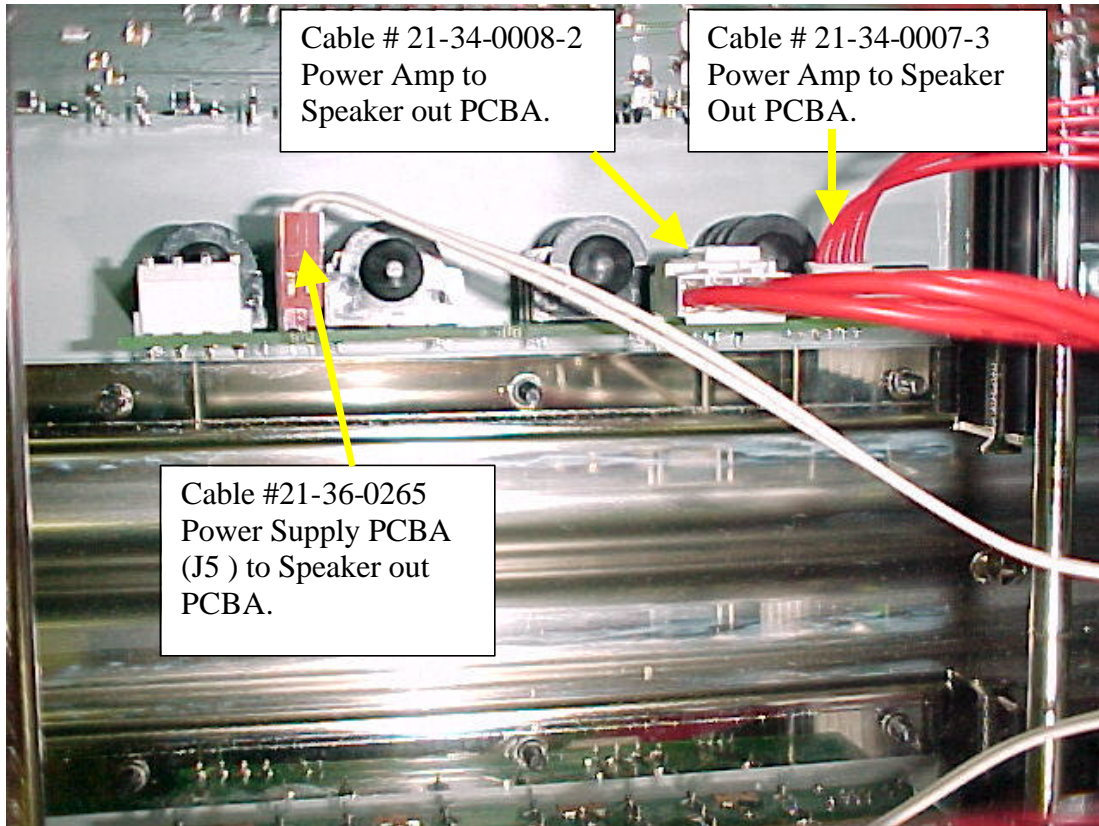

11) Secure MAIN PCBA with 4 each 6-32 screws (p/n 30-00-0607). Torque the screws to 8-10 in-lbs.

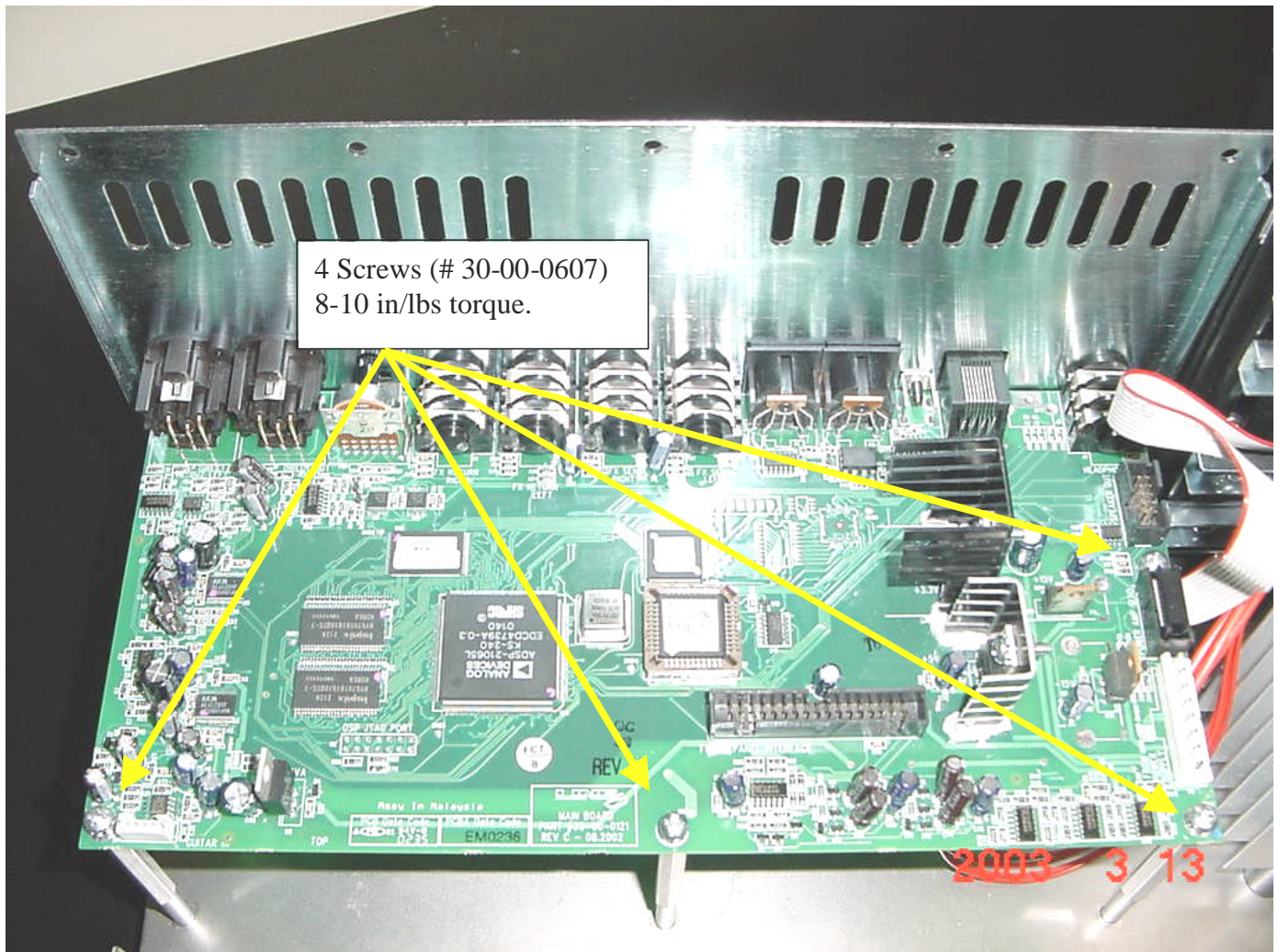

Main PCBA fastening to the Base Chassis

LINE 6

Engineering

12) **LOOSELY** install 5 each **BLACK SCREWS** (p/n 30-00-0375) to hold panel to chassis. These screws can be fully torqued down, when the Top Chassis is assembled.

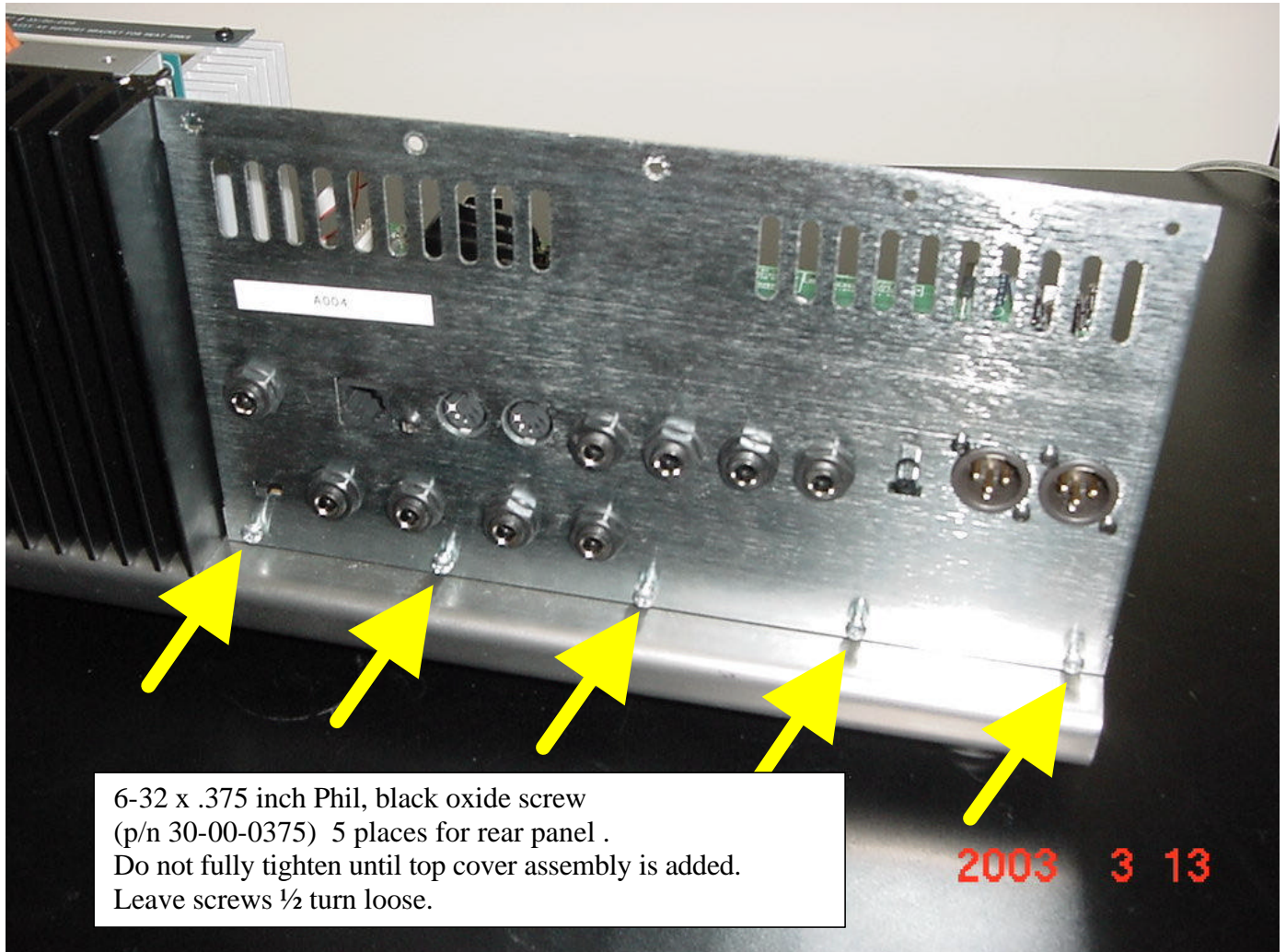

6-32 x .375 inch Phil, black oxide screw
(p/n 30-00-0375) 5 places for rear panel .
Do not fully tighten until top cover assembly is added.
Leave screws ½ turn loose.

13) Install POWER SUPPLY to MAIN PCBA CABLE ASSEMBLY (# 21-34-0014-2).
Route the cable around the back of the Power Supply Bracket as shown.

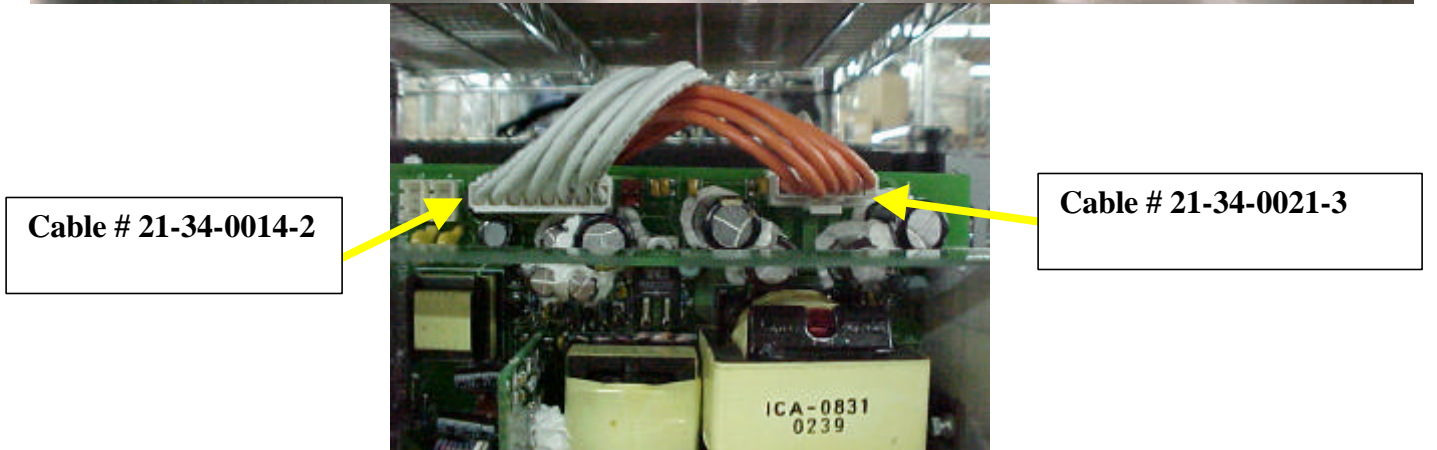
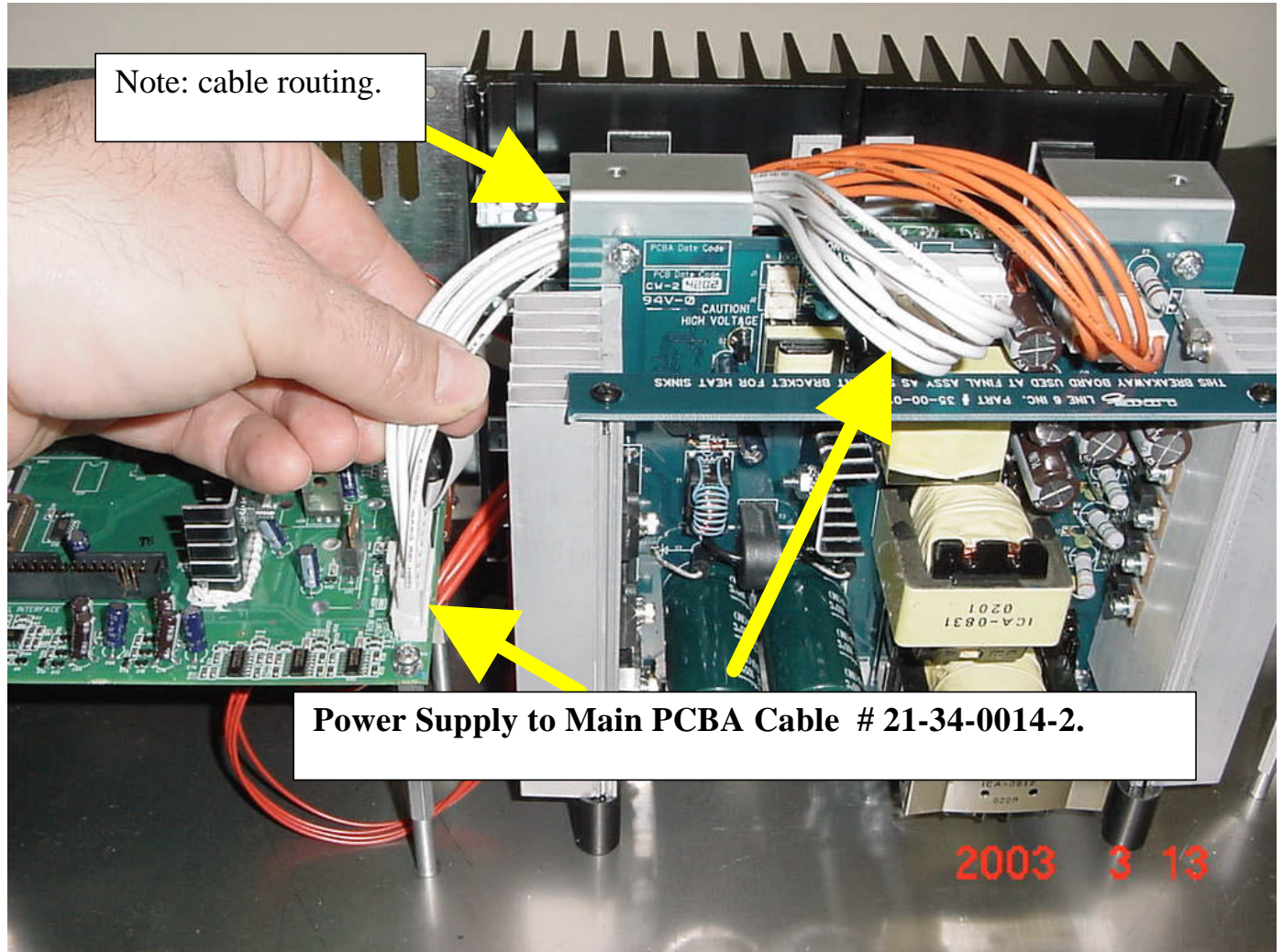

14) Install the LINE FILTER PCBA p/n 50-00-4001 into chassis.

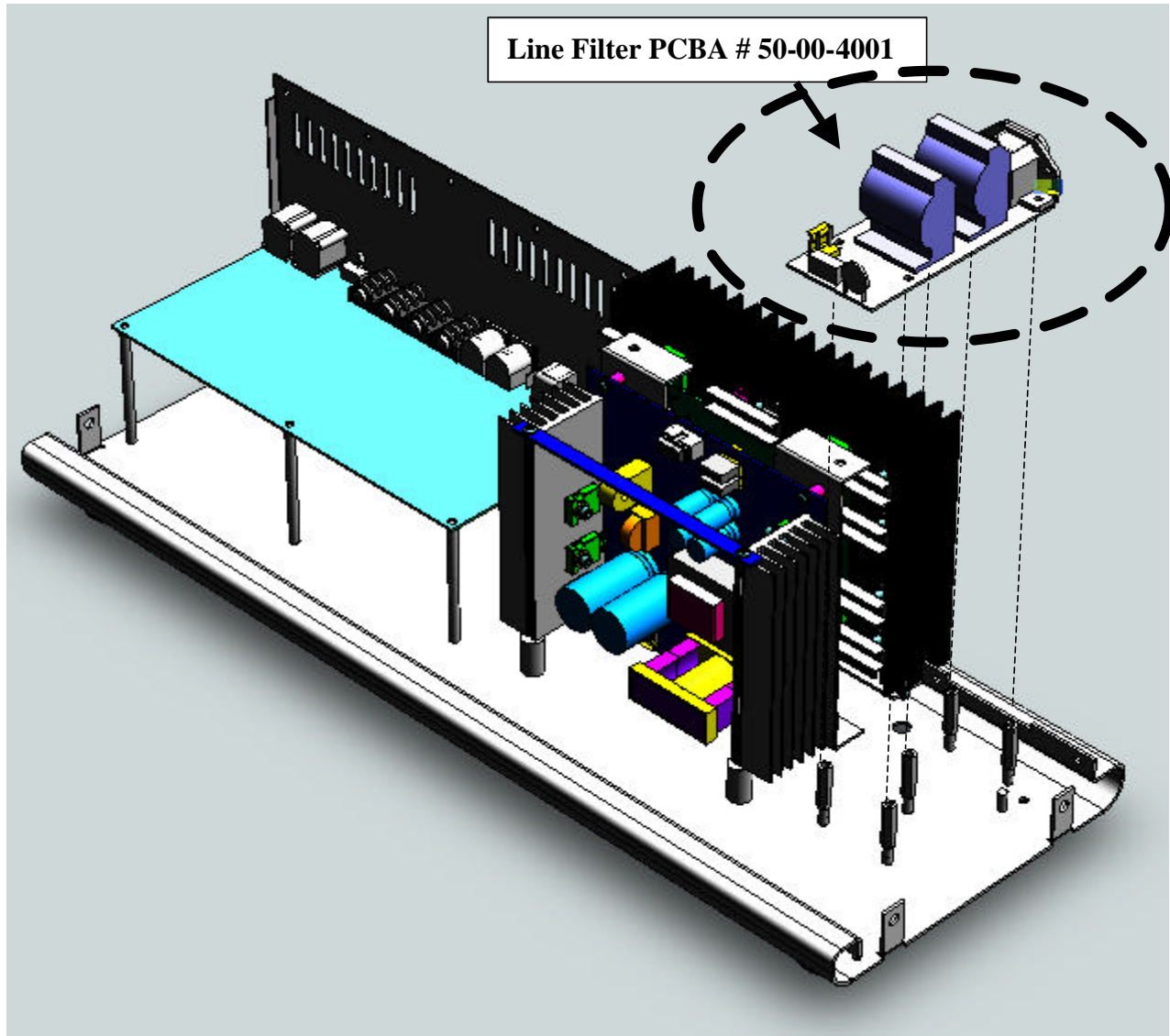

Line Filter PCBA Installation

LINE 6 Engineering

14a) Install the LINE FILTER PCBA p/n 50-00-4001 into chassis using 5 each 6-32 screws p/n 30-00-0607, to 8-10 in/lbs.
Attach AC receptacle ground wire to chassis standoff using 1 each 6-32 screws (p/n 30-00-0607).
Torque all screws to 8-10 in-lbs.

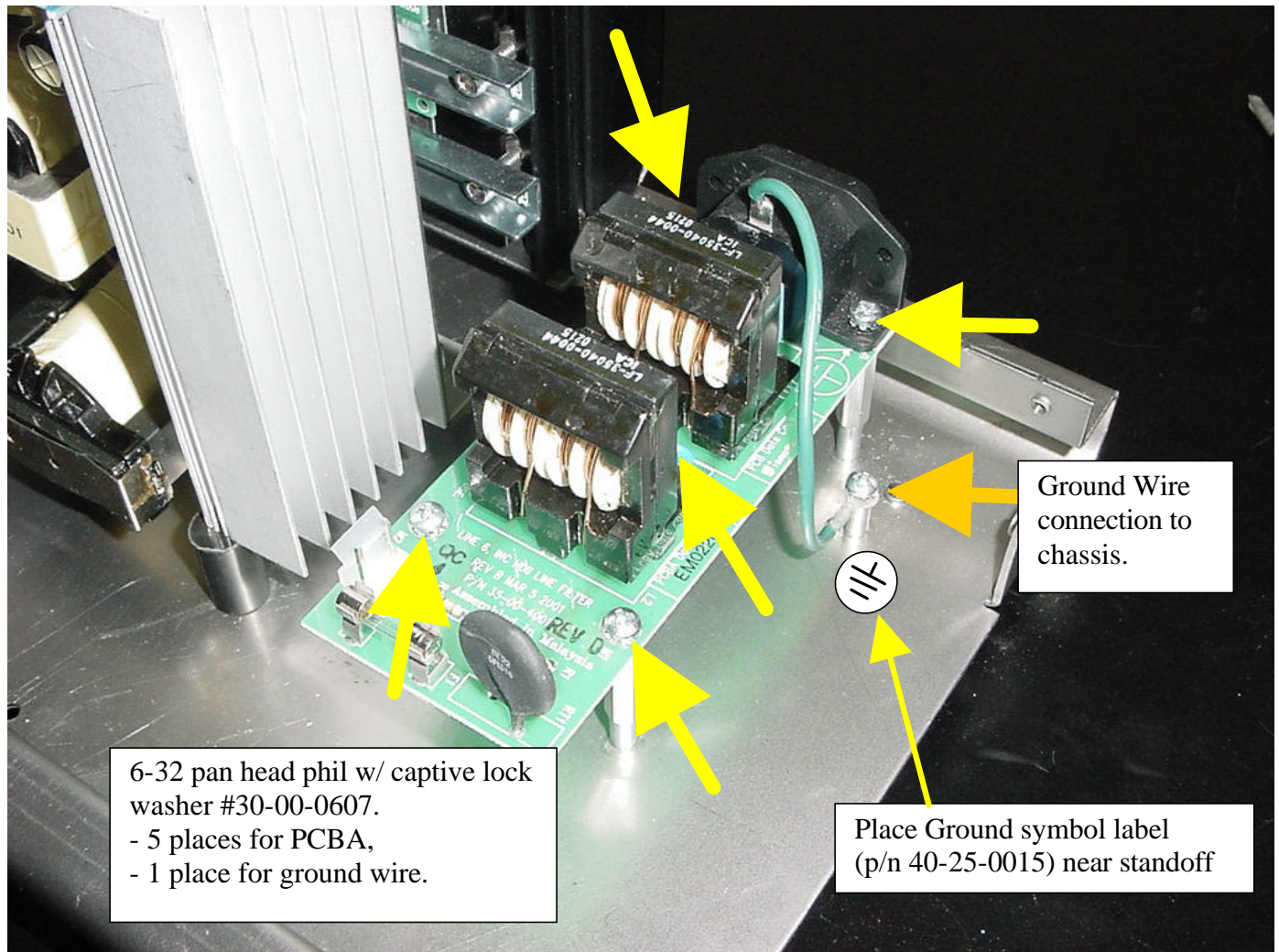

FUSES:

220/240v Units use #24-19-4250 4 amp 250v 5 x 20mm FRN

100/120v Units use #24-19-8250 8 amp 250v 5 x 20mm fast acting.

LINE 6

Engineering

15) Install the LINE FILTER PCBA to POWER SUPPLY cable assembly # 21-34-0018-1.

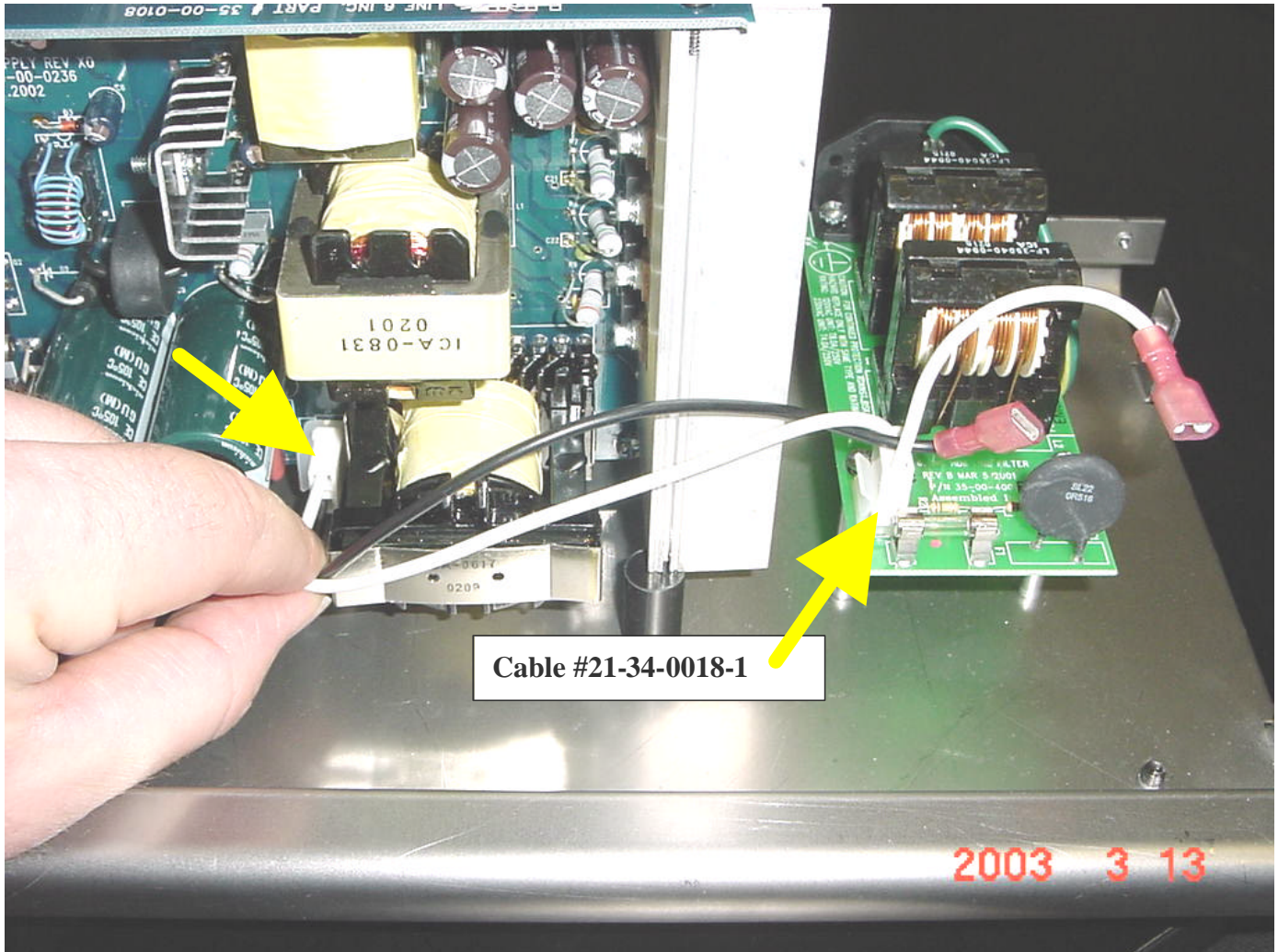



TOP CHASSIS SUB-ASSEMBLY

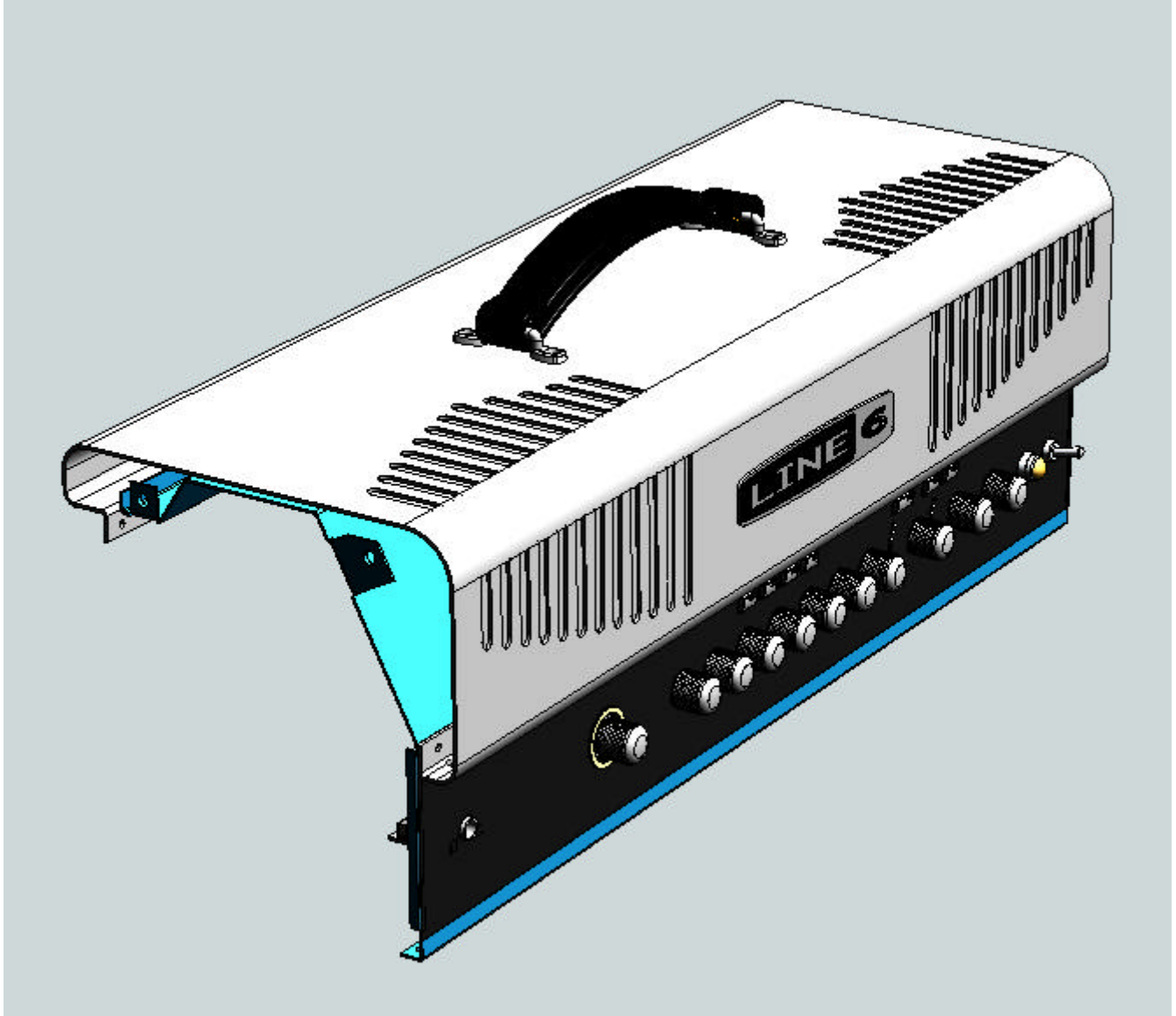

Full View - Front View - Top Chassis Sub Assembly

LINE 6
Engineering



Full View - Front View - Top Chassis Sub Assembly

LINE 6
Engineering

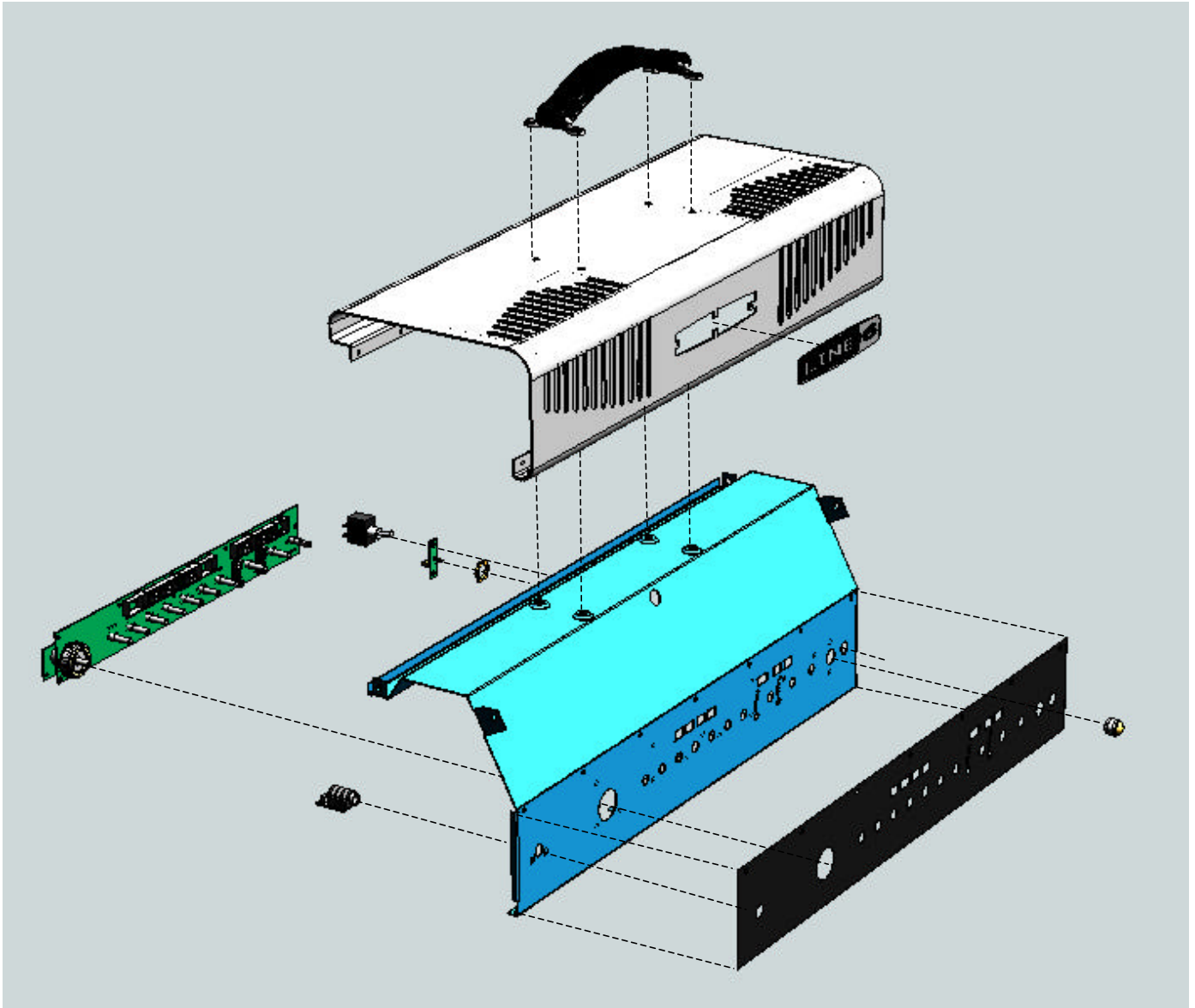

Exploded View - Main Components – Front-Left View - Top Chassis Sub Assembly

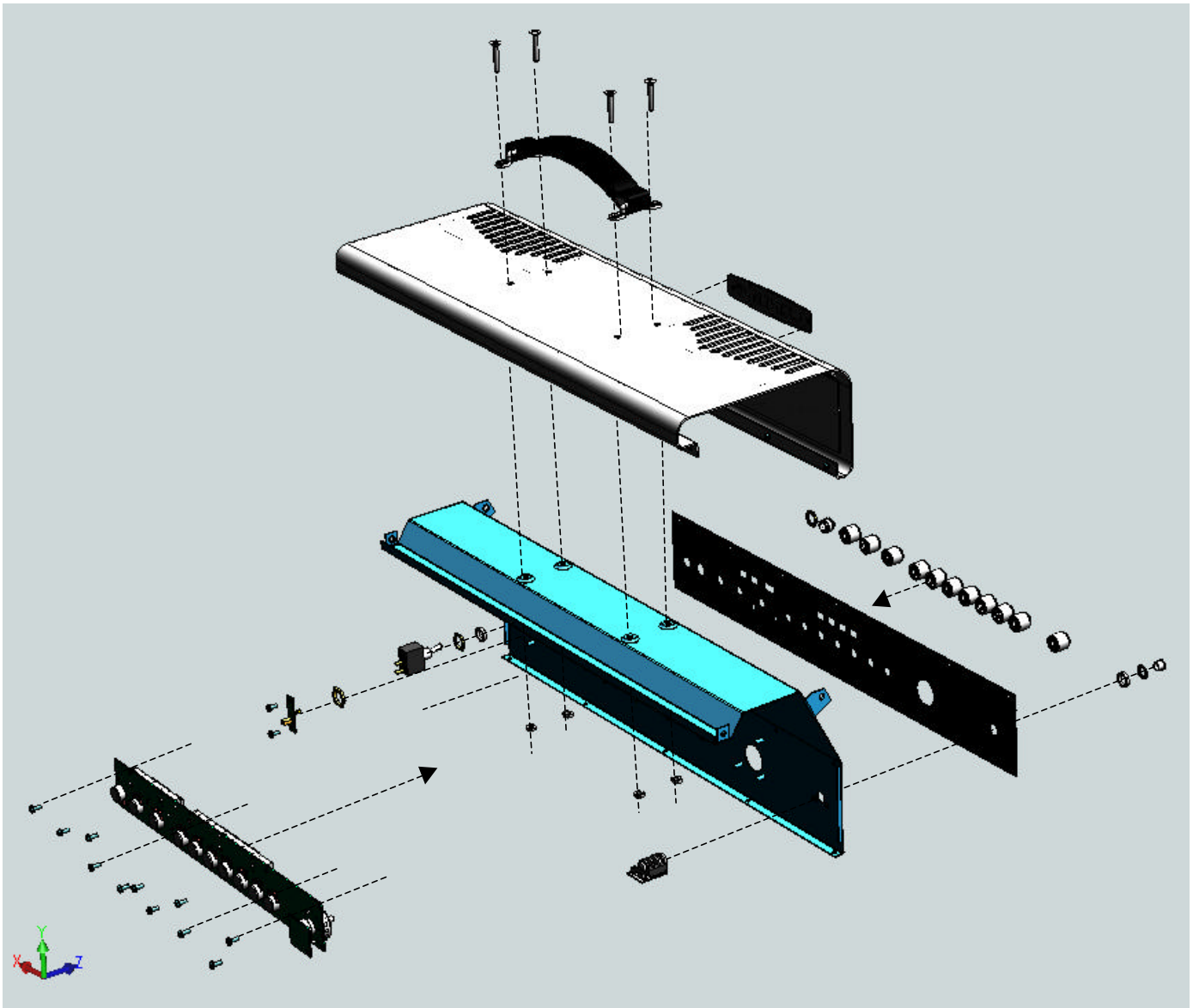

Exploded View - Main Components – Rear-Left View – Top Chassis Sub Assembly
(NOTE: LED PCBA 50-02-0008 is not shown)

LINE 6 Engineering

16a) # 50-02-0008 LED PCBA assembly to top chassis :

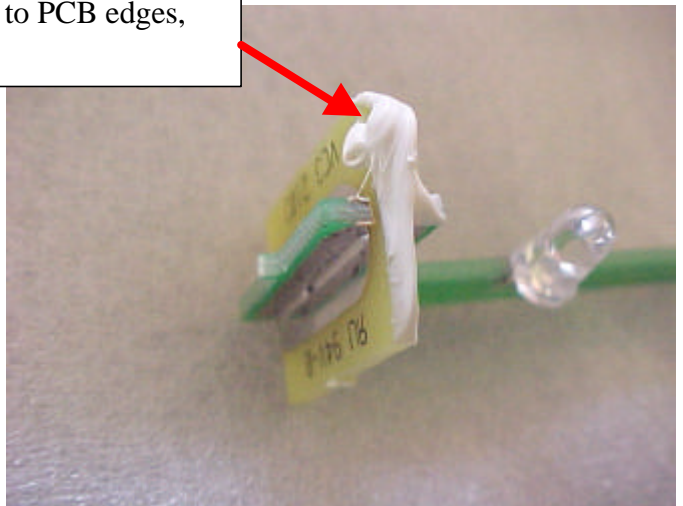
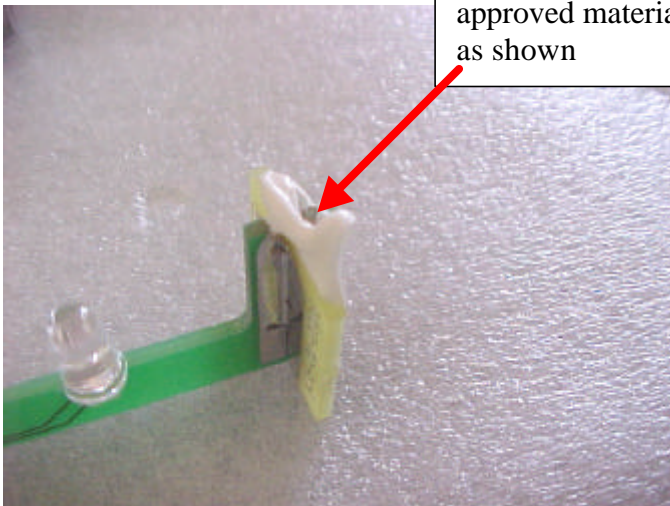
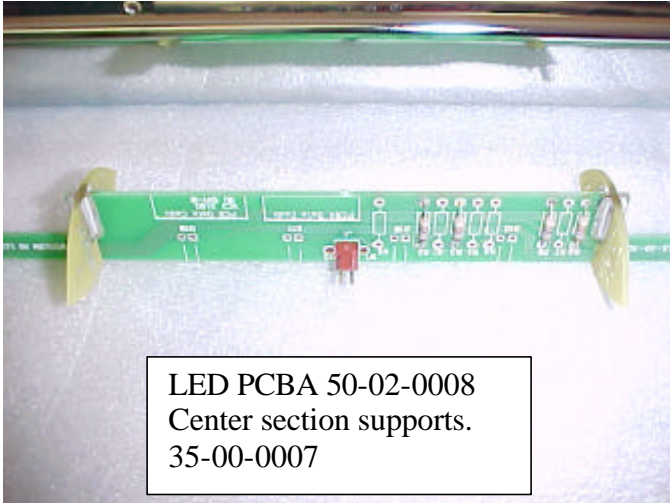

LINE 6

Engineering

16b) # 50-02-0008 LED PCBA assembly to top chassis cont. :

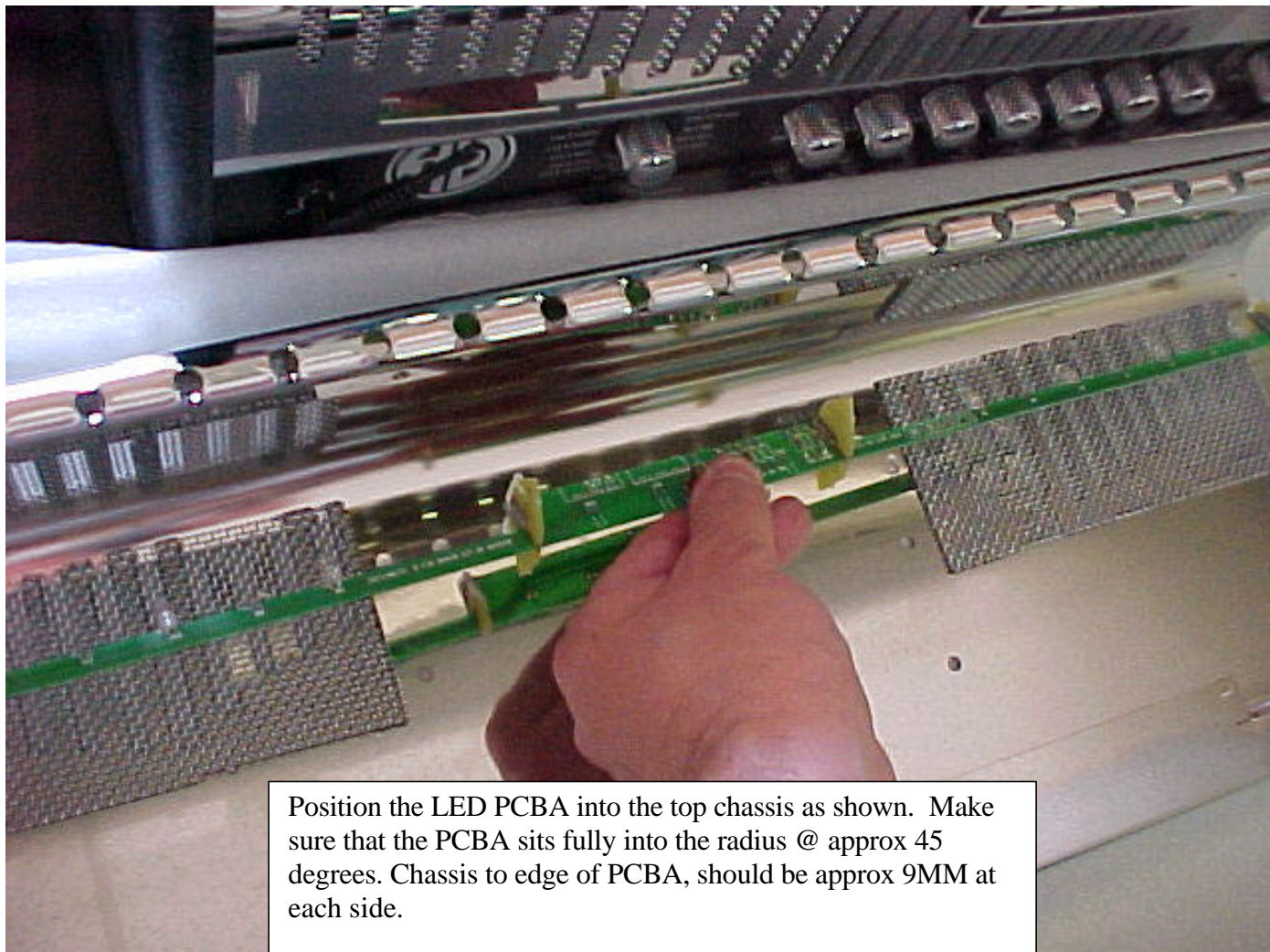

Position the LED PCBA into the top chassis as shown. Make sure that the PCBA sits fully into the radius @ approx 45 degrees. Chassis to edge of PCBA, should be approx 9MM at each side.

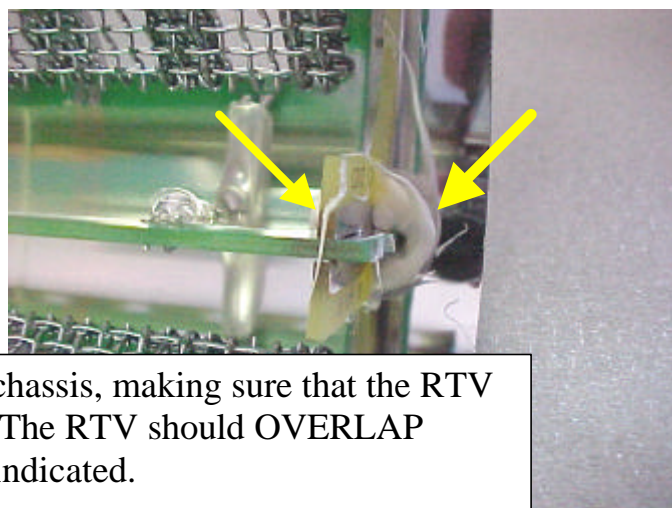
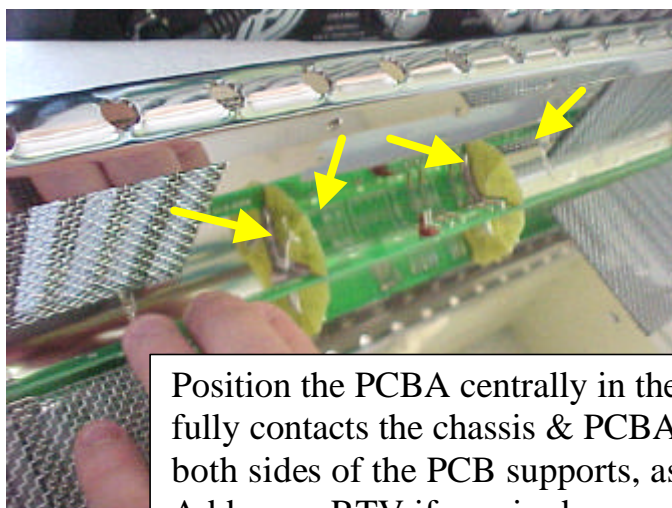

Position the PCBA centrally in the chassis, making sure that the RTV fully contacts the chassis & PCBA. The RTV should OVERLAP both sides of the PCB supports, as indicated. Add more RTV if required.

16c) # 50-02-0008 LED PCBA assembly to top chassis cont. :

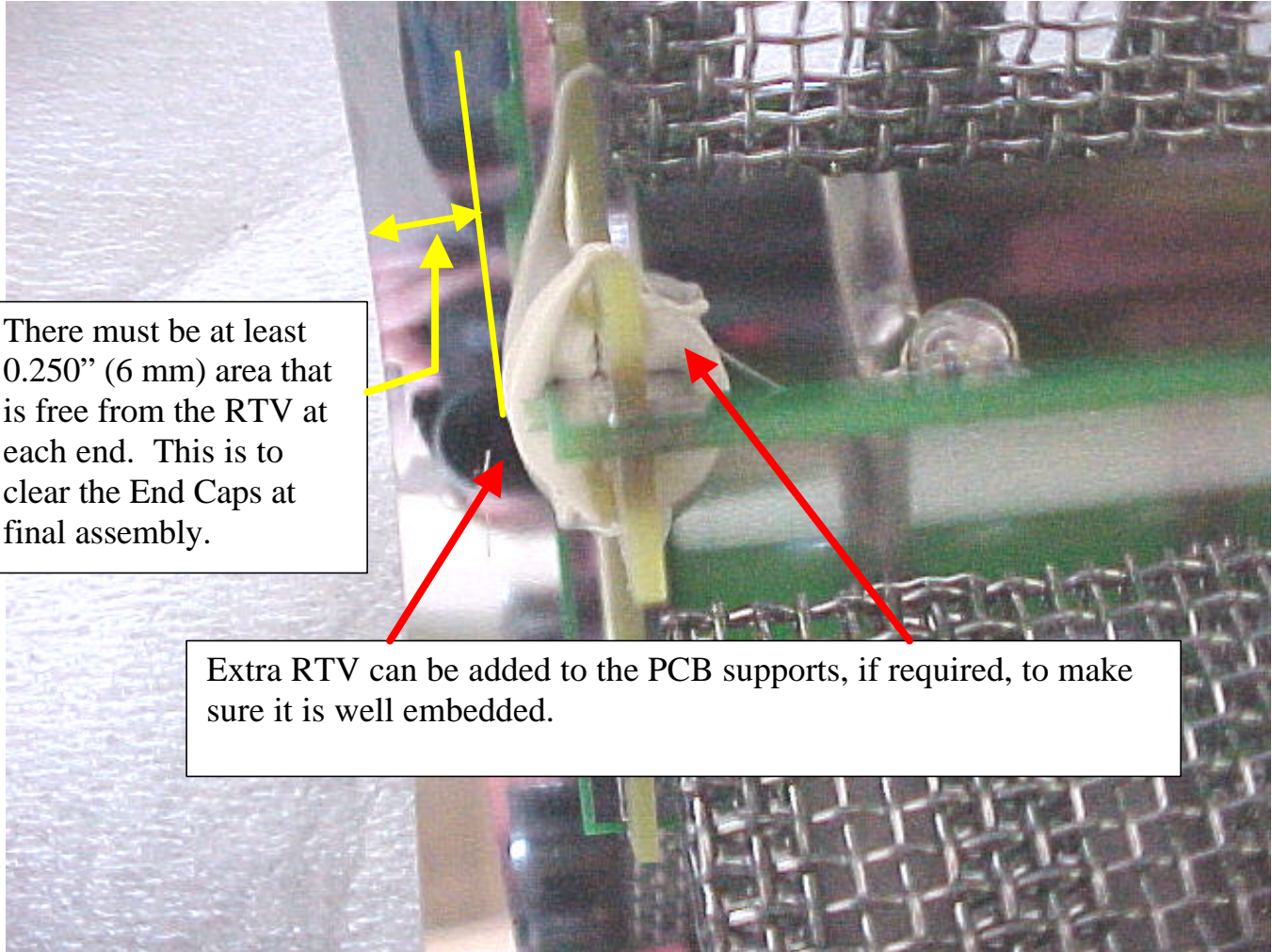

There must be at least 0.250" (6 mm) area that is free from the RTV at each end. This is to clear the End Caps at final assembly.

Extra RTV can be added to the PCB supports, if required, to make sure it is well embedded.

□

NOTE : Set the Chassis aside & allow a minimum of 20 minutes, for the RTV to cure, before assembling the Shield (30-51-0070).

Check that the LED PCBA is still in the correct position, and hasn't moved. If the LED PCBA has moved, then it should be re-positioned.

- **Attach Cable #21-36-0265 on to LED PCBA (J1)**

LINE 6

Engineering

Assemble parts onto the sheet metal SHIELD.

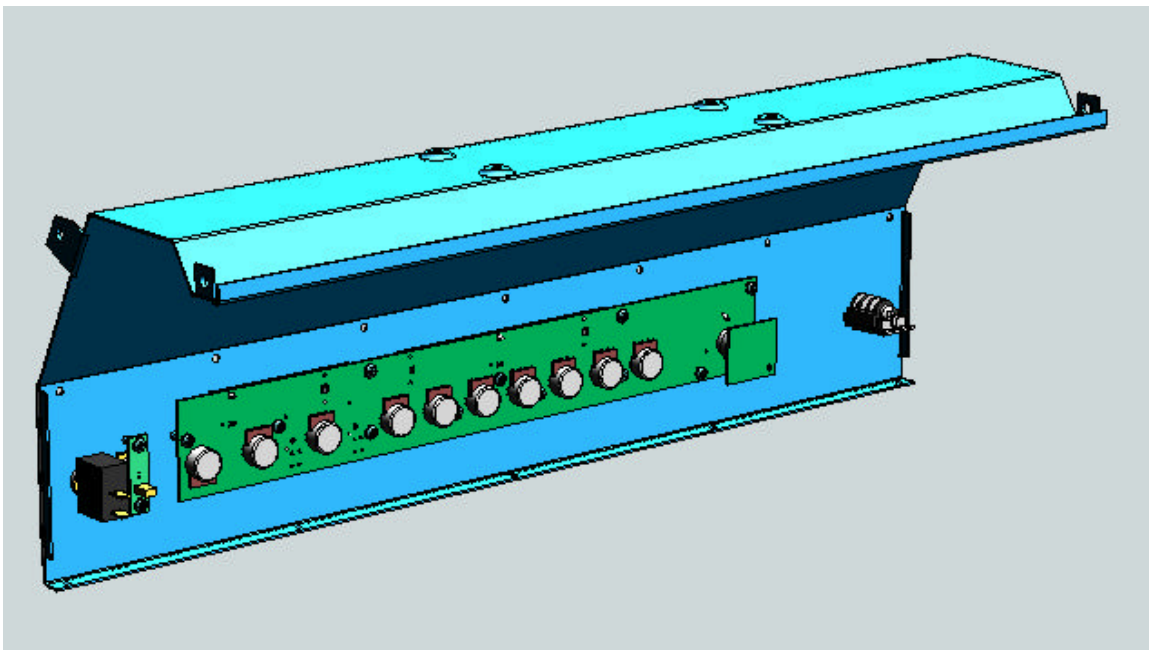
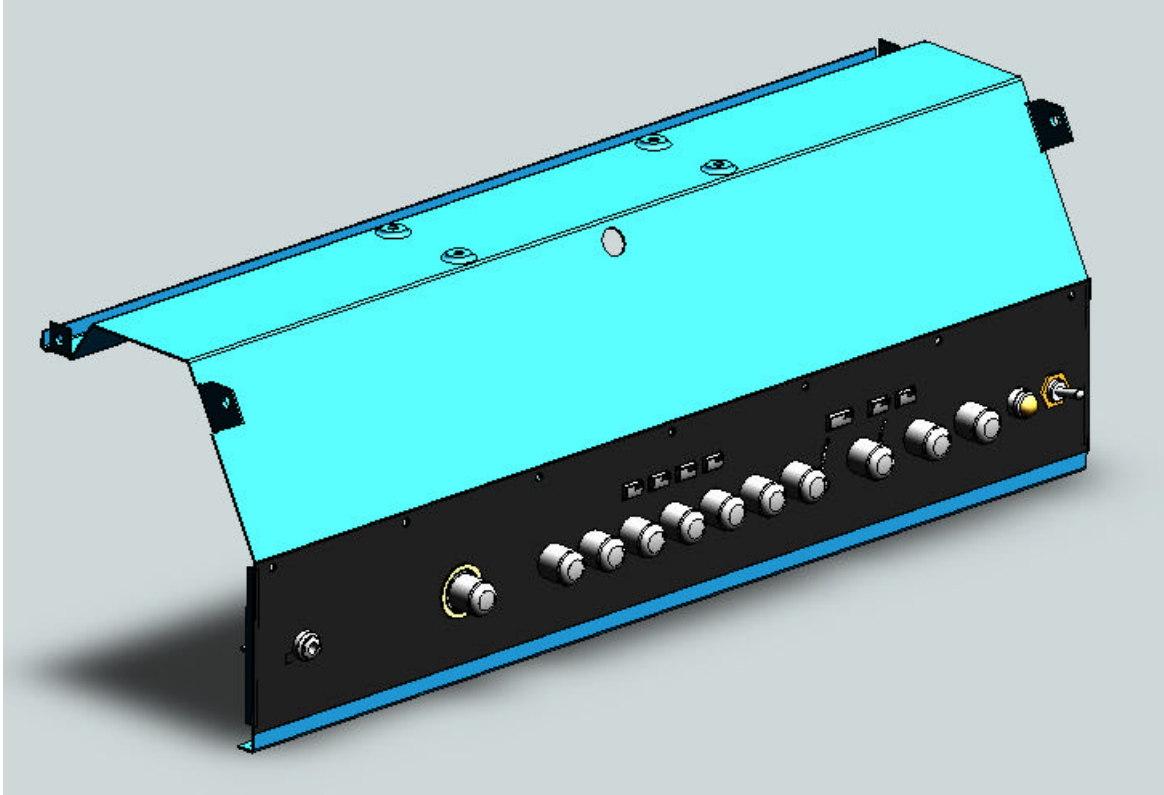

LINE 6

Engineering

17) Install OVERLAY (# 30-51-0137) onto SHIELD (# 30-51-0070). Remove self-adhesive cover paper, align to SHIELD holes and firmly press overlay onto the SHIELD front face as shown. An alignment fixture is recommended, to assure accurate alignment of the holes.

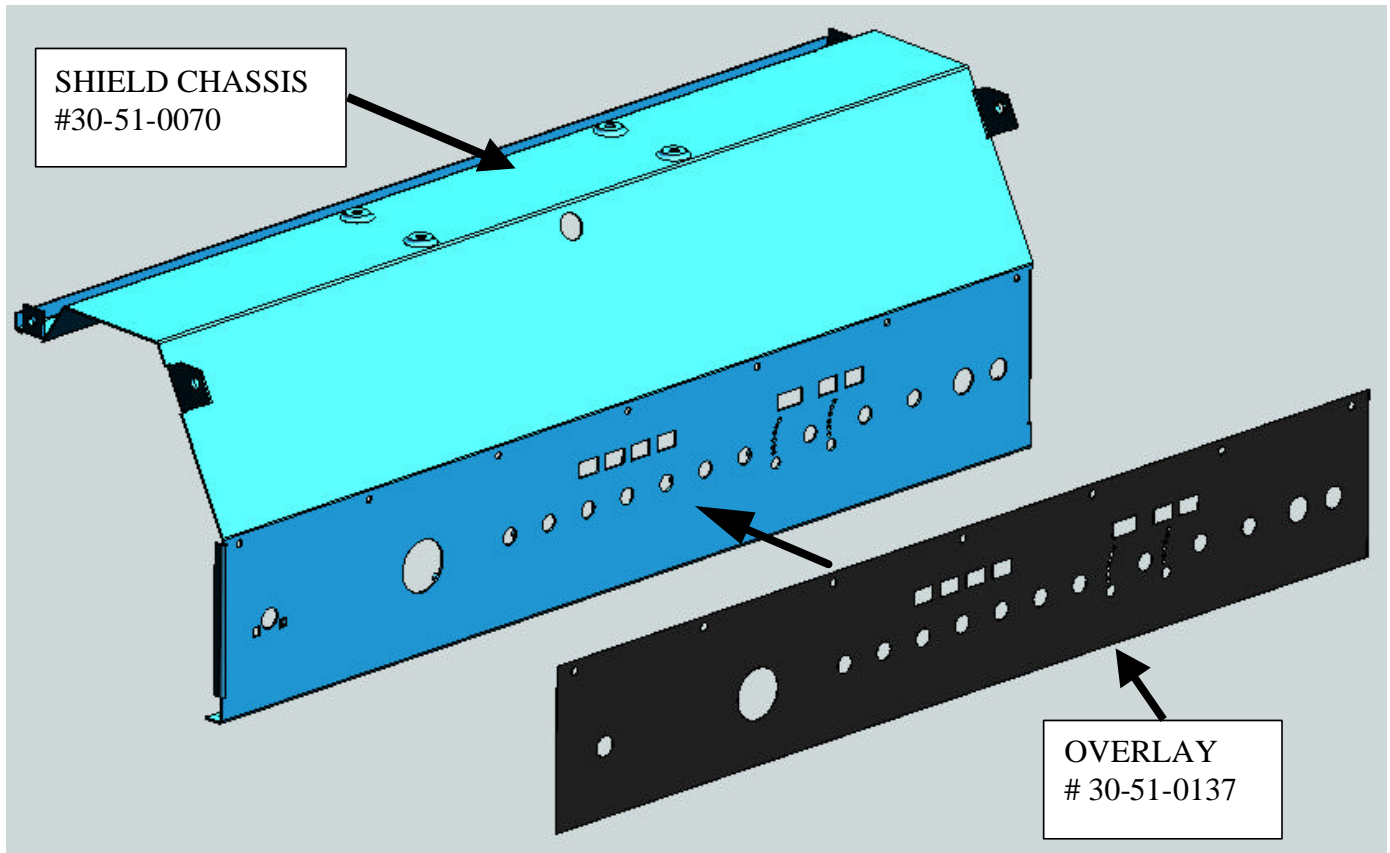

18) Install USER INTERFACE PCBA (# 50-02-0146) onto SHIELD.

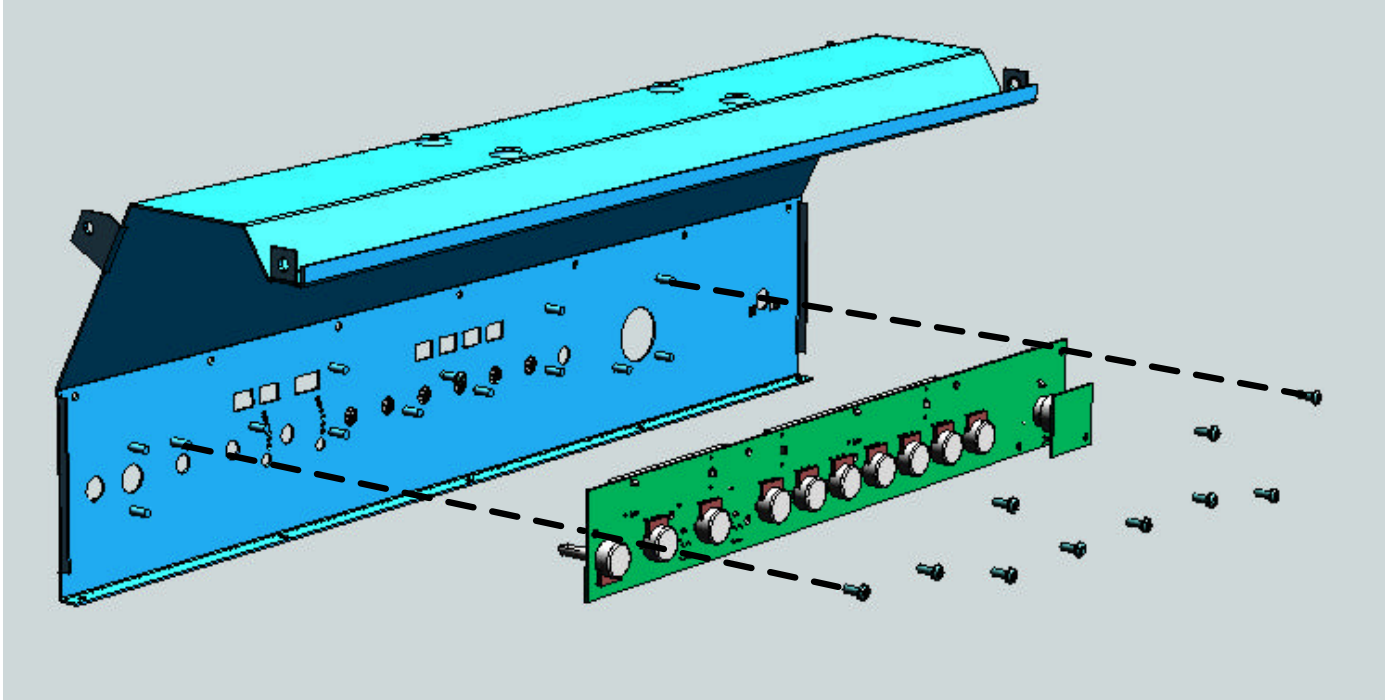

SHIELD / USER INTERFACE PCBA – exploded view

LINE 6

Engineering

18a) To Assemble the UI front panel PCBA.

- 1) Inspect the UI front panel (50-02-0146) and ensure all pots, encoders, LED's and tack switches are soldered flat to the PCB surface. Inspect for concentricity for shafts with the silkscreen artwork.
- 2) Apply the spacer washer (#30-15-0014) over the shaft and pass the encoder through the circular cutout (see figure). Before finger snug the nut and washer on the encoder and check that (1) the shaft of the encoder is concentric with the though hole and that (2) the corner 6-32 screw clearance holes between the front panel and breakaway are concentric (see below). Finish tightening nut to 6-8 inch-lbs.

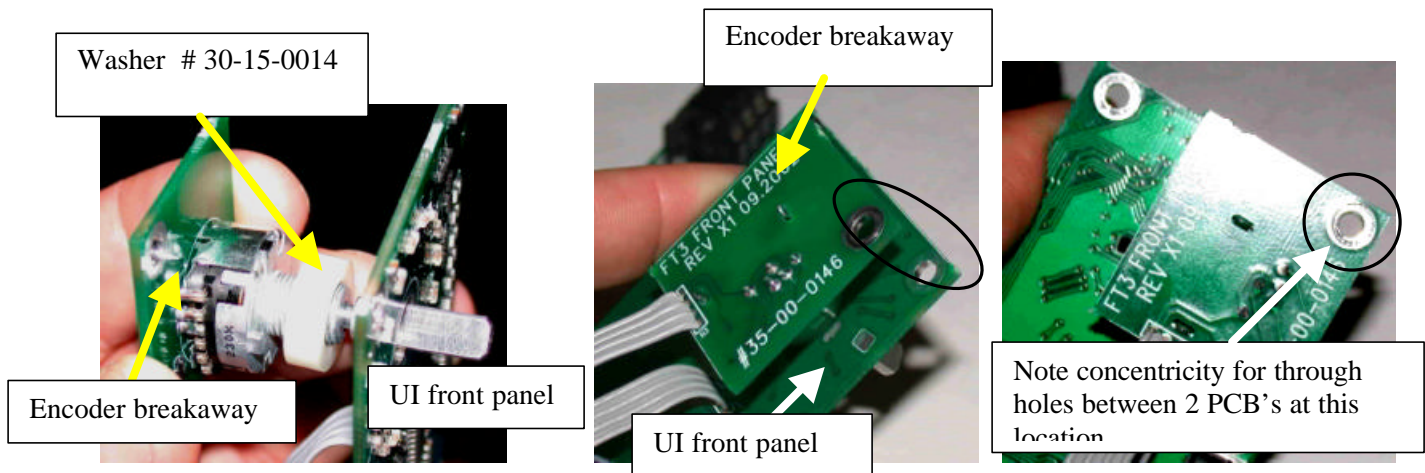

- 3) Heat stake the 2 light pipes (30-27-0060) to the front panel at the though holes adjacent to the 2 tack switches (see figure below left). Ensure that the shafts of the light pipes perpendicular to the PCBA board while securing in place (see figure below).

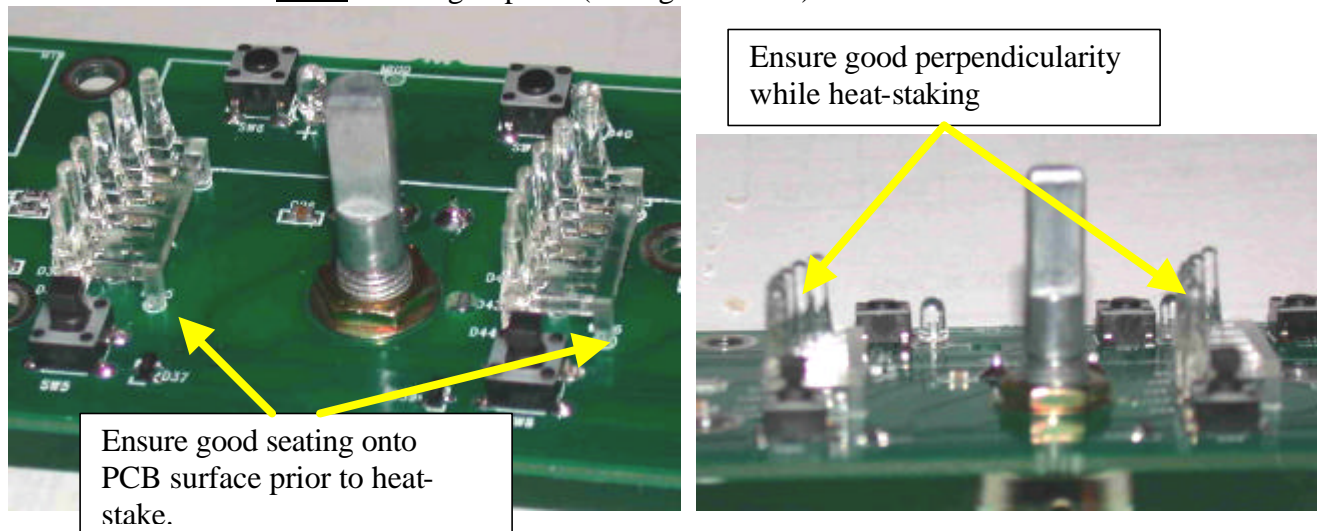

LINE 6 Engineering

- 4) Clip the indicated keycaps and framing from the switch cap (24-21-1122). Install on the front panel at position M1.

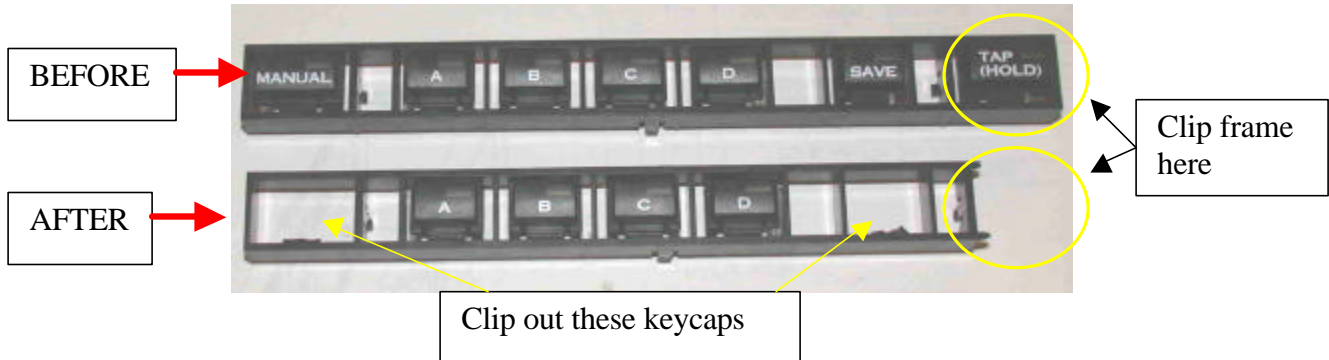

- 5) Clip the indicated keycaps and framing from the assy art switch cap (50-00-0238) and install on the front panel as indicated below.

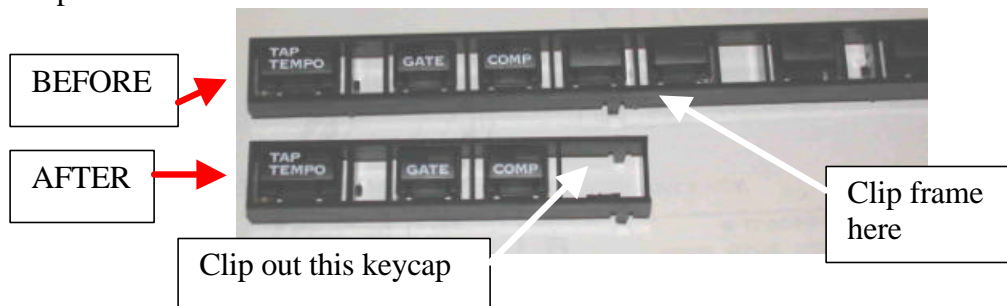

- 6) Install the 2-shot light pipe (30-27-0049) over the main encoder. Check that the part is fully clipped onto the panel and does not sit on any of the LED's. Also confirm that it sits concentric with the opening.

If it does not, remove the light pipe, loosen the hex nut and adjust the concentricity of the shaft to match the silkscreen hole. Re-install the light pipe and confirm concentricity.

LINE 6

Engineering

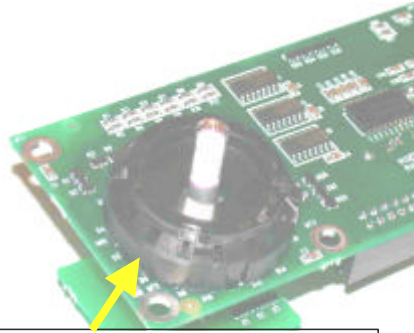

30-27-0049 Lightpipe.

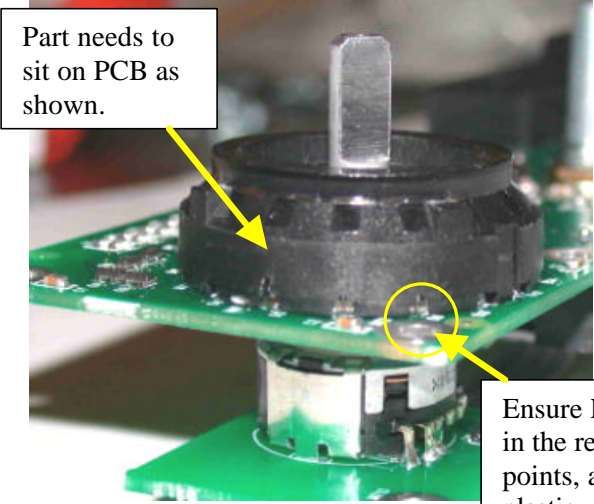

Part needs to sit on PCB as shown.

Ensure LED's are in the recess points, and not on plastic.

LINE 6

Engineering

c) Install the User Interface PCBA and guitar input PCBA to the chassis cover.

- 1) Immediately prior to installing the UI PCBA (35-00-0146) to the chassis cover, install the 2 plastic select buttons (30-27-0061) onto the tack buttons on the UI front panel as shown below. (NOTE: these do not clip in and can come loose before installation – do not tip the panel as the buttons may fall off).

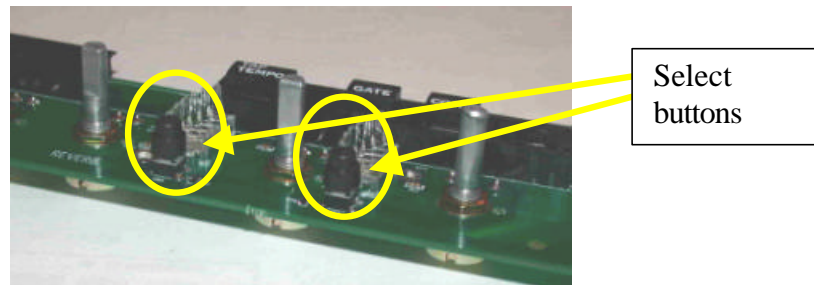

- 2) Install the UI front panel into the chassis cover without inverting the PCBA (see below). Ensure that the light pipes, select buttons and switch caps protrude without interference. Ensure that the encoder light pipe protrudes through overlay and sits about .020 inch over the surface.

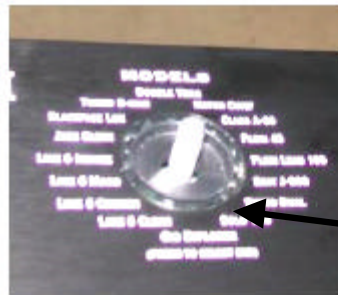
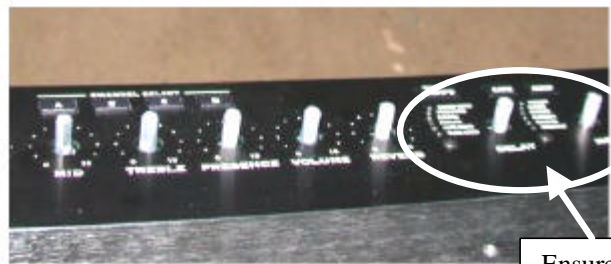

- 3) Secure the front panel to the chassis cover using 11 Screws 6-32 PHPS (30-00-0607) at the locations indicated. Secure and align the breakaway PCB using the long spacer (30-15-0016) and 1 inch long 6-32 PHPS (30-00-0035). Tighten the 1-inch screw to only 4 inch-lbs max.

LINE 6

Engineering

Secure the PCBA with eleven 6-32 captured lock-star pan head Phillips (30-00-0607) as shown.
Torque 8-10in/lbs.

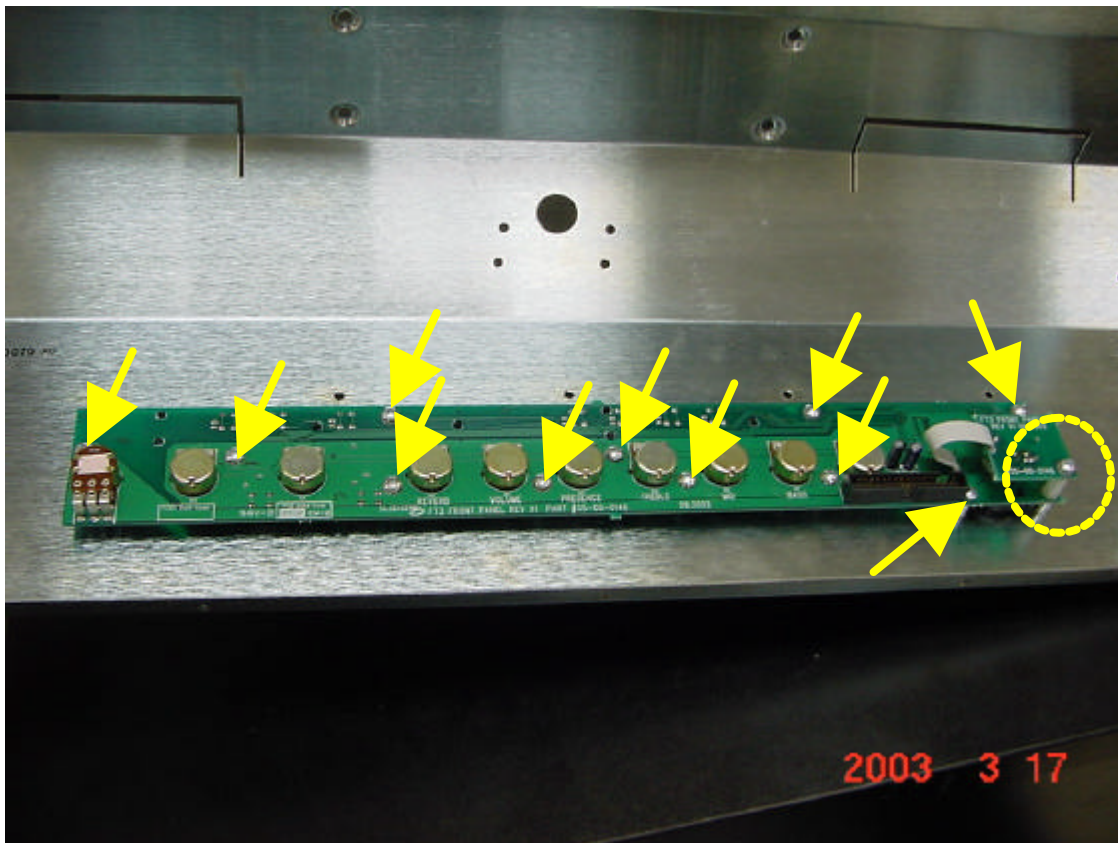

USER INTERFACE PCBA Installation

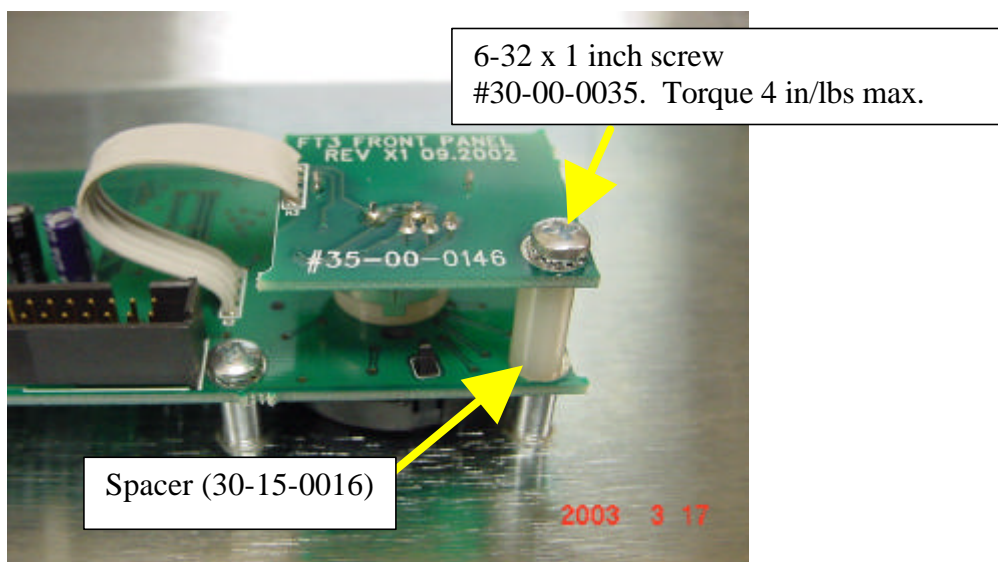

USER INTERFACE Light Pipe and Encoder PCBA Installation

LINE 6

Engineering

Inspect to see that the light pipe is sitting flush or slightly above the sheet metal (see figure below). If the light pipe sits below the sheet metal, loosen the screws, reset the front panel until the light pipe is seated and then tighten the screws.

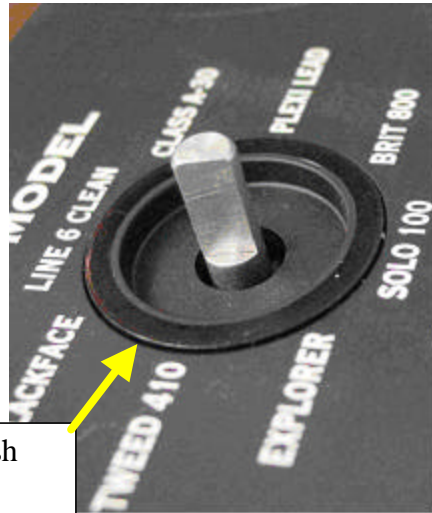

Note that the edge of light pipe is flush or slightly above the OVERLAY.

g) Install Guitar input jack PCBA (# 50-00-0169) onto SHIELD

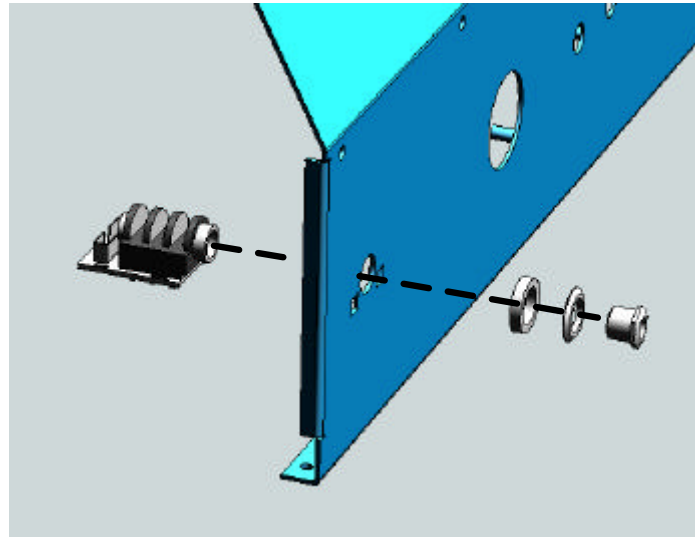

When positioned, secure the jack from the front face first installing a black spacer (30-15-0004), followed by an included black plastic corner washer and secured with the nickel finishing nut (included with the PCB assembly). Torque 6 in/lbs.

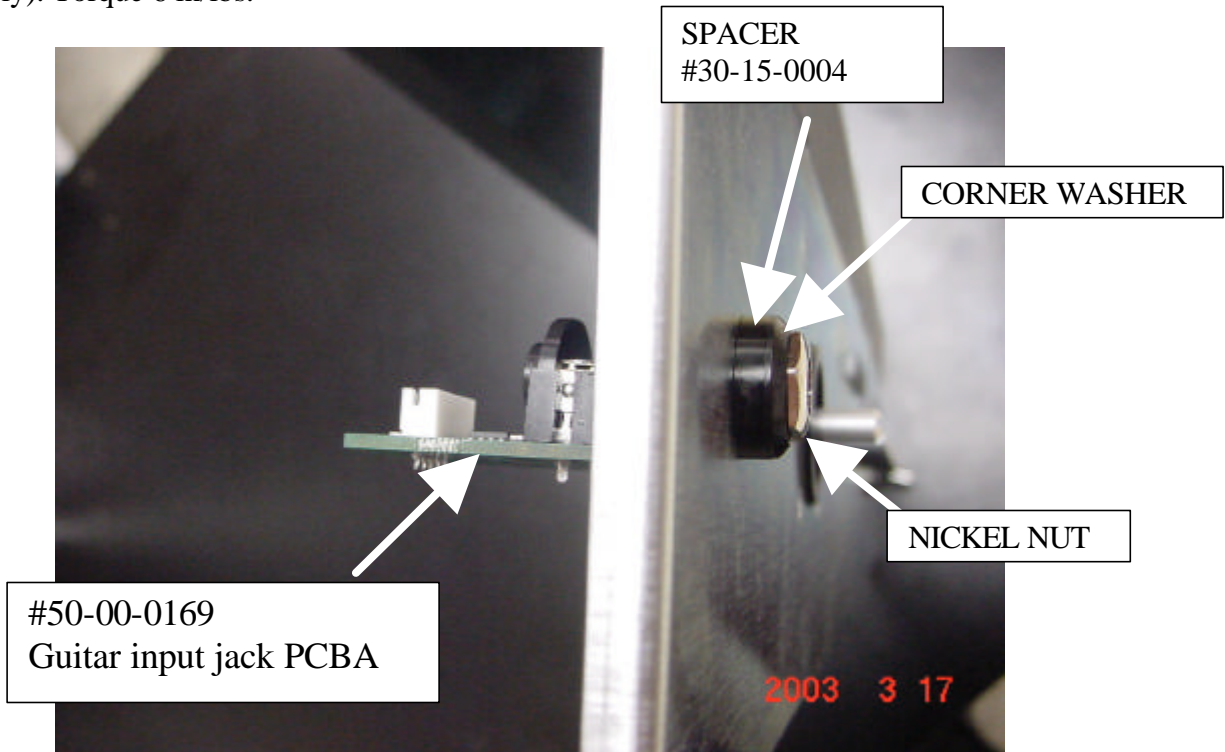

LINE 6

Engineering

f) Install JEWEL LENS # 30-51-0113 & Install LED PCBA # 50-02-0146 .

Secure the PCBA with two 6-32 captured lock-star pan head Phillips (30-00-0607) as shown. Torque 6 in/lbs.

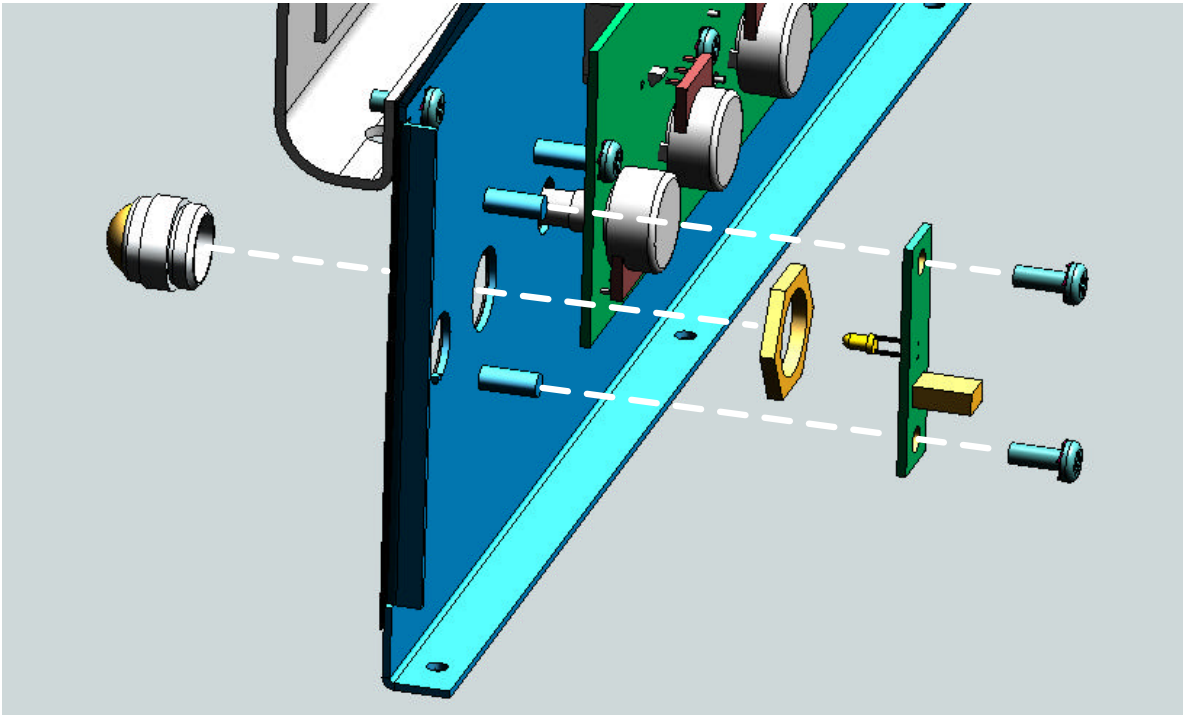

JEWEL LENS and LED PCBA – exploded view

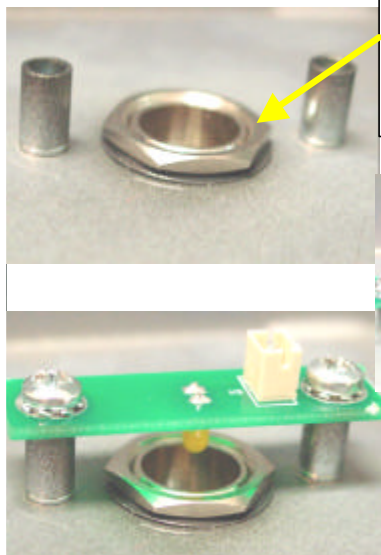

Use supplied nut and wave washer (30-03-0015).
Torque 6 in/lbs

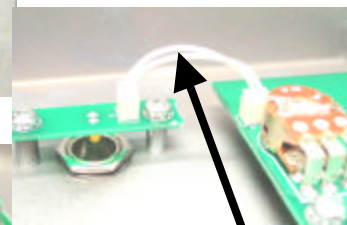

Cable for breakaway.
21-34-0030

LINE 6 Engineering

g) Install POWER SWITCH (# 24-03-0002) into SHIELD.

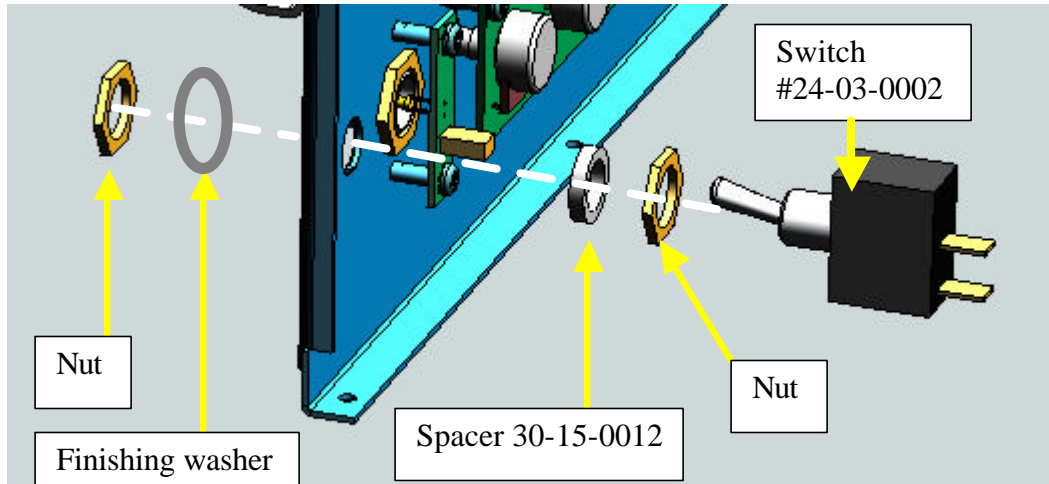

POWER SWITCH - exploded view

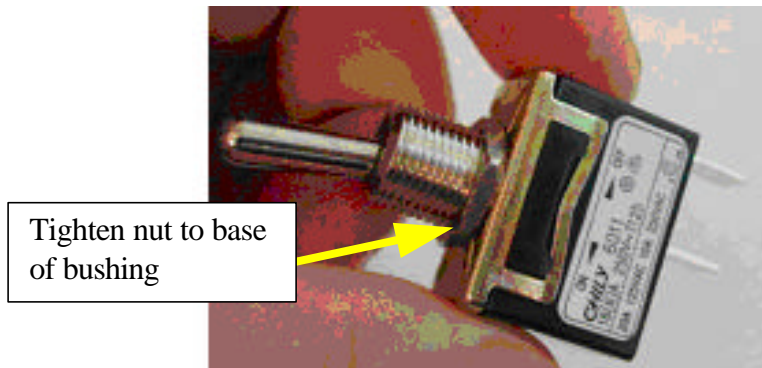

Tighten nut to base of bushing

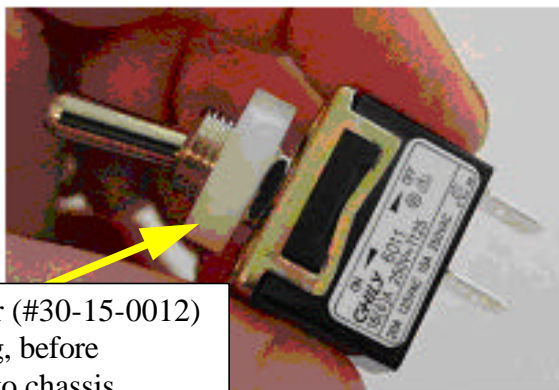

Place spacer (#30-15-0012) onto bushing, before installing into chassis.

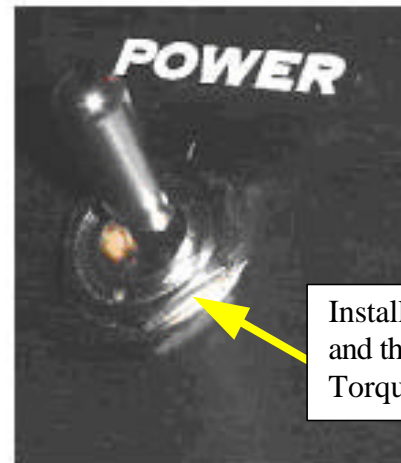

Install finishing washer and then hex nut. Torque 6 in/lbs

POWER SWITCH (#24-03-0002) hardware detail

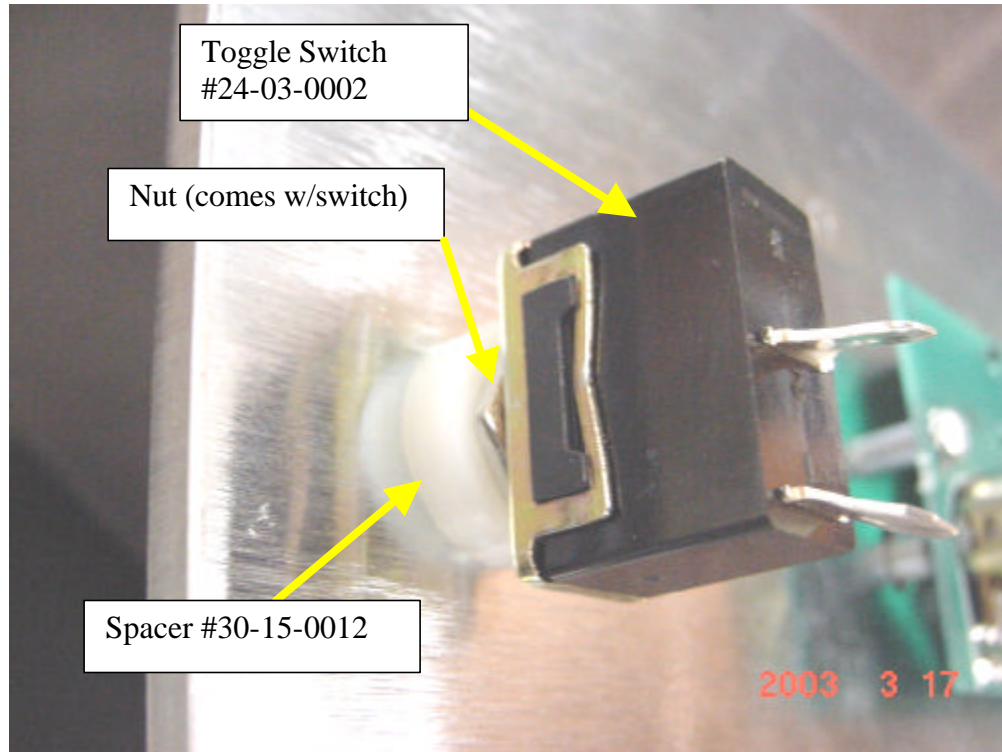

POWER SWITCH installation – rear view

g) Assembly of the Top Chassis(# 30-51-0125) and Shield subassembly.

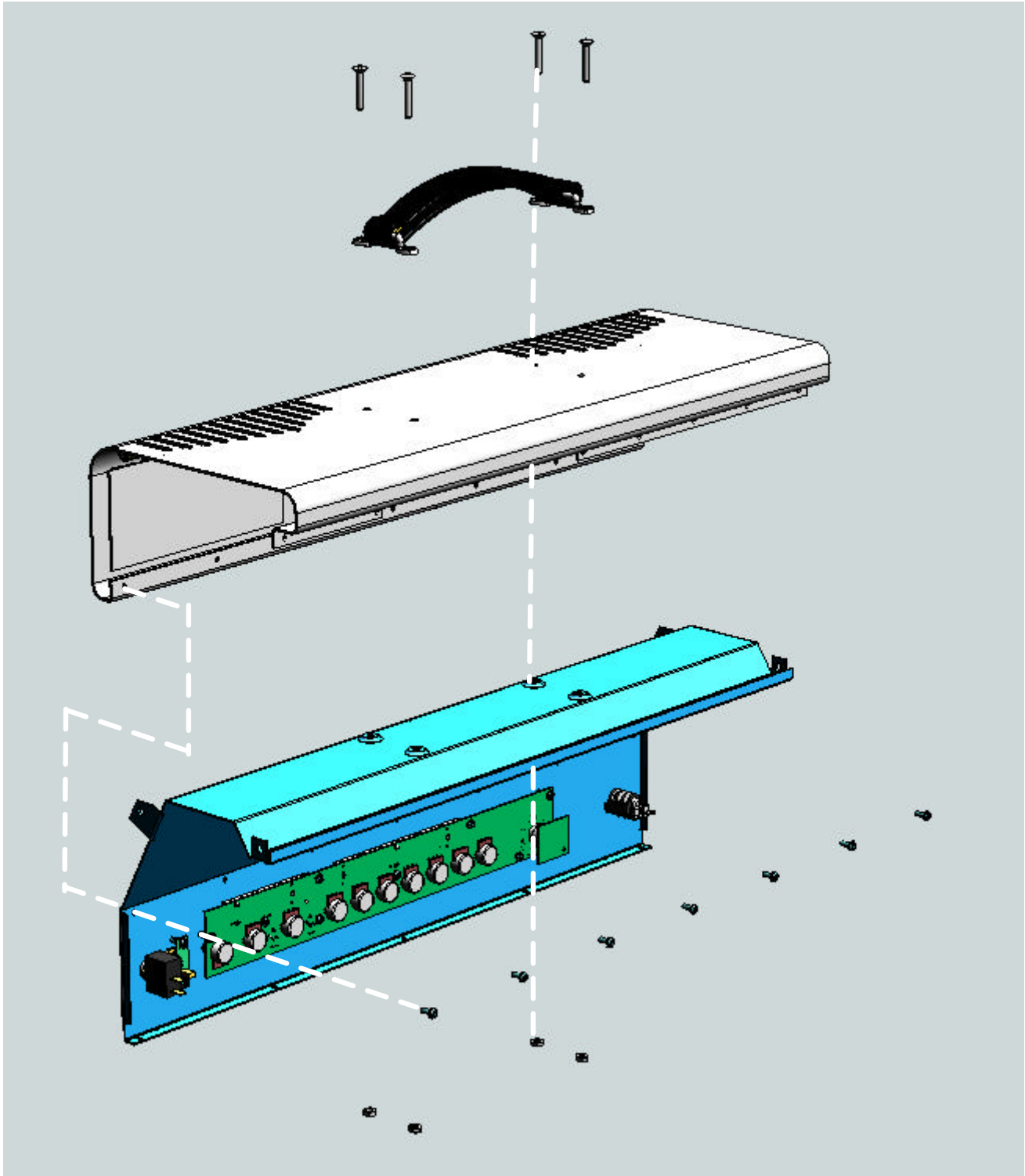

TOP CHASSIS / SHIELD SUBASSEMBLY – exploded view

Installation of SHIELD assembly into TOP CHASSIS.

g) Install GROMMIT #30-75-9600, and feed (#21-36-0265) cable (1 per) through SHIELD wall.

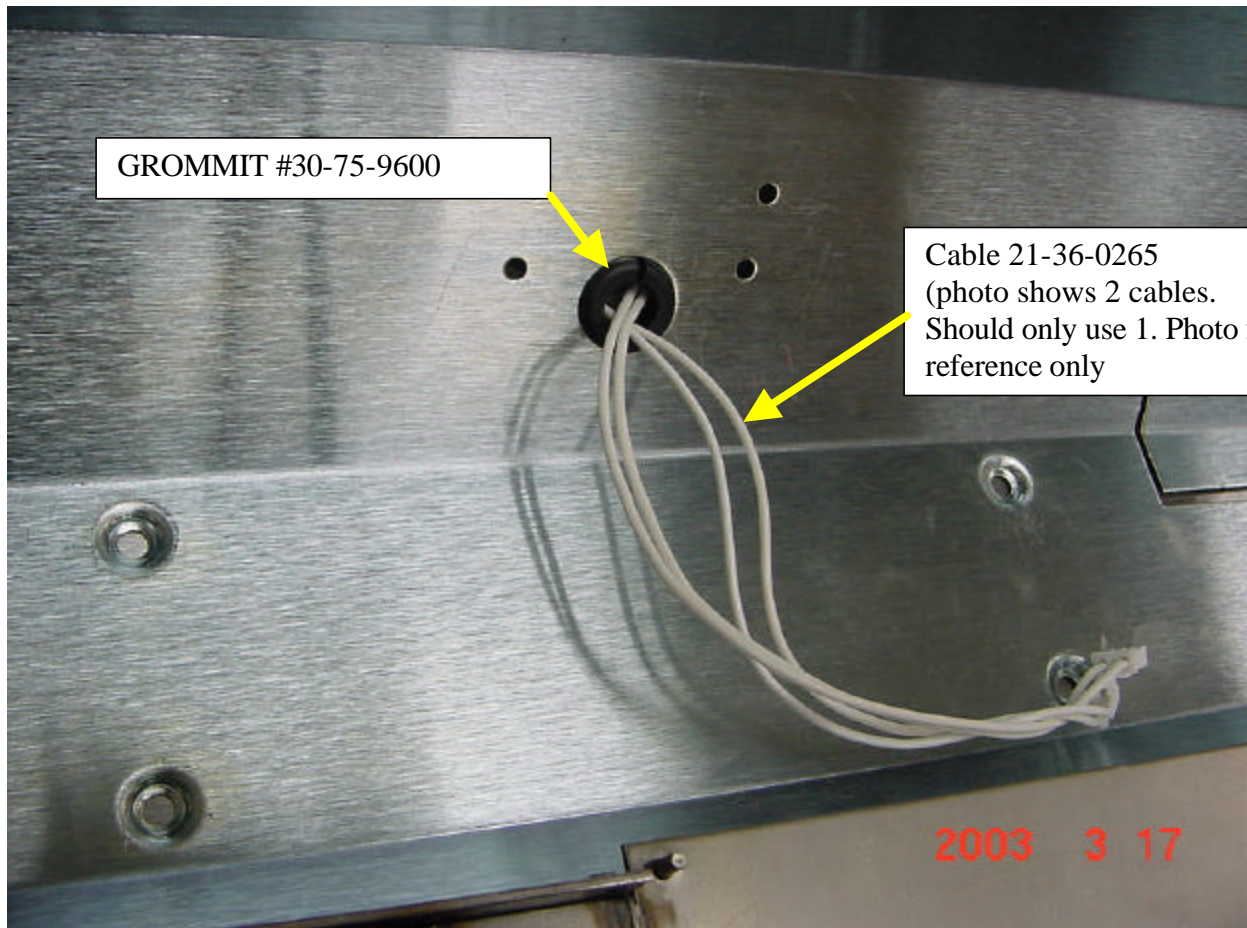

LINE 6

Engineering

g) Rotate SHIELD subassembly into TOP CHASSIS as shown.

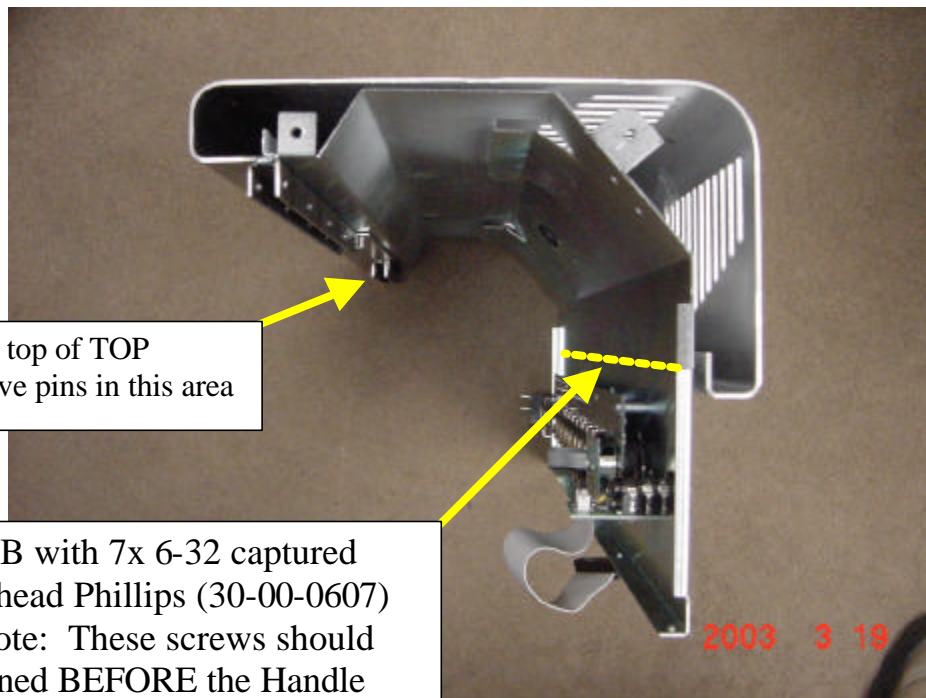
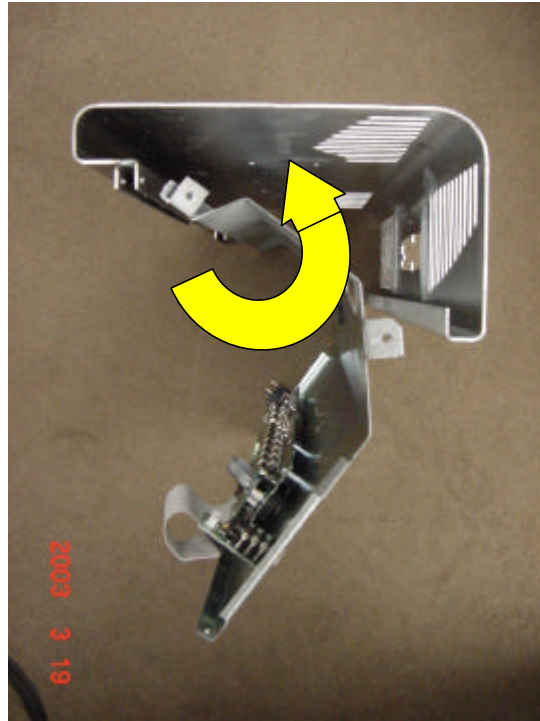

Shield rests on top of TOP CHASSIS above pins in this area

Secure the PCB with 7x 6-32 captured lock-star pan head Phillips (30-00-0607) along here. Note: These screws should be fully tightened BEFORE the Handle screws.

LINE 6

Engineering

g) Install HANDLE screws (# 30-00-0041), through HANDLE (30-57-0001), TOP CHASSIS and SHIELD walls and use 10-32 lock nuts (# 30-06-0024) to secure handle. Torque 12 in/lbs.

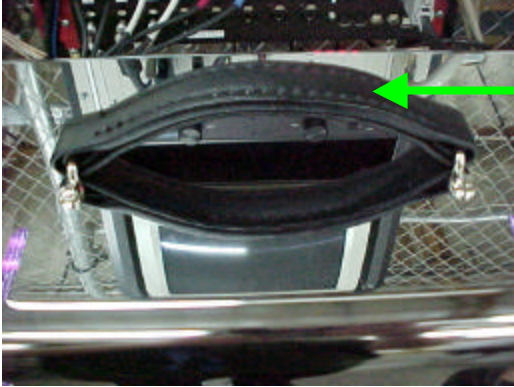

Pre-form the HANDLE (#30-57-0001), into a smooth radius curve as shown. DO NOT BEND AT THE CENTER POINT.

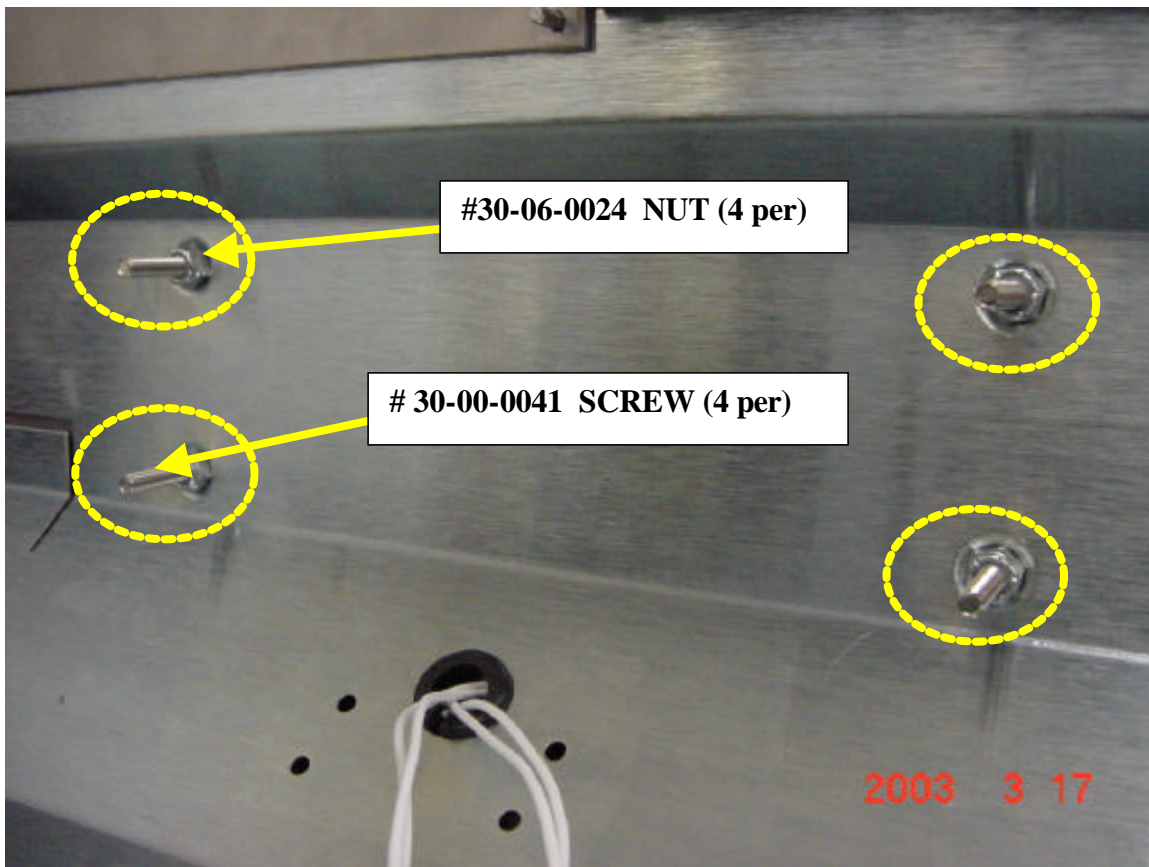

LINE 6

Engineering

g) Attach MAIN PCBA ribbon cable (# 21-34-9034-1) to USER INTERFACE PCBA.
Attach GUITAR INPUT cable to MAIN PCBA (#21-34-0015).

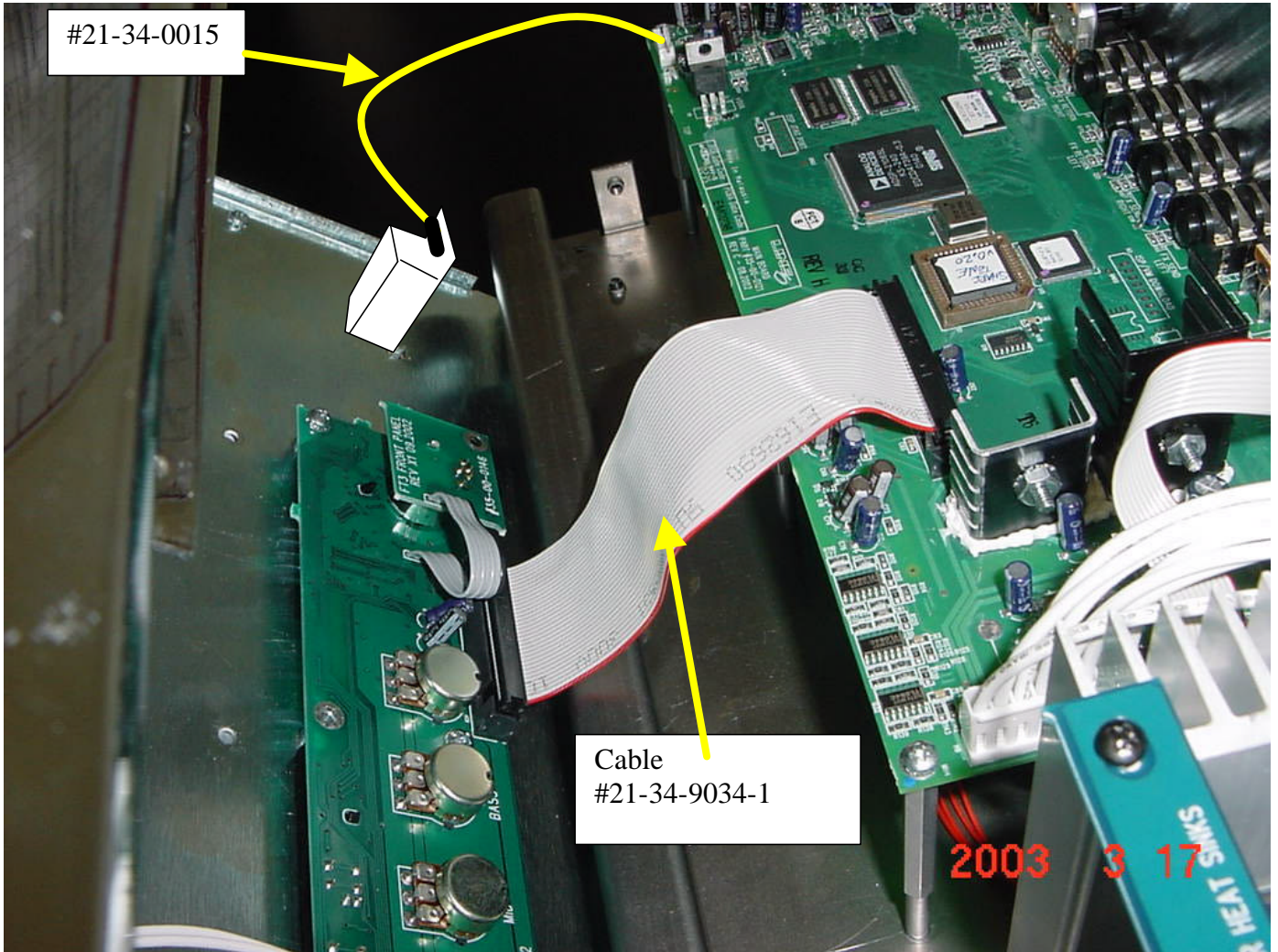

LINE 6

Engineering

g) Attach #21-36-0265 cable to POWER SUPPLY header (J1) as shown.

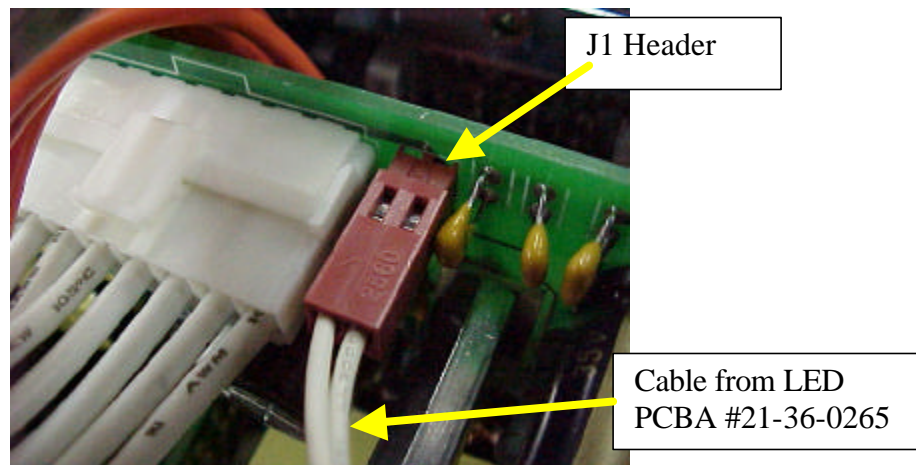
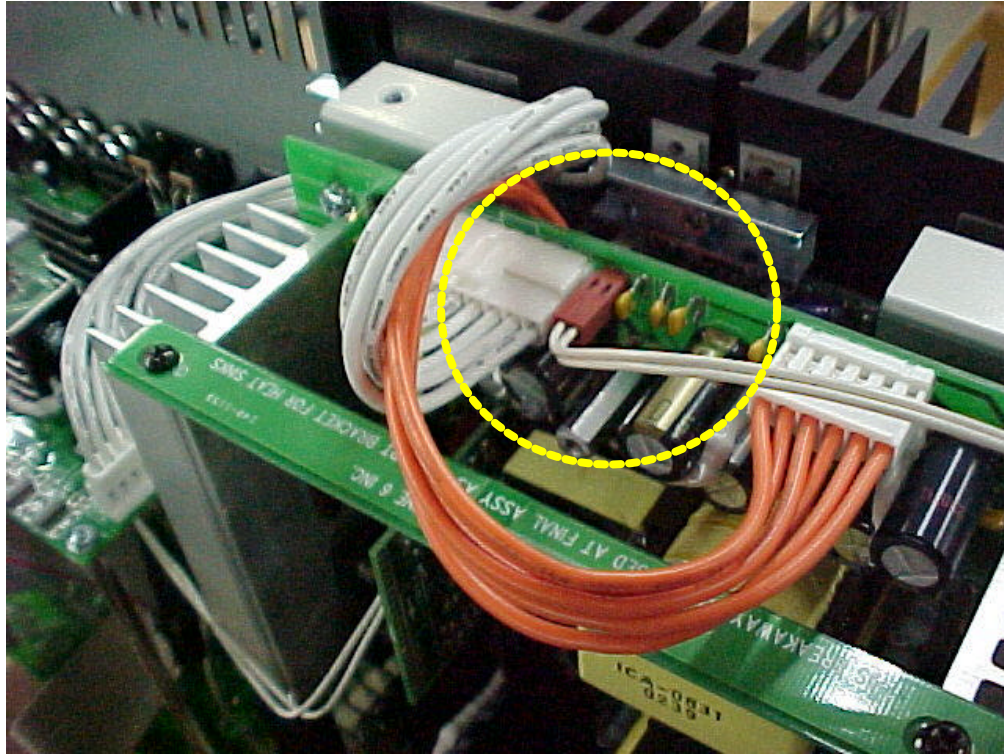

LINE 6
Engineering

g) Insert the two TOP CHASSIS Pins into the mounting channels in the POWER AMP HEATSINK.

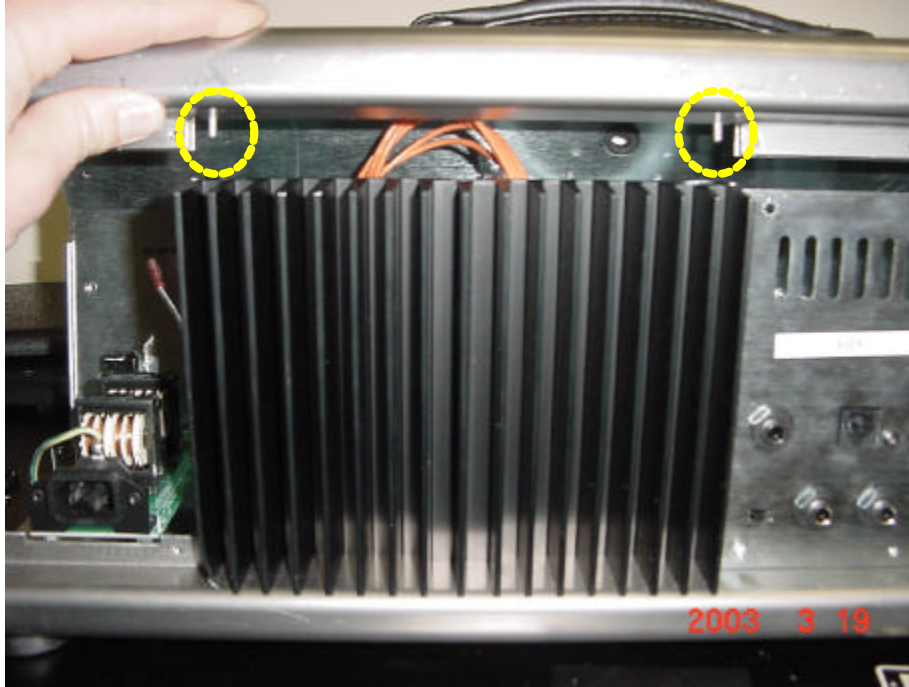

Rear View – POWER AMP heatsink & TOP CHASSIS pins

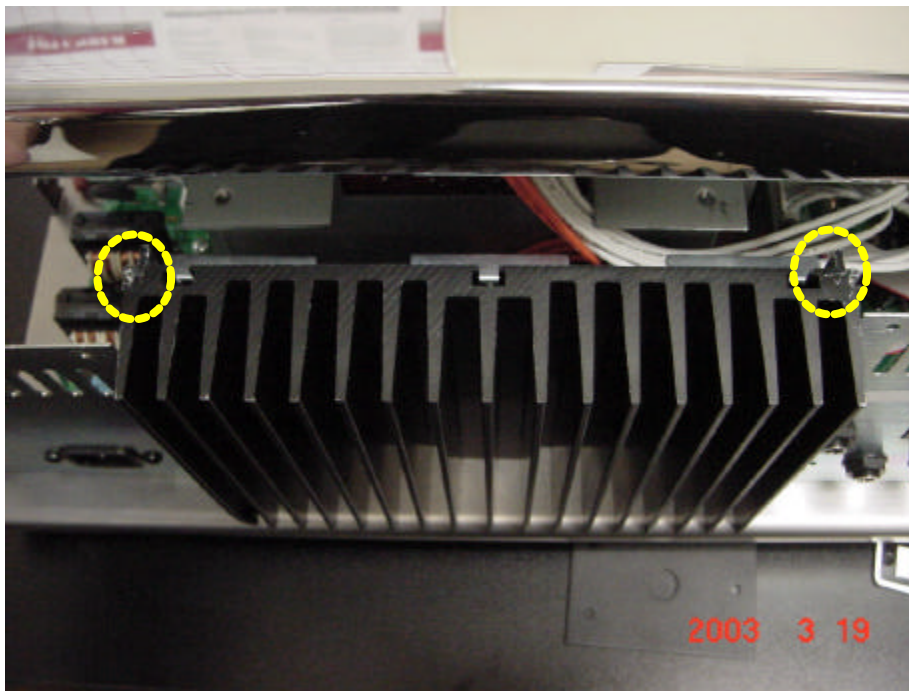

Top View – POWER AMP heatsink mounting channel locations

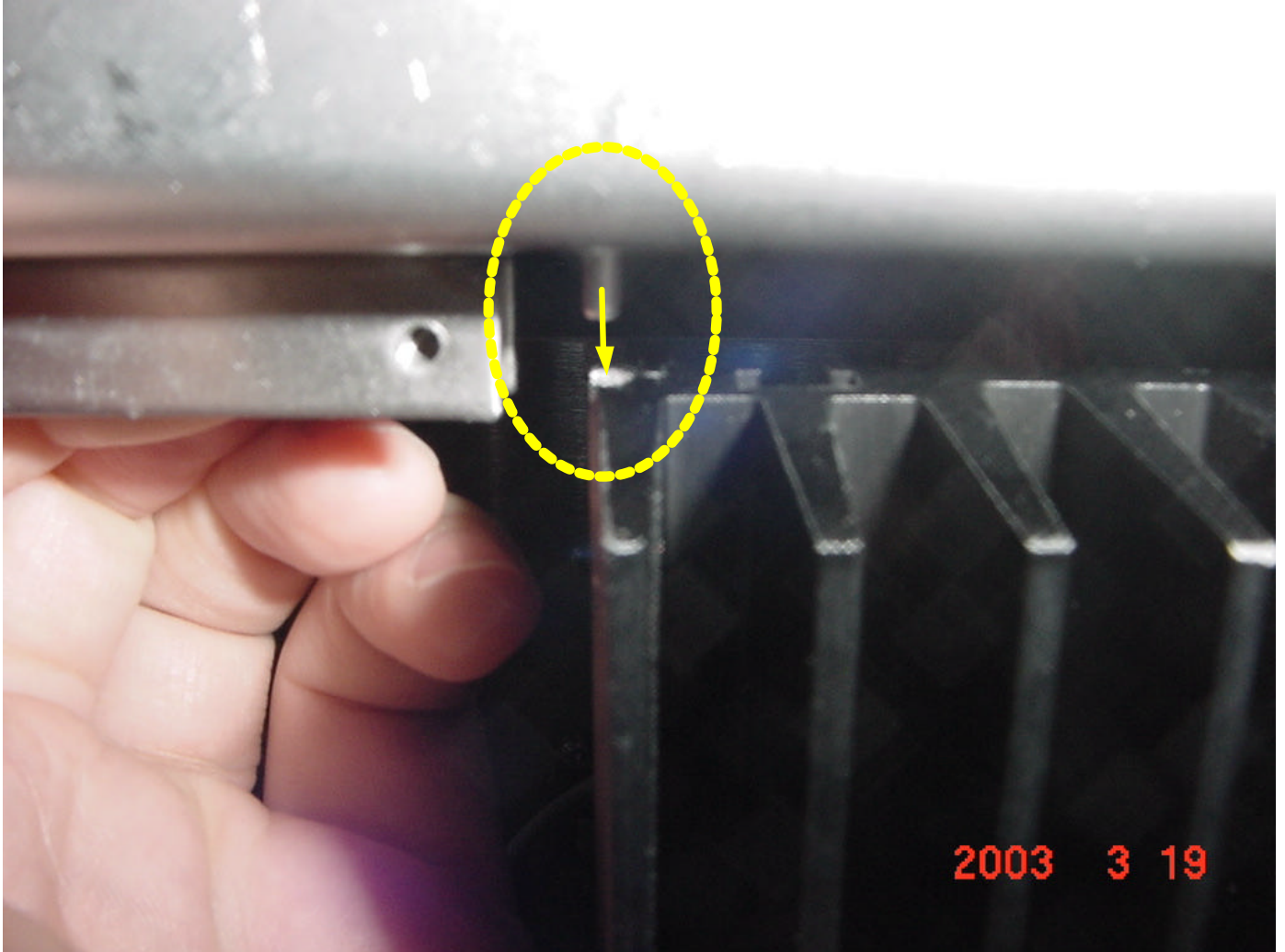

TOP CHASSIS pin detail - Left Side

LINE 6
Engineering

h) Install the AC PANEL onto the CHASSIS assembly as shown. 4 screws #30-00-0375. Torque 10-12 in/lbs. AC jack screws (2 per -# 30-00-8375) 4-5 in/lbs.

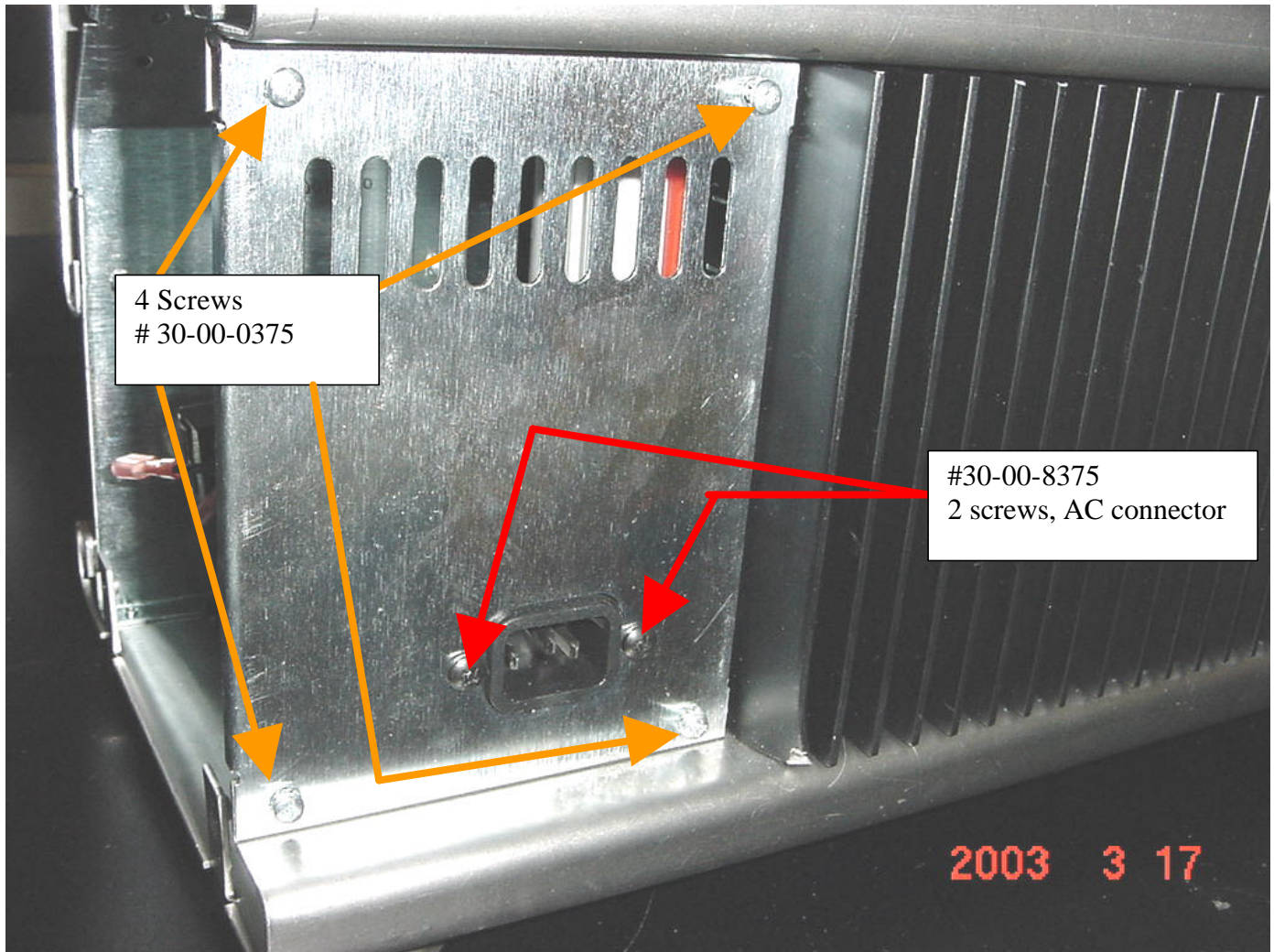

LINE 6
Engineering

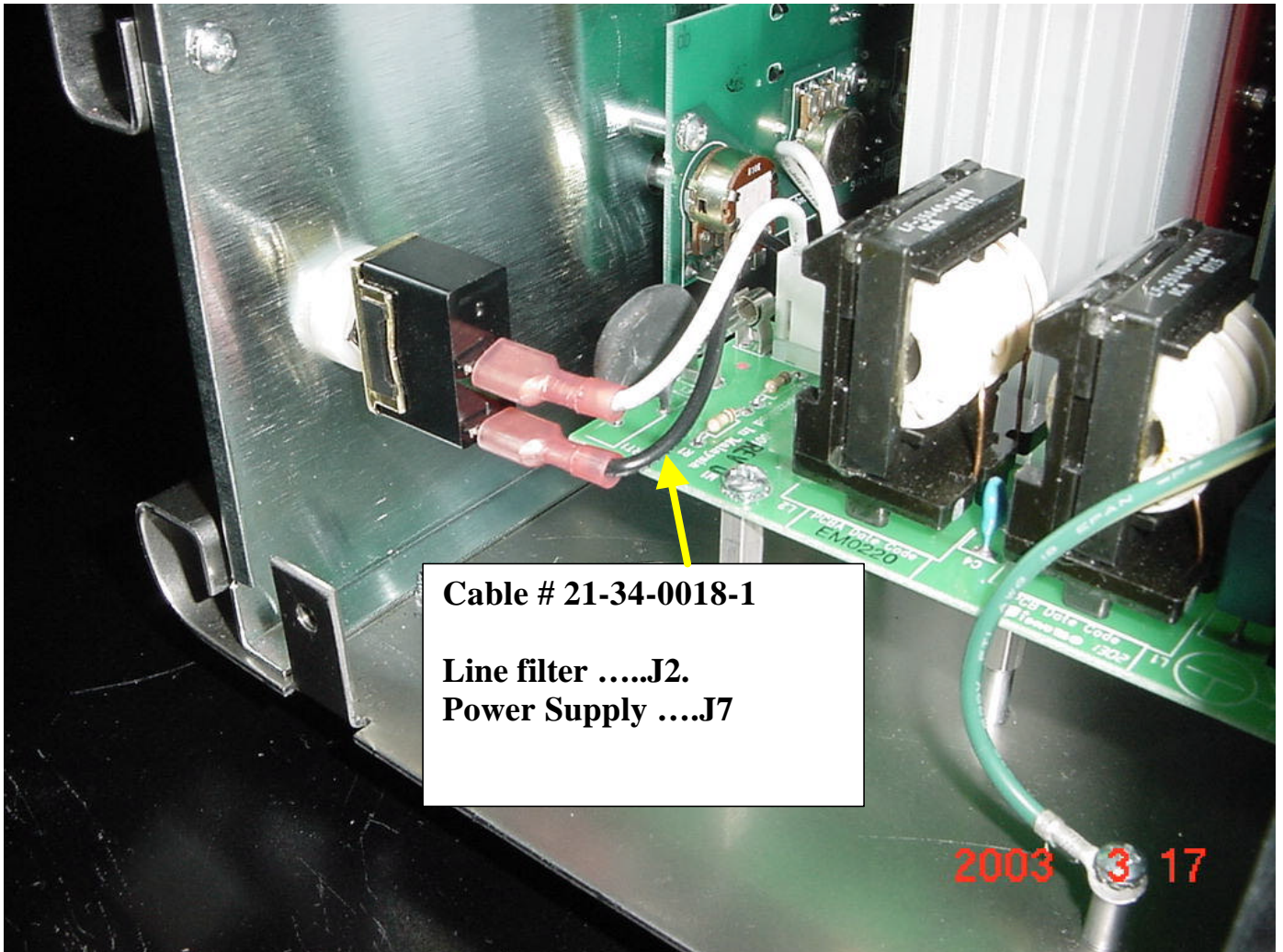

Install cable (# 21-34-0018-1) to the Power switch, Line filter PCBA, and Power supply PCBA, as shown.
Note: White cable to top connector of Switch.

LINE 6

Engineering

i) Attach SHIELD to BASE CHASSIS. Torque screws to 10-12 in-lbs.

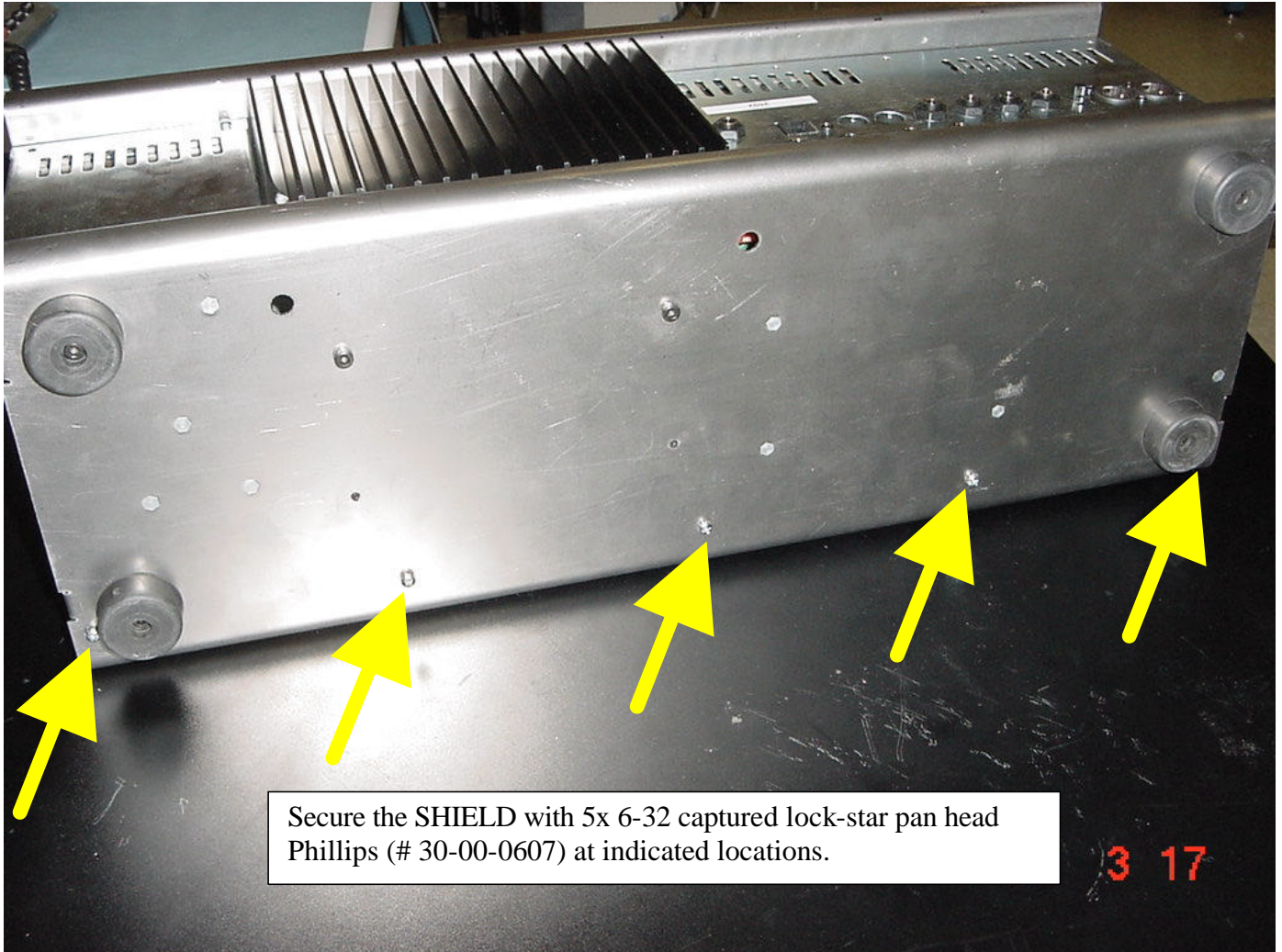

Secure the SHIELD with 5x 6-32 captured lock-star pan head Phillips (# 30-00-0607) at indicated locations.

3 17

LINE 6

Engineering

j) Install two nickel plated PLUGS (# 30-10-0001) into the BASE CHASSIS Power Amp heatsink screw access hole locations as shown.

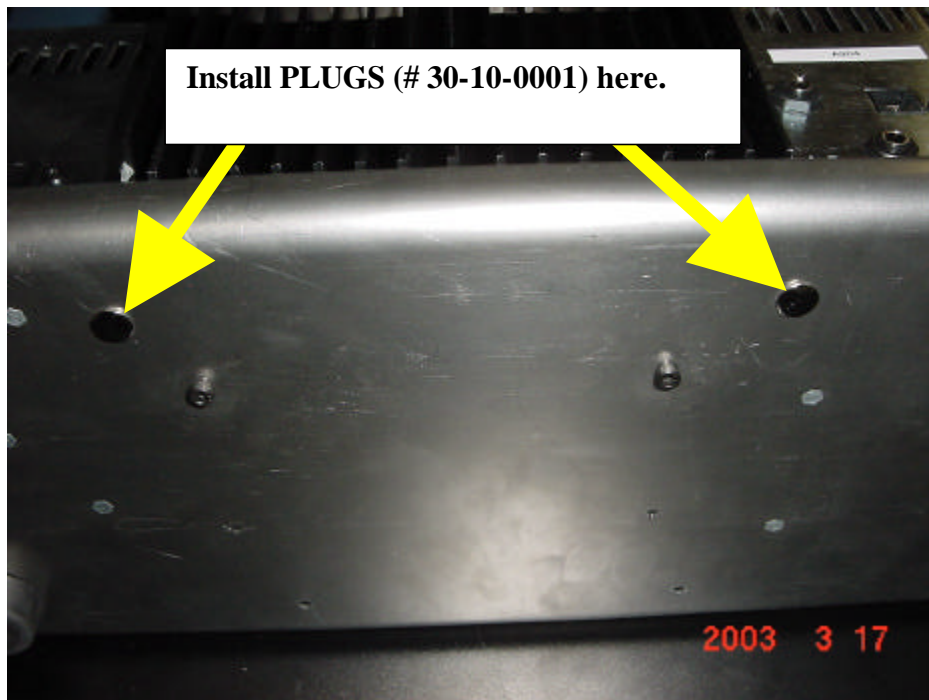
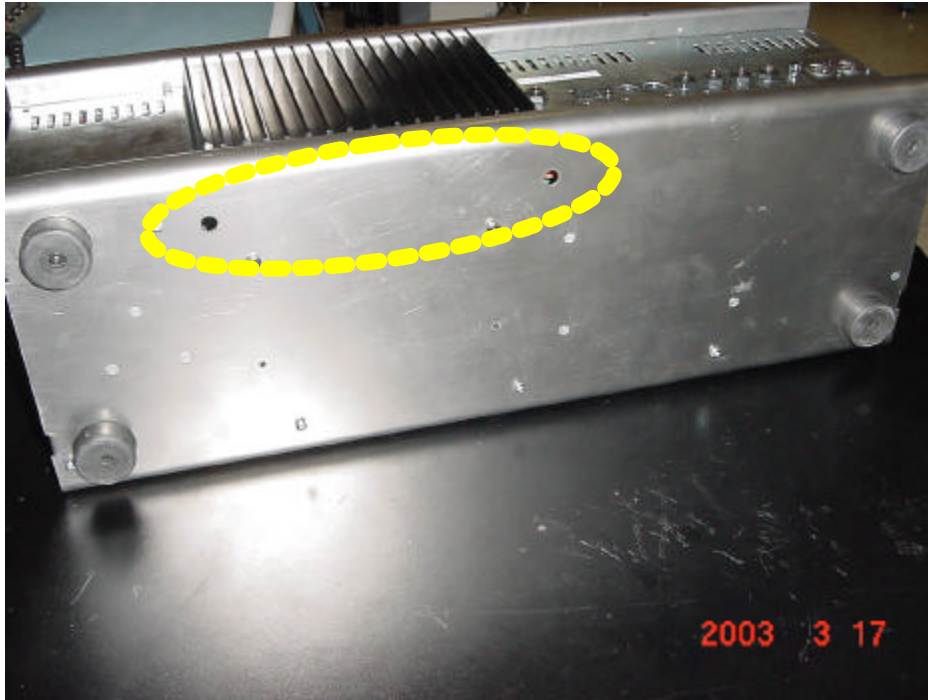

LINE 6
Engineering

k) Install two nickel plated PLUGS (30-10-0001) by firmly pressing the parts into the holes as shown.



LINE 6
Engineering

1) Install LOGO (#30-60-0005) onto TOP CHASSIS, using two 3-48 black flat head screws (# 30-00-0040). Torque to 5-6 in/lbs.

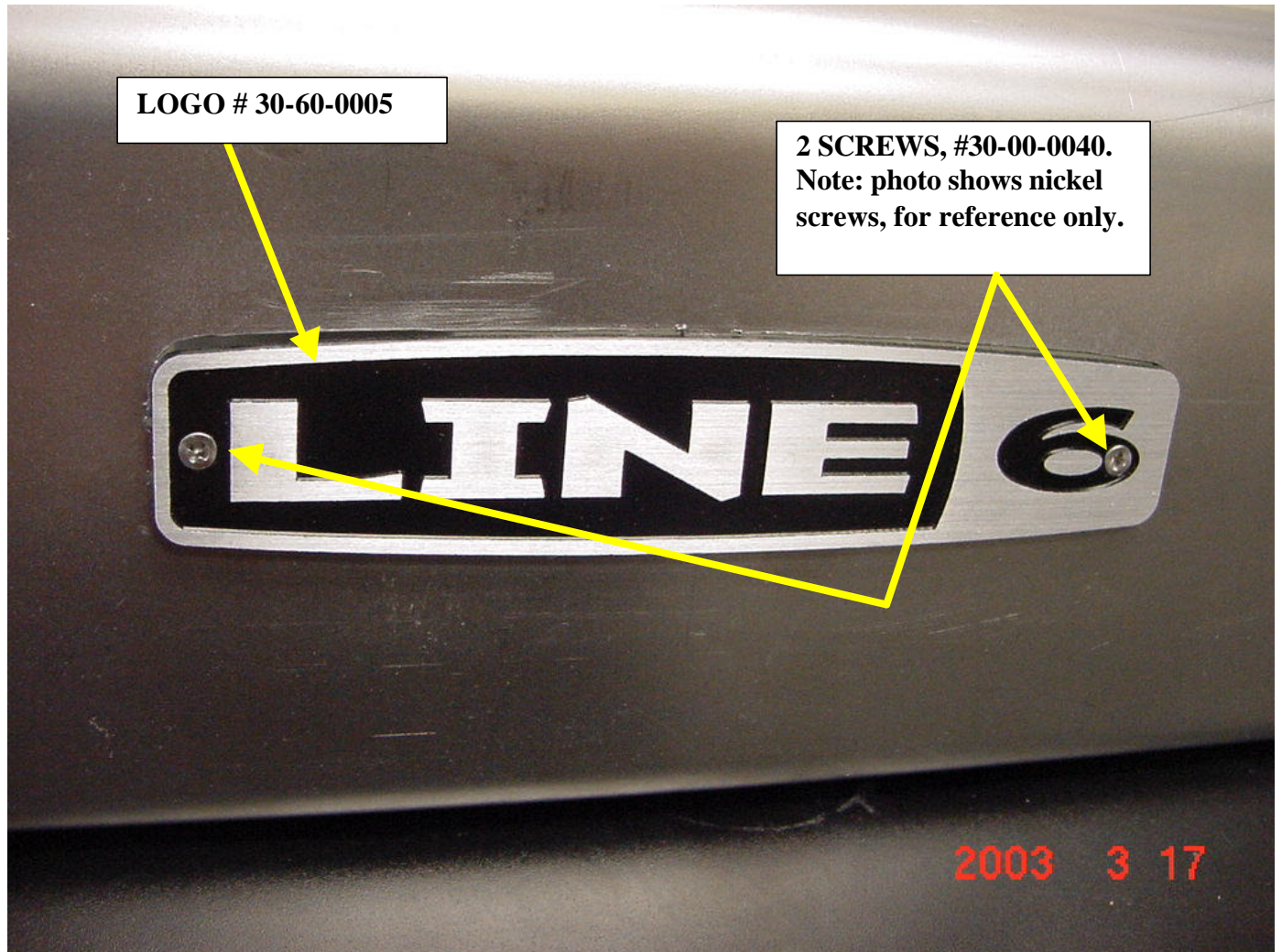

LINE 6 Engineering

m) Install End Caps.

Install end caps #30-33-0039-1 (right hand side) & #30-33-0039-2 (left hand side, using screws #30-00-0039 4 per side. Torque to 10 in/lbs.

Screws #30-00-0039
4 per side .

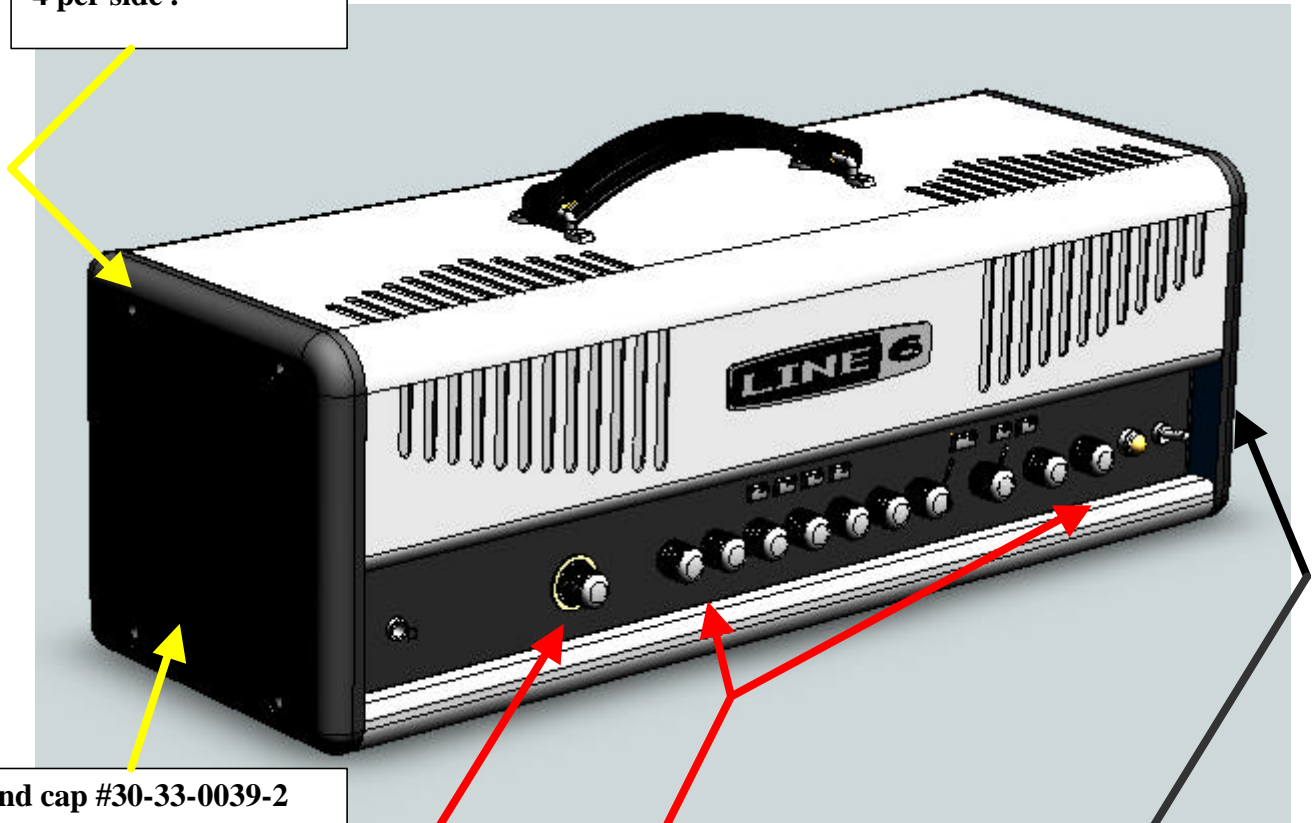

Left End cap #30-33-0039-2

Knob
#30-45-0008 (1 per)

Knobs w/indicator
#30-45-0007 (10 per)

Right End cap #30-33-0039-1

n) Install Knobs.

Install “Model” Knob 30-45-0008 (1 per), and Knobs w/indicator 30-45-0007 (10 per) as shown above. Make sure that they are fully seated.



Test & Inspect completed unit.

To help ensure maximum quality of all products, it is the responsibility of the assembler to complete a post assembly inspection prior to sending the unit on to electrical testing and final inspection. This should help achieve one goal: no unit shall ever be returned from test and inspection for rework because of a mechanical defect that could have been corrected at the assembly stage. Remember that things that have already been inspected during assembly may have been inadvertently damaged during the assembly process. With this in mind, fully inspect the unit for mechanical defects. Things to look for include:

- Cosmetic damage to any visible surface of the unit. This includes but is not limited to: defects to the silk-screening – both front and back panel, dents, dings or scratches in all outer surfaces, smooth even surface color of the front panel, even Chrome finish, scratches or fingerprints on buttons, damage to button text or keycaps, and/or visible process marks on knobs and other plastic parts.
- **Unit must be free of all fingerprints.**
- Proper complete assembly of all parts. This includes but is not limited to: Presence of all parts, flush full insertion of all screws. Even consistent spacing of knobs, proper centering of lenses in cutouts, etc.
- Proper mechanical function of all components. This includes re-testing all knobs for smooth consistent feel, testing all buttons for proper feel.
- Add serial number label (40-25-0101) to rear of unit (space is specified on the silkscreen), and make sure that the unit is marked to reflect the correct AC voltage- Cover up LABELS #40-30-0020 used for 220/240v units, and #40-30-0017 used for 100v models.

If there is any question about the quality of a unit, consult a supervisor for guidance. If the unit passes assembly inspection, the unit is complete and ready to proceed to electrical testing, final inspection, pack and ship.

Unit Final configuration:

Front panel:

- ❑ POWER SWITCH: Off
- ❑ DRIVE, BASS, MID, TREBLE, PRESENCE, CHANNEL VOL to 12:00 O'Clock.
- ❑ REVERB, MOD, DELAY, MASTER to 7:00 O'Clock (fully counter clockwise)

Rear Panel:

- ❑ LEVEL TRIM: 12:00 O'Clock
- ❑ GROUND LIFT: Ground



PACK OUT LIST.

1. #40-25-0100 LABEL BARCODE SERIAL NUMBER 4 PANEL.....(1 PER)
2. POWER CORDS (1 per -depends on voltage configuration):
 - i) #21-37-1160 CABLE POWER US/JA.....(1 PER)
 - ii) #21-37-1163 CABLE POWER AU(1 PER)
 - iii) #21-37-1167 CABLE POWER EU(1 PER)
 - iv) #21-37-1168 CABLE POWER UK(1 PER)
3. #40-00-0021 MANUAL, USER(1 PER)
4. #40-00-0024 PRESET CHART, HD147(1 PER)
- 5.#40 -20-0010 BAG PLASTIC 43"x 38" x .004" CLEAR....(1 PER)
6. #40-20-0011 BAG PLASTIC 10"x 16" 2MIL CLEAR.....(1 PER)
7. #40-10-0059 FOAM CORNERS.....(8 PER)
8. #40-10-0057 CARTON GIFT HD147(1 PER)
9. #55-00-0001 COVER HD147 HEAD(1 PER)



HD147
Pilot Handbook

The serial number can be found on the back panel of your HD 147. It's the number that begins with "(21)". Please note it here for future reference:

SERIAL NO: _____

WARNING: To reduce the risk of fire or electric shock, do not expose this appliance to rain or moisture.

CAUTION: To reduce the risk of fire or electric shock, do not remove screws. No user-serviceable parts inside. Refer servicing to qualified service personnel.

CAUTION: This equipment has been tested and found to comply with the limits for a Class B digital device pursuant to Part 15 of FCC Rules. Operation is subject to the following two conditions: (1) This device may not cause harmful interference, and (2) this device must accept any interference received, including interference that may cause undesired operation.



The lightning symbol within a triangle means "electrical caution!" It indicates the presence of information about operating voltage and potential risks of electrical shock.



The exclamation point within a triangle means "caution!" Please read the information next to all caution signs.

YOU SHOULD READ THESE IMPORTANT SAFETY INSTRUCTIONS KEEP THESE INSTRUCTIONS IN A SAFE PLACE

Before using your HD 147, carefully read the applicable items of these operating instructions and safety suggestions:

1. Obey all warnings on the HD 147 and in this Pilot's Handbook.
2. Do not place near heat sources, such as radiators, heat registers, or appliances which produce heat.
3. Guard against objects or liquids entering the enclosure.
4. Connect only to AC power outlets rated 100-120V or 230V 47-63Hz (depending on the voltage range of the unit; refer to the back panel). Current ratings should be 4A for the 120V range and 2 A for the 230V range.
5. Do not step on power cords. Do not place items on top of power cords so that they are pinched or leaned on. Pay particular attention to the cord at the plug end and the point where it connects to the amp.
6. Unplug your HD 147 when not in use for extended periods of time.
7. Do not perform service operations beyond those described in the HD 147 Pilot's Handbook. In the following circumstances, repairs should be performed only by qualified service personnel:
 - liquid is spilled into the unit
 - an object falls into the unit
 - the unit does not operate normally or changes in performance in a significant way
 - the unit is dropped or the enclosure is damaged
8. Prolonged listening at high volume levels may cause irreparable hearing loss and/or damage. Always be sure to practice "safe listening."



Please Note:

Line 6, HD 147, Flextone, Vetta, POD, Duoverb and FBV are trademarks of Line 6, Inc. All other product names, trademarks, and artists' names are the property of their respective owners, which are in no way associated or affiliated with Line 6. Product names, images, and artists' names are used solely to identify the products whose tones and sounds were studied during Line 6's sound model development for this product. The use of these products, trademarks, images, and artists' names does not imply any cooperation or endorsement.

Welcome to HD 147	1 • 1
Register	1 • 1
Connect at www.line6.com	1 • 1
Line 6 and HD 147.....	1 • 1

Working It

Quick Start Guide	2 • 1
Front Panel Features	2 • 2
Manual Mode: What You See Is What You Get.....	2 • 6
Using The Channel Memories.....	2 • 6
Creating Amp Defaults.....	2 • 7
Rear Panel Features.....	2 • 8
Speaker Cabinet Basics.....	2 • 10
Using Your Direct XLR Outputs.....	2 • 15

The Amps & Cabs

What's In There.....	3 • 1
The Cabinets	3 • 23

The Effects

About the Delay and Modulation Effects	4 • 1
Delays.....	4 • 2
Modulations.....	4 • 4

Using Your Feet

FBV Class Foot Controllers.....	5 • 1
Connecting an FBV	5 • 1
So What Do All These Buttons and Pedals Do?	5 • 2
Saving and Naming with an FBV	5 • 4

Appendices

Amp Models	A
Cabinet Models.....	B
MIDI Channel, Program Change & Sysex.....	C
MIDI Continuous Controllers.....	D
Customer Service	E
Warranty Information	F

WELCOME TO HD 147

Register

Thanks for buying a HD 147! Please send in that included registration card or click on over to www.line6.com to get registered. We'll wait right here...

Line 6 and HD 147

You probably know Line 6 as a technological innovator in the guitar world—first to put digital software modeling technology to work in guitar combo amps, pioneering direct recording technology in POD and other products, and capturing the soul of classic pedals in modern stomp boxes. We make gear that's packed with features and hi-tech breakthroughs, and bring new value and capabilities to guitarists.

Like all Line 6 products, the HD 147 is packed with tone—full of refined models of premier guitar amps and effects from the past five decades.

What sets the HD 147 apart from other amplifiers of its stature are the 14 custom Line 6 custom amp models that put you on the forefront of a new wave of Line 6 innovation. You see, after carefully modeling a plethora of coveted vintage and modern amps, our tone craftsmen have picked up a thing or two about what makes great amps magical. Armed with this knowledge, our hardy band of adventurers has tunneled deep into the “Middle Earth” of guitar tone on a tireless quest to bring you awesome new gems of sonic power.

By bringing you these unique tonal treasures along side a bevy of premier amp models ranging from punishing high gain tone to crystal clear cleans, HD 147 gives you a trove of tonal riches you can't get from anywhere but Line 6.

HD 147 also includes Line 6's signature A.I.R. II direct outs, so you of course get your tone to its destination without compromise or complication in every situation. And, of course, it's all ready to dazzle your audience with its other worldly chromed chassis and glowing black lights.

So flip the page, you lucky devil. And let's take your hot new tone buggy for a spin!

Connect at www.line6.com

Join the thriving community at www.line6.com. The discussion boards are humming with Line 6ers sharing insights to get the most from their gear and the great adventure of making music. Learn what's new from the artists that rely on Line 6, be the first to hear about new products, and tap into Customer Support via the powerful FAQTRAQ system.

WORKING IT

In a rush? Well, then, just read this page and come back for the rest later:

Quick Start Guide

POWER: Connect the power cord from HD 147's rear panel to your power outlet. *But don't turn the power on yet.*

PLUG IN: Connect your speaker cabinet and set the impedance switch on the back of the amp to match the impedance of your cab. Jack your guitar into HD 147's **Input**. Turn HD 147's **Master** knob (on the far right) all the way down, and kick the **Power** switch to fire that bad boy up. Spin **Master** up to 9 o'clock or so. Rock on!

MODELS KNOB: Spin this to select from the 16 amp flavors, each with two variations, for 32 Amp Models total.

DRIVE, BASS, MID, TREBLE, PRESENCE, VOLUME KNOBS: What you see is what you get here—turn knobs 'til things sound good!

DELAY: Press the button to the left of the **Delay** knob to pick one of the Delay effects. Tap in a tempo for the delay, and turn the **Delay Tweak** knob to get more or less of the effect.

MOD: Press the button to the left of the **Mod** knob to pick one of the Mod effects. Turn the **Mod Tweak** knob to adjust the amount of the selected effect.

COMP/GATE: Press **Comp** and/or **Gate** to engage each effect. The Compressor will smooth out your dynamics and add sustain. The Gate will mute the inherent noise common to high gain amp tones when you're not playing.

CHANNEL MEMORIES: These are like the buttons on a car radio that remember your favorite stations. Press A, B, C or D to recall one of the 4 Channel Memories. Press that button again to get back to "manual mode." You're in manual mode if none of the A, B, C, or D buttons are lit. And just like a car radio, hold any of the buttons for 3 seconds to save your current settings to that memory for later recall.

Front Panel Features

2 • 2

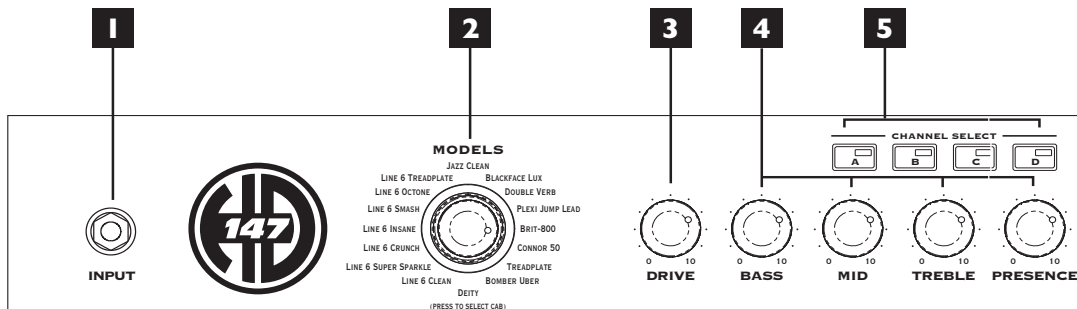

- 1. Guitar Input:** Plug your guitar in here.
- 2. Models - Amps:** As you turn this knob, one of the lights surrounding it will light. An AMBER (yellow) light next to one of the Model names tells you that you've selected that Amp Model. Turn the knob one more click to get a RED light, and you've got a whole new amp model within a similar genre. **Chapter 3** describes all 32 Amp Models.

Models - Cabs: When you select an Amp Model, your HD 147 is selecting an appropriate Cab Model to go with it behind the scenes. Many of the amp models on the HD 147 use the “No Cab” cabinet model. “No Cab” bypasses the additional cabinet coloration to allow the natural character of your speaker cabinet to come through. To choose a different cabinet from the 16 available models, press and hold the Model knob while turning it; you'll see GREEN lights. The cabs run from smallest to largest, so selecting green lights from “Line 6 Super Sparkle” through “Deity Lead” takes you all the way from petite combo amp cabinets to ferocious 4x12s. Turn to “Line 6 Clean” to bypass the cab modeling.

- 3. Drive:** Turn this knob to set how hard you're driving the chosen Amp Model. Similar to the input volume control on a non-master volume amp, the higher the setting, the more “dirt.”
- 4. Tone Controls – Bass, Mid, Treble and Presence:** These controls are made to behave like the controls of the amps that were modeled for HD 147. Twist them round until things sound just the way you like. See **Chapter 3** for details.

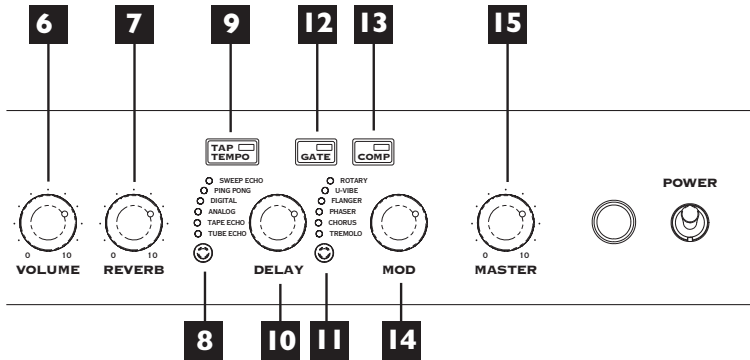

- 5. Channel Select Buttons – A, B, C, D:** HD 147 uses these buttons to remember your favorite settings—no more need to mark up the front of your amp with grease pencil to note your favorite settings! Each memory is pre-set with delicious tone when an HD 147 leaves the factory—press a button to hear the saved setting. As you do, notice that HD 147’s lights indicate which Amp Model is used in the Channel Memory, which effects are on, etc. To get back to the “manual mode,” just press the lit button again to turn it off. Plus...

As you come across your own favorite settings that you’d like to keep, you can save them to the A, B, C and D buttons to replace the factory presets. Just hold down any of A, B, C or D buttons for about 3 seconds until it flashes and presto—HD 147 has now memorized your custom tone for easy recall! See **Using The Channel Memories** on page 2•6 for more detail. The Line 6 FBV class foot controllers let you select these Channel Memories with your feet—and expand the number of memories recallable to a total of 36. **Chapter 5** has got the details.

- 6. Volume:** This knob controls the relative volume level of the “channel” you are playing through — thus, Channel Volume. Use this to balance levels between the sounds you store in two different HD 147 Channel Memories (say between your rhythm and lead tones).

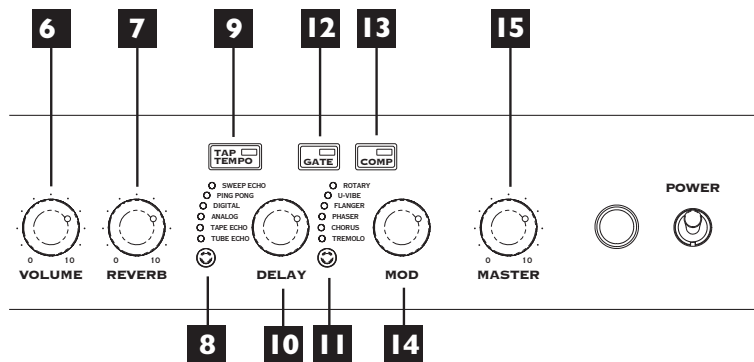

- 7. Reverb:** Just turn the knob to get the amount of reverb you'd like. Turn the knob fully counter-clockwise for no reverb.

Bonus Feature: Reverb Tweak- To adjust the type and decay of the Reverb, press and hold the Tap Tempo button and turn the **Reverb** knob. There are three different Reverb types accessible throughout the range of the knob. The first third of the knob is a spring, the second third a Room, and the final third a Plate, each with a range of decays, from short to long.

- 8. Delay Select:** Press this to step through the Delay effects listed to the left of the Delay knob, or to turn off the Delay (all lights off). Press and hold the **Delay Select** button to bypass the current model without losing your place in the effects list. The next press of the **Delay Select** button restores the model you had previously selected. (The bypass feature works with the **Mod Select** button too!)
- 9. Tap Tempo:** Tap the button at the tempo you'd like—the delay time switches to match that tempo.
- 10. Delay (Tweak):** Dynamically adjusts multiple delay parameters, including mix, feedback and tone. Spin it to get more or less delay.

Delay Time - To set the delay time without having to deal with tapping, press and hold the **Tap Tempo** button while turning the **Delay** knob. For shorter delays, dial counter-clockwise. Longer delays, clockwise.

Bonus Features: Delay Feedback - To adjust only the Delay Feedback, press and hold the **Delay Select** button and turn the **Delay** knob. *Note: Turning the Delay knob after tweaking the feedback will override your feedback setting. So it's best to first get the general Delay set with the Delay knob, and then fine-tune the feedback if necessary.*

11. **Mod:** Press this to step through the Mod effects listed to the left of the Mod knob, or to turn off the Mod (all lights off).
12. **Gate:** Engages the on-board gate. The gate kicks in when your guitar signal drops below a certain “threshold,” and is intended to mute the noise that you might otherwise hear at that time. To adjust the Gate threshold, press and hold the **Gate** button while turning either the **Delay** or **Mod** knob. The lower the threshold (clockwise), the more the sustain of your notes will tend to get chopped off.
13. **Comp:** Engages the on-board Compressor. The compressor will add sustain to your guitar sound, and smooth out your dynamics. To set the amount of compression, press and hold the **Comp** button while turning either the **Delay** or **Mod** knob. The higher the setting, (clockwise) the more your notes will sustain.
14. **Mod (Tweak):** Dynamically adjusts multiple modulation parameters, including rate and depth.

Bonus Feature: Modulation 2nd Function - Each modulation model can be fine-tuned by pressing and holding the Mod Button while turning the **Mod** Knob. The list below shows which fine-tuning is available for each effect.

MOD Effect	Fine-Tune
Rotary	Tone
U-Vibe	Depth
Phaser	Feedback
Flanger	Rate
Chorus	Rate
Tremolo	Waveform (sine – square)

15. **Master:** Sets the overall volume of your HD 147. Adjust this to set your basic loudness, then use the **Volume** knob to balance the relative volume of the sounds you store with the A, B, C, D buttons.

Manual Mode: What You See Is What You Get

When *none* of the **A, B, C, D Buttons** are lit, HD 147 is operating in **Manual Mode**, meaning that all of the controls are active and the sound of the amp is determined by the current knob settings. Just like a regular amplifier, right?

If you are not in **Manual Mode** and would like to be, simply give the lit **A, B, C,** or **D Button** a quick press.

Using The Channel Memories

HD 147 can store and recall your favorite settings using the **A, B, C, D Buttons**.

Save: Any time you've dialed up a sound that you'd like to save for later recall, all you have to do is hold down button **A, B, C** or **D** for 3 seconds. At the end of that 3 seconds, the button you held will flash to let you know that you've successfully stored your present setting of all the controls to that button.

Recall: When you tap one of the **A, B, C, D Buttons** to light it up, HD 147 recalls the settings that were stored in that button's Channel Memory. This includes your choice of Amp and Cab **Models**, the **Drive, Bass, Mid, Treble, Presence, Reverb** and **Channel Volume** settings, plus your **Mod** and **Delay** settings. *Note: The Master Volume setting is not stored with each Channel. Instead, it acts as a global volume that controls the overall level of all channels.*

The various front panel lights will show the recalled settings, but the knobs will not. Turning any knob or operating any button will override the recalled setting for that control only. To override all the recalled settings and get the sound determined by the current setting of all the knobs, press the lit **A, B, C,** or **D Button**. You're now back in what-you-see-is-what-you-get **Manual Mode**.

See **Chapter 5** for details on how to store and recall a total of 36 HD 147 Channel Memories using your feet.

To reset all the Channel Memories (including all 36 available from an FBV and MIDI) to their factory state, hold the **A** and **D Buttons** while powering up your HD 147.

Creating Amp Defaults

Amp Defaults are simply snapshots of all the important Amp Model controls that are automatically recalled when you select a model via the **Model** knob. Every time you select a model, HD 147 loads the associated Amp Default to expedite your trip to tone nirvana.

You can edit any or all of the Amp Defaults, and pack your HD 147 with all the special amp-tweaking genius that only you possess. This brilliance will then be available instantly at the turn of the **MODEL** knob. For instance, when you turn the **MODEL** knob to load the Plexi-45 model, you'll get *your* personal Plexi-45, with all the controls set for your very own version! Here's how it works:

Choose an Amp Model, change the cab if you like, dial in the amp controls, etc. When you're happy with what you've got, press and hold the **MODEL** knob *being careful not to turn it*. After about 5 seconds, the light for the selected model will start to blink and you can let go. Your custom settings have been saved.

Using MIDI, you can customize a whole bunch of other controls and store them with the Amp Setup. Check out the MIDI Appendix for detail on the continuous controller messages that drive each of these parameters. After making tweaks via MIDI, you can save the result as the Amp Default.

Amp parameters accessible via MIDI include:

Drive	Compression Gain	Reverb Model
Bass	Compression Threshold	Reverb Decay
Mid	Comp Enable	Reverb Tone
Treble	Gate Threshold	A.I.R. II Model
Presence	Gate Decay Time	Cabinet Model
Channel Volume	Noise Gate Enable	Volume PRE/POST

Rear Panel Features

2 • 8

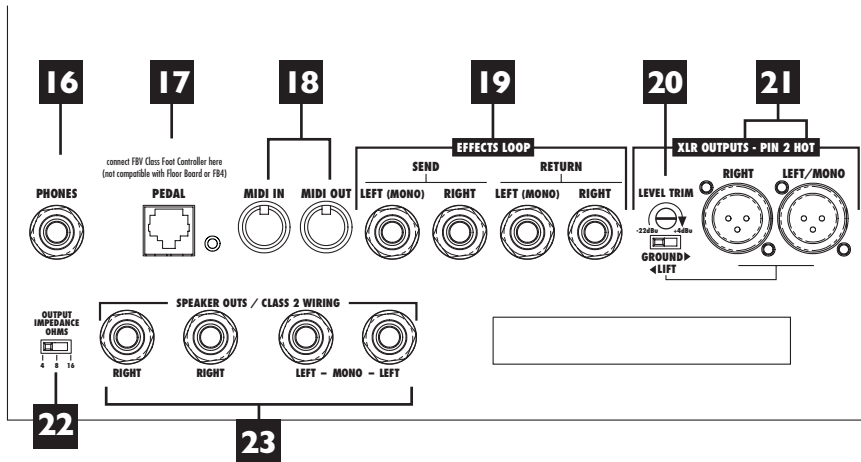

- 16. Phones:** Keep it quiet around the house by connecting headphones to the **Phones** jack—plugging in headphones disables your speaker outputs. The **Master** knob sets the output level while you’re using headphones—be sure you turn the knob down as you switch between headphones and the speakers to make sure you don’t unexpectedly blast yourself with volume.
- 17. Pedal:** Connect the RJ-45 cable supplied with your FBV or FBV Shortboard here. **Chapter 5** has the full details.
- 18. MIDI In & MIDI Out:** Connect standard MIDI cables here. HD 147 always sends and receives on MIDI Channel 1. See the MIDI appendix for more details.

19. **Effects Loop:** Use the Left(Mono) Send and Return for a mono rack effect. Connect stereo effects as shown. Generally, stomp boxes go before the amp, *not* in this loop.

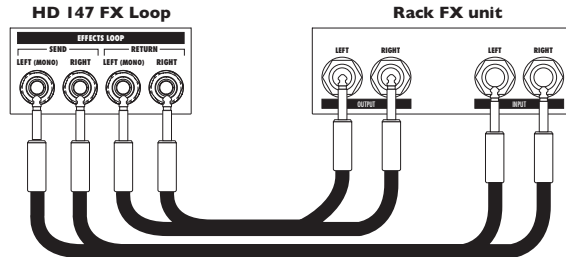

20. **Level Trim:** The level of the XLR Outputs is set by the small rear panel trim, and is not affected by the **Master** knob.
21. **XLR Balanced Outputs & Ground Lift:** These versatile connections are designed with Line 6's exclusive A.I.R. II technology to give you the perfect pair of direct connections for live performance and studio recording sessions. See **Using Your Direct XLR Outputs** on page 2•15 for details. Try flipping the Ground Lift switch if you are experiencing buzzing or hum when connected to other equipment via the **Direct XLR Outs**.

Please Note: there can be an audible 'pop' on the XLR outputs when powering your HD 147 on or off. We recommend that you either disconnect the direct outputs or power down whatever the direct outs are connected to before turning your HD 147 On or Off.

Power Switch & Connector (not shown in diagram): These are on the side of the rear panel that's not included in the illustration. Connect the supplied power cable to your wall outlet, then flick the power switch to let the electrons in to do their stuff.

Speaker Cabinet Basics

2 • 10

Be sure to turn the amplifier off when connecting or disconnecting speaker cables and cabinets. (This protects both the amplifier and the speakers.)

Use only heavy gauge, unshielded cables for hooking up speaker cabinets. (Do not use standard guitar cables to connect speaker cabinets, as they will degrade your sound.)

Take a Load Off!

While you would never want to operate a tube amplifier without a load (that means without speakers attached), operating the HD 147 without a load is OK! You do not need to have speakers connected to the amplifier in order to use the balanced Direct Outputs.

Volume Levels

Exercise some common sense about volume levels. The HD 147 can drive four 4x12 cabinets with power to spare, so it's got enough juice to fry the speakers of most setups if you really tried. If you see the speakers practically jump out through the speaker grille, back off on the HD 147's Master Volume a wee bit to get things back into the realm of reasonable operational levels. Also understand that Line 6 cannot be liable for replacement of speakers damaged by abuse. So, feel free to crank it up, but do it with a bit of sense and some regard for our speakers.

Setting the 4/16/18 Ohm Switch

It's important that you set your HD 147's rear panel 4/8/16 OHM switch to match the impedance of the cabinets that you are driving. You must match impedance to get the full volume and response, and to avoid overheating and shutting down the power amplifiers.

Sometimes the correct setting of the 4/8/16 OHM switch may not be immediately obvious. While most modern speaker cabinets (Like the Line 6 4x12) will clearly label their jacks with the impedance load that the speakers present to an amplifier, some vintage cabinets don't include impedance labeling. There are, fortunately, some general rules of thumb that you can usually rely on:

The first thing to know is that, due to the magical nature of electricity, the impedance load that a speaker cabinet creates depends on (1) the impedance of each speaker and (2) whether these speakers are hooked up in *series* or *parallel*. Series means that the speakers are wired up to the speaker jack in their cabinet so that electricity coming into

the jack from your HD 147 flows first into one speaker, and then into the next. Parallel means that the speakers are wired so that each has a direct connection to the jack, giving them each a direct connection to the electrical power supplied by your HD 147.

Typically, 2x12 cabinets are loaded with 8 ohm speakers. If they operate in mono, their internal wiring is generally done in parallel for a 4 ohm load. If they have a stereo option, this splits the speakers so that each acts as an 8 ohm load.

- To use the HD 147 with this typical 2x12 cabinet in mono, you'd set the HD 147's 4/8/16 OHM switch to 4 ohms and connect only the HD 147's left/mono output to the single mono input of the cabinet.
- For stereo HD 147 operation with this typical 2x12 cabinet, you'd set the HD 147's 4/8/16 OHM switch to 8 ohms and connect cables from HD 147's left output to the speaker cabinets left input, and from HD 147's right output to the speaker cabinet's right input.

Most 4x12 cabinets are loaded with 16 ohm speakers. When they operate in mono, their internal wiring is generally done in a combination parallel/series configuration that adds up to a 16 ohm load. If they have a stereo option, this configures the speakers left/right so that each side acts as an 8 ohm load.

Line 6 4x12 cabs are loaded with 8 ohm speakers wired for a 4 or 16 ohm load when running stereo, and either 2 or 8 ohms in mono.

If you connect two cabinets that have the same impedance to the two Left jacks of your HD 147 or the two right jacks (but not one each to left and right), that side of the HD 147's power amp will be connected to the speakers in parallel, and the result will be an ohm load that is one half of the impedance of one speaker cabinet alone. For instance, if two 16 ohm 4x12 cabinets are connected to the left outputs (or the right ones) of your HD 147, the impedance of the combined cabinet setup is 8 ohms, and you should set the HD 147 rear panel 4/8/16 OHM switch to this setting.

See the following pages for illustrations of typical setups.

Hooking up your HD 147 in mono with single 4x12

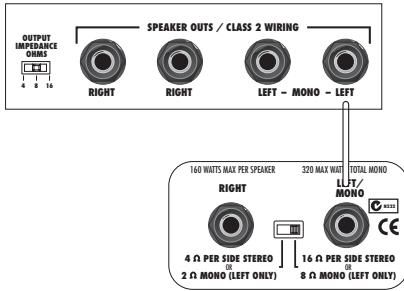

Hooking up your HD 147 in stereo with single 4x12

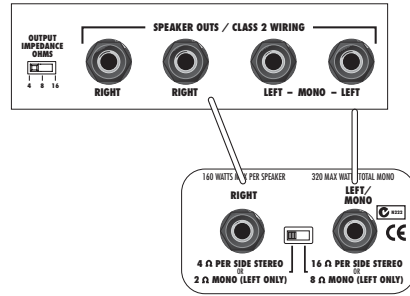

Hooking up your HD 147 in side by side stereo with two 4x12s

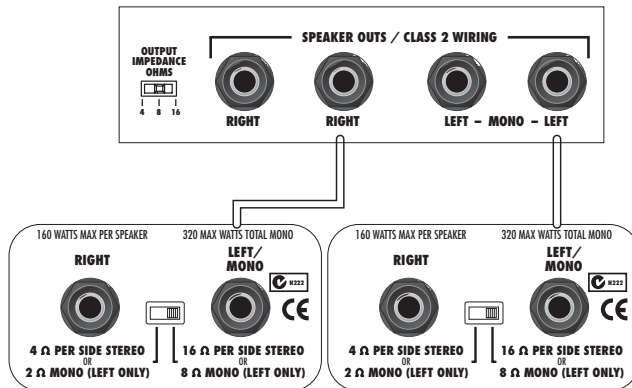

Hooking up your HD 147 in stacked stereo with two 4x12s

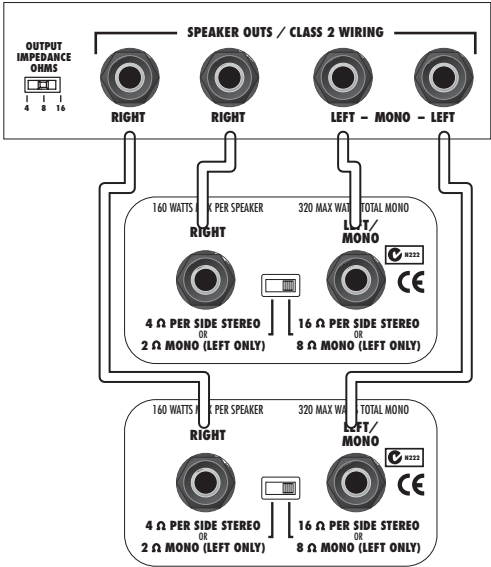

Hooking up your HD 147 to a single 2x12 in stereo.

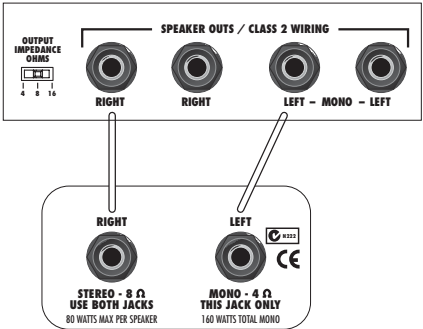

Hooking up your HD 147 in side by side stereo with two 2x12s.

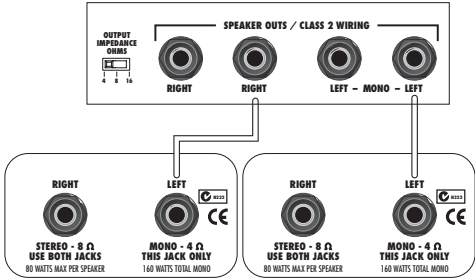

HD 147 through four 4x12s

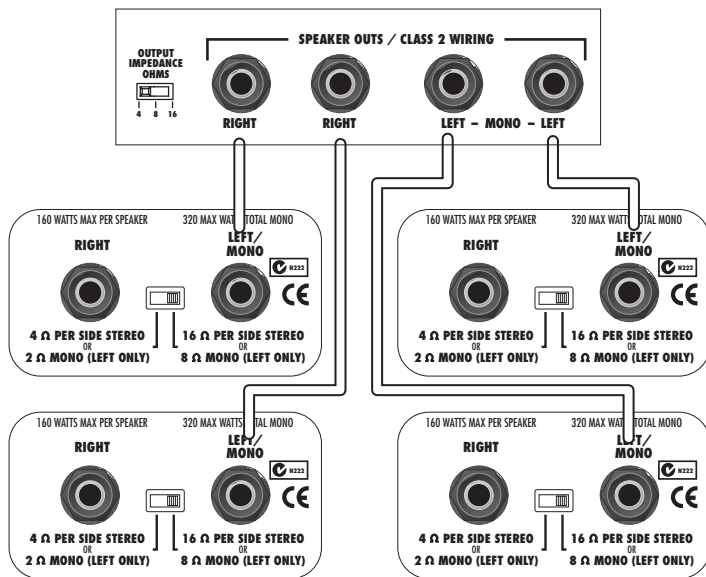

Using Your Direct XLR Outputs

One of the nifty features inside your HD 147 is Line 6's exclusive A.I.R. II technology that enables you to get that great mic'd up sound out of your amplifier without the microphone! Your Direct outputs can be used either in the studio or as a direct feed to the house sound system for a live performance.

2 • 15

The **Master** knob on your HD 147 sets the level for the internal speakers (and any external speakers you connect), without having any effect on your Direct Output level. This is a good thing, for instance, when you're playing live. It means you can set a low volume level for your amp on stage (maybe it's a small venue) while still pumping out full level at the direct outs so the house sound system is getting plenty of juice. And any adjustments you make to your on-stage level during the gig don't send the sound man scrambling to compensate on his end. This is also a good thing if you're recording in the studio, using your amp to monitor with the other band members while your direct out is being recorded. Once again, an appropriately low master volume level that you might want for the amp doesn't force you to have a low level signal going to tape, and adjustments you make to your level don't interfere with the levels in the control room.

HD 147 can send enough direct out level to light up the input meters for +4 dBu pro recording. For live sound systems, as well as many recording setups designed to work with lower levels, this can sometimes be overkill. The **Level Trim** knob on HD 147's rear panel lets you roll back the direct out level and keep your sound guy or lower-level recording system happy.

If you're setting the levels yourself, and want to make sure you don't overdo it, you can follow these basic steps. First, plug the hottest output level guitar you plan to use into your HD 147, switch to your hottest pickup setting, and crank the guitar's output volume (or put it as high as you ever set it). If you plan to change sounds on your HD 147 during the gig, start by selecting the HD 147 sound that seems to have the loudest output level. You can set your **Master** knob on HD 147 low as you do all this so you don't blow yourself out; it won't affect the direct output level. Now, with this guitar and HD 147 setup, play hard (so you're sending maximum volume out those direct outputs) and have someone adjust HD 147's rear panel **Level Trim** knob until a good healthy level is being received by the equipment you're sending sound to. The level shouldn't be so hot that it's causing input distortion or clipping on that receiving equipment. If the receiving equipment has an input level adjustment, you'll probably get your best signal-to-noise ratio by setting it as *low* as possible while setting your HD 147's **Level Trim** as *high* as possible.

THE AMPS & CABS

HD 147's heart is its collection of Amp and Cab Models—resulting from Line 6's meticulous study of a dream collection of vintage and modern amplifiers and cabinets. Each position of HD 147's **Model** knobs calls up a particular Amp/Cab combination, powered by many of the same coveted models that appear in the Line 6 Vetta series amps as well as PODXT.

3 • 1

What's In There

Line 6 Clean

To create this Amp Model, we essentially grafted the preamp and tone stack of a JC-120 (Roland's popular "Jazz Chorus" solid state combo) onto the power amp and transformer of a classic Marshall JTM-45 tube head, thereby giving you the crisp and clear front end typical of a solid state amp, but with a rich, satisfying tube amp-style bite as you turn it up.

Line 6 Super Clean (Red alternate model for "Line 6 Clean")

Forget what you know about how clean or how bright a guitar amplifier can go. Line 6 Super Clean goes farther, adding a *lot* of brightness. While this model is both Sparkley and Clean it has two other fun tricks up its sleeve as well: Setting the Drive knob at max gives a really broken "small amp on 10 about to die" sound. FUN! And the bass knob has an extreme effect when set to minimum— for sweet AM radio sounding tone.

Caution: Because Super Clean adds so much brightness, it generally won't work so well with distortion pedals, since they usually add lots of high frequencies, too. The combination may produce unnatural artifacts—or just rip your head off. Plug an undistorted guitar in here, though, and we're talking super happy shiny bright.

Line 6 Super Sparkle

You know how all great amps have a certain sweet spot — a particular setting where they sound magical — dripping with tone? Super Sparkle captures that organic vibe with a new twist: its voiced in the clean/low gain realm where everything usually sounds too clinical or too dark. Super Sparkle is an edgy tone that will sparkle and shimmer if you treat her right. So play nice.

Line 6 Mood (Red alternate model for “Line 6 Super Sparkle”)

And here we give you a fantasia tone, based on our fondest memories of grunge guitar tones we have known and loved. You can almost here the Seattle rain tapping on a practice room window somewhere.

Line 6 Crunch

While having cousins marry is not such a good idea in real life, in the amp world, it can have a great payoff. Since the design of some early Marshall amps had a lot in common with the Fender Tweed Bassman circuitry, we wondered what it would be like if we took the preamp and tone stack of our JTM-45 and ran it into the power amp and transformer of our '58 Tweed Bassman. Point, click, cut, paste (it would be nice if it were really that easy, huh? We'd sure be able to get more sleep). What we got was *way* happening, as Line 6 Crunch will attest. Great grind and nice punch. A tone that the whole family can enjoy.

Line 6 Spinal Puppet (Red alternate model for “Line 6 Crunch”)

The monster truck of tone. Big, powerful, tight and fast. We studied some of the best stock and modded Marshalls in the world to create this hybrid monster that goes *way* past 11. This is all about serious amounts of gain for discerning high gain players.

Line 6 Insane

Imagine running your Boogie Dual Rectifier as a preamp for your Triple Rectifier, and you've got a pretty good picture of just how much sheer gain is involved in Line 6 Insane. It's entirely possible to get completely out of control with this one, and we heartily encourage you to do just that.

Line 6 Purge (Red alternate model for “Line 6 Insane”)

We took our model of a Marshall JMP-1 preamp and hot-rodged it. It was hard work sticking in that digital dual overhead cam and hooking up the virtual glasspacks, but when we were done, we had the ultimate shred machine. Look out world, here you come.

Line 6 Smash

Got an axe to grind? Dial up Smash to take it way over the top with an obscene helping of gain. Smash delivers a tight bottom end, and a serious mid range void that'll render Hi-Fi, butt-kicking rhythm tone every time.

Line 6 Big Bottom (Red alternate model for “Line 6 Smash”)

Just can seem to get enough bottom end out of your cabinet? Try punishing it with Big Bottom. We crossed a Boogie Triple Rectifier with a Rivera Los Lobottom sub rig and dialed it in for serious disembowelment. But it's not just about the bass. A super wide midrange control and an extra present high midrange maintain articulation and power throughout the tonal range of this amp.

Line 6 Octone

Now here's something we hope you'll really like. What would it be like if you built a tube-based Octave Distortion preamp for a Class A poweramp? Line 6 Octone provides the answer. You'd get an Octave box that tracks better than anything you've ever used, deals with consonant intervals with a degree of panache that just wasn't possible before, and kicks some major rock and roll butt!

Line 6 Agro (Red alternate model for “Line 6 Octone”)

An aggressive high gain amp with a unique Mid control that will take you though the entire gamut of tone on one knob. How did we do it? The mid knob for this model changes the character of the distortion. When set to minimum the distortion exhibits Fuzz pedal characteristics. When the Mid is set to noon it creates creamy modern high gain amp tones a la Soldano. And when the Mid knob is turned up to Max it's very much reminiscent of that Class A Vox sound. Of course, then there are all the places in between...

Line 6 Treadplate

The original POD had a popular amp model simply called Rectified. It was our best attempt at the time to pay homage to the Mesa Boogie Rectifier series of amplifiers. In addition to the Boogie vibe, that model had some unique qualities that were all its own, and which we've captured here. In a way, Treadplate marks the first time we've actually modeled another Line 6 product! Here is an excerpt from the old POD manual to describe it: *“...modeled after a 1994 Mesa Boogie Dual Rectifier Tremoverb. You can use this Amp Model to get that tight, high gain sound used by bands like Dream Theater or Metallica. Boogie made their mark in the late 70's and early 80's by adding master volumes and more gain stages to amps with Fender-style circuitry. You can hear the Fender heritage but with more “punch” in the mids. The Boogie Dual Rectifier's tone controls are post-distortion and, as with the tone sections of most of the amps we based our models on, the individual controls interact with each other and with the Drive.”*

Criminal based on the Peavey 5150 MkII

3 • 4



This is the alternate, “red light” model at the Line 6 Treadplate spot on the Model knob.

No doubt, Eddie Van Halen will forever be known as one of the premier rock guitarists of all time. His technique and tone inspired legions of young guitar players, a couple of EVH custom guitars and this Peavey amp. Apparently Eddie committed some serious time to tweaking the distortion, tone and control range of this amp until it played and sounded just right. Interesting enough, it goes way beyond the classic “brown sound” that Eddie famously coaxed out of walls of Marshalls, and takes you into some serious rhythmic shredding territory.

All product names are trademarks of their respective owners, which are in no way associated or affiliated with Line 6. These product names, descriptions and images are provided for the sole purpose of identifying the specific products that were studied during Line 6's sound model development.

Jazz Clean - based on a Roland JC-120



3 • 5

This Amp Model is modeled after the classic Roland JC-120.

This transistor amp was known for a strident clean sound and built-in stereo chorus. When using the JC-120 model, try cranking up the Treble for a shimmering clean sound that'll cut through just about any mix. It's also perfect for that 80's "new wave" sound (after all, it was Andy Summers' favorite amp with The Police).

You should also try setting all the tone controls at 12 o'clock for a darker jazz tone. It'll give you an essentially flat response, providing a balanced tone across the fretboard for jazz chord melodies or single-line phrasing.

All product names are trademarks of their respective owners, which are in no way associated or affiliated with Line 6. These product names, descriptions and images are provided for the sole purpose of identifying the specific products that were studied during Line 6's sound model development.

Class A-30 TB – based on a 1967 Vox AC-30 Top Boost



This is the alternate, “red light” model at the Jazz Clean spot on the Model knob.

Music was changing in the early '60s and guitarists were asking for more brilliance & twang. So the Jennings Company, makers of Vox amps, decided to add Treble and Bass controls (and an extra 12AX7 gain stage, incidentally) in addition to the Treble Cut knob it already had (which in actuality was a sliding bandpass filter); this additional circuit became known as Top Boost. On this Amp Model, HD 147's Mid control acts like the original Cut knob on the AC 30.

The AC 30 with Top Boost was the amp made famous by many British invasion bands. Much of the unique character of the Vox sound can be attributed to the Class A circuitry—Class A amps overdrive in a very different way than Class AB. Brian May of Queen, Mike Campbell of Tom Petty's Heartbreakers, and The Edge of U2 have all used classic AC 30s to make their music. Although often played fairly clean, a cranked AC 30 has a great saturated lead tone, a la Brian May on early Queen albums.

All product names are trademarks of their respective owners, which are in no way associated or affiliated with Line 6. These product names, descriptions and images are provided for the sole purpose of identifying the specific products that were studied during Line 6's sound model development.

Blackface Lux – based on a 1964 Fender Deluxe Reverb



3 • 7

The Holy Grail for many blues, country, and “roots” players has been a blackface Fender Deluxe Reverb. The particular amp we studied for modeling was built in 1964, and is truly one of the finest examples of what a Deluxe Reverb can be.

Most players love a Deluxe when it’s turned up to about 7 for a nice gritty sound that cleans up when you back off your guitar’s volume knob just a little. Notice how the tone control response changes as this Amp Model’s Drive is changed: clean settings are crisp and present, while more driven settings will mellow the high end. This is typical of what you get from a Deluxe and is nicely captured here.

The Deluxe itself has only Bass and Treble controls. The Mid knob of HD 147’s Blackface model lets you add some post-Amp Model midrange contouring when you want to expand on the Deluxe Reverb’s capabilities for a little more flexibility. And Presence adds, well, Presence. Set the Mid knob to its 12 o’clock position and the Presence knob to 0 for the classic Deluxe sound. Tweaked up right, this tone will cut through and sing.

All product names are trademarks of their respective owners, which are in no way associated or affiliated with Line 6. These product names, descriptions and images are provided for the sole purpose of identifying the specific products that were studied during Line 6’s sound model development.

Fender 1961 Tweed Champ

3 • 8



This is the alternate, “red light” model at the Blackface Lux spot on the Model knob.

Modeled after a 1961 Tweed Champ, this model has a great sound when the Drive is cranked (not bad clean, either). These amps were originally designed to be sold to beginners, but rock and rollers quickly discovered that you could get a great distorted sound at fairly low volume levels. Many of the classic guitar solos of the 50’s were recorded through a Champ. The Champ had no tone control, only volume. With your HD 147, it’s easy to get a classic Champ tone. Just leave the Bass, Mid and Treble controls parked at 12 o’clock, which means they are “flat,” making no contribution to the tone. Set Presence to 0, and it will also be letting the unadorned classic Champ tone through. When you’re ready to explore further sonic territory, spin those and work your magic.

Since the Champ’s only got one input jack, that’s what we plugged into as we burned the midnight oil making our model based on this puppy.

All product names are trademarks of their respective owners, which are in no way associated or affiliated with Line 6. These product names, descriptions and images are provided for the sole purpose of identifying the specific products that were studied during Line 6’s sound model development.

Double Verb – based on a 1965 Fender Twin Reverb



3 • 9

The classic blackface Fender Twin (in this case, a 1965 Twin) was a real workhorse. Everybody used it, from jazz and country players to serious rockers. I myself remember seeing Johnny Winter at a concert where both he and Rick Derringer—am I dating myself or what?—were using six Twins stacked in a pyramid. Each. We were in the second balcony and it was REALLY loud even all the way back there. The Twin has a lot of tonal flexibility and is at home in a great many different situations. It never gets extremely overdriven and dirty, mostly just louder—a lot louder.

With HD 147's killer spring reverb model, this is a great choice for the classic surf sound. Goose the reverb, crank up the volume, and get ready to party with Annette Funicello and the rest of the gang!

All product names are trademarks of their respective owners, which are in no way associated or affiliated with Line 6. These product names, descriptions and images are provided for the sole purpose of identifying the specific products that were studied during Line 6's sound model development.

Tweed B-man – based on a 1958 Fender Tweed Bassman



3 • 10

This is the alternate, “red light” model at the Double Verb spot on the Model knob.

The classic '58 Fender Bassman 4x10 combo was the amp that started it all—instant rock and roll tone. Originally a bass guitar amp, the Bassman became a Blues staple for 6-string guitarists thanks to its fat bottom end and the Fender twang on the top.

An interesting thing about the Bassman—and HD 147's Tweed 410 model—is just how interactive the Mid and Treble controls are. The Mid control isn't a bandpass, as in most tone control setups. Instead, it's almost like a second treble control. The two are additive, so if you're running the Mid knob higher than halfway up, you'll find the Treble control might give you more bright than you really want. On the other hand, when you turn the Mid knob down, you'll probably want to boost the Treble.

The Bassman, like many of the amps modeled by HD 147, didn't have a master volume, and you had to really crank it up to get the great tone it delivers at high volume. With HD 147, you can get that kind of tone at a bedroom or studio level—or through your headphones even—by cranking up the Drive knob. Give your best R&B licks a try with Drive set to about 4 or 5.

All product names are trademarks of their respective owners, which are in no way associated or affiliated with Line 6. These product names, descriptions and images are provided for the sole purpose of identifying the specific products that were studied during Line 6's sound model development.

Plexi Lead 100 - based on “Jumped” 1968 Marshall Super Lead



3 • 11

We literally scoured the world for this particular amp, finally finding a great example of a Super Lead languishing (we like to think fate preserved it for us) in Holland. One of the fun things you can do with a Plexi is take a short guitar cable and jumper channel I and channel II (as they're frequently numbered) together for a little extra saturation. Some guys loved this sound so much that they pulled the chassis and permanently wired a jumper into the amp. We modeled the Super Lead this way.



Hendrix used a Super Lead with the ‘lay down’ transformer unique to the 68 models, and Van Halen’s first two records also owed their “brown sound” to a ’68 Plexi. To get a nice crunch sound out of a Plexi, you crank all the volume and tone controls to 10. In keeping with our “make-it-sound-a-whole-lot-like-the-original” concept, diming all your knobs with HD 147’s Plexi Lead gets you pretty darned near the same thing.

All product names are trademarks of their respective owners, which are in no way associated or affiliated with Line 6. These product names, descriptions and images are provided for the sole purpose of identifying the specific products that were studied during Line 6’s sound model development.

Plexi 45 – based on a 1965 Marshall JTM-45



This is the alternate, “red light” model at the Plexi Lead 100 spot on the Model knob.

When the royal agents that we had dispatched to the UK found this particular amp, we instantly fell in love. The amp even has the original KT-66 tubes in it, still in great shape! It’s one of the finest examples of a JTM-45 we’ve ever heard, and it’s a constant battle at Line 6 to see who gets to take it home for the weekend.

Those interested in the genealogy of tone will be interested to note that the JTM-45 marked the beginning of Marshall’s transition from a mellower Fender-like tone to the distinctive, bright “crunchy” sound of the later Marshalls.

All product names are trademarks of their respective owners, which are in no way associated or affiliated with Line 6. These product names, descriptions and images are provided for the sole purpose of identifying the specific products that were studied during Line 6’s sound model development.

Brit J- 800 – based on a 1987 Marshall JCM 800



3 • 13

Turn to this Amp Model to conjure up tones of the coveted JCM 800, one of Marshall's most universally-acclaimed modern amps. This updated version of the Plexi continued Marshall's heritage with added gain and edge for a new generation of rock guitarists. One of the biggest differences here is that the tone controls are located after the preamp tubes, giving them more tone-sculpting effect at high gain settings. Some versions of the JCM 800, by the way, get their distortion by clipping a diode. The amp we modeled uses a tube for distortion.

The JCM 800 is, of course, the metal sound Marshall made famous. And although not many people play Marshalls clean, it is a great tone, so you should also be sure to check out this model with a low Drive setting. Of course, you can always pump up the drive and rage....

All product names are trademarks of their respective owners, which are in no way associated or affiliated with Line 6. These product names, descriptions and images are provided for the sole purpose of identifying the specific products that were studied during Line 6's sound model development.

Brit J-2000 – based on a Marshall JCM2000



This is the alternate, “red light” model at the Brit J-800 spot on the Model knob.

The JCM2000 captures the modern Marshall tone, by refining the JCM series into a multi-channel power house. Our recreation captures the OD2 channel, with the Deep switch kicked in on a 60W TSL. The JCM200 uses a quartet of ECC83 pre-amp tubes and a pair of EL34 output tubes.

All product names are trademarks of their respective owners, which are in no way associated or affiliated with Line 6. These product names, descriptions and images are provided for the sole purpose of identifying the specific products that were studied during Line 6's sound model development.

Connor 50 – based on a Cornford mk50h



3 • 15

The Cornford mk50h is a fine, British-made boutique amplifier that our very own Line 6 UK lads tipped us onto. The Cornford has a fair amount of gain and breaks up like a Marshall Plexi, but retains a certain clarity that is more typical of Vox amplifiers.

One odd thing about the Cornford is the fact that it actually runs its drive channel in series with the Clean channel. This provides for some unique interaction that we captured during our modeling process by sweeping both controls though their range at the same time, and tying all of this to your HD 147's Drive knob. Lower Drive settings give you a tone dominated by the clean channel tonalities. As you turn the knob up past noon, you'll be moving into it more progressive high gain territory.

All product names are trademarks of their respective owners, which are in no way associated or affiliated with Line 6. These product names, descriptions and images are provided for the sole purpose of identifying the specific products that were studied during Line 6's sound model development.

Brit Silver – based on 1985 Marshall Silver Jubilee



This is the alternate, “red light” model at the Connor 50 spot on the Model knob.

In 1987, to commemorate 25 years in the amp business, Jim Marshall introduced a limited edition collection of tube amps based on the 2203 and 2204 master volume designs. They were very distinctive products, with silver vinyl covering and chrome panels, known simply as the “25/50 Silver Jubilee” Series models. The Silver Jubilee models used a unique diode clipping stage for extra gain and a redesigned tone block to offer much more tonal variation than previous Marshalls.

Guns N’ Roses’ lead guitarist, Slash, is way into this amp. So much so, in fact, that Marshall reintroduced the 100 watt model as the “Slash Limited Edition Signature Amplifier” in 1996.

All product names are trademarks of their respective owners, which are in no way associated or affiliated with Line 6. These product names, descriptions and images are provided for the sole purpose of identifying the specific products that were studied during Line 6’s sound model development.

Treadplate – based on a 2001 Mesa Boogie Dual Rectifier



3 • 17

This Amp Model is based on a 2001 Mesa Boogie Dual Rectifier Solo Head.

The Dual Rectifier was part of Boogie's more modern, high gain approach. In contrast to the earlier Boogies, the Dual Rectifier's tone controls have more influence at high gain settings, so you can scoop the mids and increase the bottom end. This is a great model to try if you're looking for the aggressively high gain sound of much of today's modern rock.

All product names are trademarks of their respective owners, which are in no way associated or affiliated with Line 6. These product names, descriptions and images are provided for the sole purpose of identifying the specific products that were studied during Line 6's sound model development.

Diamond Plate – based on a Mesa Boogie 2001 Triple Rectifier

3 • 18



This is the alternate, “red light” model at the Recto Dual spot on the Model knob.

This model is based on the Channel 3 ‘Modern’ setting of a 2001 Mesa Boogie Triple Rectifier Solo Head. Rock and roll is all about excess, now, innit? If two are good, three have got to be better, especially if you like the spongy feel of sagging rectifier tubes. No need to be bashful. Plug in, dial up some volume, and have some fun.

As with the Dual Rectifier model, we used Channel 3 in its Modern mode, with the rear switches set to Bold and Tube for this.

All product names are trademarks of their respective owners, which are in no way associated or affiliated with Line 6. These product names, descriptions and images are provided for the sole purpose of identifying the specific products that were studied during Line 6’s sound model development.

Bomber Uber – based on a Bogner Uberschall



3 • 19

Much like the Bogner Extacy, which we're about to meet, the Uberschall dishes up serious tone for high gain players. This is a fabulous boutique amp with a focused high gain tone that'll cut through the band and soar overhead for days.

The Uberschall has a very unique Presence control that we did our best to model here. Unlike most presence controls that tend to shave off very high frequencies, the Uberschall presence knob messes with the whole recipe. Mids, treble, bass and presence will come in and out, effecting both the pre gain and post gain tonality. A tonal roller coaster ride brought to you by one of the tube amp world's finest designers.

All product names are trademarks of their respective owners, which are in no way associated or affiliated with Line 6. These product names, descriptions and images are provided for the sole purpose of identifying the specific products that were studied during Line 6's sound model development.

Bomber X-TC – based on a Bogner Extacy



This is the alternate, “red light” model at the Bomber Uber spot on the Model knob.

Reinhold Bogner was good enough to personally select and deliver a Bogner Extacy for use in crafting this model. Reinhold was designing and building amplifiers long before he left Germany in 1989 to move to Los Angeles. Once in the US, he quickly gained the trust of many influential players including Steve Stevens, Dann Huff, Allan Holdsworth, Mike Landau and Steve Vai. They all sought out his skill at modifying and custom-building their amps. Eddie Van Halen entrusted Reinhold to overhaul and revitalize Eddie’s #1 Marshall Plexi. We hear that Eddie was pleased.

The Extacy covers a wide range of tone, and you’ll find that your HD 147’s Bomber X-TC model lets you do much the same as you work the Drive knob, as well as your guitar’s volume knob. On the top end, this one’ll bark like a Plexi, or you can take it down through swampy crunch and finally arrive in the realm of lush clean tone. The Extacy is a really versatile amp from a really great guy, and we’re pleased that he helped us model it for your HD 147.

All product names are trademarks of their respective owners, which are in no way associated or affiliated with Line 6. These product names, descriptions and images are provided for the sole purpose of identifying the specific products that were studied during Line 6’s sound model development.

Deity Lead – based on a Diezel VH4



3 • 21

What is it about Deutchland and high gain guitar amplifiers? When we met Peter Diezel, and opened up the VH4 we new we were in the presence of a serious tone fanatic. The VH4 is the Ducati of high performance guitar amplifiers. Meticulous attention to every detail, and enough tone and power to not only take on but seriously destroy any competitor.

Some of the most serious players in the Metal genre have come to depend on their VH4's for tight, focused and perfectly refined tone. The VH4's tone lies somewhere between a Soldano SLO 100 and a Mesa Boogie Dual Rectifier. It is perfect for lead work, and when the drive is brought back to noon, affords some excellent rhythm tones as well. Our model captures channel 4 on this sublime beauty.

All product names are trademarks of their respective owners, which are in no way associated or affiliated with Line 6. These product names, descriptions and images are provided for the sole purpose of identifying the specific products that were studied during Line 6's sound model development.

Deity's Son – based on a Diezel Herbert



This is the alternate, “red light” model at the Deity spot on the Model knob.

After messing with the VH4 we knew you’d get into another amp from Peter Diezel. Herbert is one of those simple, ingenious designs. It is unique among amps in its ability to achieve an incredibly wide range of tone on a single channel. Your HD 147’s model is very faithful to the original in tone, but due to a couple extra knobs on the Herbert, we had to make a few choices for you. Our model tackles Channel 3 with the Deep control preset to 2 O’Clock. The original also had a Mid Cut Intensity knob — this is the magic control that affords this amp its serious tonal range. To bring you this same joy, we set Herbert’s Mid knob to about 2 o’clock when modeling the tone stack. That allowed us to offer you control of Herbert’s unique Mid Cut Intensity with your HD 147’s Mid knob. Treble, Bass, Presence and Gain all work as the original.

All product names are trademarks of their respective owners, which are in no way associated or affiliated with Line 6. These product names, descriptions and images are provided for the sole purpose of identifying the specific products that were studied during Line 6’s sound model development.

The Cabinets

Here's the list of speaker Cabinet Models you've got in HD 147:

Cab Size	The model was created through careful study of this actual cabinet:	Model Knob Position
0	Cabinet Modeling Bypass	Line 6 Clean
2x2	2 x 2" Fender Mini Twin	Line 6 Super Sparkle
1x8	1 x 8" Fender '61 Champ	Line 6 Crunch
1x12	1 x 12" Fender '64 Deluxe	Line 6 Insane
2x12	2 x 12" Roland JC-120	Line 6 Smash
2x12	2 x 12" Vox '67 AC-30	Line 6 Octone
2x12	2 x 12" Fender '65 Twin	Line 6 Treadplate
4x10	4 x 10" Fender '58 Bassman	Jazz Clean
4x12	4 x 12" Marshall '67 with Greenbacks 20's	Blackface Lux
4x12	4 x 12" Marshall '68 with Greenbacks 25's	Double Verb
4x12	4 x 12" Marshall with Celestion T75's	Plexi Lead 100
4x12	4 x 12" Marshall with Celestion V30's	Brit J-800
4X12	4 x 12" Marshall with 2V30's & 2T75's	Connor 50
4X12	4 x 12" Mesa Boogie with Extended Low End	Treadplate
4X12	4 x 12" Line 6 Custom	Bomber Uber
4x12	4 x 12" Mesa Boogie with Celestion V30's	Deity Lead

As described in Chapter 2, you can select a Cab Model by pressing and holding the **Model** knob. A green light will come on in the ring around the knob to show you what cab is currently selected. Turning the knob *while still pressing and holding it* will change the cabinet selection. The cabinets are organized from small to large. It all starts out small with the cab at the “Line 6 Super Sparkle” position and gets bigger as you go clockwise to the “Deity Lead” spot. Turn the knob to “Line 6 Clean” to disable the cab modeling. As you select Amp Models via the **Model** knob, HD 147 is loading an appropriate cab for each amp in the background so you don't have to. See **Creating Amp Defaults** on page 2•7 to learn how to change which cab will load with a particular Amp Model.

All product names are trademarks of their respective owners, which are in no way associated or affiliated with Line 6. These product names, descriptions and images are provided for the sole purpose of identifying the specific products that were studied during Line 6's sound model development.

THE EFFECTS

About the Delay and Modulation Effects

Welcome to the Effects section of our manual. Against our accountant's better judgment, we took the liberty of adapting a bunch of great stomp box models from Line 6's MM4 Modulation Modeler and DL4 Delay Modeler pedals, and stuffed them all into your HD 147.

Now you may be wondering, how it is that we were able to take all of the controls associated with cool effects like a Flanger or an Analog Delay and distill them down to a single Delay or Mod control? Well, we asked around and discovered that a lot of people like to run their effects in similar ways. For example, it's common when setting up a slap echo to turn the feedback down, while long delay times usually are accompanied by increased feedback. Similarly, with modulation its generally accepted that as the rate is increased, the depth needs to decrease in order for the perceived intensity of the effect to remain the same.

We used this knowledge to make the Delay and Mod knobs 'smart,' with each controlling a number of parameters as needed to give you a full range of usable sounds via just one control. Then, as described on page 2•5 and page 2•5, we threw in the ability to further fine-tune Delay Feedback as well as various aspects of the Mod effects. The result is great sounding effects that are also really easy to use!

So, why don't we learn about each of the effects in detail...

Delays

As detailed on page 2•5, you've got these controls for Delay:

Delay Select Button chooses from the Delay Models or turns Delay off

Delay Knob gives you more/less of the selected delay effect

Tap Tempo Button sets the delay time when you tap it

Or press and hold **Tap Tempo** and turn the **Delay Knob** to set delay time

For extra tweakability, press and hold the **Delay Select Button** and turn the **Delay Knob** to fine-tune just the Delay Feedback

4 • 2

Tube Echo - Maestro EP-1 Echoplex

The classic 1963 Maestro EP-1 was the first of a series of “Echoplex” designs distributed by the company, and made by Harris-Teller in Chicago. As touted in a Maestro advertisement, the Echoplex’s “...special effects range all the way from a controlled high speed reverberation to a full, throbbing echo”!

The main feature of the Echoplex design is a special cartridge of looped 1/4-inch audio tape that wraps past separate record and playback heads. The position of the playback head can be moved to adjust the delay time from 60 to 650 milliseconds.



If you listen closely, you can hear some wow and flutter in the delay sound of this model, just like you'd get on the wonderfully organic-sounding original.

All product names are trademarks of their respective owners, which are in no way associated or affiliated with Line 6. These product names, descriptions and images are provided for the sole purpose of identifying the specific products that were studied during Line 6's sound model development.



Tape Echo - Roland RE-101 Space Echo

Long before Boss pedals, the Space Echo was Roland's first venture into the world of effects processing. Rather than the single movable playback head of the Echoplex, this machine has multiple stationary heads that can all play back at the

same time to create its signature multi-tap delay effects. The Tape Echo in your HD 147 recreates this classic sound.

Analog - Electro-Harmonix Deluxe Memory Man

This model is based on the Electro-Harmonix Deluxe Memory Man and its classic analog echo "bucket brigade" electronics. This classic effect also has a chorus circuit that is applied to the echoes only, leaving the direct sound unaffected. The resulting warm, distorted tone and swimming echoes of the Memory Man appealed to many guitarists, and were an essential part of the guitar sounds for the first U2 album.



4 • 3

Digital

Straight up mono digital delay here, for basic echo-cho-cho-cho.

Ping-Pong

Ping pong Delay bounces the delays all around the stereo field. Our Ping Pong delay has two modes: when the Delay Knob is turned counter-clockwise past noon, your delay time is set to quarter notes on the left and straight eighth notes on the right for a more traditional stereo ping pong delay. Turning the delay Knob past noon gives you quarter notes on the left and dotted-eighths on the right for a classic U2 Edge sound.

Sweep Echo

Sweep Echo is a Line 6 original. It first appeared on our DL4 Delay Modeler and has turned out to be a special favorite amongst the many DL4 users that we've spoken to. It's kind of like a garden variety digital delay line with the unique addition of a sweeping resonant filter applied to the delayed signal. The Filter's Sweep rate is tied to Tap Tempo and will complete a cycle every two bars. "Warp speed, Scotty!"

All product names are trademarks of their respective owners, which are in no way associated or affiliated with Line 6. These product names, descriptions and images are provided for the sole purpose of identifying the specific products that were studied during Line 6's sound model development.

Modulations

As detailed on page 2•5, you've got these controls for Mod:

Mod Select Button chooses from the Mod Models or turns Mod off

Mod Knob gives you more/less of the selected mod effect

For extra tweakability, press and hold the **Mod Select Button** and turn the **Mod Knob** to fine-tune a **Modulation 2nd Function**.

4 • 4

Tremolo

This is based on the smooth, even-sounding tremolo circuits of blackface Fender amps like the '64 Deluxe and '65 Twin Reverb. They have a light bulb and a photo-resistor: when the light gets brighter, the tremolo gets louder. Adjusting the **Mod Knob** will change the speed and depth of the Tremolo from a smooth Fender sound to Ginsu knife-style chopping. The **Mod 2nd Function** adjusts the Depth.

Chorus

Here's big, beefy, extra wide, stereo sine wave modulated-chorus. This custom bad boy take cues from the greats like the Roland CE-1 and the TC Electronic SCF. Adjusting the **Mod knob** will affect the amount of Chorus, and scale the depth appropriately. Use the **Mod 2nd function** to adjust the Chorus Rate independently.



Flanger - A/DA Flanger

This is our model of the A/DA Flanger. Introduced in 1977, this stomp box's 35-to-1 sweep range and built-in compressor work together with the tone circuitry to create a signature jet-like sweep. It can be very dramatic with its unique wave shape and ability to create almost ring modulator-like effects at extreme settings. The **Mod knob** changes the amount of

Flange and scales depth and feedback though the range of subtle to extreme. Use the **Mod 2nd function** to adjust the Modulation Rate independently.

All product names are trademarks of their respective owners, which are in no way associated or affiliated with Line 6. These product names, descriptions and images are provided for the sole purpose of identifying the specific products that were studied during Line 6's sound model development.

Phaser - MXR Phase 90

The unassuming metal box pictured here is the phaser that changed the world—the MXR Phase 90. The Phase 90 is relatively subtle compared to other phasers, and when you use it, it becomes part of the overall guitar tone rather than trying to grab the spotlight all to itself. Its lush, organic, and groovy swirl can be heard all over the first two Van Halen albums, as well as Jimmy Page’s work on *Physical Graffiti*. The **Mod knob** adjusts the rate. Use the **MOD 2nd function** to adjust the Feedback independently.



U-Vibe - Uni-Vibe

The now-legendary Uni-Vibe was put on the map in 1969 by Jimi Hendrix. Essentially a four-stage phase shifter, the Uni-Vibe is best known for its watery texture and sultry tones. One listen to “Machine Gun” and you’ll know what we mean. Adjusting the **Mod knob** changes the rate. Use the **MOD 2nd function** to adjust the Depth independently.

Rotary - Leslie 145

Fine furniture and cool tones—the Leslie 145 gave you both at once. This tube-driven behemoth (you definitely *don’t* want to try picking one up on your own) features a belt-drive rotating high frequency horn along with a downwards facing 15-inch speaker that had a segmented drum spinning over it to disperse the sound. It was originally designed to be used with electric organs like the Hammond B3, but once guitarists (and even vocalists!) heard it, they just had to get in on the rotate-o-rama. The Leslie’s sole control is a fast/slow switch labeled Tremolo/Chorale. Setting the **Mod knob** below 12 O’Clock selects the slow setting, above noon, the fast. The **2nd function** adjusts the Tone.



All product names are trademarks of their respective owners, which are in no way associated or affiliated with Line 6. These product names, descriptions and images are provided for the sole purpose of identifying the specific products that were studied during Line 6’s sound model development.

USING YOUR FEET

FBV Class Foot Controllers

The optional FBV series foot controllers give you Wah and Volume pedal control plus the ability to name, store and recall thirty-six HD 147 Channel Memories.

The FBV series of foot controllers includes the original FBV—with its extensive effects controls for the Line 6 Vetta amps—and the more-compact FBV Shortboard, which includes all the controls needed for the HD 147. The Shortboard comes with a sticker that re-labels some of the controls that are used for non-HD 147 functions on other Line 6 products. We'll assume you've got that in place as we describe the Shortboard's functions here.

Note that the Line 6 Floor Board and FB4 foot controllers will not work with HD 147.

Connecting an FBV

Your FBV comes with an included RJ-45 cable. Connect this cable between the rear panel of the HD 147 and the rear panel of the FBV. The cable supplies power as well as communication, so there's no separate power supply required for the pedal.

If you ever need a replacement cable, look for a **Category 5, 10 Base-T or RJ-45 cable with male connectors on both ends.**

- “Category 5” refers to a 1 to 5 grading system for cable quality, with 5 being the highest quality. Get the good one.
- “10 Base-T” is a kind of computer network that uses these same cables.
- “RJ-45” is what you call the connectors on the ends of the cable.

If you're unsure if you've got the right thing, note that RJ-45 connectors basically look like a wide version of standard US telephone line connectors, with eight contacts instead of four.

Using Your Feet • So What Do All These Buttons and Pedals Do?

So What Do All These Buttons and Pedals Do?

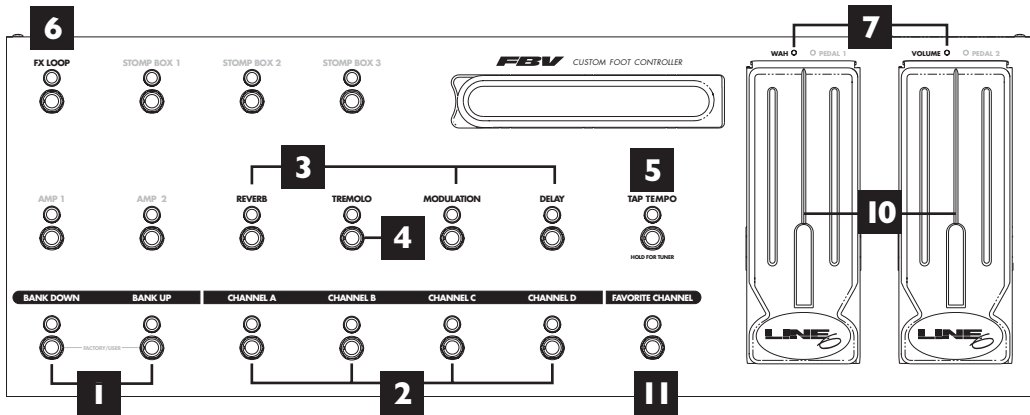
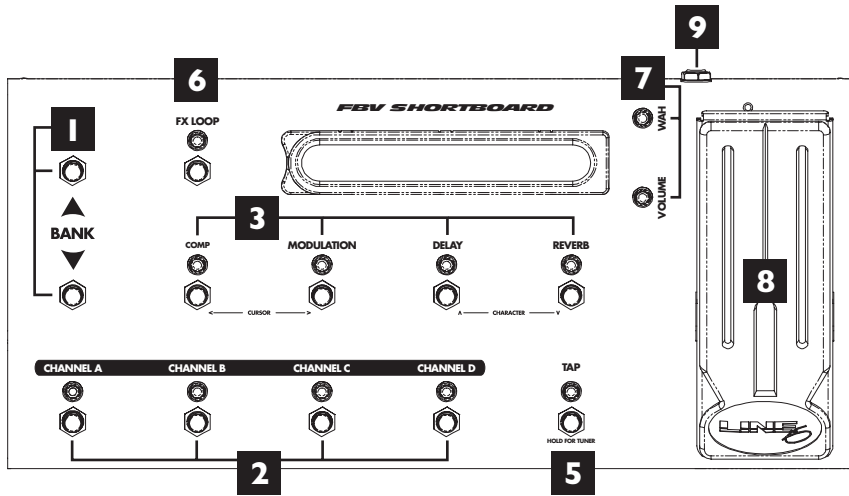

1. **Bank Up - Bank Down:** Use these two switches to choose any of the 9 Banks of your HD 147's Channel Memories. Bank 1 is the same four memories you get from the front panel **A, B, C, D Buttons** when no FBV is connected.
 2. **Channel A, B, C & D:** Select from the four Channel Memories in the current Bank.
 3. **COMP/MOD/DELAY/REVERB:** You guessed it! These switch the HD 147 effects COMP, MOD, DELAY and REVERB on and off kinda like they were stomp boxes on a pedal board. **Note:** *FBV Shortboard includes a sticker labeled "COMP" to place over the STOMP graphic on the pedal.*
 4. **TREMOLO (FBV only):** The Tremolo button on the FBV will turn HD 147's Compressor on/off. Contact our Customer Service department if you'd like a handy dandy sticker to re-label your FBV.
 5. **Tap/Tuner:** Tap a couple beats to set the tempo. Or press and hold this switch until you see the tuner on the pedal's display. Press it again to exit tuner mode.
 6. **FX Loop:** Turns HD 147's Effects Loop on or off.
 7. **Wah and Volume Lights:** These light to show that a pedal is ready to control Wah or Volume. The FBV's Pedal 1 and Pedal 2 lights are not used with the HD 147.
 8. **FBV Shortboard Pedal:** Press the pedal fully forward to click the toe-switch, switching the pedal to control Wah or Volume. If a separate expression pedal is connected to the Shortboard's rear panel 1/4-inch jack, the Shortboard pedal controls Wah only, with the toe switch toggling the Wah on/off.
 9. **External Pedal Jack:** You can connect an expression pedal (such as the Line 6 EX-1) to the Shortboard's rear panel 1/4-inch jack, and the connected pedal will control Volume, while the Shortboard pedal controls Wah only.
 10. **FBV Pedals:** Press a pedal forward to click the toe-switch, turning the pedal on/off.
 11. **Favorite Channel (FBV only):** Recalls a channel of your choice no matter what bank you are currently using. To make a channel your favorite, select that channel, then press and hold the favorite switch until the display shows "**SAVING**"—that's it!
- Note:** Any switches not being used by your HD 147 do send MIDI messages and can be used to control other devices. See the MIDI Appendix for details.

Flip the page for details on saving and naming HD 147 sounds with your FBV....

Saving and Naming with an FBV

To prepare for saving, it's a good idea to browse through the various factory-stored preset sounds to decide which you can do without. Make a note of their Bank number and Channel letter so you can save your own sounds there instead.

1. **Save:** Step on the **FX LOOP** switch until “**NAME EDIT**” is displayed.
2. **FBV SHORTBOARD users - Name:** The Shortboard's **COMP** and **MOD** switches (labeled **Cursor** in small text) select one of the characters of the channel name so you can edit it. The **DELAY** and **REVERB** switches (labeled **Character** in small text) choose from the available letters, numbers and symbols. Once you've got a name you're happy with, jump ahead to step 3.
2. **FBV Users - Name:** The **REVERB** and **TREMOLO** switches select which character of the channel name you would like to edit. The **MODULATION** and **DELAY** switches choose from the available letters, numbers and symbols. Once you've got a name you're happy with...
3. **Pick a Bank:** **Bank Up** and **Bank Down** switches pick a Bank you'd like to save to.
4. **Complete the Save:** Press the **A, B, C** or **D** switch to store to that Channel Memory in the chosen Bank. The display will show “**SAVING**”.

Congratulations, you're all done!

APPENDIX A: AMP MODELS

#	Amp Model	Based On	Cab Model	Mic	Vol Pre/Post	MIDI CC
1a	Line 6 Clean	Line 6 21st Century Clean	No Cab	SM-57 Off Axis	Pre	0
1b	Line6 Super Clean	Line6 Super Clean	No Cab	SM-57 Off Axis	Pre	16
2a	Line 6 Super Sparkle	Line 6 Super Sparkle	No Cab	SM-57 Off Axis	Pre	1
2b	Line 6 Mood	Line 6 Mood	No Cab	SM-57 Off Axis	Pre	17
3a	Line 6 Crunch	Line 6 Crunch	No Cab	SM-57 Off Axis	Pre	2
3b	Line 6 Spinal Puppet	Line 6 Spinal Puppet	No Cab	SM-57 Off Axis	Post	18
4a	Line 6 Insane	Line 6 Insane	No Cab	SM-57 Off Axis	Post	3
4b	Line 6 Purge	Line 6 Purge	No Cab	SM-57 Off Axis	Post	19
5a	Line 6 Smash	Line 6 Smash	No Cab	SM-57 Off Axis	Post	4
5b	Line 6 Big Bottom	Line 6 Big Bottom	No Cab	SM-57 Off Axis	Post	20
6a	Line 6 Octone	Line 6 Octone	No Cab	SM-57 Off Axis	Post	5
6b	Line 6 Agro	Line 6 Agro	No Cab	SM-57 Off Axis	Post	21
7a	Line 6 Treadplate	Line 6 Treadplate	No Cab	SM-57 Off Axis	Post	6
7b	Criminal	'02 Peavey 5150 Mk II	No Cab	SM-57 Off Axis	Post	22
8a	Jazz Clean	'87 Roland JC-120	2x12 Jazz	SM-57 Off Axis	Pre	7
8b	Class A-30TB	'63 Vox AC 30 with Top Boost	2x12 Class A	SM-57 Off Axis	Pre	23
9a	Blackface Lux	'64 Fender Deluxe	1x12 Blackface	SM-57 Off Axis	Pre	8
9b	Tiny Tweed	'61 Fender Champ	1x8 Tweed	SM-57 Off Axis	Pre	24
10a	Double Verb	'65 Blackface Fender Twin	2x12 Blackface	SM-57 Off Axis	Pre	9
10b	Tweed B-Man	'58 Fender Bassman	4x10 Tweed	SM-57 Off Axis	Pre	25
11a	Plexi Lead 100	'68 Marshall 'Plexi' Super Lead	No Cab	SM-57 Off Axis	Post	10
11b	Plexi 45	'65 Marshall JTM-45	No Cab	SM-57 Off Axis	Pre	26
12a	Brit J-800	'90 Marshall JCM-800	No Cab	SM-57 Off Axis	Post	11
12b	Brit J-2000	'00 Marshall TSL60	No Cab	SM-57 Off Axis	Post	27
13a	Connor 50	'02 Cornford mk50h	No Cab	SM-57 Off Axis	Post	12
13b	Brit Silver	'85 Marshall Silver Jubilee	No Cab	SM-57 Off Axis	Post	28
14a	Treadplate	'01 Mesa Boogie Dual Rectifier	No Cab	SM-57 Off Axis	Post	13
14b	Diamond Plate	'02 Mesa Boogie Triple Rectifier	No Cab	SM-57 Off Axis	Post	29
15a	Bomber Uber	Bogner Überschall	No Cab	SM-57 Off Axis	Post	14
15b	Bomber X-TC	Bogner Extacy	No Cab	SM-57 Off Axis	Post	30
16a	Deity Lead	Diezel VH4	No Cab	SM-57 Off Axis	Post	15
16b	Deity's Son	Diezel Herbert	No Cab	SM-57 On Axis	Post	31

All product names are trademarks of their respective owners, which are in no way associated or affiliated with Line 6. These product names, descriptions and images are provided for the sole purpose of identifying the specific products that were studied during Line 6's sound model development.

APPENDIX B: CABINET MODELS

#	Cab Model	Based On	MIDI CC
1	No Cab	Cabinet Modeling Bypass	0
2	2x2 Mini	2 x 2" Fender Mini Twin	1
3	1x8 Tweed	1 x 8" Fender '61 Champ	2
4	1x12 Blackface	1 x 12" Fender '64 Deluxe	3
5	2x12 Jazz	2 x 12" Roland JC-120	4
6	2x12 Class A	2 x 12" Vox '67 AC-30	5
7	2x12 Blackface	2 x 12" Fender '65 Twin	6
8	4x10 Tweed	4 x 10" Fender '58 Bassman	7
9	4x12 Green 20's	4 x 12" Marshall '67 with Greenbacks 20's	8
10	4x12 Green 25's	4 x 12" Marshall '68 with Greenbacks 25's	9
11	4x12 Celest T75	4 x 12" Marshall with Celestion T75's	10
12	4x12 Celest V30	4 x 12" Marshall with Celestion V30's	11
13	4X12 X-Load	4 x 12" Marshall with 2V30's & 2T75's	12
14	4X12 Big Bottom	4 x 12" Mesa Boogie with Extended Low End	13
15	4X12 Custom	4 x 12" Line 6 Custom	14
16	4x12 Treadplate	4 x 12" Mesa Boogie with Celestion V30's	15

All product names are trademarks of their respective owners, which are in no way associated or affiliated with Line 6. These product names, descriptions and images are provided for the sole purpose of identifying the specific products that were studied during Line 6's sound model development.

APPENDIX C: MIDI

MIDI Channel

HD 147 always communicates on MIDI Channel 1.

MIDI Program Changes

MIDI Program Change Messages 0-36 can be used to select HD 147's Channel Memories or Manual Mode, and are sent by HD 147 to control MIDI effects, etc.:

MIDI Program Change	HD 147 Channel Memory
0	Manual Mode
1	1A
2	1B
3	1C
4	1D
5	2A
6	2B
7	2C
8	2D
9	3A
10	3B
11	3C
12	3D
13	4A
14	4B
15	4C
16	4D
17	5A
18	5B

MIDI Program Change	HD 147 Channel Memory
19	5C
20	5D
21	6A
22	6B
23	6C
24	6D
25	7A
26	7B
27	7C
28	7D
29	8A
30	8B
31	8C
32	8D
33	9A
34	9B
35	9C
36	9D
37	Tuner

Notes:

MIDI PC 0 puts the HD 147 in Manual mode. (See Chapter 2 for a description of Manual Mode).

MIDI PC37 toggles tuner mode on and off. This is only useful if you have a FBV series controller attached to your HD 147.

MIDI Sysex (Memory Dumps)

There are 3 special hidden functions on the Flexitone III that will transmit a Sysex message that can be recorded by a MIDI application, or sent to another Flexitone III amplifier.

1. Presets & Amp Setups – To transmit all of your custom presets and Amp Defaults: press and hold the **Tap Tempo, Comp & Mod Select** buttons while powering up the amp. Connect the MIDI out of the source amp to the MIDI In of your computer or another amp. (If you are connecting to another HD 147, you can power up the target amp normally.) Press the **Delay Select** button to send the message.

2. The Whole Enchilada – To transmit the entire memory of the amplifier including your custom presets, amp setups, and DSP software, (the brains behind the operation): press and hold the **Tap Tempo, Gate & Mod Select** buttons while powering up the amp. Connect the MIDI out of the source amp to the MIDI In of your computer or another amp. (If you are connecting to another HD 147, you can power up the target amp normally.) Press the **Mod Select** button to send the message.

3. The Edit Buffer – To transmit the current state of the amp, press and hold the **Tap Tempo** and any of the **A, B, C** or **D** buttons.

APPENDIX D: MIDI CONTINUOUS CONTROL

Amp Parameter	MIDI		MIDI CC Range			Notes
	TX	RX	CC#	Min	Max	
Amp Settings						
Amp Model Select	√	√	12	0	31	Loads Amp Model without Amp Model Defaults. Amp Models list gives CC values.
Amp Select		√	11	0	31	Loads Amp with Amp Defaults. Amp Models list gives CC values.
Drive	√	√	13	0	127	
Bass	√	√	14	0	127	
Mid	√	√	15	0	127	
Treble	√	√	16	0	127	
Presence	√	√	21	0	127	
Channel Volume	√	√	17	0	127	
Reverb Level	√	√	18	0	127	
A.I.R. Settings						
Cabinet Model	√	√	71	0	15	Cab Model list gives CC numbers.
A.I.R. II Model		√	70	0	127	Range = 0~6. See Note 1
Compressor						
Compression Gain		√	5	0	127	0 to +31dB
Compression Threshold	√	√	9	0	127	-63dB to 0dB
Comp Enable	√	√	26	0	127	0-63=Off, 64-127=On
Noise Gate						
Gate Threshold	√	√	23	0	96	0 to -96dB
Gate Decay Time		√	24	0	127	0=.1msecs; 127=2000msecs
Noise Gate Enable	√	√	22	0	127	0-63=Off, 64-127=On
Modulation						
Modulation Model	√	√	58	0	5	See note 2
Mod Tweak		√	3	0	127	Same as adjusting the Mod knob
Mod Param 1 (Speed)		√	29	0	127	Mod Speed
Mod Param 1 Dbl Precision		√	61	0	127	Mod Speed, Double Precision
Mod Param 1 Note value		√	51	1	13	See note 3
Mod Param 2		√	52	0	127	See note 4
Mod Param 3		√	53	0	127	See note 4
Mod Param 4		√	54	0	127	See note 4
Mod Volume/Mix		√	56	0	127	0 to 100%
Mod Pre/Post		√	57	0	127	0-63=Pre, 64-127=Post
Mod Enable	√	√	50	0	127	0-63=Off, 64-127=On

Note 1 - A.I.R. II Models: 0=A.I.R. II Off, 1=Shure SM 57on axis, 2=Shure SM 57off axis, 3=MD 421 on axis, 4=MD421 off axis, 5=U-67 on axis, 6= U-67 off axis

Note 2 - Modulation Models: 0= Tremolo, 1= Chorus, 2= Flanger, 3= Phaser, 4= U-Vibe, 5= Rotary

Note 3 - Note Values: 0 = Note Off, 1 = Whole, 2=Dotted Half, 3 =Half, 4=Half Triplet, 5=Dotted Quarter, 6 =Quarter, 7 =Quarter Triplet, 8 =Dotted Eighth, 9 =Eighth, 10 =Eighth Triplet, 11 =Dotted Sixteenth, 12=Sixteenth, 13=Sixteenth Triplet

Note 4 - Modulation Parameters: Some Mod models have unique parameters. All use P1 (parameter) for Speed. For Tremolo P2= Waveform; Chorus P2= Depth, P3= Bass, P4= Treble; Flanger P2= Depth, P3= Feedback, P4= Manual; Phaser P2= Feedback; U-Vibe P2= Depth; Rotary P2= Tone.

Appendix D: MIDI Continuous Control

Amp Parameter	MIDI		MIDI CC Range			Notes
	TX	RX	CC#	Min	Max	
Delay						
Delay Model	√	√	88	0	5	See Note 5
Delay Tweak		√	2	0	127	Same as adjusting the Delay knob
Delay Param 1 (Time)		√	30	0	127	Delay time
Delay Param 1 DbI Prec		√	62	0	127	Delay time, double-precision
Delay Param 1 Note value		√	31	1	13	See note 3
Delay Param 2 (Feedback)		√	33	0	127	See note 6
Delay Param 3		√	35	0	127	See note 6
Delay Param 4		√	85	0	127	See note 6
Delay Volume/Mix		√	34	0	127	0 to 100%
Delay Pre/Post		√	87	0	127	0-63=Pre, 64-127=Post
Delay Enable	√	√	28	0	127	0-63=Off, 64-127=On
Tempo Settings						
Tap Tempo MSB	√	√	89	0	127	30.0-960.0 BPM
Tap Tempo LSB	√	√	90	0	127	
Tap	√	√	64	0	127	64-127= a Tap
Reverb						
Reverb Enable	√	√	36	0	127	0-63=Off, 64-127=On
Reverb Model		√	37	0	15	Range = 0~15, see note 7
Reverb Decay		√	38	0	127	0.1 to 9.0sec
Reverb Pre-Delay		√	40	0	127	0 to 100ms
Reverb Tone		√	39	0	127	0 to 100%
Performance Controllers						
FX Loop Enable	√	√	107	0	127	0-63=Off, 64-127=On
Tuner Enable	√	√	69	0	127	0-63=Off, 64-127=On
Wah Enable	√	√	43	0	127	0-63=Off, 64-127=On
Wah Position	√	√	4	0	127	
Vol Pedal Position	√	√	7	0	127	
Volume PRE/POST	√	√	47	0	127	0~63 = Pre, 64~127 = Post
FBV Series Foot Controllers						
(FBV) Stomp Box 1	√		25	0	127	0-63=Off, 64-127=On
(FBV) Stomp Box 2	√		109	0	127	0-63=Off, 64-127=On
(FBV) Stomp Box 3	√		110	0	127	0-63=Off, 64-127=On
(FBV) Amp 1	√		111	0	127	0-63=Off, 64-127=On
(FBV) Amp 2	√		112	0	127	0-63=Off, 64-127=On
(FBV) Pitch/Tremolo	√		113	0	127	0-63=Off, 64-127=On
(FBV) Modulation	√		50	0	127	0-63=Off, 64-127=On
(FBV) Delay	√		28	0	127	0-63=Off, 64-127=On
(FBV) Reverb	√		36	0	127	0-63=Off, 64-127=On
(FBV) Tap	√		64	0	127	TX127

Note 5 - Delay Models: 0=Tube Echo, 1=Tape Echo, 2=Analog, 3=Digital, 4=Ping Pong, 5=Sweep Echo

Note 6 - Delay Parameters: All use P1 for Delay Time, P2 for Feedback; Tube Echo P3=Flutter, P4= Drive; Tape Echo P3= Heads, P4= Flutter; Analog & Digital P3= Bass, P4= Treble; Ping Pong P3= Offset, P4= Spread; Sweep Echo P3= Sweep Rate, P4= Sweep Depth **Note 7- Reverb Models:** 0= Deluxe Spring, 1= Twin Spring, 2= King Spring, 3= Small Room 1, 4= Tiled Room 5= Bright Room 1, 6= Dark Hall 1, 7= Medium Hall, 8= Really Large Hall, 9= Rich Chamber 1, 10= Rich Chamber 2, 11= Cavernous Chamber, 12= Slap Plate 1, 13= Plate, 14= Large Plate 1

APPENDIX E: CUSTOMER SERVICE

Before contacting the Line 6 Customer Service team, please take the time to look through this publication to see if it can answer your questions. Additional helpful information is on the Support page of the Line 6 web site (www.line6.com), including the searchable FAQTRAQ system which is often the fastest and easiest way to go answers.

Need to talk to an actual human on the Line 6 Customer Service team by phone? Have your serial number handy and take some notes for yourself before you call, so you remember everything you want to ask about. In the USA or Canada, you can contact Line 6 at (818) 575-3600, 8AM to 5PM Monday through Friday (Pacific Time). Outside the USA and Canada, please contact your distributor directly to arrange service. The list of Line 6 distributors is available on the Internet at www.line6.com.

To obtain factory service:

If a member of the Line 6 Customer Service Team determines that your HD 147 needs to be sent to Line 6 for service, you will be given a return authorization (RA) number. Products returned without an RA number will be returned to you at your sole expense. Pack the product in its original shipping carton and attach a description of the problem along with your name and a phone number where Line 6 can contact you if necessary. Ship the product insured and freight prepaid to Line 6 Customer Service, 6033 De Soto Avenue, Woodland Hills, CA 91367.

APPENDIX F: WARRANTY INFORMATION

LINE 6 LIMITED WARRANTY INFORMATION

Sending in your registration card allows us to register key information so that we may handle problems faster and inform you of advance information, upgrades and other news. Thanks in advance for filling out your registration card and sending it to us. And good luck in your music!

Line 6, Inc. (hereinafter "Line 6") warrants that your new Line 6 product, when purchased at an authorized Line 6 dealer in the United States of America ("USA") or Canada, shall be free of defects in materials and workmanship for a period of one (1) year from the original date of purchase. Please contact your dealer for information on warranty and service outside of the USA and Canada.

During the warranty period, Line 6 shall, at its sole option, either repair or replace any product that proves to be defective upon inspection by Line 6.

Line 6 reserves the right to update any unit returned for repair and to change or improve the design of the product at any time without notice. Line 6 reserves the right to use reconditioned parts and assemblies as warranty replacements for authorized repairs.

This warranty is extended to the original retail purchaser. This warranty can be transferred to anyone who may subsequently purchase this product provided that such transfer is made within the applicable warranty period and Line 6 is provided with all of the following items: (i) all warranty registration information (as set forth on the registration card) for the new owner, (ii) proof of the transfer within thirty (30) days of the transfer purchase, and (iii) a photocopy of the original sales receipt. Warranty coverage shall be determined by Line 6 in its sole discretion.

This is your sole warranty. Line 6 does not authorize any third party, including any dealer or sales representative, to assume any liability on behalf of Line 6 or to make any warranty for Line 6.

Line 6 may, at its option, require proof of original purchase date in the form of a dated copy of original authorized dealer's invoice or sales receipt.

Service and repairs of Line 6 products are to be performed only at the Line 6 factory or a Line 6 authorized service center. Line 6 may require advanced authorization of repairs to authorized service centers. Unauthorized service, repair or modification will void this warranty.

LINE 6 LIMITED WARRANTY INFORMATION

Sending in your registration card allows us to register key information so that we may handle problems faster and inform you of advance information, upgrades, and other news. Thanks in advance for filling out your registration card and sending it to us. And good luck in your music!

Line 6, Inc., warrants this product when purchased at an Authorized Line 6 Dealer in the United States of America or Canada, to be free of defects in materials and workmanship for a period of one year from the date of original purchase only upon completion and return of the Line 6 Warranty Registration form within 30 days from date of purchase. Please contact your distributor for information on warranty and service outside the USA and Canada. During the warranty period Line 6 shall, at its option, either repair or replace any product that proves to be defective upon inspection by Line 6. Line 6 reserves the right to update any unit returned for repair, and reserves the right to change or improve the design of the product at any time without notice. This warranty is extended to the original retail purchaser. This warranty can be transferred to anyone who may subsequently purchase this product within the applicable warranty period by providing Line 6 with all Warranty Registration information for the new owner and proof of transfer within 30 days of the purchase. Final determination of warranty coverage lies solely with Line 6. This is your sole warranty. Line 6 does not authorize any third party, including any dealer or sales representative, to assume any liability on behalf of Line 6 or to make any warranty for Line 6. Line 6 may, at its option, require proof of the original date of purchase in the form of a dated copy of the original authorized dealer's invoice or sales receipt. Service and repairs of Line 6 products are to be performed only at the factory (see below) unless otherwise authorized in advance by the Line 6 Service Department. Unauthorized service, repair or modification will void this warranty.

DISCLAIMER AND LIMITATION OF WARRANTY

THE FOREGOING WARRANTY IS THE ONLY WARRANTY GIVEN BY LINE 6 AND IS IN LIEU OF ALL OTHER WARRANTIES. ALL IMPLIED WARRANTIES, INCLUDING WARRANTIES OF MERCHANTABILITY AND FITNESS FOR ANY PARTICULAR PURPOSE, EXCEEDING THE SPECIFIC PROVISIONS OF THIS WARRANTY ARE HEREBY DISCLAIMED AND EXCLUDED FROM THIS WARRANTY. UPON EXPIRATION OF THE APPLICABLE EXPRESS WARRANTY PERIOD (1 YEAR), LINE 6 SHALL HAVE NO FURTHER WARRANTY OBLIGATION OF ANY KIND, EXPRESS OR IMPLIED. LINE 6 SHALL IN NO EVENT BE LIABLE FOR ANY SPECIAL, INCIDENTAL OR CONSEQUENTIAL DAMAGES SUFFERED BY THE PURCHASER OR ANY THIRD PARTY, INCLUDING WITHOUT LIMITATION, DAMAGES FOR LOSS OF PROFITS OR BUSINESS, OR DAMAGES RESULTING FROM USE OR PERFORMANCE OF THE PRODUCT, WHETHER IN CONTRACT OR IN TORT. LINE 6 SHALL NOT BE LIABLE FOR ANY EXPENSES, CLAIMS, OR SUITS ARISING OUT OF OR RELATING TO ANY OF THE FOREGOING. Some states do not allow the exclusion or limitation of implied warranties so some of the above limitations and exclusions may not apply to you. This warranty gives you specific legal rights, and you may also have other rights, which vary, from state to state. This warranty only applies to products sold and used in the USA and Canada. Line 6 shall not be liable for damages or loss resulting from the negligent or intentional acts of the shipper or its contracted affiliates. You should contact the shipper for proper claims procedures in the event of damage or loss resulting from shipment.