



Technical Training Manual

For:

A8-2 1x8" 15W

A8-5 1x12" 30W

A8-7 HD75 75W

REV. A

November, 2006

CONTENTS:

- I. REVISION COMMENTS
- II. DISASSEMBLY & ASSEMBLY TIPS
 - Guitar Input PCBA Installation
 - Speaker Cable Installation
 - User Interface (UI) Installation
 - Power Amp IC Replacement
- III. POWER SUPPLY CONVERSION
 - Transformer & Fuse Tables
- IV. SOFTWARE MODES
- V. THEORY OF OPERATION
 - Main PCBA
 - Front-End
 - 1) Analog Signal Input Circuit
 - 2) User Interface Circuit
 - 3) FBV (Floorboard) Circuit
 - Digital
 - 1) Digital Processing Circuit
 - 2) Digital Signal Detail
 - Analog Outputs
 - 1) DAC Output Circuit
 - 2) CD/MP3 Aux Input Circuit
 - 3) Headphone Circuit
 - Power Supply
 - Power Amp
 - Power Supply
- VI. TROUBLESHOOTING TIPS
 - Additional Troubleshooting Tips

I. Revision Comments

Revision	Changes	Date
A	Initial Release	Nov 9th 2006 - JB

II. DISASSEMBLY & ASSEMBLY TIPS:

Main PCBA Removal & Installation:

Upon Removal of the Main PCBA:

- 1) All nuts from each POT shaft, both ¼" jack nuts, and a single 6-32 screw (shown below) must be removed before the Main PCBA can be taken out of the chassis.

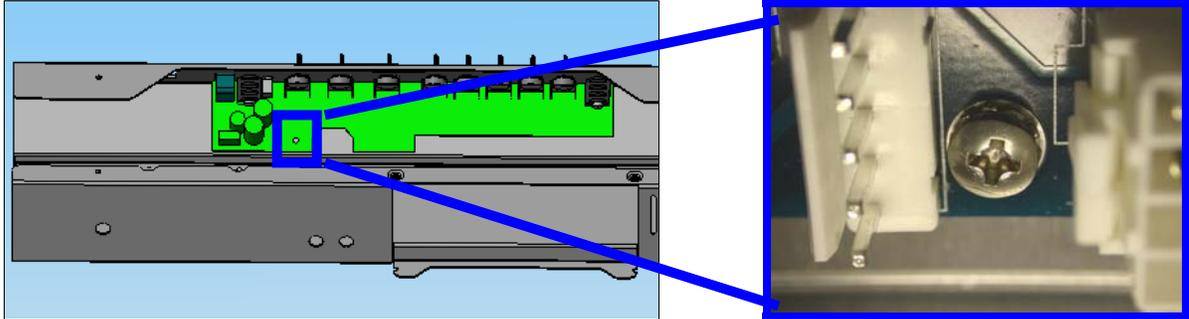

Upon Installation of the Main PCBA:

- 2) Make sure to only partially tighten the 6-32 screw shown above. Install both ¼" jack nuts followed by the all POT nuts and then the fully tighten the Main PCBA screw.

Power Amp IC replacement:

For the 1508 & 3012 models:

- 1) Install the Power Amp IC back on the chassis in the same order detailed below. Make sure that the Sil Pad is completely isolating the Power Amp IC from the chassis! It is recommended using a DMM to ensure no shorts exist.



For the HD75 model:

- 1) Make sure that the Sil Pads are completely isolating the Power Amp TDA7293 IC's (P/N 12-30-7293).

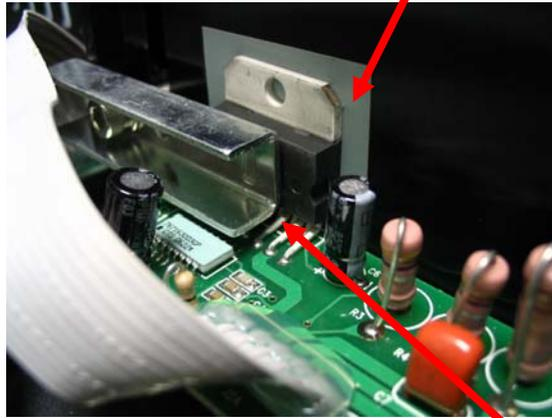

- 2) Make sure the support bracket is installed tightly and does not touch any of the Power Amp IC pins.

III. POWER SUPPLY CONVERSION:

Use the table below to determine the correct fuse value and transformer to install.

Description	Transformer	Fuse	Unused Transformer Wire
SPIDER 3 15W (A8-2) US	11-30-0015	1.0A 250V (24-19-0002)	Yellow Wire
SPIDER 3 15W (A8-2) AU	11-30-0016	0.5A 250V (24-19-5000)	Yellow Wire
SPIDER 3 15W (A8-2) EU	11-30-0016	0.5A 250V (24-19-5000)	Red Wire
SPIDER 3 15W (A8-2) JA	11-30-0015	1.0A 250V (24-19-0002)	Red Wire
SPIDER 3 15W (A8-2) UK	11-30-0016	0.5A 250V (24-19-5000)	Yellow Wire

Description	Transformer	Fuse	Unused Transformer Wire
SPIDER 3 30W (A8-5) US	11-30-0013	1.0A 250V (24-19-0002)	Yellow Wire
SPIDER 3 30W (A8-5) AU	11-30-0014	0.5A 250V (24-19-5000)	Yellow Wire
SPIDER 3 30W (A8-5) EU	11-30-0014	0.5A 250V (24-19-5000)	Red Wire
SPIDER 3 30W (A8-5) JA	11-30-0013	1.0A 250V (24-19-0002)	Red Wire
SPIDER 3 30W (A8-5) UK	11-30-0014	0.5A 250V (24-19-5000)	Yellow Wire

Description	Transformer	Fuse	Unused Transformer Wire
SPIDER 3 HD75 (A8-7) US	11-30-0025	4A 125V (24-19-4025)	Yellow Wire
SPIDER 3 HD75 (A8-7) AU	11-30-0026	2A 250V (24-18-2251)	Yellow Wire
SPIDER 3 HD75 (A8-7) EU	11-30-0026	2A 250V (24-18-2251)	Red Wire
SPIDER 3 HD75 (A8-7) JA	11-30-0025	4A 125V (24-19-4025)	Red Wire
SPIDER 3 HD75 (A8-7) UK	11-30-0026	2A 250V (24-18-2251)	Yellow Wire

WARNING! TO PREVENT RISK OF FIRE REPLACE WITH THE SAME TYPE FUSE AS IS CALLED OUT IN THE TABLES ABOVE.

If a Power conversion is completed, always make sure the unused transformer terminal is taped and a zip tie added as shown below!



IV. SOFTWARE MODES

During Power up hold the following buttons:

- Channel A: Reinitialize
- Channel B: Firmware Rev # check.

For example, if the software version is 1.04 then the Channel B button will light once, the Channel C zero times, and the Channel D button four times.



- Channel C: None
- Channel D: None
- TUNER: Self Test Mode = True audio bypass at full volume
No effects, amp models, EQ, etc.
Use for Button and POT functionality tests.

V. THEORY OF OPERATION

The Spider 3 1508, 3012, and HD75 Main PCBA are identical with exception to the stuffing options.

- The 1508 has no crystal Y1, no crystal buffer U12, and no FBV circuitry stuffed.
- The 3012 has all components stuffed.
- The HD75 is identical to the 3012 with exception to:
 - All on-board Power Amp components have been removed, an external Power Amp PCBA with Heat sink is attached to chassis rear instead.
 - Several Power Supply components have been “upgraded” to higher power ratings.

MAIN PCBA:

Front-End:

1. Signal Input Section (Main PCBA):

a.) *Analog detail (guitar):*

Analog guitar input signal enters the ¼" jack J1 and is referenced to ground by R1, which establishes a 1M-Ohm input impedance. Maximum input signal amplitude before clipping is approximately 5Vpp. The signal is then buffered at the voltage follower U1-A, no pre-emphasis or de-emphasis is used! The output of U1-A is split and sent to the input of U1-B as well as to the left input of codec U2. U1-B increases the "low gain" signal by +16 and sends the resulting "high gain" signal to the right input of codec U2.

The series capacitors C6-7 on each ADC input are used as "DC blocking" capacitors since the analog inputs of U2 are biased to approximately ½ of there analog supply, or 1.65V.

On the right "high gain" channel input to U2, diode D10 is used to "clamp" the voltage to a safe level of -0.6V to +(3.3VA+0.6)V since this channel is usually clipping with a nominal signal present at the input.

The ADC of U2 converts the left and right analog signals into digital signals, which are then sent to the DSP as ADC_DATA for processing. Only one of the signals is chosen for processing based on amplitude. Max voltage swing before clipping at the ADC inputs is approximately 2.0Vpp.

b.) *Analog detail (CD/MP3):*

An auxiliary CD/MP3 input is provided by 3.55mm jack J2. The Left and Right input signals are equally summed to MONO per R45 and R47 and then summed with the processed guitar signal at the LPF gain stage U9-A, at the DAC outputs.

c.) *Digital detail:*

The only "digital" signal on the input circuit is GUITAR_SENSE. See *Section V: Theory of Operation - Digital Processing Circuit* for more detail.

d.) *EMI & ESD Detail:*

For the Guitar input:

C67, C72 with L9-10 and GF1 help to shunt HF noise to the chassis. D2 is a voltage clamp, and helps insure that ESD will not exceed the voltage rails of U1. R2 provides over-voltage current limiting for both D2 and U1. All components combined provide a low-impedance HF shunt to chassis ground for ESD.

For the CD/MP3 input:

C47-49 combined with L1-2 and L8 provide both EMI and ESD protection.

2. User Interface PCBA:

Buttons & LED's:

Only 5 LED's and 5 Switches are located on the UI PCBA, each with a single resistor for current limiting. All signals run directly to the ADC's of the MCU U3 via

the ribbon cable from H6 to H1. The +3.3V is used as the power source and the MCU as the sink for all switches and LED's.

3. FBV (Floorboard) Circuit (Main PCBA)*:

The floorboard includes one single-ended serial "receive" data line RXN and differential serial "transmit" data lines TXP and TXN along with a +8V power line (+VL) and ground, DGND. All data signals are buffered through U6 and tied to pins 17-18 of the MCU U3.

**Note: The 1508 model has no FBV components stuffed!*

a.) ESD/EMI Detail:

Inductors L3-7 combined with C39-43 and diodes D25-27 provide both ESD and EMI protection. R39 provides additional protection to prevent damage at U6.

4. JTAG Circuit (Main PCBA):

The JTAG port of the DSP is available through the uninstalled H2 header. This connection is used for development and in-house software upgrades.

Digital:

1. Digital Processing Section (Main PCBA):

a.) Audio Signal Detail (ADC to DAC):

The ADC's of U2 sample the left and right analog signals at a rate of 39 kHz. The digital signals are then sent to the DSP U5 on the ADC_SDATA line for processing. Only one of the input signals is chosen to be processed by the DSP based on amplitude. The Codec Right input is chosen for processing if the signal is approximately 200mVpp or less. After further DSP processing is complete, the codec receives the processed digital audio signal at its serial data input DAC_SDATA. The codec then converts the digital signal into two single-ended analog outputs biased to half of the Analog Supply VA.

b.) Digital Signal detail:

Clocks:

For the 1508:

No crystal is stuffed, the master clock is generated internally by the MCU which feeds the DSP via the MASTER_CLK line. All sub clocks are provided by the DSP using MASTER_CLK and the PLL made up of the components connected to pins 31-32.

1508 Clocks:

Clocks:	Frequency:
M_CK (U3 internal)	3.6864 MHz
MCLK (256FS_CLK)	10.0 MHz
BCLK (64FS_CLK)	2.5 MHz
LR_CLK (FS_CLK)	39 kHz

For the 3012 & HD75:

The 12.000MHz master clock Y1 provides a highly accurate and stable oscillator for the DSP. All clocks are generated from this master clock using the PLL within the DSP, including the 100 MHz core clock. The filter for the PLL is made up of the components connected to pins 31-32 of the DSP (U5), as in the 1508.

3012 & HD75 Clocks:

Clocks:	Frequency:
M_CK (Y1)	12.000 MHz
MCLK (256FS_CLK)	10.0 MHz
BCLK (64FS_CLK)	2.5 MHz
LR_CLK (FS_CLK)	39 kHz

Memory:

There are two memory IC's connected to the DSP, the Flash U4 and the SRAM U7. The flash memory U4 holds the system code and is loaded into the DSP after the DSP is ordered to re-initialize by the MCU. The other memory, U7 is an SRAM, and is used for buffering processed audio signals.

Control & Sense Lines:

Master_Reset: Generated internally by the MCU and is active when Low. All other peripheral reset and enable signals are provided by the DSP U5.

DSP JTAG: The JTAG lines to the DSP are available through the uninstalled H2 header. This connection is used for development and in-house software upgrades.

Development Midi I/O: All lines to/from header H3 are used to interface with the MCU for development and programming of the MCU U3 and the Flash U4. The only way to update or reload code on a Spider 3 is with a Line 6 programming interface PCBA connected to this header. No updates should ever be necessary!

HP_SENSE:

For the 1508 & 3012:

At headphone plug in, R60 is left floating which introduces +HI at the + pin 7 of comparator U10-A. The voltage divider created by R57 and R62 creates a reference point that is below that of the + input when headphones are inserted. This forces U10-A output High, thus HP_SENSE active High. The DSP then registers the headphones are connected and incorporates cab modeling into +AUDIO_L.

For the HD75:

At headphone plug in, R43 is left floating which forces a steady +3.3V HP_SENSE active High signal. The DSP then responds by incorporating cab modeling into the +AUDIO_L signal. When the headphones are removed, the Power amp output is clamped to a max of 0.0-3.3V per D15 and current limited per

R43 and R60. The DSP recognizes this reduced alternating signal and registers no headphones are connected.

GUITAR_SENSE: GUITAR_SENSE is Low if there is no input. If a jack is plugged into J1 the line goes High (+3.3V) per pull-up resistor R37. The line runs directly to the DSP which “mutes” all guitar audio from the DAC if an input is not present. Note that CD/MP3 audio bypasses the DAC and will reach the headphones or the speaker (if headphones not present) regardless of the guitar input connection. The Power Amp Mute line is never active during normal operation for the HD75 model.

Analog Outputs:

1) DAC/CD/MP3 Output section:

The analog outputs of codec U2 are single-ended and have a DC bias of approximately $\frac{1}{2}$ of the VA supply, about 1.65V. The left and right DAC outs pass the DC blocking caps C14-45 and are then equally summed with the left and right CD/MP3 inputs per R45 and R47-49, providing a 3dB boost in noise performance. The resulting Mono signal passes to the negative input of LPF U9-A which provides a gain of 4.13. The 3dB frequency cutoff for the LPF is well above the audio pass-band ($f_c > 20\text{kHz}$) and is intended to reduce EMI. The resulting output of U9-A (+AUDIO_L) is single-ended, and in-phase with the system’s input. R59 serves as an analog volume control for both the headphones and the Speaker output. U9-B is configured as a buffer between the master volume and the power amp input.

2) Headphone Output (Main PCBA):

The Power Amp output OUTPUT_L+ feeds the Headphone outputs. R65 and 66 reduce the output of the power amp to a level more suitable for headphones. When the headphones are inserted the sleeve lifts the AGND_PA connection from OUTPUT_L- line running to the Speaker, which in turn mutes all Speaker Output.

a.) ESD/EMI Detail:

C44-46 combined with L11-12 and ground finger GF2 act as high frequency shunts to chassis ground for EMI and ESD. R43 and D15 are used to clamp the Power Amp output signal between 0-3.3V and feed it to the DSP as well as provide ESD protection.

b.) Digital detail:

The only “digital” signal on the headphones circuit is HP_SENSE. See *Section V: Theory of Operation - Digital Processing Circuit* for more detail.

POWER AMP PCBA:

- The Power Amp PCBA is identical for the Spider 3 1508 and 3012 with exception to the Power Amp IC U8. For the 1508 an 18W PA IC (12-30-2030) is stuffed and for the 3012 a 32W PA IC (12-30-2050) is used, both have identical footprints.

- The Power Amp PCBA for the HD75 is assembled with a finned aluminum heat sink external to the Main board and mounted to the chassis rear, it is NOT similar to the 1508 or 3012 models.
- The HD75 is the only model with a Speaker-Out PCBA attached to the Main PCBA header H4.

1) Input and feedback Circuit detail:

For the 1508 & 3012:

The Power Amplifier IC U8 has the mono +AUDIO_L signal fed to its negative input at pin 2. C21 blocks DC while R41 and R46 determine gain. C20 and C29 on the +/-HI_PA rails provide additional supply filtering. C24 in series with R52 helps suppress oscillation in case a speaker is not attached. R43 provides a current feedback path to help simulate the response of a tube amplifier. The ground of the speaker output is connected to the headphone jack J3 so that the speaker is disconnected when headphones are inserted.

For the HD75:

The TDA7293 Power Amp IC U2 has a mono +AUDIO_L signal fed to its' positive input at pin 3. The 0.22-Ohm resistors on the output help create a current feedback topology that provides a more tube like experience to the user. The input and feedback resistors made up of resistor network R10 are put in parallel to achieve values with less than 1% tolerance. The positive feedback 47pF cap and the negative feedback 68pF cap create LP filters to eliminate chances of high frequency oscillation. The 2.2-Ohm 2W resistor R6 and in series with C9 helps suppress high frequency oscillation in case a speaker is not connected. Minimum impedance for external speaker cabs is 8-Ohms per side.

a.) ESD/EMI detail:

For the 1508 & 3012:

C50-51 shunt high frequencies to chassis ground while C22 and C26 act as bypass caps.

For the HD75:

C20 and C24-26 shunt high frequencies to chassis ground at the Speaker Out jacks via GF1-2. C14-15 are bypass caps.

2) Speaker Out detail (HD75 only):

Both external Speaker Out jacks J5-6 are fed from the same OUTPUT_L+ signal. Inserting a second speaker only reduces the output impedance seen by the Power Amp.

b.) ESD/EMI detail:

Ground is provided by SPK_GND. GF1-2 provide a high frequency path to this ground via C20 and C25 for both ESD and EMI control.

POWER SUPPLY:

- The Power Supply is identical for the Spider 3 1508, 3012, and HD75 with exception to D28 and C35-36 on the HD75. The components on the HD75 are the same value as the 1508 and 3012 but are rated at higher power levels.

1) Primary Power Supply:

From the IEC AC connector input, the AC main ties directly to the rocker Power Switch and transformer primaries. No components are used for high frequency removal on the primary. Current is limited for safety fuse F1.

! Note that for continuous safety protection, all components connected to the AC main voltage must be replaced with Line 6 approved parts only; this includes the power switch, fuse, and all primary cables.

For the appropriate transformer, which primary cable to connect to, and the correct fuse values see *Section III: Power Supply Conversion*.

The transformer contains a thermal fuse, which will open the primary winding if the transformer core gets too hot. This fuse is not accessible; if it blows the transformer will need to be replaced. This should not happen under any normal conditions and the cause of the over-heating should be investigated before replacing the transformer.

The “hi-volt” secondary of the transformer provides approximately +/-15.2 rails for the 1508, +/-16.5 rails for the 3012, and +/-27.4 rails for the HD75, with grounded center tap. The lower voltage secondary for all three models is 7.2VAC.

2) Secondary Power Supply (Main PCBA):

All power for the 1508, 3012, and HD75 is supplied directly from the local power supply on the Main PCBA. There are 4 supplies derived from the Hi-volt secondary, they are the +/- HI rails and +/- VA. From the low volt secondary the +VL and +3.3V supplies are created. The +VL power line is approximately +10.5VDC depending on line levels and load currents.

The **+/-HI** rails are rectified by the full-wave diode bridge made up of D16-17 and D19-20 and filtered by C35-36. For the HD75 the bridge is replaced with an all-in-one diode bridge D28 and C35-36 are rated at 50V instead of 25V. The 47k-Ohm resistor R12 serves as a path for stored cap charge to “bleed” after power down. The +/- HI rails are filtered a second time at the Power Amp by C20, C22, C26, and C29 on the 1508 and 3012 and filtered by C14-15 on the HD75. The +/- HI rails directly supply the Power Amp IC’s only.

+/-VA are supplied by the +/-HI rails and are regulated to approx. +/-9V by Q1-2 on the 1508/3012 and by Q3-4 for the HD75. D13-14 provide +/-10V at the base of each transistor, ensuring both are always ON. R53 and R55 limit current and R54 and R61 help protect the collectors. C30 and C34 values were chosen in conjunction with R53 and R55 to provide a slow ramp up on power up to minimize turn-on pop at the speaker output. C31-32 are used for filtering only.

+VL is formed from the low volt secondary via the full-wave diode bridge made up of diodes D21-24 and filtered by C38. This directly supplies the optional foot controller for the 3012 and HD75 models only.

+3.3V is produced by U11, an adjustable voltage regulator supplied by +VL. The output of U11 is determined by resistors R63 and R64. D18 provides over-voltage and under-voltage protection while C28 and C37 provide filtering.

VI. Troubleshooting Guide:

This section outlines some common problems that may be encountered when troubleshooting a Spider 3 1508, 3012, or HD75.

1. Test points are provided on the SMD Components Side of the Main PCBA for all power supply voltages and clocks. Verifying these test points in the same order listed should always be the first step in troubleshooting. Next, all “sense” signals should be verified by probing at the correct nodes using a schematic.
2. The board powers up, the UI is displaying the correct items, the buttons and knobs work, but there is NO AUDIO.
 - First, check the audio input circuitry and make sure audio makes it through the input op-amp U1 all the way to the CODEC U2 inputs.
 - Second, make sure that the CODEC has the appropriate clocks driving it. In particular, make sure data exists on the ADC_SDATA and DAC_SDATA lines between the CODEC and the DSP U5.
 - Third, check the audio path from the output of the CODEC to the power amp and the headphone circuitry.
 - Fourth, check that the GUITAR_SENSE signal is HIGH when a jack is plugged into the guitar input. If this signal is not HIGH then the input jack J1 or the support circuitry for the sense line is faulty. If the system thinks that a cable is not plugged into the guitar jack it will automatically mute the audio from the CODEC. Audio from the CD/MP3 Input J2 bypasses the CODEC and runs to the headphone outputs without a guitar plugged in.
 - Fifth, if the audio is correct all the way to the CODEC, the clocks are correct, and the DAC_SDATA line is transmitting data when an input signal is present then it is possible the CODEC is malfunctioning. If the DAC_SDATA line is not OK than it's possible the DSP or an item on its bus is malfunctioning. At this point check for faulty soldering on the DSP or other items on its bus.
 - Sixth, the audio is correct all the way to the power amp but no audio out of the speaker. The headphone jack J3 mutes the Power Amp output to the speaker by removing the ground and should be checked. Note that the HP_SENSE line only changes the +AUDIO_L by enabling cab modeling for the headphones and does NOT change the audio level.

For the HD75 model only, if the +VA line is low, then the AMP_MUTE line will be active Low and mute Power Amp output. In this case the +HI supply as well as the +VA circuitry should be checked.

3. The LED's, POT's, and/or Buttons do NOT work.

First, check if you can get into Test Mode by powering up the unit while pressing the TAP TEMPO button (see *Section IV: Software Modes*). If you are able to get into Test Mode than any button pressed should have it's corresponding LED turn on. Each Pot movement should correspond to a particular LED surrounding the AMP MODELS POT lighting up and a unique pair of channel buttons turning on. Use the Test Mode to isolate any defective or damaged switch's or POT's.

If you are not able to get into Test Mode, check that the circuitry for the switches is functioning properly. In particular, check the ribbon cable from H6 on the Switch/LED PCBA to H1 on the Main PCBA. All lines from the LED's, POT's, and Buttons go directly to the MCU U3 ADC's on the Main PCBA. Check for bad soldering on U3 and that clocks/signals to/from the MCU are OK.
4. The board is running but the RJ-45 interface to the floorboard (FBV) does not work.

Check for faulty soldering and or defective SM resistors, inductors, and caps attached directly to the RJ45 lines. Next check the +9V power lines to the FBV. Verify that the signals are passing trough the buffer/inverter U6 properly. The MCU U3 should be checked next.
5. The Pots and Channels change by themselves.

Try to isolate pot and channel changes using the Test Software Mode described in *Section IV: Software Modes*. Next check the +3.3V line, if any ripple exists on this line the MCU will believe it is seeing command changes from the UI. The 1000uF C37 and 3300uF C28 caps on the +3.3V, all SMD caps on the Pots, and C29 and C65 on the MCU +3.3V line should be inspected for thorough filtering.
6. The Amp starts up and the LED's function properly but the version checking doesn't work and No audio passes.

The serial flash may not be programmed properly.
7. Settings are not being saved.

The FLASH memory on the Spider 3 MAIN PCBA is updated with any knob or button setting changes that occur at any time. If settings are not being saved, check for faulty soldering or components on the DSP's memory bus including the DSP U5, the FLASH U4, and the SRAM U7.

Additional Troubleshooting Tips:

- Pay attention to the fact that there is a bi-polar electrolytic cap C12 on the Power Amp PCBA of the HD75.

BOM Report 99-010-2505 - A8-2 Amplifier Spider 3 15 US 120V

Level	Item	Part Number	Qty	UOM	Refdes	Find	Rev	Description
1	10	21-37-1160	1					CBL PWR UL/CSA SJT 8.2FT BLK E L-302 w/GND EL70
1	20	40-00-0106	1					MANUAL USER STEELHEAD SPIDER3- 1508/3012/HD75 A8-2/A8-5/A8-7
1	27	40-00-0115	1			A		GUIDE POP-TOPPER SPIDER3-1508/ A8-2
1	30	40-00-1000	1			H		CARD WARRANTY LINE 6
1	40	40-01-0016	1			C		CARD LICENSE-AGREEMNT END-USER ALL-PRODUCTS
1	50	40-03-0031	1			B		CARD REGISTRATION UK
1	60	40-03-2000	1			F		CARD REGISTRATION US
1	70	40-03-2000-1	1			A		CARD REGISTRATION EUROPE
1	80	40-10-0104-1	1			C		CARTON GIFT SPIDER3-1508 A8-2 Rev.C
1	90	40-10-0106-1	1			B		CARTON SHIPPING SPIDER3-1508 A8-2
1	100	40-10-0117	1			A		INSERT HNDL-PROTEC 395mm x 210 mm X 3mm SPIDER2-1508
1	110	40-20-0011	1			A		BAG PLASTIC 10 x 16 2 mil
1	120	40-20-2525	1			A		BAG PLASTIC 25" x 25" 4-MIL
1	130	40-25-0024	1			B		STICKER ART SEAL EULA
1	135	40-25-0039	1			C		STICKER SPEAKER-GRILL PROMO SPIDER2-1508
1	150	40-25-0101	2					LABEL BAR CODE S/N 2-PNL LTX 16 1125502 MATTE WHITE
1	160	59-00-0021-5	1			A		ASSY UNIT COMPLETE SPIDER3 1508 A8-2 US 120V
2	1	11-20-0003	1					SPEAKER 8" 4 OHM 15W
3	10	40-25-0042	1			B		LABEL SPEAKER 8" 8-OHM 15W CHUNIL
2	2	21-34-0055	1		H4 MAIN TO SPEAKER	B		CBL ASSY 2 PIN 8.0" LG
2	3	21-34-1015	1					CBL FSTN .187-RCPT/.250-F FLAG 1-COND 161.34MM STRND 18AWG BK
2	4	30-00-0033	4					SCREW 10-24 x7/8 TRUSS HD PHH BLK
2	5	30-00-0043	2			A		SCREW 6-32 X 5/16 LG WITH LOCK WASHER PHIL PAN ZINC-PLATED STEEL
2	6	30-00-0375	3					SCREW 6-32 x .375 PPB
2	7	30-00-0402	1					SCREW #4 x 1/2IN SEMS w/EXT. TOOTH WASHER STL/ZNC
2	8	30-00-0676	2					SCREW WOOD NO.6 x 3/4" PHIL OVAL HD BLK
2	9	30-00-1020	4					SCREW 10-24 x 1-1/4 OVAL CTSK PB STL
2	10	30-00-1033	4					SCREW 10-32 x 3/8IN SCH STL BLK OXIDE
2	11	30-03-0112	4					WASHER FINISHING #10 FLANGED STL BLK OXIDE
2	12	30-03-0400	1					WASHER #4 SPLIT LOCKWASHER ZINC
2	13	30-03-0425	1					WASHER #4 0.125" ID x .233" OD .018 HEIGHT ZINC PLATE
2	14	30-06-0440	1					NUT HEX .242 4-40 STL/ZNC
2	15	30-06-0832	2					NUT .335 HEX 8-32 STL ZINC W/ TOOTH WASHER
2	16	30-15-0404	1					SHOULDER BUSHING TO-220
2	17	30-24-0003	3					CABLE TIE 4" CLEAR
2	18	30-27-0189	1			B		PANEL FRONT 13.8 X 2.8 X .70 ABS SPIDER3-1508 A8-2
3	10	41-00-0091	1			C		ARTWORK SILKSCREEN FRONT PANEL SPIDER3-1508 A8-2

2	19	30-27-0204	1
2	20	30-45-0011	8
2	21	30-51-0258	1
3	10	41-00-0084	1
2	22	30-63-1325	2
2	23	30-63-1550	2
2	24	30-63-4003	1
2	25	30-75-0020	1
2	26	30-75-9600	1
2	27	40-25-0015	1
2	28	40-25-0020	1
2	29	40-25-0029	1
2	30	40-25-0147	1
2	31	50-00-0001	1
3	1	21-14-0002	1
3	2	21-34-1116	1
2	32	50-03-0038	1
3	10	30-00-0061	5
3	20	30-00-0812	14
3	30	30-00-0858	5
3	50	30-00-1024	2
3	60	30-00-8112	3
3	70	30-03-0112	7
3	80	30-06-1024	6
3	90	30-28-0002	1
3	100	30-28-0003	1
3	110	30-28-0004	6
3	120	30-36-0005	2.5
3	130	30-39-0013	0.8
3	140	30-51-0188-1	1
3	150	30-57-0580	1
3	160	30-57-0581	2
3	170	30-63-0016	4
3	171	40-25-0083	1 EA
2	33	50-04-0037-1	1
3	10	11-30-0015	1
3	20	24-19-0002	1
3	30	50-02-0056	1
4	10	50-02-0058	1
5	5	01-16-0102	2

R65-R66

D	LOGO PLATE 9.4 x 1.8 x .26 ABS SILVER A8
D	KNOB POT .77 DIA x .76 HT PLASTIC CHROME PLATED
B	CHASSIS 13.8" X 5.9" X 3.3" ALUMINUM SPIDER3-1508 A8-2
D	ARTWORK SILKSCREEN CHASSIS REAR SPIDER3-1508 A8-2
	FOAM W/ADH. 13.25" x 0.25" x 0.06" VOLARAPOLELEFIN
	FOAM W/ADH. 15.50" x 0.25" x 0.06" VOLARAPOLELEFIN
	PAD THERMAL TO-220 TYPE: K6 BERG K6AC-58
D	KEYPAD RUBBER 6.74 x .57 x 0.23 BLACK SPIDER2
	GROMMET RUBBER 7/16-D x 1/16 GRV x 3/4" GRV-DIA BLACK
	LABEL GROUND SYMBOL
A	LABEL INSPECTION QUALITY
A	LABEL ETL SAITEK 2" x 1"
E	LABEL ETL SUGA 2"X 1" INTERTEK
A	ASSY RECEPTACLE-A/C W/GND WIRE SNAP-IN
	JACK IEC w/FUSE MALE 3 PIN PAN EL MOUNT SNAP IN VERT
C	CBL EARTHING w/EYELET 16AWG 5" GREEN w/YELLOW STRIPE
C	ASSY CABINET SPIDER3-1508 A8-2
	SCREW WOOD NO.6 x 1.0 FHP BLAC K OXIDE
	SCREW w/WAX 8 x 3/4 PTB
	SCREW #8 x 5/8IN PHIL-TRUSS BLACK w/WAX
	SCREW 10-24 x 1IN OVAL CTSK PPB STL WAXED
	SCREW WOOD #8 x 1 1/2" OVAL PH H STL BLK OXIDE
	WASHER FINISHING #10 FLANGED STL BLK OXIDE
	NUT-T 10-24 X 5/16 STEEL
	CORNER LEFT HI-DENSITY POLYETHYLENE TEXTURED BLACK
	CORNER RIGHT HI-DENSITY POLYETHYLENE TEXTURED BLACK
	CORNER BACK HI-DENSITY POLYETHYLENE TEXTURED BLACK
A	COVER VINYL TEXTURED BLACK SEMI GLOSS
	GRILL CLOTH BLACK SPIDER3
A	BRACE BAFFBOARD 13.8 x .90 x .69 EGS
A	HANDLE STRAP HEAVY DUTY BLACK
A	ENDCAPS BLACK TEXTURED FINISH
	FOAM w/ADHESIVE 8.0 x 1/4 x 1/16 VOLARAPOLELEFIN
4	STICKER CARB WOOD CABINET
	ASSY E/M CHASSIS SPIDER3-1508 A8-2 100V/120V
	XFMR 100/120VAC 15.2VAC x 2 / 7.2VAC SPIDER2-1508
	FUSE 1A 250V 5MM x 20mm FRNT
	PCBA PANELIZED MAIN/SW/PA SPIDER3-1508 A8-2
	PCBA MAIN SPIDER3-1508 A8-2
	RES CARBON FILM 1K 1/2W 5% TH

5	20	01-24-0000	1	R3	RES OR 1% 0805
5	30	01-24-1000	3	R54,R61,R64	RES 100R 1% 0805
5	40	01-24-1001	2	R2,R8	RES 1.00K 1% 0805
5	50	01-24-1002	5	R38-R39,R53,R55-R56	RES 10.0K 1% 0805
5	60	01-24-1003	1	R57	RES 100K 1% 0805
5	70	01-24-1004	3	R1,R58,R62	RES 1.00M 1% 0805
5	80	01-24-10R0	1	R34	RES 10.0R 1% 0805
5	90	01-24-1332	4	R45,R47-R49	RES 13.3K 1% 0805
5	100	01-24-1502	1	R7	RES 15.0K 1% 0805
5	110	01-24-1620	1	R63	RES 162R 1% 0805
5	120	1/24/1912	2	R22-R23	RES 19.1K 1% 0805
5	130	1/24/2002	2	R20-R21	RES 20.0K 1% 0805
5	140	01-24-22R1	3	R9-R10,R67	RES 22.1R 1% 0805
5	150	1/24/4751	7	R31-R33,R36-R37,R40,R60	RES 4.75K 1% 0805
5	160	1/24/4752	1	R27	RES 47.5K 1% 0805
5	170	1/24/5492	1	R44	RES 54.9K 1% 0805
5	180	01-24-5R11	2	R25-R26	RES 5.11R 1% 0805
5	190	01-25-0000	2	JP2-JP3 R11,R16-	RES OR 1% 0603
5	200	01-48-0001	8	R17,R24,R30,R35,R42,R59	POT MONO 10KB LINEAR 9MM/20MM D-SHFT HOR TH
5	210	03-10-0106	4	C4-C5,C10,C12	CAP ELEC 10uF 10V 20% RADIAL 5/11/2
5	220	03-10-0338	1	C28	CAP ELEC 3300uF 6.3V 20% RADIAL 10/20/5
5	225	03-10-1107	1	C82	CAP ELEC 100uF 6.3V 20% RADIAL 5/11/5
5	230	3/10/6108	2	C8,C37	CAP ELEC 1000uF 6.3V 20% RADIAL 8/11.5/5
5	240	03-12-0107	2	C30,C34	CAP ELEC 100uF 16V 20% RADIAL 6.3/11/5
5	250	03-12-0476	1	C18	CAP ELEC 47uF 16V 20% RADIAL 6.3/11.2/5
5	260	03-12-1338	1	C38	CAP ELEC 3300uF 16V 20% RADIAL 12.5/25/5
5	270	03-14-0228	2	C35-C36	CAP ELEC 2200uF 25V 20% RADIAL 12.5/25/5
5	280	03-18-0105	4	C6-C7,C14-C15	CAP ELEC 1uF 50V 20% RADIAL 5/11/5
5	290	03-18-0106	2	C31-C32	CAP ELEC 10uF 50V 20% RADIAL 5/11/5
5	300	03-50-0270	1	C23	CAP NPO 27pF 50V 5% 0805
5	310	03-52-0102	12	C44-C48,C50-C51,C73-C77 C9,C11,C13,C49,C53,C55-C60,C62-	CAP X7R 1nF 50V 10% 0805
5	320	03-52-0104	15	C65	CAP X7R 0.1uF 50V 10% 0805
5	330	03-52-0332	1	C16	CAP X7R 3.3nF 50V 10% 0805
5	340	03-52-0470	1	C72 C2-	CAP X7R 47pF 50V 10% 0805
5	350	03-52-0473	16	C3,C17,C19,C25,C27,C33,C52,C54, C61,C66-C71	CAP X7R 47nF 50V 10% 0805
5	360	6/4/4002	8	D16-D17,D19-D24	DIODE SMALL-SIGNAL 100V 30A DO-41 AXIAL TH 1N4002

5	370	06-23-0054	1	D10		DIODE SCHOTTKY DUAL 30V 200mA 5nS SOT-23 SM
5	380	6/28/8410	2	D13-D14		DIODE ZENER 10V 5% 350mW SOT-2 3 SM
5	390	06-34-0016	1	D15		DIODE SWITCHING 75V 200mA 6nS SOT-23 SM
5	400	06-34-0031	2	D2,D18		DIODE GEN PUR DUAL 120V 600mA 50nS SOT-23 SM
5	410	9/10/4401	1	Q2		TRANS NPN SMALL SIGNAL SOT-23 SM
5	420	9/10/4403	1	Q1		TRANS PNP SMALL SIGNAL SOT-23 SM
5	430	11/10/2012	7	L1-L2,L8-L12		FERRITE BEAD 600R @ 100MHz 300 mA 0805 SM
5	440	12-00-0317	1	U11	A	IC VREG ADJ 1.2V-37V 1.5 AMP TO-220 LM317 TH
5	450	12-54-0072	2	U1,U9		IC OP AMP DUAL TL072 SM
5	460	12-58-0339	1	U10		IC COMPARATOR QUAD LM339D SM
5	470	12-64-4552	1	U2		IC CONVERTER 3V 24 BIT 96KHz AUDIO CODEC AK4552 SM
5	480	15-62-0014	1	U6		IC 74HC14 HEX SCHMITT TRIGGER INVERTERS SO-14 SM
5	490	15-72-0001	1	U7		IC SRAM 256K x 8 BIT TSOP32 SM
5	500	15-86-0364	1	U5		IC DSP 24 BIT TQFP-100 SM
5	510	21-00-6616	2	J1,J3	B	JACK 1/4" TRS PCB MOUNT 6 PIN HORIZONTAL TH
5	520	21-12-0035	1	J2		JACK 3.5MM STEREO 5 PIN CRIMPE D LEADS NON-THREADED
5	530	21-20-0205	1	H3 (TEST ONLY)		HDR SIL PCB-MT 5 PIN x 2MM MAL E SHRD VERT MT TH
5	540	21-20-1564	1	H4		HDR SIL PCB-MT 4 PIN x .156 MA LE VERT MNT FRIC LOCK
5	550	21-20-1565	1	H5		HDR SIL PCB-MT 5 PIN x .156 MA LE VERT MNT FRIC LOCK
5	560	21-30-0014	1	JP2	A	CBL SIL 7 PIN 22AWG 2.54MM x 7 6MM S/T
5	570	21-30-0029	1	H1	A	CBL RIBBON DIL 14 PIN .100 PIT CH 2.0" STAKED TO FEMALE
5	580	30-18-3030	2	GF1-GF2		CLIP GROUND PCB .30 x .30 x .07
5	590	30-51-0146	1	SH1	A	SHIELD PCB MT FOR 1/4 JACK 1.00 Hx1.25Wx.013THK BERYL COP
5	600	35-00-0310	1		C	PCB MAIN SPIDER3-1508/3012 A8-2/A8-5 REV.C
5	615	45-01-0028	1	U3	V1.00	IC PROGRAMMED MCU v1.00 SPIDER3-1508 A8-2
6	10	15-84-0935	1		A	IC MCU 8KB FLASH P89LPC935 TSS OP-28 SM
5	620	45-02-0025	1	U4	V1.00	IC PROGRAMMED FLASH v1.00 SPIDER3-1508 A8-2
6	10	15-78-0005	1		A	IC FLASH 512Kb SPI SERIAL SOIC -8 SM
4	20	50-02-0060	1			PCBA POWER AMP SPIDER3-1508 A8-2
5	10	01-22-02R2	1	R52		RES METAL OXIDE 2.2R 2W 5% TH
5	20	01-22-0R22	1	R51		RES METAL OXIDE 0.22R 2W 5% TH
5	30	1/24/3241	1	R41		RES 3.24K 1% 0805
5	40	1/24/3921	1	R43		RES 3.92K 1% 0805
5	50	1/24/7502	1	R46		RES 75.0K 1% 0805
5	60	03-14-0107	2	C20,C29		CAP ELEC 100uF 25V 20% RADIAL 6.3/11.2/5
5	70	03-18-0106	1	C21		CAP ELEC 10uF 50V 20% RADIAL 5/11/5
5	80	03-52-0104	3	C22,C24,C26		CAP X7R 0.1uF 50V 10% 0805
5	90	12/30/2030	1	U8		IC POWER AMP 18W TDA2030A TO-2 20/5 TH
5	100	35-00-0310-2	1		C	PCB POWER AMP SPIDER3 1508/3012 A8-2/A8-5 REV.C
4	30	50-02-0310-1	1			PCBA SWITCH/LED SPIDER3 1508/3012 A8-2/A8-5

5	10	01-24-1300	5	R6,R13,R15,R19,R29	RES 130R 1% 0805
5	20	1/24/4751	5	R5,R12,R14,R18,R28	RES 4.75K 1% 0805
5	30	06-34-0016	5	D3,D5-D6,D9,D11	DIODE SWITCHING 75V 200mA 6nS SOT-23 SM
5	40	18-22-0003	5	D1,D4,D7-D8,D12	LED YELLOW SUPER BRIGHT 2MM x 1.25MM SM
5	50	21-21-0014	1	H6	HDR DIL PCB-MT 14 PIN 2 x 7 x .100 MALE SHRD VERT MNT TH
5	60	35-00-0310-1	1		C PCB SWITCH/LED SPIDER3 1508/3012 A8-2/A8-5 REV.C

BOM Report 99-010-2605 - A8-5 Amplifier Spider 3 30 US 120V

Level	Item	Part Number	Qty	UOM	Refdes	Find	Rev	Description
1	10	21-37-1160	1					CBL PWR UL/CSA SJT 8.2FT BLK E L-302 w/GND EL70
1	20	40-00-0106	1					MANUAL USER STEELHEAD SPIDER3- 1508/3012/HD75 A8-2/A8-5/A8-7
1	25	40-00-0109	1			A		GUIDE POP-TOPPER SPIDER3-1508/ 3012/HD75 A8-2/ A8-5/A8-7
1	40	40-00-1000	1			H		CARD WARRANTY LINE 6
1	50	40-01-0016	1			C		CARD LICENSE-AGREEMNT END-USER ALL-PRODUCTS
1	60	40-03-0031	1			B		CARD REGISTRATION UK
1	70	40-03-2000	1			F		CARD REGISTRATION US
1	80	40-03-2000-1	1			A		CARD REGISTRATION EUROPE
1	90	40-10-0105-1	1			B		CARTON GIFT SPIDER3-3012 A8-5 Rev.B
1	100	40-10-0107-1	1			B		CARTON SHIPPING SPIDER3-3012 A8-5
1	110	40-10-0108	8					PROTECTOR CORNER CARTON SPIDER2-1508/3012
1	120	40-10-0118	1			A		INSERT HNDL-PROTEC 485mm x 260 mm X 3mm SPIDER2-3012
1	130	40-20-0011	1			A		BAG PLASTIC 10 x 16 2 mil
1	140	40-20-2828	1					BAG PLASTIC 28" x 28" 4-MIL
1	150	40-25-0024	1			B		STICKER ART SEAL EULA
1	155	40-25-0038	1			C		STICKER SPEAKER-GRILL PROMO
1	170	40-25-0101	1					LABEL BAR CODE S/N 2-PNL LTX 16 1125502 MATTE WHITE
1	180	59-00-0022-5	1			A		ASSY UNIT COMPLETE SPIDER3 3012 A8-5 US 120V
2	1	11-20-0006	1					1 SPEAKER 12" 4 OHM 50W CH-CONE
3	1	40-25-0057	1			A		LABEL SPEAKER 12-IN 4-OHM CELESTION G12E-50 (11-20-0006)
2	2	21-34-0055	1		H4 (MAIN PCBA TO SPEAKER)	B		CBL ASSY 2 PIN 8.0" LG
2	3	21-34-1015	1					CBL FSTN .187-RCPT/.250-F FLAG 1-COND 161.34MM STRND 18AWG BK
2	4	24-24-0607	1					SWITCH POWER ROCKER 6A/250V 10 A/120V w/O OFF CAP PRINT
2	5	30-00-0033	7					SCREW 10-24 x7/8 TRUSS HD PHH BLK
2	6	30-00-0043	2			A		SCREW 6-32 X 5/16 LG WITH LOCK WASHER PHIL PAN ZINC-PLATED STEEL
2	7	30-00-0375	3					SCREW 6-32 x .375 PPB
2	8	30-00-0402	1					SCREW #4 x 1/2IN SEMS w/EXT. TOOTH WASHER STL/ZNC
2	9	30-00-0676	2					SCREW WOOD NO.6 x 3/4" PHIL OVAL HD BLK
2	10	30-00-1020	4					SCREW 10-24 x 1-1/4 OVAL CTSK PB STL
2	11	30-00-1033	4					SCREW 10-32 x 3/8IN SCH STL BLK OXIDE
2	12	30-03-0112	4					WASHER FINISHING #10 FLANGED STL BLK OXIDE
2	13	30-03-0400	1					WASHER #4 SPLIT LOCKWASHER ZINC
2	14	30-03-0425	1					WASHER #4 0.125" ID x .233" OD .018 HEIGHT ZINC PLATE
2	15	30-06-0440	1					NUT HEX .242 4-40 STL/ZNC
2	16	30-06-0832	4					NUT .335 HEX 8-32 STL ZINC W/ TOOTH WASHER
2	17	30-15-0404	1					SHOULDER BUSHING TO-220
2	18	30-24-0003	3					CABLE TIE 4" CLEAR

2	19	30-27-0191-1	1
3	10	41-00-0094	1
2	20	30-27-0204	1
2	21	30-45-0011	8
2	22	30-51-0259-1	1
3	10	41-00-0087	1
2	23	30-63-1325	2
2	24	30-63-1550	2
2	25	30-63-4003	1
2	26	30-75-0020	1
2	27	30-75-9600	1
2	28	40-25-0015	1
2	29	40-25-0020	1
2	30	40-25-0029	1
2	31	40-25-0147	1
2	32	50-00-0001	1
3	1	21-14-0002	1
3	2	21-34-1116	1
2	33	50-03-0041	1
3	10	30-00-0061	5
3	20	30-00-0812	14
3	30	30-00-0858	5
3	50	30-00-1024	2
3	60	30-00-8112	3
3	70	30-03-0112	3
3	80	30-06-1024	10
3	90	30-28-0002	1
3	100	30-28-0003	1
3	110	30-28-0004	6
3	120	30-36-0005	4
3	130	30-39-0013	1
3	140	30-51-0188-2	1
3	150	30-57-0580	1
3	160	30-57-0581	2
3	170	30-63-0016	4
3	171	40-25-0083	1 EA
2	34	50-04-0038-1	1
3	10	11-30-0013	1
3	20	24-19-0002	1
3	30	50-02-0057	1

A	PANEL FRONT 16.5 x 2.8 x .70 ABS SPIDER3-3012 A8-5
C	ARTWORK SILKSCREEN FRONT PANEL SPIDER3-3012 A8-5
D	LOGO PLATE 9.4 x 1.8 x .26 ABS SILVER A8
D	KNOB POT .77 DIA x .76 HT PLASTIC CHROME PLATED
B	CHASSIS 16.5 x 5.9 x 3.3" ALUMINUM SPIDER3-3012 A8-5
D	ARTWORK SILKSCREEN CHASSIS REAR SPIDER3-3012 A8-5
	FOAM W/ADH. 13.25" x 0.25" x 0.06" VOLARAPOLELEFIN
	FOAM W/ADH. 15.50" x 0.25" x 0.06" VOLARAPOLELEFIN
	PAD THERMAL TO-220 TYPE: K6 BERG K6AC-58
D	KEYPAD RUBBER 6.74 x .57 x 0.23 BLACK SPIDER2
	GROMMET RUBBER 7/16-D x 1/16 GRV x 3/4" GRV-DIA BLACK
	LABEL GROUND SYMBOL
A	LABEL INSPECTION QUALITY
A	LABEL ETL SAITEK 2" x 1"
E	LABEL ETL SUGA 2"X 1" INTERTEK
A	ASSY RECEPTACLE-A/C W/GND WIRE SNAP-IN
	JACK IEC w/FUSE MALE 3 PIN PAN EL MOUNT SNAP IN VERT
C	CBL EARTHING w/EYELET 16AWG 5" GREEN w/YELLOW STRIPE
B	ASSY CABINET SPIDER3-3012 A8-5
	SCREW WOOD NO.6 x 1.0 FHP BLAC K OXIDE
	SCREW w/WAX 8 x 3/4 PTB
	SCREW #8 x 5/8IN PHIL-TRUSS BLACK w/WAX
	SCREW 10-24 x 1IN OVAL CTSK PPB STL WAXED
	SCREW WOOD #8 x 1 1/2" OVAL PH H STL BLK OXIDE
	WASHER FINISHING #10 FLANGED STL BLK OXIDE
	NUT-T 10-24 X 5/16 STEEL
	CORNER LEFT HI-DENSITY POLYETHYLENE TEXTURED BLACK
	CORNER RIGHT HI-DENSITY POLYETHYLENE TEXTURED BLACK
	CORNER BACK HI-DENSITY POLYETHYLENE TEXTURED BLACK
A	COVER VINYL TEXTURED BLACK SEMI GLOSS
	GRILL CLOTH BLACK SPIDER3
A	BRACE BAFFLBOARD 16.55 x .90 x .69 EGS
A	HANDLE STRAP HEAVY DUTY BLACK
A	ENDCAPS BLACK TEXTURED FINISH
	FOAM w/ADHESIVE 8.0 x 1/4 x 1/16 VOLARAPOLELEFIN
4	STICKER CARB WOOD CABINET
	ASSY E/M CHASSIS SPIDER3-3012 A8-5 100V/120V
A	XFMR 100/120VAC 16.5VAC x 2 / 7.2VAC SPIDER2-3012
	FUSE 1A 250V 5MM x 20mm FRNT
	PCBA PANELIZED MAIN/SW/PA SPIDER3-3012 A8-5

4	10	50-02-0310	1		PCBA MAIN SPIDER3-3012 A8-5
5	5	01-16-0102	2	R65-R66	RES CARBON FILM 1K 1/2W 5% TH
5	20	01-24-0000	2	R3,R67	RES OR 1% 0805
5	30	01-24-1000	3	R54,R61,R64	RES 100R 1% 0805
5	40	01-24-1001	2	R2,R8	RES 1.00K 1% 0805
5	50	01-24-1002	5	R38-R39,R53,R55-R56	RES 10.0K 1% 0805
5	60	01-24-1003	2	R57,R68	RES 100K 1% 0805
5	70	01-24-1004	3	R1,R58,R62	RES 1.00M 1% 0805
5	80	01-24-10R0	1	R34	RES 10.0R 1% 0805
5	90	01-24-1332	4	R45,R47-R49	RES 13.3K 1% 0805
5	100	01-24-1502	1	R7	RES 15.0K 1% 0805
5	110	01-24-1620	1	R63	RES 162R 1% 0805
5	120	1/24/1912	2	R22-R23	RES 19.1K 1% 0805
5	130	1/24/2002	2	R20-R21	RES 20.0K 1% 0805
5	140	01-24-22R1	2	R9-R10	RES 22.1R 1% 0805
5	150	1/24/4750	1	R50	RES 475R 1% 0805
5	160	1/24/4751	7	R31-R33,R36-R37,R40,R60	RES 4.75K 1% 0805
5	170	1/24/4752	1	R27	RES 47.5K 1% 0805
5	180	1/24/5492	1	R44	RES 54.9K 1% 0805
5	190	01-24-5R11	2	R25-R26	RES 5.11R 1% 0805
5	200	01-25-0000	2	JP1,JP4	RES OR 1% 0603
5	210	01-48-0001	8	R11,R16-R17,R24,R30,R35,R42,R59	POT MONO 10KB LINEAR 9MM/20MM D-SHFT HOR TH
5	220	03-10-0106	4	C4-C5,C10,C12	CAP ELEC 10uF 10V 20% RADIAL 5/11/2
5	230	03-10-0338	1	C28	CAP ELEC 3300uF 6.3V 20% RADIAL 10/20/5
5	235	03-10-1107	1	C82	CAP ELEC 100uF 6.3V 20% RADIAL 5/11/5
5	240	3/10/6108	2	C8,C37	CAP ELEC 1000uF 6.3V 20% RADIAL 8/11.5/5
5	250	03-12-0107	2	C30,C34	CAP ELEC 100uF 16V 20% RADIAL 6.3/11/5
5	260	03-12-0476	1	C18	CAP ELEC 47uF 16V 20% RADIAL 6.3/11.2/5
5	270	03-12-1338	1	C38	CAP ELEC 3300uF 16V 20% RADIAL 12.5/25/5
5	280	03-14-0228	2	C35-C36	CAP ELEC 2200uF 25V 20% RADIAL 12.5/25/5
5	290	03-18-0105	4	C6-C7,C14-C15	CAP ELEC 1uF 50V 20% RADIAL 5/11/5
5	300	03-18-0106	2	C31-C32	CAP ELEC 10uF 50V 20% RADIAL 5/11/5
5	310	03-50-0220	1	C78	CAP NPO 22pF 50V 5% 0805
5	320	03-50-0270	1	C23	CAP NPO 27pF 50V 5% 0805
5	330	03-50-0470	1	C79	CAP NPO 47pF 50V 5% 0805
5	340	03-52-0102	15	C39-C41,C44-C48,C50-C51,C73-C77	CAP X7R 1nF 50V 10% 0805
5	350	03-52-0104	18	C9,C11,C13,C42-C43,C49,C53,C55-C60,C62-C65,C80	CAP X7R 0.1uF 50V 10% 0805
5	360	03-52-0332	1	C16	CAP X7R 3.3nF 50V 10% 0805
5	370	03-52-0470	1	C72	CAP X7R 47pF 50V 10% 0805

5	380	03-52-0473	16	C2-C3,C17,C19,C25,C27,C33,C52,C54,C61,C66-C71	CAP X7R 47nF 50V 10% 0805
5	390	6/4/4002	8	D16-D17,D19-D24	DIODE SMALL-SIGNAL 100V 30A DO-41 AXIAL TH 1N4002
5	400	06-23-0054	1	D10	DIODE SCHOTTKY DUAL 30V 200mA 5nS SOT-23 SM
5	410	6/28/8410	2	D13-D14	DIODE ZENER 10V 5% 350mW SOT-2 3 SM
5	420	06-34-0016	1	D15	DIODE SWITCHING 75V 200mA 6nS SOT-23 SM
5	430	06-34-0031	5	D2,D18,D25-D27	DIODE GEN PUR DUAL 120V 600mA 50nS SOT-23 SM
5	440	9/10/4401	1	Q2	TRANS NPN SMALL SIGNAL SOT-23 SM
5	450	9/10/4403	1	Q1	TRANS PNP SMALL SIGNAL SOT-23 SM
5	455	11-00-1201	1	Y1	CRYSTAL 12MHz SHORT CAN HC49 T H
5	460	11/10/2012	12	L1-L12	FERRITE BEAD 600R @ 100MHz 300 mA 0805 SM
5	470	12-00-0317	1	U11	A IC VREG ADJ 1.2V-37V 1.5 AMP TO-220 LM317 TH
5	480	12-54-0072	2	U1,U9	IC OP AMP DUAL TL072 SM
5	490	12-58-0339	1	U10	IC COMPARATOR QUAD LM339D SM
5	500	12-64-4552	1	U2	IC CONVERTER 3V 24 BIT 96KHz AUDIO CODEC AK4552 SM
5	510	15-62-0014	1	U6	IC 74HC14 HEX SCHMITT TRIGGER INVERTERS SO-14 SM
5	520	15-62-1009	1	U12	IC 74HCU04 HI SPEED CMOS LOGIC HEX INVERTER TSSOP-14 SM
5	530	15-72-0001	1	U7	IC SRAM 256K x 8 BIT TSOP32 SM
5	540	15-86-0364	1	U5	IC DSP 24 BIT TQFP-100 SM
5	550	21-00-6616	2	J1,J3	B JACK 1/4" TRS PCB MOUNT 6 PIN HORIZONTAL TH
5	560	21-12-0035	1	J2	JACK 3.5MM STEREO 5 PIN CRIMPE D LEADS NON-THREADED
5	570	21-16-0045	1	J4	JACK RJ-45 MOD 8/8 RT/A FEMALE PCB 50AU
5	580	21-20-0205	1	H3	HDR SIL PCB-MT 5 PIN x 2MM MAL E SHRD VERT MT TH
5	590	21-20-1564	1	H4	HDR SIL PCB-MT 4 PIN x .156 MA LE VERT MNT FRIC LOCK
5	600	21-20-1565	1	H5	HDR SIL PCB-MT 5 PIN x .156 MA LE VERT MNT FRIC LOCK
5	610	21-30-0014	1	JP2	A CBL SIL 7 PIN 22AWG 2.54MM x 7 6MM S/T
5	620	21-30-0029	1	H1	A CBL RIBBON DIL 14 PIN .100 PIT CH 2.0" STAKED TO FEMALE
5	630	30-15-0007	1	Y1	INSULATOR XTAL 4.9MM C-C 11.8 x 5.6MM MYLAR
5	640	30-18-3030	3	GF1-GF3	CLIP GROUND PCB .30 x .30 x .07
5	650	30-51-0146	1	SH1	A SHIELD PCB MT FOR 1/4 JACK 1.00 Hx1.25Wx.013THK BERYL COP
5	660	35-00-0310	1		C PCB MAIN SPIDER3-1508/3012 A8-2/A8-5 REV.C
5	670	45-01-0026	1	U3	V1.00 IC PROGRAMMED MCU v1.00 SPIDER3 A8-5/7
6	10	15-84-0936	1		IC MCU 16KB FLASH P89LPC936 TS SOP-28 SM
5	680	45-02-0026	1	U4	V1.00 IC PROGRAMMED FLASH v1.00 SPIDER3-3012 A8-5
6	10	15-78-0005	1		A IC FLASH 512Kb SPI SERIAL SOIC -8 SM
4	20	50-02-0310-1	1		PCBA SWITCH/LED SPIDER3 1508/3012 A8-2/A8-5
5	10	01-24-1300	5	R6,R13,R15,R19,R29	RES 130R 1% 0805
5	20	1/24/4751	5	R5,R12,R14,R18,R28	RES 4.75K 1% 0805
5	30	06-34-0016	5	D3,D5-D6,D9,D11	DIODE SWITCHING 75V 200mA 6nS SOT-23 SM
5	40	18-22-0003	5	D1,D4,D7-D8,D12	LED YELLOW SUPER BRIGHT 2MM x 1.25MM SM

5	50	21-21-0014	1	H6		HDR DIL PCB-MT 14 PIN 2 x 7 x .100 MALE SHRD VERT MNT TH
5	60	35-00-0310-1	1		C	PCB SWITCH/LED SPIDER3 1508/3012 A8-2/A8-5 REV.C
4	30	50-02-0310-2	1			PCBA POWER AMP SPIDER3-3012 A8-5
5	10	01-22-0R22	1	R51		RES METAL OXIDE 0.22R 2W 5% TH
5	20	01-22-02R2	1	R52		RES METAL OXIDE 2.2R 2W 5% TH
5	30	1/24/3241	1	R41		RES 3.24K 1% 0805
5	40	1/24/3921	1	R43		RES 3.92K 1% 0805
5	50	1/24/7502	1	R46		RES 75.0K 1% 0805
5	60	03-14-0107	2	C20,C29		CAP ELEC 100uF 25V 20% RADIAL 6.3/11.2/5
5	70	03-18-0106	1	C21		CAP ELEC 10uF 50V 20% RADIAL 5/11/5
5	80	03-52-0104	3	C22,C24,C26		CAP X7R 0.1uF 50V 10% 0805
5	90	12/30/2050	1	U8		IC POWER AMP 32W TDA2050 TO-22 0/5 TH
5	100	35-00-0310-2	1		C	PCB POWER AMP SPIDER3 1508/3012 A8-2/A8-5 REV.C

BOM Report 99-020-1315 - A8-7 SPIDER3 HD75 US 120V

Level	Item	Part Number	Qty	UOM	Refdes	Find	Rev	Description
1	10	21-37-1160	1					CBL PWR UL/CSA SJT 8.2FT BLK E L-302 w/GND EL70
1	20	40-00-0106	1					MANUAL USER STEELHEAD SPIDER3- 1508/3012/HD75 A8-2/A8-5/A8-7
1	25	40-00-0109	1			A		GUIDE POP-TOPPER SPIDER3-1508/ 3012/HD75 A8-2/ A8-5/A8-7
1	40	40-00-1000	1			H		CARD WARRANTY LINE 6
1	50	40-01-0016	1			C		CARD LICENSE-AGREEMNT END-USER ALL-PRODUCTS
1	60	40-03-0031	1			B		CARD REGISTRATION UK
1	70	40-03-2000	1			F		CARD REGISTRATION US
1	80	40-03-2000-1	1			A		CARD REGISTRATION EUROPE
1	90	40-10-0059	8					FOAM CORNER PE-LAMINATE 1.75" GRAY 5"-CUBE
1	95	40-10-0136-1	1			B		CARTON GIFT SPIDER3-HD75 A8-7 Rev.B
1	105	40-10-0165	1			A		CARTON SHIPPING SPIDER3-HD75 A8-6
1	115	40-20-0010-3	1					POLYBAG 10PE 1090MM x 700MM
1	120	40-20-0011	1			A		BAG PLASTIC 10 x 16 2 mil
1	130	40-25-0024	1			B		STICKER ART SEAL EULA
1	135	40-25-0062	1			A		STICKER SPEAKER-GRILL PROMO S1-1 SPIDER2-HD75
1	150	40-25-0100	1					LABEL BAR CODE SERIAL NUMBER 4-PANEL LABEL MATTE WHITE
1	160	59-00-0023-5	1					ASSY UNIT COMPLETE SPIDER3 HD75 A8-7 US 120V
2	3	06-24-0461	2					DIODE ULTRAFAST RECOVERY 2A 200V TH DO-15
2	5	30-00-0048	4			A		SCREW 10-32 x 1-IN OVAL CTSK PB STL
2	17	30-00-0676	2					SCREW WOOD NO.6 x 3/4" PHIL OVAL HD BLK
2	40	30-03-0112	4					WASHER FINISHING #10 FLANGED STL BLK OXIDE
2	55	30-27-0204	1			D		LOGO PLATE 9.4 x 1.8 x .26 ABS SILVER A8
2	70	40-25-0020	1			A		LABEL INSPECTION QUALITY
2	75	40-25-0029	1			A		LABEL ETL SAITEK 2" x 1"
2	80	40-25-0030	1			A		LABEL ETL KWANASIA 2"x 1"
2	100	50-03-0042	1			B		ASSY CABINET SPIDER3-HD150 / HD75 A8-6, A8-7
3	10	30-00-0812	14					SCREW w/WAX 8 x 3/4 PTB
3	20	30-00-1024	2					SCREW 10-24 x 1IN OVAL CTSK PPB STL WAXED
3	30	30-00-6839	4					SCREW WOOD 10-12 x 7/8" PPZ
3	40	30-00-8112	5					SCREW WOOD #8 x 1 1/2" OVAL PH H STL BLK OXIDE
3	50	30-03-0112	5					WASHER FINISHING #10 FLANGED STL BLK OXIDE
3	60	30-06-1024	2					NUT-T 10-24 X 5/16 STEEL
3	70	30-28-0002	1					CORNER LEFT HI-DENSITY POLYETHYLENE TEXTURED BLACK
3	80	30-28-0003	1					CORNER RIGHT HI-DENSITY POLYETHYLENE TEXTURED BLACK
3	90	30-28-0004	6					CORNER BACK HI-DENSITY POLYETHYLENE TEXTURED BLACK
3	100	30-36-0005	5			A		COVER VINYL TEXTURED BLACK SEMI GLOSS
3	110	30-39-0013	1					GRILL CLOTH BLACK SPIDER3
3	120	30-57-0580	1			A		HANDLE STRAP HEAVY DUTY BLACK
3	130	30-57-0581	2			A		ENDCAPS BLACK TEXTURED FINISH

3	140	30-75-0008	4		C	RUBBER FOOT 1.50" I.D. X .75"H BLACK
3	141	40-25-0083	1	EA	4	STICKER CARB WOOD CABINET
2	110	50-04-0039-1	1			ASSY E/M CHASSIS SPIDER3-HD75 A8-7 100V/120V
3	10	11-30-0025	1		A	XFMR 100/120VAC 50/60Hz 180MM 27.4VAC x 2 / 7.2VAC 3-CONN
3	30	21-34-0008-1	1	H4 (Main PCBA) to H7 (Speaker Out PCBA)		CBL SIL 4 PIN .156" PITCH 6.0"
3	40	21-34-0021-3	1	H7 (Main PCBA) to H1 (Power Amp PCBA)	C	CBL SIL 6 PIN .156" PITCH 10."
3	45	21-34-1015	1			CBL FSTN .187-RCPT/.250-F FLAG 1-COND 161.34MM STRND 18AWG BK
3	60	24-19-4025	1			FUSE 4A 125V 5MM x 20MM TIME L AG
3	75	24-24-0607	1			SWITCH POWER ROCKER 6A/250V 10 A/120V w/O OFF CAP PRINT
3	80	30-00-0018	4			SCREW 6-32 UNC x 0.750" PAN-HD ZINC SELF-TAP F
3	90	30-00-0043	2		A	SCREW 6-32 X 5/16 LG WITH LOCK WASHER PHIL PAN ZINC-PLATED STEEL
3	100	30-00-0375	3			SCREW 6-32 x .375 PPB
3	110	30-00-1033	12			SCREW 10-32 x 3/8IN SCH STL BLK OXIDE
3	120	30-06-0832	4			NUT .335 HEX 8-32 STL ZINC W/ TOOTH WASHER
3	125	30-24-0003	4			CABLE TIE 4" CLEAR
3	130	30-27-0191-2	1		A	PANEL FRONT 16.5 x 2.8 x .70 ABS SPIDER3-HD75 A8-7
4	10	41-00-0096	1		A	ARTWORK SILKSCREEN FRONT PANEL SPIDER3-HD75 A8-7
3	140	30-27-0192-1	1		A	PANEL FRONT EXT LEFT 4.1 x 2.9 ABS SPIDER3-HD75 A8-7
3	150	30-27-0192-2	1		A	PANEL FRONT EXT RIGHT 4.1 x 2.8 ABS SPIDER3-HD75 A8-7
3	160	30-45-0011	8		D	KNOB POT .77 DIA x .76 HT PLASTIC CHROME PLATED
3	170	30-51-0260	1		B	CHASSIS 24.6 x 7.1 x 4.2 STEEL SPIDER3-HD75 A8-7
4	10	41-00-0089	1		C	ARTWORK SILKSCREEN CHASSIS REAR SPIDER3-HD75 A8-7
3	180	30-63-0010	6			FOAM w/ADHSV 26.5x 1/4x 1/16" VOLARAPOLELEFIN
3	190	30-75-0020	1		D	KEYPAD RUBBER 6.74 x .57 x 0.23 BLACK SPIDER2
3	195	50-00-0001	1		A	ASSY RECEPTACLE-A/C W/GND WIRE SNAP-IN
4	1	21-14-0002	1			JACK IEC w/FUSE MALE 3 PIN PAN EL MOUNT SNAP IN VERT
4	2	21-34-1116	1		C	CBL EARTHING w/EYELET 16AWG 5" GREEN w/YELLOW STRIPE
3	200	50-02-0062	1			PCBA SPEAKER OUT SPIDER2/ SPIDER3-HD75 A3-1/A8-7
4	10	03-00-0101	2	C20,C25		CAP CER DISC 100pF 50V 5% TH
4	20	03-36-0102	2	C24,C26		CAP ESTR 1nF 100V 5% TH 7.2/2.5/6.5/5
4	30	21-00-6616	2	J5-J6	B	JACK 1/4" TRS PCB MOUNT 6 PIN HORIZONTAL TH
4	40	21-20-1564	1	H7		HDR SIL PCB-MT 4 PIN x .156 MA LE VERT MNT FRIC LOCK
4	50	30-18-3030	2	GF1-GF2		CLIP GROUND PCB .30 x .30 x .07
4	60	35-00-0062	1		A	PCB SPEAKER OUT SPIDER2-HD75 A3-1 REV.A
3	210	50-02-0066	1			PCBA POWER AMP w/HEATSINK SPIDER2/3-HD75 A3-1/A8-7
4	10	30-00-0010	1			SCREW 8-32 UNC x 0.563" SOCKET-HD STEEL
4	20	30-00-0028	1			SCREW 8-32 x 5/16" SHCS
4	30	30-03-0002	2			WASHER #8 .293 x .174x .040 STEEL
4	40	30-06-0007	2			NUT .344 HEX 8-32 STEEL ZINC
4	50	30-51-0059-3	1		F	HEATSINK 4.0" LG ALUMINUM ALLOY BLACK ANODIZE
4	60	30-51-0073	1		B	CLAMP HEATSINK TO-220 1.3 x .45 x .35" CR STEEL 1018
4	70	30-51-0105	1		A	BRACKET SUPPORT .565 x .530 x .690 ELECTRO GALVANIZED STEEL

4	80	30-63-0006	1		A	PAD THERMAL 6MIL 25MM x 30MM w/ADHESIVE 4KVAC VTM-O
4	90	50-02-0061	1			PCBA POWER AMP SPIDER2/ SPIDER3-HD75 A3-1/A8-7
5	10	01-00-0103	1	R14		RES 10K 5% 0805
5	15	01-22-0R22	2	R7-R8		RES METAL OXIDE 0.22R 2W 5% TH
5	30	01-23-02R2	1	R6	A	RES METAL OXIDE 2.2R 3W 5% TH
5	40	01-24-1693	1	R9		RES 169K 1% 0805
5	50	01-60-0203	1	R10		RES NETWORK ISOLATED 20K 16P 8R .3W 2% CER SOP-16 SM
5	60	03-18-0336	1	C16		CAP ELEC 33uF 50V 20% RADIAL 5/11/5
5	70	03-18-1106	1	C12		CAP ELEC 10uF 50V 20% BI-POLAR RADIAL 6.3/11.2/5
5	80	03-22-0476	2	C8,C10		CAP ELEC 47uF 100V 20% RADIAL 10/15/5
5	90	03-24-0564	1	C9	A	CAP MET POLY 0.56uF 100VDC 5% TH 4.5/7.5/7/5
5	100	03-52-0470	1	C13		CAP X7R 47pF 50V 10% 0805
5	110	03-52-0680	1	C11		CAP X7R 68pF 50V 10% 0805
5	120	03-52-1103	2	C14-C15		CAP X7R 10nF 100V 10% 0805
5	130	12/30/7293	1	U2		IC POWER AMP 100W TDA7293 TO- 220/15 TH
5	140	21-20-1566	1	H1		HDR SIL PCB-MT 6 PIN x .156 MA LE VERT MNT FRIC LOCK
5	150	35-00-0061	1		A	PCB POWER AMP SPIDER2-HD75 A3-1 REV.A
3	220	50-02-0311	1		A	PCBA MAIN SPIDER3-HD75 A8-7
4	15	01-21-0202	2	R65-R66		RES METAL OXIDE 2K 1W 5% TH
4	20	01-24-0000	1	R3		RES OR 1% 0805
4	30	01-24-1000	3	R54,R61,R64		RES 100R 1% 0805
4	40	01-24-1001	2	R2,R8		RES 1.00K 1% 0805
4	50	01-24-1002	6	R38-R39,R41,R43,R53,R55		RES 10.0K 1% 0805
4	60	01-24-1003	1	R46		RES 100K 1% 0805
4	70	01-24-1004	2	R1,R56		RES 1.00M 1% 0805
4	80	01-24-10R0	1	R34		RES 10.0R 1% 0805
4	90	01-24-1332	4	R45,R47-R49		RES 13.3K 1% 0805
4	100	01-24-1502	1	R7		RES 15.0K 1% 0805
4	110	01-24-1620	1	R63		RES 162R 1% 0805
4	120	1/24/1912	2	R22-R23		RES 19.1K 1% 0805
4	130	1/24/2002	2	R20-R21		RES 20.0K 1% 0805
4	140	01-24-22R1	2	R9-R10		RES 22.1R 1% 0805
4	160	1/24/4750	1	R50		RES 475R 1% 0805
4	170	1/24/4751	7	R31-R33,R36-R37,R40,R60		RES 4.75K 1% 0805
4	180	1/24/4752	1	R27		RES 47.5K 1% 0805
4	190	1/24/5492	1	R44		RES 54.9K 1% 0805
4	200	01-24-5R11	2	R25-R26		RES 5.11R 1% 0805
4	210	01-48-0001	8	R11,R16-R17,R24,R30,R35,R42,R59		POT MONO 10KB LINEAR 9MM/20MM D-SHFT HOR TH
4	220	03-10-0106	4	C4-C5,C10,C12		CAP ELEC 10uF 10V 20% RADIAL 5/11/2
4	230	03-10-0338	1	C28		CAP ELEC 3300uF 6.3V 20% RADIAL 10/20/5
4	235	03-10-1107	1	C29		CAP ELEC 100uF 6.3V 20% RADIAL 5/11/5
4	240	3/10/6108	2	C8,C37		CAP ELEC 1000uF 6.3V 20% RADIAL 8/11.5/5

4	250 03-12-0107	2	C30,C34		CAP ELEC 100uF 16V 20% RADIAL 6.3/11/5
4	260 03-12-0476	1	C18		CAP ELEC 47uF 16V 20% RADIAL 6.3/11.2/5
4	270 03-12-1338	1	C38		CAP ELEC 3300uF 16V 20% RADIAL 12.5/25/5
4	280 03-18-0105	4	C6-C7,C14-C15		CAP ELEC 1uF 50V 20% RADIAL 5/11/5
4	290 03-18-0106	3	C20,C31-C32		CAP ELEC 10uF 50V 20% RADIAL 5/11/5
4	300 03-18-0228	2	C35-C36		CAP ELEC 2200uF 50V 20% RADIAL 16/31.5/7.5
4	310 03-50-0220	1	C22		CAP NPO 22pF 50V 5% 0805
4	320 03-50-0270	1	C23		CAP NPO 27pF 50V 5% 0805
4	330 03-50-0470	1	C24		CAP NPO 47pF 50V 5% 0805
4	340 03-52-0102	15	C39-C41,C44-C48,C50-C51,C73-C77 C9,C11,C13,C21,C42-C43,C49,C53,C55-		CAP X7R 1nF 50V 10% 0805
4	345 03-52-0104	18	C60,C62-C65		CAP X7R 0.1uF 50V 10% 0805
4	350 03-52-0332	1	C16		CAP X7R 3.3nF 50V 10% 0805
4	360 03-52-0470	1	C72 C2- C3,C17,C19,C25,C27,C52,C54,C61,C66-		CAP X7R 47pF 50V 10% 0805
4	370 03-52-0473	15	C71		CAP X7R 47nF 50V 10% 0805
4	380 6/4/4002	4	D21-D24		DIODE SMALL-SIGNAL 100V 30A DO-41 AXIAL TH 1N4002
4	390 06-16-0008	1	D28		DIODE BRIDGE RECTIFIER 600V 8A 4 PIN SIL TH
4	400 06-23-0054	2	D10,D15		DIODE SCHOTTKY DUAL 30V 200mA 5nS SOT-23 SM
4	410 6/28/8410	2	D13-D14		DIODE ZENER 10V 5% 350mW SOT-2 3 SM
4	420 06-34-0031	5	D2,D18,D25-D27		DIODE GEN PUR DUAL 120V 600mA 50nS SOT-23 SM
4	430 09-00-5401	1	Q4		TRANS PNP SMALL SIGNAL 2N5401 TH
4	440 09-00-5551	1	Q3		TRANS NPN SMALL SIGNAL 2N5551 TH
4	450 11-00-1201	1	Y1		CRYSTAL 12MHz SHORT CAN HC49 T H
4	460 11/10/2012	12	L1-L12		FERRITE BEAD 600R @ 100MHz 300 mA 0805 SM
4	470 12-00-0317	1	U11	A	IC VREG ADJ 1.2V-37V 1.5 AMP TO-220 LM317 TH
4	480 12-54-0072	2	U1,U9		IC OP AMP DUAL TL072 SM
4	490 12-64-4552	1	U2		IC CONVERTER 3V 24 BIT 96KHz AUDIO CODEC AK4552 SM
4	500 15-62-0014	1	U6		IC 74HC14 HEX SCHMITT TRIGGER INVERTERS SO-14 SM
4	510 15-62-1009	1	U8		IC 74HCU04 HI SPEED CMOS LOGIC HEX INVERTER TSSOP-14 SM
4	520 15-72-0001	1	U7		IC SRAM 256K x 8 BIT TSOP32 SM
4	530 15-86-0364	1	U5		IC DSP 24 BIT TQFP-100 SM
4	540 21-00-6616	2	J1,J3	B	JACK 1/4" TRS PCB MOUNT 6 PIN HORIZONTAL TH
4	550 21-12-0035	1	J2		JACK 3.5MM STEREO 5 PIN CRIMPE D LEADS NON-THREADED
4	560 21-16-0045	1	J4		JACK RJ-45 MOD 8/8 RT/A FEMALE PCB 50AU
4	570 21-20-0205	1	H3		HDR SIL PCB-MT 5 PIN x 2MM MAL E SHRD VERT MT TH
4	580 21-20-0206	1	H2		HDR SIL PCB-MT 6 PIN x 2MM MAL E SHRD VERT MT TH
4	590 21-20-1564	1	H4		HDR SIL PCB-MT 4 PIN x .156 MA LE VERT MNT FRIC LOCK
4	600 21-20-1565	1	H5		HDR SIL PCB-MT 5 PIN x .156 MA LE VERT MNT FRIC LOCK
4	610 21-20-1566	1	H7		HDR SIL PCB-MT 6 PIN x .156 MA LE VERT MNT FRIC LOCK
4	620 21-30-0029	1	H1 (Connects to H6 on Switch PCBA)	A	CBL RIBBON DIL 14 PIN .100 PIT CH 2.0" STAKED TO FEMALE

4	630	30-15-0007	1	Y1	INSULATOR XTAL 4.9MM C-C 11.8 x 5.6MM MYLAR
4	640	30-18-3030	3	GF1-GF3	CLIP GROUND PCB .30 x .30 x .07
4	650	30-51-0146	1	SH1	A SHIELD PCB MT FOR 1/4 JACK 1.00 Hx1.25Wx.013THK BERYL COP
4	660	35-00-0311	1		B PCB MAIN SPIDER3-HD75 A8-7 REV.B
4	670	45-01-0026	1	U3	V1.00 IC PROGRAMMED MCU v1.00 SPIDER3 A8-5/7
5	10	15-84-0936	1		IC MCU 16KB FLASH P89LPC936 TS SOP-28 SM
4	680	45-02-0028	1	U4	V1.00 IC PROGRAMMED FLASH v1.00 SPIDER3-HD75 A8-7
5	10	15-78-0005	1		A IC FLASH 512Kb SPI SERIAL SOIC -8 SM
3	230	50-02-0311-1	1		A PCBA SWITCH/LED SPIDER3-HD75 A8-7
4	10	01-24-1300	5	R6,R13,R15,R19,R29	RES 130R 1% 0805
4	20	1/24/4751	5	R5,R12,R14,R18,R28	RES 4.75K 1% 0805
4	30	06-34-0016	5	D3,D5-D6,D9,D11	DIODE SWITCHING 75V 200mA 6nS SOT-23 SM
4	40	18-22-0003	5	D1,D4,D7-D8,D12	LED YELLOW SUPER BRIGHT 2MM x 1.25MM SM
4	50	21-21-0014	1	H6	HDR DIL PCB-MT 14 PIN 2 x 7 x .100 MALE SHRD VERT MNT TH
4	60	35-00-0311-1	1		B PCB SWITCH/LED SPIDER3-HD75 A8-7 REV.B

6

5

4

3

2

1

ECOs INCLUDED ON THIS SCHEMATIC/PCB REVISION		
ECO NO:	DATE:	DESCRIPTION:
0615305	06/02/06	Initial Rev A Release to MFG - JB
0615807	06/02/06	No schematic revision. PCB silkscreen revised for JP1-4
0615605 xxxxxxx	06/06/06 06/13/06	No schematic revision. Change R65-66 to 1K 1/2W 5%
0618606	07/05/06	Rev C: Added C82 across U3 supply.

D

C

B

A

D

C

B

A

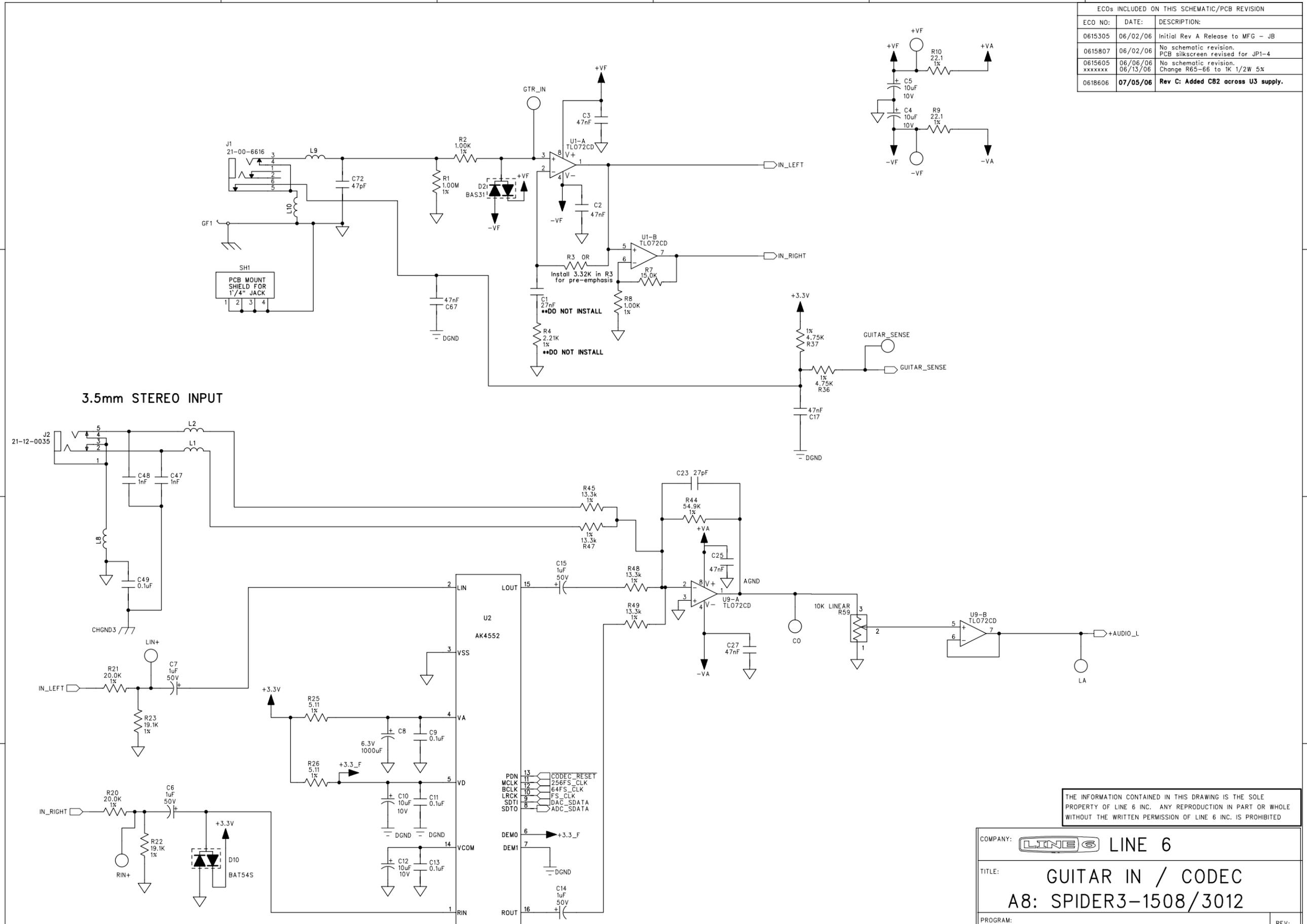

THE INFORMATION CONTAINED IN THIS DRAWING IS THE SOLE PROPERTY OF LINE 6 INC. ANY REPRODUCTION IN PART OR WHOLE WITHOUT THE WRITTEN PERMISSION OF LINE 6 INC. IS PROHIBITED

COMPANY: **LINE 6**

TITLE: **GUITAR IN / CODEC
A8: SPIDER3-1508/3012**

PROGRAM: PADS POWER LOGIC V5.0

REV: **C**

DRAWN: T. BURTON	DATED: 06/28/2006	FILENAME: A8-2 & A8-5 SPIDER III 1508-3012 REV C	REV: C
CHECKED:	DATED:	SCALE: 1:1	SIZE: C
PART NUMBER: 35-00-0310-1		SHEET: 1 OF 4	

6

5

4

3

2

1

DIGITAL SECTION

ECOs INCLUDED ON THIS SCHEMATIC/PCB REVISION		
ECO NO:	DATE:	DESCRIPTION:

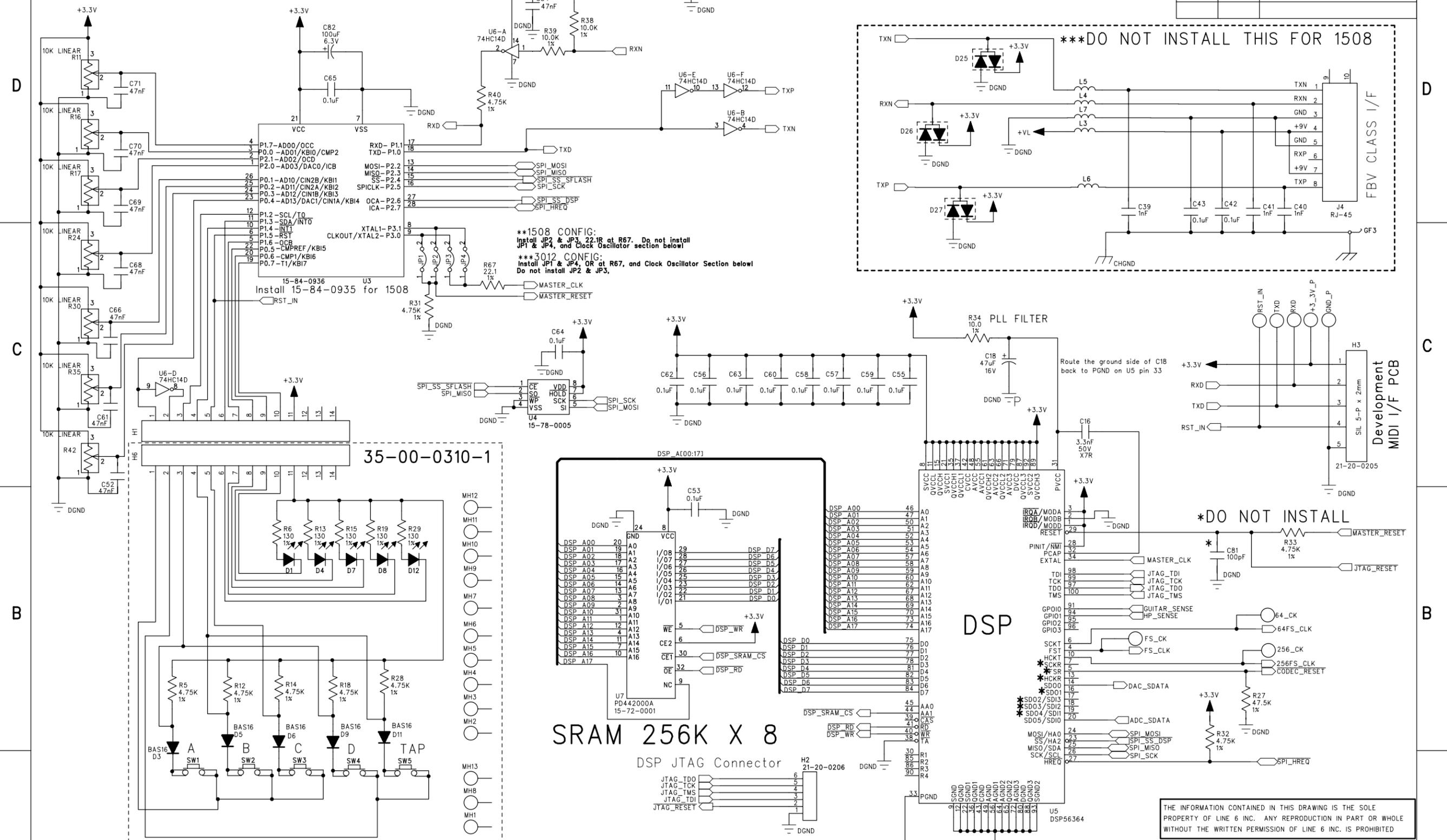

****1508 CONFIG:**
Install JP2 & JP3, 22.1R at R67. Do not install JP1 & JP4, and Clock Oscillator section below

****3012 CONFIG:**
Install JP1 & JP4, OR at R67, and Clock Oscillator Section below
Do not install JP2 & JP3.

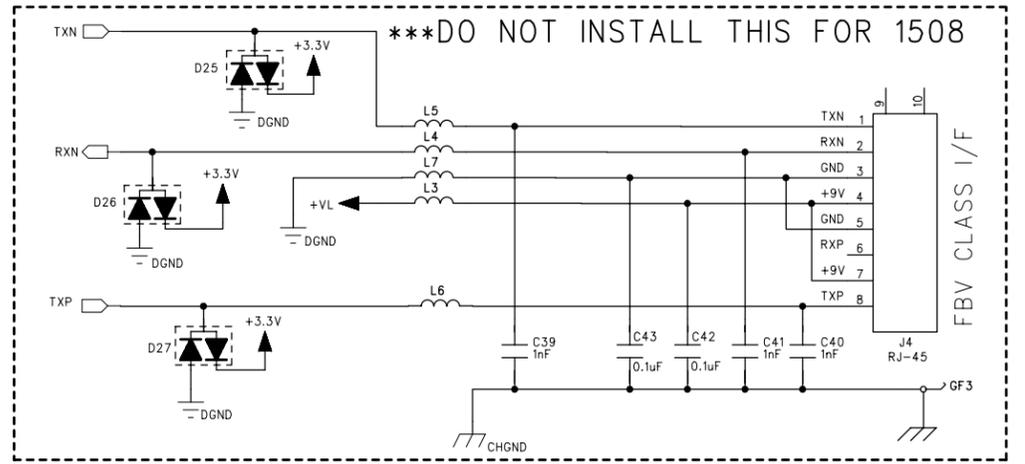

D

D

C

C

B

B

A

A

DSP CLOCKING
When using the Clock Oscillator Section:
DSP CORE CLOCK = 100MHz
256FS_CLK = 10MHz
64FS_CLK = 2.5MHz
FS_CLK = 39.0625KHz

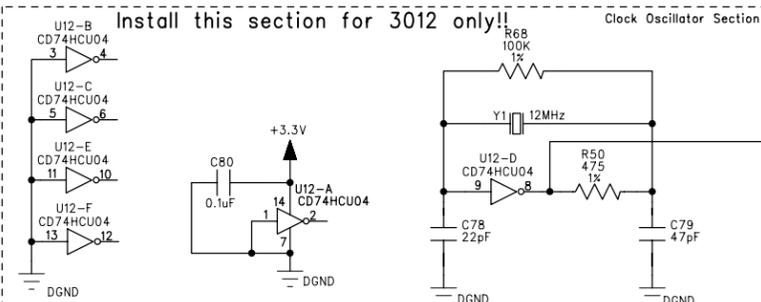

THE INFORMATION CONTAINED IN THIS DRAWING IS THE SOLE PROPERTY OF LINE 6 INC. ANY REPRODUCTION IN PART OR WHOLE WITHOUT THE WRITTEN PERMISSION OF LINE 6 INC. IS PROHIBITED

COMPANY:	LINE 6		
TITLE:	DIGITAL SECTION		
PROGRAM:	PADS POWER LOGIC V5.0		
FILENAME:	A8-2 & A8-5 SPIDER III 1508-3012 REV C		
DRAWN:	T. Burton / D. Molnar	DATED:	06/28/2006
CHECKED:		DATED:	
SCALE:	1:1	SIZE:	C
PART NUMBER:	35-00-0310	35-00-0310-1	35-00-0310-2
SHEET:	2 OF 4		

POWER AMP / HEADPHONE AMP

ECOs INCLUDED ON THIS SCHEMATIC/PCB REVISION		
ECO NO:	DATE:	DESCRIPTION:

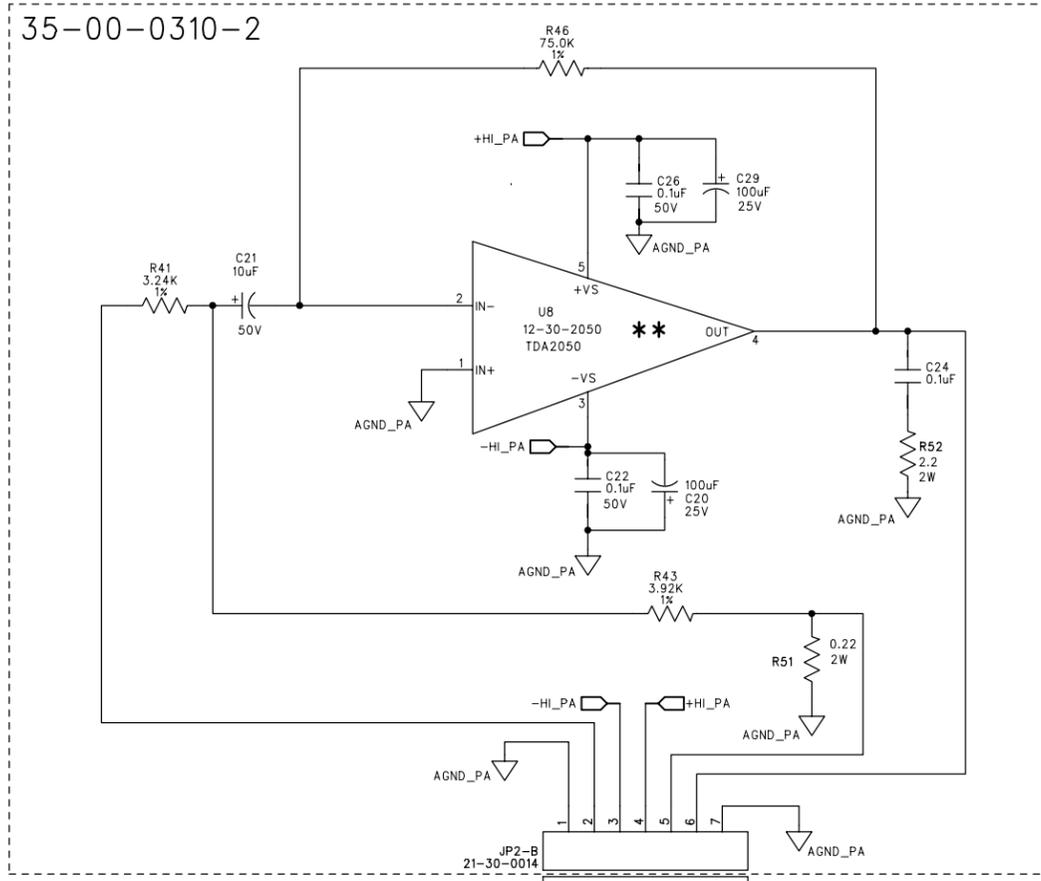

**U8: INSTALL 12-30-2050 FOR 3012
INSTALL 12-30-2030 FOR 1508

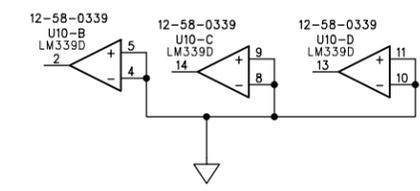
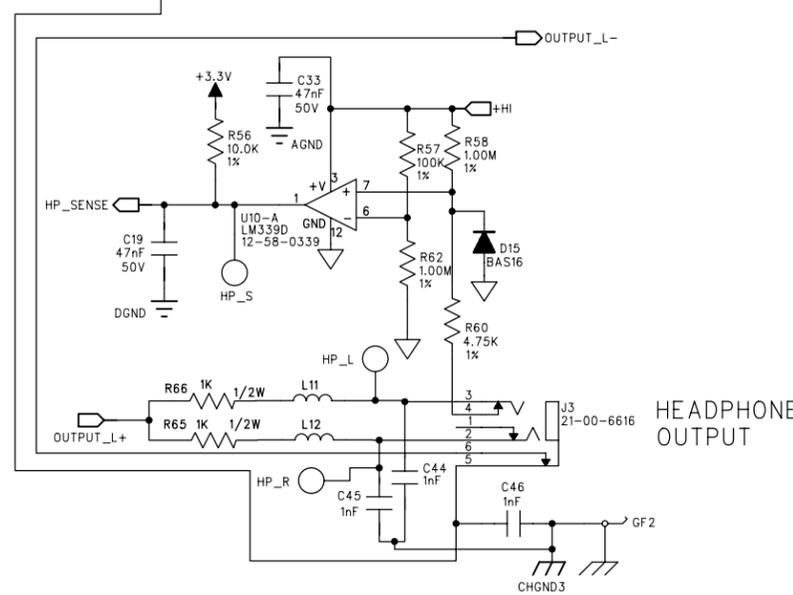
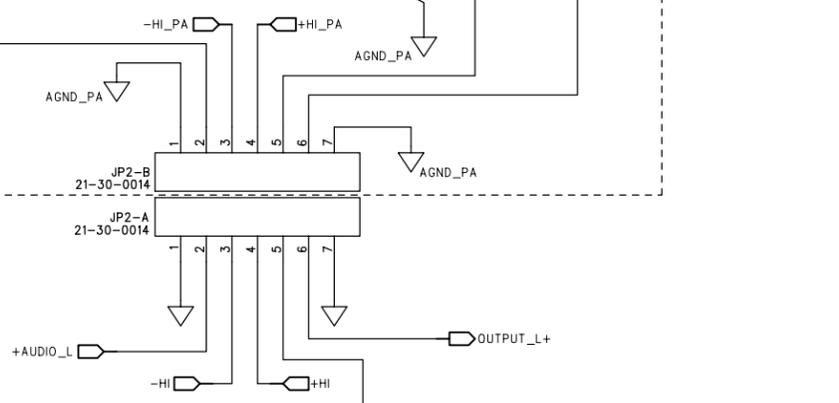
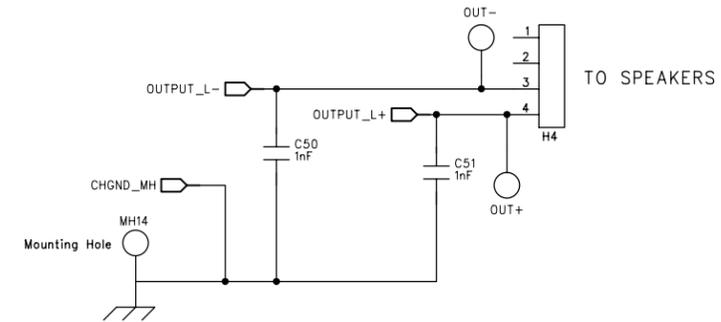

THE INFORMATION CONTAINED IN THIS DRAWING IS THE SOLE PROPERTY OF LINE 6 INC. ANY REPRODUCTION IN PART OR WHOLE WITHOUT THE WRITTEN PERMISSION OF LINE 6 INC. IS PROHIBITED.

COMPANY:	LINE 6
TITLE:	A8: SPIDER3 - 1508/3012 POWER AMP / HEADPHONE AMP
PROGRAM:	PADS POWER LOGIC V5.0
REV:	C
FILENAME:	A8-2 & A8-5 SPIDER III 1508-3012 REV C
SCALE:	1:1
SIZE:	C
PART NUMBER:	35-00-0310-1 35-00-0310-2
SHEET:	3 OF 4

DRAWN:	T. BURTON	DATED:	06/28/2006
CHECKED:		DATED:	

POWER SUPPLY

ECOs INCLUDED ON THIS SCHEMATIC/PCB REVISION		
ECO NO:	DATE:	DESCRIPTION:

DIFFERENT TRANSFORMER
FOR USA & EUROPE

1508:
100/120V = 11-30-0015
220/240V = 11-30-0016

3012:
100/120V = 11-30-0013
220/240V = 11-30-0014

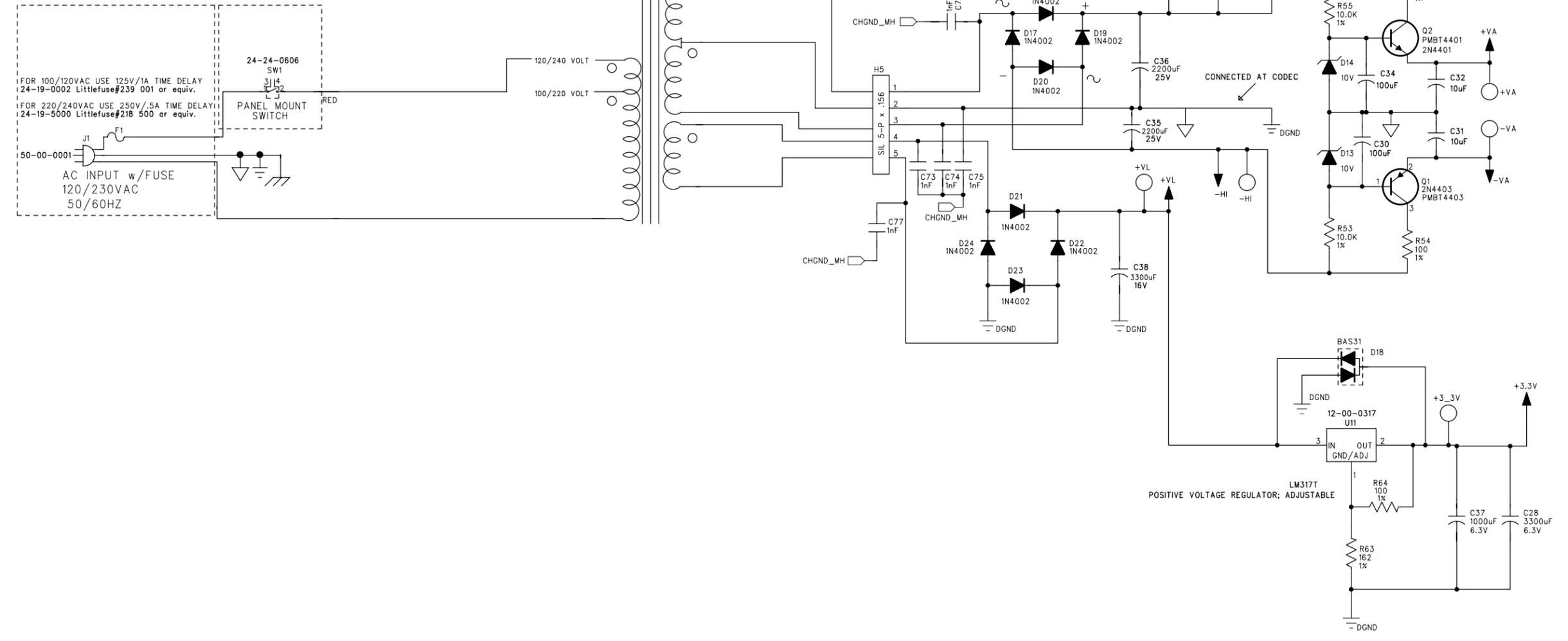

FOR 100/120VAC USE 125V/1A TIME DELAY
24-19-0002 Littlefuse#239 001 or equiv.

FOR 220/240VAC USE 250V/5A TIME DELAY
24-19-5000 Littlefuse#218 500 or equiv.

AC INPUT w/FUSE
120/230VAC
50/60HZ

24-24-0606
SW1
31/4
1/2
PANEL MOUNT
SWITCH

THE INFORMATION CONTAINED IN THIS DRAWING IS THE SOLE
PROPERTY OF LINE 6 INC. ANY REPRODUCTION IN PART OR WHOLE
WITHOUT THE WRITTEN PERMISSION OF LINE 6 INC. IS PROHIBITED

COMPANY: LINE 6	
TITLE: A8: SPIDER 3 - 1508/3012 POWER SUPPLY	
PROGRAM: PADS POWER LOGIC V5.0	REV: C
FILENAME: A8-2 & A8-5 SPIDER III 1508-3012 REV C	
SCALE: 1:1	SIZE: C
PART NUMBER: 35-00-0310	35-00-0310-1 35-00-0310-2
SHEET: 4	OF 4

DRAWN: T. BURTON	DATED: 06/28/2006
CHECKED:	DATED:

6

5

4

3

2

1

ECOs INCLUDED ON THIS SCHEMATIC/PCB REVISION		
ECO NO:	DATE:	DESCRIPTION:
0505302	2.23.05	Released as rev.A to MFG - mh
0510103	4.11.05	Changed R65 & R66 to 1K 1W

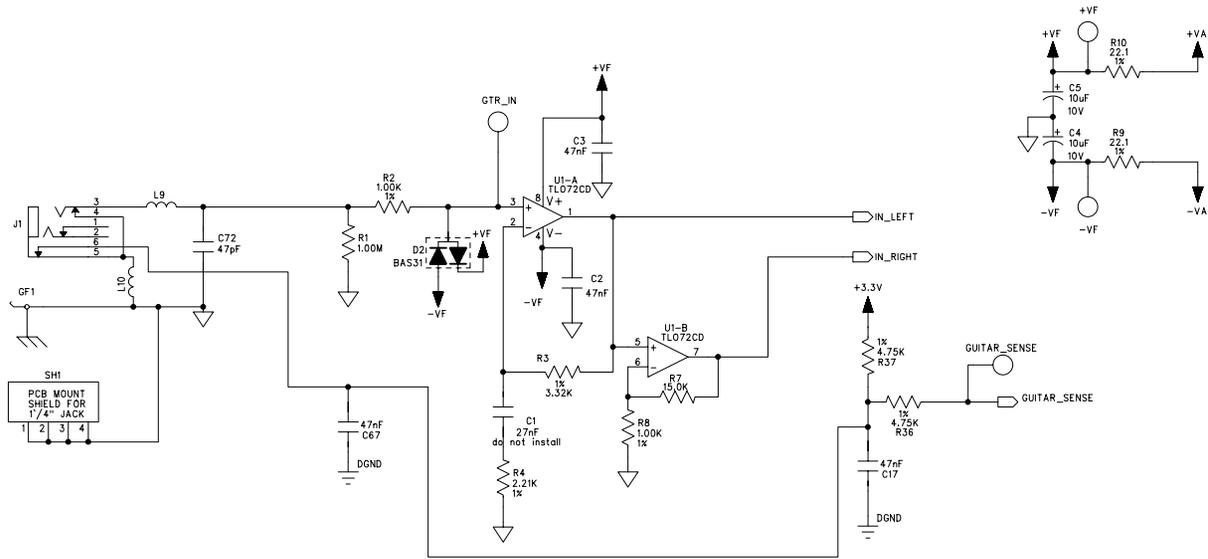

3.5mm STEREO INPUT

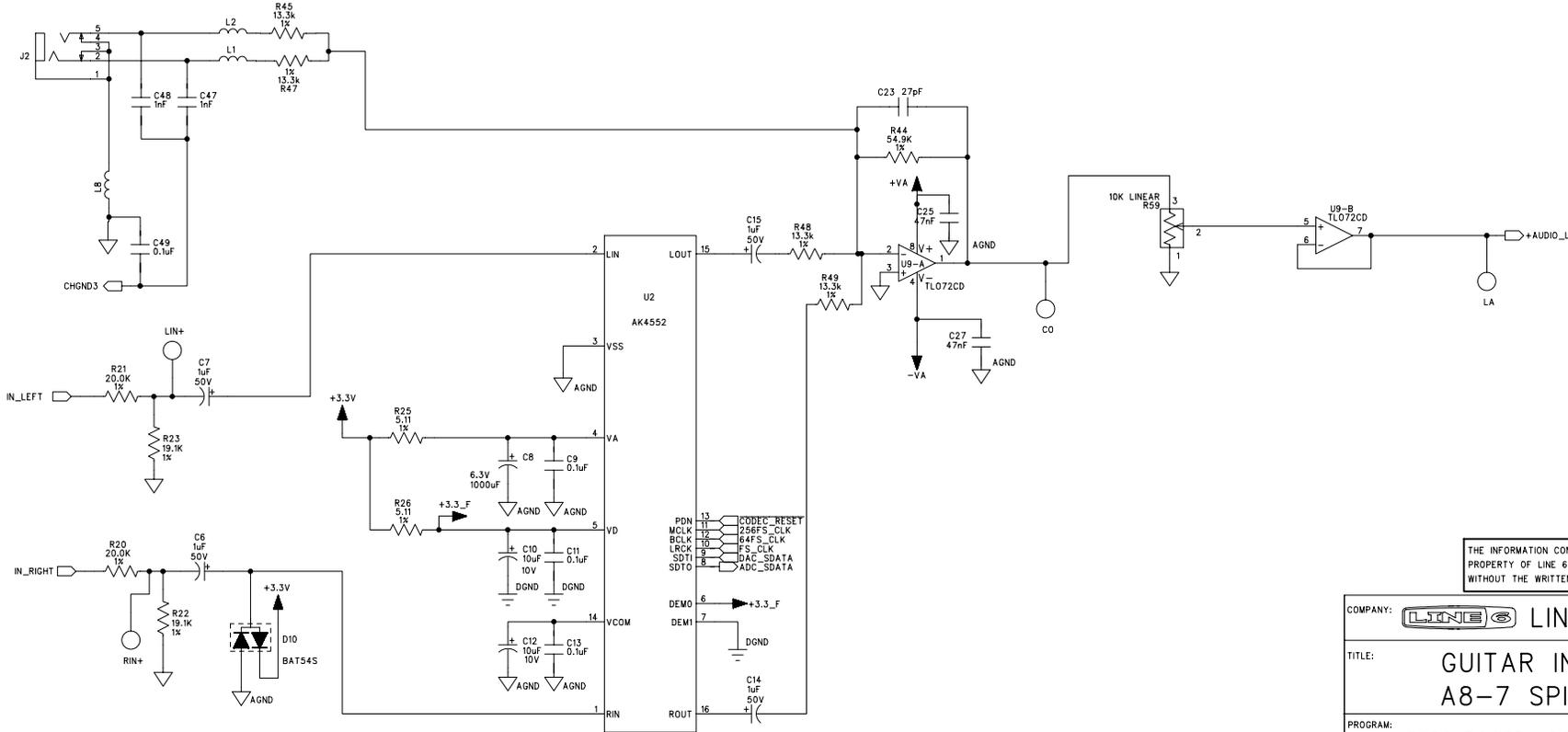

THE INFORMATION CONTAINED IN THIS DRAWING IS THE SOLE PROPERTY OF LINE 6 INC. ANY REPRODUCTION IN PART OR WHOLE WITHOUT THE WRITTEN PERMISSION OF LINE 6 INC. IS PROHIBITED

COMPANY: LINE 6		REV: X0
TITLE: GUITAR IN / CODEC A8-7 SPIDER3 HD75		
PROGRAM: PADS POWER LOGIC V5.0		SHEET: 1 OF 4
FILENAME: A8-7 MAIN_LED_REV X0.sch	SCALE: 1:1	
DATE: 11/10/2005	SIZE: C	

DRAWN: T. BURTON	DATE: 11/10/2005
CHECKED:	DATE:

DIGITAL SECTION

ECOs INCLUDED ON THIS SCHEMATIC/PCB REVISION		
ECO NO:	DATE:	DESCRIPTION:

D
C
B
A

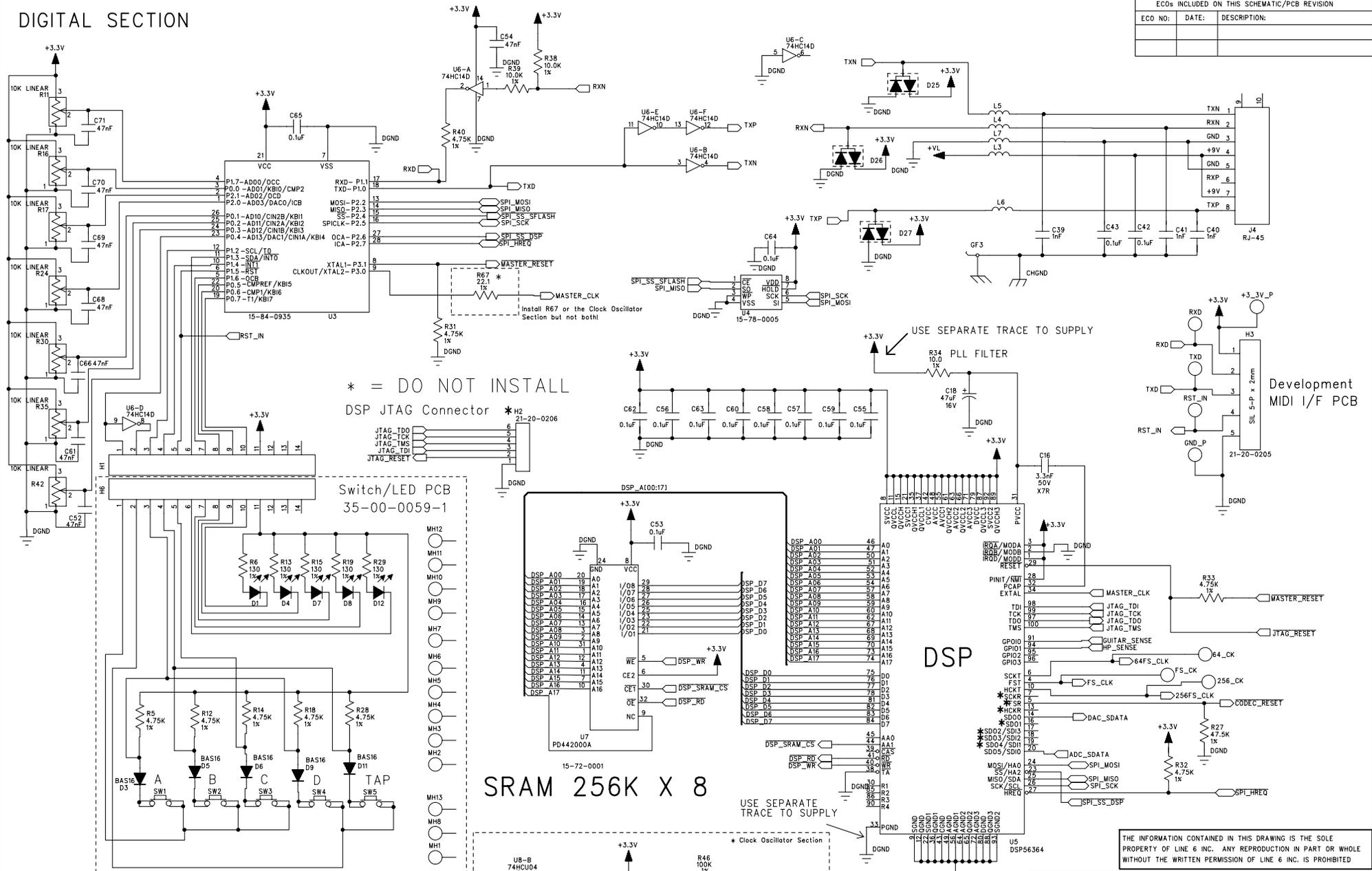

* = DO NOT INSTALL

DSP JTAG Connector *H2 21-20-0206

Switch/LED PCB
35-00-0059-1

SRAM 256K X 8

DSP CORE CLOCK = 99,993,600 Hz (approx 100MHz)
 256FS_CLK = 9,999,360 Hz
 64FS_CLK = 2,499,840 Hz
 FS_CLK = 39,060 Hz

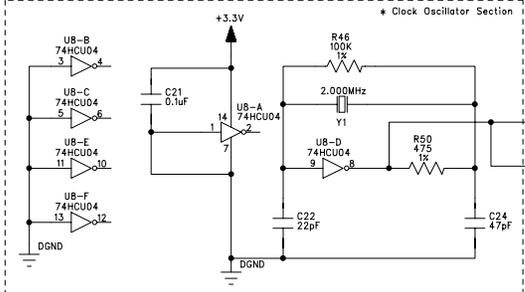

DRAWN: T. BURTON/B.H.	DATED: 11/10/2005
CHECKED:	DATED:

COMPANY: LINE 6	FILENAME: AB-7 MAIN_LED_REV.X0.sch
TITLE: DIGITAL SECTION A8-7 SPIDER3 HD75	SCALE: 1:1 SIZE: C
PROGRAM: PADS POWER LOGIC V5.0	PART NUMBER: 35-00-031135-00-0311-1
REV: X0	SHEET: 2 OF 4

THE INFORMATION CONTAINED IN THIS DRAWING IS THE SOLE PROPERTY OF LINE 6 INC. ANY REPRODUCTION IN PART OR WHOLE WITHOUT THE WRITTEN PERMISSION OF LINE 6 INC. IS PROHIBITED

POWER AMP / HEADPHONE AMP

ECO#s INCLUDED ON THIS SCHEMATIC/PCB REVISION		
ECO NO:	DATE:	DESCRIPTION:

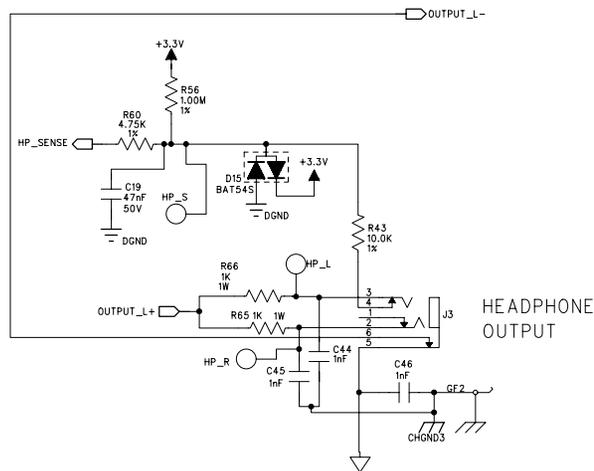
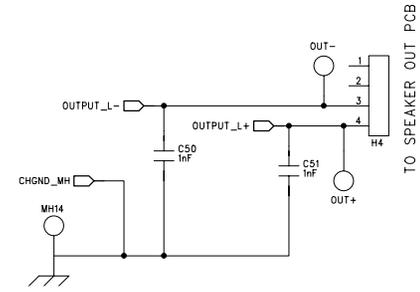
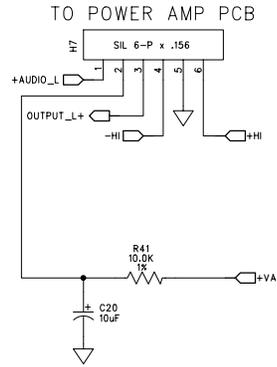

THE INFORMATION CONTAINED IN THIS DRAWING IS THE SOLE PROPERTY OF LINE 6 INC. ANY REPRODUCTION IN PART OR WHOLE WITHOUT THE WRITTEN PERMISSION OF LINE 6 INC. IS PROHIBITED

COMPANY:	LINE 6	
TITLE:	A8-7 SPIDER3 HD75 POWER AMP / HEADPHONE AMP	
PROGRAM:	PADS POWER LOGIC V5.0	REV: X0
DRAWN:	T. BURTON	DATED: 11/10/2005
CHECKED:	Date	
SCALE:	1:1	SIZE: C
PART NUMBER:	35-00-031135-00-0311-1	SHEET: 3 OF 4

DRAWN:	T. BURTON	DATED:	11/10/2005
CHECKED:	Date	DATED:	

POWER SUPPLY

ECOs INCLUDED ON THIS SCHEMATIC/PCB REVISION		
ECO NO:	DATE:	DESCRIPTION:

DIFFERENT TRANSFORMER
FOR USA & EUROPE

100/120V = 11-30-0025
220/240V = 11-30-0026

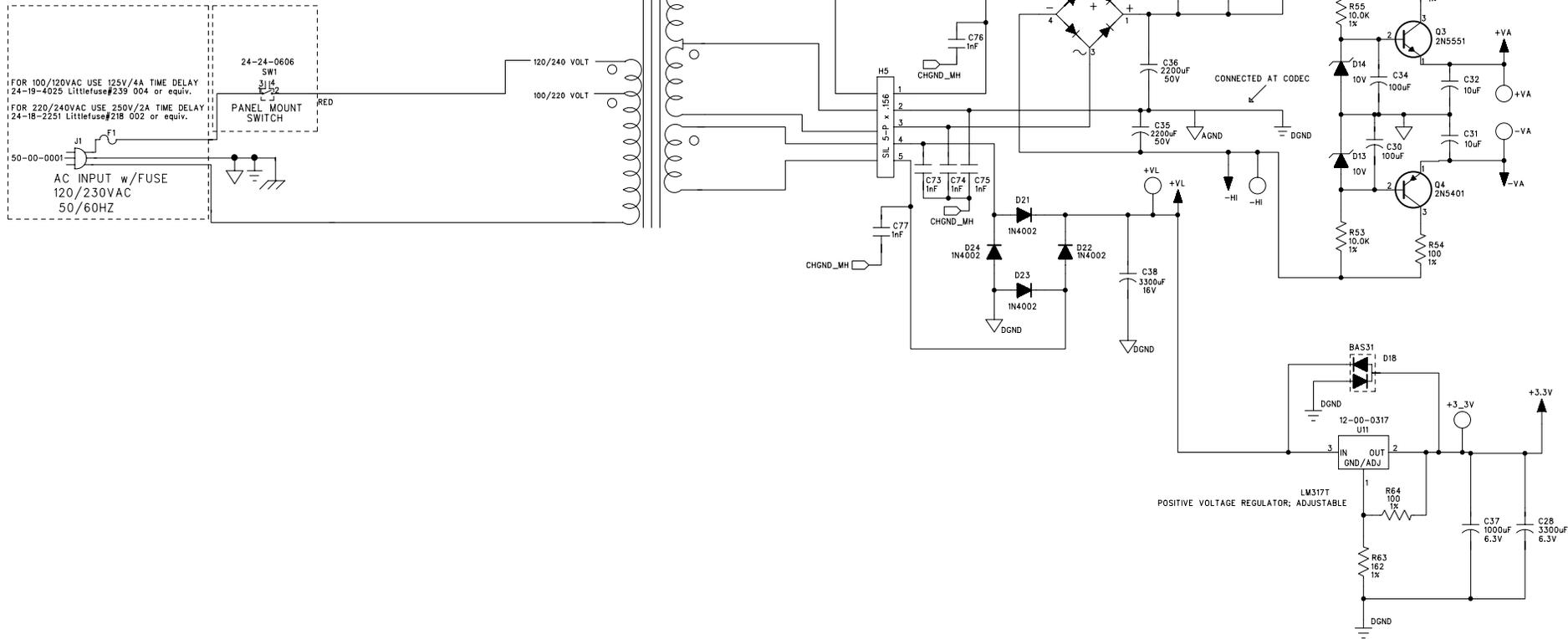

FOR 100/120VAC USE 125V/4A TIME DELAY
24-19-4025 Littlefuse#239 004 or equiv.

FOR 220/240VAC USE 250V/2A TIME DELAY
24-18-2251 Littlefuse#218 002 or equiv.

AC INPUT w/FUSE
120/230VAC
50/60HZ

24-24-0606
SW1
PANEL MOUNT
SWITCH

THE INFORMATION CONTAINED IN THIS DRAWING IS THE SOLE
PROPERTY OF LINE 6 INC. ANY REPRODUCTION IN PART OR WHOLE
WITHOUT THE WRITTEN PERMISSION OF LINE 6 INC. IS PROHIBITED

COMPANY:	LINE 6
TITLE:	A8-7 SPIDER3 HD75 POWER SUPPLY
PROGRAM:	PADS POWER LOGIC V5.0
REV:	X0
FILENAME:	A8-7 MAIN_LED_REV X0.sch
SCALE:	1:1
SIZE:	C
PART NUMBER:	35-00-0311 35-00-0311-1
SHEET:	4 OF 4

DRAWN:	T. BURTON	DATED:	11/10/2005
CHECKED:		DATED:	

L6D000110 / L6D000112 – SPIDER III A8-2/A8-5 CABINET ASSEMBLY INSTRUCTIONS

59-00-0021-X (1508, A8-2)

59-00-0022-X (3012, A8-5)

Rev B



Figure 1



Figure 2

Special Notes

These instructions apply to the mechanical assembly of the Spider III 1508 and 3012 speaker cabinets. This document supplements the 50-03-0038 (1508) and 50-03-0041 (3012) engineering drawings

This document is intended for the cabinet vendor and does not include any chassis assembly details. The instructions begin with a carpeted box sub-assembly and specify the installation of all mating cosmetic components.

A note on the text: the illustrations in this book are for reference only. In some cases, color and geometry of illustrations may not accurately reflect the color or exact geometry of actual parts.

- Unless otherwise noted, all dimensions are in MM.
- Part identifying notes are in this format: Description (Part Number)
- Drawings are not to scale.
- Torque value tolerance +/- .5 in.-lbs. Do not over tighten any components.

For clarity, not all component details are shown. This is especially true with respect to cable assemblies. They are often omitted from views to provide a clearer picture of the material discussed. Do not be confused by the absence (or unexpected presence) of any component in the illustrations in this book.



Revision Comment Sheet

Revision	Changes
A	Update references to Spider II and revise to Spider III part numbers. Add instructions for installing Line 6 logo plate & logo.
B	ECO 0632501. Deleted Step 7. Revised Step 6 to incorporate the 30-27-0204 Logo Plate.

STEP 1: Mount speaker in cabinet, Note the orientation of the speaker terminals.

1508 (A8-2)
Cabinet: 50-03-0038
8" Speaker: 11-20-0006

3012 (A8-5)
Cabinet: 50-03-0041
12" Speaker: 11-20-0003

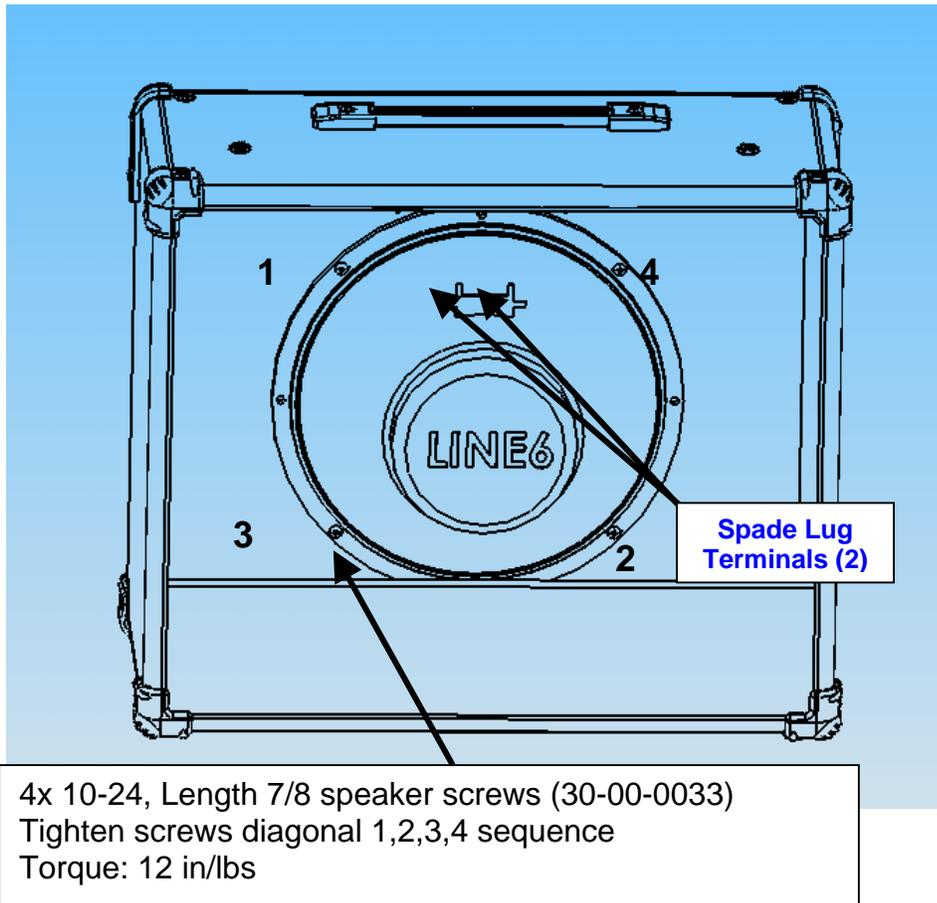

STEP 2: Install the Baffle Board brace onto the baffle board as shown using five (5), #8 x 5/8" screws.

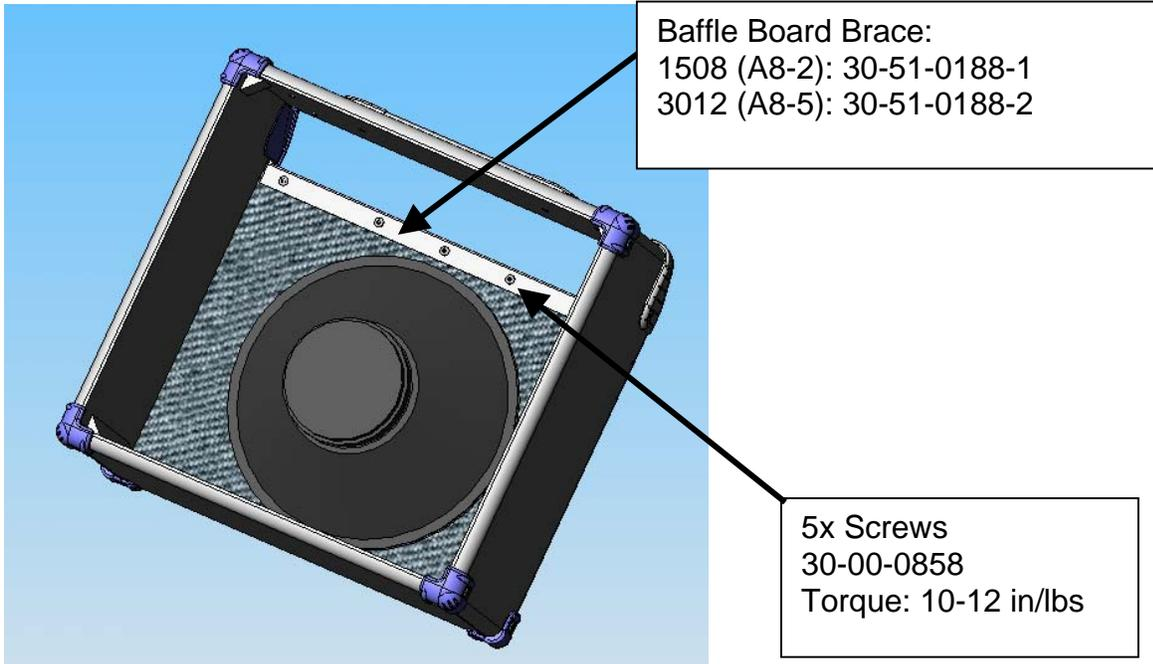

Step 3: Install rear kickboard after speaker installation using five (5) wood screws.

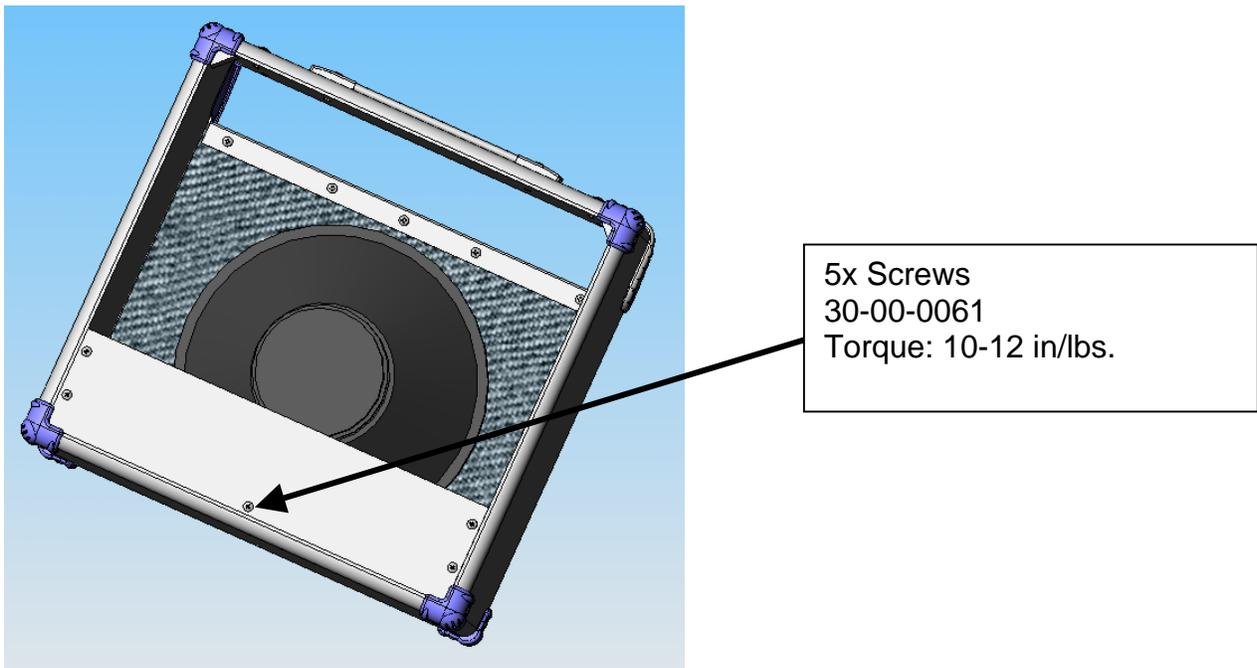

Step 4: Install chassis assembly into cabinet. Rotate chassis assembly into position as shown below.

1508 (A8-2) Chassis Assembly: 50-03-0038-X
3012 (A8-5) Chassis Assembly: 50-04-0038-X

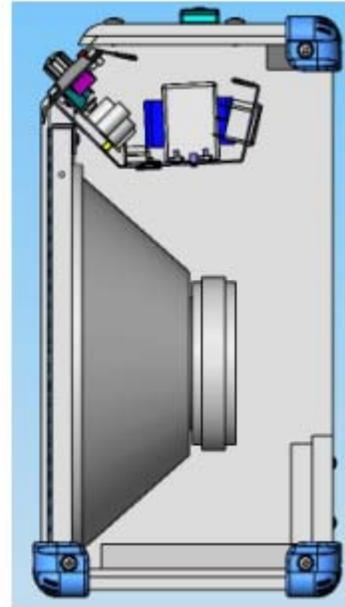
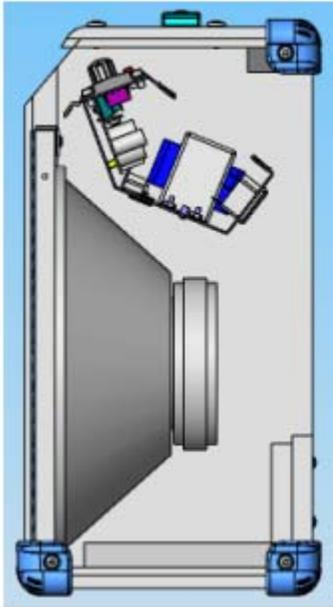

Step 4: (Continued)

Secure chassis to cabinet using four finishing washers (30-03-0112) and four 10-24x 1/4" machine screws (30-00-1020). Torque 8-10 in/lbs.

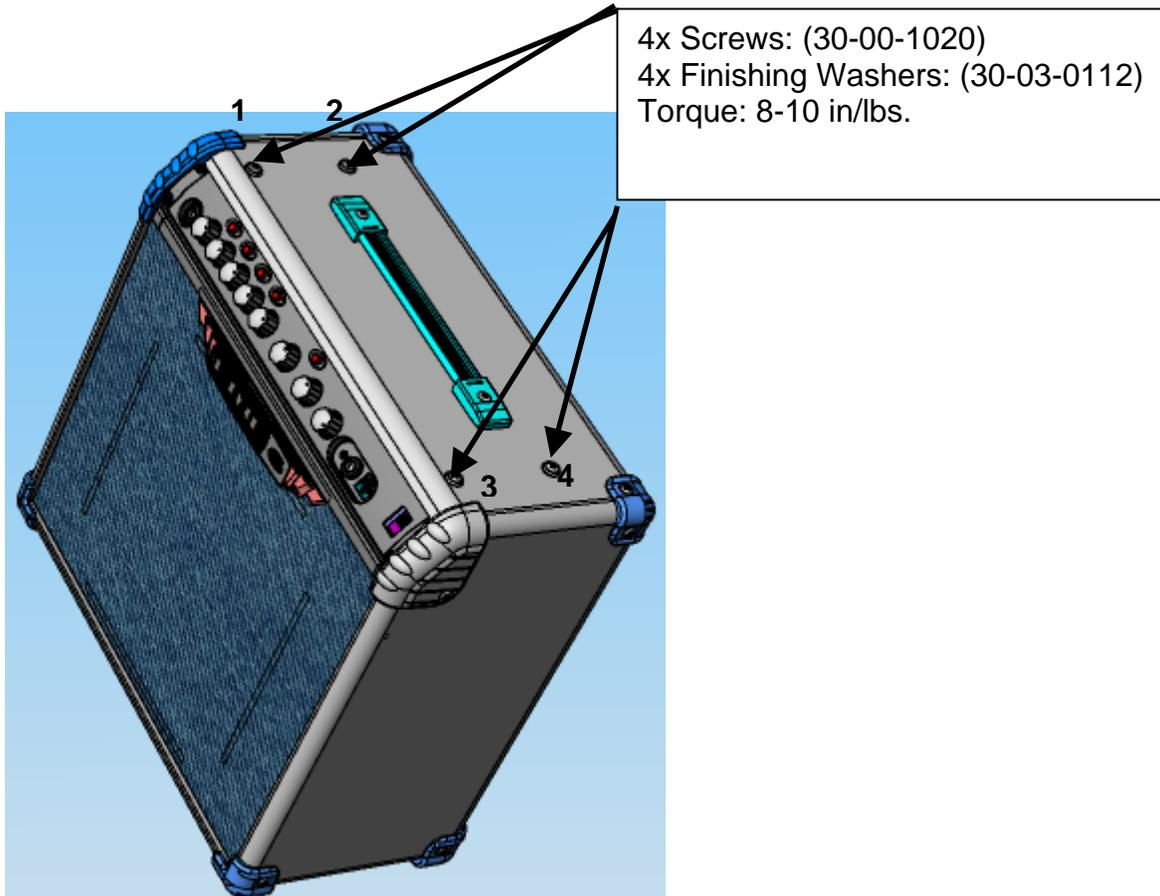



Step 5: Connect speaker wire terminals to speaker terminals. Connect white to the (+), and the black to unmarked (-) terminal.

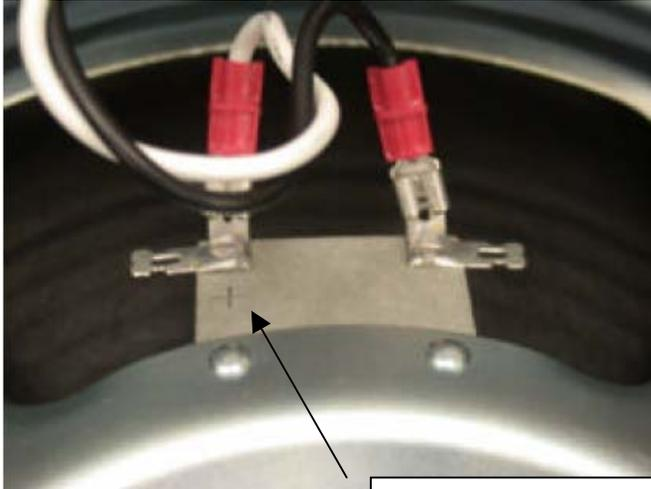

(+) Speaker Terminal

STEP 6: Slide Logo Plate (30-27-0204) into front panel slot. Top portion of logo plate will mount behind front panel. Secure Logo Plate to cabinet using 2 screws P/N 30-00-0676. Torque: 10-12 in/lbs.

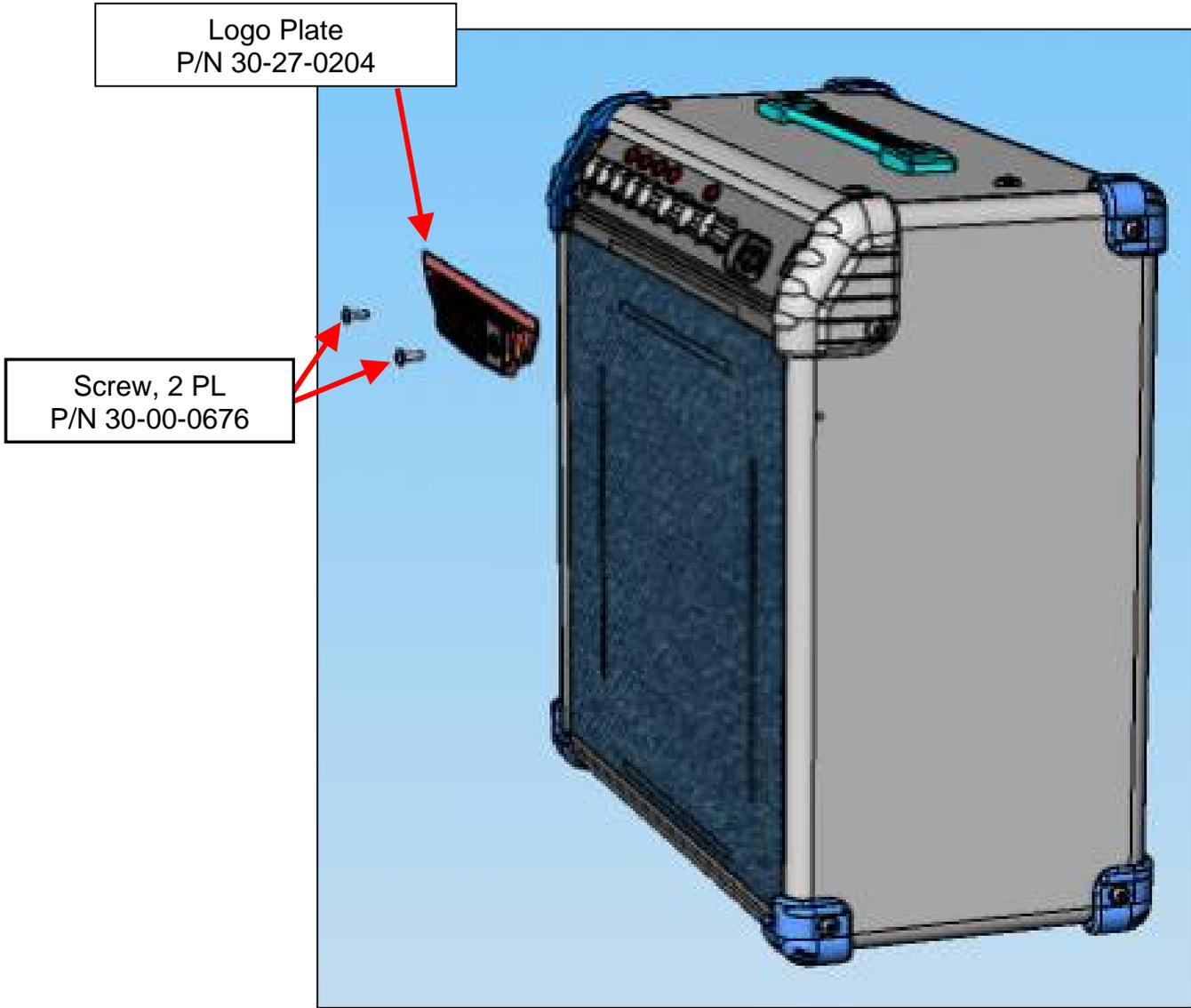

Spider III 1508/3012 A8-2/5 Mechanical Assembly Instructions Rev C

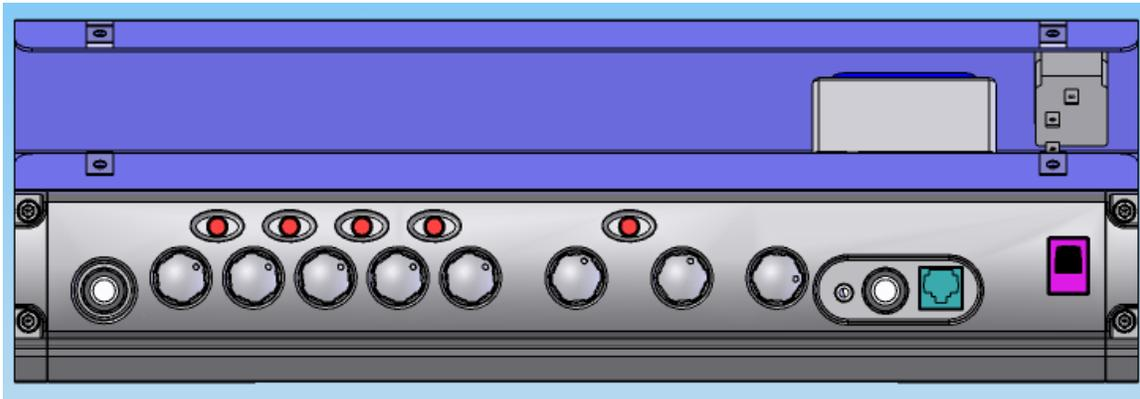

Forward and Notes

The information in this booklet applies to the mechanical assembly of the Spider III chassis. See also the Related Electrical assembly documentation, for major considerations in assembling the electrical components of the PCBs (through the soldering process and preparation of the board for addition of custom components).

A note on the text: the illustrations in this book are for reference only. In some cases, color and geometry of illustrations may not accurately reflect the color or exact geometry of actual parts.

- Unless otherwise noted, all dimensions are in MM.
- Part identifying notes are in this format: Description (Part Number)
- Drawings are not to scale.
- Torque value tolerance +/- .5 in.-lbs. Do not over tighten any components.

For clarity, not all component details are shown. This is especially true with respect to cable assemblies. They are often omitted from views to provide a clearer picture of the material discussed. Do not be confused by the absence (or unexpected presence) of any component in the illustrations in this book.



Revision Comment Sheet

Revision	Changes
X0	N/A
X0	Miscellaneous typographical errors corrected
A	Revised assembly steps and assembly detail.
B	Revised Step#20. Removed 30-63-1550 and changed quantity for 30-63-1325 to 4. Revised Step#13,14 to correct missing parts in power amp assembly to chassis. Revised Step#26. Documentation Error. Changed H5 to H6. Revised Step#11 – Changed screw (30-00-0043) to 30-00-0375. ECO#0629201
C	Added Step#28 for placement of ETL label.

Step 1. Install grommet (30-75-9600) into chassis.

Spider III 1508 Chassis: 30-51-0258

Spider III 3012 Chassis: 30-51-0259-1

(Use same instructions for SPIDER III 1508 and 3012).

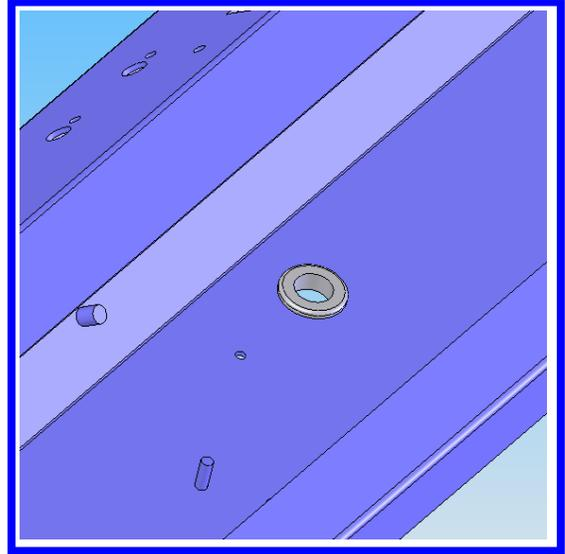
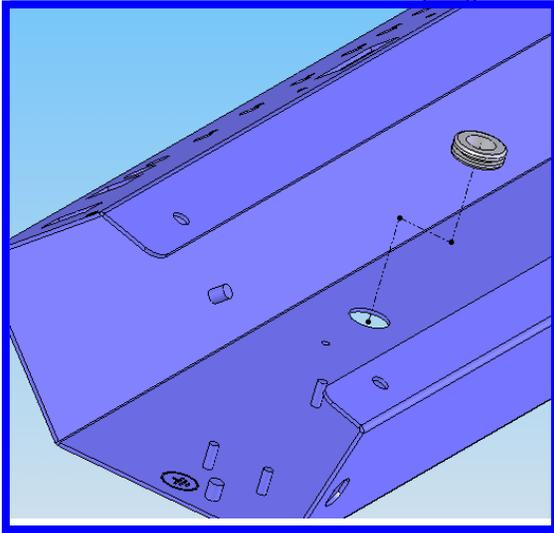

Step 2. Install thermal pad (30-63-4003) on the power amp, mounting hole.

(Use same instructions for SPIDER III 1508 and 3012.)



Step 3. Install Power Switch (24-24-0606). The switch should snap securely into place with the “I” above the “0”.

(Use same instructions for SPIDER III 1508 and 3012)

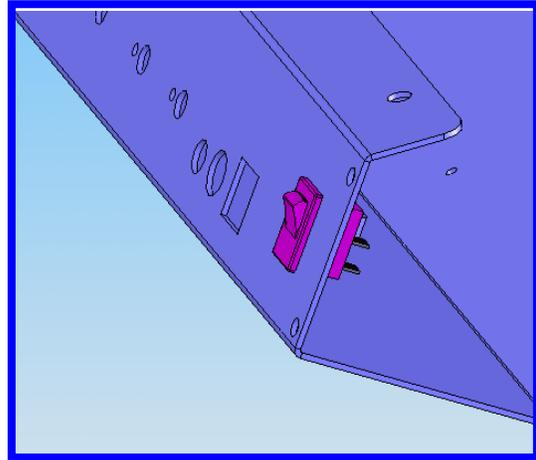
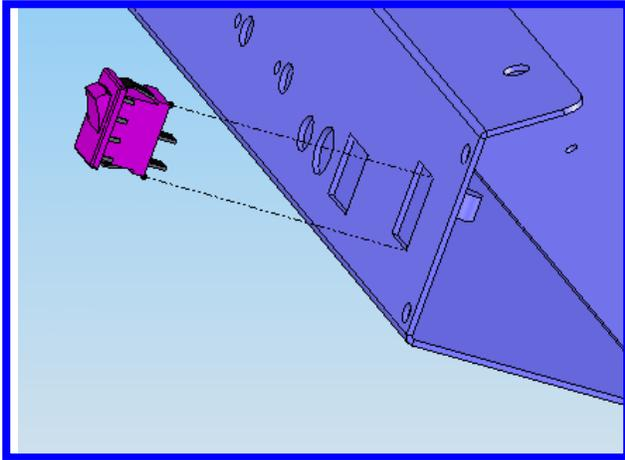

Step 4: Install AC receptacle assembly (50-00-0001)

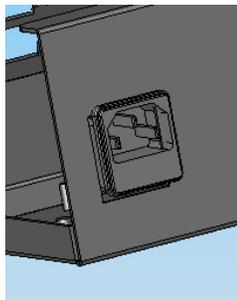
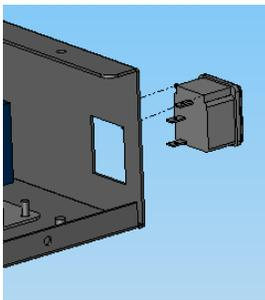

Step 5: Open fuse holder, install fuse, close fuse holder. Use the table below to determine the fuse value.





Finished Goods P/N	Use 0.5A/250V Fuse (P/N: 24-19-5000)	Use 1A/250V Fuse (P/N: 24-19-0002)
99-010-2601 [SPIDER III 30 (A8-5) AU]	X	
99-010-2602 [SPIDER III 30 (A8-5) EU]	X	
99-010-2604 [SPIDER III 30 (A8-5) UK]	X	
99-010-2501 [SPIDER III 15 (A8-5) AU]	X	
99-010-2502 [SPIDER III 15 (A8-2) EU]	X	
99-010-2504 [SPIDER III 15 (A8-2) UK]	X	
99-010-2603 [SPIDER III 30 (A8-5) JA]		X
99-010-2605 [SPIDER III 30 (A8-5) US]		X
99-010-2503 [SPIDER III 15 (A8-2) JA]		X
99-010-2505 [SPIDER III 15 (A8-2) US]		X

Step 6: Connect green/Yellow ground wire to PEM stud in chassis using a 6-32 screw (30-00-0043). Torque 8 in/lbs. Apply loctite P/N 21463 (Threadlocker 222) or equivalent, to screw and PEM stud after installation.
 (Use same instructions for SPIDER III 1508 and 3012).



Step 7: Clip tabs and break away Switch PCBA (50-02-0310-1) and Power amp PCBA (SPIDER III 1508: 50-02-0060; SPIDER III 3012: 50-02-0310-2) From Main PCBA.

Switch PCBA (50-02-0310-1)

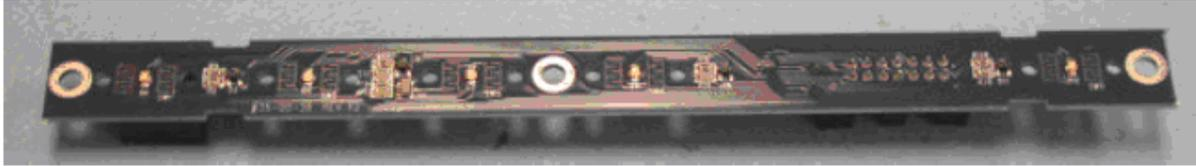

Power Amp PCBA: Spider III 1508 (50-02-0060) or Spider III 3012 (50-02-0310-2)

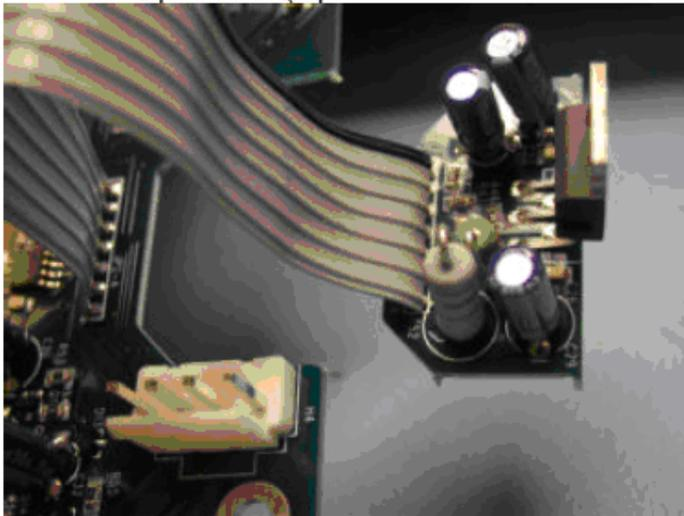

Step 8: The speaker cable (21-34-0055) should have 1 twist per inch.
(Use same instructions for SPIDER III 1508 and 3012)



Step 9: Attach the speaker cable (21-34-0055) to H4 on the main PCBA.
(Use same instructions for SPIDER III 1508 and 3012).

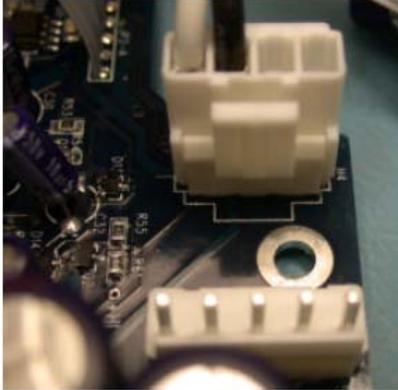

Step 10: Install Main PCBA into chassis.
SPIDER III 1508 Main PCBA: 50-02-0058
SPIDER III 3012 Main PCBA: 50-02-0310

Secure Main PCBA to chassis by installing 6-32 screw (30-00-0043), to chassis PEM stud.
IMPORTANT: only partially tighten screw.

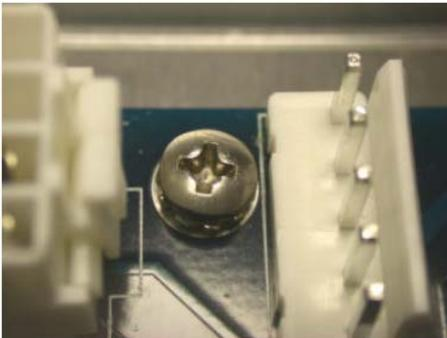

Step 11: Install Switch PCBA (50-02-0310-1) to front panel using three, 6-32 x .375 screws (30-00-0375). Torque 6-8 in/lbs. Apply Loctite P/N:21463 (Threadlocker 222) or equivalent, to exposed screw threads after assembly.
(Use same instructions for Spider III 1508 and 3012)



IMPORTANT: Power amp IC must be secured perfectly flush to chassis. Power amp IC is ESD sensitive. Use appropriate precautions when handling part.
(Use same instructions for SPIDER III 1508 and 3012).

Step 12: Install shoulder bushing (30-15-0404) into power amp mounting hole.
(Use same instructions for Spider III 1508 and 3012).



Step 13: Place power amp IC on thermal pad. Install a #4 x 1/2" screw (30-00-0402) through chassis and plastic washer.

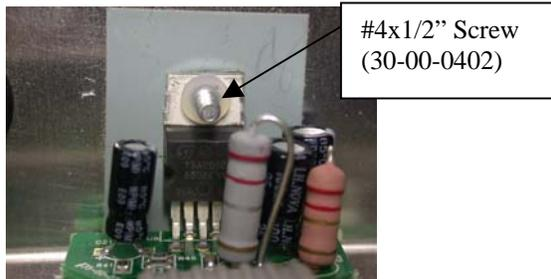

Step 13: Continued.

Install #4 washer (30-03-0425), split lock washer (30-03-0400) and hex nut (30-06-0440).
 Torque 8-10 in/lbs.

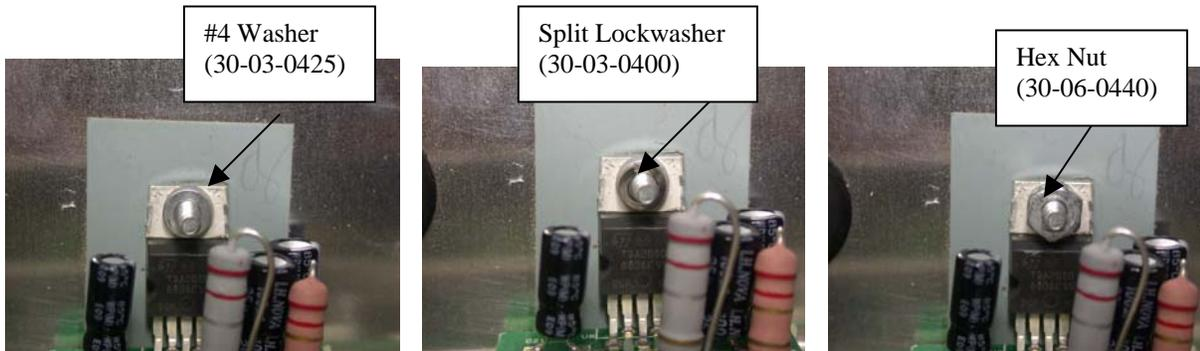

Step 14: Use the table below to determine which transformer wire is not used.

Finished Goods P/N	Transformer Part Number	Unused Transformer Wire
99-010-2501 [SPIDER III (A8-2) 15-AU]	11-30-0016	Yellow Wire
99-010-2502 [SPIDER III (A8-2) 15-EU]	11-30-0016	Red Wire
99-010-2503 [SPIDER III (A8-2) 15-JA]	11-30-0015	Red Wire
99-010-2504 [SPIDER III (A8-2) 15-UK]	11-30-0016	Yellow Wire
99-010-2505 [SPIDER III (A8-2) 15-US]	11-30-0015	Yellow Wire
99-010-2601 [SPIDER III (A8-5) 30-AU]	11-30-0014	Yellow Wire
99-010-2602 [SPIDER III (A8-5) 30-EU]	11-30-0014	Red Wire
99-010-2603 [SPIDER III (A8-5) 30-JA]	11-30-0013	Red Wire
99-010-2604 [SPIDER III (A8-5) 30-UK]	11-30-0014	Yellow Wire
99-010-2605 [SPIDER III (A8-5) 30-US]	11-30-0013	Yellow Wire

Apply standard electrical tape over the unused terminal and then use a cable tie (30-24-0003) to secure the tape.

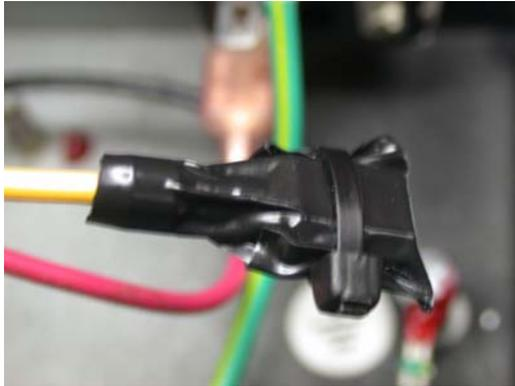

Step 15: Install transformer into chassis as shown in picture below. Secure transformer to chassis using hex nuts (P/N: 30-06-0832). Torque to 12 in/lbs. Apply loctite P/N: 21463 (Threadlocker 222) or equivalent, to exposed screw threads and hex nuts after installation. Transformer must be installed with secondary wires (Red, Black, Blue) facing the Main PCBA.

Spider III 1508 Transformer uses one hex on each side.



Spider III 3012 transformer uses two hex nuts on each side.



Step 16: Connect transformer secondary wires (5-pin connector) to H5 on Main PCBA.
(Use same instructions for Spider III 1508 and 3012).

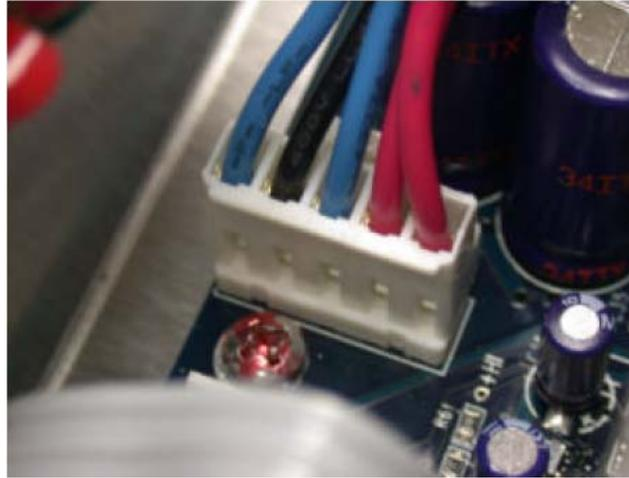

Step 17: Connect cable (21-34-1015) between the lower terminal of the AC receptacle and the lower terminal of the power on/off switch.
(Use same instructions for SPIDER III 1508 and 3012).

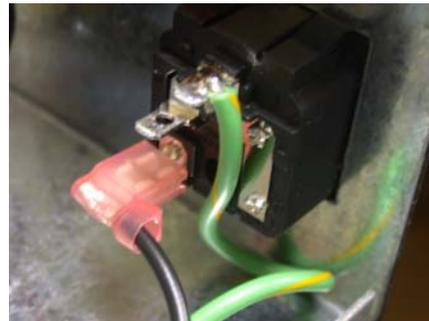
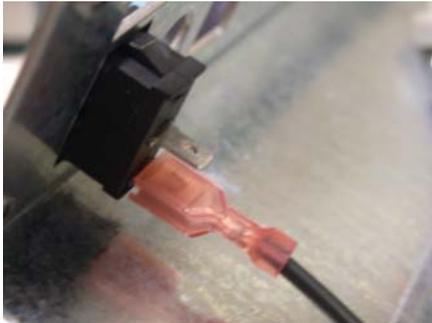

Step 18: Connect red or yellow transformer wire to top terminal of AC receptacle. Connect black transformer wire to top terminal of power on/off switch.
(Use same instructions for SPIDER III 1508 and 3012).

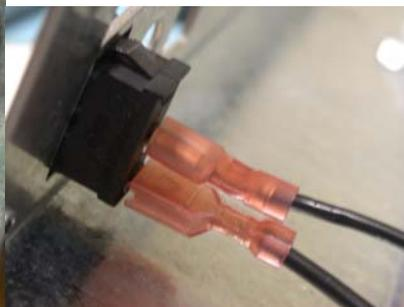
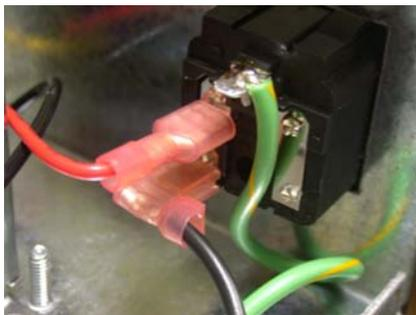



Step 19: Add cable ties (30-24-0003) to power on/off cables, and AC receptacle cables. Include unused transformer cable (red or yellow).

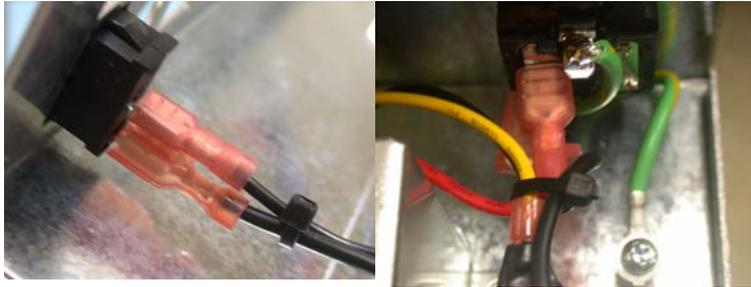

Step 20: Install adhesive foam strips on top and front of chassis as pictured below.

Use four pieces of adhesive foam (30-63-1325) for chassis top and front.
(Use same instructions for SPIDER III 1508 and 3012).

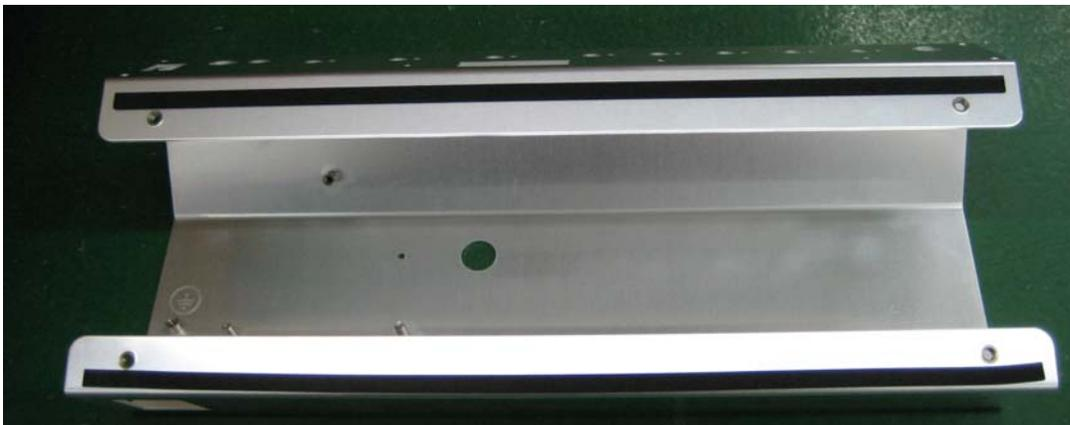

Step 21: Install rubber keypad (30-75-0020) onto switch PCBA.
(Use same instructions for SPIDER III 1508 and 3012)



Step 22: Install plastic front panel onto chassis and secure with four hex nuts (30-00-1033).
Torque 3-4 in/lbs

SPIDER III 1508- Use front panel (30-27-0189)
SPIDER III 3012- Use front panel (30-27-0191-1)

Install four hex nuts (30-00-1033), one at each corner of front panel.



Step 23: Install plastic hex nuts (21-00-6616) on Guitar and Phone jacks. Hex nuts are purchased with the jacks and use a common part number. Torque 4-5 in/lbs.
(Use same instructions for SPIDER III 1508 and SPIDER 3012).



Step 24: Install hex nut and washer on all eight potentiometers. The hex nuts and washers are purchased with the pots and have a common part number (01-48-0001). Install washers between front panel and hex nut. Washer not shown in view below. Torque 3-4 in/lbs.
(Use same instructions for spider III 1508 and spider III 3012).



Step 25: Tighten screw for Main PCBA to chassis PEM stud. Apply Loctite P/N: 21463(Threadlocker 222) or equivalent, To secure screw to PCBA.
(Use same instructions for SPIDER III 1508 and SPIDER 3012.)

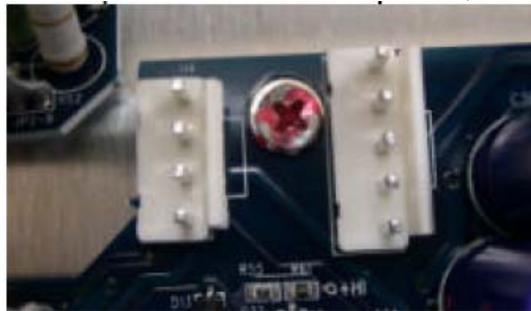

Step 26: Connect ribbon cable (H1) on Main PCBA to header (H6) on Switch PCBA. Apply RTV to cable connector and header to insure cable never comes loose.
(Use same instructions for SPIDER III 1508 and SPIDER 3012.)

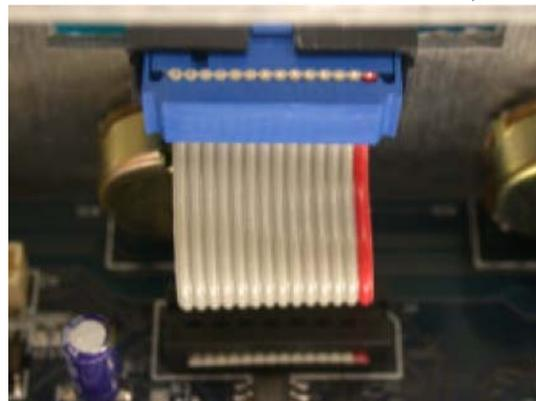

Step 27: Install plastic chrome knobs (30-45-0011) on all eight potentiometer shafts.
(Use same instructions for SPIDER III 1508 and SPIDER 3012.)



Step 28: FOR US/CANADA UNITS ONLY. Apply ETL label to chassis rear as shown in picture below. Each contract manufacturer must use their own unique label.

Kwanasia: 40-25-0030

Saitek: 40-25-0029

Spider III 30: Install ETL lable on chassis rear as shown in picture below.



Spider III 15: Install ETL label on inside of cabinet under the serial number label. Note: ETL label not show in picture.





(Completed unit)

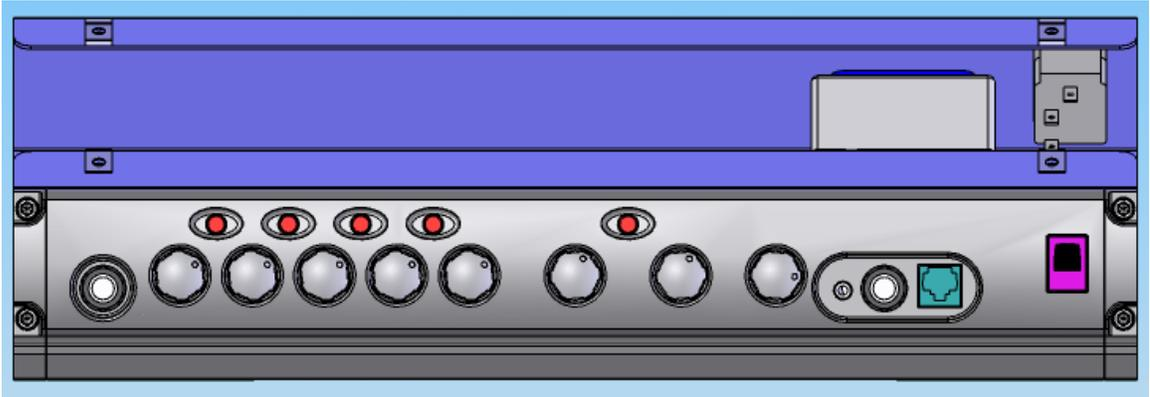

SPIDER 3 1508 / 3012 & LOWDOWN LD15
PCBA ASSEMBLY INSTRUCTIONS

Rev. C

SPIDER3-3012 ASSY: 50-02-0057 (Refers to PCB, Rev. B: 35-00-0310, 35-00-0310-1, 35-00-0310-2)

SPIDER3-1508 ASSY: 50-02-0056 (Refers to PCB, Rev. B: 35-00-0310, 35-00-0310-1, 35-00-0310-2)

LOWDOWN LD15 ASSY: 50-02-0089 (Refers to PCB, Rev. B: 35-00-0310, 35-00-0310-1, 35-00-0310-2)

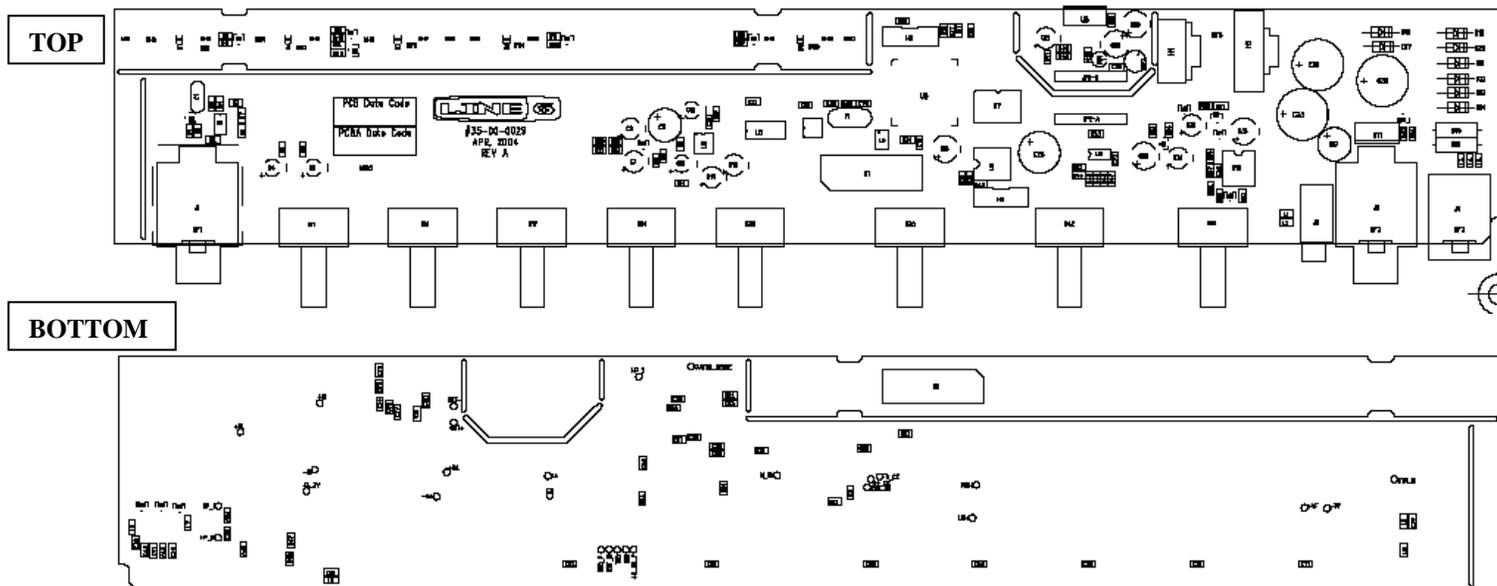

1. **DO NOT INSTALL PARTS FOR 3012 ONLY:**
R4, C1, H2, JP2-3
2. **DO NOT INSTALL PARTS FOR 1508 and LD15 ONLY:**
R4, R50, R68, J4, L3-L7, U12, D25-27, GF3, C1, C39-43, C78-80, H2, Y1, JP1, JP4
3. **BREAKAWAY SECTIONS: DO NOT BREAK APART THE SECTIONS OF THE PCB.**
4. **INSTALLATION OF HEADERS, DIODES AND CAPACITORS:**
Check orientation of all headers. All headers must be mounted flush to PCB.
 - Install 14-pin ribbon cable (21-30-0029) H1 as shown in picture below:

LINE 6

Engineering



- The edged tab of H4 (21-20-1564) and H5 (21-20-1565) should face the right edge of the board.

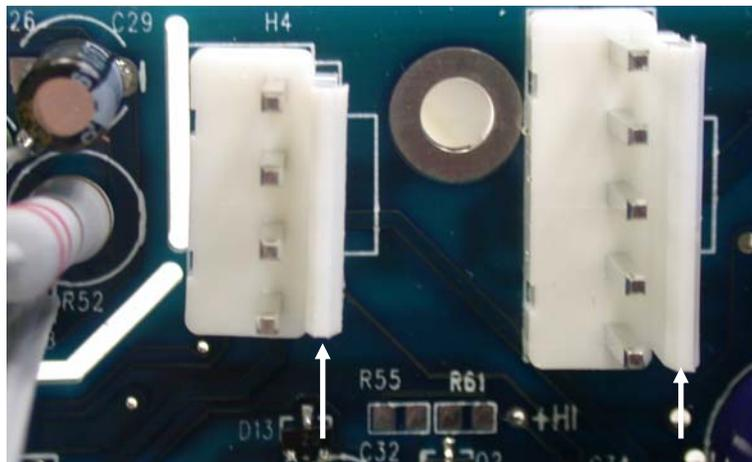

- DO NOT INSTALL H2
- The edged tab of H3 should face the top of the board.
- Check for installation and correct orientation of diodes D16, D17, D19-24.
- Check for the installation and correct orientation of all electrolytic capacitors.
- **Note that the orientation of C20 is opposite of all other electrolytic capacitors.**

LINE 6

Engineering

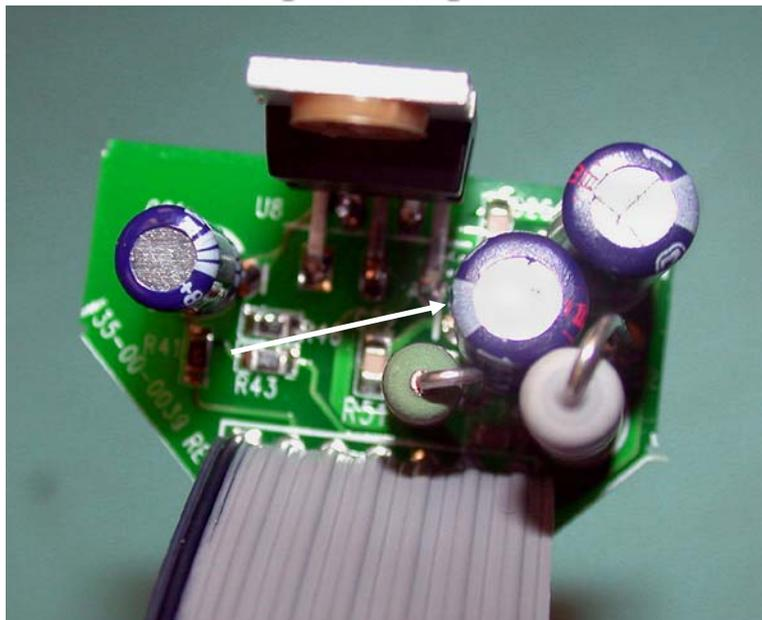

5. **POTENTIOMETERS:** All potentiometers are mounted on the **TOP SIDE** of the PCB, flush to the PCB, and as straight as possible. (Within +/- 1 degree)

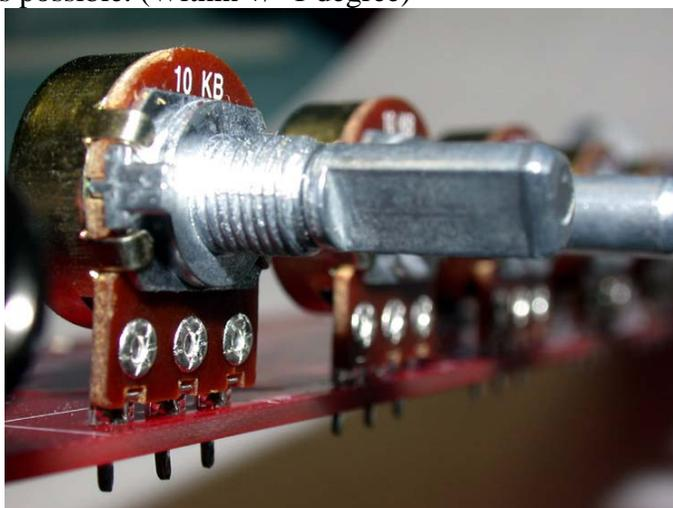

DO NOT WATER WASH THE BOARD: The potentiometers are sensitive to water washing. If wave soldering is preferred, we recommend using a no-clean flux wave soldering process, rather than a process that requires washing.

LINE 6

Engineering

6. **GROUNDING FINGERS:** Grounding fingers GF1-3 (30-18-3030) are mounted flush against the PCB edge. It is mounted with its center clip hole on the **BOTTOM SIDE** of the PCB. The “curl” of the grounding finger should curve toward the Top side. **It should then be manually soldered on the BOTTOM SIDE.**

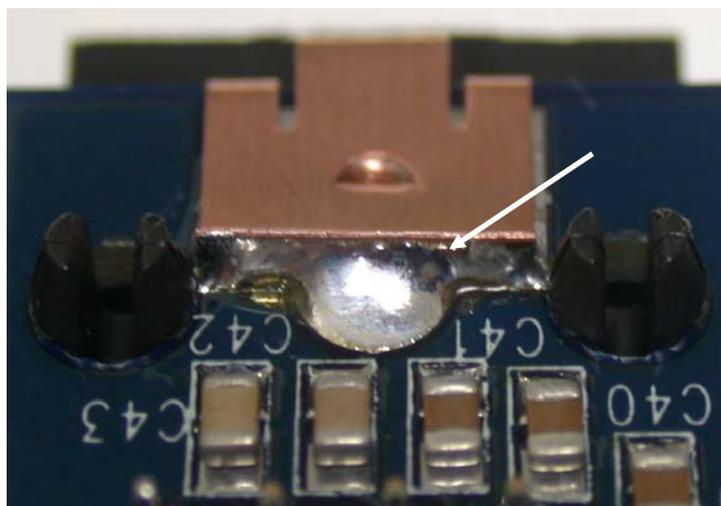
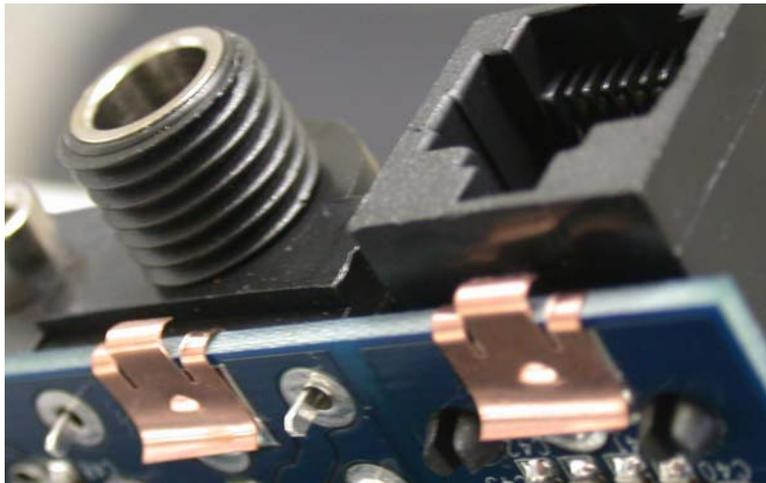

7. **INSTALLATION OF RIBBON JUMPER:**

- A 7-pin ribbon jumper cable (21-30-0014) will be installed between JP2A on the MAIN PCB (35-00-0310) and JP2B on the POWER AMP PCB breakaway (35-00-0310-2).

LINE 6

Engineering

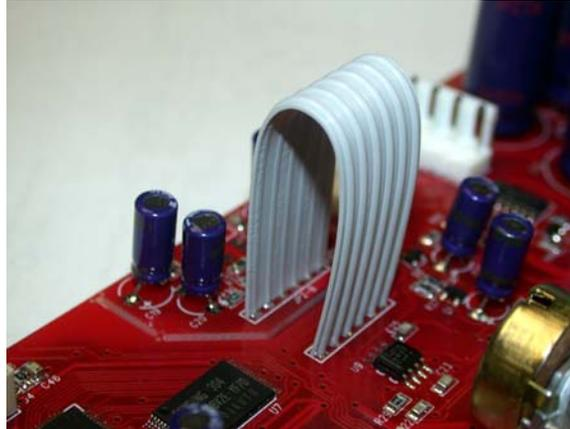

8. **APPLY RTV TO ELECTROLYTIC CAPACITORS:**
Apply RTV as shown below to C28,C35-C38

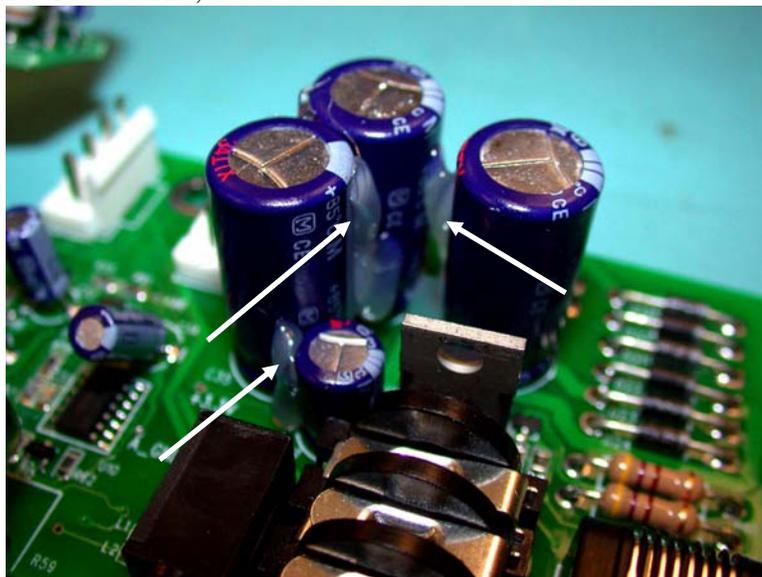



9. **3012 / 1508 CHECK BOX:**

Mark 1508 or 3012 check box below Line6 logo to indicate either a 1508 or 3012 PCB.

For LD15, mark the 1508 check box.



10. **FOR 3012 ONLY: INSTALL CRYSTAL AND CRYSTAL INSULATOR:**

For 3012 only, install crystal Y1 with the insulator (30-15-0007). Make sure both are mounted flush with the PCB.

This is NOT required for the 1508 or LD15.

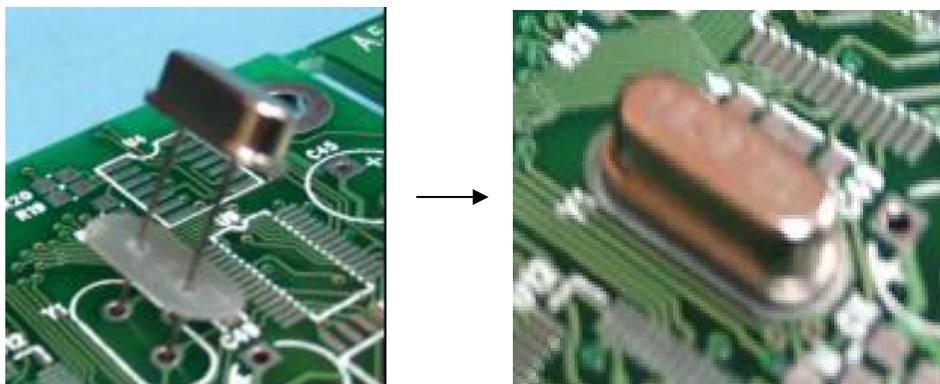

- END OF PCBA INSTRUCTIONS -

SPIDER3 1508/3012 & LOWDOWN LD15

PCBA ASSEMBLY INSTRUCTIONS REVISION CHANGE HISTORY

REVISION	NOTES	DATE	RELEASED BY
A	- Initial Release - For Rev B Production Build.	07/29/06	Justin Brennan
B	- Added references to LowDown LD15.	07/16/08	Mike Paganini
C	- Added notes to indicate that Step 10 is for 3012 only.	07/21/08	Mike Paganini