

MANUAL NO. 993-040660-001  
PRICE \$ 5.00

# TECHNICAL SERVICE MANUAL for

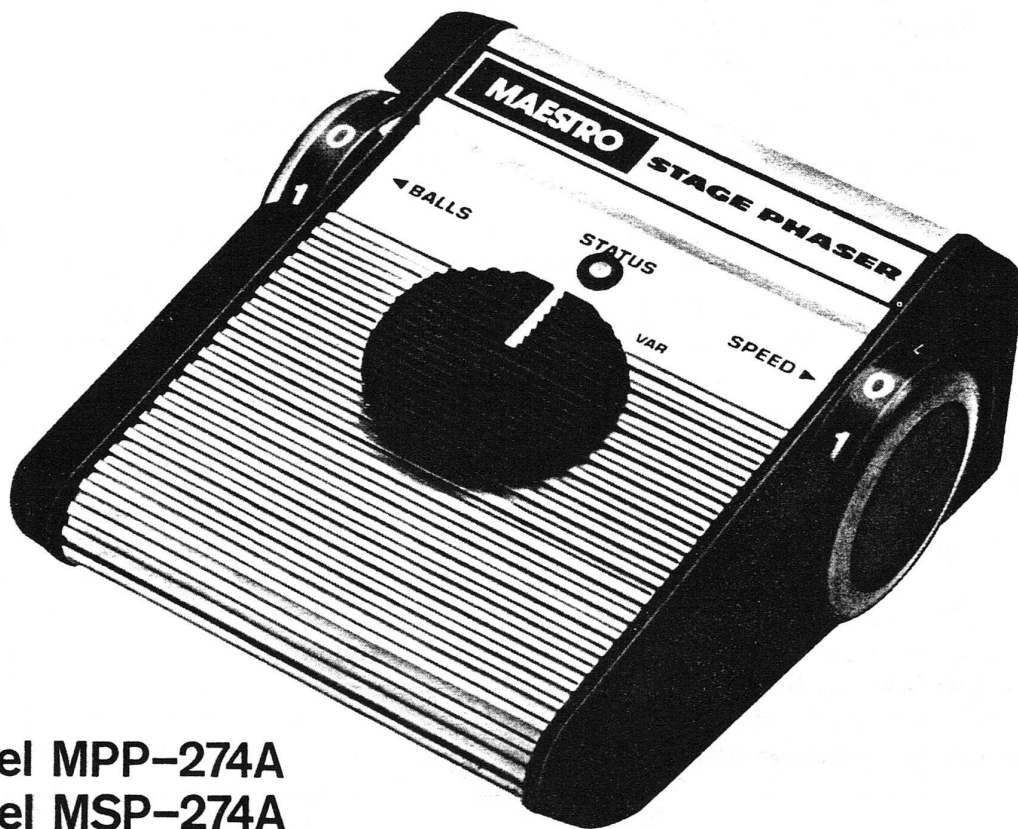

Model MPP-274A  
Model MSP-274A

2500 Walden Ave.  
Buffalo, N.Y. 14225



NORLIN MUSIC  
(716) 681-7242

## INTRODUCTION

This manual provides servicing and parts information for Maestro Model MPP-274A and Model MSP-274A Stage Phaser, manufactured by Moog Music, Inc., 2500 Walden Avenue, Buffalo, New York 14225. The Maestro Stage Phaser generates variable or preset phasing speed effects for guitar, bass and other electroacoustical music signals.

Input Impedance .....	1 megohm
Maximum Recommended	
Input Level .....	-10dBm
Output Impedance .....	10K ohms
Insertion Loss .....	0db
Output Noise .....	-85dBm
Phasing Stages .....	6
Range of Variable SPEED	
Control .....	0.10 Hz to 6.5 Hz
Frequency of Speed "1" .....	2.0 Hz
Frequency of Speed "2" .....	6.0 Hz

### Power Requirements:

Battery Operation (Excludes	
Lamp Current).....	9 VDC at 3.5 milliamperes nominal
External DC Source Operation....	12 VDC at 150 milliamperes
Maestro Battery Eliminator .....	115-230 VAC, 50-60 Hz, 3 watts
Recommended Battery Type .....	NEDA 1604
Estimated Battery Life.....	100 hours

## CIRCUIT DESCRIPTION

The Stage Phaser produces phasing effects by movement of an active filter and consists of: (1) an input buffer and summing amplifier section which conditions the input signal from the signal source; (2) a six stage current controlled phase shifting chain

which generates the phasing effect; (3) a low frequency triangle oscillator and exponential current source which drives the phase shift chain; and (4) a power supply section which powers the unit. Operating controls consist of a SPEED control which adjusts the phasing rate, a BALLS control which adjusts the phasing effect, an internal foot switch which selects either the output of the phase shift chain or the unaltered signal and an external foot switch which selects two preselected phase shifting speeds or a VARIABLE speed control. (Refer to Figure 4 for the schematic diagram.)

### Input Buffer and Summing Amplifier

In the phasing mode, the input signal from AXE jack J1 is coupled to input buffer IC1A converting the source's high input impedance to a low output impedance for driving summing amplifier IC1B. IC1B inverts the signal, adds a gain of 1.5 and sums the output signal from BALLS control R9 with the input signal. The output of summing amplifier IC1B drives the phase shift chain. Resistors R3, R4 and capacitor C2 form a pre-emphasis circuit for an improved signal-to-noise ratio by increasing the gain by 6dB/octave starting at 5kHz and leveling off at 23kHz.

### Six Stage Phase Shift Chain

The phase shift chain starts with IC2, an operational transconductance amplifier (OTA) with a Darlington output stage. The OTA has a current output with very high output impedance while the Darlington stage isolates the output of the OTA from the load. IC2 is used as a current controlled phase shift element and, with surrounding circuitry, can be substituted by the simple equivalent circuit illustrated in Figure 1.

The signal from IC1B is coupled through C6 and  $R_c$  in series with an inverter resulting in a network

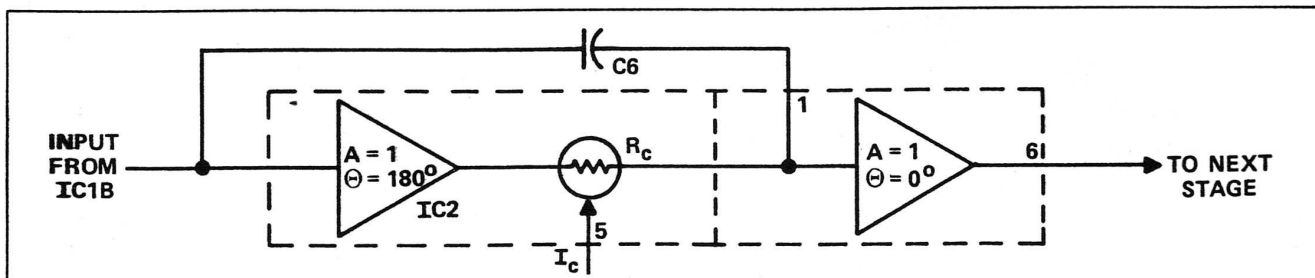

FIGURE 1 SIMPLE EQUIVALENT CIRCUIT

with a gain of one and a frequency dependent phase shift. With a dc input, C6 has no effect on phase resulting in a phase shift of 180 degrees. As the frequency increases, C6 comes into effect and the phase shift heads toward 360 degrees. At a frequency equal to  $2\pi R_c C$ , the phase shift is 270 degrees. The value of  $R_c$  is controlled by  $I_c$  into pin 5. As  $I_c$  increases, the effective value of  $R_c$  as well as the phase decreases but gain remains the same. Therefore, the phase shift is current controlled.

IC3 through IC6 operate in a manner identical to IC2. The phase shift of each stage adds to all previous stages and since they are driven by the same current from Q5B, they move together. The five moveable stages are followed by a stationary stage, IC10A. This phase shift is fixed and operates the same as the equivalent circuit with  $R_c$  replaced by R74 adding a fixed phase shift to the chain. The output of IC10A drives BALLS control R9 and R71. R70 and R71 sum the outputs of IC10A and the original signal resulting in cancellation of the signal at frequencies where there are 180 degree phase shifts. With 100 microamperes of current through Q5B, these frequencies are 560 Hz, 2.25 kHz and 8 kHz. These notch frequencies move with the control current resulting in the phasing effect. BALLS control R9 applies positive feedback around the phase shift chain resulting in resonant peaking between notches. At our example current, these frequencies are 35 Hz, 1.2 kHz and 4.1 kHz.

#### Low Frequency Oscillator and Exponential Current Source

A triangle generator is formed by IC7 and IC8B. IC7 provides a constant current at pin 1 of IC7 which is proportional to the control current entering pin 5. Therefore, capacitor C15 is charged by a constant current source and forms a linear ramp generator. The voltage at pin 6 is the capacitor voltage minus 1.2 volts from the Darlington buffer portion of IC7. The ramp of IC7 is connected to a Schmidt trigger IC8B of 4.2 volts for negative switching and 2.0 volts for positive switching. The output of the Schmidt trigger is coupled through R68 and R69 to the positive input of IC7. Capacitor C15 charges until pin 6 reaches the positive trip point of 4.2 volts, the output of IC8B switches negative and C15 discharges to the negative trip point of 2 volts. The charge rate is dependent on the current entering pin 5 of IC7. The

higher the current, the higher the frequency rate of the triangle generator. IC7 is a CA 3094 capable of a 3-volt differential on its input before damage results to the device. Protection is provided through the voltage divider composed of R68 and R69. The inputs of IC7 are saturated so that current at pin 6 is equal to the control current at pin 5. This forms a self-sustaining dual slope integrating triangle oscillator. The triangle waveform from IC7 is applied to a lowpass shelf filter composed of R58, C16, R62 and R63. This filter reduces the amplitude of the triangle wave at higher frequencies to maintain smooth phasing. The filter output is applied to the input attenuator for exponential current source Q5A which reduces the signal level at the base of Q5B to a maximum of 120 mV. Exponential current source Q5A comprises a matched pair of NPN and PNP transistors and a constant current sink, Q6. When the voltage at the base of Q5A equals the 4.5 volt supply, collector current from Q5B equals the current through Q6 which is adjusted by center trimpot R67. This adjustment affects the center point of the phase shift chain. When the base of Q5 decreases 18 mV below the 4.5 volt supply, current from Q5B doubles from its previous value. Another 18 mV decrease results in another doubling and vice versa. This circuit changes the linearly varying triangle to an exponential varying current. The 120 mV drive from the filter to Q5B results in six octaves of current. To allow for power supply voltage drop due to battery age, Q6 (E101) provides a constant current source independent of voltage changes. This maintains a constant phasing effect with battery age.

#### Motor Start/Stop Simulation

The Stage Phaser has a simulated motor start/stop effect with selectable final speeds equivalent to 2 revolutions per second or 6 revolutions per second. In order to understand this, assume SW2 is open and C12 is fully discharged. Then, the emitter of Q2 is grounded which cuts the control current fed to pin 5 of IC7 stopping the triangle oscillator. R57 slowly charges C15 to +9.0 volts shutting down the exponential current source Q5 to reduce battery drain. The emitter voltage of Q2 also turns Q3 on feeding current to IC9 and IC11. IC9 feeds the input signal directly to the last phase shift element IC10A. The signal current from IC9 is so strong that it swamps out the phase shift signal. R70 and R71 maintain the circuit gain at -1. The original signal is de-emphasized

by R77, R78 and C21 and appears at J3. IC11 applies so much negative feedback around IC10B that it reduces the output of IC10B by 40dB. Therefore, the AUX output J4 is "dead" compared to the main output. When SW2 is closed, +9.0 volts is applied to R36. This charges C12, and the emitter voltage of Q2 follows. The triangle oscillator is slowly brought up to speed. Q3 is slowly turned off, slowly turning off IC9 and IC11, and normal phasing is restored. The time constants of R36 and C12 are chosen so that this simulates the starting of a motor driven speaker. When SW2 is again opened, C12 gradually discharges to simulate a speaker slowly coming to a stop.

### Power Supply

The Stage Phaser can be operated from either a 9.0 volt battery or a 12 volt DC 150 ma battery eliminator. When using the 12 volt supply, wheel lamps L1 and L2 and STATUS LED L3 operate. L1 and L2 luminate the wheel at all times. The Schmidt trigger IC8B drives Q4 which flashes the STATUS light L3 on and off at the sweep rate, whenever the unit is in the phasing mode. Both the lamps L1 and L2 and the STATUS LED L3 are powered from a capacitance multiplier Q1 which keeps the hum on the battery eliminator from entering the unit. The raw DC is also applied to zener diode CR2 producing a regulated 9.0 volt supply for the rest of the electronics. CR1 isolates the battery when using the eliminator, and CR3 isolates the zener when using the battery. R60, R61 and IC8A provide a low impedance 4 volt supply at approximately half the main supply voltage as a reference or synthetic ground.

### DISASSEMBLY

- a) Pull out plungers on battery holder assembly (1) of Figure 2 and remove battery holder assembly. Disconnect battery (2) if present and remove.
- b) Loosen setscrews (3) securing dial assemblies (4 and 5) by inserting a 1/16-inch Allen wrench through holes in dial assemblies and remove dial assemblies. Lift off foot control assembly (6).
- c) Remove nut (7) using a half inch nut driver, lock washer (8), three screws (9) and screw (10) from each end cap (11) and remove both end caps.

### CAUTION

Do not set Stage Phaser on its side when removing second end cap as damage to rotary pot shaft or light assembly may result.

d) Position Stage Phaser face down and carefully slide hinge assembly (12) out of housing assembly (32) making certain compression spring (13) around push switch assembly (19) does not fly off and remove spring.

e) Disconnect both four and two pin connectors on printed circuit board assembly (18) noting red wire on left side of four pin connector and white wire on left side of two pin connector.

f) Remove nuts (14) using a half inch nut driver and flat washers (15) from AXE, AMP and AUX. OUT jacks. Remove nut (16) using a 3/8-inch drive and flat washer (17) from EXT. D.C. jack and carefully remove printed circuit board assembly (18).

g) Loosen hex nut (20), lock washer (21) and flat washer (22) and slide out push switch (24), lock washer, and hex ring.

h) Carefully slide STATUS LED assembly (27) from clear lens/bushing (33) and remove LED assembly.

i) Slide foot pads and/or clear lens/bushing (33) out of their channels if replacement is required.

### TEST, ADJUSTMENT AND TROUBLESHOOTING

The Stage Phaser requires an adjustment to set the phase shift chain to the correct reference frequency assuring the unit will sweep over the correct frequency range. When troubleshooting, refer to the circuit description, schematic diagram and replacement part lists. Observe dc voltage levels and ac signal levels as shown on the schematic diagram, using an oscilloscope. A high impedance voltmeter (1 megohm per volt or higher) may be used to measure dc voltage levels. Note that voltage levels and waveforms displayed on the schematic diagram are not absolute values as readings may vary between units. Once the problem is localized, check the suspected part by

direct substitution if possible. Otherwise use a voltmeter or oscilloscope to determine the malfunctioning part.

#### NOTE

All replacement parts may be obtained from Moog Music, Inc. However, many standard electronic parts may be obtained locally in less time than is required to receive them from Moog. When purchasing replacement parts locally, check the parts list for proper value, tolerance and rating.

a) Visually inspect unit for broken wires, damaged components, loose connections and other obvious defects.

b) Make certain unit is connected and operated according to Owners Manual or instruction label located on bottom of unit. If possible, check associated equipment such as cables, battery or amplifier used with the unit.

c) Turn BALLS and SPEED controls to "0" and variable resistor R67 full counterclockwise with SPEED SELECT switch in VAR position.

d) Connect a 9 volt power supply with a 0 to 10 ma meter connected in series to the battery clip and apply a 2.25 kHz, 100 mV peak-to-peak sine wave to AXE jack J1.

e) Connect an oscilloscope to output AMP jack J2 and a short clip lead across R64 (located on printed circuit board, Figure 3).

f) Adjust R67 for an indication of 2.5 ma on the milliamper meter and adjust R67 back and forth for a null indication on oscilloscope. Milliamper meter should indicate  $2.5 \pm 0.25$  ma.

g) Check for null indications at  $550 \pm 100$  Hz and  $8 \pm 1$  kHz. Adjust BALLS control to "9" and observe oscilloscope for a peak indication at  $1.2 \pm 0.1$  kHz with a voltage level of  $700 \pm 50$  mV peak-to-peak. Disconnect clip lead across R64.

h) Connect a 2 volt/centimeter, 20 millisecond/centimeter dc coupled scope probe to pin 7 of IC8. Set speed switch in VAR position with SPEED potentiometer set at 9. Adjust speed trimpot R38 for 1 cycle = 166 milliseconds. If phasing appears to stop or hesitate, replace IC8 and reset null and speed controls.

i) Replace matched pair, Q5, if phase shift chain will not setup properly.

j) If unit hums when using an external battery eliminator, hum may be from ripple on the lights appearing on the ground return path. Check transistor Q1 or diode CR2.

#### REASSEMBLY

a) Reassemble Stage Phaser in reverse order of disassembly referring to the exploded view (Figure 2) and noting the following additions.

b) Finger tighten nuts (14 and 16) securing printed circuit board assembly (18) to housing assembly (32) to allow printed circuit board assembly to fit into slots of end caps (11). After both end caps are installed, tighten nuts (14 and 16).

c) Connect four pin connector (25) to printed circuit board assembly (18) making certain red wire (pin 1) is on left side of connector at bottom of printed circuit board.

d) Connect two pin connector (30) making certain black wire (pin 7) is on right side of connector at bottom of printed circuit board.

e) Slip dial assemblies (4 and 5) on rotary pot shafts (left dial assembly (4) marked "L" between "9" and "0" and right dial assembly (5) marked "R" between "9" and "0") and turn each dial assembly full counterclockwise and then clockwise.

f) Turn right dial assembly full counterclockwise. Holding dial assembly steady at "0", insert small screwdriver in hole at center of dial assembly and turn pot shaft full counterclockwise then approximately five degrees clockwise to relieve strain on pot shaft. Tighten setscrew (3).

g) Turn left dial assembly full clockwise. Holding dial assembly steady at "0", insert small screwdriver in hole at center of dial assembly and turn pot shaft full clockwise, then five degrees counterclock-

wise to relieve strain on pot shaft. Tighten setscrew (3).

h) Rotate both dial assemblies making certain their range is from "0" to "9".

### REPLACEMENT PARTS LIST

#### ORDERING

The following lists specify parts available from Moog Music, Inc., Customer Service Department, 2500 Walden Avenue, Buffalo, New York 14225, (716) 681-7242. Please specify the unit name, model, serial number, part description, electrical reference designator if applicable and part number when ordering.

#### STAGE PHASER REPLACEMENT PARTS LIST

INDEX NO.	PART NUMBER	DESCRIPTION	QTY
Figure 2	997-040096-001	Stage Phaser . . . . .	
1	997-040040-001	Battery Holder Assembly, consisting of: . . . . .	1
	964-040004-001	Battery Holder . . . . .	1
	930-040044-001	Plunger . . . . .	2
	930-040043-003	Grommet . . . . .	2
2		Battery, 9 Volt, NEDA 1604 . . . . .	Ref
3	903-040036-061	Setscrew, No. 6-32 x 5/16 lg. Cup Point (Clad Plate) . . . . .	2
4	997-040041-001	Dial Assembly, Left Side, consisting of: . . . . .	1
	964-040020-001	Dial . . . . .	1
	913-040022-001	Decal, Dial, Left Side . . . . .	1
	913-040046-001	Decal, Disc . . . . .	1
5	997-040041-003	Dial Assembly, Right Side, consisting of: . . . . .	1
	964-040020-001	Dial . . . . .	1
	913-040022-003	Decal, Dial, Right Side . . . . .	1
	913-040046-001	Decal, Disc . . . . .	1
6	997-040118-001	Foot Control Assembly, consisting of: . . . . .	1
	914-040114-001	Foot Control Top . . . . .	1
	913-040395-001	Decal, Pointer . . . . .	1
	976-040117-001	Spring, Knob . . . . .	1
	964-040055-001	Knob, Foot Control . . . . .	1
7	902-040504-007	Nut, 3/8-32 . . . . .	2
8	904-040065-014	Lock Washer, 3/8 Int. . . . .	2
9	811-040039-010	Screw, Self Tapping, No. 6A x 5/8 lg . . . . .	6
10	811-040032-016	Screw, Self Tapping, No. 6A x 1 lg . . . . .	2
11	968-040009-001	End Cap, Die Cast . . . . .	2
12	997-040655-001	Hinge Assembly, consisting of: . . . . .	1
	968-040014-005	Hinge Extrusion . . . . .	1
	916-040021-001	Foot Pad . . . . .	2
	905-040045-003	Rivet, Nylon . . . . .	2
13	975-040128-001	Spring, Compression . . . . .	1
14	902-040504-007	Nut, 3/8-32 . . . . .	3
15	904-042026-001	Flat Washer, 3/8 . . . . .	3
16	902-040400-001	Nut, 1/4 . . . . .	1
17	904-040399-001	Flat Washer, 1/4 . . . . .	1
18	996-040105-001	Printed Circuit Board Assembly (Refer to Figure 3) . . . . .	1
19	997-040125-001	Push Switch Assembly, consisting of: . . . . .	1
20	902-040504-006	Hex Nut (15/32 Bushing) . . . . .	AR Ref
21	904-040049-001	Lock Washer (15/32 Bushing) Int. Tooth . . . . .	2
22	904-040091-001	Flat Washer (15/32 Bushing) . . . . .	1
23	902-041442-007	Hex Ring (15/32 Bushing) . . . . .	AR Ref

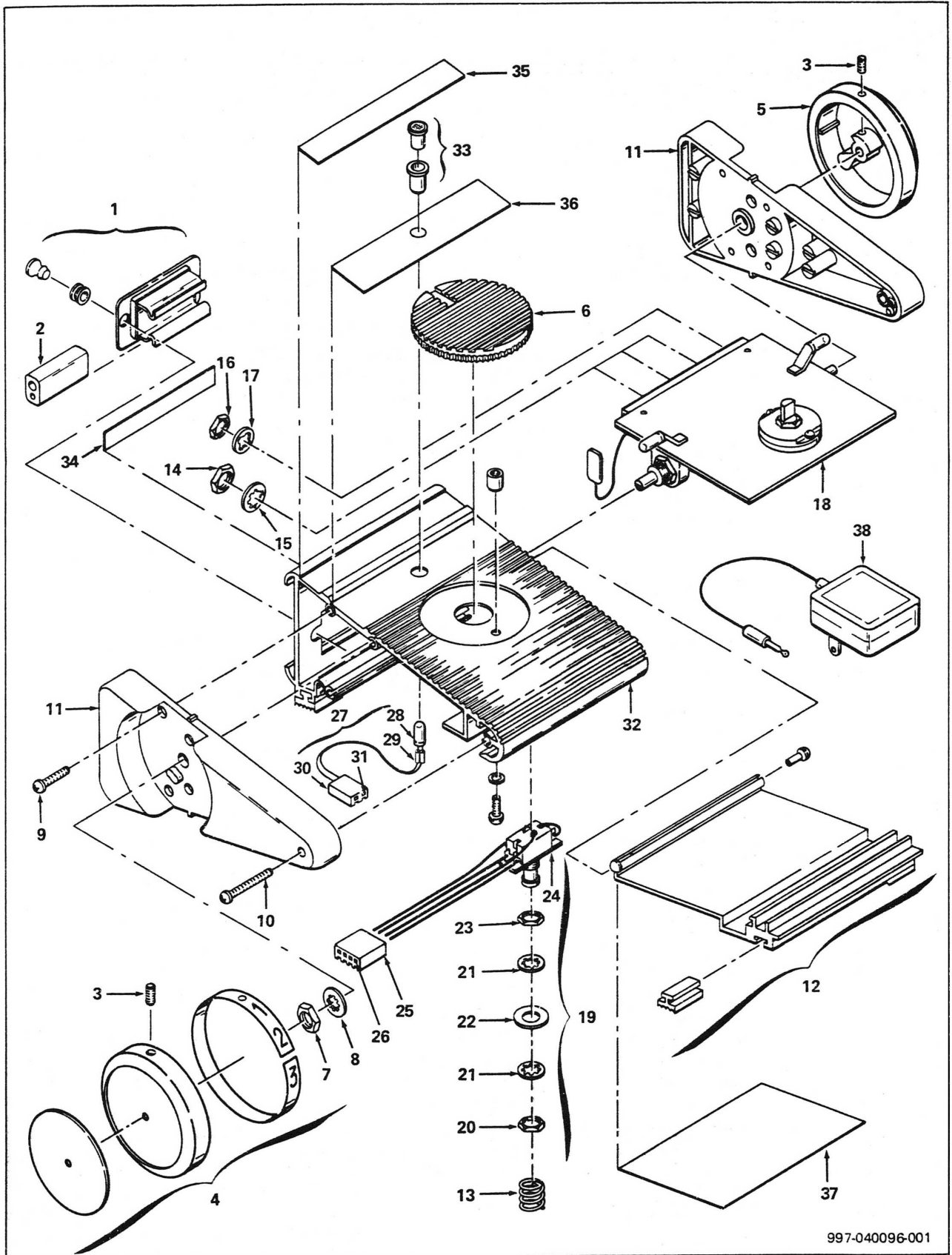

997-040096-001

FIGURE 2 MAESTRO STAGE PHASER EXPLODED VIEW

STAGE PHASER REPLACEMENT PARTS LIST (CONTINUED)

INDEX NO.	PART NUMBER	DESCRIPTION	QTY
24	960-040042-001	Push Switch, DPDT . . . . .	1
25	910-041714-004	Terminal Housing, 4 Position . . . . .	1
26	910-041720-001	Pin. . . . .	4
27	997-040101-001	LED Assembly, consisting of: . . . . .	1
28	935-040111-001	Light Emitting Diode, Red. . . . .	1
29	965-040772-004	Tubing, Shrink, Black, 1/8. . . . .	2
30	910-041714-002	Terminal Housing, 2 Position . . . . .	1
31	910-041720-001	Pin. . . . .	2
32	997-040100-001	Housing Assembly, consisting of: . . . . .	1
	968-040013-005	Housing Extrusion . . . . .	1
	916-040021-001	Foot Pad . . . . .	2
	806-045039-004	Screw, No. 6-32 x 1/4 lg. . . . .	1
	904-040495-016	Lock Washer, No. 6 . . . . .	1
	973-040508-038	Spacer, No. 6-32 x 3/16 lg. . . . .	1
		Push Switch Assembly (See 19, Figure 2) . . . . .	Ref
		Hinge Assembly (See 12, Figure 2) . . . . .	Ref
33	935-040119-001	Clear Lens/Bushing . . . . .	1
34	913-040084-001	Decal, EXT. D.C. - AXE - AMP - AUX. OUT. . . . .	1
35	913-040087-001	Decal, STAGE PHASER . . . . .	1
36	913-040090-001	Decal, BALLS - STATUS - SPEED . . . . .	1
37	913-040082-001	Instruction Label, Stage Phaser . . . . .	1
38	949-040092-001	Battery Eliminator . . . . .	1
	993-040398-001	Owners Manual . . . . .	1

PRINTED CIRCUIT BOARD ASSEMBLY REPLACEMENT PARTS LIST

INDEX NO. OR REF DESIG	PART NUMBER	DESCRIPTION	QTY
Figure 3	996-040105-001	Printed Circuit Board Assembly, consisting of: . . . . .	
1	980-040104-001	Printed Circuit Board . . . . .	1
2	967-040019-001	Angle Bracket . . . . .	1
3	905-002641-004	Tubular Rivet, Oval Head . . . . .	4
4	904-040065-001	Lock Washer, 1/4 Int. Tooth . . . . .	1
5	904-040065-014	Lock Washer, 3/8 Int. Tooth . . . . .	3
6	976-040793-001	Cable Tie, Small . . . . .	1
7	935-041601-001	Battery Clip, 9 Volt . . . . .	1
8	967-040054-001	Lamp Bracket . . . . .	2
9	965-040772-006	Tubing, Shrink, Black, 1/4. . . . .	2
10	965-040771-209	Sleeving, White, 20 Gage, 13/16 . . . . .	4
C1, C17	947-040200-103	Capacitor, Disc, 0.01 uf . . . . .	2
C2	946-041978-682	Capacitor, Polyester, 0.0068 uf . . . . .	1
C3, C5, C20, C22	946-041978-224	Capacitor, Polyester, 0.22 uf . . . . .	4
C4	947-042020-221	Capacitor, Polyester, 220 pf . . . . .	1
C6 thru C10, C19, C24, C11	946-041978-102	Capacitor, Polyester, 0.001 uf . . . . .	7
C12, C13, C14, C16, C18	946-041978-474	Capacitor, Polyester, 0.47 uf . . . . .	1
C15	945-040209-001	Capacitor, Aluminum, Electrolytic, 10 uf/25 V . . . . .	5
C21, C23	946-040231-002	Capacitor, Tant, 10 uf/25 V . . . . .	1
CR1, CR3	946-041978-332	Capacitor, Polyester, 0.0033 uf . . . . .	2
CR2	919-042019-001	Diode, Rectifier, 1N4004 . . . . .	2
IC1, IC8, IC10	919-041274-001	Diode, Zener, 9 V, 1N5240 . . . . .	1
IC2 thru IC7	991-041209-001	Integrated Circuit, SN72LO22P . . . . .	3
IC9, IC11	991-041210-001	Integrated Circuit, CA3094E . . . . .	6
	991-041089-002	Integrated Circuit, CA3080E . . . . .	2



PRINTED CIRCUIT BOARD ASSEMBLY REPLACEMENT PARTS LIST (CONTINUED)

INDEX NO. OR REF DESIG	PART NUMBER	DESCRIPTION	QTY
J1	910-041306-004	Jack, Phone, 2 Circuit, AXE .....	1
J2	910-040109-001	Jack, Phone, Minature, EXTERNAL D.C.....	1
J3, J4	910-041306-001	Jack, Phone, 1 Circuit, AMP .....	2
L1, L2	939-040108-001	Lamp .....	2
N1, N2	949-040612-001	Resistor Network, Variable, No. 1 (R10, R12, R14, R15, R17, R20), No. 2 (R19, R22, R24, R25, R27 R30) .....	2
N3	949-040613-001	Resistor Network, Fixed (R71, R75 thru R80) .....	1
P1	910-041803-006	Connector, Straight, 6 Position .....	1
Q1, Q4	991-041053-001	Transistor, Darlington, D16P1 .....	2
Q2	991-041051-001	Transistor, NPN, 2N3904 .....	1
Q3	991-041052-001	Transistor, PNP, 2N3906 .....	1
Q5A, Q5B	958-040672-001	Transistor, Matched Pair, 2N3904 and 2N3906 .....	1
Q6	991-041275-001	Transistor, E101 .....	1
R1, R13, R18, R23, R28, R33, R39, R45, R47, R73, R83, R89, R90	852-312103-001	Resistor, 10K Ohms, $\pm 5\%$ , 1/4 W .....	13
R2, R81, R86	852-312105-001	Resistor, 1 Megohm, $\pm 5\%$ , 1/4 W .....	3
R3, R37, R48	852-312102-001	Resistor, 1 K Ohms, $\pm 5\%$ , 1/4 W .....	3
R4, R62	852-312472-001	Resistor, 4.7K Ohms, $\pm 5\%$ , 1/4 W .....	2
R5, R36, R60, R61, R65, R82	852-312104-001	Resistor, 100K Ohms, $\pm 5\%$ , 1/4 W .....	6
R6, R35	852-312154-001	Resistor, 150K Ohms, $\pm 5\%$ , 1/4 W .....	2
R7	852-312623-001	Resistor, 62K Ohms, $\pm 5\%$ , 1/4 W .....	1
R8	852-312124-001	Resistor, 120K Ohms, $\pm 5\%$ , 1/4 W .....	1
R9	925-040078-001	Potentiometer, Audio, 1 Megohm, BALLS .....	1
R11, R16, R21, R26, R31	852-312751-001	Resistor, 750 Ohms, $\pm 5\%$ , 1/4 W .....	5
R29, R32, R44, R70, R85	852-312393-001	Resistor, 39K Ohms, $\pm 5\%$ , 1/4 W .....	5
R34, R59	852-312203-001	Resistor, 20K Ohms, $\pm 5\%$ , 1/4 W .....	2
R38, R67	925-040275-004	Potentiometer, 10K Ohms, CENTER and SPEED TRIM .....	2
R40	852-312272-001	Resistor, 2.7K Ohms, $\pm 5\%$ , 1/4 W .....	1
R41	852-312361-001	Resistor, 360 Ohms, $\pm 5\%$ , 1/4 W .....	1
R42	852-312513-001	Resistor, 51K Ohms, $\pm 5\%$ , 1/4 W .....	1
R43	925-040079-001	Potentiometer, Reverse Audio, 1 Megohm, SPEED .....	1
R46	852-312010-001	Resistor, 1 Ohm, $\pm 5\%$ , 1/4 W .....	1
R49, R74, R84	852-312204-001	Resistor, 200K Ohms, $\pm 5\%$ , 1/4 W .....	3
R50	852-512101-001	Resistor, 100 Ohms, $\pm 5\%$ , 1/2 W .....	1
R51, R66	852-312101-001	Resistor, 100 Ohms, $\pm 5\%$ , 1/4 W .....	2
R52	852-312364-001	Resistor, 360K Ohms, $\pm 5\%$ , 1/4 W .....	1
R53, R56	852-312473-001	Resistor, 47K Ohms, $\pm 5\%$ , 1/4 W .....	2
R54	852-312242-001	Resistor, 2.4K Ohms, $\pm 5\%$ , 1/4 W .....	1
R55	852-312123-001	Resistor, 12K Ohms, $\pm 5\%$ , 1/4 W .....	1
R57	852-312226-001	Resistor, 22 Megohms, $\pm 5\%$ , 1/4 W .....	1
R58, R63	852-312303-001	Resistor, 30K Ohms, $\pm 5\%$ , 1/4 W .....	2
R64	852-312302-001	Resistor, 3K Ohms, $\pm 5\%$ , 1/4 W .....	1
R68	852-312244-001	Resistor, 240K Ohms, $\pm 5\%$ , 1/4 W .....	1
R69	852-312114-001	Resistor, 110K Ohms, $\pm 5\%$ , 1/4 W .....	1
R72, R88	852-312152-001	Resistor, 1.5K Ohms, $\pm 5\%$ , 1/4 W .....	2
R87	852-312153-001	Resistor, 15K Ohms, $\pm 5\%$ , 1/4 W .....	1
SW1	960-040064-001	Switch, Rotary, 3P3T .....	1

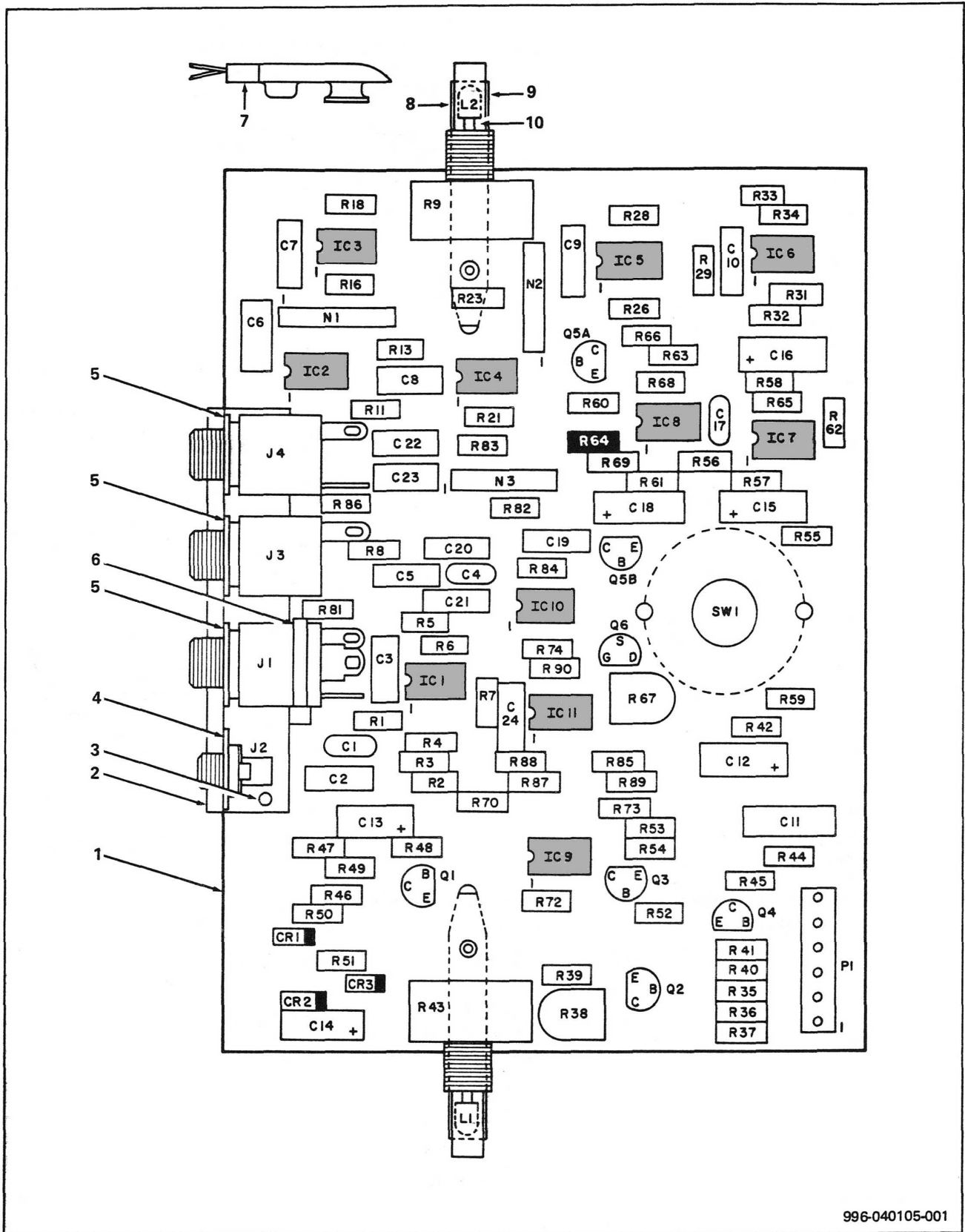
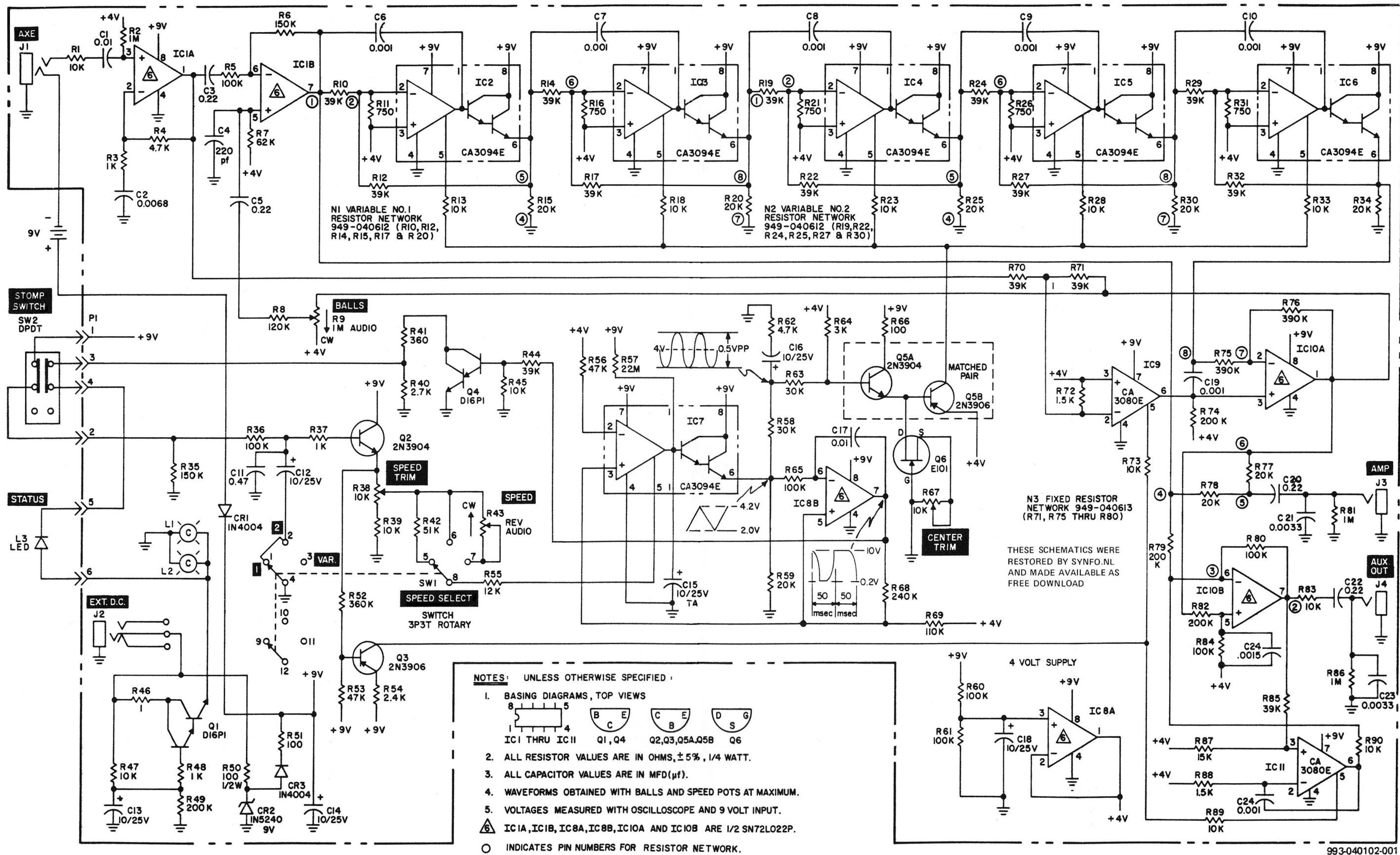

FIGURE 3 PRINTED CIRCUIT BOARD ASSEMBLY



993-040102-001

FIGURE 4. STAGE PHASER SCHEMATIC DIAGRAM