

OPERATION AND MAINTENANCE MANUAL

**DYNAMIC SIBILANCE
CONTROLLER**

MODEL 526A

orban

TABLE OF CONTENTS

SPECIFICATIONS

Section 1: DESCRIPTION: 1

Section 2: INSTALLATION: 1

 Inspection: 1
 Mounting the Chassis: 1
 Electrical:
 Input: 1
 Output: 2
 Interface: 2
 AC Power: 2

Section 3: OPERATING INSTRUCTIONS: 2

 Applicability and Limitations: 2
 Patching Into the System: 2
 Adjustment of the Operating Controls: 3
 Internal Adjustment for Extra-Noisy Tracks: 3

Section 4: MAINTENANCE: 3

 Performance Test and Alignment: 3
 Equipment Required: 3
 Power Supply: 3
 Signal-Processing Circuitry: 3
 Preventive Maintenance: 4
 Replacement of Components on Printed Circuit Boards: 4
 Troubleshooting IC Opamps: 4
 Factory Service: 5
 Shipping Instructions: 5

Section 5: CIRCUIT DESCRIPTION: 5

 Main Audio Path: 5
 Control Circuit: 5
 Level-Tracking Circuit: 6
 Level Indicator: 6
 Power Supply: 6

PARTS LIST : 7

ASSEMBLY DRAWING : 9

SCHEMATIC DIAGRAM

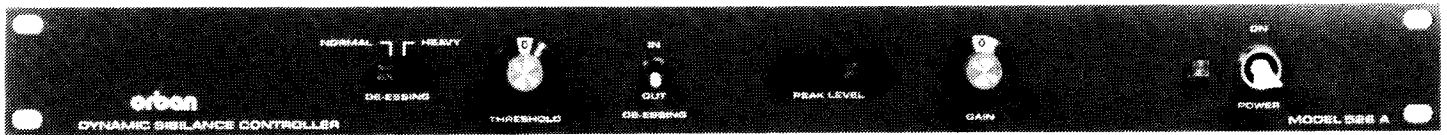

SPECIFICATIONS: 526A DYNAMIC SIBILANCE CONTROLLER

ELECTRICAL

Input: (switchable for mic or line)
Load Impedance - Mic: greater than 1K ohms, balanced bridging (for 200 ohm microphones)
- Line: 10K ohms, balanced bridging
Nominal Level: - Mic: -60 to -35dBm
- Line: -20 to +4dBm
(Feedback-type gain control optimizes overload/noise ratio for different input levels)

Output:
Source Impedance: 600 ohms, transformer balanced and floating
Nominal Level: exceeds +20dBm into 600 ohms, 20-20,000Hz

Frequency Response:
± 1dB, 20-20,000Hz (below threshold of de-essing)

Maximum Voltage Gain:
Mic: +56dB; Line: +22dB

Input Level Range for Constant De-essing:
> 15dB

Total Harmonic Distortion:
De-essing defeated: <0.1%, 30-20,000Hz @ +18dBm
De-essing in: <0.5% @ 6kHz

Noise at Output:
Less than -80dBm; -85dBm typ. (20kHz bandwidth, unity gain through line input)

Attack Time:
Approximately 1ms

Recovery Time:
Approximately 10ms

Variable Gain Element:
Junction field-effect transistor

Indicators:
De-essing: 2 element LED array
Output Level: 5 element LED array (full-wave, peak-reading, 5ms attack time)

Operating Temperature:
0-50°C

Power Requirements:
115/230 VAC ± 10%; 50/60Hz; 8 watts

PHYSICAL

Panel:
19" x 1 3/4" (48.3 x 4.4cm): 1 unit

Chassis Depth Behind Panel:
5 1/4" (13.3cm)

AC Cord:
3-wire U-ground to USA standard

Connectors:
140-type barrier strip (#5 screw). Input is parallel-wired to female XLR-type connector. A hole is punched for an XLR-type output connector (Switchcraft D3M or equal)

Weight:
Net: 4.5 lbs. (2.1 kg)
Shipping: 6 lbs. (2.7 kg)

All specifications are typical unless otherwise indicated, and are subject to change without notice.

ORBAN 526A SINGLE-CHANNEL DYNAMIC SIBILANCE CONTROLLER

OPERATION AND MAINTENANCE MANUAL

Section 1: DESCRIPTION

The Orban 526A Dynamic Sibilance Controller has been designed as a universal de-esser for the recording, broadcast, and motion picture industries. It offers electrical specifications consistent with other state-of-the-art audio signal processing equipment, extremely simple setup and operation, and dynamic characteristics which have been optimized for sibilance control. The 526A incorporates a circuit which forces the threshold of de-essing to track the average input level, permitting constant amounts of de-essing and audibly consistent results over an input level range of approximately 15dB.

Compared to its widely accepted predecessor, the three-channel 516EC, the 526A offers the following improved features:

- 1] transformer-coupled, balanced inputs and outputs;
- 2] mic and line-level inputs;
- 3] five-segment peak-reading output level indicator;
- 4] gain control;
- 5] two segment (normal and heavy) gain reduction indicator;
- 6] full RFI suppression;
- 7] improved circuit stability;
- 8] improved control-loop dynamics;
- 9] higher slewrate and lower high-frequency distortion.

De-essers have existed for years, usually as frequency-dependent sidechains in limiters or compressors. However, a compressor used as a de-esser cannot function optimally if one attempts to compress and de-ess with the same device, since optimum compression ratios, attack times, and release times are quite different for the two modes of operation. In addition, such devices are often insufficiently adjustable, and often contain simple filters whose selectivity is inadequate to provide sufficient differentiation between sibilance frequencies and the lower frequencies where most of the voice energy is concentrated. Further, these devices cannot simultaneously de-ess voice and maintain natural dynamic range because their thresholds are fixed.

It is clear that a specialized de-esser is therefore necessary to perform the sibilance control only. It is ordinarily the last piece of processing hardware in a chain which may include both an equalizer and a compressor or limiter. Both devices will tend to increase sibilance with reference to the energy of the lower-frequency vocal components; the de-esser then knocks down sibilance levels until they are once again natural-sounding and do not cause overload in recording media employing high frequency preemphasis.

It is this function which the 526A serves. When not de-essing, it acts as a high-quality amplifier. When the level in the sibilance band attempts to exceed a certain fraction of the peak input level (said fraction being adjusted by the operator with the threshold control), then the gain is automatically reduced to hold the output at this threshold level.

The 526A attacks in approximately 1ms and recovers in approximately 10ms. It can thus act on sibilance without affecting surrounding vocal sounds. Because

the entire channel gain is reduced (as opposed to de-essers which operate as program-controlled filters), any residual IM distortion which accompanies the original sibilance is reduced along with the sibilance itself.

Section 2: INSTALLATION

INSPECTION:

When the 526A is unpacked, it should be immediately inspected for shipping damage. It was in perfect electrical and mechanical condition when it was shipped from the factory. If damage has occurred, you must immediately file a claim against the carrier. We will help you if you wish.

MOUNTING THE CHASSIS:

The 526A requires 1 3/4" (1 unit) of space in a standard 19" rack. In order to achieve good visibility of the LED displays, the panel should be clearly viewable by the operator, and should not be over-lit. Locations with high AC magnetic fields should be avoided (hum may be induced in the transformers), and the 526A should not be mounted over a device producing large amounts of heat like a vacuum tube power amplifier. This could shorten component life. Ambient temperature should not exceed 45 degrees Celcius (113 degrees Fahrenheit) when the equipment is powered and operating.

The 526A will ordinarily pick up its chassis ground from the rack. It may be necessary to scrape the paint from the rack and/or the back of the 526A panel to secure a good connection. Resistance between the 526A and the rack should not exceed 1 ohm.

ELECTRICAL:

Input:

The 526A will accept either microphone or line-level inputs. A rear-panel switch determines the input mode. The inputs are both transformer-balanced, floating, and bridging.

The input is duplicated on the rear-panel barrier strip and on an XLR-3-type female microphone connector. The latter is wired: pin 3=high; pin 2=low; pin 1=chassis. All wiring should be completed in two-conductor shielded cable with the shield connected to chassis ground. Because of the fully-balanced configuration, ground loops ordinarily are not a problem. However, in general the shield should be connected at one end only, and the chassis of the various devices in the system should be connected in the usual way through the rack or through the safety ground on the AC power cord.

The microphone input provides a load impedance of approximately 1000 ohms, and should be driven by 150-250 ohm microphones. The nominal input level is adjustable from approximately -60 to -35dBm by means of the GAIN control on the front panel.

The line input is a 10K ohm balanced bridging input, and is created by inserting a balanced pad between the system input and the transformer primary. Therefore, best results are obtained if it

is driven from a true balanced source. However, little degradation will be observed if it is driven from an unbalanced source, and one side of the input is grounded.

Nominal line input levels are -20 to +8dBm. The lowest gain available (with the GAIN control fully counterclockwise) is approximately -6dB. Bear in mind that the output clips at approximately +21dBm; this translates to a maximum peak level at the input of +27dBm. Many voices have very high peak-to-average ratios; it is important not to overload the input if clipping is to be avoided.

Output:

The output is transformer-balanced and floating and can typically drive +21dBm into 600 ohms. If a balanced input is to be driven, connect the high and low sides of the 526A output to the high and low sides of the driven input in the obvious way. If an unbalanced input is to be driven, then one side of the 526A output should be connected to the circuit ground of the driven equipment. In both cases, the connection should be made in two-conductor shielded cable (Belden 8450, 8451 or equivalent) with the shield connected at one end only to chassis ground.

For best frequency response, the output should be terminated with a 620 ohm 5% 1/4 watt resistor. If this is not done, a supersonic peak will appear in the frequency response which may destabilize the 526A if high gain is used.

Interface:

Ordinarily, the 526A is employed as a patchable outboard processor, and the usual conventions apply. However, in broadcast applications, complications may arise because most broadcast consoles do not make external patch points available. In this case, the 526A's microphone preamplifier may be used to replace the mic preamp within the console. In most cases, the quality of the 526A's preamp will exceed that of the broadcast console, and it is fully suited for use as a "main microphone input" in Proof Of Performance measurements.

The simplest installation requires that the connection to the console's internal microphone preamp be broken just before the microphone key, and the output of the 526A connected in its place. Because the 526A output is transformer-coupled, little difficulty is likely to occur, although some care should be taken to avoid coupling RF into the console through long output leads from the 526A. In addition, the nominal output level of the 526A is +4dBm. This is higher than most broadcast mic preamps, and a loss pad may have to be inserted between the 526A output and the microphone key to permit operation of the mic fader in a convenient part of its range.

The case of broadcast consoles using DC control and solid-state switching is beyond the scope of this manual; each case must be independently considered.

If additional processing is desired in the mic channel, this must be placed after the 526A output if the 526A's mic preamp is to be used. This is not an ideal situation (see Section 3, "Patching"); however, good results can often be obtained regardless.

AC Power:

The 526A will operate on 115 or 230 volt, 50-60 Hz AC power. It is fitted with a "U-Ground" three-prong plug to United States standards, and users in other countries may have to use an adapter.

The green wire (connected to the long prong) is connected to the chassis, and must be connected to a good earth ground for safety. Only if absolutely necessary (if an intractable ground loop problem appears, for example) should this safety ground be lifted. Do not cut the prong from the cord; use a three-prong to two-prong adapter.

Units are ordinarily shipped strapped for 115 volt operation. If they have been modified for 230 volts, there is a warning tag on the power cord.

To restrap the power transformer, it is necessary to remove the top cover of the 526A. Restrapping instructions are found stamped on the insulating fishpaper around the power transformer. It is not necessary to touch the insulated wiring; all restrapping is done by rearranging the bare wire jumpers. Take care not to overheat the transformer terminals.

Section 3: OPERATING INSTRUCTIONS

The 526A is extremely simple to operate. However, good results can only be achieved if the device's purpose and limitations are well-understood.

APPLICABILITY AND LIMITATIONS:

The 526A is designed to de-ess voice tracks only. Voice mixed with music or other sounds will give unpredictable results, because the 526A control circuitry may mistake strong high frequency components in other program material for sibilance, and cause "ducking" or "pumping". In addition, the 526A uses frequencies of 6kHz and above to control its action. Therefore, the minimum bandwidth required from the source material is approximately 8kHz for successful operation.

PATCHING INTO THE SYSTEM:

In most professional audio applications the 526A will be used in its line input mode, and will be patched into a recording or mixing console. In general, it should be the last processor in the chain before the recording device. Equalization and compression/limiting should be applied before the 526A. This way, the 526A "knows" the amount of added sibilance induced by the other processing, and can predictably control it to the level desired by the operator. If a compressor or equalizer is located after the 526A, then the controlled sibilance levels at the 526A's output could be disturbed by the additional processing.

In broadcast applications, the 526A will usually be operated in its mic input mode, and will replace the microphone preamp in the broadcast console. If further processing is done (such as equalization or mic channel compression), it may be necessary to perform it after the 526A. This will often work if the 526A is carefully set up. However, the performance of the overall processing chain should

be carefully monitored to make sure that no unexpected effects occur.

PERFORMANCE TEST AND ALIGNMENT:
[REFER TO THE ASSEMBLY DRAWING AND SCHEMATIC AT THE BACK OF THIS MANUAL.]

ADJUSTMENT OF THE OPERATING CONTROLS:

The 526A has only two operating controls: THRESHOLD and GAIN. In addition, there are two switches: DE-ESSING IN/OUT and POWER ON/OFF. Operation is extremely simple:

- 1] Apply power to the unit with the POWER switch.
- 2] Adjust the GAIN control until the LED PEAK LEVEL indicator is peaking in the green. The red indicates that clipping is dangerously imminent. The five LED's correspond approximately to the following peak output levels (normalized to equivalent RMS levels): 1(red): +18dBm; 2(amber): +16dBm; 3(green): +14dBm; 4(green): +10dBm; 5(green): +4dBm. The integration time of the peak detector is approximately 5mS, making it about twice as fast as a standard BBC Peak Programme Meter.
- 3] Turn the DE-ESSING switch ON, and adjust the THRESHOLD control until sibilance levels sound natural. De-essing is indicated by illumination of the NORMAL GAIN REDUCTION LED. If the THRESHOLD control is advanced too far clockwise such that excessive de-essing occurs, the unit may start to act on low-frequency vocal material also. It will seriously distort such material (because of the very fast recovery time), so it is important not to try to obtain more de-essing than that which simply sounds natural. (A special non-linear control-voltage smoothing circuit assures that the fast recovery time will not distort sibilance.) In most cases, the HEAVY GAIN REDUCTION LED will warn when excessive de-essing is occurring, and that there is danger of introducing distortion.
- 4] The DE-ESSING switch affects the control loop only. Therefore, it may be freely operated in the middle of program material without clicks, pops, or gain changes.

INTERNAL ADJUSTMENT FOR EXTRA-NOISY TRACKS:

The level-tracking circuitry cannot be permitted to track down to extremely low levels, or noise could be mistaken for sibilance, thus forcing high gain reduction during pauses. The lower tracking limit is adjustable by means of an internal trimmer pot, R37. If extremely hissy tracks are being processed, it may be necessary to readjust this trimmer to accommodate the added noise. If the 526A audibly "gulps" during pauses, this trimmer should be readjusted. Because this situation is so rare, the control was not brought to the front panel.

To readjust, remove the top cover. Find R37 on the assembly drawing at the back of this manual. While listening to the problem program material, adjust R37 counterclockwise until the "gulping" goes away, and go a bit further for safety.

Unless this program material is typical in your application, you will probably want to readjust R37 to its standard mid-setting after you are finished with the noisy track. If left in its realigned setting, R37 may unnecessarily limit the range of input level which the 526A can process with constant de-essing characteristics.

Equipment Required:

- (1) VTVM or DVM
- (2) oscilloscope
- (3) low-distortion oscillator/harmonic distortion meter
(Sound Technology 1700B/1710B; H-P 339)
- (4) 20-20kHz bandpass filter with 18dB/octave maximally flat (Butterworth) skirts

Power Supply:

- 1] Using the voltmeter, check the unregulated DC supply. Measure the voltage from circuit ground to both the (+) and (-) supplies. This should range between 18 and 26 volts DC, depending on line voltage and load.
- 2] Measure both regulated 15 volt supplies to circuit ground. Both supplies should be between 14.25 and 15.75 volts. If either supply exceeds 15.75, it implies that its associated regulator IC is defective. If either supply is below 14.25 volts DC, refer to the CIRCUIT DESCRIPTION section for possible causes.

3] Using the AC VTVM section of the THD meter, measure the total ripple and noise on each power bus. This should not exceed 1 mV RMS in the 20-20K Hz band.

Signal Processing Circuitry:

1] Setup: Remove the 526A top cover to access the alignment trimmers. Load the 526A output with a 520 ohm 1/4 watt 5% carbon resistor. Connect the output of the low-distortion oscillator to the 526A input. Adjust the 526A rear-panel MIC/LINE switch to LINE. Connect the 526A output to the input of the THD analyzer. Connect the THD analyzer to the oscilloscope in the usual way in order to observe the distortion residual and to check for oscillations or unusual waveforms.

2] FET Bias Adjust: Apply power to all equipment. Turn the 526A DE-ESSING switch IN. Adjust R41 fully clockwise. Apply +10dBm @20kHz to the 526A input and verify that the 526A NORMAL GAIN REDUCTION LED lights. Adjust R41 fully counterclockwise. Turn the 526A DE-ESSING switch off, and slowly turn R41 counterclockwise until no further output level increase is observed. Leave R41 at this position.

3] Headroom: Apply +10dBm @1kHz to the 526A input and adjust the 526A GAIN control to obtain +20dBm out. Make sure that the waveform is unclipped.

4] Output Meter: Reduce the 526A GAIN control until +18dBm is observed at the 526A output. Verify that all five LED's on the PEAK OUTPUT meter are illuminated, and that the red LED goes off when the output level is reduced below approximately +18dBm.

5] 1kHz THD: Now measure the THD. It should not exceed 0.1%.

6] 50Hz Frequency Response/THD: Reduce the oscillator frequency to 50Hz. Be sure the oscillator is still putting out +10dBm. Verify that the output level of the 526A is between +17 and

+19dBm. Measure the THD, and make sure it does not exceed 0.2%.

7] 20kHz Frequency Response/THD: Increase the oscillator frequency to 20kHz. Be sure that the oscillator is still putting out +10dBm. Verify that the output level of the 526A is between +17 and +19 dBm. Measure the THD, and make sure that it does not exceed 0.1%. Turn the 526A DE-ESSING switch ON, and verify that the NORMAL GAIN REDUCTION LED lights.

8] THD in Gain Reduction/THD Null: Switch the 526A DE-ESSING switch IN. Adjust the 526A THRESHOLD control to "0" (full counterclockwise). The output level should go down to approximately +9dBm. Measure the THD and adjust R12 (DISTORTION NULL) to null it. After null, verify that it does not exceed 0.5%.

9] Control Loop Operation: Vary the setting of the 526A THRESHOLD control and observe that the output level changes accordingly. If the HEAVY GAIN REDUCTION LED is on, you are close to maximum available gain reduction and further adjustment of the THRESHOLD control will not produce further decreases in output level.

10] Input Level Tracking: Set the 526A THRESHOLD control at "5.0". Reduce the input level to the 526A to -10dBm. The output level should drop approximately 20dB.

11] Non-linear Recovery Time Circuit, Level Tracking: Apply a 100Hz +10dBm signal to the 526A input. Trigger the scope from the oscillator output, and observe the output of IC6A. The waveform should be a DC level equal to 4 times the peak value of the 100Hz output of IC2. There should be a large notch on top of the DC, synchronized to the 100Hz input. Now switch the oscillator to 500Hz. There should be no notch, only a slight sawtooth riding on the DC component. This tests the operation of the circuitry associated with IC5.

12] Noise: Apply 1kHz @+10dBm to the 526A input. Adjust the 526A GAIN control until +10dBm is observed at the output. Remove the oscillator and place a 620 ohm resistor across the 526A input. Measure the 526A output noise through the 20-20k Hz bandpass filter and verify that it does not exceed -80dBm.

13] Place R37 (LIMITING TRIM) in the center of its rotation.

THIS CONCLUDES THE PERFORMANCE TEST AND ALIGNMENT.

PREVENTIVE MAINTENANCE:

The front panel may be cleaned with a mild household detergent. Stronger solvents should be used with great caution, as they may damage the paint, the silk-screened lettering, or the plastic control knobs. The interior of the 526A should be kept free of dust and dirt, since dirt buildup inside the chassis can cause loss of cooling and can also cause high-resistance short-circuits if the dirt absorbs moisture from the air. It is particularly important in a dusty or humid environment that the covers be periodically removed and the interior of the chassis cleaned.

REPLACEMENT OF COMPONENTS ON PRINTED CIRCUIT BOARDS:

It is important to use the correct technique for replacing components mounted on PC boards. Failure

to do so will result in possible circuit damage and/or intermittent problems. Fortunately, the 526A De-Esser uses an easily repairable single-sided PC board.

Use the following technique to replace a component:

1] Use a 30 watt soldering iron to melt the solder on the solder (underneath) side of the PC board. Do not use a soldering gun or a high-wattage iron! As soon as the solder is molten, vacuum it away with a spring-actuated desoldering tool like the Edsyn "Soldapullit". AVOID OVERHEATING THE BOARD; overheating will almost surely damage the board by causing the conductive foil to separate from the board base. Use a pair of fine needle-nose pliers to wiggle the lead horizontally until it can be observed to move freely in the hole.

2] Repeat step (1) until each lead to be removed has been cleared of solder and freed.

3] Now lift the component out.

4] Bend the leads of the replacement component until it will fit easily into the appropriate PC board holes. Using a good brand of rosin-core solder, solder each lead to the bottom side of the board with a 30 watt soldering iron. Make sure that the joint is smooth and shiny. If no damage has been done to the plated-through hole, soldering of the topside pad is not necessary. However, if the removal procedure did not progress smoothly, it would be prudent to solder each lead at the topside as well in order to avoid potential intermittent problems.

5] Cut each lead of the replacement component close to the solder (underneath) side of the PC board with a pair of diagonal cutters.

6] Remove all residual flux with a cotton swab moistened with a solvent like 1,1,1 trichloroethane, naphtha, or 99% isopropyl alcohol. The first two solvents are usually available in supermarkets under the brand name "Energine" fire-proof spot remover and regular spot remover, respectively. The alcohol, which is less effective, is usually available in drug stores. Rubbing alcohol is highly diluted with water and is ineffective.

It is good policy to make sure that this defluxing operation has actually removed the flux and has not just smeared it so that it is less visible. While most rosin fluxes are not corrosive, they can slowly absorb moisture and become sufficiently conductive to cause progressive deterioration of performance.

TROUBLESHOOTING IC OPAMPS:

IC opamps are usually operated such that the characteristics of their associated circuits are essentially independent of IC characteristics and dependent only on external feedback components. The feedback forces the voltage at the (-) input terminal to be extremely close to the voltage at the (+) input terminal. Therefore, if the technician measures more than a few millivolts between these two terminals, the IC is probably bad.

Exceptions are IC's used without feedback (as comparators) and IC's whose outputs have been saturated due to excessive input voltage because of a defect in an earlier stage. Also, be sure that the voltmeter is not interacting with these

sensitive points and affecting the measured voltage. However, if an IC's (+) input is more positive than its (-) input, yet the output of the IC is sitting at -14 volts, this almost certainly indicates that it is bad. The same holds if the above polarities are reversed.

A defective opamp may appear to work, yet it may have extreme temperature sensitivity. If parameters appear to drift excessively, freeze-spray may aid in diagnosing the problem. Freeze-spray is also invaluable in tracking down intermittent problems. But, use sparingly, because it can cause resistive short circuits due to moisture condensation on cold surfaces.

FACTORY SERVICE:

Please refer to the terms of your Orban Associates One-Year Standard Warranty, which extends to the first end-user. This warranty was included with the 526A but not bound with this manual. After expiration of the warranty, a reasonable charge will be made for parts, labor, and packing if you choose to use the factory service facility. In all cases, transportation charges (which are usually quite nominal) shall be borne by the customer.

After a formal Return Authorization number is obtained from the factory, units should be shipped to the following address:

SERVICE MANAGER
ORBAN ASSOCIATES, INC.
645 BRYANT STREET
SAN FRANCISCO, CALIFORNIA 94107

YOUR RETURN AUTHORIZATION NUMBER MUST BE SHOWN ON THE LABEL, OR THE PACKAGE WILL NOT BE ACCEPTED!

PHONE (415) 957-1067
OR TELEX 17-1480

SHIPPING INSTRUCTIONS:

If the original packing material is available, it should be used. Otherwise, a carton of at least 200 pounds bursting test and no smaller than 22" x 9" x 6" should be employed.

The 526A De-Esser should be packed so that there is at least 1-1/2" of packing material protecting every point. A plastic wrap around the chassis will protect the finish. Cushioning material such as Air-Cap, Bubble-Pak, foam "popcorn", or fibre blankets are acceptable. Folded newspaper is not suitable. Blanket-type materials should be tightly wrapped around the 526A De-Esser and taped in place to prevent the unit from shifting out of its packing and contacting the walls of the carton.

The carton should be packed evenly and fully with the packing material filling all voids such that the unit cannot shift in the carton. Test for this by closing but not sealing the carton and shaking vigorously. If the unit can be felt or heard to move, use more packing.

The carton should be well-sealed with 3" reinforced sealing tape applied across the top and bottom of the carton in an "H" pattern. Narrower or parcel-post type tapes will not stand the stresses applied to commercial shipments.

The package should be marked with the name of the shipper, and the words in red: DELICATE

INSTRUMENTS, FRAGILE!. Even so, the freight people will throw the box around as if it were filled with junk. The survival of the unit depends almost solely on the care taken in packing!

Section 5: CIRCUIT DESCRIPTION (WITH TROUBLESHOOTING HINTS):

Main Audio Path:

The signal enters the 526A in balanced form, and passes through RFI filter C1, C2 plus ferrite beads. If the MIC position of the rear-panel INPUT MODE switch is selected, the input is applied directly to the primary of T1, a high-quality shielded transformer with 17dB voltage gain. If the LINE position of the switch is selected, the signal is passed through balanced bridging pad R1, R2, R3 whose loaded voltage loss is -36dB.

The secondary of T1 is loaded by 68K, which assures flat frequency response without significantly compromising the bridging characteristics of the transformer. This resistor reflects back to T1's primary as approximately 1.1K.

The secondary voltage of T1 is amplified by IC1, an ultra-low-noise opamp operated in a non-inverting configuration. Its voltage gain is adjustable by R6 (GAIN) from a minimum of 12dB to a maximum of 40dB.

The output of IC1 is connected to the level tracking circuitry (to be described below), and to voltage-controlled attenuator R7, R8, Q1. R7, R8 reduce the signal to the level where it is not significantly distorted by the nonlinear characteristics of Q1. Q1 is ordinarily biased off by means of a negative voltage applied to its gate through R11, R38, R41, CR3 when no de-essing is taking place. Under this condition, it does not affect the circuit, which operates as a conventional high-quality amplifier. However, when the voltage on Q1's gate is made more positive, the resistance between Q1's gate and source begins to decrease, thus introducing attenuation. The minimum gate/source resistance occurs when Q1's gate is at ground; this corresponds to maximum attenuation.

The relatively low level across Q1 is amplified to line level by low-noise opamp IC2, operating with 35dB non-inverting gain. IC2 is capable of driving 600 ohm loads without current boosters; it therefore drives the primary of 1:1 output transformer T2 directly. In addition, feedback is taken from the output of IC2 to the gate of Q1 through compensated attenuator R11, R12, C10, C7. This introduces one-half the signal present at Q1's drain to its gate, which compensates for asymmetrical operation of Q1 and which nulls even-order distortion.

Control Circuit:

The output of IC2 is passed to the control module, which contains frequency-selective elements and an error comparator. The frequency-selective elements cause the sensitivity of the error detector to be progressively decreased below 6kHz. Thus the error detector is maximally sensitive to sibilance frequencies, and discriminates against lower frequency vocal energy.

The output of the module is in the form of current pulses which are integrated by delayed-release integrator CR1, CR2, CR3, C7, C8, R38. C7 and C8 are charged through CR1 and CR2 to approximately equal voltages when gain reduction is demanded by the control module. However, recovery from gain reduction can only occur by discharging C8 through R38.

Therefore C7 holds its charge until C8 has been sufficiently discharged to overcome the turn-on potential of CR3. This provides effective non-linear smoothing of the control voltage developed on C7, and introduced to Q1's gate through R11.

Gain reduction is detected by IC7A,B operating as a pair of comparators. Gain reduction is indicated by a voltage drop across recovery resistor R38. This is sensed by the two halves of IC7. In order to hold IC7B (NORMAL GAIN REDUCTION) off under no gain reduction conditions, its (-) input is biased slightly more positive than the R41 side of R38 by R42, R43. The (-) input of IC7A (HEAVY GAIN REDUCTION) is biased close to ground. When IC7A turns on, it indicates that almost all of the potential gain reduction available has been used.

Level-Tracking Circuit:

The level-tracking circuit consists of IC5, IC6, and associated components. It is designed to track the peak value of the low-frequency components of the input to the de-esser, and to modify the threshold of the error comparator inside the control module. The de-essing thus becomes a constant fraction of the input level, rather than having a fixed threshold.

The input signal is lowpass filtered at 6dB/octave by R22, R23, C12. The filter is down 3dB at 2kHz. The filter's output is positive peak-detected by IC5A, CR8, R31, and hold capacitor C14.

IC5B and associated circuitry form a non-linear recovery circuit which permits the level detector to follow falling signal levels very quickly (within approximately 5ms), yet to avoid unacceptable control voltage ripple which would occur if a simple recovery resistor were used to obtain this very fast recovery time.

There are two recovery resistors: R30 which supplies a slow recovery, and R29 which is switched on and off by Q2, and which supplies fast recovery when Q2 is on. (Q2 is on when its gate is grounded and off when its gate is more negative than -10 volts.)

IC5B, R24, R25, R26, R27, C13, CR7 form a retriggerable monostable. Each pulse which charges hold capacitor C14 through CR8 also charges C13 through CR7. Because C13 is 100 times smaller than C14, it is usually completely charged (to almost the +15 volt level) each time a charging pulse occurs. This holds the output of IC5B low and keeps Q2 off (through CR9 and R28), thus yielding slow recovery.

Each time a charging pulse ends, C13 begins to discharge through R24 towards -15 volts. As long as charging pulses continue to come through CR7, C13 will be recharged and Q2 will stay off. However, if there are no charging pulses for more than approximately 5ms, C13 will discharge below the reference voltage created by voltage divider R25, R26 (-10 volts), and IC5B will switch high, thus turning Q2 on and creating fast release. Clean switching is assured by hysteresis through R27.

Thus in the presence of signal, slow release occurs. If signal is absent for more than 5ms, fast release occurs.

The output of C14 is buffered by non-inverting gain-of-4 amplifier IC6A, which drives the THRESHOLD control R34. This scales the threshold voltage applied to the control module (pin E12), thus determining whether error pulses will be developed only with large amounts of high-frequency energy, or with smaller amounts.

R34 is buffered by a voltage follower/limiter which determines how far towards ground the reference voltage is permitted to go. If the reference voltage goes too far towards ground, then the control module could be activated on small undesired signals like tape hiss. CR11 permits the threshold line to the control module to be driven as far positive as the (+) input of IC6B is driven, thus acting like a simple unity-gain buffer amplifier. However, if the voltage on IC6B's (+) input goes less positive than the voltage formed by voltage divider R36, R37, then CR11 turns off, and the R36, R37 divider determines the voltage applied to the threshold line. This voltage is adjusted by R37 (a trimmer), and may be field-readjusted to accommodate unusually noisy program material.

Level Indicator:

The output of IC2 is full-wave precision-rectified by IC3A, R13, R14, R15, CR4, CR5. The rectified output is applied to peak detector IC3B, CR6, C11, R16. The gain of the precision rectifier is chosen so that +18dBm (equivalent RMS voltage) at the precision rectifier's input produces 1 volt at C11. IC4 contains five comparators, a reference voltage divider, and a regulator, and is a complete display-driver subsystem. Its input is pin 8. The sensitivity of IC4 is scaled so that at 0.2 volt increments each comparator in turn switches on; all five comparators are on at 1.0 volts (equivalent to +18dBm at IC2's output). Each comparator output drives its own LED.

Power Supply:

Unregulated voltage is supplied by a pair of full-wave diode rectifiers CR12,14, CR13,15 operating into a pair of energy storage capacitors C15, C16. The power transformer T3 is strappable for either 115 or 230 volt operation; the two sections of the primary of paralleled for 115 volt operation and connected in series for 230 volt operation.

The nominal unregulated voltage is +22 volts DC at normal line voltage, although this can be expected to vary widely. Regulator dropout will occur if the unregulated voltage falls below about +17.8 volts.

Regulated voltages are supplied by a pair of overrated 500mA "three terminal" IC regulators VR1, VR2. Because they are operated conservatively, they can be expected to be quite reliable. Therefore, before replacing VR1 or VR2, check to see whether other faults in the circuitry have caused excessive current demand which may be causing the regulators to go into either current-limiting or thermal shutdown, their two built-in protective modes. If it becomes necessary to replace either regulator, be sure to replace the clip-on heat sinks.

The outputs from VR1, VR2 are frequency-compensated at their outputs by C17, C18 to prevent high frequency oscillations. If C17 or C18 is ever replaced, be sure to use low-inductance aluminum electrolytics. Tantalums can fail because circuit impedance is too low and avalanche breakdown can occur. High-inductance aluminums can fail to prevent the regulators from oscillating (VR2 is most critical).

CR16, CR17 are connected across the supplies in reverse polarity, and protect the rest of the circuitry from a fault condition which might cause a reverse-polarity voltage on either bus. C19-22 are small ceramics distributed around the PC board to prevent oscillation of the circuit IC's due to coupling through the power supply lead inductance.

PART LISTINGS

30405-000 ASY MOTHERBOARD, 526A

REF. DES.	PART #	DESCRIPTION
C003	21303-633	CAP TANTALUM, 10%, 10V, 33 MFD
C004	21303-633	CAP TANTALUM, 10%, 10V, 33 MFD
C007	21401-410	CAP POLYESTER, RAD, 100V, 10%, .1 MFD
C008	21401-410	CAP POLYESTER, RAD, 100V, 10%, .1 MFD
C009	21207-647	CAP ALUM, RAD 35V 47 MFD
C010	21024-182	CAP MICA, 5%, 500V, CD19 820 PF
C011	21307-547	CAP TANTALUM, 10%, 35V, 4.7 MFD
C012	21401-233	CAP POLYESTER, RAD, 100V, 10%, .0033 MFD
C013	21401-310	CAP POLYESTER, RAD, 100V, 10%, .01 MFD
C014	21307-510	CAP TANTALUM, 10%, 35V, 1 MFD
C015	21224-747	CAP ALUM, AXIAL 40V 470 MFD
C016	21224-747	CAP ALUM, AXIAL 40V 470 MFD
C017	21206-615	CAP ALUM, RAD 25V 15 MFD
C018	21206-615	CAP ALUM, RAD 25V 15 MFD
C019	21020-022	CAP MICA, 5%, 500V, CD15 22 PF
C020	21106-350	CAP CERAMIC, 20%, 25V, .05 MFD
C021	21106-350	CAP CERAMIC, 20%, 25V, .05 MFD
C022	21106-350	CAP CERAMIC, 20%, 25V, .05 MFD
C023	21106-350	CAP CERAMIC, 20%, 25V, .05 MFD
C024	21106-350	CAP CERAMIC, 20%, 25V, .05 MFD
C025	21106-350	CAP CERAMIC, 20%, 25V, .05 MFD
C026	21106-350	CAP CERAMIC, 20%, 25V, .05 MFD
C027	21106-350	CAP CERAMIC, 20%, 25V, .05 MFD
C028	21106-350	CAP CERAMIC, 20%, 25V, .05 MFD
C029	21106-350	CAP CERAMIC, 20%, 25V, .05 MFD
C030	21106-350	CAP CERAMIC, 20%, 25V, .05 MFD
C031	21106-350	CAP CERAMIC, 20%, 25V, .05 MFD
CR009	22101-000	DIO SIGNAL, FAIRCHILD 1N4148
CR010	22101-000	DIO SIGNAL, FAIRCHILD 1N4148
CR011	22101-000	DIO SIGNAL, FAIRCHILD 1N4148
CR012	22101-000	DIO SIGNAL, FAIRCHILD 1N4148
CR013	22101-000	DIO SIGNAL, FAIRCHILD 1N4148
CR014	22101-000	DIO SIGNAL, FAIRCHILD 1N4148
CR015	22101-000	DIO SIGNAL, FAIRCHILD 1N4148
CR016	22101-000	DIO SIGNAL, FAIRCHILD 1N4148
CR017	22101-000	DIO SIGNAL, FAIRCHILD 1N4148
CR018	22101-000	DIO SIGNAL, FAIRCHILD 1N4148
CR019	22201-400	DIO RECTIFIER, 1A, MOTOROLA 1N4004
CR020	22201-400	DIO RECTIFIER, 1A, MOTOROLA 1N4004
CR021	22201-400	DIO RECTIFIER, 1A, MOTOROLA 1N4004
CR022	22201-400	DIO RECTIFIER, 1A, MOTOROLA 1N4004
CR023	22201-400	DIO RECTIFIER, 1A, MOTOROLA 1N4004
CR024	22201-400	DIO RECTIFIER, 1A, MOTOROLA 1N4004
IC001	24014-102	IC LIN, SINGLE OPAMP, SIGNETICS NE5534T
IC002	24014-102	IC LIN, SINGLE OPAMP, SIGNETICS NE5534T
IC003	24202-102	IC LIN, DUAL OPAMP, RAYTHEON 4558T
IC004	24704-000	IC SPECIAL FUNCTION, T.I. TL489
IC005	24206-202	IC LIN, DUAL OPAMP, T.I. TL072
IC006	24206-202	IC LIN, DUAL OPAMP, T.I. TL072
IC007	24203-201	IC LIN, MULT OPAMP, MOTOROLA MC1458
Q001	23403-201	TRA FET, NATIONAL J111
Q002	23403-201	TRA FET, NATIONAL J111
Q003	23202-101	TRA SIG, NPN, FAIRCHILD 2N4400
Q004	23202-101	TRA SIG, NPN, FAIRCHILD 2N4400

REFERENCE DESIGNATOR LISTING

30405-000 ASY MOTHERBOARD, 526A

REF. DES.	PART #	DESCRIPTION
R004	20001-211	RES CF, 1/4W, 5% 1.1K
R005	20001-233	RES CF, 1/4W, 5% 3.3K
R007	20001-268	RES CF, 1/4W, 5% 6.8K
R008	20001-112	RES CF, 1/4W, 5% 120 OHM
R009	20001-210	RES CF, 1/4W, 5% 1.0K
R010	20001-356	RES CF, 1/4W, 5% 56K
R011	20001-218	RES CF, 1/4W, 5% 1.8K
R012	20501-447	POT TRIM, MEPCO E086BD/470K
R013	20042-866	RES MF, 1/8W, 1% 86.6K
R014	20042-100	RES MF, 1/8W, 1% 10.0K
R015	20042-768	RES MF, 1/8W, 1% 76.8K
R016	20001-533	RES CF, 1/4W, 5% 3.3 MEG
R017	20014-210	RES CC, 1/2W, 5% 1K
R018	20014-210	RES CC, 1/2W, 5% 1K
R019	20014-210	RES CC, 1/2W, 5% 1K
R020	20014-210	RES CC, 1/2W, 5% 1K
R021	20014-210	RES CC, 1/2W, 5% 1K
R022	20001-347	RES CF, 1/4W, 5% 47K
R023	20001-347	RES CF, 1/4W, 5% 47K
R024	20001-439	RES CF, 1/4W, 5% 390K
R025	20001-382	RES CF, 1/4W, 5% 82K
R026	20001-339	RES CF, 1/4W, 5% 39K
R027	20011-612	RES CC, 1/4W, 5% 12 MEG
R028	20001-410	RES CF, 1/4W, 5% 100K
R029	20001-310	RES CF, 1/4W, 5% 10K
R030	20001-510	RES CF, 1/4W, 5% 1.0 MEG
R031	20001-033	RES CF, 1/4W, 5% 33 OHM
R032	20001-310	RES CF, 1/4W, 5% 10K
R033	20001-233	RES CF, 1/4W, 5% 3.3K
R035	20001-147	RES CF, 1/4W, 5% 470 OHM
R036	20001-368	RES CF, 1/4W, 5% 68K
R037	20501-147	POT TRIM, MEPCO E086BD/470 OHM
R038	20001-327	RES CF, 1/4W, 5% 27K
R039	20001-410	RES CF, 1/4W, 5% 100K
R040	20001-351	RES CF, 1/4W, 5% 51K
R041	20510-250	POT TRIM, CERMET, 1T, BECKMAN 72PR5K
R042	20001-410	RES CF, 1/4W, 5% 100K
R043	20001-547	RES CF, 1/4W, 5% 4.7 MEG
R044	20001-147	RES CF, 1/4W, 5% 470 OHM
R045	20014-210	RES CC, 1/2W, 5% 1K
R046	20001-368	RES CF, 1/4W, 5% 68K
T001	29107-001	XFR INPUT, BEYER BU351-007.004
VR001	24304-401	IC P.S. REGULATOR, FAIRCHILD 78M15UC
VR002	24303-401	IC P.S. REGULATOR, FAIRCHILD 79M15AUC

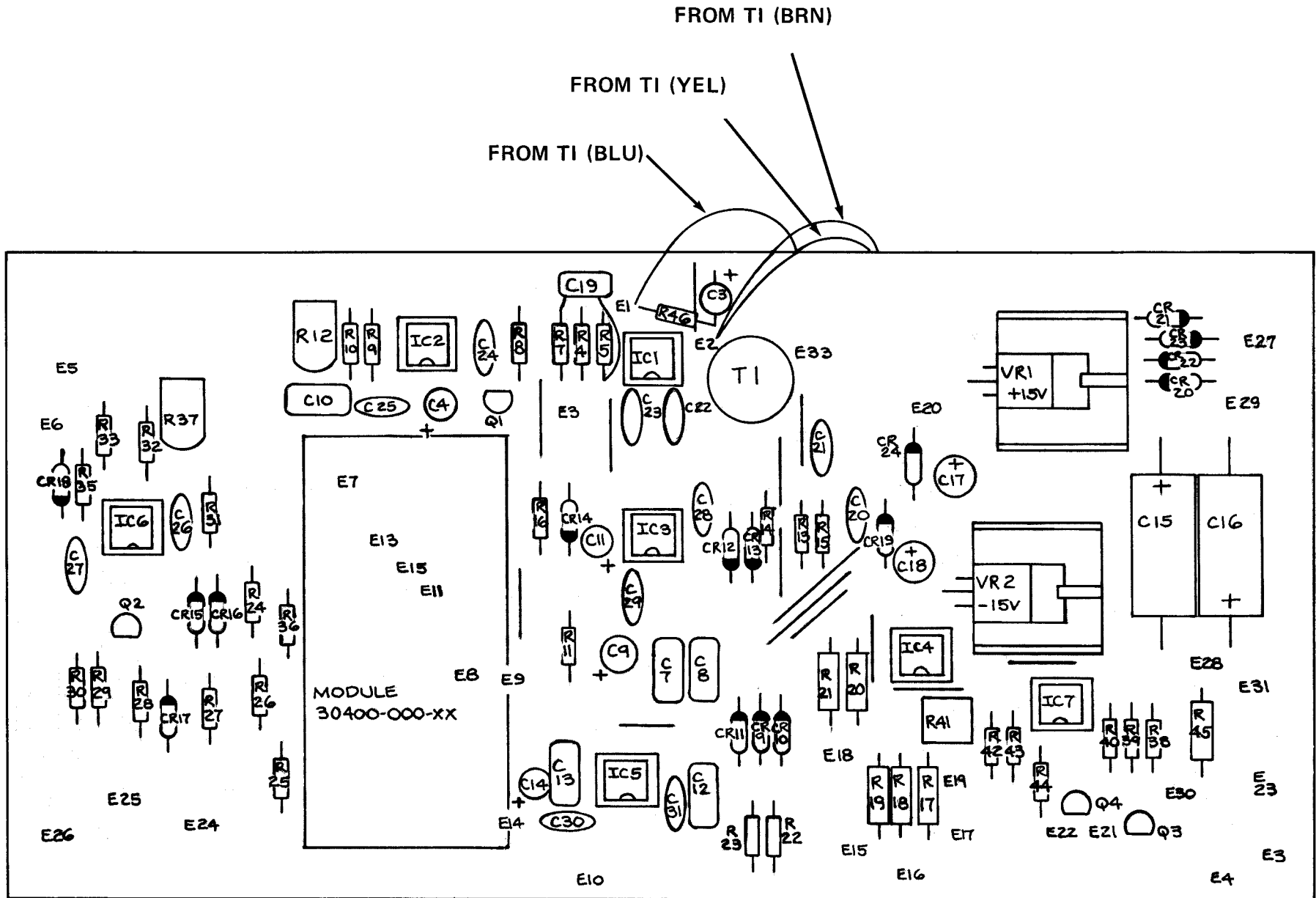

COMPONENT SIDE

orban	Orban Associates Inc.
	TITLE: ASSY, PCB, 526-A DYNAMIC SIBILANCE CONTROLLER

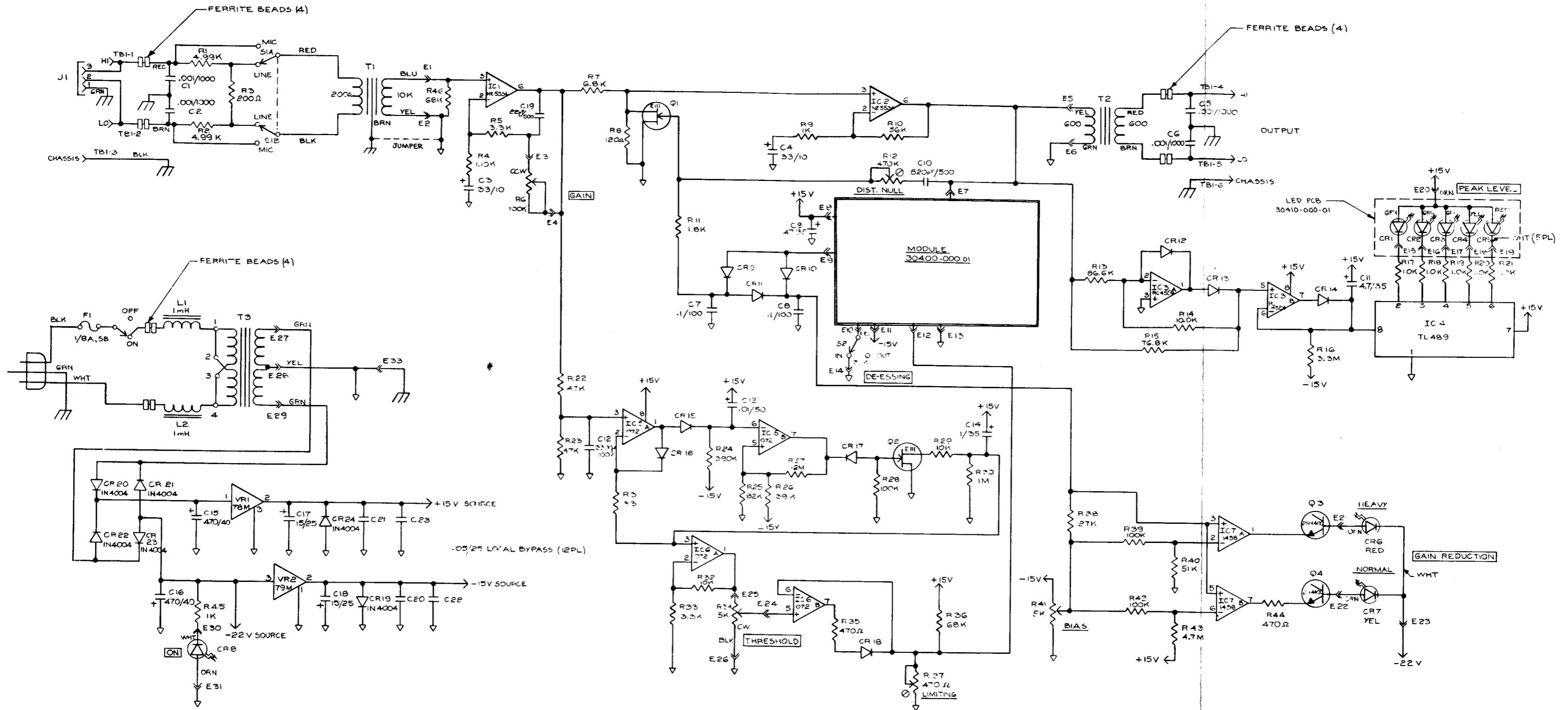

POWER PIN TABLE

IC. NO.	+15	-15	-22	GND
5534-A	7	4	NC	NC
4558	8	4	NC	3
TL489	7	NC	NC	1
TL072	8	4	NC	NC
1458	NC	NC	4	8
3080	7	4	NC	NC

3. REF. DOCUMENTS: A55X, MOT-PCBBOARD: 30405-000-XX

2. ALL CAPACITORS IN μ F.

1. ALL DIODES ARE IN4148.

NOTES: UNLESS OTHERWISE SPECIFIED.

©1979 ORBAN ASSOCIATES INC., SAN FRANCISCO, CA.

60033-000-04

orban Orban Associates Inc.
 TITLE: SCHEMATIC, DSC MODEL 526A