

Operating Manual

OPTIMOD[®]-FM Six-Band Limiter Accessory Chassis

MODEL 8100A/XT

to accompany OPTIMOD-FM Model 8100A/1

orban



ADDENDUM

FOR MODEL 8100A/XT MANUAL (P/N 95041 - 000 - 01)

DATE 2/7/85

ISSUE: 02

PAGE 1 OF 1

ITEM	✓	PAGE	DESCRIPTION OF DWG.	ACTION	DWG. LOCUS	NOTE
1		J-2 J-3	Board #A1 Schematic & Assy.	Diodes CR1, 2, 11, and 12 are deleted. Resistor value changes: R6 & R37 was: 64.9K is: 47.5K R5 & R36 was: 54.9K is: 73.2K		TPF 093 ECO 643 <u>Upgrade #1</u> Improved frequency balances
			Board #A2 Schematic & Assy.	Resistor value changes: R47 & R49 was: 2.00K is: 1.00K R51 was: 6.8K is: 3.3K		
2		J-2 J-3	Board #A1 Schematic & Assy.	Resistor value changes: R70 & R115 was: 523.0K is: 649.0K R71 & R116 was: 82.5K is: 102.0K R73 & R118 was: 562.0K is: 698.0K		TPF 125 ECO 687 <u>Upgrade #2</u> ("M03" on S/N label) Improved frequency balances
		J-6 J-7	Board #A3 Schematic & Assy.	R160 was: 150.0K is: 75.0K		

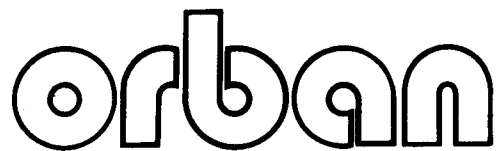

ADDENDUM

Upgrade #2 for Optimod-FM Accessory Chassis Model 8100A/XT

This 8100A/XT Accessory Chassis is equipped with Upgrade #2 (as indicated by its Serial Number being 738000 or above, or by the number M03 appearing on the Serial label). This Addendum outlines variations from the Manual supplied pending its reprinting.

The Program Director will be very interested in reading the first portion of these instructions, appropriate sections of the "XT" manual, and those of the Main processor manual.

Introduction:

The 8100A/XT chassis was developed as an accessory to the 8100A Optimod-FM to meet the emerging needs of stations who find that, for certain formats and for local competitive reasons, a denser sound with greater consistency of texture and of frequency balance from source to source best meets the overall programming objectives.

Upgrade #2, which is installed in this unit, is intended to increase impact and is expected to be most beneficial for Rock and Contemporary Hit Radio (CHR) formats. It will increase both "punch" and "sizzle" and should result in a loudness increase -- you could call it a "show-biz" effect.

The "XT" chassis, with or without this Upgrade, may be louder or less loud than an aggressively adjusted 8100A by itself! It depends the program material. For example, with Heavy Metal, the 8100A will probably be louder without the "XT" because the energy in the 3-4 kHz (mid-range) region will be less limited by the 8100A's wider-band processing. In contrast, naturally-dull material will be substantially brightened by the "XT" and will be made louder than with the 8100A alone. The Six-band Limiter changes the frequency balances in a highly controlled dynamic manner.

The user of the Model 8100A/XT 6-band Accessory Chassis should recognize that, even with this Upgrade, the Optimod-FM system might conceivably still be beaten by a small margin in a raw loudness contest, depending somewhat on the format. There seems to be no limit to the compromises possible to achieve more loudness if no weight is allotted to listener fatigue, irritating distortion, pumping and other processing artifacts! Insufficient valuation of these negative factors may result in a very noticeable decline in quarter-hour maintenance and a reduction in share due to evaporation of listeners who consciously or otherwise can't tolerate the subtle problems. (Women's ears seem to be peculiarly sensitive to irritations men can't hear. Younger ears are more sensitive than older ones.) The Optimod-FM system, by this Upgrade, has been extended to meet all reasonable contemporary programming needs.

Summary of Results to be expected from Upgrade #2:

Brightness is increased resulting in a unique sense of "air", brilliance and clarity. The effect is similar to that achieved by a "psychoacoustic exciter" but without the tendency to "spittiness" in speech or in cymbal sounds. This is accomplished by increasing the quiescent gains of the upper two bands thereby effectively providing a HF boost equalization. These gains can be readjusted in the field if desired. The patented distortion-cancelled clipper prevents unpleasant distortion.

Bass "punch" (the 'sock-in-the-gut' quality) is increased without introducing a "boomy" or "muddy" sound due to excessive mid-bass boost. You will now be able to use more bass boost (by use of the Bass EQ controls on the "XT") without introducing muddiness. The Upgrade retunes the Bass Equalizer center frequency from 80 Hz to 65 Hz to permit this.

Technical Details:

The several resistor values changed are shown on the Addendum Chart inserted into your manual.

The quiescent gains of the upper two bands are increased by adjustment of trimmers R133 and R161 on board A3. It was necessary to decrease the value of resistor R160 to expand the range of R161.

As shipped, the gain of the 3.7 kHz band (Band 5) is boosted 1 dB; the gain of the 6.2 kHz band (Band 6) is boosted 3 dB. These gains can be changed in the field if desired.

The boosting of these gains means that the 8100A/XT chassis will no longer be 'flat' in the PROOF mode as it was before. Thus, if a "PROOF" is to be performed on the host a jumper plug must be installed in place of the "XT" chassis. Connections are described below. (PROOFs are no longer an FCC requirement and would only be done if, for some reason, performance was suspect.)

The Bass part of the Upgrade retunes the Bass Equalizer center frequency from 80 Hz to 65 Hz to permit more bass boost using the two Bass EQ controls. There is no reason to further adjust this value in the field. (Note that the bass equalizers, while centered at 65 Hz, affect the bass up to approximately 130 Hz.

> Changing the HF boost characteristics:

You will need the following tools and instruments:

- #1 Phillips head screwdriver to remove the bottom cover
- 1/8" Flat blade screwdriver to adjust trimpots
- Sharp soft pencil to mark new trimmer positions

Summary of Results to be expected from Upgrade #2:

Brightness is increased resulting in a unique sense of "air", brilliance and clarity. The effect is similar to that achieved by a "psychoacoustic exciter" but without the tendency to "spittiness" in speech or in cymbal sounds. This is accomplished by increasing the quiescent gains of the upper two bands thereby effectively providing a HF boost equalization. These gains can be readjusted in the field if desired. The patented distortion-cancelled clipper prevents unpleasant distortion.

Bass "punch" (the 'sock-in-the-gut' quality) is increased without introducing a "boomy" or "muddy" sound due to excessive mid-bass boost. You will now be able to use more bass boost (by use of the Bass EQ controls on the "XT") without introducing muddiness. The Upgrade retunes the Bass Equalizer center frequency from 80 Hz to 65 Hz to permit this.

Technical Details:

The several resistor values changed are shown on the Addendum Chart inserted into your manual.

The quiescent gains of the upper two bands are increased by adjustment of trimmers R133 and R161 on board A3. It was necessary to decrease the value of resistor R160 to expand the range of R161.

As shipped, the gain of the 3.7 kHz band (Band 5) is boosted 1 dB; the gain of the 6.2 kHz band (Band 6) is boosted 3 dB. These gains can be changed in the field if desired.

The boosting of these gains means that the 8100A/XT chassis will no longer be 'flat' in the PROOF mode as it was before. Thus, if a "PROOF" is to be performed on the host a jumper plug must be installed in place of the "XT" chassis. Connections are described below. (PROOFs are no longer an FCC requirement and would only be done if, for some reason, performance was suspect.)

The Bass part of the Upgrade retunes the Bass Equalizer center frequency from 80 Hz to 65 Hz to permit more bass boost using the two Bass EQ controls. There is no reason to further adjust this value in the field. (Note that the bass equalizers, while centered at 65 Hz, affect the bass up to approximately 130 Hz.

> Changing the HF boost characteristics:

You will need the following tools and instruments:

- #1 Phillips head screwdriver to remove the bottom cover
- 1/8" Flat blade screwdriver to adjust trimpots
- Sharp soft pencil to mark new trimmer positions

Procedure

The HF boost must be adjusted only by ear while the unit is passing typical program material.

Both the host Optimod-FM and the XT chassis must be arranged in such a way as to permit access to the trimmers at the bottom front area of the XT chassis when its bottom cover is removed and the unit is passing signal. Some creativity may be required. The screwdriver mounted on the door of the host unit may be useful.

Using the layout diagram in the Manual for the A3 board of the XT (page J-8), locate trimmers R133 (affects Band 5) and R161 (affects Band 6). Note that both trimmers carry marks which indicate the 'flat' setting for each band. These marks are provided for your reference. The trimmers themselves were factory adjusted to +1dB and +3dB boosts respectively.

Mark the factory settings of these two trimmers so the trimmers can be restored later if desired. It would be wise to use a different color ink and to make a note of your color.

Have a selection of typical program material available. Play this material and make a small adjustment in one trimmer. Listen (or have the Program Director listen) on a good quality receiver in a familiar listening environment. Make further adjustments as desired.

For Band 6 (6.2 kHz):

The program can be made slightly brighter or slightly duller at the high end according to taste by adjusting trimmer R161. It would be wise to make one adjustment in the desired direction and then listen to different types of program material.

Caution: Boosting the EQ above the factory +3dB in this band might emphasize noise, hiss or HF distortion when you encounter poorer program material. With such aggressive processing, the program material must be as clean as possible. CD's, when available, are excellent choices for maximum results.

For Band 5 (3.7 kHz):

Perform the same procedure as above using trimmer R133.

Caution: While more boost can be obtained here than the factory supplied +1dB, resulting in more loudness, it will also result in more stridency and irritation. Band 5 affects a highly sensitive region of hearing. We do not recommend more than a 1 dB boost as supplied.

It would be wise to annotate your XT Manual's Proof of Performance section (pg. 4-1) and also to apply an adhesive label to the subpanel advising of your final variation from 'flat' for future reference.

If you later wish to restore the unit to the factory condition, simply readjust the trimmers to the original marks.

Note: The confident craftsman may wish to replace one or both trimmers with 100K panel-mount trimmers mounted in the subpanel for more convenient access to the adjustments in the future.

> Bypass Connector wiring diagram.

The XT has been purposely made 'unflat' by Upgrade #2. The 'Proof' switch can no longer make it 'flat' as it did before. Before 'deregulation' it was mandatory to be able to defeat all processing for Proofs without its removal from the program path — this is no longer true.

Should you wish to perform a "Proof" on the Optimod-FM host, it will be most convenient to simply bypass the XT chassis. Wire a DB-25P connector (available from Cinch, Cannon, Amphenol and many others) according to the wiring diagram below and use it when a "Proof" is to be performed.

Otherwise, you must restore the 'flat' condition by resetting both trimmers to their marked flat positions, or by recalibrating the circuits using instruments.

If not available locally, the connector may be purchased through Orban Customer Service.

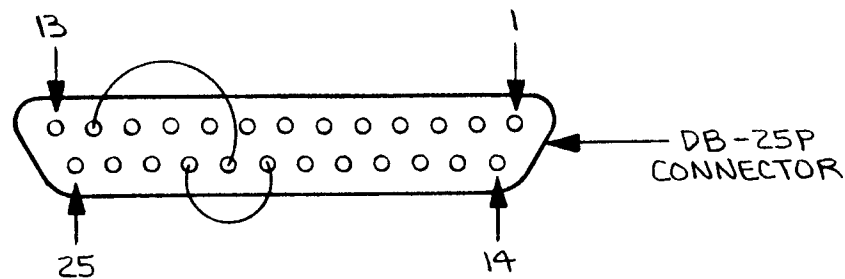

REAR VIEW

JUMPER PLUG FOR PROOFS
WITH "XT" CONFIGURATION

PIN		FUNCTION
FROM	TO	
20	22	L-LIMITER OUT TO 15 KHZ FILTER IN
21	12	R-LIMITER OUT TO 15 KHZ FILTER IN

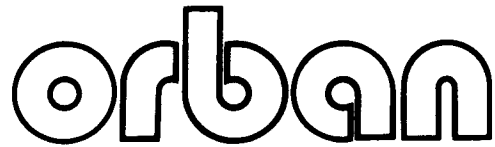

PLEASE READ THIS FIRST!

SUPPLEMENT TO THE 8100A/XT OPERATING MANUAL

(Applies to Manual P/N 95041-000-01)

IMPORTANT: This document describes a modification to the host mainframe which may be required to assure that its power supply regulator does not go into current limiting under certain operating conditions. Please read this procedure carefully to determine if your host needs the modification.

Modification Of The Main-Chassis Power Supply

Determining If The Modification Is Necessary: If you have an 8100A/1 with a serial number of 699000 or above, the modification has already been performed at the factory and you may skip to the section on **Application Notes** below.

Units (8100A or 8100A/1) with serial numbers prior to 684000 were not factory-modified and must be checked according to the instructions below.

Some units between 684000 and 699000 have been factory-modified. Please check as below.

How To Check Positively: Gain access to the circuit cards following the instructions in **Appendix C** of your main **Optimod Operating Manual**. [If you are presently installing the XT chassis, the instructions in **Part 2 (Installation)** of your **XT Operating Manual** will require you to do this anyway to move jumpers on the host mainframe circuit cards. To save effort, you can make this observation at the same time.]

The power supply regulator card (Card #PS) is mounted on the inside of the rear panel, and you can see it by looking towards the back of the chassis through the empty space to the left of Card #3. There are two large resistors (R103 and R104) mounted on this card. Check their value: if they are 0.62ohms (blue-red-gold-gold), then the modification is not required, and you may skip to **Application Notes** below. If they are 0.91ohms (white-brown-gold-gold), then the modification is required.

In some units, the resistor values may have been changed by soldering a piggyback

resistor of 1.8ohms (brown-gray-silver) across the 0.91ohm resistors. In this case, the modification is not required, and you may skip to **Application Notes** below.

Modification

Please refer to **Appendix C** of your main **Optimod Operating Manual** for instructions on access to Card #PS (the power supply regulator). This card is mounted on the rear panel, and accessing it requires removing the rear panel. Following the instructions in **Appendix C** will save you time because you will find that the top and bottom covers do not have to be removed.

Refer to the Assembly Drawing for the Power Supply Regulator in **Appendix J** of your main **Operating Manual** and locate R103 and R104. Find the 1.8ohm (brown-gray-silver-silver or brown-gray-silver-gold) 1w wirewound resistors included in the parts kit. Bend each lead of the 1.8ohm resistors at right angles about 1/8" from the resistor body. Connect one of the new resistors in parallel with R103 and one in parallel with R104 by "piggybacking" the new resistors onto the old. Solder the new resistors to the leads of the old resistors as far away from the resistor bodies as practical to prevent damage from excessive heat.

This concludes modification of the host chassis power supply. Reassemble the rear panel to the chassis, following the instructions in **Appendix C**. If you have not yet checked the positions of the jumpers on Cards #5, 6, 8, and 9 of the host chassis (as described in **Part 2** of the **XT Operating Manual**), do not replace the subpanel yet.

We suggest that you mark the changes in the Schematic and Parts List for the main **Optimod Operating Manual**.

APPLICATION NOTES

NOTE: These notes complement (and sometimes supercede) the setup instructions in **Part 3** of the **XT Operating Manual**. They are based on experience not available at the time that the **XT Operating Manual** was written. Any part of these notes which supercede instructions within the **XT Operating Manual** will be clearly indicated in the text.

Adjustment Of XT Operating Controls: We recommend setting the CLIPPING control at "0" and advancing the DENSITY control to the point where the 700Hz and 1.6kHz G/R meters indicate between 2 and 5dB G/R with typical program material. (This supercedes the "less than 10dB G/R" suggestion in the **Operating**

Manual.)

Use of more G/R than this will not result in more loudness, because you will have to compensate for the increased density by turning the CLIPPING control down to avoid audible distortion. Further, more G/R will tend to produce a "wall-of-sound" effect which can be quite fatiguing in the long-term. Don't conclude that you are somehow not using the XT to its fullest potential because the G/R meters don't seem to be very active. You will be surprised at how much "automatic equalization" and brightening of naturally-duller program material will occur even with this seemingly conservative setting.

About Loudness: The XT uses the same peak limiting system as the basic 8100A/1. We believe this to be the most advanced peak limiting system available for FM. Because the same peak limiting system is in use when the XT is installed, the XT can get no louder than the 8100A/1 when the latter is set for fast release times and its input is modern, brightly-mixed program material: the 8100A/1 is already a very loud processor. (We told you this in the XT brochure, but we're repeating it here for good measure.)

The XT will be louder than the 8100A/1 when the source material is dull, because the XT will automatically re-equalize such material to make its spectral balance more typical of current recorded product. Loudness will often be increased because of a dynamic upper midrange boost.

Because the XT setup controls were designed with wide range, it is possible to adjust the XT to create audible distortion due to excessive clipping. If the mainframe VU meter in L FILTER OUT or R FILTER OUT consistently indicates peaks higher than about -2VU, distortion is likely to be audible. You must then turn down either the XT's DENSITY control or its CLIPPING control until the meter reads -2VU or less and/or no objectionable distortion is heard. (To a certain extent, this adjustment is a function of your taste and format: it represents a classic processor loudness/distortion tradeoff.)

High source quality is even more crucial for successful XT processing than for successful 8100A/1 processing. If the source material is even slightly distorted, such distortion can be greatly exaggerated by the XT -- particularly if a large amount of G/R is used. If you feel that the XT is producing objectionable distortion when the mainframe VU meter is indicating -2VU or less (see above), then source quality is highly suspect. Worn or mistracking stylii can cause particularly objectionable problems, and use of audiophile-grade phono cartridges with elliptical stylii can pay substantial dividends. Compact Discs are an excellent source if low distortion is required (as it is here)! **Appendix K (Achieving High**

Source Quality) in your main **Optimod Operating Manual** has many more hints and observations which may help you identify and clean up distortion problems.

About Bass: Upgrades made to the XT since its **Operating Manual** was written have substantially "opened up" the bass power-handling capacity of the processing. If the bass response of the input to the processing is satisfactory, you will probably want to use little or no BASS EQ (contrary to the instructions in your **XT Operating Manual**).

If desired, bass boost can be achieved not only by using the BASS EQ controls on the XT, but also by using the BASS COUPLING control on the mainframe. These controls have different effects: the BASS COUPLING control causes a shelving boost starting at about 200Hz (increasing "warmth"); the BASS EQ controls on the XT cause a peaking boost at 80Hz (increasing "punch"). We advise using the BASS COUPLING control very sparingly, if at all, because of the danger of introducing muddiness, particularly in cars with 180-200Hz dashboard resonances. Use of the XT BASS EQ control is substantially less risky because its peak frequency is well away from the typical dashboard resonance frequency.

About Treble: Upgrades made to the XT since its manual was written substantially increase the contribution of Band 6 (above 6.2kHz) to the overall XT output spectrum. This increases "air" and "brilliance", but makes the requirement for clean source material somewhat more critical. The modification was guided by careful A/B comparisons with a stock 8100A/1, whose design permits outstanding high-frequency power-handling without audible distortion. Well-recorded current records with typically bright contemporary equalization will have approximately as much high frequency energy with the XT as without. A few records (which we consider "shrill" with excessive highs) will be rolled-off slightly by the XT when compared to the 8100A/1. Many records (particularly slightly older ones) will sound brighter and better-balanced and will have more presence when processed through the XT.

We do not believe that it is possible to get an even brighter sound without substantial compromises in loudness, naturalness, or distortion. Nevertheless, if that is your desire, you can try putting an equalizer or "exciter" in the program line in the front of the XT or, preferably, you can apply such processing selectively in the production studio when music is being taped or carted. However, beware the possible side-effects: increased HF density, distortion, build-up of hiss, and a generally unnatural, unpleasant, fatiguing sound.

95043-000-01 6/84

Table of Contents

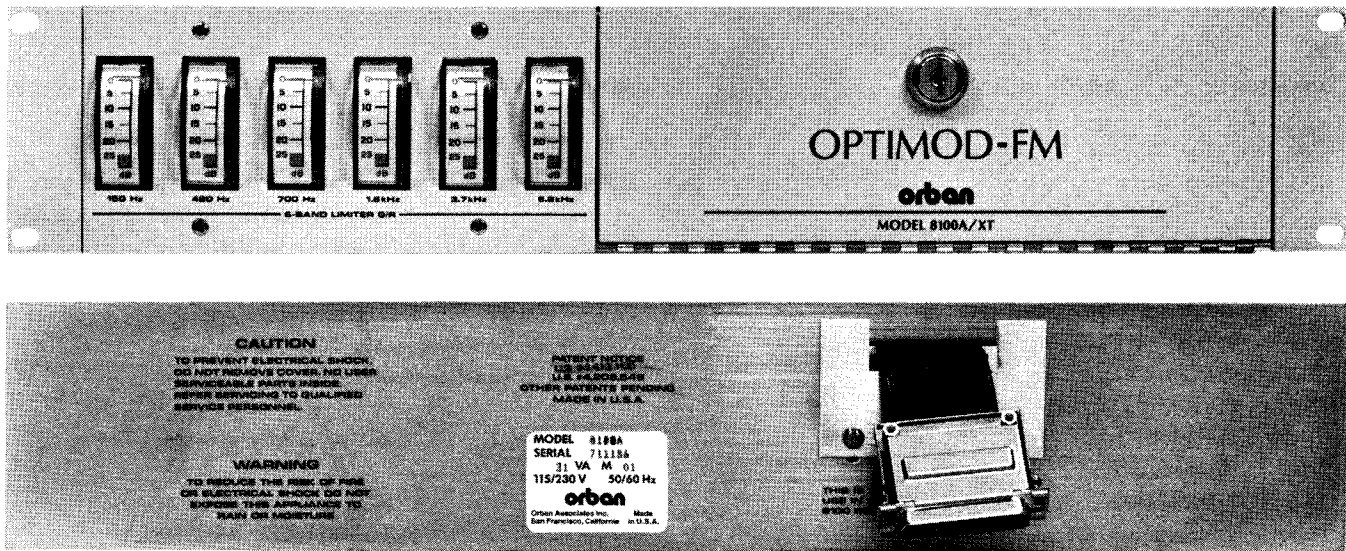

PREFACE

- Registration Card
- Warranty
- Fig. A-1: Duplicate Registration Card

PART 1: INTRODUCTION

- 1-1 Objective
- 1-1 Host Processor Interface
- 1-2 System Configuration
- 1-2 Simplified System Description
- 1-2 Relationship Between the XT and the Main Chassis
- 1-2 AGC
- 1-2 Bass Equalizer
- 1-3 Six-Band Limiter
- 1-3 Multiband Distortion-Cancelled Clipper

PART 2: INSTALLATION

- 2-1 Relationship To The Studio Chassis Model 8100A/ST
- 2-2 Fig. 2-1: Strapping Card #5 Jumpers For "Stock" 8100A Operation
- 2-3 INSTALLATION PROCEDURE
- 2-3 General Comments On Installation
- 2-3 Procedure A: Model 8100A/1 Jumper Setting
- 2-4 Procedure B: Model 8100A Connector Installation
- 2-4 Fig. 2-2: 25-Pin Connector Wiring Diagram
- 2-5 Procedure C: Model 8100A Card Modifications
- 2-6 Rework Procedure For Card #6
- 2-7 Fig. 2-3: Card #6 Rework
- 2-8 Rework Procedure For Cards #8 and #9
- 2-9 Procedure D: Final Operations

PART 3: SETUP

- 3-1 General
- 3-1 Adjustment Of The Main Chassis Controls
- 3-2 Adjustment Of The 8100A/XT Controls
- 3-2 Bass EQ (L and R)
- 3-2 Density
- 3-3 Clipping
- 3-3 Putting The System On The Air
- 3-3 Cautions
- 3-4 New Installations
- 3-4 Program Tests
- 3-4 Realignment For Absolute Maximum Loudness
- 3-5 Realignment Procedure

PART 4: PROOF OF PERFORMANCE

APPENDIX A: SYSTEM DESCRIPTION

- A-1 Main Chassis HF Limiter And Main Clipper Defeat
- A-1 Bass Equalizer
- A-1 Six-Band Limiter And Distortion-Cancelled Multiband Clipper
- A-2 Pre-Limiter Crossovers
- A-2 Voltage-Controlled Amplifier Operation
- A-3 Six-Band Limiter Control Circuitry
- A-3 Post-Compressor Crossover, Clippers, and Distortion-Cancellation System

APPENDIX B: CIRCUIT DESCRIPTION

- B-1 Main Chassis Limiter And Main Clipper Defeat
- B-1 Bass Equalizer
- B-1 Pre-Compressor Crossovers
- B-1 Voltage-Controlled Amplifier Operation
- B-3 Six-Band Limiter Control Circuitry
- B-3 Post-Compressor Crossover, Clippers, and Distortion-Cancellation System

APPENDIX C: USER ACCESS

- C-1 Routine Access
- C-1 Service Access

APPENDIX D: FIELD AUDIT OF PERFORMANCE

- D-1 Required Equipment
- D-2 Fig. D-1: Pink Noise Generator
- D-2 Audio Processing
 - D-2 Standard Control Setup
 - D-2 Skeleton Proof
- D-4 Operate-Mode Measurements
 - D-4 Pink Noise Tests
- D-5 Verification Of Distortion Cancellation
- D-6 Figs. D-2 to D-6: Distortion Cancellation

APPENDIX E: FIELD ALIGNMENT PROCEDURE

- E-1 General
- E-1 Required Test Equipment And Materials
- E-2 Alignment Of Voltage-Controlled Amplifiers
 - E-2 Concept
 - E-2 Distortion Null
- E-3 Thump Null
- E-3 Six-Band Limiter VCA Calibrate

APPENDIX F: TROUBLE DIAGNOSIS AND CORRECTION

- F-1 VU Meter Technique
- F-1 Card Swap Technique
- F-2 CATALOG OF TYPICAL SYMPTOMS
 - F-2 Problems With Subjective Sound Quality
 - F-2 Output Frequency Balance Doesn't Sound Like Input
 - F-2 Voice Too Loud
 - F-2 Gross Distortion
- F-3 Moderate To Subtle Distortion
- F-3 Sibilance Distortion

APPENDIX G: RESTORING THE 8100A TO "STOCK" CONDITION

APPENDIX H: MODIFYING THE MAIN CHASSIS TO ACHIEVE MORE NOISE REDUCTION IN GATED MODE

- H-1 Purpose Of Modification
- H-1 Required Materials
- H-1 Modification Procedure

APPENDIX I is intentionally omitted

APPENDIX J: SCHEMATICS, ASSEMBLY DRAWINGS, AND PARTS LIST

- J-1 TABLE OF CONTENTS FOR APPENDIX J
- J-2 Assembly Drawing: Crossover Board #A1
- J-3 Schematic Diagram: Crossover Board #A1 (1 of 3)
- J-4 Schematic Diagram: Crossover Board #A1 (2 of 3)
- J-5 Schematic Diagram: Crossover Board #A1 (3 of 3)
- J-6 Assembly Drawing: Limiter Control Board #A2
- J-7 Schematic Diagram: Limiter Control Board #A2
- J-8 Assembly Drawing: VCA Board #A3
- J-9 Schematic Diagram: VCA Board (1 of 2)
- J-10 Schematic Diagram: VCA Board (2 of 2)
- J-11 BLOCK DIAGRAM
- J-12 Connection List For Flat Cables
- J-13 Assembly Drawing: 8100A/1 Audio Control Card #5
- J-14 Schematic Diagram: 8100A/1 Audio Control Card #5
- J-15 PARTS LIST
- J-15 OBTAINING SPARE PARTS
- J-22 Vendor Codes

APPENDIX K is intentionally omitted

APPENDIX L: SPECIFICATIONS (SUPPLEMENTARY)

PART 1: Introduction

This Manual refers frequently to the Operating Manual for the main processor, and must be used in close conjunction with that manual.

Objective: The Orban 8100A/XT Six-Band Limiter Accessory Chassis for OPTIMOD-FM (Models 8100A and 8100A/1) has been created to provide aggressive multiband processing for stations that desire bright, loud, "highly-processed" audio. Derived from OPTIMOD-AM Model 9100A, the 8100A/XT consists of a stereo Bass Equalizer, and a stereo six-band limiter cascaded with the exclusive Orban distortion-cancelling multiband clipping system. When added to the basic OPTIMOD-FM system, the unit creates a dense, consistent sound without pumping or other obvious processing artifacts.

For convenience, we will hereafter refer to the 8100A/XT Six-Band Limiter Accessory Chassis as the "XT". All future mentions of the "8100A" mean the 8100A/1, or the 8100A as modified by means of retrofit kit RET-27 to function as an 8100A/1, unless the context clearly indicates otherwise.

Functionally, the unit replaces the high frequency limiter within OPTIMOD-FM Model 8100A, and permits the following objectives to be met:

- Increased loudness for a given level of audible processing side-effects (by comparison to an unmodified 8100A);
- Improved consistency from source to source due to the "automatic equalization" effect of the six-band limiter; and,
- Increased presence and intelligibility on smaller radios and in autos.

The XT is particularly suited for highly competitive pop music formats, such as AOR, CHR, AC, and Urban Contemporary. Because it has been specifically "tuned" to the OPTIMOD-FM system, it minimizes processing side-effects when compared to complex processing systems that use OPTIMOD-FM cascaded with other processors.

Please note that OPTIMOD-FM with the XT will be no louder than the basic OPTIMOD-FM operated with very fast release times and large amounts of clipping -- OPTIMOD-FM is already a very loud processor. The primary advantages of the XT are improved consistency, increased brightness on naturally-dull program material, and reduction of audible processing side-effects -- all while retaining the high loudness capabilities of an aggressively-operated 8100A.

Host Processor Interface: The XT interfaces directly to the Model 8100A/1 through a 25-pin connector provided as "Accessory Port #2". To reconfigure the main chassis for operation with the XT, it is only necessary to move plug-in jumpers on Cards #5, #6, #8, and #9.

The earlier Model 8100A can be easily converted to accept the XT by installation of retrofit kit RET-27 available from dealers or from the factory. This kit includes a replacement Card #5, a prewired 25-pin connector, and other parts. Instructions for installation of RET-27 are provided in this manual.

System Configuration: The XT is housed in a 3 1/2" chassis which always resides directly below the host 8100A or 8100A/1 and which derives its power from the host through the 25-pin connector.

The 8100A/ST Studio Accessory Chassis (which is used to implement the "split" studio/transmitter configuration) is fully compatible with the XT.

Reconverting an 8100A/1 to operate without the XT is extremely easy, requiring that a few jumpers be restrapped. Reconversion of an 8100A is slightly harder, as some soldering is required. Instructions for reconversion are supplied in **Appendix G**.

SIMPLIFIED SYSTEM DESCRIPTION This section provides an understanding of the XT and its interaction with the OPTIMOD-FM Main Chassis sufficient to install and operate the units in an informed manner. More detailed discussions of the system from the point of view of troubleshooting and maintenance are found in **Appendix A (System Description)** and **Appendix B (Circuit Description)**.

Relationship Between The XT And The Main Chassis: The XT circuitry is inserted between the output of the 8100A's HF Limiter and the input of its distortion-cancelling 15kHz lowpass filter. The 8100A automatically senses when the XT is plugged into Accessory Port #2 and puts the 8100A HF Limiter and main clipper in PROOF mode, since these functions are now performed by the XT.

Virtually all other OPTIMOD-FM circuitry remains active when the XT is in use. Your **Optimod Operating Manual** provides descriptions and discussion of that circuitry, which includes the Input Conditioning Filter, the Dual-Band Compressor, the Preemphasis Filter, the Distortion-Cancelling 15kHz Lowpass Filter, the FCS Overshoot Corrector, and the Stereo Generator. The Dual-Band Compressor, Distortion-Cancelling 15kHz Lowpass Filter, and Proof/Operate control lines operate differently when the XT is in use. These variations are fully described below.

1) **AGC:** To prevent the existing Multiband Compressor in the Main Chassis from "fighting" the Six-Band Limiter in the XT due to time-constant incompatibilities, the time-constants of the existing Multiband Compressor are altered to convert it into a slow averaging device with an extremely long attack time. This retains transient definition and permits the section to function as a slow "hand on the pot", merely riding gain without affecting short-term density or texture. The various Master G/R meters on the Main Chassis will behave differently.

In the 8100A/1 (and the converted 8100A), this alteration is effected by moving jumpers on Card #5 in the Main Chassis. In the 8100A, Card #5 must be replaced to provide the new circuitry.

2) **Bass Equalizer:** The input signal to the XT (which has already been preemphasized by the 8100A) is applied to a Bass Equalizer. This can provide 0-10dB of peaking boost with a center frequency of 80Hz and a "Q" of 1.4 (approximately 1 octave). Because the XT often increases the brightness of program material, some bass boost is usually desirable to keep the sound spectrally well-balanced.

- 3) **Six-Band Limiter:** Following the Bass Equalizer, a set of six parallel filters divides the signal into frequency bands. The highest and lowest bands are lowpass and highpass respectively; the other bands are bandpass.

Unlike the three-band technique used in the unmodified 8100A, the six bands in the XT can perform significant correction of midrange frequency balances, and can yield a more consistent, intelligible, and pleasing sound if the frequency balance of the input program material tends to vary uncontrollably. The six bands are particularly useful in correcting intelligibility problems with low-grade speech from telephone calls or other actualities.

To permit large amounts of limiting without interaction and pumping, the filters have been designed with 12dB/octave slopes. When the filters' outputs are summed after the multiband clipper (which contains further filtering), the resulting output is typically flat ± 0.25 dB over the frequency range of OPTIMOD-FM. Due to careful computer design of the filters, audible "holes" are not added to the frequency response under dynamic conditions.

Each filter is followed by its own limiter. The characteristics of these limiters are extremely critical if proper frequency response and inaudible operation are to be maintained under dynamic program conditions. For this reason, none of the individual limiter characteristics are user-adjustable.

There are two user controls affecting the Six-Band Limiter section: The DENSITY control, which adjusts the gains of all the VCA's within the Six-Band Limiter (determining how much gain reduction will be produced for a given setting of the CLIPPING control), and the CLIPPING control, which adjusts the threshold of limiting of all six limiters simultaneously (controlling the output level of the band-limiters, and thus the drive into the following multiband clipper). Together, the DENSITY and CLIPPING controls determine the amount of multiband limiting produced under operating conditions: Turning the DENSITY control clockwise and/or turning the CLIPPING control counterclockwise will produce more limiting.

The Six-Band Limiter section, because it operates in several frequency bands and exploits the "masking effect", is capable of far more fast gain control without audible side-effects than the wider bands used in the unmodified 8100A compressor. We call the Six-Band Limiter the "density augmentation" section because the individual limiters operate with fast release times and substantially decrease the peak-to-average ratio of the signal without the modulation effects which would result if only one limiter were used for the entire frequency spectrum.

If input levels are not well-controlled, multiband AGC devices can introduce so much gain difference between bands that program material sounds unnatural (due to non-flat frequency response). As the average gain reduction in the multiband section increases, these problems tend to worsen. To control such potential difficulties, average levels into the Six-Band Limiter section are controlled by the slow AGC so that excessive gain reduction never occurs in the Six-Band Limiter section.

- 4) **Multiband Distortion-Cancelled Clipper:** The outputs of five of the six band-limiters are applied to their own individual clippers. These clippers are all followed by filters to reduce the out-of-band harmonic and/or IM distortion caused by the clipping. In addition, the distortion caused by clipping the upper four bands is sharply cancelled below 2.2kHz by means of a feedforward distortion-cancelling sidechain which works in parallel with the main 15kHz lowpass filter. (Both filters are located in the Main Chassis).

The result of the distortion filtering and cancellation is an effective reduction of the peak-to-average ratio of the signal without the expected distortion buildup due to clipping, yielding an unusually favorable tradeoff between loudness and distortion. A particularly notable advantage of this scheme is that the summed outputs of the six clippers can be applied to a safety clipper for final peak limiting without the need for further broadband gain control, thereby avoiding potential pumping and modulation effects. In this system, the FCS Overshoot Compensator (in the Main Chassis) serves as a "bandlimited safety clipper" to effectively control peak modulation without introducing out-of-band energy which could cause losses of dynamic separation and increases in main-to-sub crosstalk.

(This scheme is protected by U.S. Patents #4,208,548 and #4,412,100.)

This concludes the **Simplified System Description.**

PART 2: Installation

The Model 8100A/XT Six-Band Limiter Accessory Chassis ("XT") should not be installed until the main system has been installed and thoroughly tested on the air.

Install the host OPTIMOD-FM in your station using the instructions provided in the **Optimod Operating Manual**. Perform all setup and installation steps and on-air tests before installing the XT.

The installation procedure for the XT depends on the model number and serial number of the OPTIMOD-FM host unit. These numbers are shown on the serial label at the rear of your unit.

In every case, some resetting of jumpers within the main chassis of OPTIMOD-FM will be necessary, so installation must be done with OPTIMOD-FM off-the-air. No adjustments within the XT are required.

In every case, the XT chassis mounts immediately below the host OPTIMOD-FM and is connected to it by a short cable attached to the XT. (This cable must be kept short to avoid RFI problems.)

It is relatively easy (by movement of jumpers) to reconfigure a model 8100A/1 OPTIMOD-FM for use either with or without the XT. Reconfiguration of older Model 8100A units (prior to serial number 638000) requires a slight amount of soldering rework on various cards.

Instructions for access to various areas mentioned are given in **Appendix C** of the **Optimod Operating Manual**. To save time and avoid damage, please follow these instructions carefully.

Locations of components mentioned in the rework instructions are shown on assembly drawings in **Appendix J** for the **Optimod Operating Manual** for Model 8100A. The assembly drawing and schematic drawing for the #5 Card required for the adaptation of older units (via Retrofit Kit RET-27) are included in this manual.

RELATION TO THE STUDIO CHASSIS MODEL 8100A/ST

The Six-Band Accessory Chassis Model 8100A/XT is compatible with OPTIMOD-FM installations which use the Studio Accessory Chassis Model 8100A/ST to place the compression function before the STL to optimize STL noise performance. If you are not using the Model 8100A/ST, please skip to **General Comments On Installation** below.

In all cases, the Six-Band Accessory Chassis Model 8100A/XT resides at the same site as the Main Chassis: ordinarily at the transmitter unless a composite STL is used.

We recommend that the 8100A/ST and the Main Chassis be matched to each other (following the procedure in **Electrical Alignment** on page 6 of the **8100A/ST Operating Manual**) before the Main Chassis is converted to accept the Model 8100A/XT. This way, the instructions in the 8100A/ST Manual apply whether or not the 8100A/XT is used. [To facilitate adjusting the Model 8100A/ST, all 8100A/1 Main Chassis are shipped with the cards jumpered in "normal" (i.e., non-8100A/XT) mode, and must be converted according to the instructions below before they can be used with the 8100A/XT.]

The only card directly affected is Card #5. (In the 8100A/ST Manual, you are instructed to move this card from the Main Chassis to the Model 8100A/ST). In the case of the Model 8100A, the original Card #5 should be placed in the Model 8100A/ST to perform the level alignment. (If the replacement card were used instead, several jumpers would have to be moved just for the level alignment, which might invite errors.) After the alignment is finished, the original Card #5 must be replaced with the Card #5 included in your 8100A/XT conversion kit. (Check to make sure that this card is strapped according to Paragraph A1 in **Procedure A** below.) So wait until the level matching and card swapping procedures are complete before you replace the 8100A/ST cover and mount it permanently in the rack.

Model 8100A/1 already contains a Card #5 with the necessary jumpers. Strap this card according to Fig. 2-1 below before performing the level alignment. After level alignment is completed, restrap the card according to Paragraph A1 in **Procedure A** below. You may then replace the 8100A/ST cover and mount it in the rack.

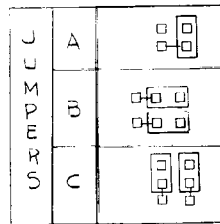

Fig. 2-1: STRAPPING CARD #5 JUMPERS FOR "STOCK" 8100A OPERATION
(Mainframe will have S/N 638000 or greater)

Please note that accurate level alignment between the Main Chassis and the 8100A/ST is much less critical when the 8100A/XT is in use because a stage of gain reduction has been placed between the input of the Main Chassis and its clippers, protecting the clippers from being overdriven in the event of gain errors. Nevertheless, following the suggestions above will result in the STL's being correctly aligned for the "stock" 8100 system without further adjustment if you wish to remove the 8100A/XT from service for any reason.

NOTE: When Card #5 is strapped for 8100A/XT operation, its limiting threshold is reduced and it no longer produces a "standard level" at the 8100A/ST output of +3.6dBm, nor does it cause the Main Chassis VU meter to read "0VU" in the L or R COMPRESSOR positions. Instead, its output is reduced approximately 5dB, causing the "standard level" test to produce -1.4dBm and the VU meter to read "-5VU".

The threshold is changed to compensate for the increased attack time, which increases overshoots on program material. Accordingly, peak levels on program material stay roughly the same regardless of the mode of operation of Card #5, and STL peak modulation should also stay approximately the same.

INSTALLATION PROCEDURE

General Comments On Installation: If you have a Model 8100A/1 of any serial number (will be 638000 or higher), your unit has been factory-equipped with a connector and internal jumpers to facilitate quick installation of your XT. Proceed now to **Procedure A** below. (Ignore **Procedures B** and **C**).

If you have a Model 8100A with a serial number below 638000, you must make minor modifications to certain cards. You will also have to install a connector to interface the XT and you may have to replace Card #5. Parts for the modifications are provided in Retrofit Kit RET-27, available from the factory. All instructions for installation of Retrofit Kit RET-27 are included in this Manual. Proceed now to **Procedure B**. (Skip **Procedure A**.)

PROCEDURE A: Model 8100A/1 Jumper Setting

(Will have serial number 638000 or over)

Allow about 30 minutes for this procedure.

No circuit modifications are required for this procedure. However, it is necessary to reset certain jumpers on Cards #5, 6, 8, and 9.

(For reference, **Appendix M** of the **8100A/1 Optimod Operating Manual** outlines the functions of the various jumpers.)

Jumpers may be reset from the front of the chassis, even if it is already installed in a rack.

Obtain access to the cards in the main chassis, referring to page C-1 of the **Optimod Operating Manual** under **Routine Access** (c).

NOTE

Reference herein to the **Optimod Operating Manual** means to the **8100A/1 Operating Manual**, which is clearly so marked on its cover. (To expedite deliveries of early units, some units were shipped with Model 8100A manuals accompanied by a four-page addendum supplying the revised drawings for Cards #5, 6, 8, and 9. These addenda supercede the drawings in the manual proper.)

Turn off the power.

A1) Jumper Setting For Card #5

A1.a) Move jumpers A, B, and C according to the assembly drawing in **Appendix J** of the **Optimod Operating Manual** (or the addendum).

A1.b) Re-install Card #5.

A2) Jumper Setting For Card #6

A2.a) Move the two links at jumper C to the (adjacent) jumper B according to the assembly drawing in **Appendix J** of the **Optimod Operating Manual**. (This drawing does not clearly label jumper C but the diagram is correct.)

For normal operation, note that the two links must be rotated 1/4-turn on jumper C as compared to jumper B.

Jumper A is not moved, remaining in the "8100A" position.

A2.b) Re-install Card #6.

A3) Jumper Setting For Cards #8 and #9

A3.a) Cards #8 and #9 are identical and should be set identically.

A3.b) On each of the cards, move the link at jumper B according to the assembly drawing in **Appendix J** of the **Optimod Operating Manual**.

Jumper A is not moved.

A3.c) Re-install Cards #8 and #9.

Proceed to **Procedure D** to complete the installation.

PROCEDURE B: Model 8100A Connector Installation
(Mainframes with serial numbers below 638000)

You will need Retrofit Kit RET-27. Allow about one hour for this procedure.

You will need to have the host OPTIMOD-FM removed from the rack and freely accessible on a bench.

B1) In the **Optimod Operating Manual**, read the paragraphs in **Appendix C** entitled **Access To Area Behind Rear Panel** (page C-2).

B2) Following these instructions (which will save you time), carefully open the rear panel.

B3) If a connector is installed in Accessory Port #1, remove the metal plate covering Accessory Port #2 and discard the plate and its fasteners.

If no connector is installed, remove the metal plate covering both Accessory Ports. Save the fasteners; discard the plate. Using these fasteners, install the metal plate from the Retrofit Kit over Accessory Port #1.

B4) Select the bag from the Retrofit Kit containing the wired 25-pin connector and its hardware. Referring to Fig. 2-2, check that the correct wire colors are connected to the pins specified and that all wires are present. This is good insurance: if there is an inadvertent error, it will be difficult to fix later!

B5) Referring to Fig. 2-2, install the connector with the hardware provided in the hole marked "Accessory Port #2". Use only moderate tightening force on the small screws. [Use a 3/16" (that is, #6) hex nutdriver. A 5mm nutdriver will also work.]

B6) Dress the wires as shown in Fig. 2-2, adjusting the cable ties as needed. Connect each wire to the mother board according to Table 2-1 below. The Retrofit Kit was conceived some time after the original design, so unfortunately, most wires will have to be carefully tack-soldered: we were unable to provide convenient terminals.

Table 2-1: Wire List For Connector "AP"

WIRE SCHEDULE			
FROM	TO	FUNCTION	WIRE
AP-1	AP-14	15V PROOF	.25 IN BUSWIRE
AP-2	AP-15	+15V	.25 IN "
AP-3	AP-16	-15V	.25 IN "
AP-4	AP-17	CHASSIS GND	.25 IN "
AP-5	AP-18	DIRTY GND	.25 IN "
AP-6	AP-19	CLEAN GND	.25 IN "
AP-12	J9-M	RISKY FILTER	BLK 14.5 IN INSULATED
AP-13	J9-P	R2.2 KHE FILTER	WHT 4.5 IN "
AP-14	J8-F	15V PROOF	VIO 15.5 IN "
AP-15	PS-6	+15V	BLU 9 IN "
AP-16	PS-8	-15V	GRY 7.5 IN "
AP-17	GND LUG	CHASSIS GND	BLK 2.5 IN "
AP-18	PS-7	DIRTY GND	BLK 7.5 IN "
AP-19	PS-7	CLEAN GND	BRN 7.5 IN "
AP-20	J6-I	LIMITER OUT	WHT 12.5 IN "
AP-21	J6-S	R LIMITER OUT	GRY 12.5 IN "
AP-22	J8-M	L 15KHE FILTER	RED 14 IN "
AP-23	J8-P	L 2.2 KHE FILTER	ORN 14 IN "

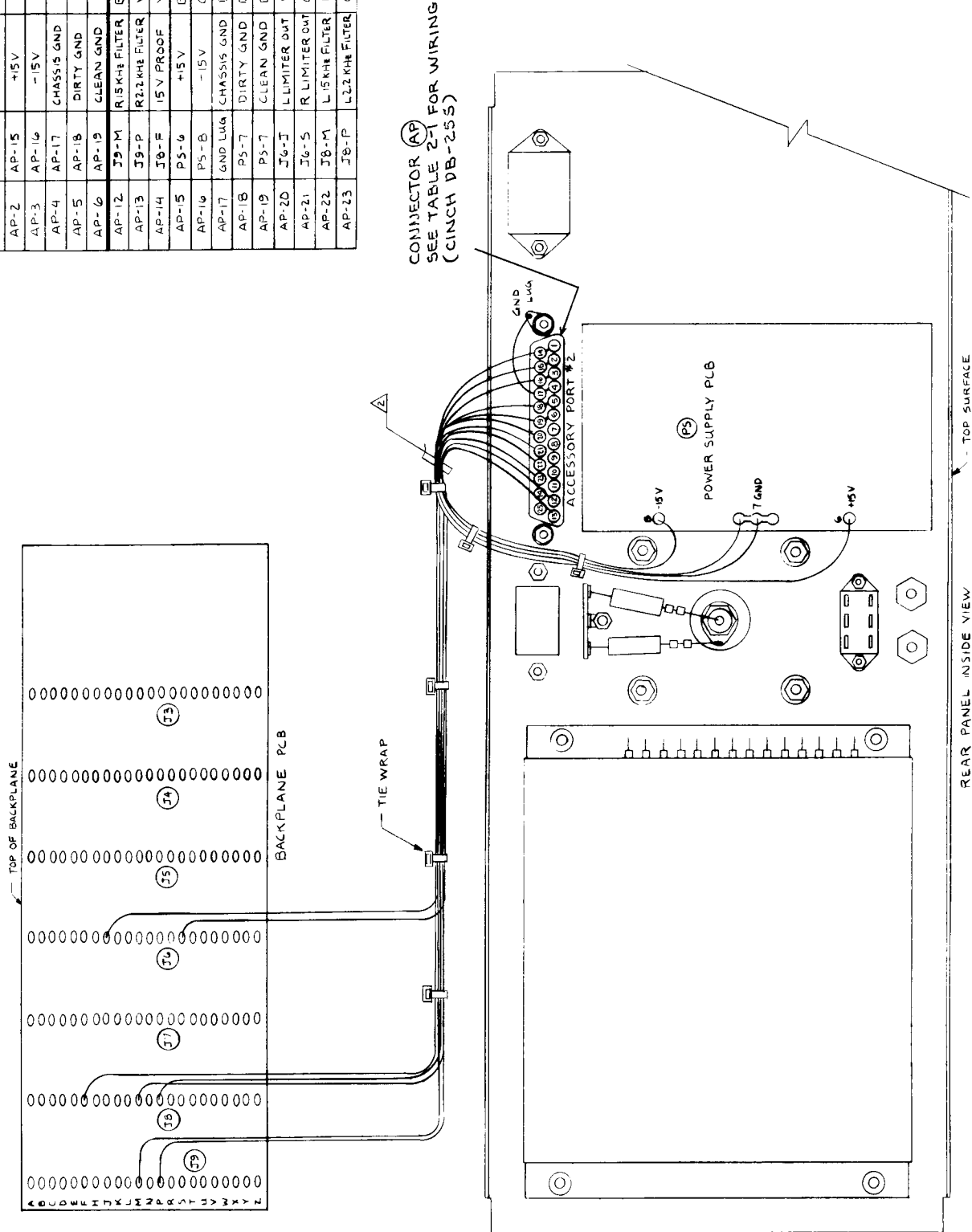

Fig. 2-2: 25-PIN CONNECTOR INSTALLATION

[**NOTES:** The wire lengths have been chosen to provide enough slack to enable other service operations on the rear panel to be performed. It would be unwise to shorten the wires. The routing shown should be followed to avoid possible crosstalk.

[It is safe to tack-solder to the motherboard with the circuit cards in place except in very high RF fields, in which case all cards should be removed. In any case, we recommend using a soldering iron with a grounded tip to minimize possibility of circuit damage.

[Avoid using excessive amounts of heat or flux at the motherboard. (The connectors could be damaged by tempering of the contacts through excessive heat or by creepage of flux.) In addition, because some of the motherboard traces are close together, inspect your work very carefully to be sure that you have not created solder bridges between traces or pads.]

B7) Reattach the rear panel by reversing the disassembly procedure. (Refer again to **Appendix C**, page C-2, of the **Optimod Operating Manual**.)

B8) Go to **Procedure C** below.

PROCEDURE C: Model 8100A Card Modifications

(Mainframes with serial numbers below 638000)

You will need Retrofit Kit RET-27. Allow about two hours for this procedure.

You may have to replace Card #5 (the replacement is included in the Retrofit Kit), and you may have to make circuit modifications to Cards #6, 8, and 9.

If your serial number is below 619780, you will have to perform all card rework operations in this procedure. If your serial number is between 619780 and 637999, you will have to examine each card subject to rework, and perform rework only on those cards that are not yet at the correct level.

Modifications are simple and require only common circuit board repair skills, appropriate tools, and a careful, systematic approach. Sage advice for reworking printed-circuit cards is found at the end of **Appendix F** in your **Optimod Operating Manual**.

C1) Remove Card #5 and examine the solder side.

If the part number etched on the card is 30741-000-03, the card you have is the correct one for use with the XT. You may reserve the #5 Card included with the Retrofit Kit and return it to the factory for credit. (See Step C5.)

If the part number etched on the card is 30451-000-nn (where -nn is any number) or 30741-000-02 or -01, you must replace the #5 Card with the card provided in the kit (which will have an etched number of 30741-000-03 or higher, but not lower).

The old card, while it will not operate perfectly with the XT, can serve as an emergency spare. (You may hear more processing artifacts.) This old card is not returnable.

(In either case, it might be convenient, while the card is out, to set the three jumpers according to the instructions in **Procedure A**, paragraph A1. Return to Step C2 below when those jumpers are set and the card is returned to its slot.)

C2) Remove Card #6 and examine the solder side.

If the part number etched on the card is 30461-000-05 or up, the card you have is the correct one for use with the XT.

If the part number is 30461-000-04 or lower, you must perform the rework procedure below.

(If the card is the correct one it might be convenient, while the card is out, to set jumper B to the position for the XT according to the instructions in **Procedure A**, paragraph A2. Return to Step C3 below when the jumper is set and the card is returned to its slot.)

For future reference, mark here the situation found and action taken:

The correct card was already installed (30461-000-05 or up)

The rework procedure below was performed.

Rework Procedure For Card #6

Refer to the assembly drawing in the **Optimod Operating Manual** (not this manual) for locations of referenced parts.

To save time and avert errors, we suggest that you "walk through" all steps in this procedure with card in hand before beginning work.

C2.a) Using the vacuum desoldering tool, remove all the solder from both sides of the foil pad associated with the center terminal of toggle switch S602. Using fairly strong diagonal cutters, gently clip the center leg of S602, leaving a stub on the switch long enough to later solder two wires (1/8" will do). Remove and discard the portion of the leg formerly soldered to the card. Gentle wiggling with chain-nose pliers may help release it.

C2.b) Using a low-wattage soldering iron, install a glass 1N4148 diode from the Retrofit Kit between the stub and the pad. The banded end of the diode (cathode) goes to the pad. Solder the diode at the pad, but not yet at the stub. (Another wire will be connected to the stub.)

C2.c) Using the vacuum desoldering tool, desolder the non-banded end (anode) of glass diode CR603. (CR603 is near the card edge connector.) Bend the diode upward so that the free end is pointing toward S602. Using the long wire from the kit, connect the free end of CR603 to the center terminal of S602 where the anode of the other diode is already connected. Solder both diodes artfully, avoiding excessive heating and an excess of solder or flux which could creep into the switch.

[These steps have made a node available with which the HF Limiters (on Card #6) and the soft clippers (on Cards #8/9) can be defeated when the XT is plugged into the main chassis.]

C2.d) Referring to the assembly drawing in the **Optimod Operating Manual**, locate and mark pins J and S on the edge connector. Note that not all letters are used: G, I, O, and Q are missing. Pin J is the eighth pin from the top; pin S is the fifteenth.

These pins are fed by traces on the component side of the card. On the component side of the card, using a sharp x-acto knife or equal, cut both of these traces as close as convenient to the pads, near the card edge. Remove about 1/8" of each trace to avoid possible shorts.

(This defeats unused nodes TP2 and TP4 shown on the schematic drawing, and frees pins J and S for use in the next step.)

C2.e) Referring to Fig. 2-3 below, and working on the solder side of the card, install one end of each of the two short jumpers in the kit to the pads connected to pins J and S.

Connect the other ends to the pads shown on Fig. 2-3. Because these pads are so small, there is a risk of shorts. After soldering, it would be wise to remove all flux with a cotton swab moistened with flux remover (Energine Fireproof Spot Remover works well) and to examine the area for solder slivers.

Now, on the component side of the card, reset the two jumper links so that they each contact only one pin. This is a "storage" mode, retaining the links so that they can restore the card to its normal configuration should this be necessary in the future.

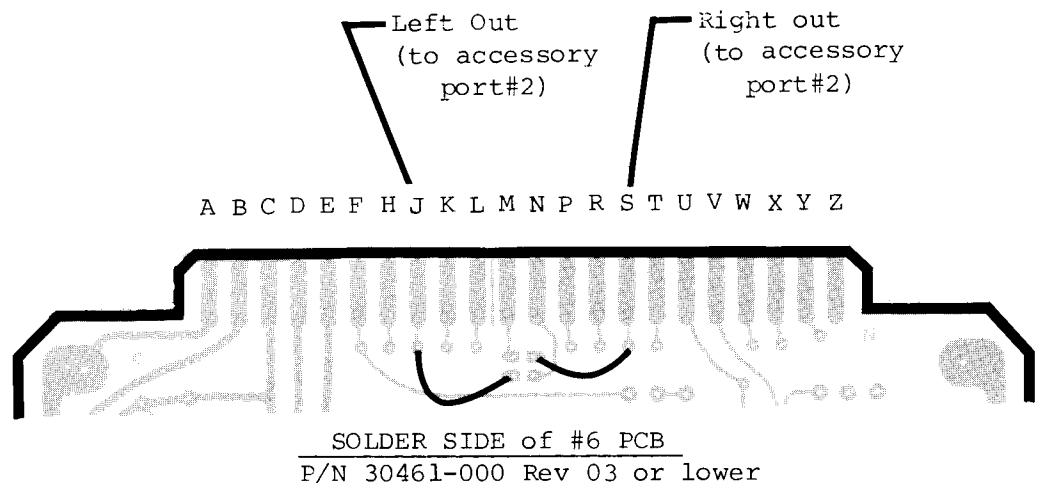

Fig. 2-3: CARD #6 REWORK

C2.f) Carefully recheck all work on Card #6 from Step C2.a on.

[Steps C2.d and C2.e have diverted the outputs of Card #6 to Accessory Port #2 for delivery to the XT.]

If normal operation of the unit (without the XT) is desired in the future, it is only necessary to restore the two jumpers mentioned in Step C2.e to the position shown on the assembly drawing in **Appendix J** of the **Optimod Operating Manual** (thus reconnecting the outputs to Cards #8/9). Note that the XT must be unplugged from the main chassis in this case.

C3) Remove Cards #8 and #9 and examine the solder side.

If the part number etched on the cards (both should be identical) is 30481-000-04 or up, the cards you have are the correct ones for use with the XT.

If the part number etched on the cards is 30481-000-03 or lower, you must perform the rework procedure below on both cards.

[If they are the correct ones it might be convenient, while the cards are out, to set jumper B on each card to the position for the XT according to the instructions in **Procedure A**, paragraph A3. Return to Step C4 below when the jumpers are set and the cards are returned to their slots.]

For future reference, note here the situation found and the action taken:

[] The correct cards were already installed (30481-000-04 or up)

[] The rework procedure below was performed on both cards.

Rework Procedure For Cards #8 and #9

Refer to the assembly drawing in your **Optimod Operating Manual** (not this manual) for locations of referenced parts.

To save time and avert errors, we suggest that you "walk through" all steps of this procedure with a card in hand before beginning work.

C3.a) Using the vacuum desoldering tool, desolder and lift those leads of R804 and R805 which are closest to the card's upper edge. Do not desolder the opposite ends. After the leads have been freed by bending the resistors upward, clear the holes of solder for possible future use.

The two resistors should be positioned so that the free leads cannot accidentally come in contact with other circuits or with each other. A small piece of tape over the holes may be helpful.

C3.b) Carefully recheck all work on Cards #8 and #9 from Step C3.a.

[Step C3.a has disconnected the input of each distortion-cancel lowpass filter from other circuitry. These inputs will now be driven from the XT through Accessory Port #2 (which is connected to TP2 on each of the two cards)].

If normal operation (without the XT) is desired in the future, these resistors are reconnected.

This completes rework operations for Cards #8 and #9. You may reinstall the cards in their slots.

C4) Once the Retrofit Kit has been permanently installed and the cards modified, affix the "Special Modifications" label (included in the kit) to the rear panel of the main chassis near the serial label for future reference.

C5) If, in Step C1, you found that the #5 Card supplied with the Retrofit Kit was a duplicate of one already in your unit, you may wish to return it to the factory for credit against the price paid for the Retrofit Kit.

To do this, contact Orban Customer Service at one of the numbers at the front of this manual to get a Return Authorization (RA) number. We will need the serial number of your unit and the six-digit serial number (if present) stamped on the card itself.

Upon receipt of your duplicate #5 Card, we will mail a refund to the organization represented as the owner on the Registration Card. If the Registration card is not on file, other proof of ownership will be required.

Only the #5 Card included with the Retrofit Kit (not the one that was already in your unit) will be accepted for credit.

The duplicate Card must be returned to us within 60 days of the date of its shipment to you.

Proceed now to **Procedure D** to complete the installation.

PROCEDURE D Final Operations, All Versions

D1) Reinstall the subpanel and close the front panel.

D2) Mount the main chassis in a suitable rack position immediately above the XT.

D3) Connect the XT to the main chassis by plugging the flat cable from the XT into the connector in Accessory Port #2 of the main chassis.

This completes the installation.

PART 3:

Set-up

GENERAL Setup of the Model 8100A/XT Six-Band Limiter Accessory Chassis ("XT") is quite easy. It involves setting the operating controls on the Main Chassis according to a specified pattern, and then setting controls on the XT according to your taste and the requirements of your format.

ADJUSTMENT OF THE MAIN CHASSIS CONTROLS [NOTE: In an installation which uses the Model 8100A/ST Studio Accessory Chassis, most of the "Main Chassis" operating controls are in fact found in the 8100A/ST. However, the adjustment procedure is independent of where the specified controls are located in a given installation.]

Adjust the Main Chassis (or Studio Chassis) operating controls as follows:

INPUT ATTEN (L and R) Adjust to produce approximately 10dB G/R on the MASTER TOTAL G/R meter with the console VU meters peaking normally. Set both controls identically for the time being; final channel balance can be performed later by feeding the L and R inputs with mono material and adjusting either INPUT ATTEN to null the VU meter in its L-R position.

CLIPPING: 0

BASS COUPLING: 10

HF LIMITING 5
[NOTE: The HF Limiter (in the Main Chassis) is inactive when the XT is plugged in. Instead, the HF limiting function is provided by the Six-Band Limiter. Consequently, this setting is non-critical.]

COMPRESSOR PR/OP: "OPERATE"

LIMITER PR/OP: "OPERATE"

GATE THRESH: To prevent noise from being pumped-up during pauses. "0" is recommended for most pop music formats. [NOTE: If you observe a problem with noise being pumped up during very long pauses in material like classical music or radio drama, refer to **Appendix H** in this Manual for a modification which changes the nominal G/R during gating from 0dB to -10dB.]

RELEASE TIME: "8" is recommended. This control determines the release time of the wideband "gain-riding" function, which should be slow for most unobtrusive action. Fast release times are not necessary to achieve high loudness; proper use of the Six-Band Limiter in the XT is a much more effective way to reach this goal.

ADJUSTMENT OF THE 8100A/XT CONTROLS

The operating controls on the XT allow you to trade-off loudness, brightness, and distortion. As with any processor, increasing loudness will result in higher distortion and/or decreases in the amount of brightness obtainable (because of the limitations of the FM preemphasis curve).

When adjusting the XT, it is important to consider the density produced by the processing. The density is defined as the amount of short-term dynamic range: Highly dense program material produces a "wall-of-sound" effect, while less dense program material is more open and less uniformly loud. Almost any processor will increase density to some extent; density increase is the primary means used to increase loudness.

The Six-Band Limiter is capable of increasing the density much more than the basic processing in a "stock" 8100A before overtly objectionable side-effects, like pumping or modulation of one part of the frequency spectrum by program material elsewhere, become audible. However, the ability to increase density radically without overt side-effects can cause problems if exercised carelessly, because excess density, even in the absence of overt side-effects, can be fatiguing. Even though it may be tempting to drive the XT's processing extremely hard because of the loudness increases which can be obtained, some restraint is advisable to avoid long-term listener fatigue.

- 1) **BASS EQ (L and R):** Determines the amount of bass boost, variable from 0 to +10dB. Center frequency is 80Hz, and "Q" is 1.4 (approximately 1 octave).

Adjustment of the Bass EQ controls must be determined by individual taste and by the requirements of the format in use. Some bass EQ is almost always required to audibly balance the effect of the dynamic high frequency boost which the Six-Band Limiter provides on all but very bright-sounding program material. We recommend +4 to +5dB of boost for most formats.

It is important to remember that a strong upper-bass dashboard resonance exists in many cars. Although the XT's Bass Equalizer is tuned well below the frequency where this effect is most pronounced, it is nevertheless possible to create a very muddy sound in certain cars by over-equalizing bass. Be careful!

Also please note that the amount of bass boost is limited dynamically by the Multiband Distortion-Cancelling Clipper and Six-Band Limiter to avoid creating excessive IM distortion in the clippers in the Main Chassis. Therefore, the Bass Equalizer may not have as much audible effect as you would expect, particularly if you are attempting to produce large amounts of boost.

- 2) **DENSITY:** Determines how hard the Six-Band Limiter section is driven, and therefore how much this section will increase the density (i.e., short-term average power) and loudness of the signal.

The control has a 20dB range.

The gain reduction in the Six-Band Limiter is determined by the setting of this control, and by the CLIPPING control. The unit has been designed to sound best when the DENSITY control is adjusted to produce no more than 10dB G/R in the two middle bands. The top bands may safely exhibit much more G/R, particularly with bright program material and with large amounts of HF EQ.

- 3) **CLIPPING:** Determines how hard the Multiband Distortion-Cancelled Clipper and FCS Overshoot Compensator are driven, and therefore how much peak control is achieved by clipping. The range of the control is -4 to +2dB. We believe "0dB" to be an effective compromise between loudness and distortion for most highly-competitive pop music formats.

The loudness/distortion tradeoff is primarily determined by this control.

However, for a given setting of the CLIPPING control, perceived clipping distortion will increase as the DENSITY control is advanced, and the CLIPPING control may have to be turned down (CCW) to compensate.

The CLIPPING control is a threshold control for all bands in the Six-Band Limiter. Therefore, as the CLIPPING control is turned down (counterclockwise), the threshold of the Six-Band Limiter is lowered and more gain reduction occurs, decreasing average levels into the clippers.

This control affects both L and R simultaneously.

PUTTING THE SYSTEM ON THE AIR

Cautions: Particularly if you have converted an 8100A to accept the XT, it is important to be sensitive to signs of incorrect operation of the system, which could occur as a result of wiring errors or other faults in the conversion. Full instructions for verifying the installation by instrument are supplied in **Appendix D (Field Audit-Of-Performance Procedure)**. However, as you perform the setup, be aware of the following symptoms which could indicate incorrect installation:

- 1) Sibilance Distortion can indicate that the XT is not correctly connected to the distortion-cancelling lowpass filter of the channel with the fault.
- 2) Muffled sound with extremely poor high frequency response can indicate that the connections to the main and distortion-cancelling lowpass filters have been reversed.
- 3) If the HF Limiting lamps on the Main Chassis light at any time, this could indicate a problem with the modifications to Card #6, as this indicates that the HF Limiter on Card #6 has not been forced into PROOF mode by the XT's being plugged into the Main Chassis. (Although very improbable, it could also indicate that the wrong-revision #6 Card was supplied in an 8100A/1 due to factory error. The correct card should have an assembly number whose last digits are -05 or above. A -04 card will not work, and can cause this symptom.)

If any of these problems are observed, first review your work, referring to **Part 2 (Installation)**. If you do not find the problem upon visual inspection, refer to **Appendix D** for more complete diagnostic tests.

Matching To The Exciter: If you have adjusted the Main Chassis and XT according to our recommended initial settings, you are almost ready to put the system on the air.

If you have installed the XT in an 8100A system which was already up and running, no adjustment of the stereo generator setup controls or OUTPUT ATTN control is ordinarily required upon reinstallation. In this case, please skip to **Program Tests** below.

If the Main Chassis was not previously installed in the station, it must be matched to the exciter according to instructions in **New Installations** immediately below.

New Installations: In a new installation, the OUTPUT ATTEN on the Main Chassis must be adjusted to achieve correct modulation levels. Apply normal program material to the system input, and verify that the G/R meters on the Main Chassis and XT are moving in the approximate range of 5-15dB G/R. (This is highly dependent upon the settings of the Main Chassis INPUT ATTEN controls and upon the settings of the XT's DENSITY and CLIPPING controls.)

Turn the OUTPUT ATTEN control fully counterclockwise. (This may take up to 15 turns.)

Turn on the transmitter, and advance the Main Chassis OUTPUT ATTEN until 99% modulation is observed on your monitor. Check your stereo monitor to make sure that pilot injection is between 8-10%. If it is not, adjust the PILOT INJECTION control on the Main Chassis to secure 9% injection.

As shipped from the factory, the Main Chassis stereo generator setup controls (PILOT PHASE, PILOT INJECTION, AND SEPARATION) are adjusted to produce an "ideal" stereo output. If you have a modern high-performance exciter and connect it to the Main Chassis through cable less than 4 feet (1.2m) long, your installation will probably meet FCC stereo performance requirements by a comfortable margin without further adjustment of these controls. Nevertheless, you should perform a stereo proof of compliance with FCC 73.322 (as described beginning on p. 6-1 of your **Optimod Operating Manual**) soon after installation to verify that your installation is operating legally.

Program Tests: At this point, you should proceed with initial program tests. Be sensitive to audible problems with audio quality, including excessive noise, RF pickup, etc. We advise performing a Proof-Of-Performance by instrument as soon as practical after your installation to verify that all is well. Instructions of performing such a Proof are found in **Part 4** of this Manual.

After you have verified that the installation is operating properly, you can proceed to adjust the operating controls according to your taste and the requirements of your format. Refer to **Adjustment Of The Main Chassis Operating Controls** and **Description And Adjustment Of The Accessory Chassis Operating Controls** above in this **Part** to guide your adjustments.

Realignment For Absolute Maximum Loudness

Theory: In order to control peak levels without introducing significant components above 19kHz into its output spectrum, the FCS Overshoot Compensator introduces a peak level uncertainty of approximately 0.7dB into the audio waveform driving the stereo generator. A safety clipper following the FCS Overshoot Compensator is factory-aligned to operate only on the most unusual waveforms: for a vast majority of program material, it never operates.

However, if the safety clipper is driven approximately 1dB harder, then it, not the FCS circuit, controls the final peak level. The safety clipper introduces no peak level uncertainty, but its action introduces substantial energy above 19kHz which can cause aliasing distortion (loss of dynamic separation and dynamic non-linear main-channel to subchannel crosstalk). However, 1dB higher loudness is achieved. This compromise is similar to the compromises introduced by composite clipping (although without pilot modulation), and is therefore not recommended except for the most competitive situations, as quality will suffer.

Realignment Procedure:

- 1) Obtain access to the circuit cards in the Main Chassis, following the instructions in **Appendix C (User Access)** of your **Optimod Operating Manual**.
- 2) Extend Card #8, using the extender card stored in the far left-hand slot of the card cage. Referring to the Card #8/9 Assembly Drawing in **Appendix J** of the **Optimod Operating Manual**, locate trimmer control R841 (SAFETY CLIPPER THRESH). Using a pencil, mark the current setting of the control for later restoration, if desired.
- 3) Apply a 1kHz tone to the Left Input of the system at a level sufficient to cause some gain reduction. Adjust R841 clockwise until the system output level (as measured on your modulation monitor or at the Main Chassis rear-panel TEST JACK) increases by 1.0dB. (Going further than 1.0dB is likely to produce decidedly objectionable distortion.)
- 4) Repeat steps (2) and (3) for the right channel, adjusting Card #9.
- 5) This concludes the realignment. Reassemble the unit. If you decide that you do not like the results, you can simply reset the trimmer controls to the pencil marks. [If you lose these marks, or doubt their validity, R841 can be restored to its "standard" setting by following the instructions under **Cards #8 and #9** in **Appendix E (Field Alignment Procedure)**]

This concludes **Part 3 (Setup)**.

PART 4: Proof-of-Performance

Doing a Proof-Of-Performance with the XT in use is very similar to doing a Proof with a "stock" 8100A.

It would be wise, for future reference, to annotate your **Optimod Operating Manual** at the beginning of **Part 6** with the words:

For Proof with the Model 8100A/XT Six-Band Limiter Accessory Chassis or the Model 8100A/ST Studio Accessory Chassis installed, please see additional information in the manuals provided with these units.

- 1) Place the XT's PROOF/OPERATE switch in PROOF.
- 2) Note the positions of the two BASS EQ controls and of the DENSITY control.
- 3) Turn both BASS EQ controls and the DENSITY control fully counterclockwise. (This makes the frequency response of the XT flat and optimizes system signal-to-noise ratio.)
- 4) Perform the Proof-Of-Performance (mono) and/or Stereo Proof-Of-Compliance With FCC 73.322 by following the instructions in **Part 6 (Proof-Of-Performance)** of your **Optimod Operating Manual**. Provided that you have followed the instructions in steps (1-3) above, the XT acts as a flat amplifier in the signal path of the Main Chassis. Thus a Proof can be performed exactly as specified in **Part 6**. (In PROOF mode, all active elements remain in the signal path.) While measured performance will not be as good as that of an 8100A alone (because of the extra crossovers and VCA's introduced in the signal path by the XT), performance will still greatly exceed FCC requirements. Compliance with the specified preemphasis curve will exceed $\pm 1.0\text{dB}$, noise will typically be -70dB below 100% modulation, and THD will be less than 0.1%. Sufficient headroom has been provided to modulate above 100% at all frequencies.
- 5) When you are finished, return the XT's PROOF/OPERATE switch to OPERATE, and return the controls changed in step (3) above to their original settings.

APPENDIX A: System Description

This **Appendix** is complementary to **Appendix A** in your **Optimod Operating Manual**, and refers to that document. The **Appendix** within this Manual refers only to those parts of the circuitry within the XT, and how that circuitry relates to the Main Chassis.

1) Main Chassis HF Limiter And Main Clipper Defeat:

The signal is applied in preemphasized form to the XT from the output of the HF limiter in the Main Chassis. Whenever the XT is plugged into the Main Chassis, this HF limiter is forced into PROOF mode by a jumper within the XT's plug which completes a connection between the Main Chassis' +15V power supply and its Limiter Proof Bus, defeating the main clippers on Cards #8 and #9 in addition to the HF limiter. The +4.1V supply on Card #6 of the Main Chassis (which activates the FCS Overshoot Compensator and safety clipper within the Main Chassis) is isolated from this jumper by means of a diode, and still remains operational unless the LIMITER PROOF/OPERATE switch in the Main Chassis is placed in PROOF.

2) Bass Equalizer: [on Card #A1]

The input signal to the XT is first applied to a Bass Equalizer. This produces a peaking boost (i.e., bell-shaped curve) with a center frequency of 80Hz, a "Q" of 1.4, and a boost variable from 0 to +10dB.

Boost is produced by subtracting the output of an inverting second-order bandpass filter from the main signal, producing an overall addition.

3) Six-Band Limiter And Distortion-Cancelled Multiband Clipper (General)

The six-band limiter is so intimately integrated within the multiband clipper that the two functions must be considered as one.

The signal from the Bass Equalizer is first divided into six frequency bands by a pre-limiter crossover filter. Each crossover filter drives its own limiter. The outputs of all limiters except 1.6kHz drive individual clippers followed by post-limiter filters. (The characteristics of the pre- and post-limiter filters are such that the final summation of the bands can be made to be very flat -- better than ± 0.5 dB.)

These 6dB/octave post-limiter filters following the clippers provide first-order reduction of clipper-induced distortion. The first-order filtered distortion induced by clipping in the upper two bands is derived by subtracting each clipper's output from its input and then filtering this distortion signal with a filter identical to the post-crossover filter. The sum of these filtered distortion signals from the upper four bands is passed through a 2.2kHz lowpass filter.

Meanwhile, the clipped, filtered sum of all of the bands is passed through a phase-corrected 15kHz filter whose delay matches that of the 2.2kHz lowpass filter. (The 2.2kHz and 15kHz filters are located on Card #8/#9 in the Main Chassis.) The outputs of the 15kHz and 2.2kHz filters are summed, sharply cancelling clipper-induced distortion below 2.2kHz (the "flat" part of the FM preemphasis curve.)

It should be noted that it is normal for sinewaves to modulate less than 100% when applied to the system in its normal OPERATE mode. There are two principal reasons for this:

- 1) Some headroom is left between the threshold of the Multiband Distortion-Cancelled Clipper and the threshold of the subsequent FCS Overshoot Corrector in order to accommodate the distortion corrector signal. With sinewaves, no distortion corrector signal is produced. Thus, the headroom is not used, and full 100% modulation does not occur.
- 2) Sinewaves have a very low peak-to-average ratio and high loudness potential compared to program material of identical peak levels. The audio processing, in order to maintain natural sound quality, pushes sinewaves down in level as it would any other similar program material with low peak-to-average ratio. In general, any audio processor which produces 100% modulation on sinewaves tends to sound somewhat unnatural because this psychoacoustic factor has not been accounted for.

(NOTE: This system is protected by U.S. Patent #4,412,100.)

3.a) Pre-Limiter Crossovers: [on Card #A1]

The crossovers are realized as follows:

- 1) 150Hz lowpass Second-order 420Hz lowpass filter cascaded with second-order 150Hz lowpass filter
- 2) 420Hz bandpass Second-order 420Hz lowpass filter cascaded with third-order 420Hz highpass filter
- 3) 700Hz bandpass Second-order lowpass filter cascaded with third-order highpass filter
- 4) 1.6kHz bandpass Two second-order stagger-tuned bandpass filters cascaded
- 5) 3.7kHz bandpass as above
- 6) 6.2kHz highpass Second-order 6.2kHz highpass filter

Bands 3-6 are fed from a first-order allpass filter which provides phase correction for the crossover summation.

3.b) Voltage-Controlled Amplifier (VCA) Operation: [on Card #A3]

The voltage-controlled gain block used throughout the XT is a proprietary Class-A VCA which operates as a two-quadrant analog divider with gain inversely proportional to a current injected into the gain-control port. A specially-graded Orban IC contains two matched non-linear gain-control blocks with differential inputs and current outputs. The first of these is employed in the feedback loop of an opamp to perform the gain control function. The inputs of the first and second gain-control blocks are connected in parallel, and the output of the second block is a distortion-corrected current which is transformed into the desired gain-controlled voltage by means of an opamp current-to-voltage converter.

3.c) Six-Band Limiter Control Circuitry: [on Card #A2]

The output of each band VCA feeds a voltage divider which, in turn, feeds a dual comparator IC. If the output of the voltage divider exceeds a positive or negative threshold set by the CLIPPING control (0.5 to 1.0V), the comparator will produce an output pulse which is smoothed by the timing module, producing a control voltage which reduces the gain of the VCA. The drive to the clippers following the compressors and preemphasis/high-frequency limiters is thus determined by the setting of the CLIPPING control, which simultaneously adjusts all comparator thresholds (and thus the average VCA output level).

This timing circuitry is proprietary, and is located within sealed modules.

The timing circuits process the signal in logarithmic form, and have low-impedance outputs. These drive exponential converters which provide control-current outputs for their respective VCA's.

The DENSITY control provides a DC control voltage which offsets the logging transistors in the reference logarithmic converters in the VCA's. This control voltage can vary the gains of all VCA's by as much as 20dB while maintaining extremely accurate tracking. Thus left and right channels remain correctly balanced.

3.d) Post-Limiter Crossover, Clippers, and Distortion-Cancellation System: [on Card #A1]

The upper two bands (3.7kHz and 6.2kHz) are treated differently than the bottom three bands (150Hz, 420Hz, and 700Hz). [The remaining band (1.6kHz) is unique in that it is not followed by a clipper.]

Difference-frequency IM due to clipping is cancelled below 2.2kHz by means of a feedforward distortion-cancelling sidechain (U.S. patent #4,412,100). The output of each of the two upper bands is applied to two identical filters (one inverting and one non-inverting) with 6dB/octave slopes. The 6.2kHz band filter is highpass; the 3.7kHz band filter is bandpass.

A clipper is located before the inverting filter, so that the inverting filter filters the clipped signal, somewhat reducing out-of-band clipper-induced distortion.

The outputs of the inverting and non-inverting filters are added in the distortion-cancel summing amplifiers. If no clipping occurs, the outputs of the inverting and non-inverting filters will cancel, and no output will be produced by the distortion-cancel summing amplifiers. If clipping does occur, then the output of the distortion-cancelled summing amplifiers will represent the difference between the clipper's input and output as filtered by the inverting filter: i.e., the distortion added by the clipper, as filtered through the inverting filter.

Since the upper two bands are all handled by the distortion-cancel summing amp, the output of this amplifier represents the sum of the filtered clipper-induced distortion produced by the two clippers in these bands. This signal is applied to the distortion-cancel filter: a 2.2kHz lowpass filter with constant delay.

Meanwhile, the outputs of the inverting filters alone (containing the clipped, filtered outputs of the upper two bands) are summed into the band summation amplifier. The output of this amplifier is applied to the input of the 15kHz phase-linear lowpass filter.

The outputs of the 15kHz filter and 2.2kHz filter are summed. Considering for a moment the case where only one band is passing signal, the clipper-induced distortion component contributed by this band to the 2.2kHz filter's output is equal to, and out-of-phase with, the same distortion component in the 15kHz filter's output. Thus, this distortion component is cancelled by better than 30dB within the 2.2kHz bandwidth of the distortion-cancel filter. Because both the 15kHz and 2.2kHz filters are linear, as is the summation process, superposition holds, and the distortion component in each of the two top bands is cancelled even when more than one band is active.

The three low frequency bands are not treated by the distortion-cancellation sidechain: Simple lowpass filtering of the clipped signal is employed for distortion reduction.

The output of the 150Hz band is clipped and then applied to a pair of cascaded 6dB/octave lowpass filters before it is summed with the rest of the bands in the band summation amplifier. A clipper is located between the first and second of these filters. The output of the 420Hz band is applied to this clipper, and then through the second lowpass filter to the band summation amplifier. The clipper thus clips the sum of the 420Hz band and the clipped, filtered 150Hz band.

The output of the 700Hz band is clipped independently of the two lower bands. The output of the 700Hz clipper is lowpass filtered at 6dB/octave and summed into the band summation amplifier.

APPENDIX B: Circuit Description

This **Appendix** is complementary to **Appendix B** in your **Optimod Operating Manual**, and refers to that document. The **Appendix** within this Manual refers only to those parts of the circuitry within the XT, and how that circuitry relates to the Main Chassis.

Since this **Appendix** contains an extremely detailed description of the XT circuitry at the component level, it is wise before using this **Appendix** to first review **Appendix A**, which provides a more general overview.

Whenever circuitry is duplicated for the left and right stereo channels, the left channel will be described.

1) Main Chassis HF Limiter And Main Clipper Defeat:

This was fully discussed in **Appendix A**. Further information about the HF limiter and main clipper can be found in your **Optimod Operating Manual**.

2) Bass Equalizer: [on Card #A1]

A bell-shaped bass boost is achieved by subtracting (in IC19b) the output of inverting bandpass filter IC19a and associated components from the filter's input. (Note that IC19b is inverting for the main signal and non-inverting for the output of IC19a.)

For a discussion of the inverting bandpass filter, see for example -- Wong and Ott: Function Circuits. McGraw-Hill, New York, 1976, chapter 6.

If the equalizer fails, first check IC1. If this fails to correct the problem, the passive components R70, R71, R73, C23, C24 must be checked on an impedance bridge.

3.a) Pre-Compressor Crossovers: [on Card #A1]

Little need be said about these filters which has not been stated already in **Appendix A**. All filters are built with second-order sections of the type found in any modern text on active filter design (see for example--Wong and Ott, op. cit.). Some filters are of the "multiple feedback" type, and are basically negative-feedback filters. Others are of the "Sallen and Key" type, and are positive feedback filters. The two types are mixed as necessary to achieve desired inverting (negative feedback) or non-inverting (positive feedback) responses.

3.b) Voltage-Controlled Amplifier (VCA) Operation: [on Card #A3]

NOTE

This section contains a general description of the Voltage-Controlled Amplifier circuitry used throughout the XT. Band 1 will be specifically described.

The basic operation of the VCA depends on a precisely-matched pair of gain-control blocks with differential voltage inputs and current-source outputs. The gain of each block is controlled by means of a control current.

If used alone, one such gain-control block would introduce considerable distortion. Therefore, the first of the two matched blocks (IC13a) is used as the feedback element in an operational amplifier, IC1a. The second of the matched blocks (IC13b) is then driven by the predistorted output of IC1a. To provide more detail: The output of IC1a is first attenuated by R4, R5 and then applied to the input of the feedback element IC13a. The output of IC1a is predistorted as necessary to force the current output of IC13a to precisely and linearly cancel the audio input into the "virtual ground" summing junction of IC1a. This same predistorted voltage is also connected to the input of IC13b. Thus the output of IC13b is an undistorted current, which is converted to a voltage in current-to-voltage converter IC1b, R9, R10, C1, C2. The output of IC1b is the output of the VCA.

Because IC13a is in the feedback loop of IC1a, the gain of the VCA is inversely proportional to the gain of IC13a. Thus if the control current is applied to the control port of IC13a (through R11), then the VCA behaves like a two-quadrant analog divider.

A fixed current is applied to the control port of IC13b through R8 to set the gain of IC13b. R8 is fed by a +1.2V source common to all VCA's on a card: R85, CR4, CR5. The diodes provide temperature compensation.

Second-harmonic distortion is introduced by differential offsets in either IC13a or IC13b. This distortion is cancelled by applying a nulling voltage directly to the input of IC13b by means of resistor network R3b, R6, R7.

If the VCA is not perfectly balanced, "thumps" due to control current feedthrough can appear at the output. These are equivalent to multiplying the control current by DC. If a correct DC offset is applied to the VCA input, then this equivalent DC multiplication can be nulled to zero and the "thumps" eliminated. Such an adjustable DC offset is provided by R3a, R2.

The basic current-controlled gain in the compressor/limiter is inversely proportional to the control current. This must be transformed into a gain which is proportional to a control voltage in dB. This is done in the exponential current converter consisting of IC25a and associated components.

IC29a, IC29d, and associated components form a log/antilog multiplier which multiplies the current flowing in R88 by the exponential of the voltage on the base of IC29a. The current gain of the multiplier increases as the voltage on the base of IC29a becomes more positive.

The exponential converter transistors for all of the VCA's in a given group of bands (1-3 or 4-6) are located within a monolithic array. IC29 serves this purpose for bands 1-3. One transistor within this array (IC29d) is dedicated to providing a reference for all of the exponential converters. The emitters of all the exponential converter transistors are connected to this common source.

This reference (approximately -0.6V) is produced by forcing a constant current through IC29d. The voltage across R88 is held at 15 volts by the feedback action of IC26a, determining the current through IC29e and thus its base-to-emitter voltage. C22 prevents IC26a from oscillating, and IC29c protects IC29d from a reverse bias latchup condition.

The output current of the log/antilog multiplier appears on the collector of IC29a. It is the wrong polarity and level to correctly drive the control-current port of IC13a. It is therefore applied to a current inverter IC25a, Q1, R13, R14, C3. This circuit has a gain of 6.66x, and operates as follows:

A voltage proportional to the current output of IC29a is developed across R14 because of the feedback action of IC25a. (C3 stabilizes IC25a against oscillations.) Feedback forces IC25a's (-) and (+) inputs to be at the same voltage. Thus, the same voltage which appears across R14 also appears across R13, and current flows in R13 in proportion to the ratio between the values of R14 and R13.

This current flows out of the (+) input line of IC25a into the emitter of Q1. Because Q1's base current is small compared to its emitter current, essentially the same current flows out of Q1's collector into the gain-control port of IC13a.

The base of Q1 is grounded; its emitter therefore sits at +0.6V. This forces both (+) and (-) inputs of IC25a to also sit at +0.6V.

CR1 protects Q1 from reverse base-emitter voltage which could otherwise cause junction breakdown and latchup of the entire current-inverter circuit.

3.c) Six-Band Limiter Control Circuitry: [on Card #A2]

Except for component values, the control circuits for all six bands are identical. We will discuss the control circuit for Band 1 (150Hz) in detail.

The output of the Band 1 VCA is applied to voltage divider R1, R2 which protects IC1, a 711 dual comparator, from being driven beyond its ratings. IC1 produces a positive-going pulse of approximately +4.5V if the output of voltage divider R1, R2 exceeds the comparator threshold voltage generated by IC12 (on Card #A1) and associated circuitry. The threshold of limiting is thus determined by two factors: (1) the loss in voltage divider R1, R2 (the more loss, the higher the voltage at the VCA output before IC1 turns on); and, (2) the threshold voltage applied to IC1. This voltage is varied from ± 0.5 to ± 1.0 V by means of CLIPPING control R160 (on Card #A1), varying the threshold of limiting (and thus the average output level of the band VCA's) by feedback.

The output of IC1 is applied to a unity-gain inverter and level shifter Q1, R5, R7. The waveform at the collector of Q1 consists of pulses which go 4.5V below the +12V collector supply voltage. These pulses develop approximately 4V across R6, the emitter resistor of Q2. The current which flows through R6 is essentially identical to that flowing from the collector of Q2 into the timing module. The value of R6 scales this current, determining the attack time.

The timing module integrates this current and produces a voltage which is buffered by unity-gain FET-input opamp IC3a. The output of IC3a is a dB-linear control voltage which determines the gain of the band VCA (in dB).

3.d) Post-Compressor Crossover, Clippers, and Distortion-Cancellation System: [on Card #A1]

(The reader is strongly advised to read the discussion of this part of the circuitry in **Appendix A** before embarking on the following description, as the two descriptions complement each other.)

The distortion-cancellation system works identically on Bands 5 and 6. We will use Band 5 (3.7kHz) as a typical "high frequency" band for purposes of discussion.

The output of the band VCA is applied to the upper 6dB/octave bandpass filter R16, R17, C6, C7. Clipper diodes CR7, CR8 are embedded between R16 and R17 and clip the output of the band VCA before it is applied to the bandpass filter. The clipped, bandpassed signal is summed into IC1b (the band summing amplifier) through R18, and into sidechain summing amplifier IC3a through R19. The output of the band VCA is also applied to a lower bandpass filter R24, C8, C9. The frequency response of this filter is identical to the frequency response the filter associated with CR7 and CR8.

The output of lower bandpass filter is summed through R25 into IC3b. The output of IC3a (containing the inverted contribution of the upper bandpass filter) is summed through R21 into IC3b. When clippers CR7 and CR8 are non-conductive, total cancellation (within the limitation of component tolerances) therefore occurs because the upper and lower filters are identical, and their contributions are summed out-of-phase. Thus, no signal appears at the output of sidechain summing amplifier IC3b.

When the clippers conduct, all signal is cancelled at the output of IC3b except for the distortion added by the clipping process, as filtered by the upper bandpass filter.

The output of the Band 1 VCA is clipped by CR1, CR2, lowpass filtered by R2, R3, C1, and then summed with the output of Band 2 in IC1b. The sum is clipped by CR3, CR4, and lowpass filtered again through R6, R7, C2 before being summed into band summing amplifier IC1a.

The output of Band 3 is clipped by CR5, CR6, and lowpass-filtered by R11, R12, C3, before being summed into IC1a.

The output of Band 4 is not clipped, but is simply summed into IC1a through bandpass filter R13, R14, R15, C4, C5.

The output of IC1a feeds the 15kHz lowpass filter on Card #8/9 in the Main Chassis. Meanwhile, the output of distortion-cancel summing amp IC3b feeds the 2.2kHz lowpass filter on Card #8/9 in the Main Chassis. The outputs of these filters are summed, sharply cancelling clipper-induced distortion below 2.2kHz, as described in **Appendix A**.

APPENDIX C: User Access

User access to the XT Chassis is very straightforward.

- ROUTINE ACCESS** a) **User Adjustments:** To access the user adjustments, open the access door using the key furnished. This will reveal all user-adjustable controls.

There are no user adjustments on the circuit cards. To access the circuit cards for service or alignment, see **Service Access** immediately below.

- SERVICE ACCESS** [NOTE: See **General Cautions** on p. C-1 of your **Optimod Operating Manual**.]

- a) **Cover Removal:** Simply remove all screws holding a given cover in place, and remove. This will reveal the circuit cards.

[Cards #A1 (Crossovers and Bass Equalizer) and #A2 (Limiter Control Circuitry) are accessed by removing the top cover, while Card #A3 (VCA's) is accessed by removing the bottom cover.]

- b) **Circuit Cards:** The XT Chassis contains three circuit cards, numbered A1, A2, and A3. If you look at the top of the chassis and orient it such that the meters are on the lower left-hand side, Card #A1 is to the right, and Card #A2 is to the left. Card #A3 is located on the bottom side of the horizontal metal plate which divides the two sections of the chassis.

The circuit cards are not the normal plug-in type used elsewhere in OPTIMOD products. Nevertheless, they are easily removable for servicing.

All cards are mounted on standoffs by means of several #6-32 screws. If you wish to access the bottom of the card for troubleshooting, remove the screws and tilt the cards backwards, being careful not to accidentally short-circuit the metallic traces on the cards to the chassis. To completely remove a card from the chassis, you must also unplug all ribbon cables connected to that card, noting the orientation of the plugs for later reconnection.

When replacing the covers, be sure to replace all screws and secure them tightly to maintain RFI suppression.

APPENDIX D:

Field Audit-of-Performance

This Appendix provides instructions enabling XT users to check the performance of the total system consisting of the XT plus the Main Chassis.

Because the XT circuitry is embedded within the Main Chassis circuitry, it is not practical to test it independently of the Main Chassis in the field. If the 8100A/ST Studio Accessory Chassis is in use and you are certain that the fault is not within the 8100A/ST, it is possible to test only the Main Chassis/XT combination by applying test signals to the input of the Main Chassis, bearing in mind that no Broadband Compression function will be produced since this function resides in the 8100A/ST.

If audio problems develop, many engineers immediately blame their processing. However, as is the case with any processing, faults in the audio equipment preceding OPTIMOD-FM will be magnified by the action of the processing. Program material that is marginally distorted at the OPTIMOD-FM input, for example, is likely to be unlistenable by the time it emerges from the output when aggressive processing is used -- particularly when the XT is employed! In addition, be sensitive to possible defects in the monitoring equipment; verify that a problem can be observed on at least two receivers before pushing the panic button.

This procedure is a starting point for detecting and diagnosing a problem that you have pinpointed to the OPTIMOD-FM system. It is also useful in routine maintenance, and can be used at Proof time to check routine equipment performance, providing more data than the Proof alone provides. By its nature, it is limited in scope to discovering static problems. A dynamic problem in the AGC circuitry (caused by the failure of a timing module on Card #A2, for example) would not tend to be discovered in the course of these tests.

For this reason, measurements must always be complemented by listening. If you are well-acquainted with the "sound" of OPTIMOD-FM as adjusted to your tastes, then faults that develop will ordinarily be readily detectable by ear.

Required Equipment

- a) Audio Oscillator. An ultra-low-distortion type like the Sound Technology 1710B is preferred. However, a Heathkit or Eico-type oscillator (such as Heath IG-72) can be used to obtain approximate results, provided that residual distortion has been verified to be below 0.1%.
- b) Noise and Distortion (N&D) Test Set. Once again, a high-performance type like the Sound Technology is preferred, but not required.
- c) General-Purpose Oscilloscope. DC-coupled, dual-trace, with at least 5MHz vertical bandwidth. This is used to monitor the output of the N&D Test Set.
- d) Pink Noise Generator. A suitable circuit is shown in Fig. D-1.

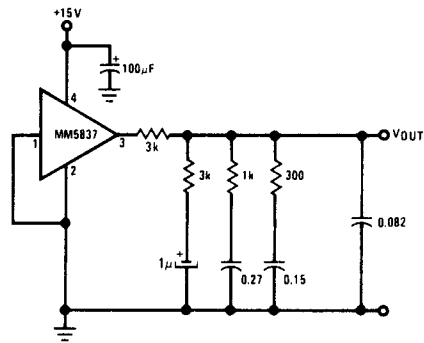

Fig. D-1: Pink Noise Generator
(From National Semiconductor Audio/Radio Handbook)

Audio Processing

It is often more convenient to make measurements on the bench, away from high RF fields which might otherwise affect results. For example, in a high RF field, it is very difficult to accurately measure the very low THD produced by a properly-operating OPTIMOD-FM system at most frequencies. However, in an emergency situation (is there any other kind?!), it is usually possible to do measurements under high-RF conditions which should reveal the grosser faults.

The audio processing can be measured independently of the stereo generator by connecting the measuring instruments to the rear-panel TEST JACKS. The following procedure assumes that all test excitations are applied to the Main Chassis rear-panel main audio input terminals, and that all responses are measured at the Main Chassis TEST JACKS.

- a) **Standard Control Setup:** Record the normal settings of the controls so that they can be reset after the measurements have been completed. Then set the controls as follows:

Main Chassis

L and R Input Attenuators:	0
Clipping:	0
Release Time:	10
Bass Coupling:	10
Gate Threshold:	0
H-F Limiting:	5

Accessory Chassis

Bass EQ (L&R):	0
Density:	0
Clipping:	0

- b) **Skeleton Proof:** This should be performed for both left and right channels.
- 1) Place all PROOF/OPERATE switches in PROOF. (Two switches in the Main Chassis and one switch in the XT.)
 - 2) Connect a low-distortion audio oscillator to the Main Chassis input. Set the frequency to 15kHz, and adjust the oscillator output level to produce 3.3V rms (an internal level corresponding to 100% modulation) at the Main Chassis TEST JACKS. (This is most easily done by adjusting the oscillator output level to make the Main Chassis VU meter read "+3" in the L or R FILTER OUT position, corresponding to the channel which you are testing.)

- 3) Connect the input of the N&D test set to the Main Chassis TEST JACKS through a 75us deemphasis network. (See Fig. D-1 in the **Optimod Operating Manual.**)
- 4) Now measure the frequency response by measuring the oscillator output required to produce 3.3V rms at the TEST JACKS (or to make the VU meter read "+3") at 50, 100, 400, 1000, 5000, 10,000, and 15,000 Hz. To obtain more reliable results, it is advisable to measure the frequency response at several points between the FCC-mandated frequencies provided above. In addition, if you use the AC voltmeter in the N&D Test Set to measure oscillator and/or OPTIMOD-FM output levels, bear in mind that the 75us deemphasis network must not be used for these measurements.
- 5) Since the frequency response test requires you to readjust the oscillator output level at each frequency to produce 100% modulation at the OPTIMOD-FM output, it is often convenient to measure the THD @ 100% modulation at the same time that you measure frequency response. If you are using the the N&D Test Set's AC voltmeter in the frequency response test, remember that you must connect the 75us deemphasis network to the N&D meter input for the THD measurements only.
- 6) Plot the results of the frequency response measurement on a standard 75us (or 50us) preemphasis graph like FCC #73.333 (USA). The points should be within +1.0dB of the standard preemphasis. (See p. D-3 in the **Optimod Operating Manual.**)

Frequency response errors which develop in the field are usually caused by incorrect quiescent VCA gains. The system first breaks the audio into two bands with a crossover at 200Hz. (This occurs in the Main Chassis.) Following preemphasis in the Main Chassis, the signal is divided into six bands in the XT. Any frequency response errors are most likely to be introduced at this point.

The **Block Diagram** in **Appendix J** provides a "road map" through the system. By tracing the signal through the entire system from input to output and measuring the frequency response as you proceed, it is possible to discover which stage introduces the error. (A sweep generator greatly speeds the measurement process.) If the error is not due to a misaligned VCA, then crossover filter failure must be suspected. If the error is due to a misaligned VCA, be aware that there may be drift in the VCA or its associated exponential converter which must be repaired to achieve stable frequency response.

- 7) The deemphasized THD should not exceed 0.15% at any frequency. In many cases, results will be determined entirely by the quality of oscillator and distortion analyzer available, and/or by the presence of RF fields which might affect the instruments.

(A more complete frequency response evaluation can be performed by sweeping the system with a test set like the Tektronix 5L4N Spectrum Analyzer/Tracking Generator. If the station has such equipment, see paragraph 6.c of **Appendix E** in the **Optimod Operating Manual** for further information.)

- 8) **Noise:** Short both OPTIMOD-FM inputs, and measure the deemphasized noise at the OPTIMOD-FM output through the 75us deemphasis network. It should not exceed -53dBm (corresponding to -70dB below 100% modulation). (Note that hum or buzz due to test equipment grounding problems and/or high RF fields may result in falsely high readings. If the output of the N&D set is monitored with a scope, problems like this should be immediately apparent.)
- c) **Operate-Mode Measurements:** These measurements evaluate certain static characteristics of OPTIMOD-FM in its normal OPERATE mode. Typical measurements given herein are provided for service guidance only, and are not guaranteed. As in the PROOF mode measurements above, these measurements should be repeated for both left and right channels.
- 1) Reconnect the audio oscillator to the OPTIMOD-FM input. Switch all three PROOF/OPERATE switches to OPERATE. Be sure that operating controls are standardized as described in (a) above. Set the oscillator frequency to 1kHz, and adjust the oscillator output level to produce 10dB G/R as read on the MASTER G/R meter on the Main Chassis front panel.
 - 2) Adjust the XT DENSITY control as necessary to produce 10dB G/R as indicated on the 700Hz G/R meter. (Major adjustment should not be required.)
 - 3) Measure the output level and THD for each frequency indicated in the table below, and compare your results with the typical readings provided.

Output level should be ± 2 dB of values provided. THD can vary substantially, but should not exceed 0.5% at any frequency. THD is highly dependent on the setting of the CLIPPING control on the XT because this control can move the sinewave level above or below the thresholds of the clippers associated with the various bands.

<u>FREQUENCY (HZ)</u>	<u>THD (%)</u>	<u>OUTPUT (V_{rms})</u>
50Hz	0.25%	0.78V
100Hz	0.25%	1.05V
400Hz	0.08%	0.91V
1kHz	0.08%	0.93V
2.5kHz	0.08%	1.15V
5kHz	0.06%	1.20V
7.5kHz	0.10%	1.08V
10kHz	0.15%	1.05V
15kHz	0.25%	1.00V

Table D-1

OPERATE-MODE THD AND OUTPUT LEVEL

- 4) **Pink Noise Tests:** Connect a pink noise generator to the OPTIMOD-FM L input. Advance its output level until the Main Chassis Broadband G/R meter reads "-10". Do not change any settings on the XT.

Observe the readings of the other band G/R meters and see if they match the expected readings in Table D-2.

Table D-2
Expected Band Limiter G/R Meter Readings
With Pink Noise Excitation
(Tolerance= \pm 3dB)

<u>BAND (HZ)</u>	<u>G/R (dB)</u>
150Hz	5dB
400Hz	5dB
700Hz	5dB
1.6kHz	8dB
3.7kHz	10dB
6.2kHz	18dB

A reading outside of tolerance can indicate a problem with the control circuitry of a given band-limiter. Because of the non-periodic nature of pink noise, certain failures in the control circuitry dynamic response may also be indicated in these tests. Such failures ordinarily require return of Card #A2 to the factory for diagnosis and repair.

- d) **Verification Of Distortion-Cancellation:** If the system has passed the tests above, the XT may be considered correctly interfaced to the Main Chassis in all respects but one: The tests above do not indicate whether the output of the distortion-cancel sidechain in the XT is correctly connected to the input of the distortion-cancel filter in the Main Chassis.

The tests below verify that the distortion-cancellation system is operating correctly. If, after installation of the XT, you hear consistent "thickening" and distortion of sibilance (i.e., if "esses" sound more like "effs"), these tests should be performed. Otherwise, they may be considered optional because they are somewhat inconvenient, requiring that the covers of the XT be removed to access internal test points. In addition, a sweep generator or frequency response test set like the Tektronix 5L4N is required.

In the tests below, correct operation of the distortion-cancel sidechain is indicated by sharp selectivity in the Band 6 and Band 5 traces. Correct results from the tests on Bands 3, 2, and 1 indicate only that certain post-compressor crossover filters within the XT are operating correctly -- not that the distortion-cancel sidechain is operating correctly. However, you may wish to do the tests on Bands 3, 2, and 1 anyway for the sake of completeness.

To Perform The Test: Gain access to the XT circuit cards, following the directions in **Appendix C**.

The following test should be repeated for left and right channels in turn. In all cases, observe the output of the Main Chassis TEST JACKS with the 5L4N or scope.

All test points are located on Card #A1. Refer to the assembly drawings for that card in **Appendix J** to locate the test points. (The component reference designators for the right channel are determined by adding 10 to those from the left.)

Connect the output of the 5L4N tracking generator or the output of the sweep generator in turn to the junction of CR9/CR10 (Band 6), CR7/CR8 (Band 5), CR6/CR5 (Band 3), CR3/CR4 (Band 2), and CR1/CR2 (Band 1), verifying that the resulting traces observed at the Main Chassis TEST JACKS resemble Figs. D-2, D-3, D-4, D-5, and D-6 respectively. (These photos were taken using the 5L4N with a 20-20kHz log sweep and 10dB/division vertical sensitivity.)

After you are finished, reassemble the XT, following the instructions in **Appendix C** in reverse.

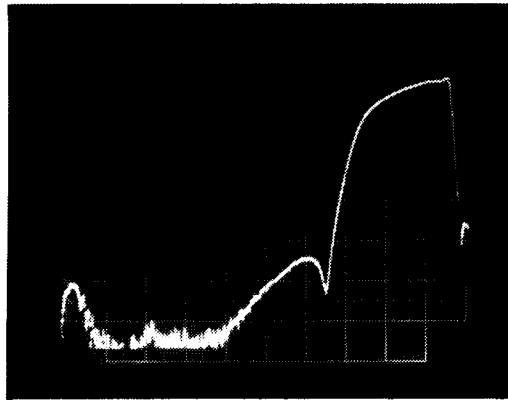

Fig. D-2: Band 6 Distortion Cancellation

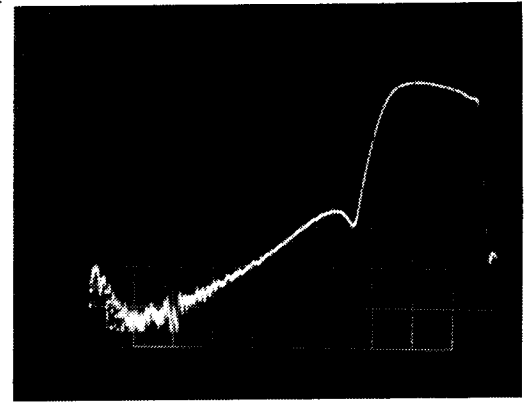

Fig. D-3: Band 5 Distortion Cancellation

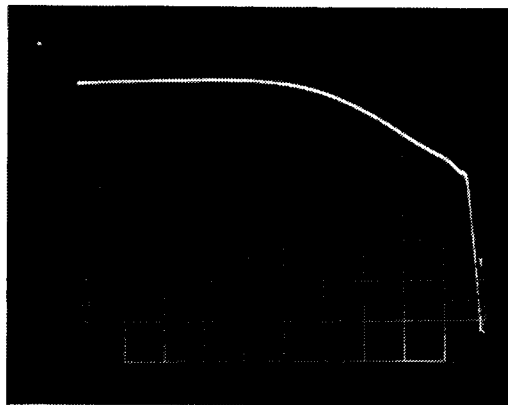

Fig. D-4: Band 3 Distortion Cancellation

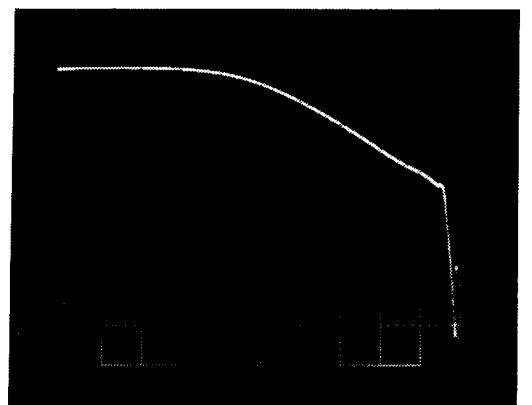

Fig. D-5: Band 2 Distortion Cancellation

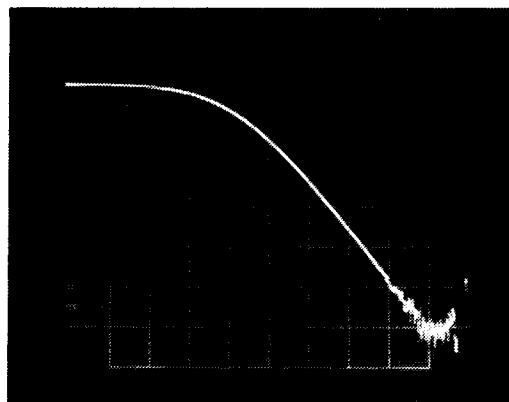

Fig. D-6: Band 1 Distortion Cancellation

APPENDIX E:

Field Alignment Procedure

1) General

The following section describes how to align and calibrate the XT in the field. It is included primarily for purposes of reference in case of component or card replacement as routine alignment is neither necessary nor desirable due to the high stability of the circuitry.

The OPTIMOD-FM system was conservatively designed with high-precision parts to minimize the number of alignment controls necessary to achieve accurate performance. However, highest performance of any individual system is assured by compensating for tolerance build-up by adjustment of alignment controls. In particular, the quiescent gains of the band VCA's on Card #A3 are aligned to compensate for cumulative tolerances in the filters and crossovers throughout the rest of the system.

While specifications will usually continue to be met after a faulty card is replaced with a factory-aligned card, best results are obtained by a touch-up alignment after such replacement. This is particularly true if Card #A3 replaced, in which case it is advisable to perform part (c) of the Card #A3 alignment procedure.

Before commencing alignment, remove both the XT and Main Chassis from their normal rack mounting location and place them on the test bench away from RF fields. Jumper the chassis and circuit grounds together on the rear-panel barrier strip. Note the normal positions of the setup controls and of the jumpers on the cards to aid reinstallation.

To minimize probability of RFI, the connecting cable between the XT and the Main Chassis is very short, making it normally impossible to operate the XT on top of the Main Chassis. By freeing the XT's connecting cable from its clamp in the XT chassis and then unthreading the cable from its hole in the chassis and passing it over the top flange of the chassis, sufficient slack becomes available to operate the XT on top of the Main Chassis, making troubleshooting much more convenient. The clamp can be freed by removing the two screws and nuts securing it to the main chassis, noting how it was installed to facilitate later reinstallation.

2) Required Test Equipment And Materials

The following test equipment (or close equivalents) is required. It is assumed that the technician is thoroughly familiar with the operation of this equipment.

- a) Digital Voltmeter, accurate to $\pm 0.1\%$
- b) Oscilloscope, DC-coupled, dual-trace, triggered-sweep, with 5MHz or better vertical bandwidth
- c) Ultra-Low Distortion Sinewave Oscillator/THD Test Set/AC VTVM (Sound Technology 1700B or 1710B)
- d) Low Frequency Spectrum Analyzer with Tracking Generator (Tektronix 5L4N plug-in with 5111 Bistable Storage Mainframe)
[Note: A sweep generator with logarithmic sweep capabilities can be substituted for the 5L4N. It is used with the oscilloscope (in X/Y mode) in a manner described in the manufacturer's instructions for the Sweep Generator.]
- e) 1 ea. 10.0K 1% 1/8w metalfilm resistor (actual wattage not critical)
- f) 1 ea. short test lead with miniature alligator clips or "E-Z-Hooks" on both ends.

Alignment Of Voltage-Controlled Amplifiers (on Card #A3)

Concept: First, the second-harmonic distortion and control-voltage feedthrough of each VCA is nulled. Then VCA gains are set.

All twelve VCA's employed in the stereo six-band limiter are designed to have the same nominal gain (41.4dB) when measured from their Card #A3 input to their output. (An exception is the L and R Band-6 VCA's, which have 46.4dB nominal gain, permitting them to take up to 30dB gain reduction.) Further loss is incorporated in certain VCA's by placing additional resistors in series with the VCA inputs. These additional resistors are located on the pre-compressor crossover card (#A1).

For purposes of field alignment, the entire OPTIMOD-FM system is swept, and the gains of the band-VCA's are adjusted to achieve flattest frequency response from each channel.

When referring to a band-VCA, we will use the reference designators for left-channel band #1 (150Hz) for convenience, with the understanding that the instructions can be extended to all other band-VCA's by exact analogy.

a) Distortion Null (all VCA's): Set the controls on the Main Chassis and the XT chassis to the positions tabulated in **(a) Standard Control Setup** of **Appendix D**. Connect the output of the oscillator in series with the 10.0K $\pm 1\%$ resistor, and connect the resistor to a short jumper lead with a miniature alligator clip or "E-Z-Hook" test lead at its other end. [If you cannot find a 1% resistor, use a 10K 5% carbon film resistor. This will slightly (but not fatally) compromise the accuracy of the gain trim adjustments in **(c)** below.]

Set the oscillator output to 1kHz at -10dBm. Connect the test clip to the (-) input of the opamp associated with the VCA. Connect this clip to the "Input Resistor" on its "Input IC" side. (The "Input Resistor" and "Input IC" for each VCA are tabulated in Table E-1.) For example, in the case of the Left Band 1 VCA, connect the clip to the IC1b side of R1.

Connect the N&D meter to the output of the VCA-under-test. The outputs of the VCA's are available at the "Output IC" as shown in Table E-1. You should observe a level of approximately +10dBm at the output of the VCA-under-test.

Table E-1
VCA Test Points

<u>VCA IDENTIFIER</u>	<u>INPUT RESISTOR</u>	<u>INPUT IC</u>	<u>OUTPUT IC & PIN #</u>
L 150Hz	R1	IC1B	IC1A, pin 1
R 150Hz	R19	IC2B	IC2A, pin 1
L 400Hz	R29	IC3B	IC3A, pin 1
R 400Hz	R47	IC4B	IC4A, pin 1
L 700Hz	R57	IC5B	IC5A, pin 1
R 700Hz	R75	IC6B	IC6A, pin 1
L 1.6kHz	R89	IC7B	IC7A, pin 1
R 1.6kHz	R107	IC8B	IC8A, pin 1
L 3.7kHz	R117	IC9B	IC9A, pin 1
R 3.7kHz	R135	IC10B	IC10A, pin 1
L 6.2kHz	R145	IC11B	IC11A, pin 1
R 6.2kHz	R163	IC12B	IC12A, pin 1

NOTES:

- 1) The "Input Resistor" is connected to pin 6 of its "Input IC". Use Pin 6 as the point to which the test clip is connected.
- 2) See Card #A3 Assembly Drawing in Appendix J for parts locations.

Measure the THD produced by each of the VCA's in turn. Adjust the VCA-under-test's DISTORTION NULL control to minimize distortion.

b) Thump Null (all VCA's):

Note: Before thump can be nulled, distortion must be nulled using procedure (a) immediately above. Readjusting any DIST NULL trimmer requires the THUMP NULL trimmer for that VCA to be renulled.

The Thump Null procedure is performed first for the Band 1, 3, and 5 VCA's, then for the Band 2, 4, and 6 VCA's. Procedure for Bands 1, 3, and 5 will be specifically described; the procedure for Bands 2, 4, and 6 is deduced by exact analogy.

Set the oscillator output level to -30dBm, and its frequency to 1kHz (where it should be already). Without disturbing the connection between the oscillator, the 10K resistor, and the test clip created in (a) above, disconnect the test clip from other circuitry and connect it to the IC26a side of R88. This modulates the bias current to the Band 1, 2, and 3 VCA's on the card at a 1kHz rate.

Now observe the output of the left and right Band 1, 2, and 3 VCA's in turn (see Table E-1), and adjust the appropriate THUMP NULL control to minimize the level of 1kHz seen.

Disconnect the test clip from R88, and connect it to the IC27b side of R175. This modulates the control current of the Band 4, 5, and 6 VCA's. Adjust the THUMP NULL control for these VCA's, proceeding by analogy to the instructions for the Band 1, 2, and 3 VCA's.

c) Six-Band Limiter VCA Gain Calibrate:

- 1) Connect the test clip (with 10K resistor) to the input test point of the 150Hz (Band 1) L VCA (see Table E-1). Set the output level of the oscillator to -10dBm and its frequency to 1kHz. (These settings should already exist.) Connect the N&D meter to the output of the VCA. Adjust R17 until +10.6dBm is observed at the VCA output.

You have now set a reference gain for Band 1. THE SETTING OF R17 MUST NOT BE CHANGED IN THE PROCEDURE BELOW!

- 2) Disconnect the test clip from any OPTIMOD-FM circuitry. Connect the sweep generator or 5L4N tracking generator to the Main Chassis L Input.
- 3) Adjust the L INPUT ATTEN and/or the sweep generator output level to achieve a maximum reading of approximately 0VU on the Main Chassis VU meter in L AGC mode. (This assures that clipping will not occur in any circuitry. The maximum will occur as the swept frequency passes through 15kHz: the highest part of the preemphasis curve.)
- 5) Connect the vertical input of the scope (or the input of the 5L4N) to the Main Chassis L TEST JACK through a 75us deemphasis network such as the one shown on p. D-3 of the **Optimod Operating Manual**. [If the test set has an input impedance of 1meg or greater, use the network as shown. If its impedance is 100K (as many test sets are), the 7.5K resistor shown in the deemphasis network should be changed to a 8.06K 1% resistor (for 75us) or to a 5.23K 1% resistor (for 50us)].

Connect the horizontal input of the scope to the sweep ramp of the sweep generator. Operate the sweep generator from 30-15,000Hz logarithmically (or operate the 5L4N in its 20-20kHz log sweep mode at 2dB/division.)

You now should be observing the swept response of the entire left channel of the OPTIMOD-FM system. Adjust the VCA GAIN controls on bands 2-6 (i.e. R45, R73, R105, R133, R161) to achieve maximally-flat response. A response better than ± 1 dB, 30-15,000Hz should be achievable.

DO NOT ADJUST R17 ON CARD #A3; IT IS THE REFERENCE GAIN AGAINST WHICH THE OTHER BANDS ARE ADJUSTED.

- 6) R **VCA Trim:** Move the sweep generator output to the right Main Chassis input, and observe the Main Chassis Right TEST JACK through the deemphasis network as described immediately above. Adjust the VCA BALANCE controls on Bands 2-6 to secure maximally-flat swept response. A response of better than ± 1 dB should be achievable.

This concludes the **Field Alignment**. Return all setup controls to their original positions before reinstalling the chassis.

APPENDIX F:

Trouble Diagnosis and Correction

[NOTE: This Appendix should be used in conjunction with Appendix F in your Optimod Operating Manual.]

INSTRUCTIONS FOR REMOVING THE XT CHASSIS FOR SERVICE AND RESTORING THE 8100A TO "STOCK" CONDITION ARE FOUND IN APPENDIX G.

When in use, the XT Chassis becomes an intrinsic part of the Main Chassis circuitry: the XT Chassis cannot be used by itself. It is therefore important to remember when troubleshooting that the XT Chassis and Main Chassis are operating together as a system. Almost all comments in **Appendix F (Trouble Diagnosis And Correction)** of the **Optimod Operating Manual** apply to diagnosis of trouble in Main Chassis/XT Chassis systems if you remember that the XT Chassis is simply an added stage between the Main Chassis HF Limiter (on Card #6) and its peak limiting system (on Cards #8 and #9).

The general comments and the comments on signal tracing on page F-1 of the **Optimod Operating Manual** are particularly applicable.

VU Meter Technique:

[This paragraph complements the identically-titled section in your **Optimod Operating Manual**.]

In a system containing the XT Chassis, the FILTER OUT positions of the Main Chassis VU meter monitor the signal after it has passed through the XT Chassis. Therefore, if the signal is normal at the COMPRESSOR OUT positions, but abnormal at the FILTER OUT position, the XT Chassis may be suspected, as well as Cards #6, #8, and #9. [The **Card Swap Technique** (below) can be used to further narrow down the possibilities.]

Card Swap Technique:

[This paragraph complements the identically-titled section in your **Optimod Operating Manual**.]

If the problem is observable on the VU meter in the FILTER OUT position but not in the COMPRESSOR OUT position, and if swapping Cards #8 and #9 or turning the links on jumper "B" on Card #6 in the Main Chassis 1/4-turn does not move the fault from one channel to the other, then the XT Chassis is almost certainly faulty.

There are no card swap techniques available for diagnosing problems within the XT Chassis. However, the bad channel can be compared to the good one by conventional signal-tracing techniques. To do this, drive the left and right system inputs with identical (mono) signals, and, moving from the input of the XT Chassis to its output, compare corresponding circuit points in the left and right channels until a difference is found. This locates the problem between the "good" and "bad" points.

Problems common to both channels within the XT Chassis are almost certainly due to faults in the limiter control circuitry (on Card #A2).

The rest of the material on **Card-Swapping Techniques** and **Failures Which Cannot Be Diagnosed By Card-Swapping** found in your **Optimod Operating Manual** apply exactly.

CATALOG OF TYPICAL SYMPTOMS

[This paragraph complements the identically-titled section in your **Optimod Operating Manual.**]

This troubleshooting guide is a catalog of some possible defects in a system containing the XT Chassis.

ALWAYS BE SURE THAT THE PROBLEM IS NOT IN THE SOURCE MATERIAL FEEDING OPTIMOD-FM OR IN OTHER PARTS OF THE SYSTEM.

--Problems with subjective sound quality, particularly problems not clearly identifiable as simple electronics failures.

- 1) Review the **CATALOG OF OPERATING OBJECTIVES AND SOLUTIONS** at the end of **Operating Instructions (Part 5)** in the **Optimod Operating Manual**, and review also the **Description And Adjustment Of The XT Chassis Operating Controls** in **Part 3** of this manual to make sure that the problem isn't simply one of setup.

--Output frequency balance doesn't sound like input.

- 1) It's not supposed to. The thresholds of the Six-Band Limiter have been adjusted to provide dynamic high frequency boost with most program material. Conversely, very bright program material will suffer loss of highs due to the unavoidable limitations of the FM preemphasis curve. In addition, the Six-Band Limiter will tend to act as an "automatic equalizer", dynamically changing the frequency balance of program material to make it more pleasing and consistent on typical small radios and in cars.
- 2) The available bass boost is limited dynamically to prevent bass from overdriving the safety clippers, thus avoiding excessive IM distortion. While OPTIMOD-FM is capable of producing punchy, well-defined bass which sounds correct and is musically balanced, highly exaggerated bass boost cannot be obtained.

--Voice too loud.

- 1) The six-band processing in the XT Chassis normally has a tendency to make voice somewhat louder than music. If a balance favoring music is desired, train the operators to peak voice lower than music on the console meters.

--Gross distortion. (See also next sections.)

- 1) Power supply voltage (supplied from Main Chassis) low. (Check AC power line voltage first.)
- 2) IC opamp failure. This must be diagnosed by signal tracing.
- 3) Failure in clipper-diode bias supplies on Card #A1 (XT Chassis) or Card #6 (Main Chassis). Low bias voltage will cause excessive clipping and will also result in abnormally low modulation. Check IC4 and associated circuitry (on card #A1) to make sure that the output from IC4 is $\pm 1.8V \pm 10\%$. Check IC613 and associated circuitry (on Card #6) to make sure that the output from IC613 is approximately $\pm 4.1VDC$.
- 4) Gross failure of IC803a, IC804a, or IC804b on Card #8 or the corresponding IC's on Card #9. This will either misbias the main signal path or add distortion to the main signal without causing the main signal to disappear.
- 5) Failure of one or more bands in the Six-Band Limiter such that distortion is injected into the signal path from the defective band. Because other bands are still operating normally, signal passage will still occur [although with strange frequency response due to the missing band(s)]. Faults can occur in the Pre-Compressor Crossovers (on Card #A1), in the VCA's (on Card #A3), and in the Post-Compressor Crossover/Multiband Clipper on Card #A1.

--Moderate to subtle distortion.

- 1) Distorted program material and/or distortion problems in studio or STL (see **Appendix K** in the **Optimod Operating Manual** for further discussion).
- 2) Check points listed in "Gross Distortion" (immediately above), for moderate deviations from normal parameters.
- 3) CLIPPING and/or DENSITY controls in the XT Chassis misadjusted.
- 4) Failure in Card #A2 (control card), such that one or more bands in the XT Chassis is producing modulation control solely by multiband clipping. This is usually indicated by the G/R meter of the affected band's reading "0" at all times.
- 5) Failure in distortion-cancelling sidechain on Cards #8 and #9. This is typically indicated by a "gritty" high end with severe sibilance splatter.

--Sibilance distortion.

- 1) Source material at OPTIMOD-FM input terminals distorted.
- 2) Failure of distortion-cancelling sidechain on Cards #8 or #9.
- 3) Failure of the control circuitry in Band 6 in the XT Chassis (6.2kHz). If Band 6 is exhibiting no gain reduction, then even a properly-operating distortion-cancelling clipper may generate some audible distortion.

--Noise is pumped up during very long pauses in material like classical music or radio drama.

- 1) Refer to **Appendix H** in this Manual for a modification which changes the nominal G/R during gating from 0dB to -10dB.

Please refer to **Appendix F** in your **Optimod Operating Manual** for a complete discussion of all of the following topics:

Factory Assistance

Diagnosis At The Component Level

Selecting And Ordering Replacement Parts

Replacement Of Components On Printed Circuit Cards

Shipping Instructions

This concludes **Appendix F (Trouble Diagnosis And Correction)**.

APPENDIX G:

Restoring the 8100A to "Stock" Condition

If it is desired to remove the XT for service or to retire it, its host 8100A can easily be restored to "stock" condition. This **Appendix** provides concise instructions for such restoration.

In the case of Cards #6, #8, and #9, there are alternate procedures depending on whether the card is a converted "8100A-type" card or if it is a newer "8100A/1-type" card. Make notes on which procedure you are following to facilitate reinstallation of the XT if desired.

Procedure

(Refer to the assembly drawing for Card #5 in this manual, and to the assembly drawings for Cards #6, 8, and 9 in the **Optimod Operating Manual**.)

- 1) Remove power from the Main Chassis.
- 2) Gain access to the Main Chassis circuit cards, following the instructions in **Appendix C** of your **Optimod Operating Manual**.
- 3) Remove Card #5. Place the links on jumpers "A", "B", and "C" in the NORMAL positions. (See the Card #5 assembly drawing in **Appendix J** of this manual.)

Examine the card to see if the change described in **Appendix H** has been made. If so, the card should be restored to "stock" condition for use without the XT chassis.

- 4) Remove Card #6. If there is a diode soldered between the center terminal of the PROOF/OPERATE switch and the PC board foil, no further work on card #6 need be done. (This will be seen only in units with serial numbers below 638000.)

If the switch is soldered to the board normally, remove the two links from jumper "B". Place them on jumper "C" in the NORMAL position. (Note that the links will be oriented 1/4-turn away from their orientation on jumper "B", in addition to being on a different set of pins.)

- 5) Remove cards #8 and #9. If there are two resistors (R804 and R805) soldered to the card by one lead only with the other lead "hanging", bend these resistors down and resolder them to their foil pads. (This will be seen only in units with serial numbers below 638000.)

If all resistors were in place, move the link on jumper "B" to the NORMAL position.

- 6) Replace all cards in their slots, and reassemble the Main Chassis. The 8100A is now ready to be put back on the air without the XT.

This concludes **Appendix G**.

APPENDIX H:

Modifying the Main Chassis to Achieve More Noise Reduction in Gated Mode

Purpose Of Modification

If program material is broadcast which contains sections of low-level audio lasting longer than 10 seconds, the system consisting of the Main Chassis plus the XT can pump up noise to disturbing levels even if the Main Chassis' GATE THRESHOLD control has been adjusted to place such material below the Main Chassis' gating threshold. (Such low-level material might be found within classical music or radio drama, for example.)

It should be emphasized that we expect program material subject to this problem to be broadcast rarely, if ever, on stations which choose XT processing, since normal 8100A processing is usually far more appropriate for such material. Information on this modification is therefore provided primarily for reference; we believe that few XT users will actually require it.

The problem occurs because the gating circuitry in the Main Chassis slows the recovery of the Main Chassis' Dual-Band Compressor instead of "freezing" the gain, permitting the gain to recover to its maximum value if the gate stays on long enough.

The XT chassis typically introduces another 10dB of gain beyond that ordinarily produced by the 8100A in its normal, non-"XT" mode. Thus, noise which was not objectionably increased by the "leaky gating" of the 8100A in its normal mode may well become objectionable when increased another 10dB by use of the XT chassis unless the modification is performed. The modification forces the gain to slowly move to 10dB G/R instead of 0dB G/R when the gate is ON, achieving 10dB less noise during long quiet sections.

Required Materials

1ea. 6.2 megohm 1/4 watt $\pm 5\%$ carbon resistor

(If you cannot obtain this part locally, please contact Orban Customer Service at the address shown on the front page of this Manual.)

Modification Procedure

[**CAUTION:** To avoid damaging the PC card, please follow the techniques described in **Replacement Of Components On Printed Circuit Boards** in **Appendix F** of your **Optimod Operating Manual**.]

- 1) Gain access to the PC cards in the Main Chassis, following the instructions on p. C-1 of your **Optimod Operating Manual**.
- 2) Remove Card #5 from its slot. Referring to the Card #5 Assembly Drawing in **Appendix J** of this Manual, locate and remove R550, a 22 megohm 1/4watt $\pm 5\%$ carbon resistor. Set it aside for use in the next step. (This resistor is located in the area behind the RELEASE TIME control.)

- 3) Referring to the Assembly Drawing, locate the holes for R552 (which should be empty). Install here the 22 megohm resistor removed in the last step. (You may have to clear the holes of solder with a vacuum-operated desoldering tool before installation.)
- 4) Locate the holes for R553, and install the 6.2 megohm 1/4watt $\pm 5\%$ carbon resistor.
- 5) Replace Card #5 in its slot, and reassemble the chassis.

This concludes the modification. To test your work, apply power to the system and observe the TOTAL MASTER G/R, COMPRESSION MASTER G/R, and TOTAL BASS G/R meters. With no signal input to the system, the GATE lamp should be lit, and all of the above G/R meters should drift slowly to "-10" (± 2).

[NOTE: In the case of the TOTAL BASS G/R METER, this will only occur if the BASS COUPLING control is set at "10", as recommended in **Part 3 (Setup)** of this Manual.]

Appendix I is intentionally omitted.

APPENDIX J: Schematics, Assembly Drawings, and Parts List

The documents in this Appendix reflect the actual construction of your unit as accurately as possible. If changes are made, they will be found in an Addendum inserted in the front of this Manual. If there is a discrepancy between these drawings and your actual unit, it more likely reflects an error in documentation than an error in the construction of your unit.

If you intend to replace parts, please consult the section in **Appendix F** of the **Optimod Operating Manual** on **Selecting And Ordering Replacement Parts**.

Schematic drawings for the major cards face the corresponding Parts Locator Drawing.

Schematic Drawings and Parts Locator Drawings for miscellaneous assemblies and the chassis interwiring follow.

TABLE OF CONTENTS

SCHEMATICS WITH PARTS LOCATOR

These cards are located in the Accessory Chassis:

Card #A1 BASS EQUALIZER, PRE-COMPRESSOR CROSSOVERS, POST-COMPRESSOR CROSSOVERS
Card #A2 6-BAND LIMITER CONTROL CIRCUITRY
Card #A3 VCA's

WIRE LIST

Card #5 COMPRESSOR CONTROL CIRCUITRY

This is an "8100A/1-type" card located in the Main Chassis

(Provided here to support 8100A's which have been upgraded with Retrofit Kit RET-27. 8100A/1 owners should refer to the **Optimod Operating Manual** for the most current schematics.)

Notes

- 1) Chassis interwiring is indicated on the Schematics for the interconnected cards.
- 2) Complete information on the 8100A/ST Studio Accessory Chassis (including the #3/4TX cards) is found in a separate Supplemental Manual shipped with that Accessory.

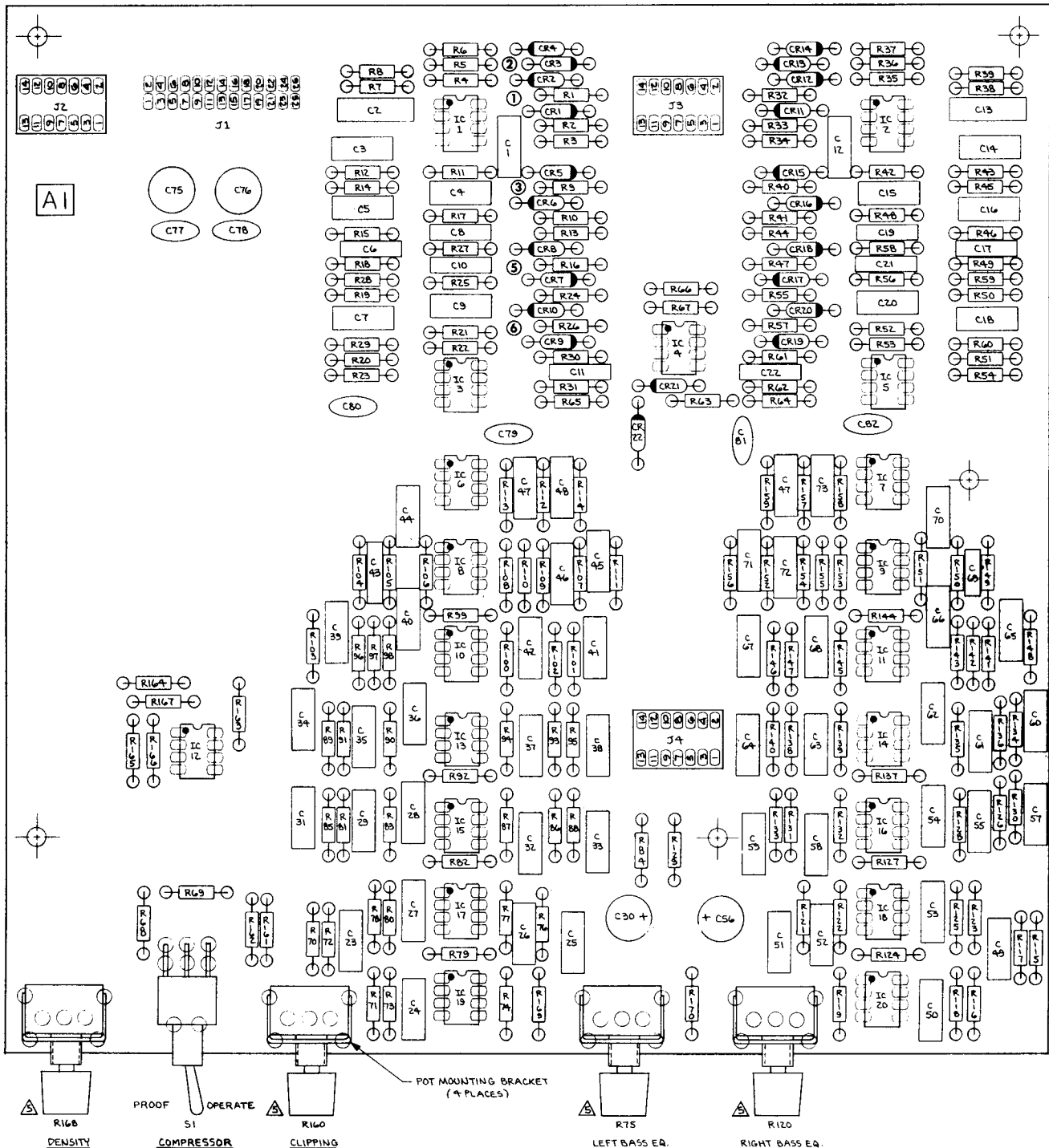

1. TICK MARKS INDICATE PIN ONE OF IC'S, MODULES;
 CATHODE OF DIODES; POSITIVE SIDE OF CAPACITORS;
 EMITTER OF TRANSISTORS.

NOTES:

orban Orban Associates Inc.

TITLE: ASSEMBLY DRAWING
 CROSSOVER BOARD #A1
 30770-000-01

FROM LEFT VCA'S

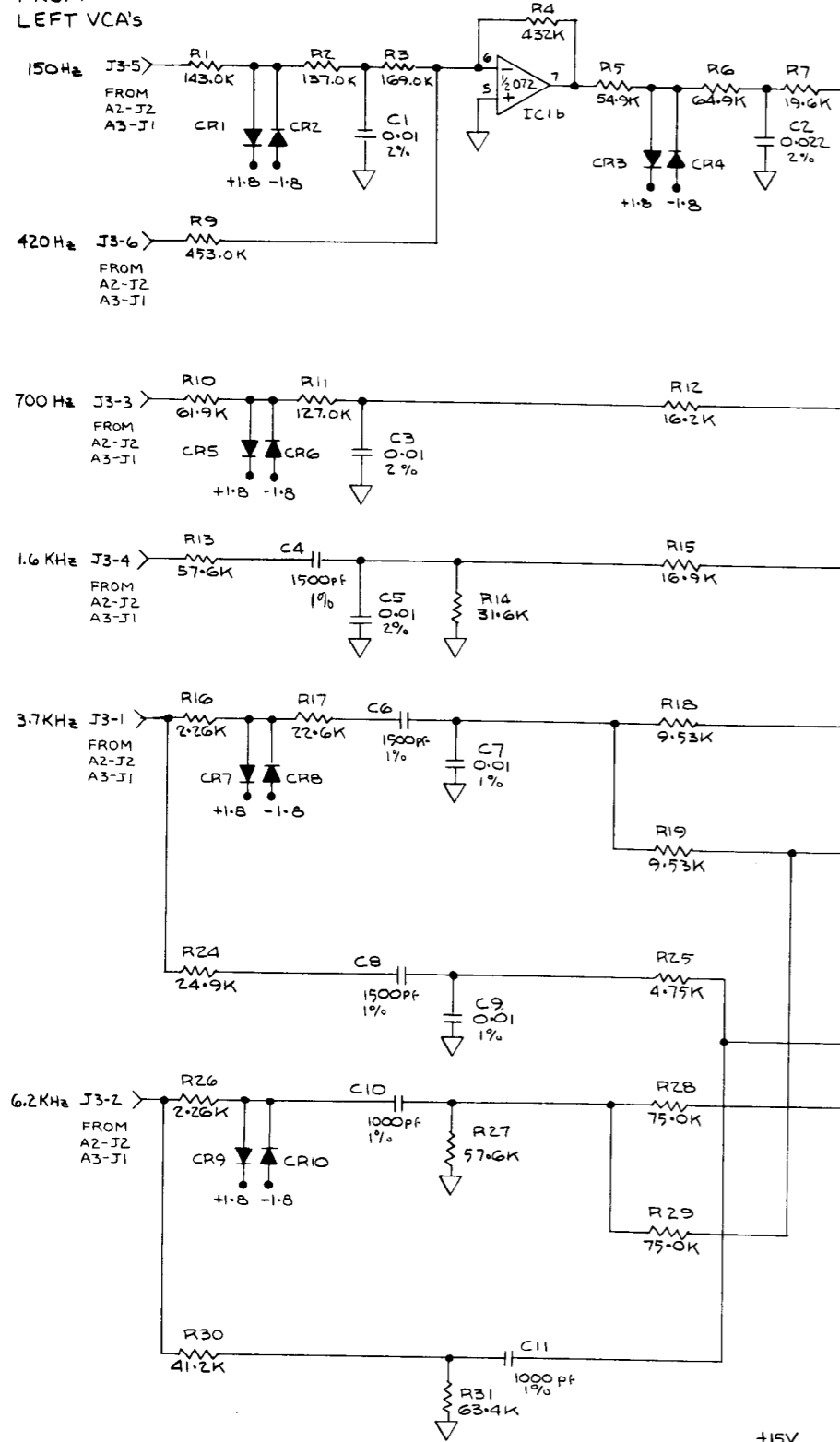

FROM RIGHT VCA'S

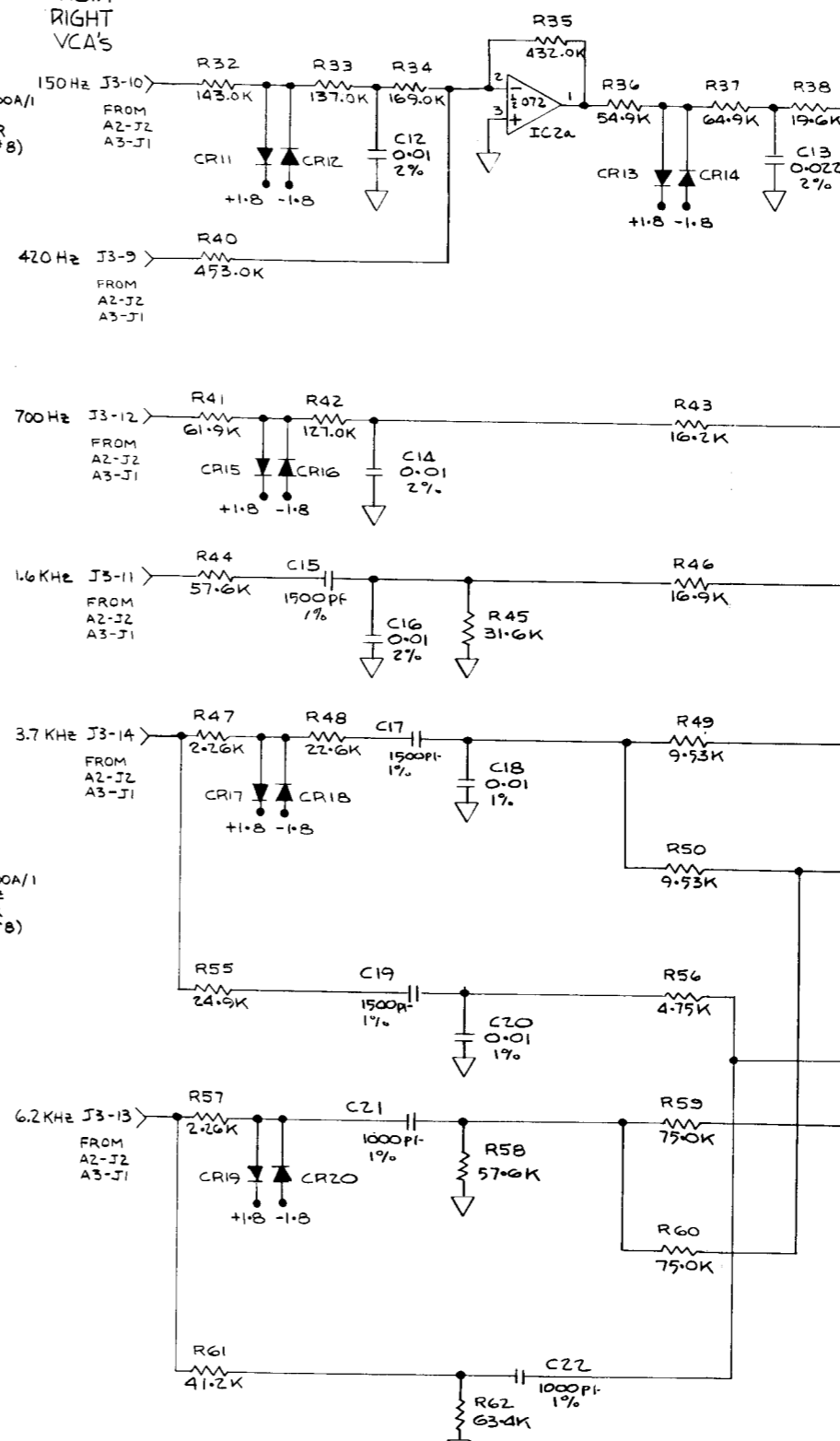

LEFT POST COMPRESSOR CROSSOVER

RIGHT POST COMPRESSOR CROSSOVER

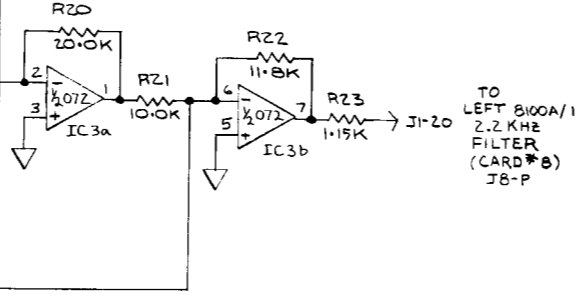

TO LEFT 8100A/1 2.2 KHZ FILTER (CARD #B) J8-P

TO RIGHT 8100A/1 15 KHZ FILTER (CARD #9) J9-M

TO RIGHT 8100A/1 2.2 KHZ FILTER (CARD #9) J9-P

- 3. ALL CAPACITANCE IN MICROFARADS
 - 2. ALL RESISTORS ARE 1/8W, MF, 1%, (RN55D)
 - 1. ALL DIODES ARE 1N4148
- NOTES: UNLESS OTHERWISE SPECIFIED

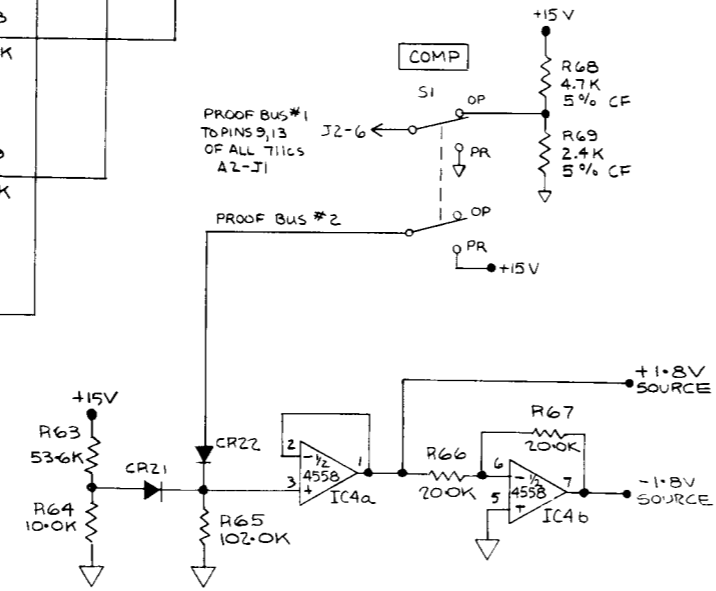

ITEM	LAST USED	NOT USED
C	C82	—
CR	CR22	—
IC	IC20	IC6a, 7b
R	R170	—
S	1	—

IC POWER + GND PINS			
DEVICE	+V	-V	GND
TLO72	8	4	—
4558	8	4	—

Orban Associates Inc.

TITLE: SCHEMATIC CROSSOVER BOARD #A1 60078-000-01, 1 OF 3

LEFT PRE COMPRESSOR
CROSSOVER

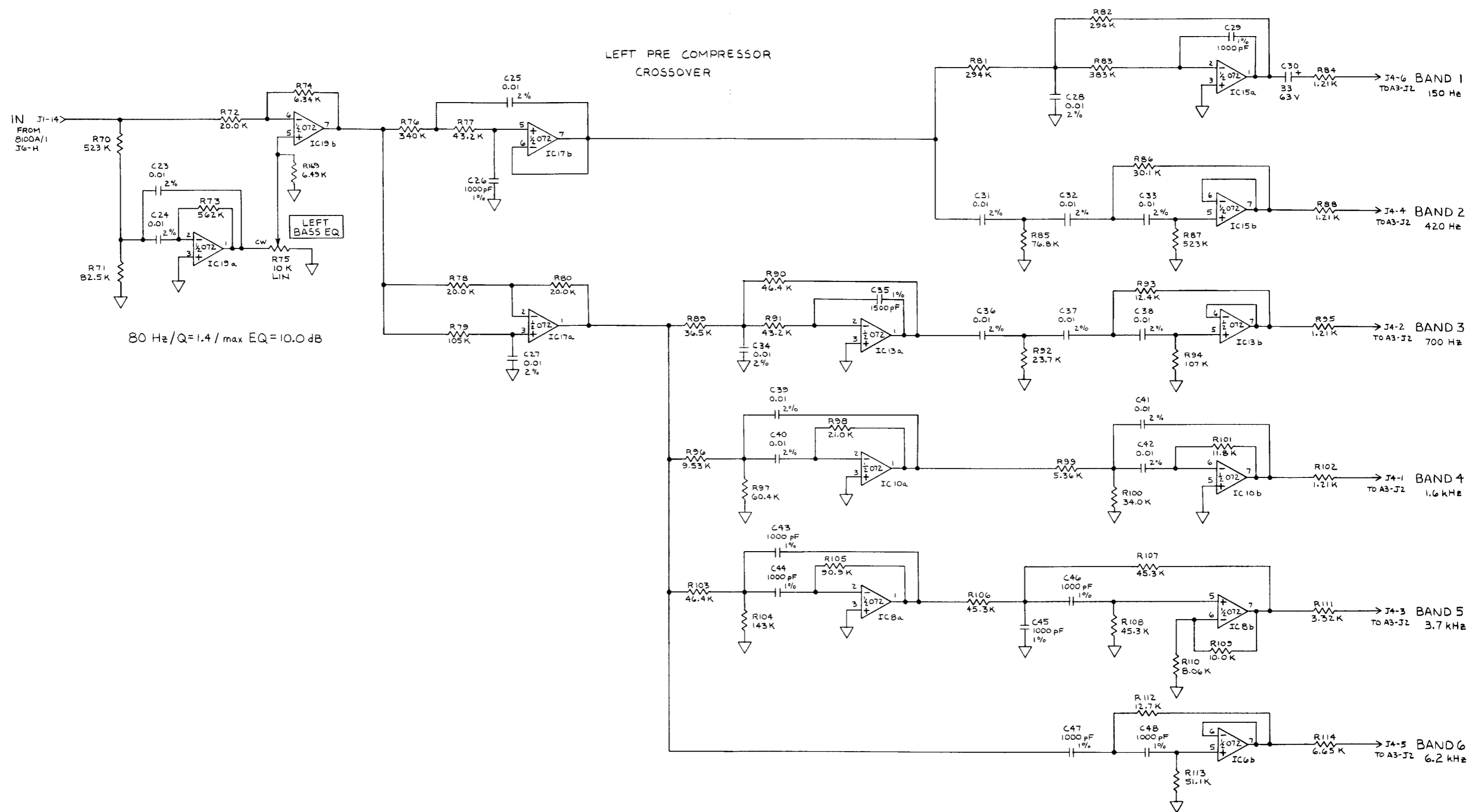

orban Orban Associates Inc.

TITLE: SCHEMATIC
CROSSOVER BOARD #A1
60078-000-01, 2 OF 3

RIGHT PRE COMPRESSOR
CROSSOVER

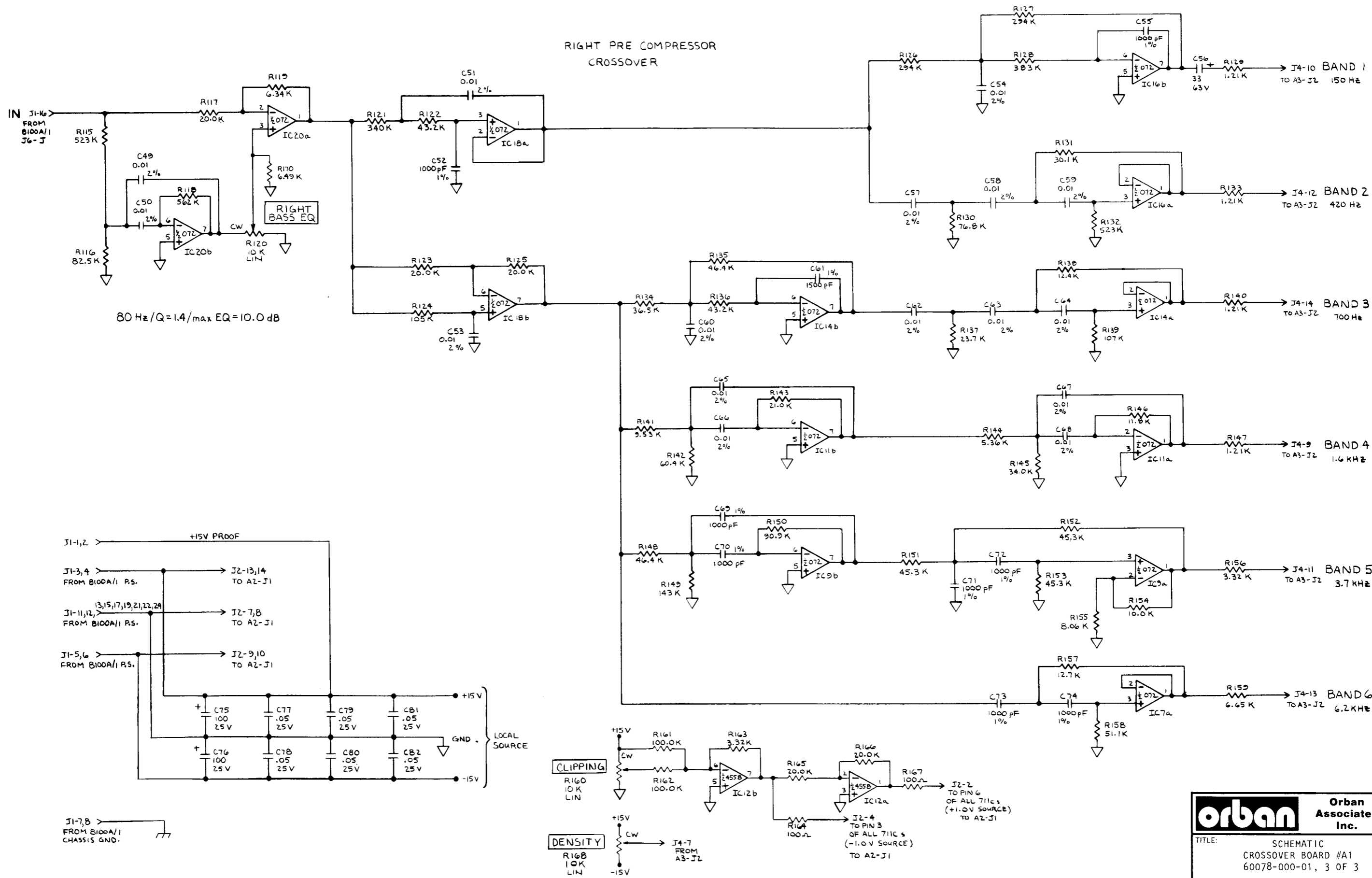

orban Orban Associates Inc.

TITLE: SCHEMATIC CROSSOVER BOARD #A1 60078-000-01, 3 OF 3

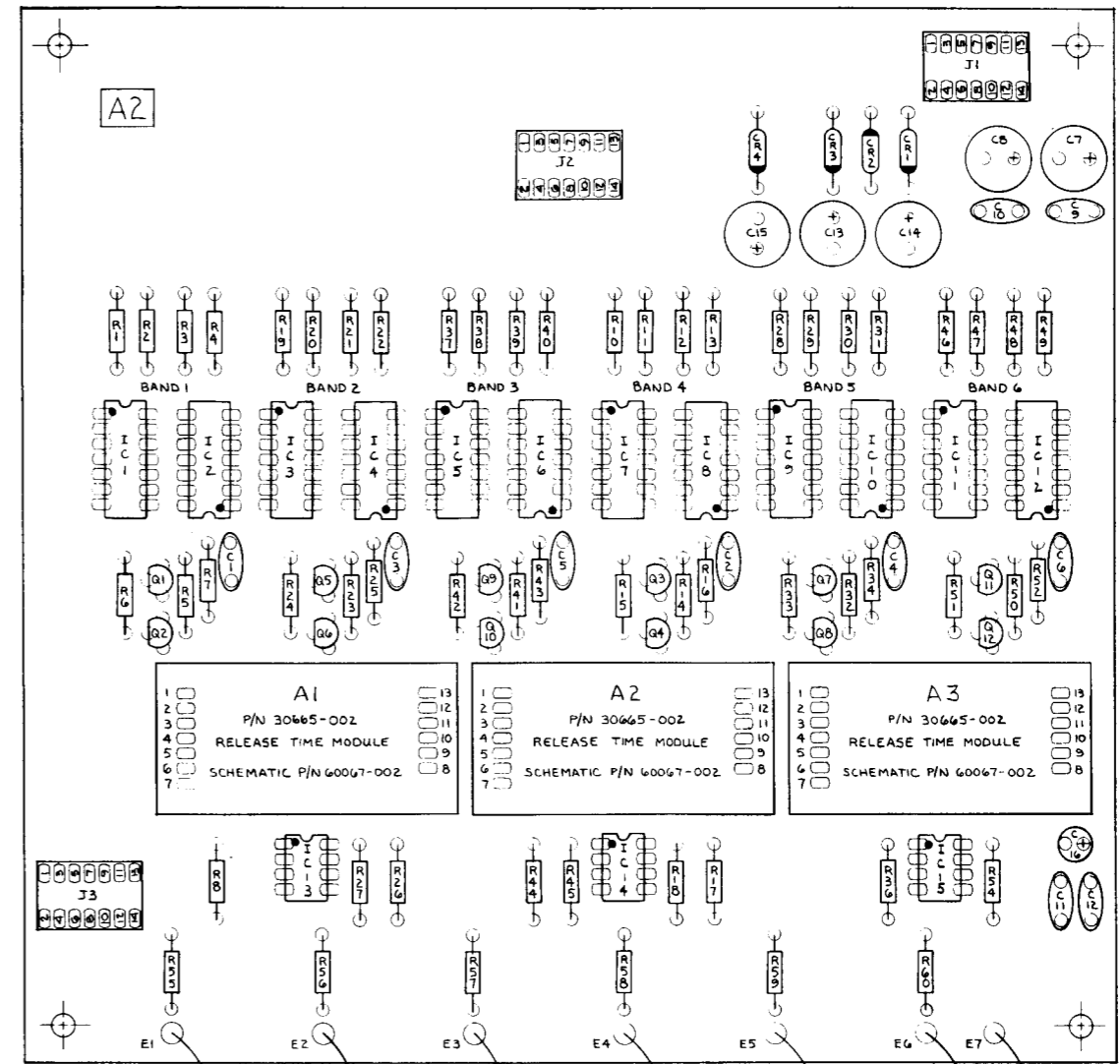

TO M1 150 Hz G/R METER
 TO M2 420 Hz G/R METER
 TO M3 700 Hz G/R METER
 TO M4 1.6 KHz G/R METER
 TO M5 3.7 KHz G/R METER
 TO M6 6.2 KHz G/R METER
 TO M1-M6 METER GND

NOTES:
 1. TICK MARKS INDICATE PIN ONE OF IC'S, MODULES;
 CATHODE OF DIODES; POSITIVE SIDE OF CAPACITORS;
 EMITTER OF TRANSISTORS.

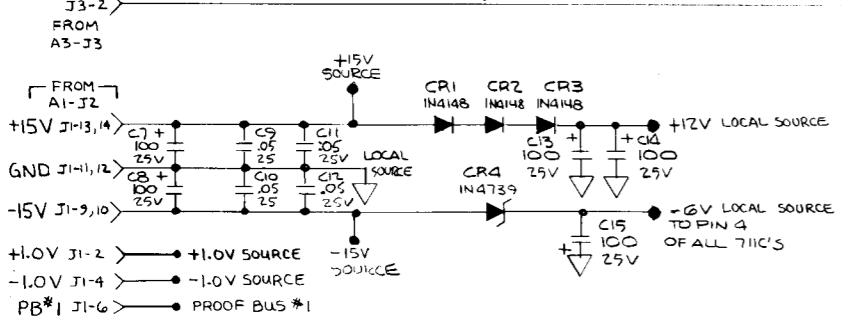
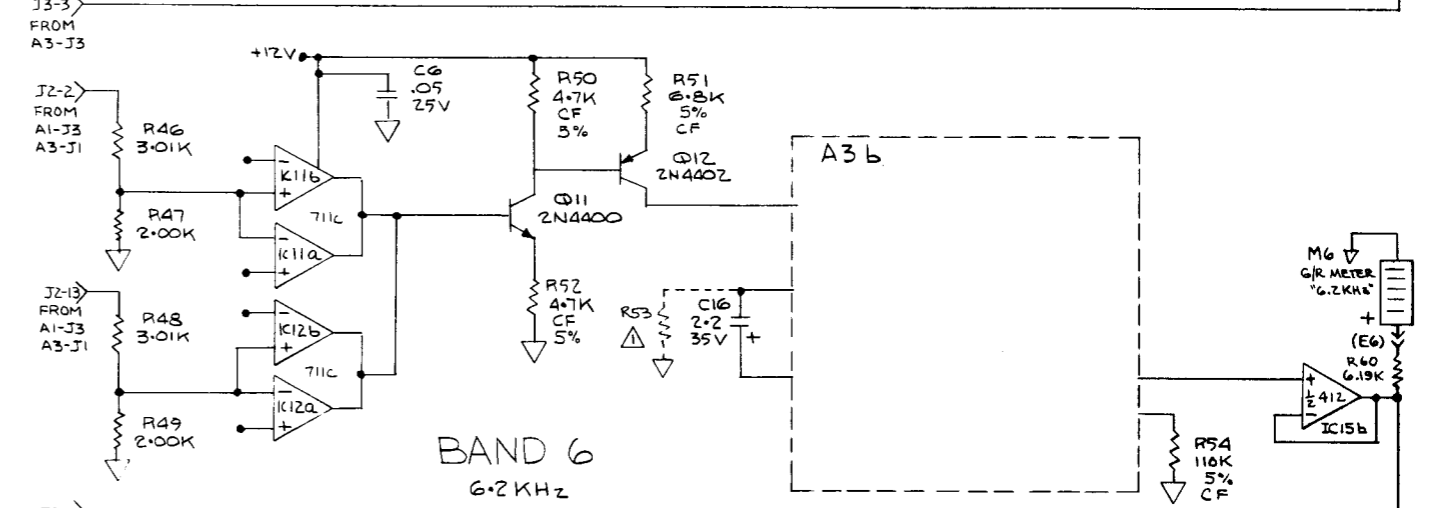
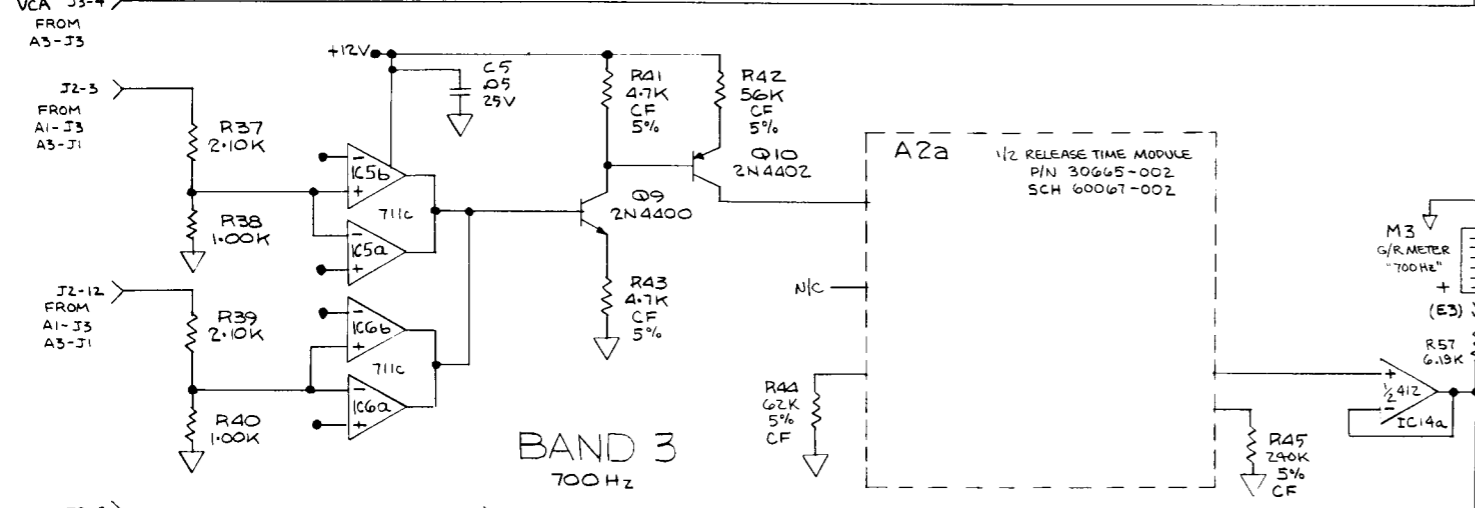
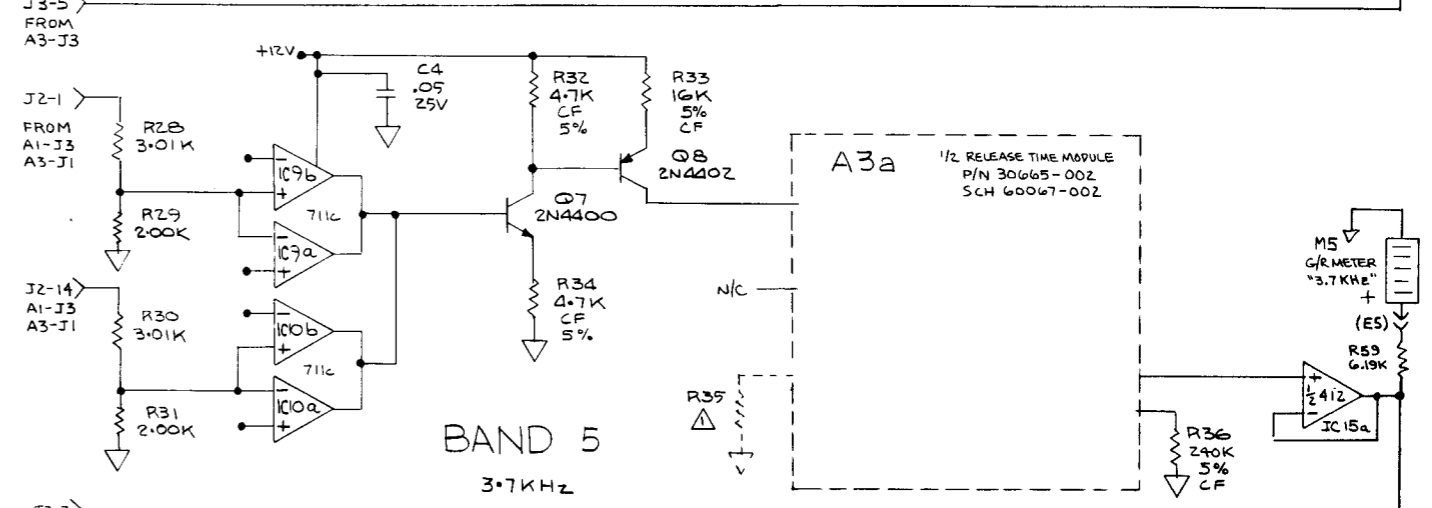
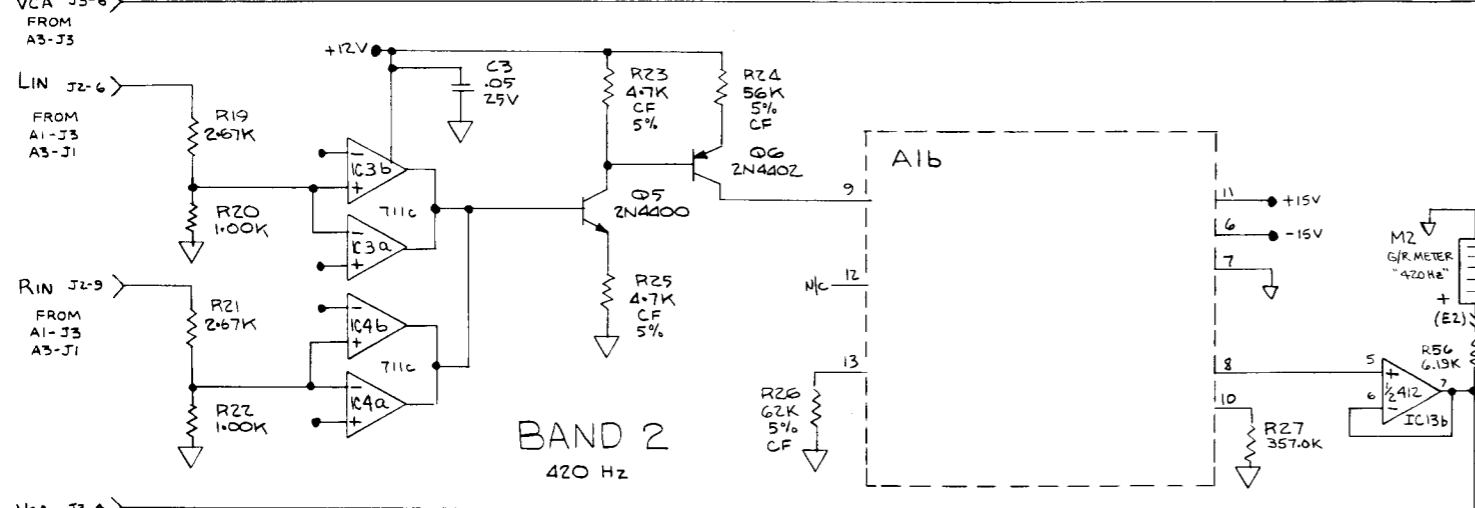
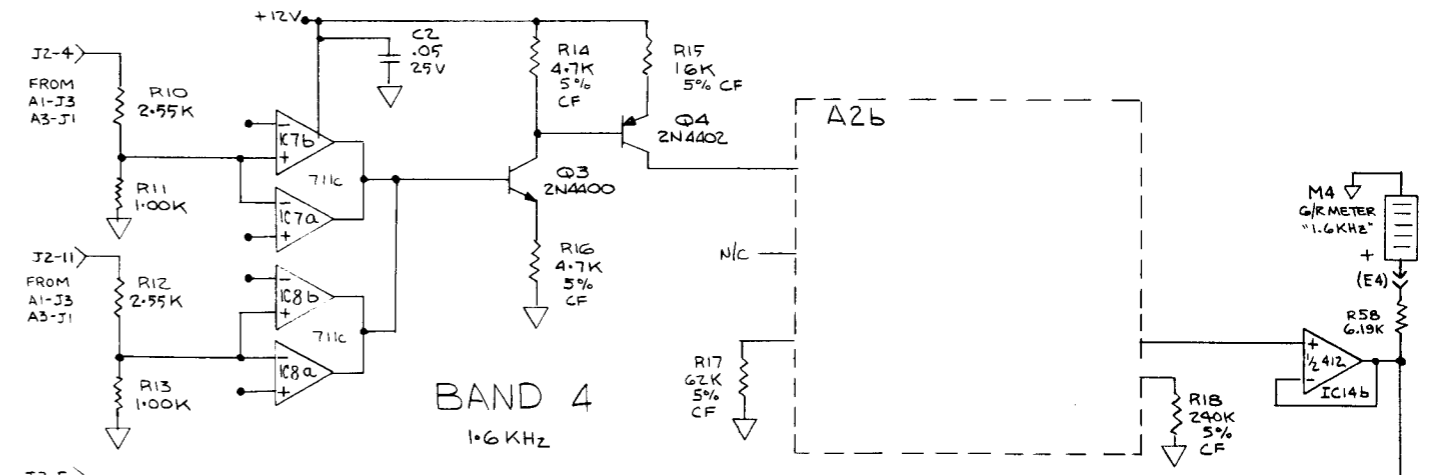
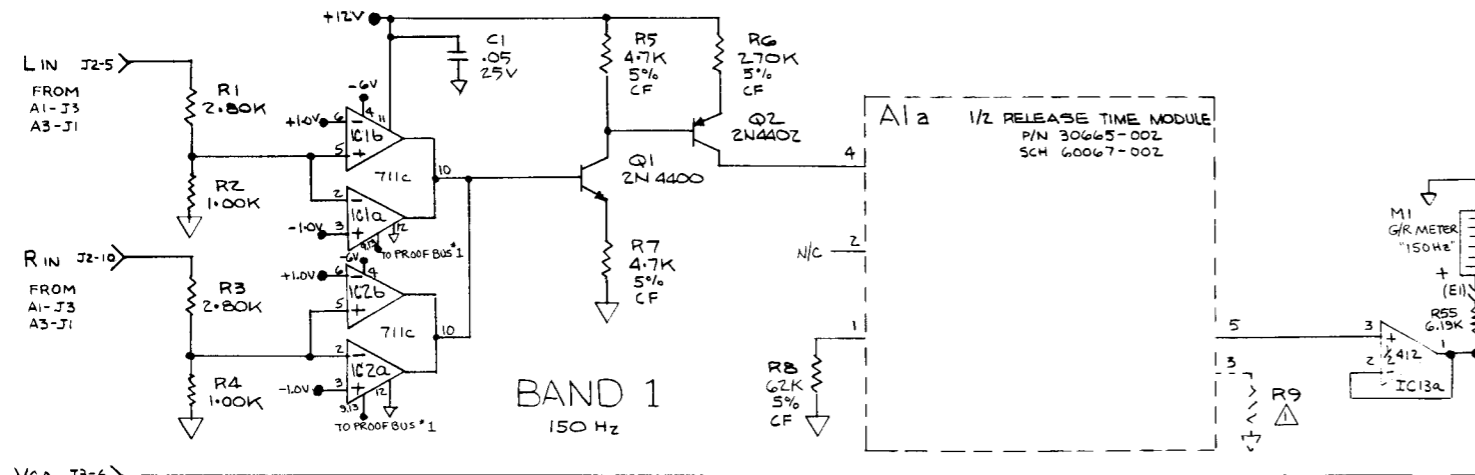

3. ALL CAPACITORS ARE IN MICROFARADS
 2. ALL RESISTORS ARE 1/8W, MF, 1%, (RN55D)

NOTES: Δ NOT LOADED

IC. PWR +GND PINS	DEVI	+V	-V	GND
41Z	8	4	-	-
711C AS SHOWN	-	-	-	-

Orban Associates Inc.

TITLE: SCHEMATIC
 LIMITER CONTROL BOARD #A2
 60076-000-01

8-C

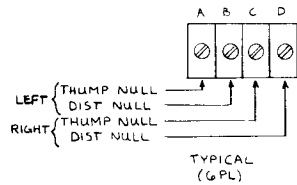
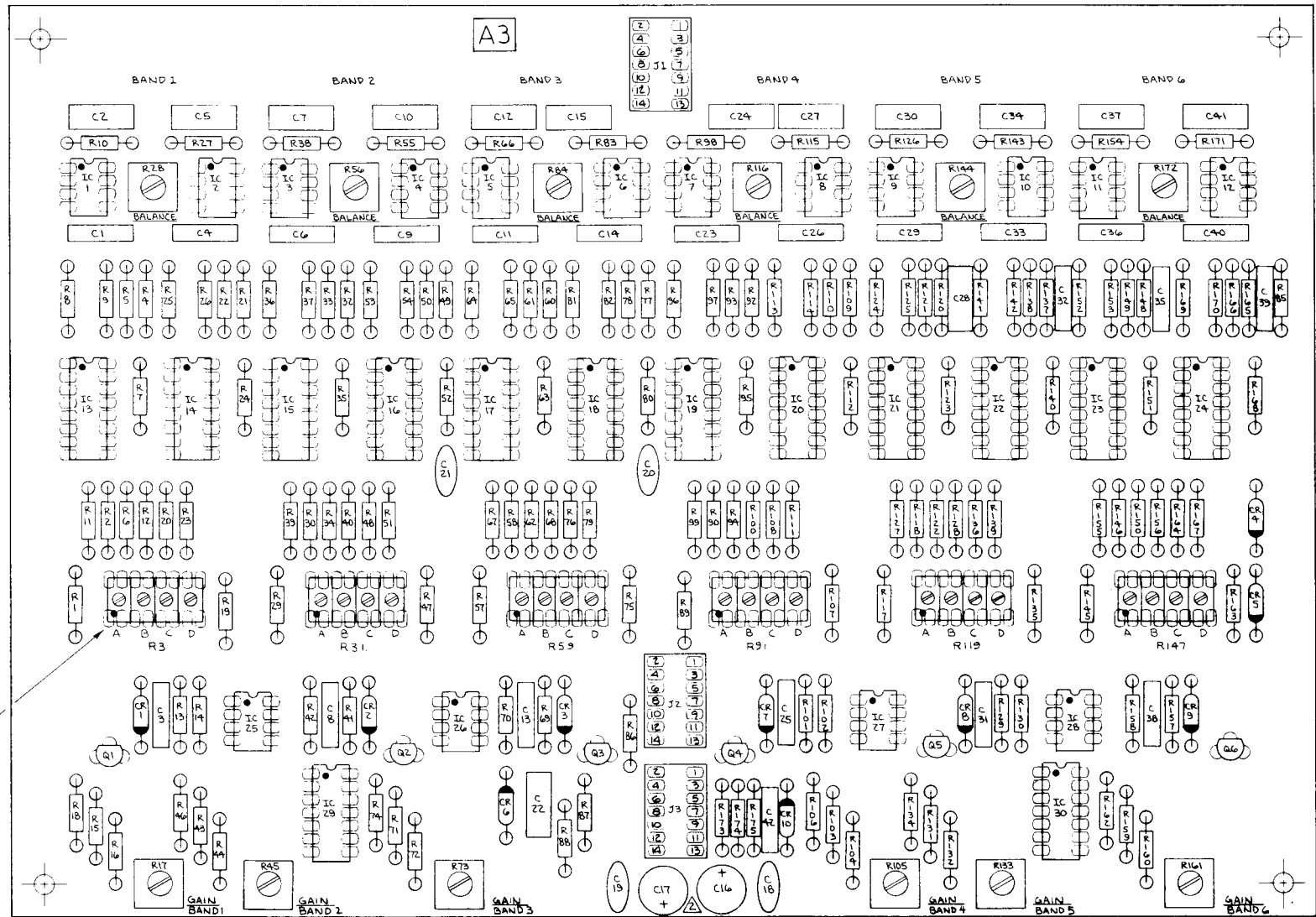

1. TICK MARKS INDICATE PIN ONE OF IC'S, MODULES;
CATHODE OF DIODES; POSITIVE SIDE OF CAPACITORS;
EMITTER OF TRANSISTORS.

NOTES:

	Orban Associates Inc.
	TITLE: ASSEMBLY DRAWING VCA BOARD #A3 30760-000-01

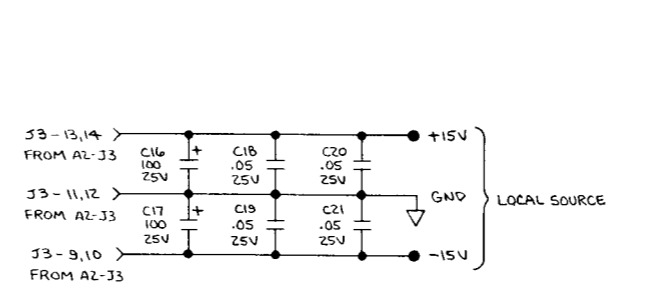
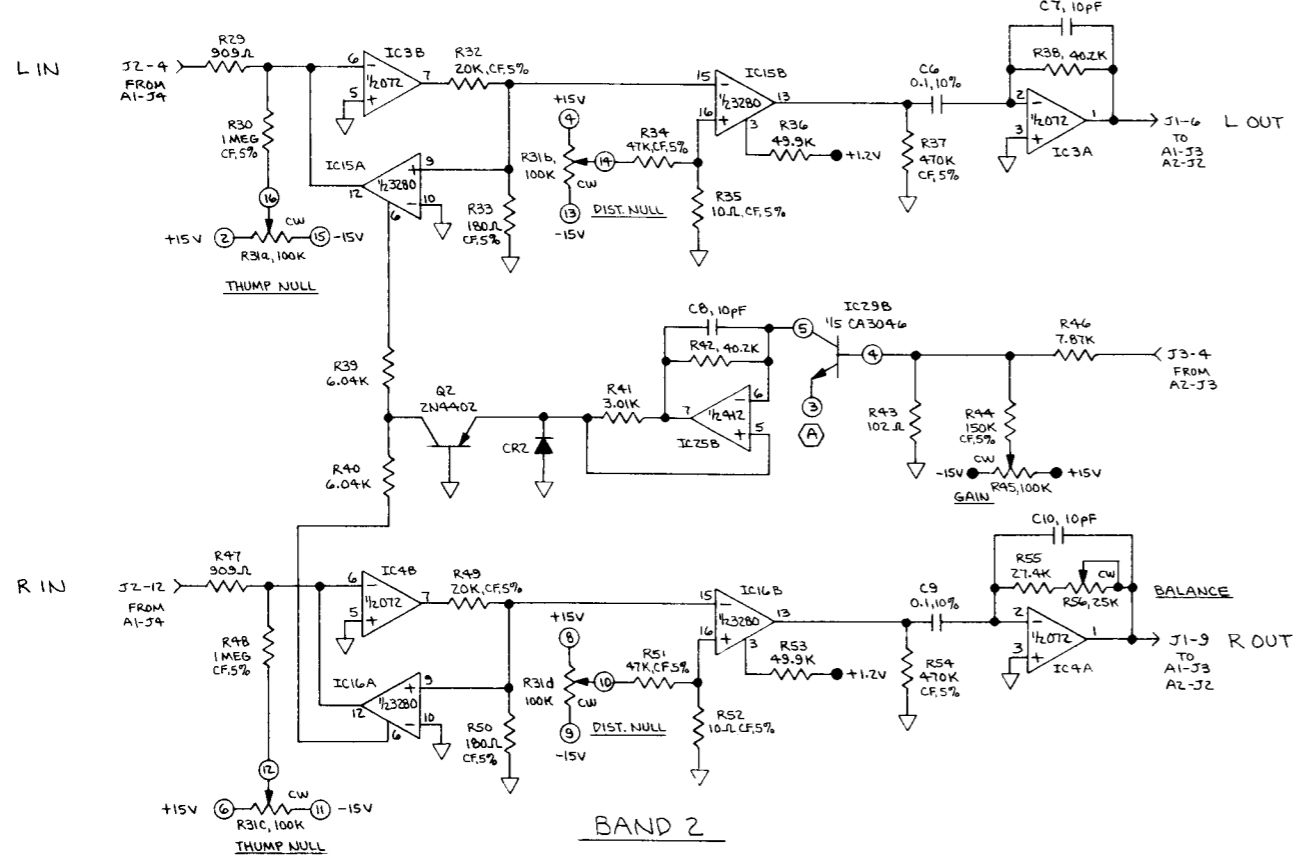
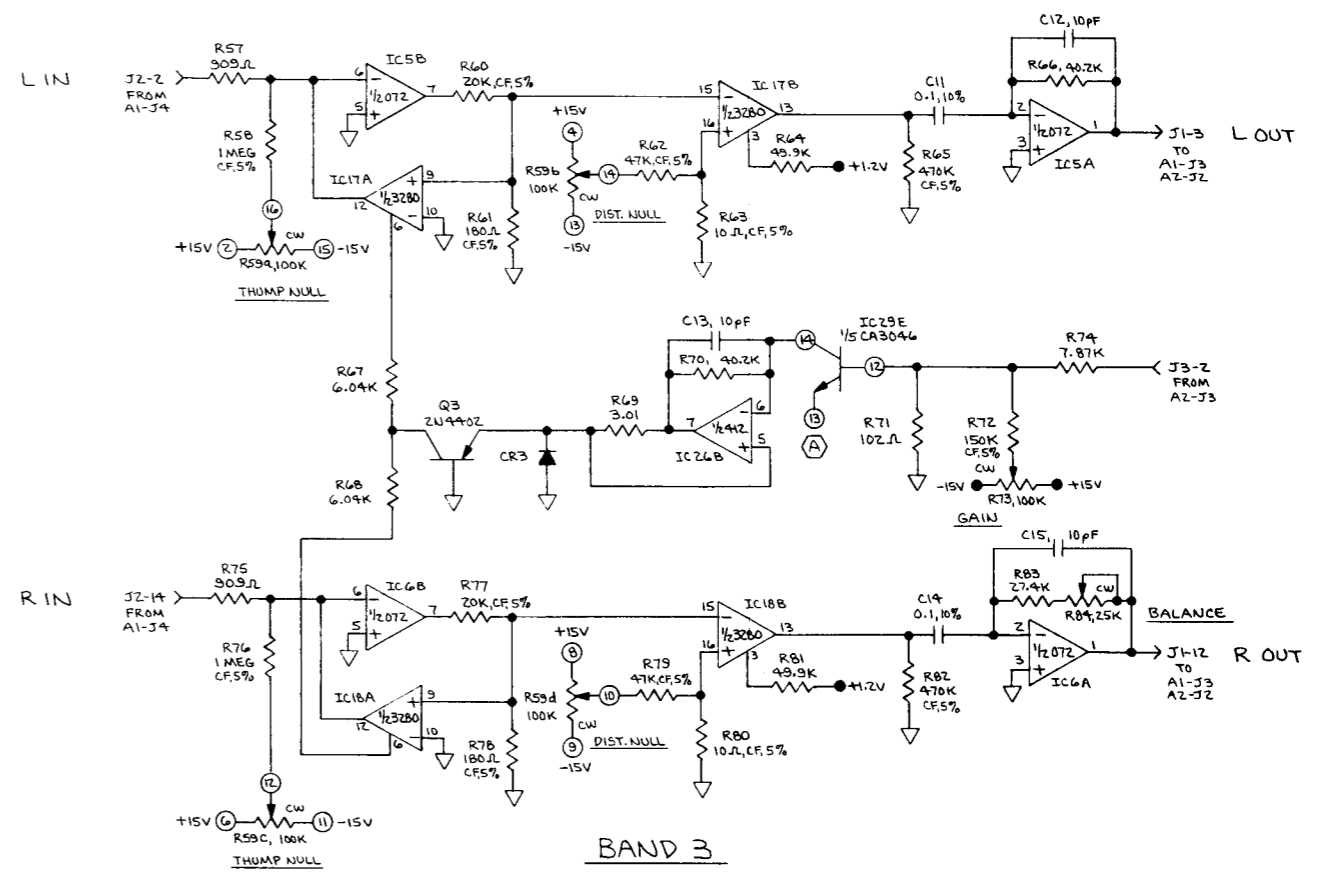
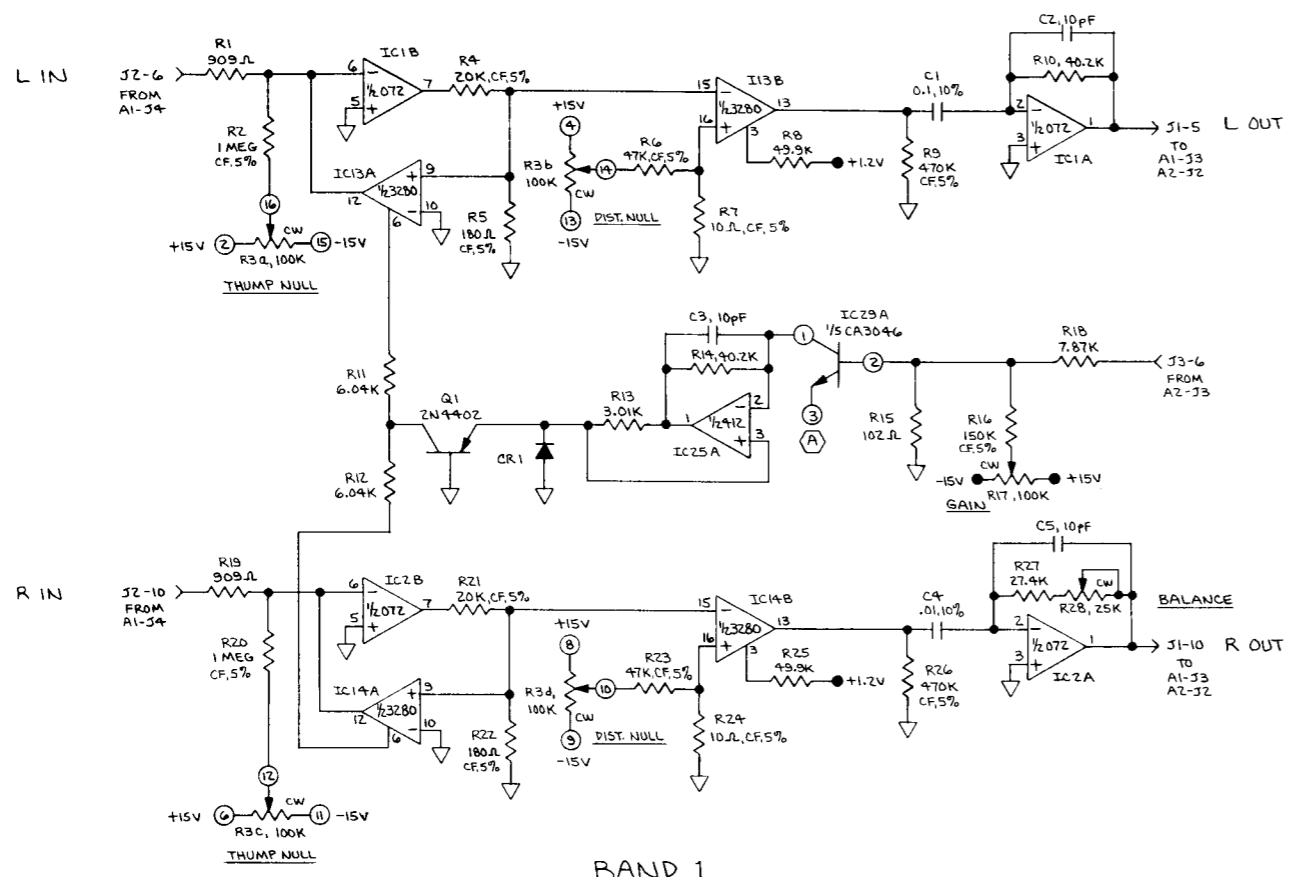

IC POWER & GROUND PINS			
DEVICE	+V	-V	GND
TL072	8	4	-
LF412	8	4	-
5532	8	4	-
3280	11,14	1,4,8	-

REFERENCE DESIGNATORS		
ITEM	LAST USED	NOT USED
R	175	-
IC	30	-
C	92	-
CR	10	-
Q	6	-

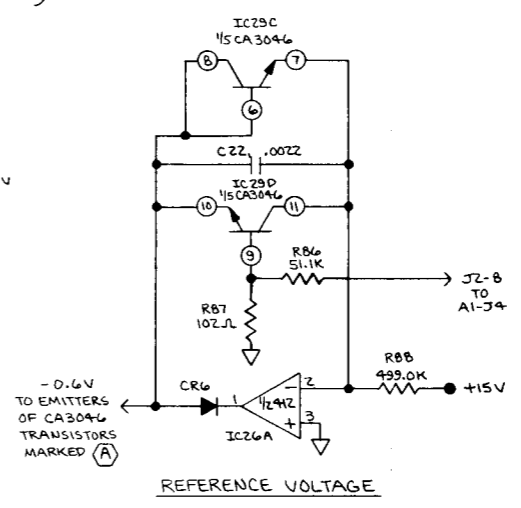
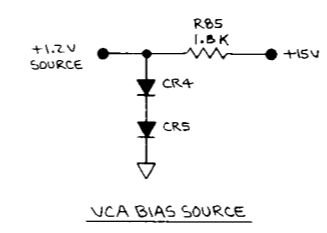

NOTES: UNLESS OTHERWISE SPECIFIED

3. ALL CAPS ARE IN MICROFARADS

2. ALL RESISTORS ARE 1/8W, MF, 1% (RN55D)

1. ALL DIODES ARE IN414B

Orban Associates Inc.

TITLE: SCHEMATIC VCA BOARD #A3 60077-000-01, 1 OF 2

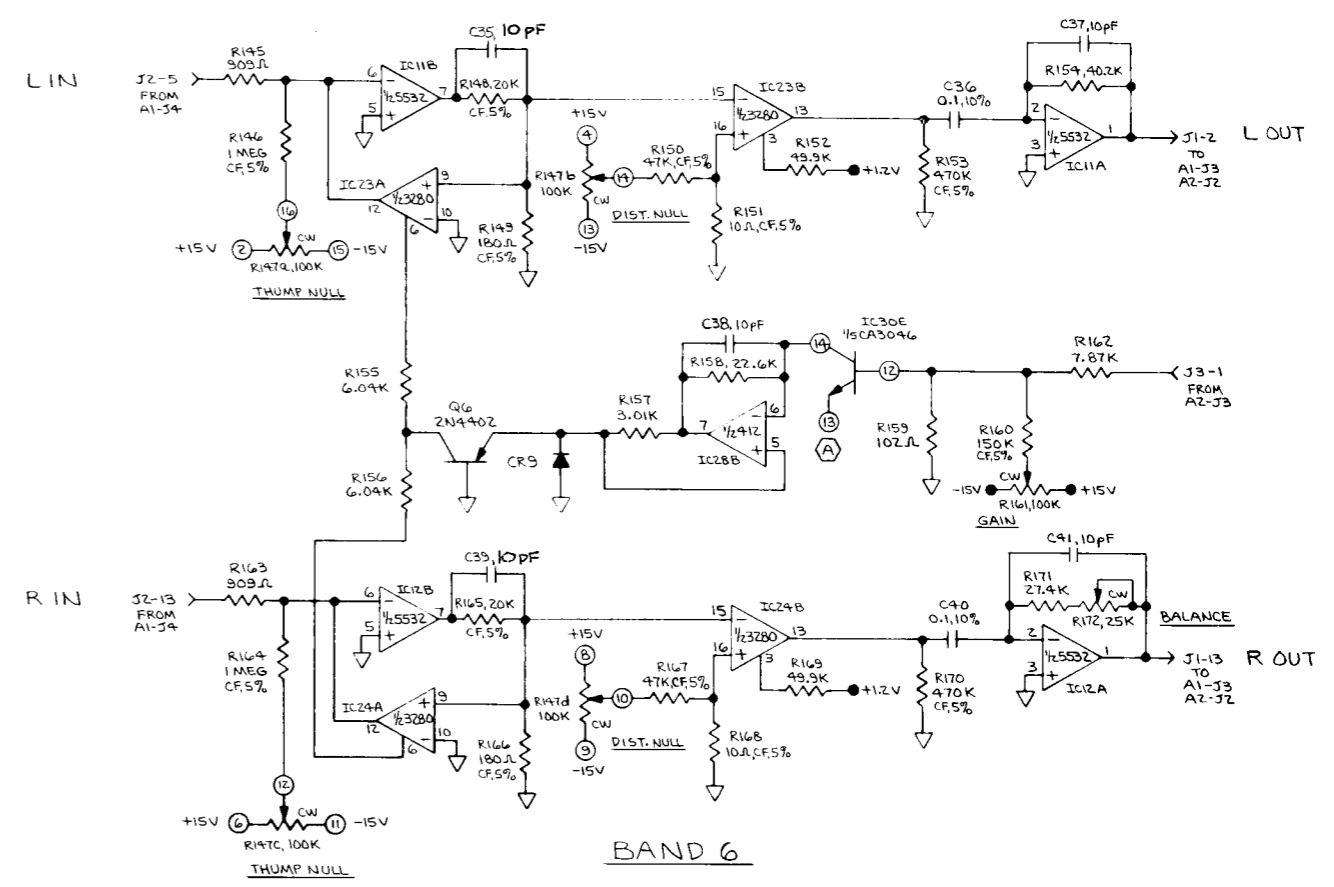
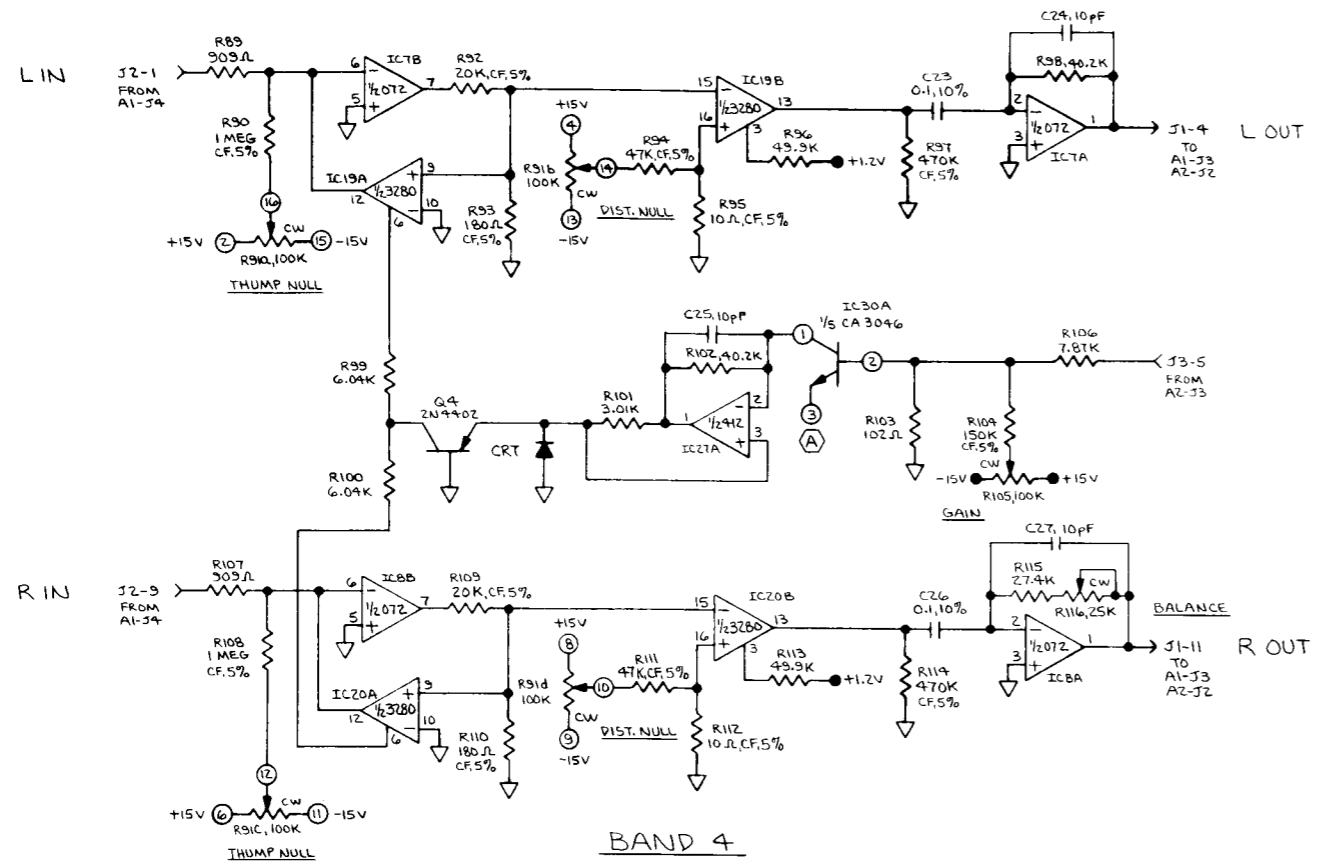

	Orban Associates Inc.
	TITLE: SCHEMATIC VCA BOARD #A3 60077-000-01, 2 OF 2

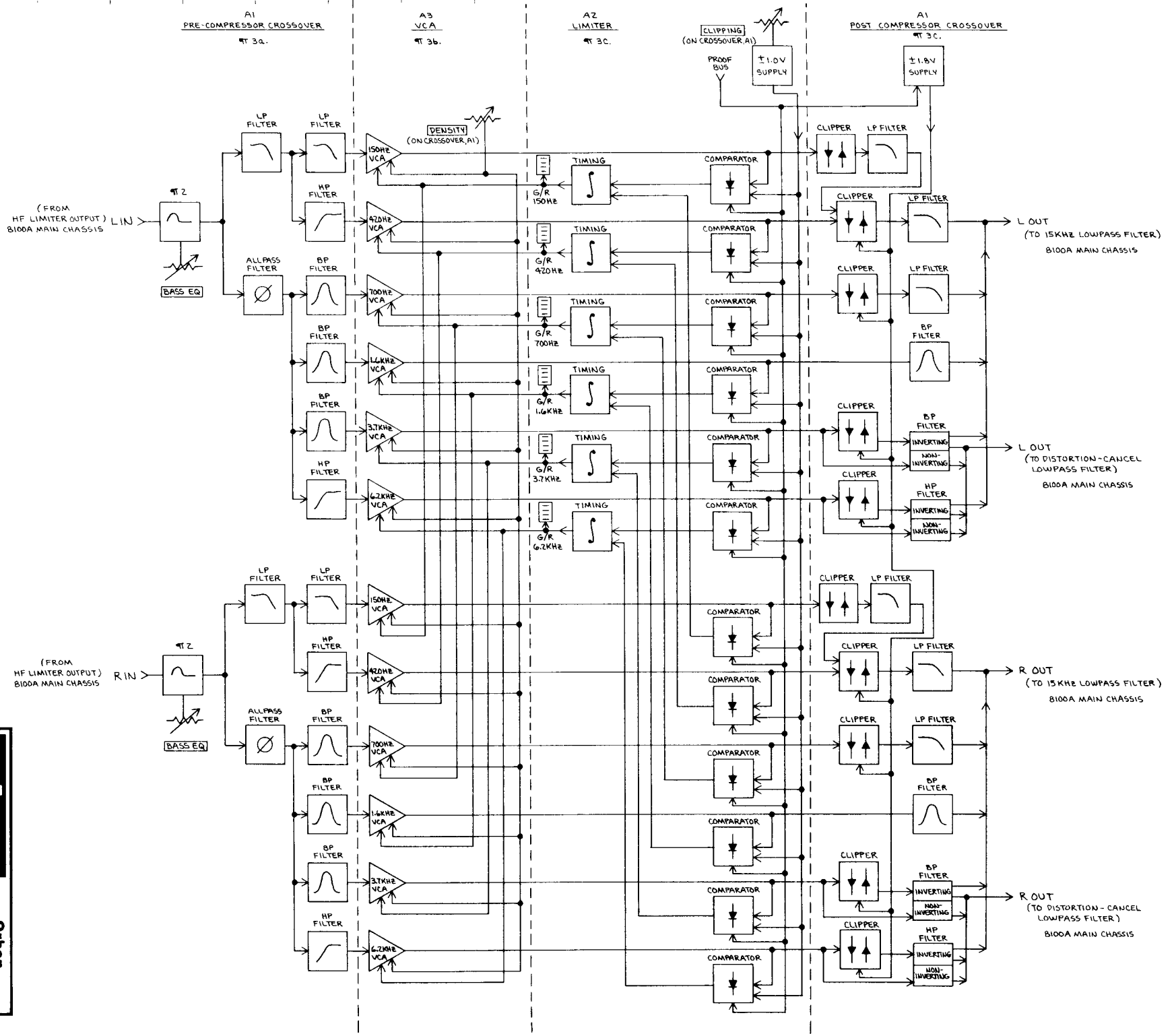

TITLE: **Urban Associates Inc.**
 SYSTEM BLOCK DIAGRAM
 60136-000-01

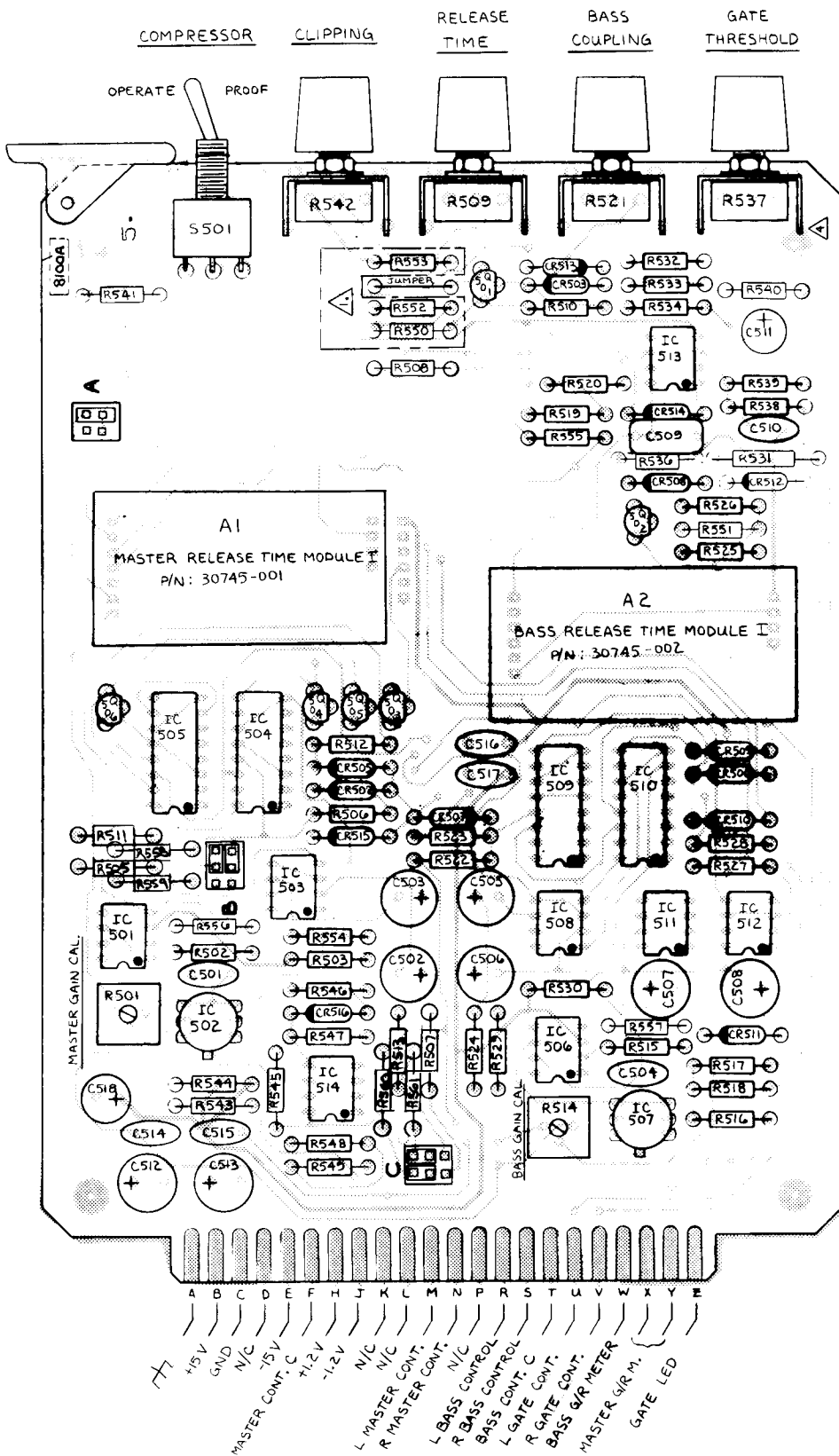

Orban Associates Inc.

orban

ASSEMBLY DRAWING
8100A/1 AUDIO CONTROL CARD #5
30715-000-03

POSITION	8100A ACCESSORY (CHASSIS MOUNT)		
	NORMAL	A	B
A			
B			
C			

6. JUMPERS SHOWN IN NORMAL (AS SHIPPED) POSITION.

3. REF SCHEMATIC: CARD #5 (60035-VER-XX)

2. THIS ASSY. SUPERSEDES ASSY NO. 30450-VER-05.

1. VERSION -001 = OPTIMOD-FM 8100A, OMIT R552, R553, INSTALL R550.
-002 = OPTIMOD-TV 8100A, OMIT R550, INSTALL R552, R553.

NOTES:

Provided for 8100A owners who have converted their units to 8100A/1 via Retrofit Kit RET-27 - See Part 2 of this Manual.

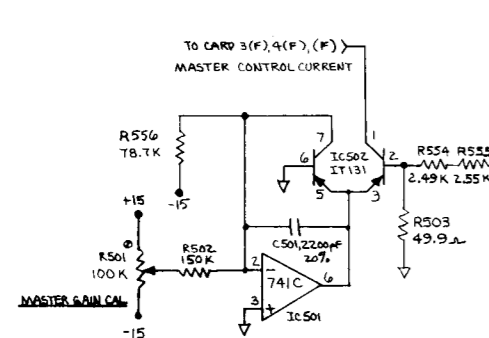

		POSITION	
		NORMAL	8100A ACCESSORY CHASSIS (A-C-D)
JUMPER	A		
	B		
	C		

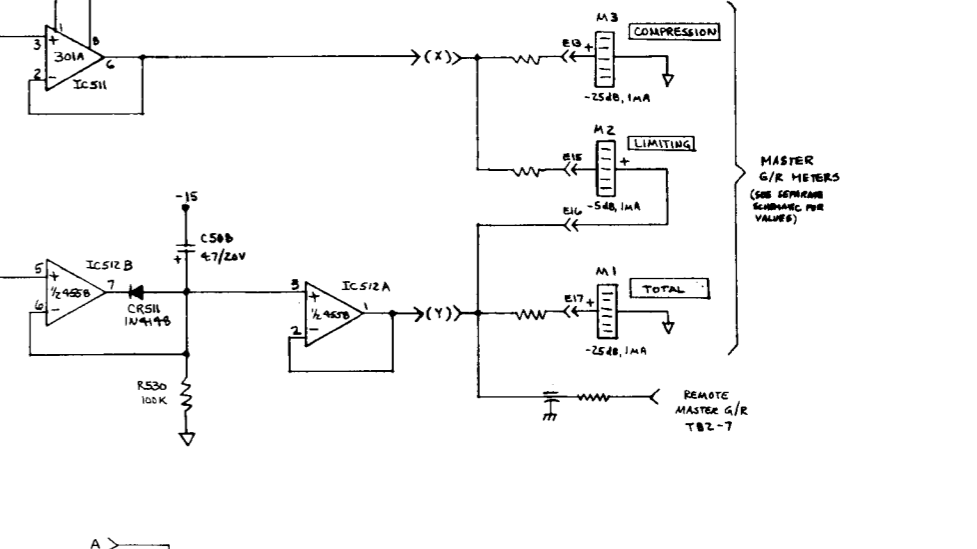
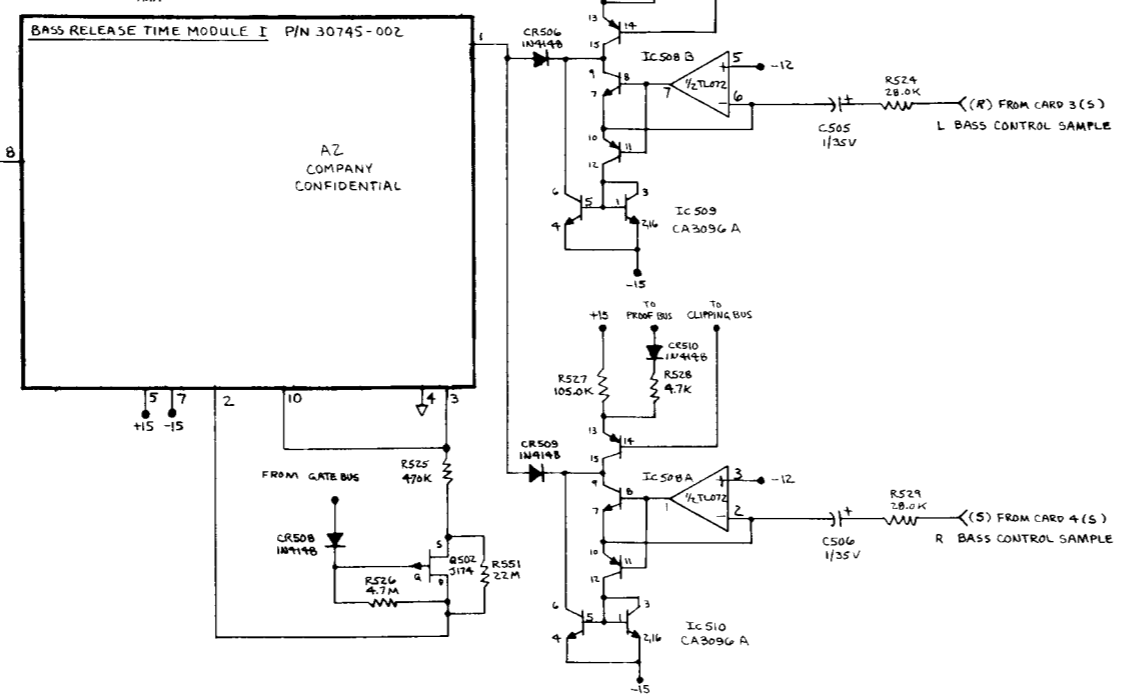
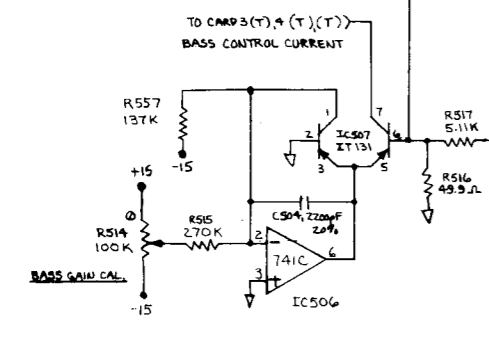
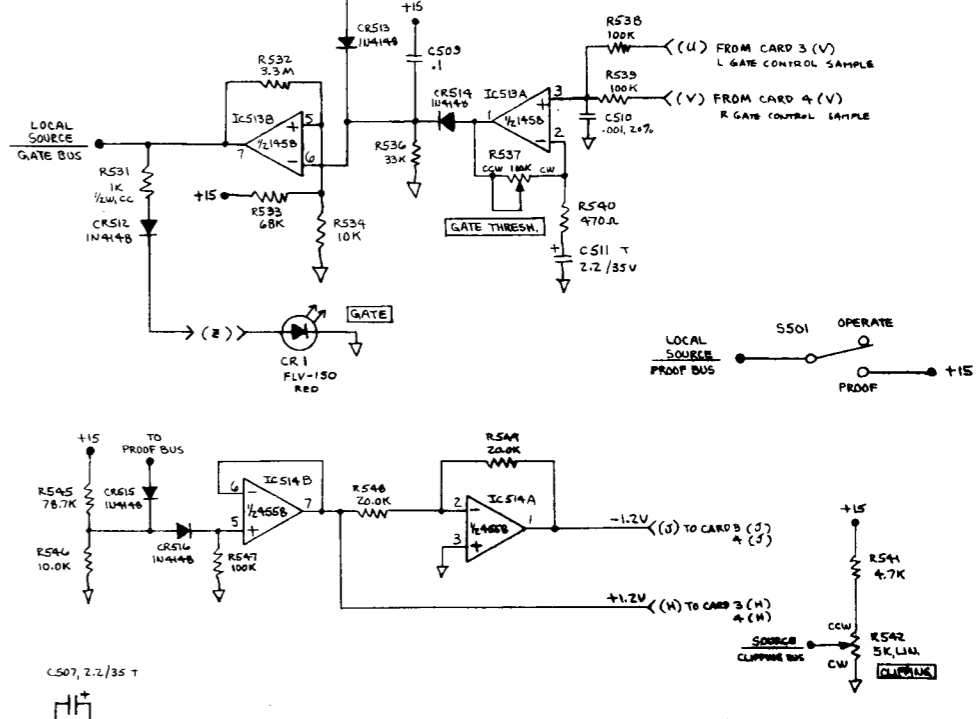
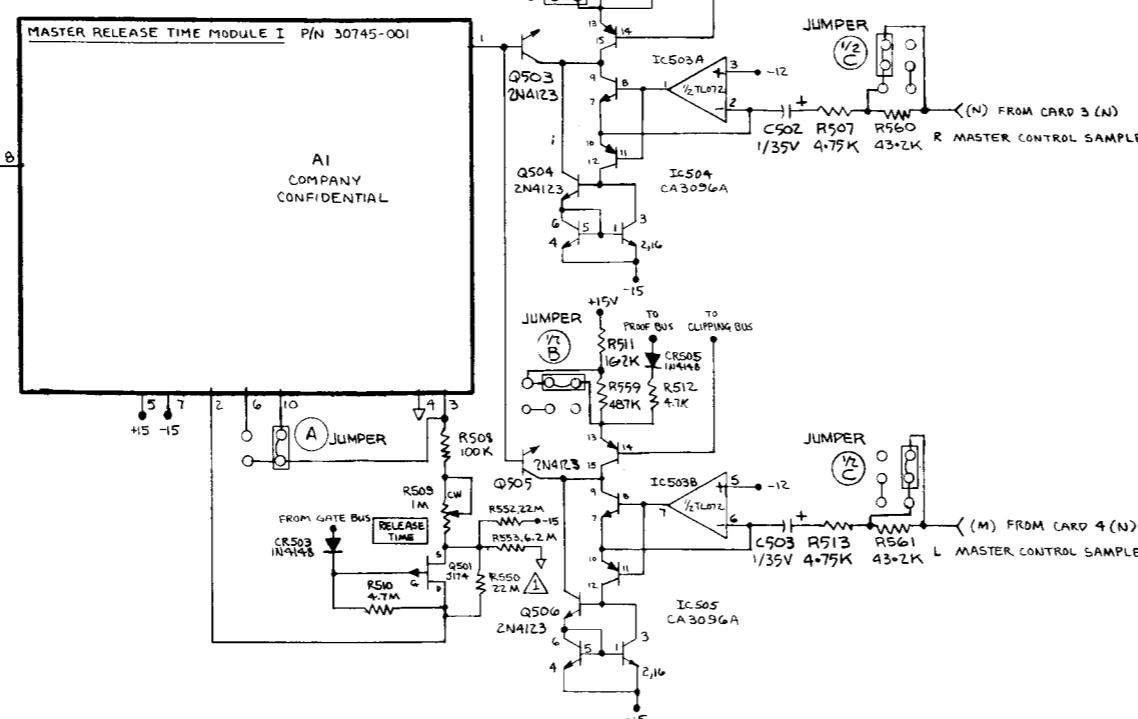

IC PINNER PINS			
SYMBOL	NO.	FUNCTION	CONNECT TO
301A	7	+	+15
TL-07Z	8	-	-15
465B	8	+	+15
741C	7	-	-15
145B	8	+	+15

REF. DES. USED			
IC	SYMBOL	LAST	SKIP
CR	516	501, 504	-
C	518	-	-
R	501	535, 504	-
Q	506	-	-
S	501	-	-

3. JUMPERS SHOWN IN NORMAL (AS SHIPPED) POSITION.
 2. REF. DOC: CARD #5 ASSY NO. 30715-VER.
 Δ VERSION -001 = OPTIMOD-FM 8100A, OMIT R552, R553
 -002 = OPTIMOD-TV 8100A, OMIT R550; ADD R552, R553

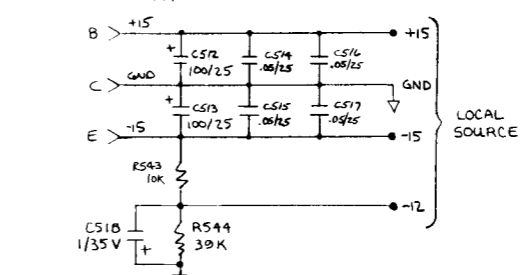

Orban Associates Inc.

TITLE: SCHEMATIC
 8100A/1 AUDIO CONTROL CARD #5
 60035-VER-07

Provided for 8100A owners who have converted their units to 8100A/1 via Retrofit Kit RET-27 - See Part 2 of this Manual.

FROM	TO	COLOR	NODE/FUNCTION	NOTES
AlJ1-1	Pl-1	FxBlu	15V Proof	To Optimod 8100A/1
2	14	Blu	15V Proof	
3	2		+15V	
4	15		+15V	
5	3		-15V	
6	16		-15V	
7	4		CH Gnd	
8	17		CH Gnd	
9	5		Dirty Gnd	
10	18		Dirty Gnd	
11	6		Clean Gnd	
12	19		Clean Gnd	
13	7		Clean Gnd	
14	20		L Limiter Out	
15	8		Clean Gnd	
16	21		R Limiter Out	
17	9		Clean Gnd	
18	22		L 15KHz Filter	
19	10		Clean Gnd	
20	23		L 2.2KHz Filter	
21	11		Clean Gnd	
22	24		Clean Gnd	
23	12		R 15KHz Filter	
24	25		Clean Gnd	
25	13		R 2.2KHz Filter	
26				
J-14				
AlJ2-1	A2J1-1	DkBlu	Not Used	
2	2	Blu	+1.0V	
3	3		Not Used	
4	4		-1.0V	
5	5		Not Used	
6	6		Proof Bus #1	
7	7		Clean Gnd	
8	8		Clean Gnd	
9	9		-15V	
10	10		-15V	
11	11		Gnd	
12	12		Gnd	
13	13		+15V	
14	14		+15V	

FROM	TO	COLOR	NODE/FUNCTION	NOTES
AlJ3-1	A2J2-1	Dk Blu	L Out Band 5	Also Goes to A3J1-1
2	2	Blu	L Out Band 6	
3	3		L Out Band 3	
4	4		L Out Band 4	
5	5		L Out Band 1	
6	6		L Out Band 2	
7	7		Not Used	
8	8		Not Used	
9	9		R Out Band 2	
10	10		R Out Band 1	
11	11		R Out Band 4	
12	12		R Out Band 3	
13	13		R Out Band 6	
14	14		R Out Band 5	
AlJ4-1	A3J2-1	Dk Blu	L In Band 4	
2	2	Blu	L In Band 3	
3	3		L In Band 5	
4	4		L In Band 2	
5	5		L In Band 6	
6	6		L In Band 1	
7	7		Density	
8	8		Density	
9	9		R In Band 4	
10	10		R In Band 1	
11	11		R In Band 5	
12	12		R In Band 2	
13	13		R In Band 6	
14	14		R In Band 3	
A2J3-1	A3J3-1	Dk Blu.	Band 6 Meter	
2	2	Blu	Band 3 Meter	
3	3		Band 5 Meter	
4	4		Band 2 Meter	
5	5		Band 4 Meter	
6	6		Band 1 Meter	
7	7		Not Used	
8	8		Not Used	
9	9		-15V	
10	10		-15V	
11	11		Ground	
12	12		Ground	
13	13		+15V	
14	14		+15V	



Orban Associates Inc.

TITLE:
CONNECTION LIST
FOR FLAT CABLES

Parts List

Parts are listed by part class (such as "Resistors"), by assembly (such as "Card #A1"), in Reference Designator order. Exceptions are certain widely-used common parts such as

- Fixed Resistors
- 3/8" Square Trimmer Resistors
- Signal Diodes

which are described generally immediately below. Such parts must be checked against the appropriate Schematic Diagram or physically examined to determine their exact value.

Obtaining Spare Parts

Because special or subtle characteristics of some components are exploited to produce an elegant design at reasonable cost, it is unwise to make substitutions for listed parts. It is also unwise to ignore notations in the Parts List indicating "Selected" or "Realignment Required" when replacing components. In such cases, the factory should be consulted to help you maintain optimum performance.

Orban ordinarily maintains an inventory of tested, exact-replacement spare parts to supply any present or normally-expected future demand quickly at a fair price.

If you order parts from the factory, please supply all of the following information:

- The Orban Part Number, if you can determine it
- The Reference Designator (like R6) for the part
- A brief description of the part
- And, from the Serial Label on the rear panel:
 - The exact Model Number (like 8100A/XT)
 - The Serial Number
 - The "M" number, if any

Orban can supply standardized Spare Parts Kits for this product during its production life. Consult your dealer or the factory to obtain a list of the prices and contents of such kits.

To ease future maintenance, parts for this unit have been chosen from the catalogs of well-known manufacturers. Their U.S. headquarter addresses are listed at the end of the Parts List. Most manufacturers have extensive distribution facilities throughout the world and can often be contacted through local offices.

Appendix K is intentionally omitted.

REF DES	DESCRIPTION	ORBAN P/N	VEN (1)	VENDOR P/N	ALTERNATE VENDORS(1)	QUAN/ SYS.	NOTES
------------	-------------	-----------	------------	------------	-------------------------	---------------	-------

MODULES

Board A2

A1	Module, Release Time	30665-002				3	Determine exact P/N from marking
A2,3	Same as A1 (Board A2)						

CAPACITORS

Board A1

C1	Polypropylene, 63V, 2.5%, .01uF	21702-310	WIM	FKP263V2.50.01		38	
C2	Polypropylene, 63V, 2.5%, .022uF	21702-322	WES	104/.022/W/63/B		2	
C3	Same as C1 (Board A1)						
C4	Mica, 500V, 1%, 1500pF	21022-215	CD	CD19FD152F03	MANY	8	
C5	Same as C1 (Board A1)						
C6	Same as C4 (Board A1)						
C7	Polypropylene, 63V, 1%, .01uF	28601-310	WIM	FKP263V2.50.01		4	
C8	Same as C4 (Board A1)						
C9	Same as C7 (Board A1)						
C10	Mica, 500V, 1%, 1000pF	21022-210	CD	CD19FD102F03	MANY	20	
C11	Same as C10 (Board A1)						
C12	Same as C1 (Board A1)						
C13	Same as C2 (Board A1)						
C14	Same as C1 (Board A1)						
C15	Same as C4 (Board A1)						
C16	Same as C1 (Board A1)						
C17	Same as C4 (Board A1)						
C18	Same as C7 (Board A1)						
C19	Same as C4 (Board A1)						
C20	Same as C7 (Board A1)						
C21,22	Same as C10 (Board A1)						
C23-25	Same as C1 (Board A1)						
C26	Same as C10 (Board A1)						
C27,28	Same as C1 (Board A1)						
C29	Same as C10 (Board A1)						
C30	Aluminum, 63V, 33uF	21209-633	SPR	502D336G063CCIC	MANY	2	
C31-34	Same as C1 (Board A1)						
C35	Same as C4 (Board A1)						
C36-42	Same as C1 (Board A1)						

FOOTNOTES:

- | | |
|---|--|
| (1) See last page for abbreviations | (4) Realignment may be required if replaced, see Circuit Description and/or Alignment Instructions |
| (2) No Alternate Vendors known at publication | |
| (3) Actual part is specially selected from part listed, consult Factory | |

SPECIFICATIONS AND SOURCES FOR REPLACEMENT PARTS

OPTIMOD-FM MODEL 8100A/XT
ACCESSORY CHASSIS

Rev 01 2/84

MODULES/CAPACITORS

REF DES	DESCRIPTION	ORBAN P/N	VEN (1)	VENDOR P/N	ALTERNATE VENDORS (1)	QUAN/ SYS.	NOTES
------------	-------------	-----------	------------	------------	--------------------------	---------------	-------

CAPACITORS, Cont'd

C43-48	Same as C10 (Board A1)						
C49-51	Same as C1 (Board A1)						
C52	Same as C10 (Board A1)						
C53,54	Same as C1 (Board A1)						
C55	Same as C10 (Board A1)						
C56	Same as C30 (Board A1)						
C57-60	Same as C1 (Board A1)						
C61	Same as C4 (Board A1)						
C62-68	Same as C1 (Board A1)						
C69-74	Same as C10 (Board A1)						
C75	Aluminum, 25V, -20% +100%, 100uF	21206-710	PAN	ECE-A1EV101S		9	
C76	Same as C75 (Board A1)						
C77	Ceramic, Disc, 25V, 20%, .05uF	21106-350	CRL	UK25-503		20	
C78-82	Same as C77 (Board A1)						

Board A2

C1-6	Same as C77 (Board A1)						
C7,8	Same as C75 (Board A1)						
C9-12	Same as C77 (Board A1)						
C13-15	Same as C75 (Board A1)						
C16	Tantalum, 35V, 10%, 2.2uF	21307-522	SPR	196D225X9035JA1		1	

Board A3

C1	Metallized Polyester, 100V, 10%, 0.1uF	21441-410	WES	60C104K100		12	
C2	Mica, \pm .5pF, 10pF	21017-010	CD	CD15CD100D03		22	
C3	Same as C2 (Board A3)						
C4	Same as C1 (Board A3)						
C5	Same as C2 (Board A3)						
C6	Same as C1 (Board A3)						
C7,8	Same as C2 (Board A3)						
C9	Same as C1 (Board A3)						
C10	Same as C2 (Board A3)						
C11	Same as C1 (Board A3)						
C12,13	Same as C2 (Board A3)						
C14	Same as C1 (Board A3)						
C15	Same as C2 (Board A3)						
C16,17	Same as C75 (Board A1)						
C18-21	Same as C77 (Board A1)						
C22	Polyester, 100V, 10%, .0022uF	21401-222	SPR	225P22291WD3		2	

FOOTNOTES:

- (1) See last page for abbreviations
(2) No Alternate Vendors known at publication
(3) Actual part is specially selected from part listed, consult Factory
(4) Realignment may be required if replaced, see Circuit Description and/or Alignment Instructions

SPECIFICATIONS AND SOURCES FOR REPLACEMENT PARTS

OPTIMOD-FM MODEL 8100A/XT
ACCESSORY CHASSIS

Rev 01 2/84

CAPACITORS

J-17

REF DES	DESCRIPTION	ORBAN P/N	VEN (1)	VENDOR P/N	ALTERNATE VENDORS (1)	QUAN/ SYS.	NOTES
------------	-------------	-----------	------------	------------	--------------------------	---------------	-------

CAPACITORS, Cont'd

C23	Same as C1 (Board A3)
C24,25	Same as C2 (Board A3)
C26	Same as C1 (Board A3)
C27	Same as C2 (Board A3)
C28	Same as C2 (Board A3)
C29	Same as C1 (Board A3)
C30,31	Same as C2 (Board A3)
C32	Same as C2 (Board A3)
C33	Same as C1 (Board A3)
C34	Same as C2 (Board A3)
C35	Same as C2 (Board A3)
C36	Same as C1 (Board A3)
C37,38	Same as C2 (Board A3)
C39	Same as C2 (Board A3)
C40	Same as C1 (Board A3)
C41	Same as C2 (Board A3)
C42	Same as C22 (Board A3)

DIODES

ALL DIODES NOT LISTED BY REFERENCE DESIGNATOR ARE:

Diode, Signal	22101-000	FSC 1N4148	Many	61
---------------	-----------	------------	------	----

NOTE: This is a silicon small-signal diode, ultra fast recovery, high conductance. It may be replaced with 1N914 or, in Europe, with BAY-61.
 BV: 75V min. @ $I_r = 5V$ I_r : 25nA max. @ $V_r = 20V$ V_f : 1.0V max. @ $I_f = 100mA$ t_{rr} : 4ns max.

Board A2

CR4	Diode, Zener, 1W, 9.1V, 10%	22003-091	MOT 1N4739	1
-----	-----------------------------	-----------	------------	---

INTEGRATED CIRCUITS

Board A1

IC1	Linear, Dual Opamp, 072	24206-402	TI TL072CJG	26
IC2,3	Same as IC1 (Board A1)			
IC4	Linear, Dual Opamp, 4558	24202-402	MOT MC4558DE	2
IC5-11	Same as IC1 (Board A1)			
IC12	Same as IC4 (Board A1)			
IC13-20	Same as IC1 (Board A1)			

FOOTNOTES:

- | | |
|---|--|
| (1) See last page for abbreviations | (4) Realignment may be required if replaced, see Circuit Description and/or Alignment Instructions |
| (2) No Alternate Vendors known at publication | |
| (3) Actual part is specially selected from part listed, consult Factory | |

SPECIFICATIONS AND SOURCES FOR
REPLACEMENT PARTS

OPTIMOD-FM MODEL 8100A/XT
ACCESSORY CHASSIS

Rev 01 2/84
CAPACITORS/DIODES/IC's

81-18

REF DES	DESCRIPTION	ORBAN P/N	VEN (1)	VENDOR P/N	ALTERNATE VENDORS (1)	QUAN/ SYS.	NOTES
------------	-------------	-----------	------------	------------	--------------------------	---------------	-------

INTEGRATED CIRCUITS, Cont'd

Board A2

IC1	Comparator, 711	24701-502	TI	UA711CJ		12	
IC2-12	Same as IC1 (Board A2)						
IC13	Linear, Dual Opamp, LF412	24209-202	NAT	LF412CN		7	
IC14,15	Same as IC13 (Board A2)						

Board A3

IC1-8	Same as IC1 (Board A1)						
IC9	Dual Opamp, 5532	24207-402	SIG	NE5532		4	
IC10-12	Same as IC9 (Board A3)						
IC13	Dual Opamp, 3280	24208-303	RCA	CA3280AG		12	
IC14-24	Same as IC13 (Board A3)						
IC25-28	Same as IC13 (Board A2)						
IC29	Multiple Discrete, 3046	24402-302	RCA	CA3046		2	
IC30	Same as IC29 (Board A3)						

TRANSISTORS

Board A2

Q1	Signal, NPN, 2N4400	23202-101	FSC	2N4400		6	
Q2	Signal, PNP, 2N4402	23002-101	FSC	2N4402		12	
Q3	Same as Q1 (Board A2)						
Q4	Same as Q2 (Board A2)						
Q5	Same as Q1 (Board A2)						
Q6	Same as Q2 (Board A2)						
Q7	Same as Q1 (Board A2)						
Q8	Same as Q2 (Board A2)						
Q9	Same as Q1 (Board A2)						
Q10	Same as Q2 (Board A2)						
Q11	Same as Q1 (Board A2)						
Q12	Same as Q2 (Board A2)						

Board A3

Q1-6	Same as Q2 (Board A2)						
------	-----------------------	--	--	--	--	--	--

FOOTNOTES:

- | | |
|---|--|
| (1) See last page for abbreviations | (4) Realignment may be required if replaced, |
| (2) No Alternate Vendors known at publication | see Circuit Description and/or Alignment |
| (3) Actual part is specially selected from part listed, consult Factory | Instructions |

SPECIFICATIONS AND SOURCES FOR
REPLACEMENT PARTS

OPTIMOD-FM MODEL 8100A/XT
ACCESSORY CHASSIS

Rev 01 2/84

IC's/TRANSISTORS

REF DES	DESCRIPTION	ORBAN P/N	VEN (1)	VENDOR P/N	ALTERNATE VENDORS (1)	QUAN/ SYS.	NOTES
------------	-------------	-----------	------------	------------	--------------------------	---------------	-------

RESISTORS

ALL COMMON RESISTORS NOT SPECIFICALLY LISTED ARE GENERALLY SPECIFIED BELOW:

Replace resistors only with the same style and with the exact value as marked on the resistor body, lest performance or stability be compromised. If the marking is obliterated, refer to the Schematic or consult the factory to obtain the value.

Metal Film Resistors

Body: conformally-coated
 I.D.: five color bands or printed value
 Orban P/N: 20040-XXX
 Power Rating: 1/8 Watt @ 70°C
 Tolerance: 1%
 Temperature Coefficient: 100 PPM/°C
 U.S. Military Spec.: MIL-R-10509, Style RN55D
 Manufacturers: R-0hm (CRB-1/4FX), TRW/IRC, Beyschlag, Dale, Corning, Matsushita

Carbon Film Resistors

Body: conformally-coated
 I.D.: four color bands
 Orban P/N: 20001-XXX
 Power Rating: 1/4 Watt @ 70°C
 Tolerance: 5%
 Manufacturers: R-0hm (R-25), Piher, Beyschlag, Dale, Phillips, Matsushita

Carbon Composition Resistors

Body: molded phenolic
 I.D.: four color bands
 Orban P/N: 20011-XXX
 Power Rating: (70°C) 1/4 Watt (Body 0.090" x 0.250")
 1/2 Watt (Body 0.140" x 0.375")
 Tolerance: 5%
 U.S. Military Spec.: MIL-R-11, Style RC-07 (1/4W) or RC-20 (1/2W)
 Manufacturers: Allen-Bradley, TRW/IRC, Stackpole, Matsushita

Cermet Trimmer Resistors

Body: 3/8" square (9mm)
 I.D.: printed marking on side
 Orban P/N: 20510-XXX
 Power Rating: 1/2 Watt @ 70°C
 Tolerance: 10%
 Temperature Coefficient: 100 PPM/°C
 Manufacturers: Beckman (72PR-series), Spectrol, Bourns, Matsushita

RESISTORS

Board A1

R75	Control, Single, Linear, 10K	20720-000	CTS	270-Series	4
R120	Same as R75 (Board A1)				
R160	Same as R75 (Board A1)				
R168	Same as R75 (Board A1)				

Board A3

R3	Trimpot, Dip, 1 Turn, 100K, 20%	20530-001	BRN	7104D-410-104	6
R31	Same as R3 (Board A3)				
R59	Same as R3 (Board A3)				
R91	Same as R3 (Board A3)				
R119	Same as R3 (Board A3)				
R147	Same as R3 (Board A3)				

FOOTNOTES:

- (1) See last page for abbreviations
 (2) No Alternate Vendors known at publication
 (3) Actual part is specially selected from part listed, consult Factory
 (4) Realignment may be required if replaced, see Circuit Description and/or Alignment Instructions

SPECIFICATIONS AND SOURCES FOR REPLACEMENT PARTS

OPTIMOD-FM MODEL 8100A/XT
 ACCESSORY CHASSIS

Rev 01 2/84

RESISTORS

REF DES	DESCRIPTION	ORBAN P/N	VEN (1)	VENDOR P/N	ALTERNATE VENDORS (1)	QUAN/ SYS.	NOTES
------------	-------------	-----------	------------	------------	--------------------------	---------------	-------

SWITCHES

Board A1

S1	Switch, DPDT	26037-010	CK	7201SYA		1	"PROOF/OPERATE"
----	--------------	-----------	----	---------	--	---	-----------------

MISCELLANEOUS

Chassis

M1	Meter, Edge, 1mADC FS, 950 Ohms	28009-VER	EMI	132D5		6	
M2-6	Same as M1						

P/L REVISIONS

06036-000-02 Final
30760-000-02 VCA, Board A3
30765-000-01 Limiter Control, Board A2
30770-000-01 Crossover, Board A1

J-21

FOOTNOTES:

- | | |
|---|--|
| (1) See last page for abbreviations | (4) Realignment may be required if replaced, see |
| (2) No Alternate Vendors known at publication | Circuit Description and/or Alignment |
| (3) Actual part is specially selected from | Instructions |
| part listed, consult Factory | |

**SPECIFICATIONS AND SOURCES FOR
REPLACEMENT PARTS**

OPTIMOD-FM MODEL 8100A/XT
ACCESSORY CHASSIS

Rev 01 2/84

SWITCHES/MISCELLANEOUS

Vendor Codes

AB	Allen-Bradley Co. 1201 South Second St. Milwaukee, WI 53204	COR	Corcom, Inc. 1600 Winchester Road Libertyville, IL 60048	MAL	Mallory Timers Company Emhart Electrical/Electronic Group 3029 East Washington Street Indianapolis, IN 46206	RCA	RCA Solid State Division Route 202 Somerville, NJ 08876
AD	Analog Devices, Inc. Route 1, Industrial Park P.O. Box 280 Norwood, MA 02062	CTS	CTS Corporation 905 N. West Blvd. Elkhart, IN 46514	MIL	J. W. Miller Division Bell Industries 19070 Reyes Avenue P. O. Box 5825 Compton, CA 90221	SCH	ITT Schadow, Inc. 8081 Wallace Road Eden Prairie, MN 55343
AM	Amphenol North America An Allied Company 2122 York Road Oak Brook, IL 60521	ECI	Electrocube 1710 South Del Mar Avenue San Gabriel, CA 91776	MOT	Motorola, Inc. P. O. Box 20912 Phoenix, AZ 85036	SIE	Siemens Components Division 186 Wood Avenue, South Iselin, NJ 08830
BEK	Beckman Instruments, Inc. Helipot Division 2500 Harbor Blvd. Fullerton, CA 92634	ERE	Erie Technological Products, Inc. 644 West Twelfth Street Erie, PA 16512	NAT	National Semiconductor Corp. 2900 Semiconductor Drive Santa Clara, CA 95051	SIG	Signetics Corporation A Subsidiary of U.S. Philips Corp. P. O. Box 9052 Sunnyvale, CA 94086
BEL	Belden Corporation Electronic Division Richmond, IN 47374	EXR	Exar Integrated Systems, Inc. P. O. Box 62229 Sunnyvale, CA 94088	NOB	Noble Teikoku Tsushin Kogyo Co. Ltd. 335, Kariyado, Nakahara-ku Kawasaki 211, JAPAN	SPR	Sprague Electric Company 125 Marshall Street North Adams, MA 01247
BRN	Bourns, Inc. Trimpot Products Division 1200 Columbia Ave. Riverside, CA 92507	FSC	Fairchild Camera & Instr. Corp. 464 Ellis Street Mountain View, CA 94042	OHM	Ohmite Manufacturing Company A North American Philips Co. 3601 Howard Street Skokie, IL 60076	STK	Stackpole Components Company P. O. Box 14466 Raleigh, NC 27620
BUS	Bussmann Manufacturing Div. McGraw-Edison Company P. O. Box 14460 St. Louis, MO 63178	GI	General Instruments Optoelectronics Div. 3400 Hillview Ave. Palo Alto, CA 94304	ORB	Orban Associates Inc. 645 Bryant Street San Francisco, CA 94107	SYL	Sylvania Connector Prod. Oper. GTE Products Corporation Box 29 Titusville, PA 16354
CD	Cornell-Dubilier Electronics 150 Avenue "L" Newark, NJ 07101	HP	Hewlett-Packard Corporation 1501 Page Mill Road Palo Alto, CA 94304	PAK	Paktron Div. of Illinois Tool Works Inc. 900 Follin Lane, S.E. Vienna, VA 22180	TI	Texas Instruments P. O. Box 225012 Dallas, TX 75265
CK	C & K Components Inc. 15 Riverdale Avenue Newton, MA 02158	INS	Intersil, Inc. 10710 N. Tantau Avenue Cupertino, CA 95014	RAY	Raytheon Semiconductor Division 350 Ellis Street Mountain View, CA 94042	WES	Westlake 5334 Sterling Center Drive Westlake Village, CA 91361
CRL	Centralab Inc. A North American Co. 5757 North Green Bay Ave. Milwaukee, WI 53201	IRC	TRW/IRC Resistors 401 North Broad Street Philadelphia, PA 19108	WIM	WIMA P.O. Box 2345 Augusta-Anlage 56 D-6800 Mannheim 1 Germany		
		LFE	Littelfuse A Subsidiary of Tracor 800 East Northwest Highway Des Plaines, IL 60016				

APPENDIX L: Specifications (Supplementary)

[NOTE: These specifications describe the performance of a system consisting of an 8100A/XT Accessory Chassis and an 8100A/1 Main Chassis interconnected according to instructions provided in this Manual. The specifications in this **Appendix** supersede identically-labelled specifications in **Appendix L** of the **Optimod Operating Manual**. If a given specification is not supplied in this **Appendix**, the specification provided in **Appendix L** of the **Optimod Operating Manual** applies.]

Frequency Response (System in PROOF mode)

Follows standard 75us preemphasis curve ± 1 dB, 50-15,000 Hz. 50us preemphasis available on special order.

Noise

-70dB below 100% modulation, 50-15,000 Hz maximum.

Total System Distortion (PROOF Mode; 100% Modulation)

Less than 0.15% THD, 50-15,000Hz (0.07% typical); less than 0.2% SMPTE Intermodulation Distortion (60/7000Hz; 4:1).

Bass Equalizer

Shape: Peaking
Range: 0 to +10dB boost
Tuning: 80Hz
"Q": 1.4

Crossover Characteristics

Filters: 150Hz lowpass; 420Hz bandpass; 700Hz bandpass; 1.6kHz bandpass; 3.7kHz bandpass; 6.2kHz highpass

Filter Selectivity: 18dB/octave

Filter Topology: parallel, in "distributed crossover" arrangement (U.S. Patent #4,412,100)

Filter Combination:

Static: Outputs of all filters combine to yield static frequency response ± 0.5 dB throughout the range of 50-15,000Hz.

Dynamic: Phase interaction between the filters will not cause audible dips in the frequency response.

Six-Band Limiter Characteristics

Attack Time: Program-controlled; adjusted according to band frequency.

Release Time: Program-controlled; adjusted according to band frequency. Employs delayed release for distortion reduction.

Total Harmonic Distortion (each limiter): Does not exceed 0.1% for any frequency in each limiter's passband with any degree of gain reduction, provided signal is below multiband clipper threshold.

Noise (each limiter): Better than 85dB below VCA output clipping level.

Distortion Cancellation: all clipper-induced distortion in upper two bands cancelled better than 30dB below 2.2kHz. Additional distortion reduction provided as a function of frequency in each band.

Available Gain Reduction (DENSITY control centered): 20dB

Gain Control Element: Proprietary Class-A VCA's.

Indicators

(6) GAIN REDUCTION meters for the Six-Band Limiter.

Setup Controls (front-panel, behind lockable swing-down door)

BASS EQ (L and R)
CLIPPING
DENSITY
ACCESSORY CHASSIS PROOF/OPERATE

Power Requirement

XT Chassis takes ± 15 VDC power from Main Chassis. When XT Chassis is in use, Main Chassis requires 115/230VAC, $\pm 15\%$, 50-60Hz, approx. 40VA.

Dimensions

19"(48.3cm)W x 3.5"(8.9cm)H x 10.8"(27.4cm)D -- 2 rack units

Environmental

Operating Temperature Range: 0-50°C (32-122°F).

Humidity: 0-95% R.H., non-condensing

Warranty

One year, parts and labor. Subject to limitations set forth in our Standard Warranty.

All specifications subject to change without notice.