

Technical Service Manual

Series One

▲ 1100

▲ 1200

▲ 1400

▲ 1700



TD-000040-00

TD-000040-00 REV. A

▲ 1100

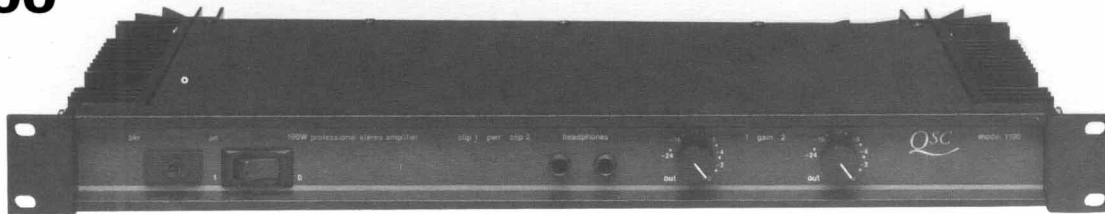

▲ 1200

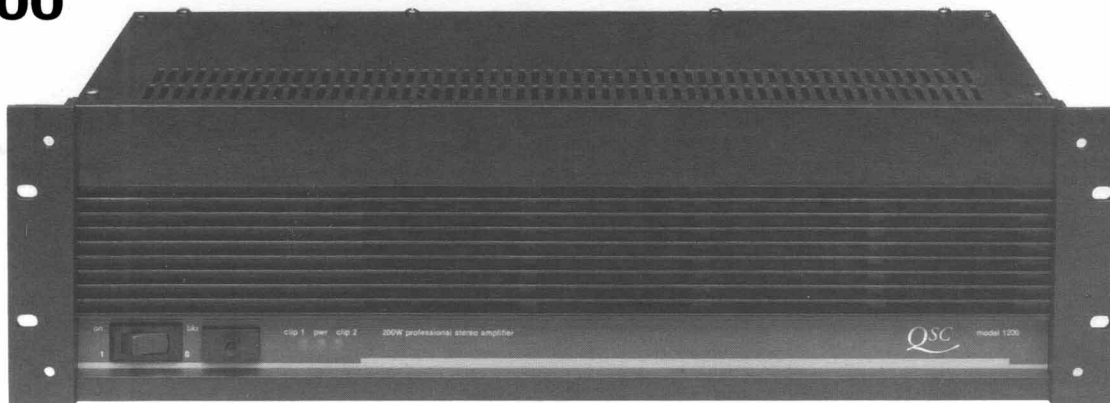

▲ 1400



▲ 1700

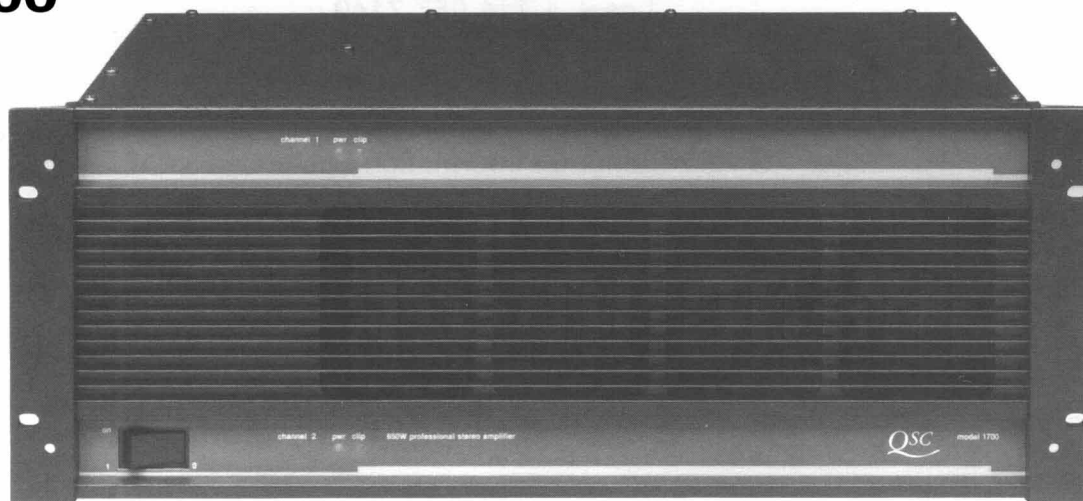



SERIES ONE AMPLIFIER SERVICE MANUAL

1100

1200

1400

1700

QSC Technical Services

Wats: 1-800-772-2834

Local: 1-714-957-7140

Fax: 1-714-754-6173

QSC Technical Services BBS

Online Computer Information System

1-714-668-7567

QSC Audio Products, Inc.

1675 MacArthur Blvd.

Costa Mesa, CA 92626



Table of Contents

Product Specifications	1
Introduction & General Information	2
Series One Test and Calibration	3
Series One Troubleshooting	15
Series One Circuit Description	21
Series One Parts List	
1100 Input Jack Panel	25
1100 Chassis Assembly	25
1100 Main Board Assembly	25
Series One Input Jack Panel	26
1200 Chassis Assembly	26
1200 Main Board Assembly	27
1400 Chassis Assembly	27
1400 Main Board Assembly	28
1700 Chassis Assembly	29
1700 Ch.1 Main Board Assembly	29
1700 Ch.2 Main Board Assembly	30
Semiconductors	32
Chassis Drawings	
1100 Chassis Assembly	33
1200 / 1400 Chassis Assembly	35
1700 Chassis Assembly	38



Wiring Diagrams

<i>1100 Wiring Diagram</i>	40
<i>1200 Wiring Diagram</i>	41
<i>1400 Wiring Diagram</i>	42
<i>1700 Wiring Diagram</i>	43

Schematics

<i>1100 Schematic</i>	44
<i>1200 Schematic</i>	45
<i>1400 Schematic</i>	46
<i>1700 Schematic</i>	47

Printed Circuit Board Layout Traces

<i>1100 Input Jack PCB</i>	48
<i>1100 Main PCB</i>	49
<i>Series One Jack PCB</i>	50
<i>1200 / 1400 Main PCB</i>	51
<i>1700 Ch.1 Main PCB</i>	52
<i>1700 Ch.2 Main PCB</i>	53

1100



1200

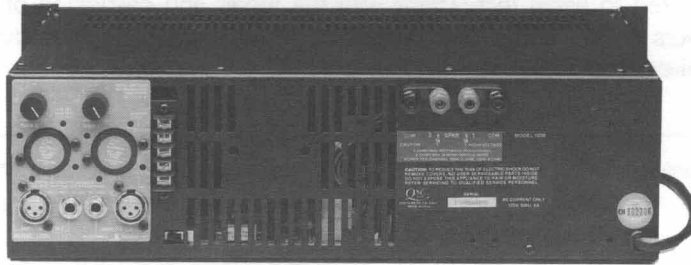

1400

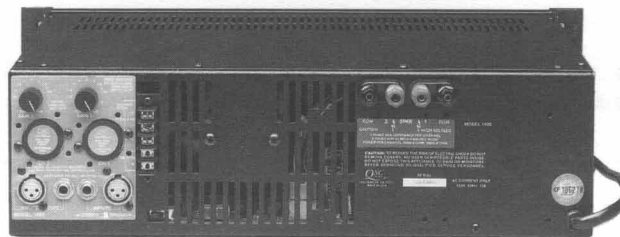

1700

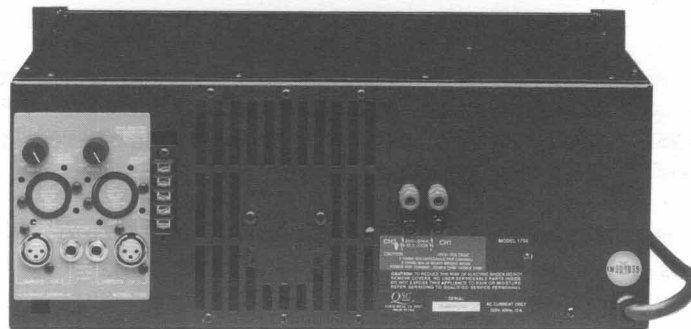

	1100	1200	1400	1700
Output Power (per channel):				
Continuous Average Output Power both channels driven:				
8 ohms, 20Hz - 20kHz, 0.1% THD	50 watts	100 watts	200 watts	325 watts
4 ohms, 20Hz - 20kHz, 0.1% THD	70 watts	150 watts	300 watts	500 watts
Continuous Average Output Power bridged mono operation:				
8 ohms, 20Hz - 20kHz, 0.1% THD	140 watts	300 watts	600 watts	1000 watts
Dynamic Headroom (dB):				
8 ohms	2.0	2.0	2.0	1.9
4 ohms	2.3	2.5	2.5	2.9
Voltage Gain (dB):	26	29	32	34
Distortion, THD @ 8 ohms:				
20Hz - 20kHz, at rated power	Less than 0.1%, 0.01% Typical			
SMPTE-IM at rated power	Less than 0.025%			
Frequency Response	20Hz to 20kHz, +0, -1.0 dB, at 1 watt			
Damping Factor	Greater than 200 @ 8 ohms			
Noise (A weighted)	100dB below rated power			
Sensitivity	1.0 V rms for rated power (8 ohms)			
Input Impedance	10k ohms unbalanced, 20k ohms balanced or unbalanced non inverting			
Dimensions				
Faceplate Width	Standard 19" Rack Mounting			
Faceplate Height	1.75"	5.25"	5.25"	7.0"
Chassis Depth	8.7"	9.5"	9.5"	11.75"
Weight				
Shipping, Lbs/kg	15/6.8	28/12.7	37/16.7	57/25.8
Net, Lbs/kg	12/5.4	24/10.8	34/15.4	55/24.9

I n t r o d u c t i o n

This manual is prepared to assist technicians with the repair and calibration of the Series One audio power amplifiers. The procedures described in this manual require advanced technical experience and sophisticated audio test equipment.

WARNING: *There are **NO** user serviceable components inside these products. Opening these products or attempting the adjustments described in this manual may expose the user to electrical shock. Refer servicing to qualified service personnel.*

Documentation

This manual contains schematics, printed circuit board (PCB) drawings, parts lists, and mechanical assembly drawings. This information should be used in conjunction with the test and troubleshooting guide.

The electrical and electronic components are identified by circuit identification numbers on the schematics and the parts list. The test & troubleshooting sections refer to designations shown in the schematics.

Equivalent Parts

Although many of the electronic components used in this product may be available from electronic suppliers, some components are specially tested and approved by QSC. A product repaired with non-QSC supplied components may not meet factory specifications. Repairs performed using non-QSC parts may void the product warranty. When in doubt, you may contact QSC Technical Services for assistance.

Parts orders to QSC should include the product model number, the part description, and the QSC part number (from the parts list in this manual). Parts will be shipped via UPS, F.O.B. Costa Mesa, California. Shipping, handling and COD charges may be added to the cost of the parts.

Test Equipment

For testing as outlined in this manual, the following equipment will be needed.

Required Test Equipment:

- Distortion Analyzer capable of 0.05% THD+N analysis
- High Power Load Bank (8, 4, & 2 ohm)
- Function Generator
- 20MHz Oscilloscope
- Digital Multimeter
- Variac (0-140 VAC, 10-20A, with AC Current Measuring)

Suggested Test Equipment:

- Audio Precision - System One
- Thermocouple probe

Factory Repair

It may become necessary to return a product to the factory for repair. Call QSC Technical Services for return instructions. You must obtain a Return Authorization number from QSC before returning a product to the factory. QSC Technical Services may be reached at 1 (800) 772-2834.



T e s t & C a l i b r a t i o n

NOTE: This test procedure will refer to the amplifier's channels as CH1 (Channel 1) & CH2 (Channel 2). Component designation will have the suffix "a" for CH1 and "b" for CH2.

Model 1100 Test Procedure

- SET-UP
 1. Connect a test load to the output terminals of the amplifier.
 2. Set the Stereo / Bridge switch to Stereo.
 3. Connect a distortion analyzer with a resolution of 0.05%, 20-20kHz (or better) to the output terminals of the amplifier.
 4. Connect a dual-channel oscilloscope to the following test points:
 - Ch1 - a 10X (vertical sensitivity - 2V/cm) scope probe to the channel speaker output.
 - Ch2 - a 1X scope probe (vertical sensitivity - 0.1V/cm) to the distortion analyzer output.
 5. Set amp gain pots fully clockwise and turn on power switch.
 6. Connect the output of the signal generator to the input terminals of the amplifier and select an output of 1.00 VRMS, 1KHz sine wave.
 7. Lift the ground on the scope and the distortion analyzer.
 8. Plug the amplifier in to a variac and set up an AC line current monitor.

- POWER UP & MUTE DELAY TEST
 1. Slowly raise the variac voltage and watch for excessive current draw (Line current greater than 0.5A a.c. at 120 Volts.) *This is slightly less for 240V.* Pause at 90VAC (200VAC European) for three seconds until the mute / protect circuit disengages. Raise to 120VAC (240V European).
 2. Turn the power switch off and on a few times to verify the 2 - 3 second power-up muting delay. Check both channels.

- CHANNEL OUTPUT
 1. Look for normal signal on the scope of channel 1. Switch the input signal and scope to channel 2 and repeat output test. Check for noisy / contaminated gain pots by observing general instability on your distortion waveform while adjusting the gain control levels.
 2. Select an 8 ohm load and confirm that this product is passing 50 watts at 1kHz just below the point of clipping. Check both channels.

- BRIDGE MODE
 1. Turn the power switch off.
 2. Move the bridge switch on the amp from the Stereo to Bridge position. Turn the gain on CH2 fully counter clockwise (off) and remove the input plug from CH2.
 3. Check CH2 for full output with a 1Vrms sinewave (1kHz) input applied to CH1. The output signal on CH2 should be 180 degrees out of phase with the output signal from CH1.
 4. Turn power off and place the amplifier under test back into the Stereo mode.

• BIAS & RIPPLE (HUM) NULL ADJUSTMENT

HUM NULL:

1. Use 0.1% scale on the distortion analyzer and observe the ripple distortion trace on the oscilloscope.
2. Turn power on and adjust the gain controls on both channels fully clockwise.
3. With an 1Vrms sinewave (1kHz) input, adjust the hum-null trimpot (TR2) for minimum signal distortion.

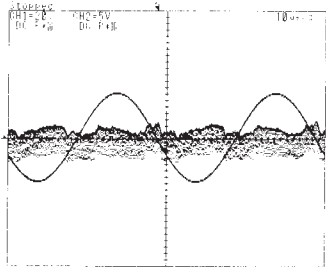

Incorrect Hum Null

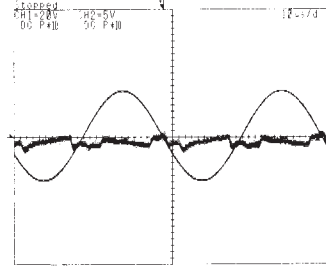

Correct Hum Null

CROSSOVER AND BIAS SETTING:

1. Let the amplifier cool down.
2. With an input amplitude of 1Vrms, increase the input frequency to 20kHz. Reduce the input signal 20dB (80%) from full output and adjust the cross-over trimpot (TR3a) for a less than 400mVpk-pk crossover spike protruding from the noise trace on the oscilloscope. It will be necessary to have the oscilloscope measure an unfiltered distortion from the amplifier under test to be able to see the crossover spike. Set the bias such that the total distortion for that channel is at 0.1%.
3. If a distortion analyzer is not available, a less accurate crossover distortion and bias adjustment can be made by monitoring the driver transistor (Q1 & Q2) bias current. With the amplifier at room temperature, and with no input signal plugged into the amplifier, measure the DC voltage across the emitter resistors of Q1 and Q2 (R15a, R16a). Adjust TR3a to obtain about 80mV d.c. across one of these resistors.
4. Let the amplifier cool down and check channel 2.

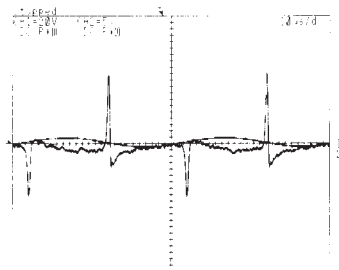

Incorrect Bias

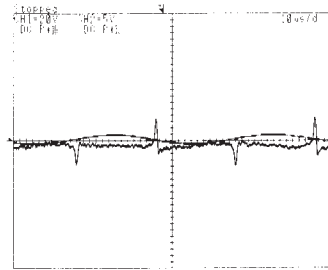

Correct Bias

• SHORT CIRCUIT CURRENT

1. Select a 4 ohm load and apply a 1Vrms sinewave (1kHz) input signal to both channels of the amplifier.
2. While the amplifier is producing power into the loads, apply a short to the output binding posts of each channel. In other words, apply a jumper between the red and black binding posts of each channel. Do not connect the two red binding posts together as this will cause a failure to



occur. Once this is done, combined AC line current draw for both channels should be no greater than 2.5A a.c. .

3. While the amplifier is driving a short, observe the main supply rail voltages. Ideally, they will be no more than 3 volts from each other.
4. Remove the short from each channel and verify that the channels recover in to 4 ohm loads. The output should not experience any hang up and a full sinewave should be present just as it was before a short was applied for this test.

- **FREQUENCY RESPONSE**

1. Set load to 8 ohms and scale your input to gain 1 watt of power from the amplifier on each channel. Gain controls on the amplifier should be fully open.
2. Check frequency response from 20Hz. (+0, -1dB at 1 watt) to 20kHz. (+0, -1dB at 1 watt) by sweeping random frequencies between these extremes. This is done by verifying the same voltage amplitude at each of frequencies selected (within 20Hz to 20kHz). Check both channels.

- **POWER vs. DISTORTION TEST**

1. Check to ensure that both channels will produce rated power at 20Hz, 2KHz, and 20kHz. into an 8 ohm load.
2. While verifying rated power, check that at all frequencies the distortion measurement is less than or equal to 0.1%.

- **THERMAL TEST**

1. Set input frequency to 1KHz and short both channels while they are producing power into a load.
2. AC line current draw should be about 2.0 - 2.5 amps for both channels. As the amplifier gets hot, there will be some current drift upwards. This is not a problem as long as the case temperature on the output transistors do not exceed 105 degrees celcius.
3. Verify that the PTC circuit causes thermal shutdown after an extended period.
4. When thermal shutdown occurs, verify AC idle current of less that 0.75 amperes.

- **CM TEST**

1. Check the Common Mode Rejection of the amplifier by inserting a 1/4" input jack halfway into each channel and observe a 50% signal reduction, and a 180 degrees phase inversion at the output of the amplifier under test.

- **OUTPUT NOISE**

1. Set the amplifier gain to 0 (all the way up), with a 1kHz 1.00Vrms sinewave input signal. Note the output level.
2. Remove the input signal connector from the amplifier and measure the residual noise level produced into the load by the amplifier with an A-weighting filter. The noise signal should be 100 dB down from the full output power point measured. A signal to noise ratio should be better than or equal to 100dB (A weighted). Check both channels.

- **FINAL CHECK**

This completes the electronic test procedure. Inspect the amplifier for mechanical defects. Inspect the solder connections. Reassemble the amplifier and verify the amplifier's operation before returning the product to service.



Model 1200 Test Procedure

- SET-UP
 1. Connect a test load to the output terminals of the amplifier.
 2. Set the Stereo / Bridge switch to Stereo.
 3. Connect a distortion analyzer with a resolution of 0.05%, 20-20kHz (or better) to the output terminals of the amplifier.
 4. Connect a dual-channel oscilloscope to the following test points:
 - Ch1 - a 10X (vertical sensitivity - 2V/cm) scope probe to the channel speaker output.
 - Ch2 - a 1X scope probe (vertical sensitivity - 0.1V/cm) to the distortion analyzer output.
 5. Set amp gain pots fully clockwise and turn on power switch.
 6. Connect the output of the signal generator to the input terminals of the amplifier and select an output of 1.00 VRMS, 1KHz sine wave.
 7. Lift the ground on the scope and the distortion analyzer.
 8. Plug the amplifier in to a variac and set up an AC line current monitor.

- POWER UP & MUTE DELAY TEST
 1. Slowly raise the variac voltage and watch for excessive current draw (Line current greater than 0.75A a.c. at 120 Volts.) *This is slightly less for 240V.* Pause at 90VAC (200VAC European) for three seconds until the mute / protect circuit disengages. Raise to 120VAC (240V European).
 2. Turn the power switch off and on a few times to verify the 2 - 3 second power-up muting delay. Check both channels.

- CHANNEL OUTPUT
 1. Look for normal signal on the scope of channel 1. Switch the input signal and scope to channel 2 and repeat output test. Check for noisy / contaminated gain pots by observing general instability on your distortion waveform while adjusting the gain control levels.
 2. Select an 8 ohm load and confirm that this product is passing 100 watts at 1kHz just below the point of clipping. Check both channels.

- BRIDGE MODE
 1. Turn the power switch off.
 2. Move the bridge switch on the amp from the Stereo to Bridge position. Turn the gain on CH2 fully counter clockwise (off) and remove the input plug from CH2.
 3. Check CH2 for full output with a 1Vrms sinewave (1kHz) input applied to CH1. The output signal on CH2 should be 180 degrees out of phase with the output signal from CH1.
 4. Turn power off and place the amplifier under test back into the Stereo mode.

- BIAS & RIPPLE (HUM) NULL ADJUSTMENT

HUM NULL:

 1. Use 0.1% scale on the distortion analyzer and observe the ripple distortion trace on the oscilloscope.
 2. Turn power on and adjust the gain controls on both channels fully clockwise.
 3. With an 1Vrms sinewave (1kHz) input, adjust the hum-null trimpot (TR2) for minimum signal distortion.

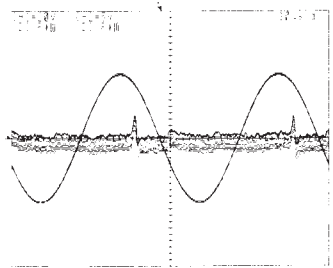

Incorrect Hum Null

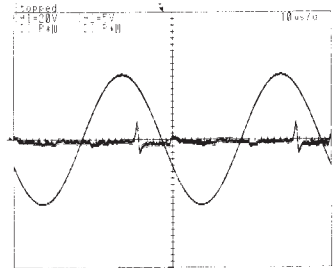

Correct Hum Null

CROSSOVER AND BIAS SETTING:

1. Let the amplifier cool down.
2. With an input amplitude of 1Vrms, increase the input frequency to 20kHz. Reduce the input signal 20dB (80%) from full output and adjust the cross-over trimpot (TR3a) for a less than 400mVpk-pk crossover spike protruding from the noise trace on the oscilloscope. It will be necessary to have the oscilloscope measure an unfiltered distortion from the amplifier under test to be able to see the crossover spike. Set the bias such that the total distortion for that channel is at 0.1%.
3. If a distortion analyzer is not available, a less accurate crossover distortion and bias adjustment can be made by monitoring the driver transistor (Q1 & Q2) bias current. With the amplifier at room temperature, and with no input signal plugged into the amplifier, measure the DC voltage across the emitter resistors of Q1 and Q2 (R15a, R16a). Adjust TR3a to obtain about 80mV d.c. across one of these resistors.
4. Let the amplifier cool down and check channel 2.

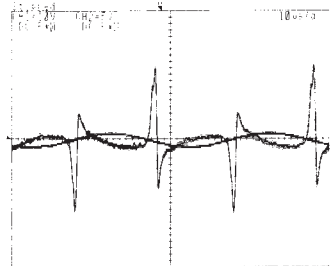

Incorrect Bias

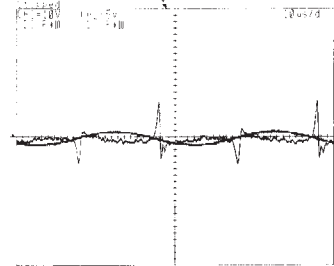

Correct Bias

• **SHORT CIRCUIT CURRENT**

1. Select a 2 ohm load and apply a 1.00Vrms sinewave (1kHz) input signal to both channels of the amplifier.
2. Verify that the gain controls are set to where the amplifier is producing power just beyond clipping.
3. Apply a short to the output binding posts of each channel one channel at a time to adjust the short circuit current limits. Do not connect the two red binding posts together as this will cause a failure.
4. While one channel is driving a short, its AC line current draw for a single channel should be no more than 3.0 A a.c.. (1.5A, 240VAC).
5. TR4a & b is for positive clip adjust and current limiting while TR5a&b is for negative clip adjust and current limiting. If adjustment is necessary to achieve even clipping, a symmetrical

adjustment of the wipers on TR4 and TR5 will be necessary. This balanced adjustment will do two things. It will set the amount of current the amplifier is limited to producing until it goes into thermal protect. It will also establish where the onset of clipping will occur while the amplifier is producing *normal* power into low impedance loads.

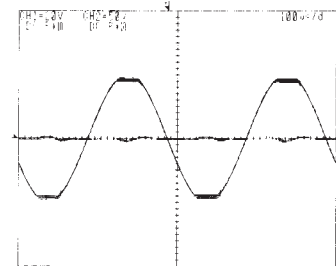

Even Clipping

6. Once even clipping is established and current cutback is set, remove the short from the channel under test to see if it recovers into the 2 ohm load.
7. Perform the same procedure for the next channel to be calibrated.

- 2 OHM POWER

Verify correct loading down to 2 ohms. 2 ohms is allowed to clip somewhat unevenly, but must pass 250W (one channel driven, 1kHz, 1% THD). At this point, verify CLIP and PILOT LED's by adjusting your generator control until the channel is just above clipping.

- FREQUENCY RESPONSE

1. Set load to 8 ohms and scale your input to gain 1 watt of power from the amplifier on each channel. Gain controls on the amplifier should be fully open.
2. Check frequency response from 20Hz. (+0, -1dB at 1 watt) to 20kHz. (+0, -1dB at 1 watt) by sweeping random frequencies between these extremes. This is done by verifying the same voltage amplitude at each of frequencies selected (within 20Hz to 20kHz). Check both channels.

- POWER vs. DISTORTION TEST

1. Check to ensure that both channels will produce rated power at 20Hz, 2KHz, and 20kHz. into an 8 ohm load.
2. While verifying rated power, check that at all frequencies the distortion measurement is less than or equal to 0.1%.

- THERMAL TEST

1. Set input frequency to 1KHz and short both channels while they are producing power into a load.
2. AC line current draw should be about 3.0 - 3.5 amps for both channels. As the amplifier gets hot, there will be some current drift upwards. This is not a problem as long as the case temperature on the output transistors do not exceed 105 degrees celcius.
3. Verify that the PTC circuit causes thermal shutdown after an extended period.
4. When thermal shutdown occurs, verify AC idle current of less that 0.75 amperes.

- CM TEST

1. Check the Common Mode Rejection of the amplifier by inserting a 1/4" input jack halfway into each channel and observe a 50% signal reduction, and a 180 degrees phase inversion at the output of the amplifier under test.

- OUTPUT NOISE

1. Set the amplifier gain to 0 (all the way up), with a 1kHz 1.00Vrms sinewave input signal. Note the output level.
2. Remove the input signal connector from the amplifier and measure the residual noise level produced into the load by the amplifier with an A-weighting filter. The noise signal should be 100 dB down from the full output power point measured. A signal to noise ratio should be better than or equal to 100dB (A weighted). Check both channels.



- FINAL CHECK
This completes the electronic test procedure. Inspect the amplifier for mechanical defects. Inspect the solder connections. Reassemble the amplifier and verify the amplifier's operation before returning the product to service.

Model 1400 Test Procedure

- SET-UP
 1. Connect a test load to the output terminals of the amplifier.
 2. Set the Stereo / Bridge switch to Stereo.
 3. Connect a distortion analyzer with a resolution of 0.05%, 20-20kHz (or better) to the output terminals of the amplifier.
 4. Connect a dual-channel oscilloscope to the following test points:
 - Ch1 - a 10X (vertical sensitivity - 2V/cm) scope probe to the channel speaker output.
 - Ch2 - a 1X scope probe (vertical sensitivity - 0.1V/cm) to the distortion analyzer output.
 5. Set amp gain pots fully clockwise and turn on power switch.
 6. Connect the output of the signal generator to the input terminals of the amplifier and select an output of 1.00 VRMS, 1KHz sine wave.
 7. Lift the ground on the scope and the distortion analyzer.
 8. Plug the amplifier in to a variac and set up an AC line current monitor.
- POWER UP & MUTE DELAY TEST
 1. Slowly raise the variac voltage and watch for excessive current draw (Line current greater than 0.75A a.c. at 120 Volts.) *This is slightly less for 240V. Pause at 90VAC (200VAC European) for three seconds until the mute / protect circuit disengages. Raise to 120VAC (240V European).*
 2. Turn the power switch off and on a few times to verify the 2 - 3 second power-up muting delay. Check both channels.
- CHANNEL OUTPUT
 1. Look for normal signal on the scope of channel 1. Switch the input signal and scope to channel 2 and repeat output test. Check for noisy / contaminated gain pots by observing general instability on your distortion waveform while adjusting the gain control levels.
 2. Select an 8 ohm load and confirm that this product is passing 200 watts at 1kHz just below the point of clipping. Check both channels.
- BRIDGE MODE
 1. Turn the power switch off.
 2. Move the bridge switch on the amp from the Stereo to Bridge position. Turn the gain on CH2 fully counter clockwise (off) and remove the input plug from CH2.
 3. Check CH2 for full output with a 1Vrms sinewave (1kHz) input applied to CH1. The output signal on CH2 should be 180 degrees out of phase with the output signal from CH1.
 4. Turn power off and place the amplifier under test back into the Stereo mode.
- BIAS & RIPPLE (HUM) NULL ADJUSTMENT
HUM NULL:
 1. Use 0.1% scale on the distortion analyzer and observe the ripple distortion trace on the oscilloscope.

2. Turn power on and adjust the gain controls on both channels fully clockwise.
3. With an 1Vrms sinewave (1kHz) input, adjust the hum-null trimpot (TR2) for minimum signal distortion.

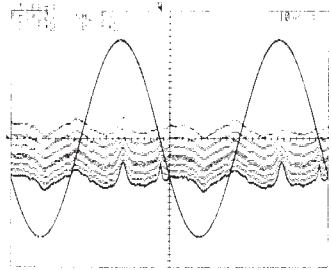

Incorrect Hum Null

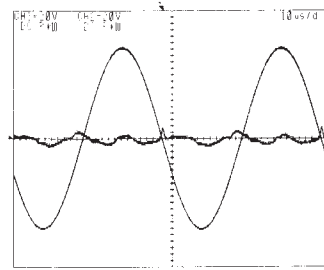

Correct Hum Null

CROSSOVER AND BIAS SETTING:

1. Let the amplifier cool down.
2. With an input amplitude of 1Vrms, increase the input frequency to 20kHz. Reduce the input signal 20dB (80%) from full output and adjust the cross-over trimpot (TR3a) for a less than 400mVpk-pk crossover spike protruding from the noise trace on the oscilloscope. It will be necessary to have the oscilloscope measure an unfiltered distortion from the amplifier under test to be able to see the crossover spike. Set the bias such that the total distortion for that channel is at 0.1%.
3. If a distortion analyzer is not available, a less accurate crossover distortion and bias adjustment can be made by monitoring the driver transistor (Q1 & Q2) bias current. With the amplifier at room temperature, and with no input signal plugged into the amplifier, measure the DC voltage across the emitter resistors of Q1 and Q2 (R15a, R16a). Adjust TR3a to obtain about 80mV d.c. across one of these resistors.
4. Let the amplifier cool down and check channel 2.

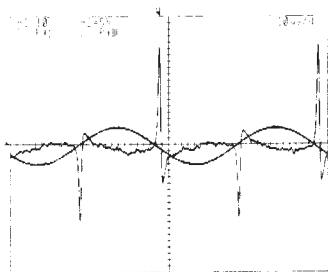

Incorrect Bias

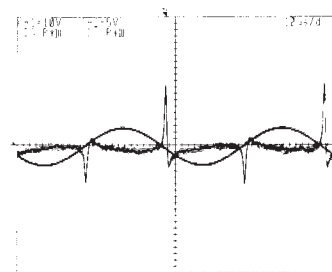

Correct Bias

• **SHORT CIRCUIT CURRENT**

1. Select a 2 ohm load and apply a 1.00Vrms sinewave (1kHz) input signal to both channels of the amplifier.
2. Verify that the gain controls are set to where the amplifier is producing power just beyond clipping.
3. Apply a short to the output binding posts of each channel one channel at a time to adjust the short circuit current limits. Do not connect the two red binding posts together as this will cause a failure.
4. While one channel is driving a short, its AC line current draw for a single channel should be no more than 3.0 A a.c.. (1.5A, 240VAC).

5. TR4a & b is for positive clip adjust and current limiting while TR5a&b is for negative clip adjust and current limiting. If adjustment is necessary to achieve even clipping, a symmetrical adjustment of the wipers on TR4 and TR5 will be necessary. This balanced adjustment will do two things. It will set the amount of current the amplifier is limited to producing until it goes into thermal protect. It will also establish where the onset of clipping will occur while the amplifier is producing *normal* power into low impedance loads.

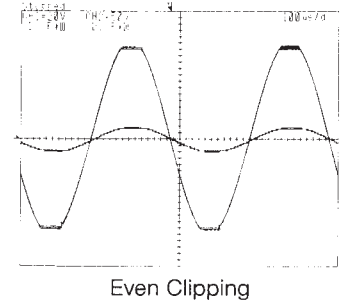

6. Once even clipping is established and current cutback is set, remove the short from the channel under test to see if it recovers into the 2 ohm load.

7. Perform the same procedure for the next channel to be calibrated.

- 2 OHM POWER

Verify correct loading down to 2 ohms. 2 ohms is allowed to clip somewhat unevenly, but must pass 550W (one channel driven, 1kHz, 1% THD). At this point, verify CLIP and PILOT LED's by adjusting your generator control until the channel is just above clipping.

- FREQUENCY RESPONSE

1. Set load to 8 ohms and scale your input to gain 1 watt of power from the amplifier on each channel. Gain controls on the amplifier should be fully open.
2. Check frequency response from 20Hz. (+0, -1dB at 1 watt) to 20kHz. (+0, -1dB at 1 watt) by sweeping random frequencies between these extremes. This is done by verifying the same voltage amplitude at each of frequencies selected (within 20Hz to 20kHz). Check both channels.

- POWER vs. DISTORTION TEST

1. Check to ensure that both channels will produce rated power at 20Hz, 2KHz, and 20kHz. into an 8 ohm load.
2. While verifying rated power, check that at all frequencies the distortion measurement is less than or equal to 0.1%.

- THERMAL TEST

1. Set input frequency to 1KHz and short both channels while they are producing power into a load.
2. AC line current draw should be about 3.5 - 4.0 amps for both channels. As the amplifier gets hot, there will be some current drift upwards. This is not a problem as long as the case temperature on the output transistors do not exceed 105 degrees celcius.
3. Verify that the PTC circuit causes thermal shutdown after an extended period.
4. When thermal shutdown occurs, verify AC idle current of less that 0.75 amperes.

- CM TEST

1. Check the Common Mode Rejection of the amplifier by inserting a 1/4" input jack halfway into each channel and observe a 50% signal reduction, and a 180 degrees phase inversion at the output of the amplifier under test.

- OUTPUT NOISE

1. Set the amplifier gain to 0 (all the way up), with a 1kHz 1.00Vrms sinewave input signal. Note the output level.
2. Remove the input signal connector from the amplifier and measure the residual noise level produced into the load by the amplifier with an A-weighting filter. The noise signal should be

100 dB down from the full output power point measured. A signal to noise ratio should be better than or equal to 100dB (A weighted). Check both channels.

- FINAL CHECK

This completes the electronic test procedure. Inspect the amplifier for mechanical defects. Inspect the solder connections. Reassemble the amplifier and verify the amplifier's operation before returning the product to service.

Model 1700 Test Procedure

- SET-UP

1. Connect a test load to the output terminals of the amplifier.
2. Set the Stereo / Bridge switch to Stereo.
3. Connect a distortion analyzer with a resolution of 0.05%, 20-20kHz (or better) to the output terminals of the amplifier.
4. Connect a dual-channel oscilloscope to the following test points:
 - Ch1 - a 10X (vertical sensitivity - 2V/cm) scope probe to the channel speaker output.
 - Ch2 - a 1X scope probe (vertical sensitivity - 0.1V/cm) to the distortion analyzer output.
5. Set amp gain pots fully clockwise and turn on power switch.
6. Connect the output of the signal generator to the input terminals of the amplifier and select an output of 1.00 VRMS, 1KHz sine wave.
7. Lift the ground on the scope and the distortion analyzer.
8. Plug the amplifier in to a variac and set up an AC line current monitor.

- POWER UP & MUTE DELAY TEST

1. Slowly raise the variac voltage and watch for excessive current draw (Line current greater than 1.1A a.c. at 120 Volts.) *This is slightly less for 240V. Pause at 90VAC (200VAC European) for three seconds until the mute / protect circuit disengages. Raise to 120VAC (240V European).*
2. Turn the power switch off and on a few times to verify the 2 - 3 second power-up muting delay. Check both channels.

- CHANNEL OUTPUT

1. Look for normal signal on the scope of channel 1. Switch the input signal and scope to channel 2 and repeat output test. Check for noisy / contaminated gain pots by observing general instability on your distortion waveform while adjusting the gain control levels.
2. Select an 8 ohm load and confirm that this product is passing 325 watts at 1kHz just below the point of clipping. Check both channels.

- BRIDGE MODE

1. Turn the power switch off.
2. Move the bridge switch on the amp from the Stereo to Bridge position. Turn the gain on CH2 fully counter clockwise (off) and remove the input plug from CH2.
3. Check CH2 for full output with a 1Vrms sinewave (1kHz) input applied to CH1. The output signal on CH2 should be 180 degrees out of phase with the output signal from CH1.
4. Turn power off and place the amplifier under test back into the Stereo mode.



• BIAS ADJUSTMENT

1. Let the amplifier cool down.
2. With an input amplitude of 1Vrms, increase the input frequency to 20kHz. Reduce the input signal 20dB (80%) from full output and adjust the cross-over trimpot (TR1a) for a less than 400mVpk-pk crossover spike protruding from the noise trace on the oscilloscope. It will be necessary to have the oscilloscope measure unfiltered distortion from the amplifier under test to be able to see the crossover spike. Set the bias such that the total distortion for that channel is at 0.1%.
3. If a distortion analyzer is not available, a less accurate crossover distortion and bias adjustment can be made by monitoring the driver transistor (Q1 & Q2) bias current. With the amplifier at room temperature, and with no input signal plugged into the amplifier, measure the DC voltage across the emitter resistors of Q1 and Q2 (R12a, R13a). Adjust TR1a to obtain about 80mV d.c. across one of these resistors.
4. Let the amplifier cool down and check channel 2.

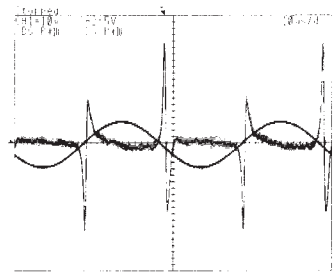

Incorrect Bias

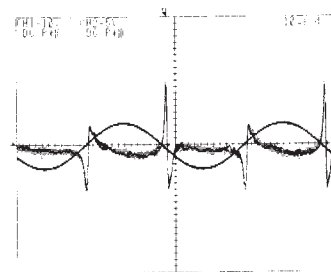

Correct Bias

• SHORT CIRCUIT CURRENT

1. Select a 2 ohm load and apply a 1.00Vrms sinewave (1kHz) input signal to both channels of the amplifier.
2. Verify that the gain controls are set to where the amplifier is producing power just beyond clipping.
3. Apply a short to the output binding posts of each channel one channel at a time to adjust the short circuit current limits. Do not connect the two red binding posts together as this will cause a failure.
4. While one channel is driving a short, its AC line current draw for a single channel should be no more than 5.5 A a.c.. (2.5A, 240VAC).
5. If a current limiting adjustment is necessary, TR2 will set the amount of acceptable AC line current.
6. Also during the time the channel is driven into a short, measure the main +/-93 volt rails. They should be within 3 volts of each other (notwithstanding the polarities). If they are not balanced, adjust TR3 to get the proper balancing between the two rails. This balance adjustment will establish where the onset of clipping will occur while the amplifier is producing *normal* power into low impedance loads.
7. Once even clipping is established and current cutback is set, remove the short from the channel under test to see if it recovers into the 2 ohm load.
8. Perform the same procedure for the next channel to be calibrated.

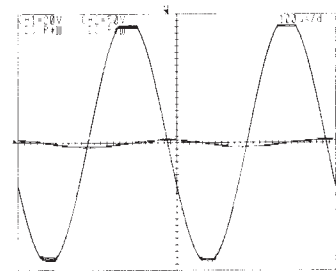

Even Clipping



- **2 OHM POWER**

Verify correct loading down to 2 ohms. 2 ohms is allowed to clip somewhat unevenly, but must pass 1000W (one channel driven, 1kHz, 1% THD). At this point, verify CLIP and PILOT LED's by adjusting your generator control until the channel is just above clipping.
- **FREQUENCY RESPONSE**
 1. Set load to 8 ohms and scale your input to gain 1 watt of power from the amplifier on each channel. Gain controls on the amplifier should be fully open.
 2. Check frequency response from 20Hz. (+0, -1dB at 1 watt) to 20kHz. (+0, -1dB at 1 watt) by sweeping random frequencies between these extremes. This is done by verifying the same voltage amplitude at each of frequencies selected (within 20Hz to 20kHz). Check both channels.
- **POWER vs. DISTORTION TEST**
 1. Check to ensure that both channels will produce rated power at 20Hz, 2KHz, and 20kHz. into an 8 ohm load.
 2. While verifying rated power, check that at all frequencies the distortion measurement is less than or equal to 0.1%.
- **THERMAL TEST**
 1. Set input frequency to 1KHz and short both channels while they are producing power into a load.
 2. AC line current draw should be about 3.5 - 4.0 amps for both channels. As the amplifier gets hot, there will be some current drift upwards. This is not a problem as long as the case temperature on the output transistors do not exceed 105 degrees celcius.
 3. Verify that the PTC circuit causes thermal shutdown after an extended period.
 4. When thermal shutdown occurs, verify AC idle current of less that 0.75 amperes.
- **CM TEST**
 1. Check the Common Mode Rejection of the amplifier by inserting a 1/4" input jack halfway into each channel and observe a 50% signal reduction, and a 180 degrees phase inversion at the output of the amplifier under test.
- **OUTPUT NOISE**
 1. Set the amplifier gain to 0 (all the way up), with a 1kHz 1.00Vrms sinewave input signal. Note the output level.
 2. Remove the input signal connector from the amplifier and measure the residual noise level produced into the load by the amplifier with an A-weighting filter. The noise signal should be 100 dB down from the full output power point measured. A signal to noise ratio should be better than or equal to 100dB (A weighted). Check both channels.
- **FINAL CHECK**

This completes the electronic test procedure. Inspect the amplifier for mechanical defects. Inspect the solder connections. Reassemble the amplifier and verify the amplifier's operation before returning the product to service.



T r o u b l e s h o o t i n g

Current Draw

(Circuit breakers and fuses blow. Burning smell or smoke)

Symptoms:

All Models

- Fuses immediately blow
- Amplifier quickly gets very hot
- Line circuit breakers tripping upon turn on
- Amplifier exhibits very loud hum with chassis vibration
- Amplifier emits smoke
- A burning smell is emanating from the amplifier

Possible Causes:

All Models

- **EXCESSIVE CURRENT WITHOUT SIGNAL PRESENT**
The amplifier draws high current when the AC supply voltage is first applied up (with signal but no load). This symptom means there is a short in the power stages of the circuit. It is possible to lift the fuse for each channel to isolate the problem to one channel (the 1700 has two fuses per channel). This could also show a misadjusted bias setting. See calibration procedures in this manual for setting bias.
- **FAST CURRENT DRAW** (increases rapidly at only a few volts AC voltage):
 1. Reversed or shorted main bridge rectifier B1.
 2. Both supply clamping diodes D6, D7 reversed or shorted
 3. Both polarities output transistors or drivers shorted.
- **MEDIUM CURRENT DRAW** (increases slowly, can go to 30 VAC before current becomes excessive.):
 1. Single polarity driver or output short.
 2. Single supply clamping diode D6 or D7 reversed or shorted.
 3. Open or missing bias diodes D1, D2 or bias trim pot TR3 and R38.
- **SLOW CURRENT DRAW** (above 60 volts AC before current begins to increase, amp may pass signal).
 1. Severely misadjusted bias circuit or defective bias diodes D1-2.
 2. Severe oscillation causing current drain.
- **RUNAWAY CURRENT DRAW** (30-40V AC before current begins to increase or runaway):
 1. A reversed filter capacitor: caution, may vent explosively.

Protection, Muting Circuit and Power On/Off Delay

(The amplifier locks up or does not startup and shut off correctly)

Symptoms:

Models 1100, 1200, & 1400

- Both channels do not come out of protect
- Amplifier will not thermally protect
- Pilot LED not working
- Too little or too much muting delay

Model 1700

- Relay won't turn on
- Poor mute circuit timing
- No thermal shutdown
- No Red protect LED
- No D.C. protect
- Shuts off under signal

Possible Causes:

Models 1100, 1200, & 1400

- BOTH CHANNELS DO NOT COME OUT OF PROTECT
Q11 or Q12 shorted base emitter
Voltage on Z5 should be 14v - 15v. If this voltage is low, check for leaky E8, E9, defective Z5, or open R33.
Check for open LD3 and open PTC.
- AMPLIFIER WILL NOT THERMALLY PROTECT
Check for shorted LD3 and PTC, incorrect R35, R34, open pilot LD2, or open R39.
- MUTING DELAY
Too Much: Check for open LD2 or R39, incorrect R33, R34, R35 or shorted LD3.
Too Little: Check for incorrect E8, E9, or R33.
- PILOT LED NOT WORKING
Check for shorted or open pilot LD2. Check R39.

Possible Causes:

Model 1700

- RELAY WON'T TURN ON
Check speaker bus for DC; if over 10V DC is present, the protect circuit is operating normally to prevent operation. If DC is present, (presumably without current draw), continue below; if no DC is present on the output, skip to the section below other protection related faults.
Check relay power voltage. With relay off, voltage at E5 should measure 36V (set by Zener Z6). If not check R31, D9, or shorted Z6.
If power voltage is OK, check voltage on timing capacitor E4. Should rise to 12-15V, in three seconds, which triggers Q19. If not, check R19, R20, E4's polarity, or for a shorted Q20.
If timing voltage is OK, check relay transistor Q21. If good, a 47K resistor from base to speaker bus should activate relay.
If relay driver Q21 is OK, check driver Q19 and LED LD3.
- POOR MUTE CIRCUIT TIMING



NO MUTING DELAY (*relay or circuit is "stuck on"*)

Relay driver Q21 shorted or wrongly mounted. Check by jumping base to emitter, should turn it off if OK.

Driver Q19 shorted or wrongly stuffed (check by jumping base to emitter as above).

D7 reversed (charges timing capacitor E7 immediately)

R20 low (fast E4 charge)

R19 low (low voltage on E4 turns Q19 on too soon)

Missing or high R23 (no off current)

EXCESSIVE MUTING DELAY

Check timing capacitor E4 voltage. If it rises normally but circuit is slow to turn on, check Z7 (lift temporarily while checking circuit), LD3 bad or intermittent, R23 too low.

Timing capacitor voltage wrong; check for R19, R20, reversed E4, missing R22.

Reversed or wrong Q20 type.

- NO D.C. PROTECT

DC FAULT WITHOUT CURRENT DRAW. In most cases, shorts in the output circuit will cause current draw, but certain shorts will only cause DC offset in the output. In both cases, measure the various circuit voltages, and look for abnormal values to help trace the fault, which can be a solder or component short (zero volts), reversed zener or diode (.6V) reversed electrolytic (several volts), or wrong value parts (abnormal voltage). Look at the following points in the circuit.

Shorted IC rail, sometimes both shorted together; including input cable connectors and jacks

Defective Z2-3 gives zero volts on IC rail.

Collector-base short on driver (rare without further damage)

Sometimes IC forces the rest of the circuit into DC due to shorts in the feedback network, etc.

To check this, remove IC, check for +15V, -15V on IC rails, and balanced voltages in the drivers and outputs. If so, output stage is probably OK, look for problems in IC, or its associated parts.

Defective or reversed IC (pull and check voltages).

R30 missing or very high.

B2 defective or wrongly mounted on PCB.

Q20 defective or wrong type.

D7 reversed (also no muting delay).

Replace LD-3 if voltage drop across it is less than 1.5V.

- SHUTS OFF UNDER SIGNAL

E6 missing, defective, or much too small.

- NO RED PROTECT LED

Check LED voltage. If over +2V, LED is defective. If 0V with relay off (meaning no positive voltage to LED), check for solder short, or there is no "protect" power, (missing R29), which defeats shut-down circuits. Be sure to correct before proceeding.

- NO THERMAL SHUTDOWN

Short amplifier load with full signal to raise heat sink temperature and put voltmeter across PTC, (yellow sensor on heat sink), looking for voltage across PTC to rise from .7V cold to about 5.5V at shutdown.

No Red "Protect", may have no R29, which defeats whole thermal circuit (no voltage across PTC). If the PTC reaches 6V but won't shut down, check Z7, or relay drive circuit stuck on (see above). If red "protect" /R12 is OK, but no voltage across PTC, then the PTC is defective or shorted (lift temporarily or replace with 10K pot, confirm shutdown).

Faults with Signal Present

(The amplifier passes a signal but is not running correctly)

Symptoms:

All Models

- Output power "breaking up"
- 'Ringing' sound with no input to amplifier
- Output collapses into a 8, 4, or 2 ohm load
- Voltage rails ok without signal
- Amplifier gets too hot
- One channel clips prematurely
- Excessive hum with no input to amplifier

Possible Causes:

All Models

- OUTPUT POWER "BREAKING UP" (*Output distorted*)
Hum-null components may have burned open. Check R7, R8 and TR2.
Ground traces may be bad. Check for continuity between speaker ground, input ground and ac ground.
- "RINGING" SOUND WITH NO INPUT TO AMPLIFIER
C2 and/or C4 (C4, C7, 1700) may be bad.
Check op amp IC1.
- OUTPUT COLLAPSES INTO A LOAD
No continuous ground between main pcb to heatsink through pem stud. The spring tooth lock washer may not be biting through anodized surface on main heatsink.
Misadjusted TR4 or TR5.
Check for R20 and R21.
- VOLTAGE RAILS OK WITHOUT SIGNAL *Collapses with a signal*
E2 or E3 leaking.
Check for capacitance value of C2 and C4 (C7, C13, E1, 1700).
- AMPLIFIER GETS TOO HOT WITHOUT LOAD
TR3 (TR1, 1700), misadjusted, opened or burned.
Incorrect bias diode (should be 1N4934) D1, D2 (D5, D6, 1700).
Missing C2 or C4 (C4, C7, 1700). High frequency oscillations evident.
Open R17, R18 (R16, R17, 1700).
Defective op amp IC1. Unstable and generating high frequencies).
- ONE CHANNEL CLIPS PREMATURELY
R15 or R16 may be open.
Misadjusted TR4 & TR5.
Into a 4 ohm load, check for open R22, or open D4 & D5 (D1 & D2, 1700).
Check R7 & R8 for open or incorrect value.
Check for open R12, R13, R20, R21 (R14, R15, R52, R53, 1700)
450 ohm chargeback resistor R22 may be open.
Check for open on D4 and D5.
- EXCESSIVE HUM WITH NO INPUT TO AMPLIFIER
TR2 (hum-null trim potentiometer) misadjusted, opened or burned.
Check for mismatched capacitance value of output filter capacitors.



Instability

(Gain problems, spurious noises, and oscillations)

Symptoms:

All Models

- General Output Distortion
- 'Ringing' sound with no input to amplifier
- Excessive or unbalanced crossover
- Output waveform appears "fuzzy"

Possible Causes:

All Models

First, distinguish between instability (fuzziness), "ringing" which is momentary instability after a transition, "step" distortion, crossover distortion (both often show ringing), or general distortion.

- GENERAL OUTPUT DISTORTION

SEVERE:

All loads, often with current draw: usually very low or missing slew rate capacitor C4, or feedback capacitor C2.

MEDIUM:

Especially with a light load, often too high a value of a stability capacitor; check feedback capacitor C2, secondary stability capacitors C9, (C5,6 1700); and output filter R32/C5 (1700-R27,28/C10). Jump with comparable value, if better, replace with increased value, if worse, try replacing with 50% lower value).

LOW GAIN:

Suspect open circuit in feedback shunt R5 (1700-R7/E1). Check for broken circuit trace. Substitute IC, and check IC socket for contamination.

- "RINGING" SOUND WITH NO INPUT TO AMPLIFIER

Usually indicates marginal instability, usually triggered after passing through the crossover. Can indicate problem in "minor" stability components. Also check output filter. Possibly the crossover is larger than usual.

- EXCESSIVE OR UNBALANCED CROSSOVER (*Excess notch or ringing at zero crossing*)

Severe: shorted bias diode D1-2 (D5, D6, 1700).

Moderate: Out-of-spec bias diodes.

Defective bias trimmer components TR3 (TR1, 1700) and R38 (R54, 1700).

Check for open base resistors R17,18 (R16, R17, 1700) on output devices.

- OUTPUT WAVEFORM APPEARS "FUZZY"

Instability on one side of the waveform:

Add .015uF trimmer bypass capacitor around bias trimmer TR3 (TR1, 1700).

Check/adjust driver emitter capacitors C8 and C9 (C5,6 on 1700).

Power Supply and Voltage Rail Balancing

(Uneven rails and power supply problems)

Symptoms:

All Models

- Current limiting wrong
- Current limiting too high into a short
- IC rail too high into a short
- Current limiting too low into a short
- Uneven voltage rails

Possible Causes:

All Models:

- CURRENT LIMITING WRONG
Current limits should remain high down to 2 ohms, and collapse to a lower value for short circuits. This is caused by the IC rails going from normal 14 - 15 volts to about 5-6 volts. Current limit trimmers TR4 & TR5 (TR2 on 1700) permits adjustment of each channel to specified range. See Test & Calibration Procedures for correct adjustment of the current limiting.
- CURRENT LIMITING TOO HIGH INTO SHORT (*IC RAILS CHECK NORMAL 5-6 volts*)
Reversed or shorted 3.9 or 4.7V zeners Z15, Z16.
Shorted bias diode D1,2 (also shows severe crossover), (D5, 6, 1700).
- IC RAIL TOO HIGH INTO SHORT
Check op amp (weak output current).
Clip LED open.
B2 defective, (B1, 1700)
Check for short circuit current balance on the 1200 and 1400 by measuring the main rail voltages during short circuit; they should be balanced within 3V. If severely offset, check Z3 (3.9V) and Z4 (4.7V) for correct voltage, and check values of R15 and R16.
- CURRENT LIMITING TOO LOW INTO SHORT AND 2 OHM LOAD
IC RAILS OK
Bias resistor R12, R13 high.
Very low gain driver transistors (see below).
Missing connection or emitter resistors in some of the paralleled output transistors.
- CURRENT LIMITING TOO LOW INTO SHORT ONLY (*OK into normal loads*)
Check Clip LED shorted, 1.5A rectifier B1 shorted.
3.9 or 4.7V zeners high (7.5V or 15V).
- OK INTO SHORT BUT LOW INTO 2 OHMS: (*Usually on one side only*)
IC RAIL LOW (driving two ohms even before clipping): check for high or missing charge-back R22 (1700-R49), or missing/reversed charge-back diodes D4 or D5 (usually causes premature clipping at 4 ohms as well).
IC RAIL OK (until clipping starts) usually indicates low output section gain caused by weak driver, open output devices, or open emitter resistors. Also check value of driver emitter resistors R15, R16.
- UNBALANCED RAIL VOLTAGES: (*1200 and 1400*)
Rail voltage is determined by R7 and R8 from the positive and negative rails.
If the amplifier is passing a signal but clipping unevenly due to uneven rail voltages, check and replace R7,8 (47K, 1watt, Metal Oxide).

C i r c u i t D e s c r i p t i o n

This circuit description pertains to the 1400 amplifier which in turn corresponds to the model 1200. Reference designators given on the schematics can be referred to in order to make comparisons when reviewing this description. Refer to the appropriate schematic when following the description given on the coming pages.

Power Supply

AC Power comes in through a thermal (slow-blow) circuit breaker and AC switch. A row of terminals on the main circuit board allows the transformer primary to be wired in parallel for 120V, 60Hz operation, or in series for 220V, 50Hz operation. Transformer excitation current will rise to the limit at 240V, 50Hz, which may increase AC hum in the amplifier. Also, note that there will be an 8% voltage reduction at 220V (110V volts per primary section) compared to 120V operation. This results in a 15% loss of amplifier power but increases transformer capacity for the primary US market.

The fan speed is controlled by R42, a 250 ohm, 15W resistor and a 55C thermostat. With the resistor in series, the fan operates at about half speed. When heat sink temperatures exceed 55C, the thermostat clicks in and bypasses the resistor, giving full voltage to the fan.

The transformer has independent secondary windings for each channel. Each channel has its own filter capacitors (E4, 5, 6, 7) and power rectifier (B1). A fault fuse (F1) is located prior to the rectifier to disconnect a faulty channel. The current rating of the fuse, 12A, is high enough to carry the maximum current of a properly operating channel, even into a short circuit, so the fuse should only blow in case of an actual fault (i.e. shorted output transistor).

There are two unusual features of the QSC power supply circuit. First, while we use conventional positive and negative filter capacitors, for a balanced bipolar power supply, there is no return from the center point to the center-tap of the power transformer. This means that the center voltage of the two capacitors is free to float. Since audio currents have no average DC content, equal power is drawn off both capacitors, and the positive and negative voltages remain equal. This is assisted by feedback circuits described below. However, if the amp develops a DC fault, such as a power transistor short to one of the rails, no long-term DC can flow to the load. Instead, the voltage on the capacitors becomes unbalanced, and the "DC fault" is blocked. The net effect is the same as adding a bipolar output capacitor, without and added expense.

The second unusual feature is that we reverse the usual location of the speaker and ground terminals. For reasons explained in following sections 4 and 5, we ground the common collectors of the output transistors, and take the audio output from the midpoint of the power supply capacitors. This requires separate filters, rectifiers, and transformer secondaries for each channel, but results in minimal cross-talk, and permits one channel to fail without affecting the other.

The bipolar 15V rails for the op amp are derived using dropping resistors (R20 and R21) and zener stabilizers (Z1 and Z2) from the main rails. The op-amp supply rails are involved in our short-circuit protection scheme, as described in a following section.

Balanced Input Circuit, Gain, & Frequency Limits

The first stage of the dual op-amp is used as a differential input. Matched precision resistive dividers R1/R3, and R2/R4, are arranged so that any signal appearing equally on both the positive and negative inputs results in no voltage across the op-amp input terminals, and no voltage at the output of the op-amp. In other words, noise signals which normally occur equally on both sides of the balanced line are rejected. The audio signal appears as a difference between the balance-line conductors, and these signals are picked up and appear at the same gain at the output of the op-amp. For unbalanced inputs, either input line may be grounded, and the circuit will respond at unity gain to the other line. For reasons of overall stability in actual use, QSC uses the inverting input for unbalanced signals.

After balanced-to-unbalanced conversion, the audio signal flows through a 4.7 μ F NP (E1), for low frequency rolloff (-3dB at 8Hz), with the 4.7k outboard resistors (R11 and one mounted on jack panel) gives a uniform attenuation slope as calibrated on the Gain control label. Finally, R10 and C1 establish a high frequency rolloff (-3dB at 75kHz). The net audio response is typically down less than 0.5dB from 20 - 20kHz.

Feedback, Gain Stage, Clip, and Short Circuit Protection

The actual power amplifier begins at the second stage of the op-amp. Audio feedback is established across R6, from the speaker, and R5 to ground. DC feed back to keep the rail voltages equal is established by matched resistors R7 and R8. If the filter capacitors are slightly mismatched, ripple on the positive and negative supplies are unequal and hum can appear at the output during large signal loading. A "hum null" trim, R9, C3, and TR2, allows this to be canceled out.

High frequency stability is established by C4 and C2. C4 is the primary "phase lag" capacitor, which sets slew rate and thus the overall "speed limit" of the circuit. C2 establishes "phase lead" in the speaker feedback network, increases feedback at very high frequencies and thus improves control at frequencies where oscillations might occur. C7, at the output of the op-amp, and L1, R31, R32, and C5, at the speaker output, and C9 (in later versions only) further improve stability.

Most of the gain in the amplifier is contribute by the second stage of the op-amp. This stage's primary job is to feed the driver transistors, but is also used to drive the Distortion LED (LD1) and is tied in to the short circuit protection scheme.

As long as the output of the amp is not clipping, the drive voltage to the bases of the driver transistors, Q1 and Q2, remains below 1.5 volts peak. If the amp clips, the op-amp will attempt to overcome this by instantly delivering a higher than normal voltage to the drivers. This excess voltage is used to driver the distortion (clip) LED, which requires a voltage in excess of about 2 volts to operate. Thus any form of clipping immediately results in illumination of the distortion LED.

One of the feature advantages of the QSC circuit is our effective short circuit protection., In order to maintain good audio performance into low impedance loads, it is necessary to maintain a high output current limit. The normal current limit is determined by the base current to each driver through 1K resistors and 3.9V zener diodes (R12/Z3, and R13/Z4). When the op-amp rails are at their normal 15V, this current is about 9ma, and results in about 20A of output current. This is sufficient to deliver rated power into a two ohm load. The output transistors can withstand this much current into a short for a few seconds, but would overheat and fail before thermal shutdown can occur. Therefore, we need a method of reducing current into shorts without affecting normal operation.

The normal range of currents from the op-amp is less than the current supplied from the main power supply rails by R20 and R21. However, as full power is reached, and especially if the amp is clipped and the op-amp has to deliver extra current to the distortion LED, more current is drawn than these

resistors can supply, and the op-amp rail voltage would normally be drawn down. To prevent this, we have a replenishing circuit, from the speaker output voltage, through R22 and rectifiers D4 and D5. As long as the load impedance is above 2 ohms, there will be enough output voltage to recharge the op-amp rails through this network. If the output is shorted, however, the output voltage will be clamped to a low value, recharging will not occur, and the op-amp will deplete its supply rails to about 6 volts. This will cut the current to the drivers drastically (through R12 and R13), and reduces output current to a safe level which the amp can withstand until thermal shutdown occurs. The exact short-circuit current is adjusted by trimpots TR4 and TR5, which varies the voltage drop between the op-amp and the driver transistors, ultimately determining the maximum depletion of the op-amp rails.

Bridged-mono operation requires that channel 2 operates at the same level but out-of-phase with channel 1. This is achieved by connecting the output from channel 1 through the bridge switch and R19 into the inverting input of channel 2. R19's value matches that of the feedback network, for unity gain in Ch.2. Since Ch.2's gain control is bypassed, the gain for Ch.1 controls the entire signal, and equal signal in both channels is assured.

Driver Transistors and Crossover Biasing

The problem now becomes to amplify the low voltage and current from the op-amp to the full power of the amplifier. We can do this with only two stages of discrete transistors by using careful design.

Complementary drivers Q1 and Q2 are connected to the op-amp through bias diodes D1 and D2. The forward voltage drop of the diodes matches the forward base voltage of Q1 and Q2, so that as the op-amp swings on either side of zero, it immediately drives Q1 or Q2. This eliminates a "dead zone" which would cause crossover distortion. The bias trimpot TR3 was added in series with D1 and D2 to permit the bias to be fine tuned. Emitter resistors R15 and R16 are used to stabilize the gain of Q1 and Q2, and to minimize any tendency to draw more idle current as they heat up. These resistors drop about 1.5 volts at full current, which reduces the output power slightly. The final collector current from Q1 and Q2 is about 500ma, and goes to the bases of the output transistors.

Complementary Output Transistors

The emitters of the positive and negative output transistors (Q3, 4, 5, 6 and Q7, 8, 9 10) are connected to the main rails through load-sharing emitter resistors R23, 24, 25, 26 and R27, 28, 29, 30. The parallel bases of each bank are bypassed with 22 ohm resistors R17 and R18, which assure positive shut off of the outputs. The 500ma currents from the collectors of Q1 and Q2 are connected to the output transistor bases and amplified to about 20A peak.

Note that the collectors of all output transistors meet at a common ground. This is possible because of the special power supply arrangement outlined earlier. This means we can simply screw the cases to a grounded heat sink, with no need for the usual insulating mica. This saves money and improves reliability through better cooling.

As mentioned earlier, the speaker output is taken from the midpoint of the power supply capacitors. This means that the audio output voltage is superimposed on top of the DC supply voltages, which must be kept in mind when checking these voltages. A stability filter, L1, R31, R32, and C5, eliminates the effects of reactive loads at frequencies way above the audio range where the amp might be unstable.

Muting Delay and Thermal Shutdown

A small independent power supply is derived through D8 and R33. This is a half-wave rectified signal brought from the secondary of the transformer. This supply is used to provide voltage to the pilot LED, mute RC time constant, and thermal shutdown circuits. When the amplifier is turned on, a 47 μ F 50V (E9) begins to charge until it reaches a point where it energizes the rest of the circuit to bias Q11 on. When Q11 is biased on, Q12 is no longer conducting. Q12 in its default state is biased on to where it is conducting current from the collector - emitter junction. This effectively cancels the 15 volt op-amp rails that appears at this junction. After approximately three seconds, when E9 charges up Q11, is turned on thereby turning off Q12. When Q12 is no longer in conduction, then the 15 volt rails are free to supply voltage to the op-amps on channel 1 and 2. A 4.7 μ F 160v capacitor (E8) serves as an immediate drain of voltage upon power up of the amplifier.

Excessive heat sink temperatures are sensed by a PTC resistor. This special part has a positive temperature coefficient which starts to increase rapidly above 80C. When the heat sink temperature reaches about 95C, the resistance is high enough to block power to Q11, and the signal is muted until the amplifier cools down. One drawback of this scheme is that it will not correct overheating due to run away idle current, so careful adjustment of crossover bias is essential.



Series One

1100 Input Jack Panel

Part Number	Description	Reference
CO-000005-BS	5 POSITION BARRIER STRIP	
CO-000008-OS	OCTAL SOCKET PC MOUNT	
CO-000010-FX	FEMALE PCB/PANEL MOUNT XLR	
CO-300112-PJ	JACK 1/4" PHONE DBLOPEN CKT	
HW-060040-PS	#6-32 X 4 PEM STUD	
HW-060120-SO	STANDOFF, 1/4" HEX AL 6-32X3	
HW-060150-SO	#6-32 X 29/32" STANDOFF	
PC-108052-DX	1100 JACKPLANE PCB	
SW-000008-DS	SWITCH, DIP, 8 POSITION	

1100 Chassis Assembly

Part Number	Description	Reference
CH-108203-GX	1100 FACEPLATE FABRICATION	
CH-110200-DX	1100 CHASSIS, FAB.	
CH-140210-BX	1400 KNOB FABRICATION	
CO-000011-00	CONN DUAL 5-WAY BIND RD/BLK R	
CO-000012-00	CONN DUAL 5-WAY BIND RD/BLK L	
CO-640551-PC	8 CONNECTION PLUG COVER	
CO-641148-AP	8 CONNECTION .156/C 18GA PLUG	
CO-641149-AP	8 CONNECTION .156"/C 20GA PLUG	
HW-000010-HW	5MM X 20MM DOUBLE FUSEHOLDER	
LB-000035-00	LABEL, UL AND CSA LISTING	
LB-000053-00	LBL, FRENCH, FUSE REPLACEMENT	
LB-108208-AX	LABEL, BRIDGING SWITCH, 1100	
LB-110202-BX	1100 FACEPLATE LABEL	
LB-300203-AX	LABEL, OCTAL SOCKET COVER	
MS-000007-RS	#7 RUBBER STOPPER (1 HOLE)	
MS-6.3250-FU	6.3A,250V FUSE , EXPORT	
NW-060400-HN	#6-32 X 1/4" HEX NUT	
NW-060410-ST	A-4 SPRING TOOTH LOCKWASHER	
NW-100007-TN	1/4"-20 X 3/4" PALLET NUT	
NW-114380-00	1 1/4 OD 7/16 ID X 1/16" WASHR	
NW-140623-LW	1/4" INTERNAL TOOTH LOCKWASHER	
NW-380801-IL	3/8" INTERNAL TOOTH LOCKWASHER	
PL-000000-AF	ADHESIVE FEET	
PL-000001-SR	HEYCO 6W-1 STRAIN RELIEF 16/3	
PL-000003-CP	AC CORD PROTECTOR	
PL-000034-PL	.187 TERMINAL INSULATORS	
PL-110500-AX	1100/1080 PCB ADH. INSULATOR	
PL-912140-SP	SPACER,ROUND,NYLON,#8,0.140"L	
SC-040041-PP	#4-40 X 1/4" P/P BLACK	
SC-060061-PP	#6-32 X 3/8" P/P BLACK	
SC-060081-PP	#6-32 X 1/2" P/P BLACK	
SC-061081-PP	#6 X 3/8" "B" P/P ZINC	
SC-081101-SP	#8-18 X 5/8", TYPE 1 P/P BLACK	
SC-140201-PP	1/4"-20X1 1/4" PP BLK OXIDE	
SW-000016-SW	SPST SNAP IN POWER SWITCH	
SW-0002.5-CB	SWITCH,THERMAL CIR. BRKR.,2.5A	
WC-001007-AX	QSC WIRE 1007, 2", BLACK	
WC-001025-TQ	QSC WIRE 1025, 4.25", PURPLE	

1100 Chassis Assembly (cont.)

Part Number	Description	Reference
WC-001026-TQ	QSC WIRE 1026, 4.25", WHITE	
WC-001029-TQ	QSC WIRE 1029, 4", BLACK	
WC-001031-BX	1031 AC CORD, 76", BLACK	
WC-001051-TQ	QSC WIRE 1051, PUR/WHT	
WC-001052-TQ	QSC WIRE 1052, BLK/WHT	
WC-003046-AX	110 WIRE ASSY (FUSE)	
WP-108002-CP	1100 PREPPED HEATSINK RIGHT	
WP-108003-CP	1100 PREPPED HEATSINK LEFT	
WP-108052-JP	1100 JACKPLANE	
WP-110051-TD	1100 MAIN PCB	
XF-001100-BX	XFMR P TOROIDAL 1100 117V	

1100 Main Board Assembly

Part Number	Description	Reference
CA-047100-BD	CAP CER 47PF 10% 100V, NPO	C3A,B
CA-210100-BP	CAP MYLAR .001UF 10% 100V	C1A,B,C10
CA-222100-BP	CAP MYLAR .0022UF 10% 100V	C4A,B, C9A,B
CA-333100-BP	CAP MYLAR .033UF 10% 100V	C6A,B
CA-368100-BP	CAP MYLAR .068UF 10% 100V	C2A,B, C5A,B, C7A,B
CA-368250-AS	CAP SURGE .068UF 20% 250VAC	C8
CA-547016-BN	CAP LYTIC RL 4.7UF 20% 16V NP	E1A,B
CA-610035-BE	CAP LYTIC RL 10UF 20% 35V	E4
CA-710035-BE	CAP LYTIC RL 100UF 20% 35V	E2A,B, E3A,B,E5
CA-847051-BE	CAP LYTIC RL 4700UF 20% 50V	E6A,B, E7A,B
CO-000008-IC	8 PIN IC SOCKET	REF:IC1A,B
CO-000060-00	8 PIN, .156"/C HEADER	CO7,CO8
CO-108112-PJ	.25" PHONE JACK RT ANGLE PC MT	CO-5,CO-6
IC-000021-00	IC LIN DUAL OP AMP 5532	IC1A,B
MS-000220-HS	TO-220 HEAT SINK AAVID #5943B	Q2A,B REF:Q1A,B,
PC-108051-FX	1100 MAIN AMP PCB	
PL-903125-SP	SPACER,ROUND,NYLON,0.125"L	2 PLACES, D3A,B, D4A,B REF:R17A,B
PL-905385-SP	SPACER,ROUND,NYLON,#6,0.385"L	LD2 REF:LD1A,B
PL-909235-SP	HOLDER,LED,90 DEGREE,NYLON	LD2 REF:LD1A,B
PT-110000-AT	RES VAR IT 100 20% 0.15W CARB	TR1A,B, TR3A,B
PT-250000-CR	RES VAR IT 5K 20% 0.2W	VR1A,B
PT-410000-AT	RES VAR IT 100K 20% 0.15W CARB	TR2A,B
QD-000018-QD	XISTOR NPN TO-220 200V 1A	Q1A,B
QD-000019-QD	XISTOR PNP TO-220 200V 1A	Q2A,B



1100 Main Board Assembly (cont.)

Part Number	Description	Reference
QD-000134-LG	LED GRN T-1 3/4	LD2
QD-000134-LR	LED RED T-1 3/4	LD1A,B
QD-0003.9-ZT	DIODE ZNR 3.9V TESTED	Z4A,B
QD-0004.7-ZT	DIODE ZNR 4.7V TESTED	Z3A,B
QD-004004-DX	DIODE RECT DO41 400V 1A	D5A,B, D6A,B
QD-004410-TX	XISTOR NPN TO-92 80V 0.25A	Q5
QD-004744-ZA	DIODE ZNR 15V 5% 1W 1N4744A	Z1A,B, Z2A,B
QD-004749-ZA	DIODE ZNR 24V 5% 1W 1N4749A	Z5
QD-004934-DX	DIODE RECT DO41 FAST 100V 1A	D1A,B, D2A,B, D3A,B, D4A,B
QD-050200-BX	DIODE BRIDGE RECT 200V 5A	B2A,B
QD-1.5200-BX	DIODE BRIDGE RECT 200V 1.5A	B1A,B,B3
RE-.47005-DM	RES MOFP 4.7 5% 1W	R15A,B, R16A,B
RE-.56005-EM	RES MOFP 5.6 5% 2W	R25A,B
RE-000050-NR	THERMISTOR NTC 50 OHM	R17A,B
RE-003305-DM	RES MOFP 33 5% 1W	R18A,B, R19A,B
RE-012005-EM	RES MOFP 120 5% 2W	R24A,B
RE-027005-EM	RES MOFP 270 5% 2W	R26A,B, R27A,B
RE-028001-BM	RES MF 280 1% 1/4W	R6A,B
RE-110005-BC	RES CF 1K 5% 1/4W	R11A,B, R12A,B, R13A,B, R14A,B
RE-113005-EM	RES MOFP 1.3K 5% 2W	R5A,B, R22A,B, R23A,B,R28
RE-139005-BC	RES CF 3.9K 5% 1/4W	R21
RE-162005-CC	RES CF 6.2K 5% 1/2W	R20
RE-210001-BM	RES MF 10.0K 1% 1/4W	R1A,B, R2A,B, R3A,B, R4A,B
RE-210002-CM	RES MF 10.0K 2% 1/2W	R10A,B
RE-247002-CM	RES MF 47.5K 1% 1/2W	R8A,B, R9A,B
RE-310005-BC	RES CF 100K 5% 1/4W	R7A,B
SW-000001-RY	RELAY, PCB, DPDT, ORIGINAL	K1
SW-000151-SW	SWITCH, SLIDE, SPDT	BRIDGE SW
WC-0.6022-JW	.6" JUMPER, WHITE, 22 GA, SLD	J1-J5
WC-1.5022-JW	1.5" JUMPER, WHITE, 22 GA, SLD	J11 J6,7,9,10,
WC-2.0024-FJ	15 CKT, 2"LONG FLEX JUMPER	W1
WC-2.5018-JW	2.5" JUMPER, WHT, 18 GA, SLD	J8,12

1100 Main Board Assembly (cont.)

Part Number	Description	Reference
XF-200010-RL	INDUCTOR 2UH W/10 OHM AXIAL	L1A,B
XF-270003-XF	INDUCTOR 27UH 3A AXIAL	F1A,B

Series One Input Jack Panel

Part Number	Description	Reference
CO-000005-BS	5 POSITION BARRIER STRIP	
CO-000008-OS	OCTAL SOCKET PC MOUNT	
CO-000010-FX	FEMALE PCB/PANEL MOUNT XLR	
CO-300112-PJ	JACK 1/4" PHONE DBLOPEN CKT PC	
CO-640385-AH	16 PIN .156/C RT ANGLE HEADER	
HW-060040-PS	#6-32 X 4 PEM STUD	
HW-060120-SO	STANDOFF, 1/4" HEX AL 6-32X3/4"	
HW-060150-SO	#6-32 X 29/32" STANDOFF	
PC-140045-FX	1200/1400/1700 JACKPLANE PCB	
PT-320300-CR	RES VAR IT 20K 20% 0.2W	
RE-147005-BC	RES CF 4.7K 5% 1/4W	
SW-000008-DS	SWITCH, DIP, 8 POSITION	

1200 Chassis Assembly

Part Number	Description	Reference
CH-140101-00	CHASSIS, SA/USA/SER.1 3 SPACE	
CH-140203-EX	1400 RACK EAR FABRICATION	
CH-140204-JX	1400 FACEPLATE	
CH-140210-BX	1400 KNOB FABRICATION	
CO-000011-00	CONN DUAL 5-WAY BIND RD/BLK R	
CO-000012-00	CONN DUAL 5-WAY BIND RD/BLK L	
LB-000035-00	LABEL, UL AND CSA LISTING	
LB-120202-DX	LABEL, 1200 INPUT JACKPLANE	
LB-120206-BX	1200 FACEPLATE LABEL, FAB.	
LB-120210-00	LABEL - OUTPUT 1200	
LB-300203-AX	LABEL, OCTAL SOCKET COVER	
NW-040422-SW	TOSHIBA SHOULDER WASHER	
NW-060400-HN	#6-32 X 1/4" HEX NUT	
NW-100600-KP	#10-32 KEPS NUT	
NW-380801-IL	3/8" INTERNAL TOOTH LOCKWASHER	
PL-000001-SR	HEYCO 6W-1 STRAIN RELIEF 16/3	
PL-000003-CP	AC CORD PROTECTOR	
SC-040061-PT	#4-40 X 3/8" P/T BLACK	
SC-060030-PU	#6-32 X 3/16 P/F UNDERCUT ZINC	
SC-060061-PP	#6-32 X 3/8" P/P BLACK	
SC-060081-PP	#6-32 X 1/2" P/P BLACK	
SC-061081-PP	#6 X 3/8" "B" P/P ZINC	
SC-081101-SP	#8-18 X 5/8", TYPE 1 P/P BLACK	
SC-100121-PS	#10-32 X 3/4" P/P SEMS BLACK	
SW-000016-SW	SPST SNAP IN POWER SWITCH	
WC-001005-AX	QSC WIRE 1005, 2.5", BLACK	
WC-001007-AX	QSC WIRE 1007, 2", BLACK	



Series One

1200 Chassis Assembly (cont.)

Part Number	Description	Reference
WC-003050-AX	PWR CORD 100/120VAC	
WP-120002-CP	1200 PREPPED CIRCUIT BREAKER	
WP-120044-TD	1200 MAIN DOM	
WP-140045-JP	SERIES 1 JCKPLN	
XF-001201-BX	XFMR P 1200 115/230V	

1200 Main Board Assembly

Part Number	Description	Reference
CA-047100-BD	CAP CER 47PF 10% 100V, NPO	C2AB
CA-110100-BM	CAP SM 100PF 5% 100V	C1ab,6ab
CA-222100-BP	CAP MYLAR .0022UF 10% 100V	C11ab
CA-222200-BP	CAP MYLAR .0022UF 10% 200V	C12ab
CA-233100-BP	CAP MYLAR .0033UF 10% 100V	C4ab,8ab, C9ab
CA-310100-BP	CAP MYLAR .01UF 10% 100V	C7ab
CA-368100-BP	CAP MYLAR .068UF 10% 100V	C3ab,5ab
CA-368250-AS	CAP SURGE .068UF 20% 250VAC	C10
CA-547016-BN	CAP LYTIC RL 4.7UF 20% 16V NP	E1ab
CA-547160-BE	CAP LYTIC RL 4.7UF 10% 160V	E8
CA-647050-BE	CAP LYTIC RL 47UF 20% 50V	E9
CA-710035-BE	CAP LYTIC RL 100UF 20% 35V	E2ab,3ab
CA-833080-BE	CAP LYTIC RL 3300UF 10% 80V	E4b,5a,7ab
CH-140208-LX	1200/1400/1700 HEATSINK, FAB.	
CO-000008-IC	8 PIN IC SOCKET	IC1ab
CO-350432-AP	.084" PIN 9 CONTACT PCB HEADER	P1
HW-000001-FC	FUSE CLIPS	F1ab
HW-060100-PS	STUD PEM 6-32 X 0.625"	
HW-060405-SP	SPACER RND AL .25"OD X 5/32"L	
HW-060600-SO	STANDOFF 1/4" HEX AL 6-32 M/F	
IC-000021-00	IC LIN DUAL OP AMP 5532	IC1A,B
LB-120209-AX	LABEL, UL. FUSE CAUTION	
MS-000048-HS	HEAT SINK, ISOL TO-220	REF:Q1A,B, REF:Q2A,B
MS-070125-FU	7A, 125V, FUSE	F1ab
NW-060500-KP	#6-32 KEPS NUT	
PC-140044-LX	PCB, MAIN BOARD, 1200/1400	
PL-000000-AF	ADHESIVE FEET	
PL-903125-SP	SPACER,ROUND,NYLON,0.125"L	D1A,B, D2A,B, L1A,B, R38A,B
PL-905156-SP	SPACER,ROUND,NYLON,#6,0.155"L	REF: LD3
PL-905325-SP	SPACER, ROUND,NYLON,#6,0.325"L	LD1ab,2
PL-909235-SP	HOLDER,LED,90 DEGREE,NYLON	LD1ab,2
PT-110000-AT	RES VAR IT 100 20% 0.15W CARB	TR3ab
PT-250000-AT	RES VAR IT 5K 20% 0.15W CARB	TR4ab,5ab
PT-422000-AT	RES VAR IT 220K 20% 0.5W CERM	TR2ab
QD-000004-TX	XISTOR NPN UNIWATT 60V 2A	Q12
QD-000018-QD	XISTOR NPN TO-220 200V 1A	Q1A,B

1200 Main Board Assembly (cont.)

Part Number	Description	Reference
QD-000019-QD	XISTOR PNP TO-220 200V 1A	Q2A,B
QD-000032-QD	XISTOR NPN TO-3 200V 16A	Q10B Q7A,8B,9A,
QD-000033-QD	XISTOR PNP TO-3 200V 16A	Q3A,4B,5A, Q6B
QD-000134-LG	LED GRN T-1 3/4	LD2
QD-000134-LR	LED RED T-1 3/4	LD1ab
QD-0003.9-ZT	DIODE ZNR 3.9V TESTED	Z3ab
QD-0004.7-ZT	DIODE ZNR 4.7V TESTED	Z4ab
QD-001340-LR	LED RED T-1 3/4 VOLTAGE REF	LD3
QD-004004-DX	DIODE RECT DO41 400V 1A	D10ab,11ab D4ab-7ab,8
QD-004744-ZA	DIODE ZNR 15V 5% 1W 1N4744A	Z1ab,2ab,5
QD-004934-DX	DIODE RECT DO41 FAST 100V 1A	D1ab,2ab
QD-008599-TX	XISTOR PNP TO-92 60V 0.5A	Q11
QD-1.5200-BX	DIODE BRIDGE RECT 200V 1.5A	B2ab
QD-400400-BX	DIODE BRIDGE RECT 400V 40A	B1ab
RE-02205-FW	RES WW 0.22 10% 3W	R23a,24b, R25a,26b, R27a,28b, R29a,30b
RE-56005-EM	RES MOFP 5.6 5% 2W	R31ab
RE-68005-DM	RES MOFP 6.8 5% 1W	R15ab,16ab
RE-000009-PT	RES PTC 90C 0.1K MAX COLD	PTC
RE-000050-NR	THERMISTOR NTC 50 OHM	R38ab

1400 Chassis Assembly

Part Number	Description	Reference
CH-140101-00	CHASSIS, SA/USA/SER.1 3 SPACE	
CH-140203-EX	1400 RACK EAR FABRICATION	
CH-140204-JX	1400 FACEPLATE	
CH-140210-BX	1400 KNOB FABRICATION	
CO-000011-00	CONN DUAL 5-WAY BIND RD/BLK R	
CO-000012-00	CONN DUAL 5-WAY BIND RD/BLK L	
LB-000035-00	LABEL, UL AND CSA LISTING	
LB-140211-LX	FACEPLATE LABEL	
LB-140212-FX	LABEL, 1400 INPUT JACKPLANE	
LB-140226-00	LABEL - OUTPUT 1400	
LB-300203-AX	LABEL, OCTAL SOCKET COVER	
MS-000069-00	FAN ASSY, 1400	
NW-040422-SW	TOSHIBA SHOULDER WASHER	
NW-060400-HN	#6-32 X 1/4" HEX NUT	
NW-380801-IL	3/8" INTERNAL TOOTH LOCKWASHER	
PL-000001-SR	HEYCO 6W-1 STRAIN RELIEF 16/3	
PL-000003-CP	AC CORD PROTECTOR	
SC-040061-PT	#4-40 X 3/8" P/T BLACK	
SC-060030-PU	#6-32 X 3/16 P/F UNDERCUT ZINC	
SC-060061-PP	#6-32 X 3/8" P/P BLACK	
SC-060081-PP	#6-32 X 1/2" P/P BLACK	



1400 Chassis Assembly

Part Number	Description	Reference
SC-061081-PP	#6 X 3/8" "B" P/P ZINC	
SC-081101-SP	#8-18 X 5/8", TYPE 1 P/P BLACK	
SC-100061-PS	#10-32 X 3/8" P/P SEMS BLACK	
SW-000016-SW	SPST SNAP IN POWER SWITCH	
WC-001004-CX	QSC AC CORD 1004, 72", BLACK	
WC-001005-AX	QSC WIRE 1005, 2.5", BLACK	
WC-001007-AX	QSC WIRE 1007, 2", BLACK	
WP-140003-CP	1400 PREPPED CIRCUIT BREAKER	
WP-140044-TD	1400 MAIN DOM	
WP-140045-JP	SERIES 1 JCKPLN	
XF-001401-BX	XFMR P 1400 115/230V	

1400 Main Board Assembly

Part Number	Description	Reference
CA-068100-BD	CAP CER 68PF 10% 100V	C2A,B
CA-110100-BM	CAP SM 100PF 5% 100V	C1ab,6ab
CA-222100-BP	CAP MYLAR .0022UF 10% 100V	C11ab
CA-222200-BP	CAP MYLAR .0022UF 10% 200V	C4ab,12ab
CA-233100-BP	CAP MYLAR .0033UF 10% 100V	C8ab,9ab
CA-310100-BP	CAP MYLAR .01UF 10% 100V	C7ab
CA-368100-BP	CAP MYLAR .068UF 10% 100V	C3ab,5ab
CA-368250-AS	CAP SURGE .068UF 20% 250VAC	C10
CA-547016-BN	CAP LYTIC RL 4.7UF 20% 16V NP	E1ab
CA-547160-BE	CAP LYTIC RL 4.7UF 10% 160V	E8
CA-647050-BE	CAP LYTIC RL 47UF 20% 50V	E9
CA-710035-BE	CAP LYTIC RL 100UF 20% 35V	E2ab,3ab
CA-822100-BE	CAP LYTIC RL 2200UF 10% 100V	E4ab,5ab, E6ab,7ab
CH-140208-LX	1200/1400/1700 HEATSINK, FAB.	
CO-000008-IC	8 PIN IC SOCKET	IC1ab
CO-350432-AP	.084" PIN 9 CONTACT PCB HEADER	P1
HW-000001-FC	FUSE CLIPS	F1ab
HW-060100-PS	STUD PEM 6-32 X 0.625"	
HW-060405-SP	SPACER RND AL .25"OD X 5/32"L	
HW-060600-SO	STANDOFF 1/4" HEX AL 6-32 M/F	
IC-000021-00	IC LIN DUAL OP AMP 5532	IC1A,B
LB-140225-AX	LABEL, UL. FUSE CAUTION	
MS-000048-HS	HEAT SINK, ISOL TO-220	REF:Q1A,B, REF:Q2A,B
MS-120250-FU	12A 250V, FUSE	F1ab
NW-060500-KP	#6-32 KEPS NUT	
PC-140044-LX	PCB, MAIN BOARD, 1200/1400	
PL-000000-AF	ADHESIVE FEET	
PL-903125-SP	SPACER,ROUND,NYLON,0.125"L	D1ab,2ab, L1ab,R38ab
PL-905156-SP	SPACER,ROUND,NYLON,#6,0.155"L	REF: LD3
PL-905325-SP	SPACER, ROUND,NYLON,#6,0.325"L	LD1ab,2
PL-909235-SP	HOLDER,LED,90 DEGREE,NYLON	LD1ab,2
PT-110000-AT	RES VAR IT 100 20% 0.15W CARB	TR3ab

1400 Main Board Assembly (cont.)

Part Number	Description	Reference
PT-250000-AT	RES VAR IT 5K 20% 0.15W CARB	TR4ab,5ab
PT-422000-AT	RES VAR IT 220K 20% 0.5W CERM	TR2ab
QD-000004-TX	XISTOR NPN UNIWATT 60V 2A	Q12
QD-000018-QD	XISTOR NPN TO-220 200V 1A	Q1A,B
QD-000019-QD	XISTOR PNP TO-220 200V 1A	Q2A,B
QD-000032-QD	XISTOR NPN TO-3 200V 16A	Q7AB-10AB
QD-000033-QD	XISTOR PNP TO-3 200V 16A	Q3AB-6AB
QD-000134-LG	LED GRN T-1 3/4	LD2
QD-000134-LR	LED RED T-1 3/4	LD1ab
QD-0003.9-ZT	DIODE ZNR 3.9V TESTED	Z3ab
QD-0004.7-ZT	DIODE ZNR 4.7V TESTED	Z4ab
QD-001340-LR	LED RED T-1 3/4 VOLTAGE REF	LD3
QD-004004-DX	DIODE RECT DO41 400V 1A	D11ab D4ab-7ab D8,10ab, Z1ab,2ab, Z5
QD-004744-ZA	DIODE ZNR 15V 5% 1W 1N4744A	Z1ab,2ab, Z5
QD-004934-DX	DIODE RECT DO41 FAST 100V 1A	D1ab,2ab
QD-008599-TX	XISTOR PNP TO-92 60V 0.5A	Q11
QD-1.5200-BX	DIODE BRIDGE RECT 200V 1.5A	B2ab
QD-400400-BX	DIODE BRIDGE RECT 400V 40A	B1ab
RE-.02205-FW	RES WW 0.22 10% 3W	R23ab-30ab
RE-.56005-EM	RES MOFP 5.6 5% 2W	R31ab
RE-.68005-DM	RES MOFP 6.8 5% 1W	R15ab,16ab
RE-000009-PT	RES PTC 90C 0.1K MAX COLD	PTC
RE-000050-NR	THERMISTOR NTC 50 OHM	R38ab
RE-000140-NR	THERMISTOR NTC 9A CUR LIM	R37
RE-001005-EM	RES MOFP 10 5% 2W	R32ab
RE-002205-DM	RES MOFP 22 5% 1W	R17ab,18ab
RE-015001-BM	RES MF 150 1% 1/4W	R14ab,36ab
RE-016501-BM	RES MF 165 1% 1/4W	R5ab
RE-025010-NW	RES WW 250 10% 15W	R42
RE-045010-HW	RES WW 450 10% 5W	R22ab
RE-075001-BM	RES MF 750 1% 1/4W	R10ab
RE-110005-BC	RES CF 1K 5% 1/4W	R12ab,13ab
RE-130005-EM	RES MOFP 3K 5% 2W	R20ab,21ab
RE-147005-BC	RES CF 4.7K 5% 1/4W	R11ab
RE-162005-CC	RES CF 6.2K 5% 1/2W	R19
RE-168005-BC	RES CF 6.8K 5% 1/4W	R34,41
RE-210001-BM	RES MF 10.0K 1% 1/4W	R1ab-4ab
RE-210002-CM	RES MF 10.0K 2% 1/2W	R6ab
RE-210005-EM	RESISTOR,MET FLM,10K 5% 2W	R39
RE-247005-CC	RES CF 47K 5% 1/2W	R9ab
RE-247005-DM	RES MOFP 47K 5% 1W	R35
RE-310005-BC	RES CF 100K 5% 1/4W	R7AB,8AB, R40
RE-318005-BC	RES CF 180K 5% 1/4W	R33
SC-061041-SP	#6-32X1/4" "A" P/P W/SCRAPING	PTC,55C
SC-062050-PP	#6 X 5/16" "B" P/P ZINC	
SW-000055-TS	55C THERMAL CUT-IN SWITCH	55C



Series One

1400 Main Board Assembly (cont.)

Part Number	Description	Reference
SW-000151-SW	SWITCH, SLIDE, SPDT	NORM BRDGE
WC-0.6022-JW	.6" JUMPER, WHITE, 22 GA, SLD	J2,8,9,19
WC-0.9022-JW	.9" JUMPER, WHITE, 22 GA, SLD	J1,3,4,15, J21,22,28, J29,31
WC-001102-SQ	INSUL. SLEEVE QSC 1102,.6",CLR	PTC
WC-001103-SQ	INSUL SLEEVE 1103,.875",CLEAR	REF: 55C
WC-1.2518-JW	1.25" JUMPER, WHITE 18 GA, SLD	J23
WC-1.5022-JW	1.5" JUMPER, WHITE, 22 GA, SLD	J11,12,16, J17,18,20 J5,6,7,10,
WC-2.5018-JW	2.5" JUMPER, WHT, 18 GA, SLD	J13,14,24, J25-27
XF-200016-CR	INDUCTOR 2UH 18AWG VERT MNT	L1ab

1700 Chassis Assembly

Part Number	Description	Reference
CH-140210-BX	1400 KNOB FABRICATION	
CH-170101-00	CHASSIS, SA/1700	
CH-170203-AX	1700 RACK EAR FABRICATION	
CH-170204-EX	1700 FACEPLATE FABRICATION	
CH-170205-AX	1700 FAN SHROUD	
CO-000011-00	CONN DUAL 5-WAY BIND RD/BLK R	
CO-000012-00	CONN DUAL 5-WAY BIND RD/BLK L	
LB-000035-00	LABEL, UL AND CSA LISTING	
LB-100000-CT	CHASSIS CONTROL TAG	
LB-140102-00	LABEL OUTPUT SLC	
LB-170210-BX	LABEL, INPUT, 1700	
LB-170212-CX	1700 UPPER FACEPLATE LABEL,FAB	
LB-170213-BX	1700 LOWER FACEPLATE LABEL,FAB	
LB-300203-AX	LABEL, OCTAL SOCKET COVER	
MS-000069-00	FAN ASSY, 1400	
NW-060400-HN	#6-32 X 1/4" HEX NUT	
NW-380801-IL	3/8" INTERNAL TOOTH LOCKWASHER	
PL-000003-CP	AC CORD PROTECTOR	
PL-000008-SR	HEYCO SR-7P-2 STR. RELIEF 14/3	
SC-040061-PT	#4-40 X 3/8" P/T BLACK	
SC-060042-PP	#6-32 X 1/4" P/P BLACK,SEMS,IT	
SC-060061-PP	#6-32 X 3/8" P/P BLACK	
SC-060081-PP	#6-32 X 1/2" P/P BLACK	
SC-061041-SP	#6-32X1/4" "A" P/P W/SCRAPING	
SC-081101-SP	#8-18 X 5/8", TYPE 1 P/P BLACK	
SC-100061-PS	#10-32 X 3/8" P/P SEMS BLACK	
SW-380015-SB	SWITCH,CIRCUIT BREAKER, 15A	
WC-001038-BX	1038 AC CORD, 88", BLACK	
WC-003062-00	AC SWITCH WIRE, RED. 6.12"	
WC-003090-00	WIRE ASSY, 10"LG, (RED/YEL)	
WC-003091-00	WIRE ASSY, 7"LG, (WHT/BLU)	
WP-140045-JP	SERIES 1 JCKPLN	

1700 Chassis Assembly (cont.)

Part Number	Description	Reference
WP-170053-TD	1700 CHNL 1 DOM	
WP-170054-TD	1700 CHNL 2 DOM	
XF-001700-BX	XFMR P 1700 120/230V	

1700 Ch.1 Main Board Assembly

Part Number	Description	Reference
CA-027100-BM	CAP SM 27PF 10% 100V	C4
CA-110100-BM	CAP SM 100PF 5% 100V	C1,2
CA-147100-BD	CAP CER 470PF 10% 100V	C5
CA-215200-BP	CAP MYLAR .0015UF 10% 200V	C7
CA-222100-BP	CAP MYLAR .0022UF 10% 100V	C8
CA-310100-BP	CAP MYLAR .01UF 10% 100V	C6
CA-333100-BP	CAP MYLAR .033UF 10% 100V	C9
CA-410250-AS	CAP SURGE .1UF 20% 250VAC	C10
CA-412100-CP	CAP MYLAR .12UF 5% 100V	C3
CA-610035-BE	CAP LYTIC RL 10UF 20% 35V	E4
CA-647010-BN	CAP LYTIC RL 47UF 10% 10V NP	E1
CA-647050-BE	CAP LYTIC RL 47UF 20% 50V	E5
CA-722010-BN	CAP LYTIC RL 220UF 20% 10V NP	E6
CA-722025-BE	CAP LYTIC RL 220UF 20% 25V	E2,3
CA-822100-BE	CAP LYTIC RL 2200UF 10% 100V	E7-14
CH-140208-LX	1200/1400/1700 HEATSINK, FAB.	
CO-000008-IC	8 PIN IC SOCKET	REF: IC1
CO-350432-AP	.084" PIN 9 CONTACT PCB HEADER	CO2
CO-641119-AH	8 PIN .156"/C HEADER	CO1
HW-000001-FC	FUSE CLIPS	REF: F1,2
HW-060100-PS	STUD PEM 6-32 X 0.625"	P
HW-060405-SP	SPACER RND AL .25"OD X 5/32"L	P
HW-060600-SO	STANDOFF 1/4" HEX AL 6-32 M/F	S
IC-000021-00	IC LIN DUAL OP AMP 5532	IC1
MS-000044-FT	FOAM ADHESIVE TAPE 1/8X 1/2 X1	PCB
MS-001220-HS	TO-220 HEATSINK AAVID 5939B	REF: Q1,2
MS-150250-FU	15A, 250V, FUSE	F1,2
NW-060010-SL	#6 SPLIT TOOTH LOCKWASHER	REF: Q1,2
NW-060500-KP	#6-32 KEPS NUT	
PC-170053-CX	OBS-1700 UPR MAIN PCB CH. 1	
PL-000000-AF	ADHESIVE FEET	PCB
PL-903125-SP	SPACER,ROUND,NYLON,0.125"L	R54
		REF: D5,6,
PL-905100-SP	SPACER,ROUND,NYLON,#6,0.100"L	REF: L1
PL-905156-SP	SPACER,ROUND,NYLON,#6,0.155"L	REF: LD3
PL-905200-SP	SPACER,ROUND,NYLON,#6,0.200"L	REF: LD1,2
PL-909235-SP	HOLDER,LED,90 DEGREE,NYLON	REF: LD1,2
PT-110000-AT	RES VAR IT 100 20% 0.15W CARB	TR1,2
PT-220000-AT	RES VAR IT 2K 20% 0.15W CARB	TR3
QD-000004-TX	XISTOR NPN UNIWATT 60V 2A	Q21
QD-000005-QD	XISTOR NPN TO-220 250V 1.5A	Q1
QD-000006-QD	XISTOR PNP TO-220 250V 1.5A	Q2
QD-000024-QD	DIODE ZNR 6.2V 5% TESTED	Z5

1700 Ch.1 Main Board Assembly (cont.)

Part Number	Description	Reference
QD-000032-QD	XISTOR NPN TO-3 200V 16A	Q11-Q18
QD-000033-QD	XISTOR PNP TO-3 200V 16A	Q3-Q10
QD-000134-LR	LED RED T-1 3/4	LD2
QD-000134-LX	LED RED/GRN T-1 3/4	LD1
QD-0003.9-ZT	DIODE ZNR 3.9V TESTED	Z4
QD-0004.7-ZT	DIODE ZNR 4.7V TESTED	Z1
QD-001340-LR	LED RED T-1 3/4 VOLTAGE REF	LD3
QD-004004-DX	DIODE RECT DO41 400V 1A	D1,2,D7-13
QD-004744-ZA	DIODE ZNR 15V 5% 1W 1N4744A	Z2,3
QD-004753-ZT	DIODE ZNR 36V 5% 1W 1N4753A	Z6
QD-004934-DX	DIODE RECT DO41 FAST 100V 1A	D5,6
QD-005402-DX	DIODE RECT DO27 200V 3A	D3,4
QD-008599-TX	XISTOR PNP TO-92 60V 0.5A	Q19,20
QD-1.5200-BX	DIODE BRIDGE RECT 200V 1.5A	B1,2
QD-400400-BX	DIODE BRIDGE RECT 400V 40A	B3
RE-.04705-FW	RES WW 0.47 10% 3W	R33-48
RE-.56005-EM	RES MOFP 5.6 5% 2W	R12,13,26
RE-000009-PT	RES PTC 90C 0.1K MAX COLD	PTC
RE-000050-NR	THERMISTOR NTC 50 OHM	R54
RE-001005-EM	RES MOFP 10 5% 2W	R27,28
RE-002205-DM	RES MOFP 22 5% 1W	R16,17
RE-015005-BC	RES CF 150 5% 1/4W	R25
RE-025010-NW	RES WW 250 10% 15W	R50
RE-033201-BM	RES MF 332 1% 1/4W	R7
RE-045010-HW	RES WW 450 10% 5W	R31
RE-068010-HW	RES WW 680 10% 5W	R49
RE-110005-BC	RES CF 1K 5% 1/4W	R5,14,15
RE-115005-BC	RES CF 1.5K 5% 1/4W	R24
RE-135005-HW	RES WW 3.5K 10% 5W	R52,53
RE-147005-BC	RES CF 4.7K 5% 1/4W	R6
RE-175005-EM	RES MOFP 7.5K 5% 2W	R29
RE-210001-BM	RES MF 10.0K 1% 1/4W	R1-4
RE-210005-EM	RESISTOR,MET FLM,10K 5% 2W	R30
RE-221001-CM	RES MF 21.0K 1% 1/2W	R9
RE-247005-CC	RES CF 47K 5% 1/2W	R21
RE-275001-BM	RES MF 75.0K 1% 1/4W	R8
RE-310005-BC	RES CF 100K 5% 1/4W	R22,23
RE-333005-BC	RES CF 330K 5% 1/4W	R19,20
SC-060060-PP	#6-32 X 3/8" P/P ZINC	REF: Q1,2
SC-061041-SP	#6-32X1/4" "A" P/P W/SCRAPING	IN & PTC REF:CUT-IN
SC-062050-PP	#6 X 5/16" "B" P/P ZINC	REF:Q3-Q18
SW-000013-RY	RELAY, SPDT, 15A, 24VDC	K1
SW-000055-TS	55C THERMAL CUT-IN SWITCH	CUT-IN
WC-0.5018-JW	.5" JUMPER, WHT., 18 GA, SOLID	J5
WC-0.6022-JW	.6" JUMPER, WHITE, 22 GA, SLD	J4
WC-001102-SQ	INSUL. SLEEVE QSC 1102,.6",CLR	REF: PTC
WC-001103-SQ	INSUL SLEEVE 1103,.875",CLEAR	REF:CUT-IN
WC-1.2518-JW	1.25" JUMPER, WHITE 18 GA, SLD	J2,3
WC-2.5018-JW	2.5" JUMPER, WHT, 18 GA, SLD	J1

1700 Ch.2 Main Board Assembly

Part Number	Description	Reference
CA-027100-BM	CAP SM 27PF 10% 100V	C4
CA-110100-BM	CAP SM 100PF 5% 100V	C1,2
CA-147100-BD	CAP CER 470PF 10% 100V	C5
CA-215200-BP	CAP MYLAR .0015UF 10% 200V	C7
CA-222100-BP	CAP MYLAR .0022UF 10% 100V	C8
CA-310100-BP	CAP MYLAR .01UF 10% 100V	C6
CA-333100-BP	CAP MYLAR .033UF 10% 100V	C9
CA-368250-AS	CAP SURGE .068UF 20% 250VAC	C11
CA-410250-AS	CAP SURGE .1UF 20% 250VAC	C10
CA-412100-CP	CAP MYLAR .12UF 5% 100V	C3
CA-610035-BE	CAP LYTIC RL 10UF 20% 35V	E4
CA-647010-BN	CAP LYTIC RL 47UF 10% 10V NP	E1
CA-647050-BE	CAP LYTIC RL 47UF 20% 50V	E5
CA-722010-BN	CAP LYTIC RL 220UF 20% 10V NP	E6
CA-722025-BE	CAP LYTIC RL 220UF 20% 25V	E2,3
CA-822100-BE	CAP LYTIC RL 2200UF 10% 100V	E7-14
CH-140208-LX	1200/1400/1700 HEATSINK, FAB.	
CO-000008-IC	8 PIN IC SOCKET	REF: IC1
CO-350432-AP	.084" PIN 9 CONTACT PCB HEADER	CO2
CO-641119-AH	8 PIN .156"/C HEADER	CO1
HW-000001-FC	FUSE CLIPS	REF: F1,2
HW-060100-PS	STUD PEM 6-32 X 0.625"	P
HW-060405-SP	SPACER RND AL .25"OD X 5/32"L	P
HW-060600-SO	STANDOFF 1/4" HEX AL 6-32 M/F	S
IC-000021-00	IC LIN DUAL OP AMP 5532	IC1
MS-000044-FT	FOAM ADHESIVE TAPE 1/8X 1/2 X1	PCB
MS-001220-HS	TO-220 HEATSINK AAVID 5939B	REF: Q1,2
MS-150250-FU	15A, 250V, FUSE	F1,2
NW-060010-SL	#6 SPLIT TOOTH LOCKWASHER	Q1,2
NW-060500-KP	#6-32 KEPS NUT	
PC-170054-CX	OBS-1700 LWR MAIN PCB CH.2	
PL-000000-AF	ADHESIVE FEET	PCB
PL-903125-SP	SPACER,ROUND,NYLON,0.125"L	R54
PL-905100-SP	SPACER,ROUND,NYLON,#6,0.100"L	REF: D5,6, REFI L1
PL-905156-SP	SPACER,ROUND,NYLON,#6,0.155"L	REF: LD3
PL-905200-SP	SPACER,ROUND,NYLON,#6,0.200"L	REF: LD1,2
PL-909235-SP	HOLDER,LED,90 DEGREE,NYLON	REF: LD1,2
PT-110000-AT	RES VAR IT 100 20% 0.15W CARB	TR1,2
PT-220000-AT	RES VAR IT 2K 20% 0.15W CARB	TR3
QD-000004-TX	XISTOR NPN UNIWATT 60V 2A	Q21
QD-000005-QD	XISTOR NPN TO-220 250V 1.5A	Q1
QD-000006-QD	XISTOR PNP TO-220 250V 1.5A	Q2
QD-000024-QD	DIODE ZNR 6.2V 5% TESTED	Z5
QD-000032-QD	XISTOR NPN TO-3 200V 16A	Q11-Q18
QD-000033-QD	XISTOR PNP TO-3 200V 16A	Q3-Q10
QD-000134-LR	LED RED T-1 3/4	LD2
QD-000134-LX	LED RED/GRN T-1 3/4	LD1
QD-0003.9-ZT	DIODE ZNR 3.9V TESTED	Z4
QD-0004.7-ZT	DIODE ZNR 4.7V TESTED	Z1



Series One

1700 Ch.2 Main Board Assembly (cont.)

Part Number	Description	Reference
QD-001340-LR	LED RED T-1 3/4 VOLTAGE REF	LD3
QD-004004-DX	DIODE RECT DO41 400V 1A	D1,2,D7-13
QD-004744-ZA	DIODE ZNR 15V 5% 1W 1N4744A	Z2,3
QD-004753-ZT	DIODE ZNR 36V 5% 1W 1N4753A	Z6
QD-004934-DX	DIODE RECT DO41 FAST 100V 1A	D5,6
QD-005402-DX	DIODE RECT DO27 200V 3A	D3,4
QD-008599-TX	XISTOR PNP TO-92 60V 0.5A	Q19,20
QD-1.5200-BX	DIODE BRIDGE RECT 200V 1.5A	B1,2
QD-400400-BX	DIODE BRIDGE RECT 400V 40A	B3
RE-.04705-FW	RES WW 0.47 10% 3W	R33-48
RE-.56005-EM	RES MOFP 5.6 5% 2W	R12,13,26
RE-000009-PT	RES PTC 90C 0.1K MAX COLD	PTC
RE-000050-NR	THERMISTOR NTC 50 OHM	R54
RE-000100-NR	THERMISTOR NTC 20A CUR LIM	1,5
RE-001005-EM	RES MOFP 10 5% 2W	R27,28
RE-002205-DM	RES MOFP 22 5% 1W	R16,17
RE-015005-BC	RES CF 150 5% 1/4W	R25
RE-033201-BM	RES MF 332 1% 1/4W	R7
RE-045010-HW	RES WW 450 10% 5W	R31
RE-068010-HW	RES WW 680 10% 5W	R49
RE-110005-BC	RES CF 1K 5% 1/4W	R5,14,15
RE-115005-BC	RES CF 1.5K 5% 1/4W	R24
RE-135005-HW	RES WW 3.5K 10% 5W	R52,53
RE-147005-BC	RES CF 4.7K 5% 1/4W	R6
RE-175005-EM	RES MOFP 7.5K 5% 2W	R29
RE-210001-BM	RES MF 10.0K 1% 1/4W	R1-4
RE-210005-EM	RESISTOR,MET FLM,10K 5% 2W	R30
RE-216501-CM	RES MF 16.5K 1% 1/2W	R51
RE-221001-CM	RES MF 21.0K 1% 1/2W	R9
RE-247005-CC	RES CF 47K 5% 1/2W	R21
RE-275001-BM	RES MF 75.0K 1% 1/4W	R8
RE-310005-BC	RES CF 100K 5% 1/4W	R22,23
RE-333005-BC	RES CF 330K 5% 1/4W	R19,20
SC-060060-PP	#6-32 X 3/8" P/P ZINC	REF: Q1,2
SC-061041-SP	#6-32X1/4" "A" P/P W/SCRAPING	& PTC REF:CUT-IN
SC-062050-PP	#6 X 5/16" "B" P/P ZINC	REF:Q3-Q18
SW-000013-RY	RELAY, SPDT, 15A, 24VDC	K1
SW-000055-TS	55C THERMAL CUT-IN SWITCH	CUT-IN
SW-000151-SW	SWITCH, SLIDE, SPDT	BR,SW
WC-0.5018-JW	.5" JUMPER, WHT., 18 GA, SOLID	J5
WC-0.6022-JW	.6" JUMPER, WHITE, 22 GA, SLD	J4
WC-001102-SQ	INSUL. SLEEVE QSC 1102,.6",CLR	REF: PTC
WC-001103-SQ	INSUL SLEEVE 1103,.875",CLEAR	REF:CUT-IN
WC-1.2518-JW	1.25" JUMPER, WHITE 18 GA, SLD	J2,3
WC-2.5018-JW	2.5" JUMPER, WHT, 18 GA, SLD	J1
XF-200014-CR	INDUCTOR 2UH 14AWG VERT MNT	L1

Semiconductors

MPS8598
MPS8599
PNP

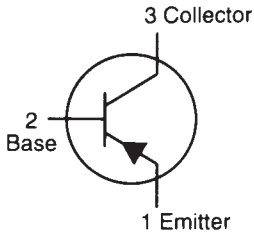

2N4409
2N4410
NPN

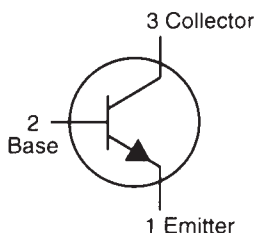

SMALL SIGNAL
TRANSISTORS



DRIVER TRANSISTORS

2SA1306 PNP
2SC3298 NPN

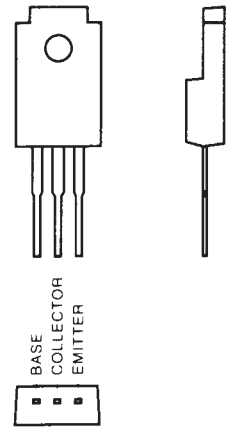

NE5532AN OP AMP

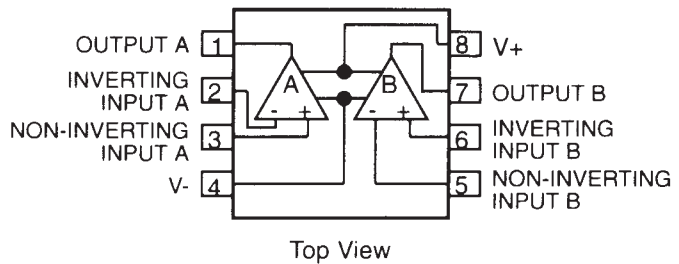

1100 CHASSIS ASSEMBLY

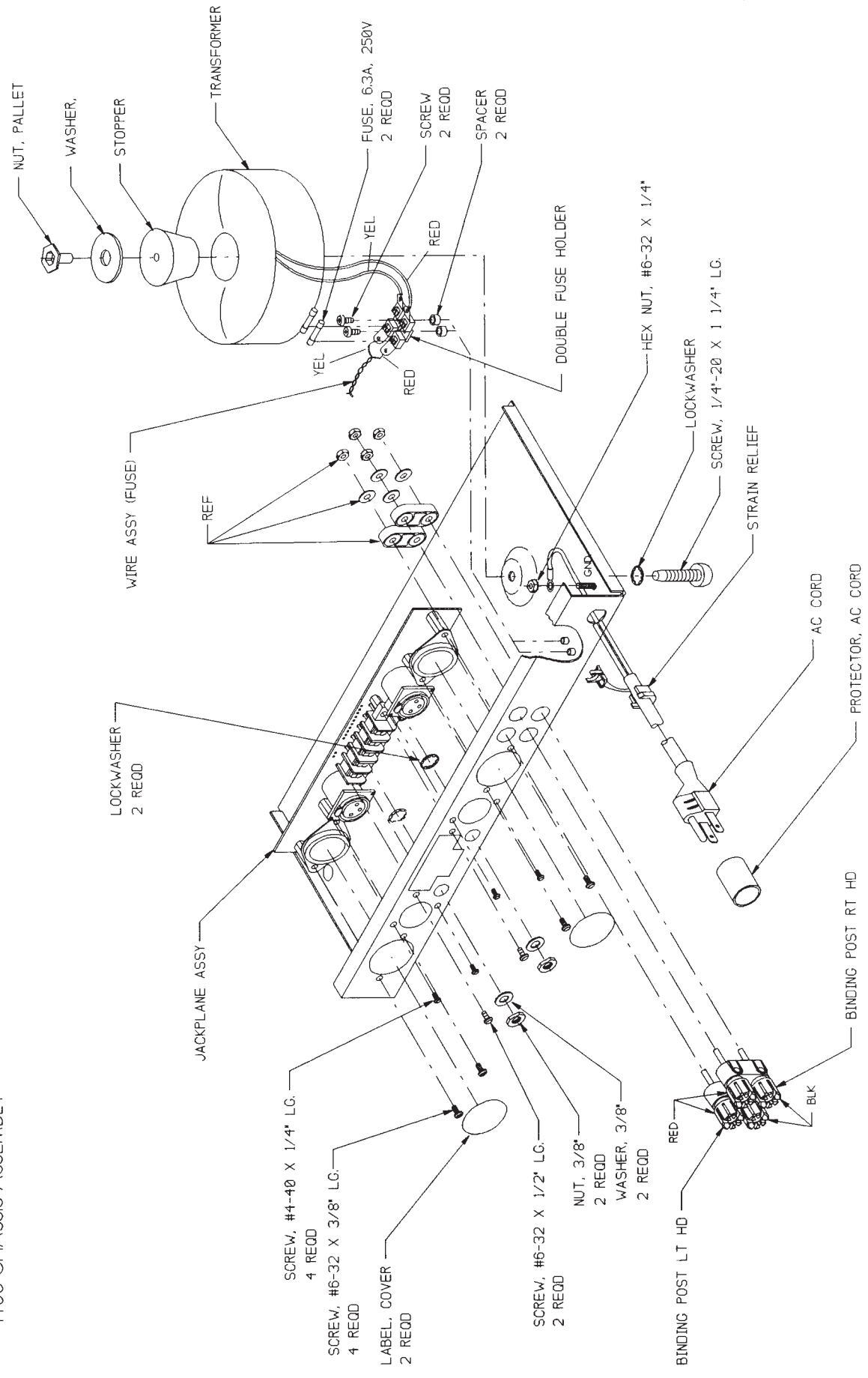



1200 / 1400 CHASSIS ASSEMBLY

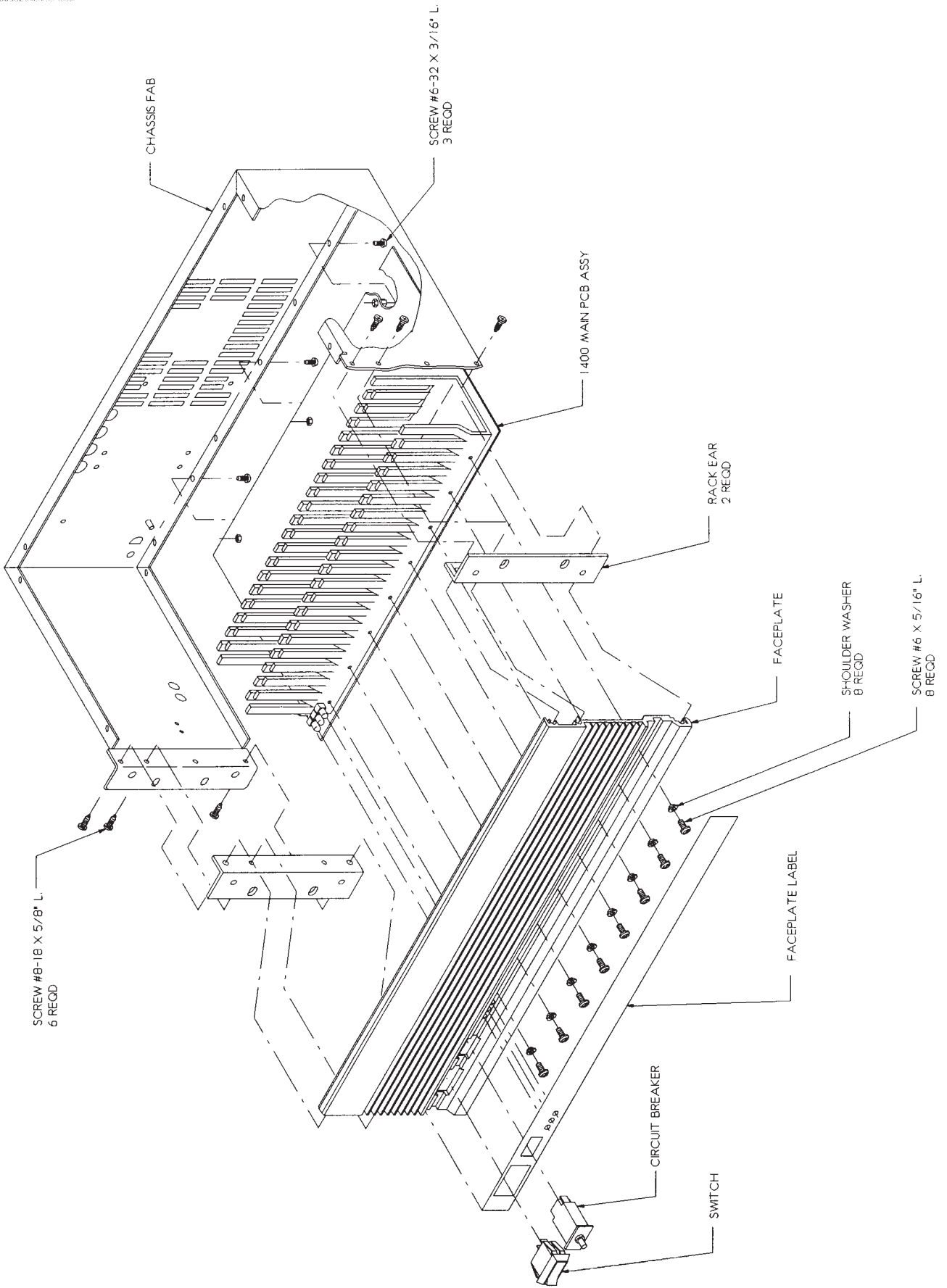

1200 / 1400 CHASSIS ASSEMBLY

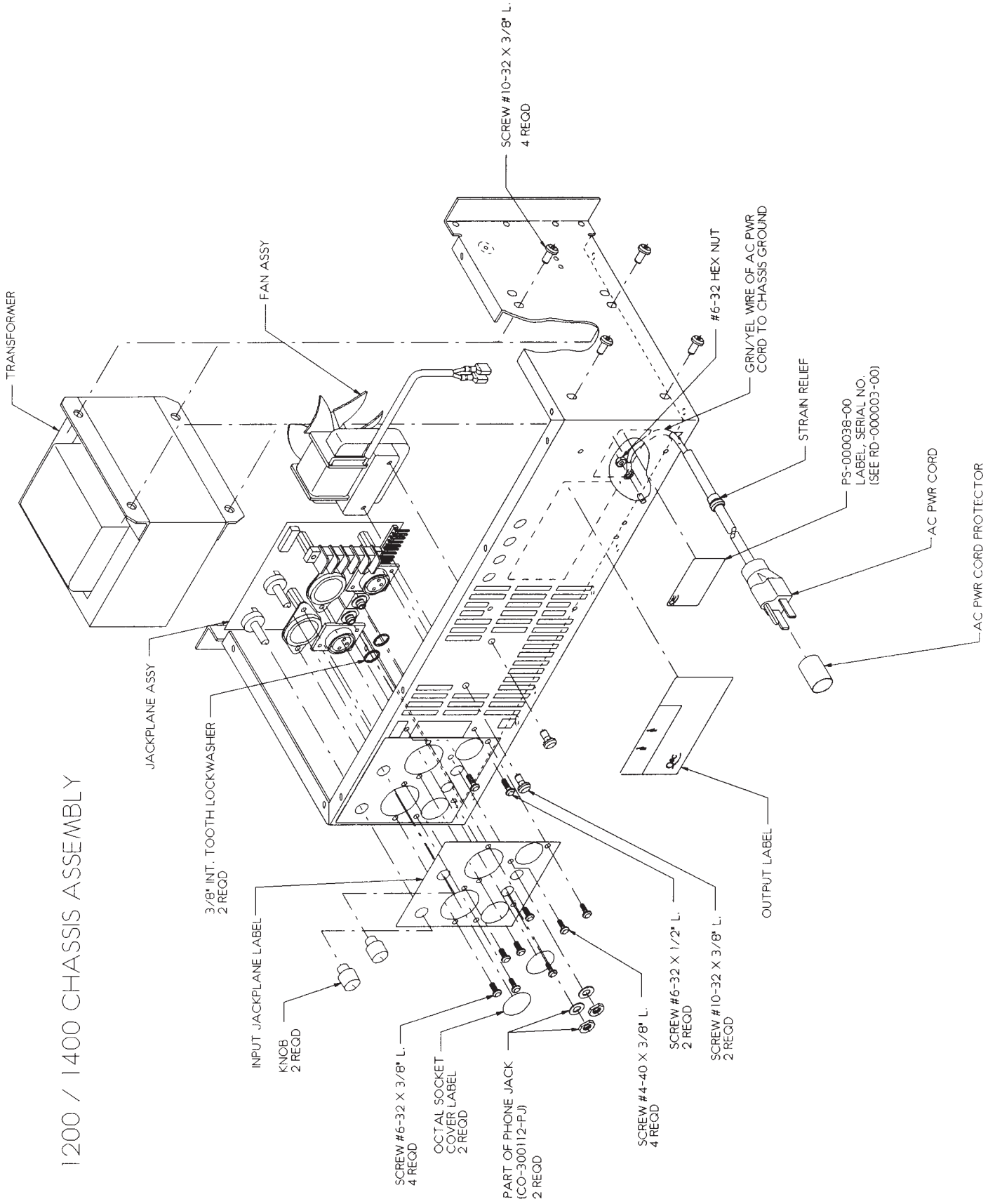



1200 / 1400 CHASSIS ASSEMBLY

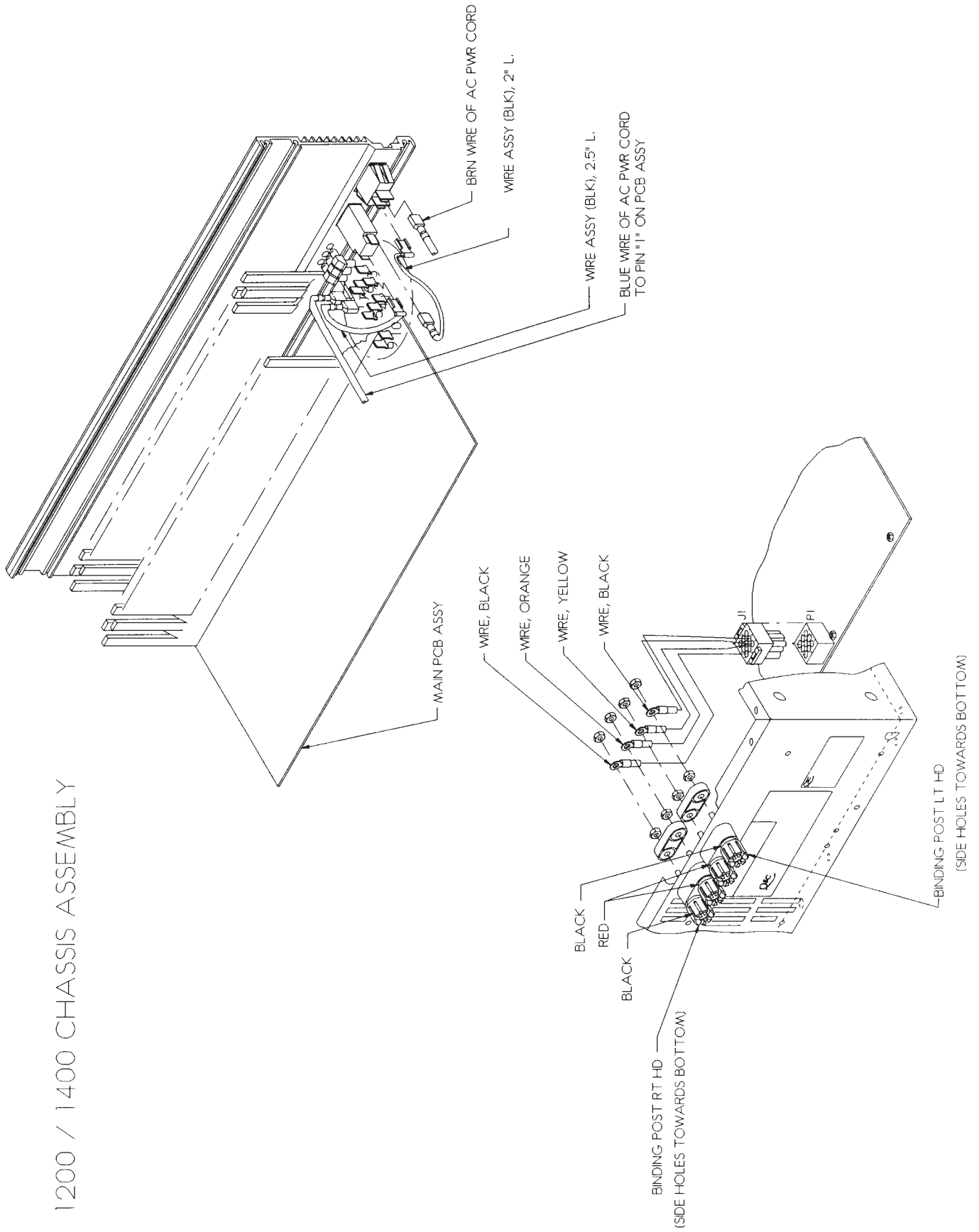

1700 CHASSIS ASSEMBLY

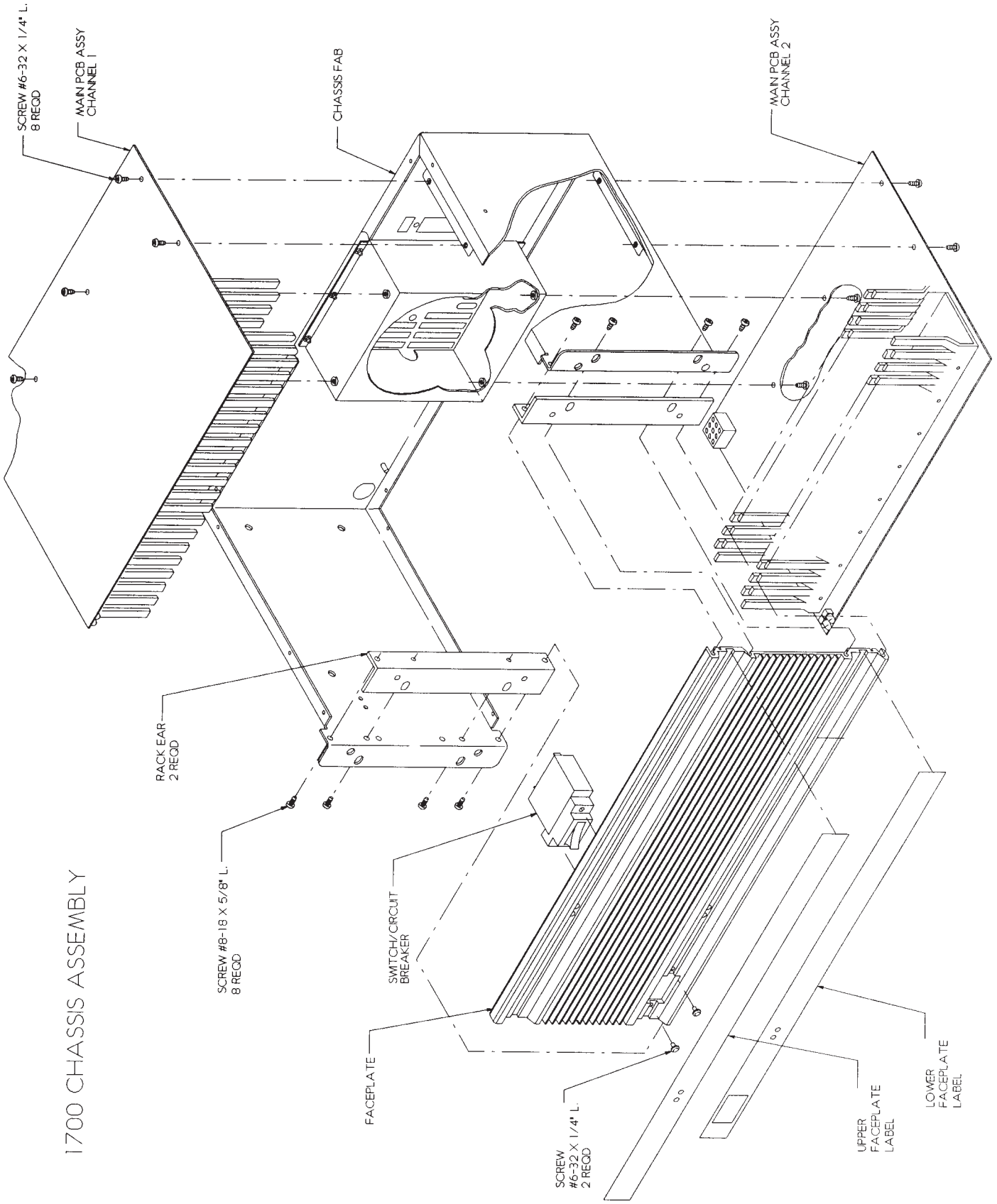

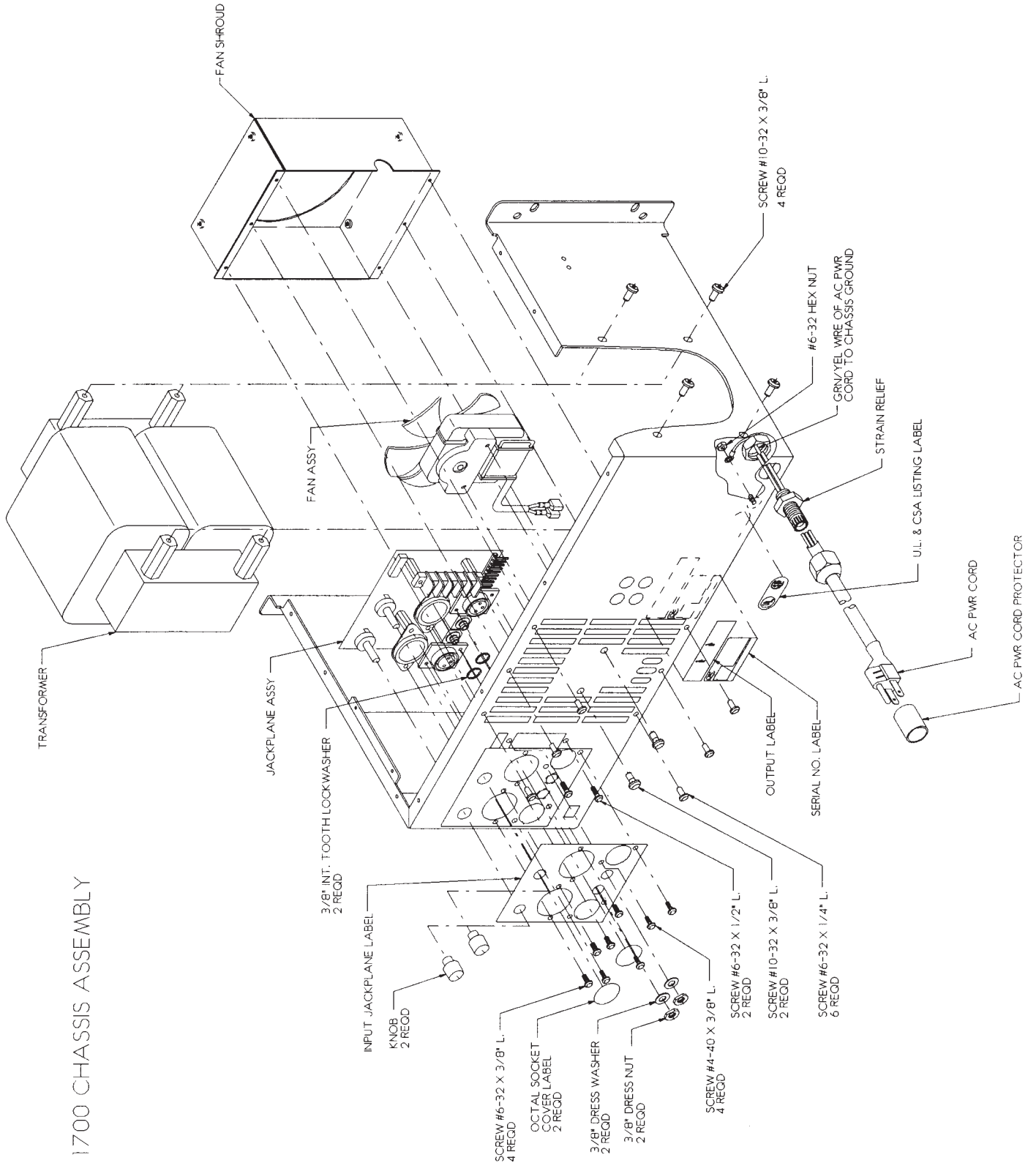

1700 CHASSIS ASSEMBLY

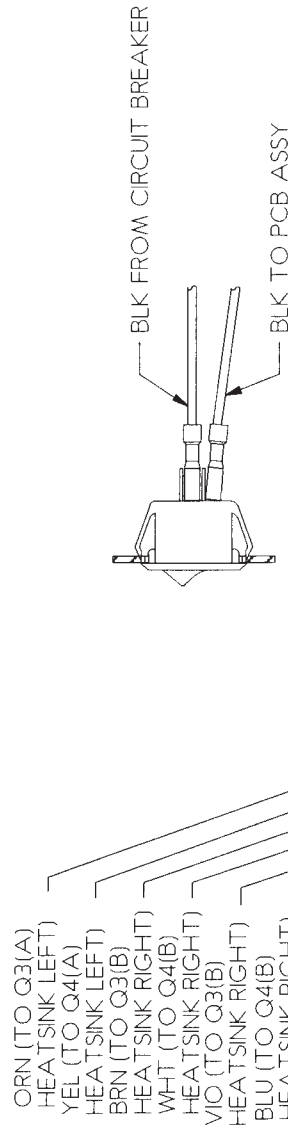
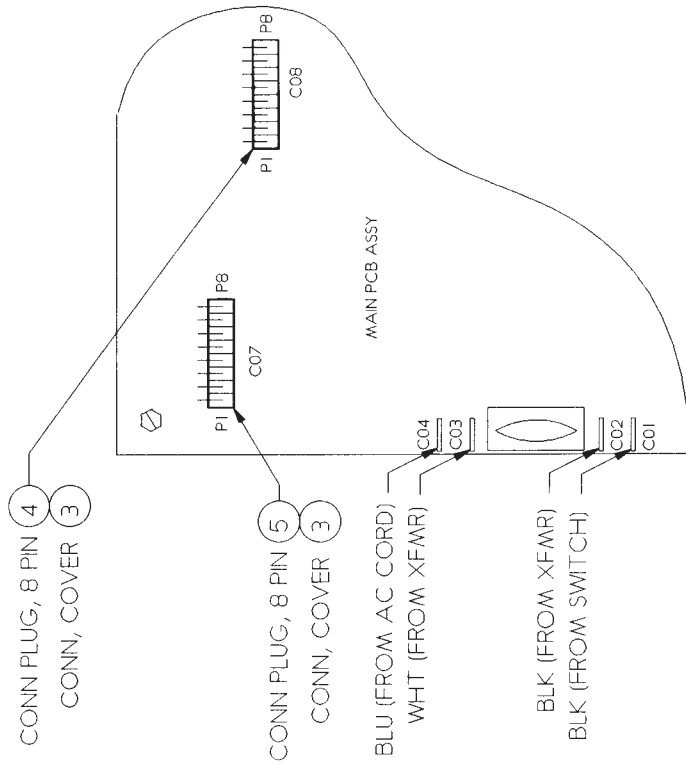

1100 WIRING DIAGRAM

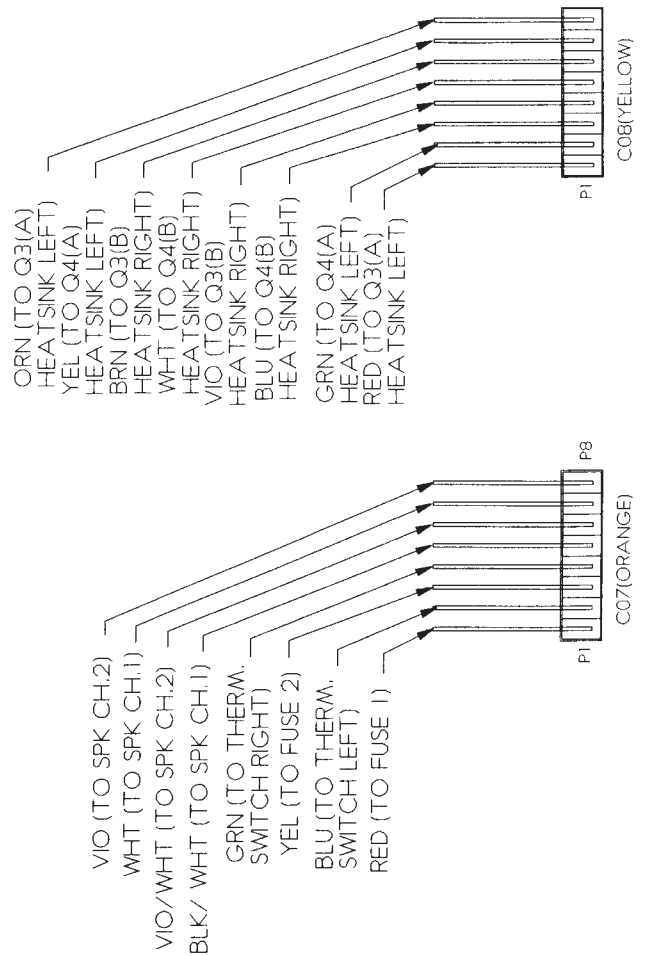

100 VOLT

WP-120044-TD

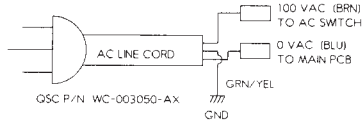
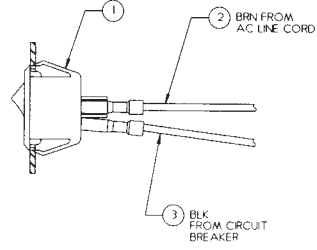
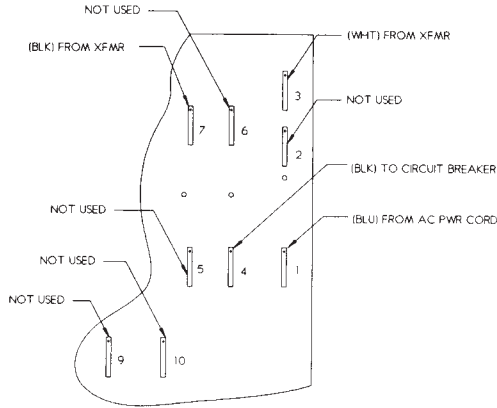

100 VOLT WIRING PCB & AC CORD

120 VOLT

WP-120044-TD

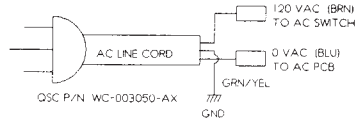
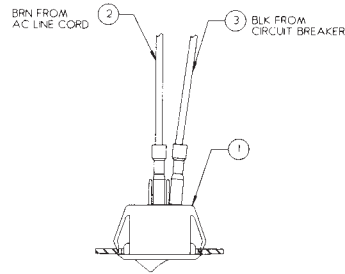
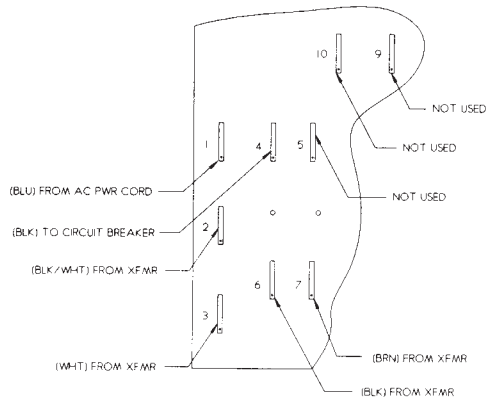

120 VOLT WIRING AC PCB & AC CORD

230 VOLT

WP-120044-TE

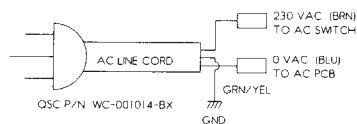
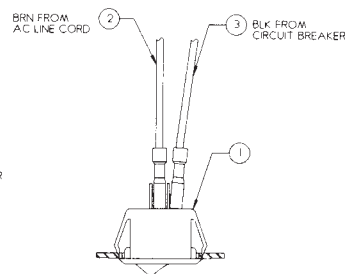
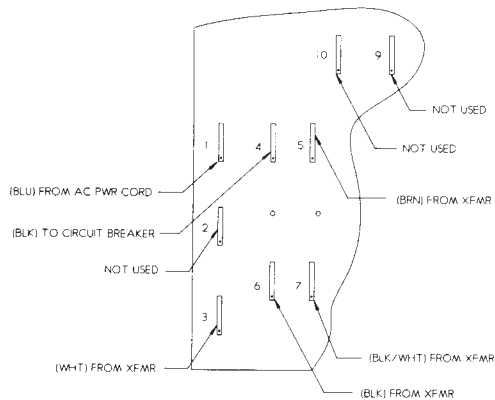

230 VOLT WIRING AC PCB & AC CORD

100 VOLT

WP-140044-TJ

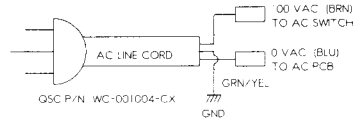
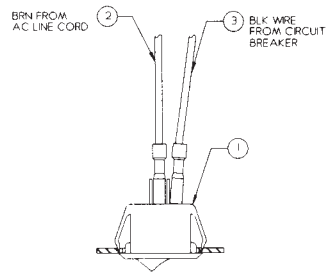
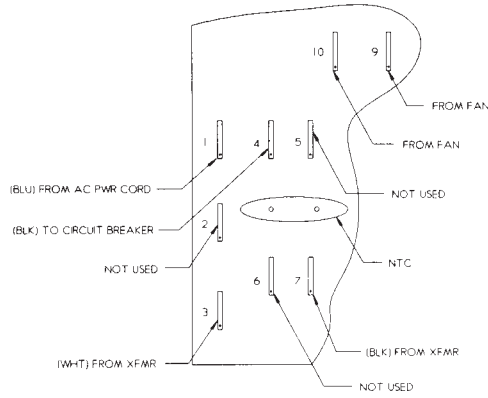

100 VOLT WIRING
AC PCB & AC CORD

120 VOLT

WP-140044-TD

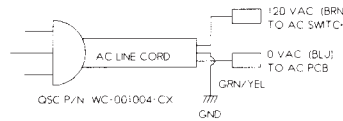
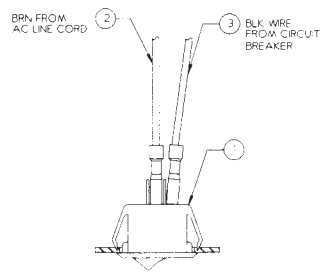
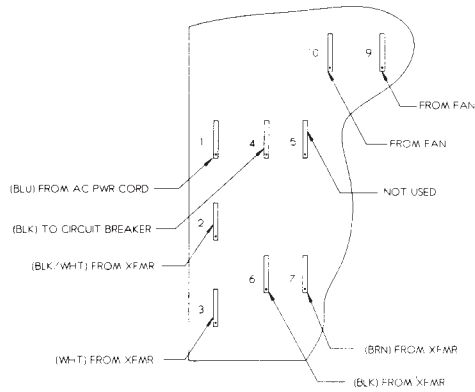

120 VOLT WIRING
AC PCB & AC CORD

230 VOLT

WP-140044-TE

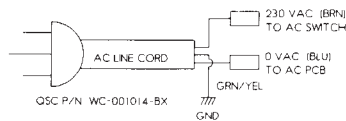
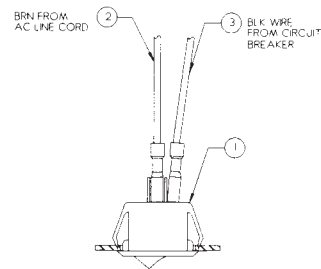
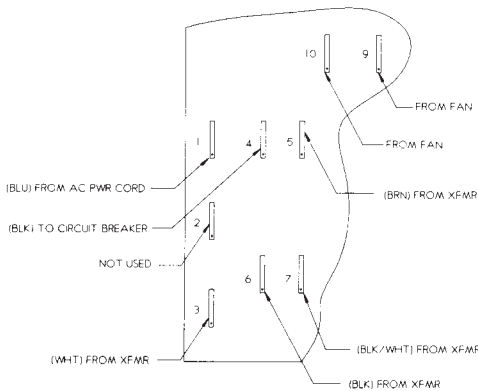

230 VOLT WIRING
AC PCB & AC CORD

100 VOLT

WP-170054-TJ

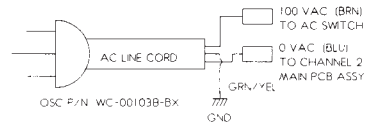
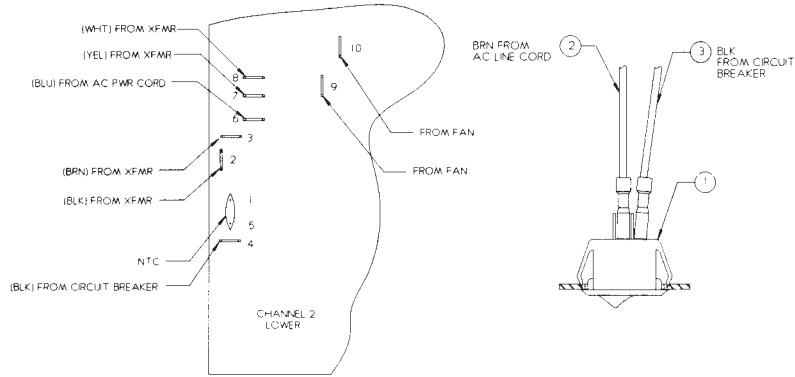

100 VOLT WIRING PCB & AC CORD

120 VOLT

WP-170054-TD

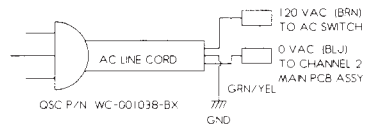
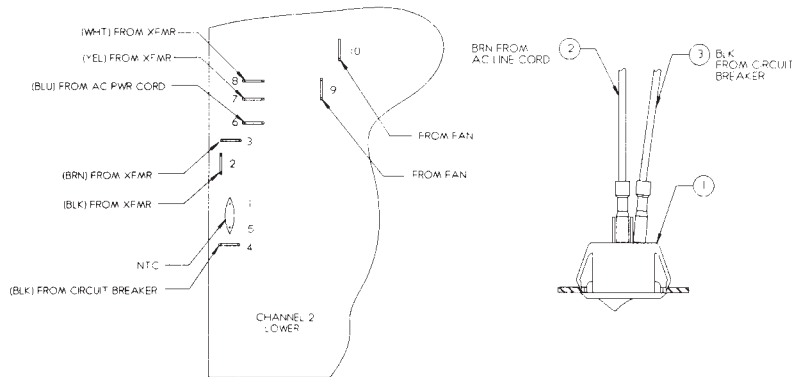

120 VOLT WIRING PCB & AC CORD

230 VOLT

WP-170054-TE

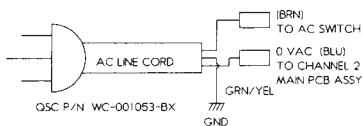
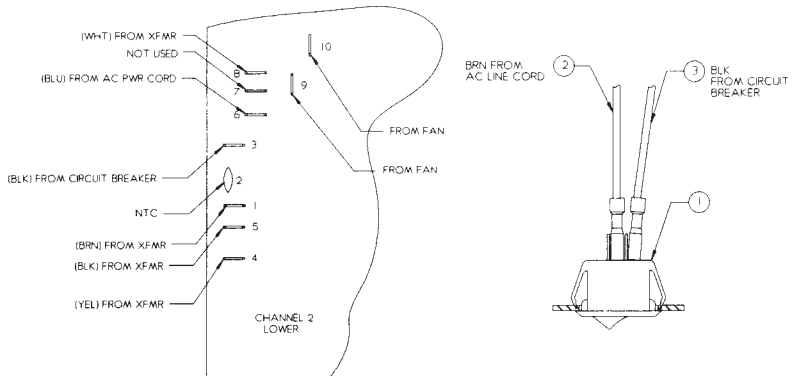

230 VOLT WIRING PCB & AC CORD

1100 Schematic

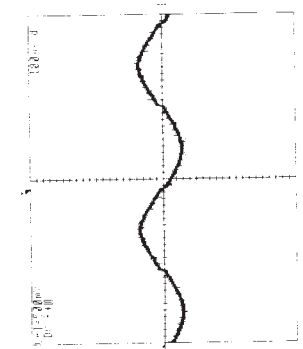
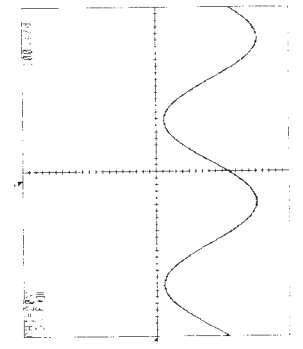
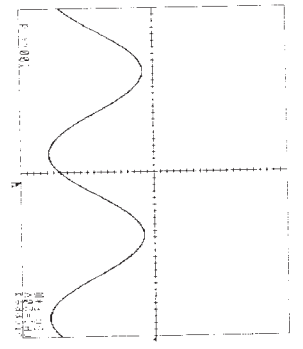
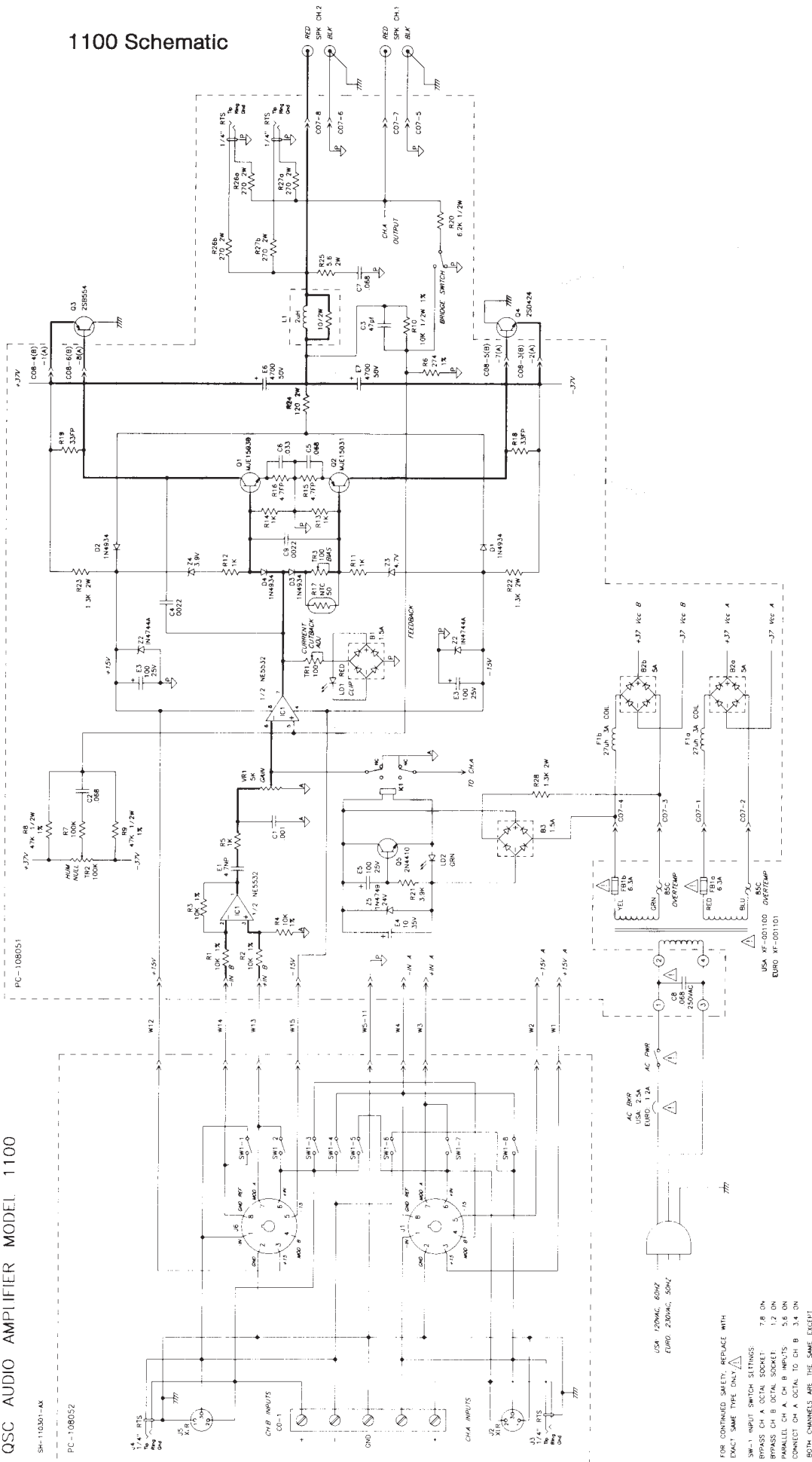

- 1. FOR CONTINUED SAFETY, REPLACE WITH EXACT SAME TYPE ONLY.
- 2. SW-1 INPUT SWITCH SETTINGS:
 - BYPASS CH A OCTAL SOCKET 7.8 OH
 - BYPASS CH B OCTAL SOCKET 1.2 OH
 - PARALLEL CH A, CH B INPUTS 5.6 OH
 - CORRECT CH A OCTAL TO CH B 3.4 OH
- 3. BOTH CHANNELS ARE THE SAME EXCEPT BRIDGE SWITCH (CHANNEL B SHOWN).
- 4. USE QSC REPLACEMENT TRANSISTORS ONLY.
- 5. TFP = FLAME PROOF RESISTOR FOR CONTINUED SAFETY. REPLACE WITH SAME TYPE ONLY.
- 6. ALL CAPACITORS ARE IN μF UNLESS NOTED.
- 7. ALL RESISTORS ARE 1% UNLESS NOTED.

NOTES: UNLESS OTHERWISE SPECIFIED.

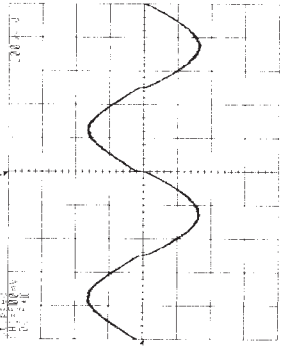
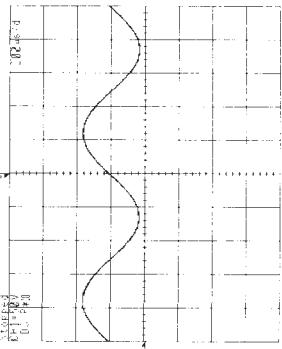
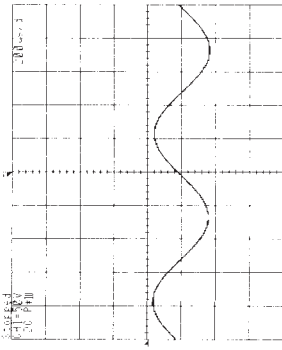

THIS DOCUMENT CONTAINS PROPRIETARY INFORMATION AND IS THE PROPERTY OF SENCOR RADIO PRODUCTS. IT IS NOT TO BE DISCLOSED, REPRODUCED OR USED IN ANY MANNER WITHOUT THE WRITTEN CONSENT FROM SENCOR RADIO PRODUCTS.

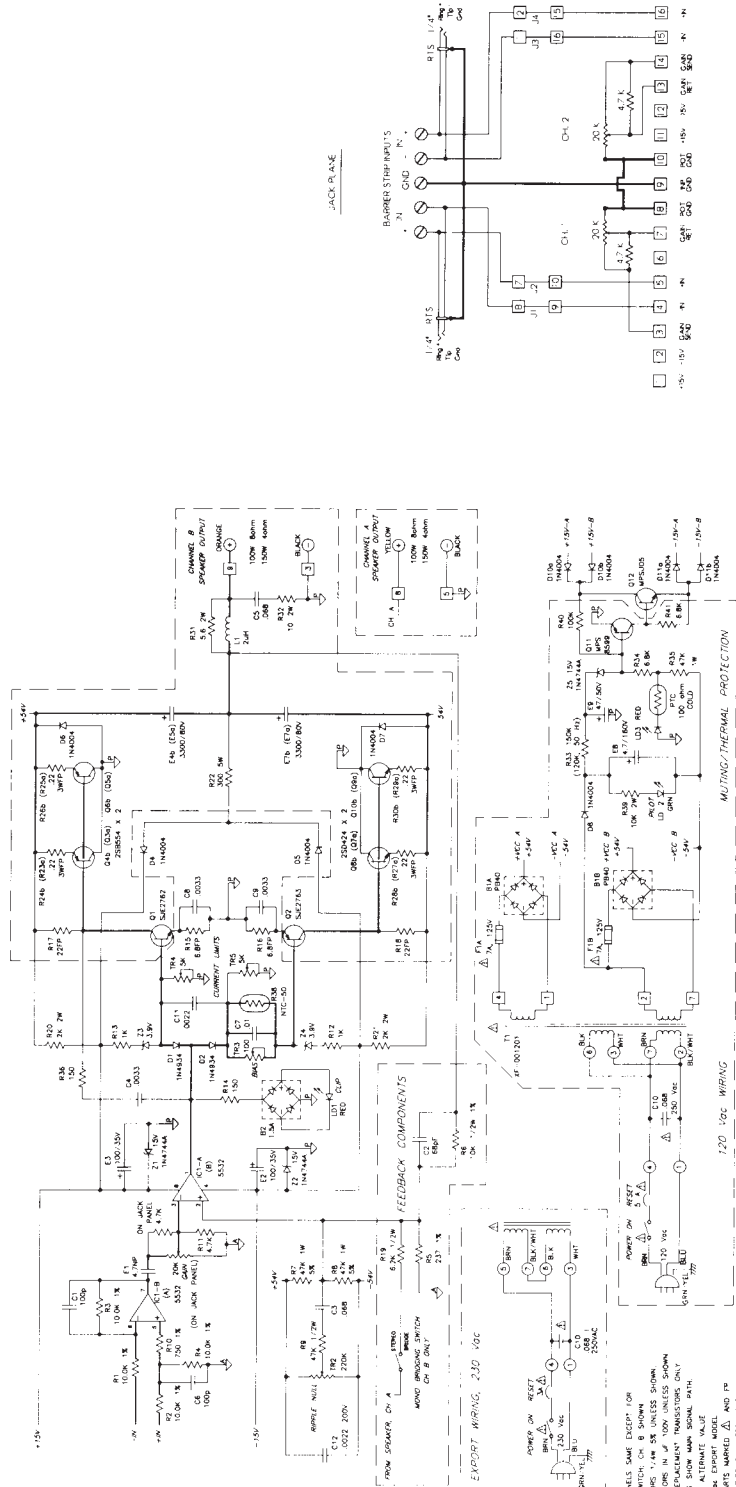

- NOTES
1. BOTH CHANNELS SAME EXCEPT FOR BRIDGING SWITCH ON B SHOWN
 2. ALL RESISTORS 1% UNLESS SHOWN OTHERWISE
 3. USE 5% REGULATORY TRANSISTORS ONLY
 4. HEAVY LINES SHOW MAIN SIGNAL PATH
 5. R33 SHOWS ALTERNATE VALUE
 6. REPLACE PARTS MARKED Δ AND ∇ WITH SAME TYPE ONLY FOR CONTINUED SAFETY
 7. ALL RESISTORS MARKED TP ARE OF FLAMPROOF TYPE
 8. ALL PARTS ARE TO BE USED IN PARALLEL
 9. CHANNEL 1P POINTS 1,2,3 BECOME 7,8,5 ON CHANNEL 2 AND 1P POINTS 7,8,5 BECOME 1,2,3 ON CHANNEL 1A

LAST USED	NOT USED
R9	C12
C1	C11
C2	R1
R3	R4
R5	R6
R7	R8
R9	R10
R11	R12
R13	R14
R15	R16
R17	R18
R19	R20
R21	R22
R23	R24
R25	R26
R27	R28
R29	R30
R31	R32
R33	R34
R35	R36
R37	R38
R39	R40
R41	R42
R43	R44
R45	R46
R47	R48
R49	R50
R51	R52
R53	R54
R55	R56
R57	R58
R59	R60
R61	R62
R63	R64
R65	R66
R67	R68
R69	R70
R71	R72
R73	R74
R75	R76
R77	R78
R79	R80
R81	R82
R83	R84
R85	R86
R87	R88
R89	R90
R91	R92
R93	R94
R95	R96
R97	R98
R99	R100
R101	R102
R103	R104
R105	R106
R107	R108
R109	R110
R111	R112
R113	R114
R115	R116
R117	R118
R119	R120
R121	R122
R123	R124
R125	R126
R127	R128
R129	R130
R131	R132
R133	R134
R135	R136
R137	R138
R139	R140
R141	R142
R143	R144
R145	R146
R147	R148
R149	R150
R151	R152
R153	R154
R155	R156
R157	R158
R159	R160
R161	R162
R163	R164
R165	R166
R167	R168
R169	R170
R171	R172
R173	R174
R175	R176
R177	R178
R179	R180
R181	R182
R183	R184
R185	R186
R187	R188
R189	R190
R191	R192
R193	R194
R195	R196
R197	R198
R199	R200

THIS DOCUMENT CONTAINS PROPRIETARY INFORMATION. THE DESIGN AND CONSTRUCTION OF OSC AUDIO PRODUCTS THAT THEY NOT BE DISCLOSED, REPRODUCED OR USED WITHOUT EXPRESS WRITTEN CONSENT FROM OSC AUDIO PRODUCTS

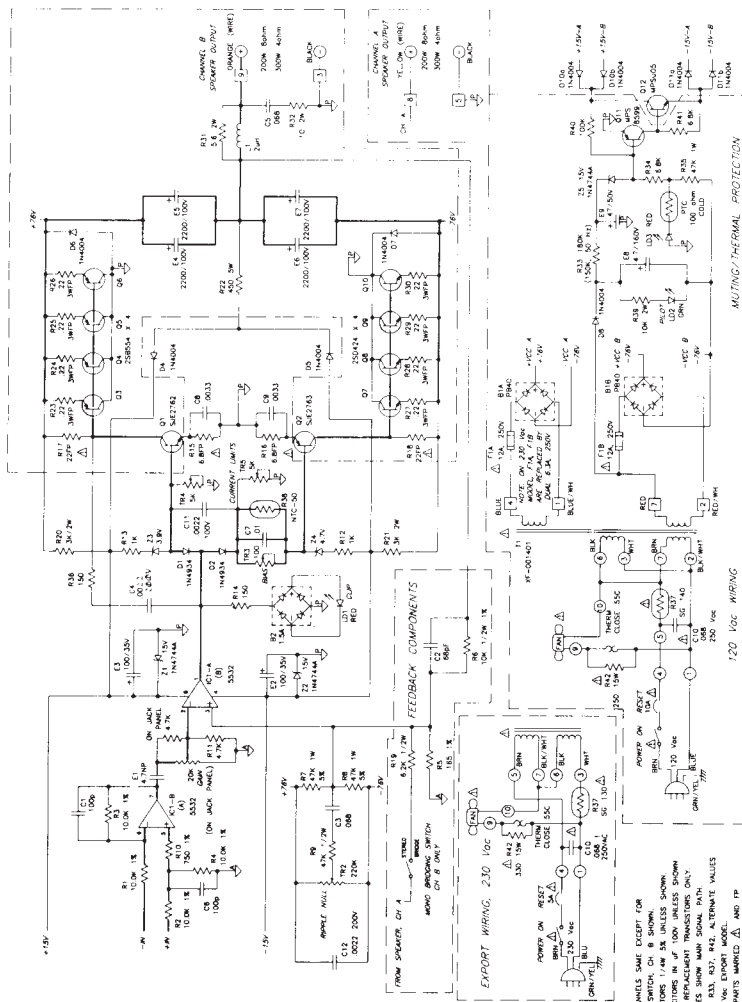
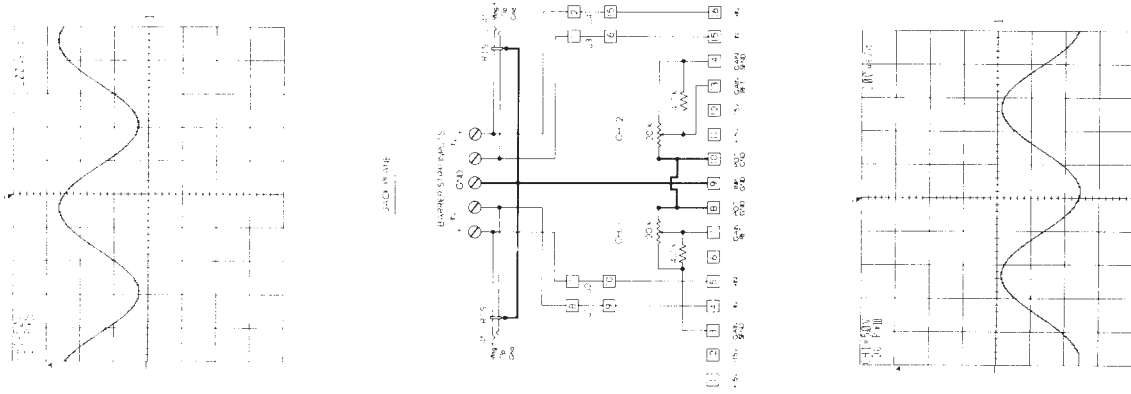

- NOTES
1. ALL COMPONENTS SAME EXCEPT FOR SWITCHING SWITCH, CH B SHOWN.
 2. ALL RESISTORS 1/4W 5% UNLESS SHOWN.
 3. ALL CAPACITORS IN μ F UNLESS SHOWN.
 4. ALL CAPACITORS IN nF UNLESS SHOWN.
 5. HEAVY LINES SHOW MAIN SIGNAL PATH ONLY.
 6. F1a, F1b, R33, R37, R42, A, TERMINAL VALUES.
 7. FOR 230 VAC EXPORT MODEL.
 8. WITH SAME PCB AND CASE FOR IMPROVED SAFETY.
 9. ALL RESISTORS MARKED 'TP' ARE OF FLAMERPROOF CONSTRUCTION AND MINIMUM OF 1/2 WATT.
 10. CHANNEL A AND B SHOWN IN PARENTHESES.
 11. C11-A AND C11-B PINNED TO 1, 2, 3, 4, 5, 6, 7, 8, 9, 10, 11, 12, 13, 14, 15, 16, 17, 18, 19, 20, 21, 22, 23, 24, 25, 26, 27, 28, 29, 30, 31, 32, 33, 34, 35, 36, 37, 38, 39, 40, 41, 42, 43, 44, 45, 46, 47, 48, 49, 50, 51, 52, 53, 54, 55, 56, 57, 58, 59, 60, 61, 62, 63, 64, 65, 66, 67, 68, 69, 70, 71, 72, 73, 74, 75, 76, 77, 78, 79, 80, 81, 82, 83, 84, 85, 86, 87, 88, 89, 90, 91, 92, 93, 94, 95, 96, 97, 98, 99, 100, 101, 102, 103, 104, 105, 106, 107, 108, 109, 110, 111, 112, 113, 114, 115, 116, 117, 118, 119, 120, 121, 122, 123, 124, 125, 126, 127, 128, 129, 130, 131, 132, 133, 134, 135, 136, 137, 138, 139, 140, 141, 142, 143, 144, 145, 146, 147, 148, 149, 150, 151, 152, 153, 154, 155, 156, 157, 158, 159, 160, 161, 162, 163, 164, 165, 166, 167, 168, 169, 170, 171, 172, 173, 174, 175, 176, 177, 178, 179, 180, 181, 182, 183, 184, 185, 186, 187, 188, 189, 190, 191, 192, 193, 194, 195, 196, 197, 198, 199, 200, 201, 202, 203, 204, 205, 206, 207, 208, 209, 210, 211, 212, 213, 214, 215, 216, 217, 218, 219, 220, 221, 222, 223, 224, 225, 226, 227, 228, 229, 230, 231, 232, 233, 234, 235, 236, 237, 238, 239, 240, 241, 242, 243, 244, 245, 246, 247, 248, 249, 250, 251, 252, 253, 254, 255, 256, 257, 258, 259, 260, 261, 262, 263, 264, 265, 266, 267, 268, 269, 270, 271, 272, 273, 274, 275, 276, 277, 278, 279, 280, 281, 282, 283, 284, 285, 286, 287, 288, 289, 290, 291, 292, 293, 294, 295, 296, 297, 298, 299, 300, 301, 302, 303, 304, 305, 306, 307, 308, 309, 310, 311, 312, 313, 314, 315, 316, 317, 318, 319, 320, 321, 322, 323, 324, 325, 326, 327, 328, 329, 330, 331, 332, 333, 334, 335, 336, 337, 338, 339, 340, 341, 342, 343, 344, 345, 346, 347, 348, 349, 350, 351, 352, 353, 354, 355, 356, 357, 358, 359, 360, 361, 362, 363, 364, 365, 366, 367, 368, 369, 370, 371, 372, 373, 374, 375, 376, 377, 378, 379, 380, 381, 382, 383, 384, 385, 386, 387, 388, 389, 390, 391, 392, 393, 394, 395, 396, 397, 398, 399, 400, 401, 402, 403, 404, 405, 406, 407, 408, 409, 410, 411, 412, 413, 414, 415, 416, 417, 418, 419, 420, 421, 422, 423, 424, 425, 426, 427, 428, 429, 430, 431, 432, 433, 434, 435, 436, 437, 438, 439, 440, 441, 442, 443, 444, 445, 446, 447, 448, 449, 450, 451, 452, 453, 454, 455, 456, 457, 458, 459, 460, 461, 462, 463, 464, 465, 466, 467, 468, 469, 470, 471, 472, 473, 474, 475, 476, 477, 478, 479, 480, 481, 482, 483, 484, 485, 486, 487, 488, 489, 490, 491, 492, 493, 494, 495, 496, 497, 498, 499, 500, 501, 502, 503, 504, 505, 506, 507, 508, 509, 510, 511, 512, 513, 514, 515, 516, 517, 518, 519, 520, 521, 522, 523, 524, 525, 526, 527, 528, 529, 530, 531, 532, 533, 534, 535, 536, 537, 538, 539, 540, 541, 542, 543, 544, 545, 546, 547, 548, 549, 550, 551, 552, 553, 554, 555, 556, 557, 558, 559, 560, 561, 562, 563, 564, 565, 566, 567, 568, 569, 570, 571, 572, 573, 574, 575, 576, 577, 578, 579, 580, 581, 582, 583, 584, 585, 586, 587, 588, 589, 590, 591, 592, 593, 594, 595, 596, 597, 598, 599, 600, 601, 602, 603, 604, 605, 606, 607, 608, 609, 610, 611, 612, 613, 614, 615, 616, 617, 618, 619, 620, 621, 622, 623, 624, 625, 626, 627, 628, 629, 630, 631, 632, 633, 634, 635, 636, 637, 638, 639, 640, 641, 642, 643, 644, 645, 646, 647, 648, 649, 650, 651, 652, 653, 654, 655, 656, 657, 658, 659, 660, 661, 662, 663, 664, 665, 666, 667, 668, 669, 670, 671, 672, 673, 674, 675, 676, 677, 678, 679, 680, 681, 682, 683, 684, 685, 686, 687, 688, 689, 690, 691, 692, 693, 694, 695, 696, 697, 698, 699, 700, 701, 702, 703, 704, 705, 706, 707, 708, 709, 710, 711, 712, 713, 714, 715, 716, 717, 718, 719, 720, 721, 722, 723, 724, 725, 726, 727, 728, 729, 730, 731, 732, 733, 734, 735, 736, 737, 738, 739, 740, 741, 742, 743, 744, 745, 746, 747, 748, 749, 750, 751, 752, 753, 754, 755, 756, 757, 758, 759, 760, 761, 762, 763, 764, 765, 766, 767, 768, 769, 770, 771, 772, 773, 774, 775, 776, 777, 778, 779, 780, 781, 782, 783, 784, 785, 786, 787, 788, 789, 790, 791, 792, 793, 794, 795, 796, 797, 798, 799, 800, 801, 802, 803, 804, 805, 806, 807, 808, 809, 810, 811, 812, 813, 814, 815, 816, 817, 818, 819, 820, 821, 822, 823, 824, 825, 826, 827, 828, 829, 830, 831, 832, 833, 834, 835, 836, 837, 838, 839, 840, 841, 842, 843, 844, 845, 846, 847, 848, 849, 850, 851, 852, 853, 854, 855, 856, 857, 858, 859, 860, 861, 862, 863, 864, 865, 866, 867, 868, 869, 870, 871, 872, 873, 874, 875, 876, 877, 878, 879, 880, 881, 882, 883, 884, 885, 886, 887, 888, 889, 890, 891, 892, 893, 894, 895, 896, 897, 898, 899, 900, 901, 902, 903, 904, 905, 906, 907, 908, 909, 910, 911, 912, 913, 914, 915, 916, 917, 918, 919, 920, 921, 922, 923, 924, 925, 926, 927, 928, 929, 930, 931, 932, 933, 934, 935, 936, 937, 938, 939, 940, 941, 942, 943, 944, 945, 946, 947, 948, 949, 950, 951, 952, 953, 954, 955, 956, 957, 958, 959, 960, 961, 962, 963, 964, 965, 966, 967, 968, 969, 970, 971, 972, 973, 974, 975, 976, 977, 978, 979, 980, 981, 982, 983, 984, 985, 986, 987, 988, 989, 990, 991, 992, 993, 994, 995, 996, 997, 998, 999, 1000.

LAST USED	NOT USED
R2	
C1	
C11	C1, 9
R8	
F1	
F2	
F3	
F4	
F5	
F6	
F7	
F8	
F9	
F10	
F11	
F12	
F13	
F14	
F15	
F16	
F17	
F18	
F19	
F20	
F21	
F22	
F23	
F24	
F25	
F26	
F27	
F28	
F29	
F30	
F31	
F32	
F33	
F34	
F35	
F36	
F37	
F38	
F39	
F40	
F41	
F42	
F43	
F44	
F45	
F46	
F47	
F48	
F49	
F50	
F51	
F52	
F53	
F54	
F55	
F56	
F57	
F58	
F59	
F60	
F61	
F62	
F63	
F64	
F65	
F66	
F67	
F68	
F69	
F70	
F71	
F72	
F73	
F74	
F75	
F76	
F77	
F78	
F79	
F80	
F81	
F82	
F83	
F84	
F85	
F86	
F87	
F88	
F89	
F90	
F91	
F92	
F93	
F94	
F95	
F96	
F97	
F98	
F99	
F100	

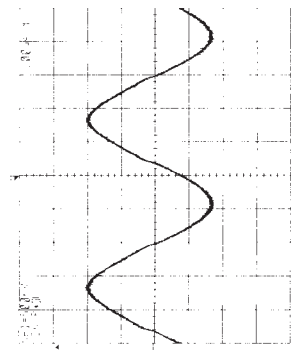

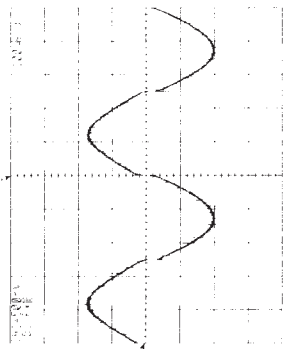
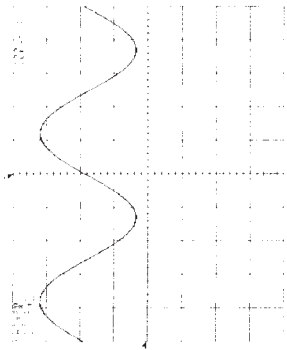
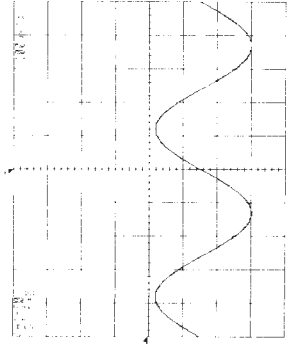

- NOTES:
- BOTH CH. SAME EXCEPT FOR BRIDGING SW (CH 2 SHOWN).
 - ALL RESISTORS 1/4 WATTS 5% UNLESS SHOWN.
 - ALL CAPACITORS IN UF. 100V UNLESS SHOWN.
 - HEAVY LINE SHOWS MAIN SIGNAL PATH.
 - USE QSC REPLACEMENT TRANSISTORS ONLY.
 - FP—FLAME PROOF RESISTORS.
 - Z1—Z6 ZENER DIODES.
 - B1—B3 BRIDGE RECTIFIERS.
 - LD1—LD2 FRONT PANEL LED'S.

- TRANSFORMER AND OUTPUT CONNECTOR PINS
- QUICK DISCONNECT TERMINALS (1-10)

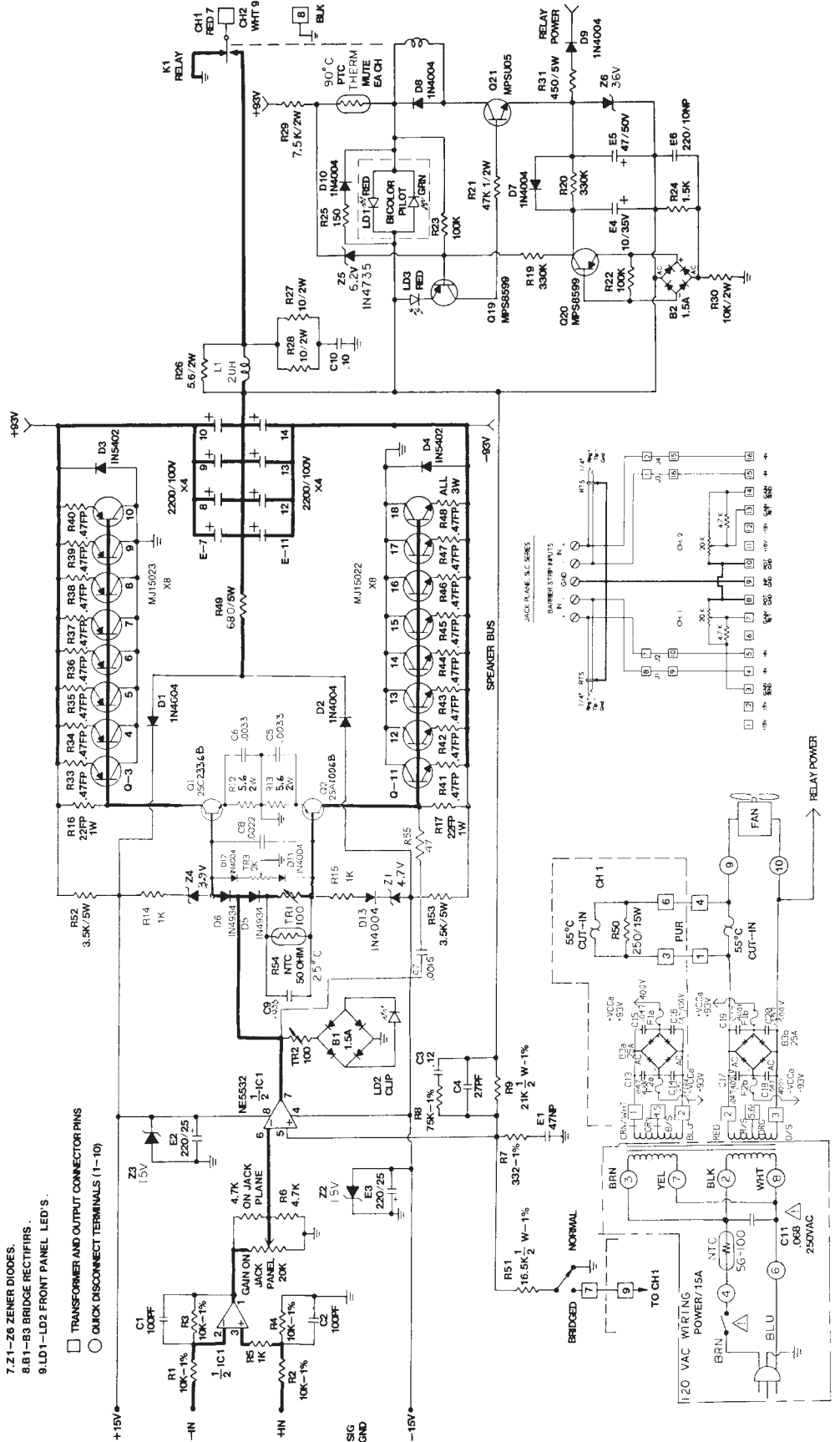

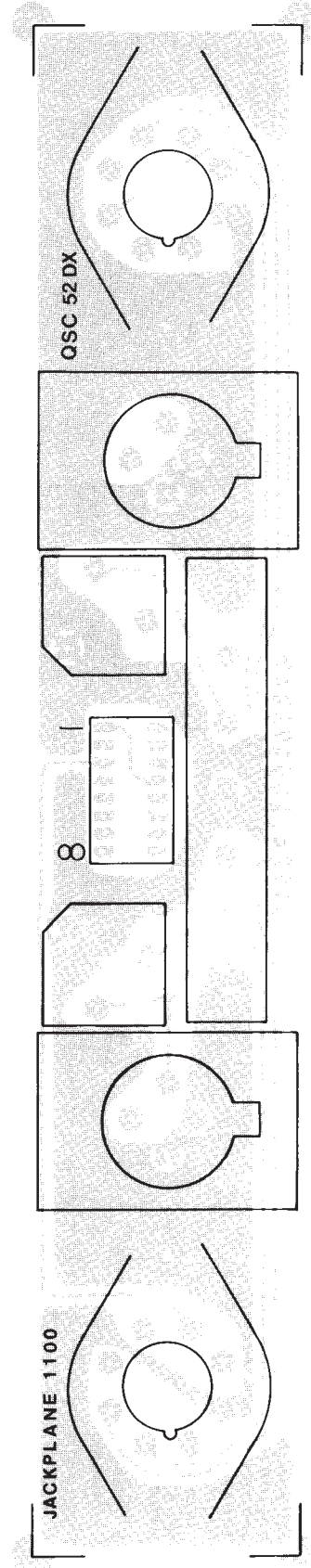
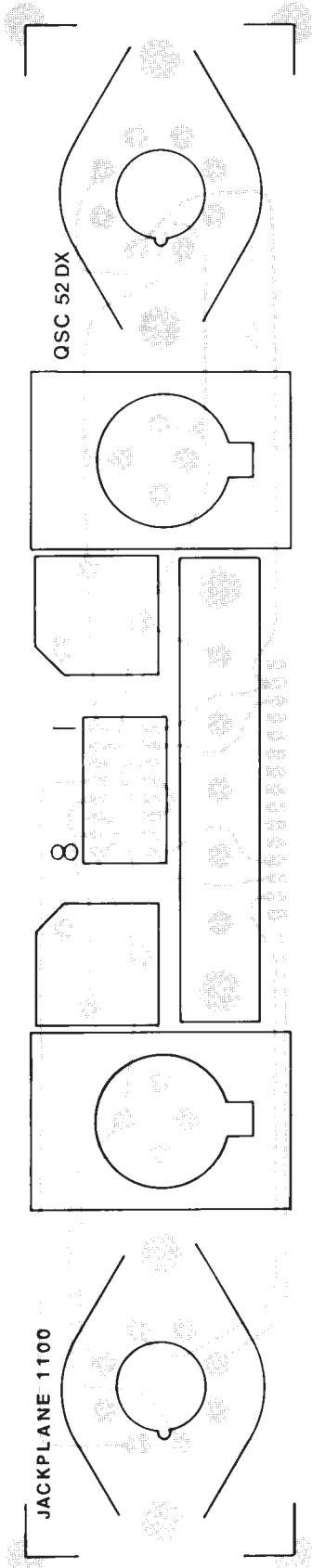

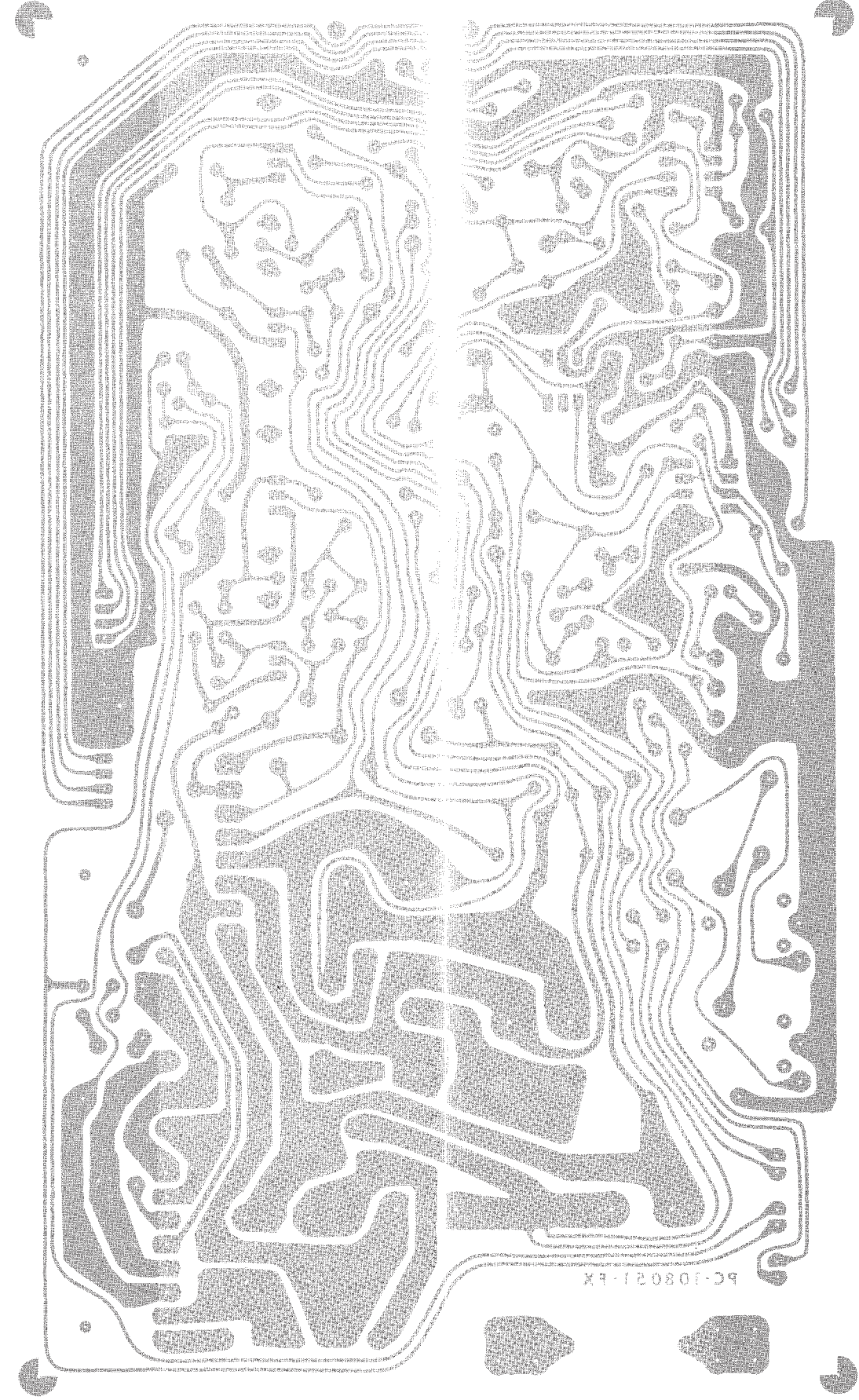
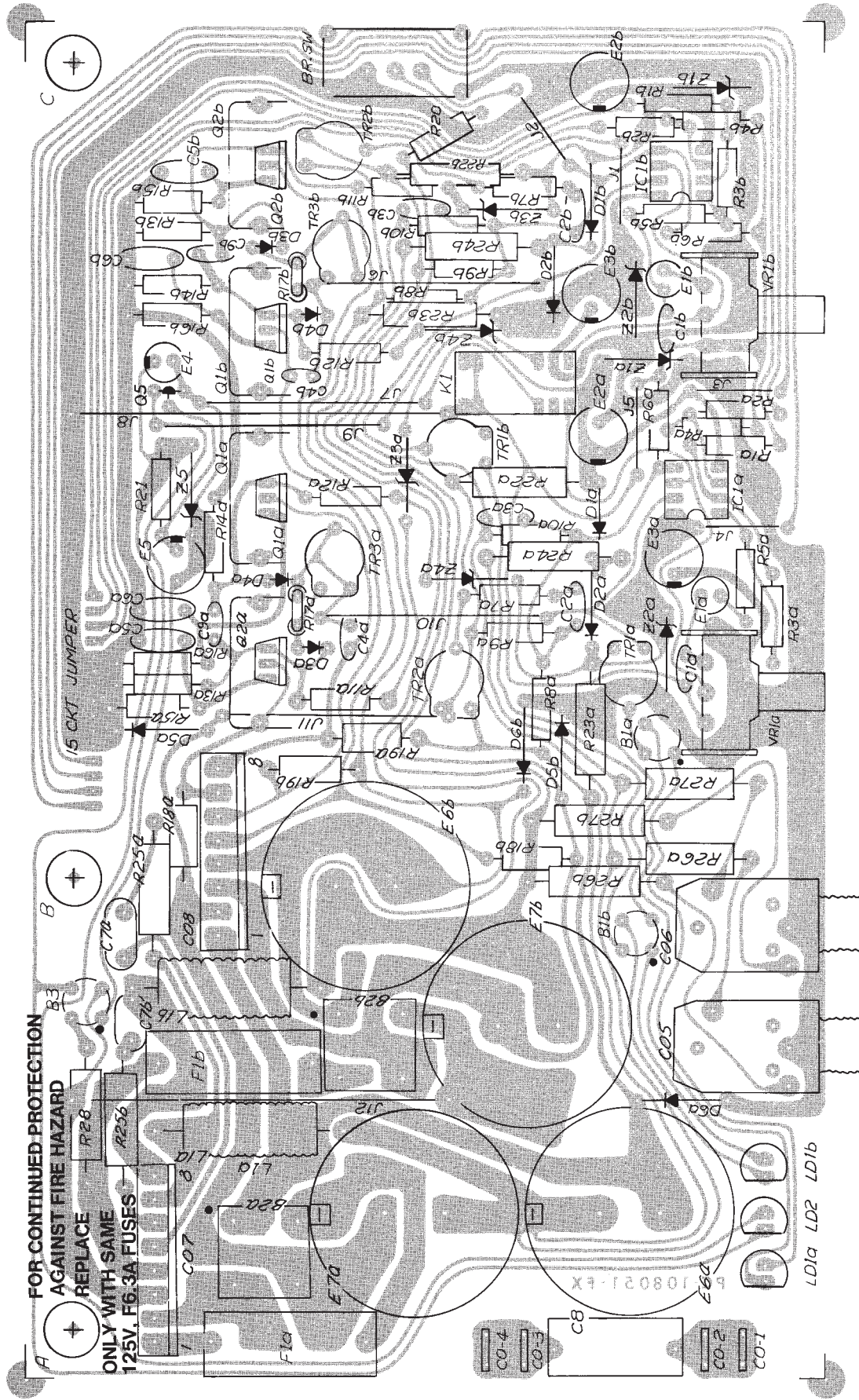

Jackplane PC Solder Side

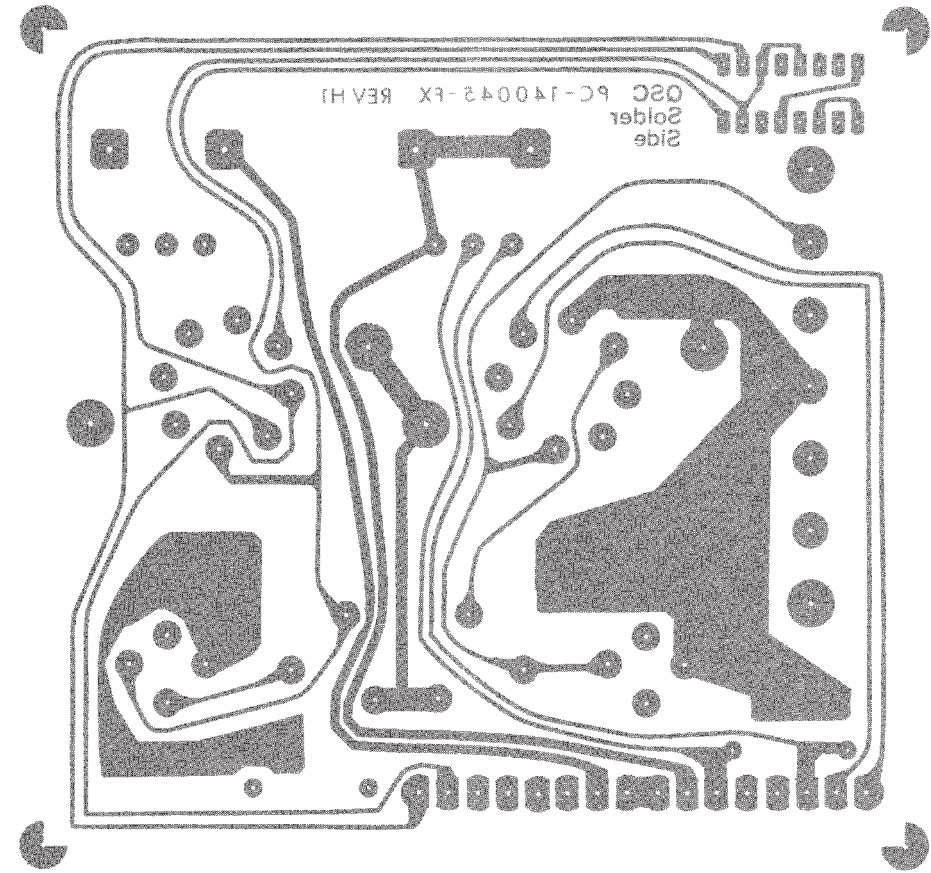

Jackplane PC Parts Side

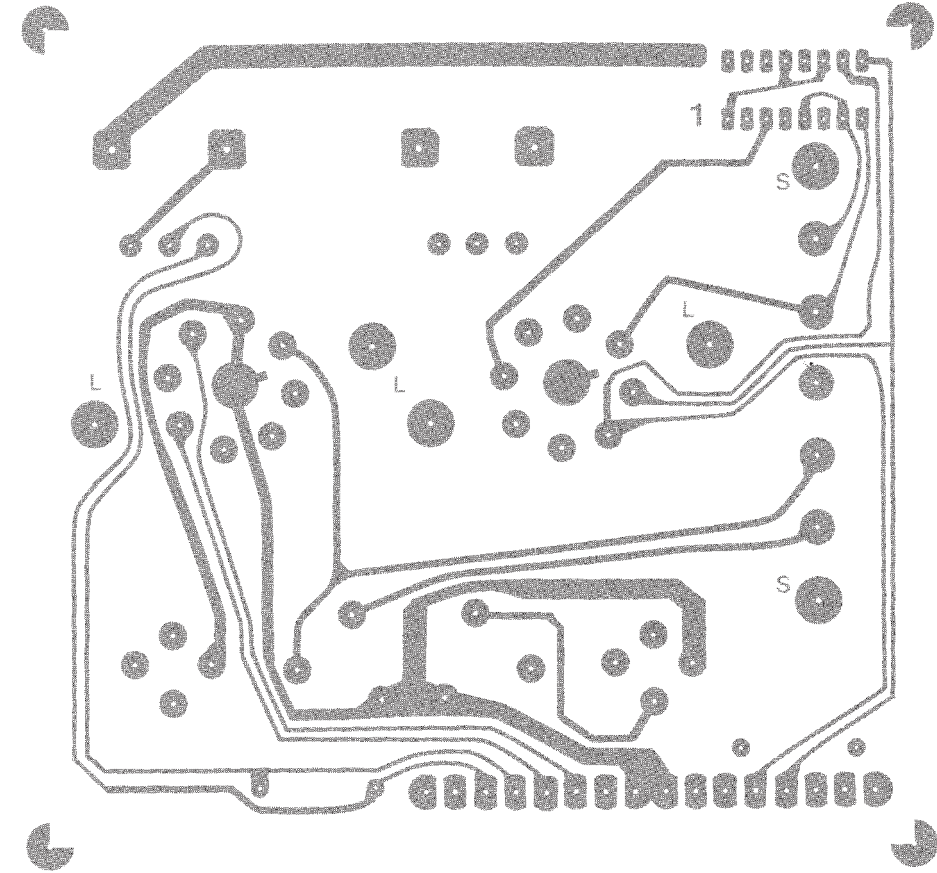

REDUCE TO 50%

