

THIS DOCUMENT CONTAINS PROPRIETARY INFORMATION WHICH IS THE PROPERTY OF QSC AUDIO PRODUCTS, THAT MAY NOT BE DISCLOSED, REPRODUCED OR USED WITHOUT EXPRESS WRITTEN CONSENT FROM QSC AUDIO PRODUCTS.

REVISION				
REV	DESCRIPTION	EFF. DATE	CHK	APPROVED / DATE
A	PRODUCTION RELEASE PER ECO 6959 AA	1-13-06	IO	DD

2. COMPONENTS WITH VALUE PREFIXED WITH A \*\* REPRESENT SMT COMPONENTS.  
 1. THIS DRAWING USED IN CONJUNCTION WITH ASSEMBLY WP-001816-XX.  
 NOTES: UNLESS OTHERWISE SPECIFIED

QTY	ITEM NO.	PART NO.	DESCRIPTION	VENDOR
<b>PARTS LIST</b>				
UNLESS OTHERWISE SPECIFIED DIMENSIONS ARE IN INCHES. DIMENSIONS PER ANSI Y14.5-1982 TOLERANCES ARE: DECIMALS    DECIMALS    ANGLES .xx ±        .xxx ±        0 DEBURR EDGES .XXX R MAX MATERIAL			CONTRACT NO.	<b>QSC AUDIO PRODUCTS, INC.</b> COSTA MESA, CALIFORNIA
FINISH			APPROVALS    DATE	
NEXT ASSY    USED ON			DRAWN PAT QUILTER    6-24-05	<b>SCHEMATIC DIAGRAM</b> <b>HPR181W INPUT BOARD</b>
APPLICATION    DO NOT SCALE DRAWING			CHECKED I. OVERHOLT    X	
			ISSUED D. DELARM    X	SIZE    FSCM NO.    DWG NO.    REV
			CAD SEED FILE NO.    PLOT DATE: Wed Jan 11, 2006	<b>D</b> <b>SH-001815-00</b> <b>A</b>
			SCALE    NONE    CAD FILE NO.    SH1815A1.SCH    SHEET 1 OF 2	

A REV 1 SH-001815-00 DWG NO.



THIS DOCUMENT CONTAINS PROPRIETARY INFORMATION WHICH IS THE PROPERTY OF QSC AUDIO PRODUCTS, THAT MAY NOT BE DISCLOSED, REPRODUCED OR USED WITHOUT EXPRESS WRITTEN CONSENT FROM QSC AUDIO PRODUCTS.

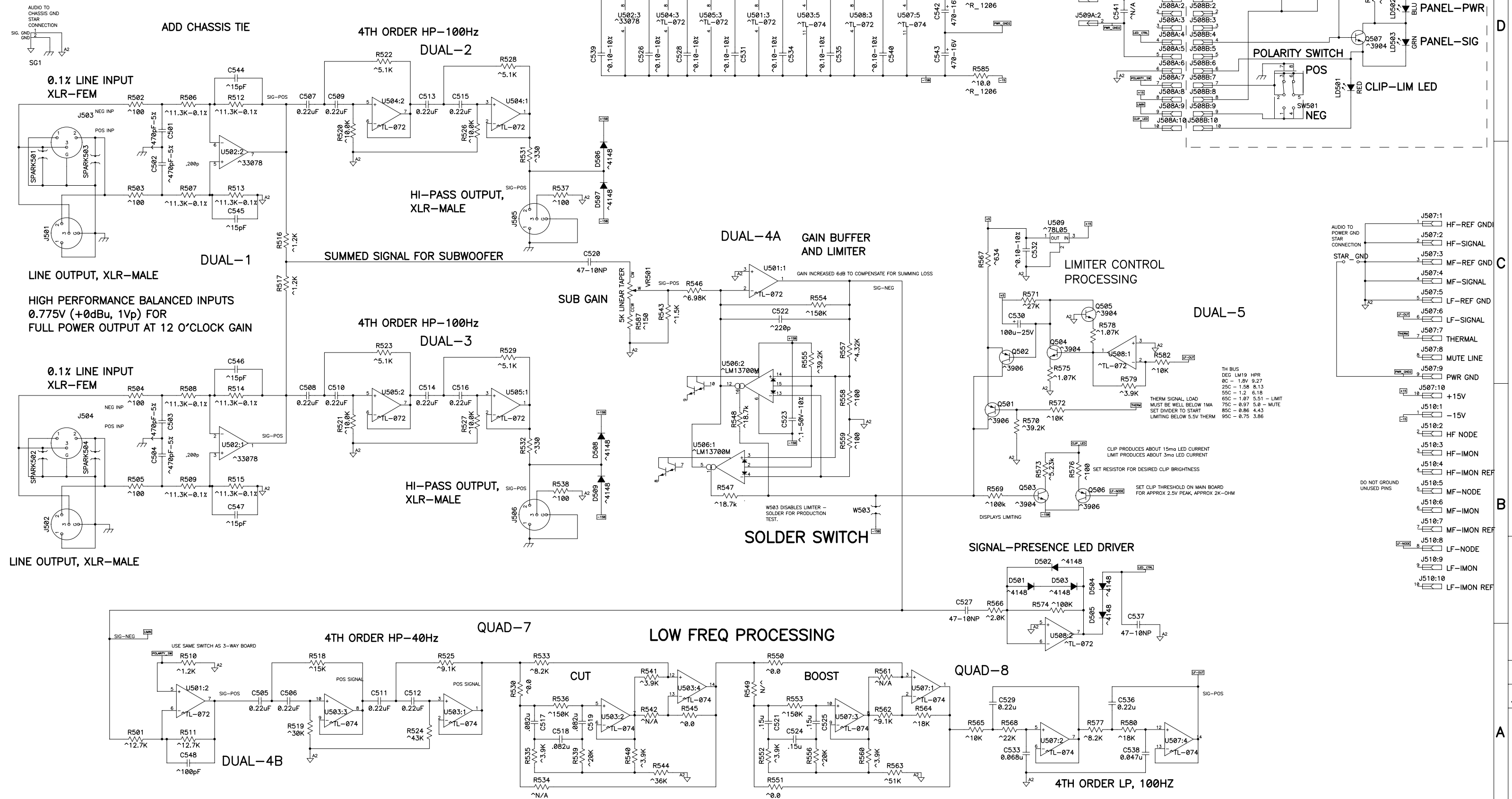

SIZE	FSCM NO.	DWG NO.	REV
D		SH-001815-00	A
SCALE	NONE	CAD FILE NO.	SHEET
		SH1815A1.SCH	2

SH-001815-00