

MKS-70

SERVICE NOTES

First Edition

SPECIFICATIONS

Memory Capacity : a. Patch
Internal Memory : 64
(Memory Cartridge) : 64
b. Tone
Preset : 50
Internal Memory : 50
(Memory Cartridge) : 50

Output : MIX H = +20dBm max/5.1KΩ
M = +5dBm max/8.8KΩ
L = -10dBm max/4.5KΩ
PARALLEL A L 3.3KΩ
R 3.3KΩ
B L 3.3KΩ
R 3.3KΩ

Dimensions : 480(W) x 400(D) x 88(H) mm
18-7/8 x 15-3/4 x 3-7/16 in.

Weight : 7.6 kg/70 lb. 10 oz.

Power Consumption : 32W

Accessories : Connection Cord x 2
MIDI Cable x 2
Memory Cartridge M-64C x 1
Edit Map
Owner's Manual
Guide Book "MIDI"

Options : Programmer PG-800

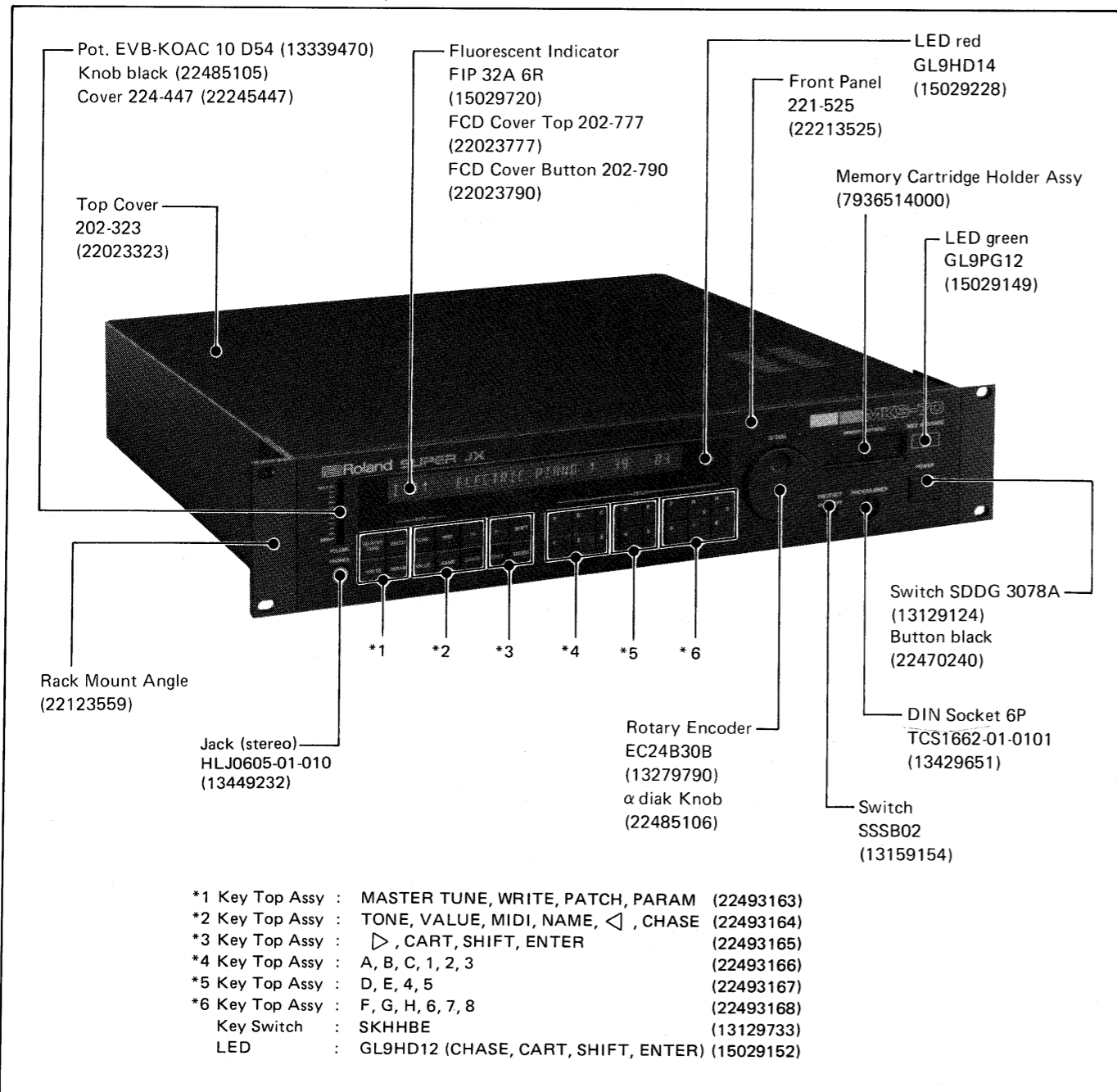
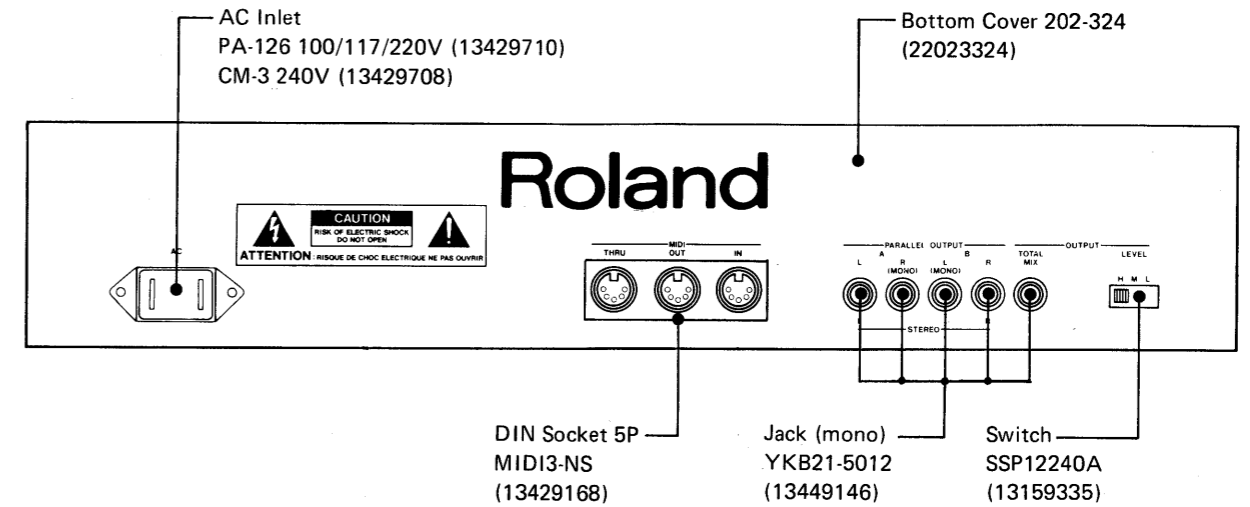

TABLE OF CONTENTS

CAUTIONS
PARTS LIST
EXPLODED VIEW
BLOCK DIAGRAM
CIRCUIT DESCRIPTION
CHANGE INFORMATION
COMPATIBLE PCBS
AND REPLACEMENT CONSIDERATIONS
TEST MODE
ADJUSTMENT
α DIAL BOARD
EMI BOARD (2)
ASSIGNER BOARD
CARTRIDGE BOARD
MODULE BOARD
SWITCH BOARD
DISPLAY BOARD
JACK BOARD
POWER SUPPLY BOARD
FILTER BOARD
EMI BOARD (1)
IC DATA
MIDI

目次

注意事項
パーツリスト
分解図
ブロック図
回路解説
変更案内
基板の互換性
及び交換上の注意
テストモード
調整仕様
アルファダイヤル基板
EMI基板(2)
アサイン基板
カートリッジ基板
モジュール基板
スイッチ基板
ディスプレイ基板
ジャック基板
電源基板
フィルター基板
EMI基板(1)
ICデータ
MIDI

Page
2
2,3
4
5
6,7
7
8
8,9
9
10
10
10,11
12
12,13
14,15
14,15
16
17
17
17
17
18
19-22

CAUTIONS

The following attaching parts are installed to prevent EMI (electromagnetic interference) and, whenever removed during service, must be replaced in the original locations before normal operation use. They must be so installed that PCB's ground points are positively connected to the chassis.

- Lugs (battery contact-like springs) that are attached to the assigner board and the jack board.
- Lugs on the module board.
- Wiring and lug connected to the GND terminal of the stereo phone jack.
- Also positively secure shielding covering the flexible cable between the memory cartridge and CPU board.

注意事項

下記のもの、EMI対策用です。取り外した場合は必ず元通りに取り付け直して下さい。

- アサイナボード及びジャックボードに取り付けてあるバッテリーコンタクト
- モジュールボードに取り付けてある接片
- ステレオフォーンジャックのGND端子に取り付けてある線材及びラグ板
- メモリーカートリッジとCPUボードを結ぶフレキシブルケーブルのシールド処理

PARTS LIST

CASING

22213525	Front Panel	221-525
22193902	Front Holder	219-902
22813563	Sub Chassis	281-563
22023323	Top Cover	202-323
22023324	Bottom Cover	202-324
22193903	Side Holder (Left)	219-903
22193904	Side Holder (Right)	219-904
22123559	Rack Mount Angle	212-559

KNOB, BUTTON

22485106		α dial
22485105		VOLUME
22470240		POWER
22493163	Key Top Assy A	MASTER TUNE, WRITE, PATCH, PARAM
22493164	Key Top Assy B	TONE, VALUE, MIDI, NAME, ◀, CHASE
22493165	Key Top Assy C	▶, CART, SHIFT, ENTER
22493166	Key Top Assy D	A, B, C, 1, 2, 3
22493167	Key Top Assy E	D, E, 4, 5
22493168	Key Top Assy F	F, G, H, 6, 7, 8

SWITCH

13129124	SDDG 3078A	POWER
13129733	SKHHBS	Key
13159154	SSSB02	PROTECT
13279790	EC24B30B	Rotary Encoder
13159335	SSSP12240A	OUTPUT LEVEL

JACK, SOCKET

13449146	YKB21-5012 (MONO)	
13449232	HLJ0605-01-010 (STEREO)	PHONES
13429168	MIDI3-NS (5P DIN Triplet)	MIDI
13429651	TCS1662-01-0101 (6P DIN)	PROGRAMMER
13429710	AC INLET PA-126	100/117/220V
13429708	AC INLET CM-3	240V

POWER TRANSFORMER

22453443U0	245-443U0	100/117/220/240V
------------	-----------	------------------

COIL

12449283	DC-DC Converter	FIP Driver
12449244	SC-02-15E 1.5MHz	Line Filter

RESONATOR

12389737	HC/U 16MHz	(Crystal)	
12389748	CSB600P	(Ceralock)	Display Board

PCB ASSY

7616510000	Assigner Board (See P.8)		
7936518000	EMI Board 1	Power Supply Board	
7936510000	EMI Board 2	6P DIN Socket	
7616507000	Module Board (See P.8)		
7936507000	Power Supply Board		
7936506200	Filter Board	100/117V	
7936506400	Filter Board	220V	
7936506500	Filter Board	240V	
7936510000	Jack Board		
7936512000	Display Board		
7936513000	Switch Board		
7936515000	α -dial Board		

POTENTIOMETER

13339470	EVB-KOAC10 D54	VOLUME
13299193	EVN-D4A A00 B54 (Trimmer)	
13299199	EVN-D4A A00 B13 (Trimmer)	

TRANSISTOR

15119106	2SA733Q	
15129107	2SC945Q	
15119814	2SB1015-O	
15129827	2SD1406-O	
15119601	2SB605L	
151291300G	2SC1583G	
15129613	2SD1207S	
15119819	2SB507E	
15129820	2SD313E	
15129170	2SC945R	

Screened in Gm for Q6, Q7, Q10 of Module Board VCF-VCA Module; dotted in Red, Orange, Yellow or Green. 18 2SC945R's (3 for each voice) on a given Module Board should be of the same color dot for reproducing uniform timbre.

15139103	2SK30ATM-GR	
15119133	DTA114	w/built in bias resistors
15129150	DTC114	w/built in bias resistors

IC

15229830	MB63H149PF-G-BND	Dinamic Gate Array
15179334	TC5564 PL-20	C-MOS Static RAM
15179343F0	MB8416A-12P-SK-G	C-MOS Static RAM
15179807	P-ROM A	Assigner Board
15179808	P-ROM B	Module Board A
15179809	P-ROM C	Module Board B
15179203	HD63B03RP	CPU, Assigner Board
15219150	μ PD7001C	8-bit A/D Converter
15179142F0	MBL8031AH-P-G	CPU, Module Board
15179358	μ PD8155HC-2	8-bit Static RAM
15179185B0	M5M82C54 P-6-D-1	Programmable Counter
15219149	MM5437	Digital Noise Source
15159503	TC40H00P	C-MOS Inverter
15159524	TC40H245P	C-MOS Driver
15159511	TC40H174P	C-MOS D-FF
15159508	TC40H373P	C-MOS Latch
15169301B0	M74LS00P	Quad NAND
15169304B0	M74LS04P	Hex Inverter
15169308B0	M74LS30P	8-input NAND
15169347B0	M74LS32	Quad OR
15169311H0	HD74LS74P	Dual D-FF
15169318B0	M74LS138N	Decoder
15169325B0	M74LS273	8 D-FF
15169327B0	M74LS367AP	Hex Buffer
15169305B0	M74LS08P	Quad 2-input NAND
15169321B0	M74LS161AP	Counter
15159128T0	TC4050BP	Hex Buffer
15159114T0	TC4052BP	Analog Switch
15159115T0	TC4066BP	Quad Analog Switch
15159113D0	BU4051B	Analog switch
15159124H0	HD14093BP	Quad 2-input NAND
15179240	μ PD7538A-013	4-bit CPU, Display Board
15219159	μ PD6300C	FIP Latch Driver
15189171	M5218P	OP Amp
15189154J0	NJM064	Quad OP Amp
15219213	MN-3009	BBD
15169504	MN-3101	BBD Driver
15219157	M5241L	VCA
15189136	M5218L	OP Amp
15229826	IR-3R05	VCF-VCA Pack
15199117	M5230L	V-Regulator

DIODE, LED, PHOTOCOUPLER

15019125	1SS-133	
15019143	1SS-116	
15019323	04AZ9.1Z	
15019605	05Z43Y	
15019607X	05Z6.2X	
15029720	FIP 32A 6R	
15029152	GL9HD12	LED: Red
15029228	GL9HD14	LED: Green, MIDI MESSAGE
15029149	GL9PG12	LED: Green, MONO MODE
15229706	TLP-552	Optoisolator
15019208	1SR-35-200A	Diode, Power Supply Board
15019243	1B4B1	Rectifire Bridge
15019257	4D4B41	Rectifire Bridge

CAPACITOR

13529104	DE7150F472MVA1	Line Capacitor
13549216Y0	0.01 μ F 50V G (\pm 2%)	Film
13529116	DD107SL221G50V (220pF, 50VG)	
13529128	DD107CH680J50V (68pF, Temperature Compensating)	

RESISTOR

13919313	RMLS 8-104J	100k×8 Array
13919321	RMLS 13-103J	10k × 13 Array
13919310	RMLS 8-103J	10k × 8 Array
13919308	RMLS 6-103J	10k × 6 Array
13919147	RMLS 4-103J	10k × 4 Array
13919335	RGLD 6-102J	1k × 6 Array
13919146	RKM 14L 503F	R-2R Array
13919168	RMLS 4-224J	220k×4 Array
13919336	RMLS 8-224J	220k×8 Array
13919322	RMLS 4-102J	1k × 4 Array
13819191	1/2W 560Ω	Solid
13819261	1/2W 470k Ω	Solid

FUSE, FUSEHOLDER

12559409	SD6 630mA	100/117V
12559509	CEE T315mA	220/240V
12199552	UF0005-02	

CONNECTOR HOUSING

13439260	5267-03A	
13439261	5267-04A	
13439263	5267-06A	
13439264	5267-07A	
13439265	5267-08A	
13439269	5267-09A	
13439266	5267-10A	
13439278	5267-11A	
13439267	5267-12A	
13439271	5268-02A	
13439285	5268-03A	
13439272	5268-04A	
13439273	5268-06A	
13439270	5268-08A	
13439318	5268-11A	
13439280	Card Fitting CF-028	Sumi Card Connector
13439315	Card Fitting CF-034	Sumi Card Connector
13439316	Card Fitting CF-127	Sumi Card Connector
13439317	Card Fitting CF-134	Sumi Card Connector
13419546	Stacking Connector 6508-0000EJ	
13419547	Stacking Connector 6512-0000EJ	
13419548	Stacking Connector 6608-6002EJ	
13419549	Stacking Connector 6612-6002EJ	

AC CORD SET (Detachable)

13439825	DC-320-J01	100V
13439812F0	UC-704-J01	117V
13439813F0	EC-210-J06	220V
13439814F0	SC-415-J06	240V: Australian
23495110	5722 660 4606	240V: England BS Certified

COVER, SPACER, HOLDER

22023777	FCD Cover (Top)	202-777
22023790	FCD Cover (Bottom)	202-790
22245447	Slide Pot. Cover	224-447
22240503	Switch Mask	224-503
22163549	Power Switch Spacer	216-549
22163548	Switch Spacer	216-548
22163550	Panel Spacer	216-550
22163545	FIP Spacer	216-545
22193905	Jack Holder	219-905
22195889	MIDI Holder	219-889
22193906	Power Switch Holder	219-906

COLLAR BUSHING

12159734	TA-307 (L=7mm)
12159715	TB-300

FLAT CABLE

13479200	SMCD 28 × 400-BD10P1.25
13479201	SMCD 34 × 400-AD10P1.25

HEAT SINK

22463904	246-904
22463146	246-146
22463155	246-155

WIRING

23493500	Assy A
23493501	Assy B
23493502	Assy C
23493503	Assy D

BOSS NUT

22153577	215-577 (H=8mm)
22153578	215-578 (H=11.5mm)
22153526	215-526 (H=12mm)
22155567	215-567 (H=5mm)

MISCELLANEOUS

22373609	Memory Cartridge M-64C	Sound Backup
7936514000	Memory Cartridge Socket Assy	
13529105	EMI Filter DSS310-55D223S	
13529110	EMI Filter DSS310-55B222M	
12449266	EMI Filter BL01 RN1-A62	
22123222	Power Transformer Plate 212-222	
22125230	Card Plate A	
22125231	Card Plate B	
22325334	Rubber Foot 235-334	
22220319	Power Switch Escutcheon	
12569252	Lithium Battery CR-2450	
13429523	IC Socket SMO-28-S6T	

WIRING

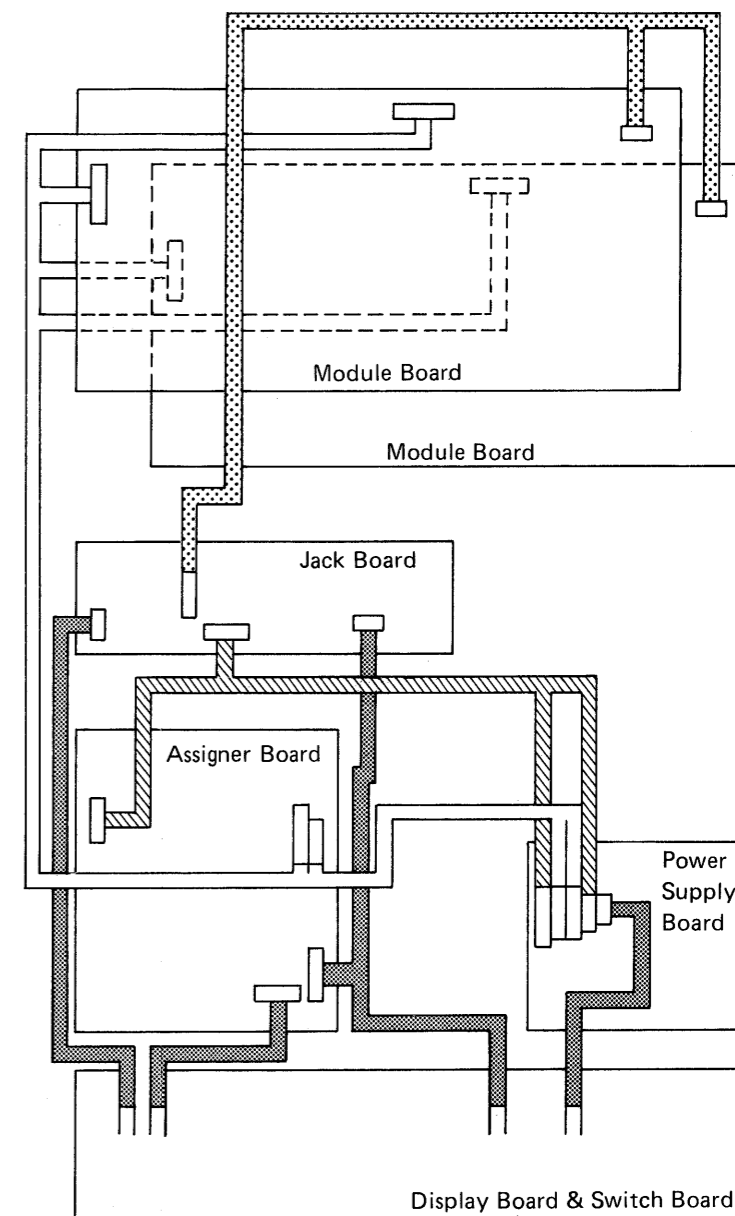

- Wiring A 23493500
- Wiring B 23493501
- ▨ Wiring C 23493502
- == Wiring D 23493503

EXPLODED VIEW 分解図

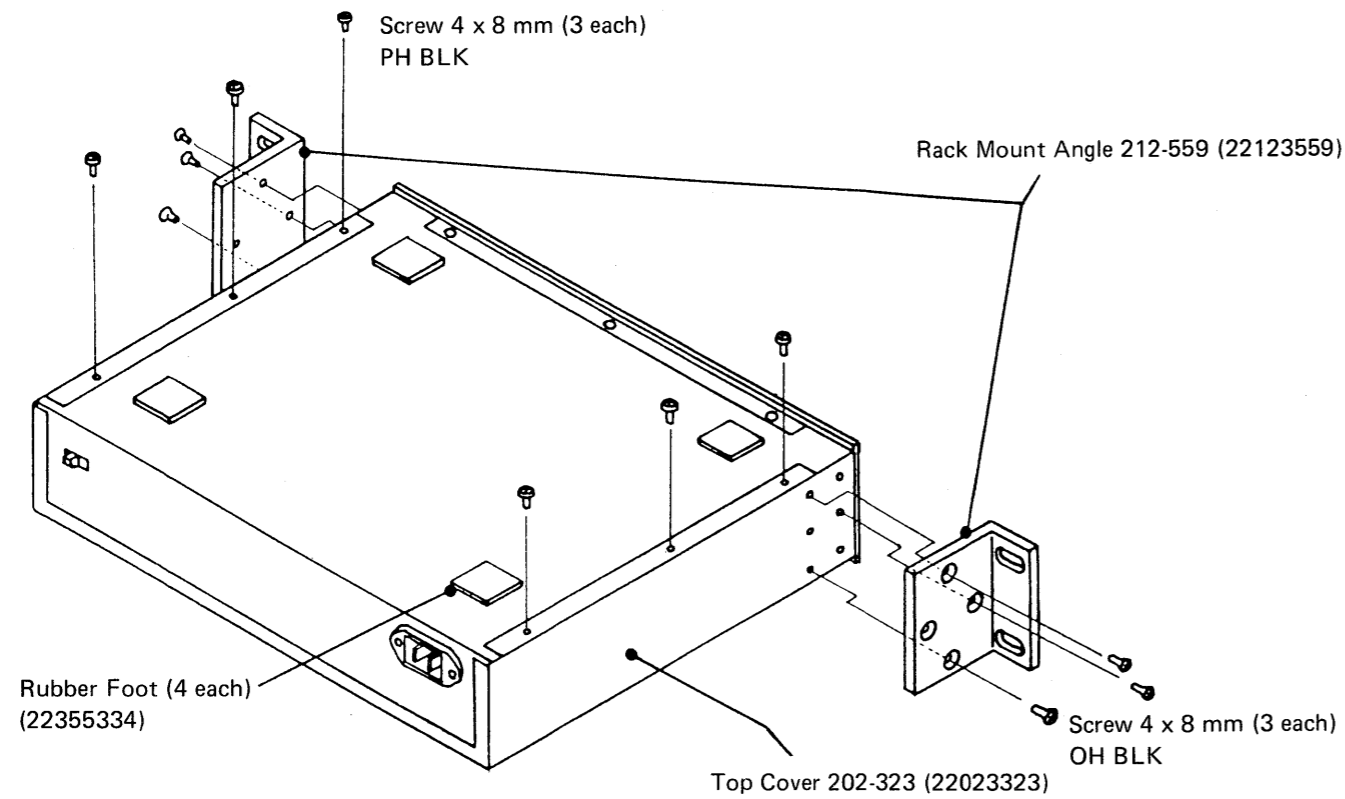
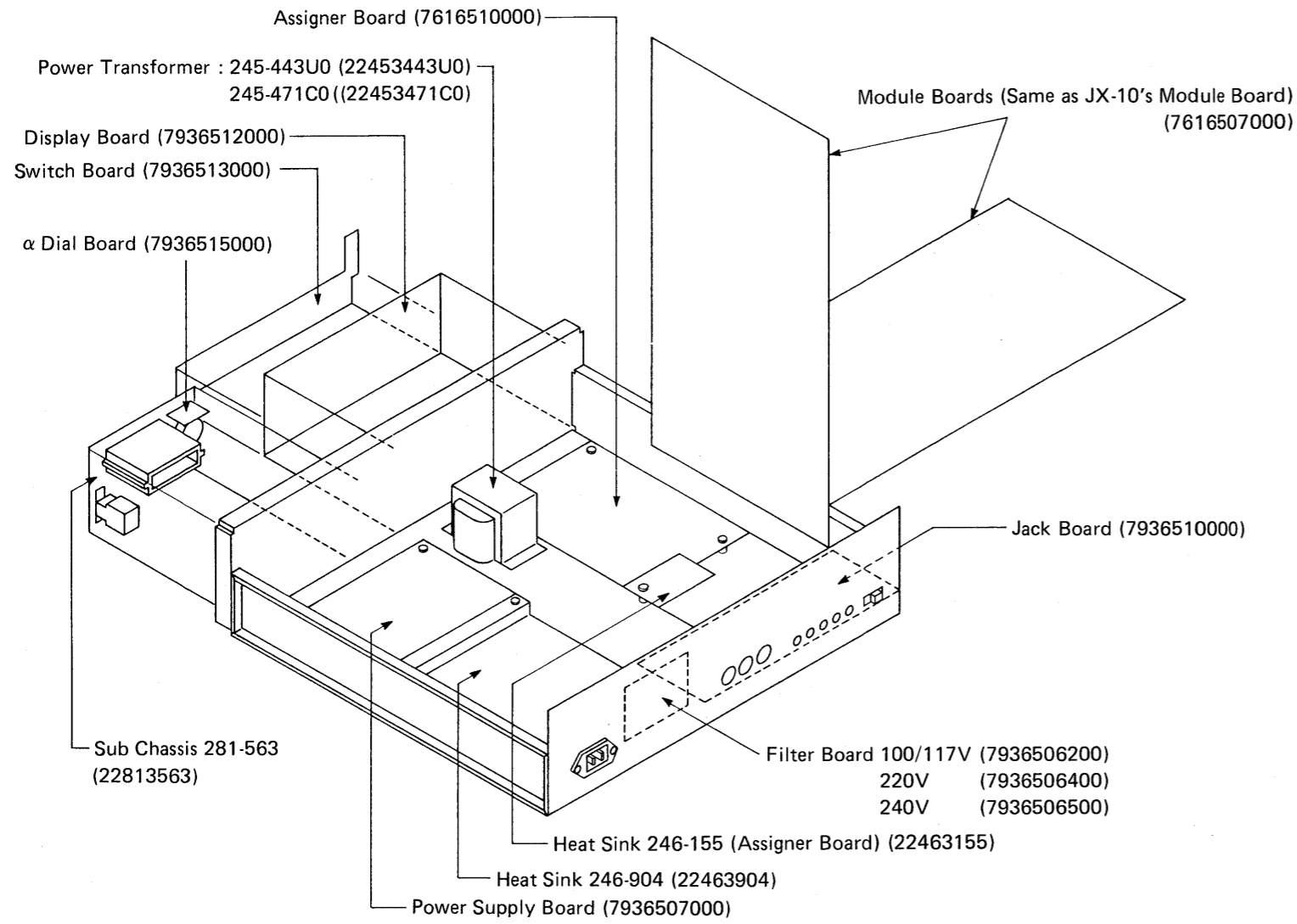

☆: Boss Nut 215-578 (H = 11.5mm)
*: Boss Nut 215-577 (H = 8mm)

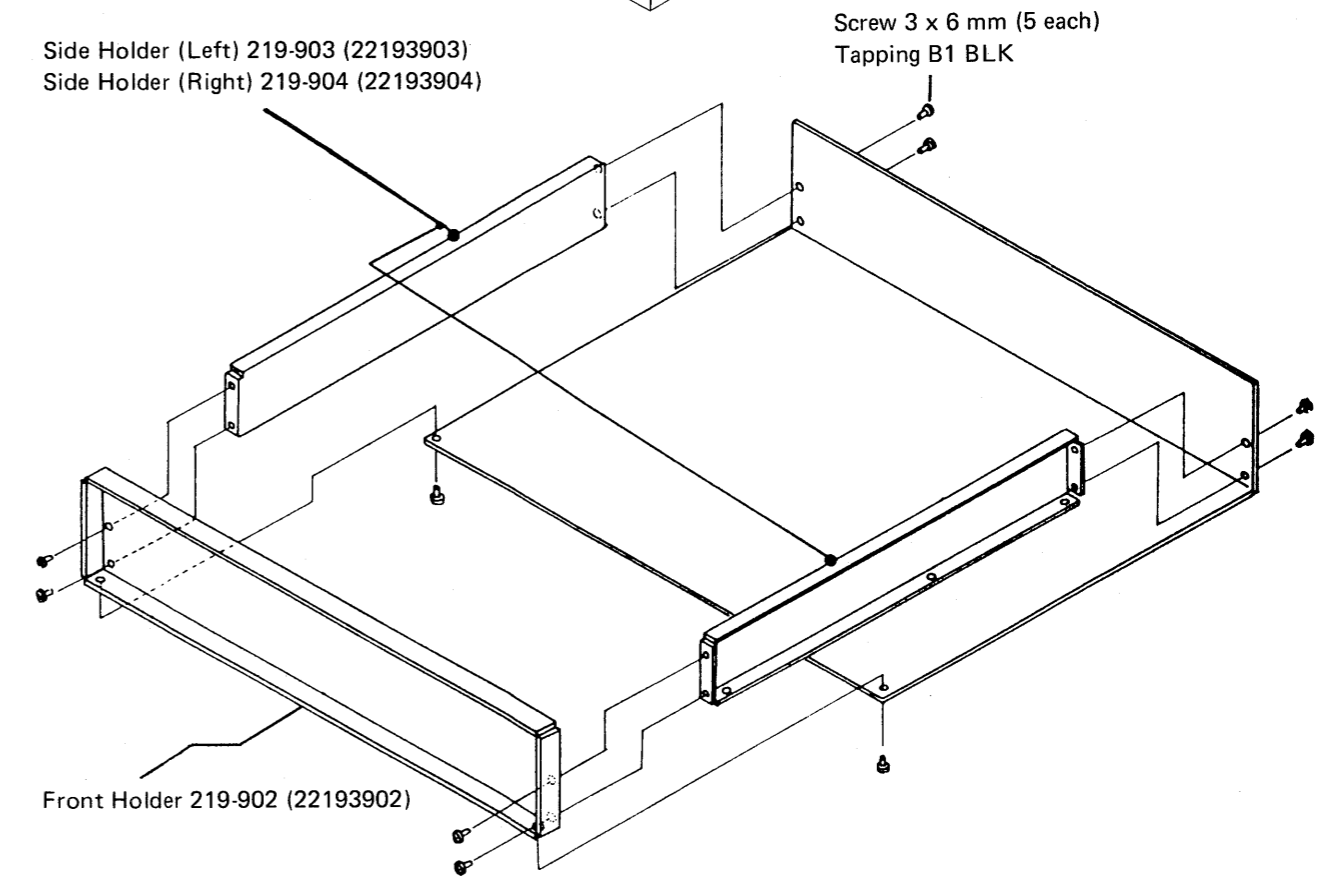
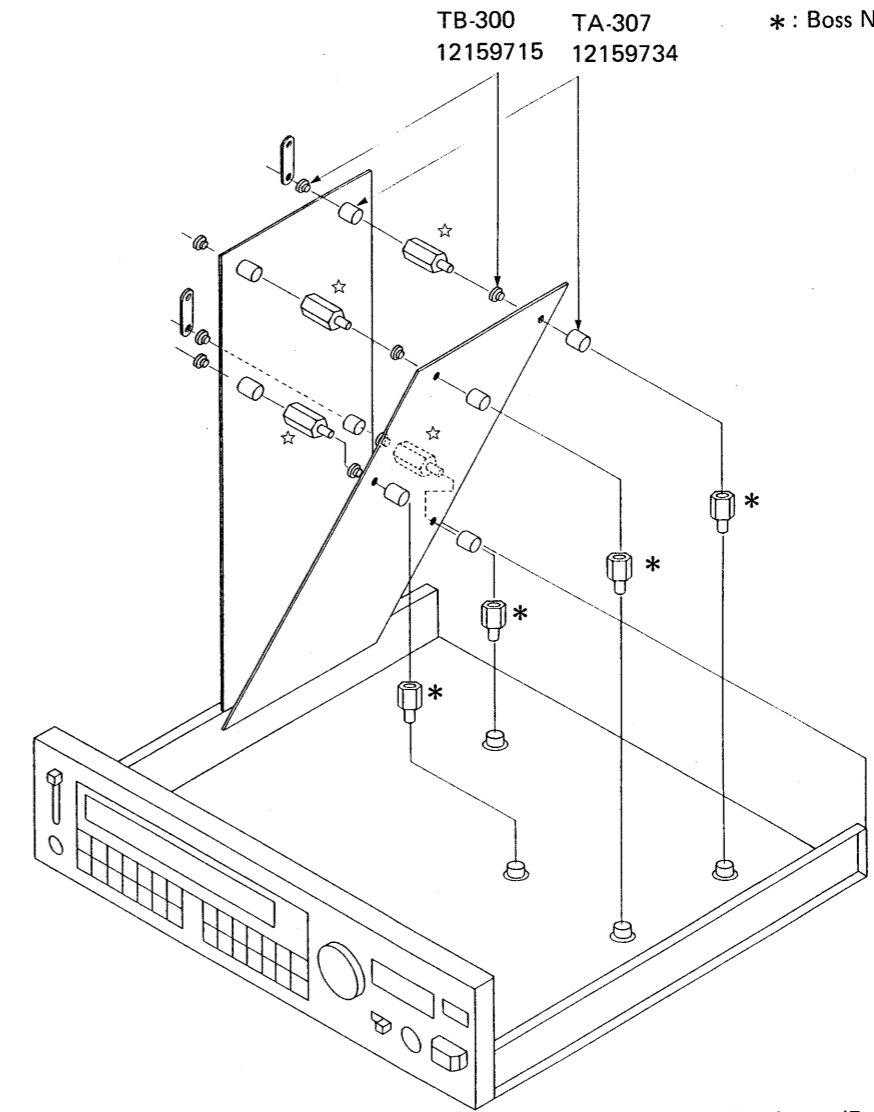

1 2 3 4 5 6 7 8 9 10 11 12 13 14 15 16 17 18 19 20 21 22 23 24 25 26 27 28 29 30 31 32 33 34 35 36 37 38 39

BLOCK DIAGRAM

A
B
C
D
E
F
G
H
I
J
K
L
M
N
O
P
Q
R
S
T
U

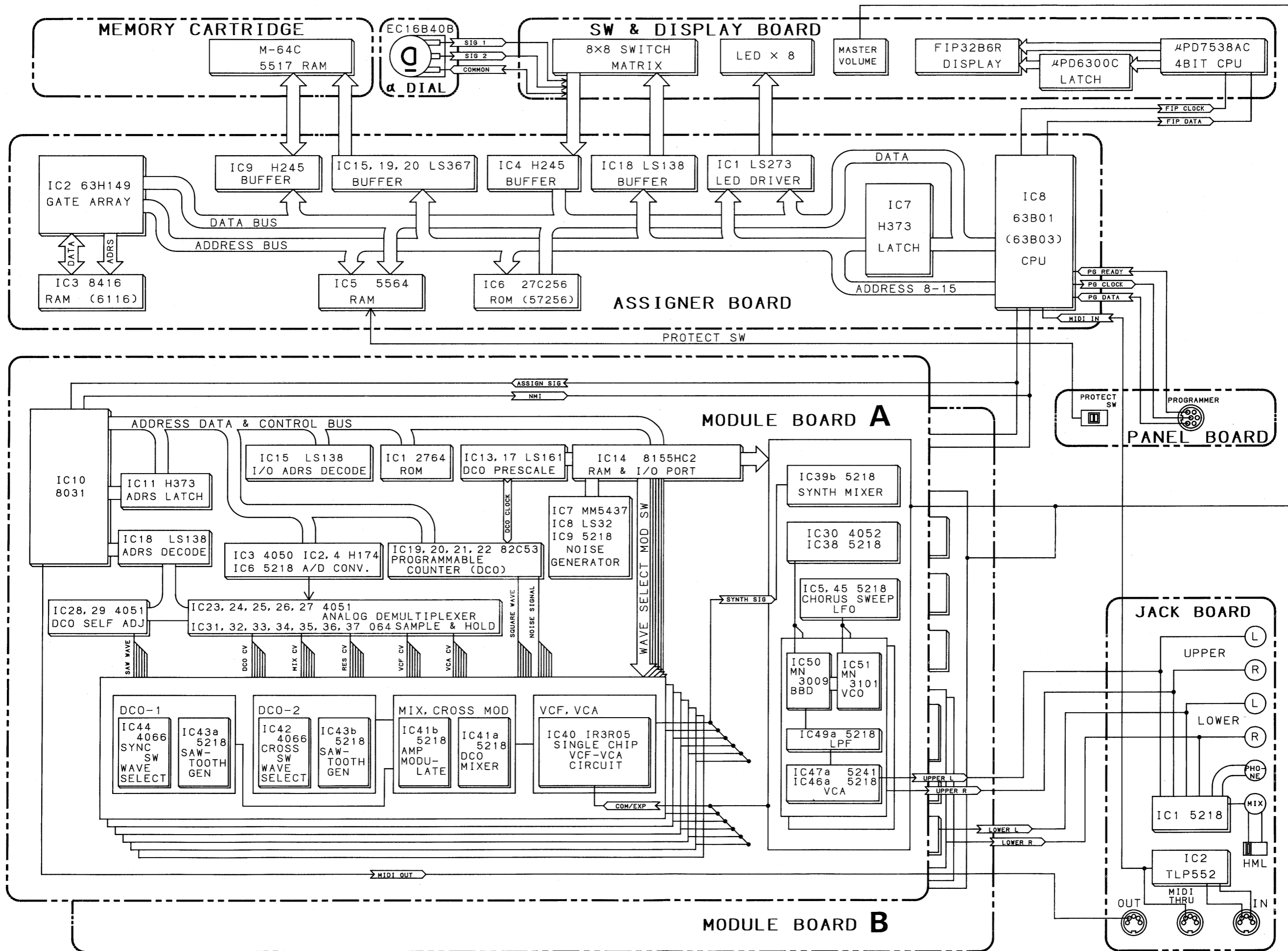

CIRCUIT DESCRIPTIONS

GENERAL

The MKS-70 is a 12-voice (24 DCO, 12 VCF, 12 VCA) synthesizer consisting of the following two systems.

Control System

The system is composed of four CPUs.

Assigner CPU 63B01Master	1 pc
Module CPU 8031Slave	2 pcs
Display CPU μ PD7538ACSlave	1 pc

Voicing System

The system falls into two PCBs: UPPER and LOWER Modules, each caters for 6 voices through the following circuit configuration.

DCO4 programmable interval timers (M5M82C54P), each containing 3 counters.
VCF, VCA6 one-chip VCF & VCA ICs IR3R05
Chorus Circuit	...2 channels

DETAILED

Assigner Board

SWITCH READING

The CPU IC8, 63B01V reads the status of switches through buffers IC18 (LS138) and IC4 (H245).

The switchings are:

- Touch switches on the panel
- Rotary encoder

PROGRAMMER PG-800

The output data from the PG-800 is sent to the CPU IC8 directly in a serial synchronized format.

Module Board

DCOs

DCO 1

The 8MHz clock from the assigner board is first divided at prescaler IC17, LS161 either by 1/2, 1/4, 1/8 or 1/16 according to the DCO range set before being sent to programmable counters IC19 and IC20 (82C54) which further divide the clock down to the object frequency.

回路解説

概要

MKS-70は12ボイス(24 DCO, 12 VCF, 12 VCA)のシンセサイザーであり、主な構成は次の通りです。

制御系

アサインCPU 63B01(マスタ)1個、モジュールCPU 8031(スレーブ)2個、ディスプレイCPU μ PD7538AC(スレーブ)1個の計4個を有しています。

音源系

UPPER及びLOWERモジュール基板には、それぞれ6つのボイスが格納されています。

1枚のモジュール基板には以下のものが内蔵されています。

▲DCO: プログラマブル・カウンタ	M5M82C54P	4個
▲VCF, VCA: ワンチップVCF-VCA IC	IR3R05	6個

▲コーラス回路: 2系統

詳細

アサイン ボード

SW類の読み込み

IC8(63B01V)CPUは、以下のものを、IC18(LS138)及びIC4(H245)のバッファを介し、読み込みます。

- パネルのタクトSW
- ロータリーエンコーダ

プログラマ PG-800

PG-800の出力データは、同期式のシリアル伝送でIC8(63B01V)CPUのポートへ直接送られます。

モジュール ボード

DCO 1

アサインボードから送られてきた8MHzのクロックはIC17(LS161)プリスケラによりDCO設定レンジに応じて、1/2, 1/4, 1/8, 1/16に分周され、IC19, 20(82C54)プログラマブル・カウンタへ送られます。このカウンタは、CPUからのデータによって、クロックを目的周波数まで分周し各モジュールへ出力します。

DCO 2

The DCO 2 has an additional circuit, FINE TUNE put midway between prescaler and programmable counters ICs 21 and 22. The circuit consists of IC12 (LS00) NAND and IC14 (8155) SRAM containing 22 I/Os and a timer and always lowers the clock except when FINE TUNE knob is set at extreme + position. Therefore, the pitch data from the CPU IC10 (8031) contains an offset data so that the frequencies at IC21 and IC22 outputs are in tune when FINE TUNE knob is set at +/-0.

WAVEFORM SHAPER Sawtooth

The circuit generates a series of sawtooth waves to the frequency of a programmable counter output. DC01 and module A are taken as examples.

The square wave T1-A is first differentiated; the positive going pulse forward biases Q9, which in turn discharges C74. The C74 is then charged through IC43 whose output, i.e. charging rate is determined by DC01-A from IC26. The charging rate increases as the note or pitch rises, maintaining the sawtooth amplitude nearly constant over the keyboard range.

Pulse

Increasing DC01-A above overcharge flattens the top of sawtooth. This phenomenon will be made use of when PULS is selected on the panel.

SYNCHRONIZATION

Enabling SYNC allows the positive going pulse derived from T1-A to be applied to DCO-2 counter IC21 through an analog switch IC44, SY-A and GATE pin. The pulse is also routed through D7 to the base of Q9 for synchronizing the DCO-2 sawtooth generator.

VCF AND VCA

A pair of VCF and VCA is fabricated on one chip IC IC40 (IR3R05). VCF is a state variable filter of -24dB/oct LPF. The VCA stage has both LINEAR and EXPONENTIAL control inputs. The LINEAR input accepts VCA CV while the EXPONENTIAL input caters for VCA level and companding CVs.

The 1st VCA inside IC40 (IR3R05) and the 2nd VCA IC47 (5241L) constitute compressor/expander pair and improve S/N ratio.

DCO 2

基本的な動作はDCO1と同様ですが、DCO2の場合は、プリスケラからの出力信号がFINE TUNE回路を介してIC21, 22(82C54)へ送られる点で、異なります。

FINE TUNE回路はIC12(LS00)NANDとIC14(8155)SRAM(22I/O+タイマ付)から構成され、FINE TUNEツマミ(またはパラメーターバリュー)が+側から-側へ移動するにつれプリスケラからの信号周波数を低くしていきます。

[FINE TUNE ツマミ(またはパラメーターバリュー)が中央(±0)を指示している場合(プリスケラ信号の)、周波数はすでに低くなっています。これを補うためIC10(8031)CPUはIC21, 22(82C54)へ補正したデータを送ります。]

波形変換

鋸歯状波

プログラマブルカウンタの出力周波数に同期した鋸歯状波を発生します。以下DCO-1、モジュールAを例にとって説明します。

矩形波T1-Aは微分され正のパルスが発生し、Q8を通じC74を放電します。C74は引き続きIC43により充電されて行きますが、充電速度はDCO-1で定まり、音階が高くなるにつれて早くなります。このためIC43の出力振幅は全音階にわたってほぼ一定に保たれます。

パルス波

DCO1-Aを極端に大きくし、充電カーブの立ち上げを早くすれば、波形の頭が平らとなり下向きパルス波が得られます。

シンクロ

SYNCオンの場合T1-Aから発生したパルスは、アナログSW IC44を通じて、DCO2のカウンタIC21のGATEへ同期用パルス(SY-A)として加えられます。同時にDCO2の鋸歯状波発生回路(Q9を通じて)リセットします。

VCF, VCA

> IC40(IR3R05) ワンチップVCF-VCA IC

VCFの部分はステートバリアブルの2ポールLPFの2段で4ポール -24dB/octの特性があります。

> 最終段VCA IC47(5241L)

IC40(IR3R05)のVCAとIC47(5241L)は、コンプレッション/エキスパンドとして働き、SN比を改善しています。

CHANGE INFORMATION 変更案内

●Pin Functions

- IN ① Signal Input
- FREQ ② } CV Input These CVs determine timbre and level of a sound
- RESO ③ }
- LINE ④ }
- EXPO ⑤ }
- C1 ⑬
- C2 ⑭
- C3 ⑮
- C4 ⑯
- LOAD ⑰

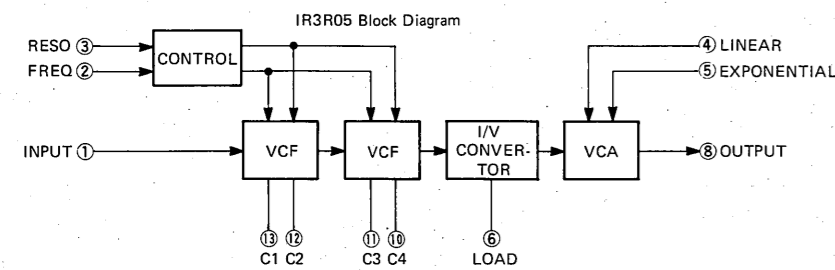

Fig. 1

VCAの部分はLINEARとEXPONENTIALの2つのコントロール入力を持っており、VCA CVはLINEARに、VCAレベルとコンパANDING CVはEXPONENTIAL入力に入ります。各端子は以下の通りです。

- IN ① シグナル入力
- FREQ ② } コントロール入力
- RESO ③ }
- LINE ④ }
- EXPO ⑤ }
- C1 ⑬
- C2 ⑭
- C3 ⑮
- C4 ⑯
- LOAD ⑰

Display Board

ディスプレイボード

■ CPU FOR FIP

IC1 (μPD7538AC-013) directly controls FIP based on the data and command sent from the assigner board CPU (63B01V) which demands additional ports from latch IC2 (UPD6300C).

■ FIP用CPU

IC1 (μPD7538AC-013) CPUは、アサインボードのCPU(63B01V)から送られてきた同期式のシリアルデータ及びコマンドをもとに、FIPを直接コントロールしています。

IC2 (μPD6300C) LATCHは、FIP用CPUのポート不足分を補っています。

■ ROTARY ENCODER INTERFACE

Output signals from rotary encoder are first fed to IC1 (HC14), shmitt trigger where they are routed to LATCH and CLK pins of IC2 (LS74), respectively. CLK and Q outputs from IC2 are read by software scanning through the switch buss 6 and 7, in the same manner as other switches.

■ ロータリーエンコーダ、インターフェイス

ロータリーエンコーダの2信号出力はIC1(HC14)シュミット・トリガを介し、1つはIC2(LS74) LATCHのデータに、もう1つはCLKに接続されています。

IC2 LATCHのCLKとQは、SW BUS 6, 7に接続されており、他のSWと同様にソフトウェア・スキャンされます。

Assigner Board ROM Version

ROM(A)Version NO.	Serial Number	改善された症状	What is cured
1.00	Prior to 710150		
1.01	720150 720236	Even if KEY MODE has been set in DUAL (MIDI information is to be received by the MKS-70 only when sent on a channel that is being the basic channel of the channel A.), the following messages on the basic channel for channel B are illegally received: HOLD, MODULATION and BEND Occasional failure in entering a KEY ASSIGN setup for channel A in the edit mode.	<ul style="list-style-type: none"> • KEY MODE が DUAL の設定 (チャンネル A 側に設定されているベーシックチャンネルの MIDI 情報のみ受信するモード) にもかかわらず、チャンネル B 側に設定してあるベーシックチャンネルの HOLD, MODULATION, BEND の MIDI 情報を受信してしまう。 • MIDI のチャンネルモードメッセージの MONO / POLY を受信しても切り換わらない事がある。 • TONE A 側の KEY ASSIGN の設定が書き込めない。
1.02	720237 720349	With KEY MODE set at T-VOICE or X-FADE, a NOTE ON MIDI information with low velocity value fails to light MIDI MESSAGE LED. Changing modes from parameter No. 24 "DCO 2 TUNE" to PATCH edit during TONE editing causes a disordered program run.	<ul style="list-style-type: none"> • KEY MODE が T-VOICE 又は X-FADE の設定時、ノート・オンのベロシティ値が低い MIDI 情報であると、受信しているにもかかわらず MIDI MESSAGE LED が点灯しない。 • TONE のエディットにパラメータ No. 24 "DCO 2 TUNE" を指定し、その状態から PATCH のエディットモードへ移行すると暴走する。
1.03	720350-UP	The MKS-70 illegally receives PATCH PROGRAM CHANGE on a channel not specified by CONTROL CHANNEL during OMNI OFF, MONO mode (the receiving OMNI mode of MKS-70 is OFF only). Assuming that PATCH PROGRAM CHANGE is being attempted in OMNI OFF, MONO mode. Sending program change information in a row at short intervals on a channel specified by CONTROL CHANNEL sometimes generates a tone other than the tone to be fetched from PATCH memory. * Adding BEND RANGE Initialization Feature	<ul style="list-style-type: none"> • OMNI OFF, MONO モード時 (MKS-70 の OMNI モードは OFF のみです) PATCH PROGRAM CHANGE を CONTROL CHANNEL で設定した以外のチャンネルでも受信してしまう。 • OMNI OFF, MONO モード時、PATCH PROGRAM CHANGE を行なう場合、CONTROL CHANNEL で設定したチャンネルのプログラム・チェンジ情報が連続で数回送られかつ、その時間間隔が極端に短いと、PATCH メモリー内で記憶した TONE に正常にならない事がある。 • MIDI 又は本体で MONO/POLY 切り換えを行なうと TUNE がずれてしまう。 • OMNI OFF, MONO モード KEYMODE = SPLIT の時、ピッチベンド情報を受けてもベンダー効果が働かない事がある。 • Fig 2 のような MIDI のメッセージを受けた時、斜線部分では発音すべきであるのに発音しない。

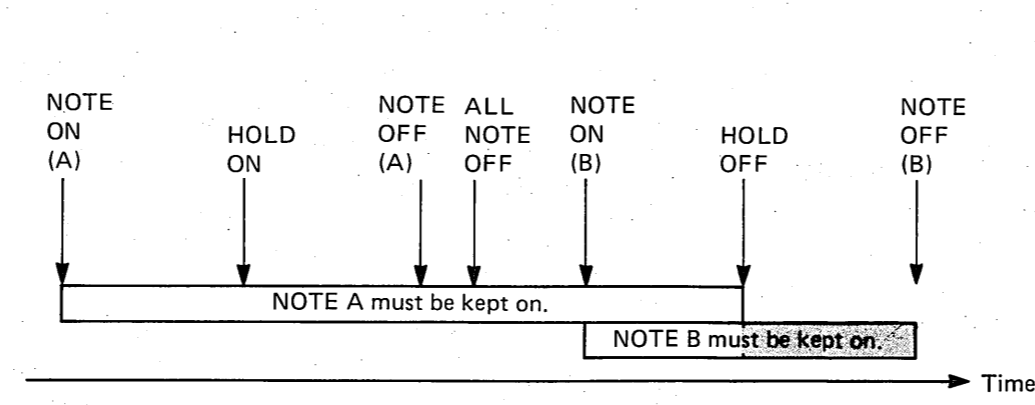

Fig. 2

*BEND RANGE Initialization
This feature enables setting of all patch memories (64 patches) to have BEND RANGE values 2 or 12. This function will overwrite portions of internal memory data: The existing data should be saved on RAM cartridge, as necessary, before.
This initialization does not affect RAM cartridge data.
Setup Procedure
A. To set BEND RANGE to 12
Pressing [SHIFT] and [>] buttons, turn the MKS-70 on.
B. To set BEND RANGE to 2
Pressing [SHIFT] and [◀] buttons, turn the MKS-70 on.

*BEND RANGE 初期化設定機能
本体内存すべてのパッチメモリー(64パッチ)の BEND RANGE 値を 2 又は 12 に設定するものです。
注意 (1)この設定を行なうと、本体内存データの一部を書き換えてしまいます。従ってユーザーのデータ保存が必要な場合は、この設定を行なう前に必ず RAM カートリッジにデータをコピーしておいて下さい。
(2)この設定機能で書き換えを行なうのは本体内存のみであり、RAM カートリッジは一切関係しません。

設定の仕方
Ⓐ BEND RANGE 値を 12 に設定する場合。
[SHIFT] , [>] のボタンを同時に押しながらか電源を入れる。
Ⓑ BEND RANGE 値を 2 に設定する場合。
[SHIFT] , [◀] のボタンを同時に押しながらか電源を入れる。

COMPATIBLE PCBs AND REPLACEMENT CONSIDERATIONS

Assigner board and module board are, respectively, compatible with one for JX-10. Engineering changes and differences in software (ROM) and small attaching parts will impose a degree of limitation when substituting a pcb. The below discusses compatibility considerations in details.

Module Board (See Table A)

PCB ASSY No.	PCB No.	Description 変更内容	JX-10	MKS-70
7616507000	pcb 22923302 00		Works 使用可	Does not work 使用不可
	pcb 22923302 01	Re-layout to accomodate changed parts 部品変更等によるパターン修正		
	pcb 22923302 02	Re-layout to accomodate changed parts 部品変更等によるパターン修正		
	pcb 22923302 03	Re-layout to accomodate changed parts 部品変更等によるパターン修正		
	pcb 22923302 04	Provide holes to attach to a hinge exclusively used on MKS-70. MKS-70に取り付けるための蝶番用穴追加		
			Works 使用可	

Table A

Common PCB

PCBs part numbered 22923302 04 and above

Replacement PCB

An order for module board of MKS-70 or JX-10 will be filled with 22923302 04 or above.

NOTE

PCBs numbered 22923302 03 and below are exclusive to JX-10 since hinge mounting holes required by MKS-70 are not provided in these PCBs.

CAUTIONS ROM

ROMs are different in program not only between models, but also between modules (A and B . . . MKS-70; UPPER and LOWER . . . JX-10).

EMI-Preventing Hardware

— locations differ between models — Springs (substituted for by battery contact, etc.) connecting return paths to the chassis are for preventing EMI (electromagnetic interference). Before replacing PCB, compare the locations of those parts on both existing and replacement; change arrangement on the replacement, if not inconsistency exists.

基板の互換性及び交換上の注意

MKS-70及びJX-10のModule Board, Assigner Boardは両機種に共通ですが変更等により互換性のない場合もありますので以下の点に注意して下さい。
(変更内容も併記してありますので参考にして下さい。)

モジュールボードについて (Table A 参照)

- pcbコードが22923302 04以降の基板のみ共通使用可能です。
- 補足: pcbコードが22923302 03以前の基板は蝶番用の穴が無いためMKS-70では使用できません。

交換上の注意

- 補修用としてはpcb 22923302 04以降(MKS-70, JX-10共通使用可能)のものが供給されます。
- ROMについて
機種間及びモジュール間(MKS-70の場合はモジュールA, B間, JX-10の場合はモジュールのUPPER, LOWER間)での互換性は全くありません。
- EMI対策部品について
基板にはEMI対策部品(バッテリーコンタクトを流用したもの及びその他)が取付けられており機種により取付位置が異なります。
基板交換時、差し換え基板上的取付位置が修理品の元の基板と同じになるように必ずEMI対策部品を取り付け直して下さい。

Assigner Board (See Table B)

PCB ASSY No.	PCB No.	Description 変更内容	JX-10	MKS-70
7616510000	pcb 22923303 00		Works 使用可	Does not work 使用不可
	pcb 22923303 01	Pattern re-layout パターン修正		
	pcb 22923303 02	Pattern re-layout パターン修正		
	pcb 22923303 03	Pattern re-layout パターン修正		
	pcb 22923303 04	Pattern re-layout パターン修正		
	pcb 22923303 05	Make common to MKS-70 and JX-10 by changing artwork 共通仕様にするためのジャンパーパターン追加		Works 使用可
	pcb 22923303 05	Exclude parts not required by MKS-70 MKS-70における不要部品削除	Does not work 使用不可	Works 使用可

Table B

Common PCB

PCB part numbered 22923303 05 and above with all designations filled with component. (See NOTE and CAUTIONS.)

Replacement PCB

An order for assigner board of MKS-70 or JX-10 will be filled with the one described above.

NOTE

Even part numbered 22923303 05 and above, PCBs lacking C11-C30, CN2-CN5, and IC21 and related components are exclusive to MKS-70 (with SN741300).

Cautions on PCB replacement

- ROM
ROMs on both models are incompatible with each other.
- Jumper
Jumper pads, J1 must be as follows.
JX-10 open
MKS-70 short
- EMI-preventing system
As stressed earlier in Module Board section, this system must be re-buit on the substitutive PCB.

アサインボードについて (Table B 参照)

- pcbコードが22923303 05以降でかつ全部品が実装済みの基板のみ共通使用可能です。
- 補足: ① pcbコードが22923303 04以前のものはJX-10専用でパターンが異なります。
- ② pcbコードが22923303 05以降であっても、一部の部品(C11-C30, CN2-CN5, IC21とその周辺回路)が実装されていないものはMKS-70専用(SN741300以降のMKS-70に使用されているもの)です。

交換上の注意

- 補修用はpcb 22923303 05以降でかつ全部品実装済(MKS-70, JX-10共通使用可能)のものが供給されます。
- ROMについて
機種間での互換性は全くありません。
- ジャンパー(J1)について
下記の様に機種に応じた処理を必ず行って下さい。
JX-10 — OPEN
MKS-70 — SHORT
- EMI対策部品について
基板にはEMI対策部品(バッテリーコンタクトを流用したもの及びその他)が取付けられており機種により取付位置が異なります。基板交換時、差し換え基板上的取付位置が修理品の元の基板と同じになるように必ずEMI対策部品を取り付け直して下さい。

TEST MODES

The MKS-70 can be put into one of or a combination of three test modes in which some adjustments and functional checkings can be carried out.

Mode 1. Assigner Section Test

Enter this mode whenever the unit stays on one of the messages, 1-3, shown in Fig. 3 and won't step to the next message after power-up. This test mode checks whether the assigner board is intact or not. (When the unit is powered up for normal operation mode, CPUs in modules A and B monitor chips under their control and take compensating and adjusting procedures as necessary. Upon completion of such routines, they send a ready signal to the assigner CPU, respectively. Without the ready signals the assigner CPU stalls and goes hangup.) This test routine allows the assigner CPU to operate irrelevantly to existence or absence of such ready signals.

テストモード

MKS-70には3通りのテストモードがあり、調整及び機能チェックに応用することができます。

1. アサイン部点検モード (ハングアップ時)

電源を投入したときにMKS-70がFig. 3 ①, ②, ③のいずれかを表示したままで次の動作へ進まない場合、本テストモードを用いることにより、アサイン部だけの動作が可能か不可能かを調べることができます。「通常での電源投入時、モジュールCPUはまず自身が管理する各チップを点検し、バラツキの補正や調整を行なった後、準備完了信号をアサインCPUへ送ります。2個のモジュールCPU(A及びB側)からの信号が送られてこないとアサインCPUはハングアップしてしまいます。このテストモードはモジュールCPUから準備完了信号を受け取らなくてもアサインCPUが次の動作を行なえるようにするものです。」通常の電源投入時、正常のディスプレイ表示進行はFig. 3のようになります。

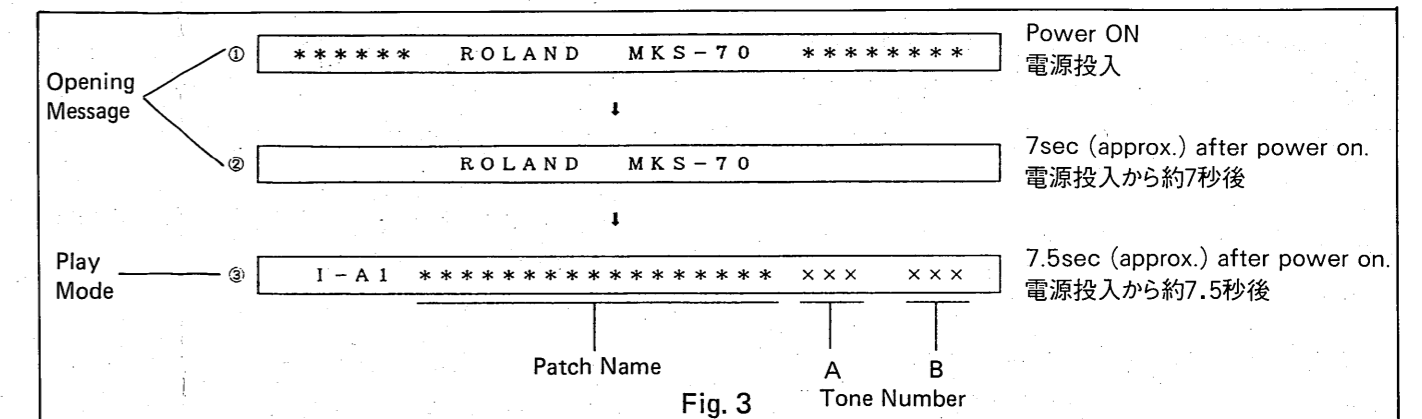

Fig. 3

Entering Test Mode 1

Pressing WRITE button, turn the power on. Consulting Table 1, compare the sticking reading with that previously shown in the normal operation mode.

モードへの入り方

WRITE ボタンを押しながら電源を入れる。

<参考>

通常の電源投入後及び本テストモード操作による電源投入後のディスプレイの状態によってどの部分が異常であるか大まかに推定できます。(Table C)

MKS-70 goes hangup at: (See Fig. 3)	Suspectie
After Normal Power-up One of the followings: No message message 1, 2, 3	Assigner board Display board
message 1 message 2	module board A (sound block A) module board B (sound block B) Pot reading (A/D)

各操作におけるディスプレイの状態		推定内容
通常に電源を入れる 立ち上がらない、または表示①②③のいずれかでハングアップ	本テストモードで電源を入れる 立ち上がらない、または表示①②③のいずれかでハングアップ	アサインボードまたはディスプレイボードの動作不良
表示①の状態でもハングアップ	表示③の状態まで正常に進行する	モジュールボードA,B(音源ブロックA, B)の動作不良
表示②の状態でもハングアップ	表示③の状態まで正常に進行する	VRの読み込み(A/D)関連の動作不良

Table C

Mode 2. Active Module Identification

The module currently producing voice (that is being assigned to the input MIDI ON) will be displayed while in this mode. The module (A-F) and its sound block (A or B, i.e. module board A or B) is represented at the pre-determined place on the display window as shown in Fig. 4.

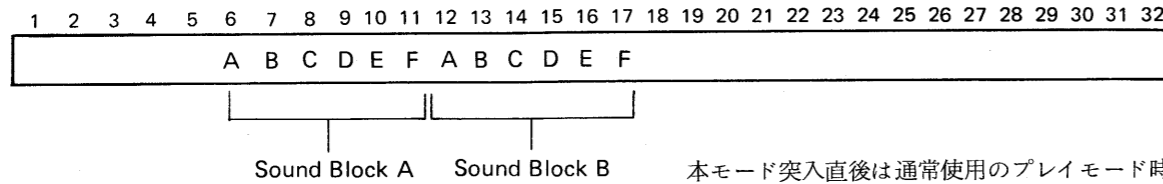

Fig. 4

Entering Test Mode 2

Press and hold PARAM and switch the power on. The display will show patch name (see Fig. 3). Feeding an MIDI NOTE ON replaces a patch name character located at position assigned to the current module with the module name (A-F). On the NOTE OFF the name disappears, leaving the character position blank until the same module is assigned again.

Mode 3. ROM (Assigner Board) Version Identification/Rotary Key Assignment

Upon entering this mode, the display will show software version number in the assigner board ROM for 7 seconds. In this mode modules are assigned from A to F in cyclic fashion, one at a time, on repetition of NOTE ON and OFF at the same key number.

NOTE

Module board ROM version number cannot be disclosed with this test mode.

CAUTION

Rotary assignment is not engaged when MIDI function has been set to MONO mode. Set to POLY when making use of rotary feature. Also, rotary assignment will be disordered when more than one key number is applied simultaneously. To recover, turn the unit off and reenter this mode.

Entering Test Mode 3

Press and hold VALUE and switch the power on.

2. 発音モジュール表示モード

MKS-70が発音時、音源ブロックA又はB側のAからFのどのモジュールがアサインされているかを、Fig. 4で示したディスプレイ上の位置に、モジュールネーム(アルファベットA-F)で表示します。

本モード突入直後は通常使用のプレイモード時と同様にパッチネームがディスプレイに表示されています。以後同一ナンバーのノートオンオフ情報をくり返し受信するとFig. 4の様に、アサインされたモジュールのアルファベットが順々に点灯、消灯し、パッチネームの文字を消します。

モードへの入り方

PARAM ボタンを押しながら電源を入れる。

3. アサインボードROMバージョン確認、ロータリーアサインモード

本モードで電源投入後約7秒間ディスプレイにアサインボードROMのバージョンを表示します。また、それ以後のアサイン方式は*ロータリーになります。

注. ① ROMのバージョン表示はアサインボード部のROMのみであり、モジュールボード部のROMは一切関係しません。

② MIDIファンクションの設定がMONOモードである場合、ロータリーモードは働きません。したがってMIDIファンクションを必ずPOLYに設定した後、本モードに入ってください。

③ 複数の異なるキーナンバーの音が同時に発音した(和音のデータが送られてきた)場合以後、ロータリーアサインの順序は乱れてしまいます。復旧するためには、電源を一旦切り再び本モードを立ち上げて下さい。

*ロータリーアサインモード

任意の1つの音を繰り返し鳴らした(MIDIメッセージの同一ナンバーのノートオンオフ情報を繰り返し受信した)場合AからFまでの各モジュールを順番に発音させます。

モードへの入り方

VALUE ボタンを押しながら電源を入れる。

ADJUSTMENT

Before performing the following adjustments, read TEST MODES.

VCF

- Pressing [PARAM] and [VALUE], turn the power on. This procedure puts the unit into the combination of test modes 2 and 3.
- Press [ENTER] and [SHIFT] simultaneously and the associated LEDs will light. The number buttons [1] through [8] will serve as individual natural key, respectively. Two modules, one each in voice blocks A and B are assigned in sequence to each key pressing. Assigned modules are identified on the display. Wait at least for 5 minutes before going to the next step.
- Without using external controller (leave PROGRAMMER socket disengaged), edit tone parameter values to Fig. 5.
- Connect the oscilloscope to OUTPUT A L (MONO) and an open-circuit plug to B R (MONO).
- Press [◀] button twice. This will lower buttons [1]-[8] by 2 octaves in pitch.
- Press the button [6] and verify that it produces A4 (A above middle C).
- Pressing button [6], determine the currently assigned modules on the display: Adjust trimpot on that module on module board A for a maximum level.
- In the same manner adjust the remaining modules on the module board A.
- Move the oscilloscope to OUTPUT B R (MONO) and the plug to OUTPUT A L (MONO).
- Repeat steps 7 and 8 for the modules on module board B.

NUMBER	PARAMETER	VALUE
11	DCO 1 RANG	8'
12	DCO 1 WF	SQR
13	DCO 1 TUNE	00
14	DCO 1 LFO	00
15	DCO 1 ENV	00
41	MIX DCO 1	99
42	MIX DCO 2	00
43	MIX ENV	00
52	VCF FREQ	54
53	VCF RES	99
54	VCF LFO	00
55	VCF ENV	00
56	VCF KEY	00
61	VCA LEVEL	70
62	VCA MODE	GATE
64	CHORUS	OFF

Fig. 5

調整仕様

VCF

- [PARAM], [VALUE] の両ボタンを押しながら電源を入れる。(テストモード2, 3のコンビネーションを立ち上げる)
- [ENTER], [SHIFT] の両ボタンを同時に押し、両ボタンのLEDを点灯させる。
[1] から [8] のナンバーボタンが簡易的なキーボードの役割を果たすようになります。この内1つのボタンを押すたびに、音源ブロックA, B両方のブロック内の各1モジュールずつが、順々にアサインされ(ディスプレイにも表示され)ます。
通電5分以上経過してから次のステップへ進んで下さい。
- Fig. 5の音色パラメータを本体のみで、音源ブロックA, B両方について設定する。
〔注意: PROGRAMMER端子には何も接続しない事〕
- OUTPUTジャックA L (MONO)にオシロスコープをB R (MONO)にダミージャック(オープン)を接続する。
- [◀] のボタンを2回押す。
([1] から [8] のナンバーボタンの音域を2オクターブ下げる)
- [6] のボタンを押すと、A4の音が発音する事を確認する。
- [6] のボタンを押し、その時モジュールボードA側のアサインされている(ディスプレイに表示)モジュールの半固定VRを調整し、出力波形が最大になるようにする。
- 残りの5つのモジュールについても⑦をくり返し同様に行なう。
- OUTPUTジャックの接続を下記の様に入れ換える。
A L (MONO) → ダミージャック
B R (MONO) → オシロスコープ
- 音源ブロックB側の各モジュールも音源ブロックA側と同様に調整する。

1 2 3 4 5 6 7 8 9 10 11 12 13 14 15 16 17 18 19 20 21 22 23 24 25 26 27 28 29 30 31 32 33 34 35 36 37 38 39

CIRCUIT DIAGRAM

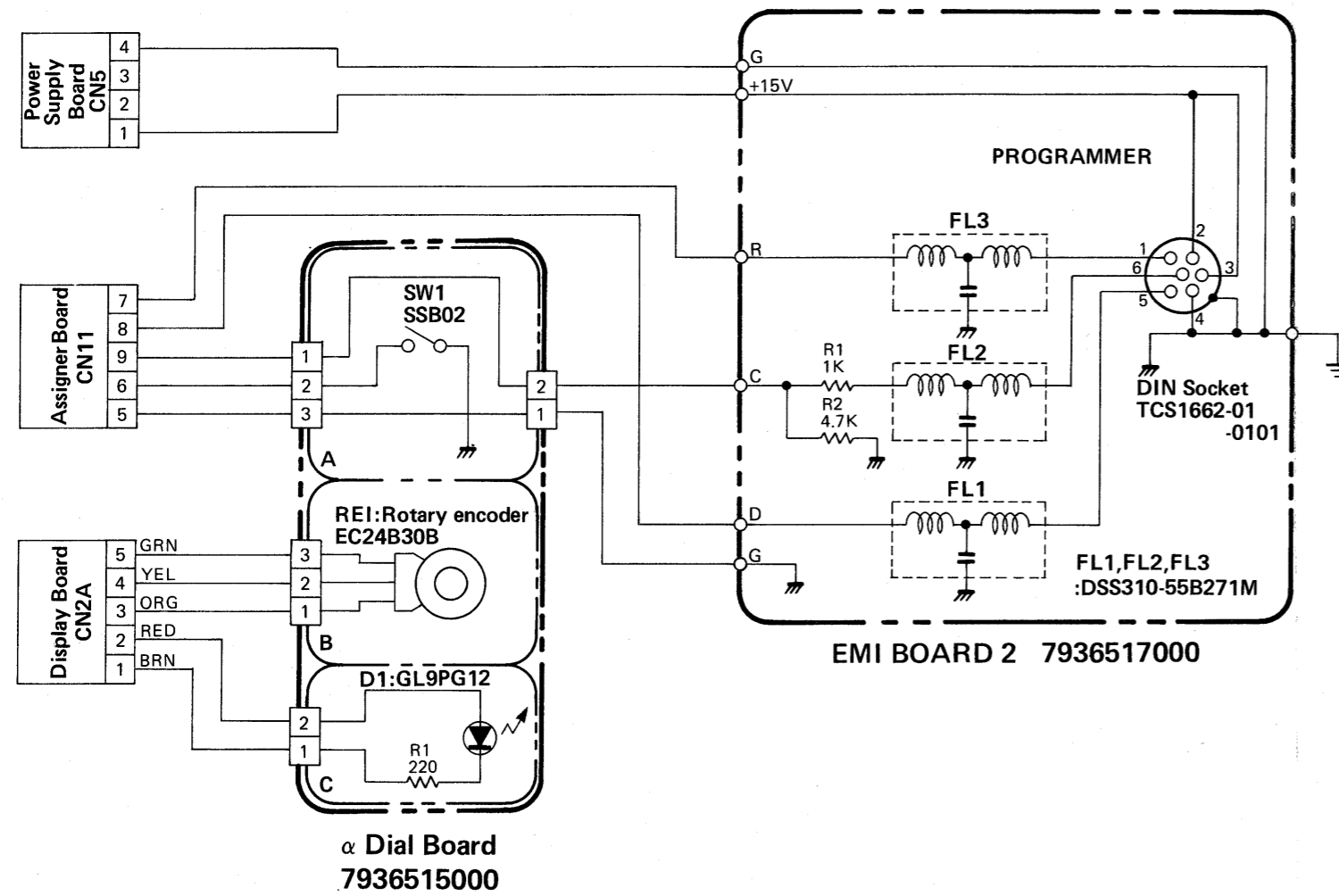

ASSIGNER BOARD
ASSY 7616510000
 (pcb 2292339395)

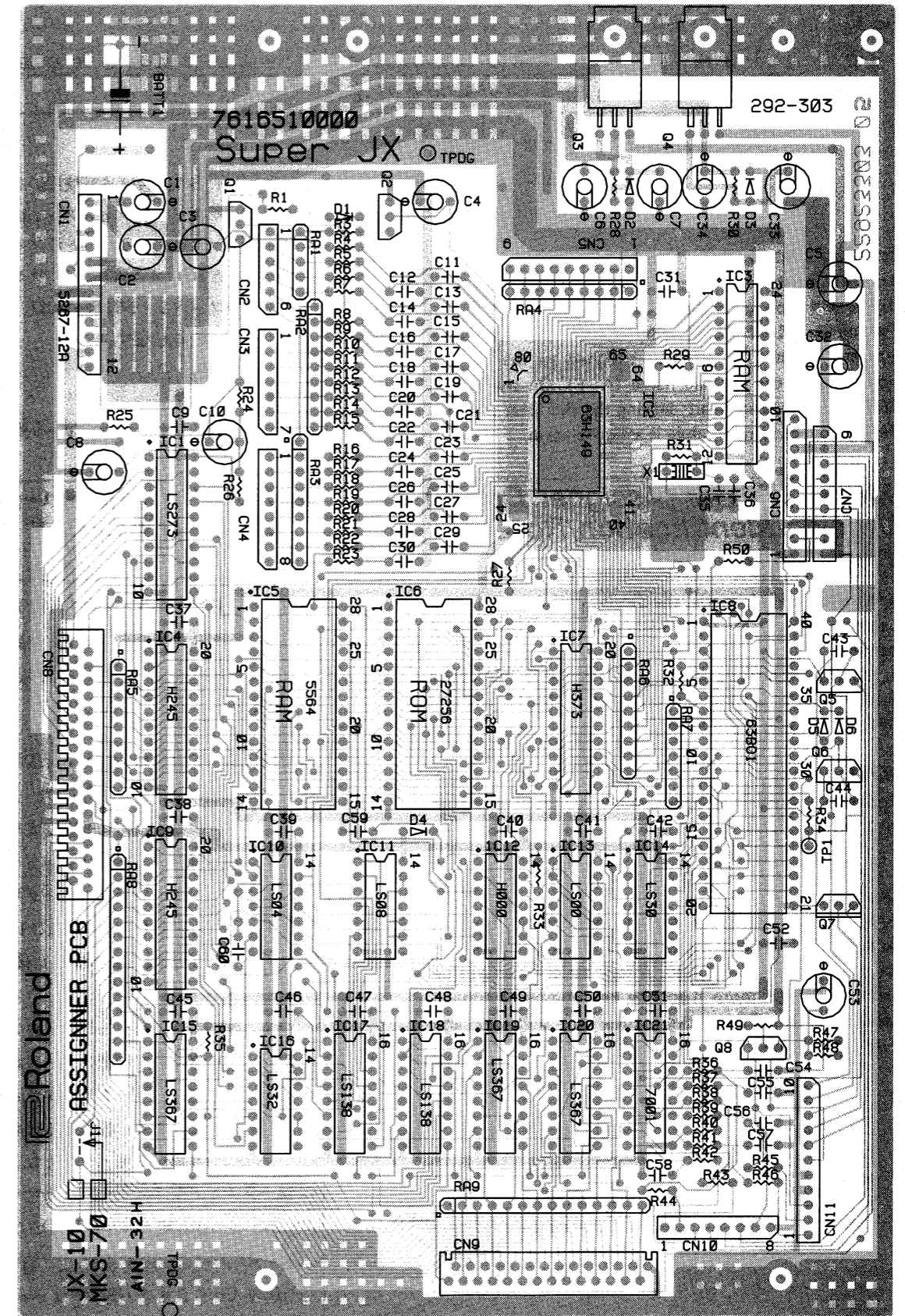

α DIAL BOARD
ASSY 7936515000
 (pcb 2292339100)

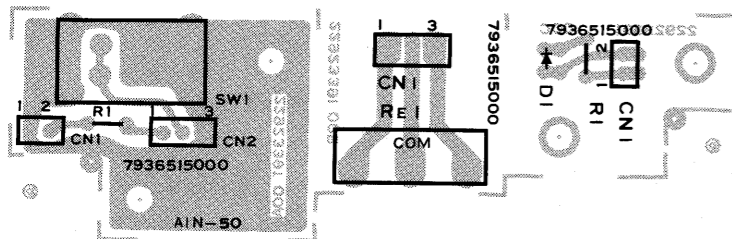

View from parts side

EMI BOARD (2)
ASSY 7936510000
 (pcb 2292342900)

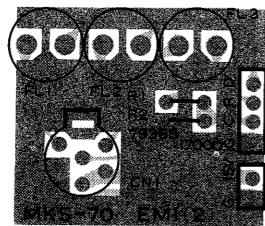

View from parts side

ADVARSEL!

Lithiumbatteri. Eksplosionsfare.
 Udskiftning må kun foretages af en sagkyndig,
 og som beskrevet i servicemanual.

Lithium batteri må kun udskiftes med samme type
 og fabrikat.

ADVARSEL!

Lithiumbatteri. Fare for eksplotion.
 Må bare skiftes af kvalifisert tekniker som
 beskrevet i servicemanualen.

Lithium batteri må kun utskiftes med samme type
 og fabrikat.

WARNING!

Lithiumbatteri. Explosionsrisk.
 Får endast bytas av behörig servicetekniker.
 Se instruktioner i servicemanualen.

Lithium batteri för endast ersättes med samme typ
 och fabrikat.

VAROITUS!

Lithiumparisto. Rajähäysvaara.
 Pariston saa vaihtaa ainoastaan
 alan ammottimies.

Kun vaihat lithium pariston KÄYTÄ saman valmista-
 jan samaa tyyppiä.

View from parts side

1 2 3 4 5 6 7 8 9 10 11 12 13 14 15 16 17 18 19 20 21 22 23 24 25 26 27 28 29 30 31 32 33 34 35 36 37 38 39 40 41 42 43 44 45 46 47 48 49

CIRCUIT DIAGRAM

A
B
C
D
E
F
G
H
I
J
K
L
M
N
O
P
Q
R
S
T
U
V
W
X
Y
Z

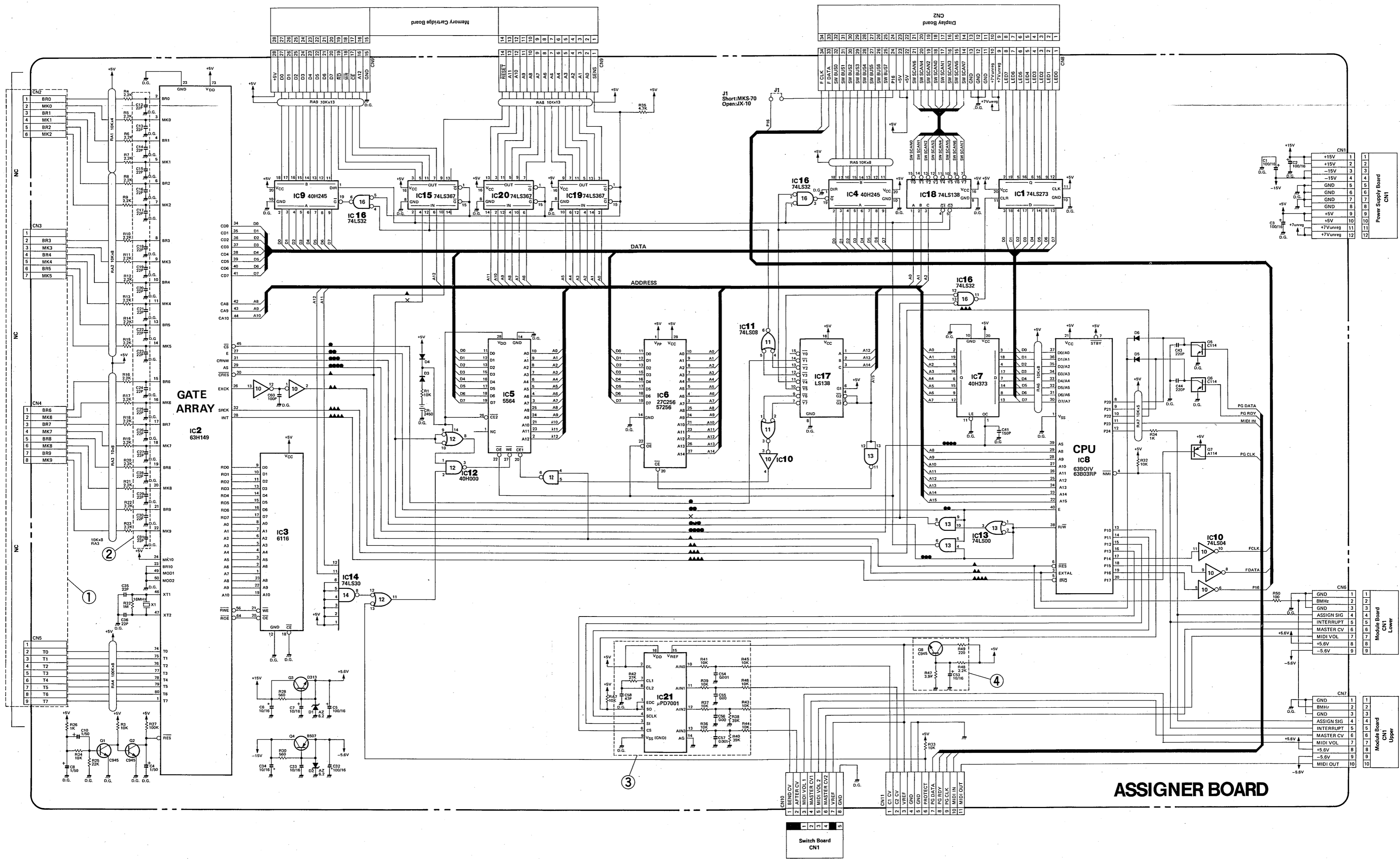

① through ④:
Not installed on the products with SN741300-UP.

注意:
SN741300からの製品では ①-④の部品が削除されています。

1 2 3 4 5 6 7 8 9 10 11 12 13 14 15 16 17 18 19 20 21 22 23 24 25 26 27 28 29 30 31 32 33 34 35 36 37 38 39 40 41 42 43 44 45 46 47

IC DATA

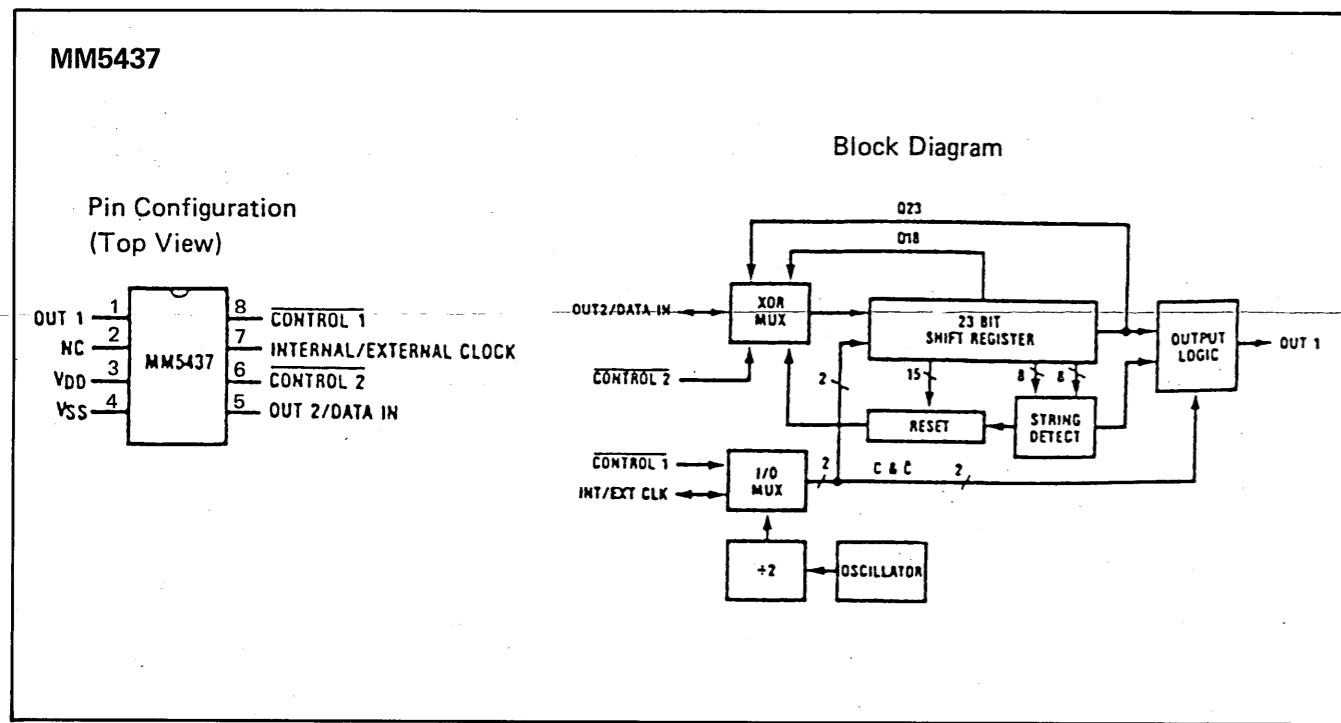

CARTRIDGE BOARD
 ASSY 7616505000
 (pcb 2292312603)

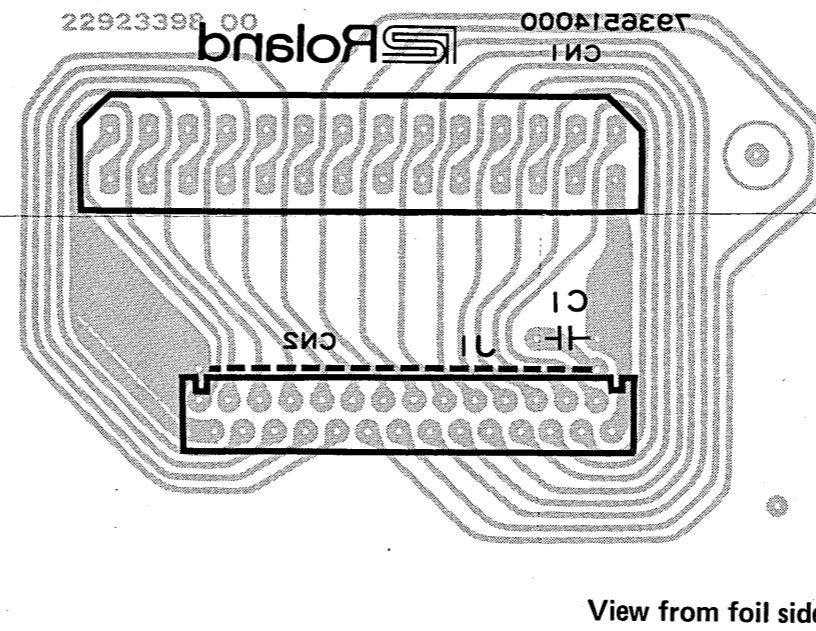

CIRCUIT DIAGRAM

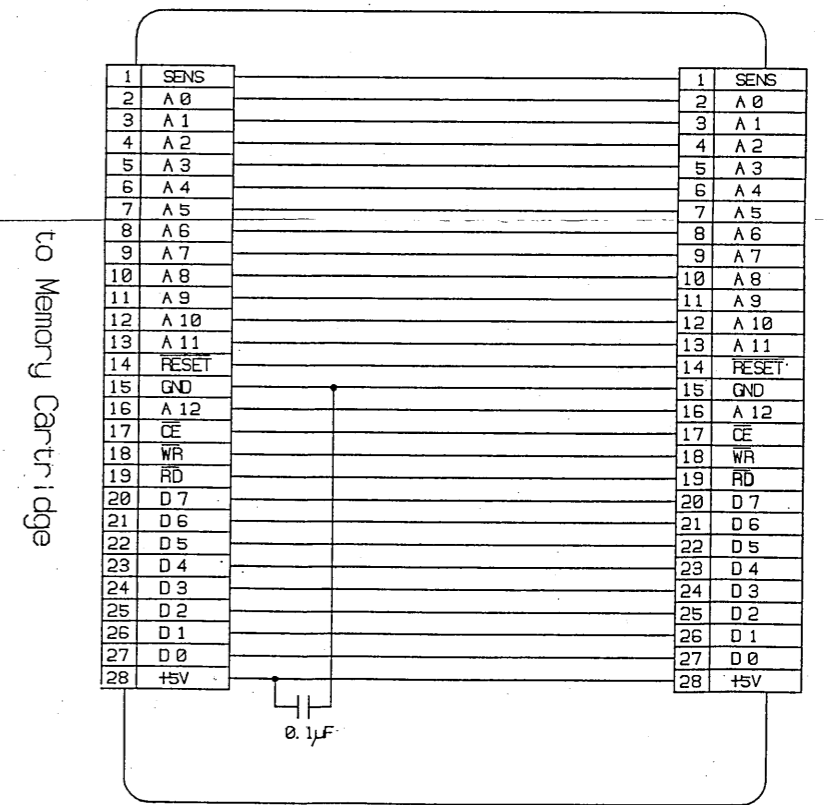

MODULE BOARD
 ASSY 7616507000
 (pcb 2292339294)

Common to Modules A and B.

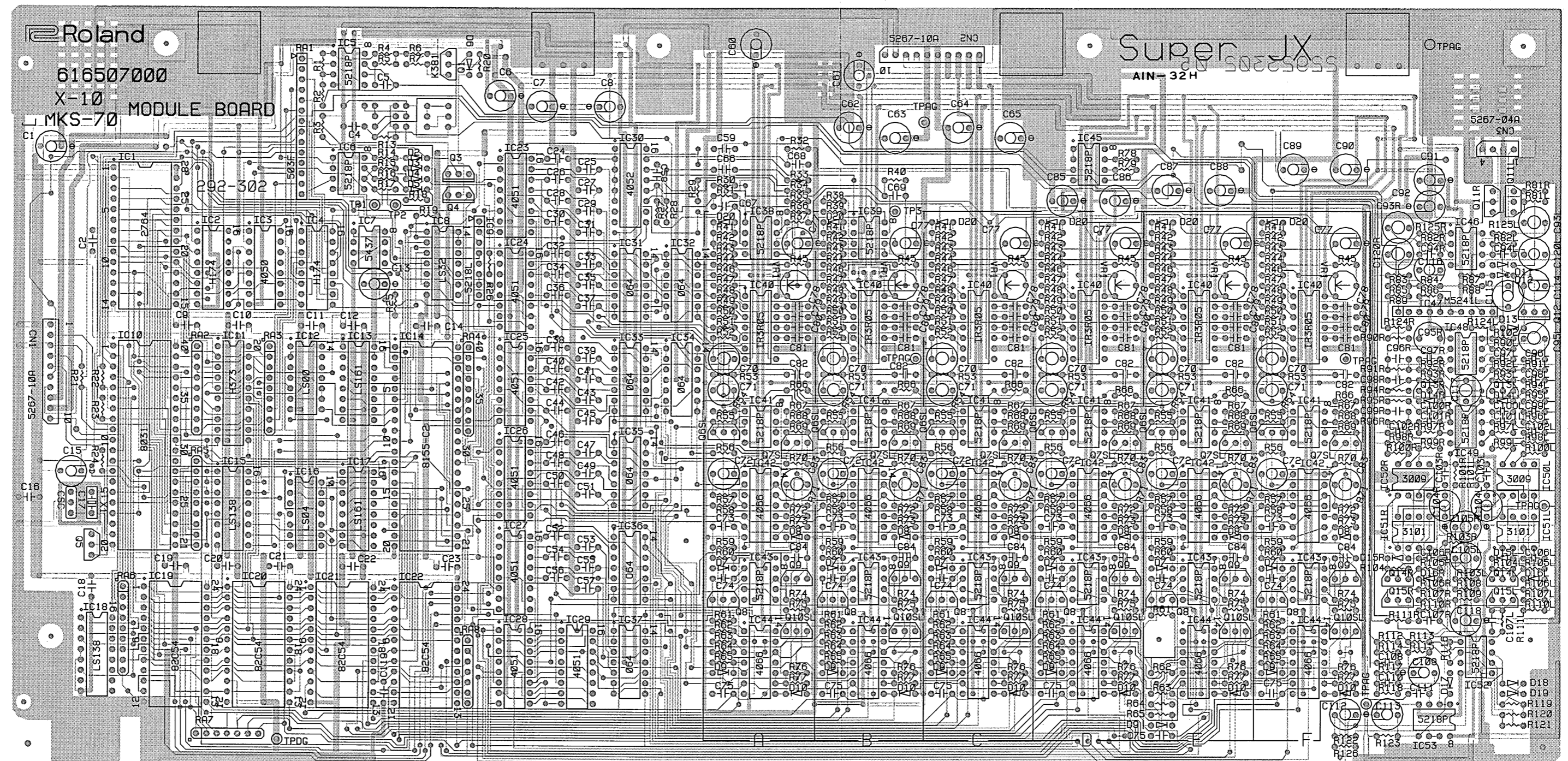

A
B
C
D
E
F
G
H
I
J
K
L
M
N
O
P
Q
R
S
T
U
V
W
X
Y
Z

to JX-10 Ass'gner Board

to Memory Cartridge

1 2 3 4 5 6 7 8 9 10 11 12 13 14 15 16 17 18 19 20 21 22 23 24 25 26 27 28 29 30 31 32 33 34 35 36 37 38 39 40 41 42 43 44 45 46 47 48 49 50 51 52 53 54 55 56 57 58 59 60 61 62 63 64

CIRCUIT DIAGRAM

A B C D E F G H I J K L M N O P Q R S T U

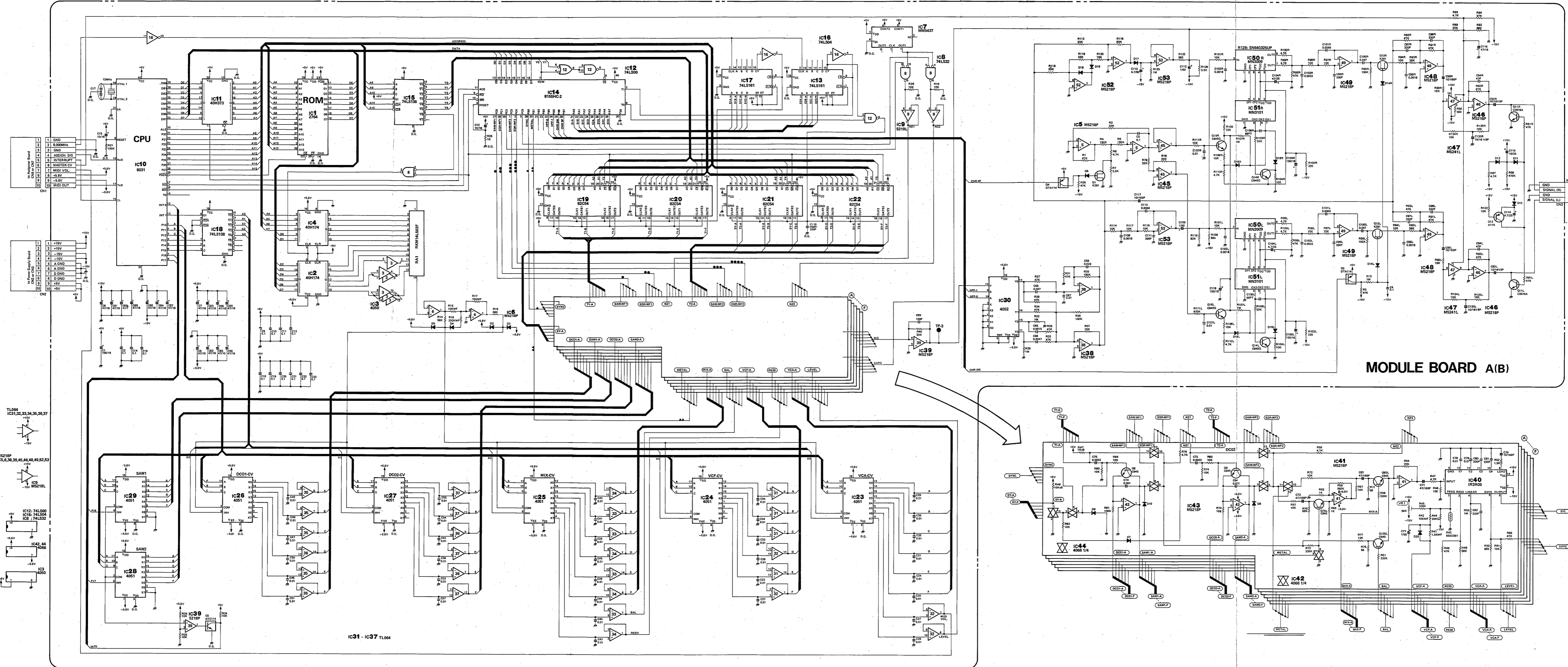

MODULE BOARD A(B)

1 2 3 4 5 6 7 8 9 10 11 12 13 14 15 16 17 18 19 20 21 22 23 24 25 26 27 28 29 30 31 32 33 34 35 36 37 38 39 40 41 42 43 44 45 46 47 48 49 50 51 52 53 54 55 56 57 58 59 60 61 62 63 64 65

CIRCUIT DIAGRAM

A
B
C
D
E
F
G
H
I
J
K
L
M
N
O
P
Q
R
S
T
U
V

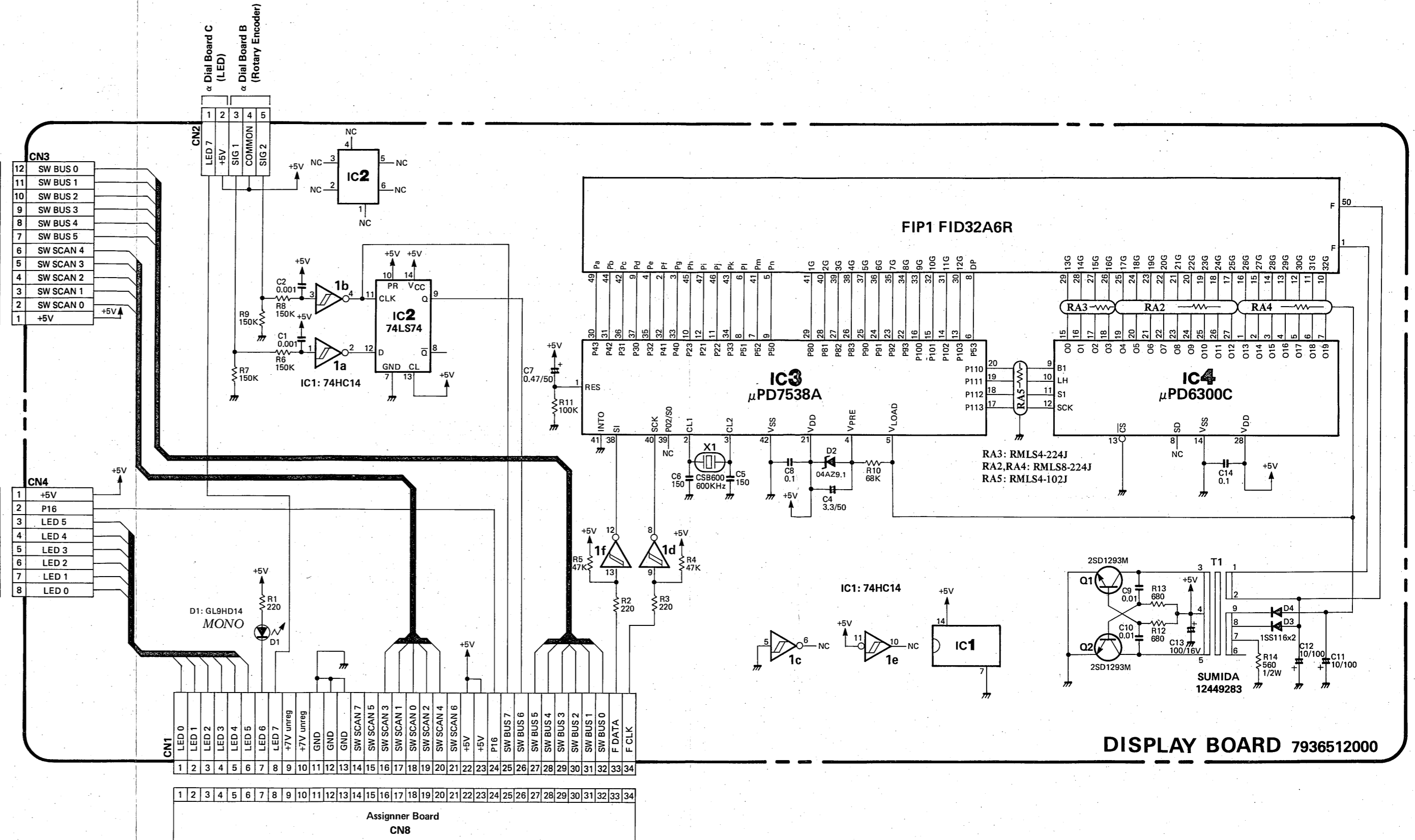
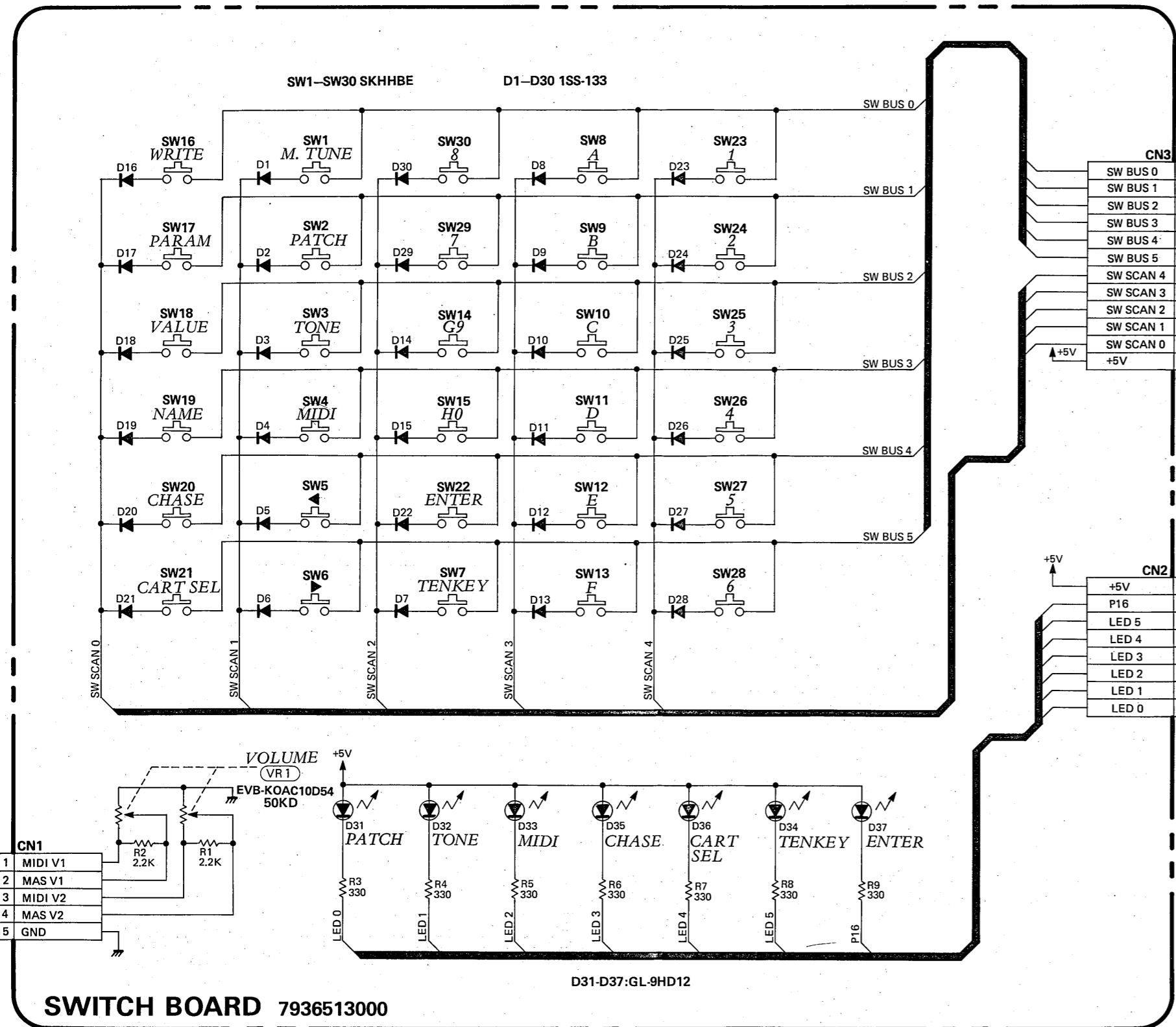

1 2 3 4 5 6 7 8 9 10 11 12 13 14 15 16 17 18 19 20 21 22 23 24 25 26 27 28 29 30 31 32 33 34 35 36 37 38

A
B
C
D
E
F
G
H
I
J
K
L
M
N
O
P
Q
R
S
T
U

DISPLAY BOARD

ASSY 7936512000

(pcb 2292338500)

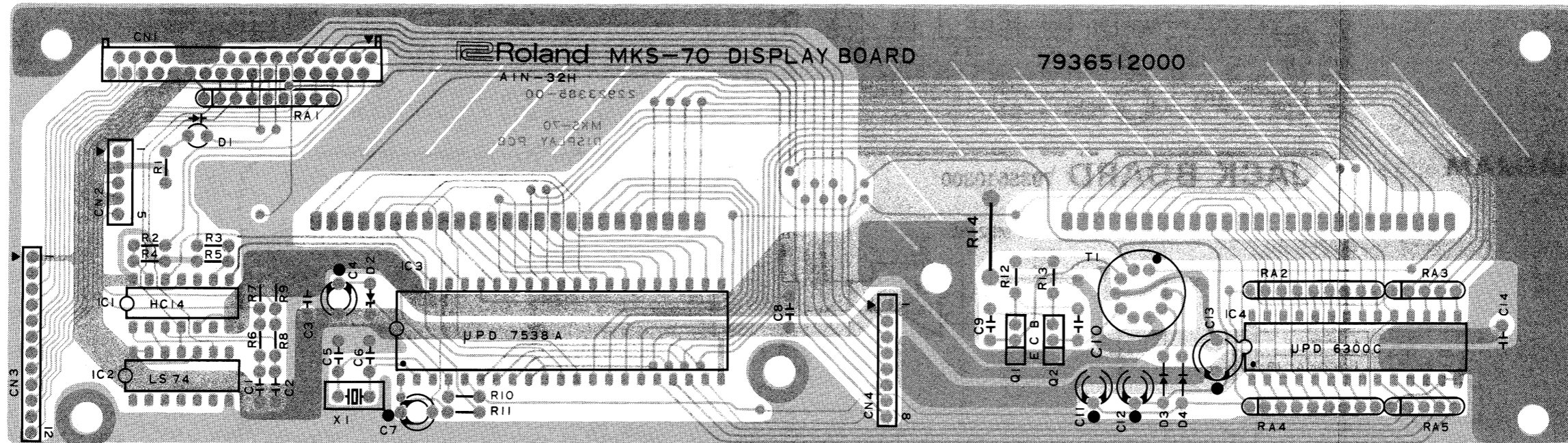

Viewing at CPU

SWITCH BOARD

ASSY 7936513000

(pcb 2292338300)

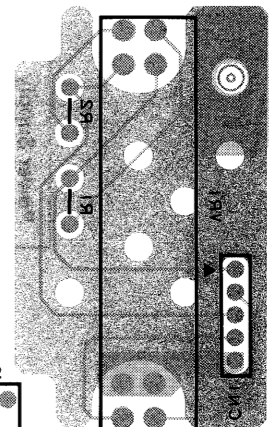
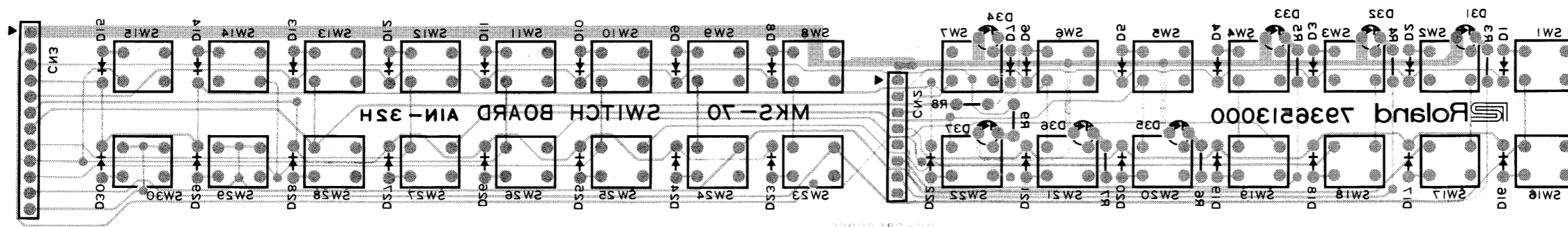

View from foil side

1 2 3 4 5 6 7 8 9 10 11 12 13 14 15 16 17 18 19 20 21 22 23 24 25 26 27 28 29 30 31 32 33 34 35 36 37 38 39

A
B
C
D
E
F
G
H
I
J
K
L
M
N
O
P
Q
R
S
T
U
V

JACK BOARD
ASSY 7936510000
 (pcb 2292338400)

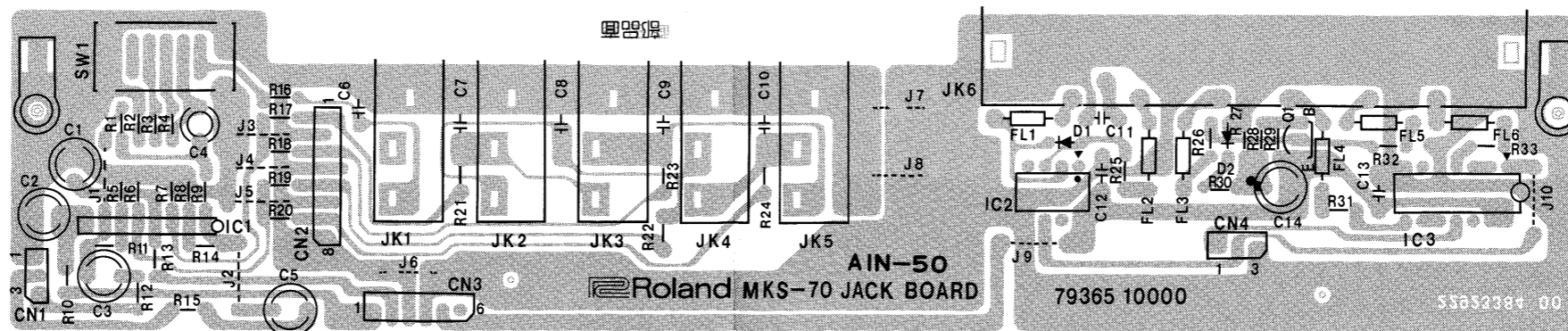

View from parts side

CIRCUIT DIAGRAM

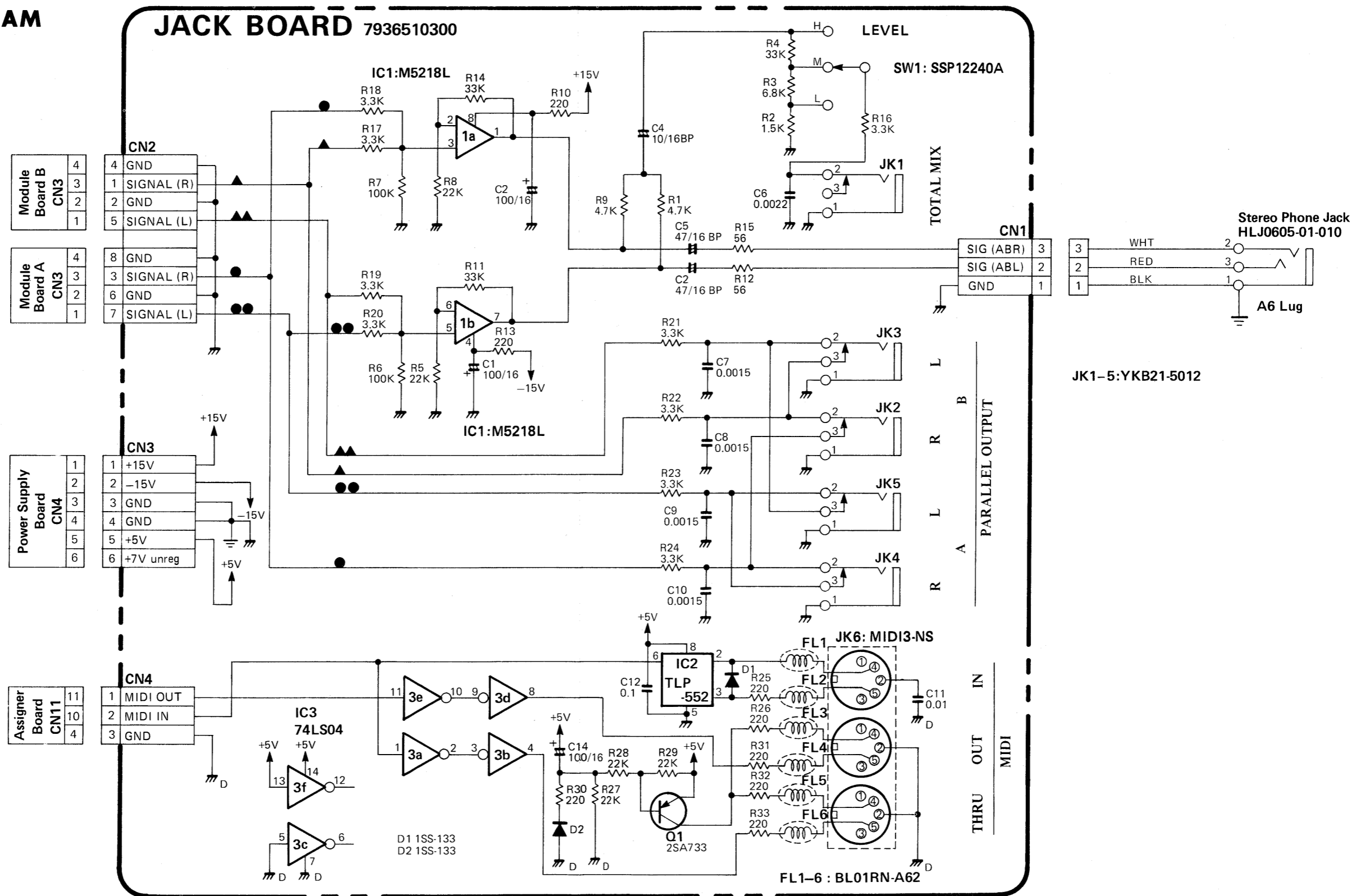

1 2 3 4 5 6 7 8 9 10 11 12 13 14 15 16 17 18 19 20 21 22 23 24 25 26 27 28 29 30 31 32 33 34 35 36 37 38 39

A B C D E F G H I J K L M N O P Q R S T U V

FILTER BOARD ASSY 7936506200 (pcb 2292341900) (100/117V)
ASSY 7936506400 (pcb 2292341900) (220V)
ASSY 7936506500 (pcb 2292341900) (240V)

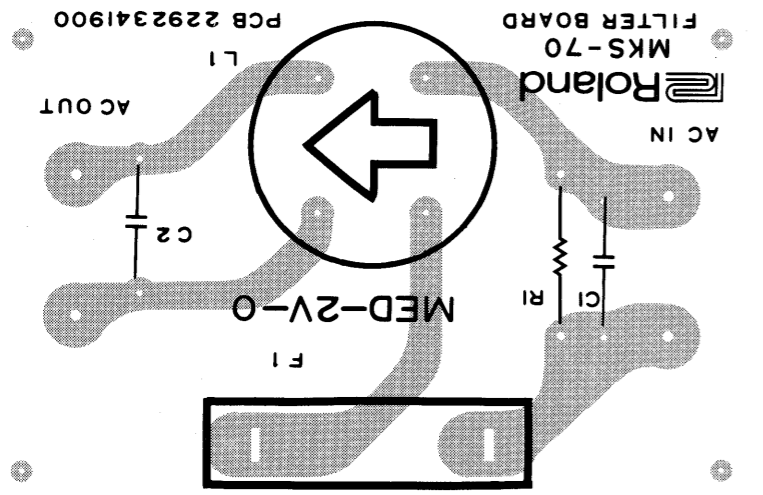

View from parts side

POWER SUPPLY BOARD

ASSY 7936507000
(pcb 2292329900)

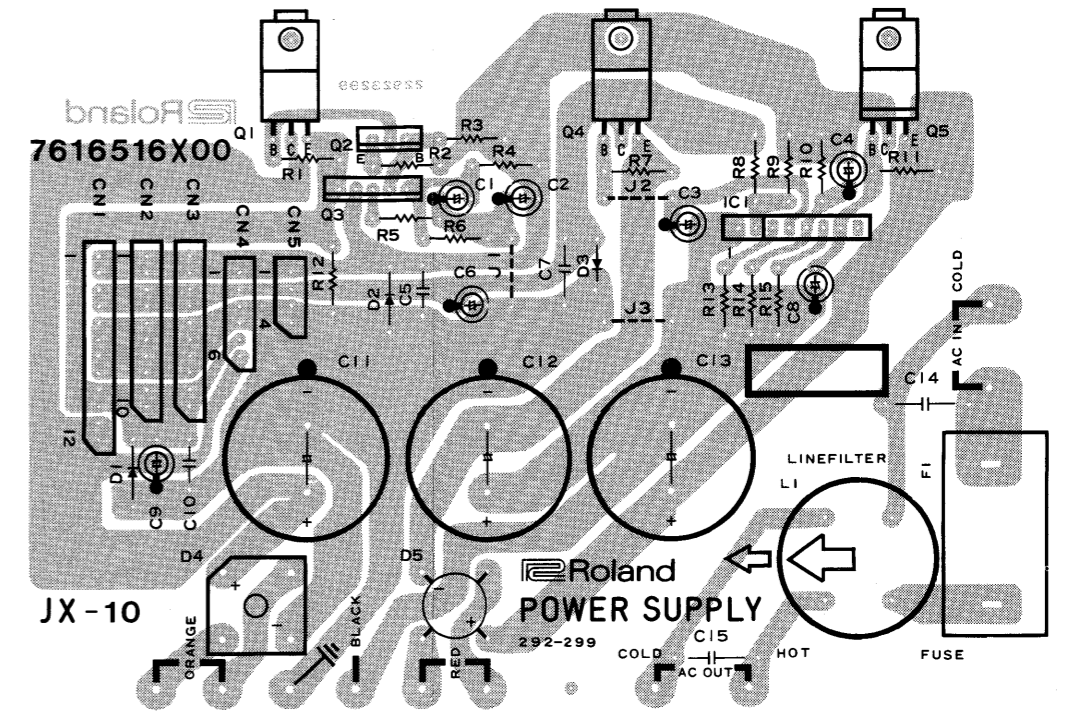

View from parts side

EMI BOARD (1)

ASSY 7936518000
(pcb 2292342800)

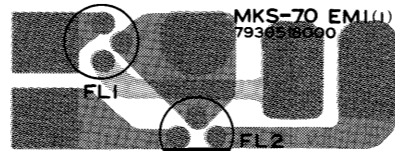

View from parts side

CIRCUIT DIAGRAM

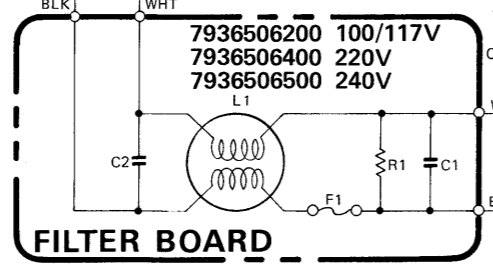
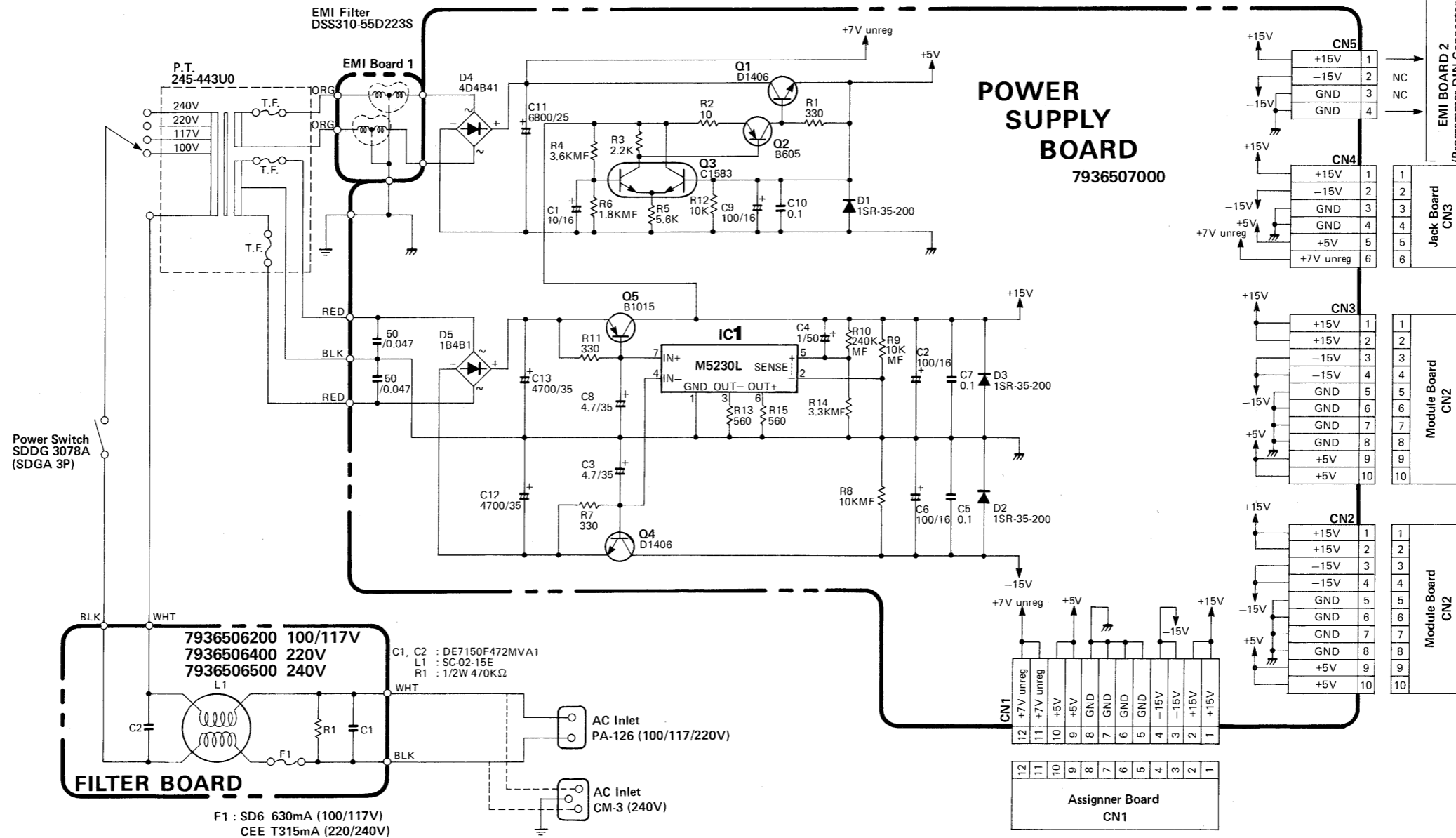

F1 : SD6 630mA (100/117V)
CEE T315mA (220/240V)

IC DATA

μPD7538A

Pin Configuration
Top View

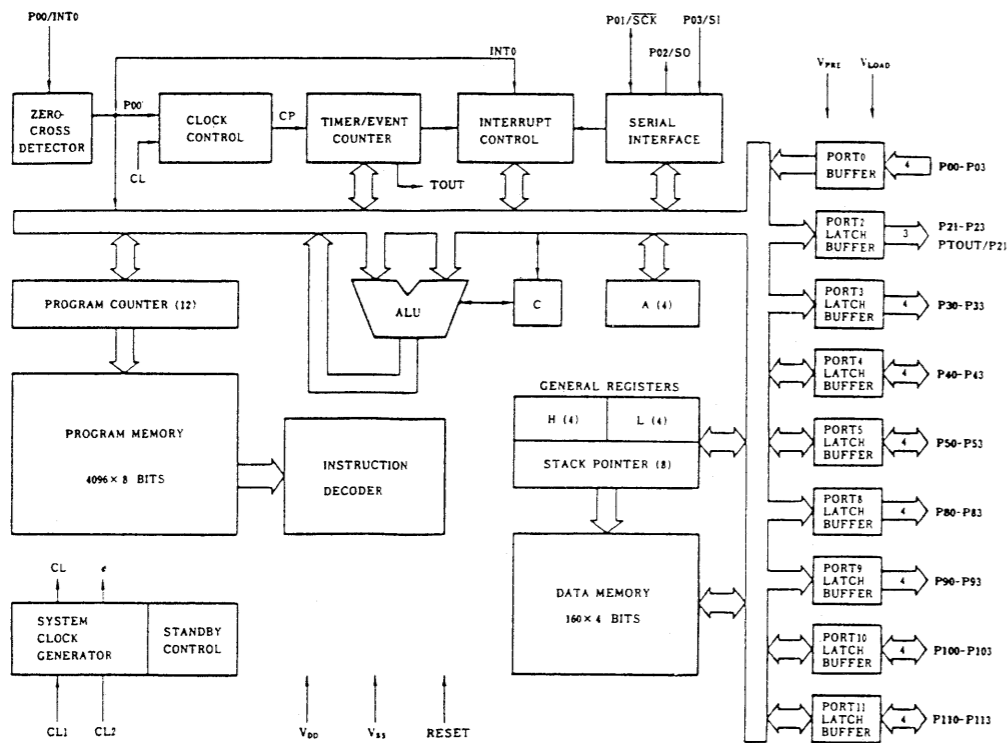
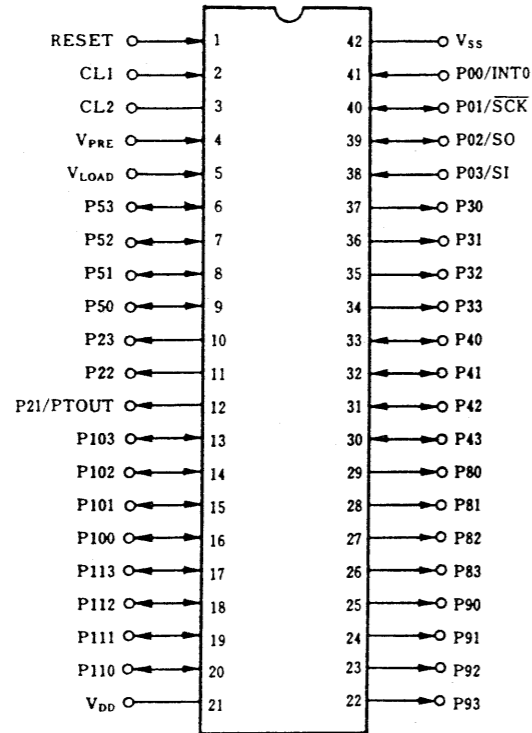

MB63H149

Pin Assignment

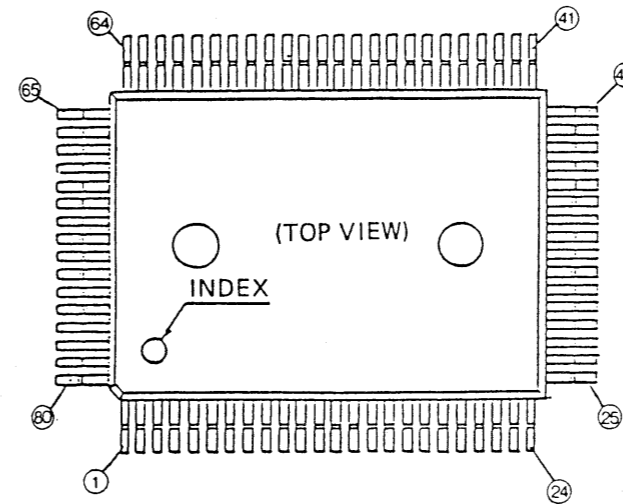

Pin no.	I/O	Pin name	Pin no.	I/O	Pin name	Pin no.	I/O	Pin name	Pin no.	I/O	Pin name
1	O	T7	21	I	BR9	41	I/O	CD7	61	O	RA1
2	I	BR0	22	I	MK9	42	I	CA8	62	O	RA10
3	I	MK0	23	I	BR10	43	I	CA9	63	O	RA2
4	I	BR1	24	I	MK10	44	I	CA10	64	I/O	ROE
5	I	MK1	25	I	RES	45	I	CS	65	O	RA3
6	I	BR2	26	I/O	EXCK	46	I	XT1	66	O	RWE
7	I	MK2	27	I	E	47	O	XT2	67	O	RA4
8	I	BR3	28	O	INT	48	O	ASEL	68	O	RA9
9	I	MK3	29	I	AS	49	I	MOD1	69	O	RA5
10	I	BR4	30	O	CRSW	50	I	MOD2	70	O	RA8
11	I	MK4	31	I	CRNW	51	I/O	RD3	71	O	RA6
12	-	VSS	32	O	SRCK	52	-	VSS	72	O	RA7
13	I	BR5	33	-	VDD	53	I/O	RD4	73	-	VDD
14	I	MK5	34	I/O	CD0	54	I/O	RD2	74	O	T0
15	I	BR6	35	I/O	CD1	55	I/O	RD5	75	O	T1
16	I	MK6	36	I/O	CD2	56	I/O	RD1	76	O	T2
17	I	BR7	37	I/O	CD3	57	I/O	RD6	77	O	T3
18	I	MK7	38	I/O	CD4	58	I/O	RDO	78	O	T4
19	I	BR8	39	I/O	CD5	59	I/O	RD7	79	O	T5
20	I	MK8	40	I/O	CD6	60	O	RA0	80	O	T6

μPD8155HC-2

Pin Configuration
(Top View)

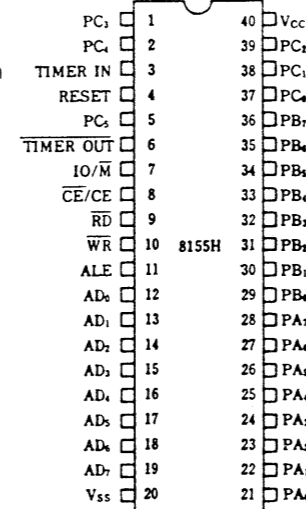

Block Diagram

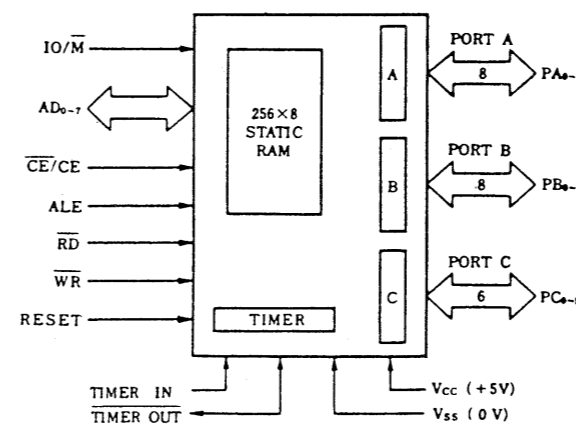

HD63B03RP

Pin Configuration
(Top View)

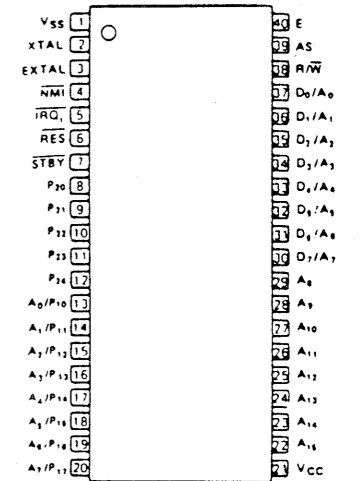

Block Diagram

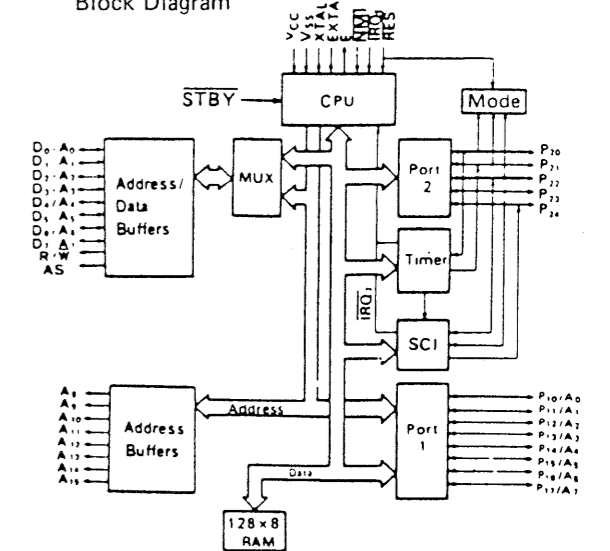

MIDI IMPLEMENTATION

[12-voice Sound module]
Model MKS-70

Date : Sep, 6 1986
MIDI Implementation Chart Version : 1.00

version 1.0
Sep, 6 1986

Function ...	Transmitted	Recognized	Remarks
Basic Default	x	1 - 16	memorized
Channel Changed	x	1 - 16	
Mode Default	x	Mode 3, Mode 4	memorized
Mode Messages	x	POLY, MONO	
Mode Altered	*****	x	
Note Number	x	0 - 127	
Note True voice	*****	21 - 108	
Velocity Note ON	x	o v = 1 - 127	
Note OFF	x	x	
After Key's	x	x	
Touch Ch's	x	*	
Pitch Bender	x	o 2/3/4/7/12 semi 8bits reso.	
Control 1	x	o	Modulation
Control 5	x	o	Portamento time
Control 7	x	*	Volume
Control 64	x	o	Hold1
Control 65	x	o	Portamento Switch
Prog Change True #	* 0-99(0-127) 0-99(0-127)	* 0-99(0-127) 0-99(0-127)	**
System Exclusive	*	*	
System Song Pos	x	x	
System Song Sel	x	x	
Common Tune	x	x	
System Clock	x	x	
Real Time Commands	x	x	
Aux Local ON/OFF	x	x	
Aux All Notes OFF	x	o (123-127)	
Mes- Active Sense	x	x	
sages Reset	x	x	
Notes	* Can be set to o or x manually, and memorized. ** As tone # :0-99(100-127 ignored if received.) As patch # :0-127 See implementation notes for details.		

Mode 1 : OMNI ON, POLY Mode 2 : OMNI ON, MONO o : Yes
Mode 3 : OMNI OFF, POLY Mode 4 : OMNI OFF, MONO x : No

1. TRANSMITTED DATA

Status	Second	Third	Description
1100 nnnn	Oppp pppp		Program Change ppppppp = 0 - 127 (0 - 99)

Notes : Program Change (TONE #) are transmitted on CHANNEL A and/or channel B according to KEY MODE.
Program Change (PATCH #) are transmitted on CONTROL CHANNEL

- a. On CHANNEL A OR CHANNEL B :
TONE # is Transmitted if the corresponding function switch is ON.
ppppppp = 0 - 99 : TONE No. 1 - 100
- b. On CONTROL CHANNEL :
PATCH # is Transmitted if the corresponding function switch is ON.
ppppppp = 0 - 63 : Internal Memory PATCH A1 - H8
64 - 127 : Cartridge Memory PATCH A1 - H8

2. RECOGNIZED RECEIVE DATA

Status	Second	Third	Description
1000 nnnn	Okkk kkkk	0vvv vvvv	Note OFF, velocity ignored
1001 nnnn	Okkk kkkk	0000 0000	Note OFF kkkkkkk = 0 - 127 (21 - 108) *1
1001 nnnn	Okkk kkkk	0vvv vvvv	Note ON kkkkkkk = 0 - 127 (21 - 108) *1 vvvvvvv = 1 - 127
1011 nnnn	0000 0001	0vvv vvvv	Modulation vvvvvvv = 0 - 127
1011 nnnn	0000 0101	0vvv vvvv	Portamento time vvvvvvv = 0 - 127
1011 nnnn	0000 0111	0vvv vvvv	Volume *2 vvvvvvv = 0 - 127
1011 nnnn	0100 0000	01xx xxxx	Hold 1 ON
1011 nnnn	0100 0000	00xx xxxx	Hold 2 OFF
1011 nnnn	0100 0001	01xx xxxx	Portamento ON
1011 nnnn	0100 0001	00xx xxxx	Portamento OFF
1100 nnnn	Oppp pppp		Program Change ppppppp = 0 - 127 (0 - 99) *2,*3
1101 nnnn	0vvv vvvv		Channel After Touch vvvvvvv = 0 - 127 *2
1110 nnnn	0vvv vvvv	0vvv vvvv	Pitch Bender Change *2
1011 nnnn	0111 1110	000m mmmm	Mono ON *2
1011 nnnn	0111 1111	0000 0000	Poly ON *2
1011 nnnn	0111 1011	0000 0000	ALL NOTES OFF

Notes : All messages except PATCH # (Program Change) are received from CHANNEL A and/or CHANNEL B according to KEY MODE.

*1 Note numbers outside of the range 21 - 108 are transposed to the nearest octave inside this range.

*2 Received if the corresponding function switch is ON.

*3 a. ON CHANNEL A OR CHANNEL B
 Received as TONE # if the corresponding function switch is ON.
 ppppppp = 0 - 99 : TONE No. 1 - 100
 b. ON CONTROL CHANNEL :
 Received as PATCH # if the corresponding function switch is ON.
 ppppppp = 0 - 63 : Internal Memory PATCH A1 - H8
 64 -127 : Cartridge Memory PATCH A1 - H8

3. TRANSMITTED EXCLUSIVE MESSAGES

3.1 When the 'Patch Bank' or 'Patch Number' is changed, the following exclusive messages (3.1.1 PGR and 3.1.2 APR) are sent in sequence.

3.1.1 Program Number (PGR)

Byte	Description
a 1111 0000	Exclusive status
b 0100 0001	Roland ID #
c 0011 0100	Operation code = PGR (program number)
d 0000 nnnn	Unit # = control channel, nnnn = 0 - 15 where nnnn + 1 = channel #
e 0010 0100	Format type (JX-10)
f 0011 0000	Level 2 Patch
g 0000 0001	Group #
h 0000 0000	PG# Indicates the patch number
i 00pp pppp	Patch number
j 0000 0000	NOP
k 1111 0111	End of System Exclusive

3.1.2 All Patch Parameters (APR)

Byte	Description
a 1111 0000	Exclusive status
b 0100 0001	Roland ID #
c 0011 0101	Operation code = APR (all parameters)
d 0000 nnnn	Unit # = control channel, nnnn = 0 - 15 where nnnn + 1 = channel #
e 0010 0100	Format type (JX-10)
f 0011 0000	Level 2 Patch
g 0000 0001	Group #
h 0vvv vvvv	Value (0 - 127)
:	In sequence (51 byte total)
i 1111 0111	End of System Exclusive

3.2 Individual Patch Parameter (IPR)
 When the Patch Memory Factor is changed.

Byte	Description
a 1111 0000	Exclusive status
b 0100 0001	Roland ID #
c 0011 0110	Operation code = IPR (individual parameter)

d 0000 nnnn Unit # = control channel, nnnn = 0 - 15
 where nnnn + 1 = channel #
 e 0010 0100 Format type (JX-10)
 f 0011 0000 Level 2 Patch
 g 0000 0001 Group #
 h 00pp pppp Parameter # (0 - 51)
 i 0vvv vvvv Value (0 - 127)
 : h and i (repeatedly)
 j 1111 0111 End of System Exclusive

Notes :

parameter #	Function	Value
0-17	PATCH NAME 1..18	In ASCII
18	U/L BALANCE	0 - 127
19	DUAL DETUNE	0 - 127
20	UPPER SPLIT POINT	21 - 108
21	LOWER SPLIT POINT	21 - 108
22	PORTAMENTO TIME	0 - 127
23	BEND RANGE 0aaaaaaa	0, 32, 64, 96
52	BEND RANGE 0bbbbbbb	0, 1
	BEND RANGE = bbbbbbbbaaaaaa	0 = 2 Semi Tones 32 = 3 Semi Tones 64 = 4 Semi Tones 96 = 7 Semi Tones 128 = 12 Semi Tones 160 = 12 Semi Tones 192 = 12 Semi Tones 224 = 12 Semi Tones
24	KEY MODE 000000aa	0 - 3
51	KEY MODE 000000bb	0 - 2
	KEY MODE = bbaa	0 = DUAL 1 = SPLIT 2 = A WHOLE 3 = B WHOLE 4 = X - FADE 8 = T - VOICE
25	TOTAL VOLUME	0 - 127
26	AFTER TOUCH VIBRATO	0 - 127
27	AFTER TOUCH BRILLIANCE	0 - 127
28	AFTER TOUCH VOLUME	0 - 127
29	UPPER TONE NUMBER	0 - 99
30	UPPER CHROMATIC SHIFT	0 - 24 = 0 - (+24) semi tones 104 - 127 = (-24) - (-1) semi tones
31	UPPER KEY ASSIGN	0 = Poly-1 1 = Unison-1 2 = Mono-1 4 = Poly-2 5 = Unison-2 6 = Mono-2
32	UPPER UNISON DETUNE	0 - 127
33	UPPER HOLD	0 = OFF 1 = ON
34	UPPER LFO MOD DEPTH	0 - 127
35	UPPER PORTAMENTO	0 = OFF 1 = ON
36	UPPER BENDER	0 = OFF 1 = ON
37	Undefined	
38	LOWER TONE NUMBER	0 - 99
39	LOWER CHROMATIC SHIFT	0 - 24 = 0 - (+24) semi tones 104 - 127 = (-24) - (-1) semi tones

40 LOWER KEY ASSIGN	0 = Poly-1
	1 = Unison-1
	2 = Mono-1
	4 = Poly-2
	5 = Unison-2
	6 = Mono-2
41 LOWER UNISON DETUNE	0 - 127
42 LOWER HOLD	0 = OFF
	1 = ON
43 LOWER LFO MOD DEPTH	0 - 127
44 LOWER PORTAMENTO	0 = OFF
	1 = ON
45 LOWER BENDER	0 = OFF
	1 = ON
46 Undefined	
47 CHASE LEVEL	0 - 127
48 CHASE MODE	0 = A-B
	1 = A-B-B-
	2 = A-B-A-
49 CHASE TIME	1 - 127
50 CHASE PLAY	0 = OFF
	1 = ON

3.3 When the 'Tone Number' is changed, the following exclusive messages (3.3.1 PGR and 3.3.2 APR) are sent in sequence.

3.3.1 Program Number (PGR)

Byte	Description
a 1111 0000	Exclusive status
b 0100 0001	Roland ID #
c 0011 0100	Operation code = PGR (program number)
d 0000 nnnn	Unit # = control channel, nnnn = 0 - 15 where nnnn + 1 = channel #
e 0010 0100	Format type (JX-10)
f 0010 0000	Level 1 Tone
g 0000 00gg	Group # gg = 01 Tone A gg = 10 Tone B
h 0000 0000	PG# indicates the tone number
i 0ttt tttt	Tone number
J 0000 0000	NOP
k 1111 0111	End of System Exclusive

3.3.2 All Tone Parameters (APR)

Byte	Description
a 1111 0000	Exclusive status
b 0100 0001	Roland ID #
c 0011 0101	Operation code = APR (all parameters)
d 0000 nnnn	Unit # = control channel, nnnn = 0 - 15 where nnnn + 1 = channel #
e 0010 0100	Format type (JX-10)
f 0010 0000	Level # = 1
g 0000 00gg	Group # gg = 01 Tone A gg = 10 Tone B
h 0vvv vvvv	Value (0 - 127)
:	In sequence (59 byte total)
i 1111 0111	End of System Exclusive

3.4 Individual Tone Parameter (IPR)
When the Parameter is changed.

Byte	Description
a 1111 0000	Exclusive status
b 0100 0001	Roland ID #
c 0011 0110	Operation code = IPR (individual parameter)
d 0000 nnnn	Unit # = control channel, nnnn = 0 - 15 where nnnn + 1 = channel #
e 0010 0100	Format type (JX-10)
f 0010 0000	Level # = 1
g 0000 00gg	Group # gg = 01 Tone A gg = 10 Tone B
h 00pp pppp	Parameter # (0 - 58)
i 0vvv vvvv	Value (0 - 127)
:	h and i (repeatedly)
J 1111 0111	End of System Exclusive

Notes :

Parameter #	Function	Value
0-9	NAME-0..9	In ASCII
10	Undefined	
11	DCO-1 RANGE	0 - 31 = 16' 32 - 63 = 8' 64 - 95 = 4' 96 - 127 = 2'
12	DCO-1 WAVEFORM	0 - 31 = Noise 32 - 63 = Sawtooth Wave 64 - 95 = Pulse Wave 96 - 127 = Square Wave
13	DCO-1 TUNE	0 - 127 (-1 oct -- +1 oct)
14	DCO-1 LFO MOD DEPTH	0 - 127
15	DCO-1 ENV MOD DEPTH	0 - 127
16	DCO-2 RANGE	0 - 31 = 16' 32 - 63 = 8' 64 - 95 = 4' 96 - 127 = 2'
17	DCO-2 WAVEFORM	0 - 31 = Noise 32 - 63 = Sawtooth Wave 64 - 95 = Pulse Wave 96 - 127 = Square Wave
18	DCO-2 CROSSMOD	0 - 31 = OFF 32 - 63 = SYNC 1 64 - 95 = SYNC 2 96 - 127 = XMOD (cross modulation)
19	DCO-2 TUNE	0 - 127 (-1 oct -- +1 oct)
20	DCO-2 FINE TUNE	0 - 127 (-50 cent -- +50 cent)
21	DCO-2 LFO MOD DEPTH	0 - 127
22	DCO-1 ENV MOD DEPTH	0 - 127
23	Undefined	
24	Undefined	
25	Undefined	
26	DCO DYNAMICS	0 - 31 = OFF 32 - 63 = 1 64 - 95 = 2 96 - 127 = 3
27	DCO ENV MODE	0 - 31 = ENV-2 Inverted 32 - 63 = ENV-2 Normal 64 - 95 = ENV-1 Inverted 96 - 127 = ENV-1 Normal
28	MIXER DCO-1	0 - 127

29	MIXER DC0-2	0 - 127
30	MIXER ENV MOD DEPTH	0 - 127
31	MIXER DYNAMICS	0 - 31 = OFF 32 - 63 = 1 64 - 95 = 2 96 - 127 = 3
32	MIXER ENV MODE	0 - 31 = ENV-2 Inverted 32 - 63 = ENV-2 Normal 64 - 95 = ENV-1 Inverted 96 - 127 = ENV-1 Normal
33	HPF CUTOFF FREQ	0 - 31 = 0 32 - 63 = 1 64 - 95 = 2 96 - 127 = 3
34	VCF CUTOFF FREQ	0 - 127
35	VCF RESONANCE	0 - 127
36	VCF LFO MOD DEPTH	0 - 127
37	VCF ENV MOD DEPTH	0 - 127
38	VCF KEY FOLLOW	0 - 127
39	VCF DYNAMICS	0 - 31 = OFF 32 - 63 = 1 64 - 95 = 2 96 - 127 = 3
40	VCF ENV MODE	0 - 31 = ENV-2 Inverted 32 - 63 = ENV-2 Normal 64 - 95 = ENV-1 Inverted 96 - 127 = ENV-1 Normal
41	VCA LEVEL	0 - 127
42	VCA DYNAMICS	0 - 31 = OFF 32 - 63 = 1 64 - 95 = 2 96 - 127 = 3
43	CHORUS	0 - 31 = OFF 32 - 63 = 1 64 - 127 = 2
44	LFO WAVEFORM	0 - 31 = Random 32 - 63 = Square Wave 64 - 127 = Triangle Wave
45	LFO DELAY TIME	0 - 127
46	LFO RATE	0 - 127
47	ENV-1 ATTACK TIME	0 - 127
48	ENV-1 DECAY TIME	0 - 127
49	ENV-1 SUSTAIN LEVEL	0 - 127
50	ENV-1 RELEASE TIME	0 - 127
51	ENV-1 KEY FOLLOW	0 - 31 = OFF 32 - 63 = 1 64 - 95 = 2 96 - 127 = 3
52	ENV-2 ATTACK TIME	0 - 127
53	ENV-2 DECAY TIME	0 - 127
54	ENV-2 SUSTAIN LEVEL	0 - 127
55	ENV-2 RELEASE TIME	0 - 127
56	ENV-2 KEY FOLLOW	0 - 31 = OFF 32 - 63 = 1 64 - 95 = 2 96 - 127 = 3
57	Undefined	
58	VCA ENV MODE	0 - 63 = Gate 64 - 127 = ENV-2 Normal

3.5.1 Bulk Dump [PATCH]

Byte	Description
a 1111 0000	Exclusive status
b 0100 0001	Roland ID #
c 0011 0111	Operation code = BLD (bulk dump)
d 0000 nnnn	Unit # = control channel, nnnn = 0 - 15 where nnnn + 1 = channel #
e 0010 0100	Format type (JX-10)
f 0011 0000	Level # = 2 Patch
g 0000 0001	Group #
h 0000 0000	PG# indicates the Patch number
i 00pp pppp	Patch number (0 - 63)
j 0000 vvvv	Value (0 - 15)
:	in sequence (96 bytes total)
k 1111 0111	End of System Exclusive

Notes :

Bulk Dump [PATCH] is available the Internal Memory PATCH A1 - H8(pppppp = 0 - 63) only.

3.5.2 Bulk Dump [TONE]

Byte	Description
a 1111 0000	Exclusive status
b 0100 0001	Roland ID #
c 0011 0111	Operation code = BLD (bulk dump)
d 0000 nnnn	Unit # = control channel, nnnn = 0 - 15 where nnnn + 1 = channel #
e 0010 0100	Format type (JX-10)
f 0010 0000	Level # = 1 Tone
g 0000 0001	Group #
h 0000 0000	PG# indicates the Tone
i 00tt tttt	Tone number (0 - 49)
j 0vvv vvvv	Value (0 - 127)
:	in sequence (59 bytes total)
k 1111 0111	End of System Exclusive

Notes :

Bulk Dump [TONE] is available the Internal Memory TONE # 1 - 50 (tttttt = 0 -49) only.

3.5.3 Sequence of Bulk Dump

- 1: Bulk Dump [PATCH] message repeats 64 times.
- 2: Bulk Dump [TONE] message repeats 50 times.

4. RECOGNIZED EXCLUSIVE MESSAGES

All Exclusive messages described in section 3.

3.5 Bulk Dump (BLD)

* How to enter to 'BULK DUMP' mode :

1. Press both MIDI and WRITE button.
2. Select BULK DUMP by ALPHA-DIAL, then press ENTER.