

PARAPHONIC

RS-505 SERVICE NOTES

CONTENTS

	PAGE
SPECIFICATIONS	1
CIRCUIT DESCRIPTION	2
BLOCK DIAGRAM	4
TONE DIVIDER & TONE GATE GTH-9/10/11	5
MOTHER BOARD OPH-28	6
STRINGS VOICING & SYNTHESIZER VCFH-2	8
KEY TRIGGER & ENVELOPE GENERATOR .. ARH-1	9
BASS VOICING & LFO LFOH-2	10
PITCH SHIFT OPH-29	11
ENSEMBLE MODULATOR ETH-7	12
POWER SUPPLY PSH-28/29/30	14
PARTS LAYOUT	15
PARTS LIST	16
KEYBOARD PARTS	17

DISASSEMBLY

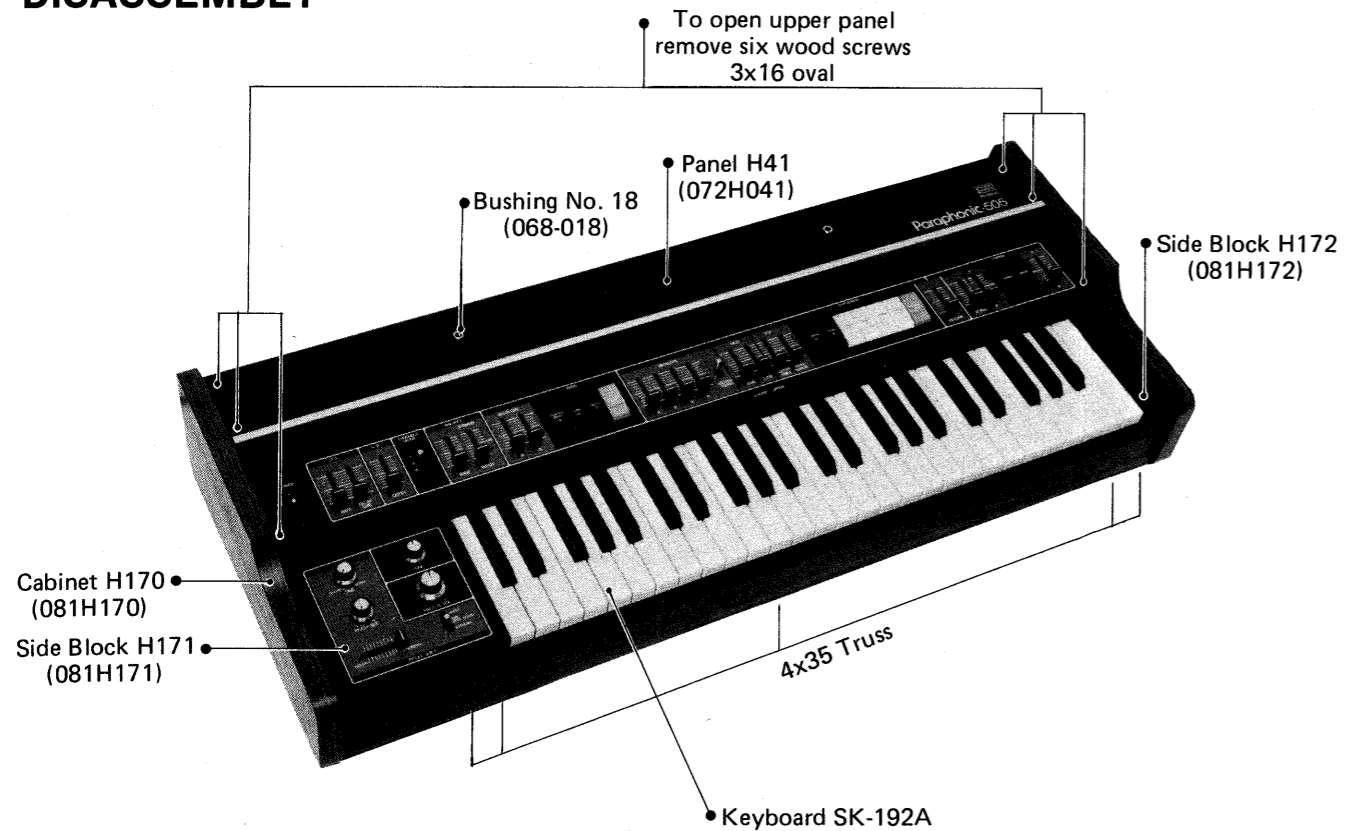

SPECIFICATIONS

Keyboard:	49-Note C Scale
Strings Section	
Tablets:	Upper Strings, Lower Strings
Controls:	4'-8' Mix (U/L), Attack
Strings/Synthesizer Section	
Control:	Release
Synthesizer Section	
Tablets:	Upper 4', Upper 8', Lower 4', Lower 8', Bass 8', Bass 16', Ensemble
Controls:	Resonance, Cutoff Frequency, LFO Sensitivity, Envelope Sensitivity, Attack, Decay, Sustain, Release
Switch:	Second Touch On/Off
Bass Section	
Tablets:	Cello 8', Tuba 16', Contra Bass 16', Ensemble
Controls:	Attack, Release
Balance Control:	Strings-Synthesizer, Bass Volume
Ensemble Switch:	Mode Selection
Vibrato Control:	Depth
LFO Controls:	Rate, Delay Time
Pitch Shift	
Controls:	Manual, Time, Pitch Set
Switch:	Auto/Off/Manual Selection
General	
Controls:	Tune, Master Volume
Switch:	Power
Rear Panel	
Control:	Ensemble Tone
Switches:	Output Level Synth/Bass, Stereo/Mono
Jacks:	Output Stereo, Mono, Bass/Synth, Trig, Gate
	Input Ext, Sustain, Pitch, VCF
Power Consumption:	14W
Dimensions:	905 (W) x 370 (D) x 145 (H) mm
Weight:	14Kg

PCB & CIRCUIT DESCRIPTION

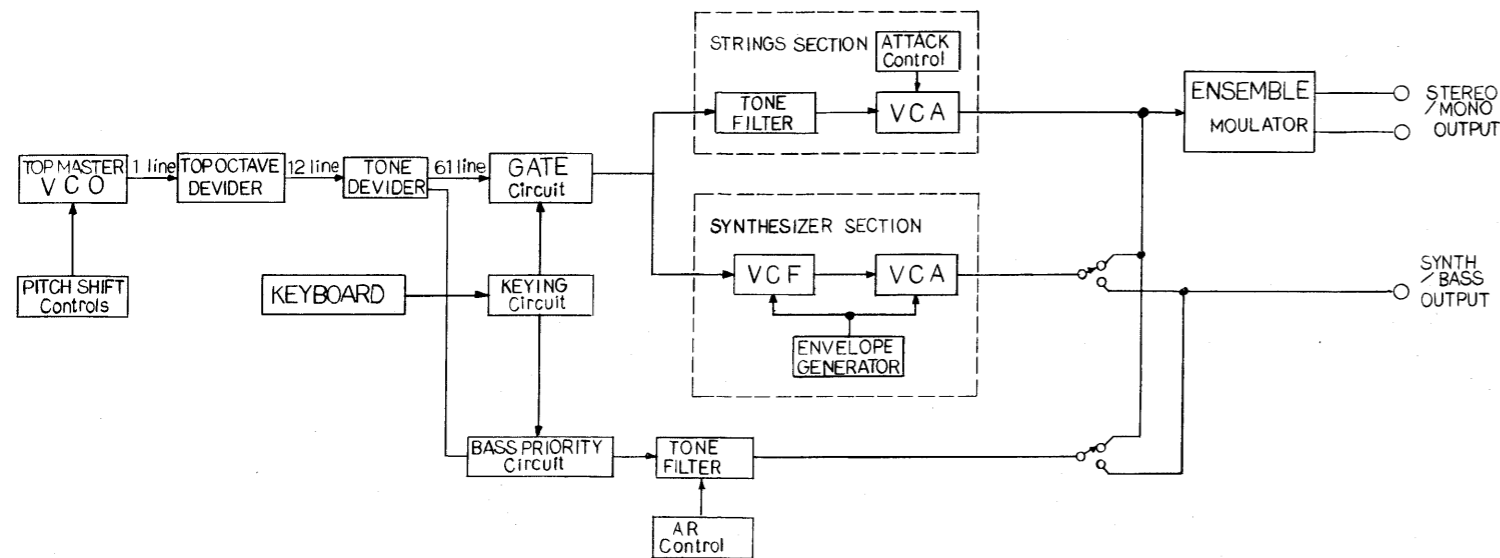

RS-505 CIRCUIT DESCRIPTION

PCB AND CIRCUIT DESCRIPTION

1. Mother Board OPH-28

1-1. Master VCO

This is basically an LC oscillator whose frequency is variable by changing the voltage applied to varicap diode.

Maximum pitch shift range is 1 octave.

Frequency stability is within 15 cents at normal working temperature.

1-2. Top Octave Divider

The VCO output is divided to create 12 notes by IC6. The notes are octave downed several times by the tone dividers at the next stage and routed to the corresponding tone gates.

The top octave notes themselves are not supplied to the tone gates.

1-3. Tone Divider, Tone Gate (GTH-9,10,11)

Pressing a keyswitch applies negative voltage to the transistor keying circuit Q1 (Q4, Q7). This negative voltage is applied to the collectors of Q2, Q3 (Q5, Q6) where they are chopped by the signal outputs from the dividers TC-4024's applied to the bases.

The negative voltage from a keyswitch also charges C2 (C5, C8) which discharges upon releasing a key and holds Q1 on. The discharge rate of this capacitor is controlled by the frequency of the pulse that comes from Release Pulse Generator via terminal No.4.

1-4. Bass Priority

Three 8-bit priority encoders TC-4532 generate 6-bit codes by the on/off action of the bass keyswitches. These coded signals are fed to the two IC's (TC4042) and latched. At the same time, the output of TC-4042 is sent to the 8-bit priority decoders at the next stage and one out of 24 bass notes is selected. The latched signals are held until a next bass key signal is given.

The bass gate signals for the bass AR envelope generator are also generated by this priority circuit.

2. String Voicing & Synthesizer VCFH-2

The VCF of the synthesizer section is an LPF of 24dB/oct. Its control voltage is supplied through an Anti-log circuit. The control voltage of the VCA is also supplied through an Anti-log circuit. The level adjusting trimmer pot is mounted on each circuit.

3. Bass Voicing LFO LFOH-2

3-1. Bass Tone Gate

The output signals of the Bass AR Env (Q1, Q2) are chopped by the bass tones at Q5, Q6, and Q7. The output is sent to the tone filters and the VCF of synthesizer section.

3-2. LFO

This is an R-C sine wave oscillator whose frequency is varied from about 1Hz to 15Hz by the RATE control. Its oscillation is once stopped by the gate signal which is generated by depressing a key, then it starts again and the amplitude is gradually increased. The oscillation stop time until the start of oscillation is adjusted by the DELAY TIME control.

4. Key Trigger Detector, Envelope Generator ARH-1

The key trigger detector detects change in key bus current, and it generates pulses by the key on-off operation and trigger pulses by the key on operation.

The envelope generator is triggered by the gate pulse, or by the trigger pulse when the second touch switch is activated.

5. Ensemble Modulator ETH-7

IC's (2AD512D) are used in the 4 sets of audio delay lines. The clock frequency range is 40KHz to 250KHz.

To get various output signals, the processing conditions are different for each of the delay lines: the clock generators are modulated by four different waves, that is, two different triangular waves and two different waves of anti-phase triangular wave plus sine wave.

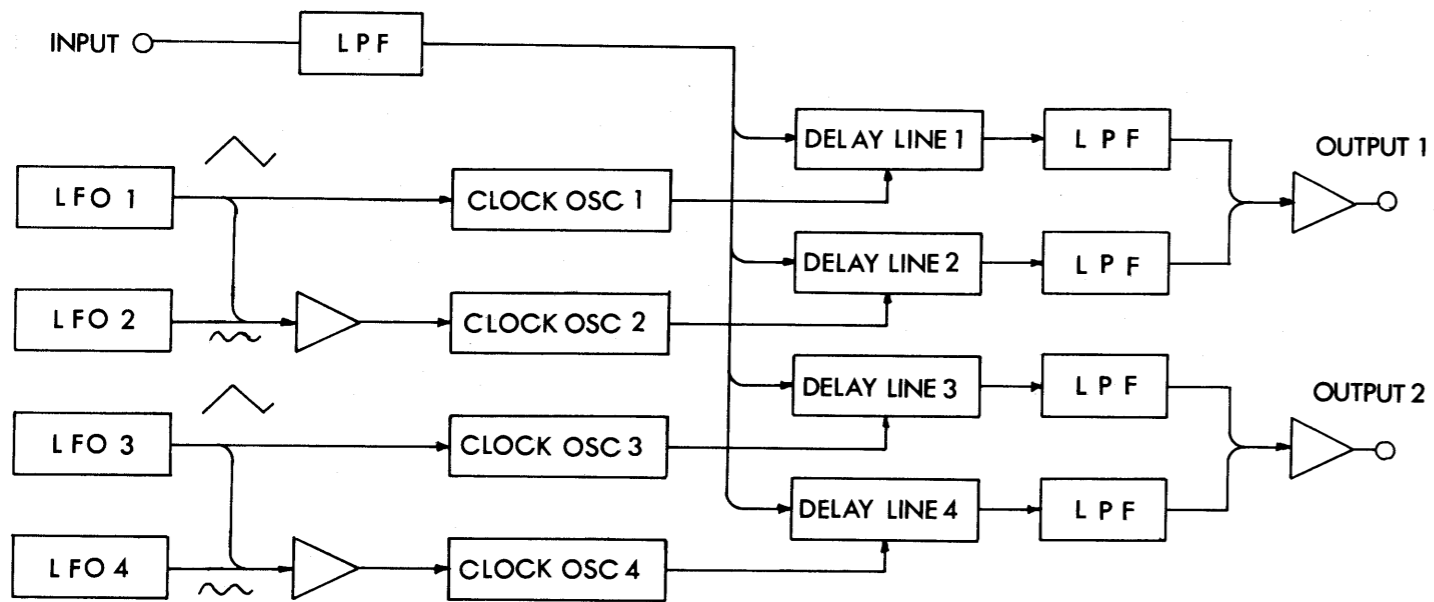

PCB LOCATIONS & INTERWIRING

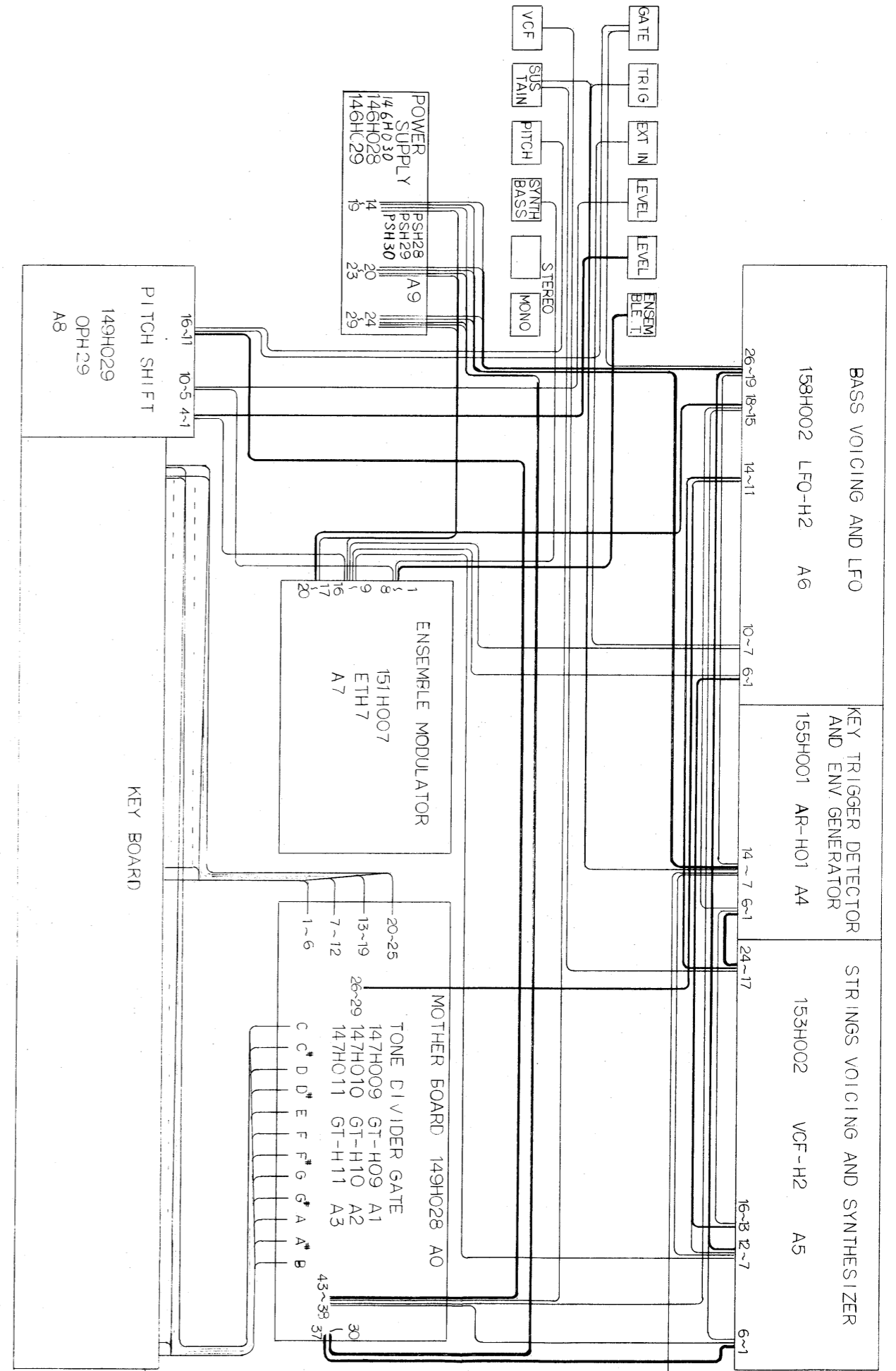

BLOCK DIAGRAM

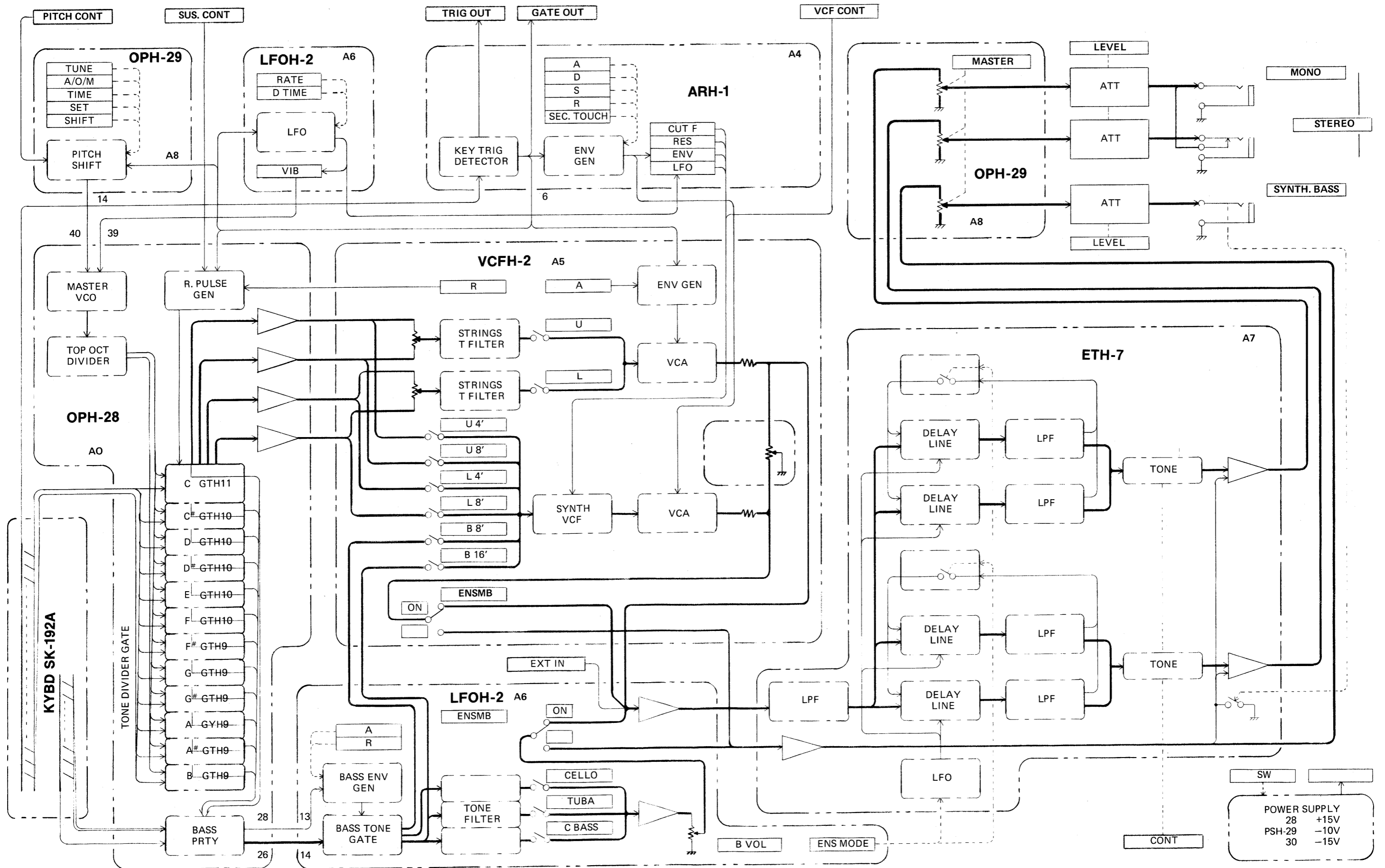

GTH-9 (147H009)
F# ~ B

GTH-10 (147H010)
C# ~ F

VALUES FOR
GTH-10

- R7, 16, 25 = 18K
- R9, 18, 27 = 3K9
- C3 = 0.1
- C4, 6 = 0.047
- C7, 9 = 0.022
- C10 = 0.01
- C12 = 0.012
- C13 = 0.0056

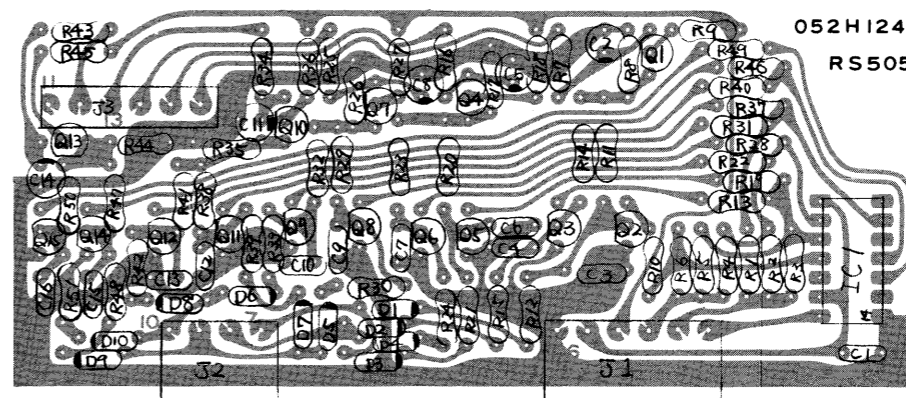
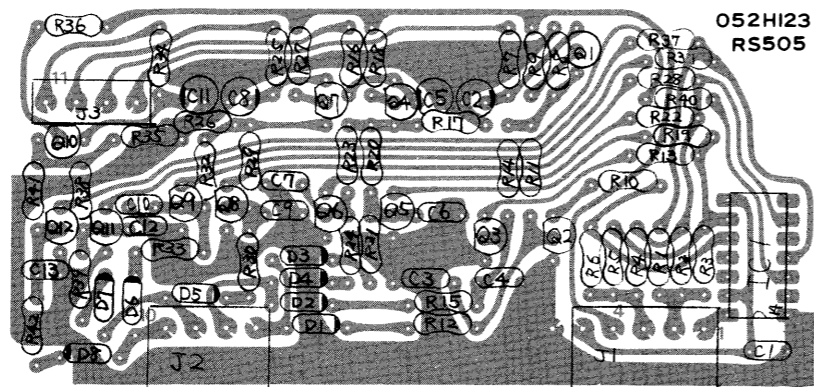

A1.2.3
TONE DIVIDER & GATE
GTH-11 (147H011)
C

- Connectors
- J₁ 5145-06A
 - J₂ 5145-04A
 - J₃ 2373-06A

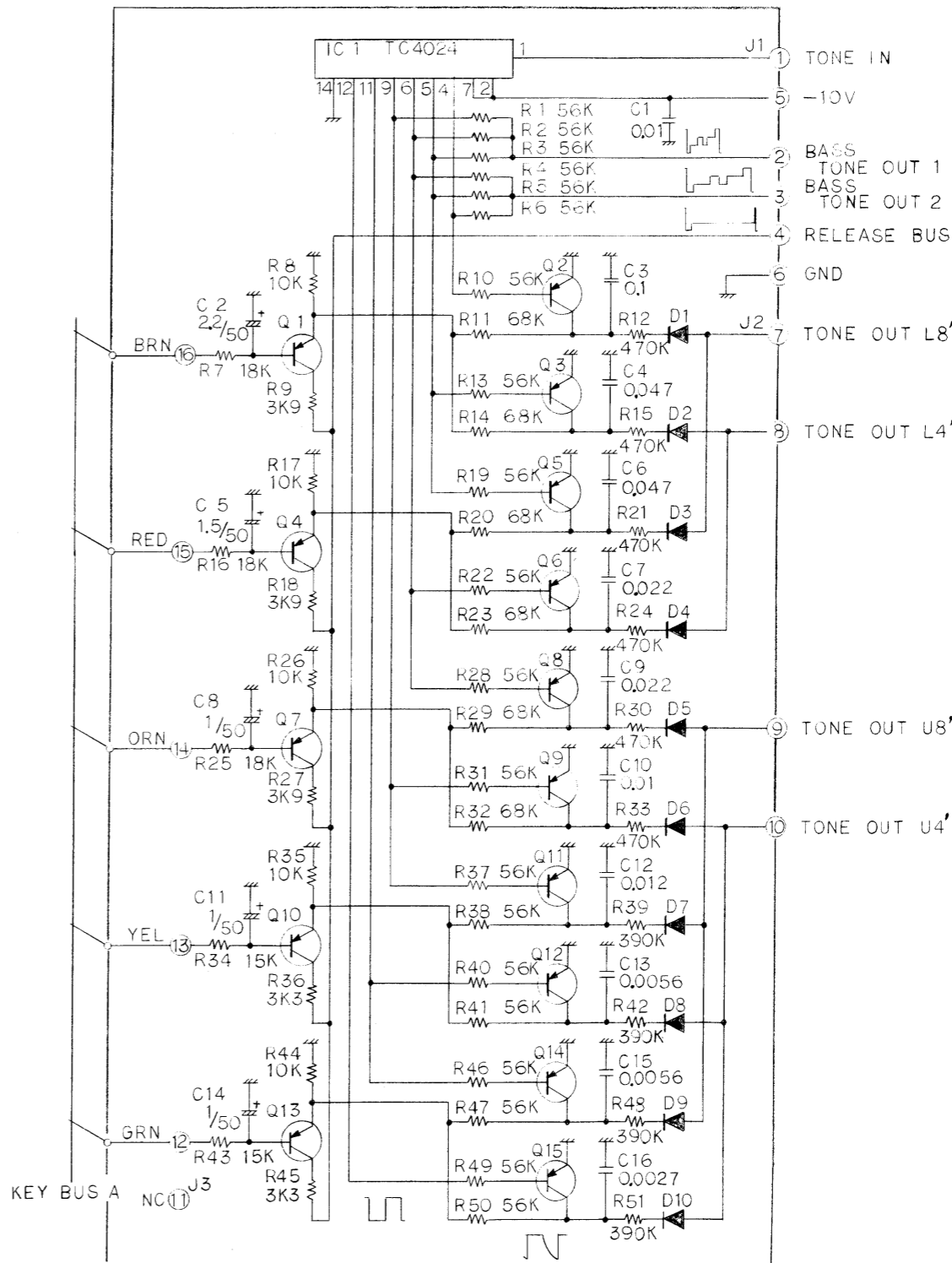
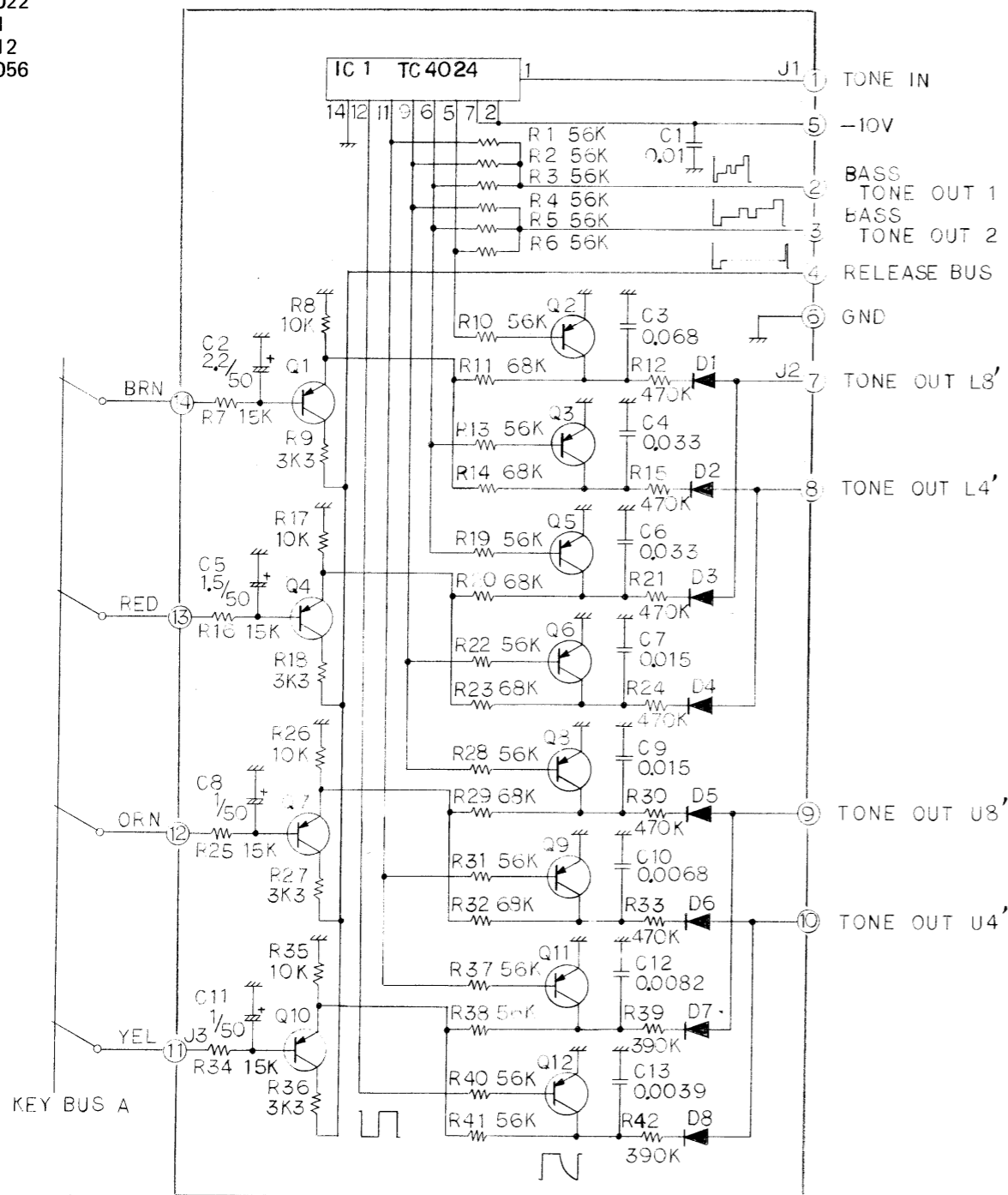

NOTE:
1. UNLESS OTHERWISE SPECIFIED
RESISTOR VALUES ARE IN OHMS
CAPACITOR VALUES ARE IN μF

Q ARE 2SA495 GR-TM or 2SA1C15 GR
D ARE 1S1555 or M8555 or 1S2473

AO
MOTHER BOARD
OPH-28 (149H028)

- L₁ RC-855 (180μH)
(181K)
- D₁₇ SVC-303
- Connectors
- J₅ 5028-04A
- J₁, J₂, J₄, J₇ 5028-06A
- J₃ 5028-07A
- J₆ 5028-08A

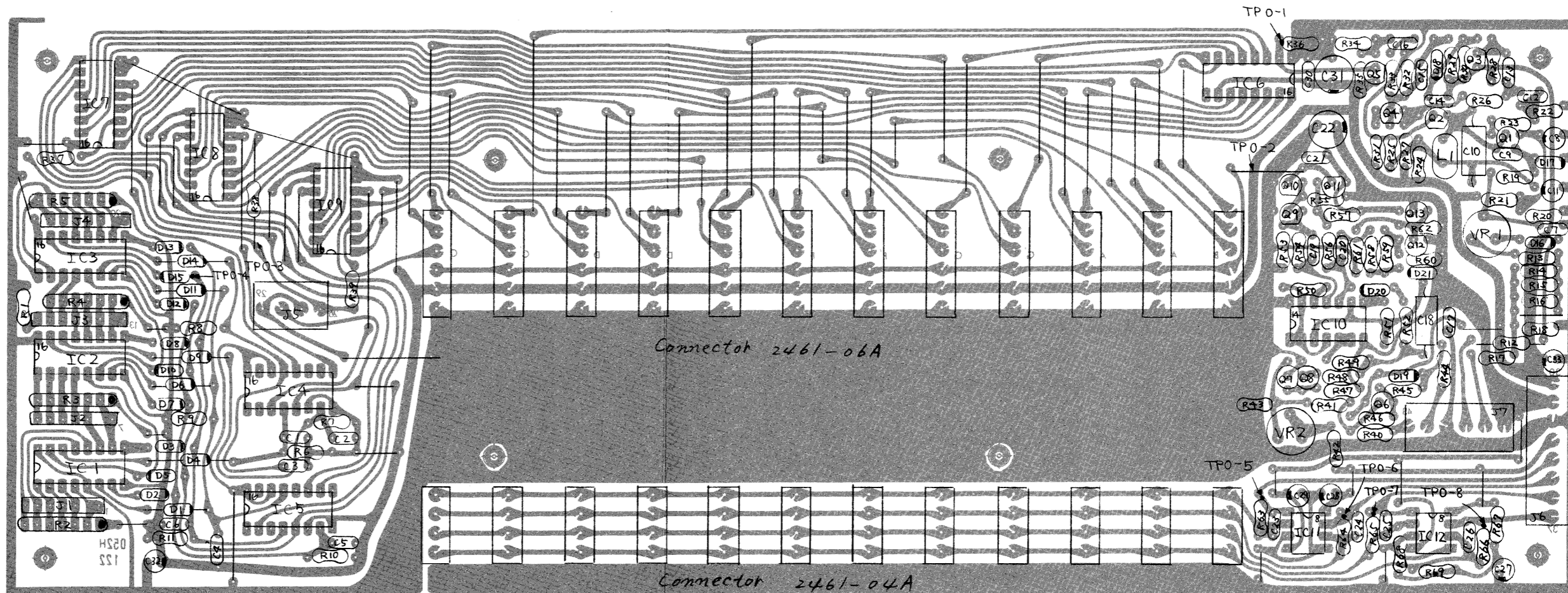

TUNING

The Master VCO should be retuned after:

1. Secondary voltage varies (modification or repairing around the power supply).
2. Components in the VCO are replaced.

When soldered, allow them to dissipate heat for several minutes.

Set Knobs and Switch as shown.
Adjust VR-1 (OPH-28) for 1768Hz at "A" Tone Divider.

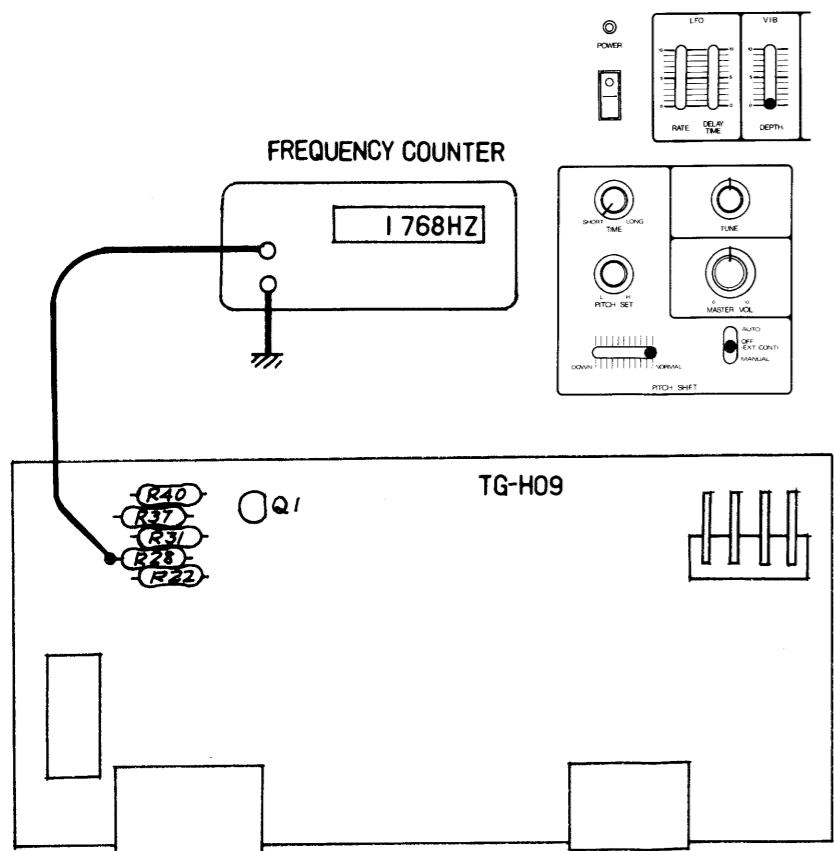

RELEASE PULSE FREQUENCY ADJUSTMENT

Place a closed plug or DP-1 in SUSTAIN jack on the rear panel.

Adjust VR-2 (OPH-28) for:

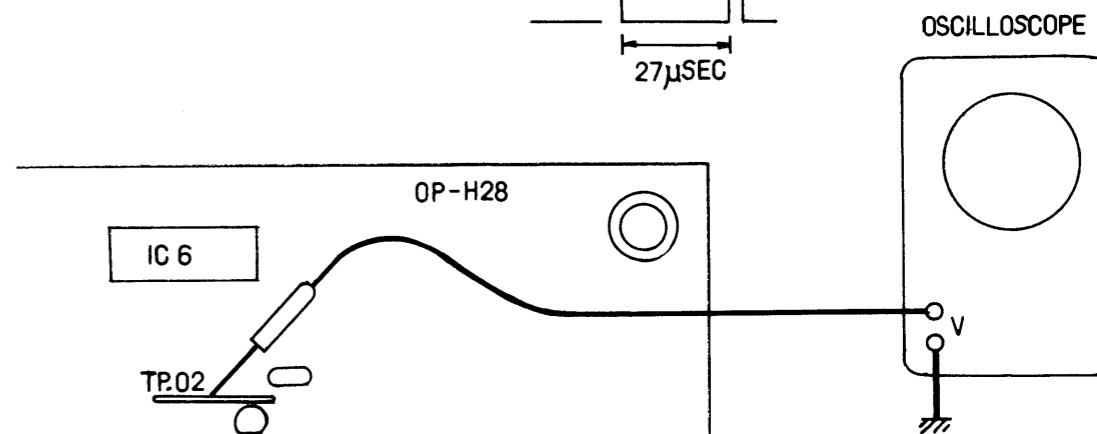
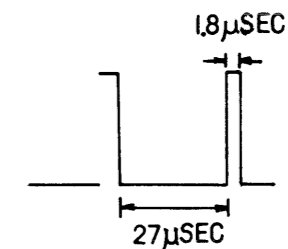

OPH-28

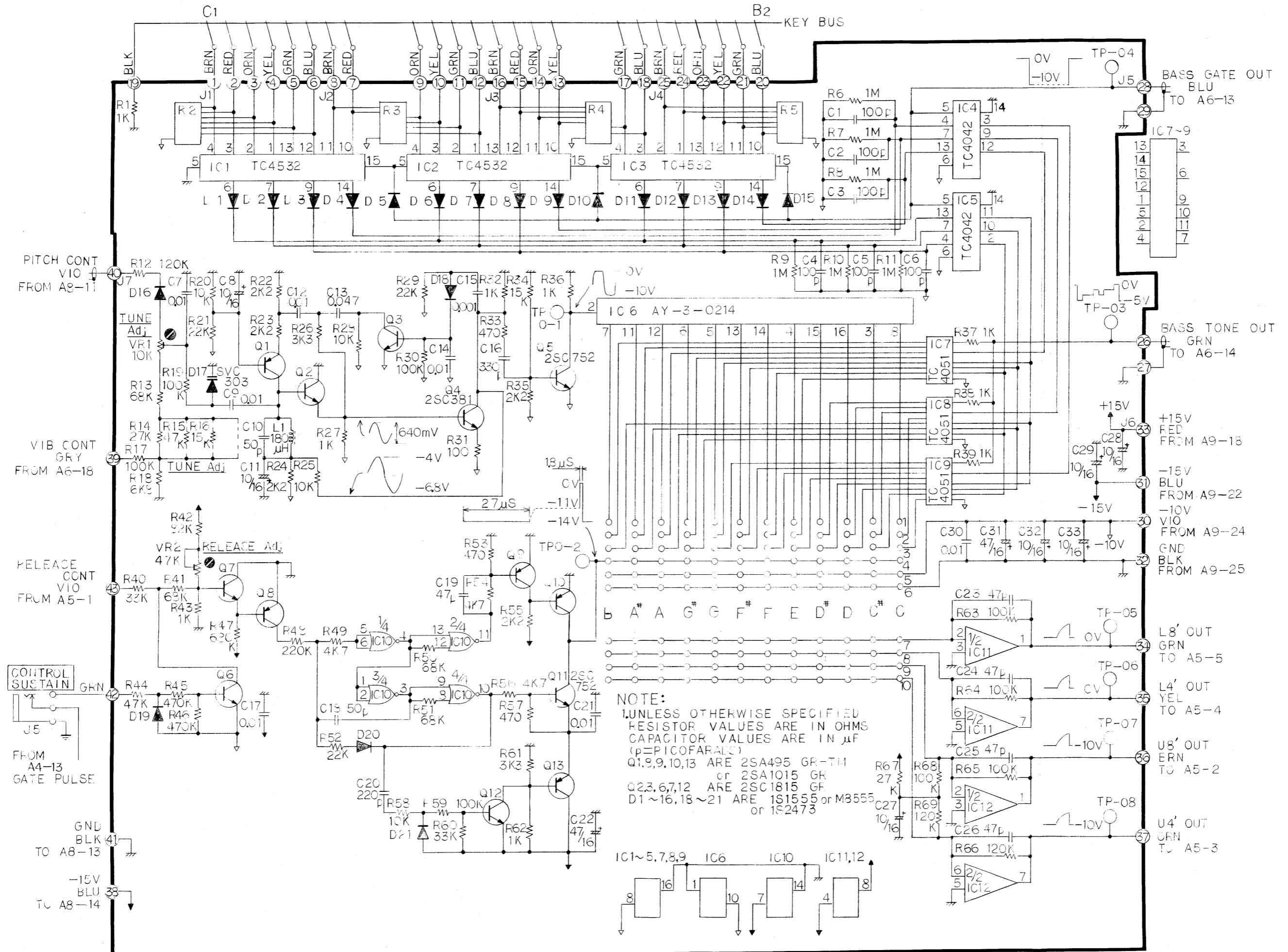

STRINGS VOICING & SYNTHESIZER

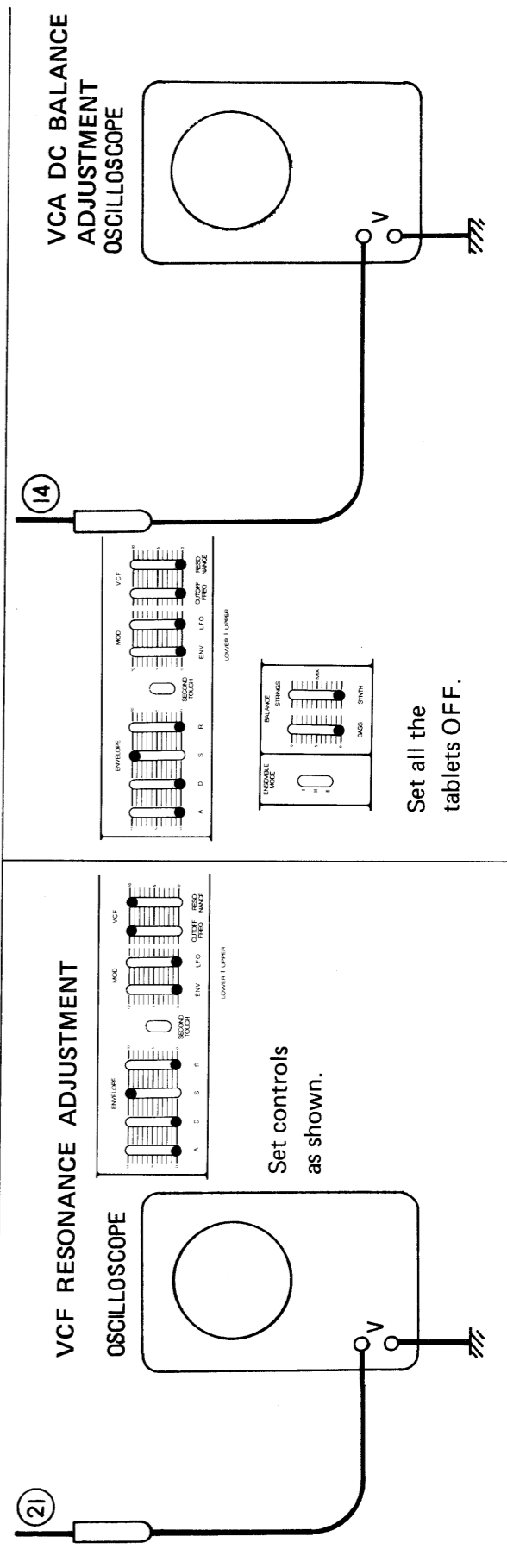
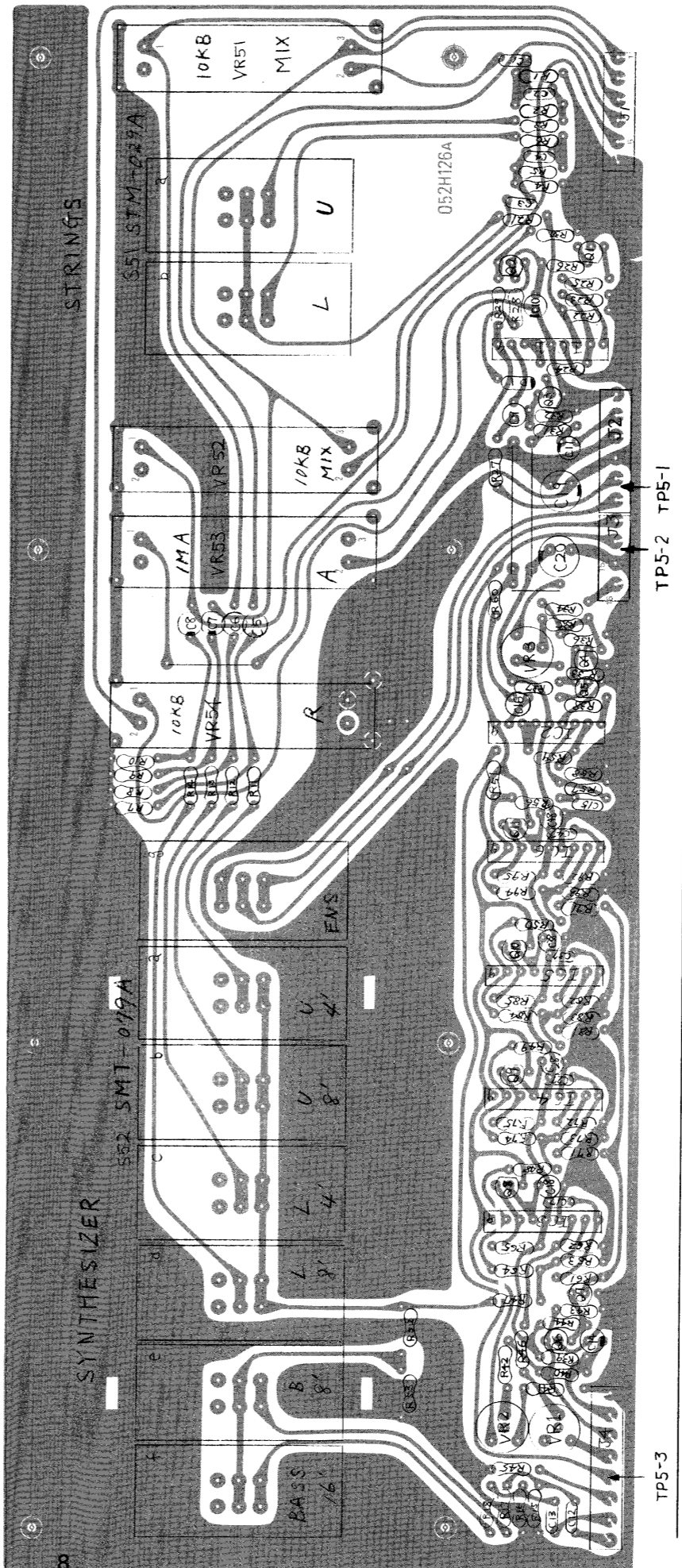
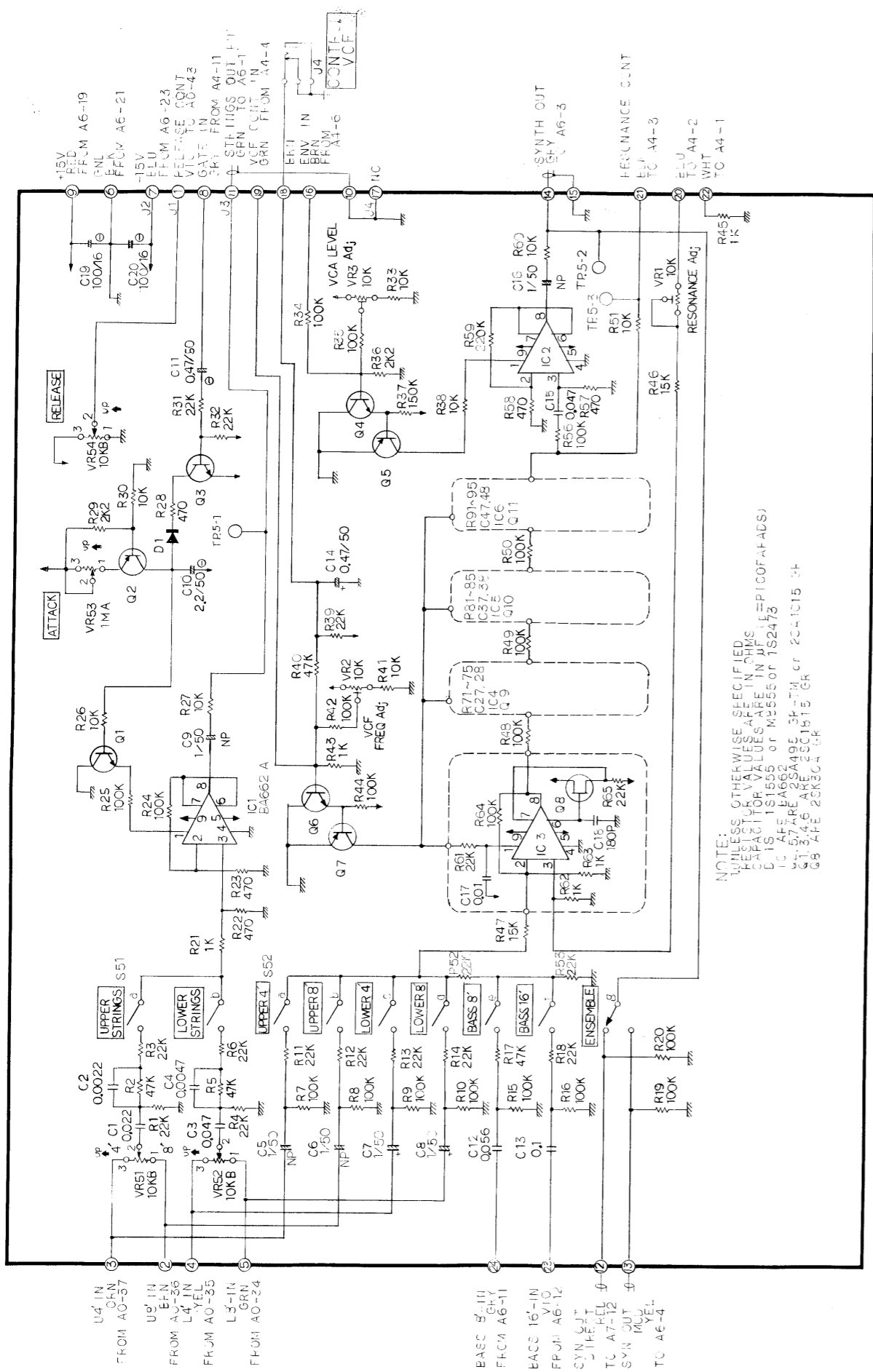

KEY TRIGGER & ENVELOPE GENERATOR

ARH-1A (155H001A)

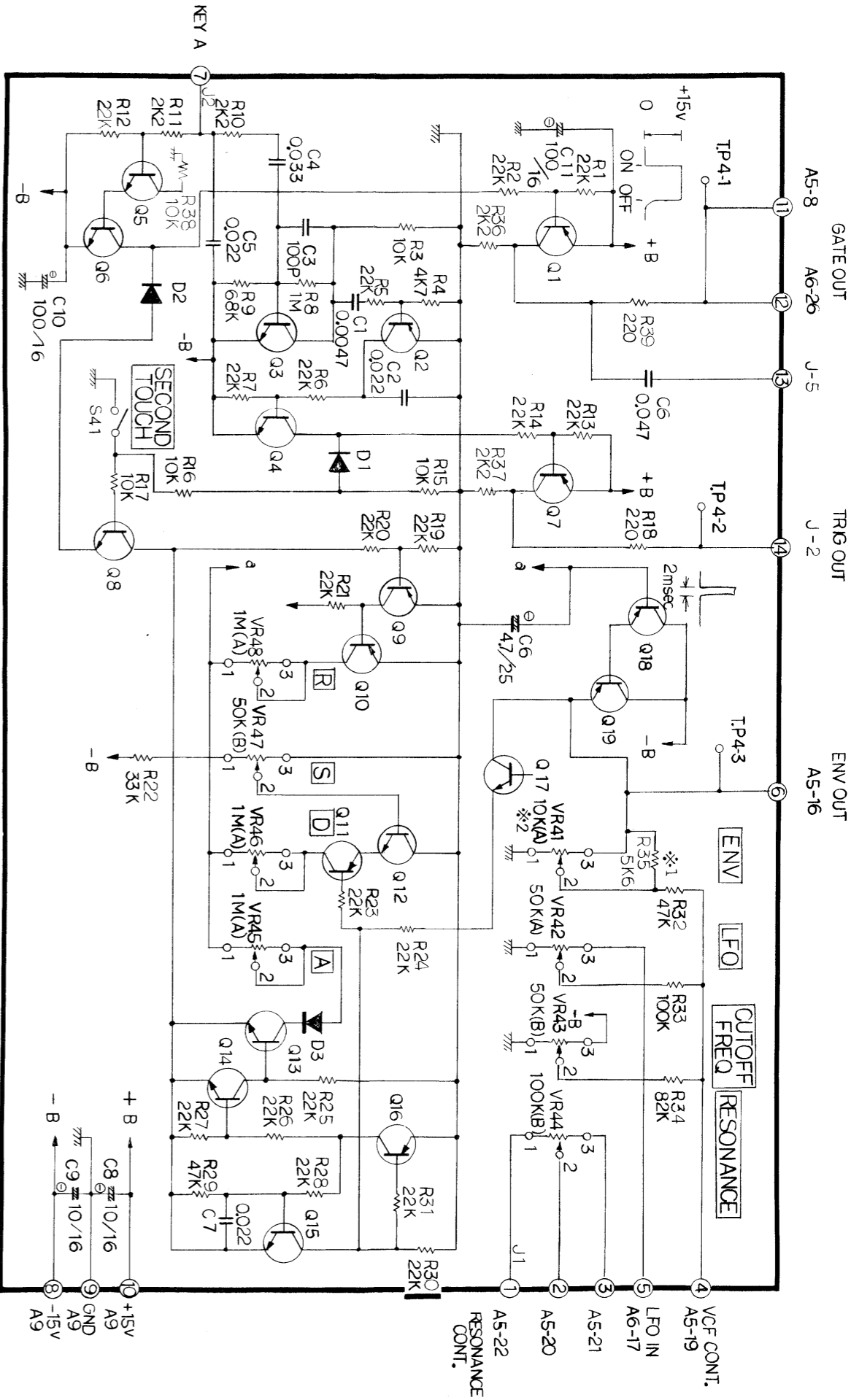

NOTE
 1 UNLESS OTHERWISE SPECIFIED RESISTOR VALUES ARE IN OHMS, CAPACITOR VALUES ARE μ F
 2 Q1,2,7,9,10, 11,16,18,19 ARE 2SA1015 . Q3,4,5,6,8,12,13,14,15,16,17 ARE 2SC1815GR . D ARE M8555

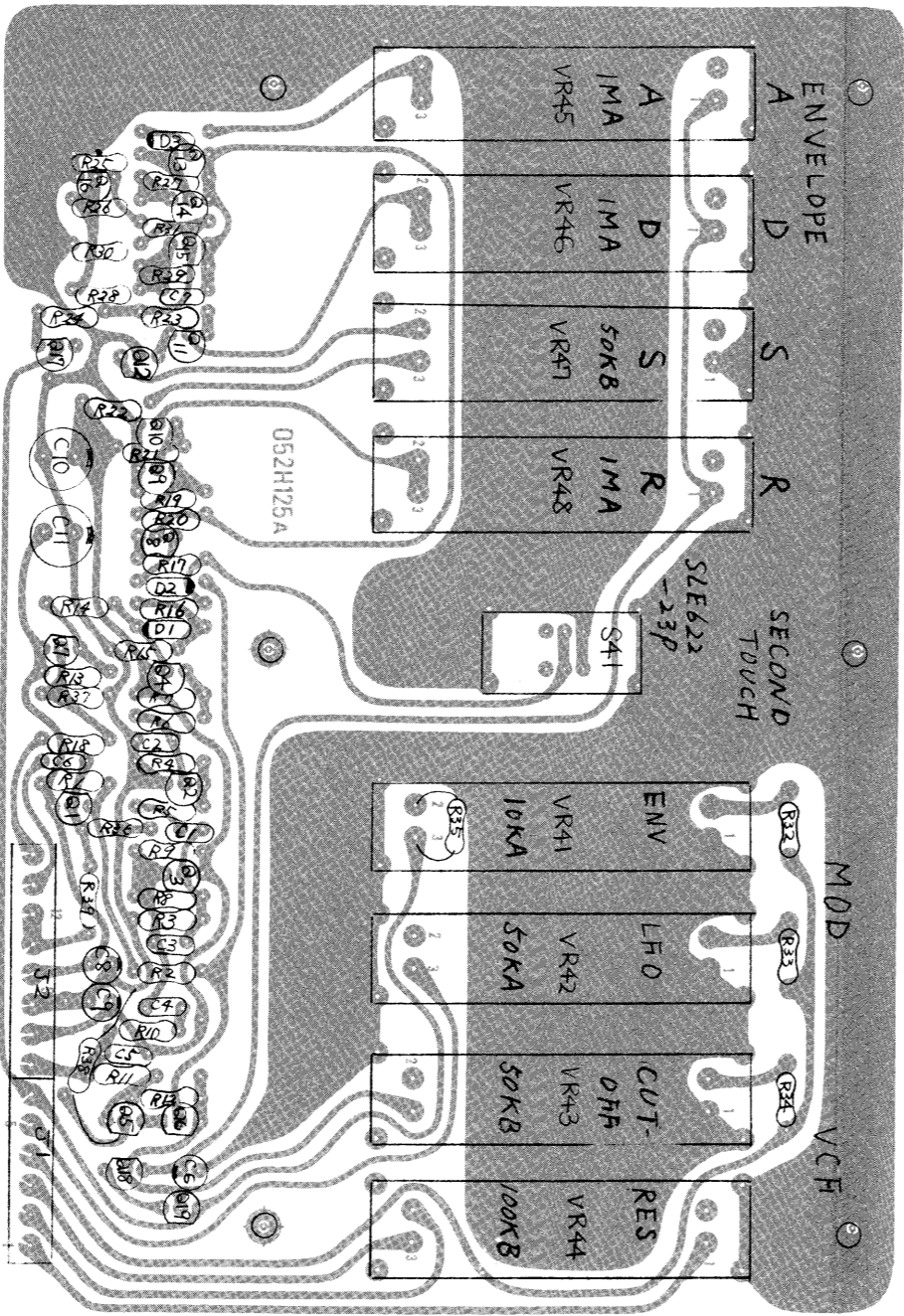

SW S41: SLE-622-23P

Connectors: J₁ 2373-06A
J₂ 2373-08A

While tapping a key, turn VR-3 until click pulse just disappears. Make final adjustment with oscilloscope in most sensitive.

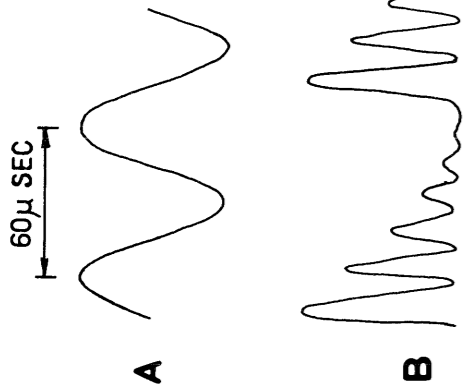

1. Turn VR-1 fullclockwise.
2. Adjust VR-2 for 17kHz. (Fig. A)
3. While depressing a key, adjust VR-1 for Fig. B. (Change Time Sweep Range if necessary).

BASS VOICING & LFO

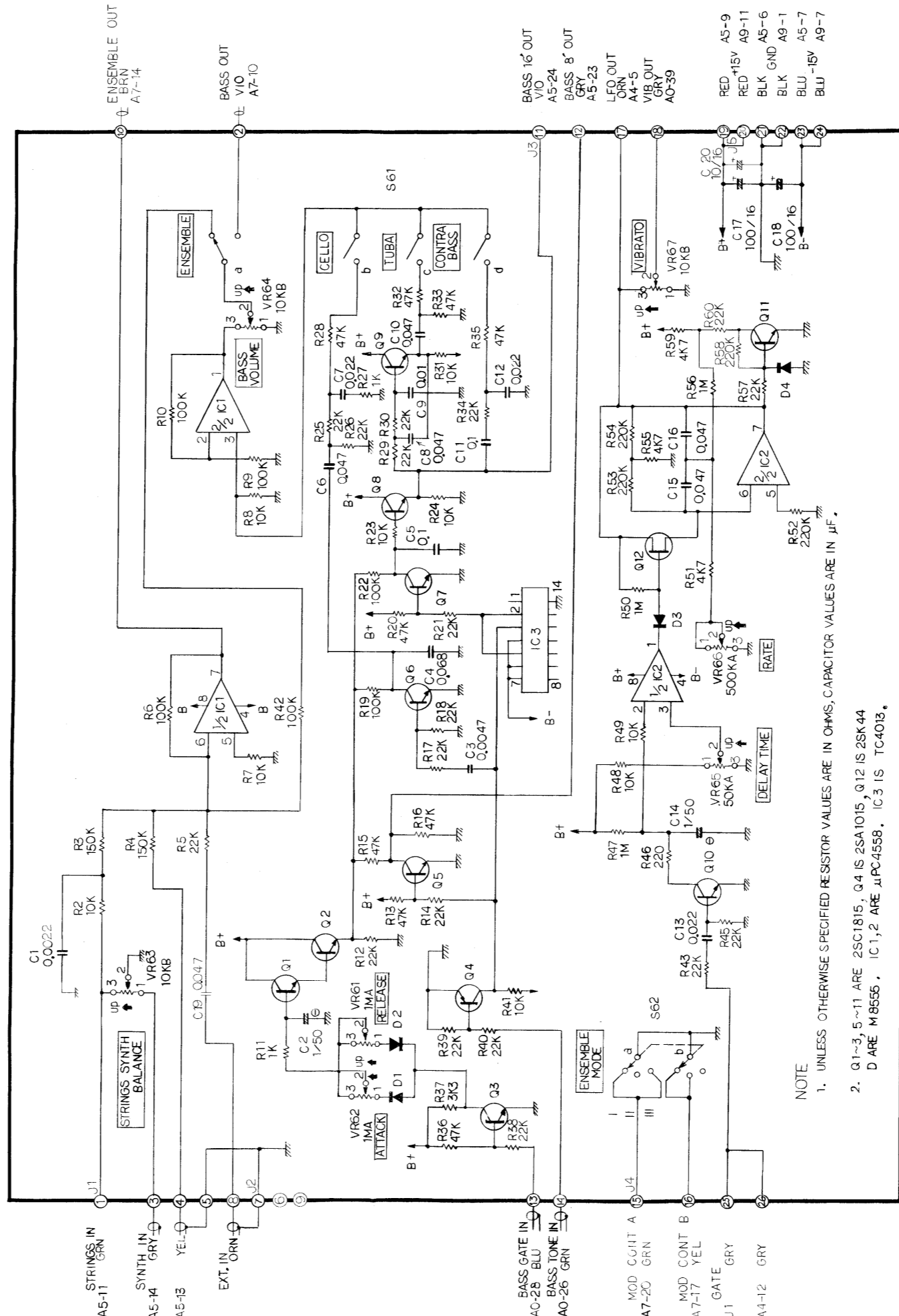
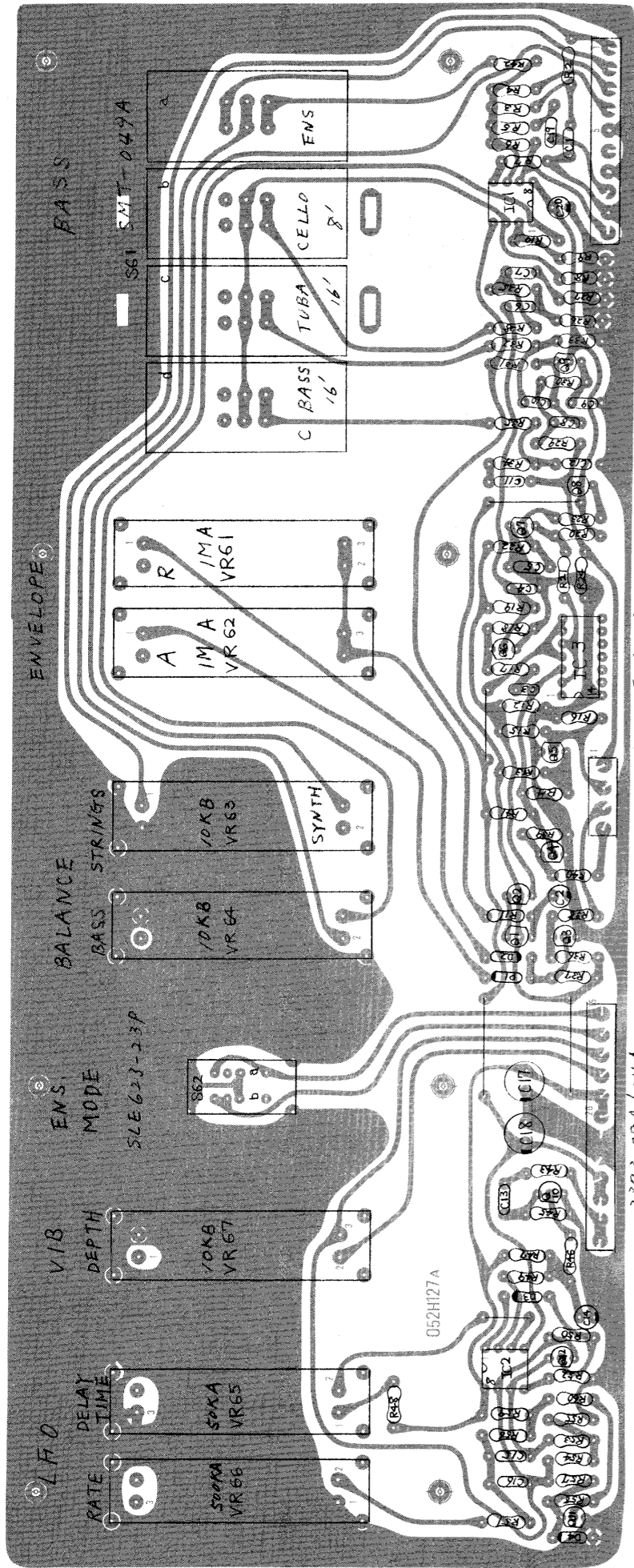

NOTE
 1. UNLESS OTHERWISE SPECIFIED RESISTOR VALUES ARE IN OHMS, CAPACITOR VALUES ARE IN μ F.
 2. Q1-3, 5-11 ARE 2SC1815, Q4 IS 2SA1015, Q12 IS 2SK44
 D ARE M9555. IC1,2 ARE μ PC4558. IC3 IS TC4013.

- BASS 16' OUT VIO A5-24
- BASS 8' OUT GRY A5-23
- LFO OUT ORN A4-5
- VIB OUT GRY AO-39
- RED A5-9
- RED +15V A9-11
- BLK GND A5-6
- BLK A9-1
- BLU -15V A9-7

**PITCH SHIFT
OPH-29 (149H029)**

- S₈₁: SLE643-15P
- J₁: 2373-04A
- J₂: 2373-06A
- J₃: 2373-06A

Serial No. 740300
and higher

- VR85 10KB
- R15 } delete
- R16 } delete
- R17 }

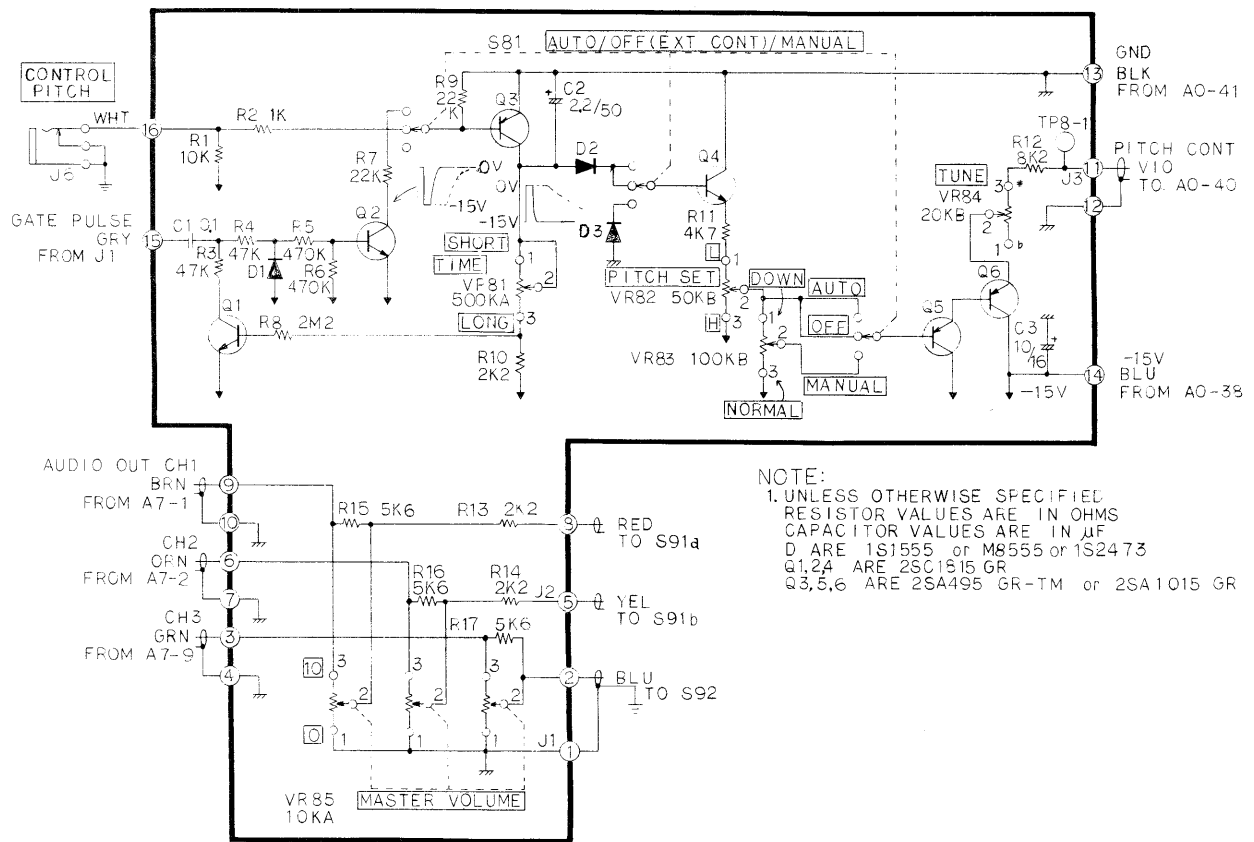
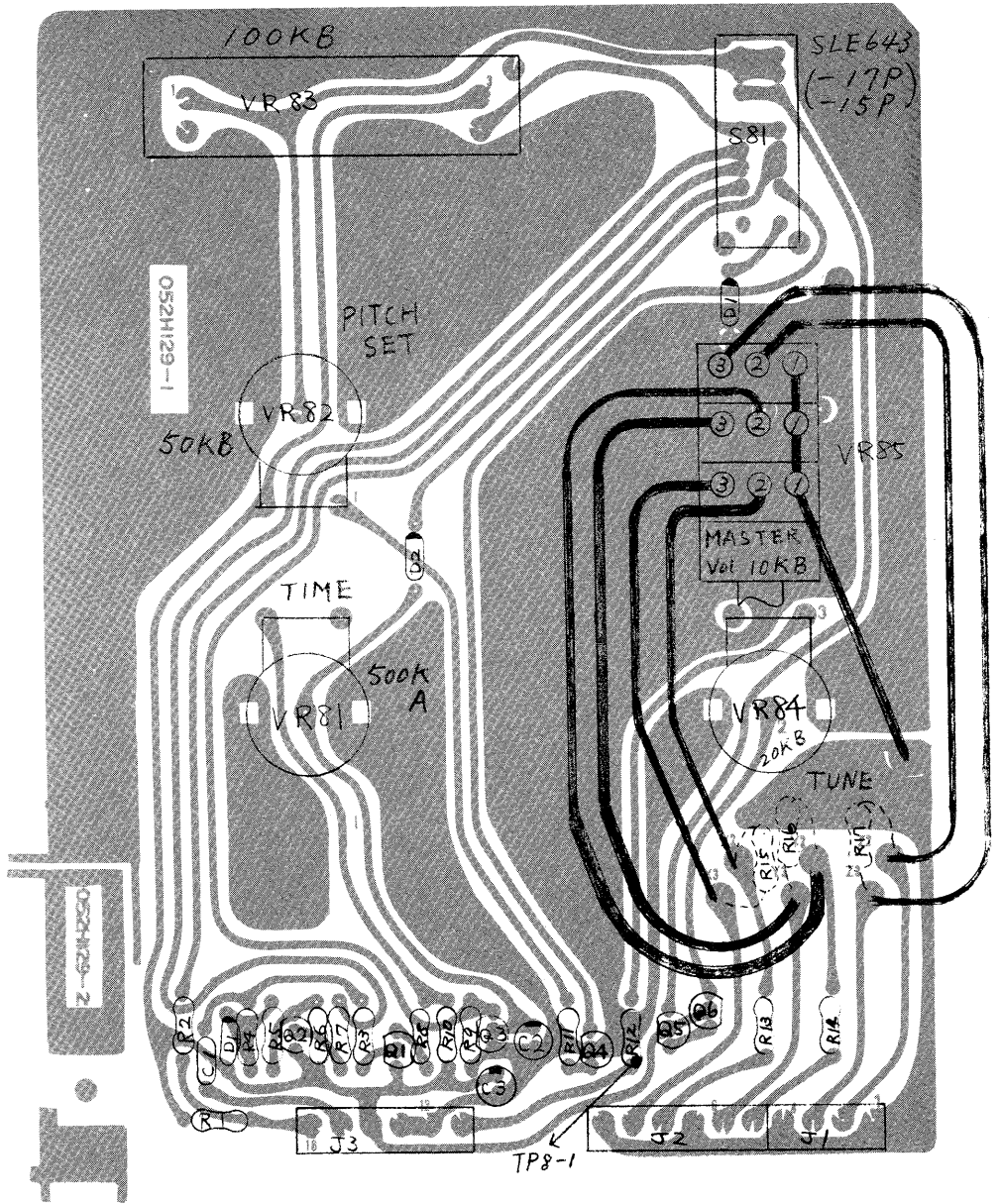

ENSEMBLE MODULATOR ETH-7 (151H007)

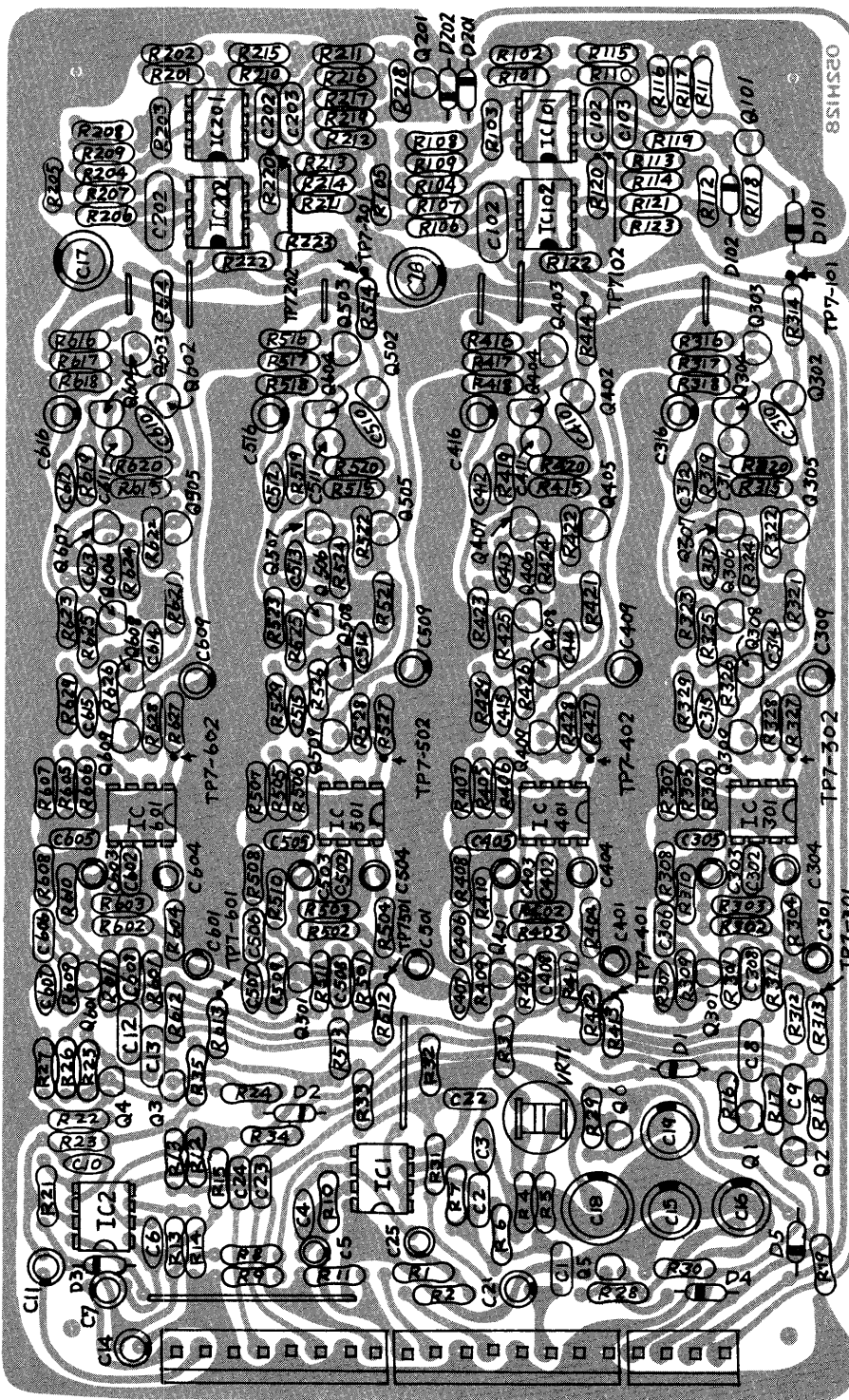

MODULATOR BIAS ADJUSTMENT

- Feed a signal (1kHz, sine, -20dB) into EXT. IN jack on the rear panel.
- Connect an oscilloscope to MONO jack.
- Set ENSEMBLE changeover switch at I.
- Increase the input level until the output is slightly distorted.
- Adjust VR-71 so that positive half and negative are symmetrical.

For easier check on individual channel, connect the scope at the points:
TP7-301, -401, -501 and -601.

ETH-7

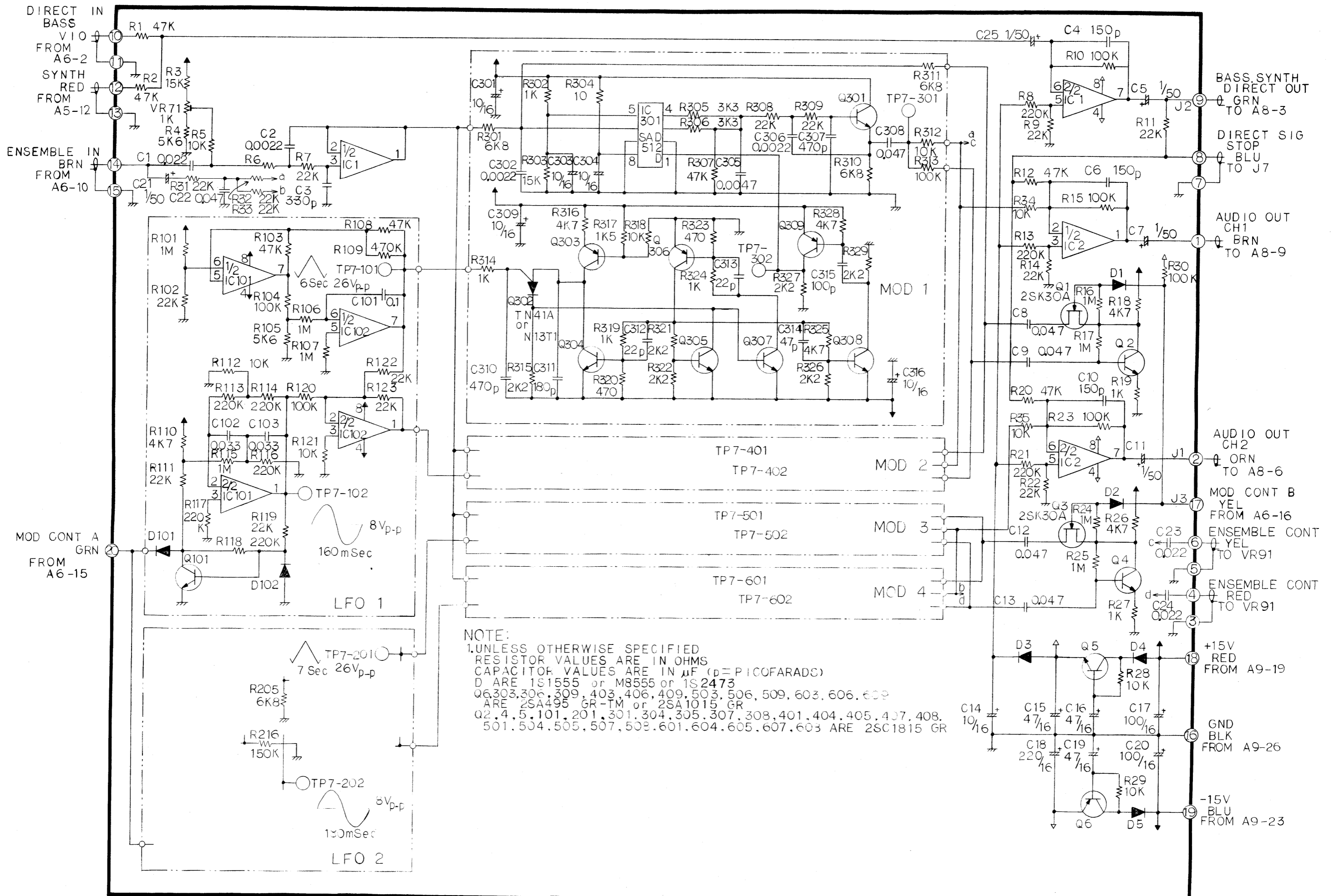

A9
POWER SUPPLY

PSH-28C (146H028C)
100V

PSH-29C (146H029C)
117V

PSH-30C (146H030C)
220/240V

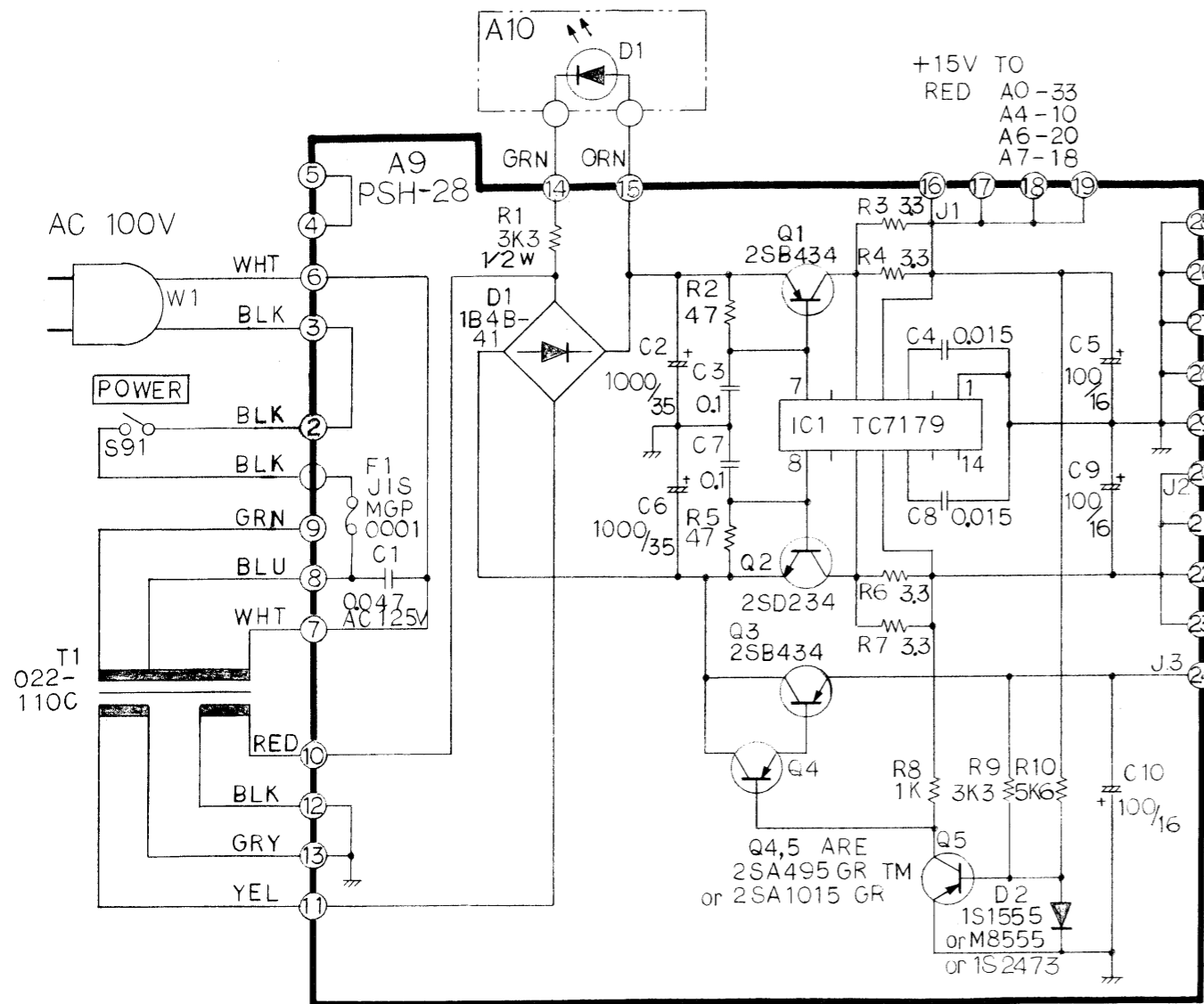

+15V TO
RED A0-33
A4-10
A6-20
A7-18

-15V
BLU TO
A0-31
A4-9
A6-22
A7-16

-10V
VIO TO
A0-30

GND
BLK TO
A0-32
A4-8
A6-24
A7-19

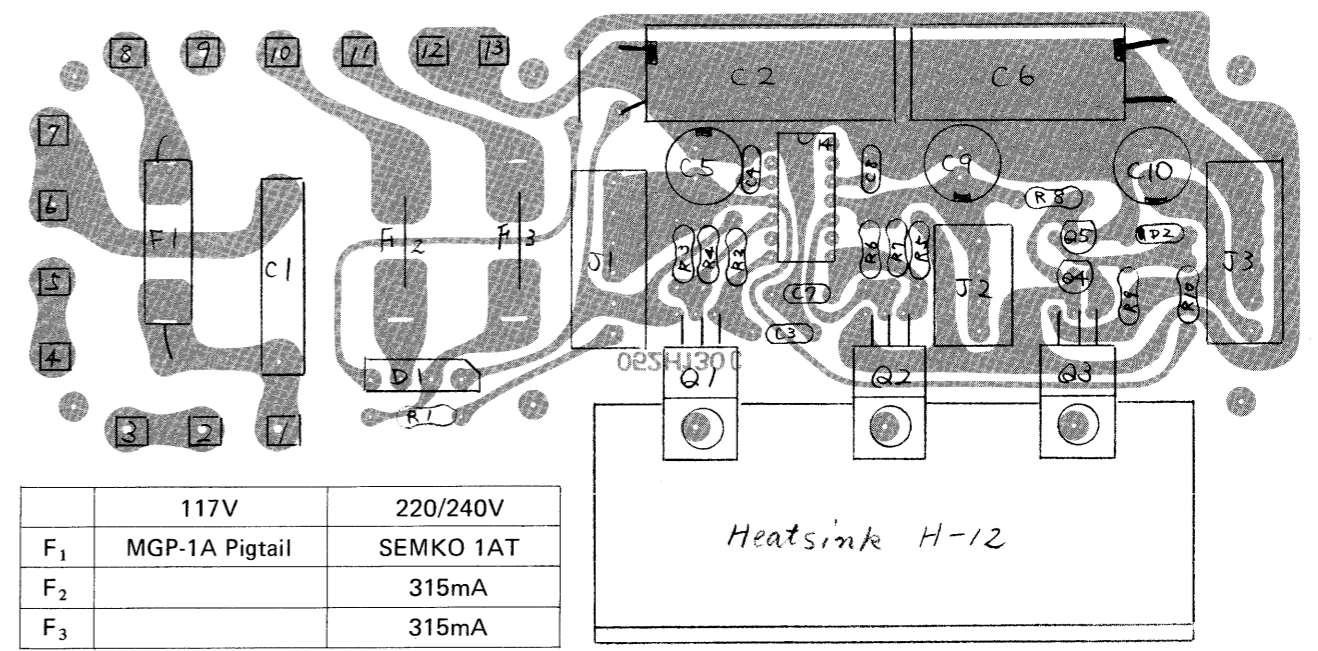
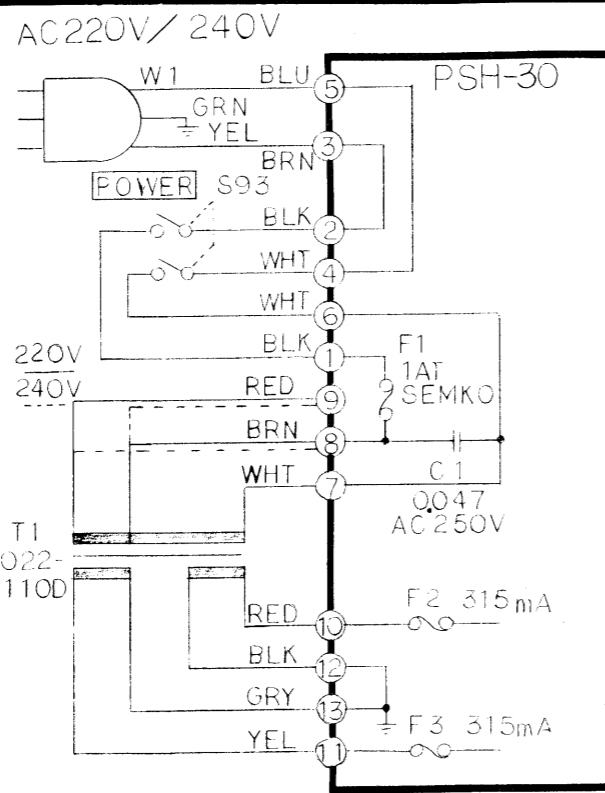
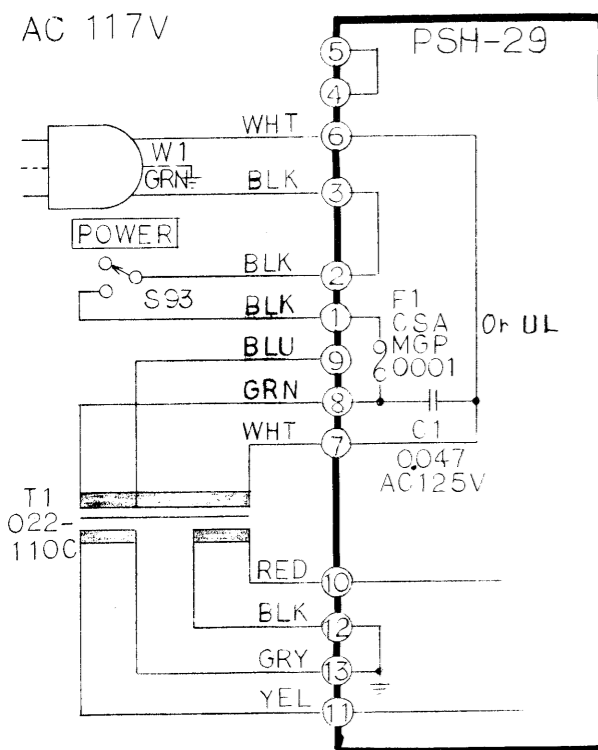
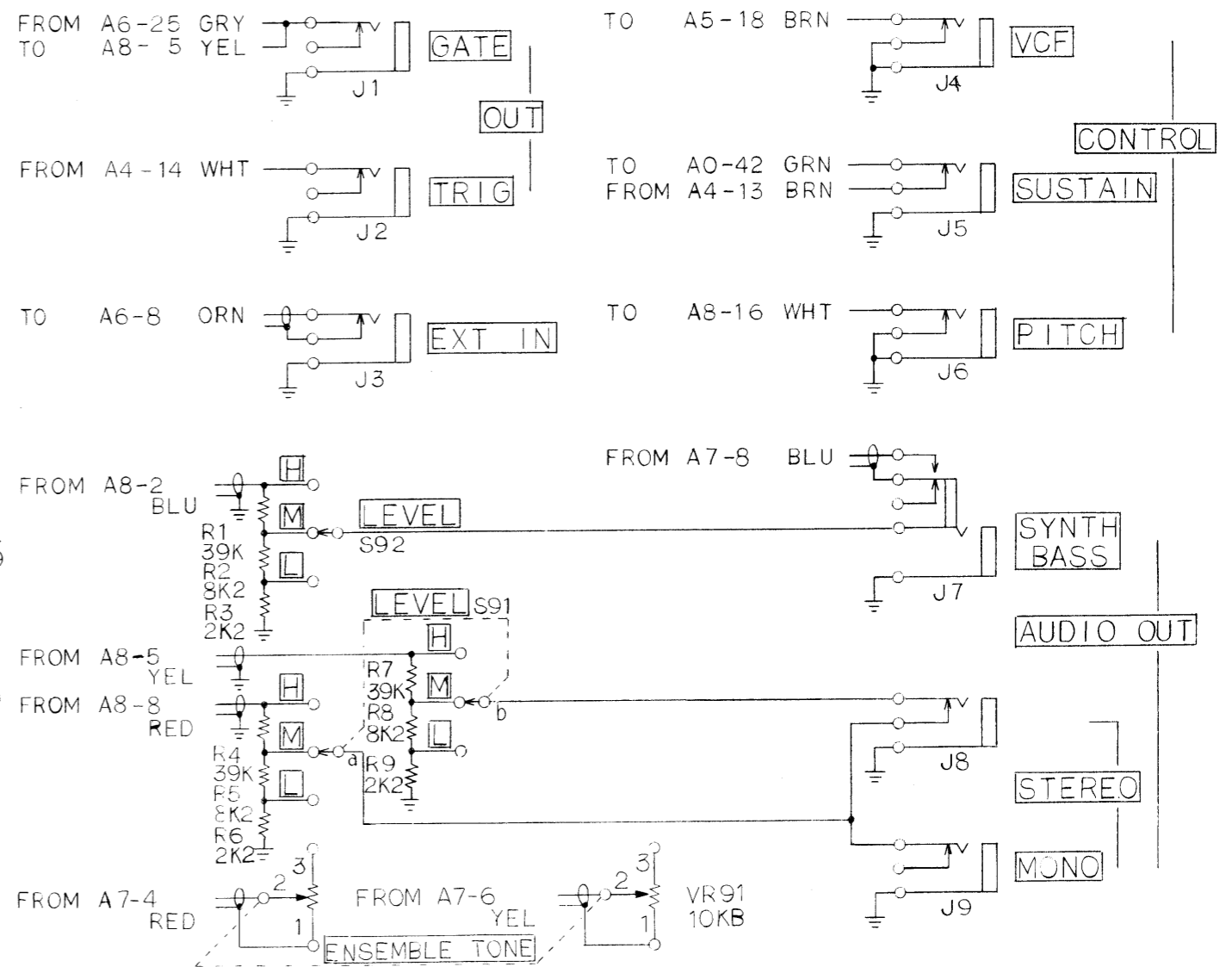

	117V	220/240V
F ₁	MGP-1A Pigtail	SEMKO 1AT
F ₂		315mA
F ₃		315mA

PARTS LAYOUT

POWER SWITCH

SDA1SA-1 (100V)
(001-258)

SDA2SA-1 (117V)
(001-259)

SDE4SA-1 (220/240V)
(001-260)

LED
TLR102KB
(019-027)

LEVER SWITCH
SLE623-23P
(001-257)

TABLET (See Parts List)
SWITCH SMT-049A
(002-005)

LEVER SWITCH
SLE622-23P
(001-255)

TABLET (See Parts List)
SWITCH SMT-079A
(002-006)

RAIL H6
(110H006)

TABLET
(See Parts List)
SWITCH SMT-029A
(002-004)

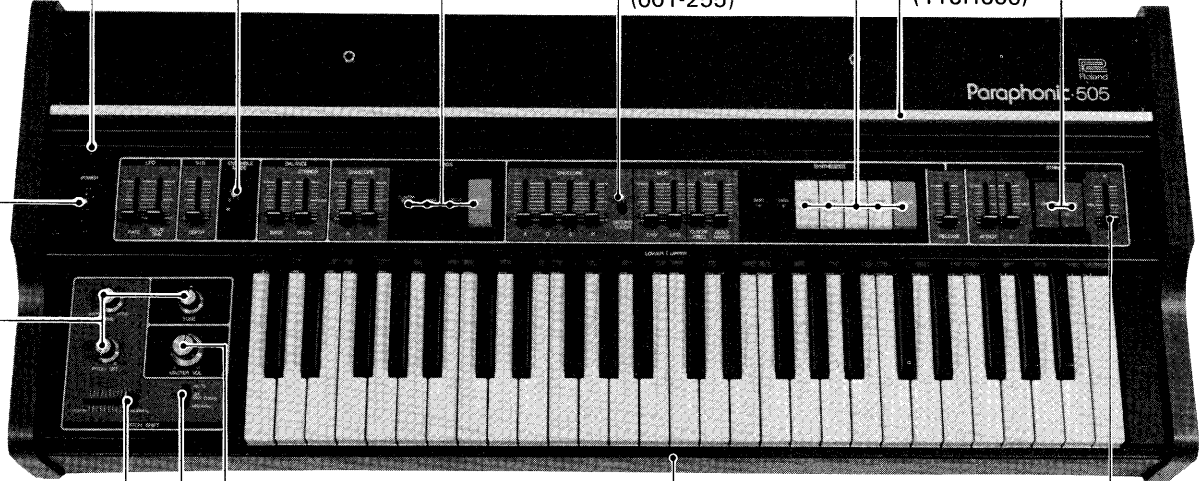

KNOB
TK-1114
(016-021)

KNOB
TK-1113 (016-026)

BLIND H. 40 (065H040)

KNOB NO. 33
(016-033)

LEVER SWITCH
SLE643-15P
(001-256)

KNOB NO. 33
(016-033)

GM10AK10 10KB
(028-1077)

Hinge H8
(059H008)

SSB-023-6RS
(001-183)

Chassis H68
(061H068)

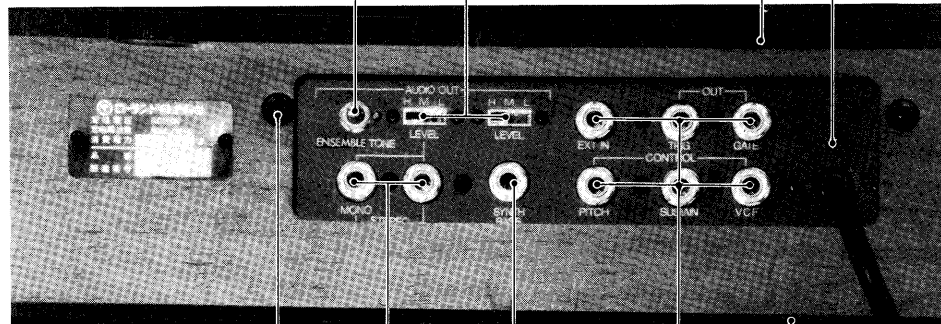

4x20
Oval

Jack
HLJ-102-1-1
(009-015)

Rubber Foot G-5
(111-021)

Jack
HLJ-027-01-080
(009-042)

PARTS LIST

081H170	Cabinet H170
059H008	Hinge H8
111-021	Rubber Foot G-5
081H171	Side Block H171 left
081H172	Side Block H172 right
072H041	Panel H41 upper
068-018	Bushing No. 18 music rack
110H006	Rail H6 music rack
004-010	Keyboard SK-192A
065H040	Blind H40
016-026	Knob TK-1113 large
016-021	Knob TK-1114 small
016-033	Knob No. 33 Slide
009-015	Jack HLJ-102-1-1
009-042	Jack HLJ-027-01-080 Bass Synth
022-110C	Power Transformer No. 110C 100/117V
022-110D	Power Transformer No. 110D 220/240V
022-129	Coil RC-855 osc 180 μ H
008-041	Fuse MGP0001 1A pigtailed w/CSA or UL marking 117V
008-066	Fuse SEMKO 1A midget prim. 220/240V
008-061	Fuse SEMKO 315mA midget sec. 220/240V
PCB ASSY	
149H028	OPH-28 (052H122)
147H009	GTH-9 (052H123)
147H010	GTH-10 (052H123)
147H011	GTH-11 (052H124)
151H007	ETH-7 (052H128)
155H001A	ARH-1A (052H125A)
153H002A	VCFH-2A (052H126A)
158H002A	LFOH-2A (052H127A)
149H029A	OPH-29 (052H129)
146H028C	PSH-28C (052H130C) 100V
146H029C	PSH-29C (052H130C) 117V
146H030C	PSH-30C (052H130C) 220/240V
ICs	
020-156	AY30214
020-051	TC4001P
020-158	TC4042P
020-090	TC4051P
020-157	TC4532P
020-076	TC4024P
020-041	TC4013P
020-161	TA7179P
020-064	μ PC4558C
020-096	BA662
020-160	BA662-A
020-162	SAD512 BBD
TRANSISTORS	
017-131	TN41A PUT
017-064	2SA495TM-GR
017-022	2SB434-O
017-010	2SD234-O
017-130	2SC381-R
017-129	2SC752G-O
017-106	2SC1815-GR
017-016	2SK30A-GR FET
DIODES	
018-086	SVC303 varicap
018-014	1S2473
018-081	1B4B41 bridge
019-027	TLR102KB LED
POTENTIOMETERS	
028-1077	GM10AK10B14 w/click
028-1068	JM40AK35B14 4-ganged
028-1058	VM60ZK30B24 20KB
028-1059	VM60ZK30B54 16 ϕ pc terminal
028-1054	VM60ZK30A55 500KA
029-459	LFE3RC20B14 slide ENV (from A curve to B)
029-461	LFE3RC20B54 50KB
029-462	LFE3RC20B15 100KB
029-449	LFE3RC20A54 50KA
029-453	LFE3RC20A16 1MA
029-472	LFE3RC16B15L 100KB
030-465	SR19R 10K Trimmer
030-459	SR19R 1K
030-469	SR19R 47K
SWITCHES	
001-183	SSB0236RS slide 2-pole 3-pos.
001-255	SLE622-23P lever 2-pole 2-pos.
001-256	SLE643-15P lever 4-pole 3-pos.
001-257	SLE623-23P lever 2-pole 3-pos.
001-258	SDA 1S A1 power 100V seesaw
001-260	SDE 4S A1 power 220/240V
001-259	SDA 2S A1 power 117V
002-004	SMT029A tablet STRINGS
002-005	SMT049A tablet BASS
002-006	SMT079A tablet SYNTH
003-010	Tablet green
003-011	Tablet maroon
003-012	Tablet white
003-013	Tablet gray
OTHERS	
048H012	Heatsink H12
064H200	PCB holder DLC BS-6N PSH
068-029	Collar Bush NA-305 PCB
068-034	Collar Bush NB-300 PCB
035-145	Capacitor ECQS5500J 50pF styrol
035-158	Capacitor ECQS1181JZ 180pF Styrol
045-005	Resistor array RM-6 334J 330K x6

KEYBOARD PARTS

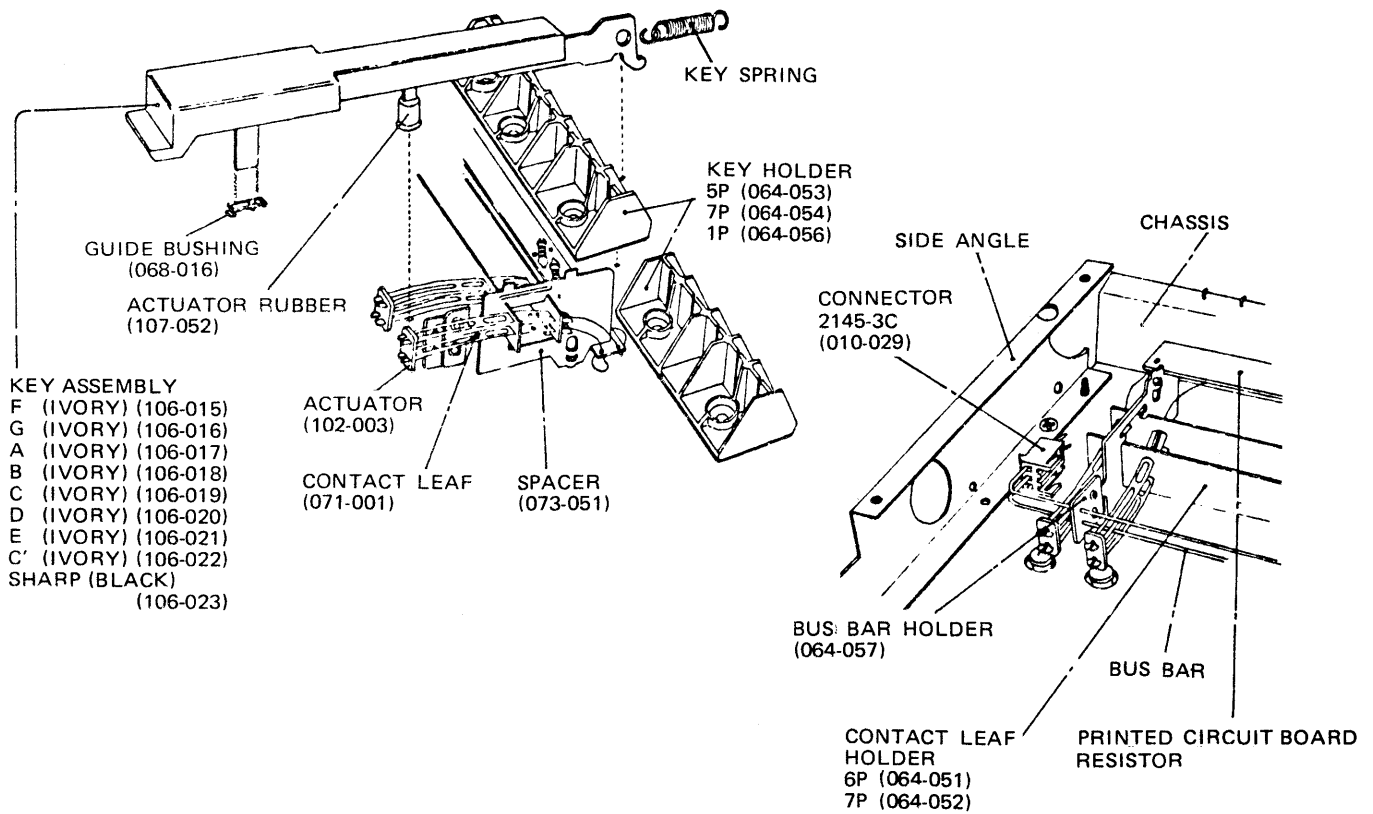

INSTRUMENT MODEL	NO. OF KEYS	KEYBOARD MODEL	KEY SPRING	BUS BAR	PCB		RESISTOR
					6P	7P	
SH-1	32	SK-132-D	070-052	071H034	052-066	052-067	100 1/4W $\pm 1\%$ CRB1/4FX
SH-3A	44	SK-142-A	070-052	071-008	052-066	052-067	100 1/4W $\pm 1\%$ CRB1/4FX
SH-5	44	SK-142-B	070-052	071-008	052-066	052-067	100 1/4W $\pm 1\%$ CRB1/4FX
SH-7	44	SK-142-C	070-052	071-008	052-066	052-067	100 1/4W $\pm 1\%$ CRB1/4FX
SH-1000	37	SK-132-A	070-052	071-006	052-066	052-067	1K 1/4W $\pm 2\%$
SH-2000	37	SK-132-B	070-052	071-006	052-066	052-067	1K 1/4W $\pm 2\%$ SELECTED
SYSTEM-100	37	SK-132-C	070-052	071-006	052-066	052-067	100 1/4W $\pm 1\%$ CRB1/4FX
SYSTEM-700	61	SK-162-C	070-058	071-007	052-066	052-067	100 1/4W $\pm 1\%$ CRA1/4FX
RS-101	61	SK-161-A	070-058	071-007	052-081	052-082	
RS-202	61	SK-161-A	070-058	071-007	052-081	052-082	
RS-505	49	SK-192-A	070-058	071H043	052-081	052-082	
EP-10	61	SK-162-A	070-058	071-007			
EP-20	61	SK-162-A	070-058	071-007			
EP-30	61	SK-162B	070-058	071-007	052-081	052-082	

MEMO