

SPV-355 SERVICE NOTES

● SPECIFICATIONS

SYNTHESIZER SECTION controls

Dual VCO (VCO-1, VCO-2)
 WAVEFORM Switch (\square \square \square)
 RANGE Switch (4', 8', 16')
 MASTER TUNING Control (± 250 cents)
 A TUNING Control (± 1200 cents)
 B TUNING Control (± 1200 cents)
 TUNING INDICATORS (A, B)
 VCO-1 SUB (1 octave down, \square)

PORTAMENTO Controls

PORTAMENTO Control (0-3s)
 PORTAMENTO ON/OFF

VCF Controls

CUTOFF FREQUENCY Control (10Hz-20kHz)
 RESONANCE Control (0 - self oscillation)

ENVELOPE GENERATOR Controls

ATTACK TIME Control (1ms-3.5s)
 DECAY TIME Control (2ms-7s)
 SUSTAIN LEVEL Control (0-100%)

CONNECTORS

Input and output

INPUT Jack
 OUTPUT Jack (input/output level = 1:1)

Second Printing MAY, 1984 E-2

REAR PANEL

CV OUT Jack (1V/oct)
 GATE OUT Jack (OFF: 0V; ON: +15V)
 ENV FOL'R OUT Jack (0-+10V)
 CV IN Jack (1V/oct)
 GATE IN Jack (Threshold: +3.8V)

Power Consumption: 13W

Dimensions:

482(W) x 92(H) x 350(D) mm
 Fits standard 19" rack (EIA-2U)

Weight: 5.7kg

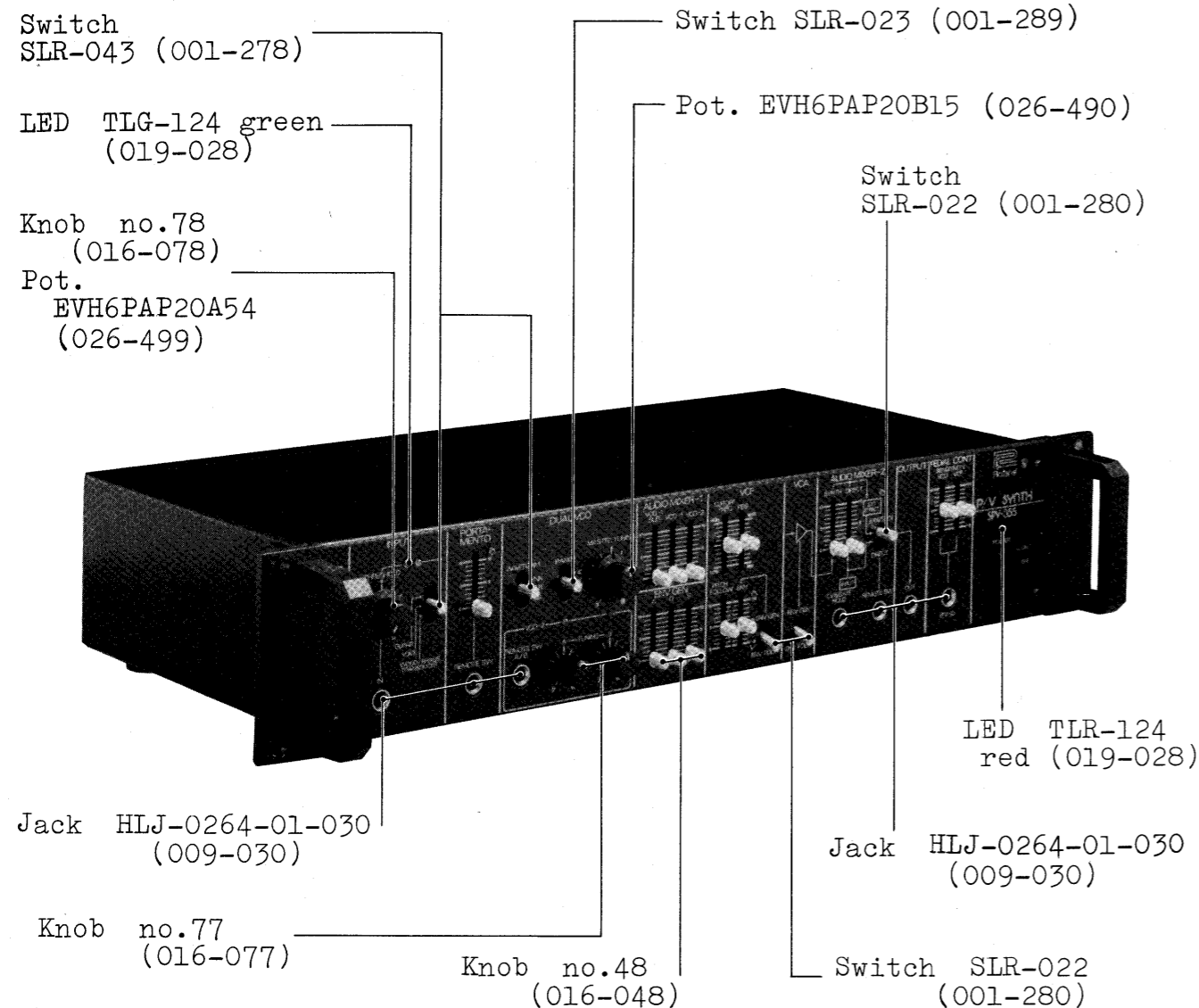

Switch

SDG5P001-1 100V (001-215)

SDG5P001-2 117V (001-216)

SDG5P-502 220/240V (001-217)

Button no.9 (016-009)

Panel no.282 (072-282)

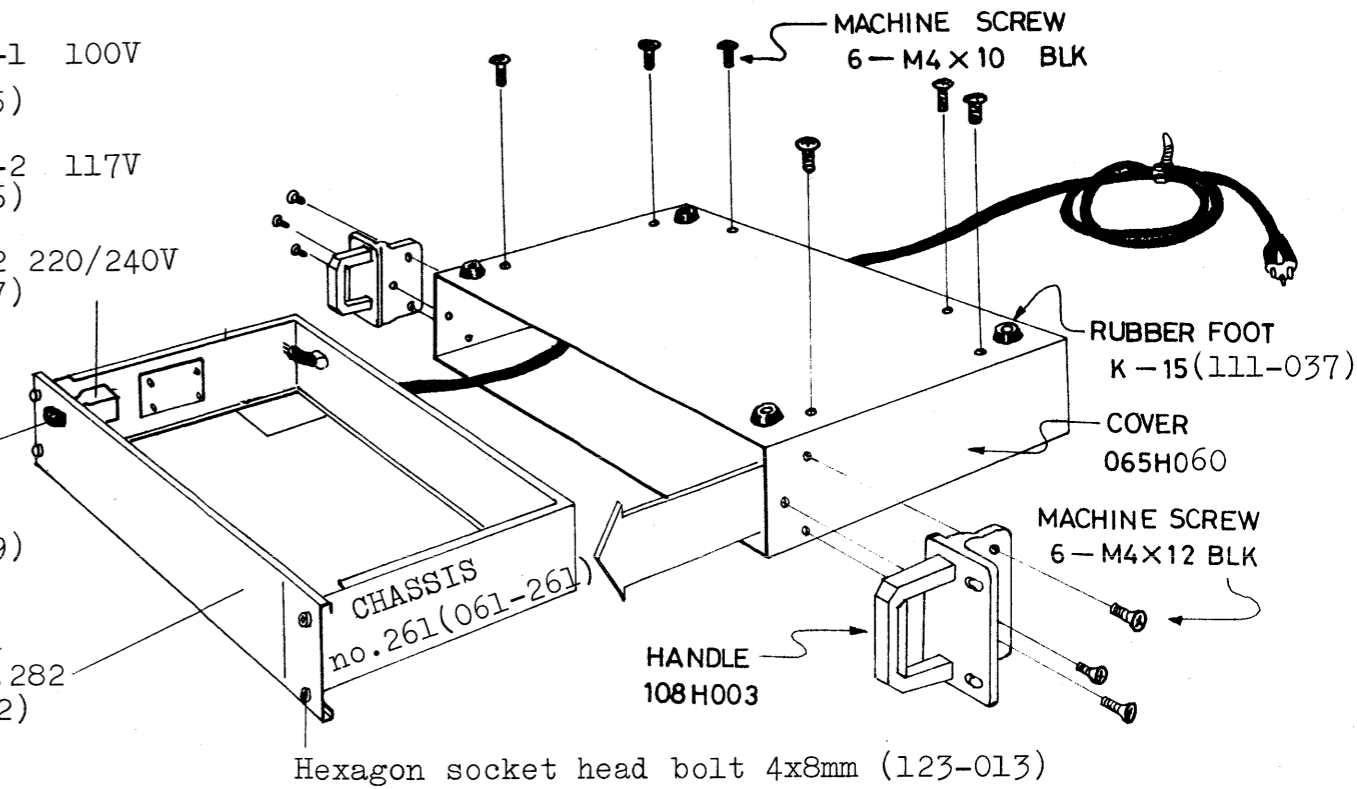
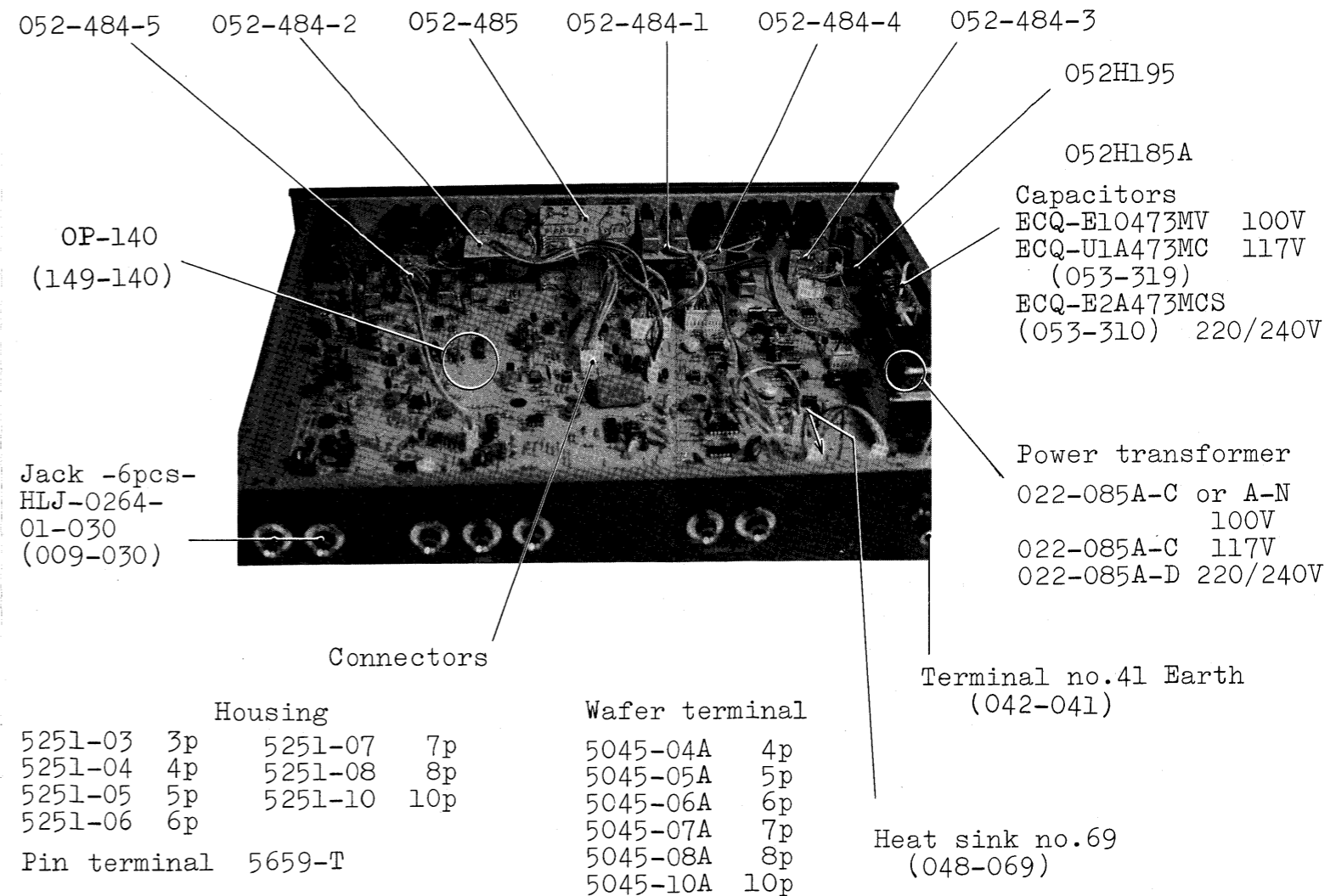

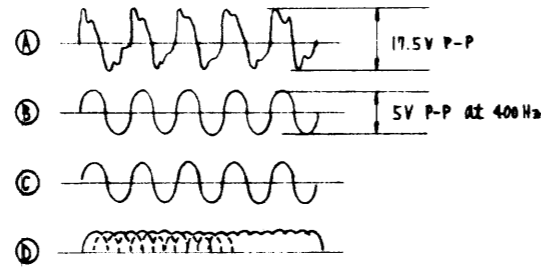
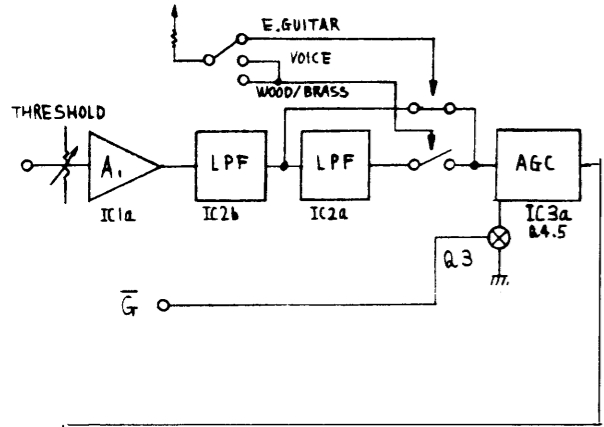
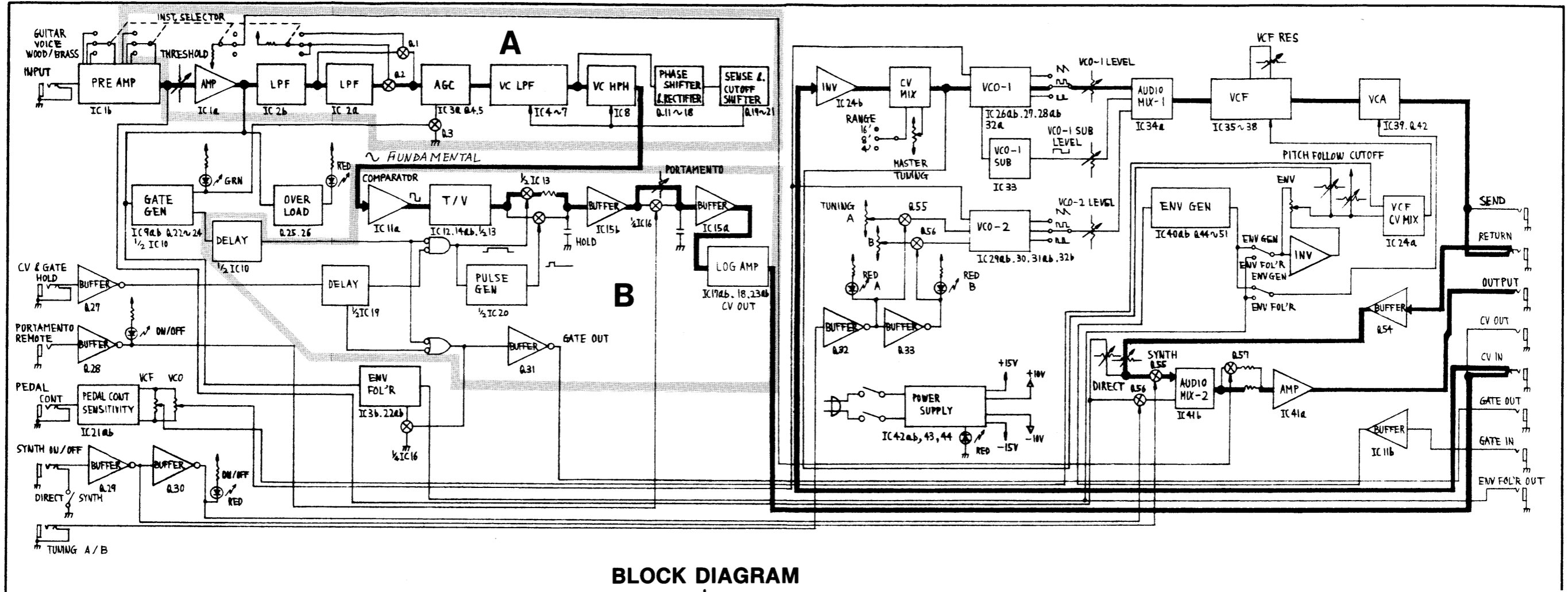

A

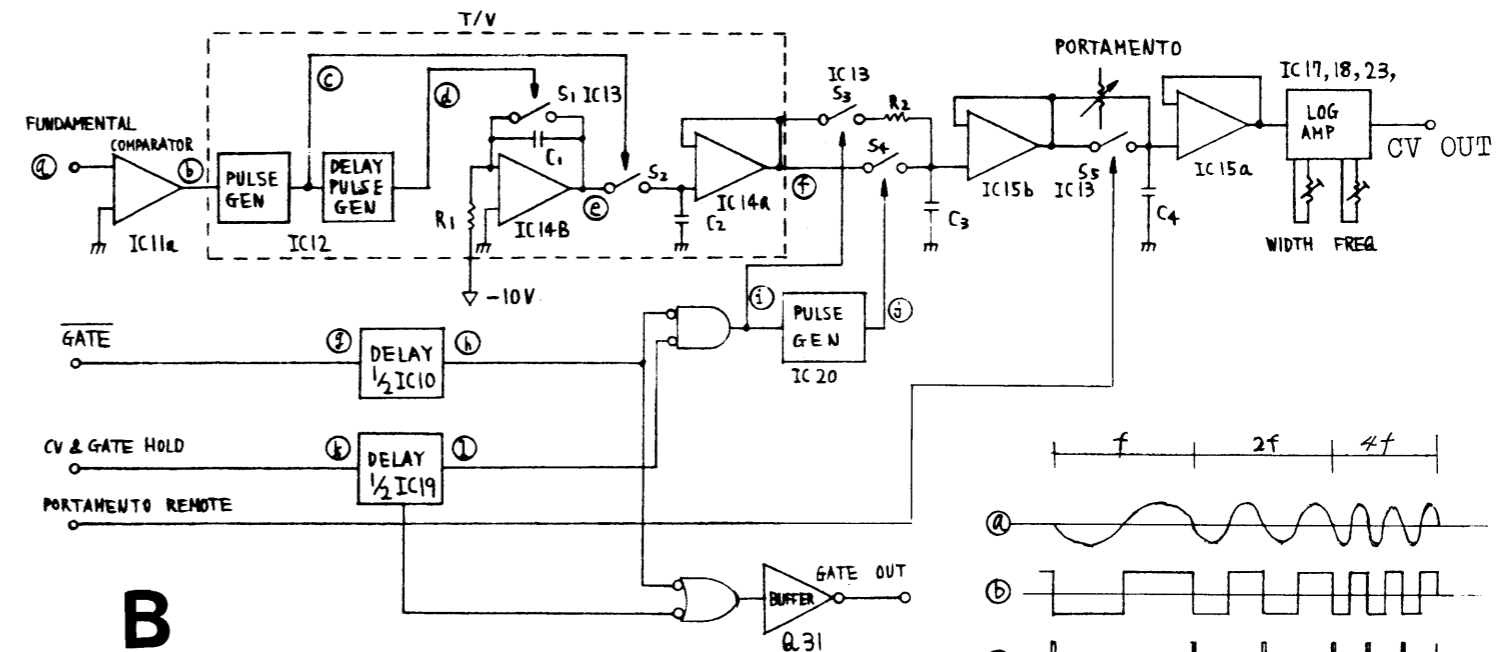
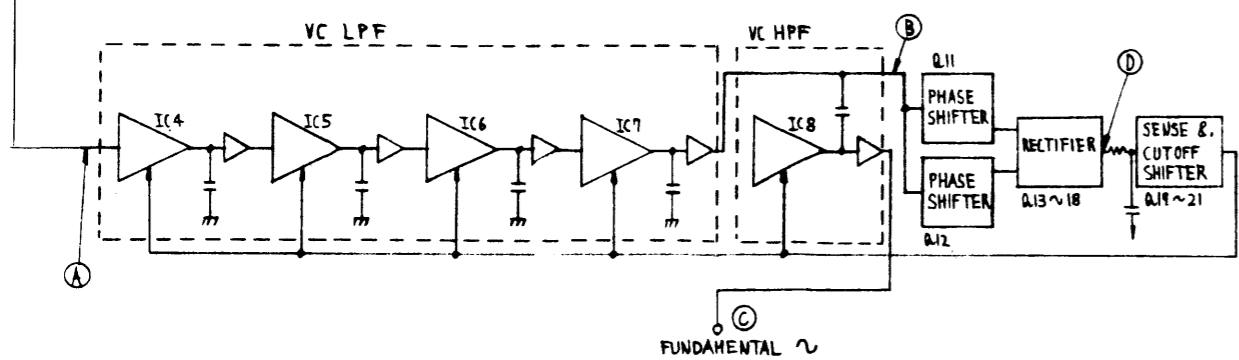

B

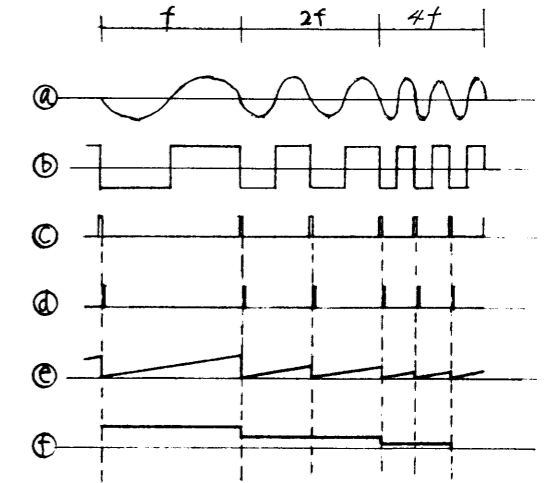

CIRCUIT DESCRIPTION

SPV-355, on its main portion, is divided functionally into: 1) the Pitch-to-voltage conversion section and 2) the Synthesizer section. The former is further sub-divided into these circuit groups:

1. Fundamental Detector
2. Time to Voltage (T/V) Converter
3. Logarithmic Converter
4. Gate Generator
5. Envelope generator

It is assumed that the reader has some knowledge on the synthesizers, and we would confine our devoted effort to those points alone that are particular to this SPV-355.

1. FUNDAMENTAL DETECTOR (refer to Block Diagram A)

Audio signals that are produced at some external musical instrument are partly fed to IC1b, IC1a for amplification.(the rest to direct out) They are then go through LPF (IC2b) to attenuate unwanted high frequency.

When INPUT SELECTOR switch is in WOOD/BRASS MODE, there is one more stage of LPF (IC2a) that the signal has to go through.

After LPF, the signals are fed to the AGC (IC3a,Q4 and Q5)where they are put to a constant voltage level at about 17.5Vpp.

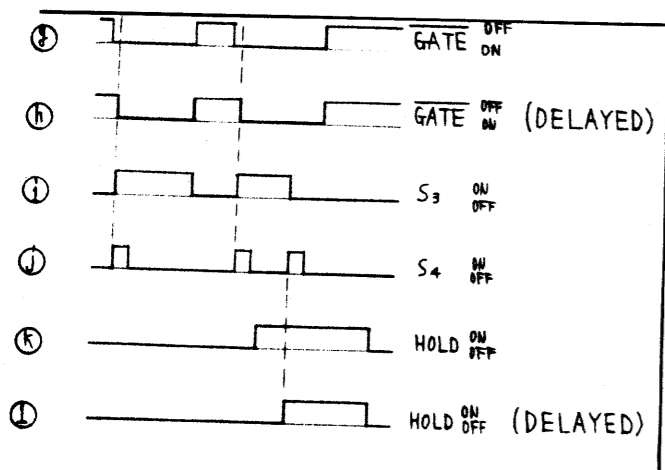

- Voltage Controlled Low Pass Filter (VC-LPF) & High Pass Filter (VC-HPF) -

These two filters constitute a band pass filter. They extract from input signal a fundamental tone alone while suppressing all other unnecessary high harmonics and low noises, etc.(see Fig.below)

- VC-LPF (IC4-IC7) -

They are all of the same type. The particular point here is that they are made to have such frequency response characteristic controllable so that the input signal falls always at 10dB down point on the slope of high frequency side of its characteristic curve. (We will further discuss how the frequency response band can be swept in accordance with in-coming signal frequencies in later section.)

This makes the passing signal amplitude reduced and it is now to about 1/3 of the input signal level, or to 5Vpp at 400Hz. On its result, almost all high frequency components can be removed to leave only the fundamental remained.

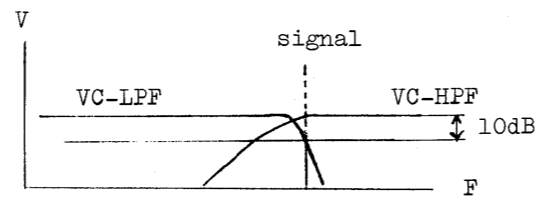

- VC-HPF (IC8) -

HPF here is to remove unnecessary and harmful contents of low frequency range below fundamental, such as vibration on strings of lower compass other than those being played on a guitar, or, noises produced while handling instruments, or, line frequency pick-ups or hums, etc.

- Filter Controlling Current - Quadrature Phase Shifter Quadruple Rectifier Cutoff Shifter

They together form a feedback loop in the VC-LPF. The purpose is to provide a system in which the frequency response range of the band pass filter is moved as input signal varies frequencies.

Suppose that, the incoming signal has changed its frequency to deviate, on the characteristic curve, from the previously adjusted 10dB down point. If it were to higher frequency side the filter output should be reduced in amplitude, or if it were to lower side output be increased. Such change on output is detected by the system as above which then produces control current to feed from Q21 to VC-LPF Filter to adjust itself to always meet the incoming signal frequency at the 10dB down point on its response curve.

Quadrature Phase Shifter (Q11,Q12)

Q11 and Q12 are the constant gain shift circuits, each having a capacitor for phase shift.

The phase difference between two output signals is 90° in the range 60Hz-600Hz. (Fig. "B", "C")

Quadruple Rectifier (Q13-Q18)

The two waves having 90° phase difference are further subdivided here through Q13, Q14 into waves having phase differences 0°, 90°, 180° and 270°. When they are further half-wave rectified through Q15-Q18, the resultant wave shape of all combined becomes so much dense and closely crested one even in low signal frequency ranges. (see Block Diagram A, Fig. "D") This means that the time constant of the ripple suppressing RC circuit(R89 C34) can be small and, in turn, changes in VC-LPF output are quickly mirrored on the rectified waves even in the low frequency range.

D4 and D5 are for limiting the pulsating voltage.

Cutoff Shifter (Q19-Q21)

Q21, sensing whether rectifier output voltage is more or less in comparison with the reference voltage (to be determined by VR-6), outputs control voltage corresponding to its detection to feed it to Q21 which converts this voltage into current and feeds it to VC-LPF and HPF.

R95 assumes a minimum current to compensate for no controlling current when Q21 has been cutoff.

2. TIME to VOLTAGE CONVERTER (refer to Block Diagram B)

At the comparator (IC11a) the fundamentals (a) are converted to rectangular waves (b). They then go through the pulse generators (IC12) to generate pulses (c) and (d). Between them, (d) lags behind (c) by about 4μs.

Voltage (e) increases in positive going direction at the rate determined by R1C1 time constant. It is reset and turned to 0V every time S1 is closed by (d). Here (d) synchronize with the input signals. The intervals between pulses in (d) are becoming longer as the frequency goes higher. Accordingly, potential of (e) decreases as the input signal increases in frequency. S2 is in the meantime, switched on by the pulse (c). During the interval between (c) and (d) (of 4μs), (e) is sampled out. The sampled voltage is almost the highest voltage level (e) has reached before it is re-set to 0V by (d).

IC14a on the next stage is a low-leak voltage follower. It outputs (f) in the same voltage level that was charged at C2.

S3 is gated by (i), and conveys (f) to IC15b. The voltage variation here lags behind the variation in input signal due to the R2, C3 time-constant. (more about these R2 and C3 discussion will be later.)

To reduce detrimental effect results from this, S4 is provided to be closed by the pulse (j) which is generated on the trailing edge of the delayed GATE. It is to make the circuit equivalent as having R2 being shorted. In practice, (i),(j) occur exactly at the same time but with a little delay behind the trailing edge of GATE, as can be seen on the waveforms illustrated.

This is in order to eliminate unstable pitch in the initial part of the musical sound where also tended are other sounds to be included than its own during the transient.

R2 and C3 are filter which smooth the undulating voltage in the same pitch in(f) output. The reason for the occurrence and its adverse effect are as follows:

Although (a) is the fundamental, it is not at all an ideal sine wave but somehow distorted by noises, or hums, etc. When these have effect on (c) and (d), the same would also appear on (f). When the synthesizer is set at the higher range, it would cause its sound output to become muddy.

- HOLD -

When HOLD ON is set, (i) becomes OV, S3 is to open and the output of (f) is disconnected from C3. Although (l,-L-) -together with this, the trailing edge of (i)- lags behind (k), this is to help avoiding undesired sound, which comes in before the desired sound, becomes HELD ON when the switching timing happened to be too early.

3. LOGARITHMIC CONVERTER

As in common, SYNTH Section of SPV-355 is controlled by CV (control voltage) of logarithmic in the rate of 1V/oct. However, so far the output of fundamental through T:V circuit is simply a linear. There is therefore a need to convert this to such CV to suit for controlling SYNTH. When from T/V output the log curve output is obtained, it becomes possible to control SYNTH in such a way that having 1V change is to have VCO frequency doubled or halved on SYNTH section.

To express this in mathematical formula is:
 $F = 1/T$ or, $VF = 1/VT$ (constant is omitted for clarity). Therefore,
 $CV = \log VF = \log 1/VT = \log 1 - \log VT = 0 - \log VT = - \log VT$

This conversion is performed through IC17a,b and IC18. As is seen, the VT here is inverted. It is because that the output of T/V is reverse proportional to the frequency of the input signal.

4. GATE GENERATOR

GATE Generator consists of IC9a,b, Q22,23 and 1/2 IC10.

RS flip-flop (1/2 IC10) is set by the signal from IC9a when it turns to "H", GATE ON. The F-F is reset when Q23 (C39) turns to "H" (approx. 7.5V or more), GATE OFF.

Signal from IC1 is fed to the (-) pin of IC9a. When this negative half becomes lower than that on the (+) pin (negative) determined by R102, R103, IC9a output becomes "H". It is fed to IC10 pin 8, and causes G output to become "H". It sets at the same time the green light of LED (D11) being lit to indicate the GATE ON. When the input level at this (-) pin of IC9a goes positive with respect to the (+) pin, the output of IC9a turns to L, but IC10 still holds G terminal at H.

Q23,C39 are the quasi-sawtooth wave generator. The voltage charged at C39 through VR-2 and R101 is discharged every time Q23 conducts at the input signal frequency rate. IC10 is reset when this wave peak reaches H (1/2 VDD). There are two possible occurrences for this to become H.

(1) When the signal frequency turns to low: With its intervals between positive-going pulses at Q23 base becomes longer, more charging current into C39 through VR-2, R102, which in turn makes the wave more positive. In practice it is adjusted by VR-2 to turn to H at the frequency range of 65Hz or lower.

(2) When the signal level decreases: It also decreases the voltage level fed to Q23 base, not enough for Q23 to conduct. As a result, C39 does not discharge but continues its charging so as to obtain higher voltage level and becomes H.

As can be seen from the figure right GATE signal turns on/off at the different musical signal levels. As for turn-off level, there is another trick to meet sudden input signal variation in amplitude. Suppose that, when a guitar play is suddenly stopped by depressing strings, gate signal must turn off, before the signal level drops to predetermined normal "off" point A, to shut off being sustained non-musical sounds.

IC9b is such that it incorporates Q22 in parallel with R97 in its feedback loop. Since the impedance of Q22 (C-E junction) increases in reverse proportion to the input, the circuit in this configuration can be regarded as an AGC circuit.

When the IC9b output voltage increases above 1.2V (forward voltages: D9, Q22 B-E junction), the current flows through Q22. It makes the C-E resistance decrease, to decrease therefore in the gain of IC9b. Total effect is to maintain the output in constant level, approx. 1.2V.

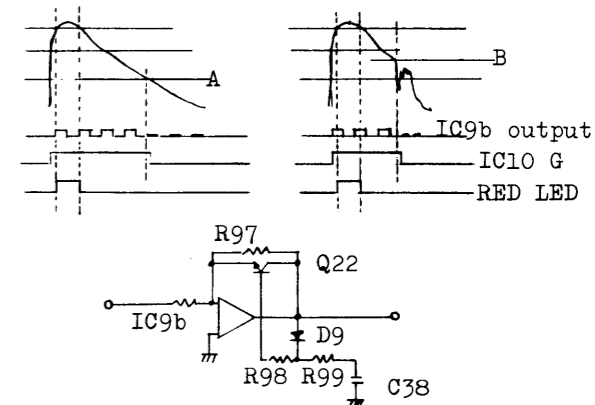

On the illustration as above, let's suppose firstly that the sounds drop at a slow rate. The output decreases, and Q22 base voltage and the current flow through it both decrease too. It makes the impedance in sum with R97 increase, and with it, the gain of IC9b is increased. If, however, the sound drop is so sudden, there would appear a certain delay in decreasing the base voltage of Q22. It is because of the time constant of R98,99 and C38. While held there, the gain of IC9b does not increase. With no change in gain here, the output too drops suddenly as the signal decays to point B.

5. ENVELOPE FOLLOWER

IC3b,22b are a full-wave rectifier. The pulsating wave from there are further flattened out while passing through the filter (IC22a) to become an output that follows very similar envelope to that of input signal.

1/4 IC16 is an analog switch which is turned on-off in response to the GATE signal. The switch is to prevent unnecessary prolongation on the output of the ENVELOPE FOLLOWER which occurs due to the filter circuit time constant. Here, pin 4 of IC16 is not directly grounded but slightly biased at negative. This is only because that the circuits including the other IC16s are requiring negative source. So far as this switch is concerned, however, it can be regarded as equivalent to a direct grounding.

PARTS LIST

		SEMICONDUCTOR		POTENTIOMETER		CAPACITOR	
072-282	Panel no.282		Transistor		Rotary		Bi-polar
065H060	Cover (case) H60	017-016	2SK30ATM-GR FET	026-490	EVH6PAP20B15 100KB TUNE	032-190	ECEA50N1 1mfd 50V
108H003	Handle H3	017-107	NF510 FET	026-499	EVH6PAP20A54 50KA	032-241	ECEA16N10 10mfd 16V
111-037	Rubber foot K-15	017-103	2SK117-GR FET		Slider	032-244	ECEA25N10 10mfd 25V
061-261	Chassis no.261	017-106	2SC1815-GR				Tantalum
	KNOB	017-105	2SA1015-Y	029-592	EVAHHPS20B15 100KB		
016-009	Button no.9 black power switch	017-116	2SA1015-GR	029-603	EVAHHPS20A15 100KA	032-224	1mfd 35V
016-048	No.48 slider		Diode	029-607	EVAHHPS20A26 2MA	032-226	2.2mfd 35V
016-077	No.77 rotary small	018-078	1S2453	029-606	EVAHHPS20A16 1MA	032-227	3.3mfd 35V
016-078	No.78 rotary large	018-014	1S2473	029-609	EVAHH7S20B15 100KB w/center -tap -click		Polypropylene film
	SWITCH	018-082	W-02 bridge rectifier		Trimmer	035-091	ECQF2334MZ 0.33mfd
001-215	SDG5P001-1 power 100V	018-015	SDT-1000 thermistor	026-004	EVTR4AAB14 (SR19R) 10KB		Polystyren film
001-216	SDG5P001-2 power 117V	019-028	TLR-124 red LED	026-007	EVTR4AAB15 (SR19R) 100KB	035-279	ECQS1102KZ 0.001mfd 10%
001-217	SDG5P-502 power 220/240V	019-029	TLG-124 green LED	026-008	EVTR4AAB25 (SR19R) 200KB	035-321	ECQS1222KZ 0.0022mfd 10%
001-280	SLR-022 lever up-throw		IC	026-009	EVTR4AAB55 (SR19R) 500KB	035-274	ECQS1151KZ 150pF 10%
001-278	SLR-043 lever	020-097	µPC4558C dual op amp	026-491	CR19R 2KB	035-097	ECQS1102JZ 0.001mfd 5%
001-279	SLR-023 lever	020-153	NJM4559 high slew rate op	026-495	CR19R 10KB metal film		
	POWER TRANSFORMER	020-100	TL082CP FET dual op amp	026-499	CR19R 47KB		
022-085A-C	No.85A-C 100/117V	020-208	LF353N FET dual op amp	026-501	CR19R 100KB		
022-085A-D	No.85A-D 220/240V	020-108	µA7815UC regulator				MESCELLANEOUS
	FUSE HOLDER. FUSE	020-110	µA7915UC regulator	030-630	PN822H202H 2KB metal	042-041	Terminal no.41 earth
008-026	SGA0001 1A 100/117V	020-032	µA726HC	030-632	PN822H502H 5KB film	065-262	Cover (dust cover)no.262 PORTAMENTO CONT.
008-064	CEE T500mA 220/240V	020-169	MC14001BCP	030-629	PN822H102H 1KB cubic	065-263	Cover no.263 w/10 slits
012-003	Clip TF-758	020-170	MC14011BCP			065-264	Cover no.264 MIXER-2 Pedal cont.
	PCB	020-210	MC14066BCP		RESISTOR	001-015	Long(sleeve)nut no.15 3x12mm
149-140	OP-140 (052-483)	020-179	MC14013BCP	044-830	CRB25FX 1K ¼w selected	048-069	Heat sink no.69
052-485	AUDIO MIXER-1	020-160	BA662A	044-846	CRB25FX 100K ¼w selected	065-261	Cover no.261 lever
052-486-	1, 2, 3 LED Mounting	020-096s	BA662Bs selected VCF				
052H195	LED Mounting		Replace exist BA662B with only one dotted in the same color.		When replacing, replace all resistors in the affected group with 1% resistors which have been tested and are within 0.1% of being identical in value. (refer to Printed Wiring Layout)		
052H185A	Prim. Fuse Mounting						
052-484-	1,2,3,4 Pot.Mounting						
* 052-xxx	means PCB only.						
	Add word "assy" when ordering assembled one.						

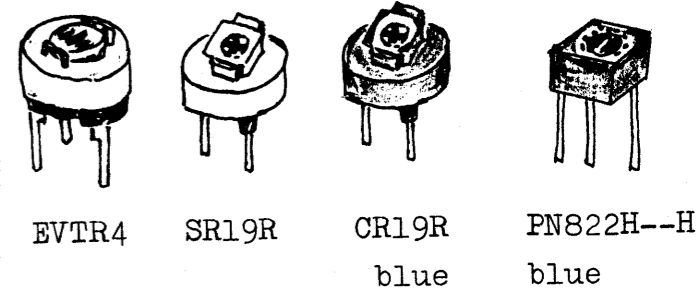

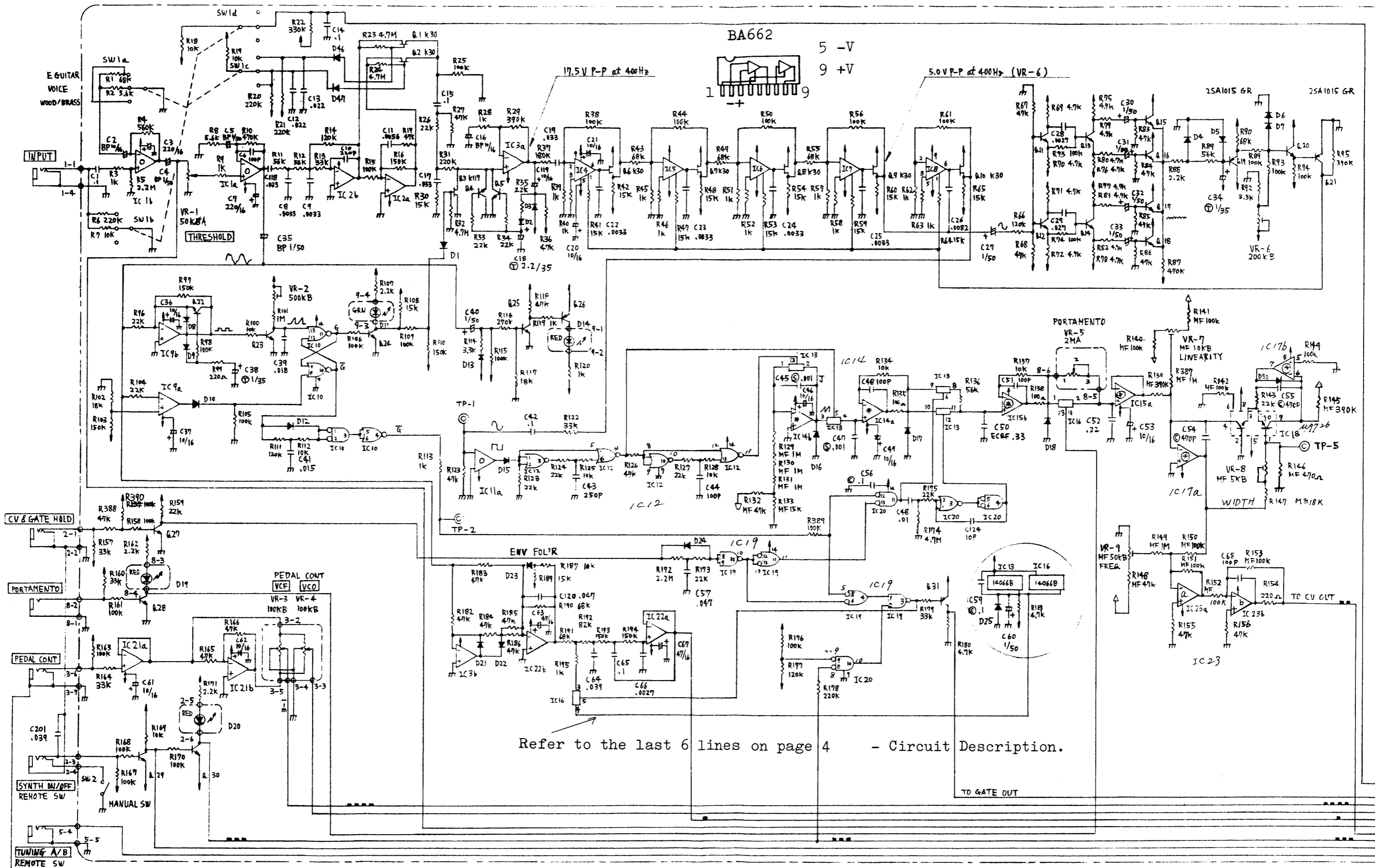

Refer to the last 6 lines on page 4 - Circuit Description.

IC:
 IC15 - LF353N selected (yellow)
 IC14 - TL082CP only
 IC17,28,31- LF353N or TL082CP
 or (LF353N selected)

MC14066BCP
 can be substituted
 by CD4066BE or
 HP14066BP

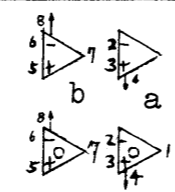

μPC4558C
 JRC4559DD

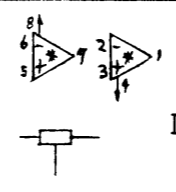

TL082CP
 MC14066BCP

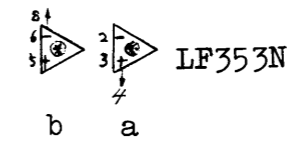

Transistor:
 NPN -2SC1815-GR
 PNP -2SA1015- Y or GR
 Q19, Q21 - GR only
 Q49 - Y only

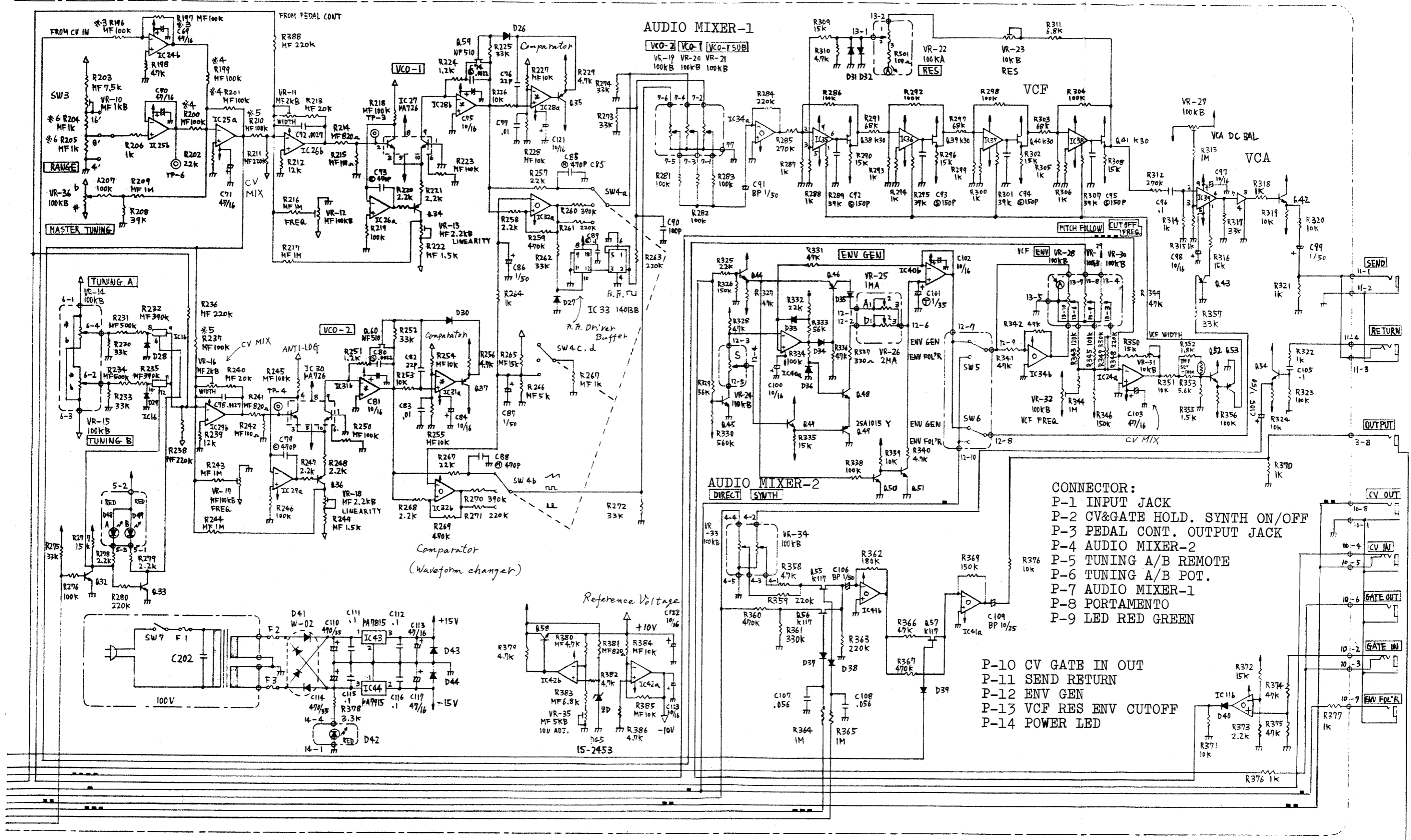

FET:
K30 - 2SK30A-GR
K117 - 2SK117-GR

Diode:
Not specified- 1S2473
LED(red) - TLR-124
LED(GRN) - TLG-124

Capacitor:
(S) - Polystyrene
(C) - Ceramic
(M) - Mylar

SW1- INPUT SELECTOR
SW2- SYNTH ON/OFF
SW3- RANGE
SW4- WAVEFORM
SW5- VCF MOD ENV GEN/FOL'R

SW6- VCA
ENV GEN/FOL'R
SW7- POWER

PCB 052-484-4

AUDIO MIXER-2

DIRECT SYNTH

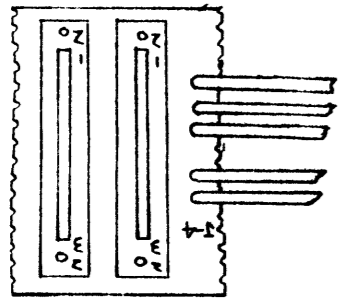

VR-33 VR-34
EVAHHPS20B15 (029-592)

PCB 052-484-1

ENVELOPE GEN/FOL'R

VCA VCF

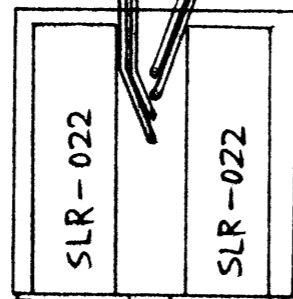

SW6 SW5
SLR-022
(001-280)

PCB 052-484-3

PEDAL CONT
SENSITIVITY

VCF VCO

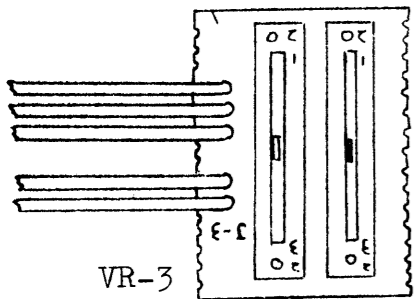

VR-3 VR-4
EVAHH7S20B15 (029-609)

PCB 052-485

VCF

PITCH FOLLOWER
VR-29
EVAHHPS20B15
(029-592)

ENV VR-28
EVAHH7S20B15
w/center tap
(029-609)

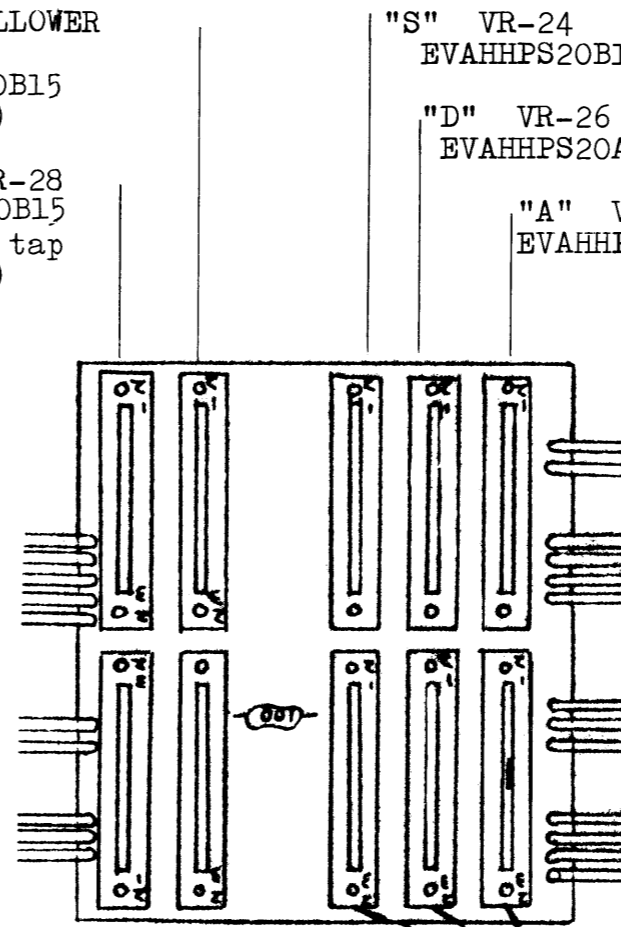

RES. VR-23
EVAHHPS20A15
(029-603)

CUTOFF FREQ. VR-30
EVAHHPS20B15
(029-592)

VCF

ENVELOPE GENERATOR

"S" VR-24
EVAHHPS20B15 (029-592)

"D" VR-26
EVAHHPS20A26 (029-607)

"A" VR-25
EVAHHPS20A16 (029-606)

VCO-1 SUB VR-21
VCO-1 VR-20
VCO-2 VR-19
EVAHHPS20B15 (029-592)

AUDIO MIXER-1

PCB 052-185A

Fuse holder
TF-758 (012-003)

Fuse SGA0001A
(008-026) 100/117V
CEE T500mA
(008-064) 220/240V

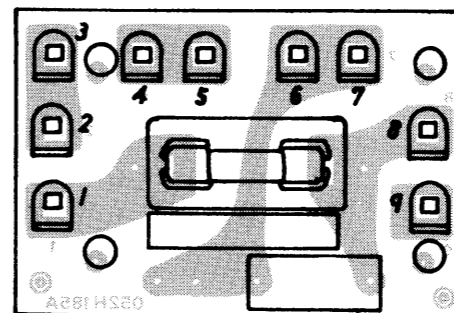

PCB 052-484-2

VCO-2 TUNING

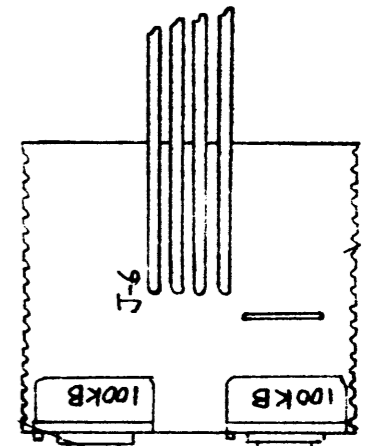

"B" VR-15
"A" VR-14
EVH6PAP20B15 (026-490)

PCB 052-484-5

PORTAMENTO

EVAHHPS20A26
(029-607)

VR-5

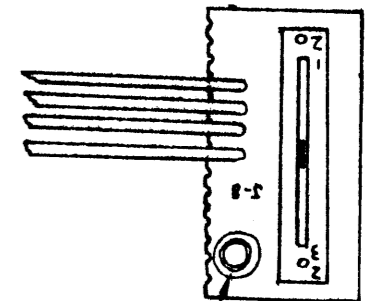

LED TLR-124
(019-028)

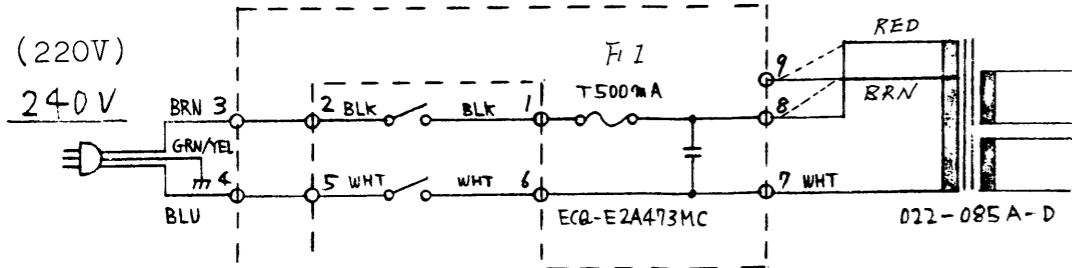
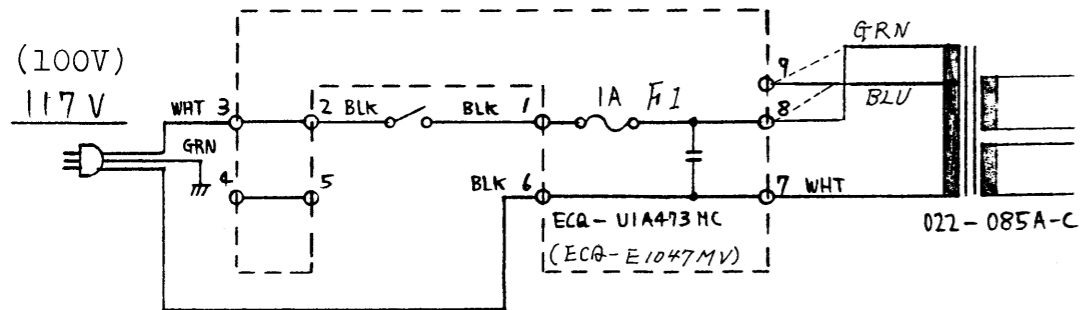

TL082CP

LF353N selected (yellow)

*:Factory selected Components in a unique serial no. have almost the same characteristic or value. When replace, BA662- in the same color - Resistor- two or three together.

052-483

SPV-355

OP-140(149-140)

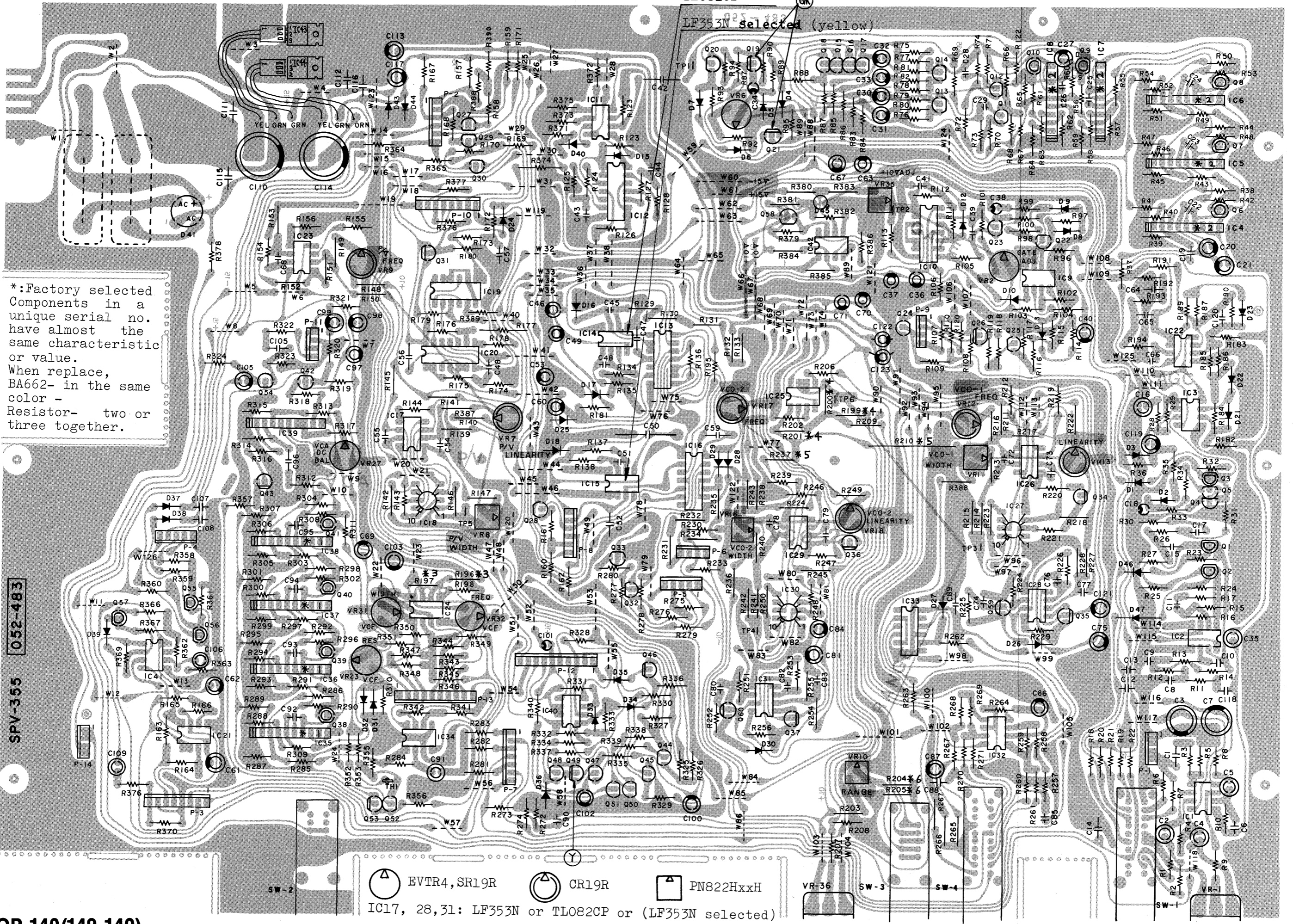

EVTR4, SR19R CR19R PN822HxxH SW-2 SW-3 SW-4

IC17, 28, 31: LF353N or TL082CP or (LF353N selected)

SHEET of ADJUSTMENT

ADJUSTMENT

ADJUSTMENT and CHECKING should proceed in the order listed below; accurate adjustment of each section depends on preceeding adjustment.

- | | |
|-----------------------|--------------------|
| 1. DC SUPPLIES | 6. TIME to VOLTAGE |
| 2. RANGE PRESET | CONVERTER |
| 3. INPUT LEVEL | 7. VCOs |
| 4. GATE GENERATOR | 8. VCF |
| 5. VOLTAGE CONTROLLED | 9. VCA |
| FILTERS | 10. OUTPUT LEVELS |

CAUTION

Allow about 15 minutes for a warmup.
Keep room temperature stable during servicing SPV-355.
Do not expose the SPV-355 being adjusted to the direct heatings and coolings since P/V, VCO and VCF circuits are temperature sensitive.

NOTE

Replacing a particular IC with a new one will involve re-adjustment of the following trimmerpot(s) pertaining to that circuit.

IC replaced	Pot. to be readjusted
IC10	VR-2 GATE GEN.
IC12 IC13 IC14 IC15 IC17	VR-7 P/V LINEARITY
IC18	VR-7 P/V LINEARITY VR-8 P/V WIDTH VR-9 FREQ.
IC27	VR-11 VCO-1 WIDTH VR-12 VCO-1 FREQ. VR-13 VCO-1 LINEARITY
IC30	VR-16 VCO-2 WIDTH VR-17 VCO-2 FREQ. VR-18 VCO-2 LINEARITY
IC39	VR-27 VCA DC BAL.
IC42	VR-35 10V ADJ. VR-7 P/V LINEARITY VR-8 P/V WIDTH VR-9 P/V FREQ.

With some adjustments, interaction takes place between or among adjustments, or certain effects are brought to other adjustments. In the list below, "AS" indicates associate VR(s) and "E" indicates affected VR to be readjusted.

DESIGNATION & TRIMMER POT.	WHAT IS ADJUSTED	REMARK
GATE GEN VR-2	GATE CUTOFF FREQ.	
FUNDAMENTAL VR-6	VC-LPF 10dB DOWN POINT FREQ.	
P/V LINEAR. VR-7	CV LINEARITY at HIGH FREQUENCY	AS - VR-8
P/V WIDTH VR-8	CV 1V/OCT CONVERSION	AS - VR-7 E - VR-9
P/V FREQ. VR-9	CV = 0V at E 32 FEET	E - VR-12,-17
RANGE VR-10	RANGE PRESET	
VCO-1 WIDTH VR-11	1V/OCT OUTPUT	AS - VR-12, -13 E - VR-12
VCO-1 FREQ. VR-12	32' E PITCH with 0V CV INPUT	
VCO-1 LINEAR. VR-13	DEVIATION at HIGH FREQUENCY	AS - VR-11
VCO-2 WIDTH VR-16	1V/OCT OUTPUT	AS - VR-17, -18 E - VR-17
VCO-2 FREQ. VR-17	32' E PITCH at 0V CV INPUT	
VCO-2 LINEAR. VR-18	DEVIATION at HIGH FREQUENCY	AS - VR-16
VCF RESONANCE VR-23	OSCILLATION INITIATIVE POINT	
VCA DC BAL. VR-27	CLICK REDUCTION	
VCF WIDTH VR-31	1V/OCT CUTOFF	E - VR-32
VCF FREQ. VR-32	CUTOFF FREQUENCY	
+10V VR-35	REFERENCE VOLTAGES	E - ALL P/V & VCOs

TEST POINTS (TP-**) and ADJUST TRIMMERS are red printed on Printed wiring assembly drawing on page 9.

1. DC SUPPLY

Connect Digital Meter to		Reading (within the range of)
W60	check	-14.25V to -15.75V
W61	check	+14.25V to +15.75V
W66	adjust VR-35 for	+10V ± 0.001V
W67	check	-9.800V to -10.200V

2. RANGE PRESET VOLTAGE

Connect Digital Meter to	RANGE	READING
Set RANGE switch at 4'.	4'	0.00X
Note the reading (call this X).	8'	1.00X ±1mV
Adjust VR-10 for the voltages	16'	2.00X ±1mV

in the table right with the switch set at proper position.

3. SIGNAL LEVELS vs LED ON/OFF TIMING

As can be seen from the figure right input signal versus green LED on/off GATE signal has non-linear hysteresis characteristic. Once green LED lights, it will stay on until the signal decays at point "C".

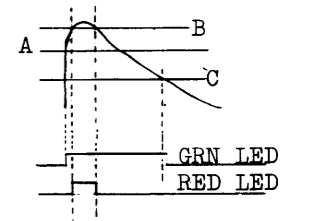

Check input signal levels for the figures of table below at 400Hz sine wave with THRESHOLD turned full clockwise.

INPUT Selector at GUITAR, WOOD/BRASS			
-56.5dBv	-54.5dBm	1.5mV rms	green LED ON
-38dBv	-36dBm	12.5mV rms	red LED ON
-82dBv	-80dBm	0.25mV rms	green LED OFF
INPUT Selector at VOICE			
-77.5dBv	-75.5dBm	0.4mV rms	green LED ON
-59dBv	-57dBm	1.1mV rms	red LED ON
unmeasurable			green LED OFF

- DIRECT LEVEL -

With 400Hz being input, check that OUTPUT jack's signal is equal to that at INPUT jack in amplitude in the following conditions:

AUDIO MIXER-2 Selector

MIX(S+D)	DIRECT
SYNTH knob at "0".	SYNTH knob anywhere
DIRECT knob at "5".	DIRECT knob anywhere

- AGC OUTPUT WAVEFORM, LEVEL -

With 400Hz square wave input into INPUT jack, connect an oscilloscope to R29 (IC3 pin 1). Screen will display waveforms similar to those in figures shown below when THRESHOLD is set just before red LED lights. While decreasing the input signal gradually, check that the waveform disappears from the scope at exactly the same time green LED goes out, or Q3 ceases to conduct.

INPUT SELECTOR

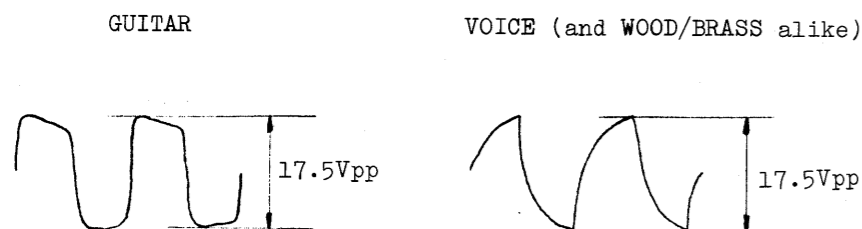

4. GATE GENERATOR

Feed a 65Hz square wave into INPUT jack (INPUT selector anywhere). Set generator and THRESHOLD knob for just before red LED blinking. Connect scope to TP-2. Adjust VR-2 for the narrowest pulse width.

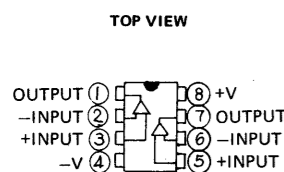

µPC4558C
NJM4559
TL082CP
LF353N

µA726

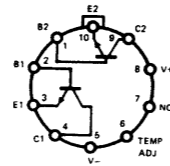

5. FUNDAMENTAL GENERATOR (VC-LPF CUTOFF)

Connect: 400Hz square wave into INPUT jack.
Scope to Q9 source.
Adjust VR-6 for 5Vpp at Q9 s.
Make sure that Q9 output: Increases to 6.5-7.5Vpp at 100Hz input signal.
Decreases to 3.5-4.5Vpp at 1kHz input signal.

6. TUNING INSTRUMENT

For the adjustments concerned with P/V and VCO circuits a precise tone generator is required - E note is preferable. Shown below is an example of E scale generator circuit configuration. It draws DC from SPV-355 +15V supply. Alternatively, an electronic organ or piano delivering the range of 32' E(F) to 2' E(F) can be used. In this case the organ/piano must be set to provide simple waveform sounds without frequency modulated like vibrato.

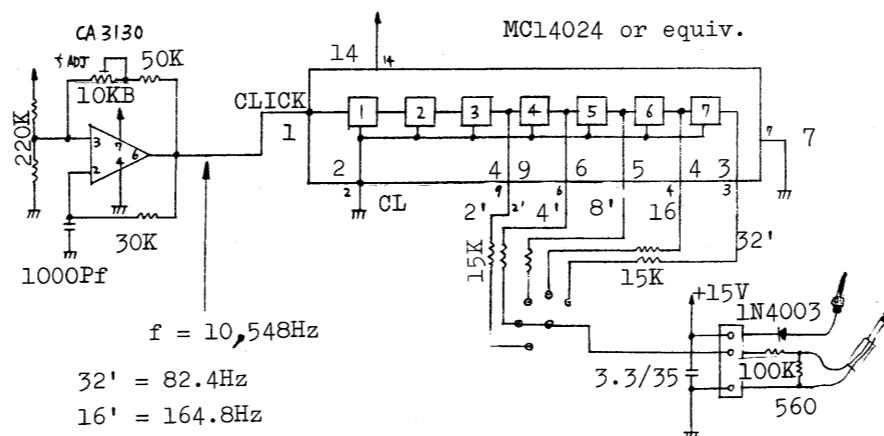

- f = 10,548Hz
- 32' = 82.4Hz
- 16' = 164.8Hz
- 8' = 329.6Hz
- 4' = 659.3Hz
- 2' = 1318.5Hz

TRUTH TABLE

INPUTS				OUTPUTS	
CL	PR	D	CP	Qn+1	Qn+1
L	H	*	*	H	L
H	L	*	*	L	H
H	H	*	*	L	H
L	L	L	↑	L	H
L	L	H	↑	H	L
L	L	*	↓	Qn	Qn

* : Don't care • : No change

7. PITCH to VOLTAGE CONVERTER (TIME to VOLTAGE)

Observe precautions:
plenty of warmup (15 minutes or more)
avoiding direct heating/cooling
taking steps in order of number

Connect: Digital Meter to CV OUTPUT jack.
Reference Note into INPUT jack.

Set INPUT Selector at GUITAR.
Keep input signals at a level just before Red LED goes on by turning THRESHOLD each time for different feet.

COARSE

- 1) Set the generator at 32'E or 32'F.
- 2) Set VR-9 for approx. 0.333V(E) or 0.417V(F). (call this Y)
- 3) Set generator at 16' and adjust VR-8 for 1V + Y.
Y will vary according to VR-8 turning; but leave it varying and keep VR-9 untouched. Only by turning VR-8 try to obtain 1 + Y, e.g. Y = 0.346, 1 + Y = 1.346V.
- 4) Set generator at 2' and adjust VR-7 for 4V + Y.

FINE

1) By turning VR-7 and VR-8 in turn at individual feet, obtain the voltages listed below with Y checked every time after VR-8 is turned.

VR-9 (FREQ)	32'	Y	The tolerance of 36' to 2'
VR-8 (WIDTH)	16'	1V+Y	should be less than 3mV for
VR-7 (LINE)	8'	2V+Y	practical applications.
	4'	3V+Y	
	2'	4V+Y	2) Set VR-9 for 0.333V at 32'.

MC14013B

DUAL TYPE D FLIP-FLOP

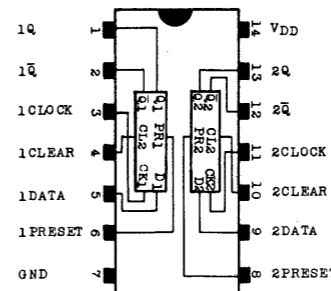

MC14066B CP

QUAD ANALOG SWITCH
QUAD MULTIPLEXER

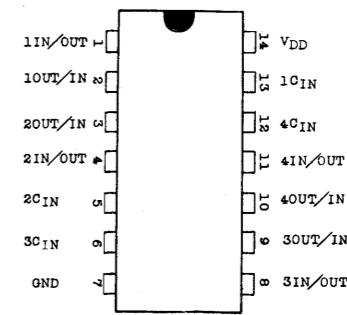

MC14011B

Quad 2-Input NAND Gate

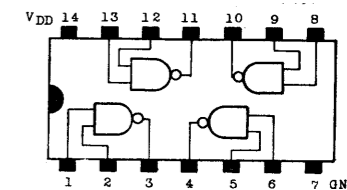

MC14001B

Quad 2-Input NOR Gate

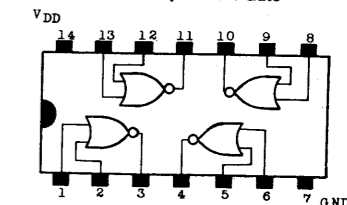

8. VCO

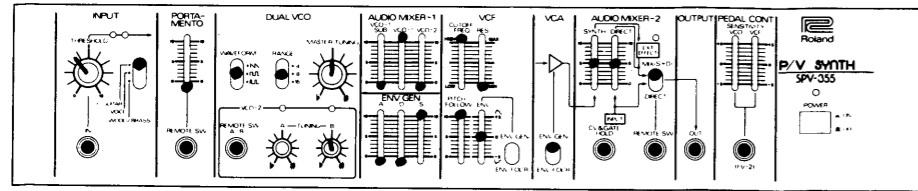

- VCO-1 -

Set panel as indicated above.

Connect: Scope and Amp + Speaker to OUTPUT jack.

Reference Generator into INPUT jack.

1. With the reference generator set at 4', adjust VR-12 for zero beat sound between Direct and Synth sounds.
2. Set the note at 8' and turn VR-11 for zero beat then advance it for few beats - amount of turning degrees after zero beat is proportional to deviation.
3. In the same manner produce few beats by turning VR-12 with the note set at 4'.
4. Repeat steps 2 and 3 for zero beat at 8' and 4'.
5. Apply the same procedure for the following combinations.

(1)	(2)
4' VR-12	4' VR-12
16' VR-11	32' VR-11

6. Check 32' to 2' for beat sounds. Adjust VR-13 to reduce them at 4' and 2'.
7. If the adjustment results in undesirable, re-adjust from step 1.
8. Finally, adjust VR-13 for the least beats at 4' and 8'.

- VCO-2 -

Set: VCO-1 knob in AUDIO MIXER-1 at 0.

VCO-2 knob at 10. TUNING B at its center.

The rest at the same as for VCO-1.

1. Follow the steps in VCO-1 section reading VRs:

VR-11 as VR-16, VR-12 as VR-17, VR-13 as VR-18.

9. VCF

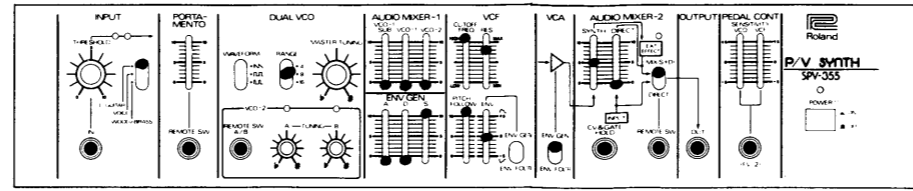

Set controls as shown above.

Feed a signal within the range of 200Hz-1kHz.

Set THRESHOLD just before INPUT Red LED goes on.

Connect oscilloscope into OUTPUT jack.

- RESONANCE -

1. Place RESONANCE knob at "8" grade.
2. Adjust VR-23 for VCF oscillation.
3. Slide RESONANCE down at "7.5", if oscillation does not cease, reverse VR-23 slightly.

- WIDTH -

1. Set RESONANCE at "10".
2. Set CUTOFF FREQ knob for 1kHz oscillation.
3. While quickly switching RANGE switch 8' to/from 4', adjust VR-31 so that 4' wave form becomes twice 8' cycle.

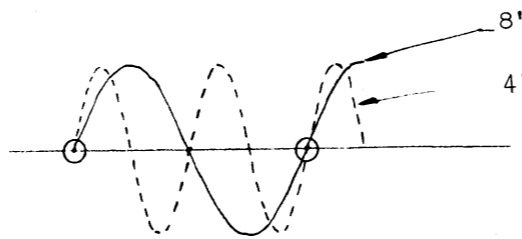

- FREQUENCY -

Set PITCH FOLLOWER knob at "0". CUTOFF FREQ knob at "HIGH".

1. Adjust VR-32 for 20kHz oscillation.(50µs per cycle)
2. Slide CUTOFF FREQ down at "LOW". The oscillation must be retained with its amplitude decreased.

10. VCA

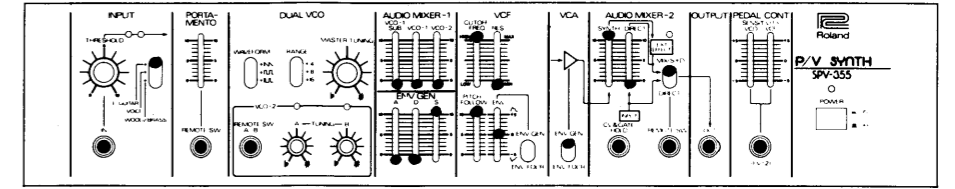

Set controls as illustrated above.

Connect Audio Generator to INPUT jack.

Connect Scope and an Amplifier with speaker to OUTPUT jack.

1. Set Scope and Amplifier for most sensitive conditions.
2. Set Generator at any one frequency from 100Hz to 200Hz.
3. Set Generator in BURST Mode. (substitution for Burst: application of intermittent ground on hot terminal on INPUT jack, or repetitive THRESHOLD rotation clockwise, counter-clockwise).
4. Adjust VR-27 for minimum click sound.

11. SYNTHESIZER OUTPUT RATING

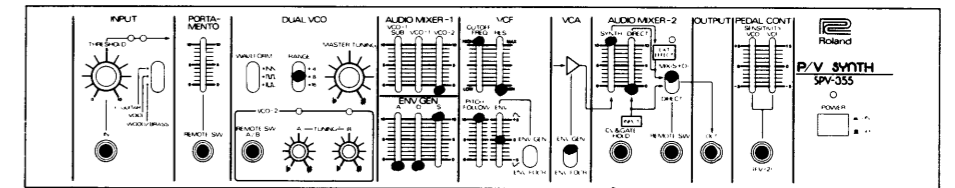

Typical levels with panel set as above (input 400Hz).

	INPUT SELECTOR			
	GUITAR-WOOD/BRASS		VOICE	
AUDIO MIXER-1	OUTPUT jack	EFFECT SEND jack	OUTPUT jack	EFFECT SEND jack
VCO -1, -2	-20dBv	-21.5dBv	-41dBv	-21.5dBv
	-18dBm	-19.5dBm	-39dBm	-19.5dBm
VCO -1, -2	-19dBv	-20dBv	-39.5dBv	-20dBv
	-17dBm	-18dBm	-37.5dBm	-18dBm
VCO -1, -2	-22dBv	-23.5dBv	-43dBv	-23.5dBv
	-20dBm	-21.5dBm	-41dBm	-21.5dBm
SUB	-20dBv	-21dBv	-41dBv	-21dBv
	-18dBm	-19dBm	-39dBm	-19dBm