

SWISS SOUND

VIEWS AND NEWS FROM SWITZERLAND

A PUBLICATION BY STUDER REVOX

No. 12
July 1985

Editorial

Why subsidiaries?



Do you still remember? Five years have already passed since the "Grand Opening" of the expanded STUDER REVOX AMERICA in Nashville, Tennessee (photo). Dr. Studer himself inaugurated the new offices at a press conference held on the occasion. For STUDER REVOX, the engagement in the United States turned out to be great success, and this is why we want to examine the reasons which lead to the decision to set up a subsidiary.

There are a variety of considerations which may stand behind the intention to establish a subsidiary in a particular country. In many cases, important aspects are undoubtedly the courage and the readiness to make an investment. This has to be combined with the determination to hold out over an extended and most likely difficult initial period so as to secure a certain market share – an effort for which an independent agent may lack the strength.

In certain cases such an undertaking may have been of necessity, because the increase in the range of available products could not be coped with by an appointed agent, neither financially nor staffwise. There may have been the lack of willingness on part of the agent to expand and to accept problems associated with such an expansion.

Furthermore, it has been our experience that only the complete integration, which is the case with our subsidiaries,

results in their genuine identification in the sense of being part of a large family. Out in the field, each member, may it be the service technician or someone in managerial position, truly reflects and represents the interests of the parent company, and the flow of information is ensured on all levels.

There is no doubt that the success of a subsidiary company largely depends on the qualification and identification of all those which are part of an operation. If, however, staff selection has not been optimal, large set-backs will have to be expected.

Our decision to pursue such a marketing policy has been a correct measure; this is reflected in the commercial success showing that more than one third of our total turnover – and this with increasing trend – is realized by our subsidiaries.

Beside this, however, we greatly rely on the support of our independent agents of long standing with whom a very close relationship is maintained and their genuine cooperation, reflected in the manner by which they represent our interests, so that many are regarded "insiders".

With the business year 1984/85 now being over, we would like to take this opportunity to express our sincere gratitude for the excellent cooperation you have extended. Please let us all keep up good effort so that our customers find their confidence justified which they place in STUDER REVOX products.

Eugen E. Spörri



Studer A725 for controlling the quality of compact discs

Confidence is appreciated...

The production of compact discs has turned out to be a highly delicate task which means that severe inspections are necessary. It therefore comes as no surprise that the development of a special version for quality control (QC) was initiated by one of the world's leading CD manufacturers; and this based on experiences with the CD players REVOX B225 and STUDER A725. The following report gives some information about this special version called the A725 QC.

The Studer A725 QC is based on the professional A725 CD player. Its design, connection facilities, and operation are absolutely identical; the QC version can, therefore, be used like a normal A725. The only visible difference is a 26-pin socket (QUALITY CONTROL OUTPUT) on the rear through which the signals for quality control and

various other applications are accessible.

A new decoder PCB has been developed for preparing and decoupling the signals for the A725 QC. The signals available at the QC output have been generalized as far as possible so that the user can build his own interpretation circuitry for controlling the quality of the

SWISS 12 SOUND

Read in this issue:

	page
● B203 Timer Controller	2
● Hits with Studer	4
● The DASH-Format	5
● DC Capstan Drive	5
● CAD/CAM	9
● Who is who	10



Rear panel

CDs. Since potential defects such as bubbles, contamination inclusions, irregularities in the metallization can manifest themselves differently in the production of CDs, depending on the process, a fast and reliable quality control strategy must be implemented by the user. This is why STUDER does not offer the corresponding interpretation circuitry.

The signals for quality control

Local defects on the compact disc such as metallizing faults cause level breakdowns in the RF (data) signal. As a consequence some of the data become unreadable. The QUALITY CONTROL output makes the RF signal as well as two level signals (10% and 75% of the nominal RF level) available.

The digitized RF (data) signal and the clock are also lead out. This makes it possible to detect violations of the T-min./T-max. conditions of the EFM code (which manifest themselves in the case of local defects). The error flags of the two electronic error correction stages C1 and C2 can also be read. Little effort is thus required, for example, to compute the block error rate (BLER) which is a measure of the general quality rating of a compact disc. The user also has the possibility to connect an additional signal to an unassigned pin of the QC output. If additional information on the surface roughness of the disc or tracking problems are required, the focus or the radial error signal could be lead out.

Subcode information

All subcode data of the compact disc (P-Q-R-S-T-U-V-W) are also available at the QC output. The graphics information of future CDs can thus be read out.

Digital data output

The audio data are output in such a way that the interface can be expanded to

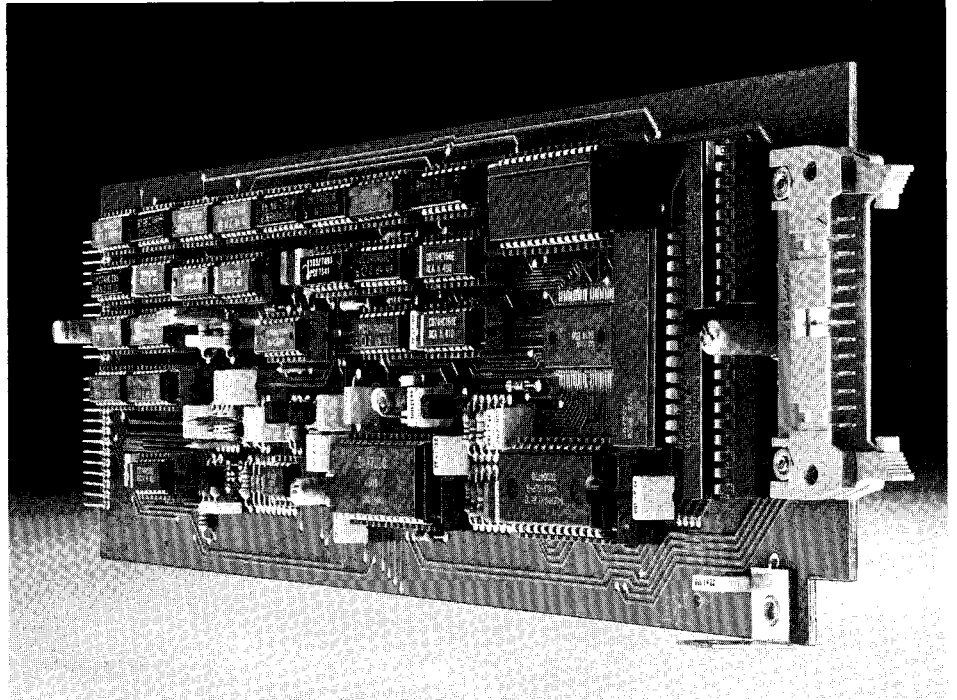

Decoder PCB

comprehensive data processing with relatively little effort. In addition the data are branched off before the digital over-

sampling filter so that also the data of a CD ROM can be read out.

David Roth



REVOX B203 Timer Controller Central control

With the remotability of all components within a hi-fi system, the prerequisite for additional concerted action is given. The "only" thing that is needed is a uniform interface and an intelligent system that can make the necessary decisions based on the software. The REVOX BIBUS is designed for implementing such a universal system control. The following introduction familiarizes the reader with the characteristic features of this system that will shortly become available.

The REVOX BIBUS interface has been prepared in all REVOX equipment ever since the appearance of the PR99 MKII in order to be able to offer a simple, uniform but still universal interface. This appears to be particularly important in a time where built-in microprocessors make it possible to

have highly similar features in the various hi-fi components, although the features are still rudimentary if this same equipment is to be used in an integrated configuration.

The link that is able to coordinate the communication between up to eight such interfaces of REVOX components is the REVOX B203 TIMER CONTROLLER.

Let us briefly examine its **characteristics:**

- The B203 supports timer functions such as we know from video recorders. These functions are programmable via infrared remote control (IR transmitter) or via personal computer (PC).
- The B203 also permits much simpler operation of the complete hi-fi chain in an interconnected system because

it is possible to transmit with the push of a single button an intelligent sequence of functions to the corresponding units. This principle, in the software referred to as EASY CONTROL, should support any type of tape recording from various sources.

- This "one-button operation" can also be initiated from a separate room by including a B206 as a remote receiver.
- An RS-232 interface is available for expanded applications. Control sequences can then be implemented by means of home or personal computers.

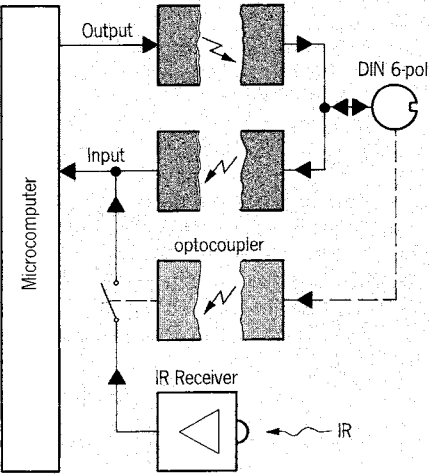

On the 6-pin DIN socket for the REVOXBIBUS there are electrically isolated lines available in addition to the 5V supply from the unit. They are used for feeding the electronics which in the activated condition automatically switch off the infrared receiver. The essential line operates as a bidirectional, serial equipment control link.

The REVOX BIBUS features two universal transmission formats that are suited not only for direct control without feedback, but also for feedback of received instructions or equipment states (status messages). An economic solution has been pursued. This is why the hi-fi components can be controlled directly with a serial code that is identical with the code in the integrated circuit of the hand-held transmitter B205. The complete instruction repertoire that is understood by the various units therefore contains at least all IR control commands of the B205.

For convenient control with feedback, the corresponding unit can be requested externally to report its status via the same active conductor of the control link. Such a complex communication method (e.g. status messages from the

equipment) can only be reasonably implemented with microprocessors. With this microprocessor in the controller it is possible to implement an **RS-232** interface with little additional effort. This interface has been laid out with respect to data format and speed in such a way that

it can operate with a vast range of home or personal computers. Internationally standardized ASCII strings with a transmission rate of 1200 baud are offered for this purpose.

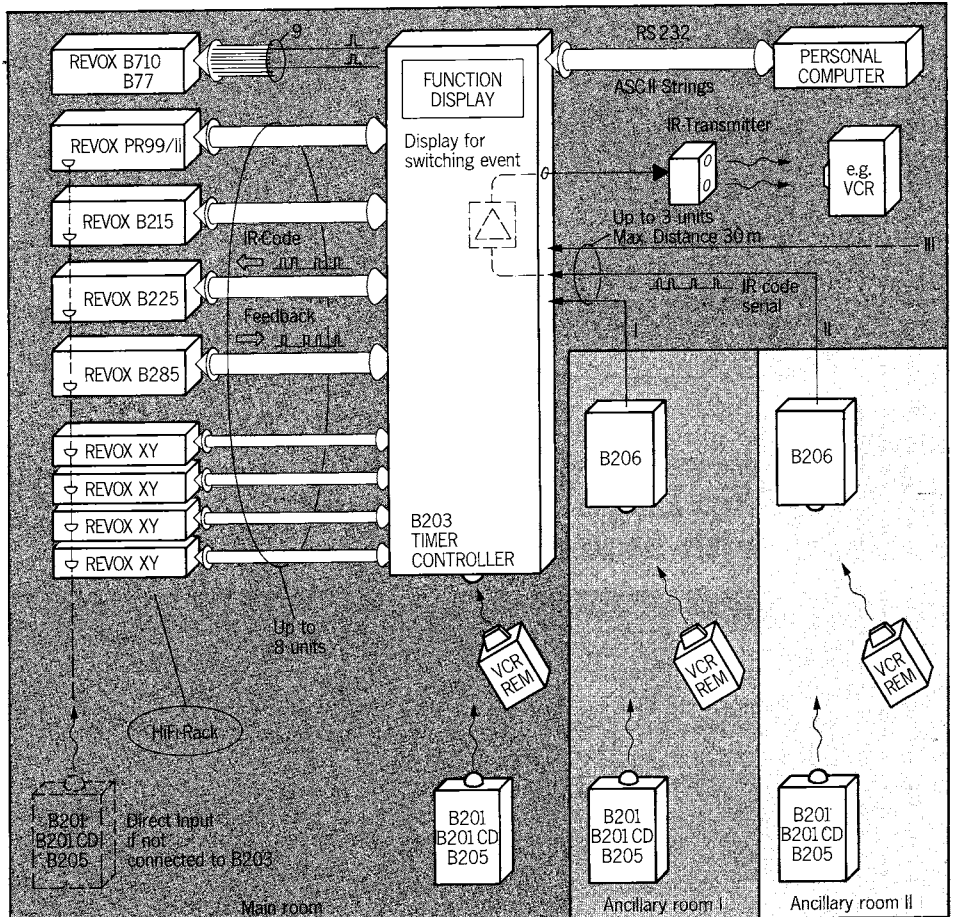

REVOX B203 timer controller, overall configuration.

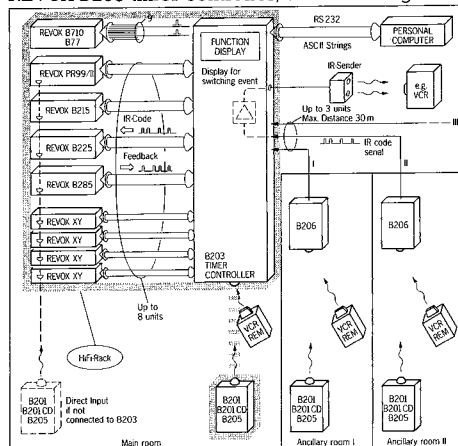

Basic connection configuration: "component stack" with B203 controller for a main living room. Up to 8 units can be connected serially. One unit with parallel command input can also be linked with the controller. The various units receive their specific IR commands no longer through their IR receiver but exclusively through the I/O socket.

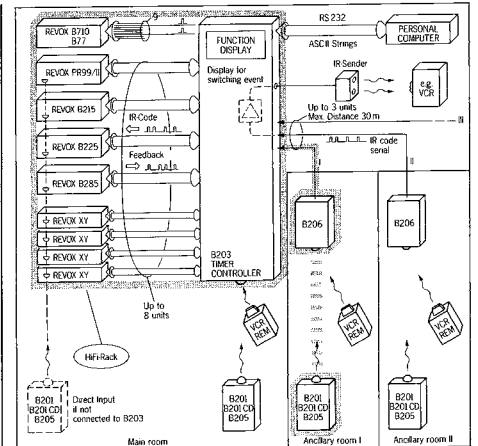

Expansion of the command input from two additional living or listening rooms is possible by plugging in B206 remote receivers. This simplified "EASY CONTROL" operating method allows software-assisted chaining of sequentially executed commands, initiated by a single push of a button.

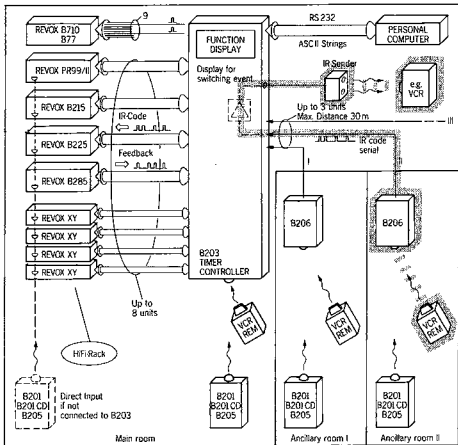

The flexibility of the overall system is enhanced by the fact that even an external IR signal (e. g. for video recorder) can be transmitted from an adjacent room to the B206 and be retransmitted by the B203 in the main room via the transmission adapter (repeater mode).

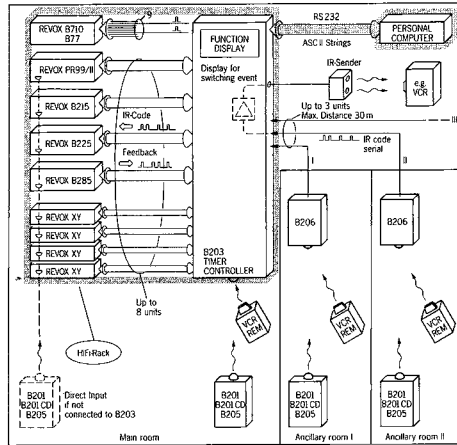

The built-in interface provides a link to additional communication media of today and the future. An obvious example: the personal computer.

Marino Ludwig



Successful Studer Machines
Top Engineer Mixes Hits with Studer

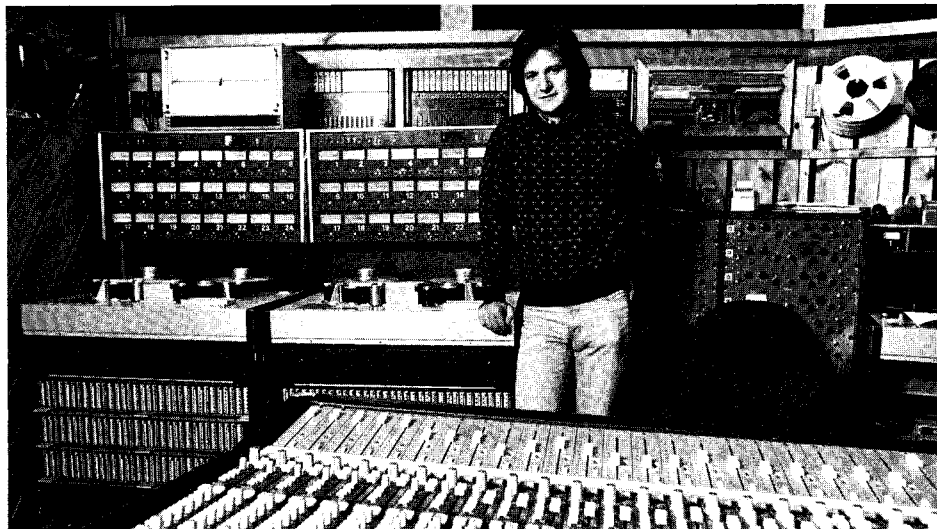

Bob Clearmountain in his favorite mixing room, Studio C at the Power Station, New York.

Question: What do the latest hit albums by Bruce Springsteen, Hall & Oates, Huey Lewis and the News, and Bryan Adams all have in common?

Answer: All were mixed by New York recording engineer **Bob Clearmountain**. This is quite an accomplishment for one engineer when you consider that all four LP's were in the top ten of the charts at the same time in late 1984. Combined sales of these four records now exceed 14 million units in the USA alone.

Bob Clearmountain is a perfectionist who insists on best equipment when producing his spacious, high-impact rock'n'roll mixes. It should come as no surprise, then, that all four of the above albums were recorded and mixed using Studer multi-track recorders exclusively. His preferred studio, the Power Station, now owns more A800 recorders than any other facility in the USA.

"I've always liked Studer recorders," says Clearmountain, "and the **A800** in particular. It seems to have a lot of 'bite' and it handles transients better than

most other machines. Also, it is very quiet. I used to be a die-hard Dolby fan back when the Power Station had the (other manufacturer's) machines because they were so noisy. When the Studers came along I just stopped using the Dolbys."

Clearmountain also praises the fast and accurate response of the A800 transport, particularly in the dual 24-track SMPTE lock mode which he uses extensively in his complex mixes.

Although primarily known as a mixing engineer, Clearmountain is now turning his talents toward production. He is credited as co-producer on the Bryan Adams (**Reckless**) and Hall & Oates (**Big Bam Boom**) albums. Other artists who have benefited from the "Clearmountain sound" include The Rolling Stones (**Tattoo You**), David Bowie (**Let's Dance**), Roxy Music, Little Steven, Chic, Ian Hunter, and The Clash.

Clearmountain's stunning success as a hitmaking mixer comes as result of patient perfectionism, technical expertise, and a gifted musical ear. With his talents, he could probably get by without Studer recorders. But, for now, he'd rather not try.

Bruce Borgerson

Good Sound Quality in great Demand

STUDER Equipment in German Theaters

The installation of audio equipment in a theater covers a wide and complex area. Perfect sound reinforcement, reliable balancing of sound effects or, an individual audio studio for production and dubbing is a typical example for accommodation of audio equipment in a theater.

It is not really surprising that STUDER IREVOX hold an important share in this area. There is hardly any German theater that is not equipped with STUDER REVOX products. In total, there are approx. 100 STUDER B 67, 200 PR 99, 40 A 80 RC, 30 A 810 professional tape recorders and about 20 A 80 multi-channel machines in operation, as well as some 70 STUDER mixing consoles 169/269 and an innumerable quantity of "smaller" equipment such as cassette recorders, tuners and amplifiers.

In this area of "dramatic performances", the new generation mixing console, **STUDER 900**, takes a very promis-

ing course which in view of the centralized position of audio control in a theater is not really surprising. The Hamburg Congress Centre operates three STUDER 902 mixing consoles, the Frankfurt Opera House will shortly receive a STUDER 904 and the «Old Opera» of Frankfurt City has just installed a STUDER 905 mixing console.



DASH

The DASH-Format for 2-Channel Digital Audio Recording

Digital audio recording allows many mutually incompatible formats. This fact, along with the short-sighted attitude of some companies, has slowed down the establishment of a world-wide standard for digital audio. Today, the trend is clearly in favour of DASH (Digital Audio, Stationary Heads), a format jointly supported and designed by Matsushita, Sony and Studer. At the Hamburg AES this Spring, Twin DASH, an extension of the Format further increasing its viability as a world standard, was presented. This provides an opportunity for a survey of DASH at Studer.

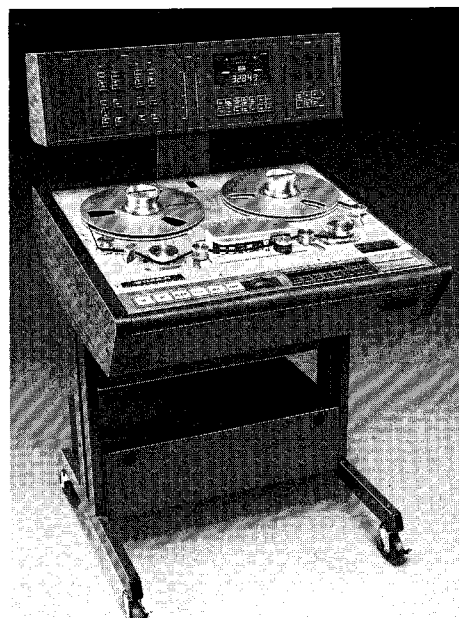

STUDER D820X, Digital 2-channel DASH Recorder.

What is DASH?

DASH (Digital Audio, Stationary Heads) is a set of technical specifications for ensuring the interchangeability of digitally recorded audio tapes. $\frac{1}{4}$ " tape is used for recording 2, 4 or 8 channels, while $\frac{1}{2}$ " tape is used for larger numbers of channels such as 24, 32 or 48.

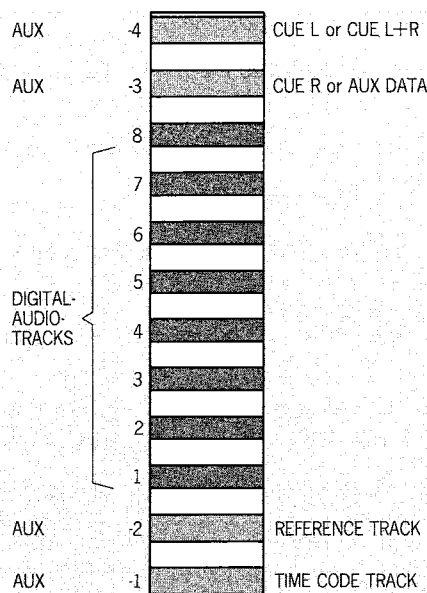

Track configuration for $\frac{1}{4}$ " tape (normal density).

As in analogue recording with a dedicated Time Code track, digital audio recorders require auxiliary tracks. In the case of a 2-DASH recorder, for example, 8 tracks are used for recording 2 channels of digital audio, and 4 additional auxiliary tracks for recording Cue signals, Time Code, Reference signals and auxiliary data. Obviously, recording 12 tracks on a $\frac{1}{4}$ " tape requires a very precise and gentle tape transport.

DASH and Studer

Our company has taken the decision of manufacturing its professional digital recorders according to the DASH format. In-between, the three companies which have originated DASH (Matsushita, Sony and Studer) have also decided to propose DASH as an international standard. Compared with the initial proposal by Sony, today's DASH format has had to undergo several stages of improvement and extension to render it viable both for practical use and for standardization. Studer's contributions in continually adapting DASH to the requirements of the professional world (a critical activity when recorders have to be developed at the same time) have been major ones.

DASH and Standardization

The path to world-wide standardization has always been arduous; surely, DASH will be no exception. The prospects for its acceptance are excellent, yet much remains to be done in order to make DASH fit harmoniously into the framework of existing standards of AES, EBU and SMPTE. In addition, the best support of a proposal for a recording format is obtained when recorders implementing it are providing their viability in practice. This makes it imperative for our company to begin production of the 2-channel recorders in the very near future, a challenge which can only be met through common and constructive efforts at all levels of our company.

At present, we are concentrating on a 2-channel DASH recorder at 15 ips, with a double recording strategy (called Twin Recording in the DASH format) which ensures the high level of reliability required in practical operations. More details will be made available in a next issue of Swiss Sound.

Roger Lagadec

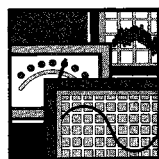

DC Capstan drive for STUDER A820 and D820

The "MicroCapstan" of the future

The development of tape drive mechanism runs parallel to the technical evolution and enhancement of magnetic recording in general. The first capstan drive was a synchronous motor locked to a reference. The successor was a tacho-controlled asynchronous motor with own reference. This type of drive which was

used for the first time in the REVOX A77 has been refined to a high degree of technical perfection over many years, also for professional applications. To satisfy the extremely demanding requirements of the future both for analog and the digital audio, a completely new drive system has been developed.

The combination of microprocessor and brushless DC motor is used as a capstan drive for the first time in the new STUDER A820.

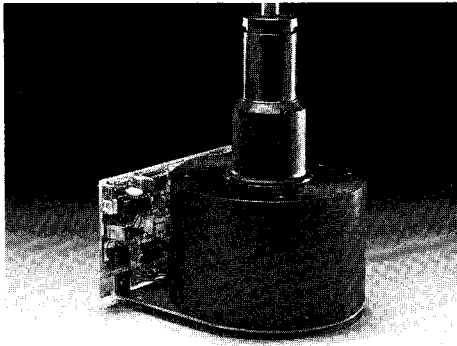

This system is the subject of two related reports from the hardware and software area. The first part called "Micro Capstan" describes the drive consisting of motor, tachometer, power controller, and 3-phase inverter. The second part, "Micro Capstan", deals with higher ranking speed control by means of a microprocessor.

Part I Micro Capstan

Capstan drive system

The basic elements of a capstan drive are illustrated in Fig. 1. These comprise the following functional assemblies:

- Speed controller (microprocessor; described in Part II)
- Power amplifier (power regulator and inverter)
- Motor
- Speed sensor (tacho)

New DC capstan motor

In the STUDER A820 the capstan motor starts with the pinch roller assembly engaged and is ramped up to the desired speed as soon as the play or the record function is initiated.

A motor had to be found that meets the following characteristics:

- Fast acceleration (0 to 76.2 cm/s in approx. 0.1 s)
- Optimum controllability
- High efficiency
- Smooth running (minimal torque pulsations)
- No stray fields
- Low inertia

The above requirements can only be satisfied within reason by using a DC motor.

The excellent controllability is the outstanding feature of the DC motor. As is well known, a DC motor can be transformed from a driving into a braking device by continuously decreasing the input voltage. In the braking phase it acts as a generator and feeds back the elec-

trical power originating from the conversion of mechanical rotation energy (= braking). The equivalent circuit diagram (conventional DC motor) is illustrated in Fig. 2.

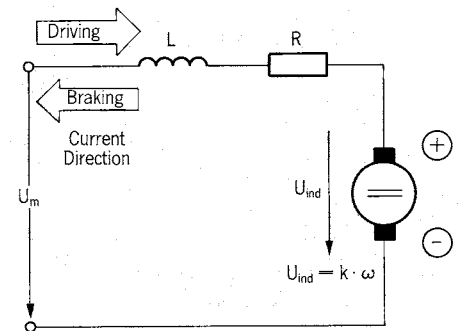

Fig. 2: Equivalent circuit for the DC-Motor.

The return feed is based on reversing the current direction as soon as the internal voltage source (U_{ind}) becomes higher than the external voltage U_m .

For professional applications and when taking the STUDER concepts into consideration, the following parameters have to be considered:

- Long service life (no parts subject to wear)
- Operation under all ambient conditions (-25 to $+55^\circ\text{C}$)
- Silent operation
- No brush sparking (= interference)
- Stable mechanical friction (= no brush friction)

Since no existing motor was able to satisfy all of these requirements, a completely new motor had to be developed. Together with the selected control principle, this new STUDER DC capstan motor opens entirely new dimensions with respect to controllability, synchronization, and remotability.

Motor specifications:

Type:
3-phase, brushless DC motor with laminated stator.

Zero-speed torque: 3.8 kgcm (0.37 Nm)
($U_{INV} = 40\text{V}$)
(for comparison: zero-speed torque of A810 spooling motor: 3.65 kgcm)

Acceleration from 0 to 76.2 cm/s:
(tb) less than 85 ms

Inverter

In contrast to a conventional DC motor, the brushless motor requires considerably more electronic circuits. Fig. 3 illustrates the layout of the inverter output stage.

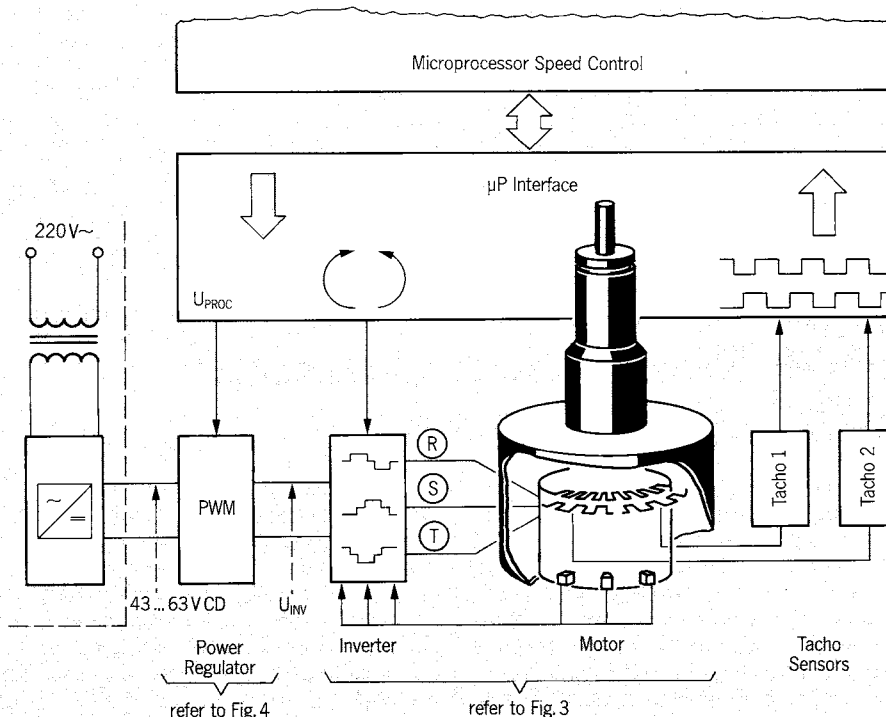

Fig. 1: Capstan motor with microprocessor for speed control.

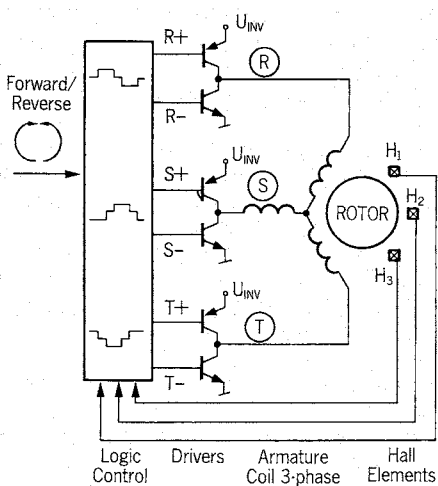

Fig. 3: Inverter Stage.

The inverter output stage comprises:

- Hall elements
These continuously report the current position of the rotor.
- Logical control
Decides which switches (transistors) are to be opened or closed. The sense of rotation can be selected by setting a bit.
- Switches (transistors)
These transistors conduct the current through the winding across the right path.

An inverter output stage and a brushless DC motor together constitute a "normal" DC motor and also have the same control characteristic.

Voltage controller
(power controller - DC/DC converter)
The response to setpoint changes of the motor depends directly on the "hard" voltage source. Since the driving and braking torque is proportional to the cur-

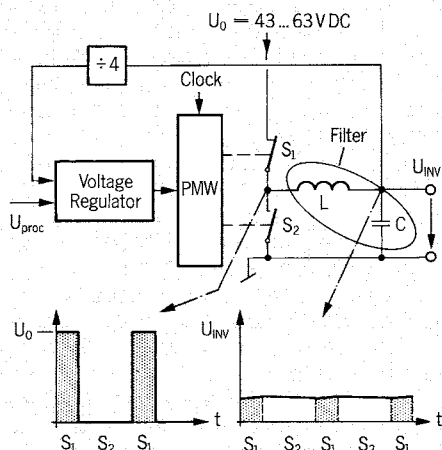

Fig. 4: PWM-Voltage regulator (power regulator).

rent flow, it is desirable to couple the motor with low impedance to the external voltage source. The voltage regulation has the effect that the required voltage U_{inv} is available on the inverter without being influenced by uncontrolled impedance losses (Fig. 4).

Two alternately activated power MOSFETs S1 and S2 are driven by a pulse-width modulator in such a way that always the quadruple of the analog voltage U_{proc} applied by the processor is available on the subsequent inverter. This results in a cool running capstan power stage of high efficiency and higher reliability due to its low operating temperature. The switches are clocked with 76 kHz, in synchronism with all switched power assemblies of the machines. Should a clock failure occur, the capstan power controller operates autonomously by preparing its own frequency. The processor would be unable to operate without this subsidiary voltage control because it depends on the fact that a gain factor of 4 is maintained regardless of the AC supply voltage and the load on the motor. This gain factor of 4 is no longer ensured under the following circumstances:

- Drop in the AC supply voltage by more than 20%.

- Blocking of the capstan motor during more than 5 seconds, because the protective circuit responds after this time.
- Inadmissibly low 5V logic supply (short-circuit protection of the inverter transistors).

Speed sensing (tacho)

Two tacho rings supply information concerning the speed and the sense of rotation in the form of variable capacitance. This information is transmitted to the processor via two lines, thus closing the control loop of the capstan system.

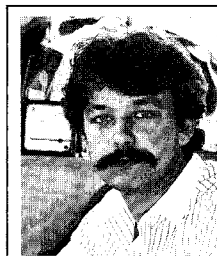

Christoph Studer (28):
Graduated 1981 at Zurich ETH (Federal Institute of Technology) in electrical engineering. Specific studies in control circuitry and power electronics. After practice in the control of high current welding equipment, joined WILLI STUDER

AG in late 1982. Various assignments in the central laboratory with emphasis on motor control and motor control circuitry, e.g. capstan control of the STUDER A810; capstan motor and control electronics of the new STUDER A820; PCM power supply of the STUDER D820.

Christoph Studer

Part II Micro Capstan

About the necessity of a microcomputer-based solution

At the start of the development many new requirements were specified for the capstan motor. Some of the most important ones were:

- Good dynamic behavior, and defined as well as variable dynamic characteristics (defined transitions between two speeds)
- Accurate control behavior
- Positioning capabilities
- Reverse operation
- Possibility of assuming tape counter functions
- Flexibility for modifying the motor characteristic or for introducing new features

Some of these requirements could be implemented with hardware alone, but in a complex environment involving a large number of functions for which the corresponding effort would no longer be economically justifiable. This is why the decision was made in favor of a microprocessor-oriented solution. Based

on previous experience gained from the series MC6801/03, the powerful MC6803 processor was chosen.

The software and the digital hardware were developed in parallel. It was therefore possible to optimally distribute the functions between the hardware and the software.

Hardware section of the microprocessor control

The block diagram (Fig.5) illustrates the hardware solution of the capstan speed controller. The capstan motor supplies the controller with two tacho signals, the phase of which is offset by 90°. From these the controller decodes the double tacho frequency and the actual sense of rotation. This new tacho frequency is taken to the MC6803 via a microprocessor-programmable divider (to ensure that the measuring accuracy remains independent of the tape speed). The MC6803 measures the period of the tacho signal. Normally the controller receives the speed reference from the tape deck processor, via a parallel interface, together with other commands.

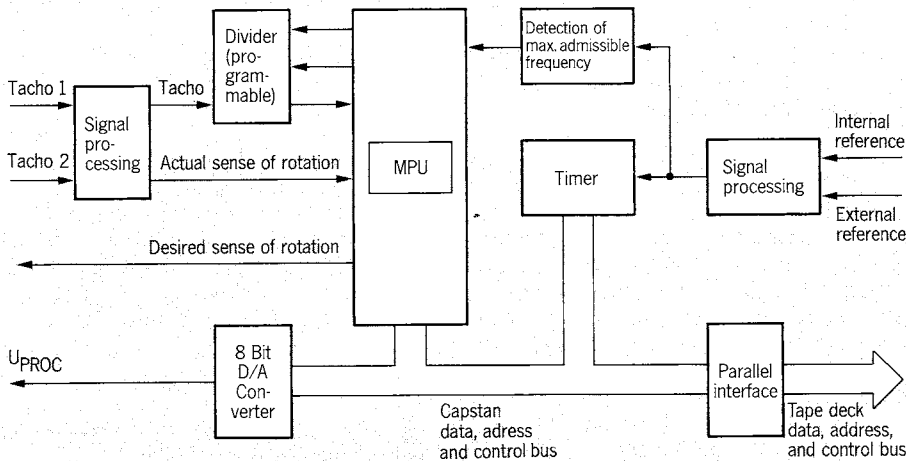

Fig. 5: Block diagram of the capstan speed controller.

The system is also able to define the desired capstan speed by means of an external or an internal reference frequency. The prepared frequency is measured with a timer (MC6840). To ensure that the processor will not be permanently busy when an incorrect or an excessively high reference frequency is fed in, a hardware detector for the maximum frequency has been added. In such situations the measurement is inhibited by the detector.

The control loop to the power amplifier is closed by outputting the desired sense of rotation and the control voltage U_{PROC} from the 8-bit D/A converter.

Software section of the microprocessor control

The software comprises the following parts:

- Special real-time control routine controlled by time interrupts
- Interrupt routines for measuring the actual speed (period measurement of the tacho signal) and the reference speed (period measurement of the reference frequency)
- Communication routine for the link with the tape deck processor
- Monitor programs for man/machine communication via terminal
- Control routine that supervises the program execution

Fig. 6 contains a flow chart of the control routine that represents the crucial point of the software. This routine is reinitiated every 2.1ms by the interrupt control block. This block protects the processor so that the latter can function properly also in the event of overloads.

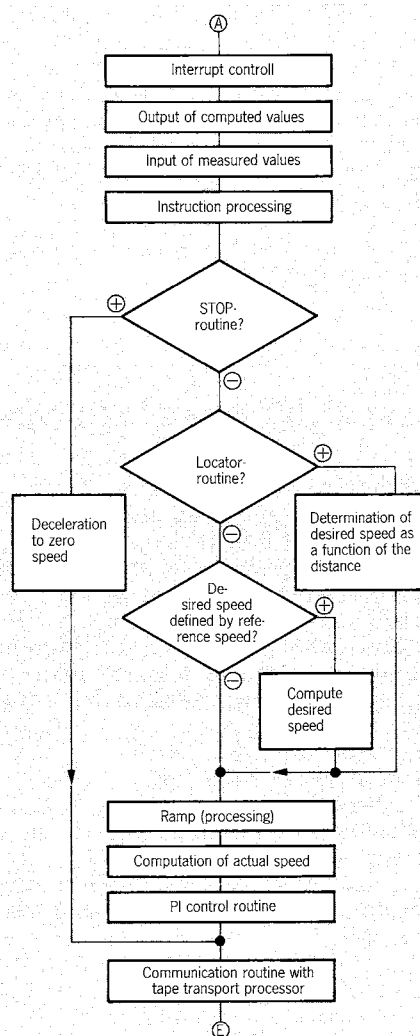

Fig. 6: Flow chart of the control routine.

The capstan motor receives the following commands from the tape transport:

- Stop
- All PLAY functions (including reverse PLAY)
- Status inquiry (after this command the capstan processor reports the current status to the tape deck processor)
- Tape dump (waste basket mode)
- CUT (positioning in front of the scissors)
- Locate Play (positioning at a specific tape address)

Additional commands set the following parameters:

- Set Play Speed (sets the nominal tape speed)
- Trim Nominal Speed (for fine adjustment, determines the nominal speed in steps of 0.25 per mill within the range of ± 2 per mill)
- Set acceleration (defines the slope of the speed ramp, which is depending on the reel size and the hub diameters. Having the tape deck processor determine these variables ensures that an optimum starting ramp is attained that makes maximum use of the acceleration capabilities of the tape transport mechanism)
- Set Varispeed (for adjusting the reference speed in varispeed playback)

Depending on the received command the capstan system selects the appropriate operating mode, i.e. the routine in which it operates. Because the tape deck processor transmits a status request command in regular intervals, the capstan processor can check that this communication takes place regularly. In the event of a communication failure the capstan control enters STOP mode.

Except for the stop command, all routines use a PI speed control routine after the reference speed has been determined. For attaining optimum control behavior the control constants are defined as a function of the speed or the ramp. A time-consuming part of the routine is the computation of the actual speed from the period of the tacho signal (precision of the division better than 12 bits). At the end the communication routine is called which is responsible for receiving the commands from the tape deck processor. The transmit routine runs in the background, its execution is supervised by the control routine which supports multiprocessing with the monitor programs. The communication capstan/tape deck is executed with a protocol that has been specifically developed for this purpose and which checks the communication.

Results

The capstan drive with microprocessor control delivers the expected characteristics and satisfies all specifications.

It is able to achieve better wow-and-flutter ratings than its predecessor and this with a tape speed accuracy of better than ± 0.25 per mill. But its main advantage are the dynamic characteristics. All changes to the reference speed are achieved with a defined ramp which ensures very gentle tape handling. Since this ramp is definable, the recorder can take full advantage of the dynamic characteristics of the tape transport. Also the transient response is under full control of the processor. The dynamic characteristics are illustrated in Fig. 7. These excellent parameters are achieved in both rotation directions.

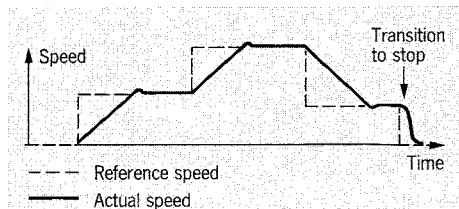

Fig. 7: Dynamic characteristics of the capstan drive.

The ability to make simple changes to the control constants is the reason why a speed control range from $3\frac{3}{4}$ to 30 ips with a deviation of ± 7.5 semitones is possible. Independently of this range the tape speed can be fine-adjusted within ± 2 per mills.

This high-resolution tacho system is also ideal for accurate tape positioning. In the CUT function, for example, the capstan moves the tape from the reproduce head to the scissors with an accuracy of better than ± 1 mm.

But the main benefits are the flexibility in changing the specifications as well as in customizing the machine to the requirements of the users and in creating new functions, a concept that has already proven itself during the development phase.

Karel Hlavica



Dr. Karel Hlavica (32)

Studies at Prague University, 1976 diploma of electro engineering. Promoted 1981, doctor's degree on the subject of Speech Recognition. Practical work in development and application of robot systems. Joined

WILLI STUDER AG in late 1981; laboratory work on A 820 transport, Capstan control system and serial interface for communication of processors.

For outsiders, complex circuit boards densely packed with components and uncountable interconnections are the true embodiment of mysterious and puzzling electronics. The aim of the professional, however, is simply to "artfully" translate the circuit layout into an optimal printed circuit.

The following report is intended to give a first glimpse at these creative and productive tasks performed with the assistance of a computer.

For quite some time, electronics or more precisely the computer technology, has ceased to be the exclusive domain of administrative data processing; for programmable control of production processes it has long proven itself, and the computer technology is on the verge of becoming an important tool for creative processes.

CA.. - an abbreviation with implications

CA stands for Computer-Aided, i. e. assisted by the computer. An additional letter specifies the objective: **D** for Design, **M** for Manufacturing, and **A** for Automation. **CAD** and **CAM** are abbreviations that are of interest in conjunction with the development and production of printed circuits. This again is only an example, albeit a particularly vivid one, for a development that will enjoy widespread use in the near to medium-term future (in progressively minded companies!).

Complex problem definition

Printed circuits are normally created from a circuit diagram whose final form is based on a laboratory model. Not only the individual point-to-point connections are important but there are at least some notions concerning the arrangement of the components, the required ground surfaces (screening), supply lines, etc. The grid dimension, conductor spacing, conductor widths, soldering eyelet dimensions, soldering stop pressure and mounting pressure, are only some of the many factors that have to be taken into consideration during the design phase. In densely packed circuits, particularly in digital technology, two levels (soldering side and components side) are frequently no longer adequate which means that multilayer circuits have to be implemented.

The growing design complexity is accompanied by greater sophistication in the corresponding manufacturing steps. It is essential that the designer is not only aware of this factor but he must

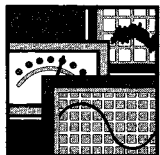

CAD/CAM for designing and manufacturing printed circuit boards

Art on the screen

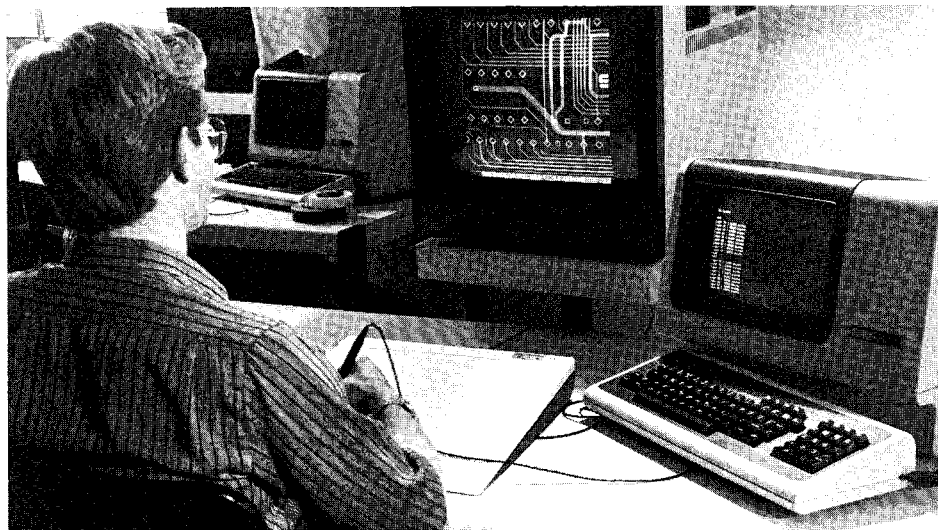

CAD workstation with colour monitor and terminal.

also master it. The consequence: in view of these requirements it is understandable that circuit board design specialists should be relieved of routine functions. This is precisely what a correspondingly programmed computer does.

CAD - the intelligent aid for a creative development phase

The CAD system for developing printed circuits comprises the following basic units:

- Main processor with alphanumeric terminal and large memory capacity. Ports for connecting up to 8 workstations via fibre-optic cables as well as 4

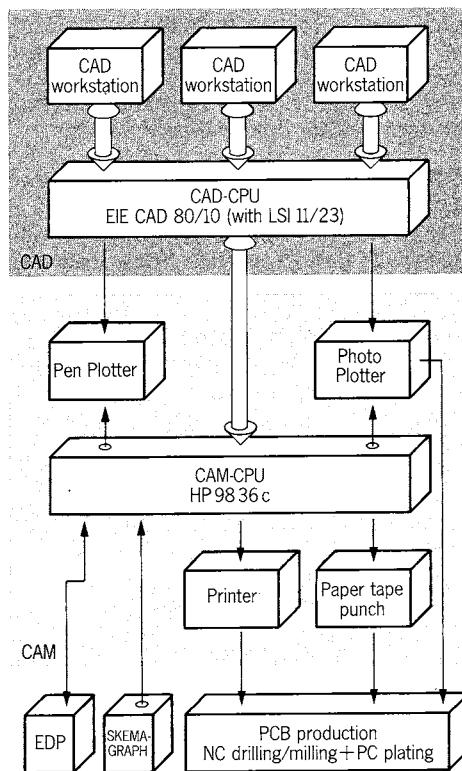

Principal system for printed circuits.

interfaces (RS-232C for peripheral devices).

- 3 Workstations with graphics terminals and each with a separate working computer together with graph tablet and monochrome monitor, as well as devices controllable from the CAM area:

- Photo plotter for single PCBs (prototypes)
- Pen plotter for checking purposes

For designing the circuit the operator uses a high-resolution color screen (64 colors), a keyboard, and a graph table

with pen. On the software side the computer has access to various libraries containing the components and their circuit diagram symbols and for the geometric dimensions. New components can be added to this library at any time or existing entries can be modified.

The actual work starts with the input of the circuit diagram (drawing on the table with the aid of the electronic pen). From this the computer prepares automatically a wiring list and a parts list.

The circuit design can also start with outlining the contours and subsequent positioning of the components. Since the computer knows each component by its pin numbering, it is able to automatically establish the desired connections. In practical applications the computer is allowed to establish only some of the connections so that manual intervention is possible. In addition some of the connections such as the feeder lines can be predefined in interactive mode. Shifting and rotating of components is possible in every phase and the connections that are still open are indicated on the screen by blue direct connections across the circuit board.

In addition to the generous facilities for creative design, computer assistance also involves various test routines.

For instance the parts and wiring lists can be checked for duplicate or still open connections or for unassigned pins. In the finished circuit design the conductor spacing can be checked as well as the angles. In the event of ambiguities the color screen offers extensive zoom facilities for looking at the exact details and for dimensioning. For example, trap holes can be accurately positioned and measured with the system. In addition it is possible in all phases of the work to prepare multi-colored paper drawings with the aid of the pen plotter.

CAM - the logical step toward efficient production

The CAD system now "knows" everything about the future PCB. To analyze and channel this large volume of data is the responsibility of postprocessing by means of an in-house configured computer system with color graphics screen. The following basic units are also part of the CAM area:

- Photo plotter for exposing the multiple films
- Pen plotter for printing the verification drawings
- Devices for punching paper tapes

that are to be processed on NC drilling and milling stations.

This system is an important production interface. The computer system is also used for preparing the documentation for assembly drawings, printing masters for solder stop masks, for automatic inserters, in-circuit test programs, PCB costing, etc.

The introduction of CAD/CAM for designing and manufacturing printed circuits is far more than a fascinating game on modern color monitors - it is another significant step for maintaining our production edge on a wide basis.

Marcel Siegenthaler

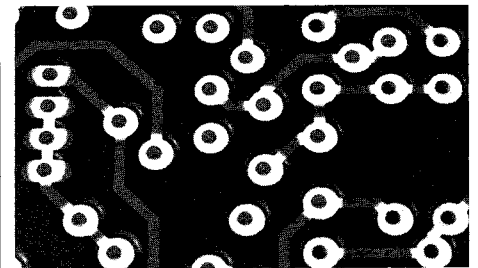

The Studer Group
of Companies

«Who is who»

This column has been reserved for introduction of personalities of our affiliated companies and representatives in Europe and Overseas.

Introducing:

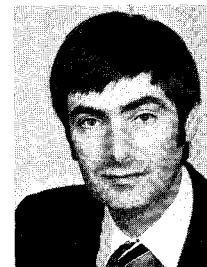

Peter Joss

Head of the Technical Department of Studer International AG ● born 1944 at Konolfingen, Canton of Berne ● school education at Zurich ● graduated in Electronic Engineering and received his BSC ● additional courses at Zurich School of Economics ● various courses of technical and commercial nature ● member of AES, SMPTE, JCC ● married, two daughters ● with STUDER since 1968.

When Peter Joss joined the test department for studio machines at WILLI

STUDER seventeen years ago, he had finished his apprenticeship as an electro-mechanical technician and draftsman for control devices. Between 1969 and 1971, he worked at the laboratory for the development of the professional magnetic tape recorder models STUDER B 62 and STUDER A 80. The evenings were dedicated to studies in various professional areas.

To improve his English, and also to establish contact with the world of the STUDER customer, Peter Joss left the "place of origin" to change from development to practical work at the service department of the STUDER representative for the U. K. - F. W. O. Bauch Limited in London. The change was positive; Peter Joss not only had the chance to gain valuable experience in all matters of after-sales-service, but also acquired the skill to deal with and solve technical problems. He also visited studios, met studio people and celebrities like the Beatles, the Rolling Stones, Rod Stewart, Cat Stevens and others of that time period.

Back in Switzerland, Peter Joss was appointed technical sales engineer in 1972 at Studer International AG and looked after the markets of England, France, Benelux and the Far East. His sales initiative was complemented by his technical skill and served distributors and endusers alike. The growing requirements of new technologies asked for more activities in all markets.

In 1976, Peter Joss reorganized the small-sized technical department for the support of the sales organisation. He was also an active link between laboratory, quality control of the manufacturer and the requirements of the international sales organisation. A close cooperation developed with the manufacturer. In spite of the growing professional product range, the maintenance of older type machines (such as the legendary STUDER C 37) was not to be neglected either.

Demands on the technical side grew with the requirements; more staff was hired. Today, 20 technicians/engineers form an efficient team: Product Engineers, specialized in the technology of magnetic tape recorders, mixing consoles, synchronisation and PCM-systems who also work as sales promoters; special projects engineer, a crew of technicians and engineers who carry out installation work with great expertise. There are maintenance and repair services, and a mechanic department.

For these groups, activities are planned and organised, training courses for technicians and operators of our distributors and customers are carried out, technical seminars held and product information passed on. Well considered concepts form the basis of training courses which year after year are held in Regensdorf and enjoy frequent attendance. A good relationship with employees of our foreign distributors is of great importance to Peter Joss; it is emphasized by his visits to the various markets. He has looked after the entire Scandinavian market area from 1982 to 1984 in technical and promotional matters.

In the seventies, Studer International AG started to participate in international tender business with a complete product range and got into a further business sector: turnkey projects of broadcasting companies and recording studios to be equipped with STUDER tape recording machines or mixing consoles, with every bit and piece for studio accommodation supplied by Studer International AG.

Peter Joss has participated in the realisation of such highly technical projects to greatest extent. On his travels to the Near and Far East in connection with such projects, technical advice is most essential. He was also responsible for the technical part of a contract covering the know-how transfer to an Indian company which henceforth produced STUDER B 67 tape recorders locally.

He shares his leisure time with his family and has a number of hobbies; two daughters (9 and 10 years old) and two oldtimers (1947 and 1960, type MG) one as beautiful as the other, take some of his spare time. There is alpine and cross-country skiing and, lately, cooking under professional supervision.

The area of his interest is extensive. In connection with his duties within the company structure, he prefers efficiency and competence to do his job. Peter Joss: "Only a few years ago, there were certain limits to the realisation of a product concept. Today, new technologies pull down barriers and give way ahead. In consequence, better facilities for development, more flexibility in production and marketing result. Those who work with great skill, with dedication and pleasure will appreciate Heraklit's saying according to which "everything flows, only the change is constant".

Renate Ziemann

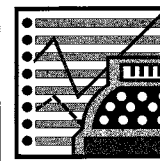

Right on success

Studer worldwide

Canada

CKNW Radio Station

After careful evaluation, CKNW radio of New Westminster, British Columbia, decided to buy the REVOX PR 99 MK II tape recorder. Day after day, 25 machines are operated in talk-show studios and the large news transmission room.



England

British Broadcasting Corporation (BBC)

Another 150 STUDER Tape Recording Machines of the B 67 type were supplied to the BBC. A lot of 70 machines are of B 67-0.75 standard type and 80 are BBC-specified compact equipment. An order for 63 STUDER A 80 RC-0.75 broadcast machines was also placed by the BBC. This special equipment will have its debut at the forthcoming Commonwealth Games.

Norway

Norsk Rikskringkasting (NRK)

NRK received the first supply of 9 STUDER A 810 professional recording machines in addition to 20 STUDER B 67 and one STUDER A 80 RC. This proves that STUDER A 810 has found acceptance at yet another large broadcast organisation.



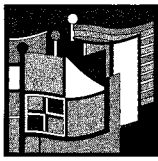

TV Symposium in Montreux

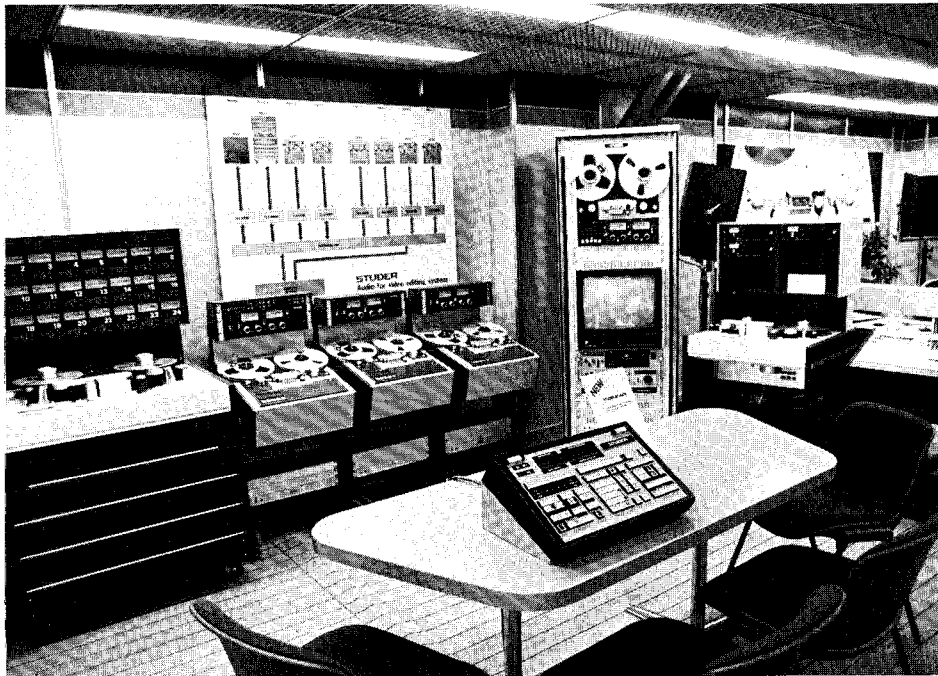

Audio becomes more important! There was hectic coming and going at the booth of Studer International AG. New products like STUDER A820, A810 TC/Pilot, the 961/962 mixing console and-

very important - the new synchronisation-audio-editing system TLS 4000/SC 4008 have drawn permanent attention at the Studer stand.

In brief...

STUDER A820

The serial production of STUDER A820 is in full swing. It appears that the A820 will be a hot tip among professional tape recorders. Recording studios prefer the A820 1/4" or 1/2" stereo master machine. Broadcasting companies are anxious to receive their first consignment of A820; the A820 TC version offers new possibilities for synchronizing applications.

Service courses

An additional training course held in German language, has been added to the course schedule at STI:
1985 December 2 - 5
STUDER A820, Tape Recorder

Outside Broadcasting Van

In April 1985, an OB-Van was handed over to British Forces Broadcasting Service in Cologne. The control room accommodates 2 mixing consoles STUDER 269 and 3 magnetic tape recorders STUDER B67 as well as a Cassette Deck STUDER A710 and Tuner STUDER A726.

For further information please contact

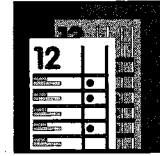

Forthcoming events

1985 August 28 - September 2
FERA, Zurich

1985 August 30 - September 8
Internationale Funkausstellung, Berlin

1985 September 30 - October 4
IREE, Sydney

1985 September 30 - October 6
SONIMAG, Barcelona

1985 October 10 - 13
12th Nordic Sound Symposium, Bolkesjo

1985 October 13 - 17
79th AES Convention, New York

1985 November 20 - 22
INTERBEE, Tokyo

1985 December 17 - 19
CTEAP, Paris

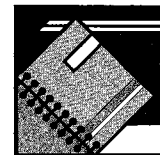

From the printers

- 10.26.0192 **D820X**, Flyer (e)
- 10.26.0290 **A810**, Accessory Flyer (g/e/f)
- 10.26.0320 **A725**, Brochure (g)
- 10.26.0330 **A725**, Brochure (e)
- 10.26.0350 **A820**, Brochure (chin.)
- 10.29.0240 **B215**, Brochure (span.)
- 10.29.0550 **B285**, Brochure (span.)
- 10.29.0660 **Agora B**, Brochure (g/e/f)
- 10.29.0192 **Piccolo-Bass**, Brochure (g/e/f)
- 10.30.0221 **B215**, OI (g/e/f)
- 10.30.0082 **B225**, OI (g/e/f)
- 10.30.0380 **B286**, OI (g/e/f)
- 10.18.1962 **PR99 MKI + MKII**, SI (g/e/f)

PI = Product information
TI = Technical information
OI = Operating instructions
SI = Service instructions
SD = Set of diagrams

Sets of diagrams, operating and service instructions available at nominal charge.

Please mail your letters to:

SWISS SOUND, STUDER INTERNATIONAL AG
Althardstrasse 10, CH-8105 Regensdorf
Phone 01/840 29 60 · Telex 58489 stui ch
Telefax 01/840 47 37 (CCITT 3/2)

Editors:

Heinz Schiess, Marcel Siegenthaler

Art and production: Lorenz Schneider

Publisher: WILLI STUDER AG,

Althardstrasse 30, CH-8105 Regensdorf

Reprint permitted with reference to

SWISS SOUND (please send a copy to the editor)

Printed in Switzerland by WILLI STUDER AG

10.23.8210 (Ed. 0785)