

TRACE ELLIOT

SERVICE MANUAL NO. SM00026

ISSUE 1

Date: April 9th 1998
Product Code : T3460
Model No : Velocette SE
Technical File No : TE000026

Issued by:

**Trace Elliot Limited.
Blackwater Trading Estate
The Causeway, Maldon
Essex CM9 4GG.**

PARTS LIST FOR VELOCETTE SE PCB

ISSUE 1 13/12/96 PS

Description	Part Code	Qty	Where Used
PCB	PC00066 issue 1	1	
RESISTORS			
0 ohm link	72-RCZERO	7	R1 (8 OHM) and where shown on PCB
1K5 1/4W	72-RM1K5	4	R10 R14 R15 R22
10K 1/4W	72-RM10K	2	R30 R31
10K 1W	72-RM10K-1WATT	2	R27 R28
27K 1/4W	72-RM27K	1	R5
68K 1/4W	72-RM68K	3	R8 R9 R13
100K 1/4W	72-RM100K	1	R4
100K 1W	72-RM100K-1WATT	3	R11 R23 R24
180K 1/4W	72-RM180K	1	R16
220K 1W	72-RM220K-1WATT	3	R21 R29 R33
470K 1/4W	72-RM470K	3	R3 R6 R32
1M0 1/4W	72-RM1M	3	R2 R12 R17
390R 6W	72-RWW390R-6W	1	R26
1K0 6W	72-RWW1K-6W	1	R18
3K3 4W	72-RWW3K3-4W	1	R25
SEMICONDUCTORS			
1N4007	72-D-IN4007	4	D1 D2 D3 D4
CAPACITORS			
2n2 100V axial	72-C2N2-100VCA	1	C10
100n 100V axial	72-C100N-100VCA	3	C9 C26 C27
100p 1KV ceramic	72-C100P-1KVCD	1	C11
150p 100V ceramic	72-C150P-100VCD	1	C2
220p 1KV ceramic	72-C220P-1KVCD	1	C1
470p 1KV ceramic	72-C470P-1KVCD	1	C3
1n0 1KV ceramic	72-C1000P-1KVCD	2	C16 C17
4n7 1KV ceramic	72-C4700P-1KVCD	4	C18 C19 C24 C25
22n 400V poly box	72-C22N-400VP	4	C4 C5 C8 C12
100n 250V poly box	72-C100N-250VP	1	C6
1u5 35V tant	72-C1.5-35VT	2	C7 C13
2u2 35V tant	72-C2.2-35VT	1	C15
22u 450V elect rad	72-C22-450VER	2	C20 C21
47u 450V elect rad	72-CAP-47450V	1	C22

ISSUE CHANGE DATE	NOTE	ISSUE CHANGE DATE	NOTE	ISSUE CHANGE DATE	NOTE

VELOCETTE SE GUITAR AMPLIFIER (SINGLE ENDED CLASS A)

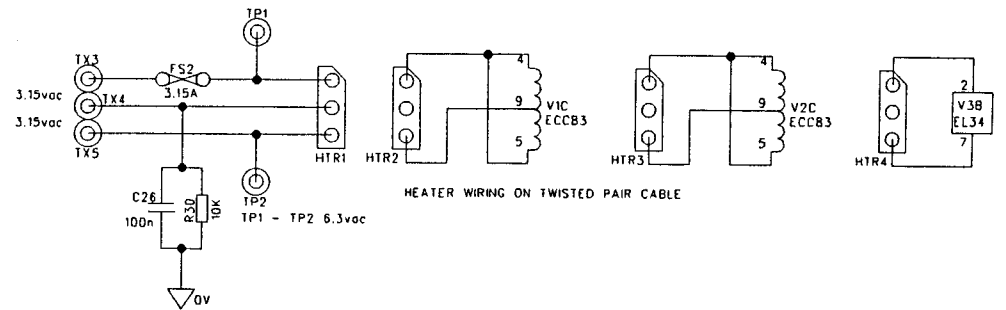
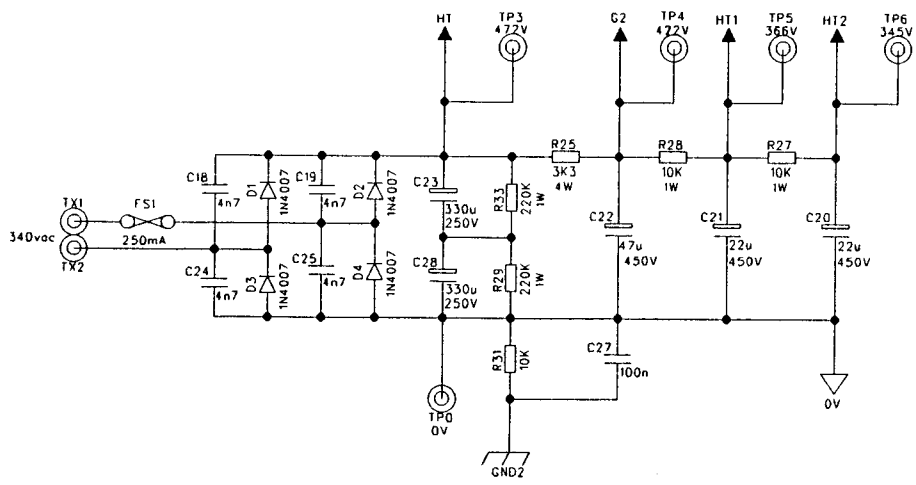
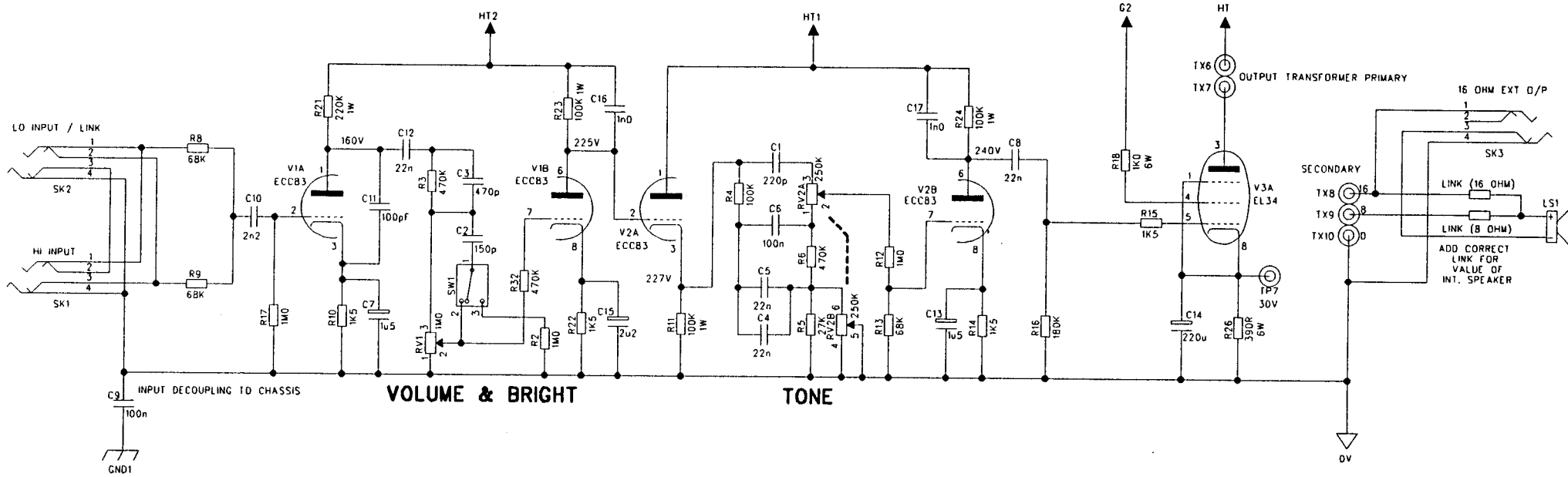

 COMPONENTS USED ARE
 OF AN APPROVED TYPE AND
 MUST BE REPLACED ACCORDINGLY

TITLE	CIRCUIT DIAGRAM	TRACE ELLIOT
PROJECT	VELOCETTE SE GUITAR COMBO	
DRAWING No	C000064	
ISSUE	1	
DATE	3/1/1997	
DRAWN BY	PAUL STEVENS	TRACE ELLIOT LIMITED MALDON ESSEX CM9 7GG GREAT BRITAIN TEL (01621) 855266 FAX (01621) 851975

220u 35V elect rad	72-C220-35VER	1	C14
330u 250V elect rad	72-CAP-330250V	2	C23 C28
CONNECTORS			
3way 0.1"	72-HEAD-3W-2	4	HTR1 HTR2 HTR3 HTR4
CRIMP CONNECTORS	72-CRIMP-PCB-TAB	12	TX1 - 10 LS1 (x2)
TEST PIN			
	73-PIN-TERM	3	TP0 TP1 TP2
SOCKETS			
1/4" MONO JACK SKT	73-SKT-JCKBNBG	3	SK1 SK2 SK3
SWITCHES			
Mini Toggle SPDT vert	73-SWT-M-TGL-PCB	1	SW1
POTENTIOMETERS			
1M0	73-POT-A1M	1	RV1
250K LIN DUAL GANG	73-POT-B250K-DG	1	RV2
FUSE HOLDERS			
Fuse holder PCB 1.25"	72-FUS-HLD-PCB-2	2	FS1 FS2
VALVE BASES			
B9A PCB valve base	73-VAL-SOCKET	2	V1 V2
Octal PCB valve base	73-VAL-SOCKET-2	1	V3
FLYING LEAD			
Cathode heater lead	C00-LEAD-VSE-HTR	1	to be inserted into HTR1, HTR2, HTR3 & HTR4

13 December 1996
Paul Stevens

VELOCETTE SE CIRCUIT DISCRPTION

Please refer to circuit diagram for DC voltages and other information

INPUT SECTION

SK1 and SK2 are the HI and LO sensitivity inputs respectively. When the LO socket is used R8, R9 and R17 act as a potential divider to reduce the input level to the preamp.

C10 has two purposes, firstly to block any DC from the input that may unintentionally be present, this would otherwise change the bias point of the first valve stage, secondly the value of the capacitor has been chosen so that there is a slight roll off of lower frequencies, this prevents the sound from getting too muddy.

PREAMP

V1a is the first gain stage and is configured as a cathode bias, common cathode, voltage amplifier with bypassed cathode resistor for increased gain. C11 has been added for high frequency stability.

R3 and C3 give a slight presence lift and the frequency of the Bright effect is set by C2, which, when switched in, is across pins 2 and 3 of RV1 (Volume). Obviously connected like this the amount of brightness added will decrease as RV1 is turned up.

V1b is the second gain stage configured similar to before, C16 is added across the anode resistor R23 to smooth out the top end.

V2a is configured has a cathode follower, this lowers the impedance to drive the tone network.

The Tone network is passive and controlled by RV2. This is a dual ganged potentiometer, one part of which effectively controls the mids (RV2B) while the other part inversely controls the treble (RV2A).

R12 and R13 act as a potential divider to lower the signal sent to input of the driver stage.

This again is a common cathode voltage amplifier. The output of this drives the control grid (grid 1 - V3 pin 5) of the power valve via R15, the grid stopper resistor, and R16, the grid leak resistor.

POWER STAGE

The output device fitted at the factory will be an EL34. This is configured as a cathode biased, single ended, class A power amplifier with the screen grid connected for pentode operation. However, due to the design of the power stage, the biasing and output transformer, several other octal based power valves can be used, this is fully explained in the operating instructions.

The biasing point and quiescent current is set by R26, which is bypassed by C14 for extra gain.

OUTPUT TRANSFORMER AND SPEAKER CONNECTIONS

The output transformer has secondary taps for 16Ω and 8Ω. The 16Ω tap is used to drive the External Speaker Output, SK3. When a jack plug is inserted into SK3 the internal speaker is disconnected.

The two LINK positions are provided on the PCB so that different impedance internal speakers can be used in production. Depending on whether the internal speaker is 16Ω or 8Ω the correct LINK should be fitted. This has been done purely so that different impedance speakers can be used if there are any problems with supply.

POWER SUPPLIES

Both supplies, HT and ac filament supplies have secondary fusing on the PCB. This is to protect the mains transformer and for approvals.

The HT supply is a very simple bridge rectifier diode network, with 4n7 1KV capacitors across each diode for EMC reasons. This is smoothed by C23 and C28 which provides the main supply to the primary of the output transformer. This is then further smoothed by R25/C22, R28/C21 and R27/C20 to supply the screen grid and preamp.

R29 and R33 have been added to discharge the high voltage capacitors when the unit is turned off and to ensure that the initial smoothing capacitors, C23 and C28, share the voltage across them equally.

The ac heater supply is simply connected via a twisted pair connecting lead to the three valve bases.

Paul Stevens
3 January 1997