

HDD/CD RECORDER

CDR-HD1500

SERVICE MANUAL

- There are two types of CDR-HD1500; one equipped with a hard disc drive and the other without it depending on market areas.
- When accepting a repair order from the user, be sure to inform him/her that the data in HDD cannot be guaranteed.
- CDR-HD1500には販売地域によりハードディスクドライブが搭載されているものと、搭載されていないものがあります。
- 修理依頼を受ける際、HDDのデータは保証できないことをお客様に伝えてください。

IMPORTANT NOTICE

This manual has been provided for the use of authorized YAMAHA Retailers and their service personnel. It has been assumed that basic service procedures inherent to the industry, and more specifically YAMAHA Products, are already known and understood by the users, and have therefore not been restated.

WARNING: Failure to follow appropriate service and safety procedures when servicing this product may result in personal injury, destruction of expensive components, and failure of the product to perform as specified. For these reasons, we advise all YAMAHA product owners that any service required should be performed by an authorized YAMAHA Retailer or the appointed service representative.

IMPORTANT: The presentation or sale of this manual to any individual or firm does not constitute authorization, certification or recognition of any applicable technical capabilities, or establish a principle-agent relationship of any form.

The data provided is believed to be accurate and applicable to the unit(s) indicated on the cover. The research, engineering, and service departments of YAMAHA are continually striving to improve YAMAHA products. Modifications are, therefore, inevitable and specifications are subject to change without notice or obligation to retrofit. Should any discrepancy appear to exist, please contact the distributor's Service Division.

WARNING: Static discharges can destroy expensive components. Discharge any static electricity your body may have accumulated by grounding yourself to the ground buss in the unit (heavy gauge black wires connect to this buss).

IMPORTANT: Turn the unit OFF during disassembly and part replacement. Recheck all work before you apply power to the unit.

CONTENTS

TO SERVICE PERSONNEL	2~4	FORMATTING THE HDD / HDDのフォーマット	27
PREVENTION OF ELECTROSTATIC DISCHARGE	4	ENTERING ID TO MAIN P.C.B. /	
FRONT PANEL	5	メインPCBへのID書き込み	28~29
REAR PANELS	5~6	DISPLAY DATA	30~31
REMOTE CONTROL PANEL	6	IC DATA	32~39
SPECIFICATIONS	6~7	BLOCK DIAGRAM	40
INTERNAL VIEW	7	PRINTED CIRCUIT BOARD	41~44
DISASSEMBLY PROCEDURES / 分解手順	8~15	SCHEMATIC DIAGRAM	45~50
SERVICE CHECK PROCEDURES /		PARTS LIST	51~60
サービスチェック手順	16~19	REMOTE CONTROL	61
INSPECTIONS / 検査	20~25	Parts List for Carbon Resistors	61
UPDATING FIRMWARE /			
ファームウェアの更新	26~27		



このサービスマニュアルは、エコマーク認定の再生紙を使用しています。
This Service Manual uses recycled paper.

© 2005 YAMAHA CORPORATION All rights reserved.

■ TO SERVICE PERSONNEL

- Critical Components Information
Components having special characteristics are marked  and must be replaced with parts having specifications equal to those originally installed.
- Leakage Current Measurement (For 120V Models Only)
When service has been completed, it is imperative to verify that all exposed conductive surfaces are properly insulated from supply circuits.
 - Meter impedance should be equivalent to 1500 ohms shunted by 0.15 μ F.
 - Leakage current must not exceed 0.5mA.
 - Be sure to test for leakage with the AC plug in both polarities.

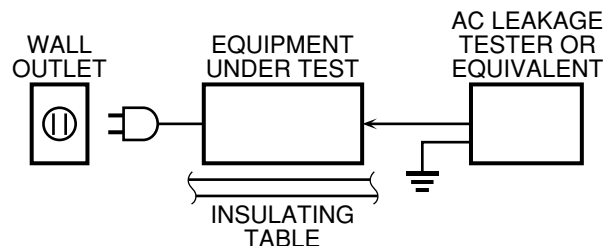

THE COMPACT DISC RECORDER SHOULD NOT BE ADJUSTED OR REPAIRED BY ANYONE EXCEPT PROPERLY QUALIFIED SERVICE PERSONNEL.

WARNING: CHEMICAL CONTENT NOTICE!

The solder used in the production of this product contains LEAD. In addition, other electrical/electronic and /or plastic (where applicable) components may also contain traces of chemicals found by the California Health and Welfare Agency (and possibly other entities) to cause cancer and/or birth defects or other reproductive harm.

DO NOT PLACE SOLDER, ELECTRICAL/ELECTRONIC OR PLASTIC COMPONENTS IN YOUR MOUTH FOR ANY REASON WHATSOEVER!

Avoid prolonged, unprotected contact between solder and your skin! When soldering, do not inhale solder fumes or expose eyes to solder/flux vapor!

If you come in contact with solder or components located inside the enclosure of this product, wash your hands before handling food.

About Lead Free Solder / 無鉛ハンダについて

The P.C.B.s installed in this unit are soldered using the following solder.

本機に搭載されている基板のハンダ付けに使用されているハンダは下記の通りです。

	Side A / A面	Side B / B面
MAIN P.C.B.	Lead Solder / 鉛入りハンダ	Lead Free Solder / 無鉛ハンダ
OPERATION P.C.B.	—	Lead Free Solder / 無鉛ハンダ
OSD P.C.B.	—	Lead Free Solder / 無鉛ハンダ
WCLK P.C.B.	—	Lead Free Solder / 無鉛ハンダ

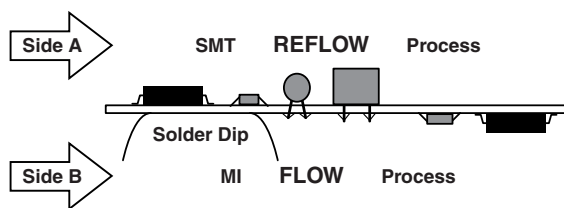

Among some types of lead free solder currently available, it is recommended to use one of the following types for the repair work.

- Sn + Ag + Cu (tin + silver + copper)
- Sn + Cu (tin + copper)
- Sn + Zn + Bi (tin + zinc + bismuth)

無鉛ハンダにはいくつかの種類がありますが、修理時には下記のような無鉛ハンダの使用を推奨します。

- Sn+Ag+Cu (錫+銀+銅)
- Sn+Cu (錫+銅)
- Sn+Zn+Bi (錫+亜鉛+ビスマス)

Caution:

- As the melting point temperature of the lead free solder is about 30°C to 40°C (50°F to 70°F) higher than that of the lead solder, be sure to use a soldering iron suitable to each solder.
- If lead solder must be used, be sure to remove lead free solder from each terminal section of the parts to be replaced and from the area around it completely before soldering, or make sure that the lead free solder and lead solder melt together fully.

注意：

- ① 無鉛ハンダの融点温度は通常の鉛入りハンダに比べ30～40°C程度高くなっていますので、それぞれのハンダに合ったハンダごてをご使用ください。
- ② 鉛入りハンダを使わざるを得ない場合は、あらかじめ交換する部品端子部やその周辺部の無鉛ハンダをすべて取り除くか、あるいは無鉛ハンダと鉛入りハンダが十分に溶けた状態となるようにハンダ付けしてください。

WARNING: Laser Safety

This product contains a laser beam component. This component may emit invisible, as well as visible radiation, which may cause eye damage. To protect your eyes and skin from laser radiation, the following precautions must be used during servicing of the unit.

- 1) When testing and/or repairing any component within the product, keep your eyes and skin more than 30 cm away from the laser pick-up unit at all times. Do not stare at the laser beam at any time.
- 2) Do not attempt to readjust, disassemble or repair the laser pick-up, unless noted elsewhere in this manual.
- 3) CAUTION: Use of controls, adjustments or performance of procedures other than those specified herein may result in hazardous radiation exposure.

Laser Emitting conditions:

1. This device is a Class IIIb laser device.

Class IIIb means

With the protective case removed, exposure to the light output from the laser, either directly or reflected by a mirror, can cause harm to the eyes, but there is no danger to the eyes from exposure to dispersed reflected laser light. (Generally 0.5 W or less)

2. Always wear eyeglasses designed for protection against laser light.
3. Always wear gloves.
4. Have no reflective objects anywhere near this device.
5. Figure A shows from where in this device the laser is emitted.
6. When switching on the power to the device for the first time, always measure the laser power with a laser power meter and check that the power is no greater than the number of Watts in the specifications.
7. Never look directly at the laser light while the laser is emitting light.
8. Do not allow the laser light to shine directly on your skin while the laser is emitting light.

PROTECTION OF EYES FROM LASER BEAM DURING SERVICING

This set employs a laser. Therefore, be sure to carefully follow the instructions below when servicing.

1. Laser Diode Properties

- Material : GaAlAs
- Wavelength : 780 to 787 nm

Pulse durations and max. output at the objective lens of the laser pickup unit

- DC erase mode : Max. 12 mW (Continuous)
- Write mode : Max. 70 mW
(Max. Cycle 98 ns, Min. Cycle 27 ns at Max. Speed)

2. When checking the laser diode emission, keep your eyes more than 30 cm away from the objective lens.

Laser Radiation Point

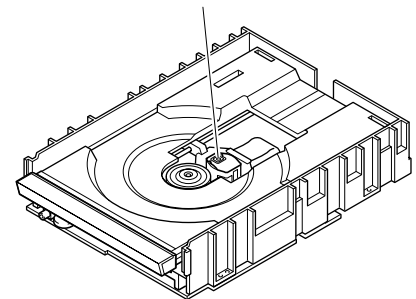
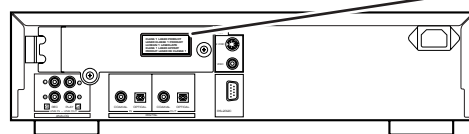

Fig. A

CAUTION

Use of controls or adjustments or performance of procedures other than those specified herein may result in hazardous radiation exposure.



U model

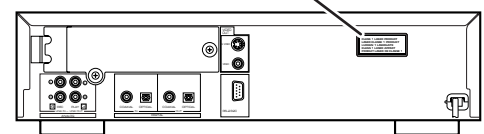

B, G models

VARO!: AVATTAESSA JA SUOJALUKITUS OHITETTAESSA OLET ALTTIINA NÄKYMÄTTÖMÄLLE LASER-SÄTEILYLLE. ÄLÄ KATSO SÄTEESEEN.

VARNING!: OSYNLIG LASERSTRÅLNING NÄR DENNA DEL ÄR ÖPPNAD OCH SPÄRREN ÄR URKOPPLAD. BETRAKTA EJ STRÅLEN.

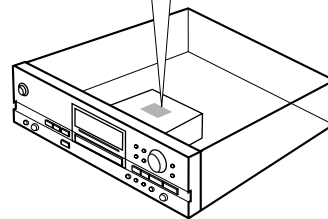

■ PREVENTION OF ELECTROSTATIC DISCHARGE

Some semiconductor (solid state) devices can be damaged easily by static electricity. Such components commonly are called Electrostatically Sensitive (ES) Devices. Examples of typical ES devices are integrated circuits and some field-effect transistors and semiconductor "chip" components. The following techniques should be used to help reduce the incidence of component damage caused by electro static discharge (ESD).

1. Immediately before handling any semiconductor component or semiconductor-equipped assembly, drain off any ESD on your body by touching a known earth ground. Alternatively, obtain and wear a commercially available discharging ESD wrist strap, which should be removed for potential shock reasons prior to applying power to the unit under test.
2. After removing an electrical assembly equipped with ES devices, place the assembly on a conductive surface such as aluminum foil, to prevent electrostatic charge buildup or exposure of the assembly.
3. Use only a grounded-tip soldering iron to solder or unsolder ES devices.
4. Use only an anti-static solder removal device. Some solder removal devices not classified as "anti-static (ESD protected)" can generate electrical charge sufficient to damage ES devices.
5. Do not use freon-propelled chemicals. These can generate electrical charges sufficient to damage ES devices.
6. Do not remove a replacement ES device from its protective package until immediately before you are ready to install it. (Most replacement ES devices are packaged with leads electrically shorted together by conductive foam, aluminum foil or comparable conductive material).
7. Immediately before removing the protective material from the leads of a replacement ES device, touch the protective material to the chassis or circuit assembly into which the device will be installed.
CAUTION: Be sure no power is applied to the chassis or circuit, and observe all other safety precautions.
8. Minimize bodily motions when handling unpackaged replacement ES devices. (Otherwise harmless motion such as the brushing together of your clothes fabric or the lifting of your foot from a carpeted floor can generate static electricity (ESD) sufficient to damage an ES device).

Grounding for electrostatic breakdown prevention

1. Human body grounding:
Use an anti static wrist strap to discharge the static electricity from your body.
2. Work table grounding:
Put a grounded conductive material (sheet) or iron sheet on the area where the optical pickup is placed.

Caution:

The static electricity of your clothes will not be grounded through the wrist strap. So take care not to let your clothes touch the optical pickup.

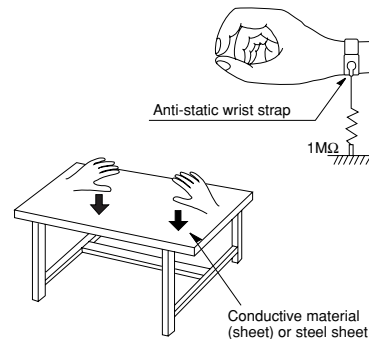

FRONT PANEL

CDR-HD1500

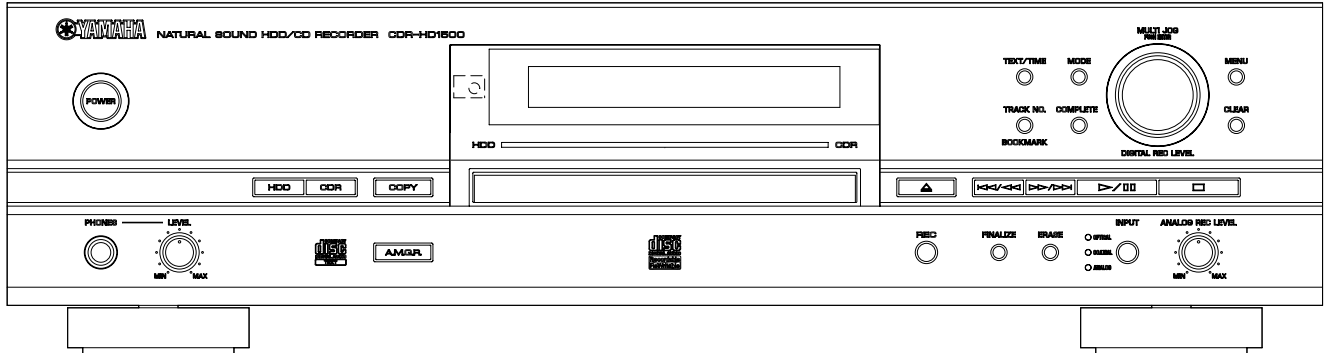

REAR PANELS

CDR-HD1500 (U model)

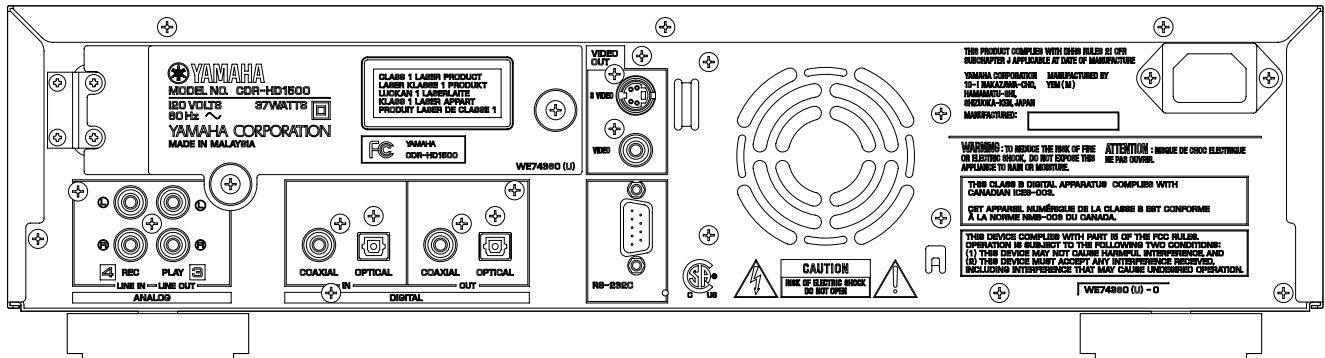

CDR-HD1500 (A model)

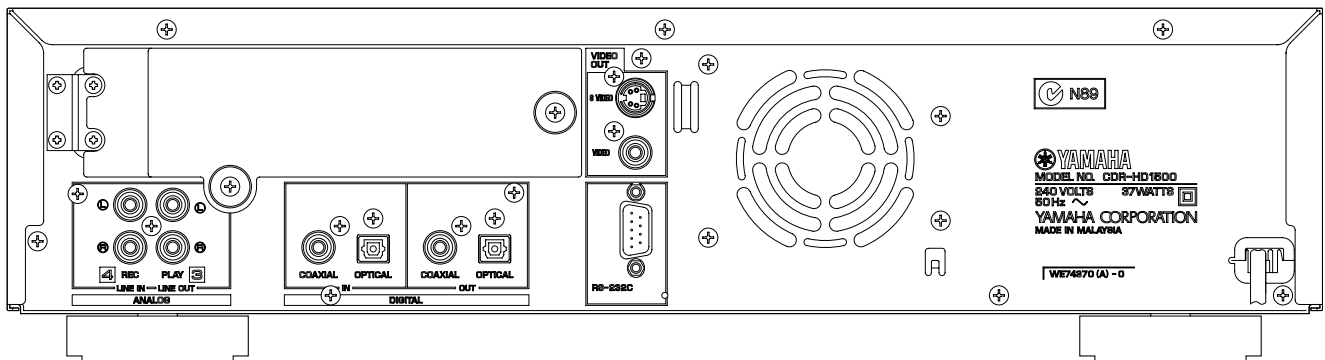

CDR-HD1500 (B, G models)

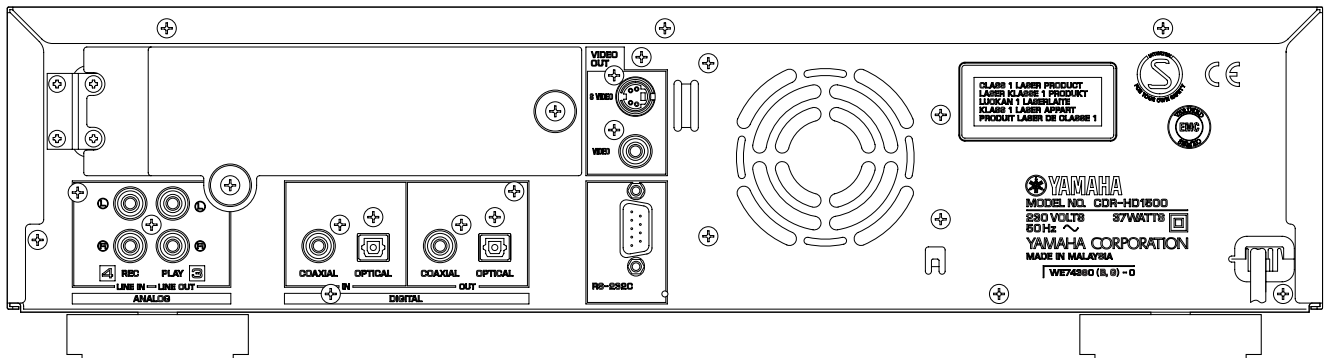

CDR-HD1500 (J model)

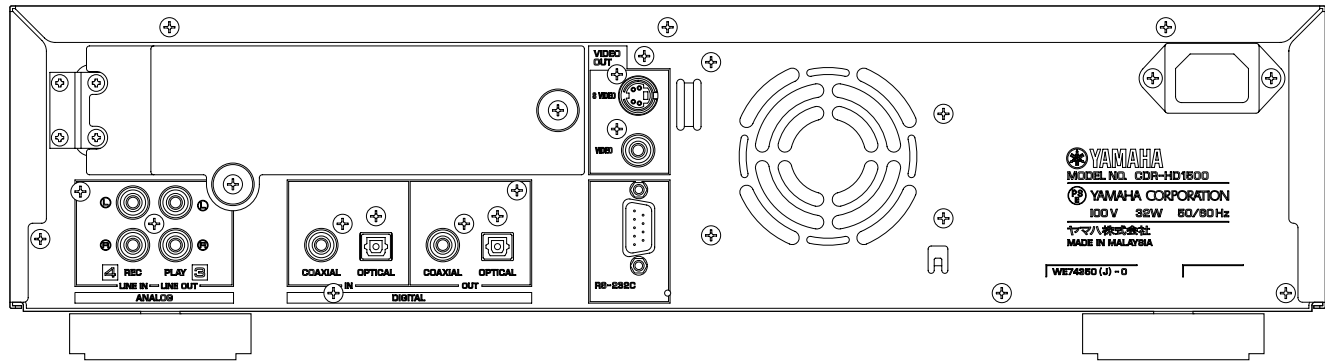

REMOTE CONTROL PANEL

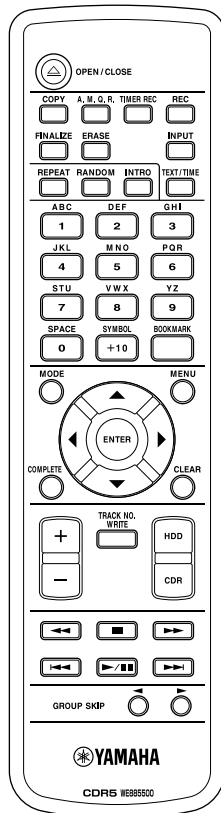

SPECIFICATIONS / 参考仕様

AUDIO PERFORMANCE / オーディオ性能	
Output Level / 出力レベル (1kHz 0dB)	2 ± 0.5 Vrms
Frequency Characteristics / 周波数特性 (EIAJ)	5Hz to 20kHz ± 0.5 dB
Playback Signal to Noise Ratio / 再生SN比 (EIAJ)	105 dB or more
Playback Dynamic Range / 再生ダイナミックレンジ (EIAJ)	99 dB or more
Playback THD + Noise / 再生歪率+雑音 (EIAJ)	0.004 % or less
Recording Signal to Noise Ratio / 録音SN比 (EIAJ)	92 dB or more
Recording Dynamic Range / 録音ダイナミックレンジ (EIAJ)	92 dB or more
Recording THD + Noise / 録音歪率+雑音 (EIAJ)	0.006 % or less

INPUT/OUTPUT / 入出力仕様

Line Output / ライン出力	
Output Level	2 Vrms
Output Resistance	990 ohms
Line Input / ライン入力	
Input Sensitivity	500 mVrms
Input Impedance	24 k-ohms (REC LEVEL Max.)
Digital Output / デジタル出力	
Coaxial Output Level	0.5 Vp-p (75 ohms)
Optical Output Level	-20 dBm
Sampling Frequency	44.1 kHz
Digital Input / デジタル入力	
Coaxial Input Level	0.5 Vp-p (75 ohms)
Optical Input Level	-20 dBm
Input Gain (with Digital Volume)	±12 dB
Input Gain (without Digital Volume)	±0 dB
Sampling Frequency Tolerance	32 kHz, 44.1 kHz, 48 kHz and 96 kHz
Headphone Output / ヘッドホン出力 (Phones Level Max)	
Output Level (-20 dB, 150 ohms load)	330 mVrms

GENERAL / 一般仕様

Model / モデル	HDD / CD recorder
Application Discs / 対応ディスク	.. CDs, CD-Rs for AUDIO, CD-RWs for AUDIO
HDD Capacity / HDD容量	No HDD (Support BigDrive over 137GB, up to 400GB)
Power Supply / 電源電圧	
U model	AC 120 V 60 Hz
A model	AC 240 V 50 Hz
B, G models	AC 230 V 50 Hz
J model	AC 100 V 50/60 Hz

Power Consumption / 消費電力

U, A, B, G models	37 W
J model	32 W
Standby Power Consumption / 待機時消費電力	0 W
Operating Temperature / 動作温度	+ 5 °C ~ + 35 °C
Max. Dimensions / 最大寸法 (W x H x D)	435 x 115.5 x 414.5 mm (17-1/8" x 4-1/2" x 16-5/16") (include legs, terminals and knobs)

Weight / 質量

CDR-HD1500 without HDD	8.2 kg (18 lbs. 1 oz.)
------------------------	------------------------

Panel Color / パネル色

Gold Color	J model
Black Color	U, A, B, G models
Titanium Color	B, G models

Accessories / 付属品

Remote Control x 1, Optical Cable x 1, Audio Pin Cable x 2, Video Pin Cable x 1, Power Cable x 1 (U, J models), Batteries (Manganese Dry) x 2

* Specifications are subject to change without notice due to product improvements.

※ 参考仕様および外観は予告なく変更されることがあります。

U U.S.A. model	A Australian model
B British model	G European model
J Japanese model		

• DIMENSIONS

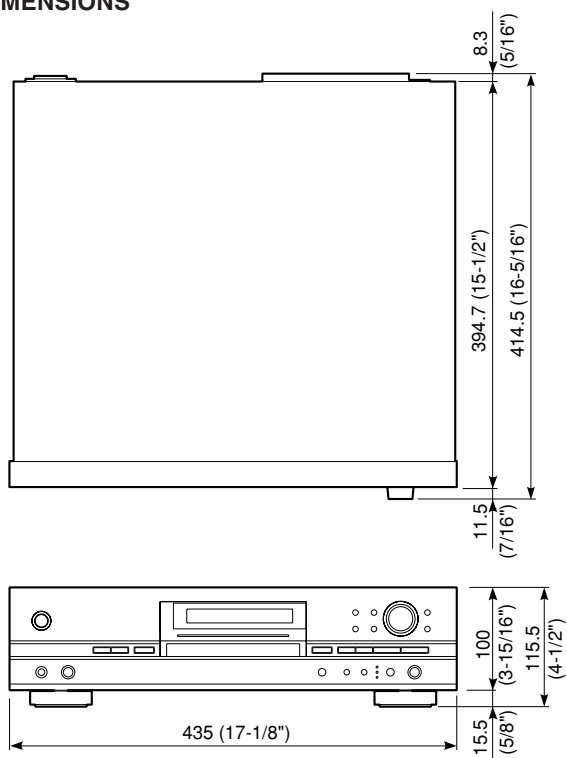

Unit : mm (inch)
 単位: mm (インチ)

■ INTERNAL VIEW

- ① OSD (2) P.C.B. (U, J models)
- ② OPERATION (6) P.C.B.
- ③ OPERATION (7) P.C.B.
- ④ OSD (1) P.C.B.
- ⑤ MAIN P.C.B.
- ⑥ HDD UNIT
- ⑦ OPERATION (1) P.C.B.
- ⑧ WCLK P.C.B.
- ⑨ OPERATION (2) P.C.B.
- ⑩ CD-R/RW DRIVE
- ⑪ OPERATION (3) P.C.B.
- ⑫ OPERATION (4) P.C.B.
- ⑬ OPERATION (5) P.C.B.

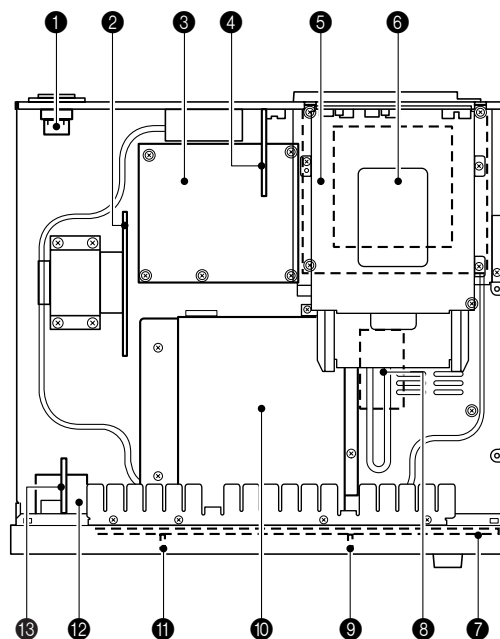

■ DISASSEMBLY PROCEDURES / 分解手順

(Remove parts in the order as numbered.)

(番号順に部品を取り外してください。)

CD-R/RW Drive Replacement

- The CD-R/RW drive must be replaced as a unit. None of its components can be supplied separately.
- After replacing the CD-R/RW drive, be sure to update the CD-R/RW drive firmware to the latest version.

CD-R/RWドライブの交換

- CD-R/RWドライブは、ユニット交換となります。小部品の部品供給はできません。
- CD-R/RWドライブを交換したときには、CD-R/RWドライブファームウェアを最新版に更新してください。

1. Removal of Top Cover

- Turn off the power and disconnect the power plug from the AC power outlet.
- Remove 4 screws (①) and 3 screws (②). (Fig. 1)
- Remove the top cover rearward while lifting it up. (Fig. 1)

1. トップカバーの取り外し

- 電源を切り、AC電源コンセントから電源プラグを抜きます。
- ①のネジ4本、②のネジ3本を外します。(Fig. 1)
- トップカバーを持ち上げながら後方へ外します。(Fig. 1)

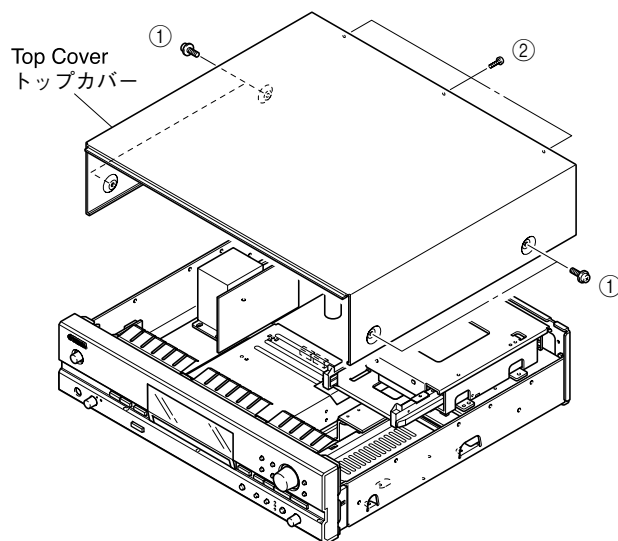

Fig. 1

2. Removal of Sub Chassis Unit, Tray Guide Unit and HDD Tray Unit

- Loosen 2 screws (③) and open the HDD slot door. (Fig. 2)
- Remove 2 screws (④). (Fig. 3)

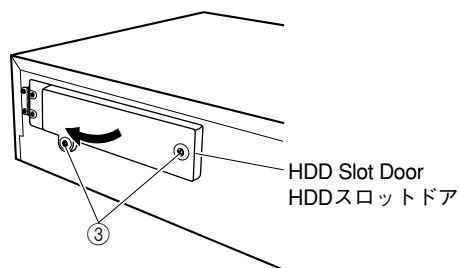

Fig. 2

2. サブシャーシユニット、トレイガイドユニット、HDDトレイユニットの取り外し

- ③のネジ2本をゆるめ、HDDスロットドアを開きます。(Fig. 2)
- ④のネジ2本を外します。(Fig. 3)

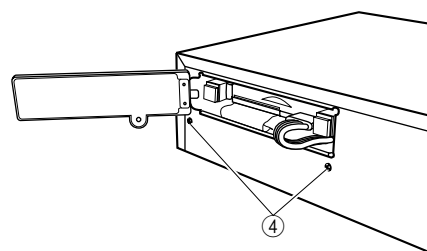

Fig. 3

- Remove 2 screws (⑤). (Fig. 4)
- Remove CB702. (Fig. 4)
- Disconnect the IDE cable from the CDR unit. (Fig. 4)
- Lift the sub chassis unit, tray guide unit and HDD tray unit and disconnect the IDE cable connected to TE1 of the MAIN P.C.B. (Fig. 4)
- Remove the sub chassis unit, tray guide unit and HDD tray unit. (Fig. 4)

- ⑤のネジ2本を外します。(Fig. 4)
- CB702を外します。(Fig. 4)
- CDRユニットからIDEケーブルを外します。(Fig. 4)
- サブシャーシユニット、トレイガイドユニットおよびHDDトレイユニットを持ち上げ、MAIN P.C.B.のTE1に接続されているIDEケーブルを外します。(Fig. 4)
- サブシャーシユニット、トレイガイドユニットおよびHDDトレイユニットを取り外します。(Fig. 4)

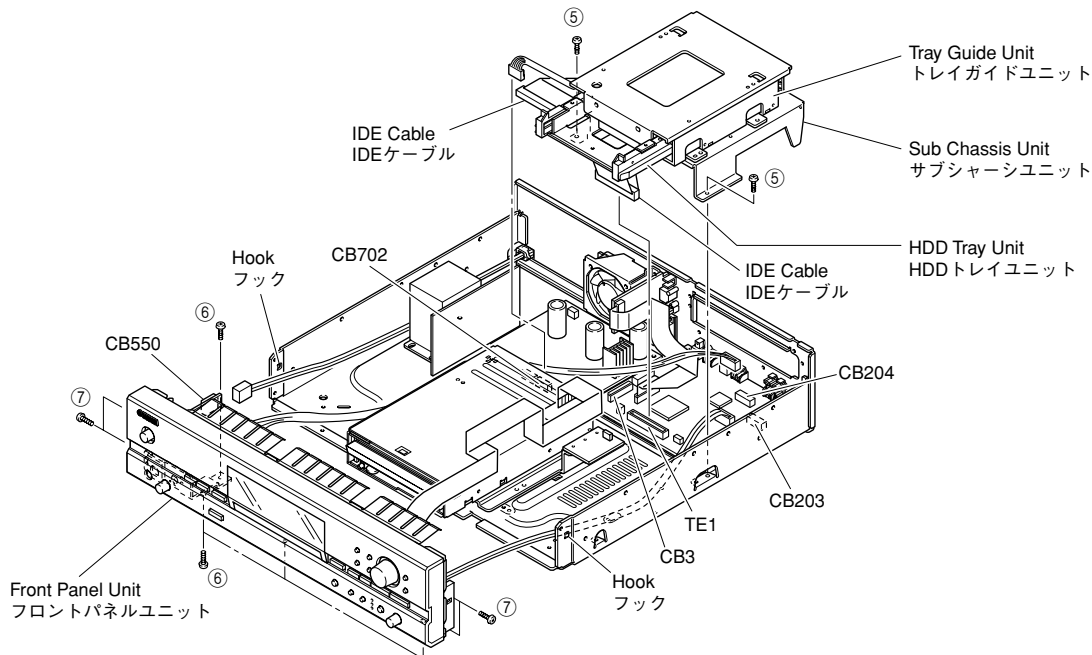

Fig. 4

3. Removal of Front Panel Unit

- Remove 4 screws (⑥) and 4 screws (⑦). (Fig. 4)
- Remove CB3, CB203, CB204 and CB550. (Fig. 4)
- While pushing hooks on both sides of the panel, remove the front panel unit forward. (Fig. 4)

3. フロントパネルユニットの取り外し

- ⑥のネジ4本、⑦のネジ4本を外します。(Fig. 4)
- CB3、CB203、CB204、CB550を外します。(Fig. 4)
- パネル両サイドのフックを押し込みながら、フロントパネルユニットを前方に外します。(Fig. 4)

4. Removal of WCLK P.C.B.

- a. Remove CB1 and CB140. (Fig. 5)
- d. Remove 2 screws (⑧). (Fig. 5)
- c. Remove the WCLK P.C.B.. (Fig. 5)

4. WCLK P.C.B.の取り外し

- a. CB1、CB140を外します。(Fig. 5)
- d. ⑧のネジ2本を外します。(Fig. 5)
- c. WCLK P.C.B.を取り外します。(Fig. 5)

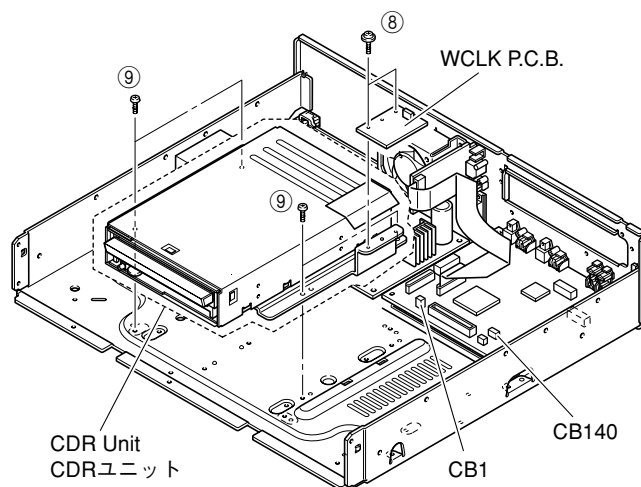

Fig. 5

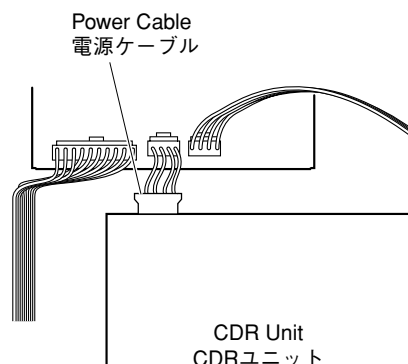

Fig. 6

5. Removal of CDR Unit

- a. Disconnect the power cable from the CDR unit. (Fig. 6)
- b. Remove 4 screws (⑨). (Fig. 5)
- c. Remove the CDR unit. (Fig. 5)

5. CDRユニットの取り外し

- a. CDRユニットから電源ケーブルを外します。(Fig. 6)
- b. ⑨のネジ4本を外します。(Fig. 5)
- c. CDRユニットを取り外します。(Fig. 5)

6. Disassembly of CDR Unit

- a. Remove 4 screws (⑩) and then remove the Support CDR. (Fig. 7)
- b. Push the right side of the manual eject lever to open the tray and remove the lid upward. (Fig. 8)

6. CDRユニットの分解

- a. ⑩のネジ4本を外し、サポートCDRを外します。(Fig. 7)
- b. マニュアルイジェクトレバーの右側を押してトレイを開き、リッドを上方へ外します。(Fig. 8)

7. Assembly of CDR Unit

After replacing the CD-R/RW drive, be sure to update the CD-R/RW drive firmware to the latest version.

- Set the plastic shunt of the new CD-R/RW drive to the master position. (Fig. 9)
- Set the Volume control to the minimum position (fully to the left). (Fig. 8)
- Push the right side of the manual eject lever to open the tray and install the lid. (Fig. 7)
- Install the Support CDR using 4 screws marked (10). (Fig. 7)

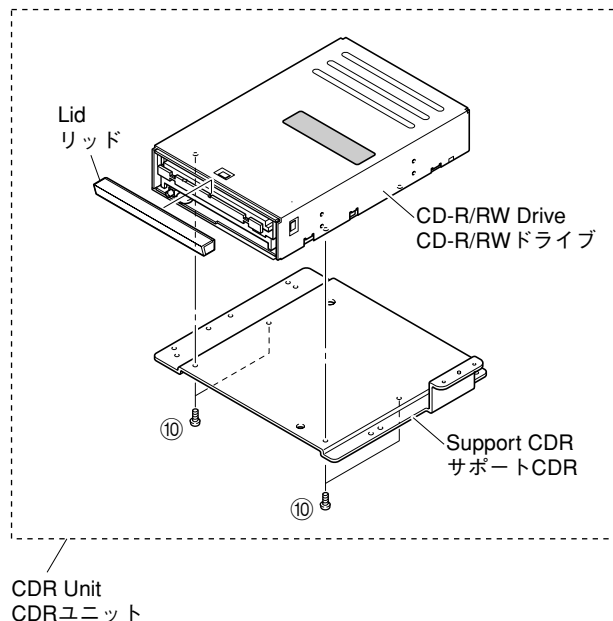
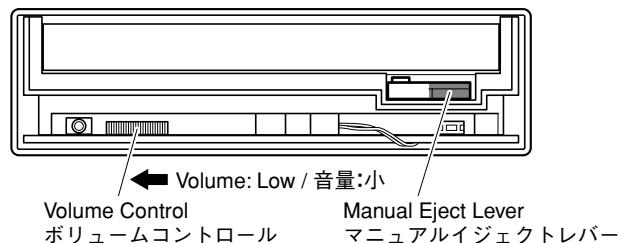

Fig. 7

7. CDRユニットの組立

CD-R/RWドライブを交換したときには、CD-R/RWドライブファームウェアを最新版に更新してください。

- 新しいCD-R/RWドライブのショートピンを、マスターの位置に差し込みなおします。(Fig. 9)
- ボリュームコントロールを最小(左側一杯)に設定します。(Fig. 8)
- マニュアルイジェクトレバーの右側を押してトレイを開き、リッドを取り付けます。(Fig. 7)
- ⑩のネジ4本でサポートCDRを取り付けます。(Fig. 7)



Note) To open the tray, push the right side (shaded section) of the manual eject lever.

注) トレーを開く場合、マニュアルイジェクトレバーの右側(陰影部分)を押します。

Fig. 8

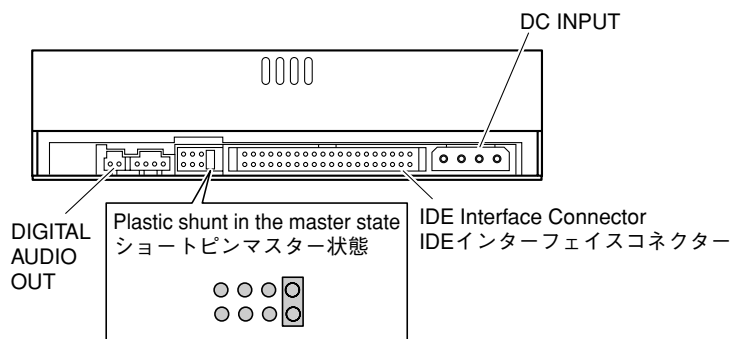

Fig. 9

8. Installation of CDR Unit

- Connect the power cable to the CDR unit. (Fig. 6)
- Install the CDR unit. (Fig. 5)
- Install 4 screws (9). (Fig. 5)

8. CDRユニットの取り付け

- CDRユニットに電源ケーブルを接続します。(Fig. 6)
- CDRユニットを取り付けます。(Fig. 5)
- ⑨のネジ4本を取り付けます。(Fig. 5)

HDD Replacement

- a. Loosen 2 screws (⑪) and open the HDD slot door. (Fig. 10)

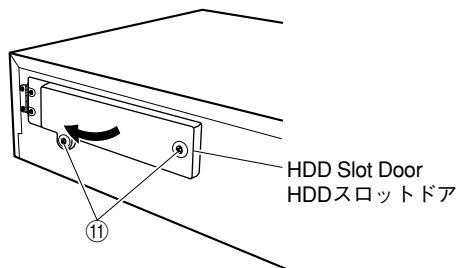

Fig. 10

HDDの交換

- a. ⑪のネジ2本をゆるめ、HDDスロットドアを開きます。(Fig. 10)

- b. Disconnect the IDE cable and power cable from the HDD. (Fig. 11)

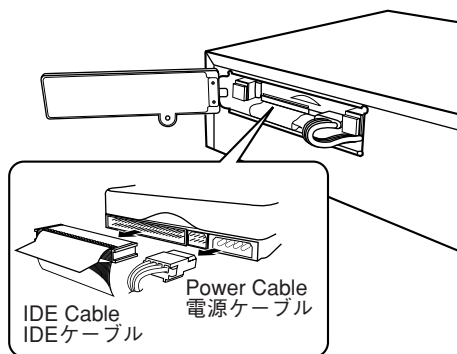
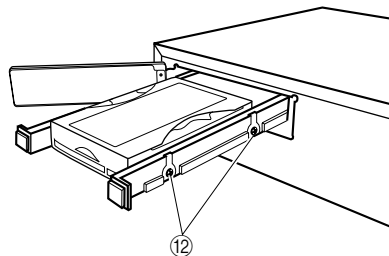

Fig. 11

- b. HDDからIDEケーブルと電源ケーブルを外します。(Fig. 11)

- c. Pull out the HDD tray. (Fig. 12)
- * Be careful not to hook the IDE cable and the power cable over the HDD tray.
 - * Do not apply the excessive force on the HDD tray.
 - * Static electricity can damage the HDD. Be careful not to touch the terminal pins and the P.C.B..
- d. Loosen 4 screws (⑫) and then remove the HDD. (Fig. 12)



(Screws are on the opposite side)
(反対側にもネジがあります。)

Fig. 12

- c. HDDトレイを引き出します。(Fig. 12)
- ※ IDEケーブルや電源ケーブルをHDDトレイに引っかけないようにご注意ください。
 - ※ HDDトレイを無理に引っ張ったり、過度の力を加えないでください。
 - ※ 静電気によりHDDが破損する場合がありますので、HDDのターミナルピンやP.C.B.に触れないようにご注意ください。
- d. ⑫のネジ4本をゆるめ、HDDを取り外します。(Fig. 12)

- e. Set the plastic shunt of the new HDD to slave. (Fig. 13)
- * It is necessary to set the HDD to MASTER or SLAVE when connecting the HDD to the component you plan to use. This unit is designed to operate HDD when it is set to SLAVE. Usually, setting procedure is written on the HDD itself.

Example: When setting the WD800AB model
例: Western Digital社製WD800ABの場合

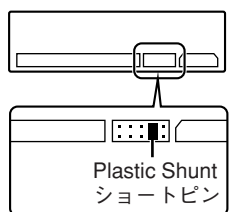

The HDD is set to slave by setting the plastic shunt at the second position from right of the jumper switch.
ジャンパースイッチの右から2番目の位置にショートピンを差し込むと、スレーブに設定される

- e. 新しいHDDのショートピンを、スレーブの状態にします。(Fig. 13)
- ※ IDE/ATAタイプのHDDはお使いになる機器と接続するときに、マスターまたはスレーブに設定する必要があります。本機で使用する場合は、スレーブに設定すると作動するように設計されています。設定方法については、通常HDD本体に記載されています。

Example: When setting the ST3160021A model
例: Seagate社製ST3160021Aの場合

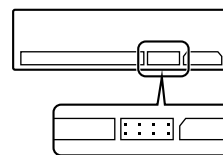

The HDD is set to slave by setting no plastic shunt at any position of the jumper switch.
ショートピンをどの位置にも差し込まないと、スレーブに設定される

Fig. 13

- f. Install a new HDD on the tray using 4 screws (12) . (Fig. 12)
- * HDD is a very sensitive device. Be careful not to give any shock to it.
- g. Push the HDD tray and connect the IDE cable and the power cable. (Fig. 14)
- * Make sure that the connectors are in the correct direction, and connect the cables securely.
- * Static electricity can damage the HDD. Be careful not to touch the terminal pins and the circuit board.
- * Do not apply excessive force on the HDD tray.
- h. Close the HDD slot door and tighten the 2 screws (13) on the HDD slot door. (Fig. 15)

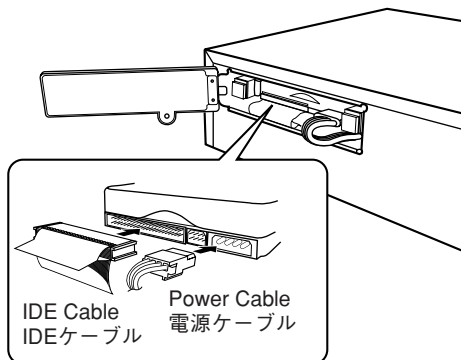

Fig. 14

- f. 新しいHDDをトレイに置き、12のネジ4本で固定します。(Fig. 12)
- ※ HDDは衝撃に弱い機器ですので、振動や衝撃を加えないようご注意ください。
- g. HDDトレイを奥に押し込み、IDEケーブルと電源ケーブルを差し込みます。(Fig. 14)
- ※ コネクターの向きが正しいか確認のうえ、しっかりと差し込んでください。
- ※ 静電気によりHDDが破損する場合がありますので、HDDのターミナルピンやP.C.B.に触れないようご注意ください。
- ※ HDDを無理に押し込んだり、過度の力を加えないでください。
- h. HDDスロットドアを閉じて、13のネジ2本をしめます。(Fig. 15)

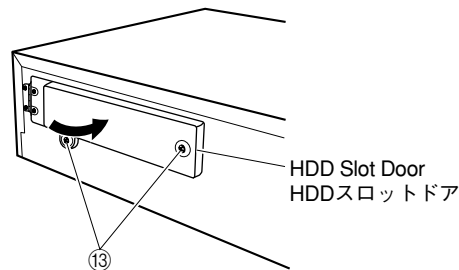

Fig. 15

P.C.B. Operation Check

- Remove the Top Cover.
- Loosen 2 screws (14) on the HDD slot door and open the HDD slot door. (Fig. 16)
- Remove 2 screws (15). (Fig. 17)

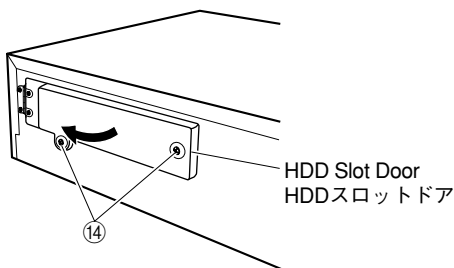

Fig. 16

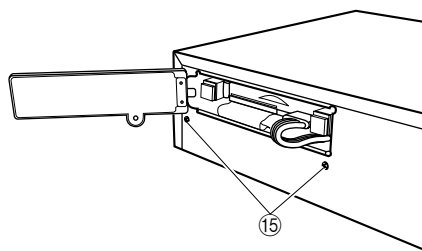

Fig. 17

- Remove 2 screws (16). (Fig. 18)
- Remove CB702. (Fig. 18)
- Disconnect the IDE cable from the CDR unit. (Fig. 18)
- Lift the sub chassis unit, tray guide unit and HDD tray unit and disconnect the IDE cable connected to TE1 of the MAIN P.C.B. (Fig. 18)
- Remove the sub chassis unit, tray guide unit and HDD tray unit. (Fig. 18)

- 16のネジ2本を外します。(Fig. 18)
- CB702を外します。(Fig. 18)
- CDRユニットからIDEケーブルを外します。(Fig. 18)
- サブシャーシユニット、トレイガイドユニットおよびHDDトレイユニットを持ち上げ、MAIN P.C.B.のTE1に接続されているIDEケーブルを外します。(Fig. 18)
- サブシャーシユニット、トレイガイドユニットおよびHDDトレイユニットを取り外します。(Fig. 18)

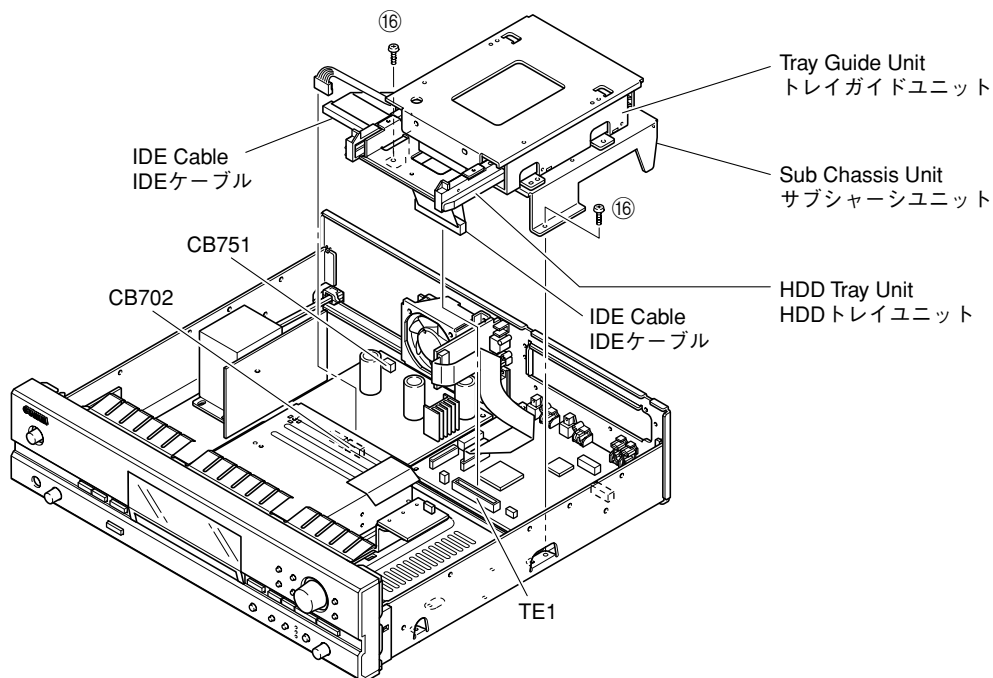

Fig. 18

- i. Remove 3 screws (17) and 2 jack screws (18). (Fig. 19)
- j. Remove the OSD P.C.B.. (Fig. 20)
- k. Remove 4 screws (19). (Fig. 20)
- l. Remove 5 screws (20). (Fig. 19)
- m. Remove the MAIN P.C.B.. (Fig. 20)

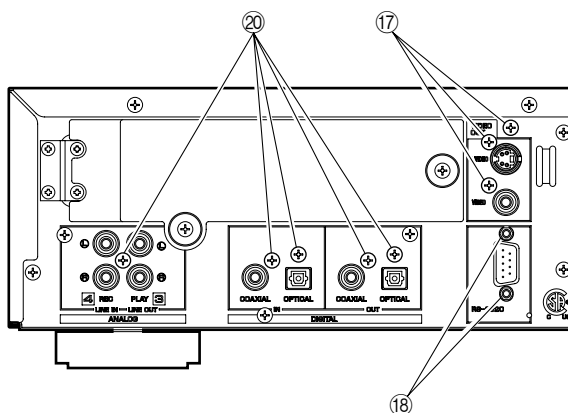

Fig. 19

- i. 17のネジ3本、18のジャックスクリュー2本を外します。(Fig. 19)
- j. OSD P.C.B.を取り外します。(Fig. 20)
- k. 19のネジ4本を外します。(Fig. 20)
- l. 20のネジ5本を外します。(Fig. 19)
- m. MAIN P.C.B.を取り外します。(Fig. 20)

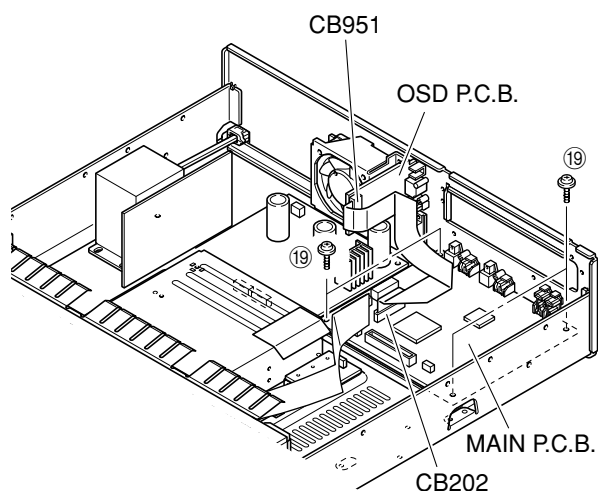

Fig. 20

- n. Using an extension cable, connect TE1 of the MAIN P.C.B. and the CDR Unit. (Fig. 21)
Extension cable for pin No. 40 (600mm): V9589500
- o. Connect ST901 of the OSD P.C.B. and the rear panel with lead wires or the like for grounding. (Fig. 21)
- p. Connect G1 and G2 of the MAIN P.C.B. and the chassis with a lead wire or the like for grounding. (Fig. 21)

- o. MAIN P.C.B.のTE1とCDRユニット間をサービス用延長ケーブルで接続します。(Fig. 21)
40P 600mm延長ケーブル: V9589500
- p. OSD P.C.B.のST901とリアパネルをリード線等でGND接続します。(Fig. 21)
- q. MAIN P.C.B.のG1、G2とシャーシをリード線等でGND接続します。(Fig. 21)

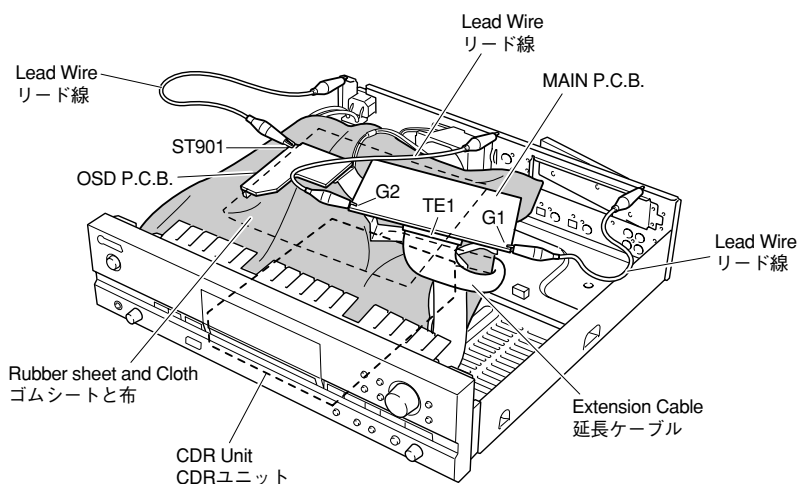

Fig. 21

Caution:

After replacing the MAIN P.C.B. or IC11 (MAIN P.C.B.), it is necessary to update the firmware.

注意:

MAIN P.C.B.またはIC11 (MAIN P.C.B.)を交換した場合は、ファームウェアの更新が必要です。

■ SERVICE CHECK PROCEDURES

When the main unit fails to operate

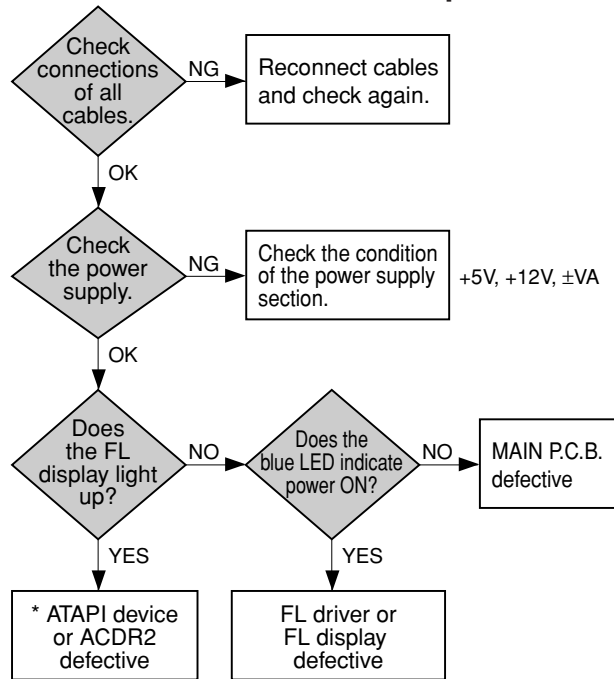

* ATAPI device means HDD and CD-R/RW drive.

■ サービスチェック手順

本体が動作しない

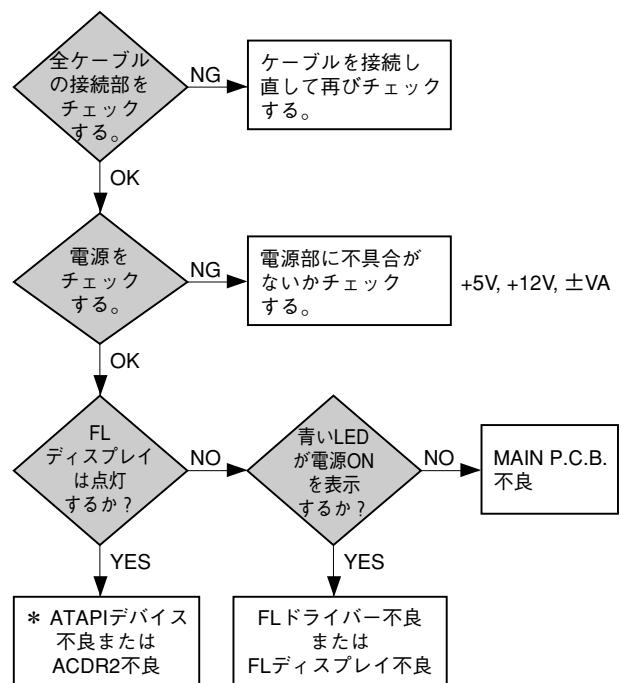

* ATAPIデバイスは、HDDおよびCD-R/RWドライブを意味します。

When MAIN P.C.B. is defective

The MAIN P.C.B. consists of the following 3 blocks.

- 1) CPU, DRAM and Flash Memory
- 2) ACDR2 and DIR5
- 3) CODEC and analog

MAIN P.C.B.不良

MAIN P.C.B.は、下記の3ブロックで構成されています。

- 1) CPU、DRAMおよびフラッシュメモリー
- 2) ACDR2とDIR5
- 3) CODECとアナログ

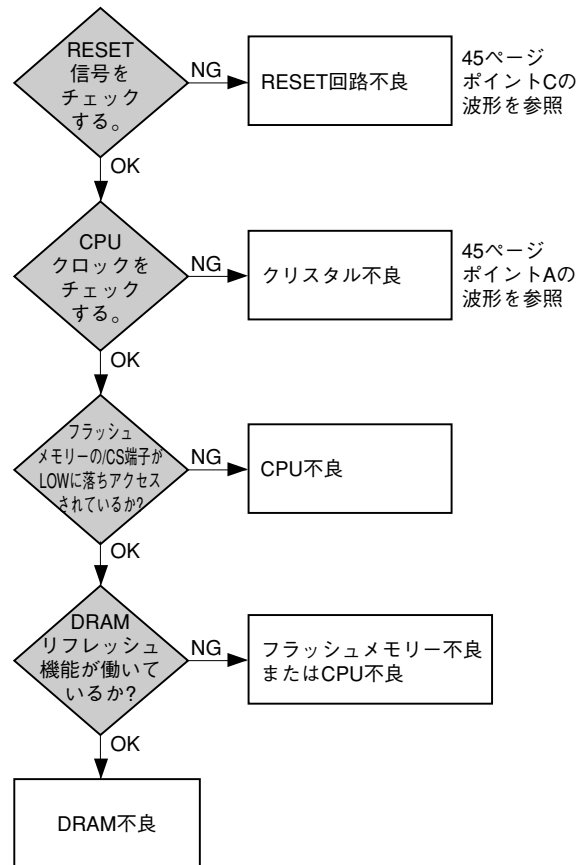
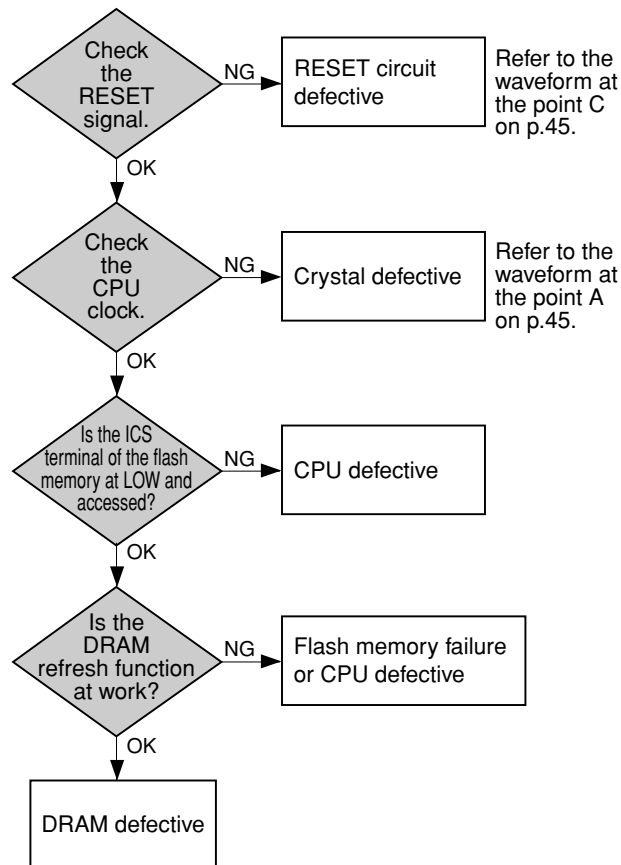

When ATAPI device is defective

Possible symptom varies depending on the defective point.

- “Drive Check” is displayed.
- Only the scale of the level meter is displayed.
- Switching the drive switch causes hang-up to occur.
- Abnormal mechanical noise is heard from the unit.

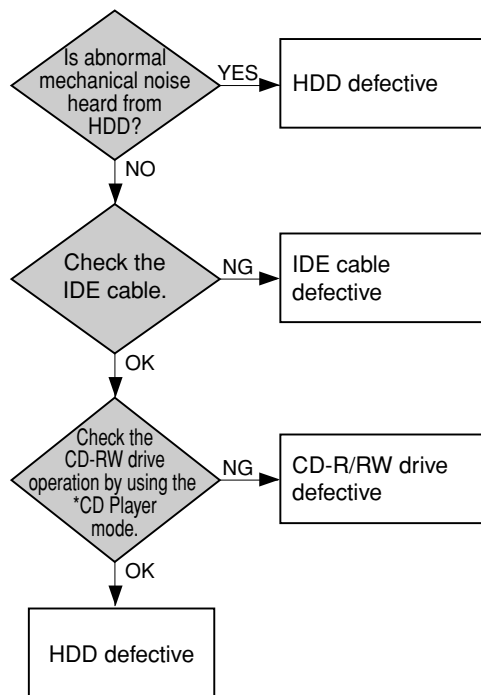

* For the CD Player mode, refer to the description of the CD Player mode.

ATAPIデバイス不良

不良個所により以下の症状が考えられます。

- 「Drive Check」と表示される。
- レベルメーターの目盛りだけが表示される。
- ドライブのスイッチを切り替えるとハングアップする。
- 装置から異常な機械音が聞こえる。

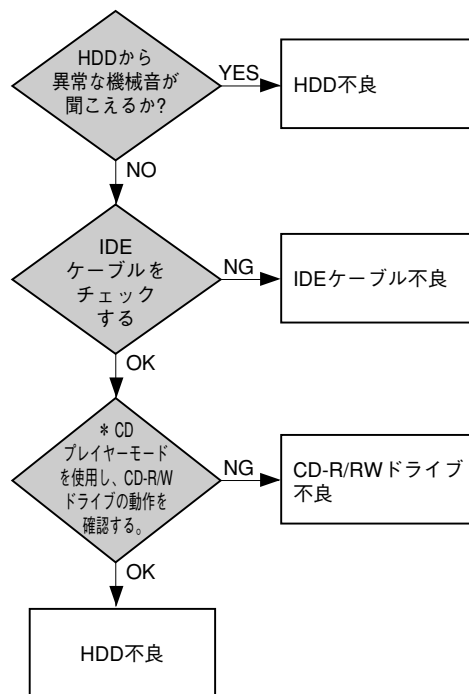

* CDプレイヤーモードについては、“CDプレイヤーモード”を参照してください。

CD player mode

Using the CD player mode, the CD-R/RW drive can be operated independently.

- 1) Turn off the power.
- 2) Disconnect the IDE cable connected to HDD.
- 3) Turn on the power.

After the same display as at the normal start-up, “Wait” flashes and after about 30 seconds, the CD player mode is activated.

In order to make the start-up time shorter, turn on the power while pressing the “□” key and “MENU” key simultaneously and then keep pressing the “□” key and “MENU” key.

- 4) Press the “△” key to open the tray and load a CD on the tray.
- 5) Press the “△” key to close the tray.
- 6) Press the “▷/□” key.
- 7) Check that the CD sound is heard properly from the LINE OUT terminal.

CDプレイヤーモード

CDプレイヤーモードを使用することにより、CD-R/RWドライブを単独で動作させることができます。

- 1) 電源を切ります。
- 2) HDDに接続されているIDEケーブルを外します。
- 3) 電源を入れます。

通常の起動時の表示の後、「Wait」が点滅します。約30秒後、CDプレイヤーモードが起動します。

なお、起動時間を短縮するには、“□”キーと“MENU”キーを同時に押しながら電源を入れ、“□”キーと“MENU”キーを押し続けます。

- 4) “△”キーを押してトレイを開き、CDをトレイに乗せません。
- 5) “△”キーを押し、トレイを閉じます。
- 6) “▷/□”キーを押します。
- 7) LINE OUT端子にCDの音声は正常に出力されることを確かめます。

ACDR2 Check

By using the mode 1, mode 2 and mode 3 of the P.C.B. test mode, the operation of the ACDR2 can be checked.

In Mode 1, the analog signal input/output operation is checked.

In Mode 1, it is possible to check the A/D and D/A converter function of CODEC, signal flow in ACDR2, operation of the low pass filter in the input/output circuit.

In Mode 2, input of the optical digital signal and digital output operation are checked.

The ACDR2 decodes the sub-code and displays the track No. and the track time. To test this decoding function, the digital output of the CD player is used.

In Mode 3, the digital coaxial signal input and analog output operation are checked.

Starting the P.C.B. Test Mode

- 1) Turn off the power.
- 2) Remove the HDD unit for the convenience of the work of the next step 3). (p. 14)
- 3) Short between pins No.1 and No.2 of the CB5. (MAIN P.C.B., E3 in p.41)
- 4) Short between J909 and J913. (OSD P.C.B., C4 in p.44)
- 5) Turn on the power.
- 6) The P.C.B. test mode is activated and "TEST mode PCB" is displayed.

Mode 1 Operation Check

- 1) Set to Mode 1 by pressing the "◀◀/◀◀" key. "test mode 1" is displayed.
- 2) Enter the analog signal through ANALOG LINE IN.
Input signal: Sine wave, 1kHz, 150mV (-14.2dBm)
- 3) Set the ANALOG REC LEVEL volume to the MAX position.
- 4) Check the analog signal output at ANALOG LINE OUT.
Output Level : 775mV (0dBm)

ACDR2不良

P.C.B.テストモードのモード1、モード2およびモード3を使用することにより、ACDR2の動作を確認することができます。

モード1では、アナログ信号の入・出力動作を確認します。モード1ではCODECのA/DおよびD/Aコンバーター機能、ACDR2内の信号の流れ、入・出力回路のローパスフィルターの動作を確認することができます。

モード2では、光デジタル信号の入力とデジタル出力動作を確認します。

ACDR2はサブコードを復号し、トラックNo.とトラック時間を表示します。この復号機能をテストするためにCDプレイヤーのデジタル出力を使用します。

モード3では、デジタル同軸信号入力とアナログ出力動作を確認します。

P.C.B.テストモードの起動

- 1) 電源を切ります。
- 2) 次の3)の作業のためにHDDユニットを外します。(14ページ)
- 3) CB5の1ピンと2ピン間をショートします。(MAIN P.C.B. 41ページのE3)
- 4) J909とJ913間をショートします。(OSD P.C.B. 44ページのC4)
- 5) 電源を入れます。
- 6) P.C.B.テストモードが起動し、「TEST mode PCB」が表示されます。

モード1動作確認

- 1) "◀◀/◀◀"キーを押し、モード1に設定します。「test mode 1」が表示されます。
- 2) ANALOG LINE INからアナログ信号を入力します。
入力信号：サイン波、1kHz、150mV (-14.2dBm)
- 3) ANALOG REC LEVELボリュームはMAXに設定します。
- 4) ANALOG LINE OUTに出力されるアナログ信号を確認します。
出力レベル：775mV(0dBm)

Signal flow diagram of Mode 1

モード1の信号フロー図

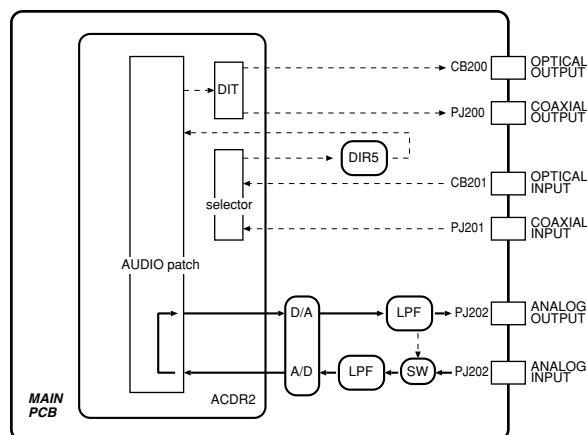

Mode 2 Operation Check

- 1) Set to Mode 2 by pressing the “▷▷/▷▷” key. “test mode 2” is displayed, followed by “mod2 00 00 00”.
- 2) Apply the digital optical output signal of the CD player into DIGITAL OPTICAL IN.
- 3) Check the track No. and track time on display.
- 4) Check the output signal at DIGITAL OUT.

モード2動作確認

- 1) “▷▷/▷▷”キーを押し、モード2に設定します。「test mode 2」が表示された後、「mod2 00 00:00」が表示されます。
- 2) DIGITAL OPTICAL INにCDプレイヤーの光出力信号を入力します。
- 3) トラックNo.およびトラック時間表示を確認します。
- 4) DIGITAL OUT出力信号を確認します。

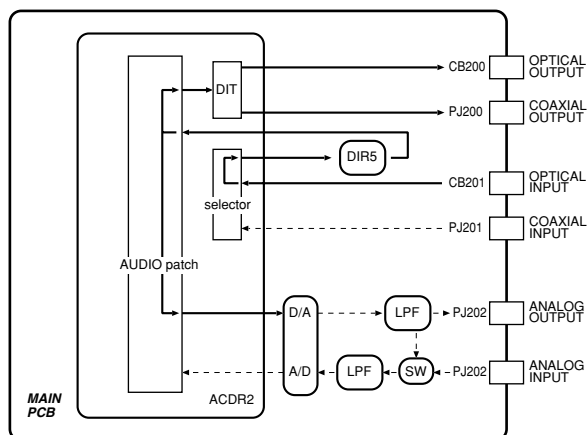
Signal flow diagram of Mode 2.**モード2の信号フロー図****Mode 3 Operation Check**

- 1) Press the “▷/□□” key to set to Mode 3. “test mode 3” is displayed followed by “mod3 00 00:00”.
- 2) Enter the digital coaxial output signal of the CD player to DIGITAL COAXIAL IN.
- 3) Check the track No. and track time display.
- 4) Check the ANALOG LINE OUT output signal.

モード3動作確認

- 1) “▷/□□”キーを押し、モード3に設定します。「test mode 3」が表示された後、「mod3 00 00:00」が表示されます。
- 2) DIGITAL COAXIAL INにCDプレイヤーのデジタル同軸出力信号を入力します。
- 3) トラックNo.およびトラック時間表示を確認します。
- 4) ANALOG LINE OUT出力信号を確認します。

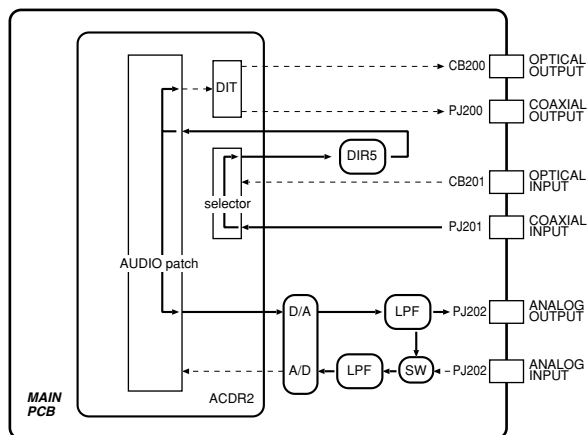
Signal flow diagram of Mode 3.**モード3の信号フロー図**

INSPECTIONS

Instruments Required for Inspection

- CD test disc (YEDS-18: TX911730)
- CD-RW disc (TDK CD-RW AUDIO 74min [XA74N])
- CD player with digital output (optical/coaxial) function (used as a digital signal generator)
- AV amplifier with digital input (optical/coaxial) function (used as a D/A converter)
- Analog signal generator
- Oscilloscope
- Level meter
- Distortion meter
- HDD for jigs (HDD UNIT FOR SERVICE: AAX39420)

Step	Item	Mode	Input signal	Disc	Check method and standard
1	Display	Test mode		No disc	<ol style="list-style-type: none"> 1. Turn on the power while pressing the "◀◀/▶▶" key and the "▶▶/▶▶" key. Keep pressing the "◀◀/▶▶" key and the "▶▶/▶▶" key until "TEST mode" is displayed. 2. Check that all FL display units light up and go off properly by pressing the "COPY" key. 3. Check each key for proper response as follows. When any key other than POWER, HDD, CDR and COPY is pressed, the corresponding key name should be displayed. Also, JOG Forward should appear when the MULTI JOG knob is turned clockwise and JOG Rewind should appear when it is turned counterclockwise. <p>Also, each of operation indicator LEDs of CDR and HDD lights in blue and orange alternately every time the MULTI JOG knob is turned.</p>

Step	Item	Mode	Input signal	Disc	Check method and standard
2	D/A Converter	Normal mode		YEDS-18	<ol style="list-style-type: none"> 1. Turn on the power. (In normal mode) 2. Load the CD test disc (YEDS-18: TX911730). 3. Play track 2 (1kHz, 0dB). 4. Check that the output level of LINE OUT (ANALOG) is $2 \pm 0.5V_{rms}$. 5. Check that the distortion factor (1kHz) is 0.01% or less. 6. Play tracks 3 (20Hz) and 6 (20kHz) and check that the frequency response is $0 \pm 1.5dB$. 7. Play track 7 and check that S/N is 100dB or more.

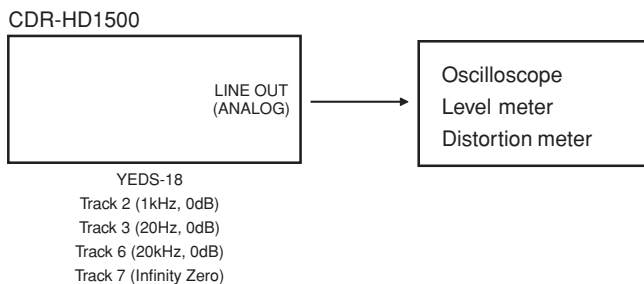

■ 検査

準備するもの

CDテストディスク(YEDS-18 : TX911730)

CD-RWディスク(TDK CD-RW AUDIO 74min(XA74N))

デジタル出力(光/同軸)を持ったCDプレーヤー(デジタル信号発生器として使用します)

デジタル入力(光/同軸)を持ったAVアンプ(D/A変換器として使用します)

アナログ信号発振器、オシロスコープ、レベルメーター、歪率計

治具用HDD (HDD UNIT FOR SERVICE: AAX39420)

ステップ	項目	モード	入力信号	ディスク	確認方法&規格
1	ディスプレイ	テストモード		No disc	<ol style="list-style-type: none"> ◀◀/◀◀キーと▶▶/▶▶キーを押しながら電源を入れる。「TEST mode」が表示されるまで、◀◀/◀◀キーと▶▶/▶▶キーを押し続ける。 COPYキーで全灯/全消灯ができることを確認する。 キーレスポンスを確認する。POWER、HDD、CDR、COPY以外のキーを押すと、そのキーの名前が表示される。MULTI JOGを時計方向に回すと「JOG Forward」と表示され、反時計方向に回すと「JOG Rewind」と表示される。また、CDRとHDDの動作状態表示用LEDが、それぞれMULTI JOGを回すごとに青↔橙が点灯する。

ステップ	項目	モード	入力信号	ディスク	確認方法&規格
2	DAコンバータ	製品モード		YEDS-18	<ol style="list-style-type: none"> パワーオンする。(製品モード) CDテストディスク(YEDS-18)をセットする。 トラック2 (1kHz, 0dB)を再生する。 LINE OUT (ANALOG)の出力レベルが、$2 \pm 0.5V_{rms}$であることを確認する。 歪率が0.01%以下であることを確認する。 トラック3 (20Hz)とトラック6 (20kHz)を再生して、周波数特性が$0 \pm 1.5dB$であることを確認する。 トラック7を再生して、S/Nが100dB以上であることを確認する。

CDR-HD1500

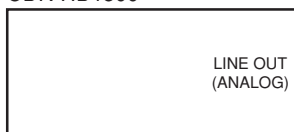

YEDS-18
Track 2 (1kHz, 0dB)
Track 3 (20Hz, 0dB)
Track 6 (20kHz, 0dB)
Track 7 (Infinity Zero)

Step	Item	Mode	Input signal	Disc	Check method and standard
3	A/D converter	DAC mode	LINE IN (ANALOG) 1kHz, 20Hz, 20kHz 500mVrms	No disc	<ol style="list-style-type: none"> Press the "MENU" key. Turn the "MULTI JOG" knob to select "DAC mode" then press the "MULTI JOG" knob. Set the INPUT selector to the ANALOG position. Apply a 1kHz, 500mVrms analog signal to the LINE IN (ANALOG). Demodulate the digital signal of DIGITAL OUT (COAXIAL) to analog. Adjusting the ANALOG REC LEVEL control knob, check that the demodulated signal level can be set to 1Vrms. At this time, check that the REC LEVEL control knob is close to the 12 o'clock position. Check that the distortion factor is 0.02% or less. Check that the S/N is 82dB or more. (Input shorted, REC LEVEL max.) Check that the frequency response (at 20Hz and 20kHz) is 0 ± 1.5dB. Press the "□" key to return to the normal mode.

Step	Item	Mode	Input signal	Disc	Check method and standard
4	Copying CD ▷ HDD	Normal mode		CD	<ol style="list-style-type: none"> Load a CD on the tray and close the tray. Press the "COPY" key once to go to COPY Standby mode, blue LED of CDR and orange LED of HDD begin to blink slowly. Press the "▷ / □□" key to start copying. Press the "□" key to stop copying. Recommended recording time is over 1 track time. Press the "HDD" key to select HDD. Press the "▷ / □□" key to play back the recorded track and confirm it recorded correctly. Press the "△" key, remove the disc and close the tray. Check the disc and track numbers with recorded contents for testing. Press the "HDD" key to select HDD. Press the "MENU" key and turn the "MULTI JOG" knob to select "Disc Edit" and then press the "MULTI JOG" knob. Turn the "MULTI JOG" knob to select "Disc Erase" and then press the "MULTI JOG" knob. Select the disc No. with recorded contents for testing by turning the "MULTI JOG" knob and press it. Press the "COMPLETE" key to erase the selected disc. If there are more than one discs with recorded contents for testing, repeat Steps 11, 12 and 13. <p>* If it is allowed to format HDD, execute formatting instead of performing Steps 8 and after.</p>

ステップ	項目	モード	入力信号	ディスク	確認方法&規格
3	ADコンバータ	DACモード	LINE IN (ANALOG) 1kHz, 20Hz, 20kHz 500mVrms	No disc	<ol style="list-style-type: none"> MENUキーを押し、MULTI JOGを回して「DAC mode」を選び、MULTI JOGを押し。 INPUTセレクターをANALOGにする。 LINE IN (ANALOG)に1kHz, 500mVrmsのアナログ信号を加える。 DIGITAL OUT (COAXIAL)のデジタル信号をアナログに復調する。 ANALOG REC LEVELツマミを調整して、復調した信号レベルが1Vrmsに設定できることを確認する。 このとき、REC LEVELツマミは12時付近であることを確認する。 歪率が0.02%以下であることを確認する。 S/Nが82dB以上であることを確認する。 (入カショート、REC LEVEL最大) 周波数特性(20Hzと20kHz)が0±1.5dBであることを確認する。 □キーを押し、製品モードに戻る。

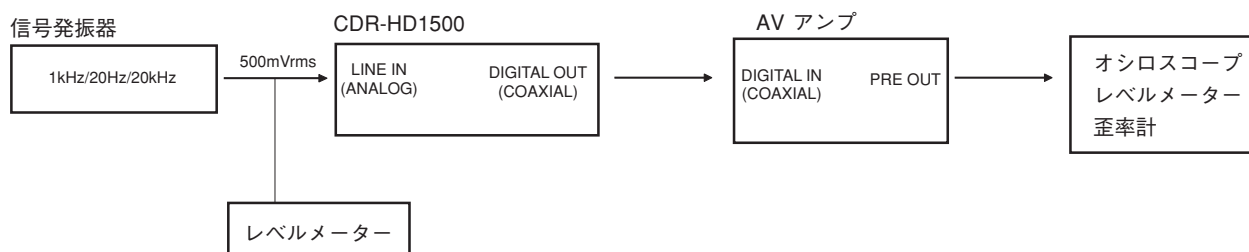

ステップ	項目	モード	入力信号	ディスク	確認方法&規格
4	CDからHDDへのコピー	製品モード		CD	<ol style="list-style-type: none"> CDをトレーにセットし、トレーをクローズする。 COPYキーを1回押ししてHDD COPY standby modeにする。CDRの青LEDとHDDの橙LEDがゆっくり点滅を始める。 ▷/□キーを押ししてコピーを開始する。 1トラック以上録音し、□キーで停止させる。 HDDキーを押ししてHDDを選択する。 ▷/□キーを押しして録音したトラックを再生し、正しく録音されていることを確認する。 △キーを押ししてディスクを取り出し、トレーをクローズする。 テストのために録音したディスクおよびトラックの番号を確認する。 HDDキーを押しして、HDDを選択する。 MENUキーを押し、MULTI JOGを回して「Disc Edit」を選択し、MULTI JOGを押し。 MULTI JOGを回して「Disc Erase」を選択し、MULTI JOGを押し。 テストのために録音したディスクNo.をMULTI JOGで選択し、MULTI JOGを押し。 COMPLETEキーを押し、選択したディスクを消去する。 テストのために録音したディスクが複数ある場合には、11より繰り返す。 ※ HDDをフォーマットして良い場合には、上記8以降を行わずにフォーマットを実施してください。

Step	Item	Mode	Input signal	Disc	Check method and standard
5	Recording External Input ▷ HDD	Normal mode		No disc	<p>Execute HDD formatting when HDD for the jig is installed. (Refer to "FORMATTING THE HDD" on page 27.)</p> <ol style="list-style-type: none"> 1. Press the "HDD" key to select HDD. 2. Press the "REC" key, and "0:00" is displayed. 3. Press the "INPUT" key to select the input source to be recorded. 4. Adjust the recording level. 5. Press the "▷/□" key to start recording. 6. Continue recording for 20 seconds or longer and press the "□" key to stop recording. 7. Turn the "MULTI JOG" knob to select the track of above recording. 8. Press the "▷/□" key to play back the track and confirm it recorded correctly.

CD player

DIGITAL OUT
&
ANALOG OUT

→

CDR-HD1500

DIGITAL IN
&
ANALOG IN

Step	Item	Mode	Input signal	Disc	Check method and standard
6	Copying HDD ▷ CD-RW	Normal mode		CD-RW	<p>Make recording onto HDD for 20 seconds or longer in advance. (Refer to Step 5.)</p> <ol style="list-style-type: none"> 1. Load an unfinalized CD-RW disc on the tray and close the tray. After 7 or 8 seconds, "0" is displayed. 2. Press the "COPY" key twice. The mode is set to CDR COPY standby mode and blue LED of HDD and orange LED of CDR blink slowly. 3. Press the "MENU" key, turn the "MULTI JOG" knob to select "Copy Method" and press the "MULTI JOG" knob. The blue LED of HDD and orange LED of CDR blink quickly at the same time. 4. Turn the "MULTI JOG" knob to select "Analog Copy" and press the "MULTI JOG" knob. "Copy Method" is displayed. 5. Press the "MENU" key to set to the HDD COPY standby mode. The blue LED of HDD and orange LED of CDR blink slowly. 6. Press the "▷/□" key to start recording. <ul style="list-style-type: none"> • "OPC Adjust" is displayed first. • Then, "Image 0%" is displayed and count starts. • After reaching 99%, copying is started. • When copying is completed, "1" is displayed. 7. Press the "CDR" key to select CD-R/RW drive. 8. Press the "▷/□" key to play back the recorded track and confirm it recorded correctly. 9. Press the "△" key and remove the CD-RW disc.

ステップ	項目	モード	入力信号	ディスク	確認方法&規格
5	外部入力からHDDへの録音	製品モード		No disc	<p>治具用HDDを取り付けた場合には、HDDのフォーマットを行う。 (「HDDのフォーマット」27ページ参照)</p> <ol style="list-style-type: none"> HDDキーを押しHDDを選択する。 RECキーを押す。 「0:00」が表示される。 INPUTキーを押して録音する入力ソースを選択する。 録音レベルを調整する。 ▶/□キーを押して録音を開始する。 20秒以上録音し、□キーを押して録音を停止する。 MULTI JOGを回して、先ほど録音したトラックを選択する。 ▶/□キーを押して再生し、正しく録音されていることを確認する。

CDプレーヤー
 DIGITAL OUT
 &
 ANALOG OUT

→

CDR-HD1500
 DIGITAL IN
 &
 ANALOG IN

ステップ	項目	モード	入力信号	ディスク	確認方法&規格
6	HDDからCD-RWへのコピー	製品モード		CD-RW	<p>あらかじめHDDに20秒以上録音しておく。 (ステップ5参照)</p> <ol style="list-style-type: none"> ファイナライズされていないCD-RWディスクをトレイにセットし、トレイをクローズする。 7~8秒後、「0」が表示される。 COPYキーを2回押す。 CDR COPY standby modeになり、HDDの青LEDとCDRの橙LEDがゆっくり点滅する。 MENUキーを押し、MULTI JOGを回して「Copy Method」を選択し、MULTI JOGを押す。 HDDの青LEDとCDRの橙LEDが同時に速く点滅する。 MULTI JOGを回して「Analog Copy」を選択し、MULTI JOGを押す。 「Copy Method」が表示される。 MENUキーを押してCDR COPY standby modeにする。 HDDの青LEDとCDRの橙LEDがゆっくり点滅する。 ▶/□キーを押して録音を開始する。 <ul style="list-style-type: none"> 始めに「OPC Adjust」が表示される。 次に「Image 0%」が表示され、カウントされる。 99%表示後、コピーを開始する。 コピー終了後、「1」と表示される。 CDRキーを押しCD-R/RW driveを選択する。 ▶/□キーを押して録音したトラックを再生し、正しく録音されていることを確認する。 △キーを押してCD-RWディスクを取り出す。

■ UPDATING FIRMWARE

1. Overview

After replacing the MAIN P.C.B. or the IC11(MAIN P.C.B) or the CD-R/RW Drive, the firmware must be updated.

Note that there are two types of firmware; system control firmware and CD-R/RW drive firmware.

This equipment is capable of upgrading both of the firmware by using the firmware CD-R.

Detailed information on supply of the firmware CD-R will be provided in Service News.

2. Confirmation of the Firmware Versions

1. Press the “□” key.
2. Press the “MENU” key to enter MENU mode.
3. Turn the “MULTI JOG” knob to select “Sys. Utility”. Press the “MULTI JOG” knob.
4. “Firm. Version” is displayed. Press the “MULTI JOG” knob.
The system control firmware version is displayed with its compiled date and time.
The characters shown are scrolled once.
5. Turn the “MULTI JOG” knob clockwise, the CD-R/RW drive firmware version is displayed.
6. Turn the “MULTI JOG” knob clockwise again, the HDD name is displayed.
7. Press the “MENU” key three times to return to the normal playback mode.

3. Firmware Update Procedures

1. Press the “□” key.
2. Press the “CDR” key to select the CD-R/RW drive.
3. Press the “△” key to open the disc tray. Load the “firmware CD-R” on the disc tray and press the “△” key to close the tray.
Wait to finish reading the disc.
4. Press the “MENU” key to enter MENU mode.
5. Turn the “MULTI JOG” knob to select “Sys. Utility”. Press the “MULTI JOG” knob. “Firm. Version” is displayed.
6. Turn the “MULTI JOG” knob to select “Firm. Update”. Press the “MULTI JOG” knob.
7. “Main FW (CD)” is displayed. Three types of upgrade mode can be selected by turning the “MULTI JOG” knob.
 - (1) “Main FW (CD)” means upgrading the system control firmware from CD-ROM.
 - (2) “CDRW FW (CD)” means upgrading the CD-R/RW drive firmware from CD-ROM.
 - (3) “All FW (CD)” equal executing “Main FW (CD)” and “CDRW FW (CD)” at the same time.
8. Choose one mode and press the “MULTI JOG” knob.
9. “Push PLAY KEY” is displayed. Press the “▷/□□” key to start update.
10. “Downloading” is displayed. **NEVER TURN OFF THE POWER WHILE “Downloading” IS DISPLAYED.**

■ ファームウェアの更新

1. 概要

MAIN P.C.B.またはIC11(MAIN P.C.B)またはCD-R/RWドライブを交換した場合、ファームウェアの更新が必要です。ファームウェアには、システムコントロール ファームウェアとCD-R/RWドライブ ファームウェアの2つがあります。

ファームウェアCD-Rを使って、これら両方のファームウェアを更新することができます。

なお、ファームウェアCD-Rの供給に関する詳細は、サービスニュースでお知らせします。

2. ファームウェアのバージョンの確認

1. “□”キーを押します。
2. “MENU”キーを押すと、MENUモードに入ります。
3. “MULTI JOG”つまみを回して、「Sys. Utility」を選びます。“MULTI JOG”つまみを押します。
4. 「Firm. Version」と表示されたら、“MULTI JOG”つまみを押します。システムコントロール ファームウェアのバージョンが、コンパイルされた日時と一緒に表示されます。
5. “MULTI JOG”つまみを右にまわすと、CD-R/RWドライブファームウェアのバージョンが表示されます。
6. “MULTI JOG”つまみをさらに右に回すと、HDDの名前が表示されます。
7. “MENU”キーを3回押して、通常の再生モードに戻します。

3. ファームウェアの更新手順

1. “□”キーを押します。
2. “CDR”キーを押して、CD-R/RWドライブを選びます。
3. “△”キーを押して、ディスクトレイを開きます。ディスクトレイにファームウェアCD-Rをのせてから、“△”キーを押してトレイを閉めます。ディスクの読みとりが終わるまで待ちます。
4. “MENU”キーを押すと、MENUモードに入ります。
5. “MULTI JOG”つまみを回して、「Sys. Utility」を選びます。“MULTI JOG”つまみを押します。「Firm. Version」と表示されます。
6. “MULTI JOG”つまみを回して、「Firm Update」を選びます。“MULTI JOG”つまみを押します。
7. 「Main FW(CD)」と表示されます。“MULTI JOG”つまみをまわすことにより、3種のアップグレードモードを選ぶことができます。
 - (1)「Main FW(CD)」は、システムコントロール ファームウェアのアップグレードを行います。
 - (2)「CDRW FW(CD)」は、CD-R/RWドライブ ファームウェアのアップグレードを行います。
 - (3)「All FW(CD)」は、「Main FW(CD)」と「CDRW FW(CD)」を同時に実行します。
8. モードを一つ選んで、“MULTI JOG”つまみを押します。
9. 「Push PLAY KEY」と表示されます。“▷/□□”キーを押すと、更新が始まります。
10. 「Downloading」が表示されます。「Downloading」が表示されている間は、絶対に電源を切らないでください。

- “Main FW (CD)” takes about 20 seconds.
 - “CDRW FW (CD)” takes about 40 seconds.
 - “All FW (CD)” takes about 55 seconds.
11. When finishing the upgrade, “Complete” is displayed and this equipment is rebooted.
 12. Confirm that the firmware version has been changed from old to new.
 13. If the firmware versions stay old, retry above updating procedures.

- 「Main FW(CD)」は、約20秒かかります。
 - 「CDRW FW(CD)」は、約40秒かかります。
 - 「All FW(CD)」は、約55秒かかります。
11. アップグレードが終了すると、「Complete」と表示されて、本機はリブートします。
 12. ファームウェアのバージョンが、旧バージョンから新バージョンに変わったことを確認します。
 13. ファームウェアのバージョンが旧バージョンのままであったら、上記の更新手順を再度実行します。

■ FORMATTING THE HDD

1. After installing a new HDD, be sure to execute formatting according to the following procedure.

- a. Turn on the power, and “Format Start?” is displayed.
- b. Press the “▶/□□” key, and “Format Really” is displayed.
- c. Press the “▶/□□” key, and “Push PLAY KEY” is displayed.
- d. Press the “▶/□□” key, and “Wait” flashes. After some time, formatting is executed. It takes about 15 seconds before formatting is completed.
- e. When formatting is completed, “Format OK” is displayed, followed by the same message as after turning on the power.
- f. Turn off the power.

2. After installing an HDD which has been used for another CDR-HD1500, execute formatting according to the following procedure.

- a. Turn on the power.
- b. Press the “HDD” key to select HDD and then press the “MENU” key.
- c. Turn the “MULTI JOG” knob to select “HDD Utility” and then press the “MULTI JOG” knob.
- d. Turn the “MULTI JOG” knob to select “HDD Format” and then press the “MULTI JOG” knob. Then “Initialize ?” is displayed.
- e. Press the “▶/□□” key, and “Format Really” is displayed.
- f. Press the INPUT key, and “Wait” flashes. After some time, formatting is executed. It takes about 15 seconds before formatting is completed.
- g. When formatting is completed, “Format OK” is displayed, followed by the same message as after turning on the power.
- h. Turn off the power.

■ HDDのフォーマット

1. 新品のHDD を取り付けた場合は、以下の手順でフォーマットします。

- a. 電源を入れると、「Format Start?」と表示されます。
- b. “▶/□□”キーを押すと、「Format Really」と表示されます。
- c. “▶/□□”キーを押すと、「Push PLAY KEY」と表示されます。
- d. “▶/□□”キーを押すと、「Wait」が点滅し、しばらくするとフォーマットが始まります。フォーマットが完了するまで約15秒かかります。
- e. フォーマットが完了すると「Format OK」と表示され、その後電源を入れたときの表示になります。
- f. 電源を切ります。

2. 他のCDR-HD1500で使用していたHDD を取り付けた場合は、以下の手順でフォーマットします。

- a. 電源を入れます。
- b. “HDD”キーを押してハードディスクを選択し、「MENU」キーを押します。
- c. “MULTI JOG”つまみを回して「HDD Utility」を選択し、「MULTI JOG」つまみを押します。
- d. “MULTI JOG”つまみを回して「HDD Format」を選択し、「MULTI JOG」つまみを押すと「Initialize ?」と表示されます。
- e. “▶/□□”キーを押すと「Format Really」と表示されます。
- f. “INPUT”キーを押すと、「Wait」が点滅し、しばらくするとフォーマットが始まります。フォーマットが完了するまで約15秒かかります。
- g. フォーマットが完了すると「Format OK」と表示され、その後電源を入れたときの表示になります。
- h. 電源を切ります。

■ ENTERING ID TO MAIN P.C.B.

After replacing the MAIN P.C.B. or IC11 (MAIN P.C.B.), ID must be entered.

Preparation: Take the measure against electrostatic discharge before the work.

Items required: IC Writing Board with Jig Cable (2P)
Parts No.: WA045500

■ メインPCBへのID書き込み

MAIN P.C.B.またはIC11 (MAIN P.C.B.)の交換後には、必ずIDを書き込む必要があります。

準備：作業の前に必ず静電気対策を実施してください。

用意するもの：IC書き込み治具[治具ケーブル(2P)含む]
部品No.：WA045500

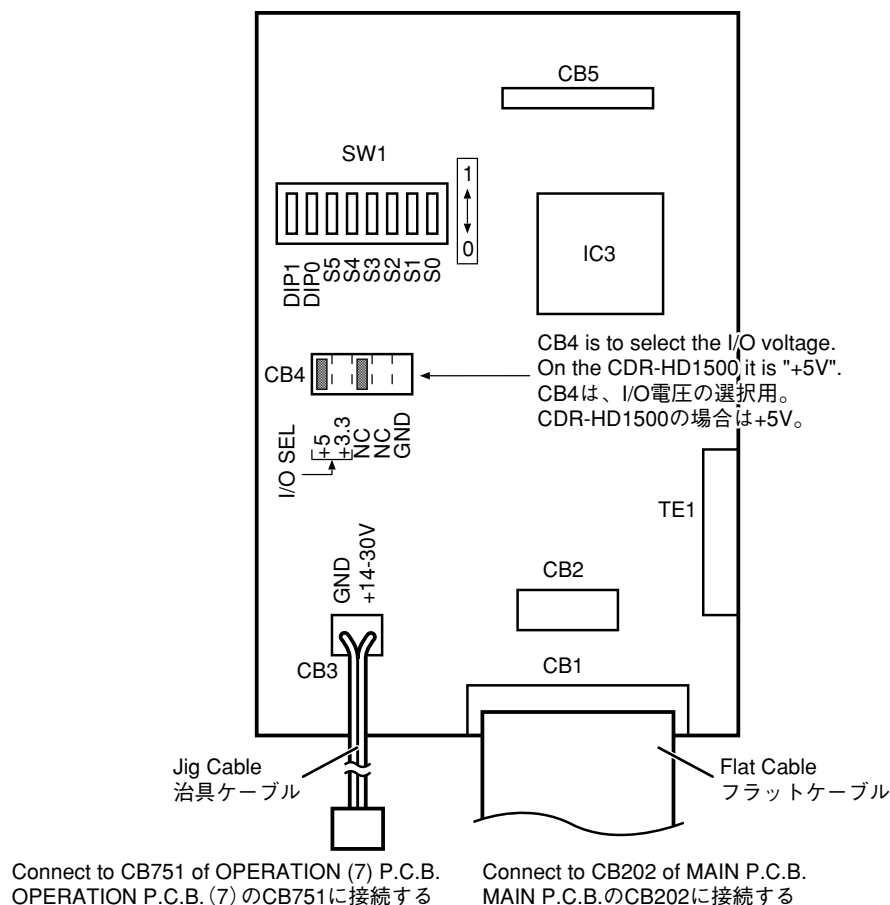

Fig. 1 (Jig P.C.B. / 治具P.C.B.)

Installing Jig

- 1) Turn off the power.
- 2) Remove the top cover.
- 3) Remove CB951 of OSD P.C.B.. (Fig. 20 on page 15)
- 4) Using the flatcable disconnected in Step 3), connect CB1 of the jig P.C.B. to CB202 of MAIN P.C.B..
- 5) Connect CB3 of the jig P.C.B. to CB751 of OPERATION (7) P.C.B. with jig cable (2P). (Fig. 18 on page 14)
- 6) Set the DIP switch of the jig P.C.B. as shown in Fig. 2.

治具の取り付け

- 1) 電源を切ります。
- 2) トップカバーを外します。
- 3) OSD P.C.B.のCB951を外します。(15ページのFig. 20)
- 4) 治具P.C.B.のCB1とMAIN P.C.B.のCB202を、手順3)で外したフラットケーブルで接続します。
- 5) 治具P.C.B.のCB3とOPERATION (7) P.C.B.のCB751を治具ケーブル(2P)で接続します。(14ページのFig. 18)
- 6) 治具P.C.B.のDIPスイッチをFig. 2のように設定します。

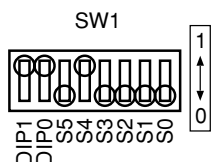

Fig. 2 (DIP switch setting / DIPスイッチの設定)

Operation Procedure

- 1) Turn on the power.
“Sys ID write” menu and “sys ID check” menu are added automatically to “System Utility”.
- 2) Press the “MENU” key.
- 3) Turn the “MULTI JOG” knob to select “Sys Utility” and then press the “MULTI JOG” knob.
- 4) Turn the “MULTI JOG” knob to select “Sys ID Write” and then press the “MULTI JOG” knob.
- 5) Turn the “MULTI JOG” knob to select “CDR-HD1500” depending on the model and then press the “MULTI JOG” knob.
- 6) “Y000000XZ” is displayed. Input the serial number indicated on the rear panel of the main unit or inside of the chassis.
 - 6)-1 Turn the “MULTI JOG” knob clockwise.
When the “MULTI JOG” knob is turned clockwise, characters are displayed in the order of alphabetical capital letters, alphabetical lower case letters, numbers, and symbols. Select the character you wish to use for the title.
 - 6)-2 Press the “MULTI JOG” knob to confirm the selected character.
The cursor moves to the next space. Repeat steps 1 and 2 until the title is complete.

Correcting the characters

Move the cursor to the character to be corrected by pressing “◀◀/◀◀” or “▶▶/▶▶” key (“◀◀” or “▶▶” key on the remote control). Press “CLEAR” key to cancel the character before a new character is entered. Then enter and confirm the new character.

- 7) Press the “COMPLETE” key.
- 8) “Complete” is displayed. This completes the writing procedure.
- 9) Turn off the power.
- 10) Remove the jig P.C.B. and jig cables (2P).
- 11) Reconnect the disconnected cables as originally connected.

ID Check Procedure

Check the written ID.

- 1) Turn on the power.
- 2) While pressing the “□” key, press the “MODE” key.
- 3) Press the “MENU” key.
- 4) Turn the “MULTI JOG” knob to select “Sys Utility” and then press the “MULTI JOG” knob.
- 5) Turn the “MULTI JOG” knob to select “Sys ID Check” and then press the “MULTI JOG” knob.
- 6) “Serial number : Limit number” is displayed.
Note) The limit number means the remaining number of write enable times.
Check that the displayed serial number matches with the serial number displayed on the rear panel of the main unit.
- 7) Turn the “MULTI JOG” knob, and the model name is displayed. Check that the model name is correct.
- 8) Turn off the power.
- 9) Install the top cover.

操作手順

- 1) 電源を入れます。
「System Utility」に「Sys ID write」メニューおよび「Sys ID check」メニューが自動的に追加されます。
- 2) “MENU”キーを押します。
- 3) “MULTI JOG”つまみを回して、「Sys Utility」を選びます。
“MULTI JOG”つまみを押します。
- 4) “MULTI JOG”つまみを回して、「Sys ID Write」を選びます。
“MULTI JOG”つまみを押します。
- 5) “MULTI JOG”つまみを回して、モデル名に応じて「CDR-HD1500」を選びます。
“MULTI JOG”つまみを押します。
- 6) 「Y000000XZ」が表示されます。
本体のリアパネル、またはシャーシ内側に表示されているシリアルナンバーを入力します。
 - 6)-1 “MULTI JOG”つまみを右に回します。
右に回すと文字が表示されます。文字はアルファベット大文字、アルファベット小文字、数字、記号の順番に並んでいますので、適切なものを選択してください。
 - 6)-2 “MULTI JOG”つまみを押して、選択した文字を確定します。
カーソルが次の位置へ移動します。同様の操作を繰り返してタイトルをつけてください。

入力した文字を修正するには

“◀◀/◀◀”キーまたは“▶▶/▶▶”キー（リモコンでは“◀◀”キーまたは“▶▶”キー）を押してカーソルを修正したい文字の位置に移動し、“CLEAR”キーを押してその文字を消してから、新規に文字を入力し、確定してください。

- 7) “COMPLETE”キーを押します。
- 8) 「Complete」が表示されます。
これで書き込みは完了しました。
- 9) 電源を切ります。
- 10) 治具基板および治具ケーブル(2P)を取り外します。
- 11) 外したケーブルを元通りに接続します。

ID確認

書き込んだIDを確認します。

- 1) 電源を入れます。
- 2) “□”キーを押しながら“MODE”キーを押します。
- 3) “MENU”キーを押します。
- 4) “MULTI JOG”つまみを回して、「Sys Utility」を選びます。
“MULTI JOG”つまみを押します。
- 5) “MULTI JOG”つまみを回して、「Sys ID Check」を選びます。
“MULTI JOG”つまみを押します。
- 6) 「シリアルナンバー：リミットナンバー」が表示されます。
注) リミットナンバーは書き込み可能な残りの回数です。
表示されたシリアルナンバーが、本体リアパネルに表示されたシリアルナンバーと一致することを確認します。
- 7) “MULTI JOG”つまみを回すとモデル名が表示されます。
モデル名が正しいことを確認します。
- 8) 電源を切ります。
- 9) トップカバーを取り付けます。

■ DISPLAY DATA

● V400 : BJ992GN (V9468600)

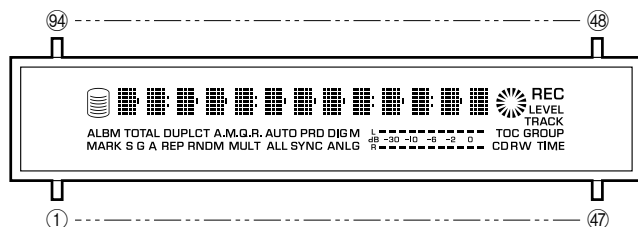

● PIN CONNECTION

Pin No.	94	93	92	91	90	89	88	87	86	85	84	83	82	81	80	79	78	77	76	75	74	73	72	71	70	69	68	67	66	65	64	63	62	61	60	59	58	57	56	55	54	53	52	51	50	49	48
Connection	F1	F1	NP	NP	P27	P28	P29	P30	P31	P32	P33	P34	P35	P36	16G	15G	14G	13G	NX	NX	NX	NX	NX	NX	NX	NX	NX	NX	NX	NX	12G	11G	10G	9G	8G	7G	6G	5G	4G	3G	2G	1G	IC	NP	NP	F2	F2

Pin No.	1	2	3	4	5	6	7	8	9	10	11	12	13	14	15	16	17	18	19	20	21	22	23	24	25	26	27	28	29	30	31	32	33	34	35	36	37	38	39	40	41	42	43	44	45	46	47
Connection	F1	F1	NP	NP	P26	P25	P24	P23	P22	P21	P20	P19	P18	P17	P16	P15	P14	NX	NX	NX	NX	NX	NX	NX	NX	NX	NX	NX	NX	P13	P12	P11	P10	P9	P8	P7	P6	P5	P4	P3	P2	P1	IC	NP	NP	F2	F2

Note : 1) F1, F2 Filament 2) NP No pin 3) NX No extend pin 4) DL Datum Line 5) 1G ~ 16G Grid 6) IC Internal connection

● GRID ASSIGNMENT

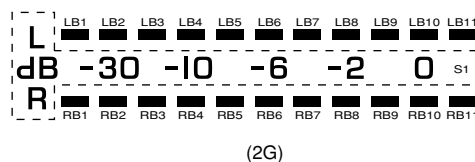
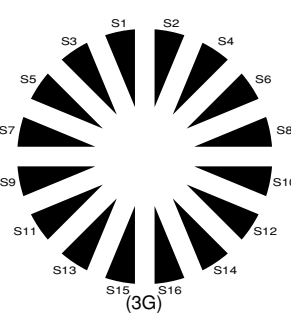
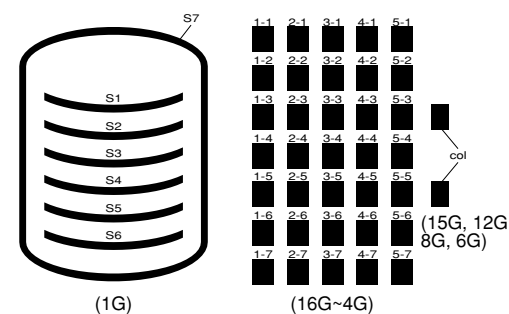
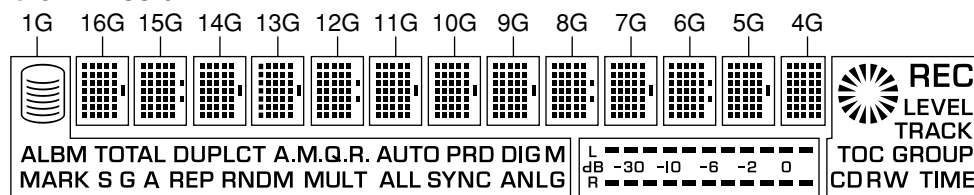

● ANODE CONNECTION

	1G	2G	3G	4G	5G	6G	7G	8G	9G	10G	11G	12G	13G	14G	15G	16G
P1	S7	RB1	S1	1-1	1-1	1-1	1-1	1-1	1-1	1-1	1-1	1-1	1-1	1-1	1-1	1-1
P2	S1	RB2	S2	2-1	2-1	2-1	2-1	2-1	2-1	2-1	2-1	2-1	2-1	2-1	2-1	2-1
P3	S2	RB3	S3	3-1	3-1	3-1	3-1	3-1	3-1	3-1	3-1	3-1	3-1	3-1	3-1	3-1
P4	S3	RB4	S4	4-1	4-1	4-1	4-1	4-1	4-1	4-1	4-1	4-1	4-1	4-1	4-1	4-1
P5	S4	RB5	S5	5-1	5-1	5-1	5-1	5-1	5-1	5-1	5-1	5-1	5-1	5-1	5-1	5-1
P6	S5	RB6	S6	1-2	1-2	1-2	1-2	1-2	1-2	1-2	1-2	1-2	1-2	1-2	1-2	1-2
P7	S6	RB7	S7	2-2	2-2	2-2	2-2	2-2	2-2	2-2	2-2	2-2	2-2	2-2	2-2	2-2
P8	—	RB8	S8	3-2	3-2	3-2	3-2	3-2	3-2	3-2	3-2	3-2	3-2	3-2	3-2	3-2
P9	—	RB9	S9	4-2	4-2	4-2	4-2	4-2	4-2	4-2	4-2	4-2	4-2	4-2	4-2	4-2
P10	—	RB10	S10	5-2	5-2	5-2	5-2	5-2	5-2	5-2	5-2	5-2	5-2	5-2	5-2	5-2
P11	—	RB11	S11	1-3	1-3	1-3	1-3	1-3	1-3	1-3	1-3	1-3	1-3	1-3	1-3	1-3
P12	—	S1	S12	2-3	2-3	2-3	2-3	2-3	2-3	2-3	2-3	2-3	2-3	2-3	2-3	2-3
P13	ANLG	LB1	S13	3-3	3-3	3-3	3-3	3-3	3-3	3-3	3-3	3-3	3-3	3-3	3-3	3-3
P14	M	LB2	S14	4-3	4-3	4-3	4-3	4-3	4-3	4-3	4-3	4-3	4-3	4-3	4-3	4-3
P15	DIG	LB3	S15	5-3	5-3	5-3	5-3	5-3	5-3	5-3	5-3	5-3	5-3	5-3	5-3	5-3
P16	SYNC	LB4	S16	1-4	1-4	1-4	1-4	1-4	1-4	1-4	1-4	1-4	1-4	1-4	1-4	1-4
P17	PRD	LB5	REC	2-4	2-4	2-4	2-4	2-4	2-4	2-4	2-4	2-4	2-4	2-4	2-4	2-4
P18	ALL	LB6	LEVEL	3-4	3-4	3-4	3-4	3-4	3-4	3-4	3-4	3-4	3-4	3-4	3-4	3-4
P19	AUTO	LB7	TRACK	4-4	4-4	4-4	4-4	4-4	4-4	4-4	4-4	4-4	4-4	4-4	4-4	4-4
P20	MULT	LB8	TOC	5-4	5-4	5-4	5-4	5-4	5-4	5-4	5-4	5-4	5-4	5-4	5-4	5-4
P21	A.M.Q.R.	LB9	GROUP	1-5	1-5	1-5	1-5	1-5	1-5	1-5	1-5	1-5	1-5	1-5	1-5	1-5
P22	RNDM	LB10	CD	2-5	2-5	2-5	2-5	2-5	2-5	2-5	2-5	2-5	2-5	2-5	2-5	2-5
P23	DUPLCT	LB11	R	3-5	3-5	3-5	3-5	3-5	3-5	3-5	3-5	3-5	3-5	3-5	3-5	3-5
P24	REP	—	W	4-5	4-5	4-5	4-5	4-5	4-5	4-5	4-5	4-5	4-5	4-5	4-5	4-5
P25	A	—	TIME	5-5	5-5	5-5	5-5	5-5	5-5	5-5	5-5	5-5	5-5	5-5	5-5	5-5
P26	TOTAL	—	—	1-6	1-6	1-6	1-6	1-6	1-6	1-6	1-6	1-6	1-6	1-6	1-6	1-6
P27	G	—	—	2-6	2-6	2-6	2-6	2-6	2-6	2-6	2-6	2-6	2-6	2-6	2-6	2-6
P28	S	—	—	3-6	3-6	3-6	3-6	3-6	3-6	3-6	3-6	3-6	3-6	3-6	3-6	3-6
P29	ALBM	—	—	4-6	4-6	4-6	4-6	4-6	4-6	4-6	4-6	4-6	4-6	4-6	4-6	4-6
P30	MARK	—	—	5-6	5-6	5-6	5-6	5-6	5-6	5-6	5-6	5-6	5-6	5-6	5-6	5-6
P31	—	—	—	1-7	1-7	1-7	1-7	1-7	1-7	1-7	1-7	1-7	1-7	1-7	1-7	1-7
P32	—	—	—	2-7	2-7	2-7	2-7	2-7	2-7	2-7	2-7	2-7	2-7	2-7	2-7	2-7
P33	—	—	—	3-7	3-7	3-7	3-7	3-7	3-7	3-7	3-7	3-7	3-7	3-7	3-7	3-7
P34	—	—	—	4-7	4-7	4-7	4-7	4-7	4-7	4-7	4-7	4-7	4-7	4-7	4-7	4-7
P35	—	—	—	5-7	5-7	5-7	5-7	5-7	5-7	5-7	5-7	5-7	5-7	5-7	5-7	5-7
P36	—	—	—	—	┃	col	┃	col	┃	┃	┃	col	┃	┃	col	┃

IC DATA

IC2 : HD6417014F28 (MAIN P.C.B.)

μ-COM (CPU)

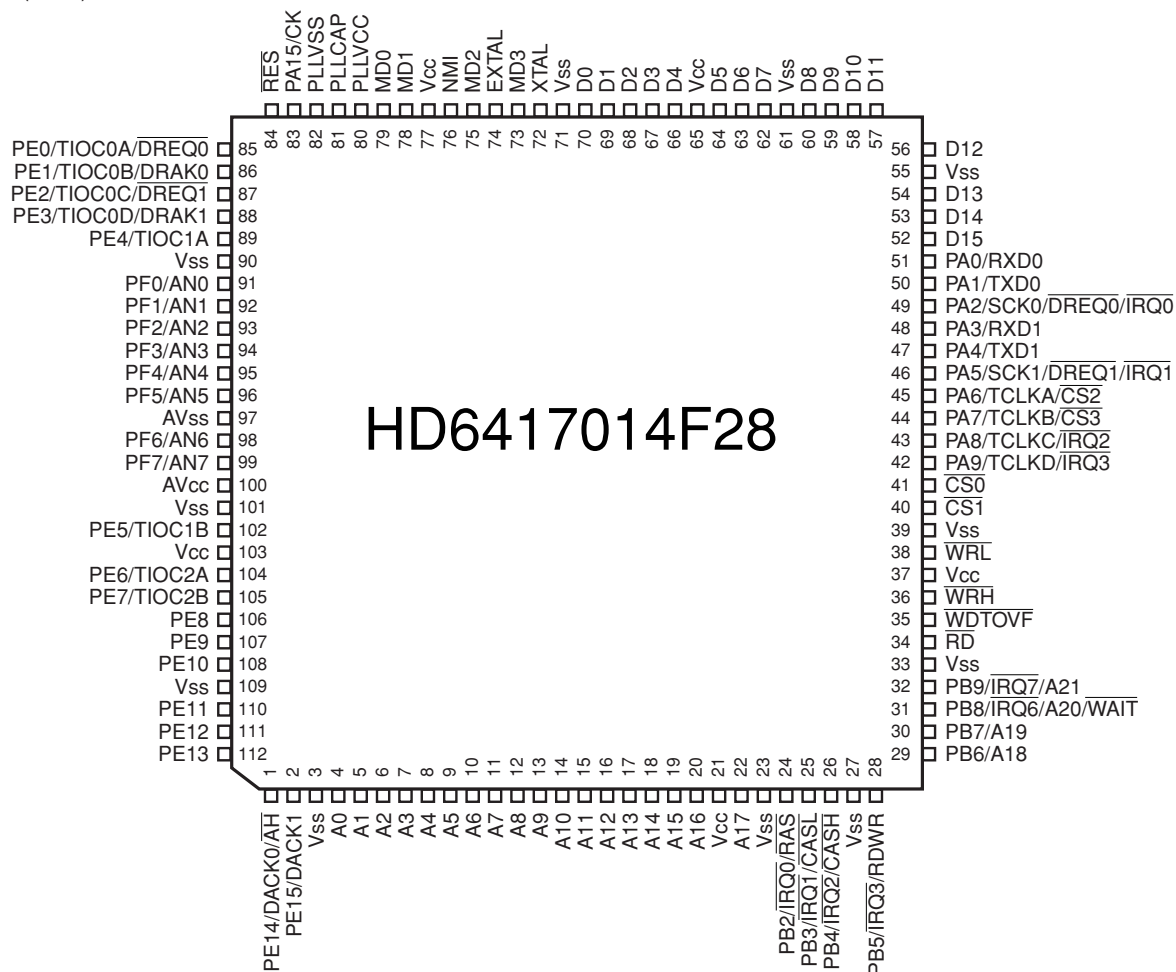

No.	Port	Name	I/O	Function
1	PE14	DIP2	IN	for extend
2	PE15	LED3	OUT	Fan control
3	VSS			GND
4	A0		O	Address bus
5	A1		O	Address bus
6	A2		O	Address bus
7	A3		O	Address bus
8	A4		O	Address bus
9	A5		O	Address bus
10	A6		O	Address bus
11	A7		O	Address bus
12	A8		O	Address bus
13	A9		O	Address bus
14	A10		O	Address bus
15	A11		O	Address bus
16	A12		O	Address bus
17	A13		O	Address bus
18	A14		O	Address bus
19	A15		O	Address bus
20	A16		O	Address bus

IC2 : HD6417014F28 (MAIN P.C.B.)

μ-COM (CPU)

No.	Port	Name	I/O	Function
21	Vcc			+5V power supply
22	A17		O	Address bus
23	Vss			GND
24	/RAS	N_RAS	O	DRAM control
25	/CASL	N_CASL	O	DRAM control
26	/CASH	N_CASH	O	DRAM control
27	Vss			GND
28	RDWR	RDWR	O	DRAM control
29	A18		O	Address bus
30	A19		O	Address bus
31	/WAIT	N_WAIT	I	WAIT input
32	PB9	CPU_MUTE	O	Output mute
33	Vss			GND
34	/RD	N_RD	O	Read strobe
35	/WDTOVF			(Unconnected)
36	/WRH	N_WRH	O	Write strobe
37	Vcc			+5V power supply
38	/WRL	N_WRL	O	Write strobe
39	Vss			GND
40	/CS1	N_CDR	O	ACDR2 chip select
41	/CS0	N_ROM	O	Flash memory chip select
42	PA9	N_CPU_RST	O	Resetting peripheral devices
43	/IRQ2	N_IRQ2		for extend
44	/CS3	N_CS3		for extend
45	PA6	SB_N_OSD		OSD IC chip select
46	/IRQ1	N_INT_CDR	I	ACDR2 interrupt
47	TXD1	TXD1	O	RS-232C output
48	RXD1	RXD1	I	RS-232C input
49	/IRQ0	N_INT_REM	I	Remote control input
50	TXD0	TXD0		for extend
51	RXD0	RXD0		for extend
52	D15		I/O	Data bus
53	D14		I/O	Data bus
54	D13		I/O	Data bus
55	Vss			GND
56	D12		I/O	Data bus
57	D11		I/O	Data Bus
58	D10		I/O	Data Bus
59	D9		I/O	Data Bus
60	D8		I/O	Data Bus
61	Vss			GND
62	D7		I/O	Data Bus
63	D6		I/O	Data Bus
64	D5		I/O	Data Bus
65	Vcc			+5V Power Supply
66	D4		I/O	Data Bus
67	D3		I/O	Data Bus
68	D2		I/O	Data Bus
69	D1		I/O	Data Bus
70	D0		I/O	Data Bus
71	Vss			GND
72	XTAL		O	Terminal for crystal oscillator
73	MD3		I	Setting CPU operation mode
74	EXTAL		I	Terminal for crystal oscillator
75	MD2		I	Setting CPU operation mode

IC2 : HD6417014F28 (MAIN P.C.B.)

μ-COM (CPU)

No.	Port	Name	I/O	Function
76	NMI		I	NMI input
77	Vcc			+5V Power Supply
78	MD1		I	Setting CPU operation mode
79	MD0		I	Setting CPU operation mode
80	PLLVCC			+5V Power Supply
81	PLLCAP		O	PLL Capacitor Terminal
82	PLLVSS			GND
83	CK		O	Peripheral device clock
84	/RES		I	Reset input
85	TIOC0A	LED_HD_B	O	Panel LED control
86	TIOC0B	LED_HD_A	O	Panel LED control
87	TIOC0C	LED_CD_B	O	Panel LED control
88	TIOC0D	LED_CD_A	O	Panel LED control
89	PE4	SB_N_FL	O	FL control IC chip select
90	Vss			GND
91	AN0	PUI_KEY0	I	Panel key input
92	AN1	PUI_KEY1	I	Panel key input
93	AN2	PUI_KEY2	I	Panel key input
94	AN3	PUI_KEY3	I	Panel key input
95	AN4	PUI_KEY4	I	Panel key input
96	AN5	PUI_KEY5	I	A/D input for Thermistor
97	AVSS			GND for A/D
98	AN6	PUI_KEY6	I	Panel key input
99	AN7	PUI_KEY7	I	Panel key input
100	AVCC			+5V power supply for A/D
101	Vss			GND
102	PE5	SB_SCK	O	SB serial clock
103	Vcc			+5V power supply
104	PE6	OSD_BIT0	I	for extend
105	PE7	FLASH_N_VPP		for extend
106	PE8	SB_DATA	O	SB IC serial data
107	PE9	DIP0		for extend
108	PE10	DIP1		for extend
109	VSS			GND
110	PE11	LED0		for extend
111	PE12	LED1	O	RS-232C output
112	PE13	LED2	I	RS-232C input

Key Input (A-D) Pull-Up Resistance 10 k-Ohms

Ohm	+2.2 k	+4.7 k	+8.2 k	+22.0 k
V	~1.5	~2.5	~3.5	~4.5
PUI_KEY0 91pin/AN0	INPUT	ERASE	FINALIZE	REC
PUI_KEY1 92pin/AN1	FF/SKIP+	COMPLETE	PLAY/PHOUSE	STOP
PUI_KEY2 93pin/AN2	TEXT/TIME	TRACK NO./ BOOKMARK	REW/SKIP-	OPEN/CLOSE
PUI_KEY3 94pin/AN3	COPY	CDR	HDD	A.M.Q.R.
PUI_KEY4 95pin/AN4	CLEAR	MENU	ENTER (MULTI JOG)	MODE

IC3 : YDC126-F (MAIN P.C.B.)
ACDR

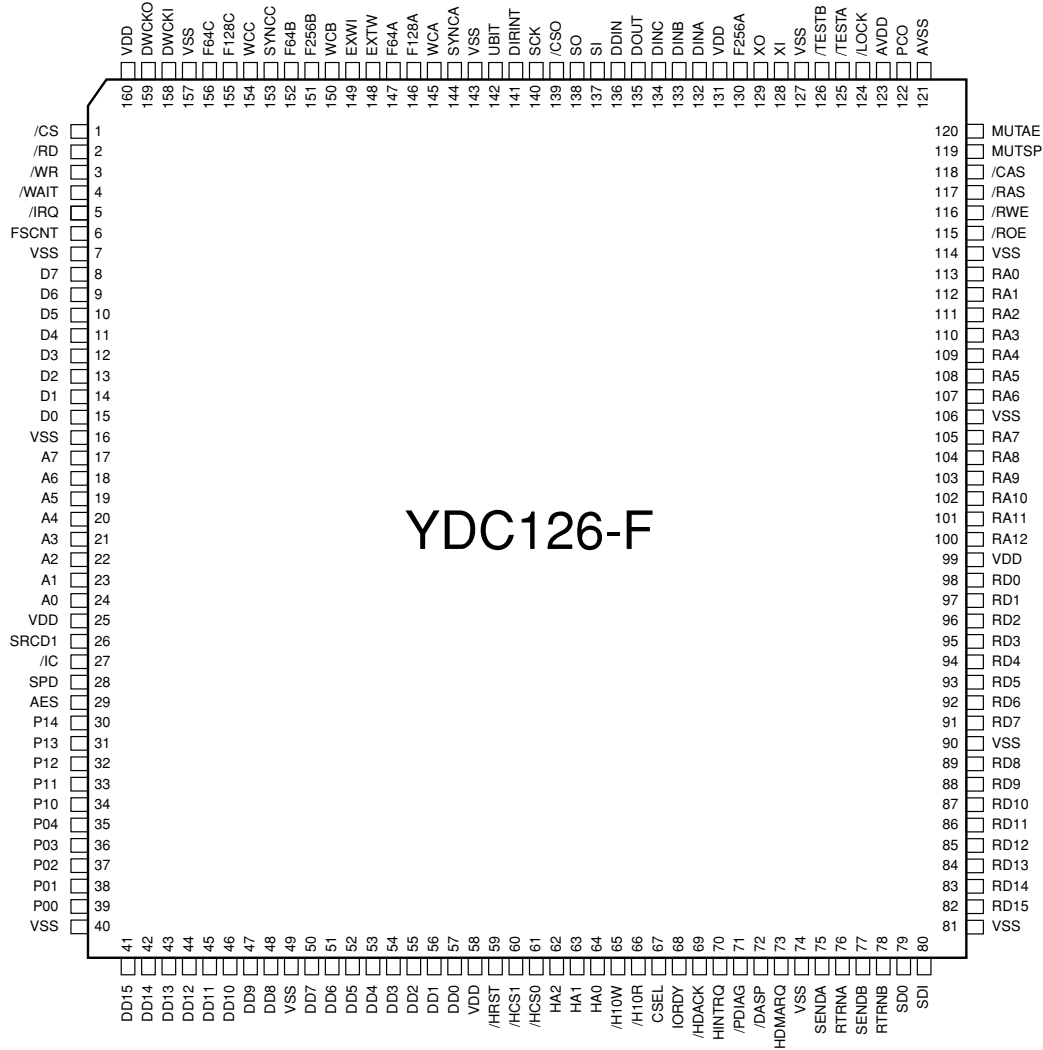

No.	Name	I/O	DC Level	Function
1	/CS	I	T	Microprocessor interface, chip select input
2	/RD	I	T	Microprocessor interface, read strobe input
3	/WR	I	T	Microprocessor interface, write strobe input
4	/WAIT	OD	C	Wait output
5	/IRQ	O	C	Interrupt request output
6	FSCNT	O\$	C	Dividing word clock output (Unconnected)
7	VSS			GND
8	D7	I/O	T/C	Microprocessor interface, data bus
9	D6	I/O	T/C	Microprocessor interface, data bus
10	D5	I/O	T/C	Microprocessor interface, data bus
11	D4	I/O	T/C	Microprocessor interface, data bus
12	D3	I/O	T/C	Microprocessor interface, data bus
13	D2	I/O	T/C	Microprocessor interface, data bus
14	D1	I/O	T/C	Microprocessor interface, data bus
15	D0	I/O	T/C	Microprocessor interface, data bus
16	VSS			GND
17	A7	I	T	Microprocessor interface, data bus
18	A6	I	T	Microprocessor interface, data bus
19	A5	I	T	Microprocessor interface, data bus
20	A4	I	T	Microprocessor interface, data bus
21	A3	I	T	Microprocessor interface, data bus
22	A2	I	T	Microprocessor interface, data bus
23	A1	I	T	Microprocessor interface, data bus
24	A0	I	T	Microprocessor interface, data bus
25	VDD			Power supply +5V
26	SRCDI	I+	T	(Unconnected)
27	/IC	I	T	Initial clear input
28	SPD	O	C	Digital audio interface output (SPDIF)

IC3 : YDC126-F (MAIN P.C.B.)

ACDR

No.	Name	I/O	DC Level	Function
29	AES	O	C	(Unconnected)
30	P14	I+	T	General purpose input port
31	P13	I+	T	General purpose input port
32	P12	I+	T	General purpose input port
33	P11	I+	T	General purpose input port
34	P10	I+	T	General purpose input port
35	P04	O	C	General purpose input port (Unconnected)
36	P03	O	C	General purpose input port
37	P02	O	C	General purpose input port
38	P01	O	C	General purpose input port
39	P00	O	C	General purpose input port
40	VSS			GND
41	DD15	I/O	T/C	IDE bus interface, data bus
42	DD14	I/O	T/C	IDE bus interface, data bus
43	DD13	I/O	T/C	IDE bus interface, data bus
44	DD12	I/O	T/C	IDE bus interface, data bus
45	DD11	I/O	T/C	IDE bus interface, data bus
46	DD10	I/O	T/C	IDE bus interface, data bus
47	DD9	I/O	T/C	IDE bus interface, data bus
48	DD8	I/O	T/C	IDE bus interface, data bus
49	VSS			GND
50	DD7	I/O	T/C	IDE bus interface, data bus
51	DD6	I/O	T/C	IDE bus interface, data bus
52	DD5	I/O	T/C	IDE bus interface, data bus
53	DD4	I/O	T/C	IDE bus interface, data bus
54	DD3	I/O	T/C	IDE bus interface, data bus
55	DD2	I/O	T/C	IDE bus interface, data bus
56	DD1	I/O	T/C	IDE bus interface, data bus
57	DD0	I/O	T/C	IDE bus interface, data bus
58	VDD			Power supply +5V
59	/HRST	OT	C	IDE bus interface, reset output
60	/HCS1	OT	C	IDE bus interface, chip select output
61	/HCS0	OT	C	IDE bus interface, chip select output
62	HA2	OT	C	IDE bus interface, address output
63	HA1	OT	C	IDE bus interface, address output
64	HA0	OT	C	IDE bus interface, address output
65	/H10W	OT	C	IDE bus interface, write strobe output
66	/H10R	OT	C	IDE bus interface, read strobe output
67	CSEL	OT	C	IDE bus interface, cable select output
68	IORDY	I	T	IDE bus interface, channel ready input
69	/HDACK	OT	C	IDE bus interface, DMA acknowledge output
70	HINTRQ	I	T	IDE bus interface, interrupt request input
71	/PDIAG	OD	C	IDE bus interface, connection diagnosis output
72	/DASP	OD	C	IDE bus interface, active slave output
73	HDMARQ	I	T	IDE bus interface, DMA request input
74	VSS			GND
75	SENDA	O	C	DSP3 serial data interface output 1
76	RTRNA	I+	T	DSP3 serial data interface input 1
77	SENDB	O	C	DSP3 serial data interface output 2
78	RTRNB	I+	T	DSP3 serial data interface input 2
79	SDO	O	C	Serial audio data output
80	SDI	I	T	Serial audio data input
81	VSS			GND
82	RD15	I/O	T/C	External RAM interface, data bus
83	RD14	I/O	T/C	External RAM interface, data bus
84	RD13	I/O	T/C	External RAM interface, data bus
85	RD12	I/O	T/C	External RAM interface, data bus
86	RD11	I/O	T/C	External RAM interface, data bus
87	RD10	I/O	T/C	External RAM interface, data bus
88	RD9	I/O	T/C	External RAM interface, data bus
89	RD8	I/O	T/C	External RAM interface, data bus
90	VSS			GND
91	RD7	I/O	T/C	External RAM interface, data bus
92	RD6	I/O	T/C	External RAM interface, data bus
93	RD5	I/O	T/C	External RAM interface, data bus
94	RD4	I/O	T/C	External RAM interface, data bus
95	RD3	I/O	T/C	External RAM interface, data bus
96	RD2	I/O	T/C	External RAM interface, data bus

IC3 : YDC126-F (MAIN P.C.B.)

ACDR

No.	Name	I/O	DC Level	Function
97	RD1	I/O	T/C	External RAM interface, data bus
98	RD0	I/O	T/C	External RAM interface, data bus
99	VDD			Power supply +5V
100	RA12	O	C	External RAM interface, address output (Unconnected)
101	RA11	O	C	External RAM interface, address output (Unconnected)
102	RA10	O	C	External RAM interface, address output (Unconnected)
103	RA9	O	C	External RAM interface, address output (Unconnected)
104	RA8	O	C	External RAM interface, address output
105	RA7	O	C	External RAM interface, address output
106	VSS			GND
107	RA6	O	C	External RAM interface, address output
108	RA5	O	C	External RAM interface, address output
109	RA4	O	C	External RAM interface, address output
110	RA3	O	C	External RAM interface, address output
111	RA2	O	C	External RAM interface, address output
112	RA1	O	C	External RAM interface, address output
113	RA0	O	C	External RAM interface, address output
114	VSS			GND
115	/ROE	O	C	External RAM interface, read strobe output
116	/RWE	O	C	External RAM interface, write strobe output
117	/RAS	O	C	External RAM interface, lower address strobe output
118	/CAS	O	C	External RAM interface column address strobe output
119	MUTSP	I	T	SPD pin mute control input, muting provided at "1"
120	MUTAE	I+	T	Unconnected
121	AVSS			Analog GND for PLL
122	PCO	A		Capacitance connection terminal for PLL
123	AVDD			Analog power supply for PLL +5V
124	/LOCK	O	C	Master clock, PLL lock detect output
125	/TESTA	I+	T	testing terminal (Unconnected)
126	/TESTB	I+	T	testing terminal (Unconnected)
127	VSS			GND
128	XI	I\$	C	24.576MHz crystal oscillator connection terminal (input)
129	XO	O\$	C	24.576MHz crystal oscillator connection terminal (output)
130	F256A	O\$	C	Master clock, dividing clock output (256fs)
131	VDD			Power supply +5V
132	DINA	I+	T	Digital audio interface input A
133	DINB	I+	T	Digital audio interface input B
134	DINC	I+	T	Digital audio interface input C (Unconnected)
135	DOUT	O	C	Digital audio interface output
136	DDIN	I	T	Serial audio data input
137	SI	I+	T	DIR5 interface, control data input
138	SO	O	C	DIR5 interface, control data output
139	/CSO	O	C	DIR5 interface, chip select output
140	SCK	O\$	C	DIR5 interface, bit clock output
141	DIRINT	I+	T	DIR5 interface, interrupt input
142	UBIT	I+	T	DIR5 interface, U-bit signal input
143	VSS			GND
144	SYNCA	O	C	Master clock system, synchronous signal output
145	WCA	O\$	C	Master clock system, word clock output (fs)
146	F128A	O\$	C	Master clock system, dividing clock output (128fs)
147	F64A	O\$	C	Master clock system, dividing clock output (64fs)
148	EXTW	O\$	C	Word clock output (fs)
149	EXWI	I\$+	T	External word clock input (fs) (Unconnected)
150	WCB	I\$	T	Digital input data system, word clock input (fs)
151	F256B	I\$	T	Digital input data system, dividing clock input (256fs)
152	F64B	I\$	T	Digital input data system, dividing clock input (64fs)
153	SYNCC	I+	T	(Unconnected)
154	WCC	I\$+	T	Mode switching, "1": normal operation, "0": PLL constant output mode
155	F128C	I\$+	T	(Unconnected)
156	F64C	I\$+	T	(Unconnected)
157	VSS			GND
158	DWCKI	I\$	T	Drive word clock input (44.1kHz or 33.8688MHz)
159	DWCKO	O\$	C	Drive word clock output (for charge couple)
160	VDD			Power supply +5V

I/O I: Input O: Output I/O: Bi-directional \$: Clock signal OT: Tri-state output
 +: Pull-up resistor built-in A: Analog terminal OD: Open drain

DC C: CMOS level T: TTL level

IC401 : M66005-0141AFP (OPERATION P.C.B.)
 FL tube driver

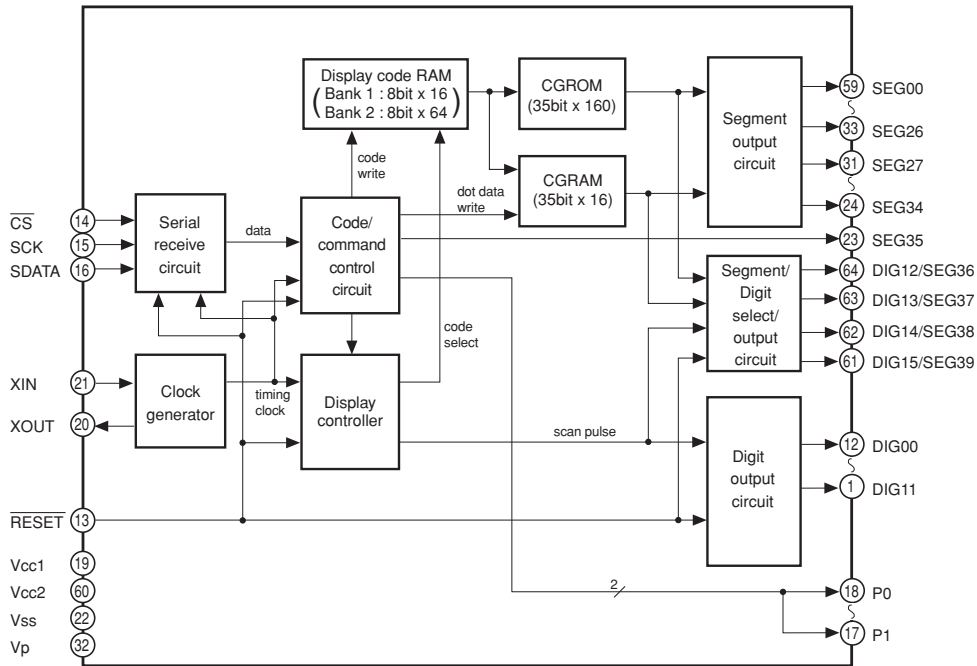
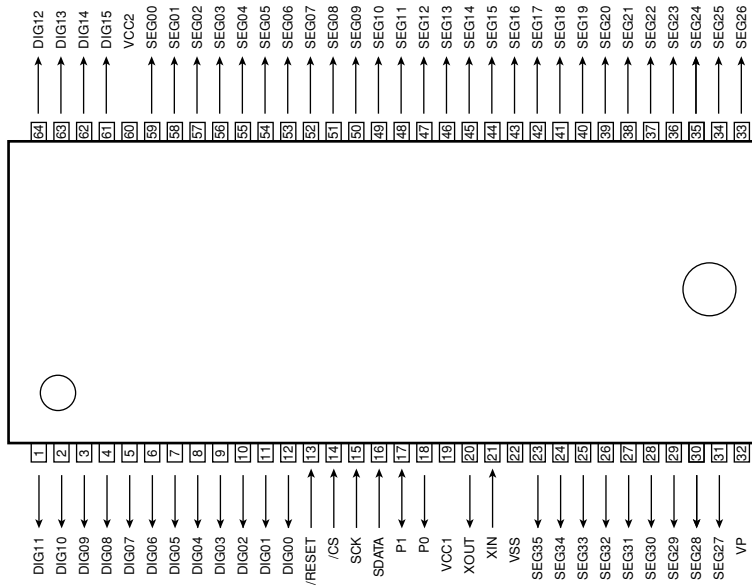

No.	Name	IN/OUT	Function
1	DIG11	O	Digit output
2	DIG10	O	Digit output
3	DIG09	O	Digit output
4	DIG08	O	Digit output
5	DIG07	O	Digit output
6	DIG06	O	Digit output
7	DIG05	O	Digit output
8	DIG04	O	Digit output
9	DIG03	O	Digit output
10	DIG02	O	Digit output

IC401 : M66005-0141AFP (OPERATION P.C.B.)

FL tube driver

No.	Name	IN/OUT	Function
11	DIG01	O	Digit output
12	DIG00	O	Digit output
13	/RESET	I	Reset input
14	/CS	I	Chip select input
15	SCK	I	Shift clock input
16	SDATA	I	Serial data input
17	P1	I/O	Universal port
18	P0	O	Universal port
19	VCC1		Positive power supply for internal logic
20	XOUT	O	Clock output
21	XIN	I	Clock input
22	VSS		GND (0V)
23	SEG35	O	Segment output
24	SEG34	O	Segment output
25	SEG33	O	Segment output
26	SEG32	O	Segment output
27	SEG31	O	Segment output
28	SEG30	O	Segment output
29	SEG29	O	Segment output
30	SEG28	O	Segment output
31	SEG27	O	Segment output
32	VP		Negative power supply to pull down
33	SEG26	O	Segment output
34	SEG25	O	Segment output
35	SEG24	O	Segment output
36	SEG23	O	Segment output
37	SEG22	O	Segment output
38	SEG21	O	Segment output
39	SEG20	O	Segment output
40	SEG19	O	Segment output
41	SEG18	O	Segment output
42	SEG17	O	Segment output
43	SEG16	O	Segment output
44	SEG15	O	Segment output
45	SEG14	O	Segment output
46	SEG13	O	Segment output
47	SEG12	O	Segment output
48	SEG11	O	Segment output
49	SEG10	O	Segment output
50	SEG09	O	Segment output
51	SEG08	O	Segment output
52	SEG07	O	Segment output
53	SEG06	O	Segment output
54	SEG05	O	Segment output
55	SEG04	O	Segment output
56	SEG03	O	Segment output
57	SEG02	O	Segment output
58	SEG01	O	Segment output
59	SEG00	O	Segment output
60	VCC2		Positive power supply for DIG and SEG outputs
61	DIG15	O	Digit output
62	DIG14	O	Digit output
63	DIG13	O	Digit output
64	DIG12	O	Digit output

BLOCK DIAGRAM

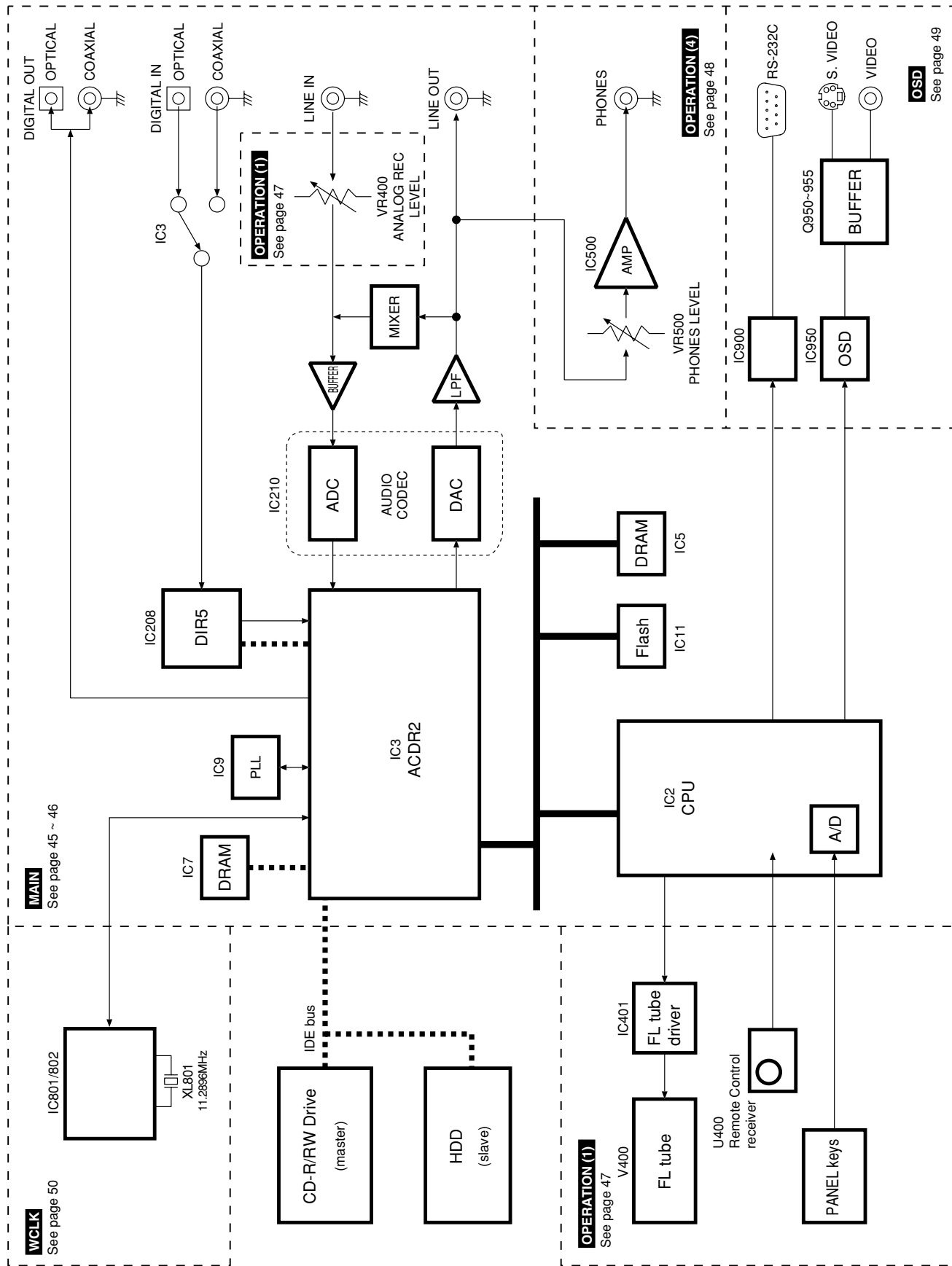

SCHEMATIC DIAGRAM (MAIN 1/2)

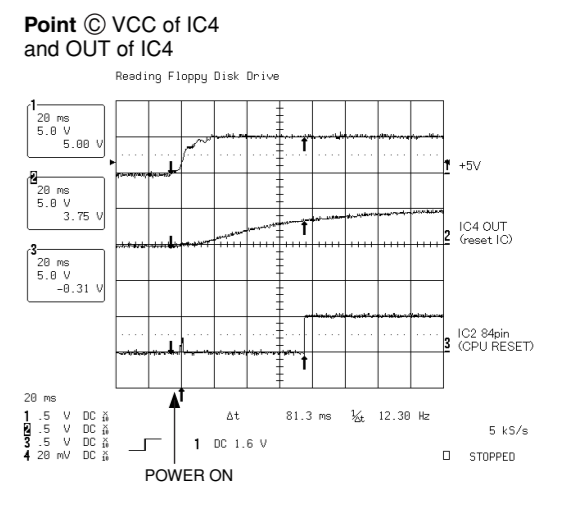
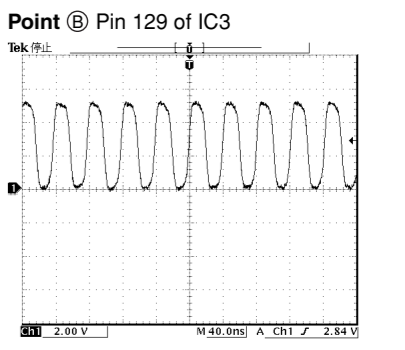
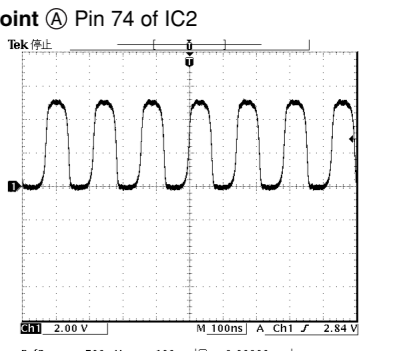
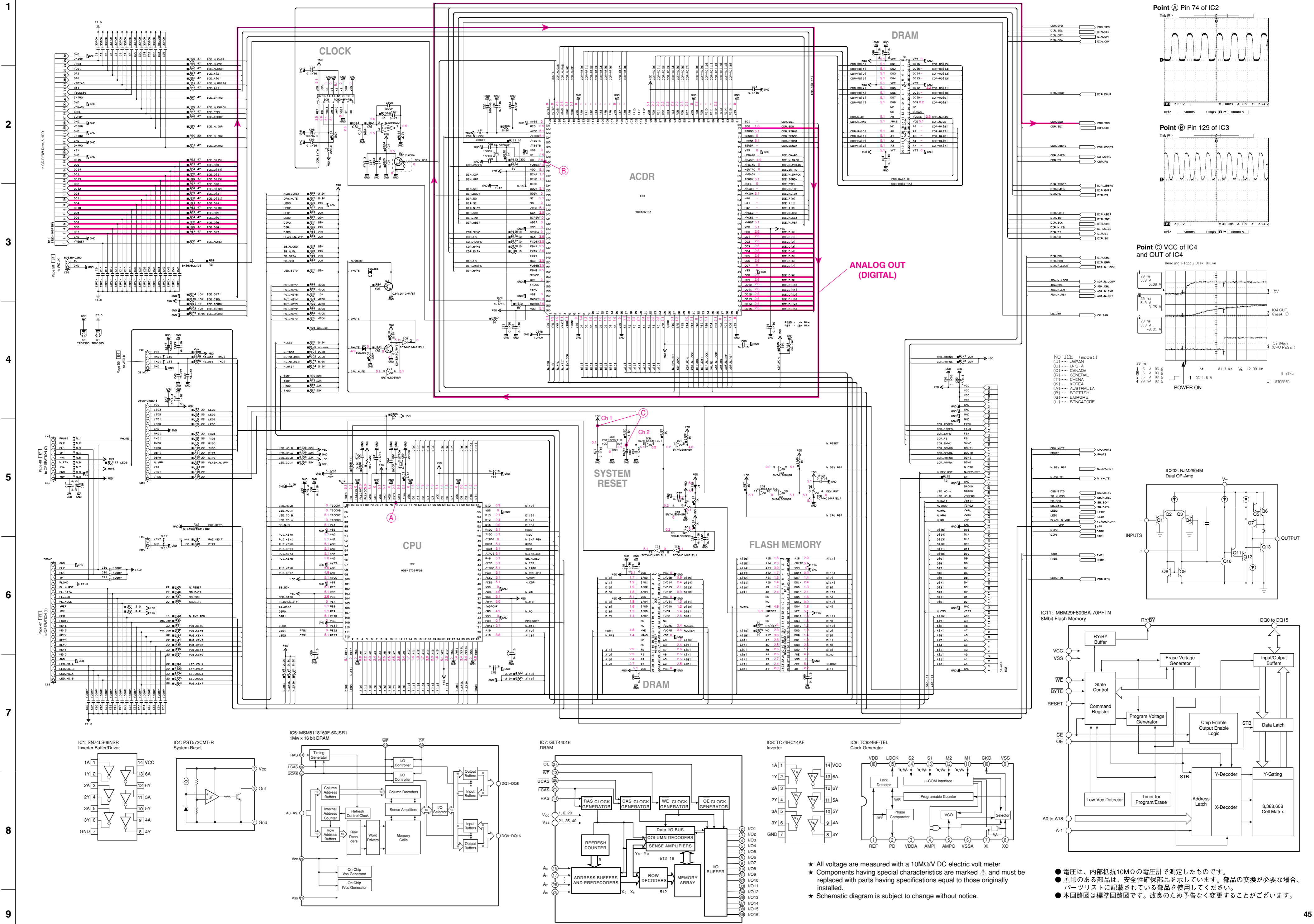

NOTICE (mode1)
 (J)..... JAPAN
 (U)..... U.S.A.
 (C)..... CANADA
 (G)..... GENERAL
 (T)..... CHINA
 (K)..... KOREA
 (A)..... AUSTRALIA
 (B)..... BRITISH
 (S)..... EUROPE
 (L)..... SINGAPORE

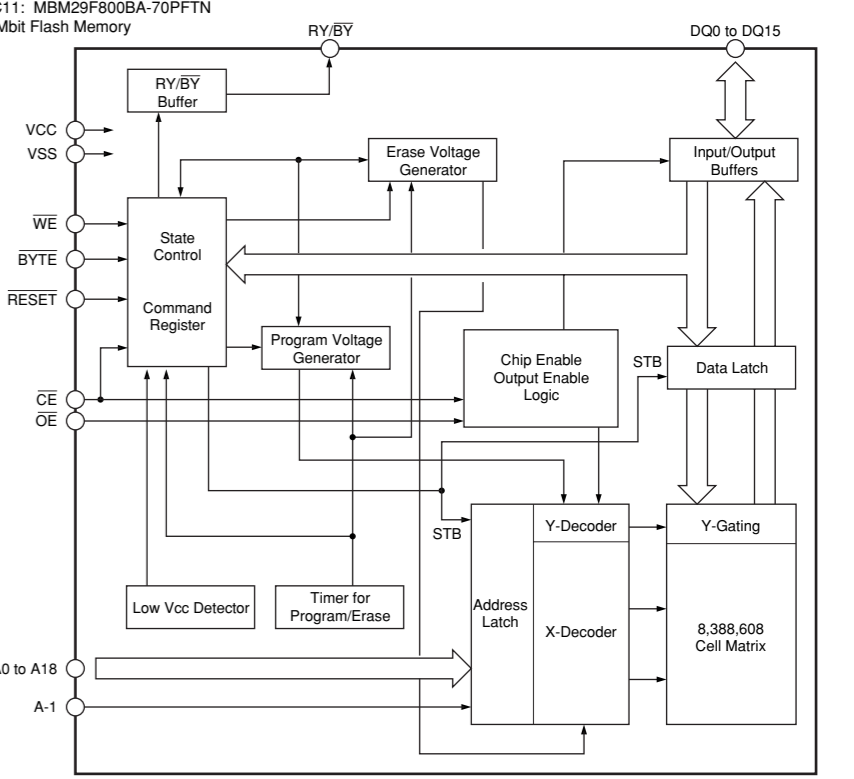
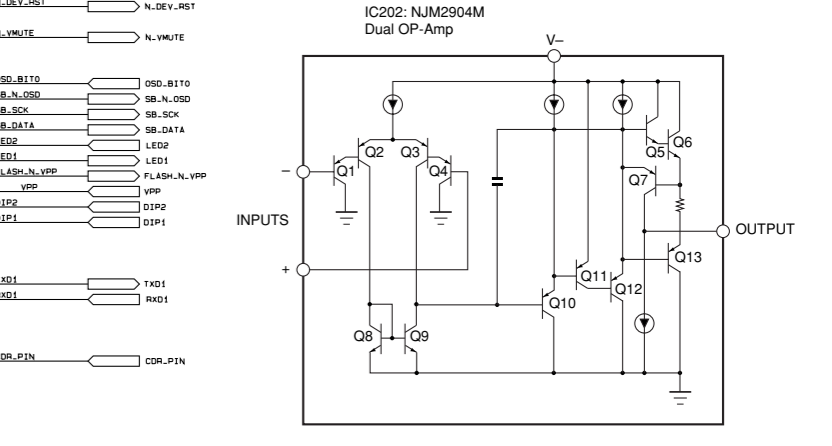

- All voltage are measured with a 10MΩ/V dc electric voltmeter.
- Components having special characteristics are marked (▲), and must be replaced with parts having specifications equal to those originally installed.
- Schematic diagram is subject to change without notice.
- 電圧は、内部抵抗10MΩの電圧計で測定したものです。
- ▲印のある部品は、安全性確保部品を示しています。部品の交換が必要な場合、パーツリストに記載されている部品を使用してください。
- 本回路図は標準回路図です。改良のため予告なく変更することがございます。

SCHEMATIC DIAGRAM (MAIN 2/2)

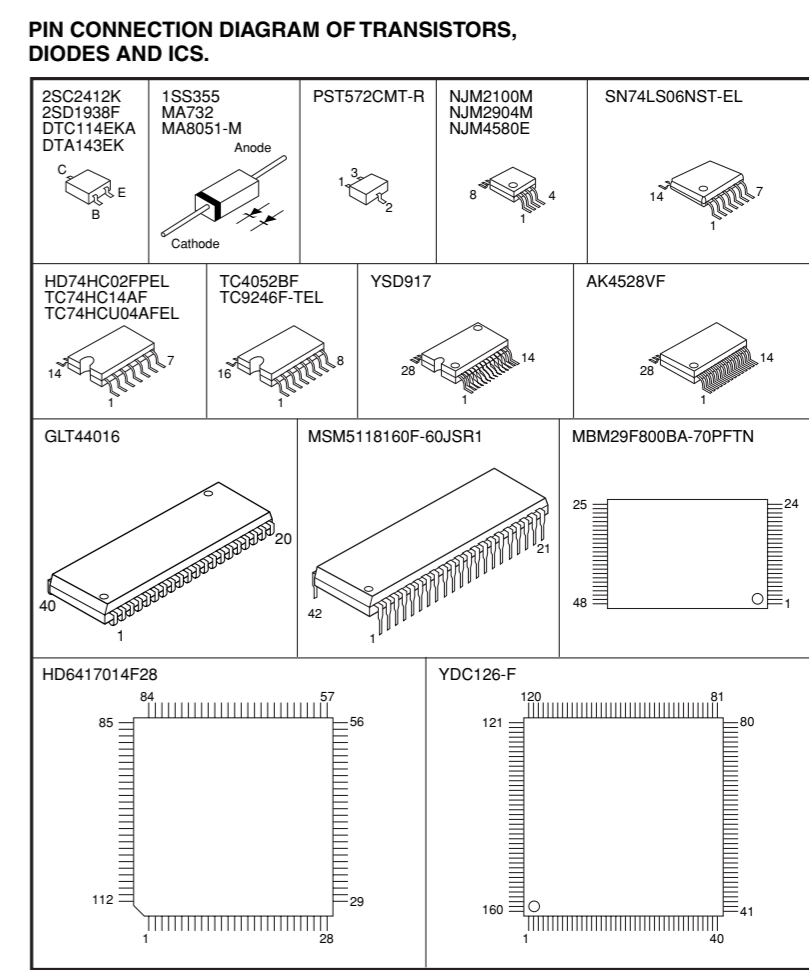
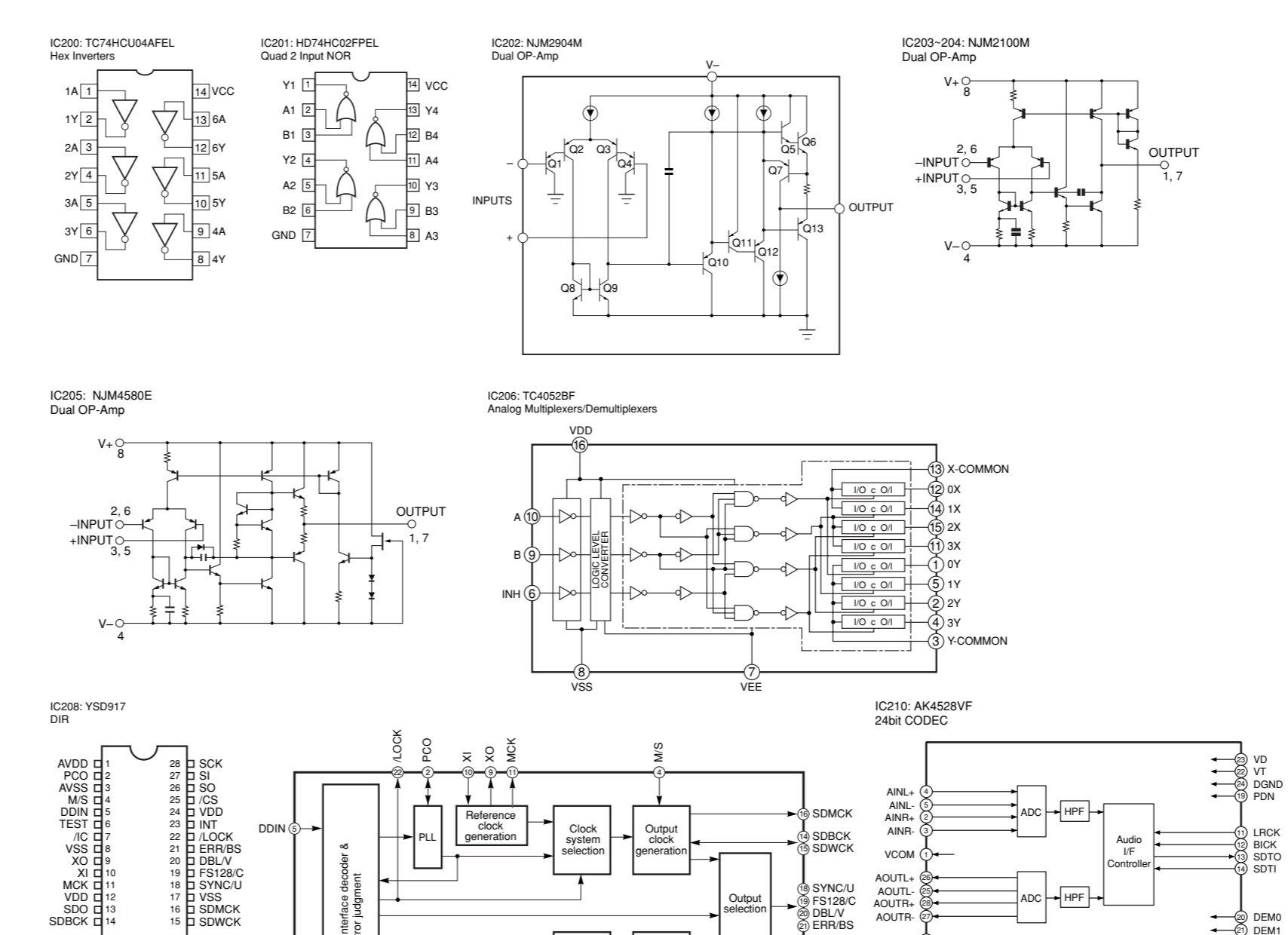
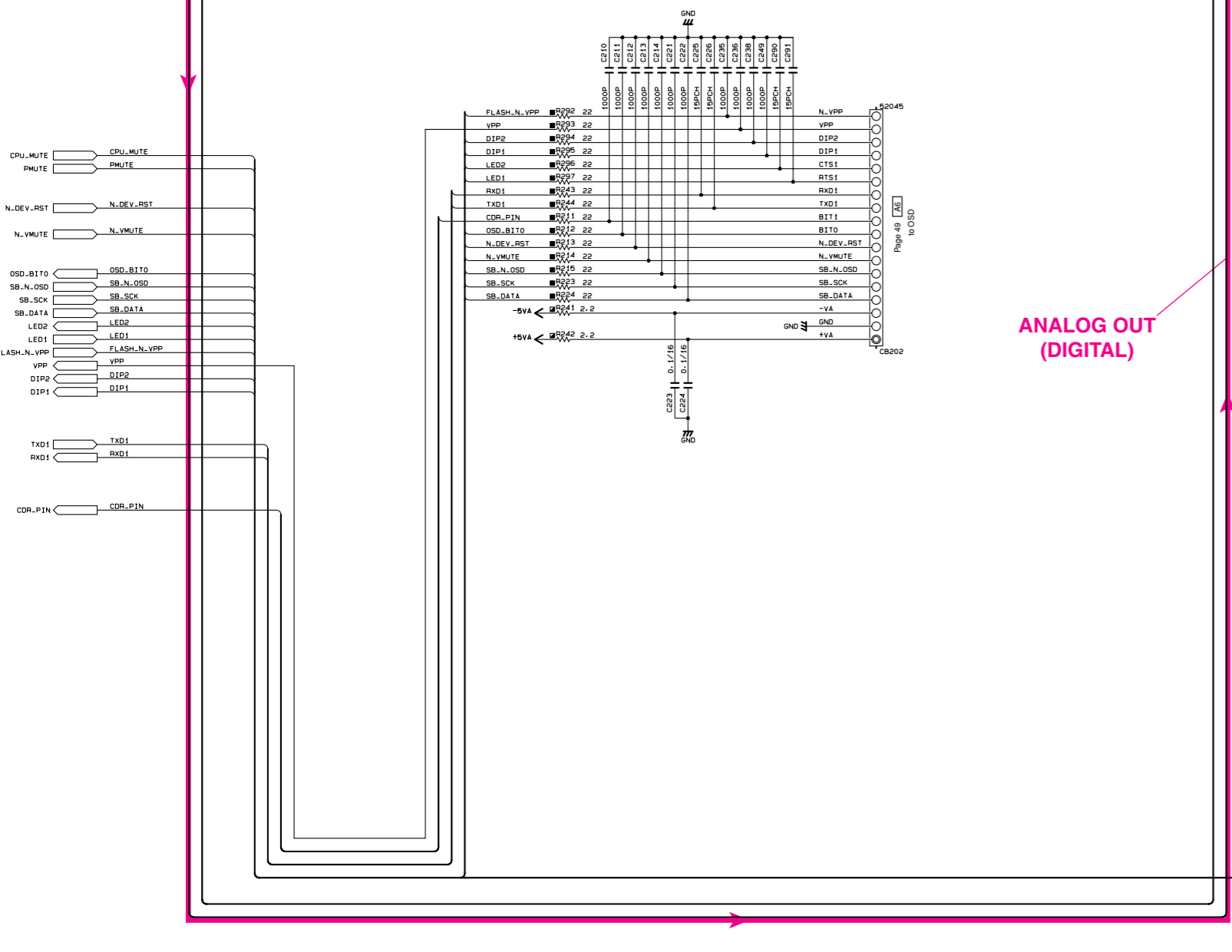
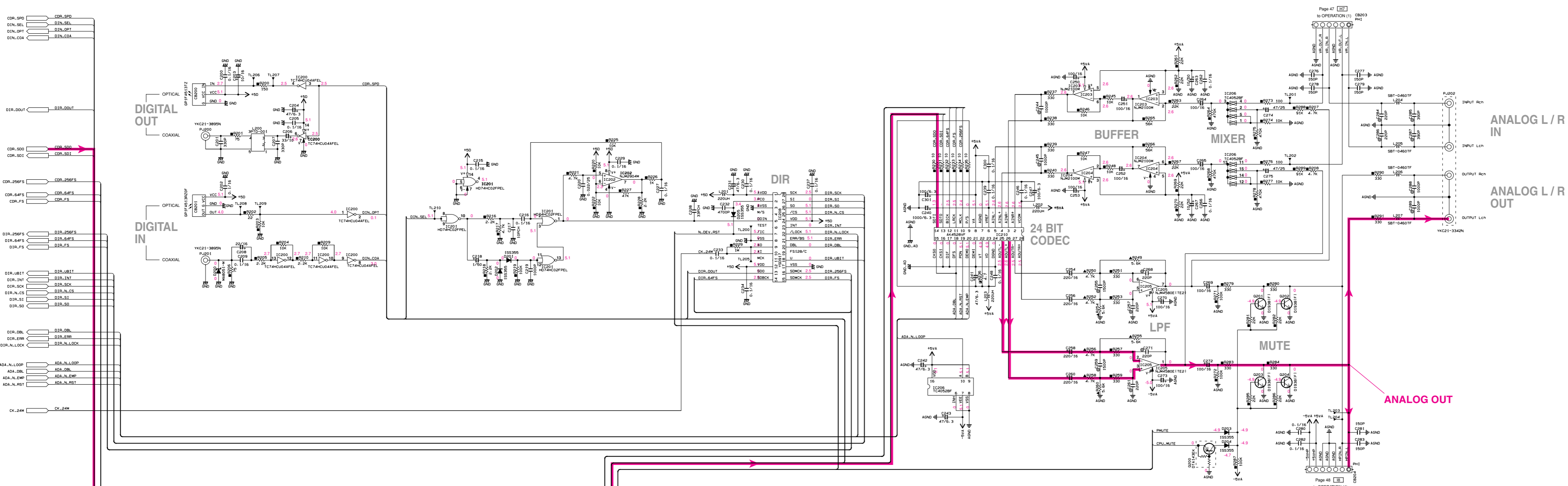

RESISTOR	PARTS NAME	CAPACITOR	PARTS NAME
NO MARK	CARBON FILM RESISTOR (P=5)	NO MARK	ELECTROLYTIC CAPACITOR
△	CARBON FILM RESISTOR (P=10)	⊗	TANTALUM CAPACITOR
□	METAL OXIDE FILM RESISTOR	□	CERAMIC TUBULAR CAPACITOR
▲	METAL FILM RESISTOR	○	POLYSTYRENE FILM CAPACITOR
■	METAL PLATE RESISTOR	○	MICA CAPACITOR
■	FIRE PROOF CARBON FILM RESISTOR	○	POLYPROPYLENE FILM CAPACITOR
□	CEMENT MOLDED RESISTOR	○	SEMICONDUCTIVE CERAMIC CAPACITOR
□	SEMI VARIABLE RESISTOR	○	POLYPHENYLENE SULFIDE FILM CAPACITOR
■	CHIP RESISTOR		

Interchangeable Parts at Manufacture Stage			
Mark	Reference Parts Number	Parts Name	
61	IC7	DL44016-40J4	
		M18416296-25-P	

NOTICE (mode1)
 (J)..... JAPAN
 (U)..... U.S.A.
 (C)..... CANADA
 (G)..... GENERAL
 (T)..... CHINA
 (K)..... KOREA
 (A)..... AUSTRALIA
 (B)..... BRITISH
 (E)..... EUROPE
 (S)..... SINGAPORE

★ All voltage are measured with a 10MΩ/V DC electric volt meter.
 ★ Components having special characteristics are marked !, and must be replaced with parts having specifications equal to those originally installed.
 ★ Schematic diagram is subject to change without notice.
 ● 電圧は、内部抵抗10MΩの電圧計で測定したものです。
 ● !印のある部品は、安全性確保部品を示しています。部品の交換が必要な場合、パーツリストに記載されている部品を使用してください。
 ● 本回路図は標準回路図です。改良のため予告なく変更することがございます。

SCHEMATIC DIAGRAM (OPERATION 1/2)

Interchangeable Parts at Manufacture-Stage

Mark	Reference Parts Number	Parts Name
k1	0700.703	25A933S(G/R) 25A1115(E/F) 25A1309A(G/R/S)
k2	0407	25C287B(A/B) 25D1915F(S/T)
k3	0403-406.408.409 450.751	DTC114ES UN4211

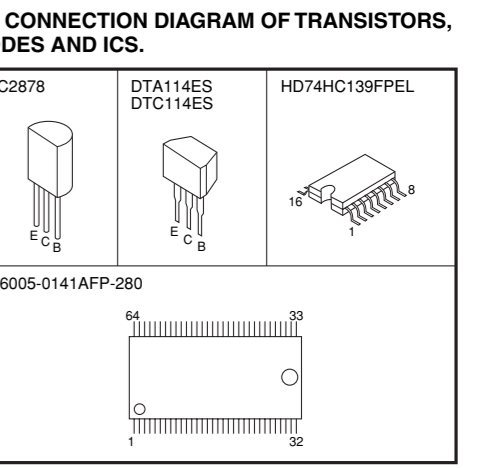
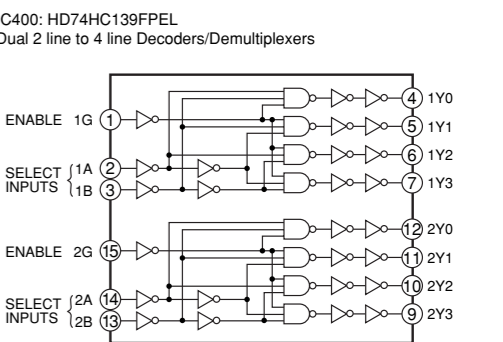
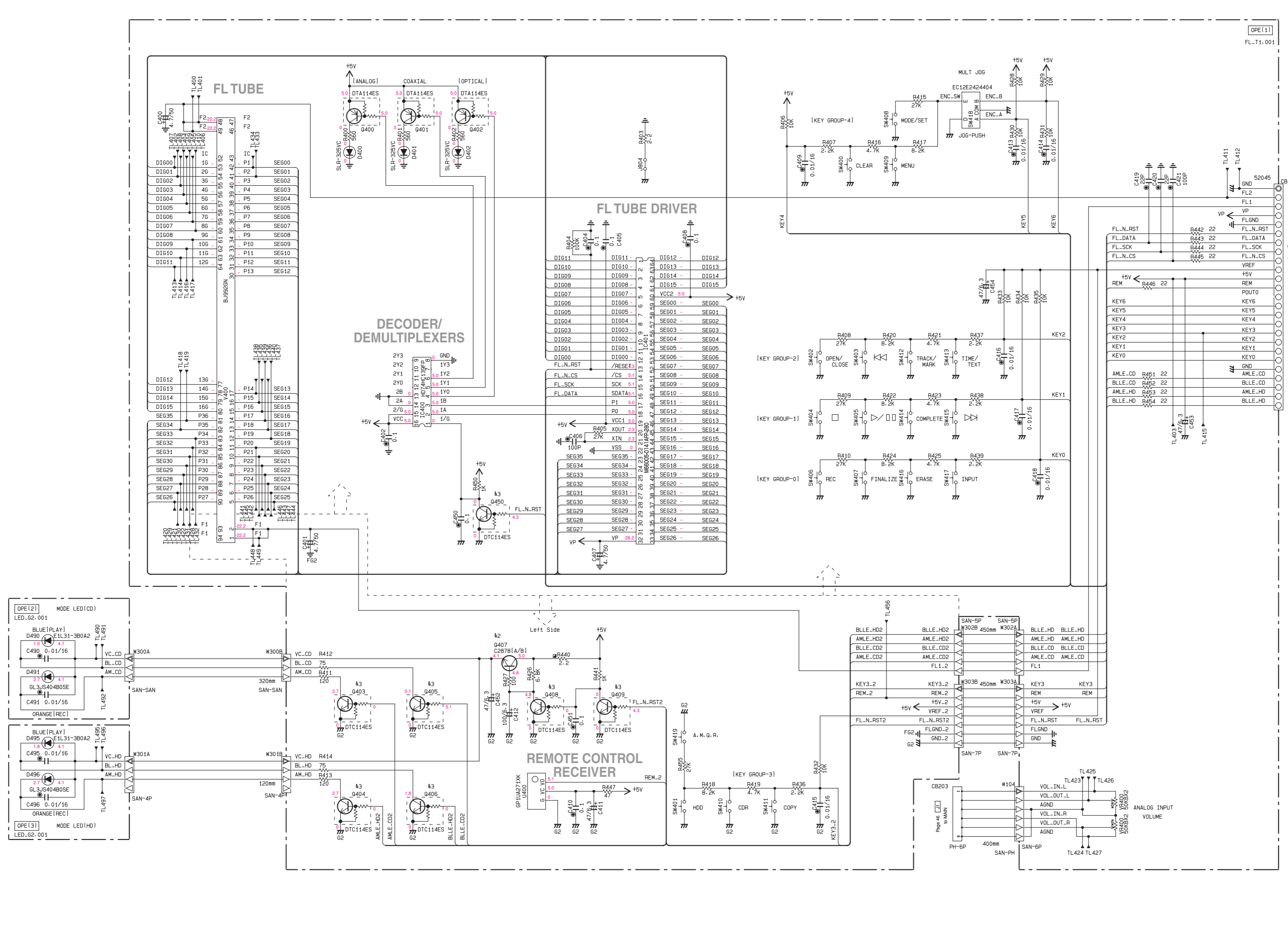

RESISTOR

REMARKS	PARTS NAME
NO MARK	CARBON FILM RESISTOR (P=5)
□	CARBON FILM RESISTOR (P=10)
△	METAL OXIDE FILM RESISTOR
▲	METAL FILM RESISTOR
△	METAL PLATE RESISTOR
■	FIRE PROOF CARBON FILM RESISTOR
□	CEMENT WOLDED RESISTOR
⊗	SEMI VARIABLE RESISTOR
■	CHIP RESISTOR

CAPACITOR

REMARKS	PARTS NAME
NO MARK	ELECTROLYTIC CAPACITOR
⊗	TANTALUM CAPACITOR
NO MARK	CERAMIC CAPACITOR
⊙	CERAMIC TUBULAR CAPACITOR
⊖	POLYESTER FILM CAPACITOR
○	POLYSTYRENE FILM CAPACITOR
○	MICA CAPACITOR
⊖	POLYPROPYLENE FILM CAPACITOR
●	SEMICONDUCTIVE CERAMIC CAPACITOR
⊖	POLYPHENYLENE SULFIDE FILM CAPACITOR

NOTICE (mode1)

(J)..... JAPAN
(U)..... U. S. A
(C)..... CANADA
(R)..... GENERAL
(T)..... CHINA
(K)..... KOREA
(A)..... AUSTRALIA
(B)..... BRITISH
(G)..... EUROPE
(L)..... SINGAPORE

Key Input (A-D) Pull-Up Resistance 10 k-ohms

Ohm	+2.2k	+4.7k	+8.2k	+22.0k
V	-1.5	-2.5	-3.5	-4.5
PUI KEY0	INPUT	ERASE	FINALIZE	REC
PUI KEY1	FF/SKIP+	COMPLETE	PLAY/PAUSE	STOP
PUI KEY2	TEXT/TIME	TRACK NO/BOOKMARK	REW/SKIP-	OPEN/CLOSE
PUI KEY3	COPY	CDR	HDD	A.M.Q.R.
PUI KEY4	CLEAR	MENU	ENTER (MULTI JOG)	MODE

- ★ All voltage are measured with a 10MΩ/V DC electric volt meter.
- ★ Components having special characteristics are marked **!** and must be replaced with parts having specifications equal to those originally installed.
- ★ Schematic diagram is subject to change without notice.
- 電圧は、内部抵抗10MΩの電圧計で測定したものです。
- !印のある部品は、安全性確保部品を示しています。部品の交換が必要な場合、パーツリストに記載されている部品を使用してください。
- 本回路図は標準回路図です。改良のため予告なく変更することがございます。

1
2
3
4
5
6
7
8
9

■ SCHEMATIC DIAGRAM (OPERATION 2/2)

REMARKS	PARTS NAME
NO MARK	CARBON FILM RESISTOR (P=5)
⊠	CARBON FILM RESISTOR (P=10)
△	METAL OXIDE FILM RESISTOR
⊡	METAL FILM RESISTOR
⊞	METAL PLATE RESISTOR
⊞	FIRE PROOF CARBON FILM RESISTOR
□	CEMENT MOLDED RESISTOR
⊞	SEMI VARIABLE RESISTOR
■	CHIP RESISTOR

REMARKS	PARTS NAME
NO MARK	ELECTROLYTIC CAPACITOR
⊗	TANTALUM CAPACITOR
NO MARK	CERAMIC CAPACITOR
⊙	CERAMIC TUBULAR CAPACITOR
⊙	POLYESTER FILM CAPACITOR
○	POLYSTYRENE FILM CAPACITOR
○	MICA CAPACITOR
⊙	POLYPROPYLENE FILM CAPACITOR
⊙	SEMICONDUCTIVE CERAMIC CAPACITOR
⊙	POLYPHENYLENE SULFIDE FILM CAPACITOR

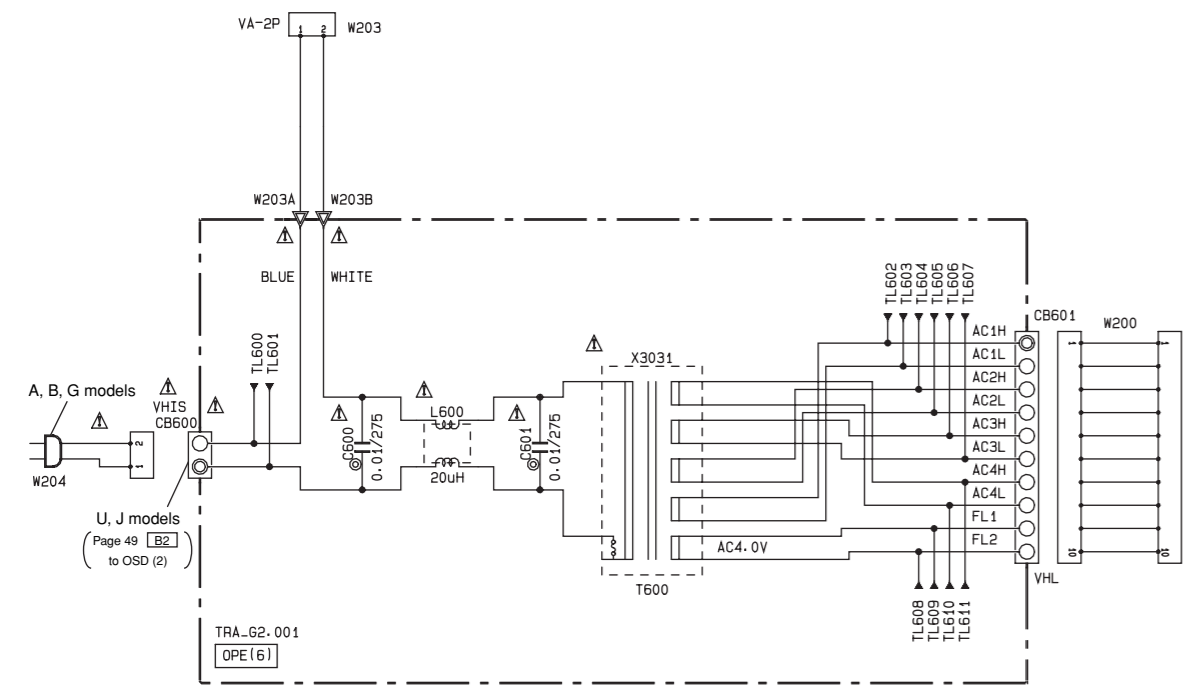
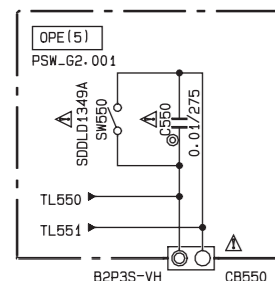

NOTICE (model)

(J)..... JAPAN
 (U)..... U. S. A
 (C)..... CANADA
 (R)..... GENERAL
 (T)..... CHINA
 (K)..... KOREA
 (A)..... AUSTRALIA
 (B)..... BRITISH
 (G)..... EUROPE
 (L)..... SINGAPORE

model	PartsNo.
J	XY619A0
U	X0211A0
A	X0212A0
B-G	X0213A0

- ★ All voltage are measured with a 10MΩ/DC electric volt meter.
- ★ Components having special characteristics are marked Δ and must be replaced with parts having specifications equal to those originally installed.
- ★ Schematic diagram is subject to change without notice.
- 電圧は、内部抵抗10MΩの電圧計で測定したものです。
- 上印のある部品は、安全性確保部品を示しています。部品の交換が必要な場合、パーツリストに記載されている部品を使用してください。
- 本回路図は標準回路図です。改良のため予告なく変更することがございます。

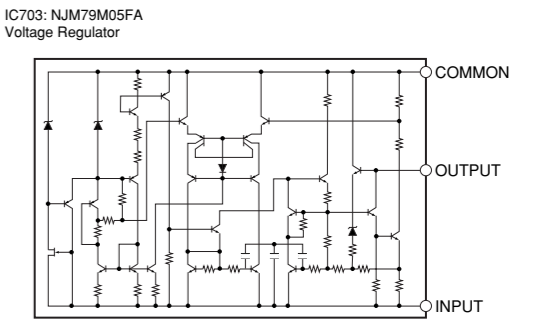
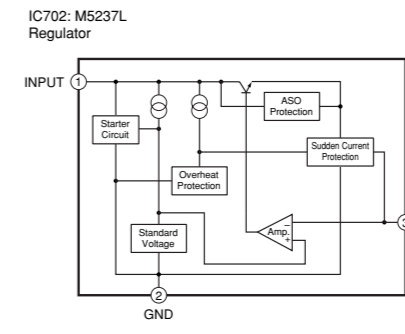
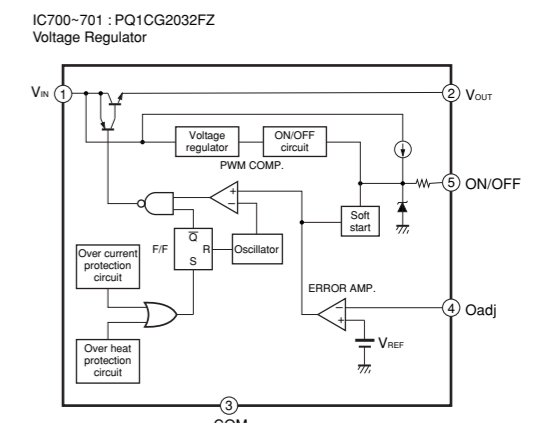
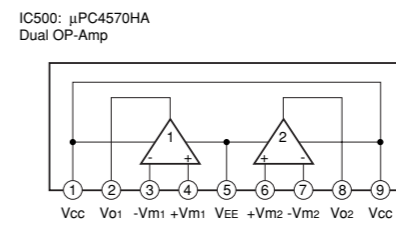

PIN CONNECTION DIAGRAM OF TRANSISTORS, DIODES AND ICs.

2SA933S DTC114ES	2SB1314 2SD2594	1SR139-400 MTZJ5.6B MTZJ11.0A MTZJ30.0D	SF5S6	D2SB20 D3SB20
1SVB20	M5237L	NJM79M05FA	PQ1CG2032FZ	μPC4570HA-A

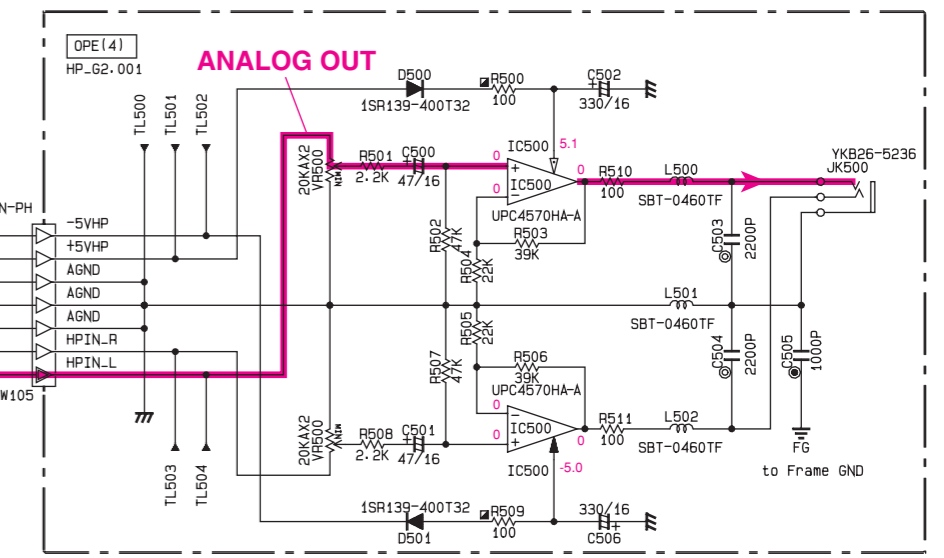

SCHEMATIC DIAGRAM (OSD)

RESISTOR	
REMARKS	PARTS NAME
NO MARK	CARBON FILM RESISTOR (P=5)
□	CARBON FILM RESISTOR (P=10)
△	METAL OXIDE FILM RESISTOR
▲	METAL FILM RESISTOR
⊠	METAL PLATE RESISTOR
⊞	FIRE PROOF CARBON FILM RESISTOR
⊞	CEMENT MOLDED RESISTOR
⊞	SEMI VARIABLE RESISTOR
■	CHIP RESISTOR

CAPACITOR	
REMARKS	PARTS NAME
NO MARK	ELECTROLYTIC CAPACITOR
⊗	TANTALUM CAPACITOR
NO MARK	CERAMIC CAPACITOR
●	CERAMIC TUBULAR CAPACITOR
⊙	POLYESTER FILM CAPACITOR
○	POLYSTYRENE FILM CAPACITOR
⊖	MICA CAPACITOR
⊕	POLYPROPYLENE FILM CAPACITOR
⊕	SEMICONDUCTIVE CERAMIC CAPACITOR
Ⓢ	POLYPHENYLENE SULFIDE FILM CAPACITOR

NOTICE (mode1)
 (J)..... JAPAN
 (U)..... U.S.A
 (C)..... CANADA
 (R)..... GENERAL
 (T)..... CHINA
 (K)..... KOREA
 (A)..... AUSTRALIA
 (B)..... BRITISH
 (G)..... EUROPE
 (L)..... SINGAPORE

	J	U	A-B-G
s1	CB952	M1908-G V656120	M1908-G V656120
s2-s3	W950A W950B	V946870	V946870
s4	XL950	14.31818MHZ VY94980	14.31818MHZ VY94980
s5	C967	390P US06239	390P US06239
s6	C968	1500P US06315	1500P US06315
s7	R955	X	R035410 10

Interchangeable Parts at Manufacture-Stage		
Mark	Reference Parts Number	Parts Name
△	Q952	2SA1037K(Q/R/S) 2SA1037AK(Q/R/S) 2SB709A(P/Q/R/S)

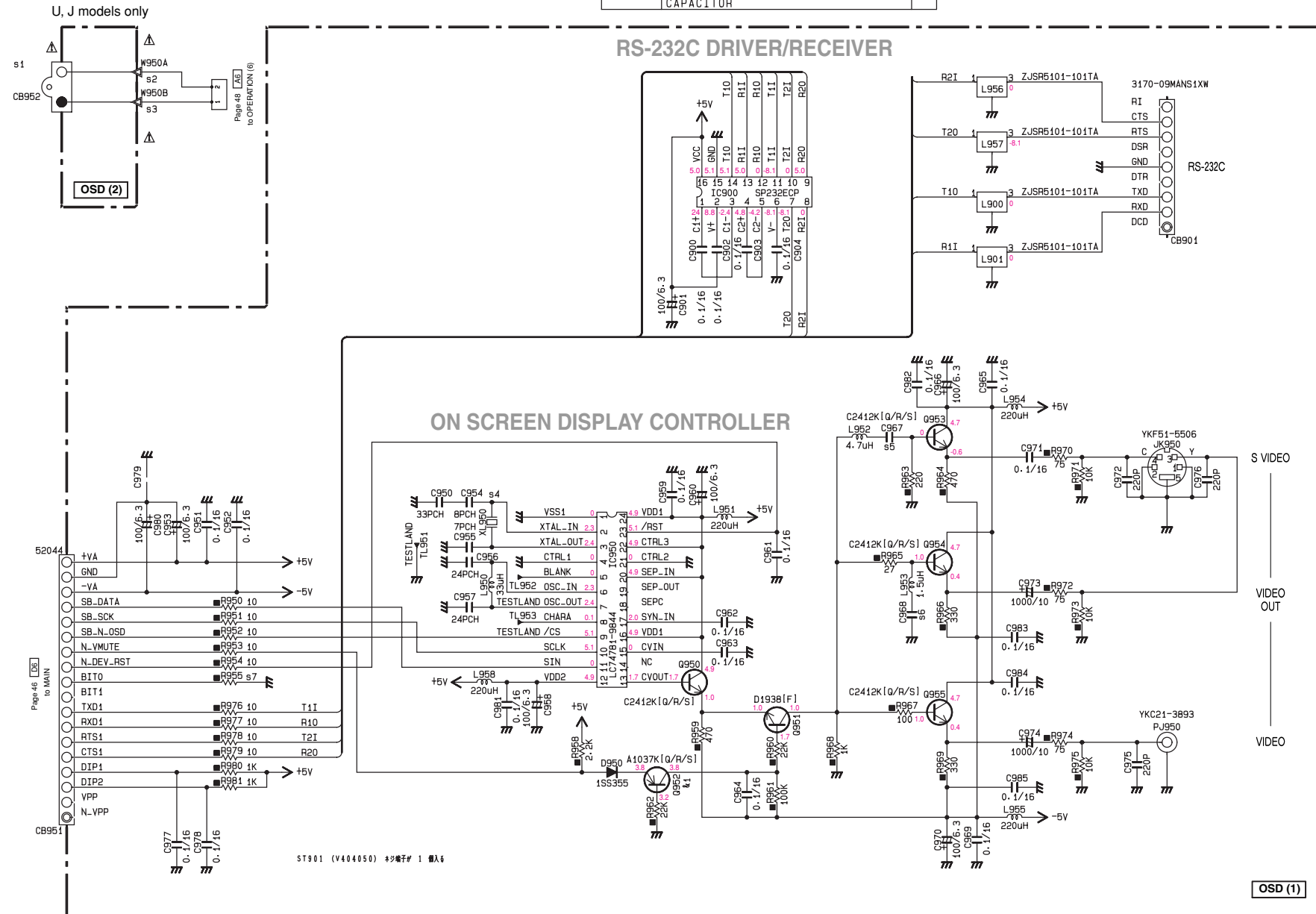

PIN CONNECTION DIAGRAM OF TRANSISTORS, DIODES AND ICs.

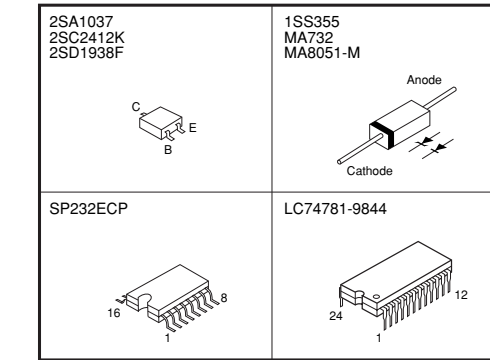

IC950: LC74781-9844
On Screen Display Controller

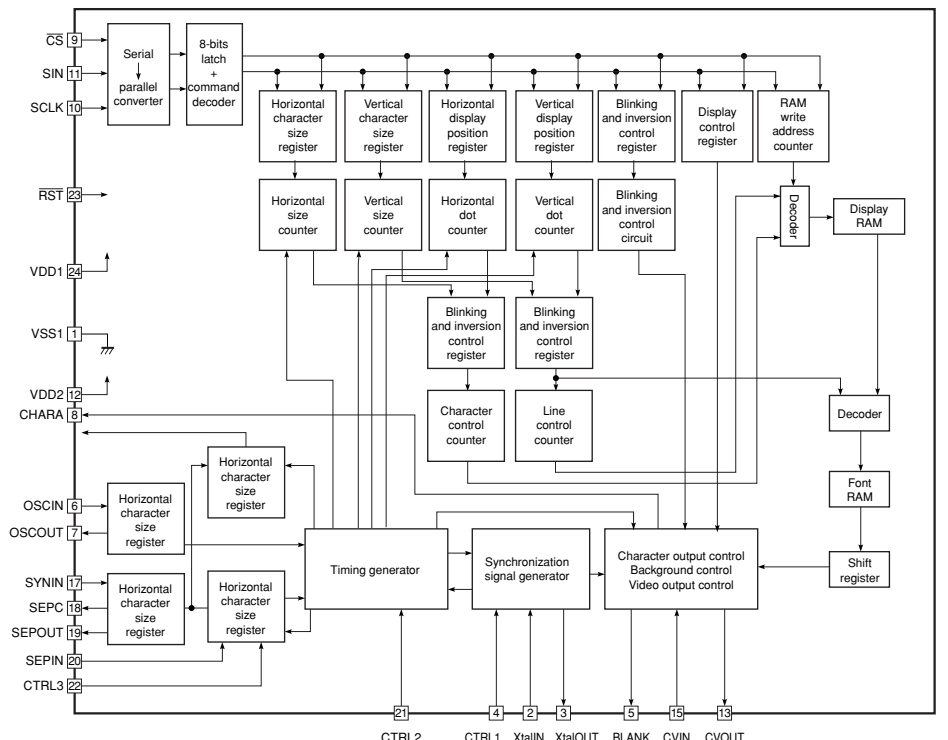

- ★ All voltage are measured with a 10MΩ/V DC electric volt meter.
- ★ Components having special characteristics are marked △ and must be replaced with parts having specifications equal to those originally installed.
- ★ Schematic diagram is subject to change without notice.
- 電圧は、内部抵抗10MΩの電圧計で測定したものです。
- △印のある部品は、安全性確保部品を示しています。部品の交換が必要な場合、パーツリストに記載されている部品を使用してください。
- 本回路図は標準回路図です。改良のため予告なく変更することがございます。

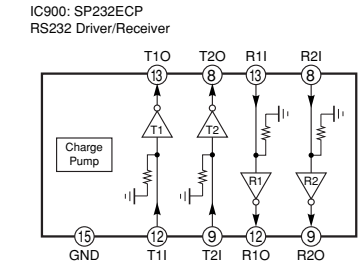

SCHEMATIC DIAGRAM (WCLK)

NOTICE (model)
 (J)..... JAPAN
 (U)..... U. S. A
 (C)..... CANADA
 (R)..... GENERAL
 (T)..... CHINA
 (K)..... KOREA
 (A)..... AUSTRALIA
 (B)..... BRITISH
 (G)..... EUROPE
 (L)..... SINGAPORE

REMARKS	PARTS NAME
NO MARK	CARBON FILM RESISTOR (P=5)
☒	CARBON FILM RESISTOR (P=10)
△	METAL OXIDE FILM RESISTOR
▲	METAL FILM RESISTOR
☒	METAL PLATE RESISTOR
☒	FIRE PROOF CARBON FILM RESISTOR
□	CEMENT MOLDED RESISTOR
⊗	SEMI VARIABLE RESISTOR
■	CHIP RESISTOR

REMARKS	PARTS NAME
NO MARK	ELECTROLYTIC CAPACITOR
⊗	TANTALUM CAPACITOR
NO MARK	CERAMIC CAPACITOR
●	CERAMIC TUBULAR CAPACITOR
◎	POLYESTER FILM CAPACITOR
○	POLYSTYRENE FILM CAPACITOR
①	MICA CAPACITOR
⊙	POLYPROPYLENE FILM CAPACITOR
●	SEMICONDUCTIVE CERAMIC CAPACITOR
⊙	POLYPHENYLENE SULFIDE FILM CAPACITOR

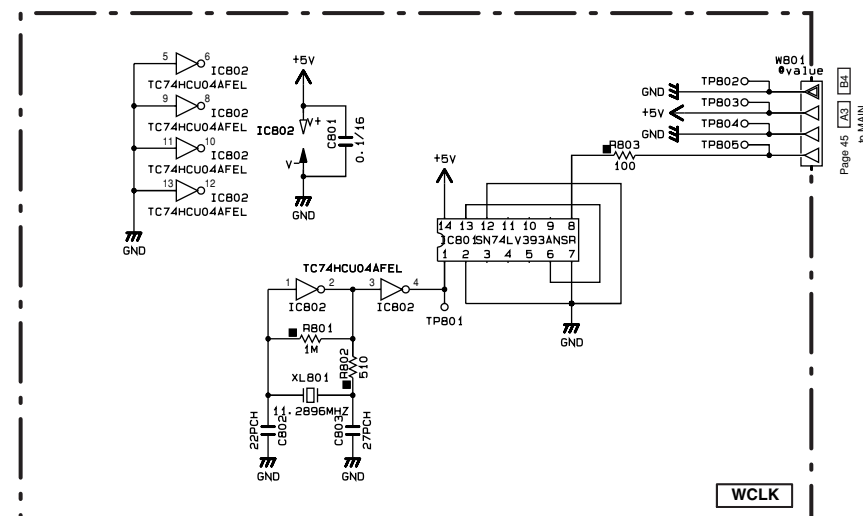

IC801: SN74LV393ANSR
Dual 4-Bit Binary Counters

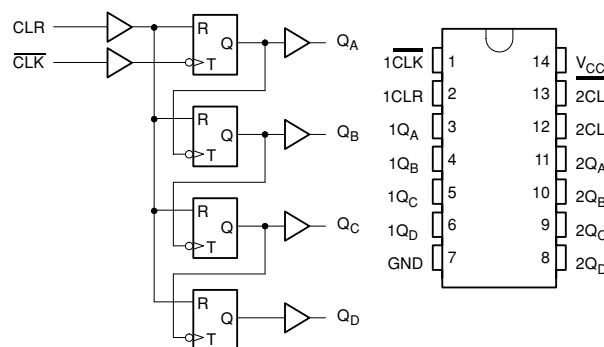

IC802: TC74HCU04AFEL
Hex Inverters

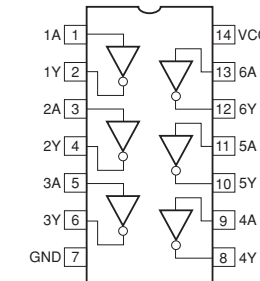

PIN CONNECTION DIAGRAM OF TRANSISTORS, DIODES AND ICs.

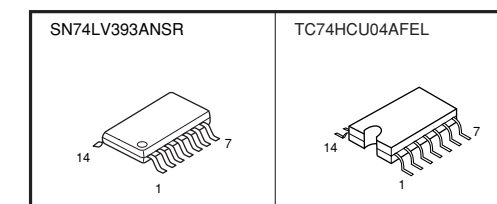

- ★ All voltage are measured with a 10MΩ/V DC electric volt meter.
- ★ Components having special characteristics are marked △ and must be replaced with parts having specifications equal to those originally installed.
- ★ Schematic diagram is subject to change without notice.
- 電圧は、内部抵抗10MΩの電圧計で測定したものです。
- △印のある部品は、安全性確保部品を示しています。部品の交換が必要な場合、パーツリストに記載されている部品を使用してください。
- 本回路図は標準回路図です。改良のため予告なく変更することがございます。

PRINTED CIRCUIT BOARD (Foil side)

Semiconductor Location

Ref. No.	Location	Ref. No.	Location	Ref. No.	Location	Ref. No.	Location
D1	D5	IC1	D6	IC200	C6	Q1	D4
D2	D4	IC2	D5	IC201	C4	Q2	D4
D3	I4	IC3	C3	IC202	D4	Q3	H4
D200	D6	IC4	D6	IC203	E4	Q200	E5
D201	C5	IC5	B5	IC204	E4	Q201	E5
D202	C5	IC7	D3	IC205	E4	Q202	E5
D203	E5	IC8	D6	IC206	E5	Q203	E5
D204	E5	IC9	D4	IC208	C4	Q204	E5
D205	C4	IC11	C5	IC210	E4		

MAIN P.C.B.

(Side A) Lead Solder Used

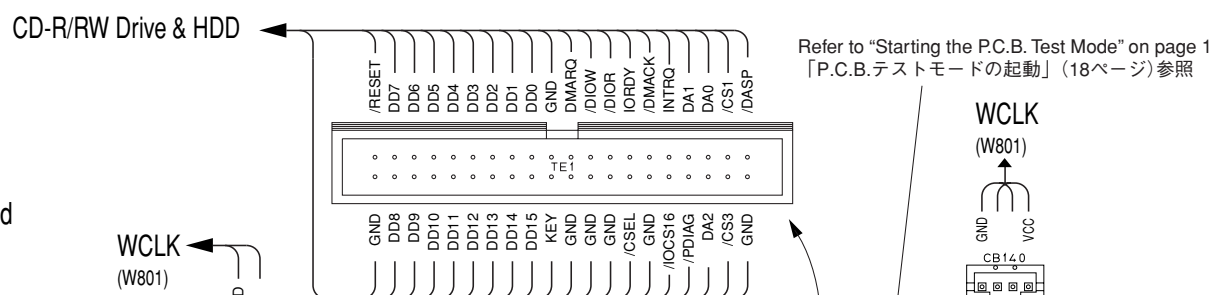

MAIN P.C.B.

(Side B) Lead Free Solder Used

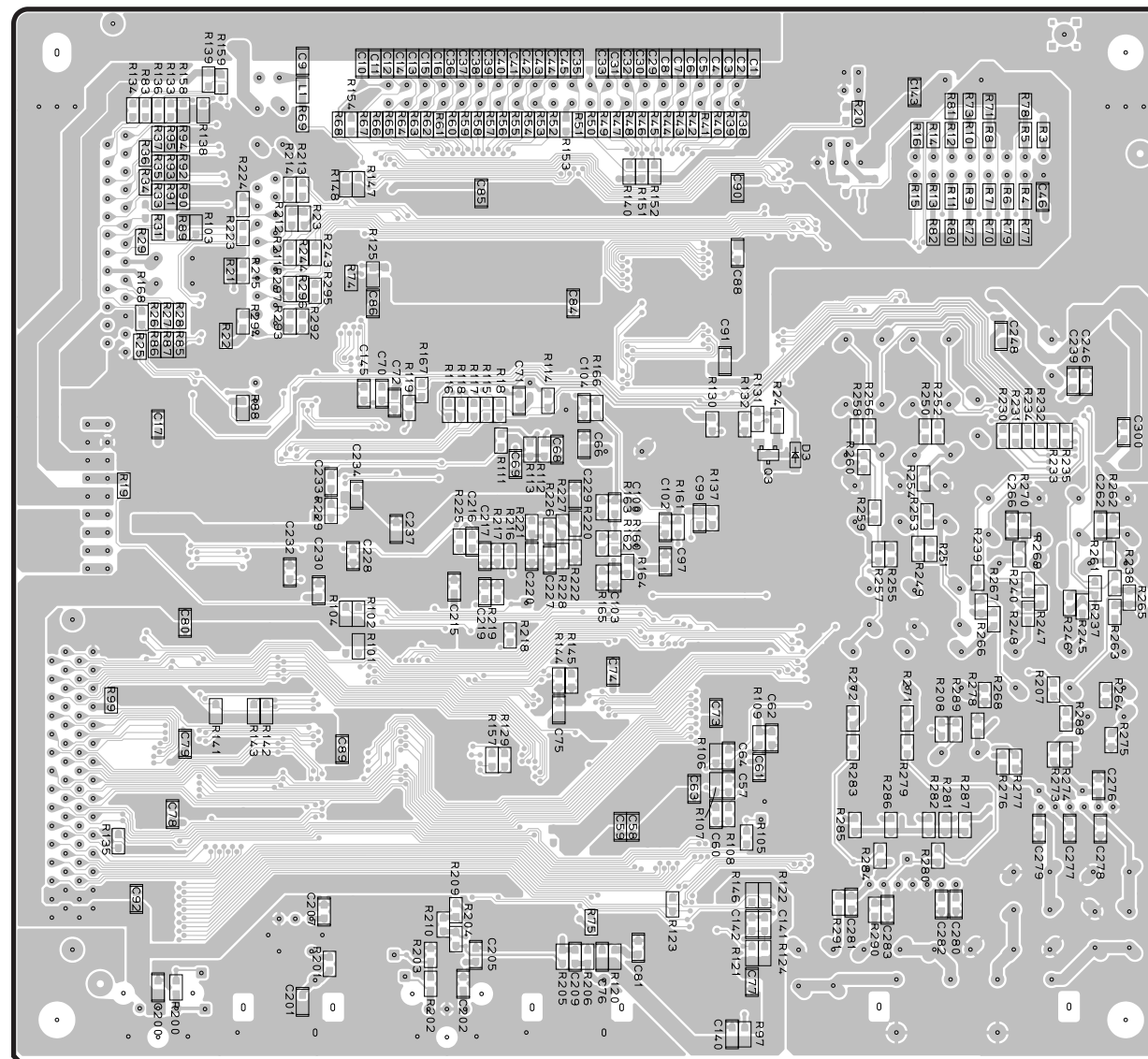

OPERATION (1)

(CB400)

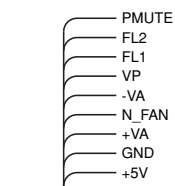
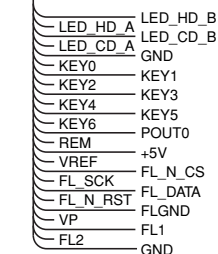

OPERATION (7)

(W100)

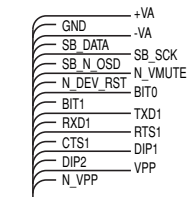

OSD (1)

(CB951)

OPTICAL COAXIAL DIGITAL OUT

OPTICAL COAXIAL DIGITAL IN

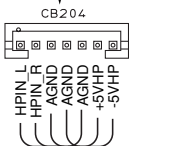

OPERATION (4) (W105)

LINE OUT L/R (PLAY) LINE IN L/R (REC) ANALOG

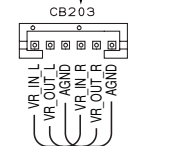

OPERATION (1) (W104)

PRINTED CIRCUIT BOARD (Foil side)

OPERATION (1) P. C. B. (Side A)

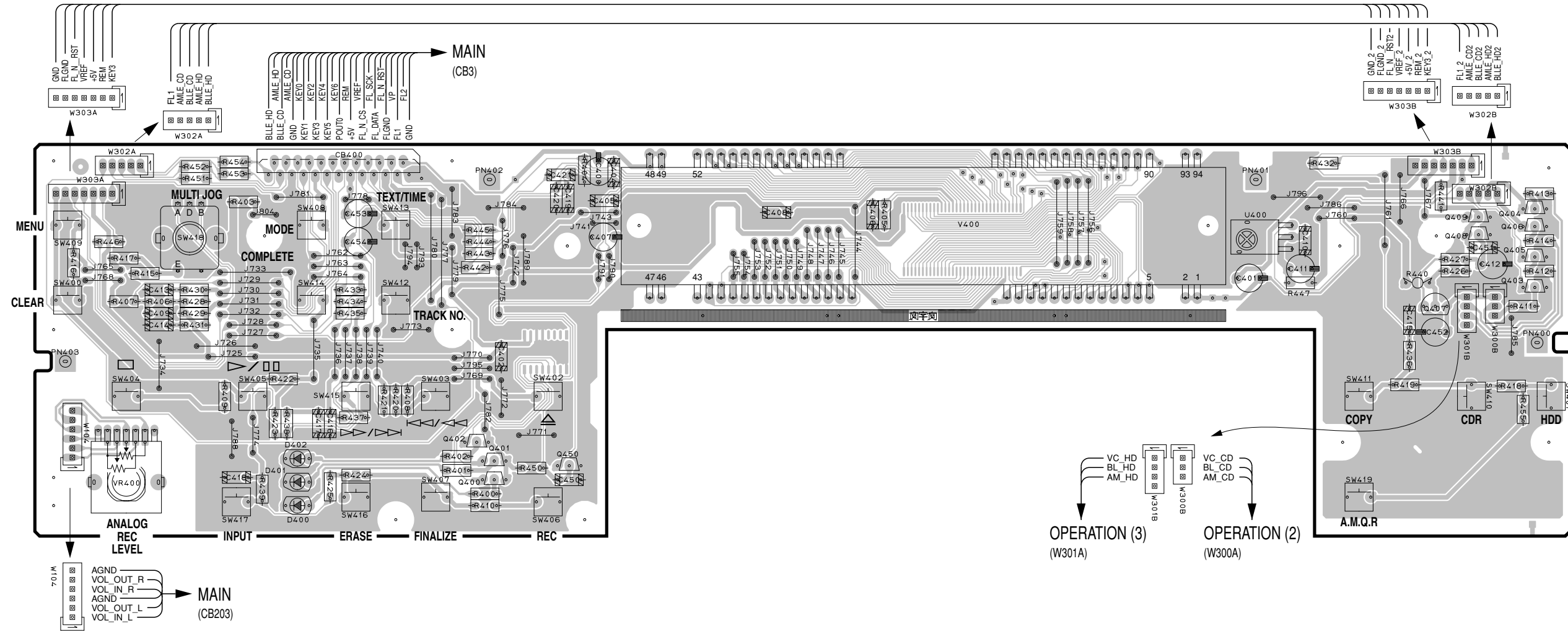

• Semiconductor Location

Ref. No.	Location
D400	B4
D401	B4
D402	B4
IC400	D6
IC401	F6
Q400	C4
Q401	C4
Q402	C4
Q403	I3
Q404	I3
Q405	I3
Q406	I3
Q407	H3
Q408	I3
Q409	I3
Q450	D4

OPERATION (1) P. C. B. (Side B) Lead Free Solder Used

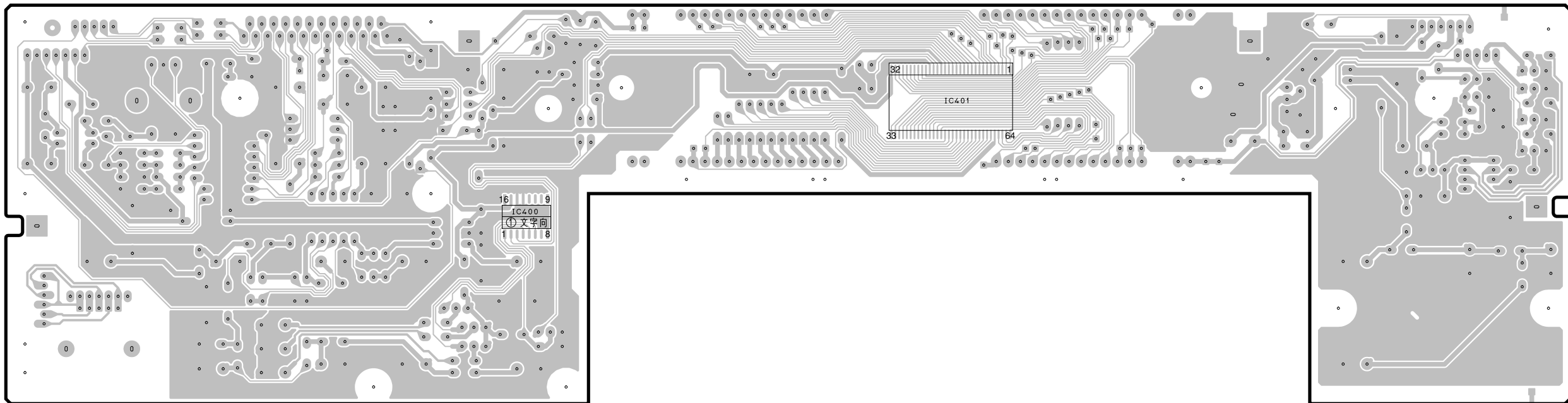

• Semiconductor Location

Ref. No.	Location
D490	A2
D491	A2
D495	B3
D496	B3
D500	D2
D501	D2
D700	H3
D701	G3
D702	G4
D703	G4
D704	E2
D710	E4
D711	F4
D712	H2
D713	H2
D714	G2
D715	G2
D716	E4
D717	E4
D718	E3
D719	F3
D720	F3
D721	F2
D722	F2
D723	F2
D750	H3
D751	H3
D752	H3
D753	G2
D754	G2
IC500	D2
IC700	G2
IC701	F2
IC702	F3
IC703	E4
Q700	F2
Q702	E2
Q703	F3
Q750	H3
Q751	H3

■ PRINTED CIRCUIT BOARD (Foil side) Lead Free Solder Used

OPERATION (2) P. C. B.

(Side A)

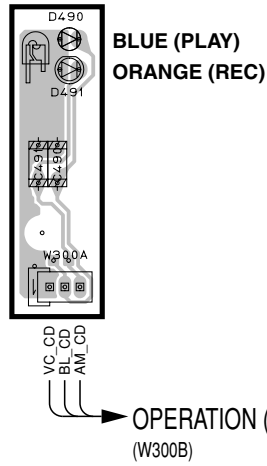

OPERATION (3) P. C. B.

(Side A)

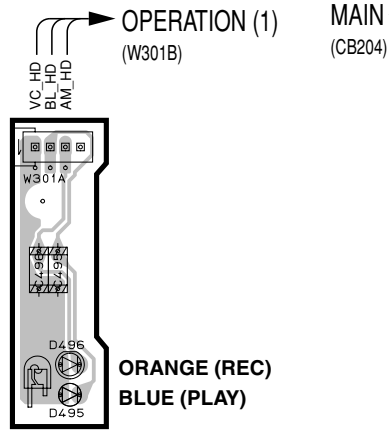

OPERATION (4) P. C. B.

(Side A)

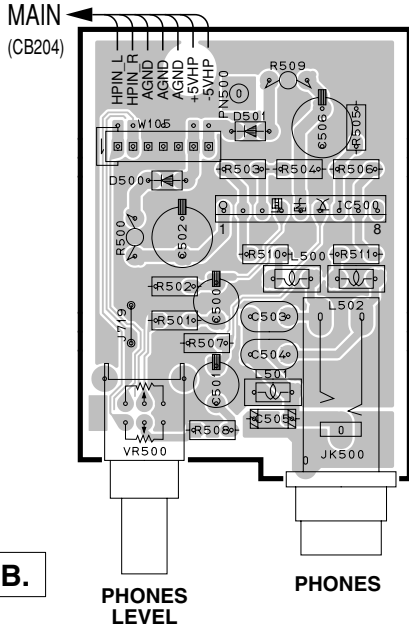

OPERATION (7) P. C. B.

(Side A)

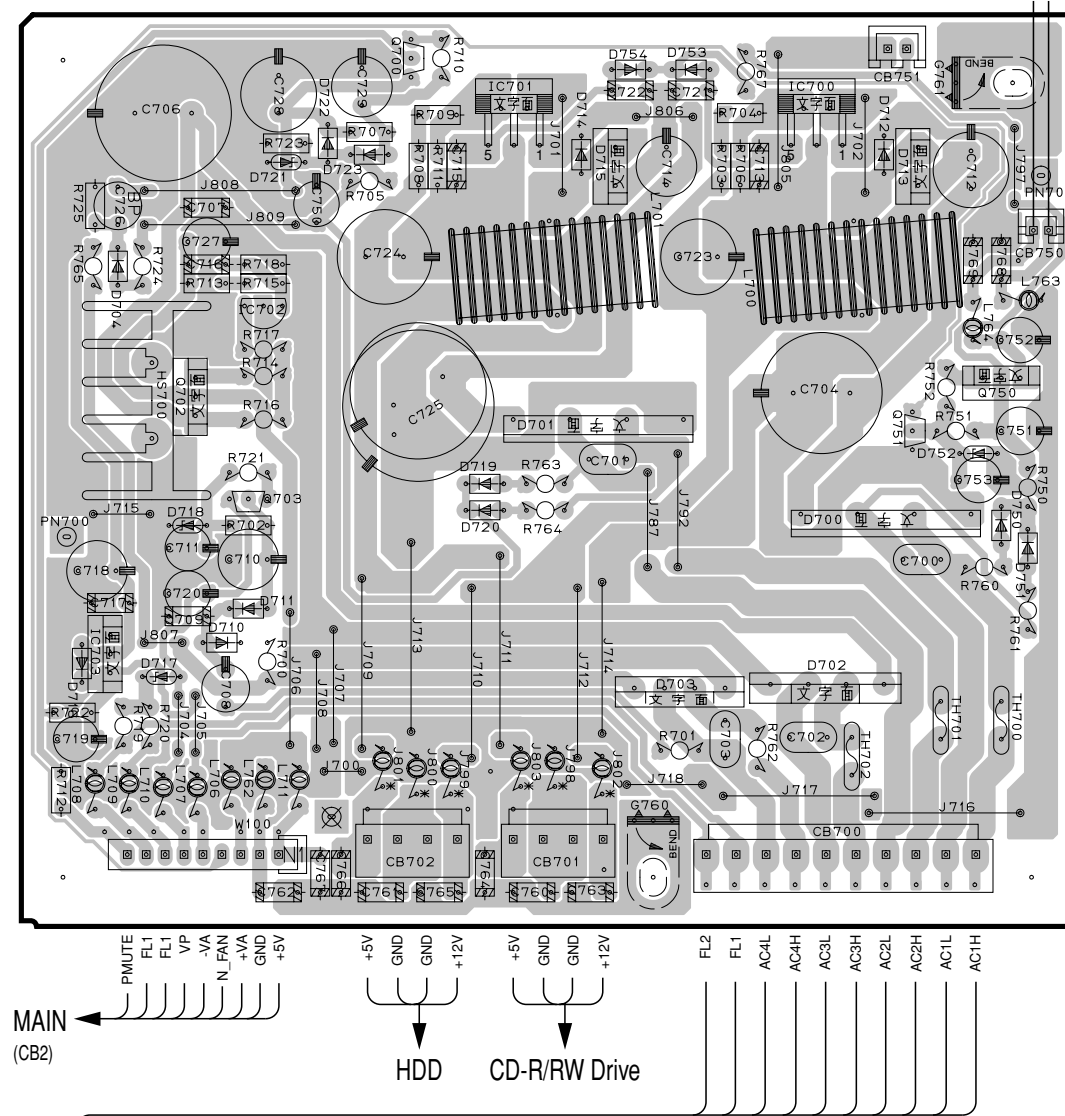

OPERATION (5) P. C. B.

(Side A)

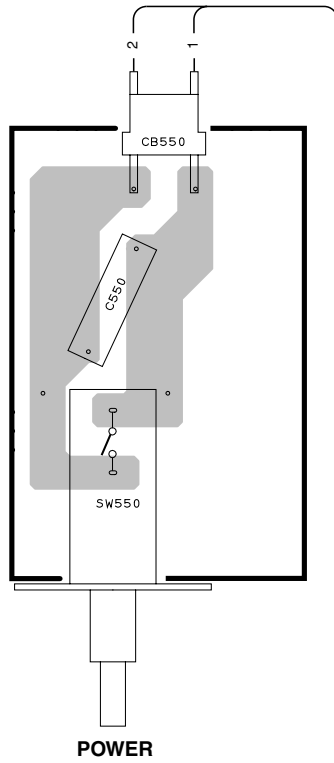

OPERATION (6) P. C. B.

(Side A)

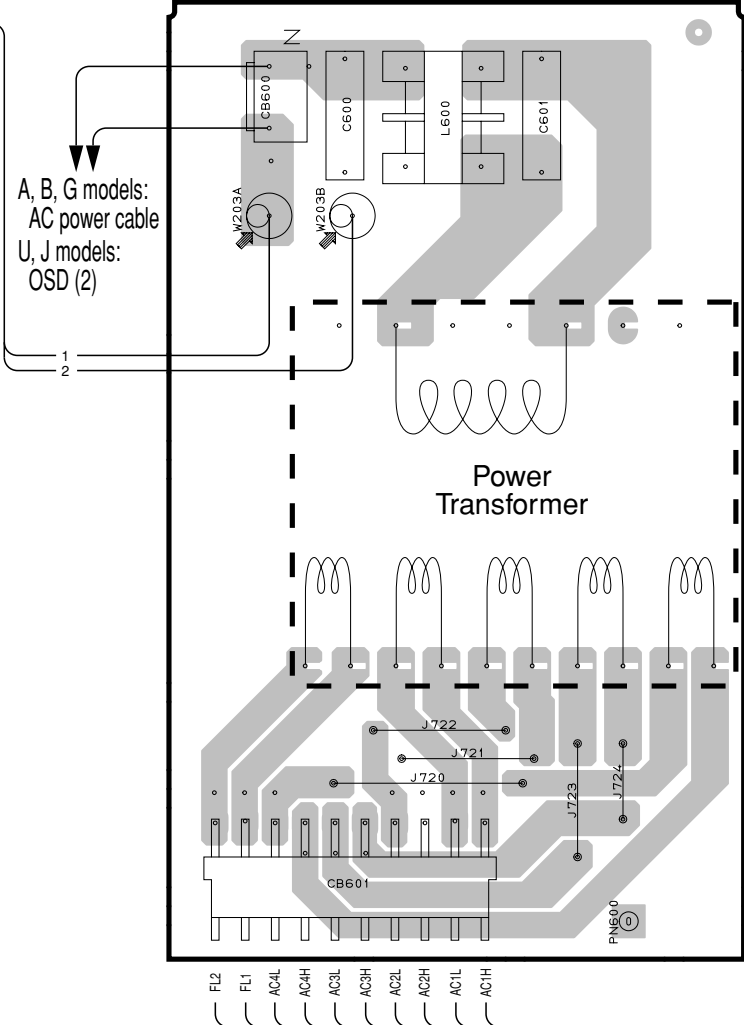

A, B, G models:
AC power cable
U, J models:
OSD (2)

PRINTED CIRCUIT BOARD (Foil side)

OSD (1) P. C. B. (Side A)

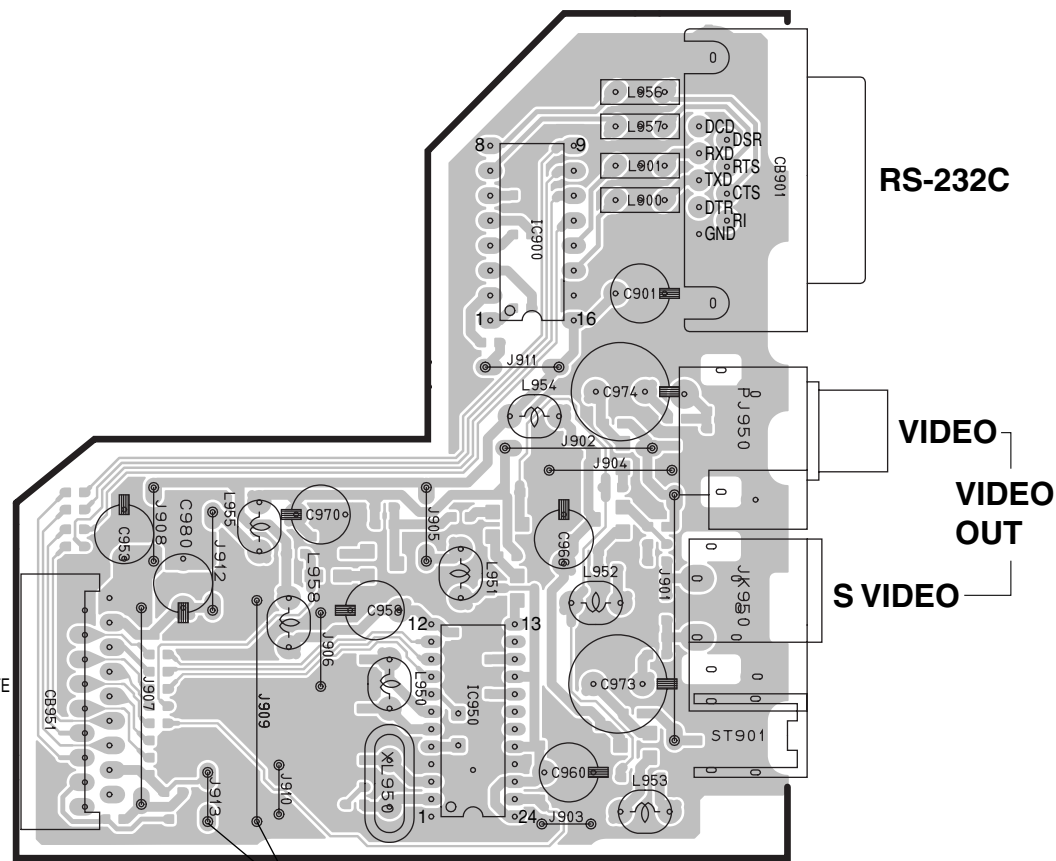

OSD (1) P. C. B. (Side B) Lead Free Solder Used

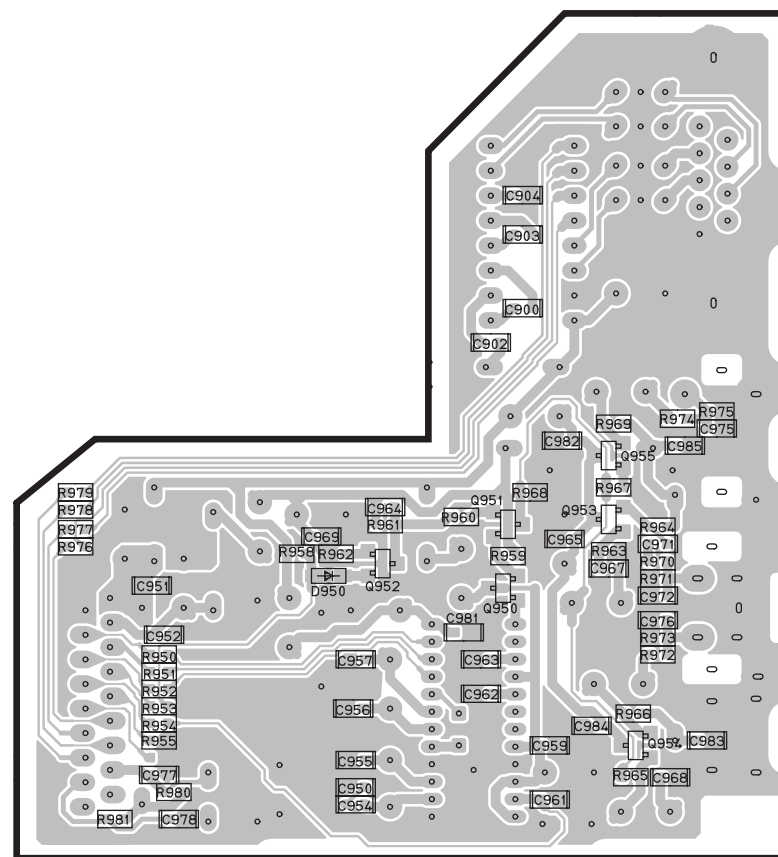

WCLK P. C. B. (Side A)

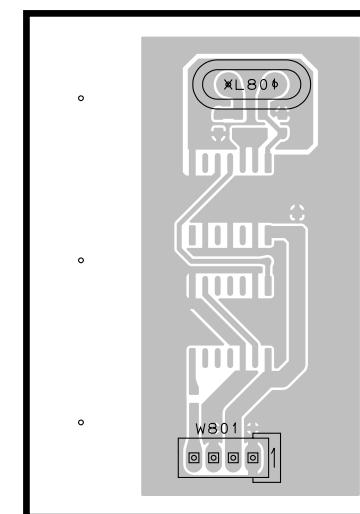

MAIN
(CB1) (CB140)

WCLK P. C. B. (Side B) Lead Free Solder Used

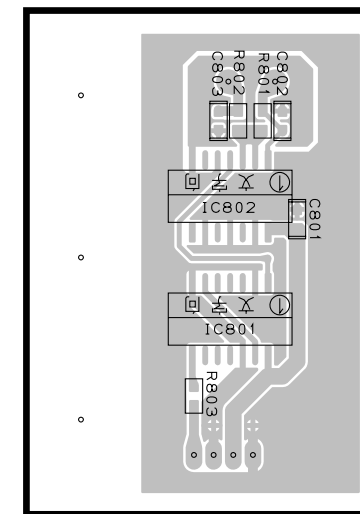

• Semiconductor Location

Ref. No.	Location
D950	F4
IC900	D2
IC950	C4
Q950	G4
Q951	G3
Q952	G4
Q953	G3
Q954	G4
Q955	G3

Circuit No.	J	U	A, B, G
CB952	O	O	X
R955	X	X	O
W950A, 950B	O	O	X

X: NOT USED
O: USED / APPLICABLE

OSD (2) P. C. B. (Side A)

U, J models

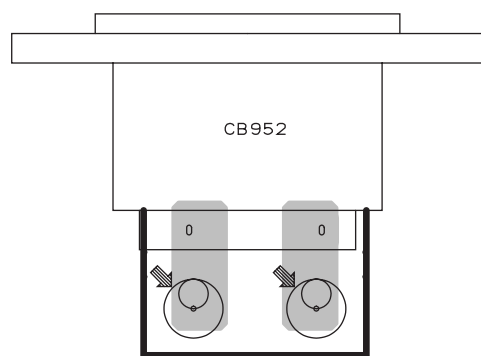

OPERATION (6)
(CB600)

• Semiconductor Location

Ref. No.	Location
IC801	I6
IC802	I5

PARTS LIST

■ ELECTRICAL PARTS

■ WARNING

● Components having special characteristics are marked \triangle and must be replaced with parts having specifications equal to those originally installed.

● \triangle 印のある部分は、安全確保部品を示しています。部品の交換が必要な場合、パーツリストに記載されている部品を使用してください。

● 部品価格ランクは、予告なく変更することがあります。

ABBREVIATIONS IN THIS LIST ARE AS FOLLOWS:

C.A.EL.CHP	: CHIP ALUMI.ELECTROLYTIC CAP	L.EMIT	: LIGHT EMITTING MODULE
C.CE	: CERAMIC CAP	LED.DSPLY	: LED DISPLAY
C.CE.ARRAY	: CERAMIC CAP ARRAY	LED.INFRD	: LED,INFRARED
C.CE.CHP	: CHIP CERAMIC CAP	MODUL.RF	: MODULATOR,RF
C.CE.ML	: MULTILAYER CERAMIC CAP	PHOT.CPL	: PHOTO COUPLER
C.CE.M.CHP	: CHIP MULTILAYER CERAMIC CAP	PHOT.INTR	: PHOTO INTERRUPTER
C.CE.SAFTY	: RECOGNIZED CERAMIC CAP	PHOT.RFLCT	: PHOTO REFLECTOR
C.CE.TUBLR	: CERAMIC TUBULAR CAP	PIN.TEST	: PIN,TEST POINT
C.CE.SMI	: SEMI CONDUCTIVE CERAMIC CAP	PLST.RIVET	: PLASTIC RIVET
C.EL	: ELECTROLYTIC CAP	R.ARRAY	: RESISTOR ARRAY
C.MICA	: MICA CAP	R.CAR.	: CARBON RESISTOR
C.ML.FLM	: MULTILAYER FILM CAP	R.CAR.CHP	: CHIP RESISTOR
C.MP	: METALLIZED PAPER CAP	R.CAR.FP	: FLAME PROOF CARBON RESISTOR
C.MYLAR	: MYLAR FILM CAP	R.FUS	: FUSABLE RESISTOR
C.MYLAR.ML	: MULTILAYER MYLAR FILM CAP	R.MTL.CHP	: CHIP METAL FILM RESISTOR
C.PAPER	: PAPER CAPACITOR	R.MTL.FLM	: METAL FILM RESISTOR
C.PLS	: POLYSTYRENE FILM CAP	R.MTL.OXD	: METAL OXIDE FILM RESISTOR
C.POL	: POLYESTER FILM CAP	R.MTL.PLAT	: METAL PLATE RESISTOR
C.POLY	: POLYETHYLENE FILM CAP	RSNR.CE	: CERAMIC RESONATOR
C.PP	: POLYPROPYLENE FILM CAP	RSNR.CRYS	: CRYSTAL RESONATOR
C.TNTL	: TANTALUM CAP	R.TW.CEM	: TWIN CEMENT FIXED RESISTOR
C.TNTL.CHP	: CHIP TANTALUM CAP	R.WW	: WIRE WOUND RESISTOR
C.TRIM	: TRIMMER CAP	SCR.BND.HD	: BIND HEAD B-TITE SCREW
CN	: CONNECTOR	SCR.BW.HD	: BW HEAD TAPPING SCREW
CN.BS.PIN	: CONNECTOR,BASE PIN	SCR.CUP	: CUP TITE SCREW
CN.CANNON	: CONNECTOR,CANNON	SCR.TERM	: SCREW TERMINAL
CN.DIN	: CONNECTOR,DIN	SCR.TR	: SCREW,TRANSISTOR
CN.FLAT	: CONNECTOR,FLAT CABLE	SUPRT.PCB	: SUPPORT,P.C.B.
CN.POST	: CONNECTOR,BASE POST	SURG.PRTCT	: SURGE PROTECTOR
COIL.MX.AM	: COIL,AM MIX	SW.TACT	: TACT SWITCH
COIL.AT.FM	: COIL,FM ANTENNA	SW.LEAF	: LEAF SWITCH
COIL.DT.FM	: COIL,FM DETECT	SW.LEVER	: LEVER SWITCH
COIL.MX.FM	: COIL,FM MIX	SW.MICRO	: MICRO SWITCH
COIL.OUTPT	: OUTPUT COIL	SW.PUSH	: PUSH SWITCH
DIOD.ARRAY	: DIODE ARRAY	SW.RT.ENC	: ROTARY ENCODER
DIODE.BRG	: DIODE BRIDGE	SW.RT.MTR	: ROTARY SWITCH WITH MOTOR
DIODE.CHP	: CHIP DIODE	SW.RT	: ROTARY SWITCH
DIODE.VAR	: VARACTOR DIODE	SW.SLIDE	: SLIDE SWITCH
DIOD.Z.CHP	: CHIP ZENER DIODE	TERM.SP	: SPEAKER TERMINAL
DIODE.ZENR	: ZENER DIODE	TERM.WRAP	: WRAPPING TERMINAL
DSCR.CE	: CERAMIC DISCRIMINATOR	THRMST.CHP	: CHIP THERMISTOR
FER.BEAD	: FERRITE BEADS	TR.CHP	: CHIP TRANSISTOR
FER.CORE	: FERRITE CORE	TR.DGT	: DIGITAL TRANSISTOR
FET.CHP	: CHIP FET	TR.DGT.CHP	: CHIP DIGITAL TRANSISTOR
FL.DSPLY	: FLUORESCENT DISPLAY	TRANS	: TRANSFORMER
FLTR.CE	: CERAMIC FILTER	TRANS.PULS	: PULSE TRANSFORMER
FLTR.COMB	: COMB FILTER MODULE	TRANS.PWR	: POWER TRANSFORMER ASS'Y
FLTR.LC.RF	: LC FILTER,EMI	TUNER.AM	: TUNER PACK,AM
GND.MTL	: GROUND PLATE	TUNER.FM	: TUNER PACK,FM
GND.TERM	: GROUND TERMINAL	TUNER.PK	: FRONT-ENDTUNER PACK
HOLDER.FUS	: FUSE HOLDER	VR	: ROTARY POTENTIOMETER
IC.PRTCT	: IC PROTECTOR	VR.MTR	: POTENTIOMETER WITH MOTOR
JUMPER.CN	: JUMPER CONNECTOR	VR.SW	: POTENTIOMETER WITH ROTARY SW
JUMPER.TST	: JUMPER,TEST POINT	VR.SLIDE	: SLIDE POTENTIOMETER
L.DTCT	: LIGHT DETECTING MODULE	VR.TRIM	: TRIMMER POTENTIOMETER

Note) Those parts marked with “#” are not included in the P.C.B. ass'y.

P.C.B. MAIN

Ref. No.	Part No.	Description	Remarks	Markets	部 品 名	Rank
*	WF002400	P. C. B.	MAIN		P C B メイン	
	CB1	V4325300 CN	2P		CグリッドSLヘッダ	01
	CB2	VL845300 CN. BS. PIN	9P		ベース付ポスト	01
	CB3	VP082900 CN. BS. PIN	25P		FFCコネクタ	02
	CB4	V6451700 CN. BS. PIN	16P TE		ピンヘッダ	
	CB5	VB389800 CN. BS. PIN	2P		ベースピン	01
	CB140	VB390000 CN. BS. PIN	4P		ベースピン	01
	CB200	WB920900 CN. PHOT. SN	1P GP1FA513TZ0F		光ファイバデータ端子	03
	CB201	WB547900 CN. PHOT. SN	1P GP1FA513RZ0F		光ファイバ受信器	03
	CB202	VP573800 CN. BS. PIN	18P		FFCコネクタ	01
	CB203	VB390200 CN. BS. PIN	6P		コネクタベースポスト	01
	CB204	VB390300 CN. BS. PIN	7P		ベースピン	01
	C65	UR819100 C. EL	1000uF 6.3V		ケミコン	01
	C101	VR169200 C. MYLAR	ECQ-V1H474JL3		マイラーコン	01
	C240	UU219100 C. EL	1000uF 6.3V		ケミコン FW	01
	C244-245	UA653100 C. MYLAR	1000pF 50V J		マイラーコン	03
	C250-253	UU238100 C. EL	100uF 16V		ケミコン	01
*	C254	UU238220 C. EL	220uF 16V		ケミコン FW	
	C255	UA653150 C. MYLAR	1500pF 50V J		マイラーコン	01
*	C256	UU238220 C. EL	220uF 16V		ケミコン FW	
	C257	UA652220 C. MYLAR	220pF 50V J		マイラーコン	01
*	C258	UU238220 C. EL	220uF 16V		ケミコン FW	
	C259	UA653150 C. MYLAR	1500pF 50V J		マイラーコン	01
*	C260	UU238220 C. EL	220uF 16V		ケミコン FW	
	C261	UA652220 C. MYLAR	220pF 50V J		マイラーコン	01
	C263	UU267100 C. EL	10uF 50V		ケミコン FW	01
	C264-265	UU238100 C. EL	100uF 16V		ケミコン	01
	C267	UU267100 C. EL	10uF 50V		ケミコン FW	01
	C268	UA652220 C. MYLAR	220pF 50V J		マイラーコン	01
	C269-270	UU238100 C. EL	100uF 16V		ケミコン	01
	C271	UA652220 C. MYLAR	220pF 50V J		マイラーコン	01
	C272-273	UU238100 C. EL	100uF 16V		ケミコン	01
	C274-275	UU247470 C. EL	47uF 25V		ケミコン FW	01
	C284	UA652220 C. MYLAR	220pF 50V J		マイラーコン	01
	C285	UA652390 C. MYLAR	390pF 50V J		マイラーコン	01
	C286	UA652220 C. MYLAR	220pF 50V J		マイラーコン	01
	C287	UA652390 C. MYLAR	390pF 50V J		マイラーコン	01
	C288-289	UA653100 C. MYLAR	1000pF 50V J		マイラーコン	03
	D1	V0721800 DIODE. CHP	MA732		チップダイオード	01
	D2-3	VT332900 DIODE	1SS355		ダイオード	01
	D200	VU992600 DIODE. ZENR	MA8051-M 5.1V		ツェナーダイオード	01
	D201-205	VT332900 DIODE	1SS355		ダイオード	01
	IC1	XP985A00 IC	SN74LS06NST-EL INV		IC	
	IC2	XU147A00 IC	HD6417014F28 CPU		CPU/周辺IC	09
	IC3	XZ073A00 IC	YDC126-F		IC	09
	IC4	XL122A00 IC	PST572CMT-R		IC	02
	IC5	XV932B00 IC	MSM5118160F-60JSR1		メモリIC 16M	08
*	IC7	X0149B00 IC	GLT44016-40J4 DRAM		メモリIC 4M	
*	IC8	X6406A00 IC	TC74HC14AF(EL, F)		ロジックIC	
	IC9	XR339A00 IC	TC9246F-TEL PLL		ロジックIC	04
*	IC11	X6544B00 IC	MBM29F800BA-70FPTN		メモリIC TSOP	
	IC200	XD598A00 IC	TC74HCU04AFEL INV		ロジックIC	01
	IC201	XL091A00 IC	HD74HC02FPEL NOR		ロジックIC	01

* New Parts * 新規部品

P.C.B. MAIN & P.C.B. OPERATION

Ref. No.	Part No.	Description	Remarks	Markets	部 品 名	Rank
IC202	XV190A00	IC	NJM2904M OP AMP		アンプ I C	01
IC203-204	XQ185A00	IC	NJM2100M		I C	04
IC205	XZ331A00	IC	NJM4580E OP AMP		アンプ I C S O P	01
IC206	XG903A00	IC	TC4052BF MPX		I C	03
IC208	XW526A00	IC	YSD917		I C	07
IC210	XY624A00	IC	AK4528VF		A D C & D A C I C	08
PJ200-201	V4483900	JACK. PIN	1P YKC21-3895N		ピンジャック	
PJ202	V2020500	JACK. PIN	4P		ピンジャック	04
Q1	VV556400	TR	2SC2412K Q, R, S		トランジスタ	01
Q2	VV655400	TR. DGT	DTC114EKA		デジタルトランジスタ	01
Q3	VV556400	TR	2SC2412K Q, R, S		トランジスタ	01
Q200	VC123900	TR. DGT	DTA143EK		デジタルトランジスタ	03
Q201-204	VZ725900	TR	2SD1938F S, T		トランジスタ	
R1-2	HV753220	R. CAR. FP	2.2Ω 1/4W		不燃化カーボン抵抗	01
R155	HV753220	R. CAR. FP	2.2Ω 1/4W		不燃化カーボン抵抗	01
R236	HV753470	R. CAR. FP	4.7Ω 1/4W		不燃化カーボン抵抗	01
R241-242	HV753220	R. CAR. FP	2.2Ω 1/4W		不燃化カーボン抵抗	01
TE1	V5739200	CN. BS. PIN	2120-40SF1BN		ピンヘッダー	
TH1	VT518900	POSISTOR	NTH4G39A103F02 10K		温度検知用サーミスタ	03
XL1	VV762900	RSNR. CRYST	7MHz SMD-49		水晶振動子	03
XL2	V3625700	RSNR. CRYST	24.576MHz		水晶振動子	03
	V9443700	P. C. B.	OPERATION		P C B オペレーション	26
CB400	VP082900	CN. BS. PIN	25P		F F C コネクター	02
CB550	VP245600	CN	2P		ベース付ポスト	01
CB600	VG879900	CN. BS. PIN	2P		ベースピン	01
CB601	LB933100	CN. BS. PIN	10P SE		ベースポスト	02
CB700	LB932100	CN. BS. PIN	10P		ベースポスト	02
CB701-702	LB932040	CN. BS. PIN	4P		ベースポスト	01
CB750	VB389800	CN. BS. PIN	2P		ベースピン	01
CB751	LB918020	CN. BS. PIN	2P		ベース付ポスト	01
C400-401	UM416470	C. EL	4.7uF 50V		ケミコン	01
C402	VJ599100	C. CE. TUBLR	0.1uF 50V		円筒セラコン	01
C404-405	VJ599100	C. CE. TUBLR	0.1uF 50V		円筒セラコン	01
C406	VF466800	C. CE. TUBLR	100pF 50V		円筒セラコン	01
C407	UM416470	C. EL	4.7uF 50V		ケミコン	01
C408	VJ599100	C. CE. TUBLR	0.1uF 50V		円筒セラコン	01
C409	VF467300	C. CE. TUBLR	0.01uF 16V		円筒セラコン	01
C410	VJ599100	C. CE. TUBLR	0.1uF 50V		円筒セラコン	01
C411	UM387470	C. EL	47uF 16V		ケミコン	01
C412	UM388100	C. EL	100uF 10V		ケミコン	01
C413-418	VF467300	C. CE. TUBLR	0.01uF 16V		円筒セラコン	01
C419-420	VG276600	C. CE. TUBLR	22pF 50V		円筒セラコン	01
C421	VF466800	C. CE. TUBLR	100pF 50V		円筒セラコン	01
C450-451	VJ599100	C. CE. TUBLR	0.1uF 50V		円筒セラコン	01
C452-454	UM387470	C. EL	47uF 16V		ケミコン	01
C490-491	VF467300	C. CE. TUBLR	0.01uF 16V		円筒セラコン	01
C495-496	VF467300	C. CE. TUBLR	0.01uF 16V		円筒セラコン	01
C500-501	UR837470	C. EL	47uF 16V		ケミコン	01
C502	UR838330	C. EL	330uF 16V		ケミコン	01
C503-504	UA653470	C. MYLAR	4700pF 50V		マイラーコン	01

* New Parts * 新規部品

P.C.B. OPERATION

Ref. No.	Part No.	Description	Remarks	Markets	部 品 名	Rank
	C505	VJ599100 C. CE. TUBLR	0.1uF 50V		円筒セラコン	01
	C506	UR838330 C. EL	330uF 16V		ケミコン	01
△	C550	V3501400 C. CE. SAFTY	0.01uF 275V		規格認定コン	
△	C600-601	V3501400 C. CE. SAFTY	0.01uF 275V		規格認定コン	
	C700-703	UA654100 C. MYLAR	0.01uF 50V		マイラーコン	01
	C704	UR759470 C. EL	4700uF 35V		ケミコン	04
*	C706	WF203200 C. EL	10000uF 16V		ケミコン	
	C707	VJ599100 C. CE. TUBLR	0.1uF 50V		円筒セラコン	01
△	C708	UR867470 C. EL	47uF 50V		ケミコン	01
	C709	VJ599100 C. CE. TUBLR	0.1uF 50V		円筒セラコン	01
*	C710	WF203700 C. EL	100uF 50V		ケミコン	
	C711	UR866470 C. EL	4.7uF 50V		ケミコン	01
	C712	WB807600 C. EL	220uF 50V		ケミコン	01
	C713	VJ599100 C. CE. TUBLR	0.1uF 50V		円筒セラコン	01
*	C714	WF203600 C. EL	220uF 25V		ケミコン	
	C715	VJ599100 C. CE. TUBLR	0.1uF 50V		円筒セラコン	01
	C716	VF467000 C. CE. TUBLR	1000pF 50V		円筒セラコン	01
	C717	VJ599100 C. CE. TUBLR	0.1uF 50V		円筒セラコン	01
*	C718	WF203600 C. EL	220uF 25V		ケミコン	
*	C719	UR837470 C. EL	47uF 16V		ケミコン	01
*	C720	WF203800 C. EL	4.7uF 50V		ケミコン	
	C721-722	VJ599100 C. CE. TUBLR	0.1uF 50V		円筒セラコン	01
△	C723	WB807200 C. EL	1000uF 16V		ケミコン	01
*	C724	WF203300 C. EL	3300uF 16V		ケミコン	
*	C725	WF203400 C. EL	10000uF 25V		ケミコン	
	C726	UN837470 C. EL	47uF 16V		B P ケミコン	01
	C727	WB807100 C. EL	220uF 16V		ケミコン	01
	C728	UR848470 C. EL	470uF 25V		ケミコン	01
	C729	UR868100 C. EL	100uF 50V		ケミコン	01
	C750	UR837100 C. EL	10uF 16V		ケミコン	01
	C751	UR867470 C. EL	47uF 50V		ケミコン	01
	C752	UR837100 C. EL	10uF 16V		ケミコン	01
	C753	UR867220 C. EL	22uF 50V		ケミコン	01
	C760-769	VG279400 C. CE. TUBLR	2200pF 16V		円筒セラコン	01
	D400-402	VS132300 LED (re)	SLR-325VCT31		L E D	01
	D490	V7446300 LED	E1L31-3B0A2		L E D	
	D491	V7446400 LED	GL3JS404B0SE		L E D	
	D495	V7446300 LED	E1L31-3B0A2		L E D	
	D496	V7446400 LED	GL3JS404B0SE		L E D	
	D500-501	VU264100 DIODE	1SR139-400		ダイオード	01
△	D700-701	VN011300 DIODE. BRG	D3SBA20 4A 200V		ダイオード	03
	D702	V4269600 DIODE. BRG	D2SBA20 1.5A 200V		ダイオードブリッジ	
	D703	VQ379300 DIODE. BRG	S1VB20 1A 200V		ダイオード	02
	D704	VU264100 DIODE	1SR139-400		ダイオード	01
	D710-712	VU264100 DIODE	1SR139-400		ダイオード	01
	D713	V6591700 DIODE	SF5S6		ダイオード	
	D714	VU264100 DIODE	1SR139-400		ダイオード	01
	D715	V6591700 DIODE	SF5S6		ダイオード	
	D716	VU264100 DIODE	1SR139-400		ダイオード	01
	D717	VG437700 DIODE. ZENR	MTZJ5.6B 5.6V		ツェナーダイオード	01
	D718	VG443500 DIODE. ZENR	MTZJ30D 30V		ツェナーダイオード	01
△	D719-720	VU264100 DIODE	1SR139-400		ダイオード	01
	D721	VG437400 DIODE. ZENR	MTZJ5.1B 5.1V		ツェナーダイオード	01

* New Parts * 新規部品

P.C.B. OPERATION

Ref. No.	Part No.	Description	Remarks	Markets	部 品 名	Rank	
	D722-723	VU264100	DIODE	1SR139-400		ダイオード	01
△	D750-751	VU264100	DIODE	1SR139-400		ダイオード	01
	D752	VG439800	DIODE. ZENR	MTZJ11A 11V		ツェナーダイオード	01
	D753-754	VU264100	DIODE	1SR139-400		ダイオード	01
	IC400	XU532A00	IC	HD74HC139FPEL 2-4		ロジックIC SOP	02
	IC401	X4194A00	IC	M66005-0141AFP-280		IC	06
	IC500	XB247A00	IC	μPC4570HA-A		IC	02
	IC700-701	XY525A00	IC	P01CG2032FZ		電源IC SIL	06
	IC702	Xi165A00	IC	M5237L		IC	02
	IC703	XE436A00	IC	NJM79M05FA		IC	03
	JK500	V5129000	JACK. PHONE	YKB26-5236		ヘッドホンジャック	03
	PN400-403	V8637500	PIN	L=50		スタイルピン	01
	PN500	V8637500	PIN	L=50		スタイルピン	01
	PN600	V9637500	PIN	L=70		スタイルピン	
	PN700	V9637500	PIN	L=70		スタイルピン	
	PN701	V8637500	PIN	L=50		スタイルピン	01
	Q400-402	VD678500	TR. DGT	DTA114ES		デジタルトランジスタ	01
	Q403-406	VD678700	TR. DGT	DTC114ES		デジタルトランジスタ	01
	Q407	iC287820	TR	2SC2878 A,B		トランジスタ	01
	Q408-409	VD678700	TR. DGT	DTC114ES		デジタルトランジスタ	01
	Q450	VD678700	TR. DGT	DTC114ES		デジタルトランジスタ	01
△	Q700	iA093320	TR	2SA933S Q,R		トランジスタ	01
	Q702	V2650900	TR	2SB1314 E,F		トランジスタ	02
△	Q703	iA093320	TR	2SA933S Q,R		トランジスタ	01
	Q750	VS883400	TR	2SD2394 E,F		トランジスタ	02
	Q751	VD678700	TR. DGT	DTC114ES		デジタルトランジスタ	01
	R440	HV753220	R. CAR. FP	2.2Ω 1/4W		不燃化カーボン抵抗	01
	R500	HV755100	R. CAR. FP	100Ω 1/4W		不燃化カーボン抵抗	01
	R509	HV755100	R. CAR. FP	100Ω 1/4W		不燃化カーボン抵抗	01
△	R700	HV753220	R. CAR. FP	2.2Ω 1/4W		不燃化カーボン抵抗	01
△	R701	HV755100	R. CAR. FP	100Ω 1/4W		不燃化カーボン抵抗	01
△	R705	HV755100	R. CAR. FP	100Ω 1/4W		不燃化カーボン抵抗	01
	R710	HV755100	R. CAR. FP	100Ω 1/4W		不燃化カーボン抵抗	01
	R714	HV753100	R. CAR. FP	1Ω 1/4W		不燃化カーボン抵抗	01
	R716	HV755180	R. CAR. FP	180Ω 1/4W		不燃化カーボン抵抗	01
	R717	HV754470	R. CAR. FP	47Ω 1/4W		不燃化カーボン抵抗	01
	R719-721	HV755100	R. CAR. FP	100Ω 1/4W		不燃化カーボン抵抗	01
△	R724	HV754100	R. CAR. FP	10Ω 1/4W		不燃化カーボン抵抗	01
△	R750	HV753220	R. CAR. FP	2.2Ω 1/4W		不燃化カーボン抵抗	01
	R751	HV756220	R. CAR. FP	2.2KΩ 1/4W		不燃化カーボン抵抗	01
	R752	HV755100	R. CAR. FP	100Ω 1/4W		不燃化カーボン抵抗	01
△	R760-761	HV753220	R. CAR. FP	2.2Ω 1/4W		不燃化カーボン抵抗	01
△	R762	HV753330	R. CAR. FP	3.3Ω 1/4W		不燃化カーボン抵抗	01
△	R763-764	HV753220	R. CAR. FP	2.2Ω 1/4W		不燃化カーボン抵抗	01
△	R765	VP940300	R. MTL. OXD	68Ω 1W		酸化金属被膜抵抗	01
	R767	HV753100	R. CAR. FP	1Ω 1/4W		不燃化カーボン抵抗	01
	SW400-417	V4757100	SW. TACT	EVQ11A		タクトSW	01
	SW418	V7597700	SW. RT. ENC	EC12E2424404		ロータリーエンコーダ	04
	SW419	V4757100	SW. TACT	EVQ11A		タクトSW	01
△	SW550	VZ364100	SW. PUSH	SDDL1-A2-F-1		プッシュSW	03
	TH700-701	VV458000	SW	RUE250 2.50A 30V		ポリスイッチ	03
	TH702	VV457600	SW	RUE090 0.90A 30V		ポリスイッチ	02
	U400	V8085300	L. DTCT	GP1UA271X		リモコン受光ユニット	04

* New Parts * 新規部品

P.C.B. OPERATION & P.C.B. OSD & P.C.B. WCLK

Ref. No.	Part No.	Description	Remarks	Markets	部 品 名	Rank
V400	V9468600	FL. DSPLY	BJ992GN		蛍光表示管	
VR400	V6619600	VR	B50KΩ RK14K12C0		二連ロータリーVR	03
VR500	V7502400	VR	A20KΩ RK09L12B0		二連ロータリーVR	04
	V0859800	SHEET			シート/FL	01
	V8080700	SPACER. FL			スペーサ/FL	
	V6100600	SUPRT			サポート/FL	
	V8297500	SPACER	6RB V744630		LED スペーサ	
	EG330030	SCR. BND. HD	3x6 MFC2BL		バインド小ネジ	01
	V9443800	P. C. B.	OSD		P C B O S D	12
	V9443900	P. C. B.	OSD		P C B O S D	
	V9444000	P. C. B.	OSD		P C B O S D	
CB901	V6509500	SOCKET	9P SE 3170		コネクタソケット	04
CB951	V0044800	CN. BS. PIN	18P		FFCコネクタ	01
CB952	V6561200	AC INLET	2P M1908-G		ACインレット 2P	02
C901	UR818100	C. EL	100uF 6.3V		ケミコン	01
C953	UR818100	C. EL	100uF 6.3V		ケミコン	01
C958	UR818100	C. EL	100uF 6.3V		ケミコン	01
C960	UR818100	C. EL	100uF 6.3V		ケミコン	01
C966	UR818100	C. EL	100uF 6.3V		ケミコン	01
C967	US062390	C. CE. CHP	390pF 50V		チップセラコン	01
C967	US062270	C. CE. CHP	270pF 50V		チップセラコン	01
C968	US063150	C. CE. CHP	1500pF 50V		チップセラコン	01
C968	US062820	C. CE. CHP	820pF 50V		チップセラコン	01
C970	UR818100	C. EL	100uF 6.3V		ケミコン	01
C973-974	UR829100	C. EL	1000uF 10V		ケミコン	01
C980	UR818100	C. EL	100uF 6.3V		ケミコン	01
D950	VT332900	DIODE	1SS355		ダイオード	01
IC900	X0226A00	IC	SP232ECP		IC	04
IC950	X3030A00	IC	LC74781-9844		IC DIP	07
JK950	V6931000	CN. DIN	1P YKF51-5506		1連S端子	02
L900-901	V9771300	FLTR. LC. RF	ZJSR5101-101TA		ノイズフィルター EMI	01
L956-957	V9771300	FLTR. LC. RF	ZJSR5101-101TA		ノイズフィルター EMI	01
PJ950	V9643000	JACK. PIN	1P YE YKC21-3893		ピンジャック	01
Q950	VV556400	TR	2SC2412K Q, R, S		トランジスタ	01
Q951	VZ725900	TR	2SD1938F S, T		トランジスタ	
Q952	iA103700	TR. CHP	2SA1037 Q, R, S		チップトランジスタ	01
Q953-955	VV556400	TR	2SC2412K Q, R, S		トランジスタ	01
ST901	V4040500	SCR. TERM	M3		スクリュー/ターミナル	01
XL950	VV949800	RSNR. CRYST	14.31818MHz		水晶振動子	03
XL950	VV949900	RSNR. CRYST	17.734475MHz		水晶振動子	03
	WE860700	P. C. B.	WCLK		P C B W C L K	
*	IC801	X3577A00	IC		ロジックIC	
*	IC802	XD598A00	IC		ロジックIC	01
*	XL801	WE239800	RSNR. CRYST		水晶振動子	

* New Parts * 新規部品

Chip Parts

Ref. No.	Part No.	Description	Remarks	Markets	部 品 名	Rank
	UF017470	C. EL. CHP 47uF 6. 3V			チップケミコン	01
	UF018100	C. EL. CHP 100uF 6. 3V			チップケミコン	01
	UF027330	C. EL. CHP 33uF 10V			チップケミコン	01
	UF037100	C. EL. CHP 10uF 16V			チップケミコン	01
	UF037220	C. EL. CHP 22uF 16V			チップケミコン	01
	UF066100	C. EL. CHP 1uF 50V			チップケミコン	01
	US044220	C. CE. CHP 0. 022uF 25V B			チップセラコン	01
	US060700	C. CE. CHP 7pF 50V			チップセラコン	01
	US060800	C. CE. CHP 8pF 50V			チップセラコン	01
	US061100	C. CE. CHP 10pF 50V B			チップセラコン	01
	US061150	C. CE. CHP 15pF 50V B			チップセラコン	01
	US061220	C. CE. M. CHP 22pF 50V			チップセラコン	01
	US061240	C. CE. CHP 24pF 50V			チップセラコン (C H)	01
	US061270	C. CE. M. CHP 27pF 50V			チップセラコン	01
	US061330	C. CE. M. CHP 33pF 50V			チップセラコン	01
	US062100	C. CE. CHP 100pF 50V B			チップセラコン	01
	US062150	C. CE. CHP 150pF 50V B			チップセラコン	01
	US062220	C. CE. CHP 220pF 50V			チップセラコン	01
	US062270	C. CE. M. CHP 270pF 50V			チップセラコン	01
	US062330	C. CE. CHP 330pF 50V B			チップセラコン	01
	US062390	C. CE. CHP 390pF 50V			チップセラコン (S L)	01
	US062470	C. CE. CHP 470pF 50V B			チップセラコン	01
	US062820	C. CE. CHP 820pF 50V			チップセラコン (B)	01
	US063100	C. CE. CHP 1000pF 50V B			チップセラコン	01
	US063150	C. CE. M. CHP 1500pF 50V			チップセラコン	01
	US063470	C. CE. CHP 4700pF 50V B			チップセラコン	01
	US135100	C. CE. CHP 0. 1uF 16V			チップセラコン	01
	US163100	C. CE. CHP 1000pF 50V			チップセラコン	01
	RD354100	R. CHP 10Ω 1/16W J			チップ抵抗	01
	RD354220	R. CHP 22Ω 1/16W J			チップ抵抗	01
	RD354270	R. CHP 27Ω 1/16W			チップ抵抗	01
	RD354470	R. CHP 47Ω 1/16W J			チップ抵抗	01
	RD354750	R. CHP 75Ω 1/16W			チップ抵抗	01
	RD355100	R. CHP 100Ω 1/16W J			チップ抵抗	01
	RD355150	R. CHP 150Ω 1/16W J			チップ抵抗	01
	RD355220	R. CHP 220Ω 1/16W			チップ抵抗	01
	RD355330	R. CHP 330Ω 1/16W J			チップ抵抗	01
	RD355470	R. CHP 470Ω 1/16W			チップ抵抗	01
	RD355510	R. CHP 510Ω 1/16W			チップ抵抗	01
	RD356100	R. CHP 1KΩ 1/16W J			チップ抵抗	01
	RD356150	R. CHP 1. 5KΩ 1/16W J			チップ抵抗	01
	RD356220	R. CHP 2. 2KΩ 1/16W J			チップ抵抗	01
	RD356330	R. CHP 3. 3KΩ 1/16W J			チップ抵抗	01
	RD356470	R. CHP 4. 7KΩ 1/16W J			チップ抵抗	01
	RD356560	R. CHP 5. 6KΩ 1/16W J			チップ抵抗	01
	RD357100	R. CHP 10KΩ 1/16W J			チップ抵抗	01
	RD357220	R. CHP 22KΩ 1/16W J			チップ抵抗	01
	RD357470	R. CHP 47KΩ 1/16W J			チップ抵抗	01
	RD357560	R. CHP 56KΩ 1/16W J			チップ抵抗	01
	RD357910	R. CHP 91KΩ 1/16W J			チップ抵抗	01
	RD358100	R. CHP 100KΩ 1/16W J			チップ抵抗	01
	RD358220	R. CHP 220KΩ 1/16W J			チップ抵抗	01
	RD358470	R. CHP 470KΩ 1/16W J			チップ抵抗	01

* New Parts * 新規部品

Chip Parts

Ref. No.	Part No.	Description	Remarks	Markets	部 品 名	Rank
	RD359100	R. CHP 1MΩ 1/16W J			チップ抵抗	01
	RF356470	R. MTL. CHP 4. 7KΩ 1/16W D			チップ金属被膜抵抗	01
	RF356560	R. MTL. CHP 5. 6KΩ 1/16W D			チップ金属被膜抵抗	01
	RF357100	R. MTL. CHP 10KΩ 1/16W D			チップ金属被膜抵抗	01

* New Parts * 新規部品

EXPLODED VIEW

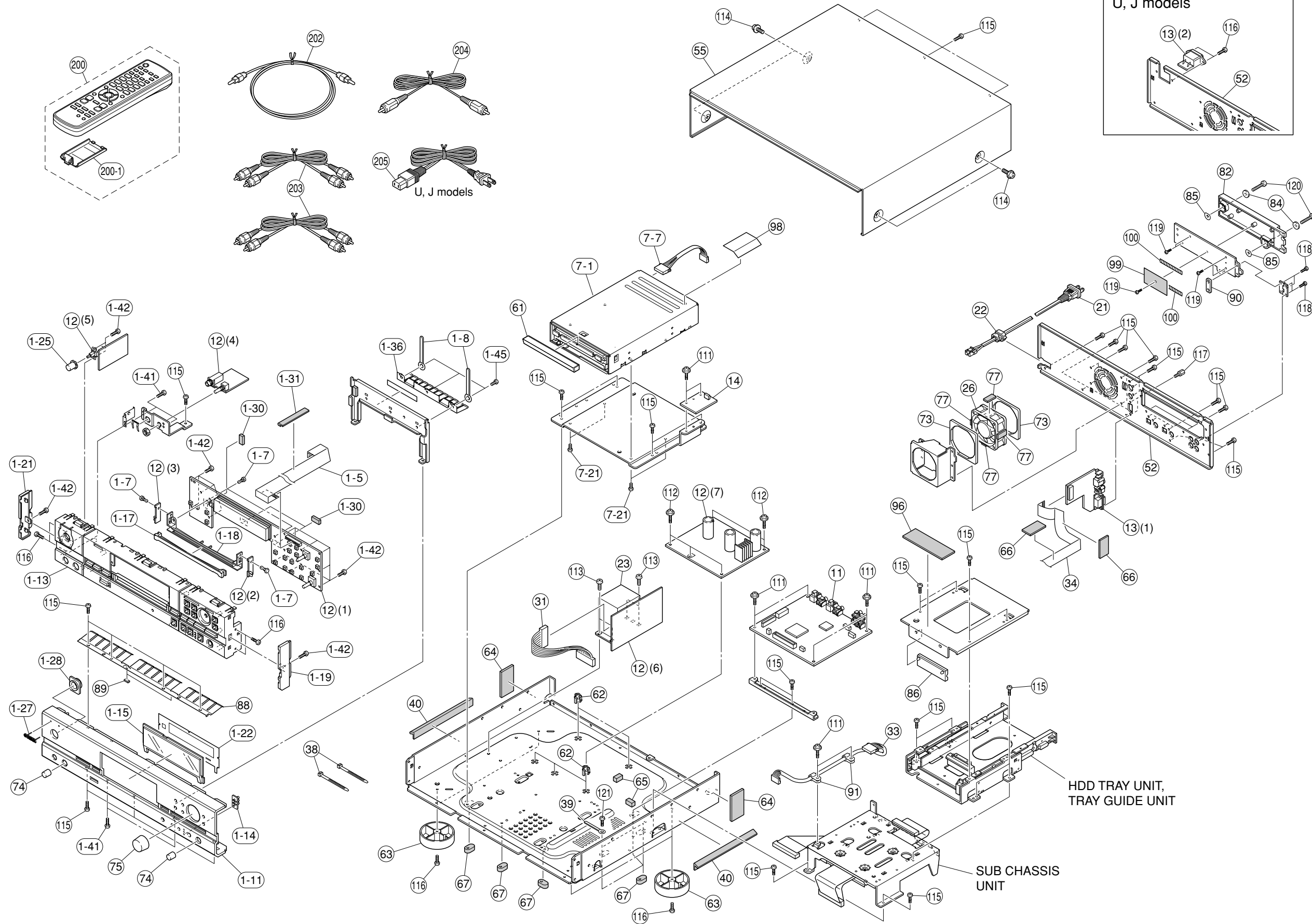

HDD TRAY UNIT, TRAY GUIDE UNIT

SUB CHASSIS UNIT

MECHANICAL PARTS

Ref. No.	Part No.	Description	Remarks	Markets	部品名	Rank
1-5	WB128100	FLEXIBLE FLAT CABLE			カード電線 C&C	04
1-7	V0368600	PUSH RIVET			ブッシュリベット	01
1-8	CB040540	BINDING TIE			束線止め	01
1-11	WE743300	FRONT PANEL	GD		フロントパネル	
1-11	WE743200	FRONT PANEL	BL		フロントパネル	
1-11	WE743400	FRONT PANEL	TI		フロントパネル	
1-13	WE743000	SUB PANEL	GD		サブパネル	
1-13	WE742900	SUB PANEL	BL		サブパネル	
1-13	WE743100	SUB PANEL	TI		サブパネル	
1-14	V6741300	LENS, LED			レンズ	
1-15	WE742200	WINDOW PANEL, LID			ウインドウ	
1-17	V7359800	REFLECTOR		PS	リフレクタ	
1-18	V7416900	REFLECTOR/CASE			レフレクタ/ケース	
1-19	V7416300	PLATE SIDE/R	GD		プレートサイド/R	03
1-19	V7416200	PLATE SIDE/R	BL		プレートサイド/R	
1-19	WE745100	PLATE SIDE/R	TI		プレートサイド/R	
1-21	V7416600	PLATE SIDE/L	GD		プレートサイド/L	03
1-21	V7416500	PLATE SIDE/L	BL		プレートサイド/L	
1-21	WE745200	PLATE SIDE/L	TI		プレートサイド/L	
1-22	WE742800	SHEET/DIFFUSION			シートデヒュージョン	
1-25	V5914600	BUTTON/D12	POWER	GD	ボタン/D12	02
1-25	V5914500	BUTTON/D12	POWER	BL	ボタン/D12	02
1-25	V9313600	BUTTON/D12	POWER	TI	ボタン/D12	
1-27	V6034200	EMBLEM		GD	エンブレム	03
1-27	V6034100	EMBLEM		BL, TI	エンブレム	03
1-28	V6094900	ESCUTCHEON/PW		GD	エスカッション/PW	01
1-28	V6094800	ESCUTCHEON/PW		BL	エスカッション/PW	
1-28	V9339500	ESCUTCHEON/PW		TI	エスカッション/PW	
1-30	V8080300	DAMPER FP			ダンパー/FP	
1-31	WA143800	DAMPER/OSD			ダンパー/OSD	01
1-36	V8146700	EARTH PLATE/CENTER			アースプレート	03
1-41	VN413300	BIND HEAD BONDING B-T. SCREW	3x8	MFZN2BL	ボンディングBタイトネジ	01
1-42	EP630220	BIND HEAD P-TIGHT SCREW	3x8	MFZN2BL	バインドPタイトネジ	01
1-45	EP600410	BIND HEAD S-TIGHT SCREW	3x6	MFZN2Y	バインドSタイトネジ	01
7-1	WE785100	CD-R/RW DRIVE	PX-W5232TA/T0BPY		CD-R/RWドライブ	
7-7	V7790200	CONNECTOR ASS'Y	4P 70mm	C&C	コネクタ-ASSY	
7-21	V2500500	BIND HEAD S-TIGHT SCREW	3x5	MFZN2BL	バインドSタイトネジ	
11	WF002400	P.C.B. ASS'Y	MAIN		PCB メイン	
12	V9443700	P.C.B. ASS'Y	OPERATION		PCB オペレーション	26
13	V9443800	P.C.B. ASS'Y	OSD	J	PCB OSD	12
13	V9443900	P.C.B. ASS'Y	OSD	U	PCB OSD	
13	V9444000	P.C.B. ASS'Y	OSD	ABG	PCB OSD	
14	WE860700	P.C.B. ASS'Y	WCLK		PCB WCLK	
21	WC743700	POWER CABLE	2m	A	電源コード	
21	VV437300	POWER CABLE	2m	B	電源コード	08
21	V9293600	POWER CABLE	2m	G	電源コード	
22	V2438700	CORD STOPPER	10P1	ABG	コードストッパー	02
23	X3031A00	POWER TRANSFORMER		J	電源トランス	10
23	X3032A00	POWER TRANSFORMER		U	電源トランス	
23	X3033A00	POWER TRANSFORMER		A	電源トランス	
23	X3034A00	POWER TRANSFORMER		BG	電源トランス	
26	V7719700	DC FAN MOTOR	DC D06T-12TL07(EX)		DCファンモーター	09
31	V7790700	CONNECTOR ASS'Y	10P 250mm	C&C	コネクタ-ASSY	
33	V9589600	CONNECTOR ASS'Y	4P 300mm	C&C	コネクタ-ASSY	04
34	V9589700	FLEXIBLE FLAT CABLE	18P 230mm	P=1.25	カード電線 C&C	03
38	VU590000	BINDING TIE	CBTD001B		インシュロックタイ	01
39	CB040540	BINDING TIE	S-72B		束線止め	01
40	WB835400	SOFT SHIELD	82-122-74008	L=170	ソフトシールド	05
52	WE743500	REAR PANEL		J	リヤパネル	
52	WE743600	REAR PANEL		U	リヤパネル	
52	WE743700	REAR PANEL		A	リヤパネル	
52	WE743800	REAR PANEL		BG	リヤパネル	

* New Parts * 新規部品

Ref. No.	Part No.	Description	Remarks	Markets	部品名	Rank
55	V9857800	TOP COVER		GD	トップカバー	09
55	V7354300	TOP COVER		BL	トップカバー	
55	V9857700	TOP COVER		TI	トップカバー	
61	WE742500	LID ASS'Y			リッドASSY	
62	VR264400	SPACER	H8		スペーサー	01
63	V0049900	LEG	D60xH16	GD	レッグ	03
63	V0780300	LEG	D60xH16	BL, TI	レッグ	01
64	V8001500	DAMPER/SIDE			ダンパー/サイド	
65	V0390100	DAMPER	8x8x15		ダンパー	01
66	WA143800	DAMPER/OSD			ダンパー/OSD	01
67	V7993800	DAMPER/SCREW			ダンパー/スクリュウ	
73	V8080500	CUSHION FAN			クッション/FAN	
74	V6101200	KNOB HP	LEVEL	GD	ノブ HP	02
74	V6101000	KNOB HP	LEVEL	BL	ノブ HP	
74	V9865600	KNOB HP	LEVEL	TI	ノブ HP	
75	V7358000	KNOB D26	MULTI JOG	GD	ノブ/D26	02
75	V7357900	KNOB D26	MULTI JOG	BL	ノブ D26	
75	WE745300	KNOB D26	MULTI JOG	TI	ノブ D26	
77	V8080600	CUSHION 10X20			クッション/10X20	
82	V9661800	COVER/REAR		JABG	カバー/リア	
82	V9479100	COVER/REAR		U	カバー/リア	
84	V9478900	WASHER/REAR			ワッシャー/リア	
85	V9597300	WASHER/A			ワッシャー/A	01
86	V9569900	CUSHION/TRAY			クッション/トレイ	
88	V8146600	EARTH PLATE/TOP			アースプレート	04
89	V8458300	DAMPER/EARTH			ダンパー/EARTH	01
90	V9603200	CUSHION/REAR			クッション/REAR	
91	CB065520	NYLON CLAMP	NK-3N		ナイロンクランプ	01
96	V9959600	DAMPER/UP		G	ダンパー/UP	
98	WB343600	SHEET/F1A			シート/F1A	01
99	WE786000	SHEET/COVER			シート/カバー	
100	WC021000	SHIELD FINGERS	H-100-00		シールドフィンガー	03
111	VT669300	PW HEAD B-TIGHT SCREW	3x8-8	MFC2	PWヘッドBタイトネジ	01
112	VT669400	PW HEAD B-TIGHT SCREW	3x15-8	MFC2	PWヘッドBタイトネジ	01
113	V2728500	BIND HEAD S-TIGHT SCREW	4x7	MFZN2BL	バインドSタイトネジ	01
114	V0069600	PW HEAD S-TIGHT SCREW	4x8-10	MFN133	PWヘッドSタイトネジ	01
114	21991500	PW HEAD S-TIGHT SCREW	4x8-10	MFC2BL	PWヘッドSタイトネジ	01
115	VN413300	BIND HEAD BONDING B-T. SCREW	3x8	MFZN2BL	ボンディングBタイトネジ	01
116	EP600250	BIND HEAD B-TIGHT SCREW	3x8	MFZN2Y	バインドBタイトネジ	01
117	V6509600	JACK SCREW	SS6-A47511848		ジャックスクリュウ	01
118	V6534900	BIND HEAD S-TIGHT SCREW	2.6x5	MFZN2BL	バインドSタイト	
119	V6863900	BIND HEAD TAPPING SCREW	2.6x6	MFZN2BL	バインドTPネジ	
120	VH610100	BIND HEAD SCREW	3x14	MFZN2BL	バインド小ネジ	01
121	EP600410	BIND HEAD S-TIGHT SCREW	3x6	MFZN2Y	バインドSタイトネジ	01
200	WE885500	ACCESSORIES			付属品	
200-1	AAX57560	REMOTE CONTROL	CDR-5		リモコン	
202	V9156100	BATTERY COVER			電池蓋	04
203	VS381600	OPTICAL CABLE	1P CDL1711-1606G		光ケーブル	
203	VY952200	AUDIO PIN CABLE	2P 1.0m 1pc	J	ステレオピンケーブル	05
203	VY952200	AUDIO PIN CABLE	2P 1.0m 1pc	UABG	ステレオピンケーブル	04
204	V6508900	VIDEO PIN CABLE	1P 1.5m YE-YE 1pc		ビデオ用ピンケーブル	03
205	WA642300	POWER CABLE	2m 1pc	J	電源コード	07
205	V7704800	POWER CABLE	2m 1pc	U	電源コード	05
205	V7704800	BATTERIES	UM-3 2pcs		乾電池	
	WA045500	SERVICE TOOLS			IC書きこみ治具	21
	V9589500	IC WRITING BOARD WITH CABLE	40P 600mm P=2.0		フラットケーブル	06
	AAX39420	CONNECTOR, FLAT CABLE			サービス用HDDユニット	
		HDD UNIT FOR SERVICE				

* New Parts * 新規部品

■ HDD TRAY UNIT

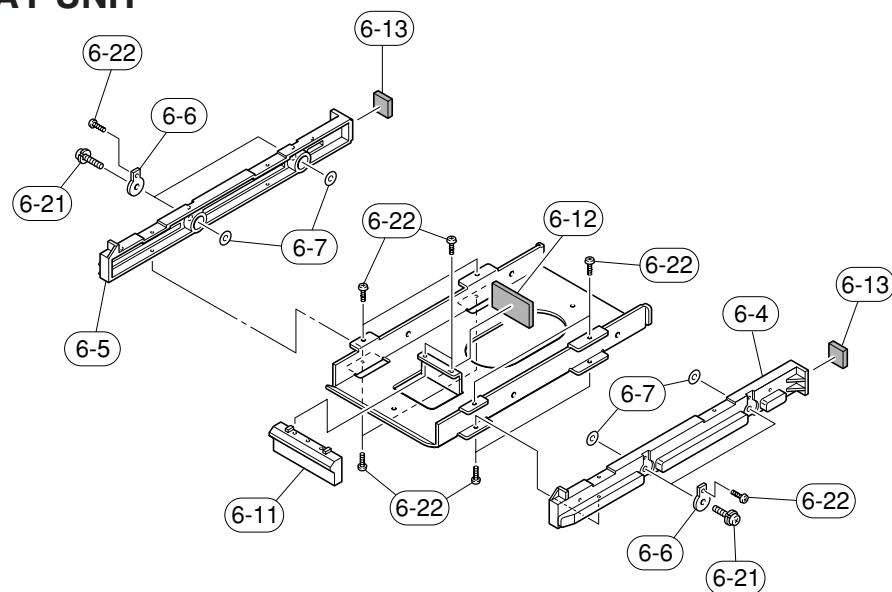

■ TRAY GUIDE UNIT

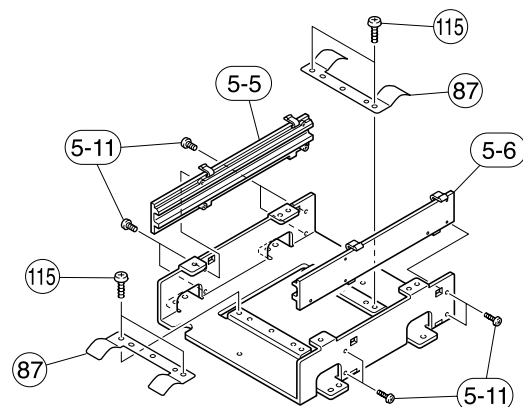

■ SUB CHASSIS UNIT

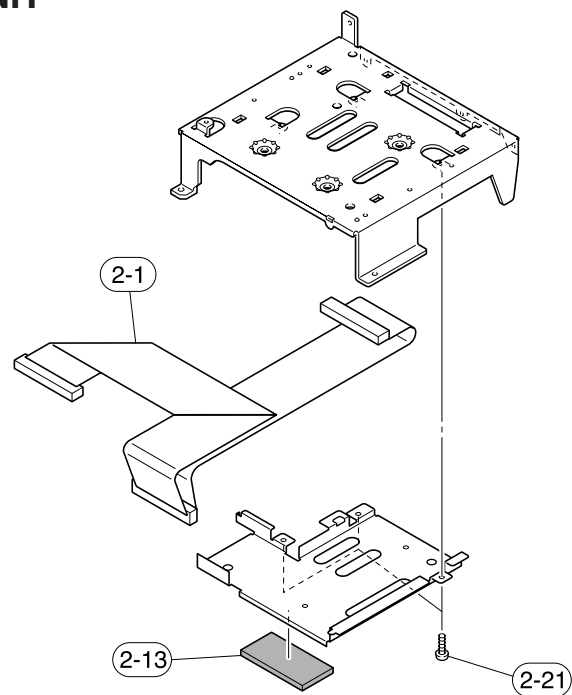

■ HDD TRAY UNIT

Ref. No.	Part No.	Description	Remarks	Markets	部品名	Rank
6-4	V9479200	FRAME SIDE/R			フレーム サイド/R	01
6-5	V9479300	FRAME SIDE/L			フレーム サイド/L	01
6-6	V9478800	WASHER/SIDE			ワッシャー/サイド	02
6-7	V9597400	WASHER/B			ワッシャー/B	01
6-11	V9569400	STOPPER			ストッパー/トレイ	
6-12	V9597500	DAMPER/BASE			ダンパー/BASE	
* 6-13	WF579100	DAMPER/SORVO			ダンパー/SORVO	
6-21	V9597800	PAN HEAD SCREW	6x32	MFZN2BL	十ナベ小ネジ	01
6-22	VG893800	BIND HEAD P-TIGHT SCREW	2x6	MFZN2BL	バインドPタイトネジ	01

* New Parts * 新規部品

■ TRAY GUIDE UNIT

Ref. No.	Part No.	Description	Remarks	Markets	部品名	Rank
5-5	V9479400	SUPPORT SIDE/R			サポート サイド/R	01
5-6	V9479500	SUPPORT SIDE/L			サポート サイド/L	01
5-11	VG893800	BIND HEAD P-TIGHT SCREW	2x6	MFZN2BL	バインドPタイトネジ	01
87	V9479000	EARTH PLATE			アースプレート	
115	VN413300	BIND HEAD BONDING B-T. SCREW	3x8	MFZN2BL	ボンディングBタイトネジ	01

* New Parts * 新規部品

■ SUB CHASSIS UNIT

Ref. No.	Part No.	Description	Remarks	Markets	部品名	Rank
2-1	V9589500	CONNECTOR, FLAT CABLE	40P 600mm P=2.0		フラットケーブル	06
2-13	V9597600	DAMPER/FFC			ダンパー/FFC	
2-21	VN413300	BIND HEAD BONDING B-T. SCREW	3x8	MFZN2BL	ボンディングBタイトネジ	01

* New Parts * 新規部品

■ REMOTE CONTROL

SCHEMATIC DIAGRAM

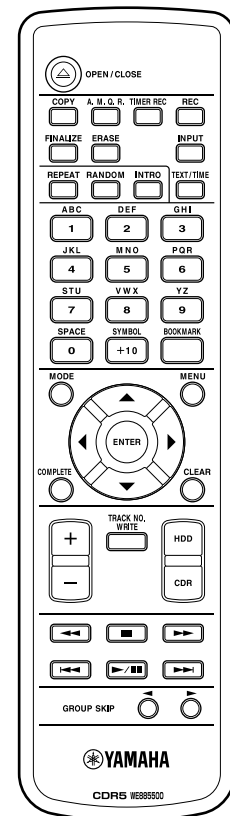
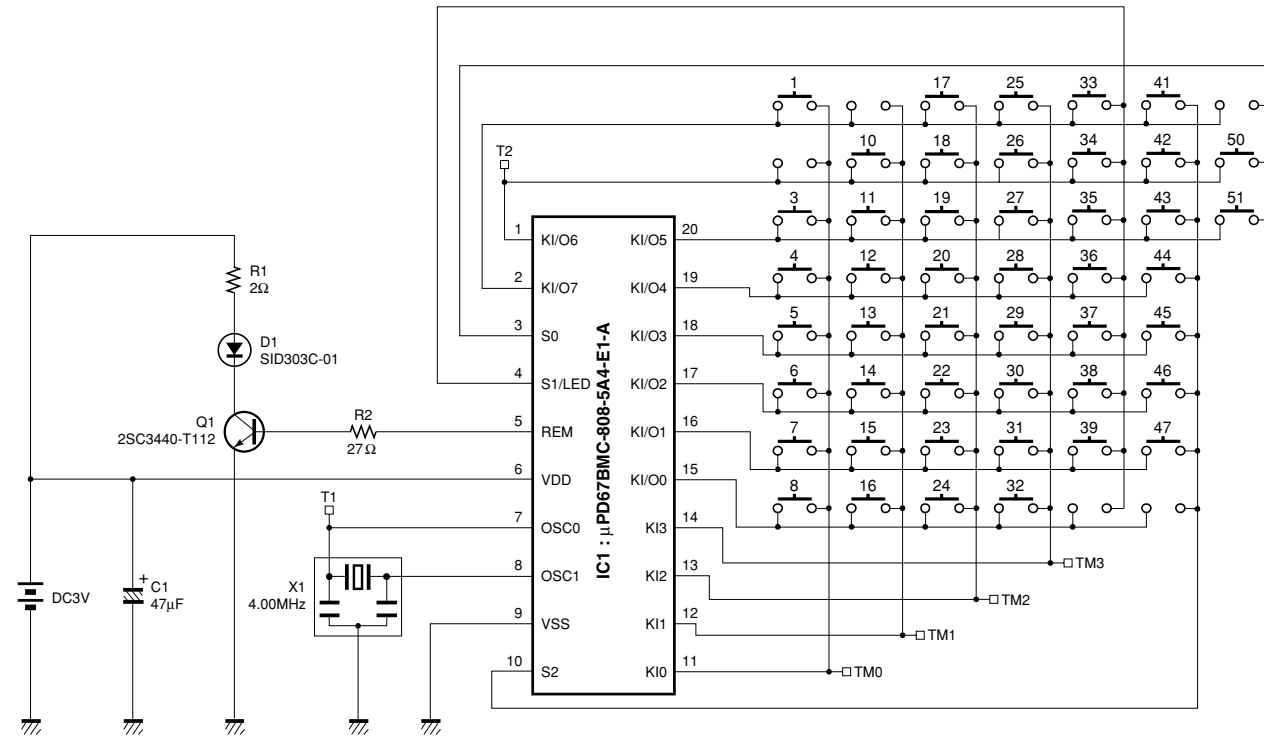

Key No.	Key Name	Custom Code (HEX)	Data Code (HEX)	Key No.	Key Name	Custom Code (HEX)	Data Code (HEX)
1	OPEN/CLOSE	7F-80	81	27	MODE	7F-80	B9
2	(Reserved)	7F-80	80	28	▲	7F-80	D9
3	COPY	7F-80	A3	29	MENU	7F-80	BA
4	A.M.Q.R.	7F-80	A8	30	◀	7F-80	D7
5	TIMER REC	7F-80	B6	31	ENTER	7F-80	B7
6	REC	7F-80	A0	32	▶	7F-80	D6
7	FINALIZE	7F-80	A5	33	COMPLETE	7F-80	B8
8	ERASE	7F-80	A6	34	▼	7F-80	D8
9	(Reserved)	7F-80	9C	35	CLEAR	7F-80	8C
10	INPUT	7F-80	AB	36	+	7F-80	BB
11	REPEAT	7F-80	8D	37	TRACK NO. WRITE	7F-80	A7
12	RANDOM	7F-80	8E	38	HDD	7F-80	BE
13	INTRO	7F-80	8F	39	-	7F-80	BC
14	TEXT/TIME	7F-80	9E	40	(Reserved)	7F-80	A1
15	1	7F-80	91	41	CDR	7F-80	BD
16	2	7F-80	92	42	◀◀	7F-80	88
17	3	7F-80	93	43	■	7F-80	84
18	4	7F-80	94	44	▶▶	7F-80	89
19	5	7F-80	95	45	◀◀	7F-80	86
20	6	7F-80	96	46	▶/■	7F-80	83
21	7	7F-80	97	47	▶▶	7F-80	87
22	8	7F-80	98	48	(Reserved)	7F-80	FD
23	9	7F-80	99	49	(Reserved)	7F-80	9F
24	0	7F-80	90	50	GROUP SKIP ◀	7F-80	DE
25	+10	7F-80	9A	51	GROUP SKIP ▶	7F-80	DF
26	BOOKMARK	7F-80	DD				

Parts List for Carbon Resistors

Value	1/4W Type Part No.	1/6W Type Part No.	Value	1/4W Type Part No.	1/6W Type Part No.
1.0 Ω	HJ35 3100	HF85 3100	10 kΩ	HF45 7100	HF45 7100
1.8 Ω	HJ35 3180	*	11 kΩ	HF45 7110	HF45 7110
2.2 Ω	HJ35 3220	HF85 3220	12 kΩ	HJ35 7120	HF85 7120
3.3 Ω	HJ35 3330	HF85 3330	13 kΩ	HF45 7130	HF45 7130
4.7 Ω	HJ35 3470	HF85 3470	15 kΩ	HF45 7150	HF45 7150
5.6 Ω	HJ35 3560	HF85 3560	18 kΩ	HF45 7180	HF45 7180
10 Ω	HF45 4100	HF45 4100	22 kΩ	HF45 7220	HF45 7220
15 Ω	HJ35 4150	HF85 4150	24 kΩ	HF45 7240	HF45 7240
22 Ω	HF45 4220	HF45 4220	27 kΩ	HJ35 7270	HF85 7270
27 Ω	HJ35 4270	HF85 4270	30 kΩ	HF45 7300	HF45 7300
33 Ω	HF45 4330	HF45 4330	33 kΩ	HF45 7330	HF45 7330
39 Ω	HJ35 4470	HF85 4390	36 kΩ	HF45 7360	HF45 7360
47 Ω	HF45 4470	HF45 4470	39 kΩ	HF45 7390	HF45 7390
56 Ω	HF45 4560	HF45 4560	47 kΩ	HF45 7470	HF45 7470
68 Ω	HF45 4680	HF45 4680	51 kΩ	HF45 7510	HF45 7510
75 Ω	HF45 4750	HF45 4750	56 kΩ	HF45 7560	HF45 7560
82 Ω	HF45 4820	HF45 4820	62 kΩ	HF45 7620	HF45 7620
91 Ω	HF45 4910	HF45 4910	68 kΩ	HF45 7680	HF45 7680
100 Ω	HF45 5100	HF45 5100	82 kΩ	HF45 7820	HF45 7820
110 Ω	HJ35 5110	HF85 5110	91 kΩ	HF45 7910	HF45 7910
120 Ω	HF45 5120	HF45 5120	100 kΩ	HF45 8100	HF45 8100
150 Ω	HF45 5150	HF45 5150	110 kΩ	HF45 8110	HF45 8110
160 Ω	HJ35 5160	*	120 kΩ	HF45 8120	HF45 8120
180 Ω	HF45 5180	HF45 5180	150 kΩ	HF45 8150	HF45 8150
200 Ω	HF45 5200	HF45 5200	180 kΩ	HF45 8180	HF45 8180
220 Ω	HF45 5220	HF45 5220	220 kΩ	HJ35 8220	HF85 8220
270 Ω	HF45 5270	HF45 5270	270 kΩ	HF45 8270	HF45 8270
330 Ω	HF45 5330	HF45 5330	300 kΩ	HF45 8300	HF45 8300
390 Ω	HF45 5390	HF45 5390	330 kΩ	HF45 8330	HF45 8330
430 Ω	HF45 5430	HF45 5430	390 kΩ	HJ35 8390	HF85 8390
470 Ω	HF45 5470	HF45 5470	470 kΩ	HF45 8470	HF45 8470
510 Ω	HF45 5510	HF45 5510	560 kΩ	HJ35 8560	HF85 8560
560 Ω	HF45 5560	HF45 5560	680 kΩ	HJ35 8680	HF85 8680
680 Ω	HF45 5680	HF45 5680	820 kΩ	HJ35 8820	HF85 8820
820 Ω	HF45 5820	HF45 5820	1.0 MΩ	HF45 9100	HF45 9100
910 Ω	HF45 5910	HF45 5910	1.2 MΩ	HJ35 9120	*
1.0 kΩ	HF45 6100	HF45 6100	1.5 MΩ	HJ35 9150	HF85 9150
1.2 kΩ	HF45 6120	HF45 6120	1.8 MΩ	HJ35 9180	HF85 9180
1.5 kΩ	HF45 6150	HF45 6150	2.2 MΩ	HJ35 9220	HF85 9220
1.8 kΩ	HF45 6180	HF45 6180	3.3 MΩ	HJ35 9330	HF85 9330
2.0 kΩ	HJ35 6200	HF85 6200	3.9 MΩ	HJ35 9390	*
2.2 kΩ	HF45 6220	HF45 6220	4.7 MΩ	HJ35 9470	HF85 9470
2.4 kΩ	HJ35 6240	HF85 6240			
2.7 kΩ	HF45 6270	HF45 6270			
3.0 kΩ	HF45 6300	HF45 6300			
3.3 kΩ	HF45 6330	HF45 6330			
3.6 kΩ	HJ35 6360	HF85 6360			
3.9 kΩ	HF45 6390	HF45 6390			
4.7 kΩ	HF45 6470	HF45 6470			
5.1 kΩ	HF45 6510	HF45 6510			
5.6 kΩ	HF45 6560	HF45 6560			
6.8 kΩ	HF45 6680	HF45 6680			
8.2 kΩ	HF45 6820	HF45 6820			
9.1 kΩ	HF45 6910	HF45 6910			

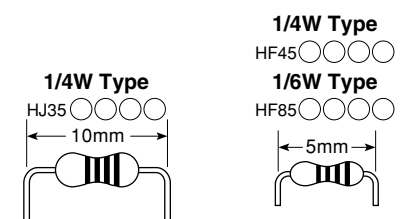

* : Not available

CDR-HD1500



Service News

Audio

YAMAHA CORPORATION P.O. BOX 1, HAMAMATSU, JAPAN

BULLETIN NO. **E-1042** 1/2

CDR-HD1500

DATE: July 2006

RELATED

BULLETIN NO.:

Introduction of Operation Checked HDD

PURPOSE: Following HDDs have been proved by YAMAHA for their compatibility with CDR-HD1500 as of June, 2006.

“Operation checked HDD” means HDDs that could replay without problem after formatting by YAMAHA spec and also ripping of specified disc (74 minutes CD for music).

400GB Class

Manufacturers	Series/Model No.	Capacity
MAXTOR	DiamondMax 11/6H400R0	400GB
Seagate	Barracuda 7200.8/ST3400832A	400GB
HGST*	Deskstar 7K400/HDS724040KLAT80	400GB

320GB Class

Manufacturers	Series/Model No.	Capacity
Western Digital	JB Series/WD3200JB	320GB

300GB Class

Manufacturers	Series/Model No.	Capacity
Seagate	Barracuda 7200.8/ST3300831A	300GB
MAXTOR	MaxLine II/5A300J0	300GB

250GB Class

Manufacturers	Series/Model No.	Capacity
Western Digital	JB Series/WD2500JB	250GB
Seagate	Barracuda 7200.8/ST3250823A	250GB
MAXTOR	MaxLine PlusII/7Y250P0	250GB
MAXTOR	DiamondMax 10/6L250R0	250GB
HGST*	Deskstar T7K250/HDT722525DLAT80	250GB
HGST*	Deskstar 7K250/HDS722525VLAT80	250GB
SAMSUNG	SpinPoint P120/SP2514N	250GB
SAMSUNG	SpinPoint V120/HA250JC	250GB

200GB Class

Manufacturers	Series/Model No.	Capacity
Seagate	Barracuda 7200.7 Plus/ST3200822A	200GB
MAXTOR	DiamondMax 10/6L200P0	200GB
MAXTOR	DiamondMax Plus 9/6Y200P0	200GB
SAMSUNG	SpinPoint P120/SP2014N	200GB

160GB Class

Manufacturers	Series/Model No.	Capacity
Seagate	Barracuda 7200.7/ST3160021A	160GB
Western Digital	JB Series/WD1600JB	160GB
HGST*	Deskstar T7K250/HDT722516DLAT80	160GB
SAMSUNG	SpinPoint P80/SP1604N	160GB
SAMSUNG	SpinPoint P80/SP1614N	160GB
MAXTOR	DiamondMax 10/6L160P0	160GB

120GB Class

Manufacturers	Series/Model No.	Capacity
Seagate	Barracuda 7200.7/ST3120022A	120GB

80GB Class

Manufacturers	Series/Model No.	Capacity
Seagate	Barracuda 7200.7/ST380011A	80GB

40GB Class

Manufacturers	Series/Model No.	Capacity
Seagate	Barracuda 5400.1/ST340015A	40GB

NOTES: HGST*: Hitachi Global Storage Technologies

See your local YAMAHA authorized dealer for additional information on HDDs.

Company names and product names referred in this instruction are trademarks of their respective companies.

Seagate's HDD "Barracuda 7200.9 series, Barracuda 7200.10 series" are confirmed their malfunction with CDR-HD1500 as of June, 2006.

Service News

Audio

YAMAHA CORPORATION P.O. BOX 1, HAMAMATSU, JAPAN

BULLETIN NO. **E-1064**

CDR-HD1500

DATE: August 2006

RELATED

BULLETIN NO.:

[Additional Parts Entries CDR drive for RoHS](#)

PURPOSE: The CDR drive is changed to “CDR drive Premium 2” due to RoHS (Restriction of Hazardous Substances) from June production. The new CDR drive is installed at a different place than the previous one. Therefore, the support’s part number is introduced as below (also, the new disc tray’s shape is different from the previous one).

Previous (WE785100)

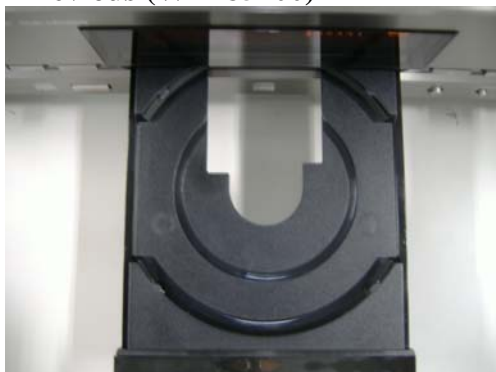

New (WG947900)

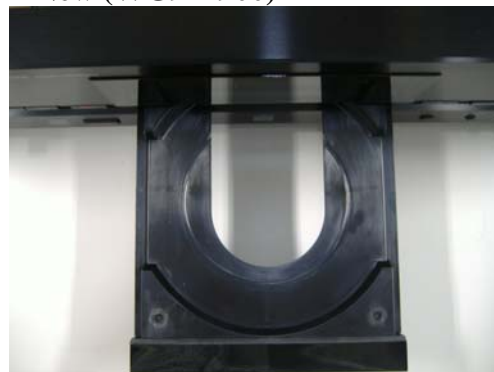

PART(S):

Ref. No.	Part No.	Description
7-1	WG947900	CD-R/RW DRIVE PREMIUM-2
7-11	WH160900	SUPPORT CDR
7-21	WF304200	BIND HEAD S-TIGHT SC 3X5 MFZN2B3

NOTE: The drive firmware version is different for the previous and new drives. When you install the new CD-R/RW drive “WG947900,” be sure to update the CD-R/RW drive firmware to the latest version, “[System: P2.0.00, CD-RW drive: CDRW 8.00.](#)”

When replacing the previous CD-R/RW drive “WE785100” PX-W5232TA, be sure the firmware is “[System: P1.040, CD-RW drive: CDRW 7.16.](#)”

APPLICABILITY: Below S/N Y123216SU.

Service News

Audio

YAMAHA CORPORATION P.O. BOX 1, HAMAMATSU, JAPAN

BULLETIN NO. **E-1169**

CDR-HD1500

DATE: November 2007

RELATED

BULLETIN NO.: E-1064

Firmware Updates

SYMPTOM: 1) For units with a RoHS compatible CDR mechanism (previously introduced in Service News E-1064, P/N WG947900) that will not burn data to CD-R/RW discs.
2) When burning data from the HDD to a CDR with Full Auto analog copy, instant audio cut-off occurs at approx. 12 seconds before the end of the music.

CAUSE: Microprocessor program error.

SOLUTION: Update the microprocessor firmware to the latest Version. Download the data file from the Yamaha AV Service Information System/ROM Update web site.

SERVICING: Update firmware to the latest version whenever one of these symptoms is reported.

NOTE: The drive firmware version for the previous drive differs from the new drive.
When installing a new CD-R/RW drive (P/N WG947900), be sure to update the CD-R/RW drive firmware to the latest version, “[System: P2.0.02, CD-RW drive: CDRW 8.10.](#)”
If installing a previous type CD-R/RW drive (PX-W5232TA, P/N WE785100), be sure the firmware is “[System: P1.0.42, CD-RW drive: CDRW 7.16.](#)”