

POWERED TD CONTROLLER

NXAMP4x1

SERVICE MANUAL

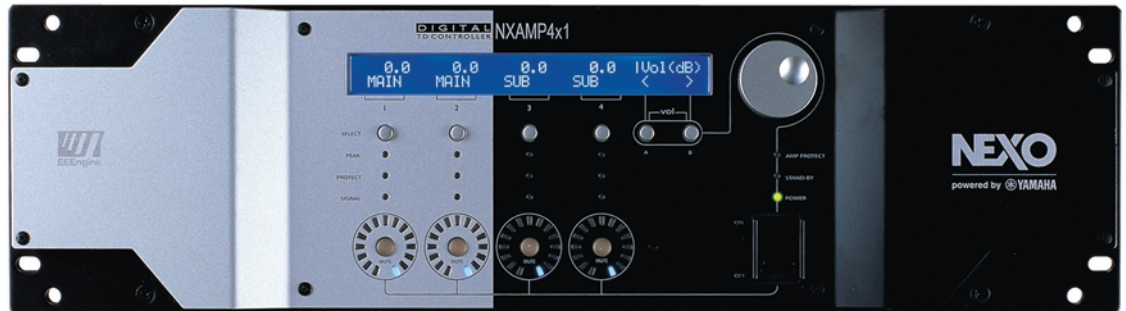

■ CONTENTS

PANEL LAYOUT	3
CIRCUIT BOARD LAYOUT	4
SERVICE PRECAUTIONS	5
OVERALL ASSEMBLY WIRING	7
DISASSEMBLY PROCEDURES	17
LSI PIN DESCRIPTION	26
IC BLOCK DIAGRAM	27
CIRCUIT BOARDS	33
TEST PROGRAM	52
INSPECTIONS	59
UPDATING THE FIRMWARE	64
PARTS LIST	
IC & DIODE FIGURES	
BLOCK DIAGRAM	
CIRCUIT DIAGRAM	

WARNING: This product contains chemicals known to the State of California to cause cancer, or birth defects or other reproductive harm.

DO NOT PLACE SOLDER, ELECTRICAL/ELECTRONIC OR PLASTIC COMPONENTS IN YOUR MOUTH FOR ANY REASON WHAT SO EVER!

Avoid prolonged, unprotected contact between solder and your skin! When soldering, do not inhale solder fumes or expose eyes to solder/flux vapor!

If you come in contact with solder or components located inside the enclosure of this product, wash your hands before handling food.

IMPORTANT NOTICE FOR THE UNITED KINGDOM

Connecting the Plug and Cord

WARNING: THIS APPARATUS MUST BE EARTHED

IMPORTANT. The wires in this mains lead are coloured in accordance with the following code:

GREEN-AND-YELLOW:	EARTH
BLUE:	NEUTRAL
BROWN:	LIVE

As the colours of the wires in the mains lead of this apparatus may not correspond with the coloured markings identifying the terminals in your plug, proceed as follows:

The wire which is coloured GREEN and YELLOW must be connected to the terminal in the plug which is marked by the letter E or by the safety earth symbol  or colored GREEN or colored GREEN and YELLOW.

The wire which is coloured BLUE must be connected to the terminal which is marked with the letter N or coloured BLACK.

The wire which is coloured BROWN must be connected to the terminal which is marked with the letter L or coloured RED.

■ WARNING

Components having special characteristics are marked  and must be replaced with parts having specification equal to those originally installed.

PANEL LAYOUT

• Front Panel

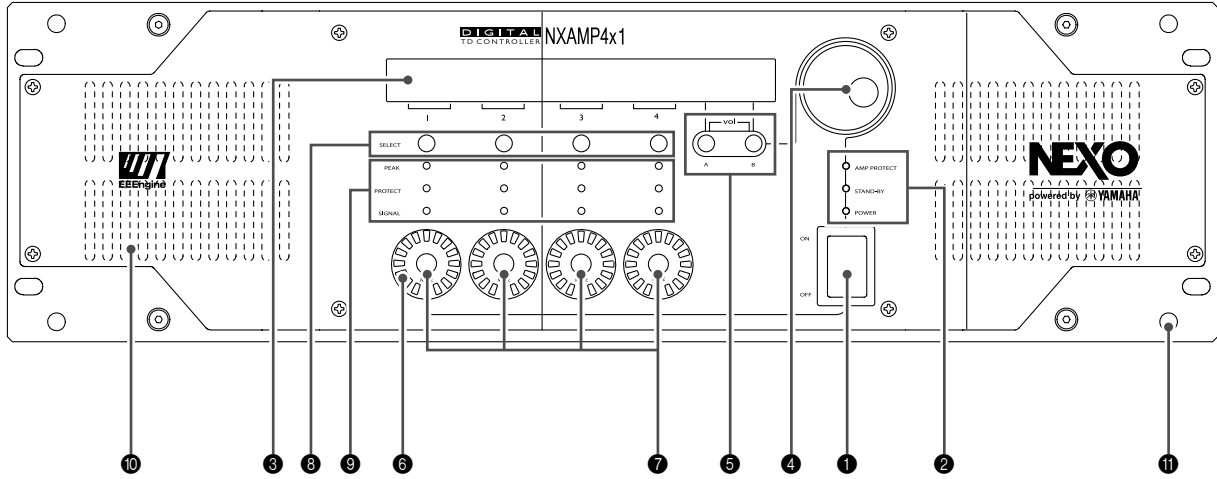

- | | |
|------------------------------|---------------------------|
| ① Power switch | ⑦ Mute buttons |
| ② Amplifier indicators | ⑧ Select buttons |
| ③ LCD display | ⑨ Channel indicators |
| ④ Encoder | ⑩ Air intakes |
| ⑤ Navigation buttons (A & B) | ⑪ Screw holes for handles |
| ⑥ Volume indicators | |

• Rear Panel

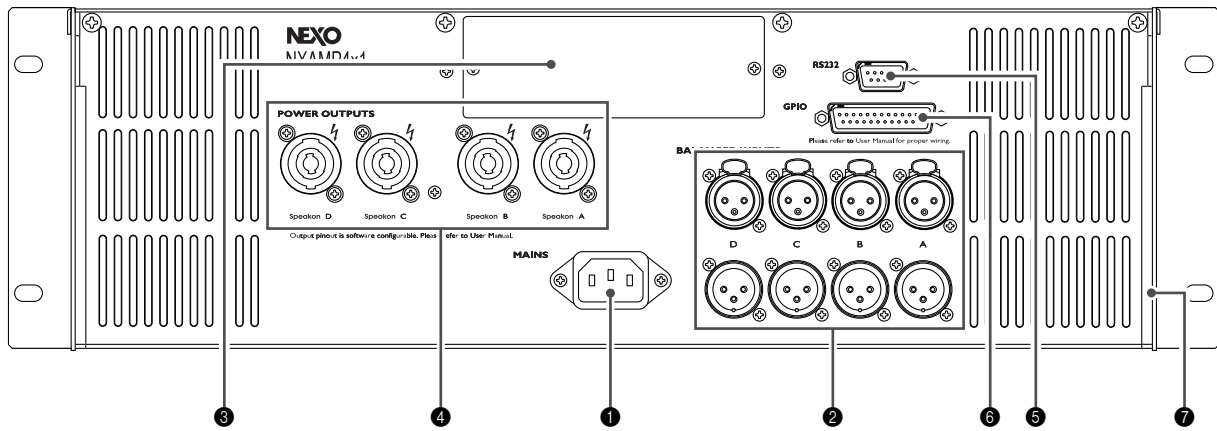

- | | |
|-----------------------------------|-------------------------------|
| ① Mains connectors | ⑤ RS-232 Firmware update port |
| ② Balanced audio inputs with link | ⑥ GPIO port |
| ③ Expansion slot | ⑦ Rear end mounting holes |
| ④ Power outputs | |

■ CIRCUIT BOARD LAYOUT

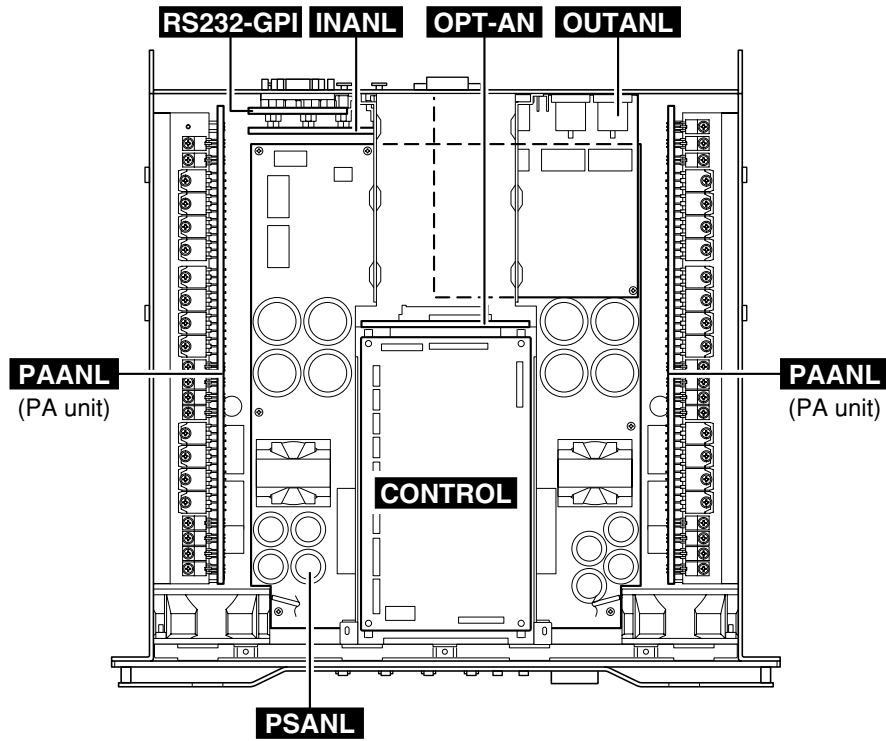

Rear Panel

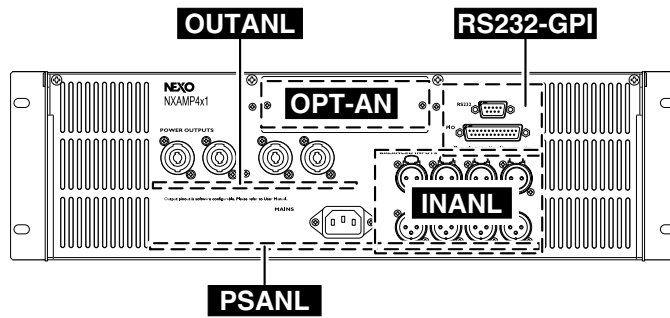

Front Panel

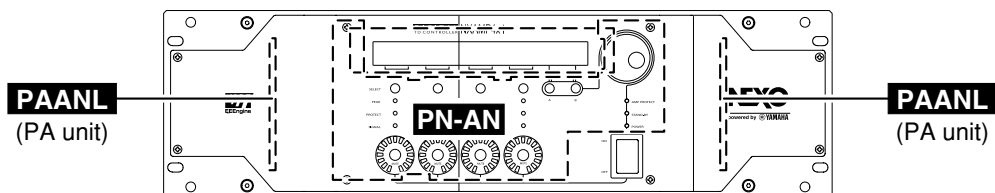

SERVICE PRECAUTIONS

Safety measures

- Some component parts on the PSANH circuit board maintain a high voltage even when the power is switched off. For this reason to avoid an electrical shock, do not touch the upper metallic part of the following capacitors until the remaining voltage has discharged.

[Discharging Method]

Before starting the service work, connect discharging resistors (220 ohms 10W) to the terminals indicated in the figure below to discharge electricity. (7 points)
The required discharging time is about 10 seconds. Check that the DC voltage between the terminals measures close to 0 (zero) volts using a multi-meter to make sure that the discharge is completed.

Note:

Do not touch the IC201 and its heat sink before discharging the C205.

Capacitors	Discharging point
C316, C317, C322, C323	① D305: + pin <=> D305: - pin
C318, C319, C324, C325	② D306: + pin <=> D306: - pin
C344, C354	③ CN305 <=> CN316
C345, C355	④ CN307 <=> CN316
C347, C356	⑤ CN308 <=> CN309
C348, C357	⑥ CN310 <=> CN309
C205	⑦ R213: lead <=> C201

PSANL circuit board

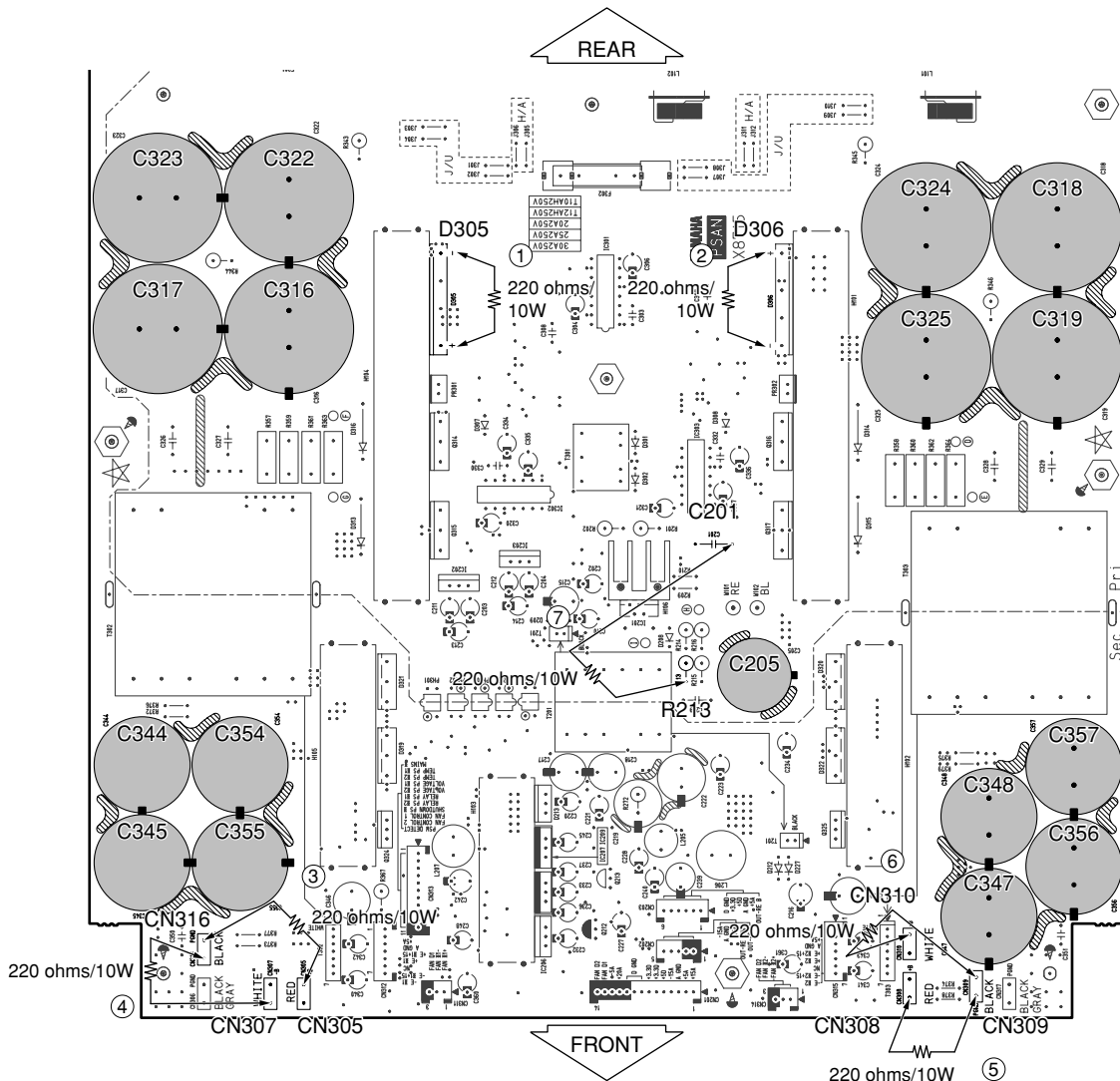

PSANL circuit diagram

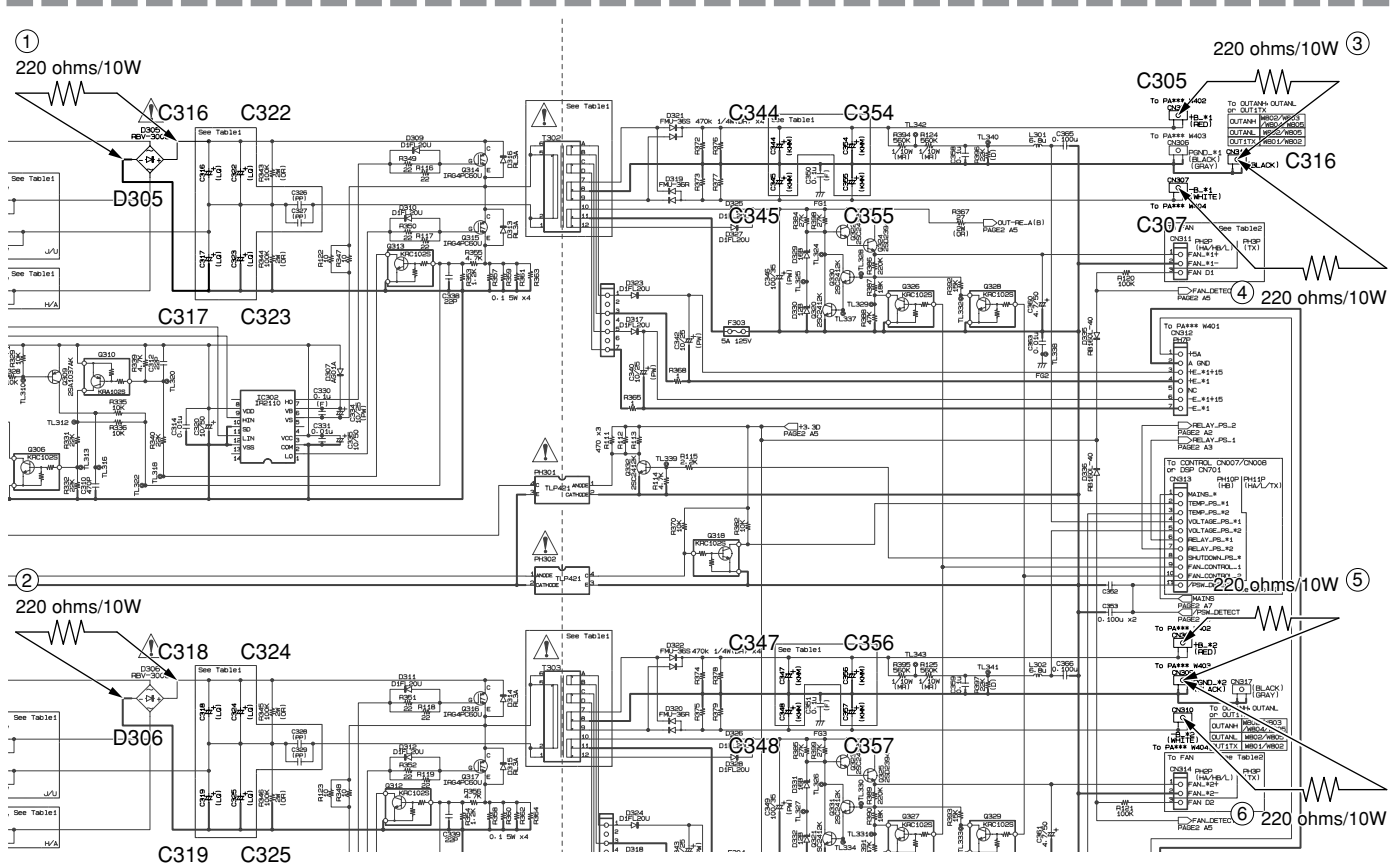
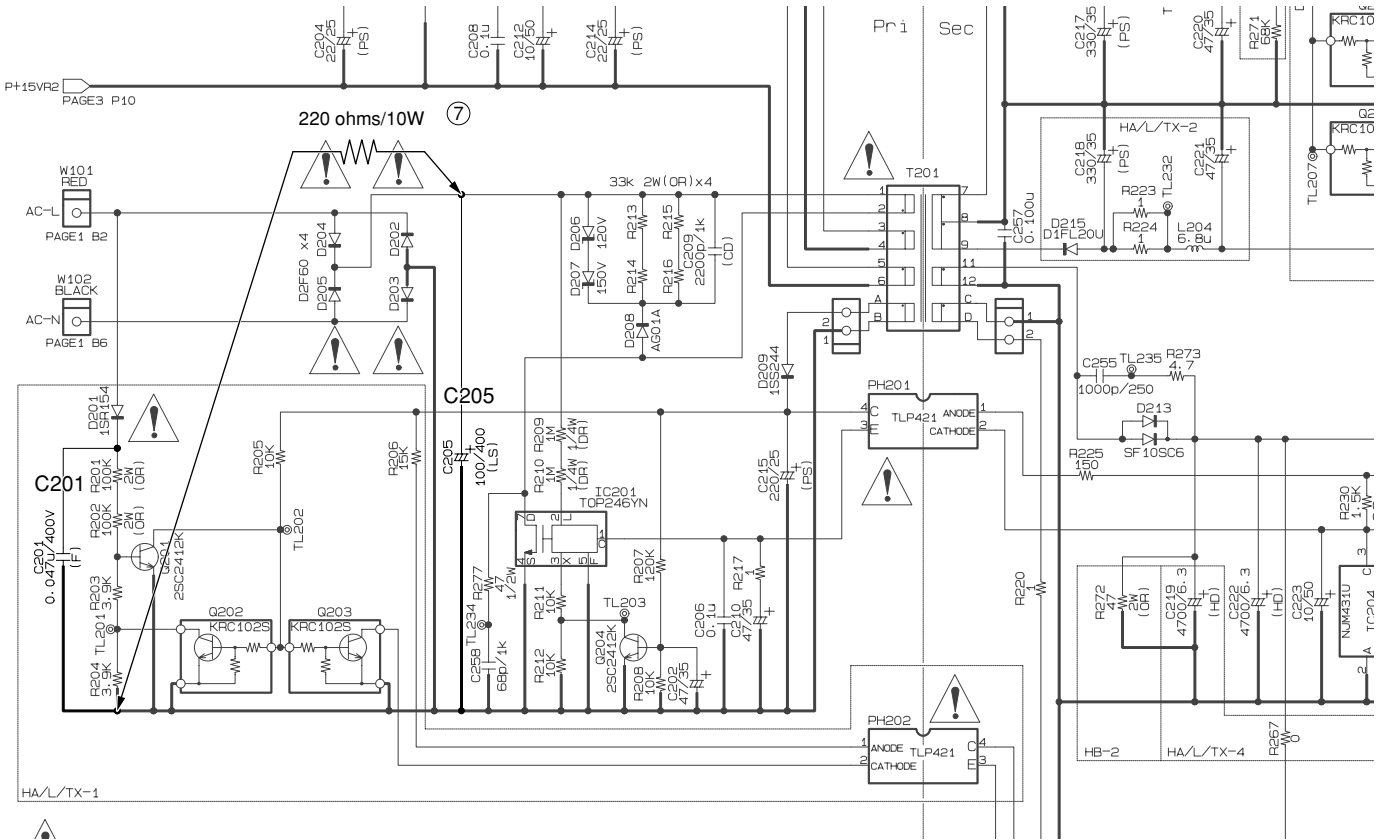

OVERALL ASSEMBLY WIRING

This product has various cables (wires and connector assemblies) inside. To prevent touching component to the cables and/or connection mistake, perform the cable connection and fixing cables according to the following instructions referring the wiring diagram, P3 of the circuit diagram.

Notice: Since the following pictures are taken of the preproduction product, they may differ from the commodity products in detail. However, the wiring and so on is not so differ between them. So, refer only to wiring and so on.

1. Wiring of the PN-AN circuit board

- 1) Process the flat cable (WK02100). (Fig. 1)
- 2) Connect the flat cable (WK02100) to the PN-AN circuit board. (Fig. 2)
- 3) Install the PN-AN circuit board to the front panel. (Fig. 3)

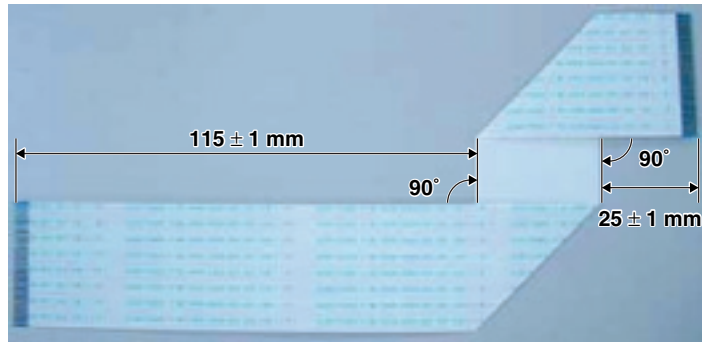

Fig. 1



Fig. 2



Fig. 3

2. Wiring of the power switch

- 1) Install the power switch to the front panel with its terminals set downward. (Fig. 4, 5)

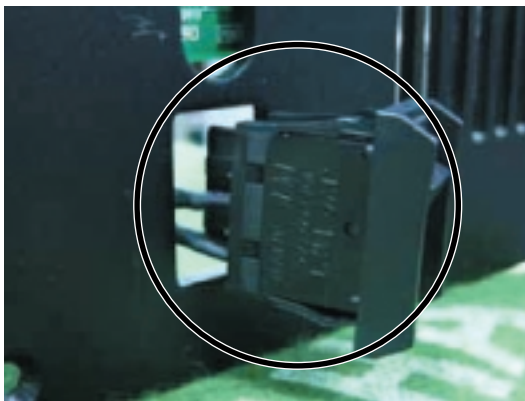

Fig. 4

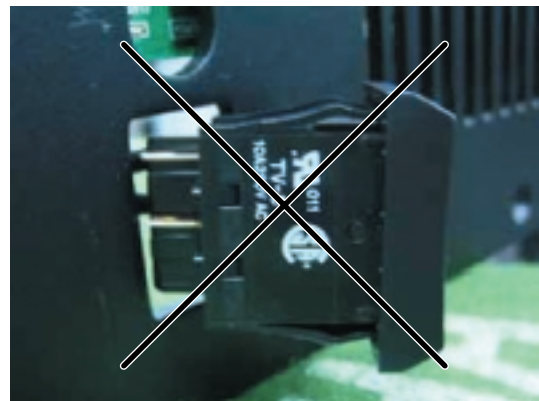

Fig. 5

- 2) Confirm that the power switch is set to the off position as shown in the figure 6. (Fig. 6)
- 3) Twist the wires of the power switch assembly more than three times.
- 4) Connect the connector of the power switch assembly to the connector (CN103). (Fig. 7)

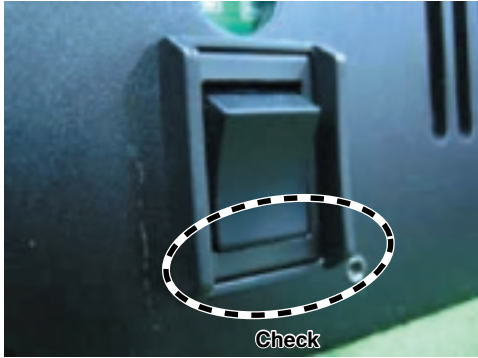

Fig. 6



Fig. 7

3. Wiring of the FAN

Connect the connector of the FAN to the each terminal. (Fig. 8)

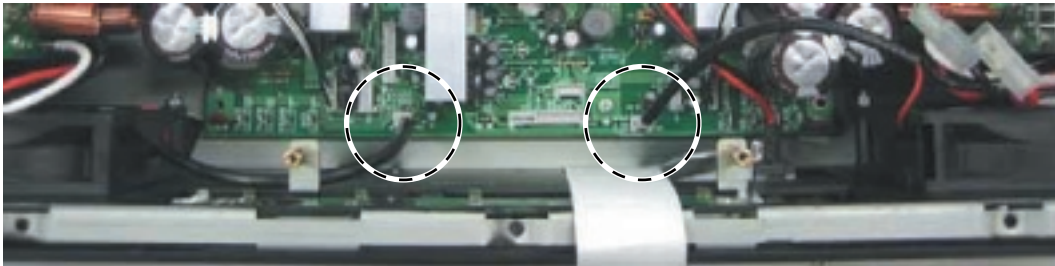

Fig. 8

4. Attaching of the support cushion

Attach the support cushion (WN15950) at the specified area on the pattern side of the CONTROL circuit board. (Fig. 9)

Note: Be sure to remove the oil and the dust, etc. on the attaching surface before attaching the support cushion.

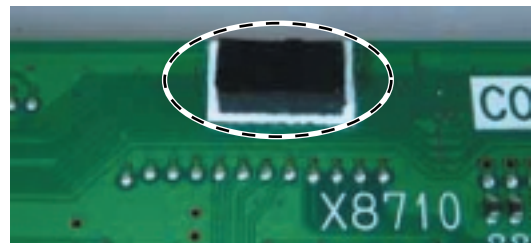

Fig. 9

5. Wiring of the AC-INLET

- a) Set a cord holder before installing the PSAN circuit board on the enclosure. (Fig. 10)



Fig. 10

- b) Set a ferrite-core at the specified area on the PSAN circuit board, and fasten the ferrite-core with the cord holder. (Fig. 11)

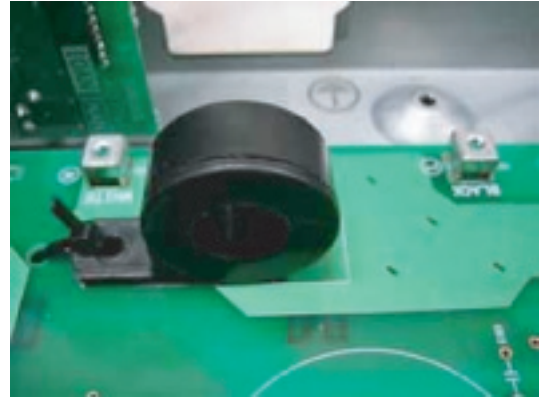

Fig. 11

- c) Pass the live and neutral wires of the AC-INLET through the ferrite core's hole twice and wind them to the ferrite core. Screw an each screw terminal to the specified terminal. (Fig. 12, 13)
 Fasten the GND wire with a cord holder. (U destination) (Fig. 12)
 Screwing torque: GND LINE 1.8N • m / L, N LINE 0.78 • m

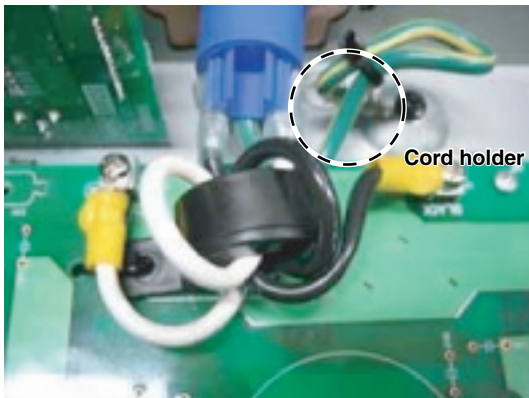

Fig. 12 (U.S.A. model)



Fig. 13 (Chinese model)

- d, e) Fix the wires to the terminal using the screws, and refer to the fig. 14 and fig. 15 for the direction of each terminal.



Fig. 14

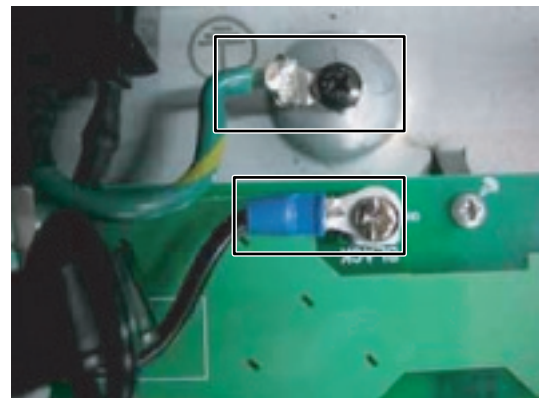

Fig. 15

6. Wiring of the PA-UNIT

Connect the wires to the connectors (CN401, CN403). (Fig. 16, 17)

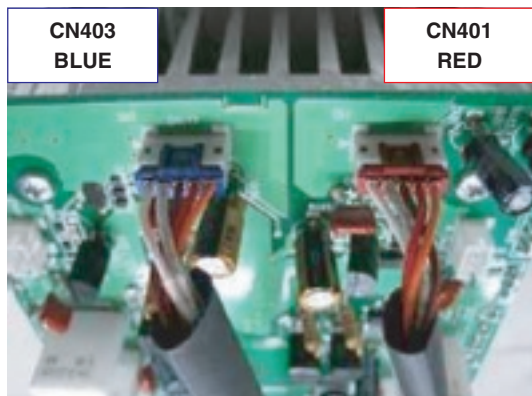

Fig. 16

NOTE: The followings are wires to be connected.

CN401: WK02080

CN403: WK90770

Install this PA-UNIT on the left side of enclosure.

Hereafter, this unit is called PA-UNIT of CH1, CH2.



Fig. 17

NOTE: The followings are wires to be connected.

CN401: WK90790

CN403: WK17110

Install this PA-UNIT on the right side of enclosure.

Hereafter, this unit is called PA-UNIT of CH3, CH4.

* The following figure describes a layout drawing of the PA-UNITs seen from the front panel. (Fig. 18)

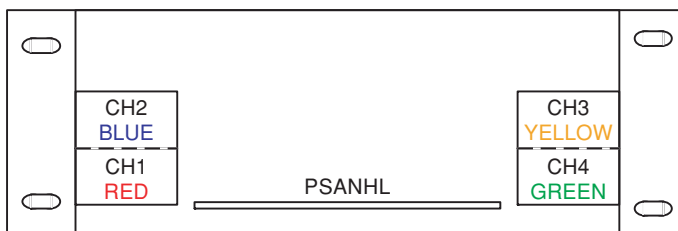

Fig. 18

7. Wiring of the flat cable and fastening wires

Connect the following wires at first.

CN313: WK68760

CN201: WK68770

- a) Install the RS232-GPI circuit board on the enclosure after connecting the wire (WM15830) to it.
- b) Connect the wires (WK16830, WN52530) from each PA UNIT to the FASTON terminals of the OUTANL circuit board.
 - PA-UNIT (CH1, CH2) : WN52530 (ORANGE) → CN805
 - WK16830 (YELLOW) → CN806
 - PA-UNIT (CH3, CH4) : WN52530 (ORANGE) → CN807
 - WK16830 (YELLOW) → CN808

Then fold the wires (WK16830, WF44430) at the center of them, and fasten them with a cord holder. (Fig. 19)

- c) Connect the wires (WK16820 x2) to the connectors (CN306, CN317) of the PSAN circuit board. Connect the wire (WK14200) to the connector (CN202) of the PSAN circuit board. Fasten these wires with a cord holder at the position as shown in the figure. (Fig. 19)
- d) Connect the wire (WK14210) of PA-UNIT (CH3, CH4) to the connector (CN315). Fasten the wire (WK14210) and the wires (WK16820 x2, WK14200) with a cord holder at the position where the wire (WK14210) is vertically pulled from PA-UNIT. Before fastening, pull the wires (WK16820 x2, WK14200) toward the front panel side in advance.

- e) Connect the wire (WK14210) of PA-UNIT (CH1, CH2) to the connector (CN312). Fasten the wire (WK14210) and the wire (WK02090) with a cord holder at the position where the wire (WK14210) is vertically pulled from PA-UNIT. Before fastening, pull the wire (WK02090) toward the front panel side in advance.
- f) Twist the wires (white, red and black) of PA-UNIT more than two times, and connect them to the FASTON terminals according to the wire color displayed on the PSANL circuit board. Then bend these wires, and fasten them with a cord holder. (Fig. 20)

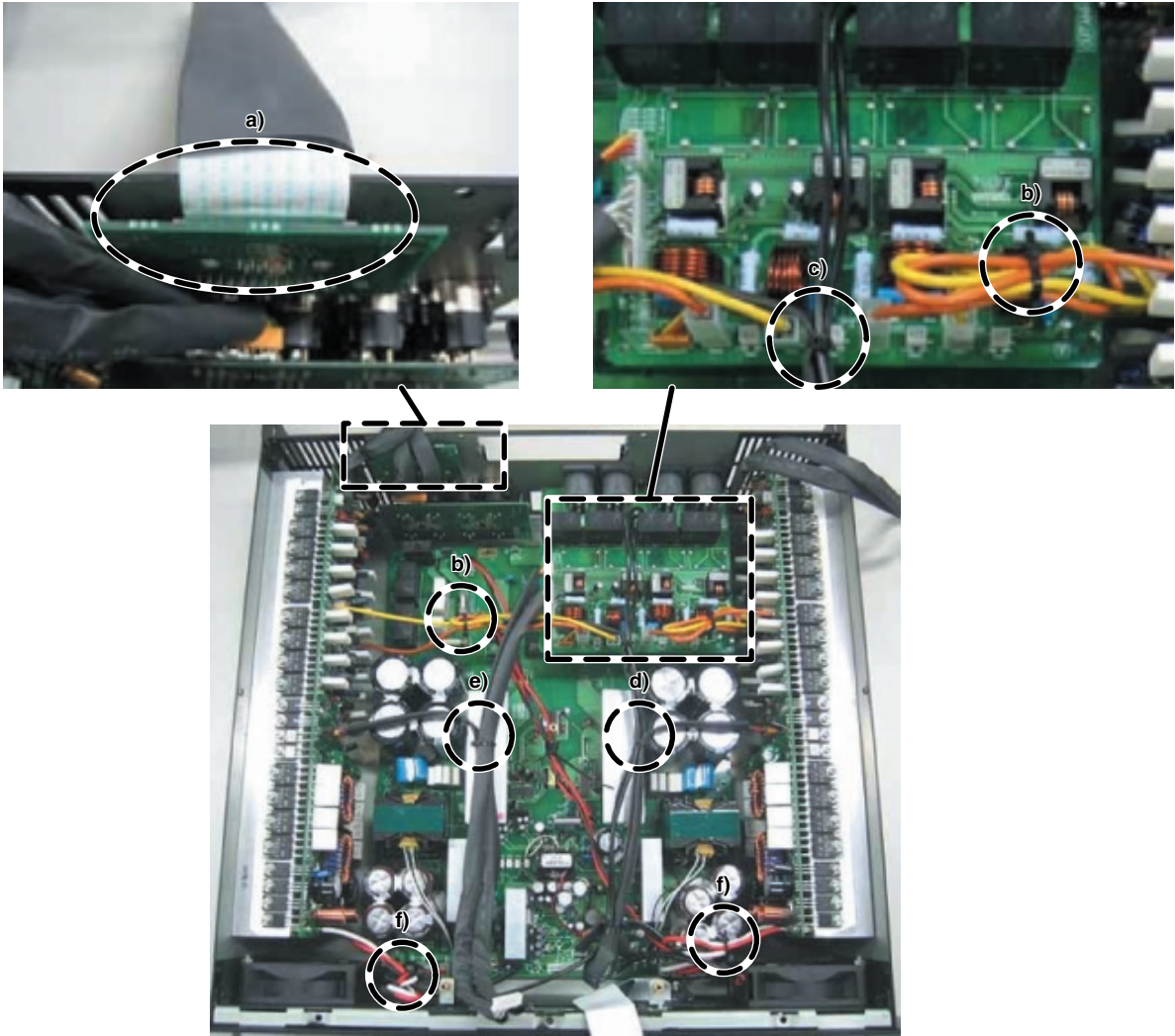

Fig. 19



Fig. 20

- g) Fasten these wires (WK17900, WK17910 and WK94710) with a cord holder to the hexagonal spacer. (Fig. 21)
- h) Bend the wire (WK14200) and wire (WK16820) connected to the connector (CN317), and fasten the wires (WK14210, WK16820 x 2 and WK14200) with a cord holder. (Fig. 21)

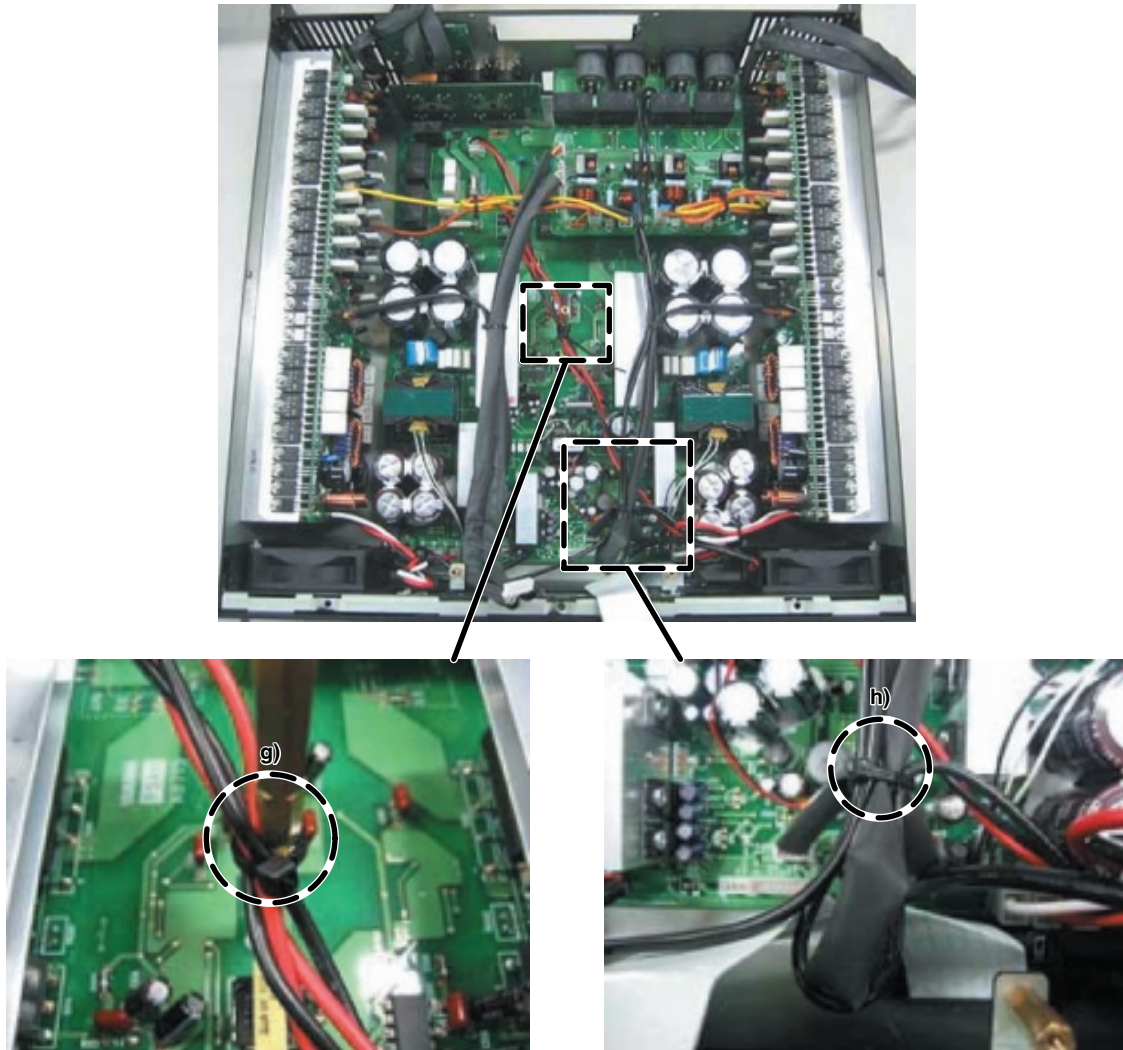

Fig. 21

Note: When connecting the connector assembly to the CONTROL circuit board, confirm that the connector housing pin number of the connector assembly is the same as the connector pin number of the circuit board.

- i) Fasten the wires (WK02080, WK90770) with a cord holder at the hole of the RS232-GPI circuit board. (Fig. 22)
- j) Fasten the wires (WK02080, WK90770 and WK02070) with a cord holder at the hole of the enclosure. Fasten the wires (WK90790, WK17110) with a cord holder at the hole of the enclosure. (Fig. 22)
- k) Fasten the wires (WK90790, WK17110) with a cord holder at the hole of the OPT-AN circuit board. Then connect the flat cable (WK02120). (Fig. 22)
- l) Fasten the wires (WK02080, WK90770, WK90790, WK17110 and WK02070) with a cord holder at the position close to the OPT-AN circuit board. (Fig. 22)
- m) Bend the wire (WK02090), and fasten the wires (WK02090, WK68760 and WK68770) with a cord holder. (Fig. 22).
- n) Bend the flat cable as shown in the figure. (Fig. 22)

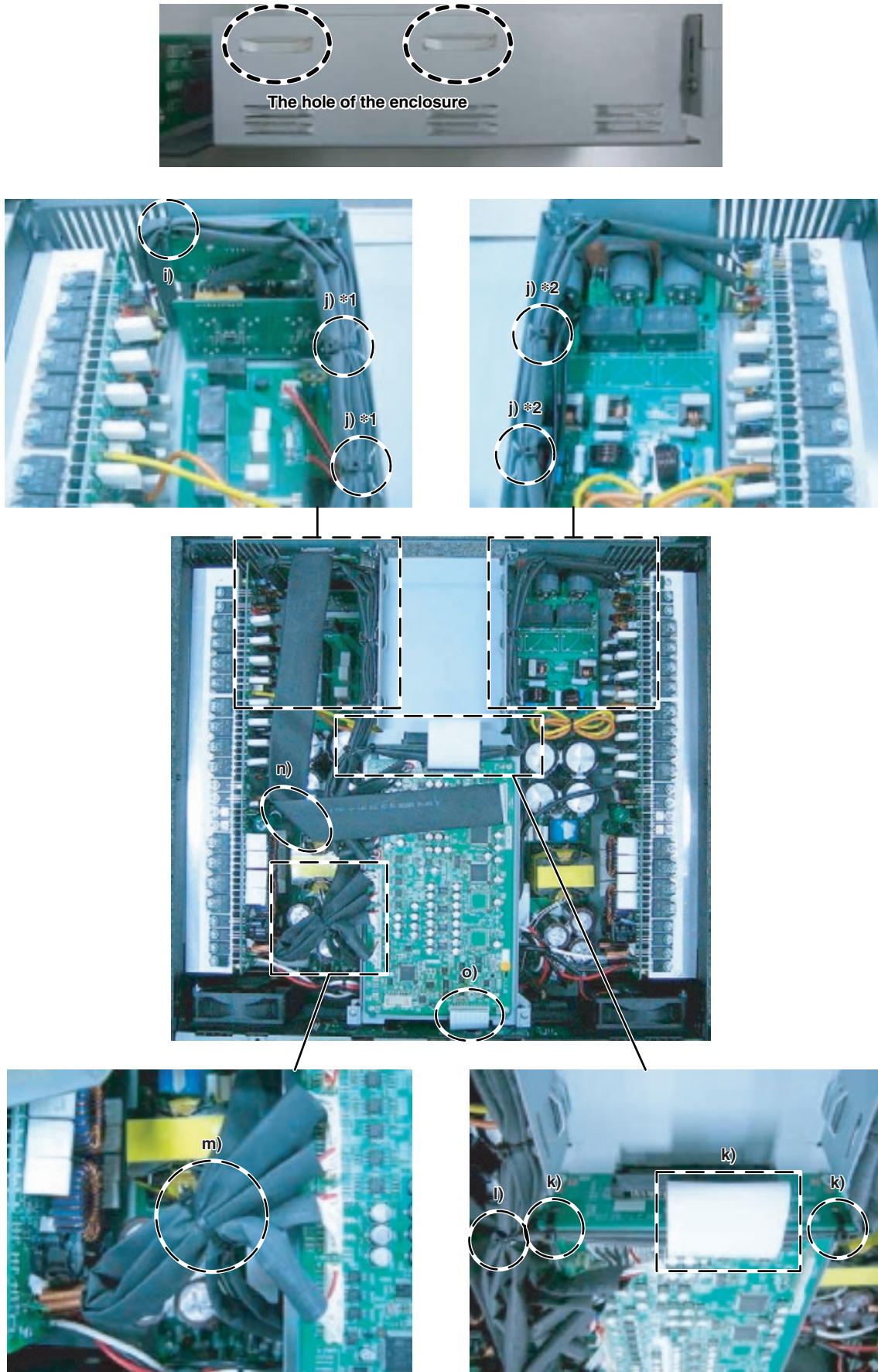

Fig. 22

- o) Bend the flat cable to avoid touching the top cover. (Fig. 23, 24)

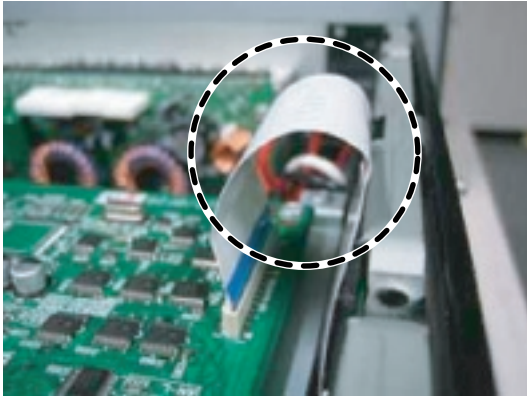

Fig. 23

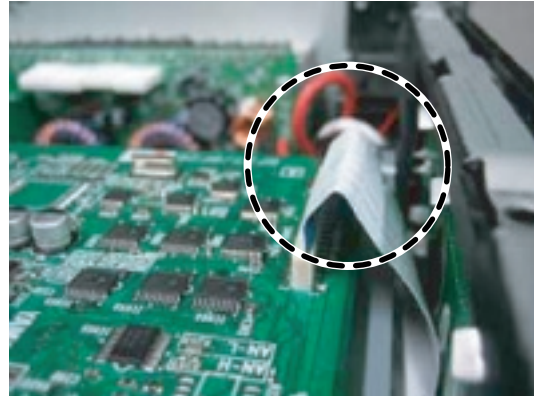

Fig. 24

8. Color of the connectors connected to the connector CN012-CN015

Connect the connector assembly from the PA unit to the CONTROL circuit board as shown in the figure below. (Fig. 25)

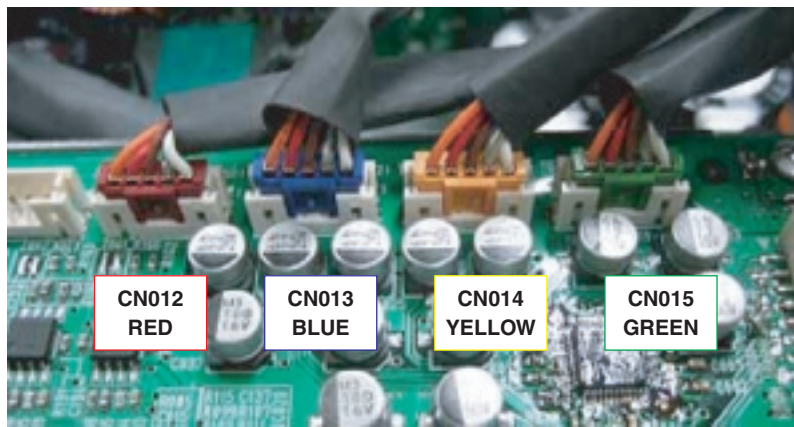

Fig. 25

9. Change of the destination

Set the knob position of the switch SW001 on the CONTROL circuit board as shown in the figure below. (Fig. 26, 27)

U destination

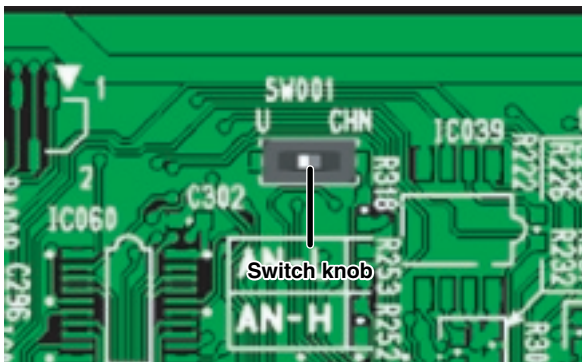

Fig. 26

CHN destination

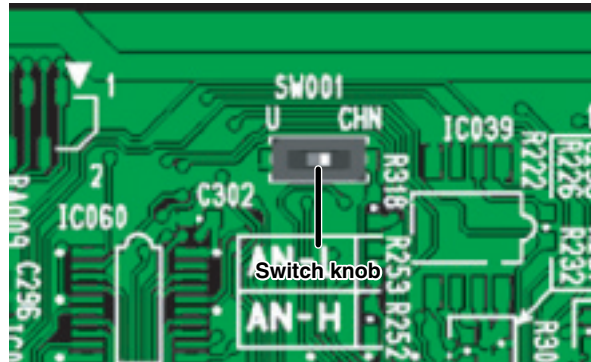

Fig. 27

10. Insulation distance between WK17110 and primary side capacitor

Perform wiring the connector assembly WK17110 with care so that its uncovered portion with the SUMI tube does not touch the capacitor C316 on primary side of the PSANL circuit board. (Fig. 28, 29)

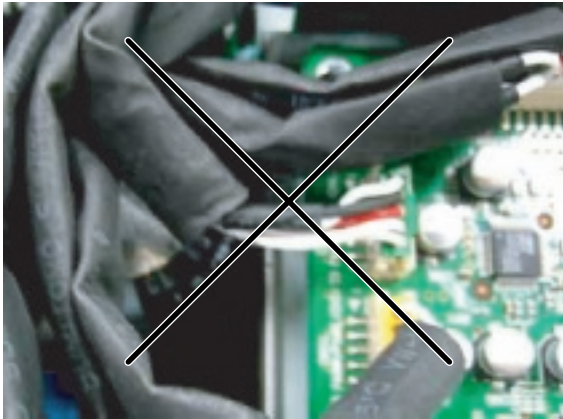

Fig. 28

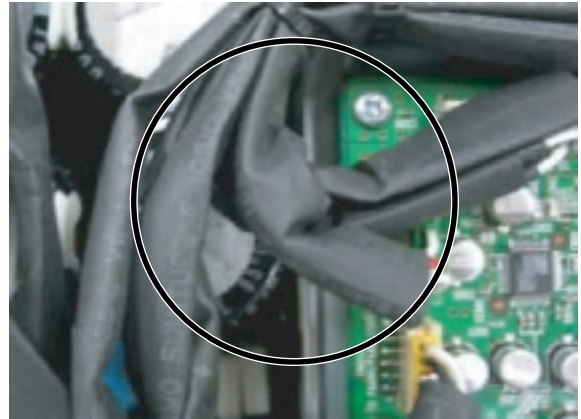

Fig. 29

11. Insulation distance between WK14210 and primary side capacitor

Perform wiring the connector assembly WK14210 with care so that its uncovered portion with the SUMI tube does not touch the capacitors C317 and C319 on primary side of the PSANL circuit board. (Fig. 30, 31)

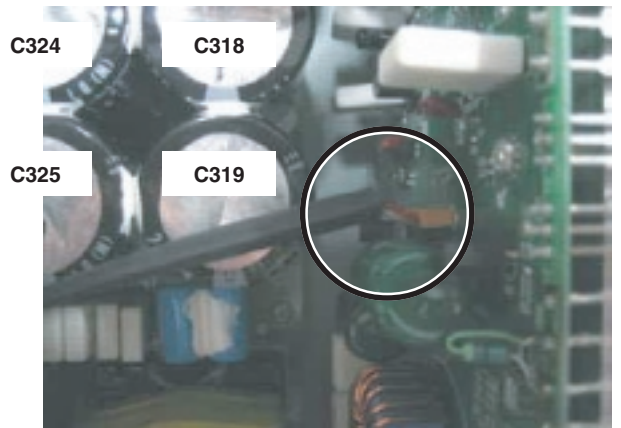
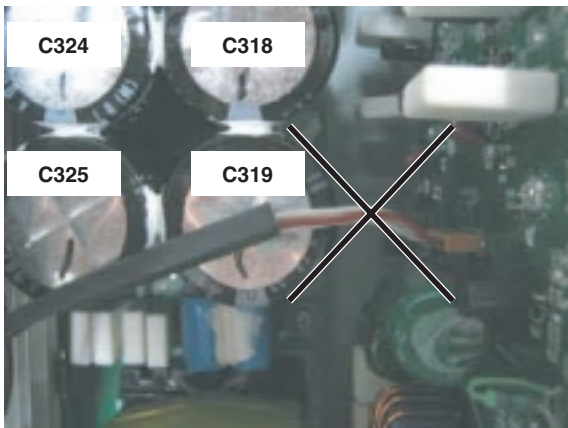

Fig. 30

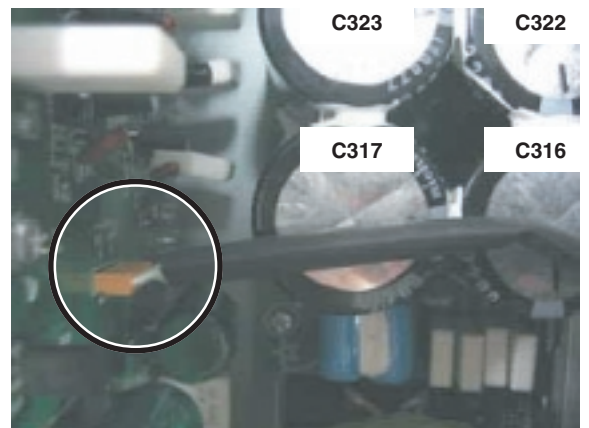
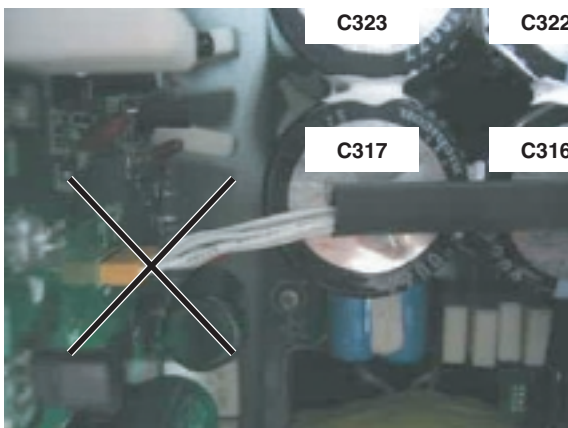

Fig. 31

12. Prevention of touching WK02070 to connector terminal

Perform wiring the connector assembly WK02070 with care so that its uncovered portion with the SUMI tube does not touch the bare terminal of the connector CN203 of the RS232-GPI circuit board. (Fig. 32)

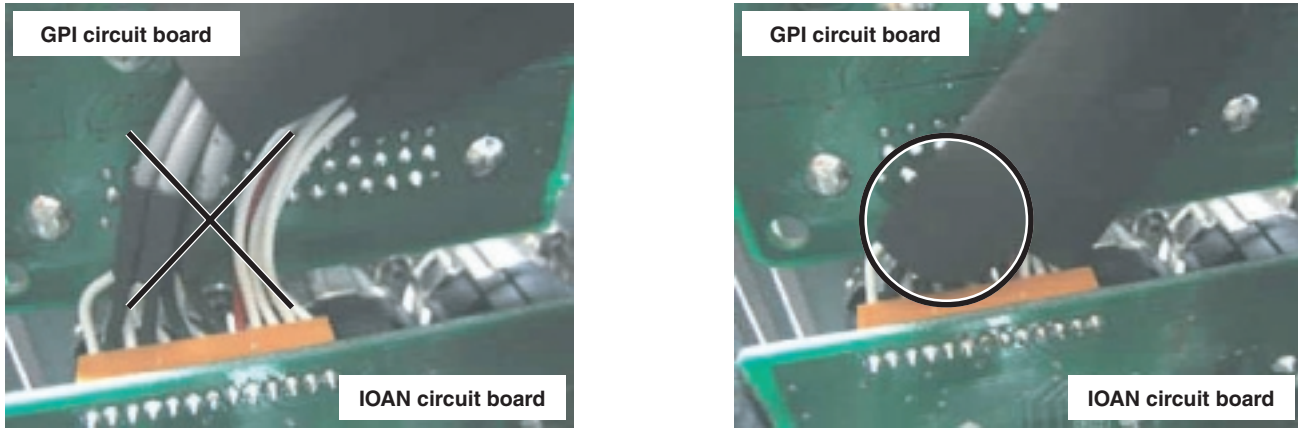

Fig. 32

13. Adhesive cloth tape

Cover the two screws near R587 and R588 in each PA unit (190 and 230) with adhesive cloth tape (185 and 225) as shown in the figure below. (Fig. 33)

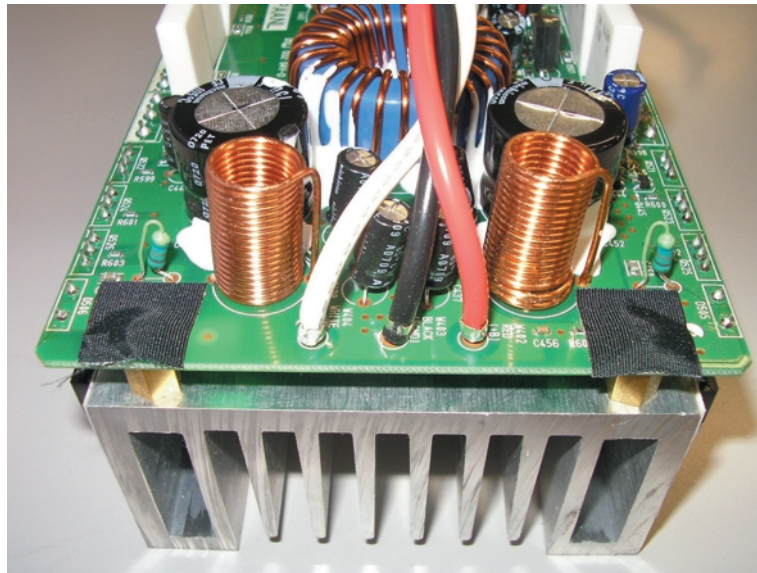
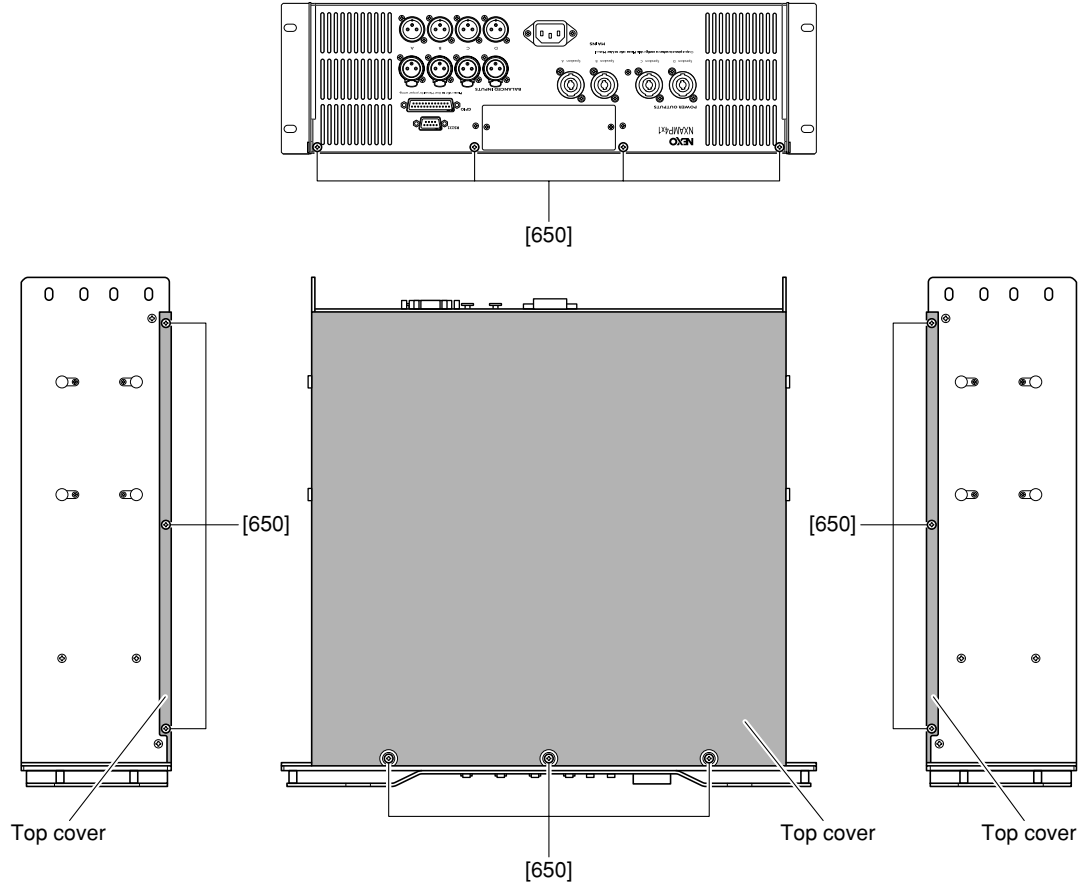

Fig. 33

DISASSEMBLY PROCEDURES

1. Top Cover (Time required: about 3 minutes)

- 1-1. Remove the thirteen (13) screws marked [650]. (Fig. 1)
- 1-2. The top cover can then be removed. (Fig. 1)



[650]: Bind Head Screw 4x8 MFZN2B3 (--)

(Fig. 1)

**2. CONTROL Circuit Board, OPT angle and OPT-AN Circuit Board
(Time required: about 10 minutes)**

- 2-1. Remove the top cover. (See procedure 1.)
- 2-2. Remove the four (4) screws marked [430]. (Fig. 2)
- 2-3. Disconnect the connector assemblies from other units connected to the CONTROL circuit board. (Fig. 2)
- 2-4. The CONTROL circuit board can then be removed. (Fig. 2)
- 2-5. Remove the three (3) screws marked [400] and the two (2) screws marked [410]. (Fig. 2)
- 2-6. Remove the OPT angle with the OPT-AN circuit board. (Fig. 2)
- 2-7. Remove the two (2) screws marked [380]. (Fig. 2)
- 2-8. The OPT-AN circuit board can then be removed. (Fig. 2)

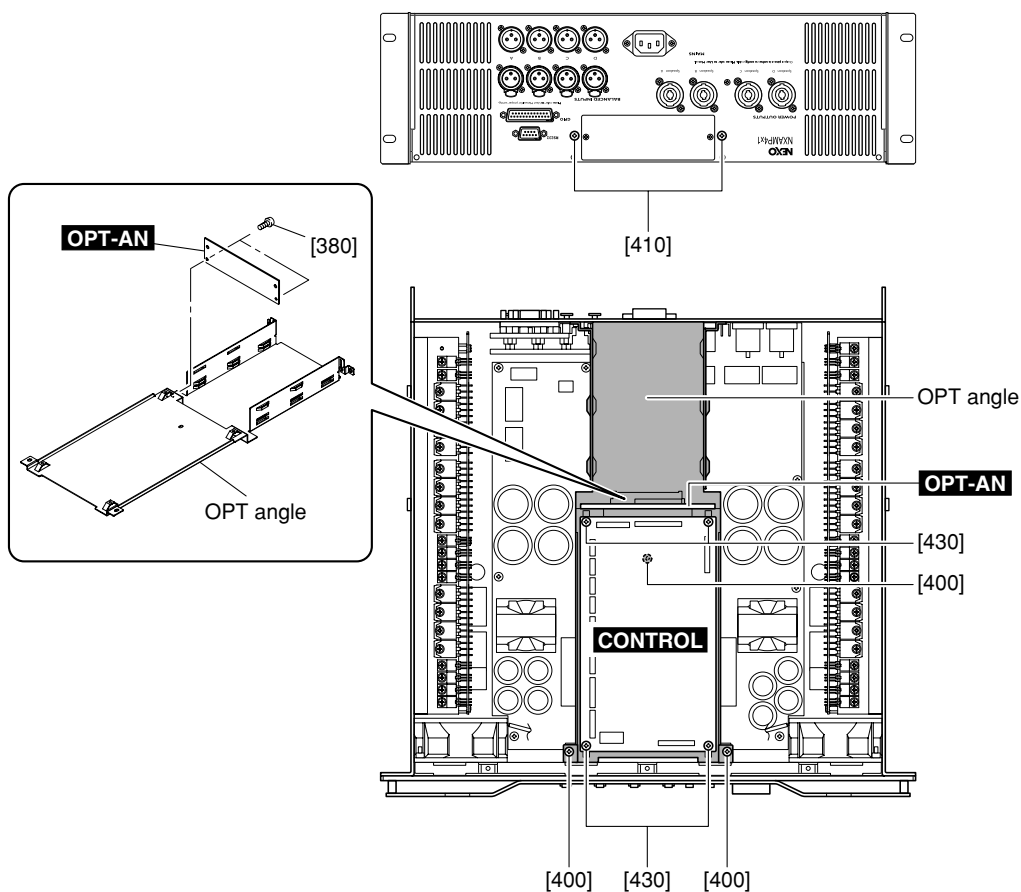

- [380]: Bind Head Tapping Screw-S 3x6 MFZN2W3 (--)
- [400]: Bind Head Tapping Screw-S 3x6 MFZN2W3 (--)
- [410]: Bind Head Tapping Screw-S 3x6 MFZN2B3 (--)
- [430]: Bind Head Tapping Screw-S 3x6 MFZN2W3 (--)

(Fig. 2)

3. OUTANL Circuit Board (Time required: about 15 minutes)

- 3-1. Remove the top cover. (See procedure 1.)
- 3-2. Remove the CONTROL circuit board and the OPT angle. (See procedure 2.)
- 3-3. Remove the eight (8) screws marked [280], the one (1) screw marked [290] and the one (1) screw marked [285]. (Fig. 3)
- 3-4. Disconnect the connector assemblies from other units connected to the OUTANL circuit board. (Fig. 3)
- 3-5. The OUTANL circuit board with the two (2) insulation sheets and the two (2) shields can then be removed. (Fig. 3)
- 3-6. Remove the three (3) plastic rivets marked [277]. (Fig. 3)
- 3-7. Remove the insulation sheet 1, the shield 1, the shield 2 and the insulation sheet 2 from the OUTANL circuit board. (Fig. 3)

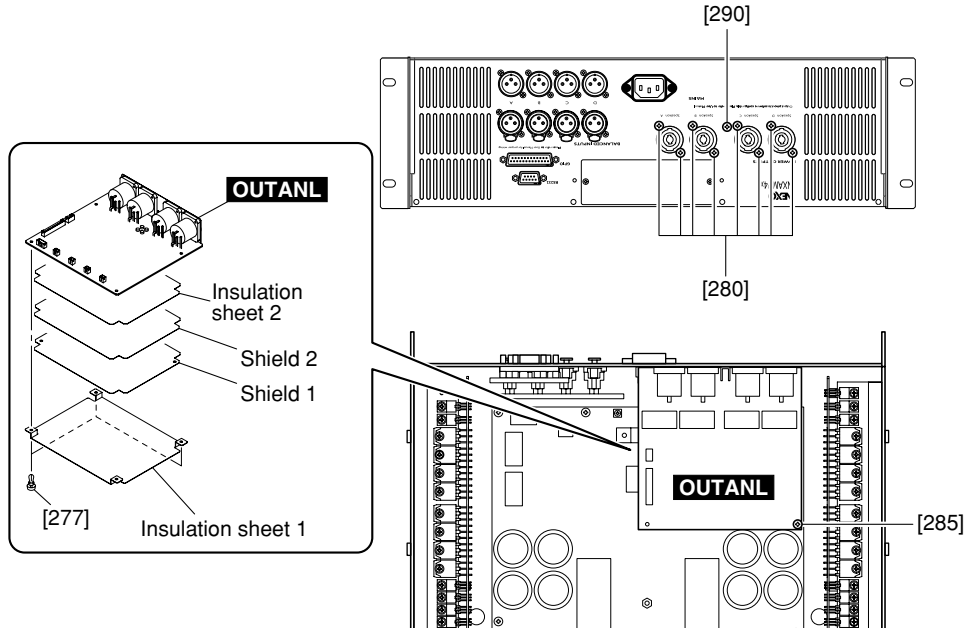

- [277]: Plastic Rivet NRP-345 (--)
- [280]: Flat Head Tapping Screw-B 3x8 MFZN2B3 (--)
- [285]: Bind Head Tapping Screw-S 3x6 MFZN2W3 (--)
- [290]: Bind Head Tapping Screw-B 3x8 MFZN2B3 (--)

(Fig. 3)

4. PSANL Circuit Board (Time required: about 20 minutes)

- 4-1. Remove the top cover. (See procedure 1.)
- 4-2. Remove the CONTROL circuit Board and the OPT angle. (See procedure 2.)
- 4-3. Remove the OUTANL Circuit Board. (See procedure 3.)
- 4-5. Remove the two (2) screws marked [150], and remove the ACPS connector assembly. (Fig. 4)
- 4-6. Remove the nine (9) screws marked [100], the one (1) hexagonal spacers marked [90] and the one (1) hexagonal spacer marked [95]. (Fig. 4)
- 4-7. Disconnect the connector assemblies from other units connected to the PSANL circuit board. (Fig. 4)
- 4-8. The PSANL circuit board can then be removed. (Fig. 4)

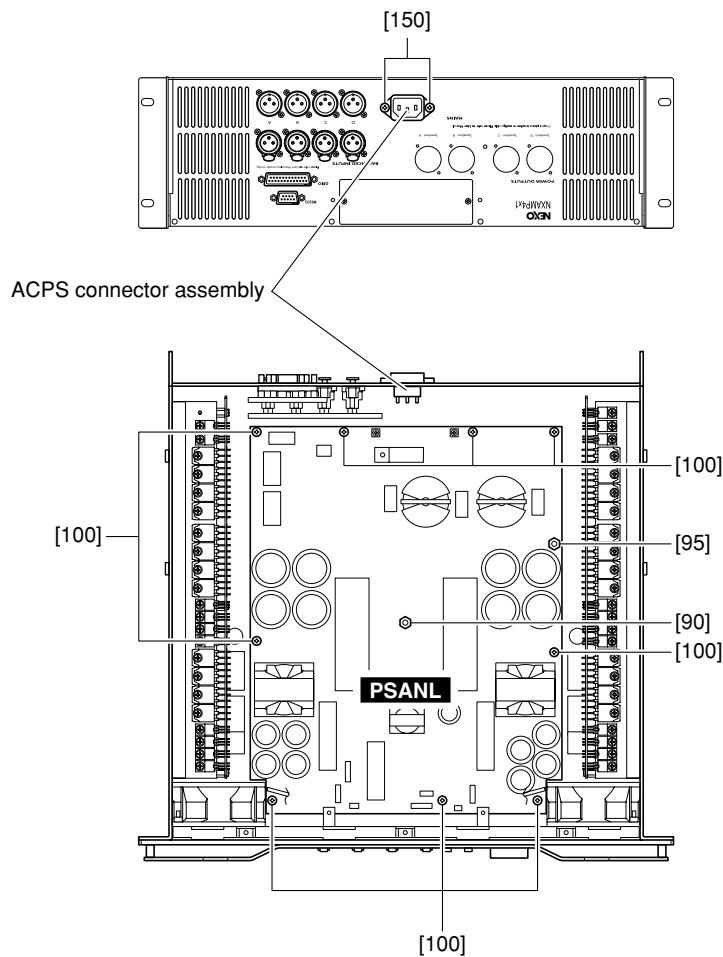

- [90]: Hexagonal Spacer H=89 B=5.5 (--)
- [95]: Hexagonal Spacer H=41 B=5.5 (--)
- [100]: Bind Head Tapping Screw-S 3x6 MFZN2W3 (--)
- [150]: Flat Head Tapping Screw-B 3x8 MFZN2B3 (--) (U destination)
- [150]: Bind Head Tapping Screw-B 3x8 MFZN2B3 (--)

(Fig. 4)

**5. INANL Circuit Board
(Time required: about 7 minutes)**

- 5-1. Remove the top cover. (See procedure 1.)
- 5-2. Remove the sixteen (16) screws marked [70]. (Fig. 5)
- 5-3. Disconnect the connector assembly from other unit connected to the INANL circuit board. (Fig. 5)
- 5-4. The INANL circuit board can then be removed. (Fig. 5)

**6. RS232-GPI Circuit Board
(Time required: about 7 minutes)**

- 6-1. Remove the top cover. (See procedure 1.)
- 6-2. Remove the four (4) hexagonal lock screws marked [330]. (Fig. 5)
- 6-3. Disconnect the flat cable from other unit connected to the RS232-GPI circuit board. (Fig. 5)
- 6-4. The RS232-GPI circuit board can then be removed. (Fig. 5)

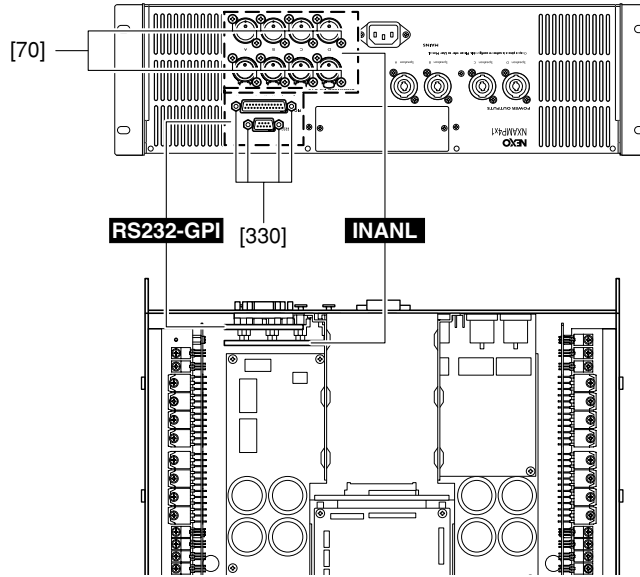

[70]: Bind Head Tapping Screw-B 2.6x8 MFZN2B3 (--)

[330]: Hexagonal Lock Screw (--)

(Fig. 5)

7. Left (CH1, CH2) PA unit

(Time required: about 15 minutes)

- 7-1. Remove the top cover. (See procedure 1.)
- 7-2. Remove the CONTROL circuit board and the OPT angle. (See procedure 2.)
- 7-3. Remove the four (4) screws marked [670A], and remove the four (4) screw covers marked [660A]. (Fig. 6)
- 7-4. Remove the six (6) screws marked [220]. (Fig. 6)
- 7-5. Disconnect the connector assemblies that connects the left PA unit and other units. (Fig. 6)
- 7-6. The left PA unit can then be removed. (Fig. 6)

8. Right (CH3, CH4) PA unit

(Time required: about 15 minutes)

- 8-1. Remove the top cover. (See procedure 1.)
- 8-2. Remove the CONTROL circuit board and the OPT angle. (See procedure 2.)
- 8-3. Remove the four (4) screws marked [670B], and remove the four (4) screw covers marked [660B]. (Fig. 6)
- 8-4. Remove the six (6) screws marked [260]. (Fig. 6)
- 8-5. Disconnect the connector assemblies that connects the right PA unit and other units. (Fig. 6)
- 8-6. The right PA unit can then be removed. (Fig. 6)

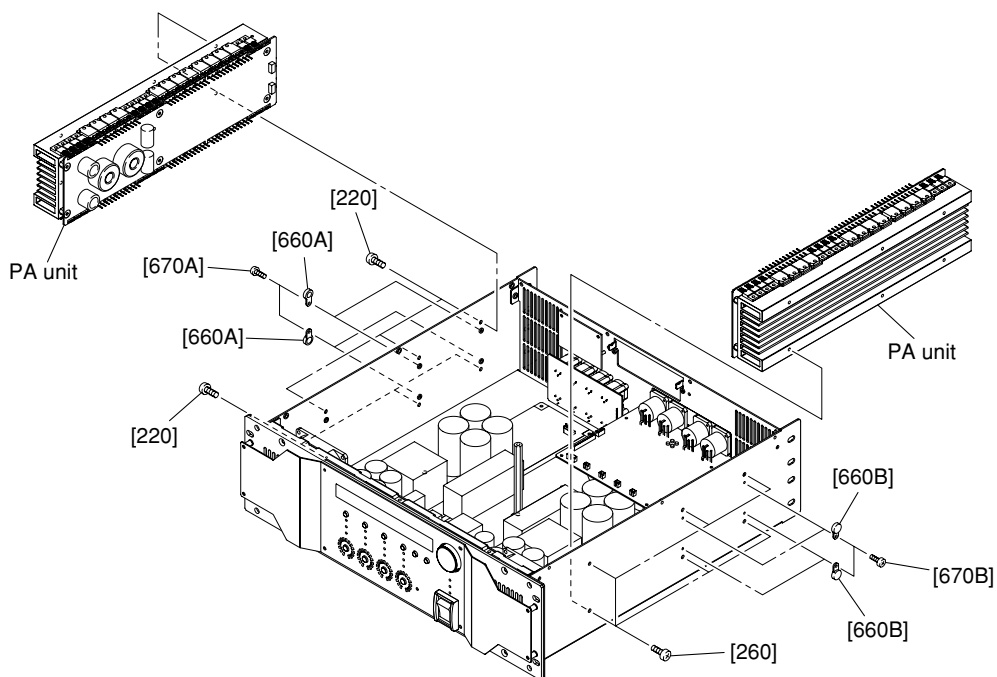

- [220]: Bind Head Screw 4x8 MFZN2B3 (--)
- [260]: Bind Head Screw 4x8 MFZN2B3 (--)
- [660A]: Screw Cover T5N (--)
- [660B]: Screw Cover T5N (--)
- [670A]: Bind Head Tapping Screw-B 3x8 MFZN2B3 (--)
- [670B]: Bind Head Tapping Screw-B 3x8 MFZN2B3 (--)

(Fig. 6)

**9. Front Panel Assembly
(Time required: about 6 minutes)**

- 9-1. Remove the top cover. (See procedure 1.)
- 9-2. Remove the CONTROL circuit Board and the OPT angle. (See procedure 2.)
- 9-3. Remove the eight (8) screws marked [590]. (Fig. 7)
- 9-4. Remove the front panel 2. (Fig. 7)
- 9-5. Disconnect the connector of the power switch assembly connected to the PSANL circuit board. (Fig. 7)
- 9-6. Remove the eight (8) screws marked [510]. (Fig. 7)
- 9-7. Disconnect the flat cable from other unit connected to the PN-AN circuit board. (Fig. 7)
- 9-8. The front panel assembly can be removed. (Fig. 7)

**10. PN-AN Circuit Board
(Time required: about 10 minutes)**

- 10-1. Remove the top cover. (See procedure 1.)
- 10-2. Remove the front panel assembly. (See procedure 9.)
- 10-3. Remove the five (5) screws marked [500]. (Fig. 7)
- 10-4. Remove the LCD assembly. (Fig. 7)
- 10-5. Remove the four (4) nylon rivets [40]. (Fig. 7)
- 10-6. The PN-AN circuit board and the LCD unit can then be separated. (Fig. 7)

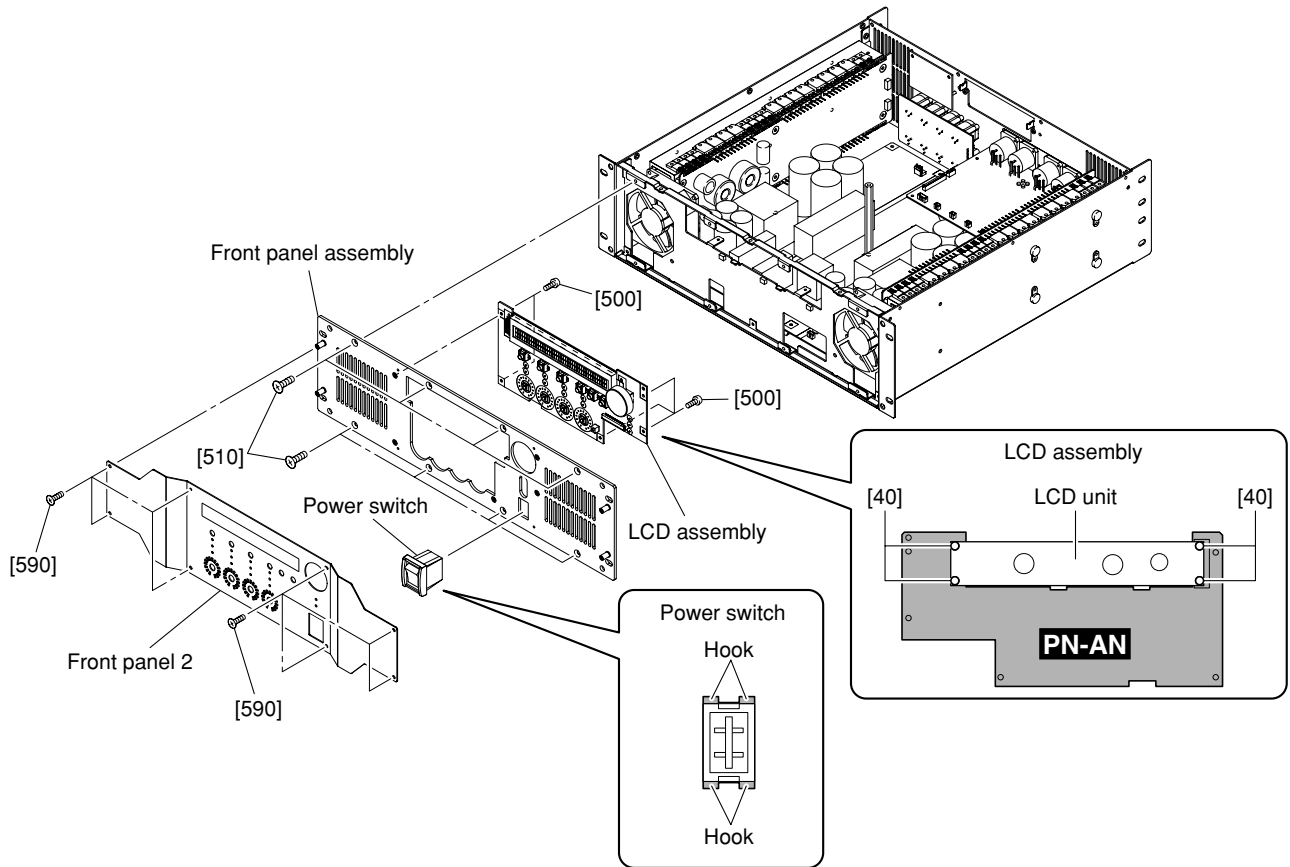

- [40]: Nylon Rivet (--)
- [500]: Bind Head Screw 3x4 MFZN2B3 (--)
- [510]: Flat Head Screw 4x8 MFZN2B3 (--)
- [590]: Bind Head Tapping Screw-S 3x6 MFZN2B3 (--)

(Fig. 7)

11. Left DC Fan (Time required: about 15 minutes)

- 11-1. Remove the top cover. (See procedure 1.)
- 11-2. Remove the CONTROL circuit board and the OPT angle. (See procedure 2.)
- 11-3. Remove the front panel assembly. (See procedure 9.)
- 11-4. Remove the two (2) screws marked [40A] and the two (2) hexagonal nuts marked [50A]. (Fig. 8)
- 11-5. Disconnect the connector of the left DC fan connected to the PSANL circuit board. (Fig. 8)
- 11-6. The left DC fan can then be removed. (Fig. 8)

12. Right DC fan (Time required: about 15 minutes)

- 12-1. Remove the top cover. (See procedure 1.)
- 12-2. Remove the CONTROL circuit board and the OPT angle. (See procedure 2.)
- 12-3. Remove the front panel assembly. (See procedure 9.)
- 12-4. Remove the two (2) screws marked [40B] and the two (2) hexagonal nuts marked [50B]. (Fig. 8)
- 12-5. Disconnect the connector of the right DC fan connected to the PSANL circuit board. (Fig. 8)
- 12-6. The right DC fan can then be removed. (Fig. 8)

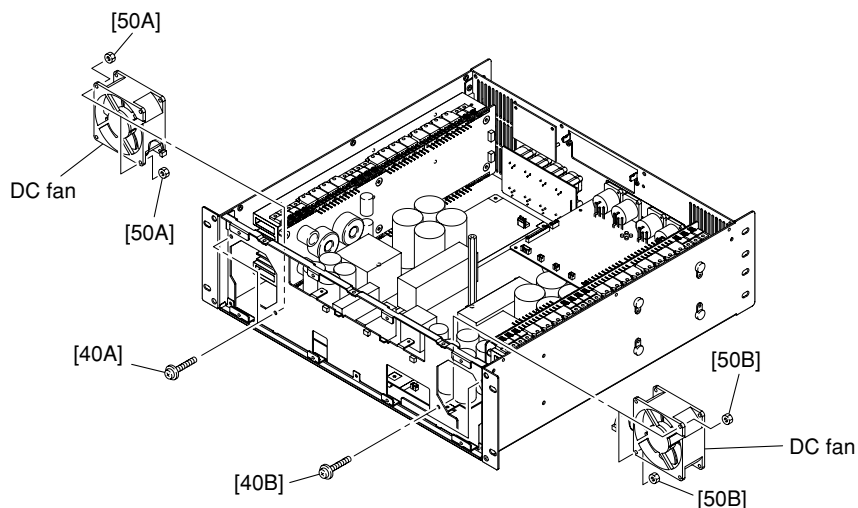

- [40A]: Bind Head Screw 4x35 MFZN2W3 SP (--)
- [40B]: Bind Head Screw 4x35 MFZN2W3 SP (--)
- [50A]: Hexagonal Nut M4 #1 (--)
- [50B]: Hexagonal Nut M4 #1 (--)

(Fig. 8)

13. Power switch (Time required: about 15 minutes)

- 13-1. Remove the top cover. (See procedure 1.)
- 13-2. Remove the CONTROL circuit Board and the OPT angle. (See procedure 2.)
- 13-3. Disconnect the connector of the power switch assembly connected to the PSANL circuit board. (Fig. 9)
- 13-4. Remove the front panel assembly. (See procedure 9.)
- 13-5. Release the four (4) hooks of the power switch, and remove the power switch from the front panel assembly. (Fig. 9)

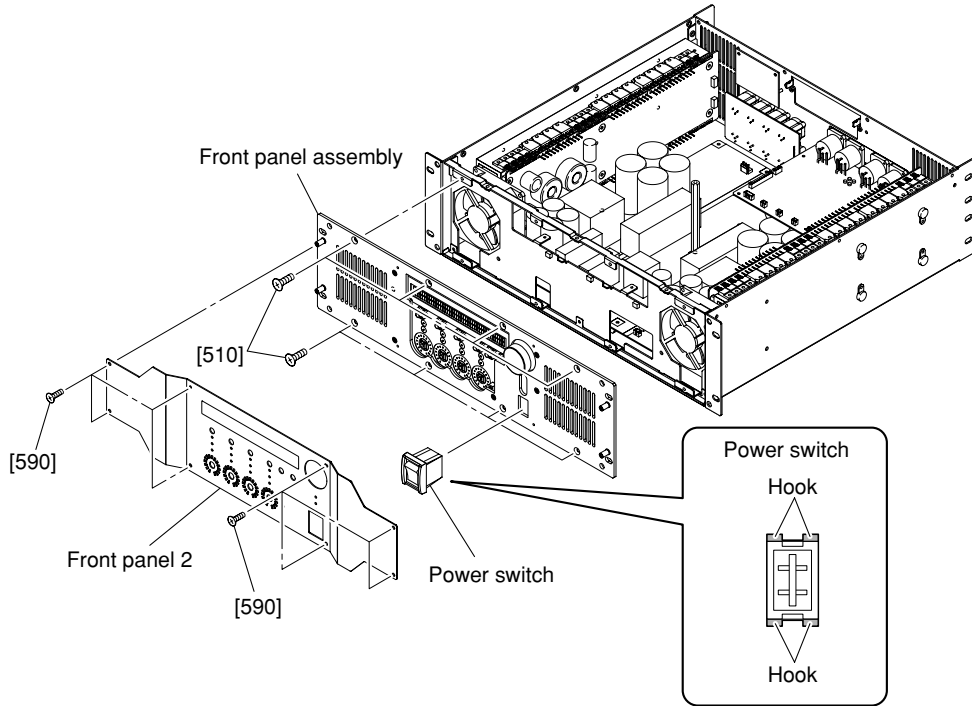

[510]: Flat Head Screw 4x8 MFZN2B3 (--)

[590]: Bind Head Tapping Screw-S 3x6 MFZN2B3 (--)

(Fig. 9)

■ LSI PIN DESCRIPTION

• PCM1803ADBR (X7357B0) A/D CONVERTER

CONTROL: IC035, IC036, IC037, IC038

PIN NO.	NAME	I/O	FUNCTION
1	V _{INL}	I	Analog input, L-channel
2	V _{INR}	I	Analog input, R-channel
3	V _{REF1}	–	Reference voltage 1 decoupling capacitor
4	V _{REF2}	–	Reference voltage 2 decoupling capacitor
5	V _{CC}	–	Analog power supply, 5 V
6	AGND	–	Analog GND
7	PDWN	I	Power-down control, active-low ⁽²⁾
8	BYPAS	I	HPF bypass control / LOW: Normal mode (dc reject); HIGH: Bypass mode (through) ⁽²⁾
9	TEST	I	Test, must be connected to DGND ⁽²⁾
10	LRCK	I/O	Audio data latch enable input/output ⁽¹⁾
11	BCK	I/O	Audio data bit clock input/output ⁽¹⁾
12	DOUT	O	Audio data digital output
13	DGND	–	Digital GND
14	V _{DD}	–	Digital power supply, 3.3 V
15	SCKI	I	System clock input: 256 fs, 384 fs, 512 fs or 768 fs ⁽³⁾
16	OSR	I	Oversampling ratio select input / LOW: x 64 fs, HIGH: x 128 fs ⁽²⁾
17	FMT0	I	Audio data format select input 0 / See data format section ⁽²⁾
18	FMT1	I	Audio data format select input 1 / See data format section ⁽²⁾
19	MODE0	I	Mode select input 0 / See data format section ⁽²⁾
20	MODE1	I	Mode select input 1 / See data format section ⁽²⁾

(1) Schmitt trigger input

(2) Schmitt trigger input with internal pulldown (50 k Ω , typically), 5 V tolerant

(3) Schmitt trigger input, 5 V tolerant

IC BLOCK DIAGRAM

• **74HCT273PW,118 (X8681A0)**

D-type Flip Flop
PN-AN: IC002, 003

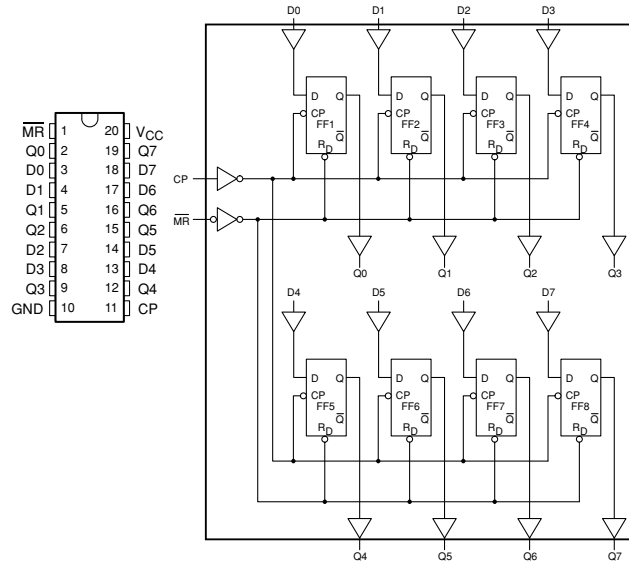

• **74LVC169PW,118 (X8482A0)**

Binary Counter
CONTROL: IC044, 045

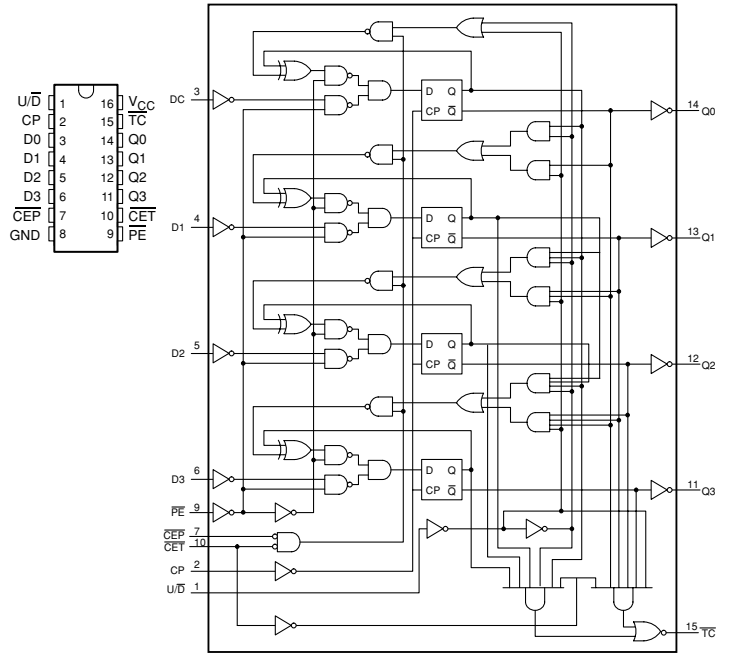

• **74HCT4514PW,118 (X8630A0)**

Decoder
PN-AN: IC004-007

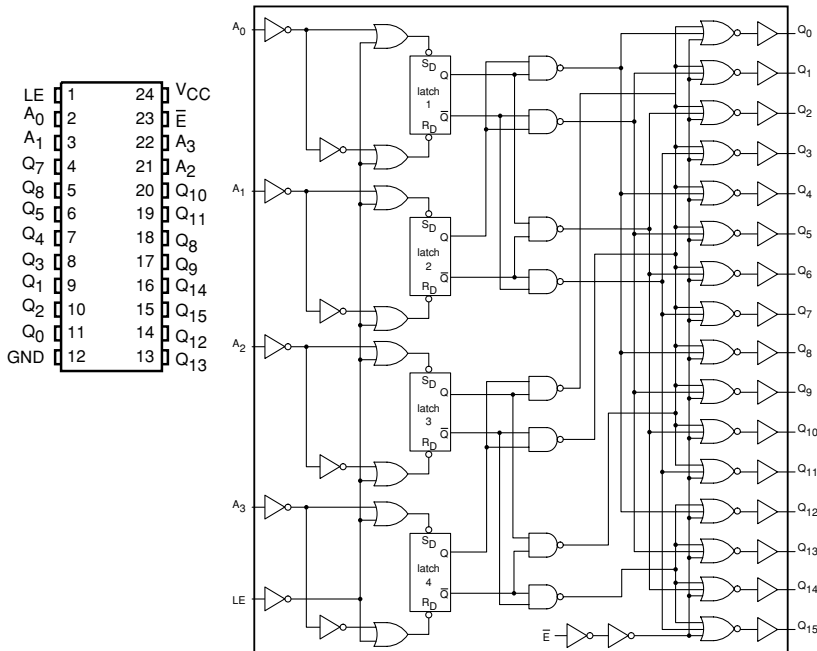

• **CS3318-CQZ (X8486A0)**

Volume Controller
CONTROL: IC001

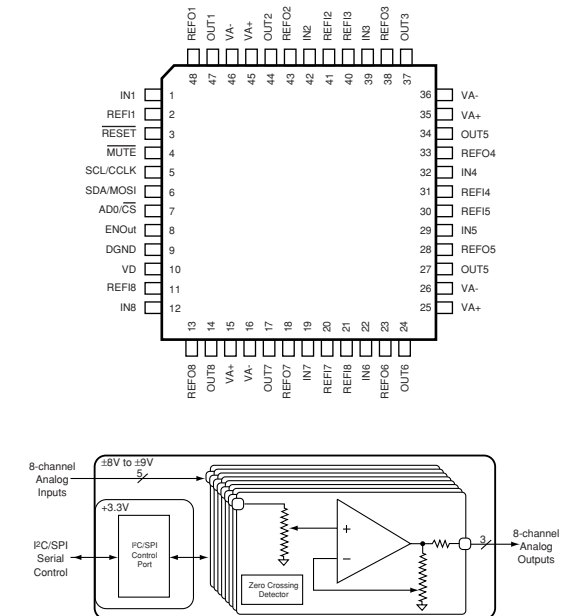

• **CS4272-CZZR (X8487A0)**

CODEC
CONTROL: IC012, 013

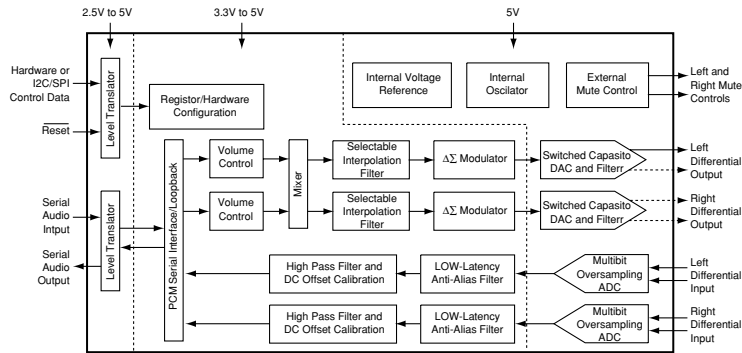

• **DSPB56371AF180 (X8489A0)**

DSP
CONTROL: IC022, 023

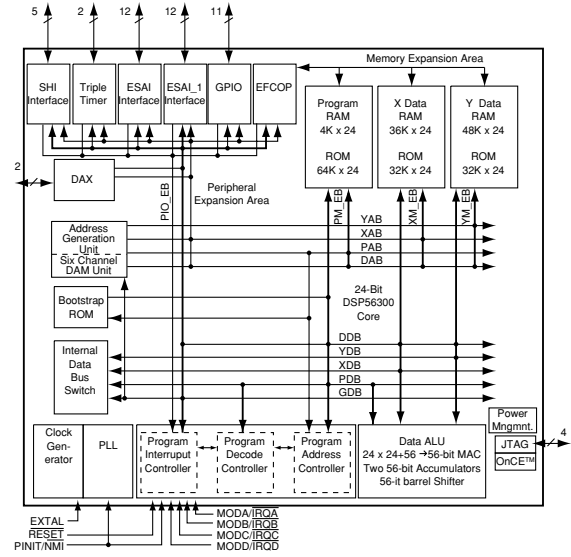

• **IR2110 (X2382A02)**

Driver
PSANL: IC302, 303

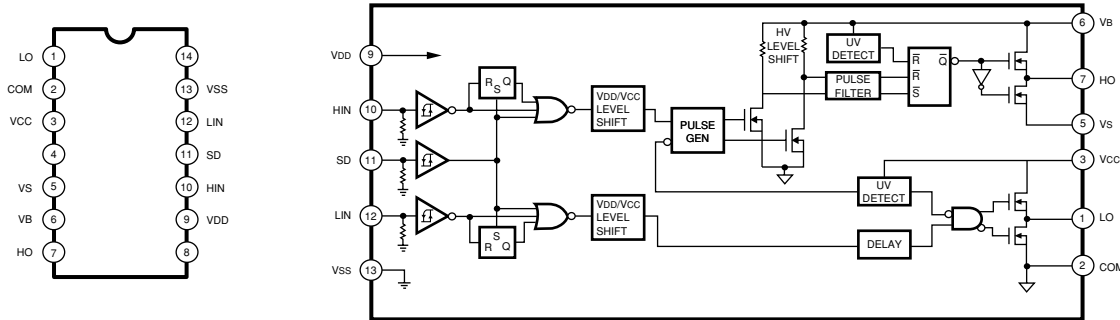

• **LD1117STR (X8495A0)**

Regulator
CONTROL: IC024

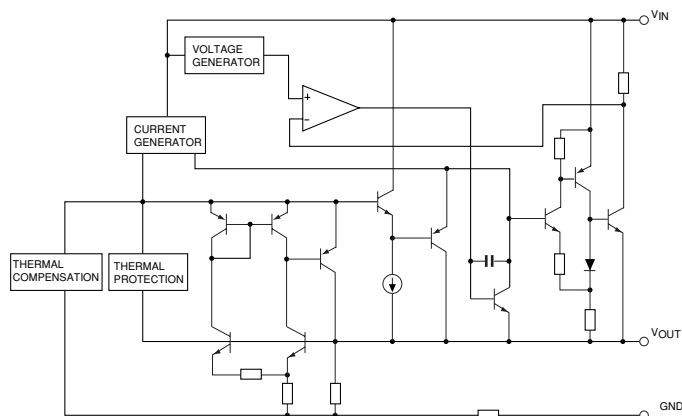

• **MAX3221CPWR (X2757A0)**

RS-232C Driver
CONTROL: IC041

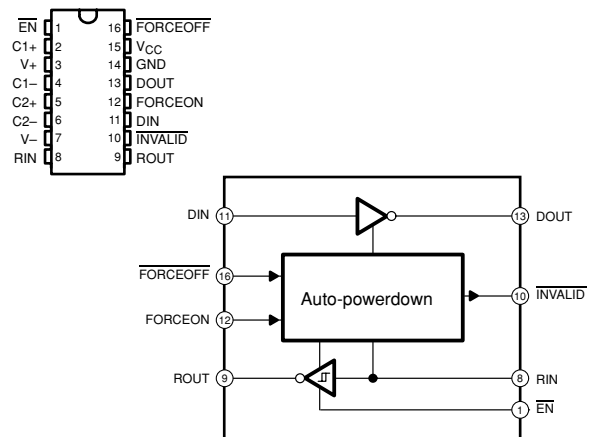

- **MX25L1605AM2C-12G** (X8718A0)
Flash Memory
CONTROL: IC039

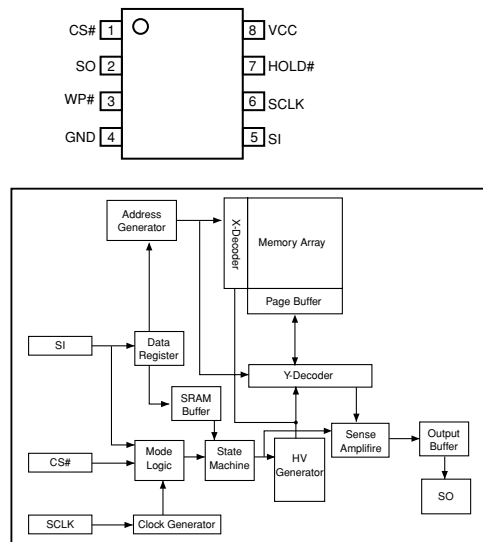

- **NJM431U (TE1)** (X6770A0)
SHUNT Regulator
PSANL: IC204

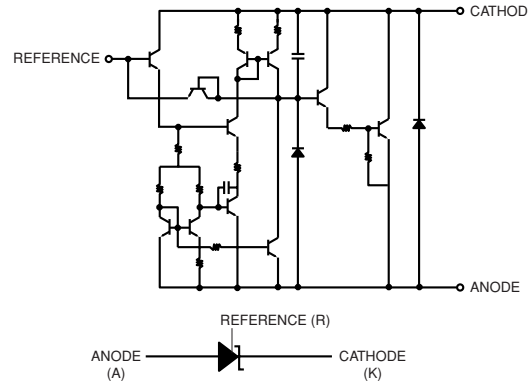

- **NJM2068M-D** (X3505A0)
Operational Amplifier
CONTROL: IC002-005, 008-011, 018-021, 028-034
INANL: IC701, 702
OUTANL: IC801, 802

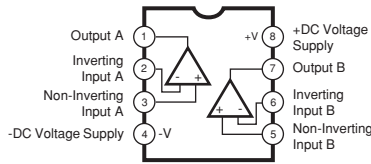

- **NJM79M09DL1A** (X5366A0)
Regulator
CONTROL: IC007

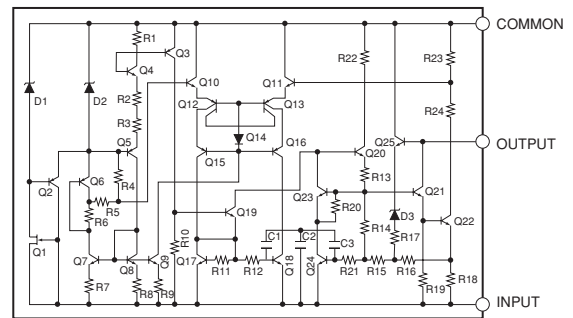

- **NJM2904V (TE1)** (XR532A0)
Operational Amplifier
CONTROL: IC047, 048, 050, 052

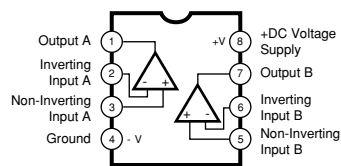

- **NJM7815FA** (XD853A0)
Regulator +15V
PSANL: IC202, 203

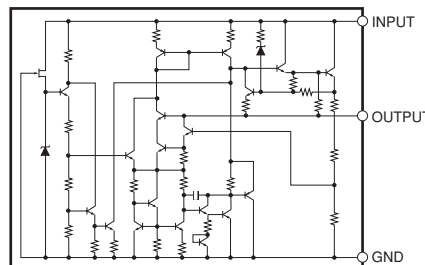

- **NJM78M09DL1A** (XZ940A0)
Regulator
CONTROL: IC006

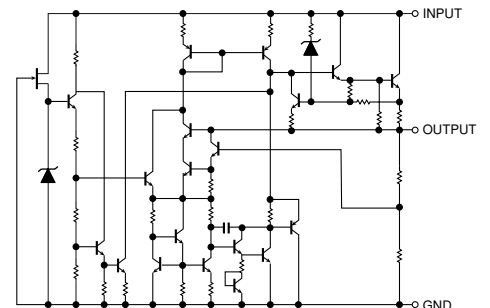

- **NJU7630-M** (X8682A0)
Regulator
PSANL: IC205

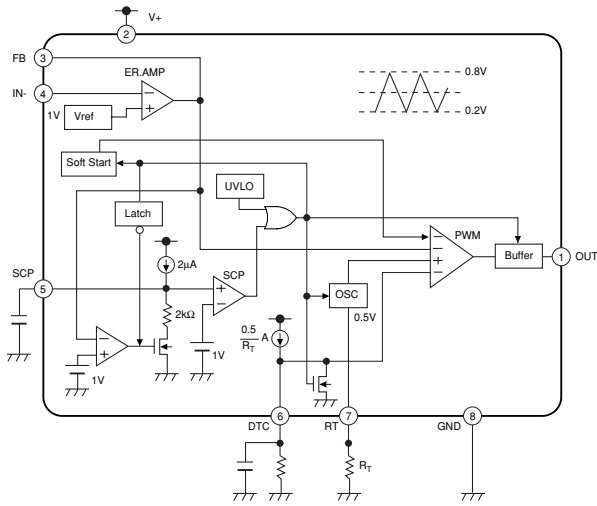

- **PCM1803ADBR** (X7357B0)
A/D Converter
CONTROL: IC035-038

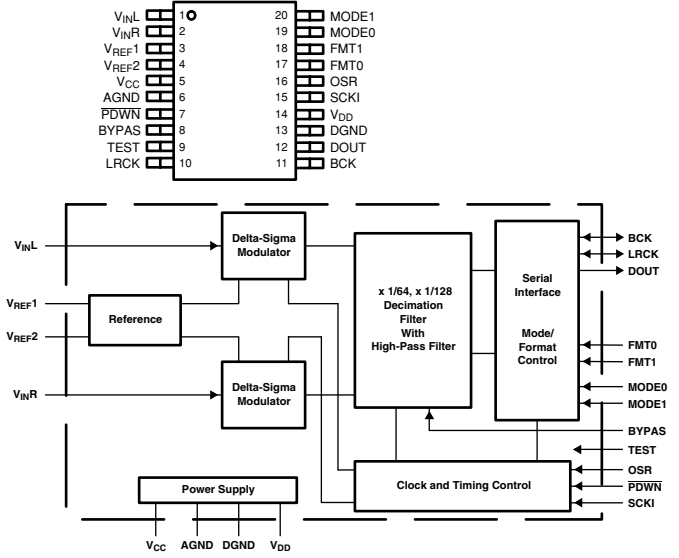

- **PQ1CX12H2ZP** (X6188A0)
Regulator
PSANL: IC208

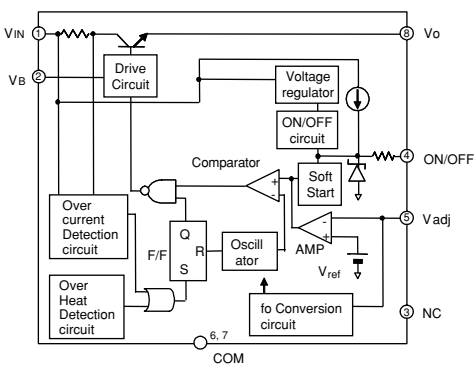

- **SG2525AN** (X8960A0)
PW Modulator
PSANL: IC301

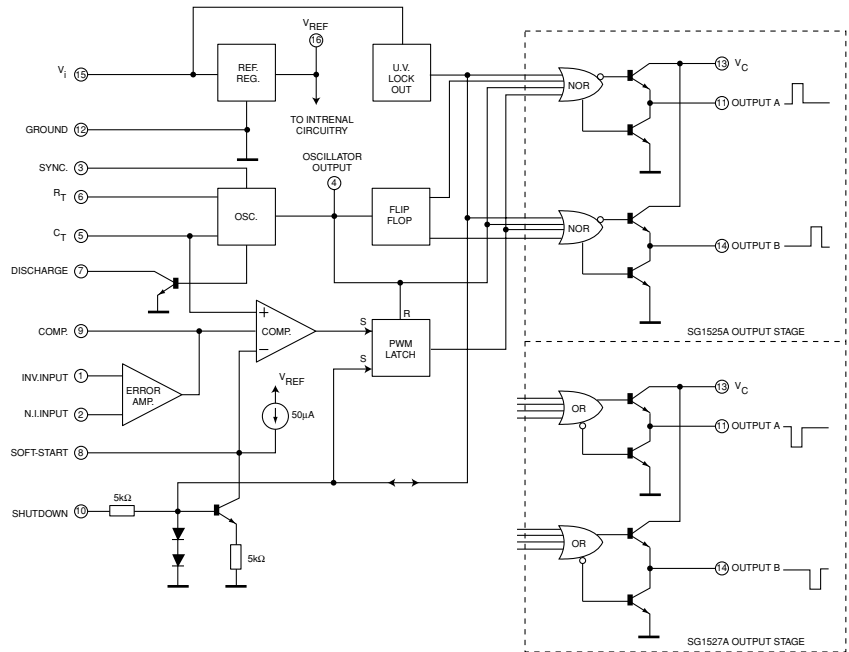

- **SN74ABT245BNSR (XU009A0)**
 BUS Transceiver
 CONTROL: IC062

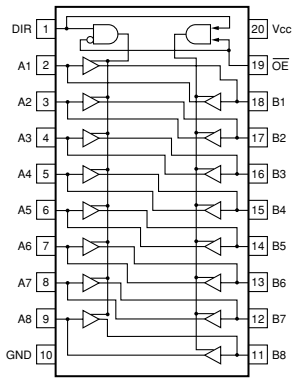

- **SN74LV14APWR (X6688A0)**
 Inverter
 CONTROL: IC063

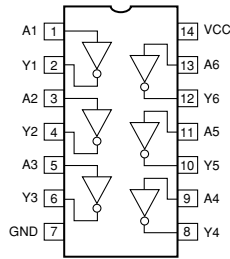

- **SN74LV273APWR (X5074A0)**
 D-type Flip Flop
 CONTROL: IC057-061

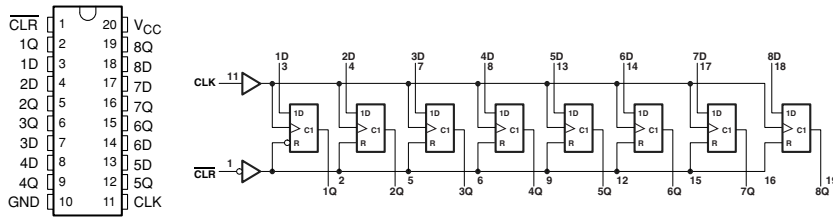

- **SN74LV541APWRBUS B (X5966A0)**
 Buffer/Driver
 CONTROL: IC055, 056
 PN-AN: IC001

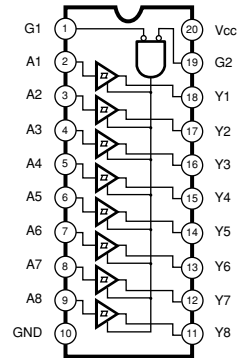

- **SN74LV4052APWR (X6976A0)**
 Demultiplexer
 CONTROL: IC049

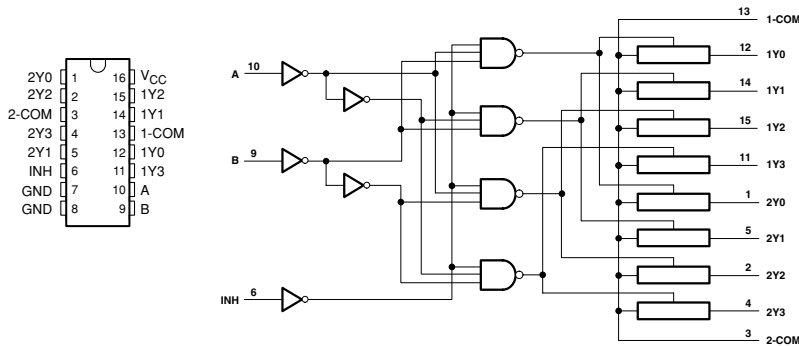

- **SN74LVC00APWR (X5406A0)**
 NAND
 CONTROL: IC040

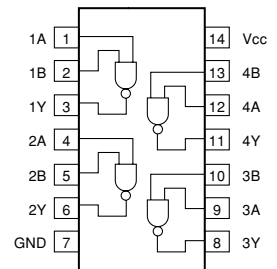

• **SN74LVC157APWR (X6786A0)**

Data Selector

CONTROL: IC046, 051

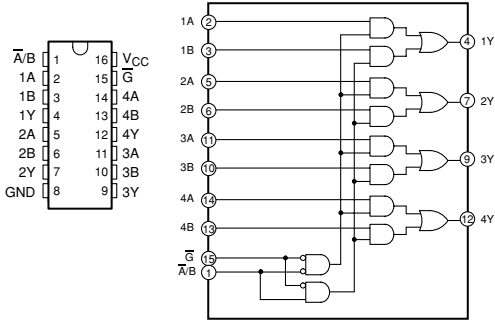

• **SN74LVC2G74DCTR (X8709A0)**

Flip Flop

CONTROL: IC042

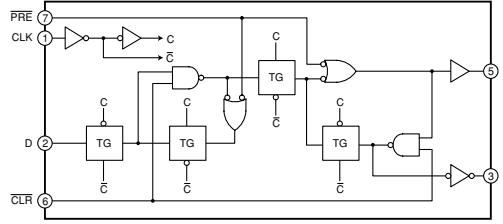

• **SN74LVC245APWR (XZ287A0)**

Bus Transceiver

CONTROL: IC054

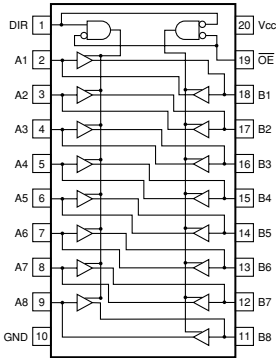

• **TC74LCX04FT (X8415A0)**

Inverter

CONTROL: IC064

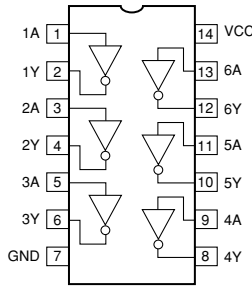

• **TOP246YN 1PD (X8576A0)**

Regulator

PSANL: IC201

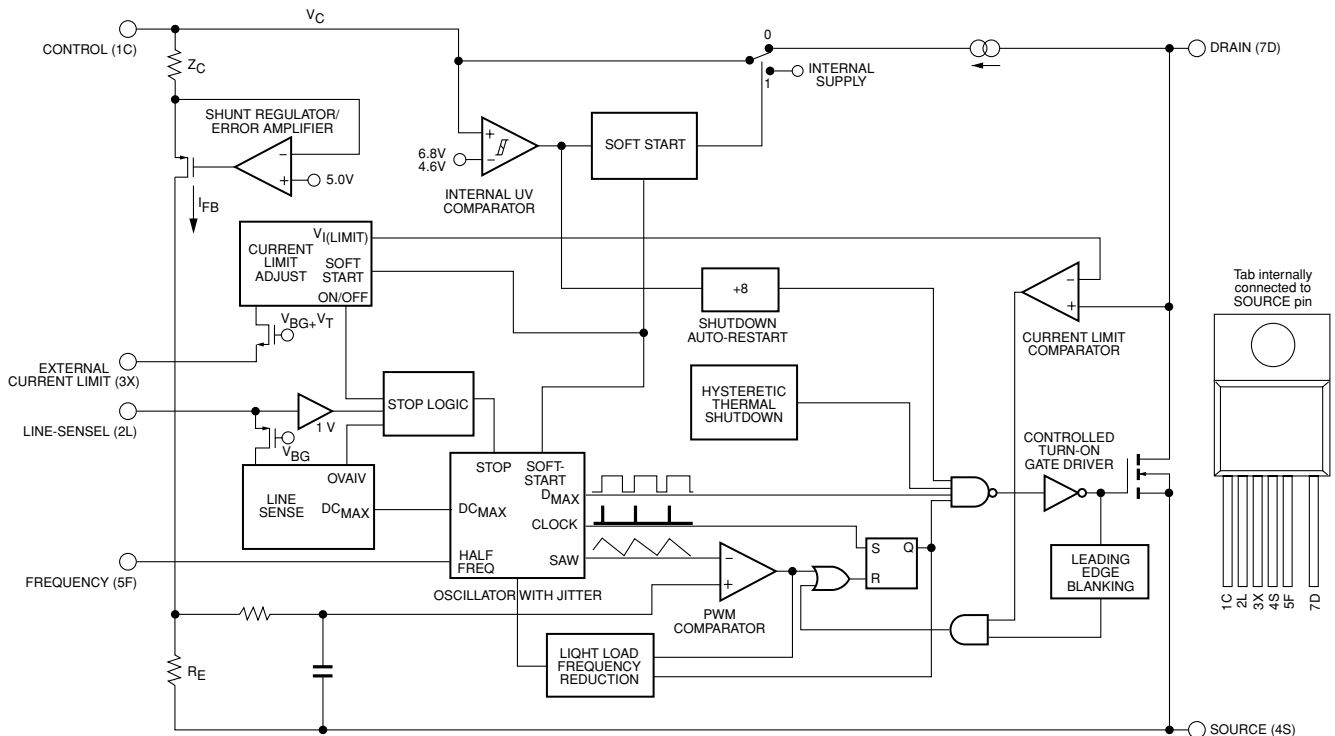

■ CIRCUIT BOARDS

CONTENTS

• CONTROL Circuit Board	(X8710C0)	34
• INANL Circuit Board	(X8714C0)	38
• LCD SPACER Circuit Board	(X8711C0)	41
• OPT-AN Circuit Board	(X8711C0)	41
• OUTANL Circuit Board	(X8714C0)	39
• PAANL Circuit Board	(X8713D0)	46
• PN-AN Circuit Board	(X8711C0)	42
• PSANL Circuit Board	(X8715D0)	47
• RS232-GPI Circuit Board	(X8711C0)	41

Note: See parts list for details of circuit board component parts.

• CONTROL Circuit Board

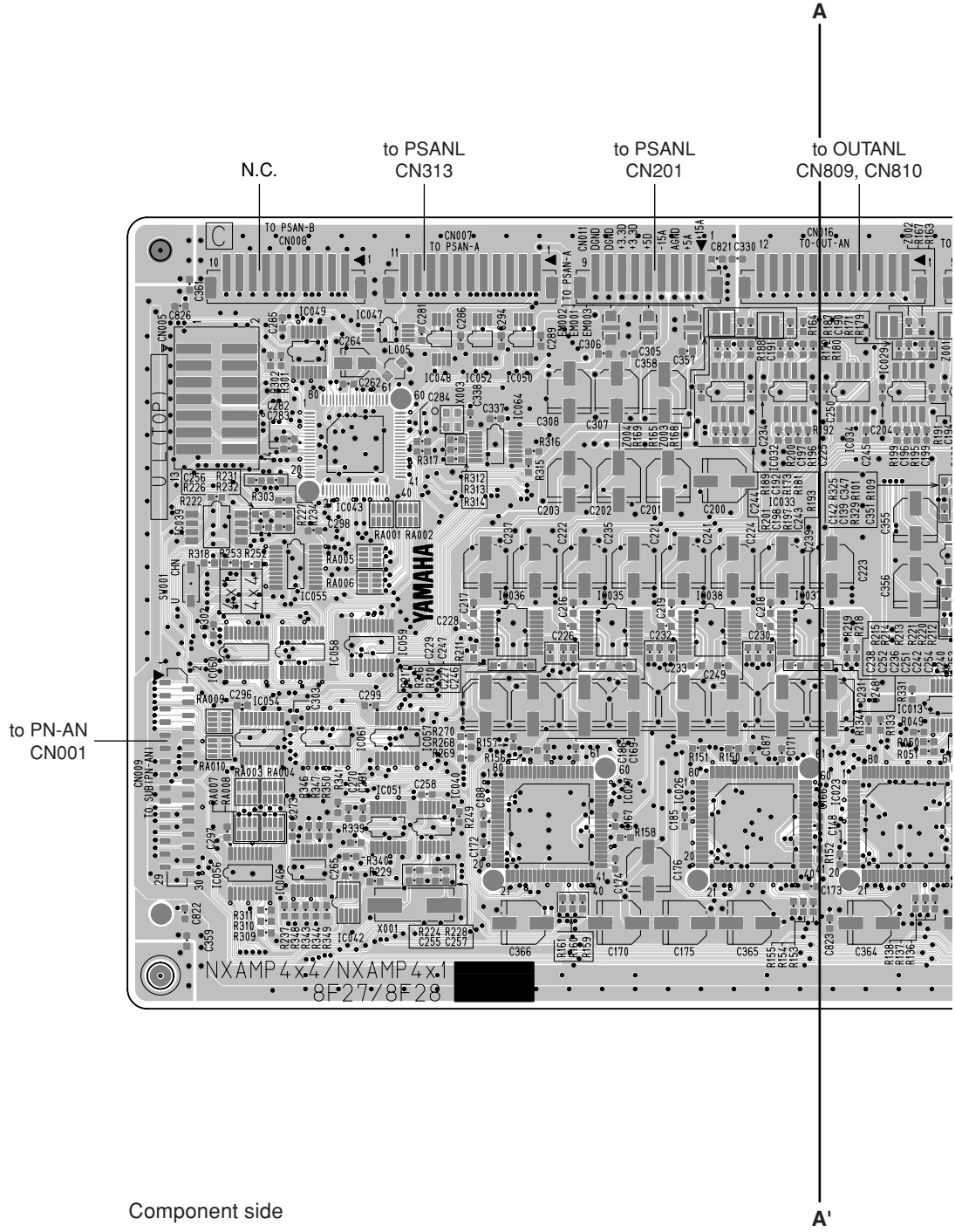

Component side

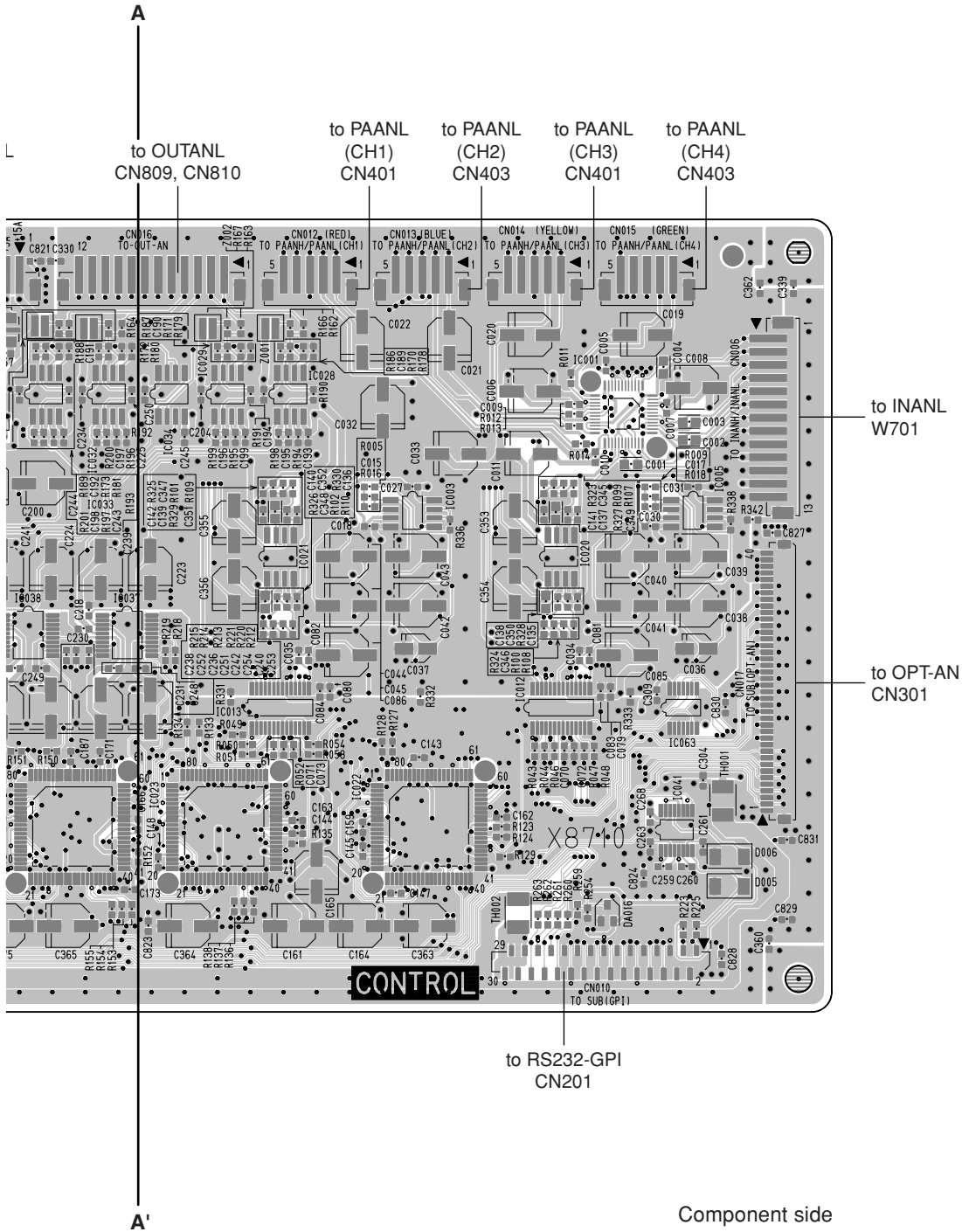

• CONTROL Circuit Board

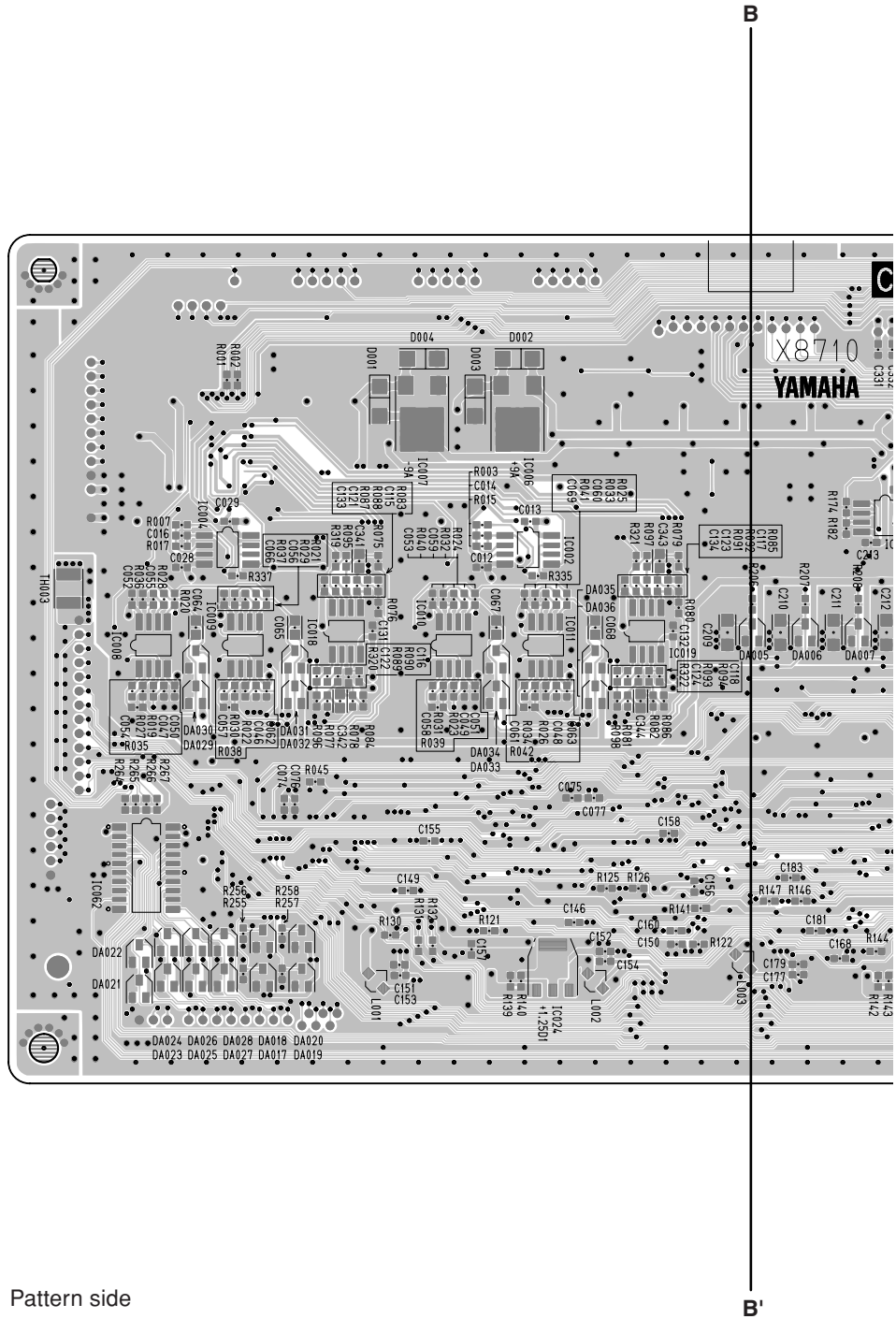

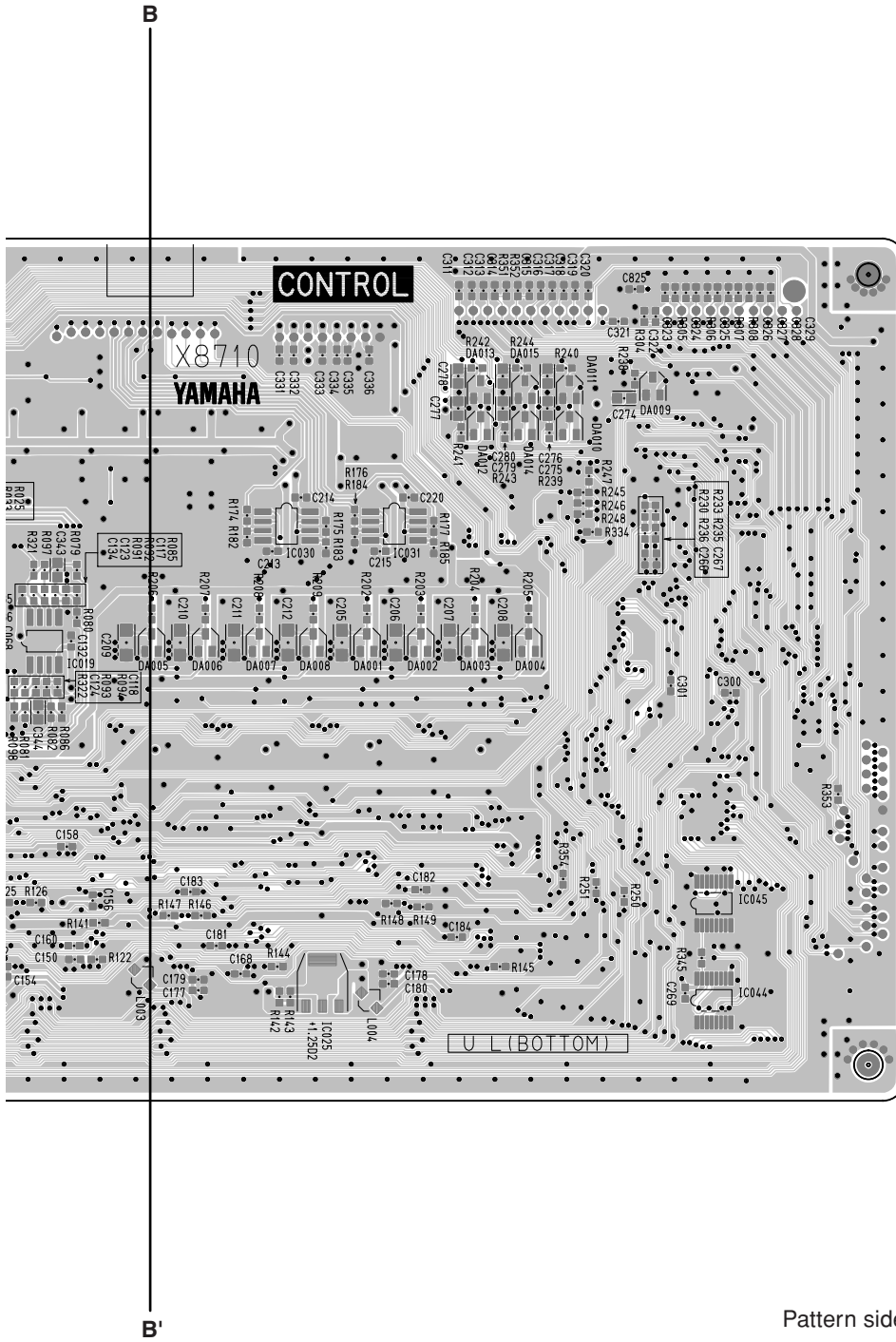

Pattern side

• INANL Circuit Board

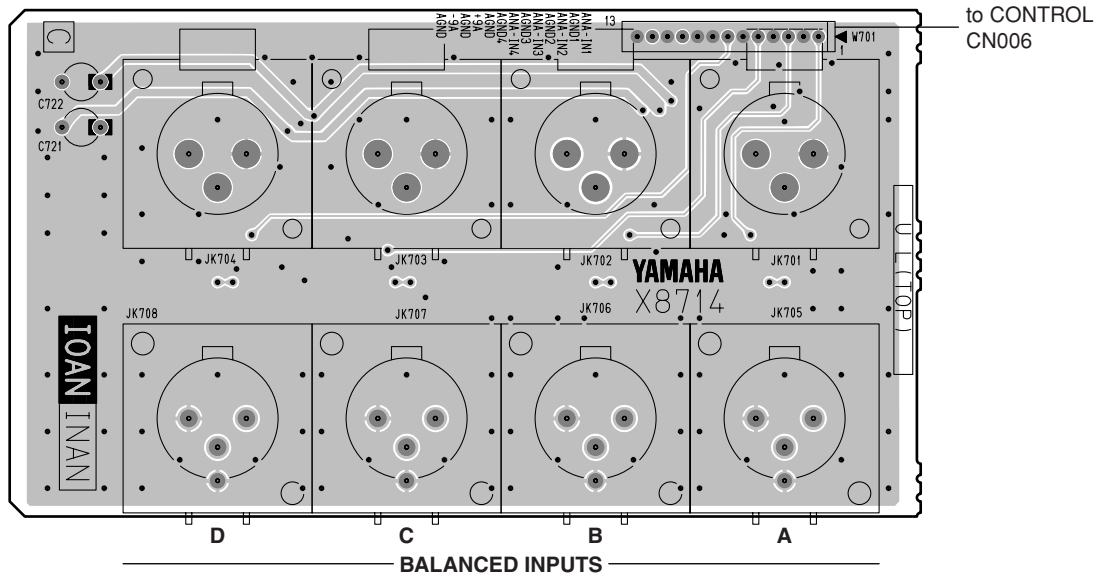

Component side

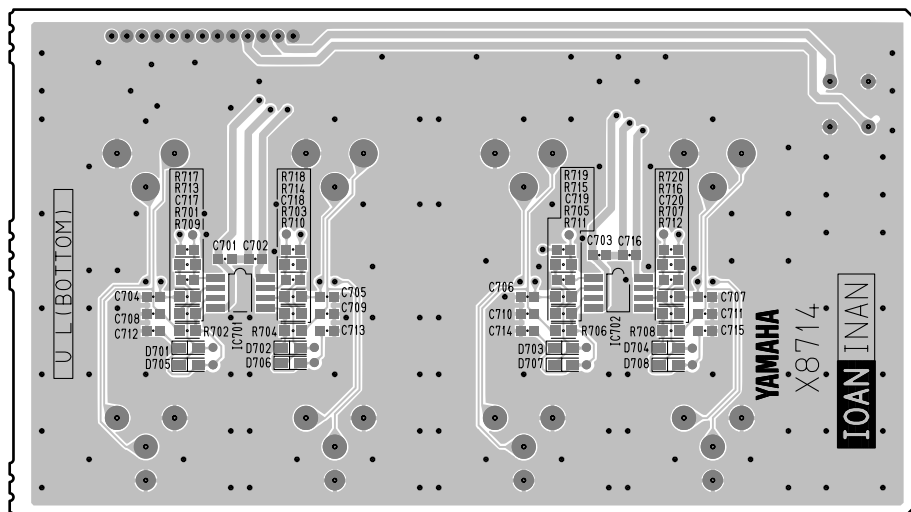

Pattern side

• OUTANL Circuit Board

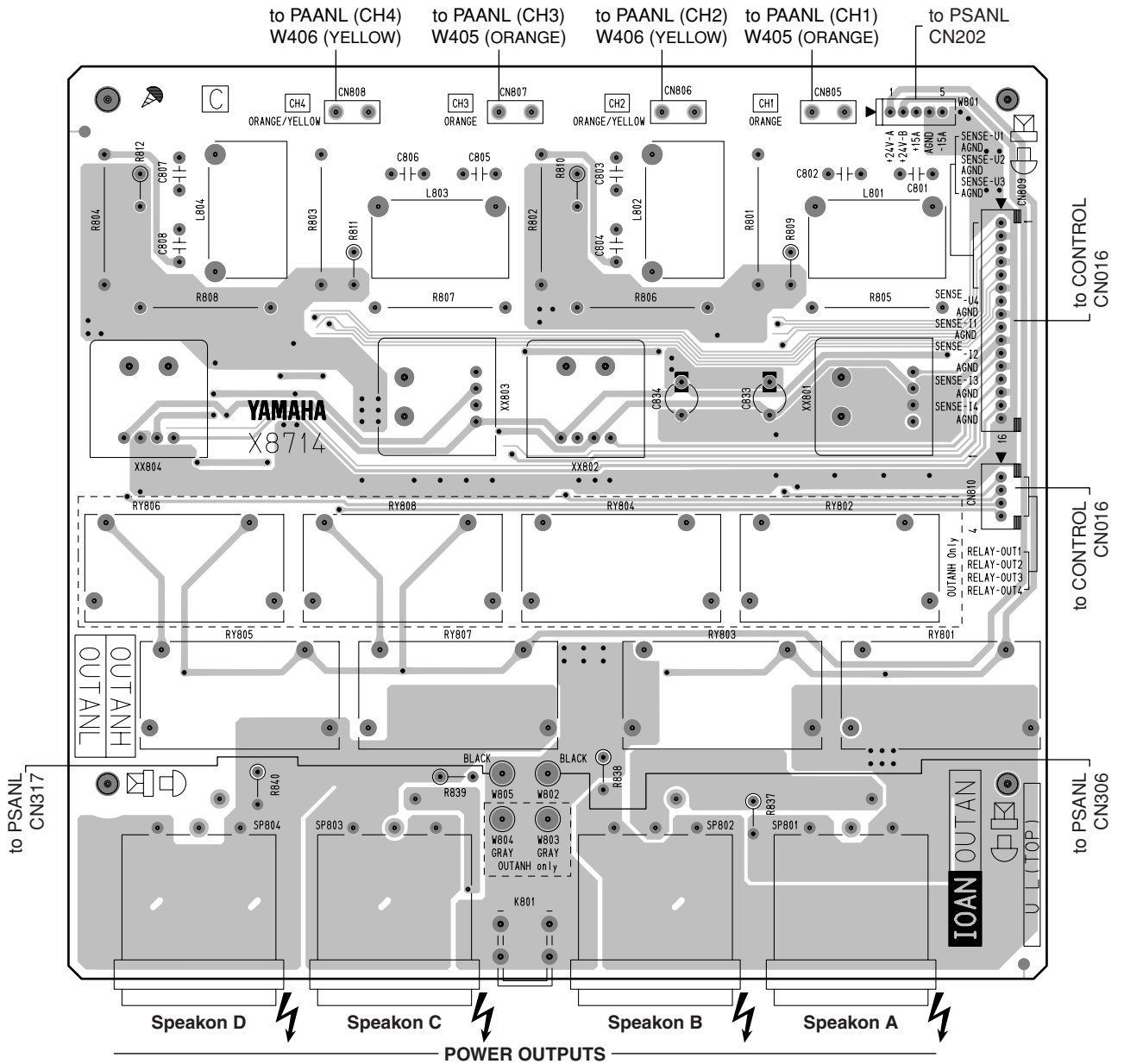

Component side

• OUTANL Circuit Board

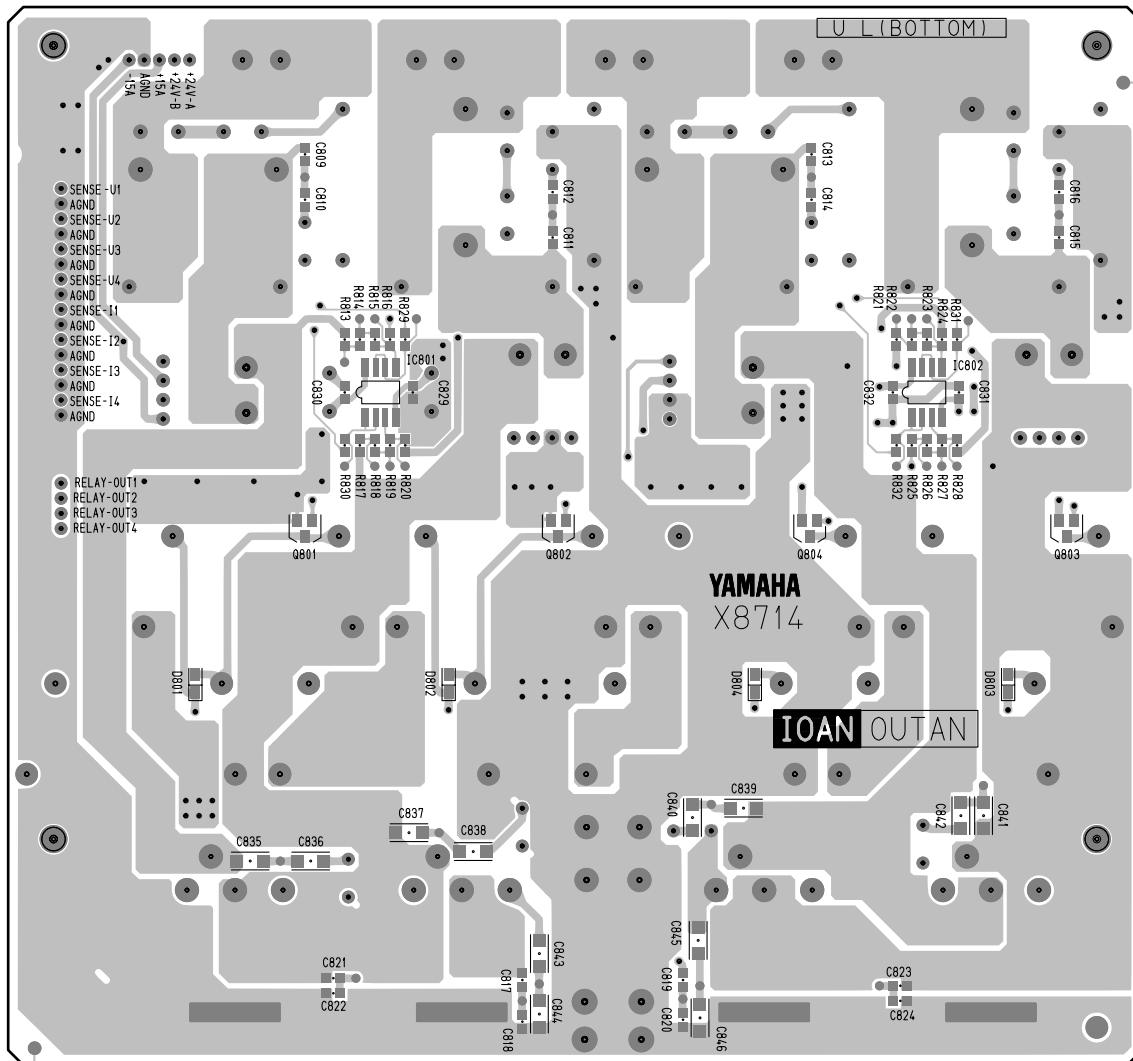

Pattern side

• RS232-GPI Circuit Board

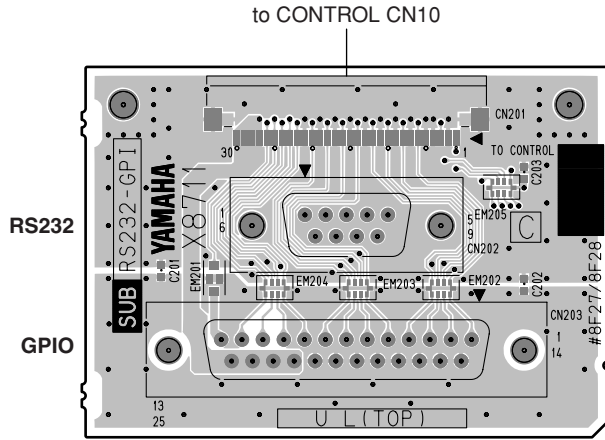

Component side

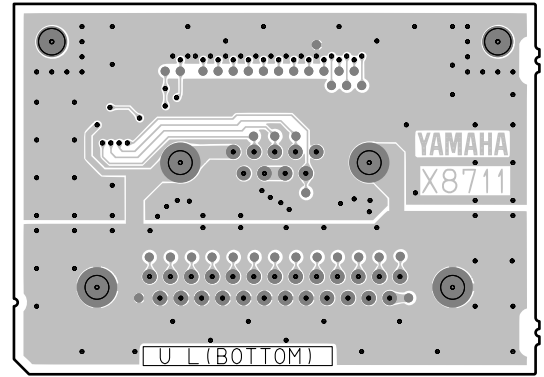

Pattern side

• OPT-AN Circuit Board

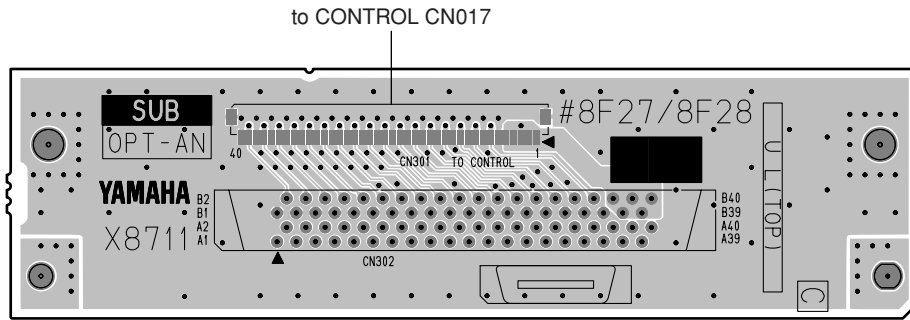

Expansion slot

Component side

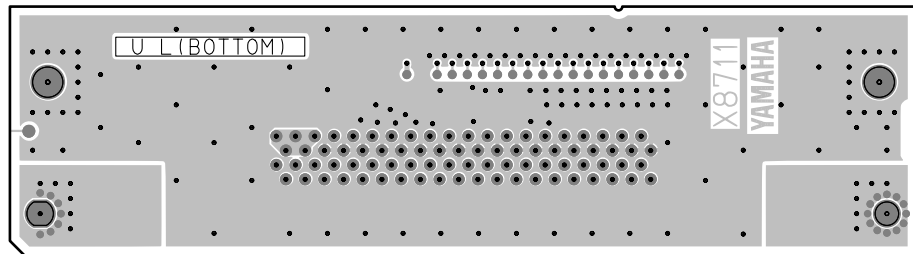

Pattern side

• LCD SPACER Circuit Board

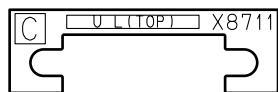

Component side

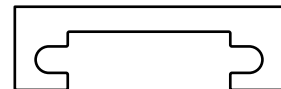

Pattern side

• PN-AN Circuit Board

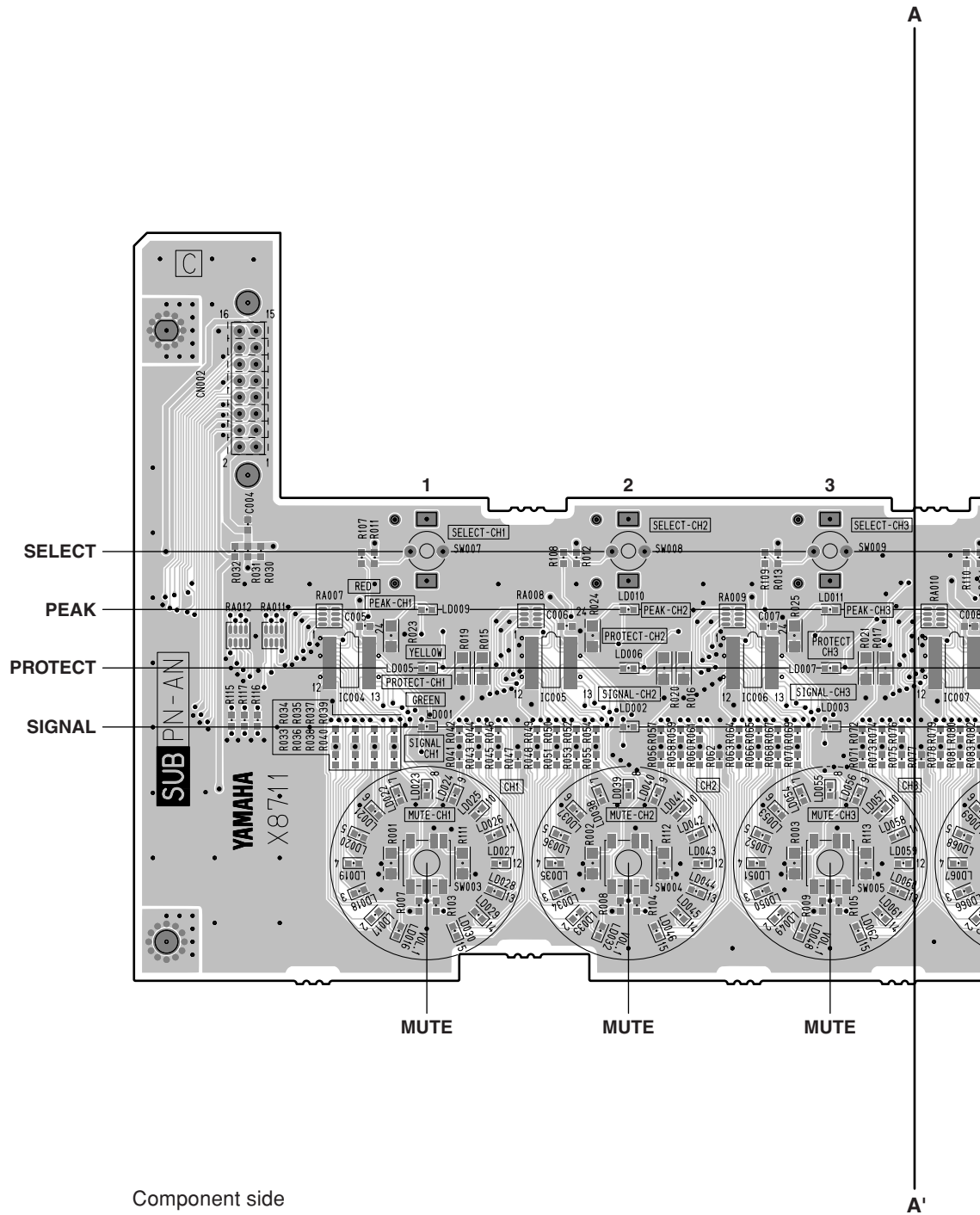

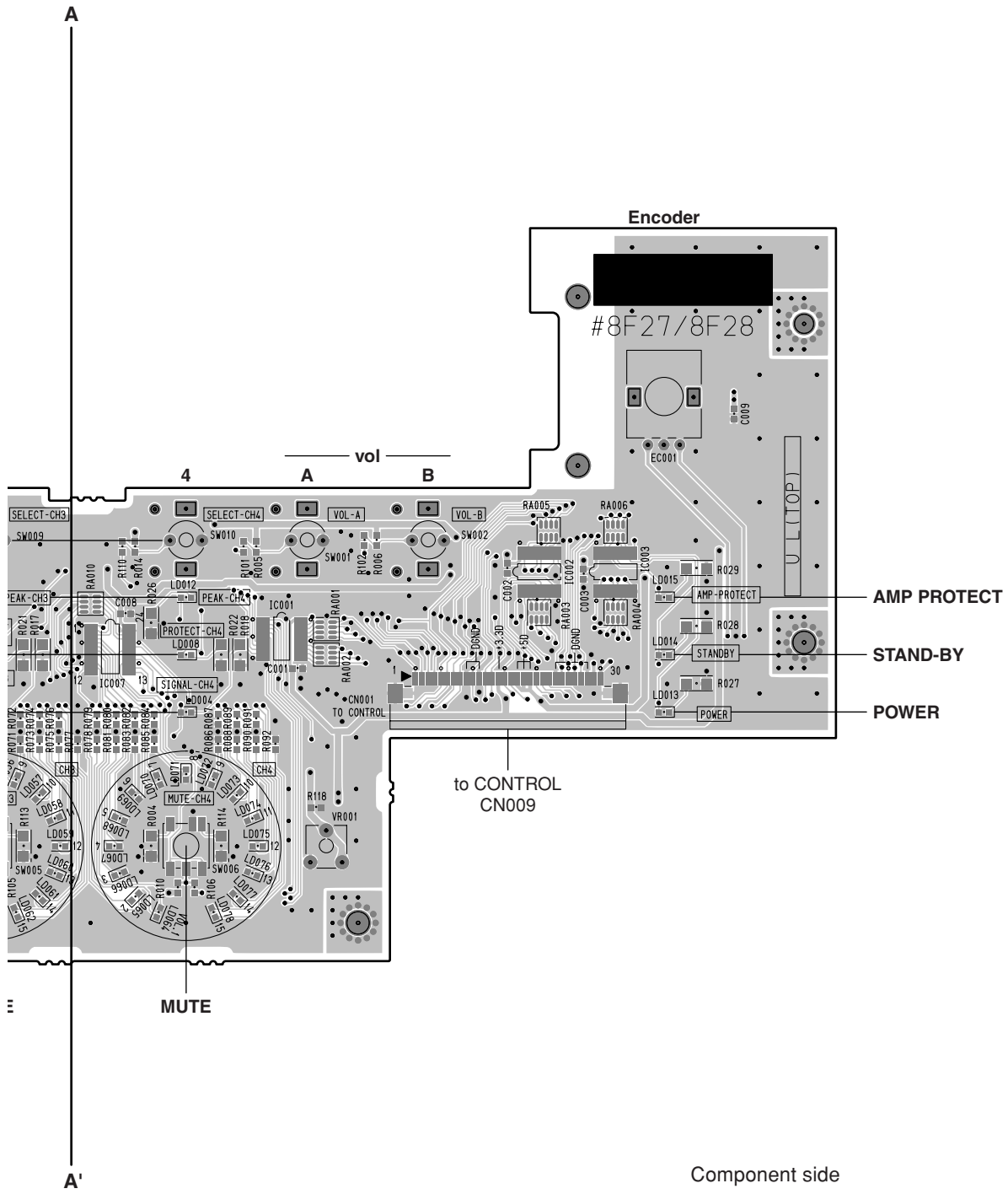

- PN-AN Circuit Board

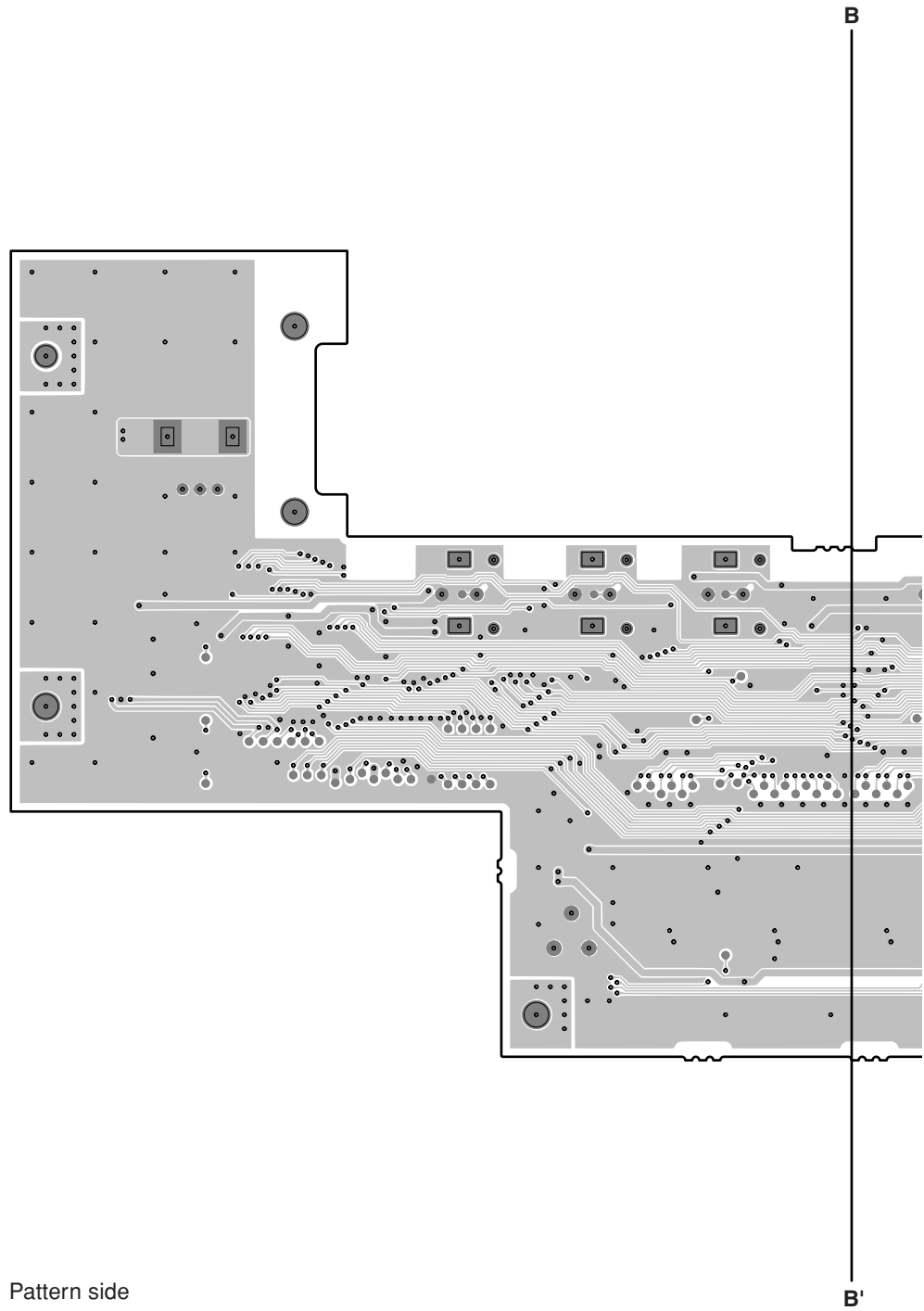

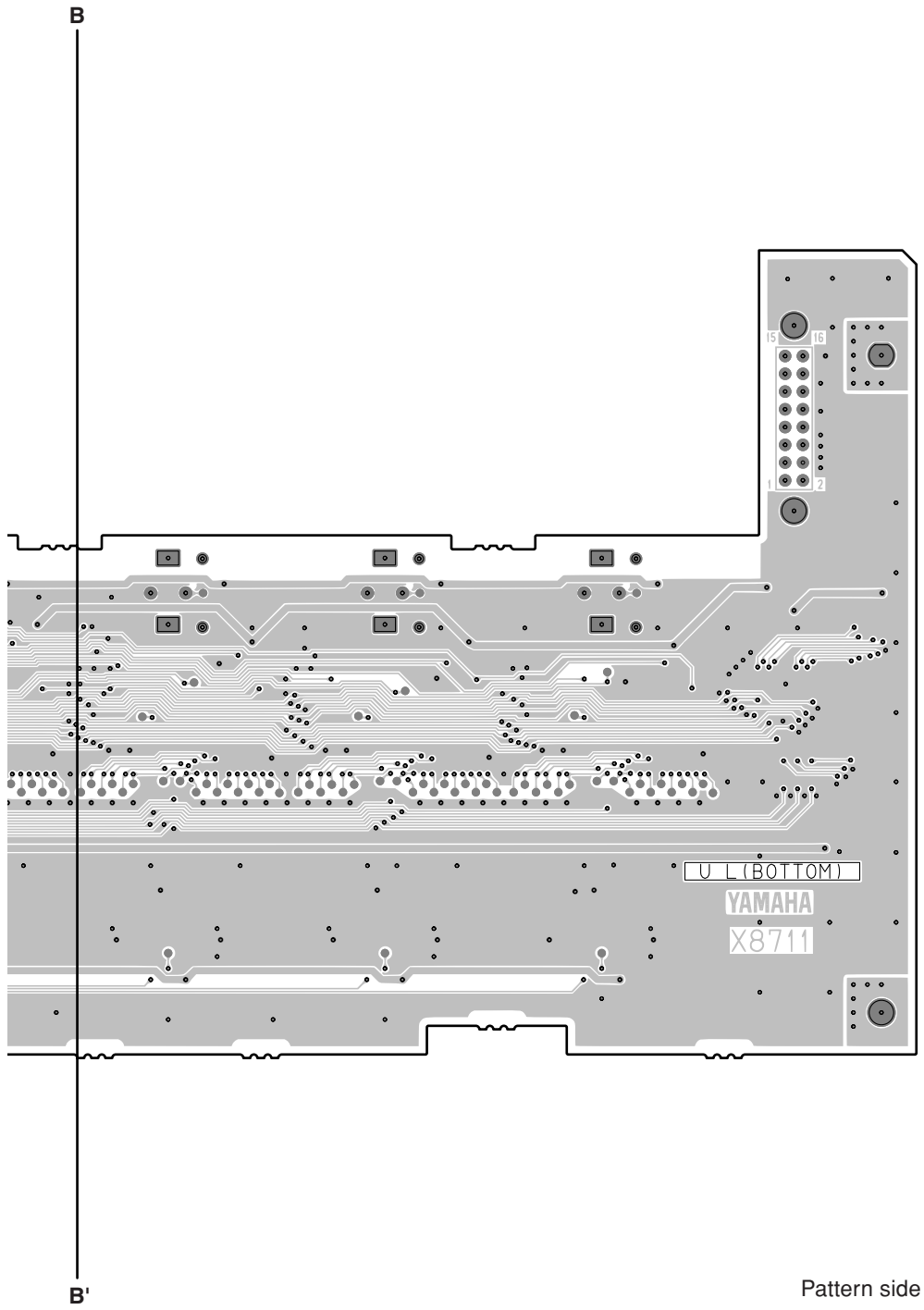

• PAANL Circuit Board

Reduction: 9/10

to CONTROL
CN012, CN014

to OUTANL
CN805, CN807

A

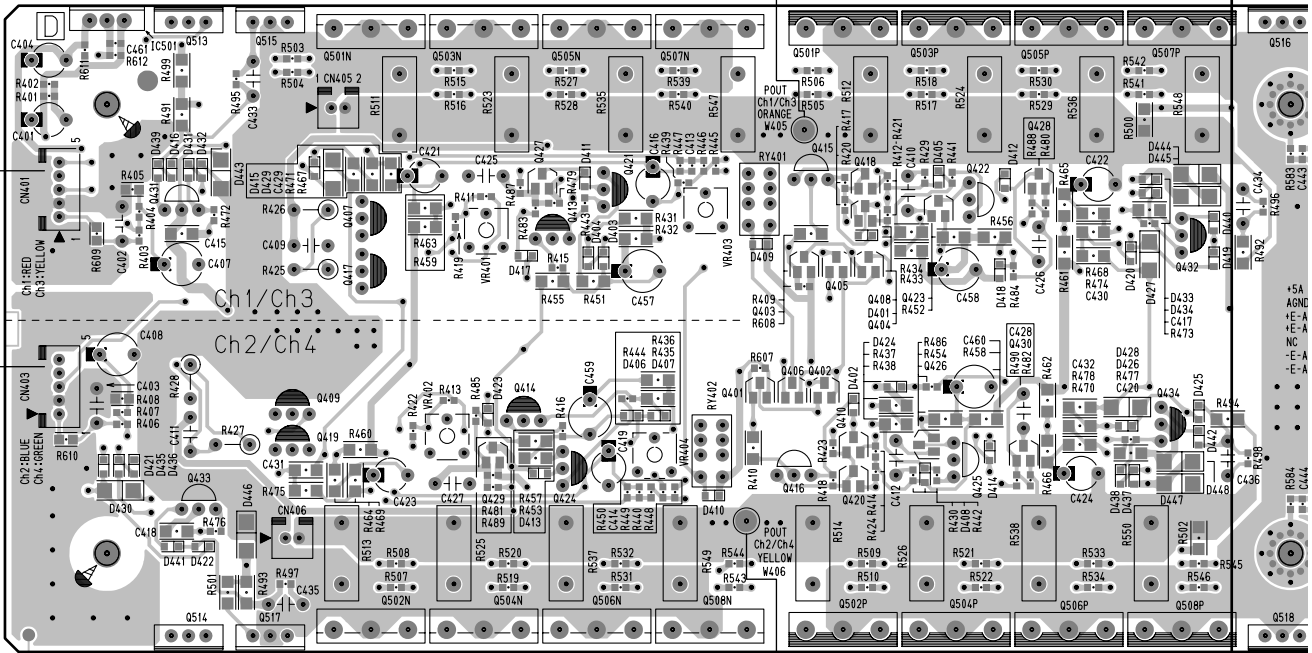

to CONTROL
CN013, CN015

to OUTANL
CN806, CN808

A'

B

Component side

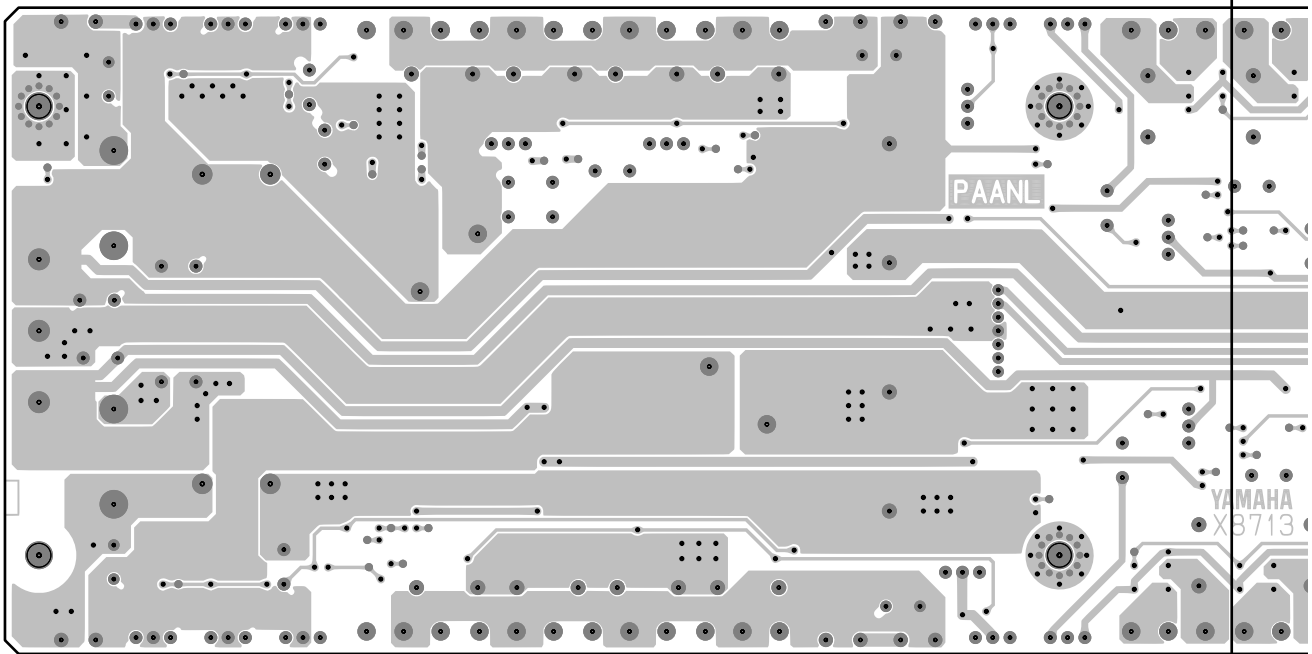

Pattern side

B'

Reduction: 9/10

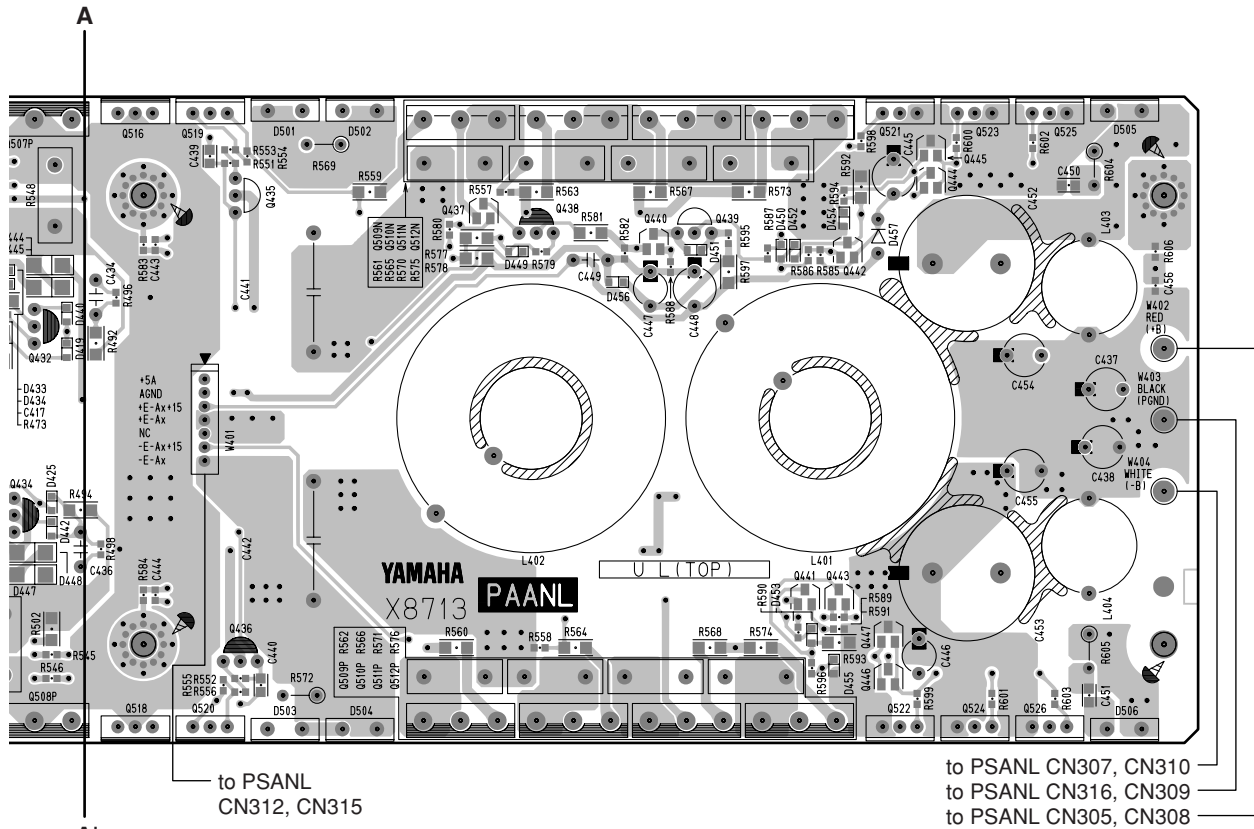

Component side

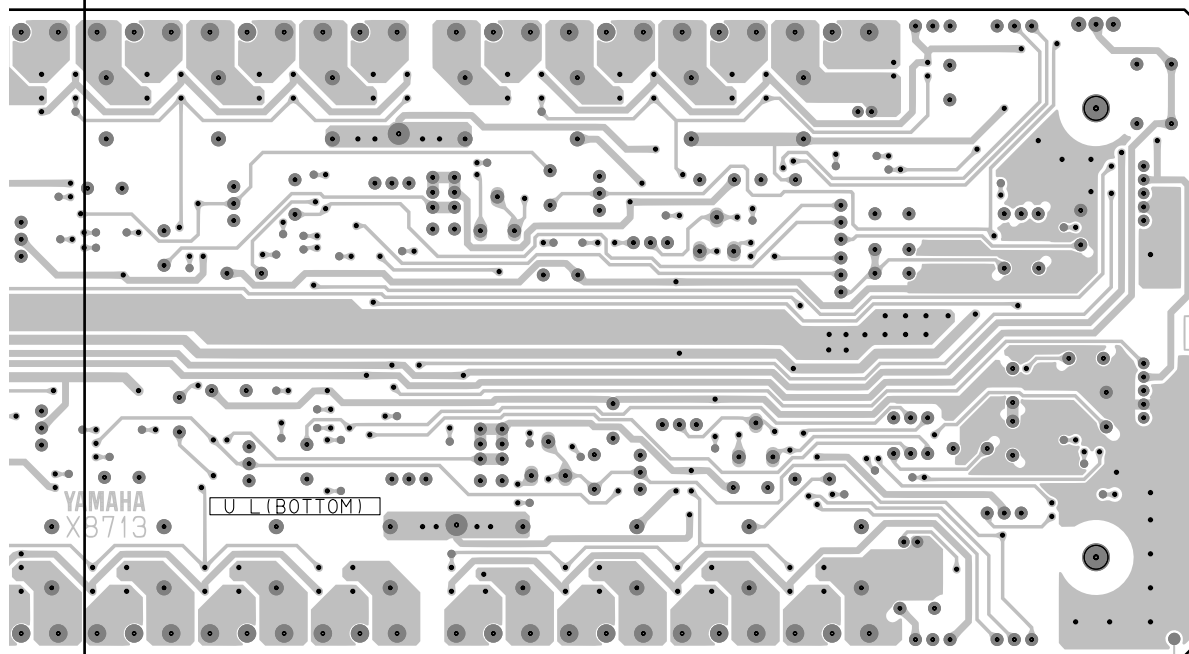

Pattern side

• PSANL Circuit Board

Reduction: 7/10

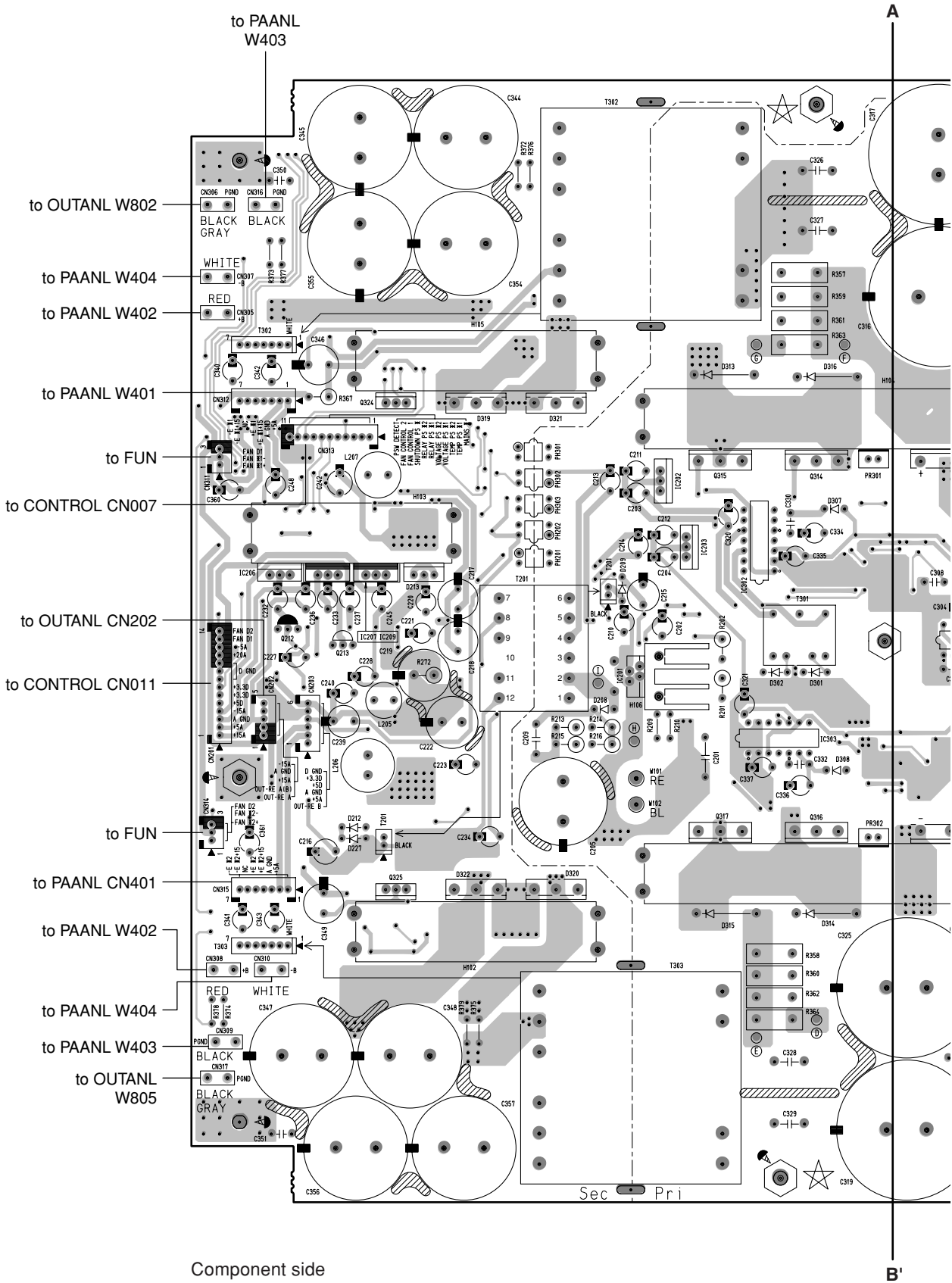

Reduction: 7/10

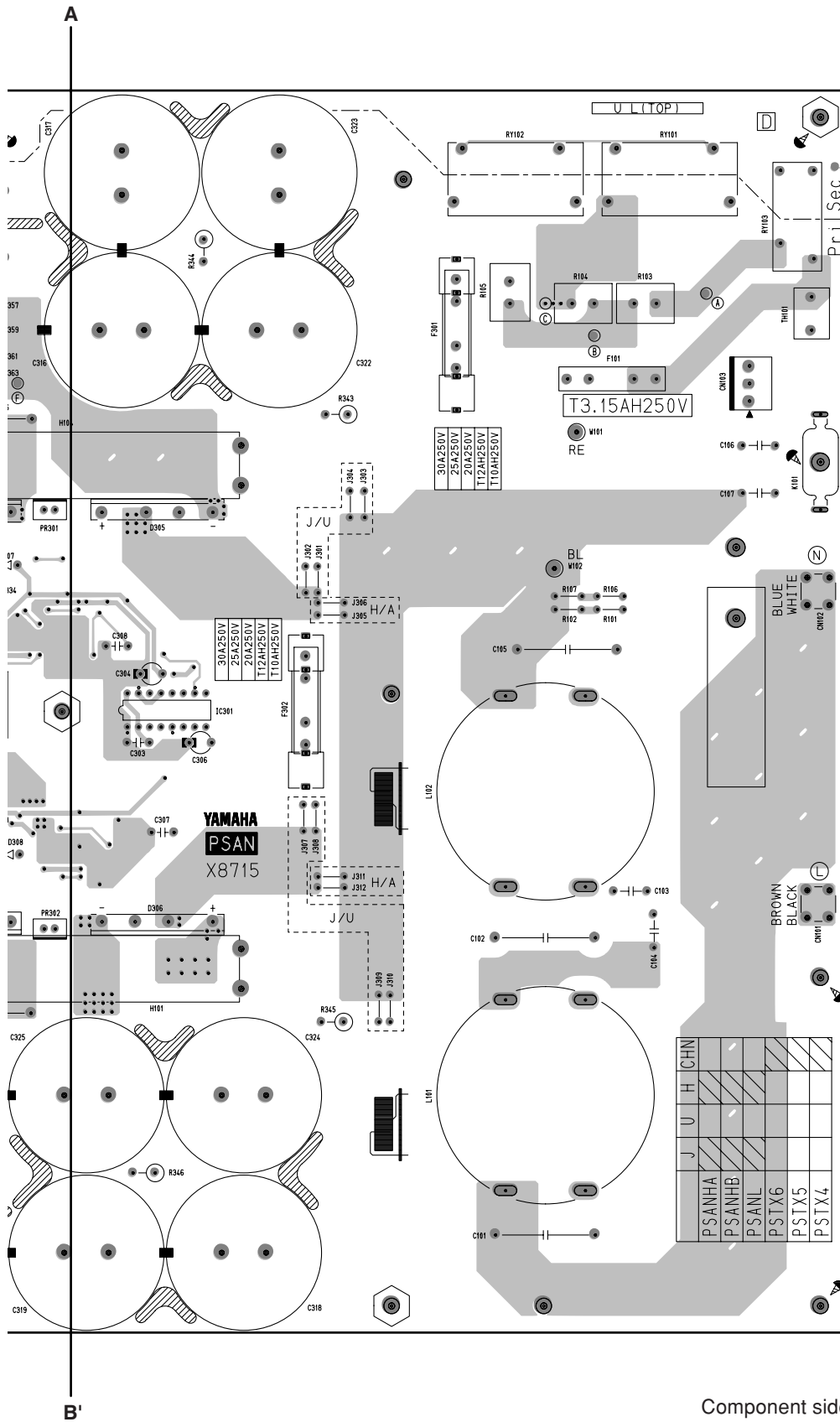

Component side

2NA-WJ97350-50

• PSANL Circuit Board

Reduction: 7/10

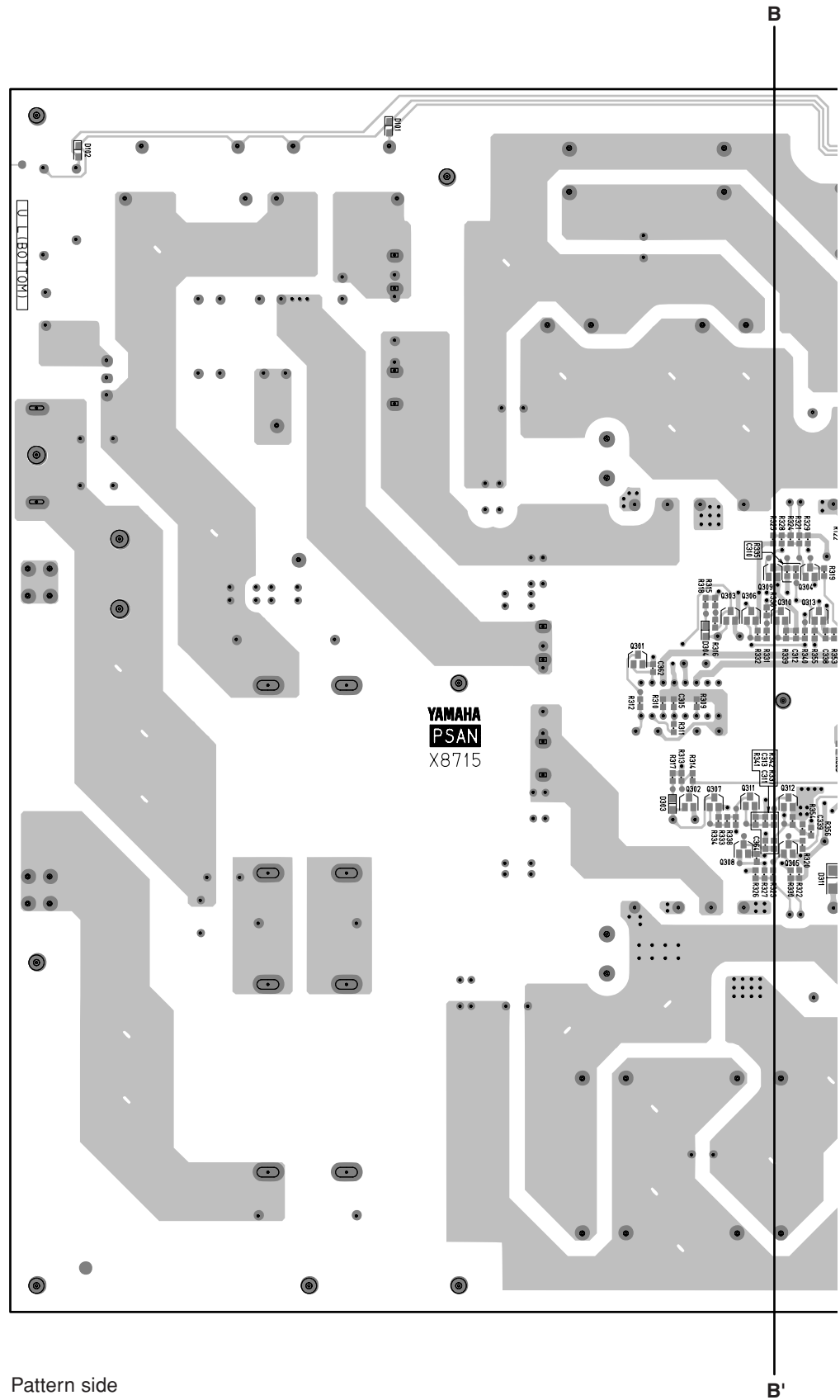

Reduction: 7/10

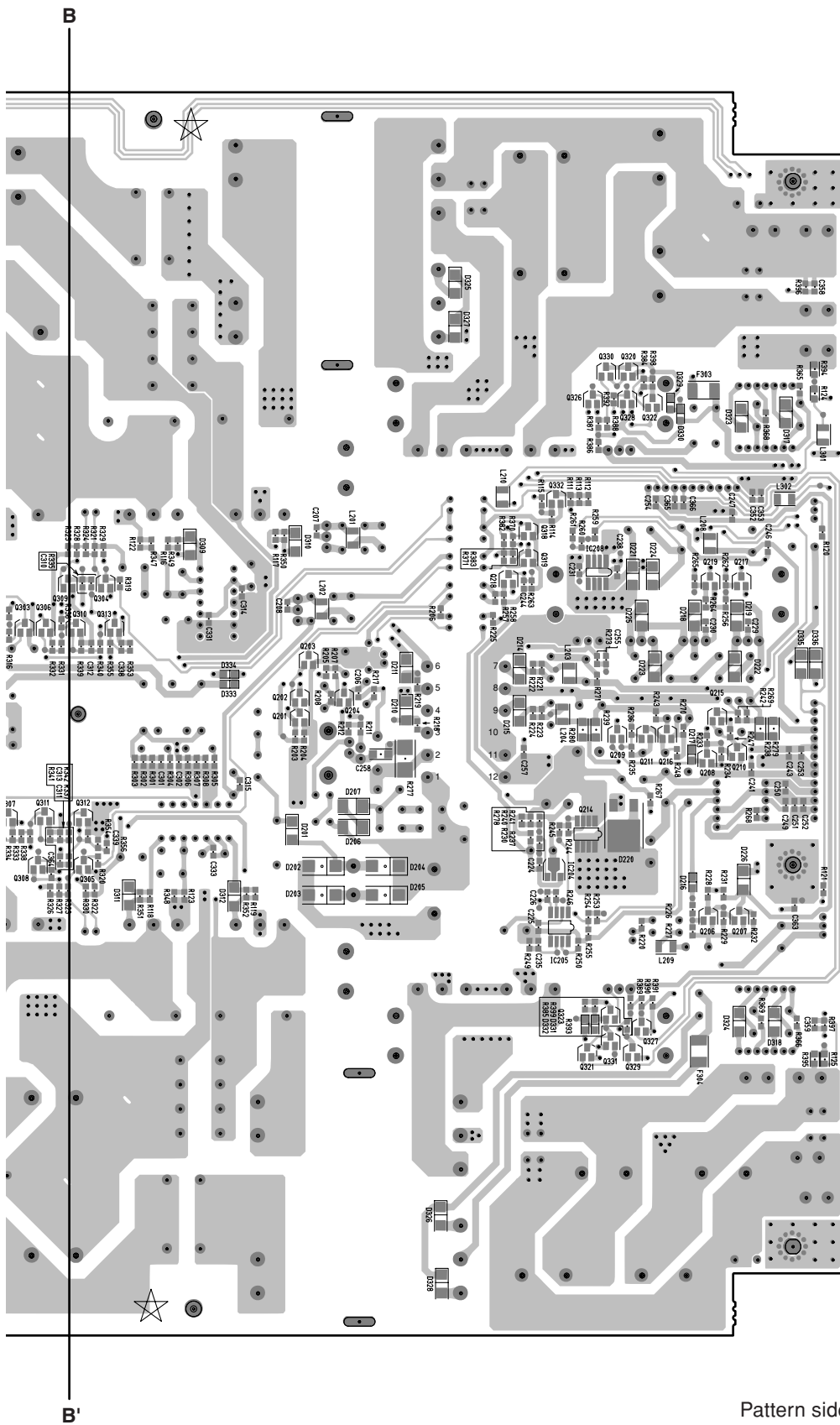

Pattern side

2NA-WJ97350-50

TEST PROGRAM

1. Required items

- Computer : DOS/V computer x1 (Pentium 200MHz or more, Windows XP, USB Port)
- Software : Software for version up (JTAG Programmer)
- Cable : RLINK-ST (USB-JTAG adapter)
- Measuring equipment : Power consumption meter
- Tools : RS-232C jig x1, GPI jig x1, SLOT jig x1

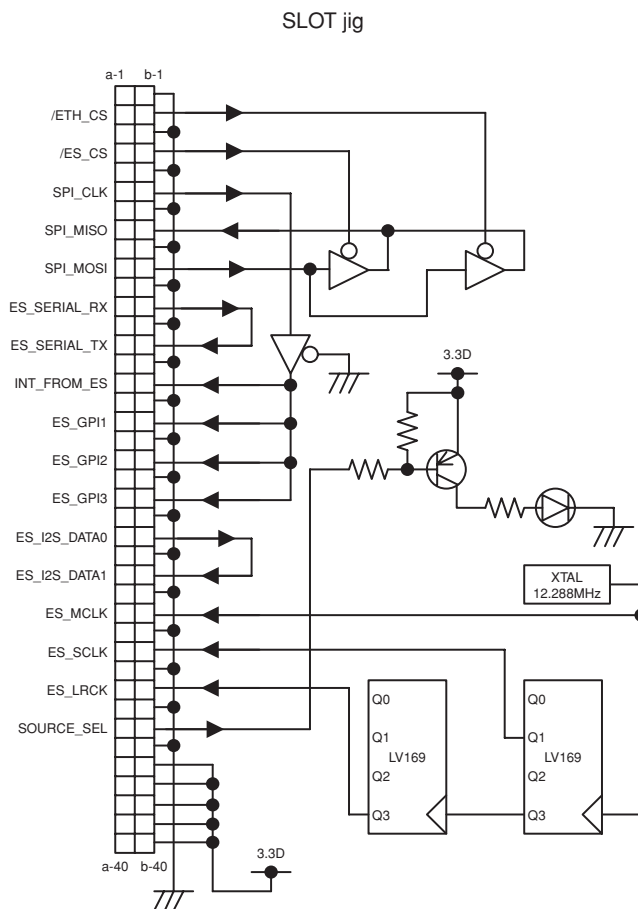
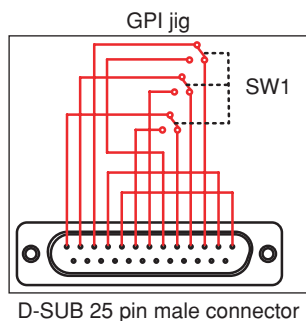
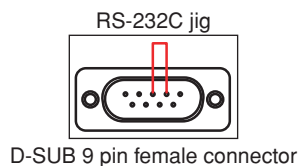

2. Test connection image

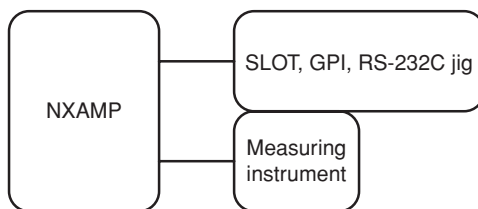

3. Operation

3-1. Entry of the test program

While holding down the [SELECT4], [MUTE4] and [A] buttons simultaneously, turn the power switch on. The start up screen appears on the LCD.

Start Up Screen

```

Boot 1.00
WAIT...
    
```

Then release your fingers from the buttons.

The test program starts and the test menu screen appears on the LCD.

Test Menu Screen

```

00 CHOOSE TEST < >
01 SWITCH
    
```

3-2. Executing the test and judgment display

Select the desired test item from the table below using the rotary encoder, and press the [B] button to start the test.

Test Program List

01	SWITCH	11	FLASH
02	ENCODER	12	FAN
03	LED	13	SLOT
04	LCD	14	ATTENUATION
05	RS232	15	ANALOG
06	GPI	16	BRIDGE
07	PORT (no use)	17	CALIBRATION
08	DSP	18	STANDBY
09	WORD CLOCK	19	QUIT
10	12C		

After executing the test, the display returns to the test menu screen if the test result is OK. If an error occurs, "ERROR" appears on the LCD and the test program is stopped. In this case, turn the power switch off and on again as was done above in 3-1.

4. Outline of tests

4-1. SWITCH test

```

00 CHOOSE TEST < >
01 SWITCH
    
```

Press the [B] button to start the test. The LCD shows one by one the switch name to be tested as shown below.

```

01 SWITCH
HIT SELECT CH1
    
```

Press the switch displayed on the LCD as instructed. If all instructed switches are OK, the display automatically returns to the test menu screen.

4-2. ENCODER test

```

00 CHOOSE TEST < >
02 ENCODER
    
```

Press the [B] button to start the test, and the following display appears.

```

02 ENCODER
TURN RIGHT 0
    
```

Turn the ENCODER knob clockwise. The 2nd line on the display changes as shown below.

TURN RIGHT 0 →.....→ TURN RIGHT 19

The following display appears after the 2nd line on the display reaches TURN RIGHT 19.

```

02 ENCODER
TURN LEFT 0
    
```

Turn the ENCODER knob counterclockwise. The 2nd line on the display changes as shown below.

TURN LEFT 0 →.....→ TURN LEFT 19

The display returns to the test menu screen after the 2nd line on the display reaches TURN LEFT 19.

4-3. LED test

```

00 CHOOSE TEST < >
03 LED
    
```

Press the [B] button to start the test, and the following display appears.

```

03 LED
    
```

The LEDs automatically light up one by one in a specific order as shown on the next page.

All LEDs will light at the same time after each LED individually has been tested. Confirm that each LED is lit normally. If OK, press the [B] button to return the display to the test menu screen.

Lighting order

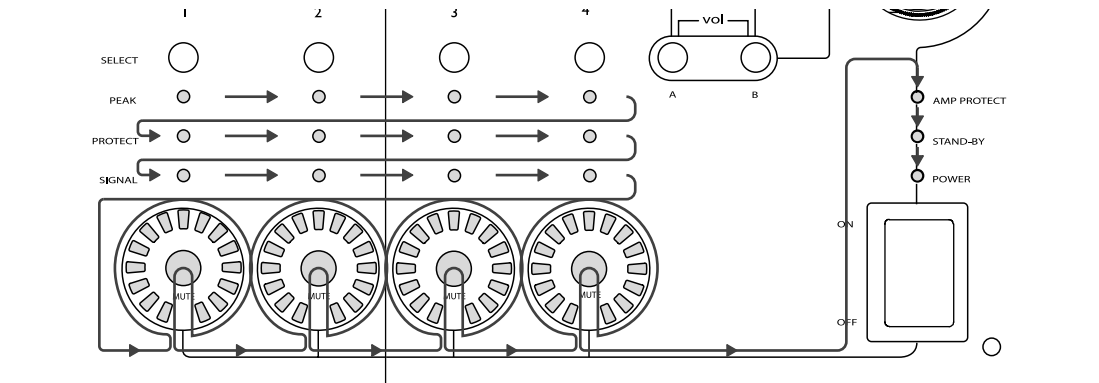

4-4. LCD test

```
00 CHOOSE TEST < >
04 LCD
```

Press the [B] button to start the test. First the following display appears.

```
04 LCD
```

All the dots of the LCD go on and off two times. Finally, all the dots of the LCD are lit. Confirm that all the dots of the LCD have lit normally. If OK, press the [B] button to return the display to the test menu screen.

4-5. RS-232C test

```
00 CHOOSE TEST < >
05 RS-232C
```

Connect the RS-232C jig to the R232C port of the NXAMP4x1.

Then press the [B] button to start the test, and the following display appears.

```
05 RS-232C
RS-232C OK ?
```

Press the [B] button to continue the test. The test executes automatically.

After executing the test, the following display appears. (When an error occurs, the “ERROR” appears and the test program is stopped.)

```
05 RS-232C
RELEASE RS-232C
```

Disconnect the RS-232C jig from the RC232C port. Press the [B] button to return the display to the test menu screen.

4-6. GPI test

```
00 CHOOSE TEST < >
06 GPI
```

Connect the GPI jig to the GPIO port of the NXAMP4x1. Then press the [B] button to start the test, and the following display appears.

```
06 GPI
GPO[0:4] TEST OK ?
```

Switch the GPI jig to the GPO [0:4] position and press the [B] button to continue the test.

The test executes automatically.

If normal, the following display appears. (If an error occurs, “ERROR” appears and the test program is stopped.)

```
06 GPI
GPO[5:7] TEST OK ?
```

Switch the GPI jig to the GPO [5:7] position. Press the [B] button to continue the test.

The test executes automatically. If the test result is OK, the display automatically returns to the test menu screen. (If an error occurs, "ERROR" appears and the test program is stopped.)

Disconnect the GPI jig from the GPIO port.

4-7. PORT test

Test for factory inspection only.

4-8. DSP test

```
00 CHOOSE TEST < >
08 DSP
```

Press the [B] button to start test. The following display appears.

```
08 DSP
CPU to DSP TEST OK ?
```

Press the [B] button to continue the test. The test executes automatically.

If normal, the following display appears.

```
08 DSP
DSP to DSP TEST OK ?
```

Press the [B] button to continue the test. The test executes automatically.

If the test result is OK, the display automatically returns to the test menu screen.

(If an error occurs, "ERROR" appears and the test program is stopped.)

4-9. WORD CLOCK test

```
00 CHOOSE TEST < >
09 WORD CLOCK
```

Press the [B] button to start the test. The following display appears.

```
09 WORD CLOCK
LRCK 48k TEST OK ?
```

Press the [B] button to continue the test. The test is executed automatically.

If normal, the following display appears.

```
09 WORD CLOCK
LRCK 96k TEST OK ?
```

Press the [B] button to continue the test. The test is executed automatically.

If the test result is OK, the display automatically returns to the test menu screen.

(If an error occurs, "ERROR" appears and the test program is stopped.)

4-10. 12C test

```
00 CHOOSE TEST < >
10 12C
```

Press the [B] button to start the test. The following display appears.

```
10 12C
12C TEST OK ?
```

Press the [B] button to continue the test. The test executes automatically.

If the test result is OK, the display automatically returns to the test menu screen.

(If an error occurs, "ERROR" appears and the test program is stopped.)

4-11. FLASH test

```
00 CHOOSE TEST < >
11 FLASH
```

Press the [B] button to start the test. The following display appears.

```
11 FLASH
FLASH TEST OK ?
```

Press the [B] button to continue the test. The test executes automatically.

If the test result is OK, the display automatically returns to the test menu screen.
(If an error occurs, "ERROR" appears and the test program is stopped.)

4-12. FAN test

```
00 CHOOSE TEST < >
12 FAN
```

Press the [B] button to start the test. The following display appears.
The FAN starts rotating at low speed.

```
12 FAN
LOW
```

Check that the FAN rotates at low speed, and press the [B] button to continue the test. The following display appears, and the FAN rotates at middle speed.

```
12 FAN
MIDD
```

Check that the FAN rotates at middle speed, and press the [B] button to continue the test. The following display appears, and the FAN rotates at high speed.

```
12 FAN
HIGH
```

Check that the FAN rotates at high speed, and press the [B] button to return the display to the test menu screen.

4-13. SLOT test

```
00 CHOOSE TEST < >
13 SLOT
```

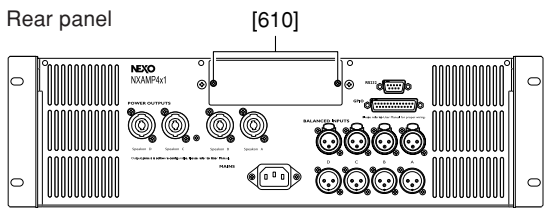

(Remove the [610] plate on the rear panel of the NXAMP4x1, and insert the SLOT jig into the expansion slot.)

Press the [B] button to start the test. The test executes automatically.

If every signal is normal, the following display appears and the LED of the SLOT jig lights.

(If an error occurs, "ERROR" appears and the test program is stopped.)

```
13 SLOT
ANALOG TEST OK ?
```

Input the 1 kHz, -10 ± 1 dBu sine wave to the channel 1 input terminal and confirm that the output voltage obtained at the channel 1 output terminal is $+19.1 \pm 2.0$ dBu.

If OK, press the [B] button to return the display to the test menu screen.

4-14. ATTENUATION test

```
00 CHOOSE TEST < >
14 ATTENUATION
```

Press the [B] button to enter the attenuation test mode. The following display appears.

```
14 ATTENUATION
NOISE TEST OK ?
```

Perform the test according to the "Inspection with attenuation test mode". (See page 60).

If OK, press the [B] button to return the display to the test menu screen.

4-15. ANALOG test

```
00 CHOOSE TEST < >
15 ANALOG
```

Press the [B] button to enter the analog test mode. The following display appears.

```
15 ANALOG
ANALOG TEST OK ?
```

Perform the test according to the “Inspection with analog test mode”. (See page 61, 62).

Press the [B] button. The following display appears.

```
15 ANALOG
MUTE TEST OK ?
```

If OK, press the [B] button to return the display to the test menu screen.

4-16. BRIDGE test

```
00 CHOOSE TEST < >
16 BRIDGE
```

Press the [B] button to enter the bridge test mode. The following display appears.

```
16 BRIDGE
ANALOG TEST OK ?
```

Perform the test according to the “Inspection with BRIDGE mode”. (See page 63).

If OK, press the [B] button to return the display to the test menu screen.

4-17. CALIBRATION

```
00 CHOOSE TEST < >
17 CALIBRATION
```

Press the [B] button to start the calibration. The following display appears.

```
17 CALIBRATION
CH1 INPUT SIGNAL OK ?
```

Input the 1 kHz, +10 dBu sine wave to the channel 1 input terminal, and press the [B] button. The analog input level is automatically calibrated, and the following display appears.

```
17 CALIBRATION
CH2 INPUT SIGNAL OK ?
```

Input the 1 kHz, +10 dBu sine wave to the channel 2 input terminal, and press the [B] button. The analog input level is automatically calibrated, and the following display appears.

```
17 CALIBRATION
CH3 INPUT SIGNAL OK ?
```

Input the 1 kHz, +10 dBu sine wave to the channel 3 input terminal, and press the [B] button. The analog input level is automatically calibrated, and the following display appears.

```
17 CALIBRATION
CH4 INPUT SIGNAL OK ?
```

Input the 1 kHz, +10 dBu sine wave to the channel 4 input terminal, and press the [B] button. The analog input level is automatically calibrated, and the following display appears.

```
17 CALIBRATION
CH1 SET TO 39.1 dBu ?
```

Input the 1 kHz, +10 dBu sine wave to the channel 1 input terminal.

Adjust the ENCODER so that the output voltage obtained at the channel 1 output terminal is +39.1 dBu, and press the [B] button.

The analog output level is automatically calibrated, and the following display appears.

```
17 CALIBRATION
CH2 SET TO 39.1 dBu ?
```

Input the 1 kHz, +10 dBu sine wave to the channel 2 input terminal.

Adjust the ENCODER so that the output voltage obtained at the channel 2 output terminal is +39.1 dBu, and press the [B] button.

The analog output level is automatically calibrated, and the following display appears.

```
17 CALIBRATION
CH3 SET TO 39.1 dBu ?
```

Input the 1 kHz, +10 dBu sine wave to the channel 3 input terminal.

Adjust the ENCODER so that the output voltage obtained at the channel 3 output terminal is +39.1 dBu, and press the [B] button.

The analog output level is automatically calibrated, and the following display appears.

```
17 CALIBRATION
CH4 SET TO 39.1 dBu ?
```

Input the 1 kHz, +10 dBu sine wave to the channel 4 input terminal.

Adjust the ENCODER so that the output voltage obtained at the channel 4 output terminal is +39.1 dBu, and press the [B] button.

The analog output level is automatically calibrated, and the following display appears.

```
17 CALIBRATION
CH1 OUTPUT SIGNAL OK ?
```

Adjust the input signal voltage so that the output voltage obtained at the channel 1 output terminal is 24 Vrms (= +29.8 dBu), and press the [B] button.

The output voltage monitor is automatically calibrated, and the following display appears.

```
17 CALIBRATION
CH2 OUTPUT SIGNAL OK ?
```

Adjust the input signal voltage so that the output voltage obtained at the channel 2 output terminal is 24 Vrms (= +29.8 dBu), and press the [B] button.

The output voltage monitor is automatically calibrated, and the following display appears.

```
17 CALIBRATION
CH3 OUTPUT SIGNAL OK ?
```

Adjust the input signal voltage so that the output voltage obtained at the channel 3 output terminal is 24 Vrms (= +29.8 dBu), and press the [B] button.

The output voltage monitor is automatically calibrated, and the following display appears.

```
17 CALIBRATION
CH4 OUTPUT SIGNAL OK ?
```

Adjust the input signal voltage so that the output voltage obtained at the channel 4 output terminal is 24 Vrms (= +29.8 dBu), and press the [B] button.

The output voltage monitor is automatically calibrated, and the following display appears.

```
17 CALIBRATION
CH1 CONNECT 8 OHM LOAD
```

Connect the 8 ohms resistor to the channel 1 output terminal.

Adjust the input signal voltage so that the output voltage obtained at the channel 1 output terminal is 24 Vrms (= +29.8 dBu), and press the [B] button.

The output current monitor is automatically calibrated, and the following display appears.

```
17 CALIBRATION
CH2 CONNECT 8 OHM LOAD
```

Connect the 8 ohms resistor to the channel 2 output terminal.

Adjust the input signal voltage so that the output voltage obtained at the channel 2 output terminal is 24 Vrms (= +29.8 dBu), and press the [B] button.

The output current monitor is automatically calibrated, and the following display appears.

```
17 CALIBRATION
CH3 CONNECT 8 OHM LOAD
```

Connect the 8 ohms resistor to the channel 3 output terminal.

Adjust the input signal voltage so that the output voltage obtained at the channel 3 output terminal is 24 Vrms (= +29.8 dBu), and press the [B] button.

The output current monitor is automatically calibrated, and the following display appears.

```
17 CALIBRATION
CH4 CONNECT 8 OHM LOAD
```

Connect the 8 ohms resistor to the channel 4 output terminal.

Adjust the input signal voltage so that the output voltage obtained at the channel 4 output terminal is 24 Vrms (= +29.8 dBu), and press the [B] button.

The output current monitor is automatically calibrated, and the display returns to the test menu screen.

(If an error occurs, "ERROR" appears and the test program is stopped.)

4-18. STANDBY test

```
00 CHOOSE TEST < >
18 STANDBY
```

Press the [B] button to enter the standby mode, and the following display appears.

```
18 STANDBY
```

Measure the primary power consumption, and check that the measured value is 23 W or less. Press the [B] button for one second or more, and the display returns to the test menu screen.

4-19. QUIT (Exit the test program)

```
00 CHOOSE TEST < >
19 QUIT
```

Press the [B] button to exit the test program, and the NXAMP enters the ordinary mode.

INSPECTIONS

1. Measurement Conditions

1-1. Environment

- Normal temperature: From 10 °C to 35 °C
- Normal humidity: From 45 % to 85 %

1-2. Power Source

- When measuring the electrical characteristics, set the power supply voltage and frequency as specified in the table below.

Destination	Power supply voltage	Frequency
U	120 V +2/-0 %	60 Hz
CHN	230 V +2/-0 %	50 Hz

1-3. Measuring Instruments

- Use a reliable measuring device capable of precisely measuring the specification values indicated in this document.
- Input impedance of the measuring instrument should be more than 1 MΩ.
- The noise level should be measured with a 22 Hz-22 kHz band pass filter.

When you use the Audio Analyzer System made by Audio Precision, Inc. for noise measurement, set the filter characteristics as follows.

BW : 22 Hz-22 kHz
 Filter (Fltr) : None

1-4. Connections

Each input and output terminal of channels 1-4 are as shown in the figure below.

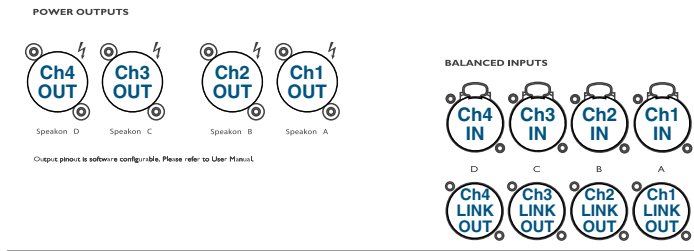

Fig. 1

1-4-1. Input connector

The XLR-3-31 (female) type connectors are used for channel 1-4 input terminals.

Condition : Balanced input
 Wiring : pin 1 to ground, pin 2 to hot (+), pin 3 to cold (-)

1-4-2. Output connector

Neutrik SPEAKON connectors are used for output terminals in channels 1-4.

Connect the load resistor between pin 1+ and pin 1- of the Neutrik SPEAKON connector.

1-4-3. Load resistor

Use a load resistor with no inductivity and a power rating high enough to perform each test safely.

1-4-4. Link out connectors

XLR-3-32 (male) type connectors are used for input terminals in channels 1-4.

Condition : Balanced output
 Wiring : pin 1 to ground, pin 2 to hot (+), pin 3 to cold (-)

1-5. Other

0 dBu is defined as 0.775 Vrms in these inspections.

2. Inspection with ordinary mode

Condition:

- Ground each input terminal via a 600 Ω resistor.
- Do not connect the load resistor to the output terminal.

2-1. Power ON sequence

- 1) Turn the power switch on. Confirm that the latest firmware version appears on the LCD and the four (4) MUTE LEDs light up.

Example of firmware version 1.00

```

-- [v 1.00] --
(c) NEXO 2007.
```

- 2) Confirm that all the fans start rotation at low speed within 4 seconds after turning the power switch on.
- 3) Confirm that the following display appears on the LCD within 18 ± 3 seconds after turning the power switch on. Also confirm that the POWER LED and only one of the VOLUME LEDs for each channel light up.

```

-20.0  -20.0  -20.0  -20.0  Vol(dB)
[MAIN ] [MAIN ] [SUB  ] [SUB  ] <  >
```

2-2. Power consumption when idling

Measure the primary power consumption and confirm that the measured value is 70 ± 20 W.

2-3. Output terminal DC voltage

Measure the DC voltage (Vdc) of each output terminal and confirm that the measured value is $V_{dc} = 0 \pm 50$ mV.

3. Inspection with attenuation test mode

Condition:

- Perform each test in this section in the attenuation test mode. (See page 56)
- Connect a 8 Ω load resistor to each output terminal.
- Ground each input terminal via a 600 Ω resistor.

3-1. Residual noise

Confirm that each output terminal's residual noise level is -65 dBu or less.

4. Inspection with analog test mode

Condition:

- Perform each test item in this section with the analog test mode of the test program. (See page 57)
- Unless otherwise specified, perform the test with a 8 Ω resistor is connected to each output terminal.

4-1. Link out

Input the 1 kHz, -10 dBu sine wave to each input terminal and confirm that the output voltage obtained at each link out terminal is -10 ± 0.5 dBu.

4-2. Efficiency

Input the 1 kHz sine wave to the channel 1 input terminal and confirm that the primary power consumption is 175 ± 10 W when the output voltage obtained at the channel 1 output terminal is +29.2 dBu.

Perform the same test for channels 2-4 in the same manner.

4-3. Gain

Input the 1 kHz, 0 dBu sine wave to each input terminal and confirm that the output voltage obtained at each output terminal is $+29.1 \pm 1.2$ dBu.

4-4. Frequency response

Perform the following test at each channel.

Input the 10 Hz, 1 kHz, 20 kHz, 0 dBu sine wave to the input terminal and one by one measure the output voltage obtained at the output terminal for each frequency.

Confirm that the output voltage at 10 Hz is 0 ± 0.5 dB when compared with the output voltage at 1 kHz (0 dB).

Confirm that the output voltage at 20 kHz is $+0.5 \pm 0.5$ dB when compared with the output voltage at 1 kHz (0 dB).

4-5. Distortion

Input the 1kHz sine wave to each channel input terminal and confirm that the distortion in each channel output terminal is 1.0 % or less when 500 W (with 8 ohms load) output is obtained for each terminal at the same time.

4-6. Maximum output

Connect the 4 ohms 500 W resistor to each output terminal.

Input the BURST signal as shown in fig. 2 to each input terminal and adjust the input signal level so that a V_{burst} voltage of 174 Vp-p (volt peak to peak) is obtained in each channel output terminals.

Measure the last wave of the BURST signal peak to peak by the oscilloscope's MEASURE function. Confirm that the measured voltage is 170 volt or more. (See fig. 2)

Note: Perform the test of all channels at the same time.

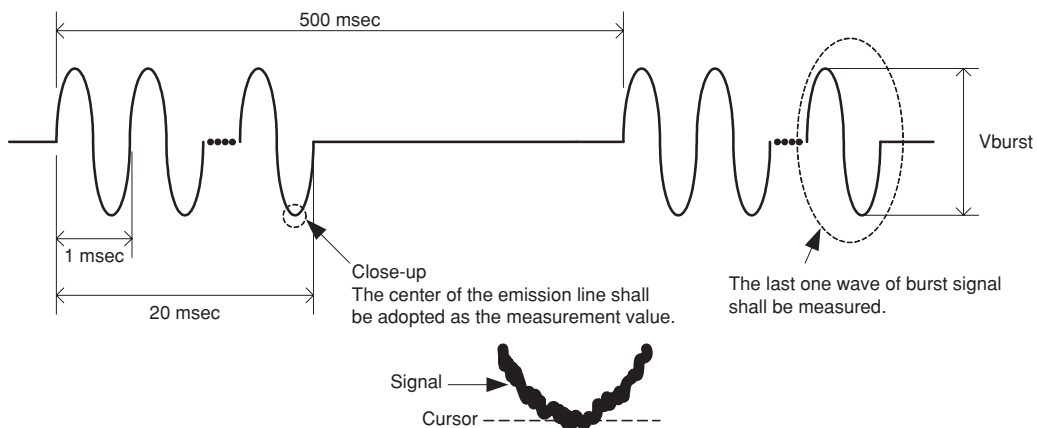

Fig. 2

4-7. Channel separation

- 1) Ground the channel 2, channel 3 and channel 4 input terminals via a 600 Ω resistor.

Input the 1 kHz, 0 dBu sine wave to the channel 1 input terminal and measure the output voltage obtained at the channel 1 output terminal as the reference voltage (0 dB).

Confirm that the output voltage at the channel 2, channel 3 and channel 4 output terminals is -65 dB or less as compared with the reference voltage.

- 2) Ground the channel 1, channel 3 and channel 4 input terminals via a 600 Ω resistor.

Input the 1 kHz, 0 dBu sine wave to the channel 2 input terminal and measure the output voltage obtained at the channel 2 output terminal as the reference voltage (0 dB).

Confirm that the output voltage at the channel 1, channel 3 and channel 4 output terminals is -65 dB or less as compared with the reference voltage.

- 3) Ground the channel 1, channel 2 and channel 4 input terminals via a 600 Ω resistor.

Input the 1 kHz, 0 dBu sine wave to the channel 3 input terminal and measure the output voltage obtained at the channel 3 output terminal as the reference voltage (0 dB).

Confirm that the output voltage at the channel 1, channel 2 and channel 4 output terminals is -65 dB or less as compared with the reference voltage.

- 4) Ground the channel 1, channel 2 and channel 3 input terminals via a 600 Ω resistor.

Input the 1 kHz, 0 dBu sine wave to the channel 4 input terminal and measure the output voltage obtained at the channel 4 output terminal as the reference voltage (0 dB).

Confirm that the output voltage at the channel 1, channel 2 and channel 3 output terminals is -65 dB or less as compared with the reference voltage.

Note: Measure the output level with the 22 Hz-22 kHz band pass filter specified at 1-3.

4-8. Output noise level

With each input terminal grounded via a 600 Ω resistor, measure the noise level in each output terminal and confirm that the measured value is -60 dBu or less.

Note: Measure the noise level with the 22 Hz-22 kHz band pass filter specified at 1-3.

4-9. Stability

With no load resistors connected to all output terminals, input the 1 kHz, -6.0 dBu square wave and measure the primary power consumption (W_{no_load}).

With the 0.1 μ F capacitor connected to all output terminals, input the 1 kHz, -6.0 dBu square wave and measure the primary power consumption (W_{cap_load}).

Confirm that the following equation is satisfied.

$$W_{cap_load} - W_{no_load} = 10 \text{ W or less}$$

5. Inspection with BRIDGE mode

Condition:

- Perform each test item in this section with the bridge test mode of the test program. (See page 57)
- Connect individually the $16\ \Omega$ load resistors to channel 1 and channel 3 output terminals.
- Keep the measurement reference of the measuring instrument in floating condition and connect it to the middle point of each load resistors.
- Do not connect any resistor to channel 2 and channel 4 output terminals.
- The input terminals and output terminals of channel 2 and channel 4 are not used in this section.

5-1. Gain

Input the 1 kHz, 0 dBu sine wave to each input terminal and confirm that the output voltage obtained at each output terminal is $+29.1 \pm 1.2$ dBu.

5-2. Frequency response

Perform the following test at each channel.

Input the 10 Hz, 1 kHz, 20 kHz, 0 dBu sine wave to the input terminal and one by one measure the output voltage obtained at the output terminal for each frequency.

Confirm the output voltage at 10 Hz is 0 ± 0.5 dB when compared with the output voltage at 1 kHz (0 dB).

Confirm the output voltage at 20 kHz is $+0.5 \pm 0.5$ dB when compared with the output voltage at 1 kHz (0 dB).

■ UPDATING THE FIRMWARE

1. Preparation

1-1. Downloading and installing the software for update

- 1) Download http://www.st.com/stonline/products/support/micro/files/standalone_jtag.zip.
- 2) Extract the StandaloneJTAG_1_20.zip.
- 3) Double click the StandaloneJTAG_1_20, and the following install screen appears. (Fig. 1)
- 4) Click the [Finish] button to start installing the software for update.
- 5) Click the [Next] and [Yes] buttons to finish installing.
- 6) Restart the PC after completing the installation.

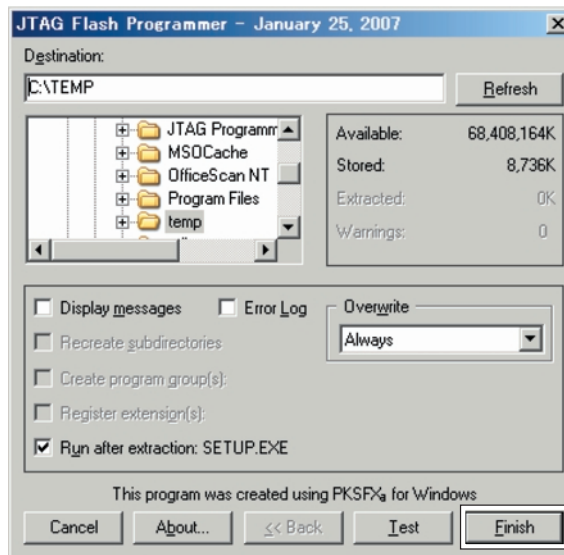

Fig. 1 Install screen

1-2. Connection

Connect the USB port of the PC to the connector CN005 of the CONTROL circuit board installed in the NXAMP4x1 with the USB-JTAG adapter (RLINK-ST).

Note:

When you connect the USB-JTAG adapter (RLINK-ST) for the first time, the USB driver will be required. The USB driver is included in the downloaded file at previous step 1-1. Locate and install the driver.

2. Updating operation

- 1) Turn the power switch of the NXAMP on.
- 2) Start up the installed JTAG Programmer.
- 3) Select new project from the project menu. The following “Create Project” screen appears. (Fig. 2)
- 4) Input the Project Name, Device Family and Device Name as the followings.

Project Name : an (any name may be used)
 Device Family : uPSD3300
 Device Name : uPSD3354DV-40U6

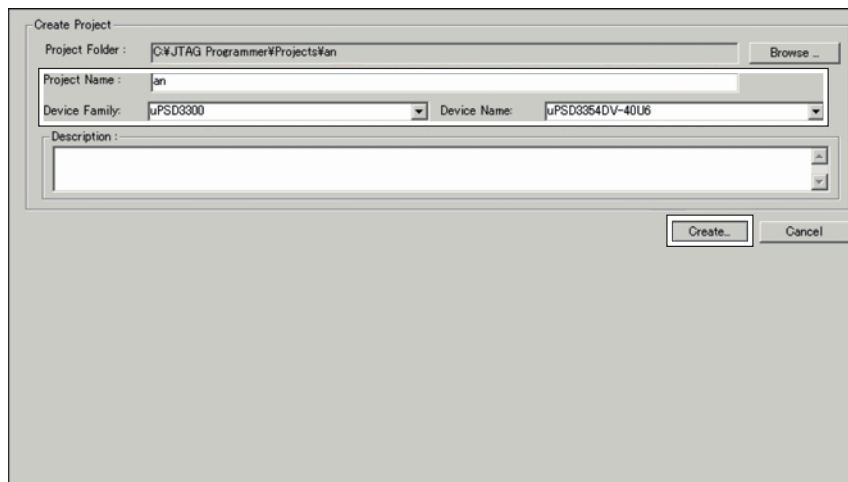

Fig. 2 Create Project screen

- 5) Click the [Create] button, and the following JTAG Programmer screen appears. (Fig. 3)
- 6) Click the [Browse] button to select the desired file.
 Check the [All] at Select region.
 Select Program/Verify at Select operation.

Note:

This operation is needed when you start up for the first time. Click the [Save] button to save the set up file so that this operation will not be required again.

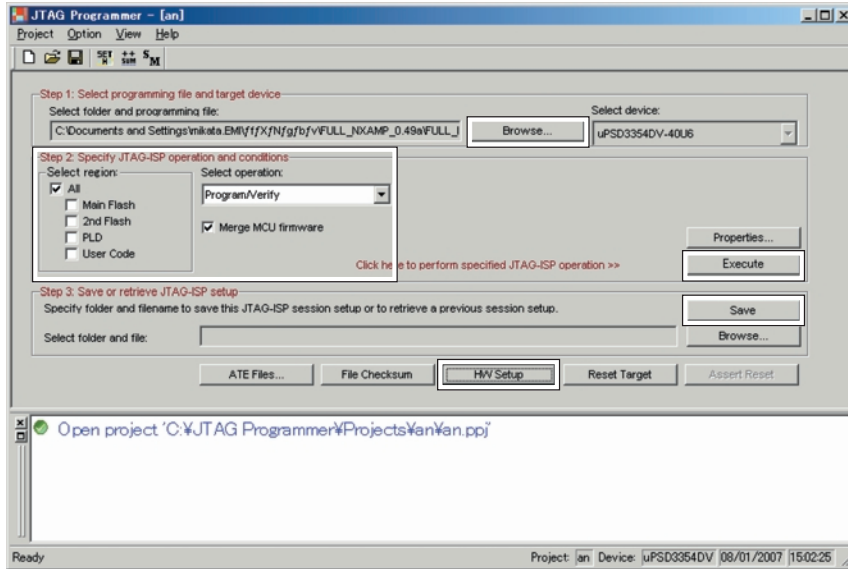

Fig. 3 JTAG Programmer screen

- 7) Click the [HW Setup] button, and the following hardware setting screen appears. (Fig. 4)
- 8) Select the RLink at Hardware selection.

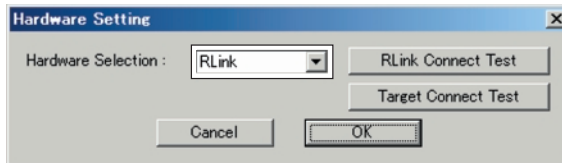

Fig. 4 Hardware Setting screen

- 9) Click the [Execute] button, and the following JTAG-ISP Operations screen appears. (Fig. 5)

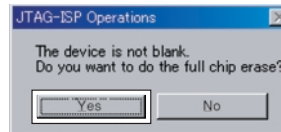

Fig. 5 JTAG-ISP Operations screen

- 10) Click the [Yes] button to start updating the firmware.
- 11) Restart the PC after the completion of the updating.

POWERED TD CONTROLLER

NXAMP4x1

PARTS LIST

■ CONTENTS

OVERALL ASSEMBLY	1/2	2
	2/2	4
PA UNIT		6
LCD ASSEMBLY		8
LOCATIONS OF HEAT SINK UNITS		9
HEAT SINK UNIT L100		10
HEAT SINK UNIT L100		11
HEAT SINK UNIT L60		12
HEAT SINK UNIT L60		13
HEAT SINK UNIT L50		14
HEAT SINK UNIT OSH		15
ELECTRICAL PARTS		16

Notes: DESTINATION ABBREVIATIONS

CHN : Chinese model	U : U.S.A. model
---------------------	------------------

■ WARNING

Components having special characteristics are marked  and must be replaced with parts having specification equal to those originally installed.

- The numbers "QTY" show quantities for each unit.
- The parts with "--" in "PART NO." are not available as spare parts.
- This mark "}" in the REMARKS column means these parts are interchangeable.
- The second letter of the shaded (■) part number is O, not zero.
- The second letter of the shaded (■) part number is I, not one.

OVERALL ASSEMBLY 1/2

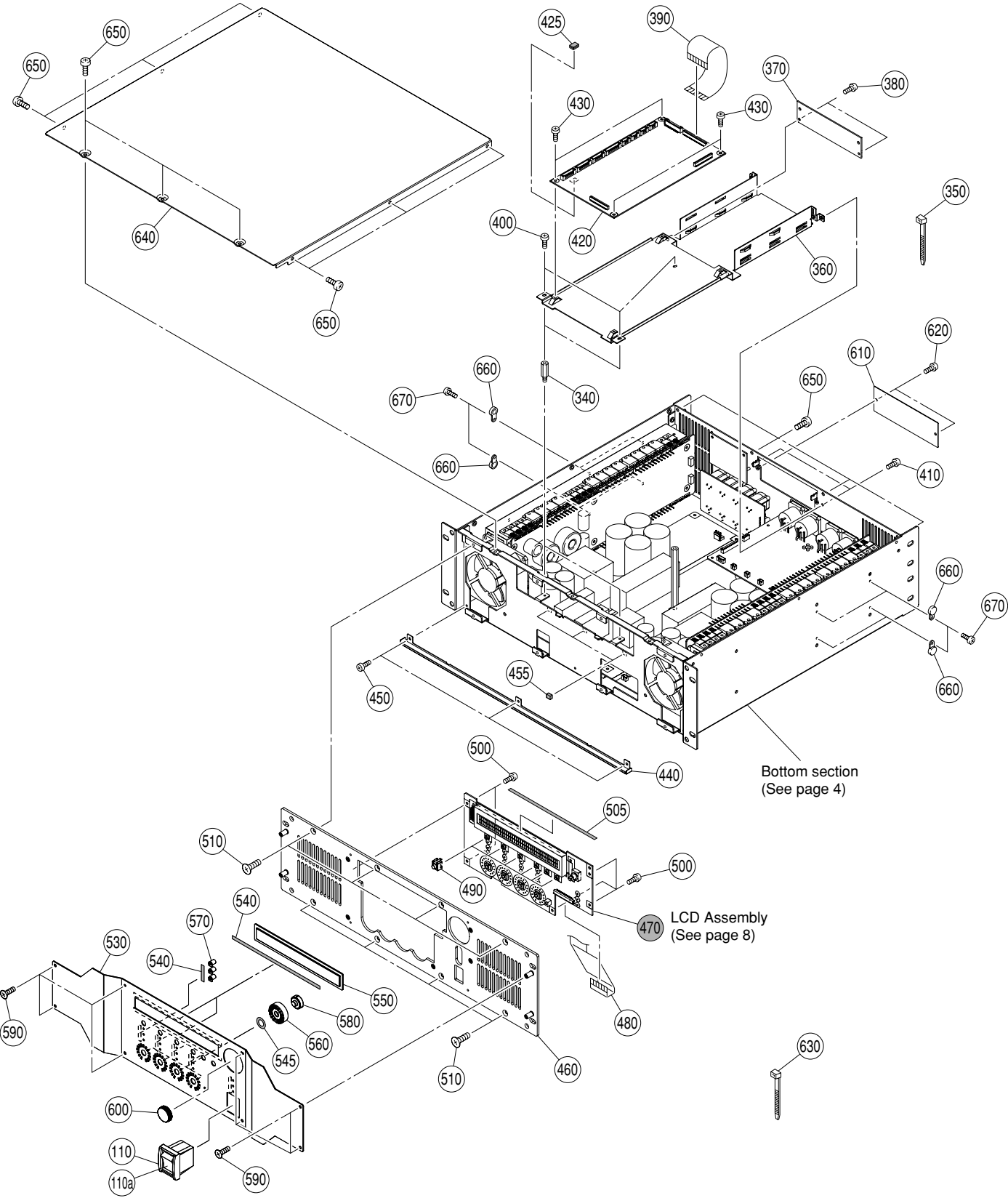

REF NO.	PART NO.	DESCRIPTION	REMARKS	QTY
		OVERALL ASSEMBLY		
	--	Overall Assembly	(WK66600)	
	--	Overall Assembly	CHN (WK66620)	
110	--	Connector Assembly SWPS	POWER (WK94710)	
110a	--	See-Sow Switch	POWER SWITCH (WK75450)	
340	--	Hexagonal Spacer	(WK67210)	2
350	--	Cord Binder	T18R TYTIN CO. (V327280)	9
* 360	WK671500	OPT Angle	AN-PA	
370	--	Circuit Board	OPT-AN (WJ97150)	
380	--	Bind Head Tapping Screw-S	3x6 MFZN2W3 (WE87790)	2
390	--	FFC Cable	SMCD 40P 70mm (WK02120)	
400	--	Bind Head Tapping Screw-S	3x6 MFZN2W3 (WE87790)	3
410	--	Bind Head Tapping Screw-S	3x6 MFZN2B3 (WE87780)	2
* 420	WK044100	Circuit Board	CONTROL	
425	--	Cushion Control	AN-PA (WN15950)	
430	--	Bind Head Tapping Screw-S	3x6 MFZN2W3 (WE87790)	4
440	--	Sub Chassis	AN-PA (WK14900)	
450	--	Bind Head Tapping Screw-S	3x6 MFZN2W3 (WE87790)	3
455	--	Cushion Front	AN-PA (WN19370)	3
* 460	WK670500	Front Panel	AN-PA-LOW	
470	--	LCD Assembly	PA 8F27_8F28 (WK75670)	
480	--	FFC Cable	SMCD 30P 210mm (WK02100)	
490	WK673500	Push Button	AN-PA	6
			SELECT-CH1,SELECT-CH2, SELECT-CH3,SELECT-CH4, VOL-A,VOL-B	
500	--	Bind Head Screw	3x4 MFZN2B3 (WF10570)	5
505	--	Dust Guard	(WN41240)	
510	--	Flat Head Screw	4x8 MFZN2B3 (WE98030)	8
530	WK690800	Front Panel 2	AN-PA-LOW	
540	--	Adhesive Tape	#5000NS W=5mm (WG94020)	
545	--	Double Sided Adhesive Tape	15P LM (WM78140)	4
* 550	WK585400	LCD Cover	AN-PA	
* 560	WA587301	Level Meter	15P	4
* 570	WA773701	LED Lens	2P	7
* 580	WK585300	Lens Button	AN-PA	4
			MUTE-CH1,MUTE-CH2, MUTE-CH3,MUTE-CH4	
590	--	Bind Head Tapping Screw-S	3x6 MFZN2B3 (WF05470)	8
* 600	WN002600	Encoder Knob	AN-PA	
610	--	Plate	AN-PA (WK67780)	
620	--	Bind Head Tapping Screw-S	3x6 MFZN2B3 (WE87780)	2
630	--	Cord Binder	T18R TYTIN CO. (V327280)	9
640	--	Top Cover	AN-PA-LOW U (WK67010)	
640	--	Top Cover	AN-PA-LOW CHN (WK67020)	
650	--	Bind Head Screw	4x8 MFZN2B3 (WE96200)	13
660	--	Screw Cover	T5N (WJ61830)	8
670	--	Bind Head Tapping Screw-B	3x8 MFZN2B3 (WE77440)	8

*: New Parts

RANK: Japan only

OVERALL ASSEMBLY 2/2

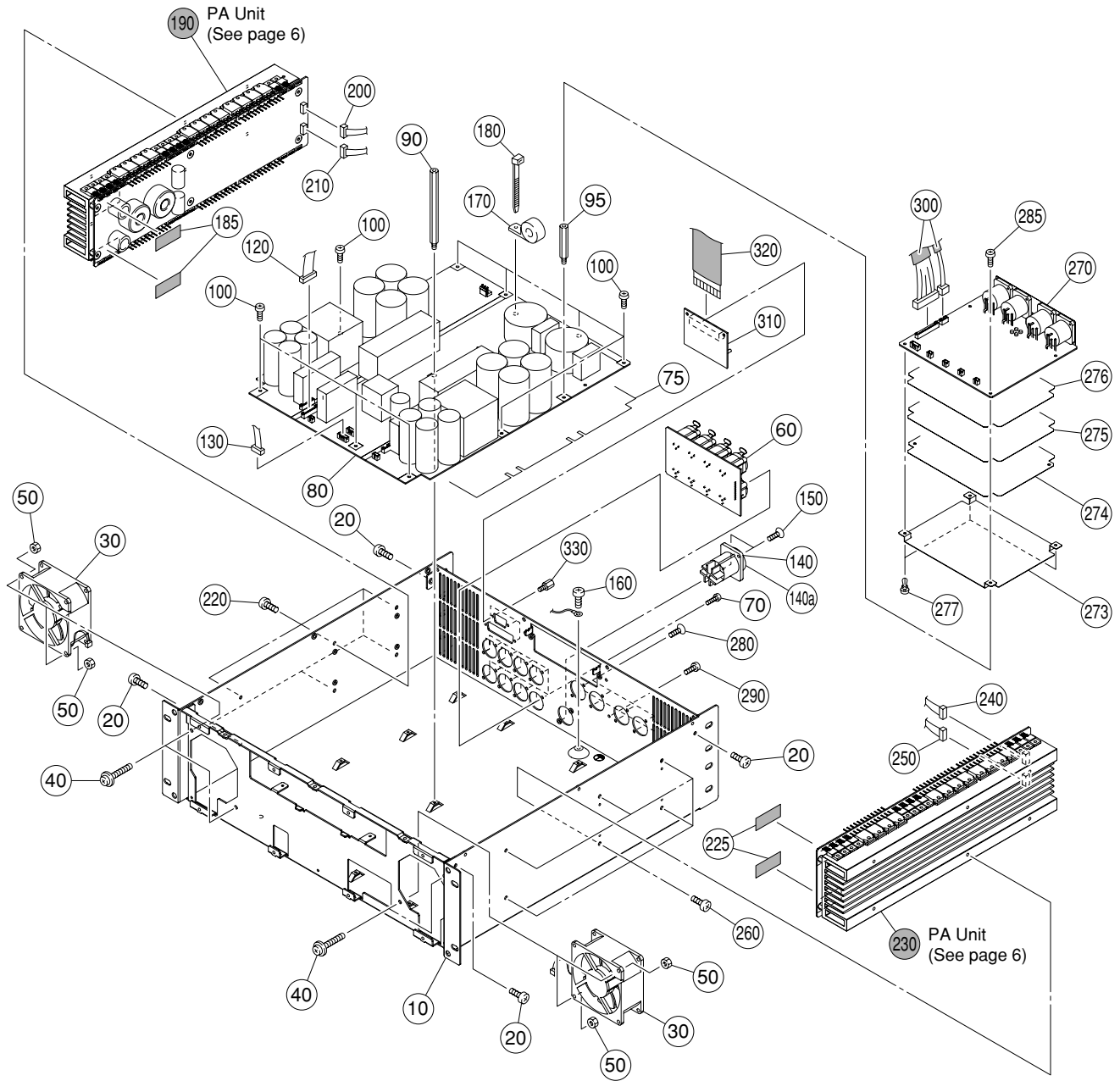

REF NO.	PART NO.	DESCRIPTION		REMARKS	QTY
* 10	WK668500	Main Chassis	AN-PA-LOW U	U	
* 10	WK668600	Main Chassis	AN-PA-LOW CHN	CHN	
20	--	Bind Head Screw	4x8 MFZN2B3		(WE96200) 4
30	V8746701	DC Fan	FBA08A24H1TZ		2
40	--	Bind Head Screw	4x35 MFZN2W3 SP		(WG16730) 4
50	--	Hexagonal Nut	M4 #1		(WG16920) 4
60	--	Circuit Board	INANL		(WJ97270)
70	--	Bind Head Tapping Screw-B	2.6x8 MFZN2B3		(WE96170) 16
75	--	Insulation Sheet PS	AN-PA		(WM98090)
80	WJ974100	Circuit Board	PSANL	U	
* 80	WJ974200	Circuit Board	PSANL	CHN	
90	--	Hexagonal Spacer	H=89 B=5.5		(WK67180)
95	--	Hexagonal Spacer	H=41 B=5.5		(WN00250)
100	--	Bind Head Tapping Screw-S	3x6 MFZN2W3		(WE87790)
120	--	Connector Assembly PH11P	C&C 11P 200mm		(WK68760)
130	--	Connector Assembly PH9P	C&C 9P 200mm		(WK68770)
140	--	Connector Assembly ACPS	20A POWERCON ASS'Y	U	(WK66050)
140a	--	AC Connector	NAC3MPA	U	(WK66030)
140	--	Connector Assembly ACPS	AC INLET ASS'Y	CHN	(WK66040)
140a	--	AC Inlet	AP-300-3-	CHN	(WF40880)
150	--	Flat Head Tapping Screw-B	3x8 MFZN2B3	U	(WF26680) 2
150	--	Bind Head Tapping Screw-B	3x8 MFZN2B3	CHN	(WE77440) 2
160	--	Bind Head Tapping Screw-S	4x8 MFZN2W3		(WE94180)
170	--	Ferrite Core	K1 NFT-13BK2		(V312290)
180	--	Cord Binder	T18R TYTIN CO.	U	(V327280) 2
180	--	Cord Binder	T18R TYTIN CO.	CHN	(V327280)
185	--	Adhesive Cloth Tape	15x30		(WG52680)
* 190	WJ949600	PA Unit	AN-PA-LOW 8F27		
200	--	Connector Assembly SIG-PA1	C&C 5P 420mm		(WK02080)
210	--	Wiring Assembly	C&C 5P 420mm		(WK90770)
220	--	Bind Head Screw	4x8 MFZN2B3		(WE96200) 6
225	--	Adhesive Cloth Tape	15x30		(WG52680)
* 230	WJ949600	PA Unit	AN-PA-LOW 8F27		
240	--	Wiring Assembly	C&C 5P 500mm		(WK90790)
250	--	Connector Assembly SIG-PA4	C&C 5P 500mm		(WK17110)
260	--	Bind Head Screw	4x8 MFZN2B3		(WE96200) 6
270	--	Circuit Board	OUTANL		(WJ97290)
273	--	Insulation Sheet 1	AN-PA		(WM14990)
274	--	Shield 1	AN-PA		(WM14970)
275	--	Shield 2	AN-PA		(WM14980)
276	--	Insulation Sheet 2	AN-PA		(WM15000)
277	--	Plastic Rivet	NRP-345		(CB81574) 3
280	--	Flat Head Tapping Screw-B	3x8 MFZN2B3		(WF26680) 8
285	--	Bind Head Tapping Screw-S	3x6 MFZN2W3		(WE87790)
290	--	Bind Head Tapping Screw-B	3x8 MFZN2B3		(WE77440)
300	--	Connector Assembly SENS	SENSE		(WK02090)
310	--	Circuit Board	RS232-GPI		(WJ97140)
320	--	FFC Assembly	WK02110,SUMITUBE		(WM15830)
330	--	Hexagonal Lock Screw			(WK51890) 4
		ACCESSORIES			
	WK602800	Power Cord Assembly	UL18A	U	
	WC901301	AC Cord	CHN 3 2.5m	CHN	

*: New Parts

RANK: Japan only

■ PA UNIT

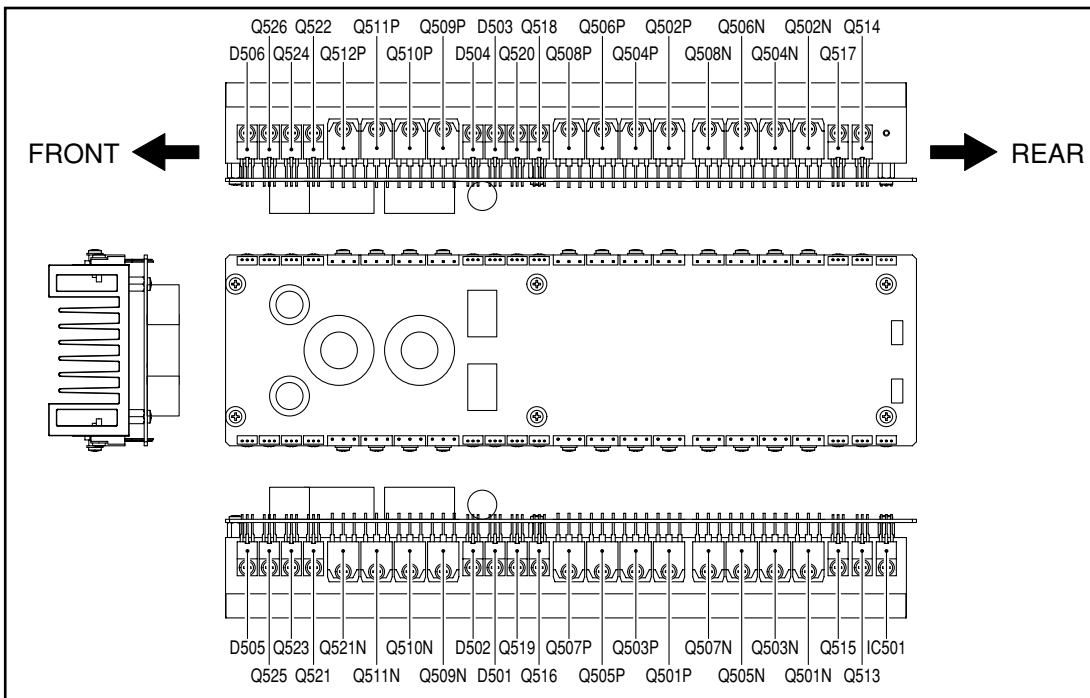
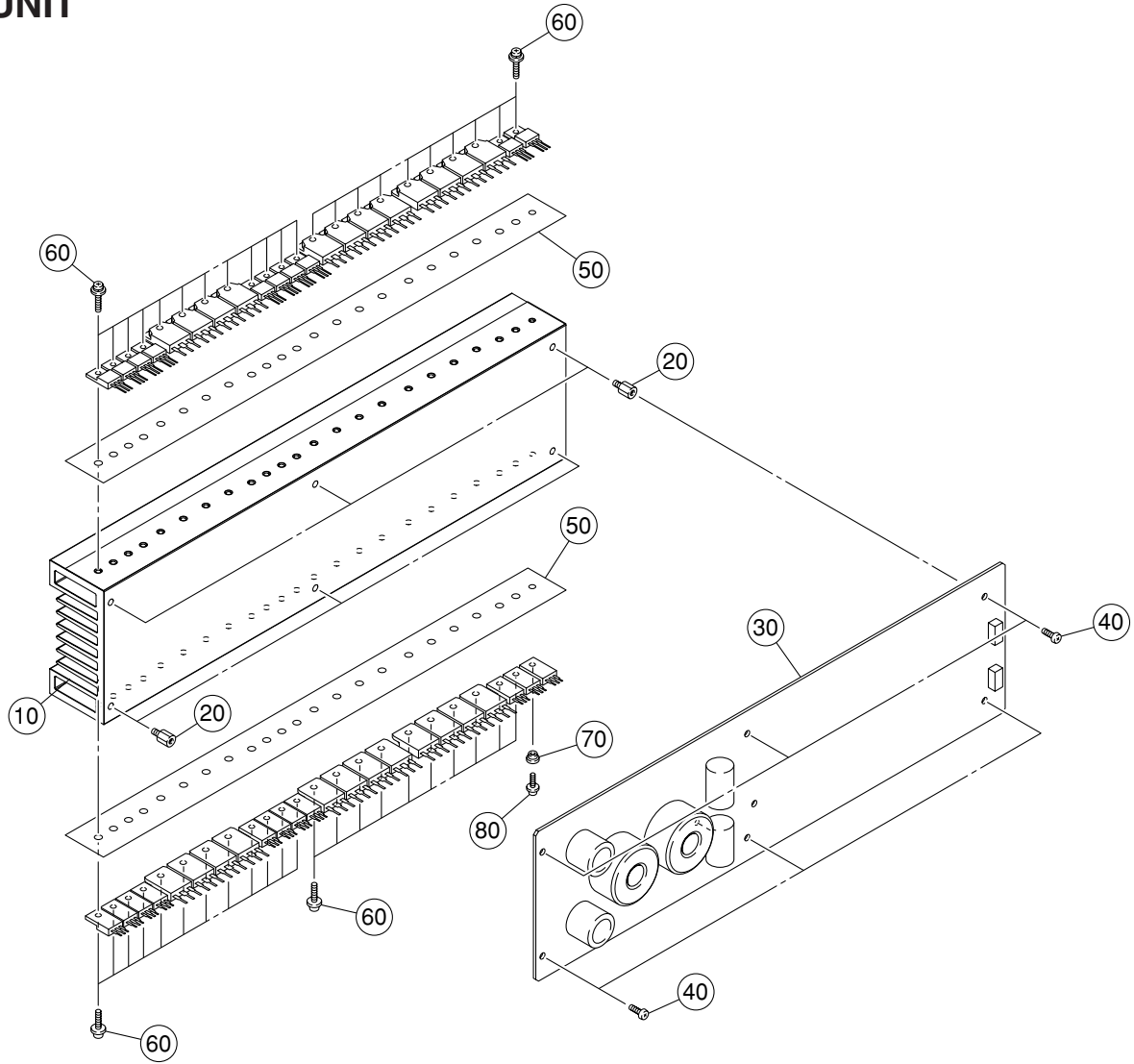

REF NO.	PART NO.	DESCRIPTION		REMARKS	QTY
10	WJ949600	PA Unit	AN-PA-LOW 8F27		
20	--	Heat Sink	AN-PA-LOW	(WJ94980)	
30	--	Hexagonal Spacer	H=7.5 B=5.5	(WD49000)	6
40	--	Circuit Board	PAANL	(WJ97250)	
50	--	Bind Head Tapping Screw-S	3x6 MFZN2W3	(WE87790)	6
60	--	Insulation Sheet	PA-L TBM51W T=0.15	(WK11930)	2
70	--	Bind Head Screw	3x12 MFZN2W3 SP	(WE87770)	44
80	--	Insulation Bushing	2.6M	(WA00920)	
D501	--	Bind Head Screw	2.6x8 MFZN2W3 SP	(WE96770)	
D502	--	Diode	SF20L60U	(V635170)	
D503	--	Diode	SF20L60U	(V635170)	
D504	--	Diode	SF20L60U	(V635170)	
D505	--	Diode	SF20L60U	(V635170)	
D506	--	Diode	SF20L60U	(V635170)	
IC501	--	IC	LM35DT	THERMO SENSOR (X0670A0)	
Q513	WJ461500	Transistor	2SA1668A LFNO.600		
Q514	WJ461500	Transistor	2SA1668A LFNO.600		
Q515	WJ461600	Transistor	2SC4382A LFNO.600		
Q516	WJ461500	Transistor	2SA1668A LFNO.600		
Q517	WJ461600	Transistor	2SC4382A LFNO.600		
Q518	WJ461500	Transistor	2SA1668A LFNO.600		
Q519	WJ461600	Transistor	2SC4382A LFNO.600		
Q520	WJ461500	Transistor	2SA1668A LFNO.600		
Q521	V8093501	FET	2SK3003		
Q522	V8093501	FET	2SK3003		
Q523	V8093501	FET	2SK3003		
Q524	V8093501	FET	2SK3003		
Q525	V8093501	FET	2SK3003		
Q526	V8093501	FET	2SK3003		
Q501N	V8094901	Pair Transistor	A1492A/C3856A		
Q501P	V8094901	Pair Transistor	A1492A/C3856A		
Q502N	V8094901	Pair Transistor	A1492A/C3856A		
Q502P	V8094901	Pair Transistor	A1492A/C3856A		
Q503N	V8094901	Pair Transistor	A1492A/C3856A		
Q503P	V8094901	Pair Transistor	A1492A/C3856A		
Q504N	V8094901	Pair Transistor	A1492A/C3856A		
Q504P	V8094901	Pair Transistor	A1492A/C3856A		
Q505N	V8094901	Pair Transistor	A1492A/C3856A		
Q505P	V8094901	Pair Transistor	A1492A/C3856A		
Q506N	V8094901	Pair Transistor	A1492A/C3856A		
Q506P	V8094901	Pair Transistor	A1492A/C3856A		
Q507N	V8094901	Pair Transistor	A1492A/C3856A		
Q507P	V8094901	Pair Transistor	A1492A/C3856A		
Q508N	V8094901	Pair Transistor	A1492A/C3856A		
Q508P	V8094901	Pair Transistor	A1492A/C3856A		
Q509N	V8094901	Pair Transistor	A1492A/C3856A		
Q509P	V8094901	Pair Transistor	A1492A/C3856A		
Q510N	V8094901	Pair Transistor	A1492A/C3856A		
Q510P	V8094901	Pair Transistor	A1492A/C3856A		
Q511N	V8094901	Pair Transistor	A1492A/C3856A		
Q511P	V8094901	Pair Transistor	A1492A/C3856A		
Q512N	V8094901	Pair Transistor	A1492A/C3856A		
Q512P	V8094901	Pair Transistor	A1492A/C3856A		

*: New Parts

RANK: Japan only

■ LCD ASSEMBLY

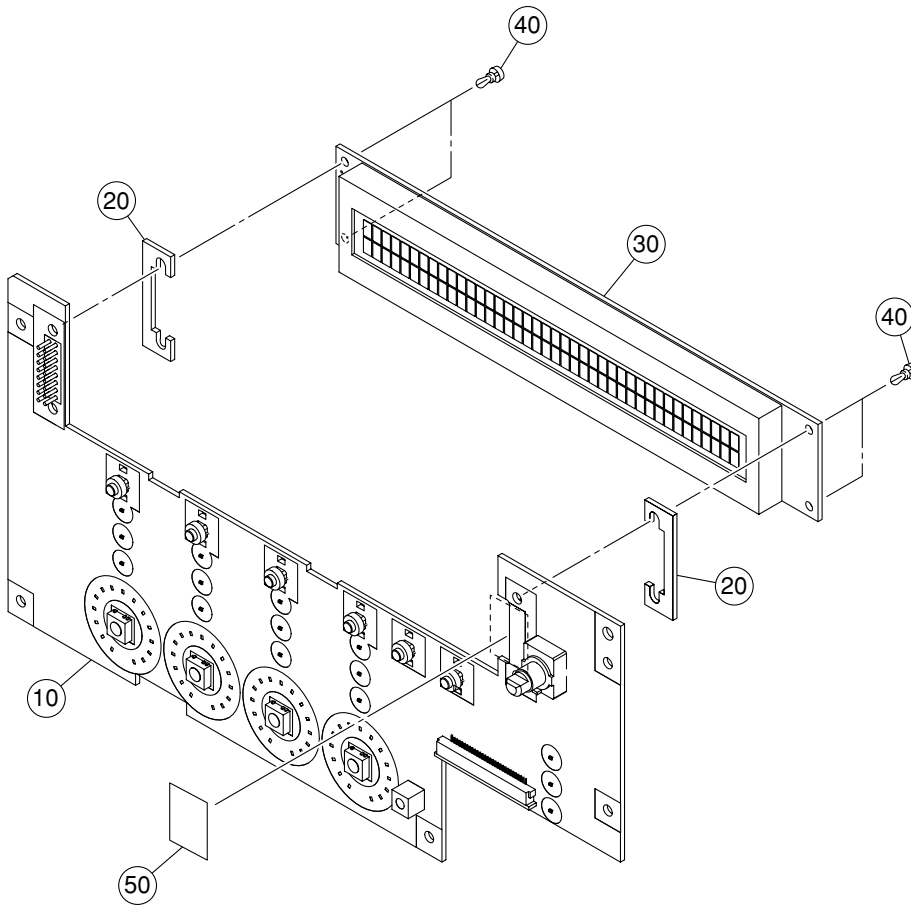

REF NO.	PART NO.	DESCRIPTION		REMARKS	QTY
	--	LCD Assembly	PA 8F27_8F28	(WK75670)	
10	--	Circuit Board	PN-AN	(WJ97130)	
20	--	Circuit Board	LCD SPACER	(WK62420)	2
30	--	LCD Module	CMS-CC2N0124UBSW-W	(WJ43880)	
40	--	Nylon Rivet	P3570-W/BW	(WK67760)	4
50	--	Acetate Tape	#570F W=19	(WG52600)	

*: New Parts

RANK: Japan only

■ LOCATIONS OF HEAT SINK UNITS

Details on PSANL Circuit Board

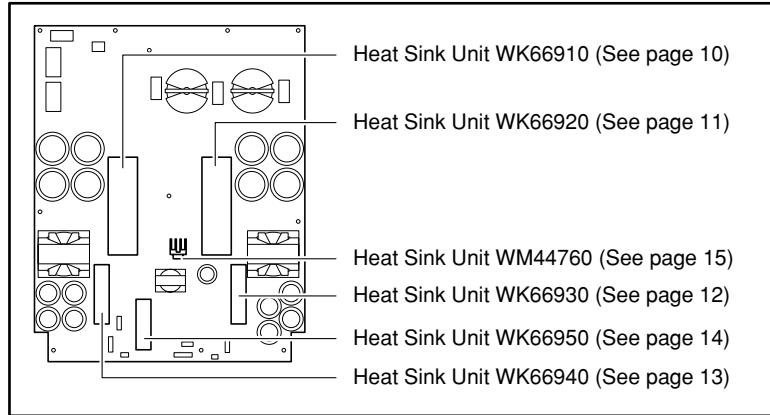

HEAT SINK UNIT L100

PSANL Circuit Board

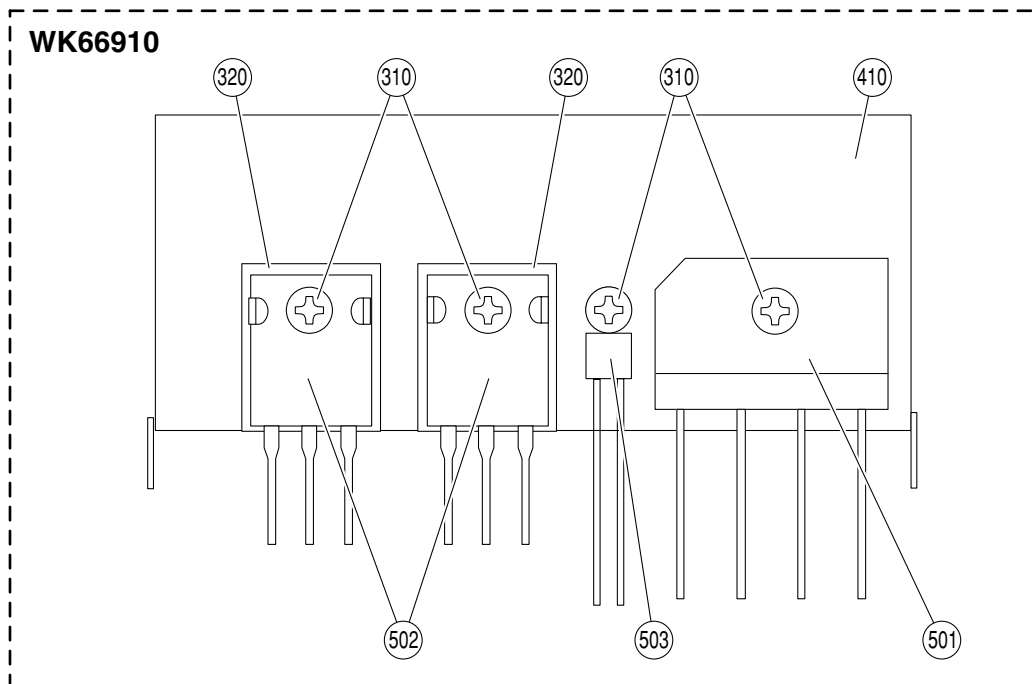
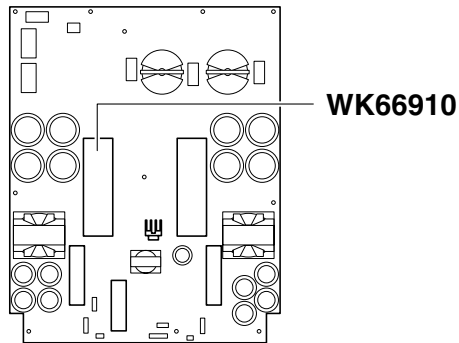

REF NO.	PART NO.	DESCRIPTION		REMARKS	QTY
310	--	Heat Sink Unit	AN-PA-HIGH 100mm	(WK66910)	4
	--	Bind Head Screw	3x10 MFZN2W3	(WE95290)	2
320	--	Radiation Sheet	RSI T=0.07	(WB44860)	2
410	--	Heat Sink PS	L100 ASSY	(WM69000)	
501	--	Diode Stack	RBV-3006 30A 600V	(WH26830)	
502	WH268401	Transistor	IRG4PC60UPBF		2
503	--	Thermistor	PTMS2331RP716 P7(8)	(WH32400)	

*: New Parts

RANK: Japan only

HEAT SINK UNIT L100

PSANL Circuit Board

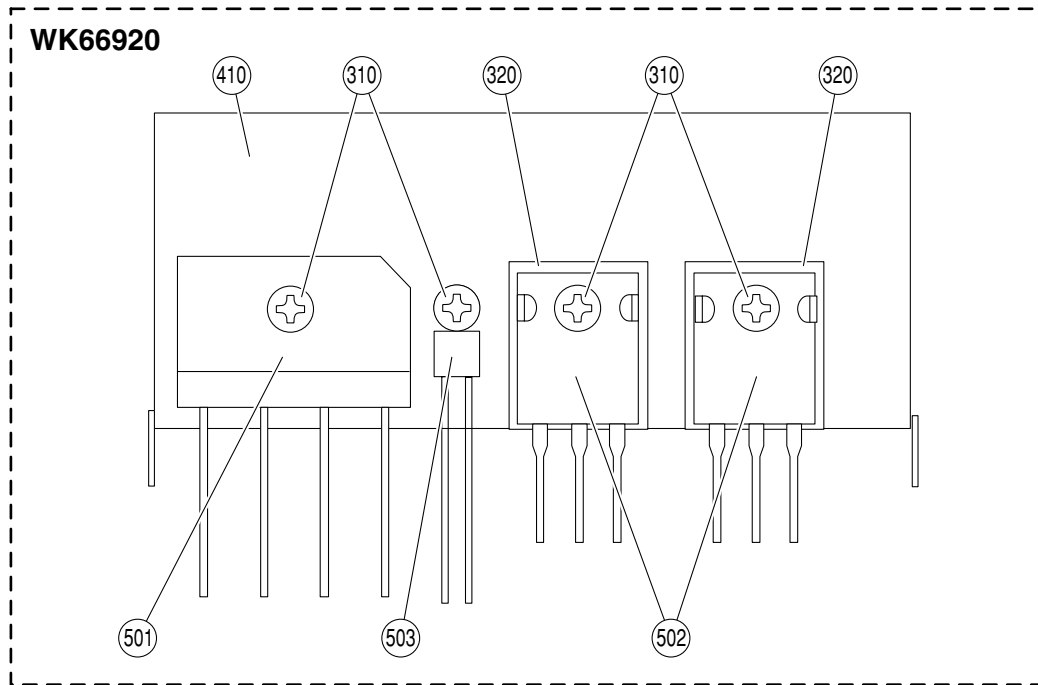
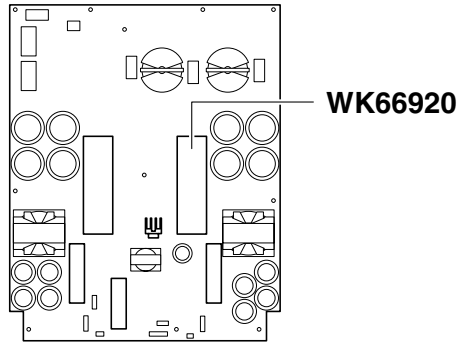

REF. NO.	PART NO.	DESCRIPTION		REMARKS	QTY
310	--	Heat Sink Unit	AN-PA-HIGH 100mm	(WK66920)	4
	--	Bind Head Screw	3x10 MFZN2W3	(WE95290)	2
320	--	Radiation Sheet	RSI T=0.07	(WB44860)	2
410	--	Heat Sink PS	L100 ASSY	(WM69000)	
501	--	Diode Stack	RBV-3006 30A 600V	(WH26830)	
502	WH268401	Transistor	IRG4PC60UPBF		2
503	--	Thermistor	PTMS2331RP716 P7(8)	(WH32400)	

*: New Parts

RANK: Japan only

HEAT SINK UNIT L60

PSANL Circuit Board

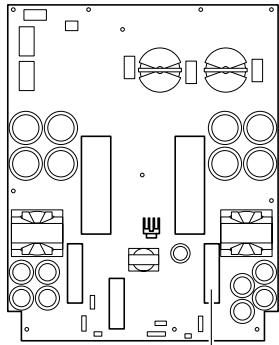

WK66930

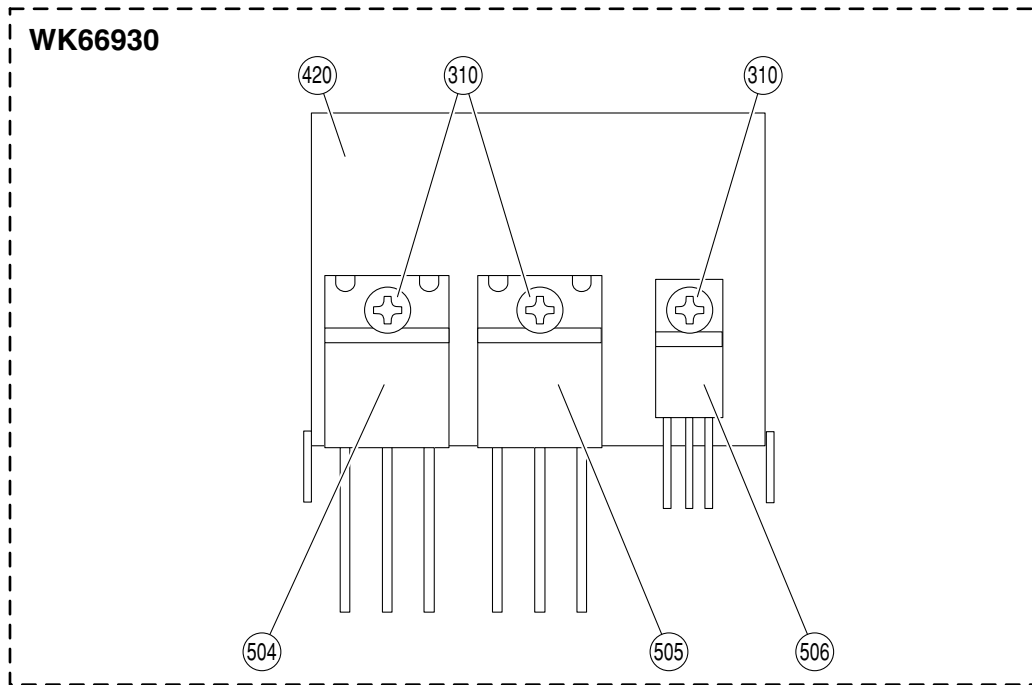

REF NO.	PART NO.	DESCRIPTION		REMARKS	QTY
310	--	Heat Sink Unit	AN-PA-HIGH 60mm	(WK66930)	3
	--	Bind Head Screw	3x10 MFZN2W3	(WE95290)	
420	--	Heat Sink PS	L60 ASSY	(WM69020)	
504	--	Diode Stack	FMU-36R 20A 600V	(V849870)	
505	--	Diode Stack	FMU-36S 20A 600V	(VN39950)	
506	--	Transistor	2SD2394 E,F ST	(VS88340)	

*: New Parts

RANK: Japan only

HEAT SINK UNIT L60

PSANL Circuit Board

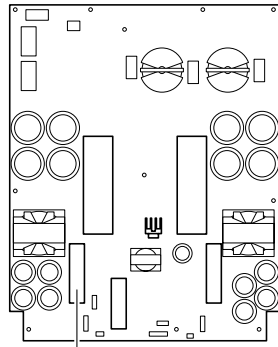

WK66940

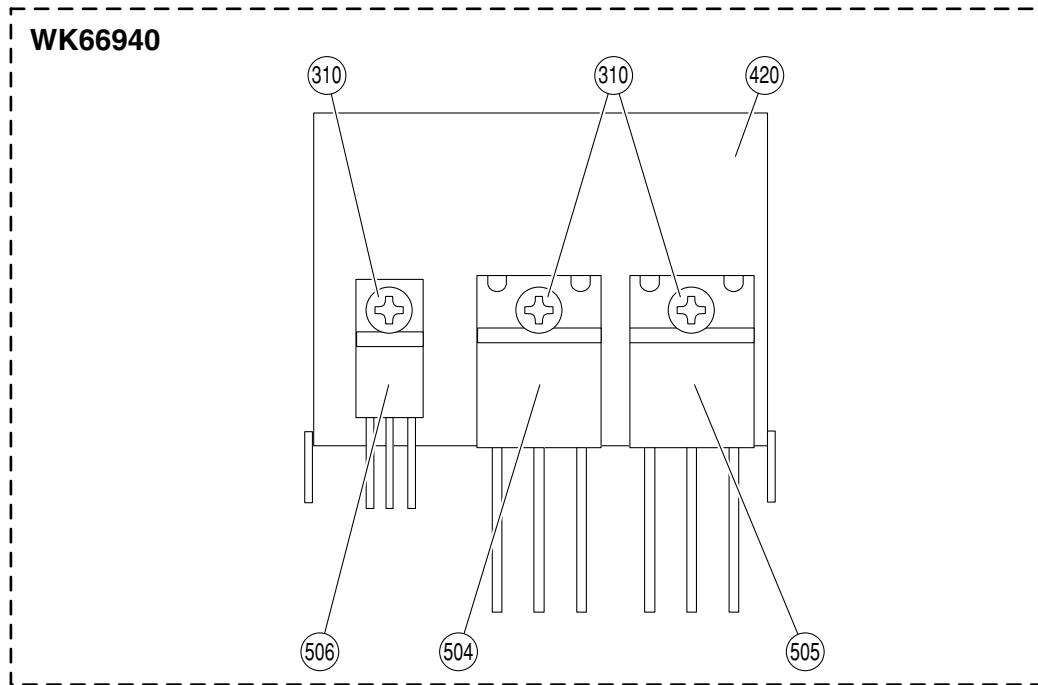

REF. NO.	PART NO.	DESCRIPTION		REMARKS	QTY
310	--	Heat Sink Unit	AN-PA-HIGH 60mm	(WK66940)	
420	--	Bind Head Screw	3x10 MFZN2W3	(WE95290)	3
504	--	Diode Stack	FMU-36R 20A 600V	(V849870)	
505	--	Diode Stack	FMU-36S 20A 600V	(VN39950)	
506	--	Transistor	2SD2394 E,F ST	(VS88340)	

*: New Parts

RANK: Japan only

HEAT SINK UNIT L50

PSANL Circuit Board

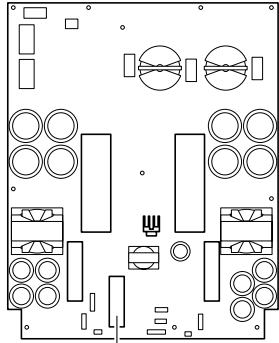

WK66950

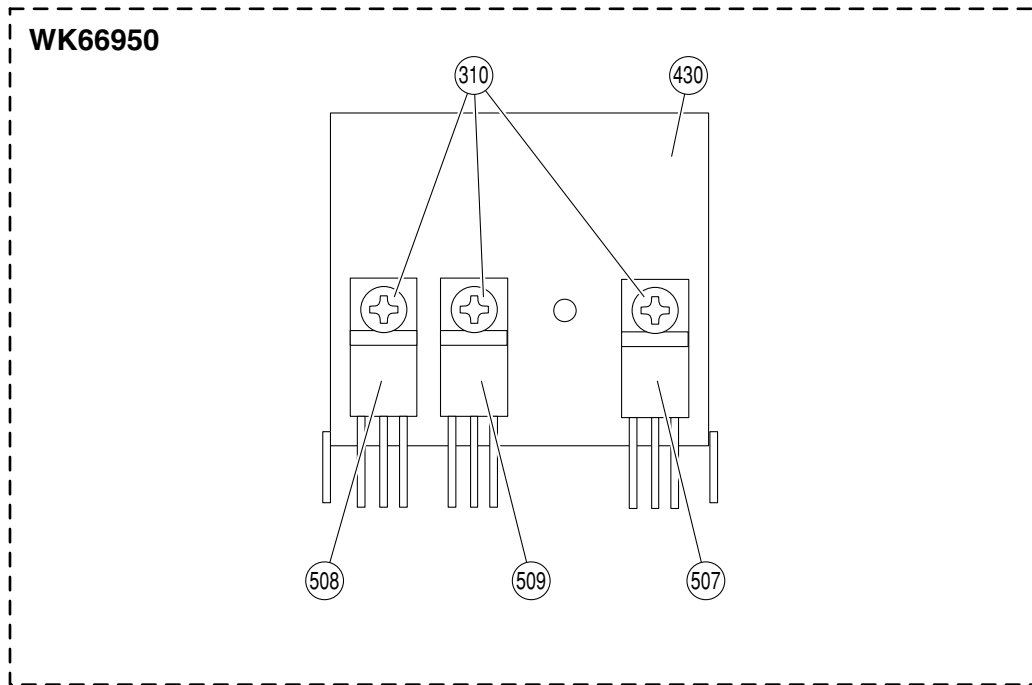

REF NO.	PART NO.	DESCRIPTION		REMARKS	QTY
310	--	Heat Sink Unit	AN-PA-HIGH 50mm	(WK66950)	3
	--	Bind Head Screw	3x10 MFZN2W3	(WE95290)	
430	--	Heat Sink PS	L50 ASSY	(WM69030)	
507	--	Schottky Diode	10A 60V SF10SC6	(WF41740)	
508	--	IC	NJM7815FA	REGULATOR +15V (XD853A0)	
509	--	IC	NJM7915FA	REGULATOR -15V (XD854A0)	

*: New Parts

RANK: Japan only

HEAT SINK UNIT OSH

PSANL Circuit Board

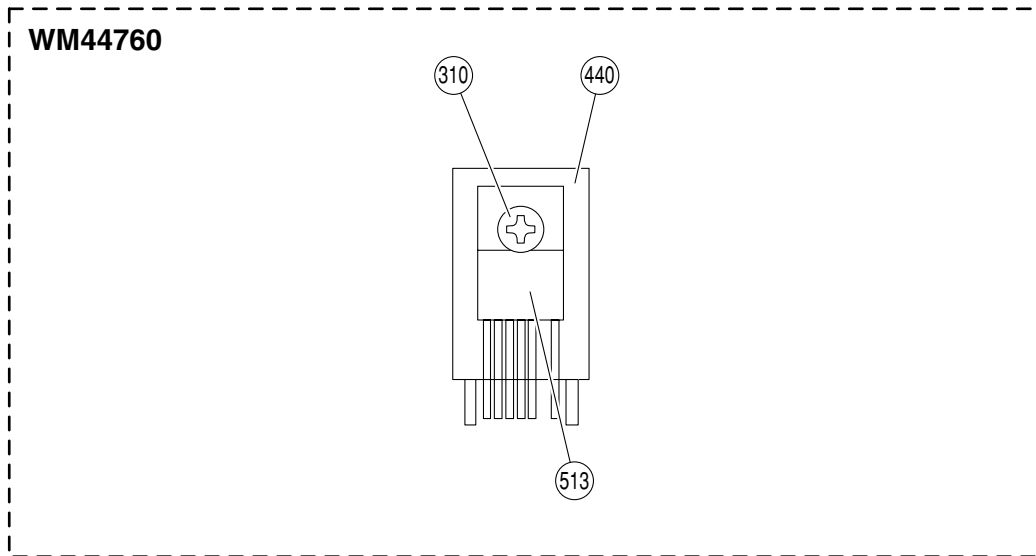
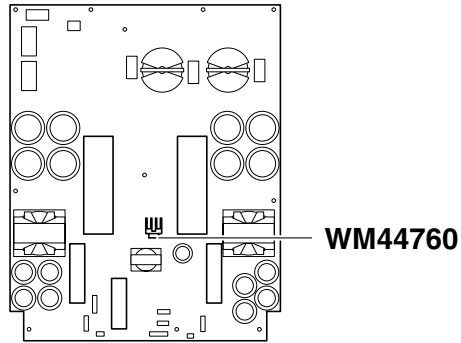

REF NO.	PART NO.	DESCRIPTION		REMARKS	QTY
310	--	Heat Sink Unit	NX,TX6 25mm	(WM44760)	
440	--	Bind Head Screw	3x10 MFZN2W3	(WE95290)	
513	--	Heat Sink	OSH-1625-SFL	(WM45790)	
		IC	TOP246YN IPD	REGULATOR (X8576A0)	

*: New Parts

RANK: Japan only

■ ELECTRICAL PARTS (電気部品)

REF NO.	PART NO.	DESCRIPTION	REMARKS	QTY
		ELECTRICAL PARTS		
*	WK044100	Circuit Board	CONTROL (X8710C0)	
*	WJ972700	Circuit Board	INANL (WJ97330)(X8714C0)	
*	WJ972900	Circuit Board	OUTANL (WJ97330)(X8714C0)	
*	WJ971500	Circuit Board	OPT-AN (WJ97170)(X8711C0)	
*	WJ971300	Circuit Board	PN-AN (WJ97170)(X8711C0)	
*	WJ971400	Circuit Board	RS232-GPI (WJ97170)(X8711C0)	
*	WK624200	Circuit Board	LCD SPACER (WJ97170)(X8711C0)	
*	WJ972500	Circuit Board	PAANL (WJ97310)(X8713D0)	
*	WJ974100	Circuit Board	PSANL U (X8715D0)	
*	WJ974200	Circuit Board	PSANL CHN (X8715D0)	
*	WK044100	Circuit Board	CONTROL (X8710C0)	
C001	--	Mylar Capacitor (chip)	2200pF 50V J (WB57540)	
-004	--	Mylar Capacitor (chip)	2200pF 50V J (WB57540)	
C005	--	Ceramic Capacitor-F (chip)	0.1uF 50V Z (US06510)	
C006	--	Electrolytic Cap. (chip)	10uF 50V (UF06710)	
C007	--	Ceramic Capacitor-F (chip)	0.1uF 50V Z (US06510)	
C008	--	Electrolytic Cap. (chip)	10uF 50V (UF06710)	
C009	--	Ceramic Capacitor-F (chip)	0.1uF 50V Z (US06510)	
C010	--	Ceramic Capacitor-F (chip)	0.1uF 50V Z (US06510)	
C011	--	Electrolytic Cap. (chip)	10uF 50V (UF06710)	
C012	--	Ceramic Capacitor-F (chip)	0.1uF 50V Z (US06510)	
C013	--	Ceramic Capacitor-F (chip)	0.1uF 50V Z (US06510)	
C014	--	Ceramic Capacitor-CH(chip)	56pF 50V J (US06156)	
-017	--	Ceramic Capacitor-CH(chip)	56pF 50V J (US06156)	
C018	--	Ceramic Capacitor-F (chip)	0.1uF 50V Z (US06510)	
C019	--	Electrolytic Cap.	22uF 25V (WC89280)	
-022	--	Electrolytic Cap.	22uF 25V (WC89280)	
C027	--	Ceramic Capacitor-F (chip)	0.1uF 50V Z (US06510)	
-031	--	Ceramic Capacitor-F (chip)	0.1uF 50V Z (US06510)	
C032	--	Electrolytic Cap. (chip)	100uF 16V (UF03810)	
C033	--	Electrolytic Cap. (chip)	100uF 16V (UF03810)	
C034	--	Ceramic Capacitor-F (chip)	0.1uF 50V Z (US06510)	
C035	--	Ceramic Capacitor-F (chip)	0.1uF 50V Z (US06510)	
C036	--	Electrolytic Cap. (chip)	1.0uF 50V (UF06610)	
C037	--	Electrolytic Cap. (chip)	1.0uF 50V (UF06610)	
C038	--	Electrolytic Cap. (chip)	10uF 50V (UF06710)	
-045	--	Electrolytic Cap. (chip)	10uF 50V (UF06710)	
C046	--	Ceramic Capacitor-B (chip)	0.01uF 50V K (US06410)	
-049	--	Ceramic Capacitor-B (chip)	0.01uF 50V K (US06410)	
C050	--	Ceramic Capacitor-F (chip)	0.1uF 50V Z (US06510)	
-053	--	Ceramic Capacitor-F (chip)	0.1uF 50V Z (US06510)	
C054	--	Ceramic Capacitor-SL(chip)	470pF 50V J (US06247)	
-061	--	Ceramic Capacitor-SL(chip)	470pF 50V J (US06247)	
C062	--	Ceramic Capacitor-F (chip)	0.1uF 50V Z (US06510)	
C063	--	Ceramic Capacitor-F (chip)	0.1uF 50V Z (US06510)	
C064	--	Mylar Capacitor (chip)	2700pF 50V J (WB57550)	
C065	--	Mylar Capacitor (chip)	2700pF 50V J (WB57550)	
C066	--	Ceramic Capacitor-F (chip)	0.1uF 50V Z (US06510)	
C067	--	Mylar Capacitor (chip)	2700pF 50V J (WB57550)	
C068	--	Mylar Capacitor (chip)	2700pF 50V J (WB57550)	
C069	--	Ceramic Capacitor-F (chip)	0.1uF 50V Z (US06510)	
C070	--	Ceramic Capacitor-F (chip)	1.0uF 10V Z (US12610)	
C071	--	Ceramic Capacitor-F (chip)	1.0uF 10V Z (US12610)	
C072	--	Ceramic Capacitor-F (chip)	0.1uF 50V Z (US06510)	
-075	--	Ceramic Capacitor-F (chip)	0.1uF 50V Z (US06510)	
C076	--	Ceramic Capacitor-F (chip)	1.0uF 10V Z (US12610)	
C077	--	Ceramic Capacitor-F (chip)	1.0uF 10V Z (US12610)	
C079	--	Ceramic Capacitor-F (chip)	1.0uF 10V Z (US12610)	
C080	--	Ceramic Capacitor-F (chip)	1.0uF 10V Z (US12610)	
C081	--	Ceramic Capacitor-F (chip)	0.1uF 50V Z (US06510)	
-084	--	Ceramic Capacitor-F (chip)	0.1uF 50V Z (US06510)	
C085	--	Electrolytic Cap. (chip)	47uF 16V (UF03747)	
C086	--	Electrolytic Cap. (chip)	47uF 16V (UF03747)	
C115	--	Ceramic Capacitor-SL(chip)	560pF 50V J (US06256)	
-118	--	Ceramic Capacitor-SL(chip)	560pF 50V J (US06256)	
C121	--	Ceramic Capacitor-SL(chip)	560pF 50V J (US06256)	
-124	--	Ceramic Capacitor-SL(chip)	560pF 50V J (US06256)	
C131	--	Ceramic Capacitor-F (chip)	0.1uF 50V Z (US06510)	

*: New Parts

RANK: Japan only

CONTROL

REF NO.	PART NO.	DESCRIPTION		REMARKS	QTY
-136	--	Ceramic Capacitor-F (chip)	0.1uF 50V Z	(US06510)	
C137	--	Mylar Capacitor (chip)	2200pF 50V J	(WB57540)	
-140	--	Mylar Capacitor (chip)	2200pF 50V J	(WB57540)	
C141	--	Ceramic Capacitor-F (chip)	0.1uF 50V Z	(US06510)	
-150	--	Ceramic Capacitor-F (chip)	0.1uF 50V Z	(US06510)	
C151	--	Ceramic Capacitor-B (chip)	1000pF 50V K	(US06310)	
C152	--	Ceramic Capacitor-B (chip)	1000pF 50V K	(US06310)	
C153	--	Ceramic Capacitor-F (chip)	0.1uF 50V Z	(US06510)	
-160	--	Ceramic Capacitor-F (chip)	0.1uF 50V Z	(US06510)	
C161	--	Electrolytic Cap. (chip)	10uF 50V	(UF06710)	
C162	--	Ceramic Capacitor-F (chip)	0.1uF 50V Z	(US06510)	
C163	--	Ceramic Capacitor-F (chip)	0.1uF 50V Z	(US06510)	
C164	--	Electrolytic Cap. (chip)	10uF 50V	(UF06710)	
C165	--	Electrolytic Cap. (chip)	10uF 50V	(UF06710)	
C189	--	Ceramic Capacitor-CH(chip)	56pF 50V J	(US06156)	
-192	--	Ceramic Capacitor-CH(chip)	56pF 50V J	(US06156)	
C193	--	Ceramic Capacitor-B (chip)	0.01uF 50V K	(US06410)	
C194	--	Ceramic Capacitor-B (chip)	0.01uF 50V K	(US06410)	
C195	--	Ceramic Capacitor-CH(chip)	56pF 50V J	(US06156)	
-198	--	Ceramic Capacitor-CH(chip)	56pF 50V J	(US06156)	
C199	--	Ceramic Capacitor-B (chip)	0.01uF 50V K	(US06410)	
C200	--	Electrolytic Cap. (chip)	10uF 50V	(UF06710)	
-203	--	Electrolytic Cap. (chip)	10uF 50V	(UF06710)	
C204	--	Ceramic Capacitor-B (chip)	0.01uF 50V K	(US06410)	
C205	--	Mylar Capacitor (chip)	0.01uF 50V J	(WB57620)	
-212	--	Mylar Capacitor (chip)	0.01uF 50V J	(WB57620)	
C213	--	Ceramic Capacitor-B (chip)	0.01uF 50V K	(US06410)	
-215	--	Ceramic Capacitor-B (chip)	0.01uF 50V K	(US06410)	
C216	--	Ceramic Capacitor-F (chip)	0.1uF 50V Z	(US06510)	
-219	--	Ceramic Capacitor-F (chip)	0.1uF 50V Z	(US06510)	
C220	--	Ceramic Capacitor-B (chip)	0.01uF 50V K	(US06410)	
C221	--	Electrolytic Cap. (chip)	10uF 50V	(UF06710)	
-224	--	Electrolytic Cap. (chip)	10uF 50V	(UF06710)	
C225	--	Ceramic Capacitor-B (chip)	0.01uF 50V K	(US06410)	
C226	--	Ceramic Capacitor-F (chip)	0.1uF 50V Z	(US06510)	
-233	--	Ceramic Capacitor-F (chip)	0.1uF 50V Z	(US06510)	
C234	--	Ceramic Capacitor-B (chip)	0.01uF 50V K	(US06410)	
C235	--	Electrolytic Cap. (chip)	10uF 50V	(UF06710)	
-242	--	Electrolytic Cap. (chip)	10uF 50V	(UF06710)	
C243	--	Ceramic Capacitor-B (chip)	0.01uF 50V K	(US06410)	
-245	--	Ceramic Capacitor-B (chip)	0.01uF 50V K	(US06410)	
C246	--	Ceramic Capacitor-F (chip)	0.1uF 50V Z	(US06510)	
-249	--	Ceramic Capacitor-F (chip)	0.1uF 50V Z	(US06510)	
C250	--	Ceramic Capacitor-B (chip)	0.01uF 50V K	(US06410)	
C251	--	Electrolytic Cap. (chip)	10uF 50V	(UF06710)	
-254	--	Electrolytic Cap. (chip)	10uF 50V	(UF06710)	
C255	--	Ceramic Capacitor-CH(chip)	12pF 50V J	(US06112)	
C256	--	Ceramic Capacitor-F (chip)	0.1uF 50V Z	(US06510)	
C257	--	Ceramic Capacitor-CH(chip)	12pF 50V J	(US06112)	
C258	--	Ceramic Capacitor-F (chip)	0.1uF 50V Z	(US06510)	
-263	--	Ceramic Capacitor-F (chip)	0.1uF 50V Z	(US06510)	
C264	--	Electrolytic Cap. (chip)	22uF 6.3V	(UF01722)	
C265	--	Ceramic Capacitor-F (chip)	0.1uF 50V Z	(US06510)	
C266	--	Ceramic Capacitor-B (chip)	1500pF 50V K	(US06315)	
C267	--	Ceramic Capacitor-B (chip)	1500pF 50V K	(US06315)	
C268	--	Ceramic Capacitor-F (chip)	0.1uF 50V Z	(US06510)	
-270	--	Ceramic Capacitor-F (chip)	0.1uF 50V Z	(US06510)	
C273	--	Ceramic Capacitor-F (chip)	0.1uF 50V Z	(US06510)	
C277	--	Monolithic Ceramic Cap.	10uF 6.3V K	(WG96940)	
-280	--	Monolithic Ceramic Cap.	10uF 6.3V K	(WG96940)	
C281	--	Ceramic Capacitor-F (chip)	0.1uF 50V Z	(US06510)	
-284	--	Ceramic Capacitor-F (chip)	0.1uF 50V Z	(US06510)	
C285	--	Ceramic Capacitor-B (chip)	0.04uF 16V K	(US03447)	
C286	--	Ceramic Capacitor-F (chip)	0.1uF 50V Z	(US06510)	
C289	--	Ceramic Capacitor-F (chip)	0.1uF 50V Z	(US06510)	
C291	--	Ceramic Capacitor-F (chip)	0.1uF 50V Z	(US06510)	
C294	--	Ceramic Capacitor-F (chip)	0.1uF 50V Z	(US06510)	
C296	--	Ceramic Capacitor-F (chip)	0.1uF 50V Z	(US06510)	
-306	--	Ceramic Capacitor-F (chip)	0.1uF 50V Z	(US06510)	
C307	--	Electrolytic Cap. (chip)	100uF 16V	(UF03810)	

*: New Parts

RANK: Japan only

CONTROL

REF NO.	PART NO.	DESCRIPTION		REMARKS	QTY
C308	--	Electrolytic Cap. (chip)	100uF 16V	(UF03810)	
C309	--	Ceramic Capacitor-F (chip)	0.1uF 50V Z	(US06510)	
C311	--	Ceramic Capacitor-B(chip)	0.1uF 50V K	(WD96920)	
-321	--	Ceramic Capacitor-B(chip)	0.1uF 50V K	(WD96920)	
C330	--	Ceramic Capacitor-B(chip)	0.1uF 50V K	(WD96920)	
-336	--	Ceramic Capacitor-B(chip)	0.1uF 50V K	(WD96920)	
C337	--	Ceramic Capacitor-B (chip)	0.01uF 50V K	(US06410)	
C338	--	Ceramic Capacitor-F (chip)	0.1uF 50V Z	(US06510)	
C339	--	Ceramic Capacitor-F (chip)	1.0uF 10V Z	(US12610)	
C341	--	Mylar Capacitor (chip)	2200pF 50V J	(WB57540)	
-344	--	Mylar Capacitor (chip)	2200pF 50V J	(WB57540)	
C345	--	Ceramic Capacitor-B(chip)	820pF 50V K	(US06282)	
-348	--	Ceramic Capacitor-B(chip)	820pF 50V K	(US06282)	
C349	--	Ceramic Capacitor-SL(chip)	120pF 50V J	(US06212)	
-352	--	Ceramic Capacitor-SL(chip)	120pF 50V J	(US06212)	
C353	--	Electrolytic Cap.	22uF 25V	(WC89280)	
-356	--	Electrolytic Cap.	22uF 25V	(WC89280)	
C357	--	Ceramic Capacitor-F (chip)	0.1uF 50V Z	(US06510)	
C358	--	Electrolytic Cap. (chip)	100uF 16V	(UF03810)	
C359	--	Ceramic Capacitor-F (chip)	1.0uF 10V Z	(US12610)	
-362	--	Ceramic Capacitor-F (chip)	1.0uF 10V Z	(US12610)	
C363	--	Electrolytic Cap. (chip)	10uF 50V	(UF06710)	
C364	--	Electrolytic Cap. (chip)	10uF 50V	(UF06710)	
C821	--	Ceramic Capacitor-F (chip)	0.1uF 50V Z	(US06510)	
-831	--	Ceramic Capacitor-F (chip)	0.1uF 50V Z	(US06510)	
CN005	--	P.C.B Connector	HTSS 14P TE	(WN05930)	
CN006	--	Base Post	PH 13P	(VT38940)	
CN007	--	Connector Base Post	PH 11P TE	(VT38920)	
CN009	--	Connector, FFC/FPC	52808 30P TP	(V441510)	
CN010	--	Connector, FFC/FPC	52808 30P TP	(V441510)	
CN011	--	Base Post Connector	PH 9P TE	(VT38900)	
CN012	--	Base Post Connector	PH 5P TE	(VT38860)	
-015	--	Base Post Connector	PH 5P TE	(VT38860)	
CN016	--	Base Post	PH 12P	(VT38930)	
CN017	--	Connector	FMN 40P	(WC19900)	
D001	--	Diode (chip)	RB160L-40 TE25	(VS59760)	
-004	--	Diode (chip)	RB160L-40 TE25	(VS59760)	
D005	--	Diode	SMP100LC-25	(WJ52830)	
D006	--	Diode	SMP100LC-25	(WJ52830)	
DA001	--	Diode Array	0.3Ax2 DAN217	(VV55630)	
-036	--	Diode Array	0.3Ax2 DAN217	(VV55630)	
EM001	--	Coil (chip)	31PT222Z1E9L TP	(VZ58110)	
-003	--	Coil (chip)	31PT222Z1E9L TP	(VZ58110)	
IC001	--	IC	CS3318-CQZ	VOLUME CONTROLLER (X8486A0)	
IC002	--	IC	NJM2068M-D(TE2)	OP AMP (X3505A0)	
-005	--	IC	NJM2068M-D(TE2)	OP AMP (X3505A0)	
IC006	--	IC	NJM78M09DL1A(TE1)	REGULATOR (XZ940A0)	
IC007	--	IC	NJM79M09DL1A -9V	REGULATOR (X5366A0)	
IC008	--	IC	NJM2068M-D(TE2)	OP AMP (X3505A0)	
-011	--	IC	NJM2068M-D(TE2)	OP AMP (X3505A0)	
IC012	--	IC	CS4272-CZZR	CODEC (X8487A0)	
IC013	--	IC	CS4272-CZZR	CODEC (X8487A0)	
IC018	--	IC	NJM2068M-D(TE2)	OP AMP (X3505A0)	
-021	--	IC	NJM2068M-D(TE2)	OP AMP (X3505A0)	
IC022	--	IC	DSPB56371AF180	DSP (X8489A0)	
IC023	--	IC	DSPB56371AF180	DSP (X8489A0)	
IC024	--	IC	LD1117STR ADJUSTAB	REGULATOR (X8495A0)	
IC028	--	IC	NJM2068M-D(TE2)	OP AMP (X3505A0)	
-034	--	IC	NJM2068M-D(TE2)	OP AMP (X3505A0)	
IC035	--	IC	PCM1803ADBR	A/D CONVERTER (X7357B0)	
-038	--	IC	PCM1803ADBR	A/D CONVERTER (X7357B0)	
IC039	--	IC	MX25L1605AM2C-12G	FLASH MEMORY (X8718A0)	
IC040	--	IC	SN74LVC00APWR NAND	NAND (X5406A0)	
IC041	--	IC	MAX3221CPWR	RS-232C DRIVER (X2757A0)	
IC042	--	IC	SN74LVC2G74DCTR FL	FLIP FLOP (X8709A0)	
IC043	--	IC	UPSD3354DV-40U6 CP	CPU (X9170A0)	
IC044	--	IC	74LVC169PW,118 4BI	BINARY COUNTER (X8482A0)	
IC045	--	IC	74LVC169PW,118 4BI	BINARY COUNTER (X8482A0)	
IC046	--	IC	SN74LVC157APWR MUL	DATA SELECTOR (X6786A0)	

*: New Parts

RANK: Japan only

CONTROL

REF NO.	PART NO.	DESCRIPTION		REMARKS	QTY
IC047	--	IC	NJM2904V(Te1)	OP AMP (XR532A0)	
IC048	--	IC	NJM2904V(Te1)	OP AMP (XR532A0)	
IC049	--	IC	SN74LV4052APWR	DEMULPLEXER (X6976A0)	
IC050	--	IC	NJM2904V(Te1)	OP AMP (XR532A0)	
IC051	--	IC	SN74LVC157APWR MUL	DATA SELECTOR (X6786A0)	
IC052	--	IC	NJM2904V(Te1)	OP AMP (XR532A0)	
IC054	--	IC	SN74LVC245APWR	BUS TRANSCEIVER (XZ287A0)	
IC055	--	IC	SN74LV541APWRBUS B	BUFFER/DRIVER (X5966A0)	
IC056	--	IC	SN74LV541APWRBUS B	BUFFER/DRIVER (X5966A0)	
IC057	--	IC	SN74LV273APWR D-FF	D-TYPE FLIP FLOP (X5074A0)	
-061	--	IC	SN74LV273APWR D-FF	D-TYPE FLIP FLOP (X5074A0)	
IC062	--	IC	SN74ABT245BNST-EL	BUS TRANSCEIVER (XU009A0)	
IC063	--	IC	SN74LV14APWR INV	INVERTER (X6688A0)	
IC064	--	IC	TC74LCX04FT(EL,K)	INVERTER (X8415A0)	
L001	--	Coil	3.3uH	(WG35380)	
L002	--	Coil	3.3uH	(WG35380)	
L005	--	Coil	47uH	(WH14400)	
R001	--	Carbon Resistor (chip)	0 1/16W J	(RD35000)	
R002	--	Carbon Resistor (chip)	0 1/16W J	(RD35000)	
R003	--	Metal Film Resistor (chip)	4.7K 1/16W D	(RF35647)	
R005	--	Metal Film Resistor (chip)	4.7K 1/16W D	(RF35647)	
R007	--	Metal Film Resistor (chip)	4.7K 1/16W D	(RF35647)	
R009	--	Metal Film Resistor (chip)	4.7K 1/16W D	(RF35647)	
R011	--	Carbon Resistor (chip)	18 1/16W J	(RD35418)	
-014	--	Carbon Resistor (chip)	18 1/16W J	(RD35418)	
R015	--	Metal Film Resistor (chip)	4.7K 1/16W D	(RF35647)	
-018	--	Metal Film Resistor (chip)	4.7K 1/16W D	(RF35647)	
R019	--	Metal Film Resistor (chip)	10K 1/16W D	(RF35710)	
-026	--	Metal Film Resistor (chip)	10K 1/16W D	(RF35710)	
R027	--	Metal Film Resistor (chip)	680 1/16W D	(RF35568)	
-034	--	Metal Film Resistor (chip)	680 1/16W D	(RF35568)	
R035	--	Metal Film Resistor (chip)	100 1/16W D	(RF35510)	
-042	--	Metal Film Resistor (chip)	100 1/16W D	(RF35510)	
R043	--	Carbon Resistor (chip)	100 1/16W J	(RD35510)	
R044	--	Carbon Resistor (chip)	33 1/16W J	(RD35433)	
-046	--	Carbon Resistor (chip)	33 1/16W J	(RD35433)	
R047	--	Carbon Resistor (chip)	0 1/16W J	(RD35000)	
R048	--	Carbon Resistor (chip)	0 1/16W J	(RD35000)	
R049	--	Carbon Resistor (chip)	100 1/16W J	(RD35510)	
R050	--	Carbon Resistor (chip)	33 1/16W J	(RD35433)	
-052	--	Carbon Resistor (chip)	33 1/16W J	(RD35433)	
R053	--	Carbon Resistor (chip)	0 1/16W J	(RD35000)	
R054	--	Carbon Resistor (chip)	0 1/16W J	(RD35000)	
R075	--	Carbon Resistor (chip)	3.0K 1/16W D	(RF35630)	
-086	--	Carbon Resistor (chip)	3.0K 1/16W D	(RF35630)	
R087	--	Carbon Resistor (chip)	1.5K 1/16W D	(RF35615)	
-094	--	Carbon Resistor (chip)	1.5K 1/16W D	(RF35615)	
R095	--	Carbon Resistor (chip)	3.0K 1/16W D	(RF35630)	
-098	--	Carbon Resistor (chip)	3.0K 1/16W D	(RF35630)	
R099	--	Metal Film Resistor (chip)	5.1K 1/16W D	(RF35651)	
-102	--	Metal Film Resistor (chip)	5.1K 1/16W D	(RF35651)	
R107	--	Metal Film Resistor (chip)	5.1K 1/16W D	(RF35651)	
-110	--	Metal Film Resistor (chip)	5.1K 1/16W D	(RF35651)	
R121	--	Carbon Resistor (chip)	10K 1/16W J	(RD35710)	
R122	--	Carbon Resistor (chip)	10K 1/16W J	(RD35710)	
R123	--	Carbon Resistor (chip)	1.0K 1/16W J	(RD35610)	
-126	--	Carbon Resistor (chip)	1.0K 1/16W J	(RD35610)	
R127	--	Carbon Resistor (chip)	0 1/16W J	(RD35000)	
R128	--	Carbon Resistor (chip)	0 1/16W J	(RD35000)	
R129	--	Carbon Resistor (chip)	100 1/16W J	(RD35510)	
R130	--	Carbon Resistor (chip)	22 1/16W J	(RD35422)	
-132	--	Carbon Resistor (chip)	22 1/16W J	(RD35422)	
R133	--	Carbon Resistor (chip)	0 1/16W J	(RD35000)	
R134	--	Carbon Resistor (chip)	0 1/16W J	(RD35000)	
R135	--	Carbon Resistor (chip)	100 1/16W J	(RD35510)	
R136	--	Carbon Resistor (chip)	22 1/16W J	(RD35422)	
-138	--	Carbon Resistor (chip)	22 1/16W J	(RD35422)	
R139	--	Carbon Resistor (chip)	1.0 1/16W J	(RD35310)	

*: New Parts

RANK: Japan only

CONTROL

REF NO.	PART NO.	DESCRIPTION		REMARKS	QTY
R140	--	Carbon Resistor (chip)	120 1/16W J	(RD35512)	
R162	--	Carbon Resistor (chip)	47K 1/16W D	(RF45747)	
-169	--	Carbon Resistor (chip)	47K 1/16W D	(RF45747)	
R170	--	Metal Film Resistor (chip)	4.7K 1/16W D	(RF35647)	
-173	--	Metal Film Resistor (chip)	4.7K 1/16W D	(RF35647)	
R174	--	Carbon Resistor (chip)	33K 1/16W D	(RF45733)	
-177	--	Carbon Resistor (chip)	33K 1/16W D	(RF45733)	
R178	--	Metal Film Resistor (chip)	2.2K 1/16W D	(RF35622)	
-181	--	Metal Film Resistor (chip)	2.2K 1/16W D	(RF35622)	
R182	--	Metal Film Resistor (chip)	4.7K 1/16W D	(RF35647)	
-193	--	Metal Film Resistor (chip)	4.7K 1/16W D	(RF35647)	
R194	--	Metal Film Resistor (chip)	2.2K 1/16W D	(RF35622)	
-197	--	Metal Film Resistor (chip)	2.2K 1/16W D	(RF35622)	
R198	--	Metal Film Resistor (chip)	4.7K 1/16W D	(RF35647)	
-201	--	Metal Film Resistor (chip)	4.7K 1/16W D	(RF35647)	
R202	--	Carbon Resistor (chip)	100 1/16W J	(RD35510)	
-209	--	Carbon Resistor (chip)	100 1/16W J	(RD35510)	
R210	--	Carbon Resistor (chip)	0 1/16W J	(RD35000)	
-213	--	Carbon Resistor (chip)	0 1/16W J	(RD35000)	
R214	--	Carbon Resistor (chip)	33 1/16W J	(RD35433)	
R215	--	Carbon Resistor (chip)	0 1/16W J	(RD35000)	
R216	--	Carbon Resistor (chip)	33 1/16W J	(RD35433)	
R217	--	Carbon Resistor (chip)	0 1/16W J	(RD35000)	
R218	--	Carbon Resistor (chip)	33 1/16W J	(RD35433)	
R219	--	Carbon Resistor (chip)	0 1/16W J	(RD35000)	
R220	--	Carbon Resistor (chip)	33 1/16W J	(RD35433)	
R221	--	Carbon Resistor (chip)	0 1/16W J	(RD35000)	
R222	--	Carbon Resistor (chip)	22 1/16W J	(RD35422)	
R223	--	Carbon Resistor (chip)	100 1/16W J	(RD35510)	
R224	--	Carbon Resistor (chip)	1.0M 1/16W J	(RD35910)	
R225	--	Carbon Resistor (chip)	100 1/16W J	(RD35510)	
R226	--	Carbon Resistor (chip)	22 1/16W J	(RD35422)	
R227	--	Carbon Resistor (chip)	22 1/16W J	(RD35422)	
R228	--	Carbon Resistor (chip)	470 1/16W J	(RD35547)	
R229	--	Carbon Resistor (chip)	100 1/16W J	(RD35510)	
R230	--	Carbon Resistor (chip)	1.0K 1/16W J	(RD35610)	
R231	--	Carbon Resistor (chip)	22 1/16W J	(RD35422)	
R232	--	Carbon Resistor (chip)	22 1/16W J	(RD35422)	
R233	--	Carbon Resistor (chip)	1.0K 1/16W J	(RD35610)	
R234	--	Carbon Resistor (chip)	22 1/16W J	(RD35422)	
R235	--	Carbon Resistor (chip)	1.0K 1/16W J	(RD35610)	
R236	--	Carbon Resistor (chip)	1.0K 1/16W J	(RD35610)	
R237	--	Carbon Resistor (chip)	100 1/16W J	(RD35510)	
R238	--	Carbon Resistor (chip)	0 1/16W J	(RD35000)	
-240	--	Carbon Resistor (chip)	0 1/16W J	(RD35000)	
R241	--	Carbon Resistor (chip)	33K 1/16W J	(RD35733)	
-244	--	Carbon Resistor (chip)	33K 1/16W J	(RD35733)	
R245	--	Carbon Resistor (chip)	1.5K 1/16W J	(RD35615)	
R246	--	Carbon Resistor (chip)	1.5K 1/16W J	(RD35615)	
R247	--	Carbon Resistor (chip)	0 1/16W J	(RD35000)	
R248	--	Carbon Resistor (chip)	0 1/16W J	(RD35000)	
R249	--	Carbon Resistor (chip)	22 1/16W J	(RD35422)	
-251	--	Carbon Resistor (chip)	22 1/16W J	(RD35422)	
R253	--	Carbon Resistor (chip)	10K 1/16W J	(RD35710)	
R254	--	Carbon Resistor (chip)	100K 1/16W J	(RD35810)	
-258	--	Carbon Resistor (chip)	100K 1/16W J	(RD35810)	
R259	--	Carbon Resistor (chip)	1.0K 1/16W J	(RD35610)	
-263	--	Carbon Resistor (chip)	1.0K 1/16W J	(RD35610)	
R264	--	Carbon Resistor (chip)	10K 1/16W J	(RD35710)	
-267	--	Carbon Resistor (chip)	10K 1/16W J	(RD35710)	
R269	--	Carbon Resistor (chip)	0 1/16W J	(RD35000)	
R301	--	Carbon Resistor (chip)	33 1/16W J	(RD35433)	
-303	--	Carbon Resistor (chip)	33 1/16W J	(RD35433)	
R304	--	Carbon Resistor (chip)	100K 1/16W J	(RD35810)	
-306	--	Carbon Resistor (chip)	100K 1/16W J	(RD35810)	
R307	--	Carbon Resistor (chip)	47K 1/16W D	(RF45747)	
R308	--	Carbon Resistor (chip)	47K 1/16W D	(RF45747)	
R309	--	Carbon Resistor (chip)	1.0K 1/16W J	(RD35610)	
-311	--	Carbon Resistor (chip)	1.0K 1/16W J	(RD35610)	
R312	--	Carbon Resistor (chip)	47 1/16W J	(RD35447)	

*: New Parts

RANK: Japan only

CONTROL and INANL and OUTANL

REF NO.	PART NO.	DESCRIPTION		REMARKS	QTY
R313	--	Carbon Resistor (chip)	47 1/16W J	(RD35447)	
R315	--	Carbon Resistor (chip)	47 1/16W J	(RD35447)	
R317	--	Carbon Resistor (chip)	22 1/16W J	(RD35422)	
R318	--	Carbon Resistor (chip)	47K 1/16W J	(RD35747)	
R319	--	Metal Film Resistor (chip)	1.2K 1/16W D	(RF35612)	
-322	--	Metal Film Resistor (chip)	1.2K 1/16W D	(RF35612)	
R323	--	Metal Film Resistor (chip)	22K 1/16W D	(RF35722)	
-326	--	Metal Film Resistor (chip)	22K 1/16W D	(RF35722)	
R327	--	Metal Film Resistor (chip)	5.1K 1/16W D	(RF35651)	
-330	--	Metal Film Resistor (chip)	5.1K 1/16W D	(RF35651)	
R334	--	Carbon Resistor (chip)	22 1/16W J	(RD35422)	
-338	--	Carbon Resistor (chip)	22 1/16W J	(RD35422)	
R339	--	Carbon Resistor (chip)	100K 1/16W J	(RD35810)	
-341	--	Carbon Resistor (chip)	100K 1/16W J	(RD35810)	
R342	--	Carbon Resistor (chip)	0 1/16W J	(RD35000)	
R343	--	Carbon Resistor (chip)	220 1/16W J	(RD35522)	
R344	--	Carbon Resistor (chip)	330 1/16W J	(RD35533)	
-350	--	Carbon Resistor (chip)	330 1/16W J	(RD35533)	
R351	--	Carbon Resistor (chip)	47K 1/16W D	(RF45747)	
R352	--	Carbon Resistor (chip)	47K 1/16W D	(RF45747)	
R353	--	Carbon Resistor (chip)	47 1/16W J	(RD35447)	
R354	--	Carbon Resistor (chip)	47 1/16W J	(RD35447)	
RA001	--	Resistor Array (chip)	22x4 J	(WG88990)	
RA002	--	Resistor Array (chip)	22x4 J	(WG88990)	
RA003	--	Resistor Array (chip)	33x4 J	(WG89030)	
-008	--	Resistor Array (chip)	33x4 J	(WG89030)	
RA009	--	Resistor Array (chip)	150x4 J	(WG89190)	
RA010	--	Resistor Array (chip)	150x4 J	(WG89190)	
SW001	--	Jumper Switch	CHS-01 TA1	(V302690)	
TH001	--	Poly Switch	MINI SMDC020F-2	(VZ42850)	
TH002	--	Poly Switch	MINI SMDC020F-2	(VZ42850)	
TH003	--	Poly Switch	MINISMD110F/16-2	(V739430)	
X001	--	Quartz Crystal Unit	24.576MHz	(V362570)	
X003	--	Quartz Crystal Unit	40.00MHz DSO321SR	(WG97980)	
* *	WJ972700	Circuit Board	INANL	(WJ97330)(X8714C0)	
	WJ972900	Circuit Board	OUTANL	(WJ97330)(X8714C0)	
	--	Earth Film	AN-PA	(WM02630)	
C701	--	Ceramic Capacitor-B (chip)	0.01uF 50V K	(US06410)	
-703	--	Ceramic Capacitor-B (chip)	0.01uF 50V K	(US06410)	
C704	--	Ceramic Capacitor-CH(chip)	22pF 50V J	(US06122)	
-711	--	Ceramic Capacitor-CH(chip)	22pF 50V J	(US06122)	
C712	--	Ceramic Capacitor-CH(chip)	56pF 50V J	(US06156)	
-715	--	Ceramic Capacitor-CH(chip)	56pF 50V J	(US06156)	
C716	--	Ceramic Capacitor-B (chip)	0.01uF 50V K	(US06410)	
C717	--	Ceramic Capacitor-CH(chip)	56pF 50V J	(US06156)	
-720	--	Ceramic Capacitor-CH(chip)	56pF 50V J	(US06156)	
C721	--	Electrolytic Cap.	10uF 50V	(UR86710)	
C722	--	Electrolytic Cap.	10uF 50V	(UR86710)	
C801	--	Mylar Capacitor	0.1uF 250V K	(WB83390)	
-808	--	Mylar Capacitor	0.1uF 250V K	(WB83390)	
C809	--	Monolithic Ceramic Cap.	1000pF 250V K	(WJ83500)	
-816	--	Monolithic Ceramic Cap.	1000pF 250V K	(WJ83500)	
C817	--	Ceramic Capacitor (Chip)	2200pF 250V K	(WH15840)	
-824	--	Ceramic Capacitor (Chip)	2200pF 250V K	(WH15840)	
C829	--	Ceramic Capacitor-B (chip)	0.01uF 50V K	(US06410)	
-832	--	Ceramic Capacitor-B (chip)	0.01uF 50V K	(US06410)	
C833	--	Electrolytic Cap.	10uF 50V	(UR86710)	
C834	--	Electrolytic Cap.	10uF 50V	(UR86710)	
C835	--	Monolithic Ceramic Cap.	4700pF 630V K	(VZ56240)	
-842	--	Monolithic Ceramic Cap.	4700pF 630V K	(VZ56240)	
C843	--	Monolithic Ceramic Cap.	1000pF 630V K	(VZ58560)	
-846	--	Monolithic Ceramic Cap.	1000pF 630V K	(VZ58560)	
CN805	--	Fasten Terminal	16611BL-2	(WA76770)	
-808	--	Fasten Terminal	16611BL-2	(WA76770)	
CN809	--	Base Post	PH 16P TE	(VF28340)	
CN810	--	Base Post	PH 4P TE	(VB39000)	
D701	--	Diode	1SS355 TE-17	(VT33290)	
-708	--	Diode	1SS355 TE-17	(VT33290)	
D801	--	Diode	1SS355 TE-17	(VT33290)	

*: New Parts

RANK: Japan only

INANL and OUTANL and OPT-AN and PN-AN and RS232-GPI and LCD

REF NO.	PART NO.	DESCRIPTION		REMARKS	QTY
-804	--	Diode	1SS355 TE-17	(VT33290)	
IC701	--	IC	NJM2068M-D(TE2)	OP AMP (X3505A0)	
IC702	--	IC	NJM2068M-D(TE2)	OP AMP (X3505A0)	
IC801	--	IC	NJM2068M-D(TE2)	OP AMP (X3505A0)	
IC802	--	IC	NJM2068M-D(TE2)	OP AMP (X3505A0)	
JK701	--	Cannon Connector	JACK NC3FBV1	CH1 INPUT (V986210)	
JK702	--	Cannon Connector	JACK NC3FBV1	CH2 INPUT (V986210)	
JK703	--	Cannon Connector	JACK NC3FBV1	CH3 INPUT (V986210)	
JK704	--	Cannon Connector	JACK NC3FBV1	CH4 INPUT (V986210)	
JK705	--	Cannon Connector	JACK NC3MBV	CH1 LINK OUT (WJ45920)	
JK706	--	Cannon Connector	JACK NC3MBV	CH2 LINK OUT (WJ45920)	
JK707	--	Cannon Connector	JACK NC3MBV	CH3 LINK OUT (WJ45920)	
JK708	--	Cannon Connector	JACK NC3MBV	CH4 LINK OUT (WJ45920)	
K801	--	Terminal Plate	B88	(WE67930)	
L801	--	Coil	1.9uH	(WD40870)	
-804	--	Coil	1.9uH	(WD40870)	
Q801	--	Digital Transistor	KRC102S-RTK/P	(WC43500)	
-804	--	Digital Transistor	KRC102S-RTK/P	(WC43500)	
R701	--	Thick Film Resistor (chip)	10K 1/10W D	(RD55710)	
-708	--	Thick Film Resistor (chip)	10K 1/10W D	(RD55710)	
R709	--	Thick Film Resistor (chip)	2.0K 1/10W D	(RD55620)	
-716	--	Thick Film Resistor (chip)	2.0K 1/10W D	(RD55620)	
R717	--	Carbon Resistor (chip)	120 1/16W J	(RD35512)	
-720	--	Carbon Resistor (chip)	120 1/16W J	(RD35512)	
R801	--	Metal Oxide Film Resistor	2.2 3W J	(WK91630)	
-804	--	Metal Oxide Film Resistor	2.2 3W J	(WK91630)	
R805	--	Metal Oxide Film Resistor	4.7 3W J FORMING	(WD40710)	
-808	--	Metal Oxide Film Resistor	4.7 3W J FORMING	(WD40710)	
R809	--	Flame Proof C. Resistor	4.7 1/4W J	(HV75347)	
-812	--	Flame Proof C. Resistor	4.7 1/4W J	(HV75347)	
R813	--	Carbon Resistor (chip)	33K 1/16W D	(RF45733)	
-815	--	Carbon Resistor (chip)	33K 1/16W D	(RF45733)	
R816	--	Carbon Resistor (chip)	4.7K 1/16W D	(RF45647)	
R817	--	Carbon Resistor (chip)	33K 1/16W D	(RF45733)	
-819	--	Carbon Resistor (chip)	33K 1/16W D	(RF45733)	
R820	--	Carbon Resistor (chip)	4.7K 1/16W D	(RF45647)	
R821	--	Carbon Resistor (chip)	33K 1/16W D	(RF45733)	
-823	--	Carbon Resistor (chip)	33K 1/16W D	(RF45733)	
R824	--	Carbon Resistor (chip)	4.7K 1/16W D	(RF45647)	
R825	--	Carbon Resistor (chip)	33K 1/16W D	(RF45733)	
-827	--	Carbon Resistor (chip)	33K 1/16W D	(RF45733)	
R828	--	Carbon Resistor (chip)	4.7K 1/16W D	(RF45647)	
R829	--	Carbon Resistor (chip)	18 1/16W J	(RD35418)	
-832	--	Carbon Resistor (chip)	18 1/16W J	(RD35418)	
R837	--	Flame Proof C. Resistor	1.0 1/4W J	(HV75310)	
-840	--	Flame Proof C. Resistor	1.0 1/4W J	(HV75310)	
RY801	--	Relay	DC DI24D1-O(M)	(WJ56900)	
RY803	--	Relay	DC DI24D1-O(M)	(WJ56900)	
RY805	--	Relay	DC DI24D1-O(M)	(WJ56900)	
RY807	--	Relay	DC DI24D1-O(M)	(WJ56900)	
SP801	--	Receptacle	NL4MD-H	Speakon A (V818170)	
SP802	--	Receptacle	NL4MD-H	Speakon B (V818170)	
SP803	--	Receptacle	NL4MD-H	Speakon C (V818170)	
SP804	--	Receptacle	NL4MD-H	Speakon D (V818170)	
W701	--	Connector Assembly SIG-IN	B&C 13P 330mm	(WK02070)	
W801	--	Connector Assembly OUTPS	B&C TUBE 5P 420mm	(WK14200)	
W802	--	Connector Assembly	B&C 1P 530mm BK	(WK16820)	
W805	--	Connector Assembly	B&C 1P 530mm BK	(WK16820)	
XX801	--	Current Sensor	L18P020D15	(WJ45850)	
-804	--	Current Sensor	L18P020D15	(WJ45850)	
*	WJ971500	Circuit Board	OPT-AN	(WJ97170)(X8711C0)	
*	WJ971300	Circuit Board	PN-AN	(WJ97170)(X8711C0)	
*	WJ971400	Circuit Board	RS232-GPI	(WJ97170)(X8711C0)	
*	WK624200	Circuit Board	LCD	(WJ97170)(X8711C0)	
C001	--	Ceramic Capacitor-B (chip)	0.01uF 50V K	(US06410)	
-003	--	Ceramic Capacitor-B (chip)	0.01uF 50V K	(US06410)	
C004	--	Ceramic Capacitor-B (chip)	0.047uF 16V K	(US03447)	
C005	--	Ceramic Capacitor-F (chip)	0.1uF 50V Z	(US06510)	
-009	--	Ceramic Capacitor-F (chip)	0.1uF 50V Z	(US06510)	

*: New Parts

RANK: Japan only

OPT-AN and PN-AN and RS232-GPI and LCD

REF NO.	PART NO.	DESCRIPTION		REMARKS	QTY
C201	--	Ceramic Capacitor-F (chip)	0.1uF 50V Z	(US06510)	
-203	--	Ceramic Capacitor-F (chip)	0.1uF 50V Z	(US06510)	
CN001	--	FFC Connector	52271-3079 P=1mm	(WJ85350)	
CN002	--	Connector	MTLW 16P	(WK74020)	
CN201	--	FFC Connector	52271-3079 P=1mm	(WJ85350)	
CN202	--	D Sub Connector	J 9P	RS232 (WK51820)	
CN203	--	D Sub Connector	J 25P	GPI (WK51830)	
CN301	--	Connector	FMN 40P	(WC19900)	
CN302	--	Plug	PHEC 80P	(V915200)	
EC001	--	Rotary Encoder	EC11B20204AP	ENCODER (WK80260)	
EM201	--	EMI Filter (chip)	NFM3DCC101U1H3L	(VQ76140)	
EM202	--	EMI LC Filter	NFA31CC101S1E4D	(WC39150)	
-205	--	EMI LC Filter	NFA31CC101S1E4D	(WC39150)	
IC001	--	IC	SN74LV541APWRBUS B	BUFFER/DRIVER (X5966A0)	
IC002	--	IC	74HCT273PW,118 D-F	D-TYPE FLIP FLOP (X8681A0)	
IC003	--	IC	74HCT273PW,118 D-F	D-TYPE FLIP FLOP (X8681A0)	
IC004	--	IC	74HCT4514PW,118 4T	DECODER (X8630A0)	
-007	--	IC	74HCT4514PW,118 4T	DECODER (X8630A0)	
LD001	--	LED Green (chip)	GREEN SML-512MW	SIGNAL-CH1 (WJ83350)	
LD002	--	LED Green (chip)	GREEN SML-512MW	SIGNAL-CH2 (WJ83350)	
LD003	--	LED Green (chip)	GREEN SML-512MW	SIGNAL-CH3 (WJ83350)	
LD004	--	LED Green (chip)	GREEN SML-512MW	SIGNAL-CH4 (WJ83350)	
LD005	--	LED Yellow (chip)	YELLOW SML-512WW	PROTECT-CH1 (WG96210)	
LD006	--	LED Yellow (chip)	YELLOW SML-512WW	PROTECT-CH2 (WG96210)	
LD007	--	LED Yellow (chip)	YELLOW SML-512WW	PROTECT-CH3 (WG96210)	
LD008	--	LED Yellow (chip)	YELLOW SML-512WW	PROTECT-CH4 (WG96210)	
LD009	--	LED Red (chip)	SML-512UW	PEAK-CH1 (WD11160)	
LD010	--	LED Red (chip)	SML-512UW	PEAK-CH2 (WD11160)	
LD011	--	LED Red (chip)	SML-512UW	PEAK-CH3 (WD11160)	
LD012	--	LED Red (chip)	SML-512UW	PEAK-CH4 (WD11160)	
LD013	--	LED Green (chip)	GREEN SML-512MW	POWER (WJ83350)	
LD014	--	LED Yellow (chip)	YELLOW SML-512WW	STANDBY (WG96210)	
LD015	--	LED Red (chip)	SML-512UW	AMP-PROTECT (WD11160)	
LD016	--	LED White (chip)	WHITE SMLE12WBC7W	CH1-VOL.1 (WK27910)	
LD017	--	LED White (chip)	WHITE SMLE12WBC7W	CH1-VOL.2 (WK27910)	
LD018	--	LED White (chip)	WHITE SMLE12WBC7W	CH1-VOL.3 (WK27910)	
LD019	--	LED White (chip)	WHITE SMLE12WBC7W	CH1-VOL.4 (WK27910)	
LD020	--	LED White (chip)	WHITE SMLE12WBC7W	CH1-VOL.5 (WK27910)	
LD021	--	LED White (chip)	WHITE SMLE12WBC7W	CH1-VOL.6 (WK27910)	
LD022	--	LED White (chip)	WHITE SMLE12WBC7W	CH1-VOL.7 (WK27910)	
LD023	--	LED White (chip)	WHITE SMLE12WBC7W	CH1-VOL.8 (WK27910)	
LD024	--	LED White (chip)	WHITE SMLE12WBC7W	CH1-VOL.9 (WK27910)	
LD025	--	LED White (chip)	WHITE SMLE12WBC7W	CH1-VOL.10 (WK27910)	
LD026	--	LED White (chip)	WHITE SMLE12WBC7W	CH1-VOL.11 (WK27910)	
LD027	--	LED White (chip)	WHITE SMLE12WBC7W	CH1-VOL.12 (WK27910)	
LD028	--	LED White (chip)	WHITE SMLE12WBC7W	CH1-VOL.13 (WK27910)	
LD029	--	LED White (chip)	WHITE SMLE12WBC7W	CH1-VOL.14 (WK27910)	
LD030	--	LED Blue (chip)	BLUE SMLE12BC7T	CH1-VOL.15 (WK15110)	
LD032	--	LED White (chip)	WHITE SMLE12WBC7W	CH2-VOL.1 (WK27910)	
LD033	--	LED White (chip)	WHITE SMLE12WBC7W	CH2-VOL.2 (WK27910)	
LD034	--	LED White (chip)	WHITE SMLE12WBC7W	CH2-VOL.3 (WK27910)	
LD035	--	LED White (chip)	WHITE SMLE12WBC7W	CH2-VOL.4 (WK27910)	
LD036	--	LED White (chip)	WHITE SMLE12WBC7W	CH2-VOL.5 (WK27910)	
LD037	--	LED White (chip)	WHITE SMLE12WBC7W	CH2-VOL.6 (WK27910)	
LD038	--	LED White (chip)	WHITE SMLE12WBC7W	CH2-VOL.7 (WK27910)	
LD039	--	LED White (chip)	WHITE SMLE12WBC7W	CH2-VOL.8 (WK27910)	
LD040	--	LED White (chip)	WHITE SMLE12WBC7W	CH2-VOL.9 (WK27910)	
LD041	--	LED White (chip)	WHITE SMLE12WBC7W	CH2-VOL.10 (WK27910)	
LD042	--	LED White (chip)	WHITE SMLE12WBC7W	CH2-VOL.11 (WK27910)	
LD043	--	LED White (chip)	WHITE SMLE12WBC7W	CH2-VOL.12 (WK27910)	
LD044	--	LED White (chip)	WHITE SMLE12WBC7W	CH2-VOL.13 (WK27910)	
LD045	--	LED White (chip)	WHITE SMLE12WBC7W	CH2-VOL.14 (WK27910)	
LD046	--	LED Blue (chip)	BLUE SMLE12BC7T	CH2-VOL.15 (WK15110)	
LD048	--	LED White (chip)	WHITE SMLE12WBC7W	CH3-VOL.1 (WK27910)	
LD049	--	LED White (chip)	WHITE SMLE12WBC7W	CH3-VOL.2 (WK27910)	
LD050	--	LED White (chip)	WHITE SMLE12WBC7W	CH3-VOL.3 (WK27910)	
LD051	--	LED White (chip)	WHITE SMLE12WBC7W	CH3-VOL.4 (WK27910)	
LD052	--	LED White (chip)	WHITE SMLE12WBC7W	CH3-VOL.5 (WK27910)	
LD053	--	LED White (chip)	WHITE SMLE12WBC7W	CH3-VOL.6 (WK27910)	
LD054	--	LED White (chip)	WHITE SMLE12WBC7W	CH3-VOL.7 (WK27910)	

*: New Parts

RANK: Japan only

OPT-AN and PN-AN and RS232-GPI and LCD and PAANL

REF NO.	PART NO.	DESCRIPTION		REMARKS	QTY
LD055	--	LED White (chip)	WHITE SMLE12WBC7W	CH3-VOL.8	(WK27910)
LD056	--	LED White (chip)	WHITE SMLE12WBC7W	CH3-VOL.9	(WK27910)
LD057	--	LED White (chip)	WHITE SMLE12WBC7W	CH3-VOL.10	(WK27910)
LD058	--	LED White (chip)	WHITE SMLE12WBC7W	CH3-VOL.11	(WK27910)
LD059	--	LED White (chip)	WHITE SMLE12WBC7W	CH3-VOL.12	(WK27910)
LD060	--	LED White (chip)	WHITE SMLE12WBC7W	CH3-VOL.13	(WK27910)
LD061	--	LED White (chip)	WHITE SMLE12WBC7W	CH3-VOL.14	(WK27910)
LD062	--	LED Blue (chip)	BLUE SMLE12BC7T	CH3-VOL.15	(WK15110)
LD064	--	LED White (chip)	WHITE SMLE12WBC7W	CH4-VOL.1	(WK27910)
LD065	--	LED White (chip)	WHITE SMLE12WBC7W	CH4-VOL.2	(WK27910)
LD066	--	LED White (chip)	WHITE SMLE12WBC7W	CH4-VOL.3	(WK27910)
LD067	--	LED White (chip)	WHITE SMLE12WBC7W	CH4-VOL.4	(WK27910)
LD068	--	LED White (chip)	WHITE SMLE12WBC7W	CH4-VOL.5	(WK27910)
LD069	--	LED White (chip)	WHITE SMLE12WBC7W	CH4-VOL.6	(WK27910)
LD070	--	LED White (chip)	WHITE SMLE12WBC7W	CH4-VOL.7	(WK27910)
LD071	--	LED White (chip)	WHITE SMLE12WBC7W	CH4-VOL.8	(WK27910)
LD072	--	LED White (chip)	WHITE SMLE12WBC7W	CH4-VOL.9	(WK27910)
LD073	--	LED White (chip)	WHITE SMLE12WBC7W	CH4-VOL.10	(WK27910)
LD074	--	LED White (chip)	WHITE SMLE12WBC7W	CH4-VOL.11	(WK27910)
LD075	--	LED White (chip)	WHITE SMLE12WBC7W	CH4-VOL.12	(WK27910)
LD076	--	LED White (chip)	WHITE SMLE12WBC7W	CH4-VOL.13	(WK27910)
LD077	--	LED White (chip)	WHITE SMLE12WBC7W	CH4-VOL.14	(WK27910)
LD078	--	LED Blue (chip)	BLUE SMLE12BC7T	CH4-VOL.15	(WK15110)
R001	--	Carbon Resistor (chip)	330 1/4W J		(RD15533)
-004	--	Carbon Resistor (chip)	330 1/4W J		(RD15533)
R005	--	Carbon Resistor (chip)	10K 1/16W J		(RD35710)
-014	--	Carbon Resistor (chip)	10K 1/16W J		(RD35710)
R015	--	Carbon Resistor (chip)	150 1/4W J		(RD15515)
-018	--	Carbon Resistor (chip)	150 1/4W J		(RD15515)
R019	--	Carbon Resistor (chip)	220 1/4W J		(RD15522)
-026	--	Carbon Resistor (chip)	220 1/4W J		(RD15522)
R027	--	Carbon Resistor (chip)	150 1/4W J		(RD15515)
R028	--	Carbon Resistor (chip)	220 1/4W J		(RD15522)
R029	--	Carbon Resistor (chip)	220 1/4W J		(RD15522)
R030	--	Carbon Resistor (chip)	56 1/16W J		(RD35456)
R031	--	Carbon Resistor (chip)	56 1/16W J		(RD35456)
R033	--	Carbon Resistor (chip)	680 1/16W J		(RD35568)
-092	--	Carbon Resistor (chip)	680 1/16W J		(RD35568)
R101	--	Carbon Resistor (chip)	330 1/16W J		(RD35533)
-110	--	Carbon Resistor (chip)	330 1/16W J		(RD35533)
R111	--	Carbon Resistor (chip)	330 1/4W J		(RD15533)
-114	--	Carbon Resistor (chip)	330 1/4W J		(RD15533)
R115	--	Carbon Resistor (chip)	33 1/16W J		(RD35433)
-117	--	Carbon Resistor (chip)	33 1/16W J		(RD35433)
R118	--	Carbon Resistor (chip)	0 1/16W J		(RD35000)
RA001	--	Resistor Array (chip)	150x4 J		(WG89190)
-012	--	Resistor Array (chip)	150x4 J		(WG89190)
SW001	--	Tact Switch	SKRGAED010	VOL-A	(WE95200)
SW002	--	Tact Switch	SKRGAED010	VOL-B	(WE95200)
SW003	--	Push Switch	LS22BB-2UR/UR-T	MUTE-CH1	(WK74000)
SW004	--	Push Switch	LS22BB-2UR/UR-T	MUTE-CH2	(WK74000)
SW005	--	Push Switch	LS22BB-2UR/UR-T	MUTE-CH3	(WK74000)
SW006	--	Push Switch	LS22BB-2UR/UR-T	MUTE-CH4	(WK74000)
SW007	--	Tact Switch	SKRGAED010	SELECT-CH1	(WE95200)
SW008	--	Tact Switch	SKRGAED010	SELECT-CH2	(WE95200)
SW009	--	Tact Switch	SKRGAED010	SELECT-CH3	(WE95200)
SW010	--	Tact Switch	SKRGAED010	SELECT-CH4	(WE95200)
*	WJ972500	Circuit Board	PAANL	(WJ97310)(X8713D0)	
C401	--	Electrolytic Cap.	1.0uF 50V		(UR86610)
C402	--	Mylar Capacitor	1500pF 50V J		(UA65315)
C403	--	Mylar Capacitor	1500pF 50V J		(UA65315)
C404	--	Electrolytic Cap.	10uF 50V		(UR86710)
C407	--	Electrolytic Cap.	470uF 10V		(UU22847)
C408	--	Electrolytic Cap.	470uF 10V		(UU22847)
C409	--	Ceramic Capacitor (CH)	22pF 500V C		(WG21170)
C410	--	Mylar Capacitor	4700pF 50V J		(UA65347)
C411	--	Ceramic Capacitor (CH)	22pF 500V C		(WG21170)
C412	--	Mylar Capacitor	4700pF 50V J		(UA65347)
C413	--	Ceramic Capacitor-F (chip)	0.1uF 50V Z		(US06510)

*: New Parts

RANK: Japan only

PAANL

REF NO.	PART NO.	DESCRIPTION		REMARKS	QTY
C414	--	Ceramic Capacitor-F (chip)	0.1uF 50V Z	(US06510)	
C415	--	Monolithic Ceramic Cap.	22pF 630V J	(WJ59260)	
C416	--	Electrolytic Cap.	10uF 50V	(UR86710)	
C417	--	Monolithic Ceramic Cap.	22pF 630V J	(WJ59260)	
C418	--	Monolithic Ceramic Cap.	22pF 630V J	(WJ59260)	
C419	--	Electrolytic Cap.	10uF 50V	(UR86710)	
C420	--	Monolithic Ceramic Cap.	22pF 630V J	(WJ59260)	
C421	--	Electrolytic Cap.	4.7uF 100V	(UR89647)	
-424	--	Electrolytic Cap.	4.7uF 100V	(UR89647)	
C425	--	Monolithic Mylar Capacitor	0.1uF 50V	(VR16830)	
-428	--	Monolithic Mylar Capacitor	0.1uF 50V	(VR16830)	
C429	--	Monolithic Ceramic Cap.	22pF 630V J	(WJ59260)	
-432	--	Monolithic Ceramic Cap.	22pF 630V J	(WJ59260)	
C433	--	Mylar Capacitor	0.01uF 50V J	(UA65410)	
-436	--	Mylar Capacitor	0.01uF 50V J	(UA65410)	
C437	--	Electrolytic Cap.	2.2uF 250V	(WJ45880)	
C438	--	Electrolytic Cap.	2.2uF 250V	(WJ45880)	
C439	--	Monolithic Ceramic Cap.	100pF 250V J	(WJ59270)	
C440	--	Monolithic Ceramic Cap.	100pF 250V J	(WJ59270)	
C441	--	Polypropylene Capacitor	3.3uF 250V J	(WJ45970)	
C442	--	Polypropylene Capacitor	3.3uF 250V J	(WJ45970)	
C443	--	Ceramic Capacitor (Chip)	2200pF 250V K	(WH15840)	
C444	--	Ceramic Capacitor (Chip)	2200pF 250V K	(WH15840)	
C445	--	Electrolytic Cap.	47uF 35V	(WM44870)	
C446	--	Electrolytic Cap.	47uF 35V	(UR85747)	
C447	--	Electrolytic Cap.	10uF 50V	(UR86710)	
C448	--	Electrolytic Cap.	100uF 35V	(UR85810)	
C449	--	Mylar Capacitor	0.01uF 50V J	(UA65410)	
C450	--	Monolithic Ceramic Cap.	100pF 250V J	(WJ59270)	
C451	--	Monolithic Ceramic Cap.	100pF 250V J	(WJ59270)	
C452	--	Electrolytic Cap.	150uF 160V	(WK76610)	
C453	--	Electrolytic Cap.	150uF 160V	(WK76610)	
C454	--	Electrolytic Cap.	2.2uF 250V	(WJ45880)	
C455	--	Electrolytic Cap.	2.2uF 250V	(WJ45880)	
C456	--	Ceramic Capacitor (Chip)	2200pF 250V K	(WH15840)	
C457	--	Electrolytic Cap.	2.2uF 250V	(WJ45880)	
-460	--	Electrolytic Cap.	2.2uF 250V	(WJ45880)	
C461	--	Ceramic Capacitor-B (Chip)	0.01uF 50V K	(US06410)	
CN401	--	Connector Base Post	PH 5P TE	(VB39010)	
CN403	--	Connector Base Post	PH 5P TE	(VB39010)	
CN405	--	Connector Base Post	PH 2P TE	(VB38980)	
CN406	--	Connector Base Post	PH 2P TE	(VB38980)	
D401	--	Diode	1SS355 TE-17	(VT33290)	
-404	--	Diode	1SS355 TE-17	(VT33290)	
D405	--	Zener Diode	UDZS3.9BTE-17 3.9V	(VU17160)	
D406	--	Diode	1SS355 TE-17	(VT33290)	
D407	--	Diode	1SS355 TE-17	(VT33290)	
D408	--	Zener Diode	UDZS3.9BTE-17 3.9V	(VU17160)	
D409	--	Diode	1SS355 TE-17	(VT33290)	
-414	--	Diode	1SS355 TE-17	(VT33290)	
D415	--	Zener Diode	UDZS3.9BTE-17 3.9V	(VU17160)	
D416	--	Zener Diode	UDZS6.8BTE-17 6.8V	(VU17220)	
D417	--	Diode (chip)	HSU83	(WD84430)	
D418	--	Diode (chip)	HSU83	(WD84430)	
D419	--	Zener Diode	UDZS6.8BTE-17 6.8V	(VU17220)	
D420	--	Zener Diode	UDZS3.9BTE-17 3.9V	(VU17160)	
D421	--	Zener Diode	UDZS3.9BTE-17 3.9V	(VU17160)	
D422	--	Zener Diode	UDZS6.8BTE-17 6.8V	(VU17220)	
D423	--	Diode (chip)	HSU83	(WD84430)	
D424	--	Diode (chip)	HSU83	(WD84430)	
D425	--	Zener Diode	UDZS6.8BTE-17 6.8V	(VU17220)	
D426	--	Zener Diode	UDZS3.9BTE-17 3.9V	(VU17160)	
D427	--	Diode	D1FK60-5063	(WJ45930)	
-430	--	Diode	D1FK60-5063	(WJ45930)	
D431	--	Diode (chip)	HSU83	(WD84430)	
-438	--	Diode (chip)	HSU83	(WD84430)	
D439	--	Diode	1SS355 TE-17	(VT33290)	
-442	--	Diode	1SS355 TE-17	(VT33290)	
D443	--	Diode (chip)	D1F60 1A 600V	(VS20110)	
-448	--	Diode (chip)	D1F60 1A 600V	(VS20110)	

*: New Parts

RANK: Japan only

PAANL

REF NO.	PART NO.	DESCRIPTION	REMARKS	QTY
D449	--	Zener Diode	UDZS15B TE-17 15V	(VU17300)
D450	--	Diode	1SS355 TE-17	(VT33290)
-453	--	Diode	1SS355 TE-17	(VT33290)
D454	--	Zener Diode	UDZS15B TE-17 15V	(VU17300)
D455	--	Zener Diode	UDZS15B TE-17 15V	(VU17300)
D456	--	Zener Diode	UDZS5.6BTE-17 5.6V	(VU17200)
D457	--	Diode	AG01A WS	(V862980)
L401	--	Coil	100uH H-20	(V466830)
L402	--	Coil	100uH H-20	(V466830)
L403	--	Coil	1.7uH	(WD40880)
L404	--	Coil	1.7uH	(WD40880)
Q401	--	Transistor	2SA1037AK Q,R,S	(VV55650)
Q402	--	Digital Transistor	KRC102S-RTK/P	(WC43500)
Q403	--	Transistor	2SA1037AK Q,R,S	(VV55650)
Q404	--	Digital Transistor	KRC102S-RTK/P	(WC43500)
-406	--	Digital Transistor	KRC102S-RTK/P	(WC43500)
Q407	--	Transistor	2SA1371 D,E	(VU41840)
Q408	--	Transistor (chip)	2SC3324 GR,BL	(V742170)
Q409	--	Transistor	2SA1371 D,E	(VU41840)
Q410	--	Transistor (chip)	2SC3324 GR,BL	(V742170)
Q413	--	Transistor	2SA1371 D,E	(VU41840)
Q414	--	Transistor	2SA1371 D,E	(VU41840)
Q415	--	Transistor	2SC3468 D,E	(VU41860)
Q416	--	Transistor	2SC3468 D,E	(VU41860)
Q417	--	Transistor	2SA1371 D,E	(VU41840)
Q418	--	Transistor (chip)	2SC3324 GR,BL	(V742170)
Q419	--	Transistor	2SA1371 D,E	(VU41840)
Q420	--	Transistor (chip)	2SC3324 GR,BL	(V742170)
Q421	--	Transistor	2SA1371 D,E	(VU41840)
Q422	--	Transistor	2SC3468 D,E	(VU41860)
Q423	--	Transistor (chip)	2SC3324 GR,BL	(V742170)
Q424	--	Transistor	2SA1371 D,E	(VU41840)
Q425	--	Transistor	2SC3468 D,E	(VU41860)
Q426	--	Transistor (chip)	2SC3324 GR,BL	(V742170)
Q427	--	Transistor	2SC5866TL Q,R TA	(WJ46640)
Q428	--	Transistor	2SA2094TL Q TA	(WJ46630)
Q429	--	Transistor	2SC5866TL Q,R TA	(WJ46640)
Q430	--	Transistor	2SA2094TL Q TA	(WJ46630)
Q431	--	Transistor	2SC3468 D,E	(VU41860)
Q432	--	Transistor	2SA1371 D,E	(VU41840)
Q433	--	Transistor	2SC3468 D,E	(VU41860)
Q434	--	Transistor	2SA1371 D,E	(VU41840)
Q435	--	Transistor	2SC3468 D,E	(VU41860)
Q436	--	Transistor	2SA1371 D,E	(VU41840)
Q437	--	Transistor	2SA2094TL Q TA	(WJ46630)
Q438	--	Transistor	2SA1371 D,E	(VU41840)
Q439	--	Transistor	2SC3468 D,E	(VU41860)
Q440	--	Transistor	2SC5866TL Q,R TA	(WJ46640)
Q441	--	Transistor	2SC5866TL Q,R TA	(WJ46640)
Q442	--	Transistor	2SA2094TL Q TA	(WJ46630)
Q443	--	Transistor	2SA2094TL Q TA	(WJ46630)
Q444	--	Transistor	2SC5866TL Q,R TA	(WJ46640)
Q445	--	Transistor	2SA2094TL Q TA	(WJ46630)
Q446	--	Transistor	2SC5866TL Q,R TA	(WJ46640)
Q447	--	Transistor	2SA2094TL Q TA	(WJ46630)
R401	--	Carbon Resistor (chip)	150 1/16W J	(RD35515)
R402	--	Carbon Resistor (chip)	150 1/16W J	(RD35515)
R403	--	Carbon Resistor (chip)	12K 1/16W J	(RD35712)
R404	--	Carbon Resistor (chip)	12K 1/16W J	(RD35712)
R405	--	Thick Film Resistor (chip)	330 1/10W D	(RD55533)
R406	--	Carbon Resistor (chip)	12K 1/16W J	(RD35712)
R407	--	Carbon Resistor (chip)	12K 1/16W J	(RD35712)
R408	--	Thick Film Resistor (chip)	330 1/10W D	(RD55533)
R409	--	Carbon Resistor (chip)	220K 1/4W J	(RD15822)
R410	--	Carbon Resistor (chip)	220K 1/4W J	(RD15822)
R411	--	Carbon Resistor (chip)	220 1/16W J	(RD35522)
R412	--	Carbon Resistor (chip)	1.2K 1/16W J	(RD35612)
R413	--	Carbon Resistor (chip)	220 1/16W J	(RD35522)
R414	--	Carbon Resistor (chip)	1.2K 1/16W J	(RD35612)
-416	--	Carbon Resistor (chip)	1.2K 1/16W J	(RD35612)

*: New Parts

RANK: Japan only

PAANL

REF NO.	PART NO.	DESCRIPTION		REMARKS	QTY
R417	--	Carbon Resistor (chip)	47K 1/16W J	(RD35747)	
R418	--	Carbon Resistor (chip)	47K 1/16W J	(RD35747)	
R419	--	Carbon Resistor (chip)	220 1/16W J	(RD35522)	
R420	--	Carbon Resistor (chip)	390 1/16W J	(RD35539)	
R421	--	Carbon Resistor (chip)	1.2K 1/16W J	(RD35612)	
R422	--	Carbon Resistor (chip)	220 1/16W J	(RD35522)	
R423	--	Carbon Resistor (chip)	390 1/16W J	(RD35539)	
R424	--	Carbon Resistor (chip)	1.2K 1/16W J	(RD35612)	
R425	--	Carbon Resistor	12K 1/3W F	(WE45760)	
-428	--	Carbon Resistor	12K 1/3W F	(WE45760)	
R429	--	Carbon Resistor (chip)	220 1/16W J	(RD35522)	
R430	--	Carbon Resistor (chip)	220 1/16W J	(RD35522)	
R431	--	Carbon Resistor (chip)	47K 1/4W J	(RD15747)	
-438	--	Carbon Resistor (chip)	47K 1/4W J	(RD15747)	
R439	--	Carbon Resistor (chip)	470 1/16W D	(RF45547)	
R440	--	Carbon Resistor (chip)	470 1/16W D	(RF45547)	
R441	--	Carbon Resistor (chip)	100 1/16W J	(RD35510)	
-444	--	Carbon Resistor (chip)	100 1/16W J	(RD35510)	
R445	--	Carbon Resistor (chip)	390 1/16W D	(RF45539)	
R446	--	Carbon Resistor (chip)	15 1/16W D	(RF45415)	
R447	--	Carbon Resistor (chip)	1.8K 1/16W J	(RD35618)	
R448	--	Carbon Resistor (chip)	390 1/16W D	(RF45539)	
R449	--	Carbon Resistor (chip)	15 1/16W D	(RF45415)	
R450	--	Carbon Resistor (chip)	1.8K 1/16W J	(RD35618)	
R451	--	Carbon Resistor (chip)	150 1/4W J	(RD15515)	
-454	--	Carbon Resistor (chip)	150 1/4W J	(RD15515)	
R455	--	Carbon Resistor (chip)	470 1/4W J	(RD15547)	
-458	--	Carbon Resistor (chip)	470 1/4W J	(RD15547)	
R459	--	Carbon Resistor (chip)	22K 1/4W J	(RD15722)	
-471	--	Carbon Resistor (chip)	22K 1/4W J	(RD15722)	
R472	--	Carbon Resistor (chip)	4.7 1/16W J	(RD35347)	
R473	--	Carbon Resistor (chip)	4.7 1/16W J	(RD35347)	
R474	--	Carbon Resistor (chip)	22K 1/4W J	(RD15722)	
R475	--	Carbon Resistor (chip)	22K 1/4W J	(RD15722)	
R476	--	Carbon Resistor (chip)	4.7 1/16W J	(RD35347)	
R477	--	Carbon Resistor (chip)	4.7 1/16W J	(RD35347)	
R478	--	Carbon Resistor (chip)	22K 1/4W J	(RD15722)	
R479	--	Carbon Resistor (chip)	3.3K 1/16W J	(RD35633)	
-482	--	Carbon Resistor (chip)	3.3K 1/16W J	(RD35633)	
R483	--	Carbon Resistor (chip)	91K 1/16W J	(RD35791)	
-486	--	Carbon Resistor (chip)	91K 1/16W J	(RD35791)	
R487	--	Carbon Resistor (chip)	1.8K 1/16W J	(RD35618)	
-490	--	Carbon Resistor (chip)	1.8K 1/16W J	(RD35618)	
R491	--	Carbon Resistor (chip)	330 1/4W J	(RD15533)	
-494	--	Carbon Resistor (chip)	330 1/4W J	(RD15533)	
R495	--	Carbon Resistor (chip)	220 1/16W J	(RD35522)	
-498	--	Carbon Resistor (chip)	220 1/16W J	(RD35522)	
R499	--	Carbon Resistor (chip)	22 1/4W J	(RD15422)	
-502	--	Carbon Resistor (chip)	22 1/4W J	(RD15422)	
R503	--	Carbon Resistor (chip)	2.2 1/16W J	(RD35322)	
R504	--	Carbon Resistor (chip)	22 1/16W J	(RD35422)	
R505	--	Carbon Resistor (chip)	22 1/16W J	(RD35422)	
R506	--	Carbon Resistor (chip)	2.2 1/16W J	(RD35322)	
R507	--	Carbon Resistor (chip)	2.2 1/16W J	(RD35322)	
R508	--	Carbon Resistor (chip)	22 1/16W J	(RD35422)	
R509	--	Carbon Resistor (chip)	22 1/16W J	(RD35422)	
R510	--	Carbon Resistor (chip)	2.2 1/16W J	(RD35322)	
R511	--	Wire Wound Resistor	0.22 5W K	(V483320)	
-514	--	Wire Wound Resistor	0.22 5W K	(V483320)	
R515	--	Carbon Resistor (chip)	2.2 1/16W J	(RD35322)	
R516	--	Carbon Resistor (chip)	22 1/16W J	(RD35422)	
R517	--	Carbon Resistor (chip)	22 1/16W J	(RD35422)	
R518	--	Carbon Resistor (chip)	2.2 1/16W J	(RD35322)	
R519	--	Carbon Resistor (chip)	2.2 1/16W J	(RD35322)	
R520	--	Carbon Resistor (chip)	22 1/16W J	(RD35422)	
R521	--	Carbon Resistor (chip)	22 1/16W J	(RD35422)	
R522	--	Carbon Resistor (chip)	2.2 1/16W J	(RD35322)	
R523	--	Wire Wound Resistor	0.22 5W K	(V483320)	
-526	--	Wire Wound Resistor	0.22 5W K	(V483320)	
R527	--	Carbon Resistor (chip)	2.2 1/16W J	(RD35322)	

*: New Parts

RANK: Japan only

PAANL

REF NO.	PART NO.	DESCRIPTION		REMARKS	QTY
R528	--	Carbon Resistor (chip)	22 1/16W J	(RD35422)	
R529	--	Carbon Resistor (chip)	22 1/16W J	(RD35422)	
R530	--	Carbon Resistor (chip)	2.2 1/16W J	(RD35322)	
R531	--	Carbon Resistor (chip)	2.2 1/16W J	(RD35322)	
R532	--	Carbon Resistor (chip)	22 1/16W J	(RD35422)	
R533	--	Carbon Resistor (chip)	22 1/16W J	(RD35422)	
R534	--	Carbon Resistor (chip)	2.2 1/16W J	(RD35322)	
R535	--	Wire Wound Resistor	0.22 5W K	(V483320)	
-538	--	Wire Wound Resistor	0.22 5W K	(V483320)	
R539	--	Carbon Resistor (chip)	2.2 1/16W J	(RD35322)	
R540	--	Carbon Resistor (chip)	22 1/16W J	(RD35422)	
R541	--	Carbon Resistor (chip)	22 1/16W J	(RD35422)	
R542	--	Carbon Resistor (chip)	2.2 1/16W J	(RD35322)	
R543	--	Carbon Resistor (chip)	2.2 1/16W J	(RD35322)	
R544	--	Carbon Resistor (chip)	22 1/16W J	(RD35422)	
R545	--	Carbon Resistor (chip)	22 1/16W J	(RD35422)	
R546	--	Carbon Resistor (chip)	2.2 1/16W J	(RD35322)	
R547	--	Wire Wound Resistor	0.22 5W K	(V483320)	
-550	--	Wire Wound Resistor	0.22 5W K	(V483320)	
R551	--	Carbon Resistor (chip)	1.2K 1/16W J	(RD35612)	
R552	--	Carbon Resistor (chip)	1.2K 1/16W J	(RD35612)	
R553	--	Carbon Resistor (chip)	22 1/16W J	(RD35422)	
R554	--	Carbon Resistor (chip)	2.2K 1/16W J	(RD35622)	
R555	--	Carbon Resistor (chip)	2.2K 1/16W J	(RD35622)	
R556	--	Carbon Resistor (chip)	22 1/16W J	(RD35422)	
R557	--	Carbon Resistor (chip)	150 1/16W J	(RD35515)	
R558	--	Carbon Resistor (chip)	150 1/16W J	(RD35515)	
R559	--	Carbon Resistor (chip)	1.0 1/4W J	(RD15310)	
R560	--	Carbon Resistor (chip)	1.0 1/4W J	(RD15310)	
R561	--	Wire Wound Resistor	0.1 5W K	(VZ37020)	
R562	--	Wire Wound Resistor	0.1 5W K	(VZ37020)	
R563	--	Carbon Resistor (chip)	1.0 1/4W J	(RD15310)	
R564	--	Carbon Resistor (chip)	1.0 1/4W J	(RD15310)	
R565	--	Wire Wound Resistor	0.1 5W K	(VZ37020)	
R566	--	Wire Wound Resistor	0.1 5W K	(VZ37020)	
R567	--	Carbon Resistor (chip)	1.0 1/4W J	(RD15310)	
R568	--	Carbon Resistor (chip)	1.0 1/4W J	(RD15310)	
R569	--	Flame Proof C. Resistor	1.0 1/4W J	(HV75310)	
R570	--	Wire Wound Resistor	0.1 5W K	(VZ37020)	
R571	--	Wire Wound Resistor	0.1 5W K	(VZ37020)	
R572	--	Flame Proof C. Resistor	1.0 1/4W J	(HV75310)	
R573	--	Carbon Resistor (chip)	1.0 1/4W J	(RD15310)	
R574	--	Carbon Resistor (chip)	1.0 1/4W J	(RD15310)	
R575	--	Wire Wound Resistor	0.1 5W K	(VZ37020)	
R576	--	Wire Wound Resistor	0.1 5W K	(VZ37020)	
R577	--	Carbon Resistor (chip)	47K 1/4W J	(RD15747)	
R578	--	Carbon Resistor (chip)	47K 1/4W J	(RD15747)	
R579	--	Carbon Resistor (chip)	4.7 1/16W J	(RD35347)	
R580	--	Carbon Resistor (chip)	330 1/16W J	(RD35533)	
R581	--	Carbon Resistor (chip)	10K 1/4W J	(RD15710)	
R582	--	Carbon Resistor (chip)	1.0K 1/16W J	(RD35610)	
R583	--	Carbon Resistor (chip)	4.7 1/16W J	(RD35347)	
R584	--	Carbon Resistor (chip)	4.7 1/16W J	(RD35347)	
R585	--	Carbon Resistor (chip)	1.0K 1/16W J	(RD35610)	
R586	--	Carbon Resistor (chip)	330 1/16W J	(RD35533)	
R587	--	Carbon Resistor (chip)	1.0K 1/16W J	(RD35610)	
R588	--	Carbon Resistor (chip)	330 1/16W J	(RD35533)	
R589	--	Carbon Resistor (chip)	1.0K 1/16W J	(RD35610)	
R590	--	Carbon Resistor (chip)	330 1/16W J	(RD35533)	
R591	--	Carbon Resistor (chip)	330 1/16W J	(RD35533)	
R592	--	Carbon Resistor (chip)	470 1/4W J	(RD15547)	
R593	--	Carbon Resistor (chip)	470 1/4W J	(RD15547)	
R594	--	Carbon Resistor (chip)	100 1/16W J	(RD35510)	
R595	--	Carbon Resistor (chip)	4.7 1/16W J	(RD35347)	
R596	--	Carbon Resistor (chip)	100 1/16W J	(RD35510)	
R597	--	Carbon Resistor (chip)	4.7K 1/4W J	(RD15647)	
R598	--	Carbon Resistor (chip)	22 1/16W J	(RD35422)	
-603	--	Carbon Resistor (chip)	22 1/16W J	(RD35422)	
R604	--	Flame Proof C. Resistor	680 1/4W J	(HV75568)	
R605	--	Flame Proof C. Resistor	680 1/4W J	(HV75568)	

*: New Parts

RANK: Japan only

PAANL and PSANL

REF NO.	PART NO.	DESCRIPTION		REMARKS	QTY
R606	--	Carbon Resistor (chip)	4.7 1/16W J	(RD35347)	
R607	--	Carbon Resistor (chip)	100K 1/16W J	(RD35810)	
R608	--	Carbon Resistor (chip)	100K 1/16W J	(RD35810)	
R609	--	Thick Film Resistor (chip)	330 1/10W D	(RD55533)	
R610	--	Thick Film Resistor (chip)	330 1/10W D	(RD55533)	
R611	--	Carbon Resistor (chip)	2.2M 1/16W J	(RD35922)	
R612	--	Carbon Resistor (chip)	330K 1/16W J	(RD35833)	
RY401	--	Relay	DC G6J-2P-Y	(WJ53740)	
RY402	--	Relay	DC G6J-2P-Y	(WJ53740)	
VR401	--	Trimmer Potentiometer	B220 FUSE 3P EVN	(WK58070)	
VR402	--	Trimmer Potentiometer	B220 FUSE 3P EVN	(WK58070)	
VR403	--	Trimmer Potentiometer	B470 FUSE 3P EVN	(VL40330)	
VR404	--	Trimmer Potentiometer	B470 FUSE 3P EVN	(VL40330)	
W401	--	Connector Assembly PAPS	B&C TUBE 7P 280mm	(WK14210)	
W402	--	Connector Assembly	B&C 1P 200mm RE	(WM04870)	
W403	--	Connector Assembly	B&C 1P 200mm BK	(WK16800)	
W404	--	Connector Assembly	B&C 1P 200mm WH	(WK16810)	
W405	--	Connector Assembly	B&C 1P 250mm OR	(WN52530)	
W406	--	Connector Assembly	B&C 1P 300mm YE	(WK16830)	
* WJ974100		Circuit Board	PSANL	U (X8715D0)	
* WJ974200		Circuit Board	PSANL	CHN (X8715D0)	
--		Fuse Holder	PIN WL-211	U (WA77220)	4
--		Fuse Clip	CLIP EYF52BCY	U (WC05070)	2
--		Fuse Clip	CLIP EYF52BCY	CHN (WC05070)	6
C101	--	Capacitor	1.0uF 275V	(V936510)	
C102	--	Capacitor	1.0uF 275V	(V936510)	
C103	--	Electrolytic Cap.	2200pF 250V	(WK46370)	
C104	--	Electrolytic Cap.	2200pF 250V	(WK46370)	
C105	--	Capacitor	1.0uF 275V	(V936510)	
C106	--	Electrolytic Cap.	1000pF 250V	(WK46360)	
C107	--	Electrolytic Cap.	1000pF 250V	(WK46360)	
C201	--	Polyester Cap.	0.047uF 400V K	(WB68710)	
C202	--	Electrolytic Cap.	47uF 35V	(UR85747)	
C203	--	Electrolytic Cap.	22uF 25V	(WF20440)	
C204	--	Electrolytic Cap.	22uF 25V	(WF20440)	
C205	--	Electrolytic Cap.	100uF 400V	(WK76570)	
C206	--	Ceramic Capacitor-F (chip)	0.1uF 50V Z	(US06510)	
-208	--	Ceramic Capacitor-F (chip)	0.1uF 50V Z	(US06510)	
C209	--	Ceramic Capacitor-B	2200pF 1KV K	(WJ59710)	
C210	--	Electrolytic Cap.	47uF 35V	(UR85747)	
C211	--	Electrolytic Cap.	10uF 50V	(UR86710)	
C212	--	Electrolytic Cap.	10uF 50V	(UR86710)	
C213	--	Electrolytic Cap.	22uF 25V	(WF20440)	
C214	--	Electrolytic Cap.	22uF 25V	(WF20440)	
C215	--	Electrolytic Cap.	220uF 25V	(WF20450)	
C216	--	Electrolytic Cap.	10uF 100V	(VN70430)	
C217	--	Electrolytic Cap.	330uF 35V	(WJ86030)	
C218	--	Electrolytic Cap.	330uF 35V	(WJ86030)	
C219	--	Electrolytic Cap.	4700uF 6.3V	(WJ59720)	
C220	--	Electrolytic Cap.	47uF 35V	(UR85747)	
C221	--	Electrolytic Cap.	47uF 35V	(UR85747)	
C222	--	Electrolytic Cap.	4700uF 6.3V	(WJ59720)	
C223	--	Electrolytic Cap.	10uF 50V	(UR86710)	
C224	--	Ceramic Capacitor-F (chip)	0.1uF 50V Z	(US06510)	
C225	--	Ceramic Capacitor-F (chip)	0.1uF 50V Z	(US06510)	
C226	--	Ceramic Capacitor-B (chip)	1000pF 50V K	(US06310)	
C229	--	Ceramic Capacitor-F (chip)	0.1uF 50V Z	(US06510)	
-231	--	Ceramic Capacitor-F (chip)	0.1uF 50V Z	(US06510)	
C232	--	Electrolytic Cap.	47uF 35V	(UR85747)	
C233	--	Electrolytic Cap.	47uF 35V	(UR85747)	
C234	--	Electrolytic Cap.	100uF 16V	(UR83810)	
C235	--	Ceramic Capacitor-F (chip)	0.1uF 50V Z	(US06510)	
C236	--	Electrolytic Cap.	47uF 35V	(UR85747)	
C237	--	Electrolytic Cap.	47uF 35V	(UR85747)	
C238	--	Ceramic Capacitor-F (chip)	1.0uF 10V Z	(US12610)	
C239	--	Electrolytic Cap.	470uF 6.3V	(WB80680)	
C240	--	Electrolytic Cap.	220uF 6.3V	(UR81822)	
C241	--	Ceramic Capacitor-F (chip)	0.1uF 50V Z	(US06510)	
C242	--	Electrolytic Cap.	220uF 6.3V	(VN69150)	

*: New Parts

RANK: Japan only

PSANL

REF NO.	PART NO.	DESCRIPTION		REMARKS	QTY
C243	--	Ceramic Capacitor-F (chip)	0.1uF 50V Z	(US06510)	
C244	--	Ceramic Capacitor-F (chip)	0.1uF 50V Z	(US06510)	
C246	--	Ceramic Capacitor-F (chip)	0.1uF 50V Z	(US06510)	
C247	--	Ceramic Capacitor-F (chip)	0.1uF 50V Z	(US06510)	
C248	--	Electrolytic Cap.	10uF 50V	(UR86710)	
C249	--	Ceramic Capacitor-B(chip)	0.1uF 50V K	(WD96920)	
-254	--	Ceramic Capacitor-B(chip)	0.1uF 50V K	(WD96920)	
C255	--	Monolithic Ceramic Cap.	1000pF 250V K	(WJ83500)	
C257	--	Ceramic Capacitor-B(chip)	0.1uF 50V K	(WD96920)	
C258	--	Monolithic Ceramic Cap.	68pF 1000V J	(WK91490)	
C301	--	Ceramic Capacitor-SL(chip)	100pF 50V J	(US06210)	
C302	--	Ceramic Capacitor-SL(chip)	100pF 50V J	(US06210)	
C303	--	Monolithic Mylar Capacitor	0.1uF 50V	(VR16830)	
C304	--	Electrolytic Cap.	10uF 50V	(UR86710)	
C305	--	Ceramic Capacitor-SL(chip)	470pF 50V J	(US06247)	
C306	--	Electrolytic Cap.	10uF 50V	(UR86710)	
C307	--	Monolithic Mylar Capacitor	0.1uF 50V	(VR16830)	
C308	--	Monolithic Mylar Capacitor	0.1uF 50V	(VR16830)	
C310	--	Ceramic Capacitor-SL(chip)	470pF 50V J	(US06247)	
C311	--	Ceramic Capacitor-SL(chip)	470pF 50V J	(US06247)	
C312	--	Ceramic Capacitor-CH(chip)	22pF 50V J	(US06122)	
C313	--	Ceramic Capacitor-CH(chip)	22pF 50V J	(US06122)	
C314	--	Ceramic Capacitor-B (chip)	0.01uF 50V K	(US06410)	
C315	--	Ceramic Capacitor-B (chip)	0.01uF 50V K	(US06410)	
C316	--	Electrolytic Cap.	2200uF 200V	(WD53830)	
-319	--	Electrolytic Cap.	2200uF 200V	(WD53830)	
C320	--	Electrolytic Cap.	10uF 50V	(UR86710)	
C321	--	Electrolytic Cap.	10uF 50V	(UR86710)	
C322	--	Electrolytic Cap.	2200uF 200V	(WD53830)	
-325	--	Electrolytic Cap.	2200uF 200V	(WD53830)	
C326	--	Polypropylene Capacitor	1.8uF 250V J	(WH34340)	
-329	--	Polypropylene Capacitor	1.8uF 250V J	(WH34340)	
C330	--	Monolithic Mylar Capacitor	0.1uF 50V	(VR16830)	
C331	--	Ceramic Capacitor-B (chip)	0.01uF 50V K	(US06410)	
C332	--	Monolithic Mylar Capacitor	0.1uF 50V	(VR16830)	
C333	--	Ceramic Capacitor-B (chip)	0.01uF 50V K	(US06410)	
C334	--	Electrolytic Cap.	10uF 25V	(WD53850)	
C335	--	Electrolytic Cap.	10uF 50V	(UR86710)	
C336	--	Electrolytic Cap.	10uF 25V	(WD53850)	
C337	--	Electrolytic Cap.	10uF 50V	(UR86710)	
C338	--	Ceramic Capacitor-CH(chip)	22pF 50V J	(US06122)	
C339	--	Ceramic Capacitor-CH(chip)	22pF 50V J	(US06122)	
C340	--	Electrolytic Cap.	10uF 25V	(WD53850)	
-343	--	Electrolytic Cap.	10uF 25V	(WD53850)	
C344	--	Electrolytic Cap.	1200uF 160V	(WJ99780)	
C345	--	Electrolytic Cap.	1200uF 160V	(WJ99780)	
C346	--	Electrolytic Cap.	100uF 35V	(V902330)	
C347	--	Electrolytic Cap.	1200uF 160V	(WJ99780)	
C348	--	Electrolytic Cap.	1200uF 160V	(WJ99780)	
C349	--	Electrolytic Cap.	100uF 35V	(V902330)	
C350	--	Monolithic Mylar Capacitor	0.1uF 50V	(VR16830)	
C351	--	Monolithic Mylar Capacitor	0.1uF 50V	(VR16830)	
C352	--	Ceramic Capacitor-B(chip)	0.1pF 50V K	(WD96920)	
C353	--	Ceramic Capacitor-B(chip)	0.1pF 50V K	(WD96920)	
C354	--	Electrolytic Cap.	1200uF 160V	(WJ99780)	
-357	--	Electrolytic Cap.	1200uF 160V	(WJ99780)	
C358	--	Ceramic Capacitor-F (chip)	0.1uF 50V Z	(US06510)	
C359	--	Ceramic Capacitor-F (chip)	0.1uF 50V Z	(US06510)	
C360	--	Electrolytic Cap.	4.7uF 50V	(UR86647)	
C361	--	Electrolytic Cap.	4.7uF 50V	(UR86647)	
C362	--	Ceramic Capacitor-B (chip)	0.01uF 50V K	(US06410)	
C363	--	Ceramic Capacitor-B (chip)	0.01uF 50V K	(US06410)	
C364	--	Ceramic Capacitor-B (chip)	1000pF 50V K	(US06310)	
C365	--	Ceramic Capacitor-B(chip)	0.1uF 50V K	(WD96920)	
C366	--	Ceramic Capacitor-B(chip)	0.1uF 50V K	(WD96920)	
CN101	--	Screw Terminal	P-820N	(WK66210)	
CN102	--	Screw Terminal	P-820N	(WK66210)	
CN103	--	Base Post Connector	VH 3P TE	(LB93203)	
CN201	--	Connector Base Post	PH 9P TE	(VB39050)	
CN202	--	Connector Base Post	PH 5P TE	(VB39010)	

*: New Parts

RANK: Japan only

PSANL

REF NO.	PART NO.	DESCRIPTION		REMARKS	QTY
CN305	--	Fasten Terminal	16611BL-2	(WA76770)	
-310	--	Fasten Terminal	16611BL-2	(WA76770)	
CN311	--	Connector Base Post	PH 2P TE	(VB38980)	
CN312	--	Connector Base Post	PH 7P TE	(VB39030)	
CN313	--	Connector Base Post	PH 11P TE	(VB39070)	
CN314	--	Connector Base Post	PH 2P TE	(VB38980)	
CN315	--	Connector Base Post	PH 7P TE	(VB39030)	
CN316	--	Fasten Terminal	16611BL-2	(WA76770)	
CN317	--	Fasten Terminal	16611BL-2	(WA76770)	
D101	--	Diode	1SS355 TE-17	(VT33290)	
D102	--	Diode	1SS355 TE-17	(VT33290)	
D201	--	Diode	1SR154-400	(VT53250)	
D202	--	Diode	D2F60-5063	(WK83640)	
-205	--	Diode	D2F60-5063	(WK83640)	
D206	--	Zener Diode	120V 1SMB5951BT3G	(WK91200)	
D207	--	Zener Diode	150V 1SMB5953BT3G	(WK91190)	
D208	--	Diode	AG01A WS	(V862980)	
D209	--	Diode	1SS244 TP	(WA18030)	
D210	--	Diode (chip)	1.1A 200V D1FL20U	(VV46300)	
D211	--	Diode (chip)	1.1A 200V D1FL20U	(VV46300)	
D212	--	Diode	1SS244 TP	(WA18030)	
D214	--	Diode (chip)	SJPX-H3 VR	(WK83420)	
D215	--	Diode (chip)	1.1A 200V D1FL20U	(VV46300)	
D216	--	Zener Diode	3.6V UDZS3.6B	(VU17150)	
D218	--	Diode (chip)	RB160L-40 TE25	(VS59760)	
D219	--	Diode (chip)	RB160L-40 TE25	(VS59760)	
D220	--	Diode	DE3S6M	(WE49220)	
D221	--	Diode (chip)	RB160L-40 TE25	(VS59760)	
-224	--	Diode (chip)	RB160L-40 TE25	(VS59760)	
D226	--	Diode (chip)	RB160L-40 TE25	(VS59760)	
D227	--	Diode	1SS244 TP	(WA18030)	
D301	--	Diode	1SS244 TP	(WA18030)	
D302	--	Diode	1SS244 TP	(WA18030)	
D303	--	Zener Diode	UDZS12B TE-17 12V	(VU17280)	
D304	--	Zener Diode	UDZS12B TE-17 12V	(VU17280)	
D307	--	Diode	AG01A WS	(V862980)	
D308	--	Diode	AG01A WS	(V862980)	
D309	--	Diode (chip)	1.1A 200V D1FL20U	(VV46300)	
-312	--	Diode (chip)	1.1A 200V D1FL20U	(VV46300)	
D313	--	Diode	RL3A	(V862970)	
-316	--	Diode	RL3A	(V862970)	
D317	--	Diode (chip)	1.1A 200V D1FL20U	(VV46300)	
D318	--	Diode (chip)	1.1A 200V D1FL20U	(VV46300)	
D323	--	Diode (chip)	1.1A 200V D1FL20U	(VV46300)	
-328	--	Diode (chip)	1.1A 200V D1FL20U	(VV46300)	
D329	--	Zener Diode	UDZS16B TE-17 16V	(VU17310)	
D330	--	Zener Diode	UDZS12B TE-17 12V	(VU17280)	
D331	--	Zener Diode	UDZS16B TE-17 16V	(VU17310)	
D332	--	Zener Diode	UDZS12B TE-17 12V	(VU17280)	
D333	--	Schottky Diode	RB551V-30	(V963430)	
D334	--	Schottky Diode	RB551V-30	(V963430)	
F101	--	Fuse	TH 3.15A S	(VT94300)	
F301	--	Fuse	25A 250V JU	(V893200)	U
F301	--	Fuse	TH 10A 250V	(V541370)	CHN
F302	--	Fuse	25A 250V JU	(V893200)	U
F302	--	Fuse	TH 10A 250V	(V541370)	CHN
F303	--	Fuse	5.0A UC	(WE90920)	
F304	--	Fuse	5.0A UC	(WE90920)	
H101	--	Heat Sink Unit	AN-PA-HIGH 100mm	(WK66920)	
H102	--	Heat Sink Unit	AN-PA-HIGH 60mm	(WK66930)	
H103	--	Heat Sink Unit	AN-PA-HIGH 50mm	(WK66950)	
H104	--	Heat Sink Unit	AN-PA-HIGH 100mm	(WK66910)	
H105	--	Heat Sink Unit	AN-PA-HIGH 60mm	(WK66940)	
H106	--	Heat Sink Unit	NX,TX6 25mm	(WM44760)	
IC202	--	IC	NJM7815FA	REGULATOR +15V (XD853A0)	
IC203	--	IC	NJM7815FA	REGULATOR +15V (XD853A0)	
IC204	--	IC	NJM431U(Te1)	SHUNT REGULATOR (X6770A0)	
IC205	--	IC	NJU7630M(Te1) PWM	SW REGULATOR (X8682A0)	
IC208	--	IC	PQ1CX12H2ZPQ	REGULATOR (X6188A0)	

△
△
△

△
△
△
△
△
△
△

*: New Parts

RANK: Japan only

PSANL

REF NO.	PART NO.	DESCRIPTION		REMARKS	QTY
IC301	--	IC	SG2525AN PWM IC	PW MODULATOR (X8960A0)	
IC302	X2382A02	IC	IR2110	DRIVER	
IC303	X2382A02	IC	IR2110	DRIVER	
J301	--	Wire Harness	0.55 TIN	U (VA07891)	
-304	--	Wire Harness	0.55 TIN	U (VA07891)	
J305	--	Wire Harness	0.55 TIN	CHN (VA07891)	
J306	--	Wire Harness	0.55 TIN	CHN (VA07891)	
J307	--	Wire Harness	0.55 TIN	U (VA07891)	
-310	--	Wire Harness	0.55 TIN	U (VA07891)	
J311	--	Wire Harness	0.55 TIN	CHN (VA07891)	
J312	--	Wire Harness	0.55 TIN	CHN (VA07891)	
K101	--	GND Plate	MLA8	(WC53340)	
L101	--	Coil	LDFM025252MJ-H0E Y	(WH26940)	
L102	--	Coil	LDFM025252MJ-H0E Y	(WH26940)	
L201	--	Chip Inductance	6.8uH	(WK03780)	
-204	--	Chip Inductance	6.8uH	(WK03780)	
L205	--	Coil	10uH LH L 08TB100	(VR92920)	
L206	--	Chip Inductance	10uH 7313NA100M	(WD95290)	
L207	--	Coil	220uH	(WK11970)	
L208	--	Chip Inductance	6.8uH	(WK03780)	
-210	--	Chip Inductance	6.8uH	(WK03780)	
L301	--	Chip Inductance	6.8uH	(WK03780)	
L302	--	Chip Inductance	6.8uH	(WK03780)	
PH201	--	Photo Coupler	TLP421 GR	(V810050)	
PH202	--	Photo Coupler	TLP421 GR	(V810050)	
PH301	--	Photo Coupler	TLP421 GR	(V810050)	
-303	--	Photo Coupler	TLP421 GR	(V810050)	
Q201	--	Transistor	2SC2412K Q,R,S	(VV55640)	
Q202	--	Digital Transistor	KRC102S-RTK/P	(WC43500)	
Q203	--	Digital Transistor	KRC102S-RTK/P	(WC43500)	
Q204	--	Transistor	2SC2412K Q,R,S	(VV55640)	
Q206	--	Transistor	2SC2412K Q,R,S	(VV55640)	
Q207	--	Transistor	2SC2412K Q,R,S	(VV55640)	
Q214	--	FET	TPC8109(TE12L,Q)	(WD54130)	
Q217	--	Transistor	2SC2412K Q,R,S	(VV55640)	
Q218	--	Transistor	2SA1037AK Q,R,S	(VV55650)	
Q219	--	Transistor	2SC2412K Q,R,S	(VV55640)	
Q301	--	Digital Transistor	KRC102S-RTK/P	(WC43500)	
Q302	--	Transistor	2SC2412K Q,R,S	(VV55640)	
Q303	--	Transistor	2SC2412K Q,R,S	(VV55640)	
Q304	--	Transistor	2SA1037AK Q,R,S	(VV55650)	
Q305	--	Transistor	2SA1037AK Q,R,S	(VV55650)	
Q306	--	Digital Transistor	KRC102S-RTK/P	(WC43500)	
Q307	--	Digital Transistor	KRC102S-RTK/P	(WC43500)	
Q308	--	Transistor	2SA1037AK Q,R,S	(VV55650)	
Q309	--	Transistor	2SA1037AK Q,R,S	(VV55650)	
Q310	--	Digital Transistor	KRA102S-RTK/P	(WC43480)	
Q311	--	Digital Transistor	KRA102S-RTK/P	(WC43480)	
Q312	--	Digital Transistor	KRC102S-RTK/P	(WC43500)	
Q313	--	Digital Transistor	KRC102S-RTK/P	(WC43500)	
Q318	--	Digital Transistor	KRC102S-RTK/P	(WC43500)	
Q319	--	Digital Transistor	KRC102S-RTK/P	(WC43500)	
Q320	--	Transistor	2SC2412K Q,R,S	(VV55640)	
-323	--	Transistor	2SC2412K Q,R,S	(VV55640)	
Q326	--	Digital Transistor	KRC102S-RTK/P	(WC43500)	
-329	--	Digital Transistor	KRC102S-RTK/P	(WC43500)	
Q330	--	Transistor	2SC2412K Q,R,S	(VV55640)	
-332	--	Transistor	2SC2412K Q,R,S	(VV55640)	
R101	--	Carbon Resistor	220K 1/4W J	(HF05822)	
R102	--	Carbon Resistor	220K 1/4W J	(HF05822)	
R103	VN067401	Wire Wound Resistor	6.8 5W K		
-105	VN067401	Wire Wound Resistor	6.8 5W K		
R106	--	Carbon Resistor	220K 1/4W J	CHN (HF05822)	
R107	--	Carbon Resistor	220K 1/4W J	CHN (HF05822)	
R108	VN067401	Wire Wound Resistor	6.8 5W K	CHN	
R111	--	Carbon Resistor (chip)	470 1/16W J	(RD35547)	
-113	--	Carbon Resistor (chip)	470 1/16W J	(RD35547)	
R114	--	Carbon Resistor (chip)	4.7K 1/16W J	(RD35647)	
R115	--	Carbon Resistor (chip)	2.2K 1/16W J	(RD35622)	
R116	--	Carbon Resistor (chip)	22 1/16W J	(RD35422)	

*: New Parts

RANK: Japan only

PSANL

REF NO.	PART NO.	DESCRIPTION		REMARKS	QTY
-119	--	Carbon Resistor (chip)	22 1/16W J	(RD35422)	
R122	--	Carbon Resistor (chip)	10 1/16W J	(RD35410)	
R123	--	Carbon Resistor (chip)	10 1/16W J	(RD35410)	
R124	--	Carbon Resistor (chip)	560K 1/10W D	(V646540)	
R125	--	Carbon Resistor (chip)	560K 1/10W D	(V646540)	
R201	--	Metal Oxide Film Resistor	100K 2W J	(WK03770)	
R202	--	Metal Oxide Film Resistor	100K 2W J	(WK03770)	
R203	--	Carbon Resistor (chip)	3.9K 1/16W J	(RD35639)	
R204	--	Carbon Resistor (chip)	3.9K 1/16W J	(RD35639)	
R205	--	Carbon Resistor (chip)	10K 1/16W J	(RD35710)	
R206	--	Carbon Resistor (chip)	15K 1/16W J	(RD35715)	
R207	--	Carbon Resistor (chip)	120K 1/16W J	(RD35812)	
R208	--	Carbon Resistor (chip)	10K 1/16W J	(RD35710)	
R209	--	Carbon Resistor	1.0M 1/4W J	(HF45910)	
R210	--	Carbon Resistor	1.0M 1/4W J	(HF45910)	
R211	--	Carbon Resistor (chip)	10K 1/16W J	(RD35710)	
R212	--	Carbon Resistor (chip)	10K 1/16W J	(RD35710)	
R213	--	Metal Oxide Film Resistor	33K 2W J	(VT87980)	
-216	--	Metal Oxide Film Resistor	33K 2W J	(VT87980)	
R217	--	Carbon Resistor (chip)	1.0 1/16W J	(RD35310)	
-224	--	Carbon Resistor (chip)	1.0 1/16W J	(RD35310)	
R225	--	Carbon Resistor (chip)	150 1/16W J	(RD35515)	
R226	--	Carbon Resistor (chip)	47K 1/16W J	(RD35747)	
R227	--	Carbon Resistor (chip)	100K 1/16W J	(RD35810)	
R228	--	Carbon Resistor (chip)	220K 1/16W J	(RD35822)	
R229	--	Carbon Resistor (chip)	220K 1/16W J	(RD35822)	
R230	--	Carbon Resistor (chip)	1.5K 1/16W J	(RD35615)	
R231	--	Carbon Resistor (chip)	220K 1/16W D	(RF45822)	
R232	--	Carbon Resistor (chip)	8.2K 1/16W D	(RF45682)	
R237	--	Carbon Resistor (chip)	3.3K 1/16W J	(RD35633)	
R240	--	Carbon Resistor (chip)	10K 1/16W D	(RF45710)	
R241	--	Carbon Resistor (chip)	10K 1/16W D	(RF45710)	
R244	--	Carbon Resistor (chip)	10K 1/16W J	(RD35710)	
R245	--	Carbon Resistor (chip)	4.7 1/16W J	(RD35347)	
R246	--	Carbon Resistor (chip)	15K 1/16W J	(RD35715)	
R249	--	Carbon Resistor (chip)	150K 1/16W J	(RD35815)	
R250	--	Carbon Resistor (chip)	100K 1/16W J	(RD35810)	
R253	--	Carbon Resistor (chip)	3.3K 1/16W D	(RF45633)	
R254	--	Carbon Resistor (chip)	150 1/16W D	(RF45515)	
R255	--	Carbon Resistor (chip)	1.5K 1/16W D	(RF45615)	
R256	--	Carbon Resistor (chip)	10K 1/16W J	(RD35710)	
R257	--	Carbon Resistor (chip)	47K 1/16W J	(RD35747)	
R258	--	Carbon Resistor (chip)	47K 1/16W J	(RD35747)	
R259	--	Carbon Resistor (chip)	4.7K 1/16W D	(RF45647)	
R260	--	Carbon Resistor (chip)	680 1/16W D	(RF45568)	
R261	--	Carbon Resistor (chip)	1.8K 1/16W D	(RF45618)	
R262	--	Carbon Resistor (chip)	680 1/16W J	(RD35568)	
R263	--	Carbon Resistor (chip)	1.5K 1/16W J	(RD35615)	
R264	--	Carbon Resistor (chip)	10K 1/16W J	(RD35710)	
R265	--	Carbon Resistor (chip)	680 1/16W J	(RD35568)	
R267	--	Carbon Resistor (chip)	0 1/16W J	(RD35000)	
-270	--	Carbon Resistor (chip)	0 1/16W J	(RD35000)	
R273	--	Carbon Resistor (chip)	4.7 1/16W J	(RD35347)	
R277	--	Carbon Resistor (chip)	47 1/2W J	(V263940)	
R301	--	Carbon Resistor (chip)	5.1K 1/16W J	(RD35651)	
-303	--	Carbon Resistor (chip)	5.1K 1/16W J	(RD35651)	
R304	--	Carbon Resistor (chip)	100 1/16W J	(RD35510)	
R305	--	Carbon Resistor (chip)	100 1/16W J	(RD35510)	
R306	--	Carbon Resistor (chip)	5.1K 1/16W J	(RD35651)	
-308	--	Carbon Resistor (chip)	5.1K 1/16W J	(RD35651)	
R309	--	Carbon Resistor (chip)	10K 1/16W J	(RD35710)	
R310	--	Carbon Resistor (chip)	18K 1/16W D	(RF45718)	
R311	--	Carbon Resistor (chip)	330 1/16W J	(RD35533)	
R312	--	Carbon Resistor (chip)	22 1/16W J	(RD35422)	
R313	--	Carbon Resistor (chip)	3.3K 1/16W J	(RD35633)	
-316	--	Carbon Resistor (chip)	3.3K 1/16W J	(RD35633)	
R317	--	Carbon Resistor (chip)	1.0K 1/16W J	(RD35610)	
R318	--	Carbon Resistor (chip)	1.0K 1/16W J	(RD35610)	
R319	--	Carbon Resistor (chip)	12K 1/16W J	(RD35712)	
R320	--	Carbon Resistor (chip)	12K 1/16W J	(RD35712)	

*: New Parts

RANK: Japan only

PSANL

REF NO.	PART NO.	DESCRIPTION		REMARKS	QTY
R321	--	Carbon Resistor (chip)	100K 1/16W J	(RD35810)	
R322	--	Carbon Resistor (chip)	100K 1/16W J	(RD35810)	
R323	--	Carbon Resistor (chip)	3.3K 1/16W J	(RD35633)	
R324	--	Carbon Resistor (chip)	3.3K 1/16W J	(RD35633)	
R325	--	Carbon Resistor (chip)	22K 1/16W J	(RD35722)	
R326	--	Carbon Resistor (chip)	22K 1/16W J	(RD35722)	
R327	--	Carbon Resistor (chip)	10K 1/16W J	(RD35710)	
-330	--	Carbon Resistor (chip)	10K 1/16W J	(RD35710)	
R331	--	Carbon Resistor (chip)	22K 1/16W J	(RD35722)	
-334	--	Carbon Resistor (chip)	22K 1/16W J	(RD35722)	
R335	--	Carbon Resistor (chip)	10K 1/16W J	(RD35710)	
-338	--	Carbon Resistor (chip)	10K 1/16W J	(RD35710)	
R339	--	Carbon Resistor (chip)	4.7K 1/16W J	(RD35647)	
R340	--	Carbon Resistor (chip)	22K 1/16W J	(RD35722)	
R341	--	Carbon Resistor (chip)	4.7K 1/16W J	(RD35647)	
R342	--	Carbon Resistor (chip)	22K 1/16W J	(RD35722)	
R343	--	Metal Oxide Film Resistor	100K 2W J	(WK03770)	
-346	--	Metal Oxide Film Resistor	100K 2W J	(WK03770)	
R347	--	Carbon Resistor (chip)	10 1/16W J	(RD35410)	
R348	--	Carbon Resistor (chip)	10 1/16W J	(RD35410)	
R349	--	Carbon Resistor (chip)	22 1/16W J	(RD35422)	
-352	--	Carbon Resistor (chip)	22 1/16W J	(RD35422)	
R353	--	Carbon Resistor (chip)	1.2K 1/16W J	(RD35612)	
R354	--	Carbon Resistor (chip)	1.2K 1/16W J	(RD35612)	
R355	--	Carbon Resistor (chip)	4.7K 1/16W J	(RD35647)	
R356	--	Carbon Resistor (chip)	4.7K 1/16W J	(RD35647)	
R357	--	Wire Wound Resistor	0.1 5W K	(VZ37020)	
-364	--	Wire Wound Resistor	0.1 5W K	(VZ37020)	
R365	--	Carbon Resistor (chip)	1.0 1/16W J	(RD35310)	
R366	--	Carbon Resistor (chip)	1.0 1/16W J	(RD35310)	
R367	--	Metal Oxide Film Resistor	27 2W J	(WK58150)	
R368	--	Carbon Resistor (chip)	1.0 1/16W J	(RD35310)	
R369	--	Carbon Resistor (chip)	1.0 1/16W J	(RD35310)	
R370	--	Carbon Resistor (chip)	10K 1/16W J	(RD35710)	
R371	--	Carbon Resistor (chip)	10K 1/16W J	(RD35710)	
R372	--	Carbon Resistor	470K 1/4W J	(HF45847)	
-379	--	Carbon Resistor	470K 1/4W J	(HF45847)	
R382	--	Carbon Resistor (chip)	10K 1/16W J	(RD35710)	
R383	--	Carbon Resistor (chip)	10K 1/16W J	(RD35710)	
R384	--	Carbon Resistor (chip)	27K 1/16W J	(RD35727)	
R385	--	Carbon Resistor (chip)	27K 1/16W J	(RD35727)	
R386	--	Carbon Resistor (chip)	220K 1/16W J	(RD35822)	
R387	--	Carbon Resistor (chip)	18K 1/16W J	(RD35718)	
R388	--	Carbon Resistor (chip)	47K 1/16W J	(RD35747)	
R389	--	Carbon Resistor (chip)	220K 1/16W J	(RD35822)	
R390	--	Carbon Resistor (chip)	18K 1/16W J	(RD35718)	
R391	--	Carbon Resistor (chip)	47K 1/16W J	(RD35747)	
R392	--	Carbon Resistor (chip)	15K 1/16W J	(RD35715)	
R393	--	Carbon Resistor (chip)	15K 1/16W J	(RD35715)	
R394	--	Carbon Resistor (chip)	560K 1/10W D	(V646540)	
R395	--	Carbon Resistor (chip)	560K 1/10W D	(V646540)	
R396	--	Carbon Resistor (chip)	22K 1/16W D	(RF45722)	
R397	--	Carbon Resistor (chip)	22K 1/16W D	(RF45722)	
R398	--	Carbon Resistor (chip)	27K 1/16W J	(RD35727)	
R399	--	Carbon Resistor (chip)	27K 1/16W J	(RD35727)	
RY101	--	Relay	DC DI24D1-O(M)	(WJ56900)	
RY102	--	Relay	DC DI24D1-O(M)	(WJ56900)	
RY103	--	Relay	DC ALK3223	(WJ58430)	
T201	--	Power Transformer	UL CSA CE DENAN A	(X8693A0)	
T301	--	Transformer	TTEI16-01	(X2583A0)	
T302	--	Power Transformer	UL CE A	(X8549A0)	
T303	--	Power Transformer	UL CE A	(X8549A0)	
TH101	--	Thermistor	20ohm 20D2-11LT3C	(WK83630)	
W101	--	Connector Assembly PS	B&B	(WK17900)	
W102	--	Connector Assembly PS	B&B	(WK17910)	
	V8746701	DC Fan	FBA08A24H1TZ		
	WK602800	Power Cord Assembly	UL18A	U	
	WC901300	AC Cord	CHN 3 2.5m	CHN	

*: New Parts

RANK: Japan only

POWERED TD CONTROLLER

NXAMP4x1

CIRCUIT DIAGRAM

■ CONTENTS

IC & DIODE FIGURES	2
WIRING DIAGRAM	3
BLOCK DIAGRAM 1/5	4
2/5	5
3/5	6
4/5	7
5/5	8
OVERALL CIRCUIT DIAGRAM	
CONTROL 1/6	9
2/6	10
3/6	11
4/6	12
5/6	13
6/6	14
INANL	15
OUTANL	16
OPT-AN	17
PN-AN	18
RS232-GPI	19
PAANL	20
PSANL 1/3	21
2/3	22
3/3	23

■ WARNING

Components having special characteristics are marked  and must be replaced with parts having specification equal to those originally installed.

IC & DIODE FIGURES

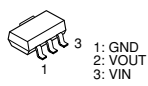
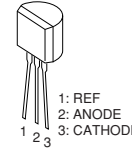
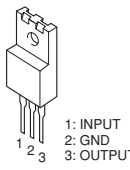
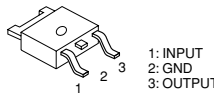
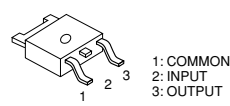
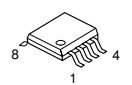
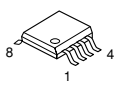
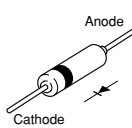
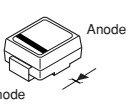
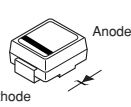
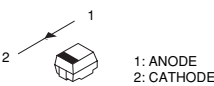
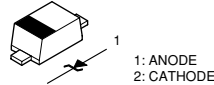
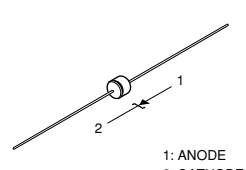
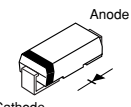
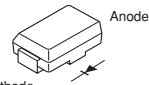
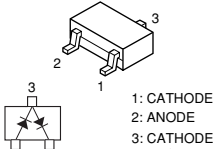
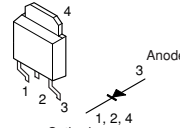
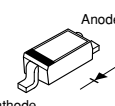
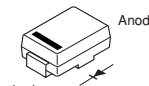
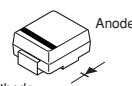
<ul style="list-style-type: none"> • LD1117STR (X8495A0) REGULATOR CONTROL: IC024 	<ul style="list-style-type: none"> • NJM431U (X6770A0) REGULATOR PSANL: IC204 	<ul style="list-style-type: none"> • NJM7815FA (XD853A0) REGULATOR +15V PSANL: IC202, 203 	<ul style="list-style-type: none"> • NJM78M09DL1A (XZ940A0) REGULATOR +15V CONTROL: IC006 
<ul style="list-style-type: none"> • NJM79M09DL1A (X5366A0) REGULATOR -9V CONTROL: IC007 	<ul style="list-style-type: none"> • NJU7630-M (X8682A0) REGULATOR -9V PSANL: IC205 	<ul style="list-style-type: none"> • PQ1CX12H2ZP (X6188A0) REGULATOR -9V PSANL: IC208 	
<ul style="list-style-type: none"> • 1SS244 (WA18030) DIODE PSANL: D209, 212, 227, 301, D302 	<ul style="list-style-type: none"> • 1SMB5951BT3G (WK91200) ZENER DIODE 120V PSANL: D206 	<ul style="list-style-type: none"> • 1SMB5953BT3G (WK91190) ZENER DIODE 150V PSANL: D207 	<ul style="list-style-type: none"> • 1SR154-400 (VT53250) DIODE PSANL: D201 • D1F60 (VS20110) DIODE PAANL: D443-448 
<ul style="list-style-type: none"> • 1SS355 (VT33290) DIODE INANL: D701-708 OUTANL: D801-804 PAANL: D401-404, 406, 407, D409-414, 439-442, D450-453 PSANL: D101, 102 • UDZS 3.6B (VU17150) ZENER DIODE 3.6V PSANL: D216 	<ul style="list-style-type: none"> • UDZS 3.9B (VU17160) ZENER DIODE 3.9V PAANL: D405, 408, 415, D420, 421, 426 • UDZS 5.6B (VU17200) ZENER DIODE 5.6V PAANL: D456 • UDZS6.8B (VU17220) ZENER DIODE 6.8V PAANL: D416, 419, 422, 425 	<ul style="list-style-type: none"> • UDZS12B (VU17280) ZENER DIODE 12V PSANL: D303, 304, 330, 332 • UDZS15B (VU17300) ZENER DIODE 15V PAANL: D449, 454, 455 • UDZS16B (VU17310) ZENER DIODE 16V PSANL: D329, 331 	<ul style="list-style-type: none"> • RB551V-30 (V963430) SCHOTTKY DIODE PSANL: D333, 334 
<ul style="list-style-type: none"> • AG01A WS (V862980) DIODE PAANL: D457 PSANL: D208, 307, 308 • RL3A (V862970) DIODE PSANL: D313-316 	<ul style="list-style-type: none"> • D1FK60-5063 (WJ45930) DIODE PAANL: D427-430 • D1FL20U-5063 (VV46300) DIODE PSANL: D210, 211, 215, 309-312, D317, 318, 323-328 	<ul style="list-style-type: none"> • RB160L-40 TE25 (VS59760) DIODE CONTROL: D001-004 PSANL: D218, 219, 221-224, D226 	
<ul style="list-style-type: none"> • D2F60-5063 (WK83640) DIODE PSANL: D202-205 	<ul style="list-style-type: none"> • DAN217 (VV55630) DIODE ARRAY 0.3AX2 CONTROL: DA001-036 	<ul style="list-style-type: none"> • DE3S6M (WE49220) DIODE PSANL: D220 	<ul style="list-style-type: none"> • HSU83 ((WD84430) DIODE PAANL: D417, 418, 423, 424, D431-438 
<ul style="list-style-type: none"> • SJPX-H3 VR (WK83420) DIODE PSANL: D214 	<ul style="list-style-type: none"> • SMP100LC-25 (WJ52830) DIODE CONTROL: D005, 006 		

■ WIRING DIAGRAM

Note:

B: Board in connector
F: Fasten terminal
S: Screw terminal

No.	Part No.	Destination
L1	WK02070	-
L2	WK66050	U
L3	WK66040	CHN
L4	WK94710	-
L5	WK68760	-
L6	WK68770	-
L7	WK14210	-
L8	WMO4870	-
L9	WK16800	-
L10	WK16810	-
L11	WK16820	-
L12	WK14210	-
L13	WMO4870	-
L14	WK16800	-
L15	WK16810	-
L16	WK16820	-
L30	WK02080	-
L31	WK90770	-
L32	WK90790	-
L33	WK17110	-
L34	WK02090	-
L36	WN52530	-
L38	WK16830	-
L40	WN52530	-
L42	WK16830	-
L43	WK02100	-
L44	WK02110	-
L45	WK02120	-

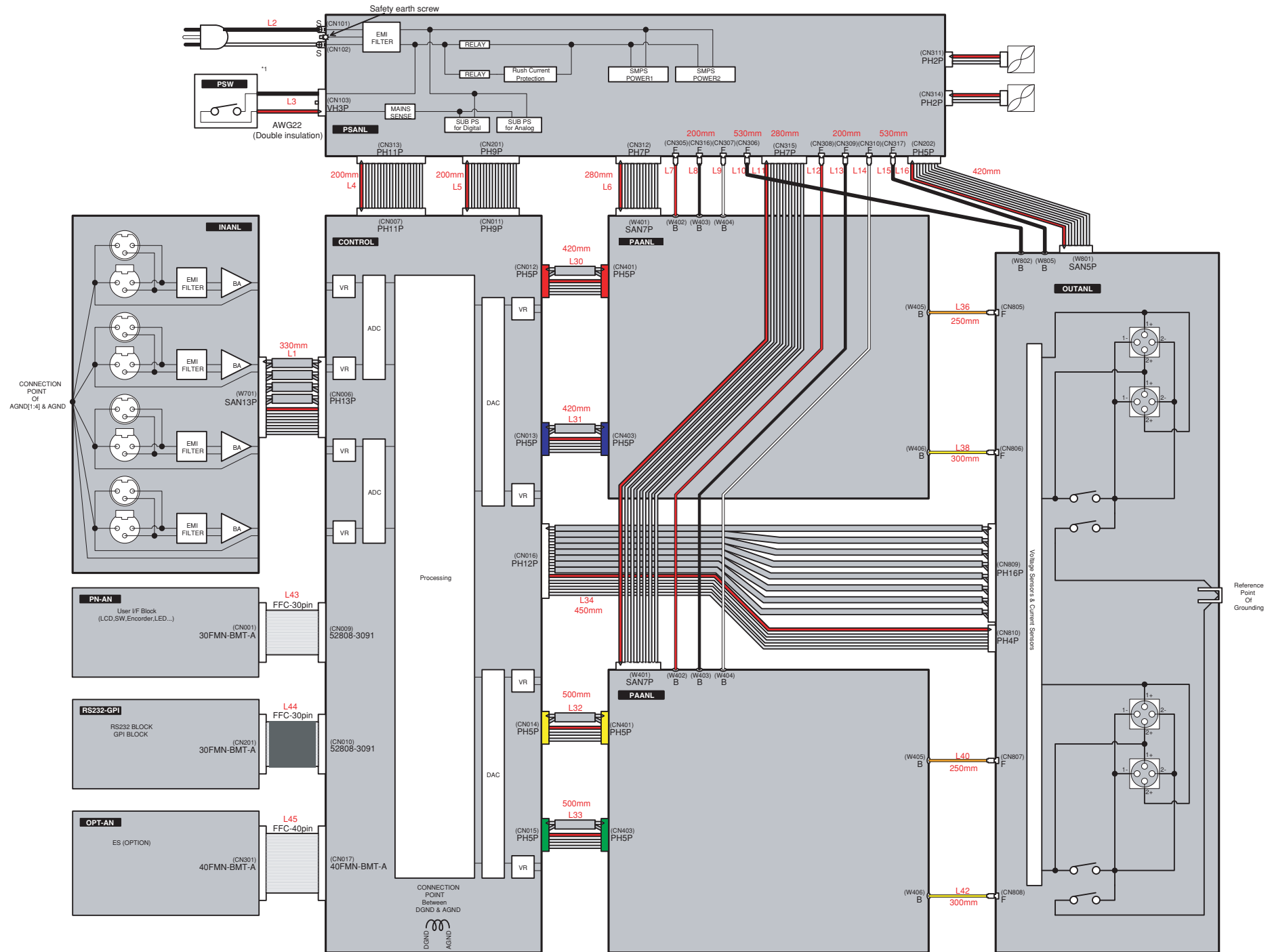

■ BLOCK DIAGRAM 1/5

Inter-Block Signals

INANH -> CONTROL	
ANA_IN[1:4]	Analog Audio Signals
PAANL -> CONTROL	
TEMP_PA[1:4]	Temperature Data of Power Amplifier Units
CLIP_PA[1:4]	Clip Signals of Power Amplifier Units
OUTANL -> CONTROL	
SENSE_U[1:4]	SenseBack Signals of Amplifier Output Voltage
SENSE_I[1:4]	SenseBack Signals of Amplifier Output Current
PSANL -> COLNTR	
MAINS_A	MAINS Data
PSW_DETECT	Status of Power Switch
TEMP_PS_A[1:2]	Temperature Signals of Power Supply Units
VOLTAGE_PS_A[1:2]	Output Voltage data of Power Supply Units
CONTROL -> PAANL	
ANA-OUT[1:4]	Analog Audio Signals
RELAY_PA1[1:4]	Control Signals for Relays on Power Amplifier Units
CONTROL -> OUTANL	
RELAY_OUT[1:4]	Control Signals for Output Relays
CONTROL -> PSANL	
RELAY_PS_A[1:2]	Control Signals for Relays on Power Supply Unit
SHUTDOWN_PS_A	Shutdown Signals for Power Supply Circuits
FAN_CONTROL_[1:2]	FAN speed control signals
PAANL -> OUTPAL	
POUT[1:4]	Output of Power Amplifier Units

Power Supply Lines

+24A_A +24A_B +15A +9A +5A -9A -15A	for Small Signal Analog Circuits
+5D +3.3D	for Digital Circuits
+B_A[1:2] -B_A[1:2]	Positive Rail Voltage Line for Power Amplifier Units Negative Rail Voltage Line for Power Amplifier Units
+E_A[1:2]+15 +E_A[1:2] -E_A[1:2]+15 -E_A[1:2]	For EEEngine Drive

GND Lines

AGND[1:4]	for Analog Audio Signals of Each Channel
AGND	for Common Analog Circuits
DGND	for Digital Circuits
PGND_A[1:2]	Reference Voltage of Main Power Supplies

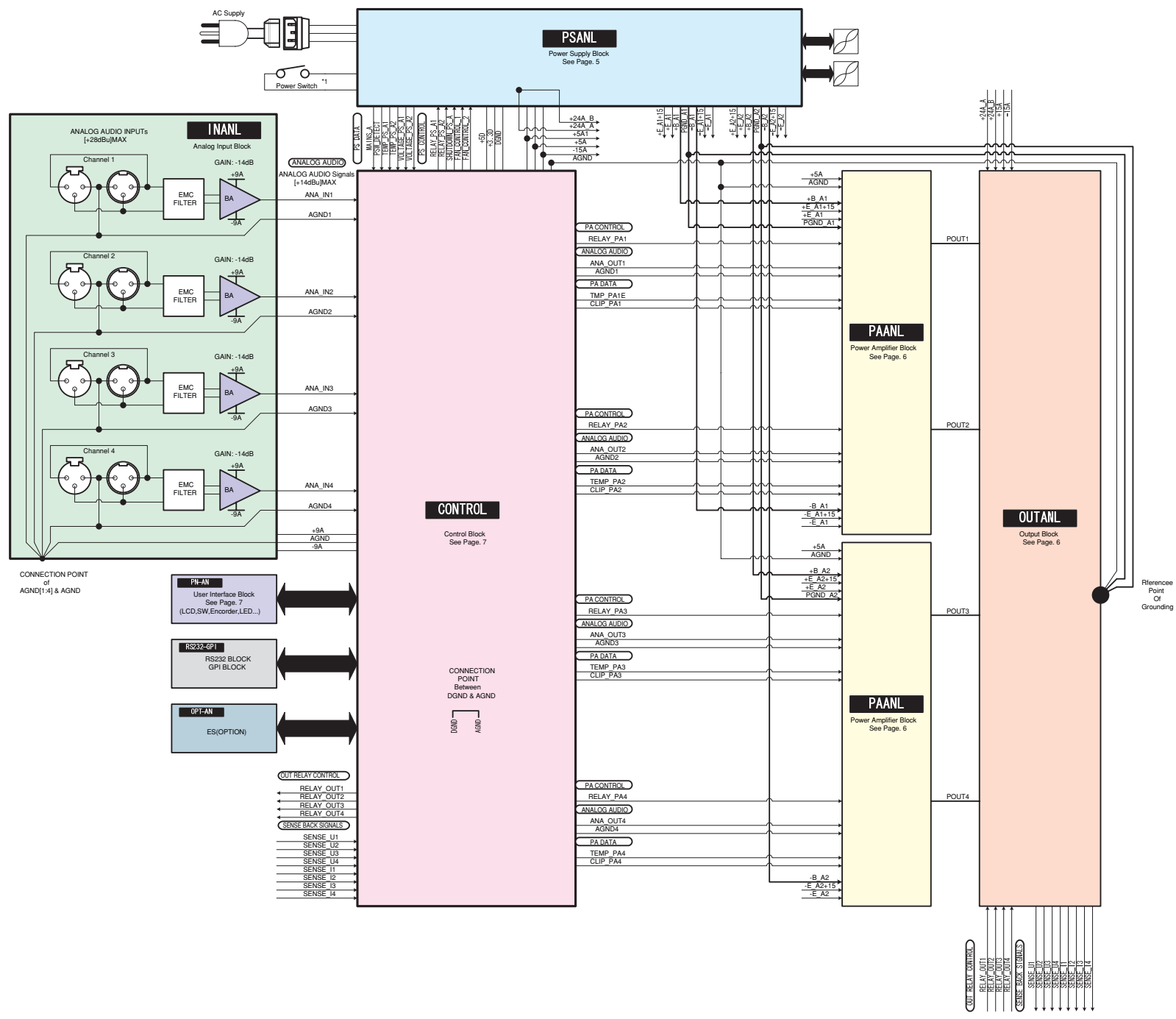

■ BLOCK DIAGRAM 2/5

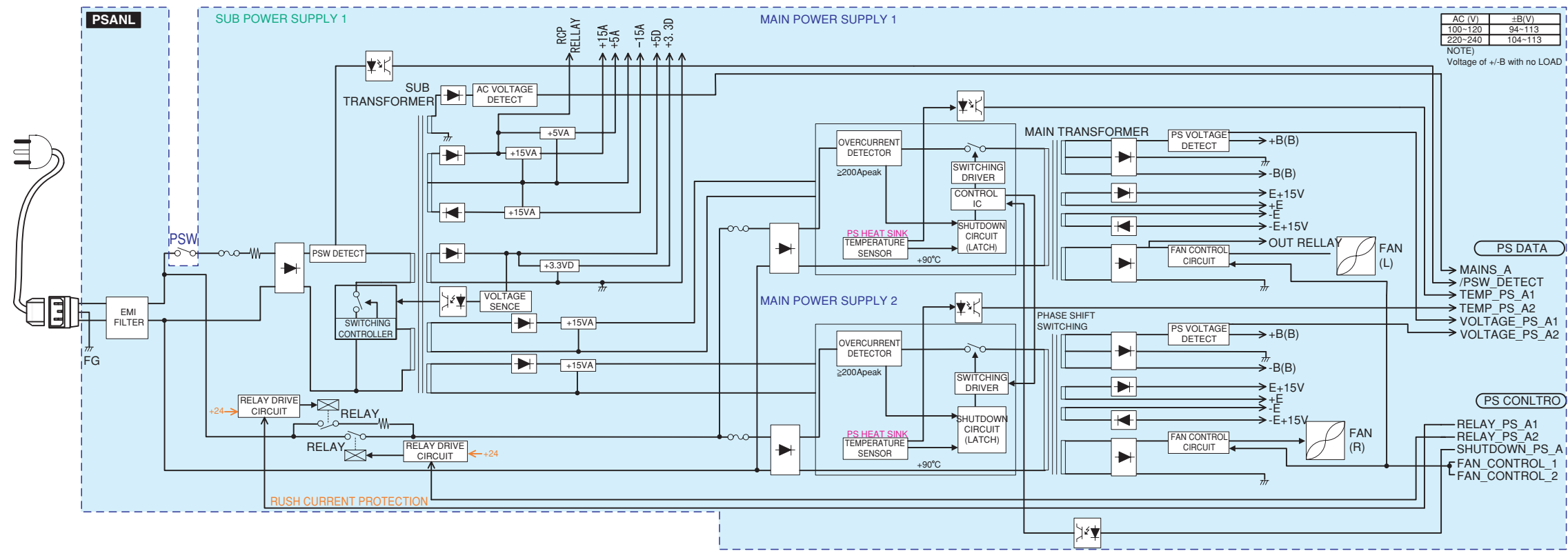

1

2

3

4

5

■ BLOCK DIAGRAM 3/5

PAANL

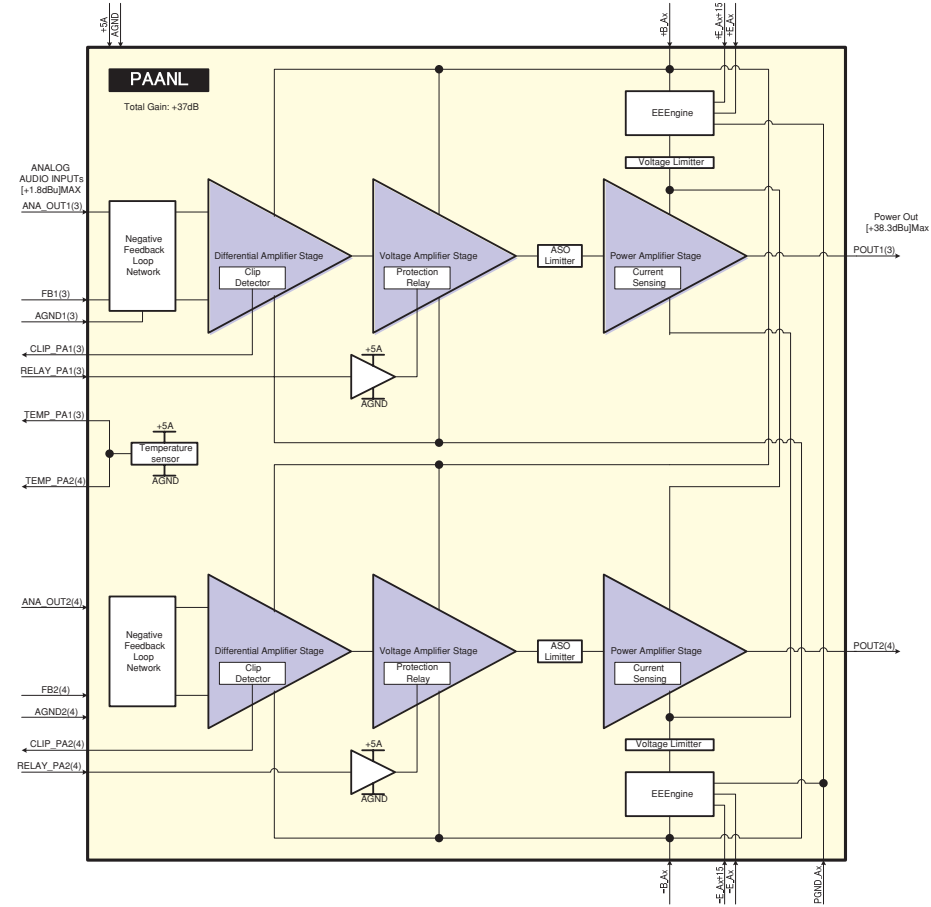

OUTANL

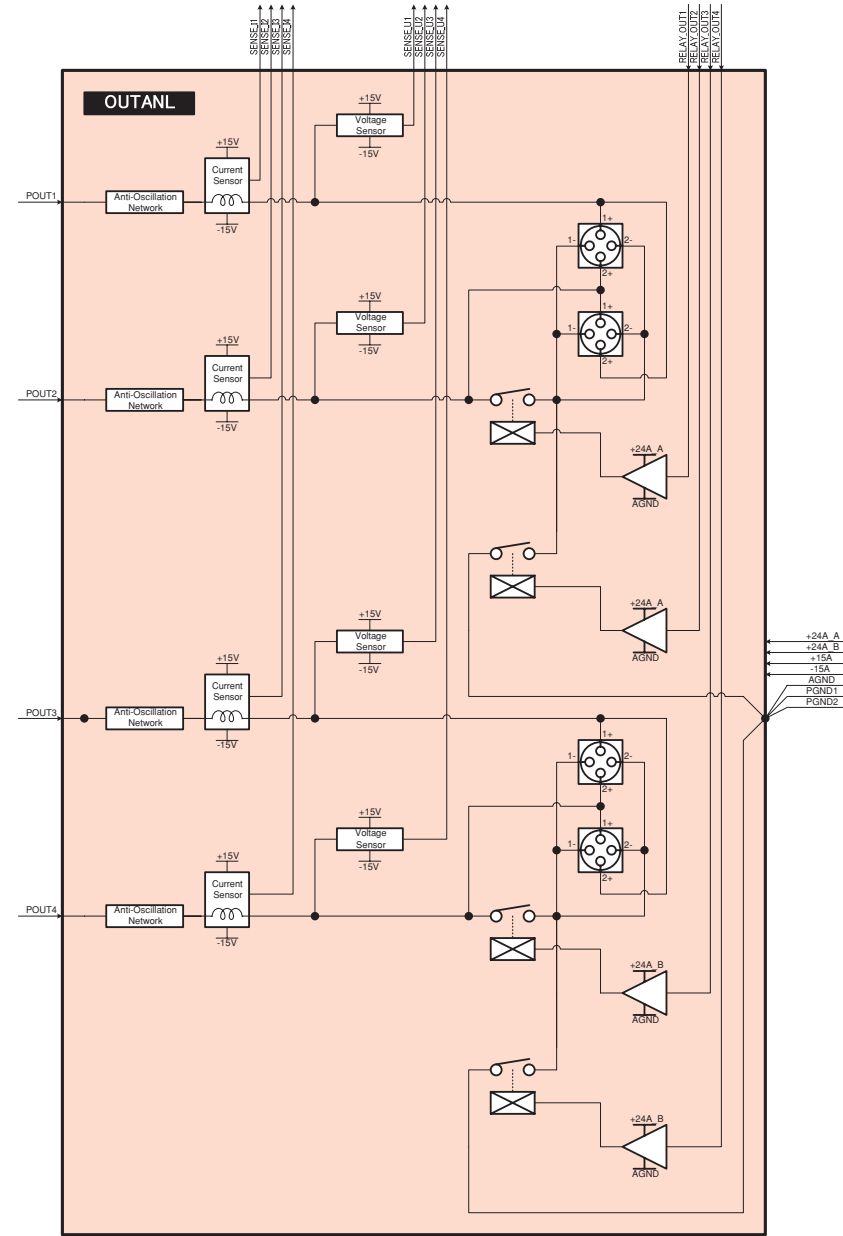

■ BLOCK DIAGRAM 4/5

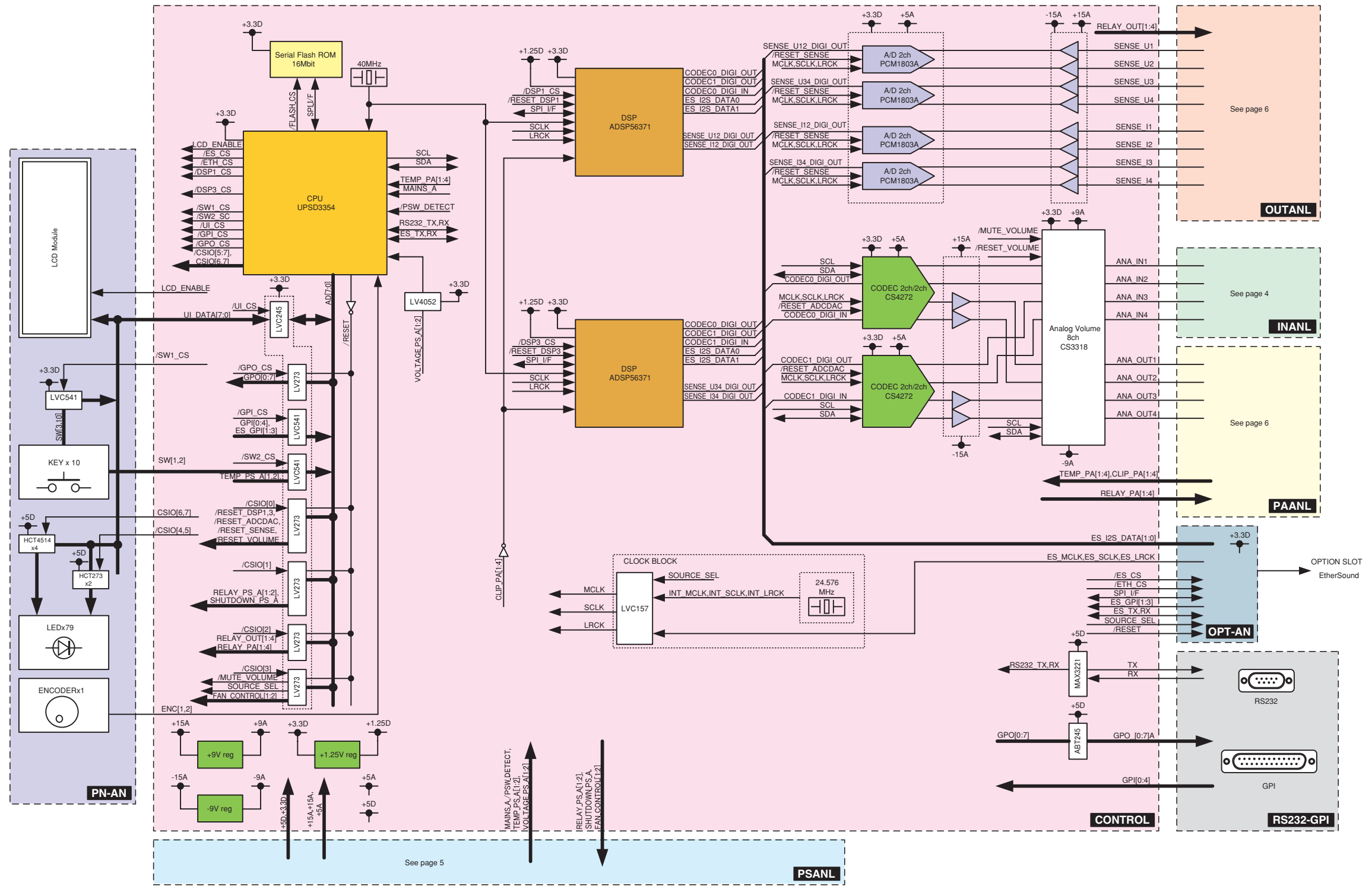

See page 5

See page 6

See page 4

See page 6

■ BLOCK DIAGRAM 5/5

NXAMP4x1 LEVEL DIAGRAM

This level diagram is for the purpose of circuit design only.
The actual gain structure will depend on the firmware that is used.

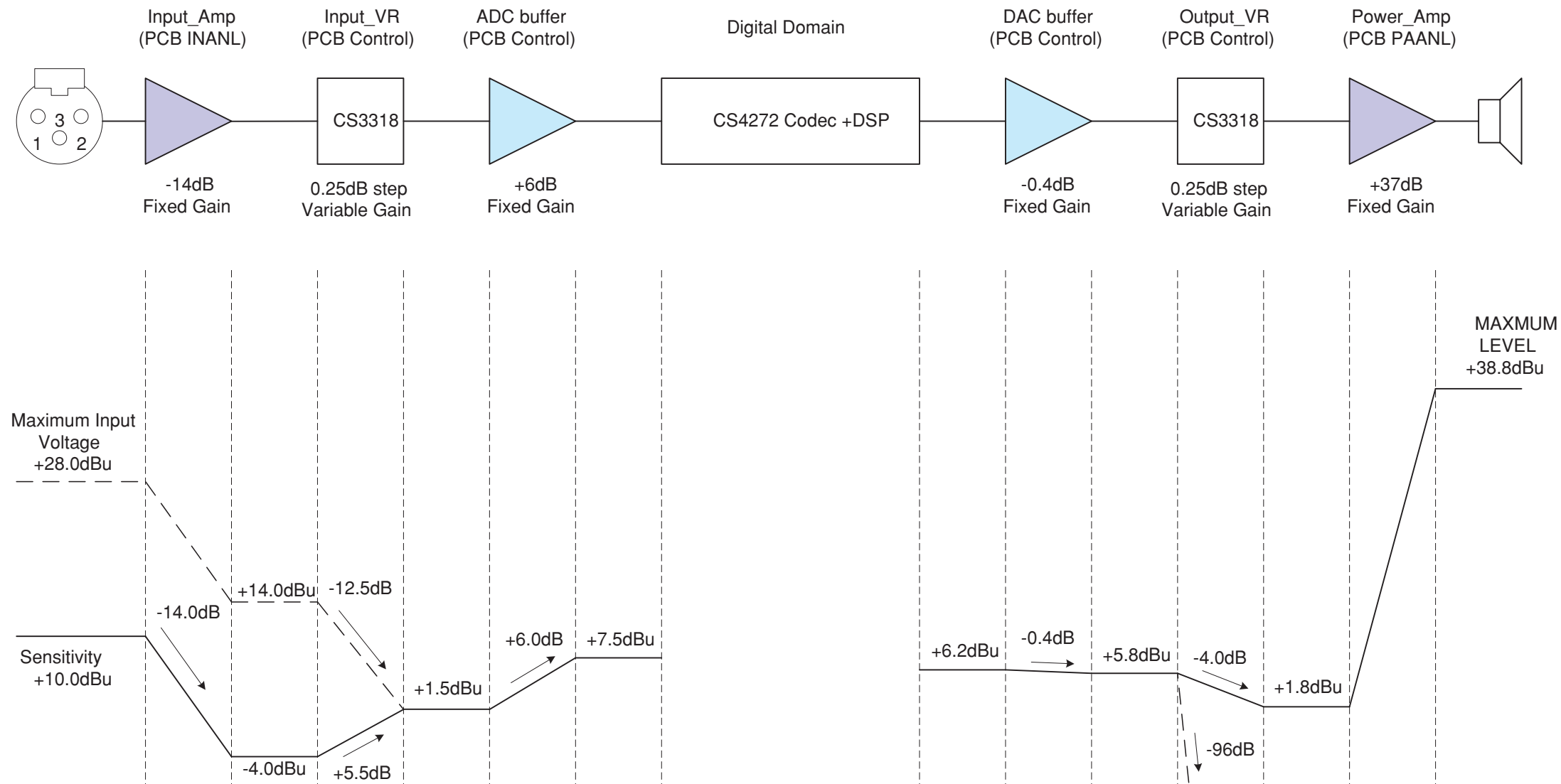

Note:

The solid line shows the gain structure in the analog test mode of the test program mode.
The broken line shows an example in the setting that allows the maximum input signal level.

CIRCUIT DIAGRAM 1/15 (CONTROL 1/6)

VOLUME_CONTROL

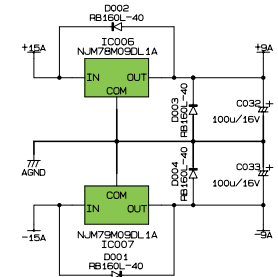
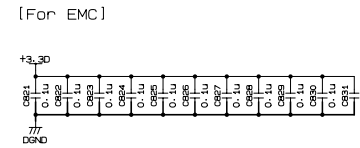
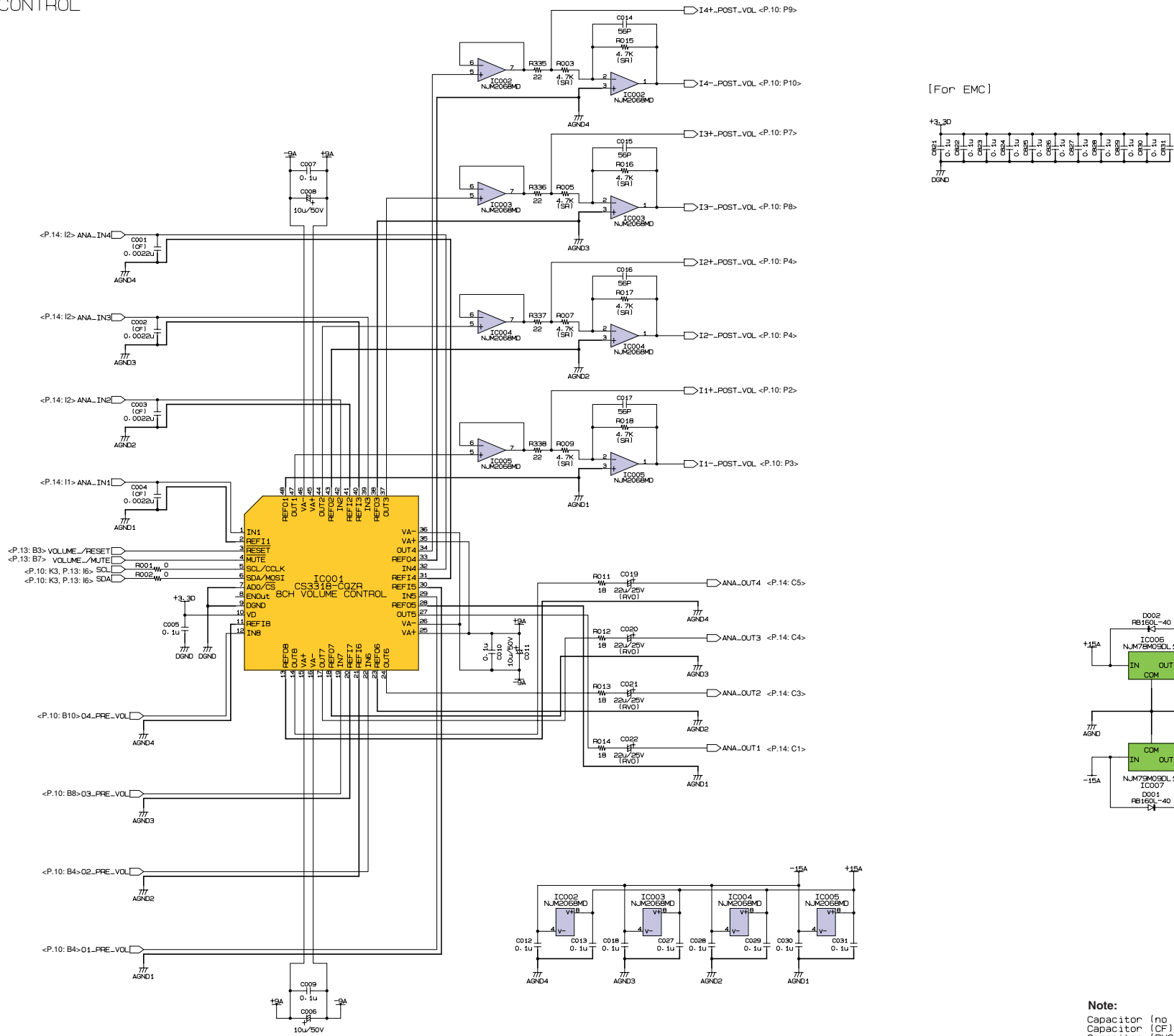

Note:
Capacitor (no mark):Multilayer Ceramic Chip Capacitor
Capacitor (CF):Polyester Film Chip Capacitor
Capacitor (RVO):High Quality Sound Electrolytic Capacitor
Resistor (no mark):Fixed Thick Film Chip Resistor 1608
Resistor (SR):SUSUMU Fixed Metal Film Chip Resistor 1608 0.5%
See parts list for details of circuit board component parts.

CIRCUIT DIAGRAM 2/15 (CONTROL 2/6)

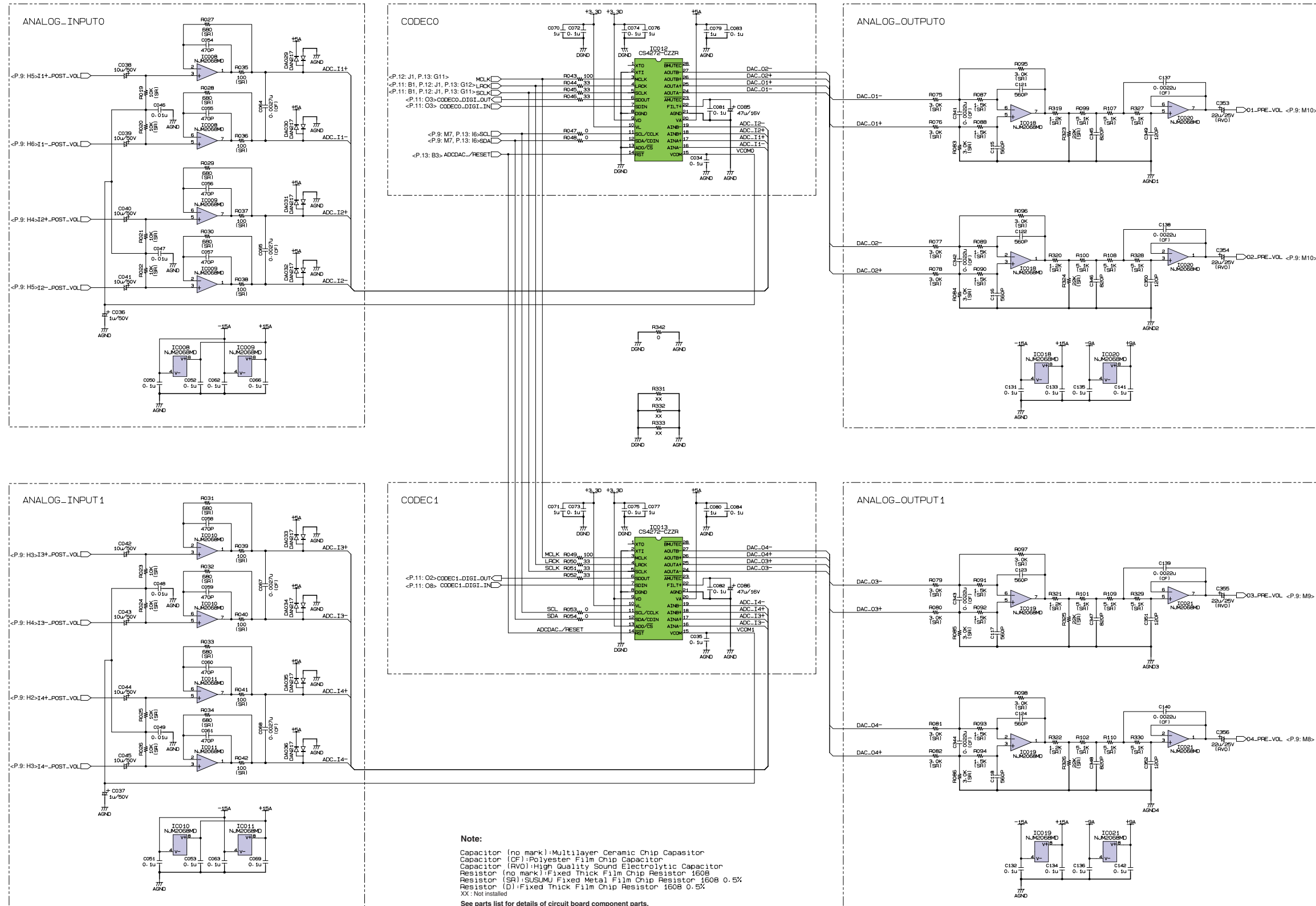

CIRCUIT DIAGRAM 3/15 (CONTROL 3/6)

DSP_BLOCK

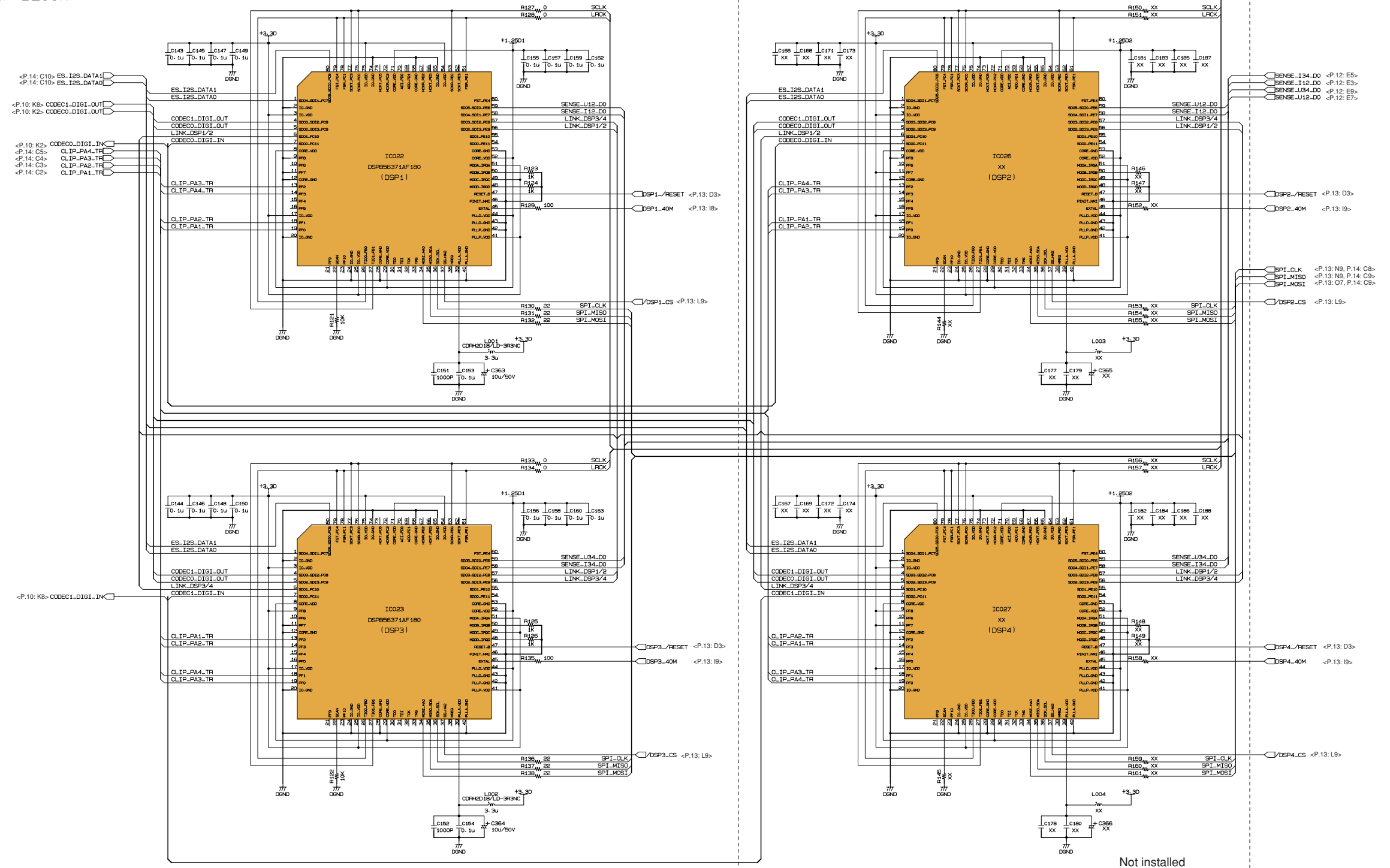

Note:
 Capacitor (no mark): Multilayer Ceramic Chip Capacitor
 Resistor (no mark): Fixed Thick Film Chip Resistor 1608
 XX: Not installed
 See parts list for details of circuit board component parts.

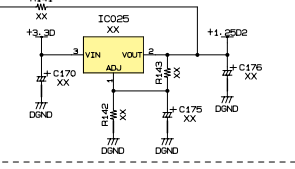
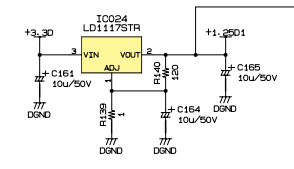

Not installed

CIRCUIT DIAGRAM 4/15 (CONTROL 4/6)

SENSE_BACK

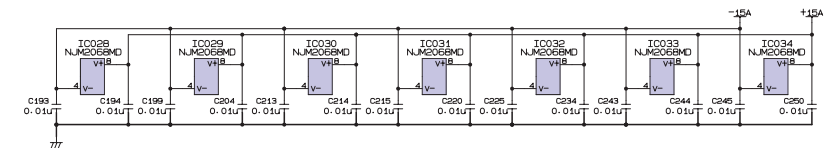
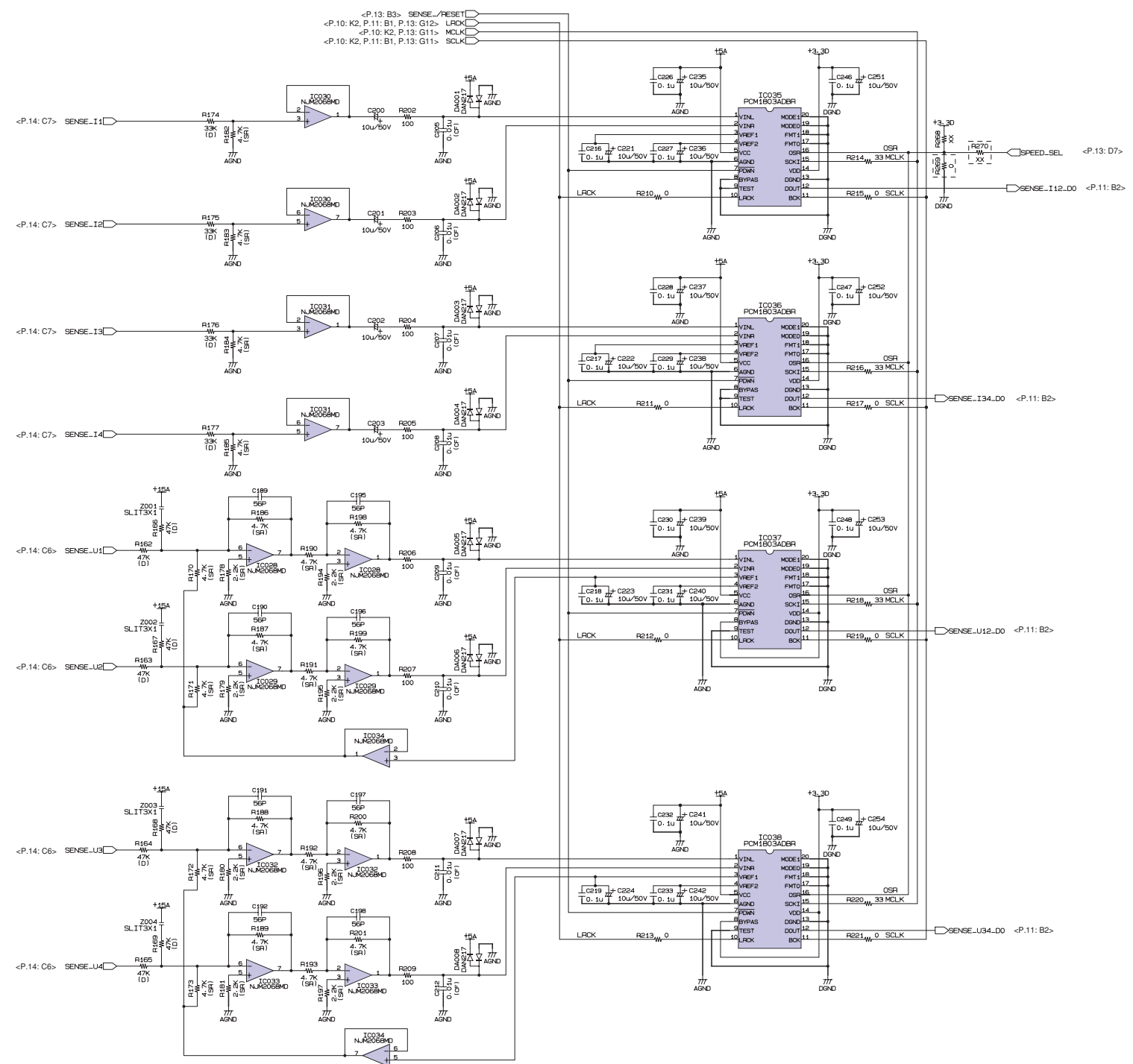

Note:
 Capacitor (no mark): Multilayer Ceramic Chip Capacitor
 Capacitor (CF): Polyester Film Chip Capacitor
 Resistor (no mark): Fixed Thick Film Resistor 1608
 Resistor (SR): SUSLUMJ Fixed Metal Film Chip Resistor 1608 0.5%
 Resistor (D): Fixed Thick Film Chip Resistor 1608 0.5%
 XX: Not installed
 See parts list for details of circuit board components.

CIRCUIT DIAGRAM 5/15 (CONTROL 5/6)

CPU Peripheral

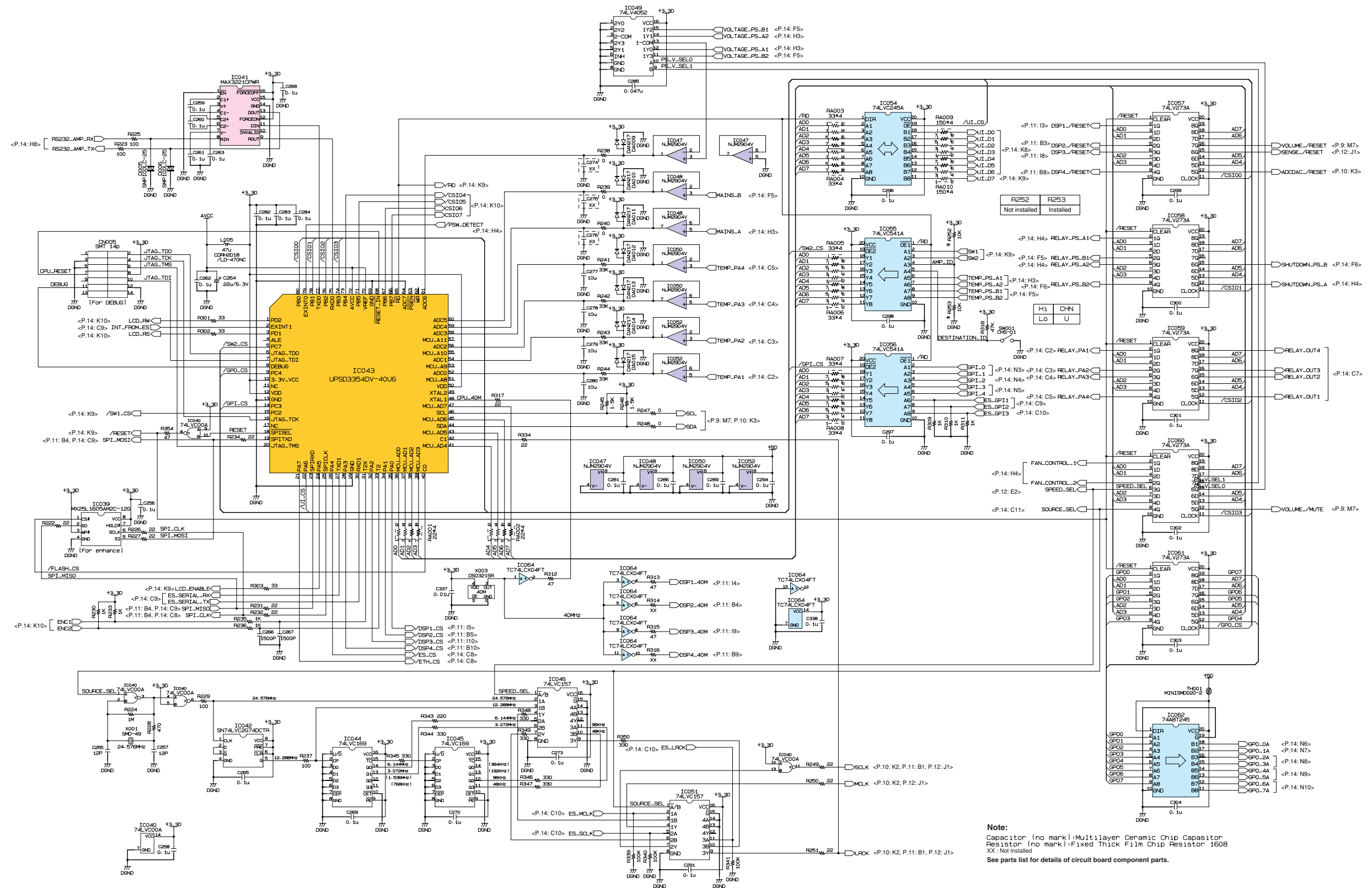

Note:
 Capacitor (no mark): Multilayer Ceramic Chip Capacitor
 Resistor (no mark): Fixed Thick Film Chip Resistor 1608
 XX: Not installed
 See parts list for details of circuit board component parts.

CIRCUIT DIAGRAM 6/15 (CONTROL 6/6)

GPIO

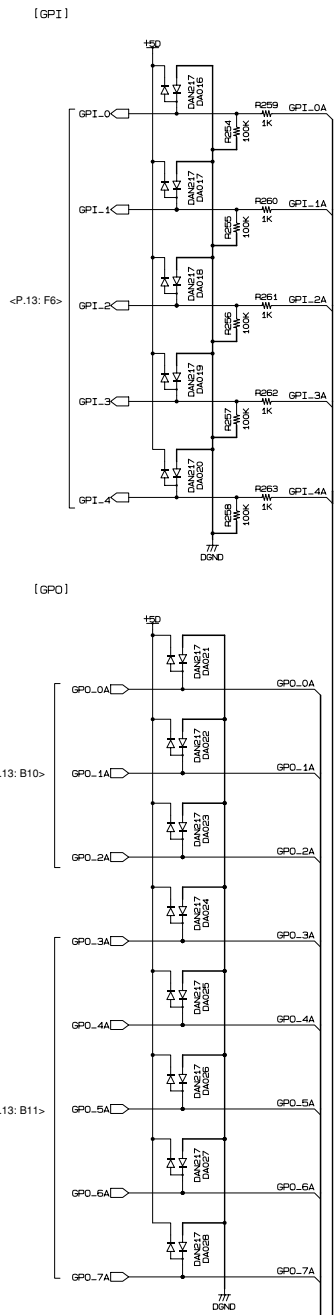

CONNECTOR

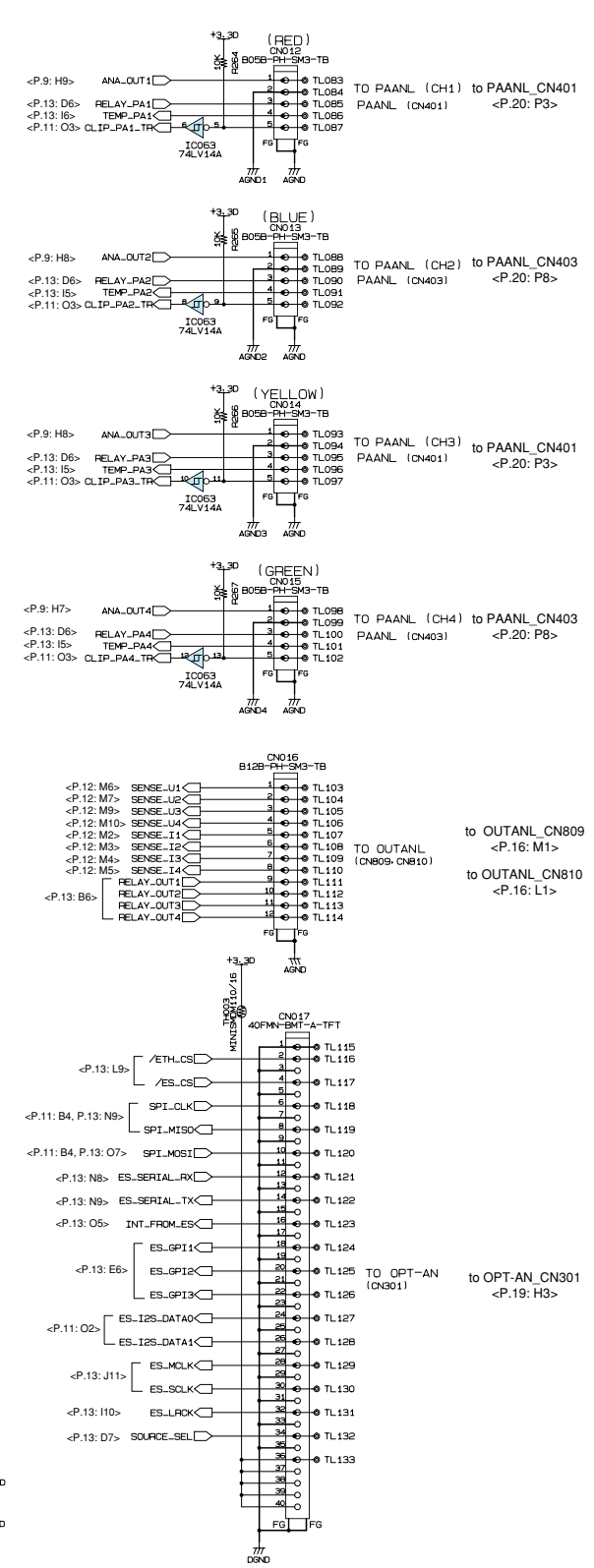
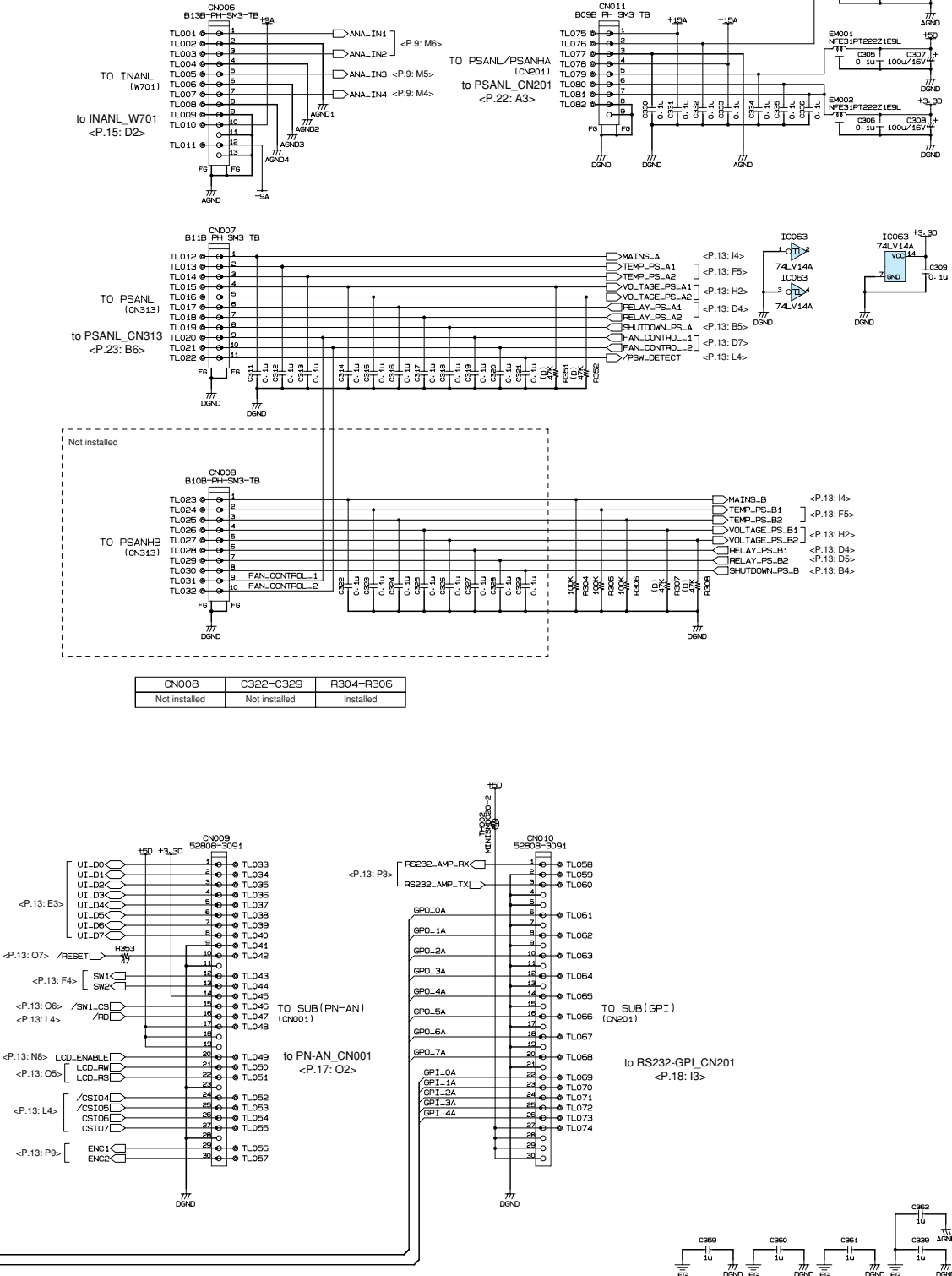

Note:
 Capacitor (no mark): Multilayer Ceramic Chip Capacitor
 Resistor (no mark): Fixed Thick Film Chip resistor 1608
 See parts list for details of circuit board component parts.

■ CIRCUIT DIAGRAM 7/15 (INANL)

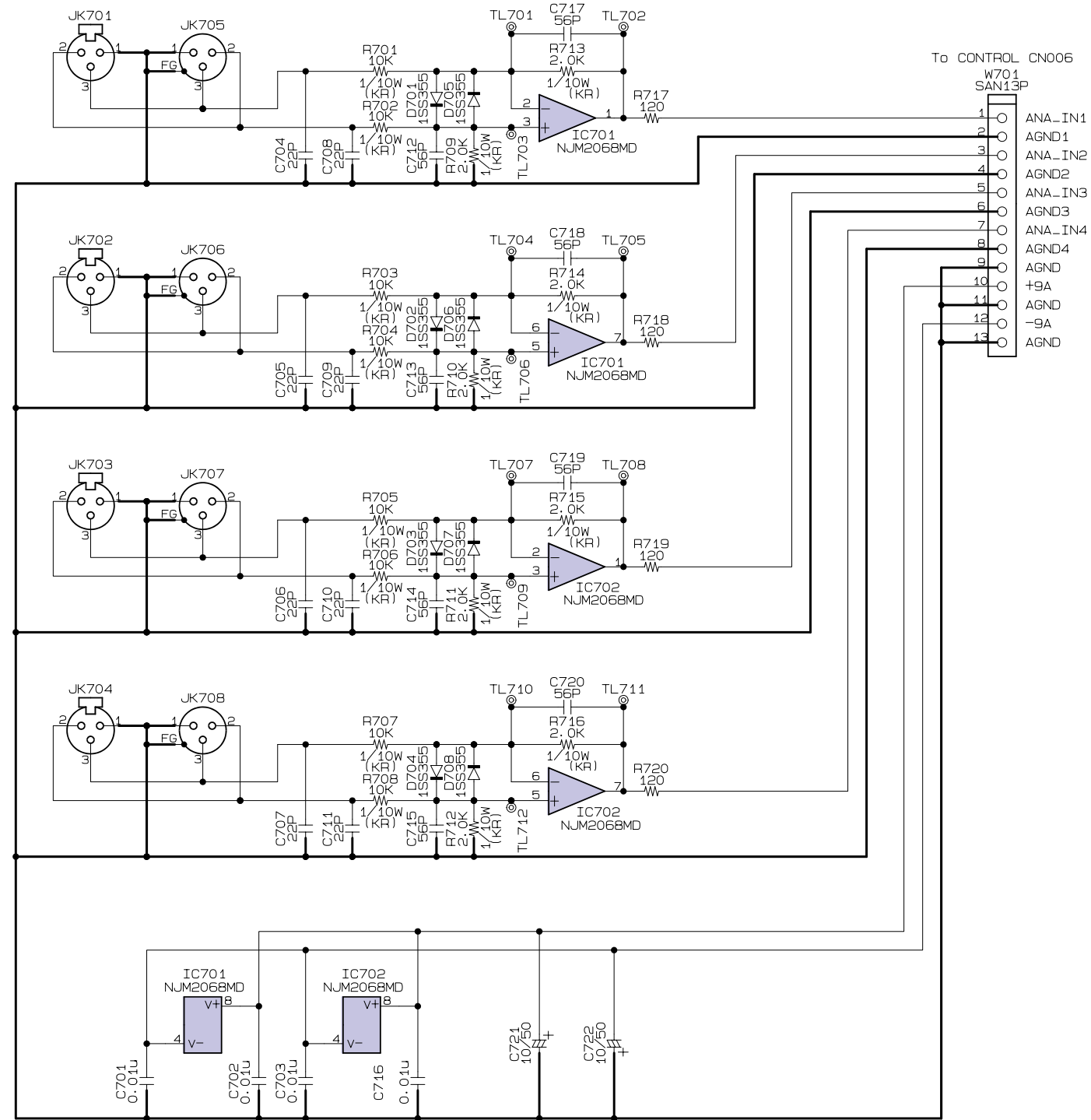

to CONTROL_CN006
<P.14: J2>

Note:

(KR)	KAMAYA Thick Film Chip Resistor 2125 0.5%
R:no mark	Fixed Thick Film Chip Resistor 1608
C:no mark	Multilayer Ceramic Chip Capacitor

See parts list for details of circuit board component parts.

1

2

3

4

5

6

CIRCUIT DIAGRAM 8/15 (OUTANL)

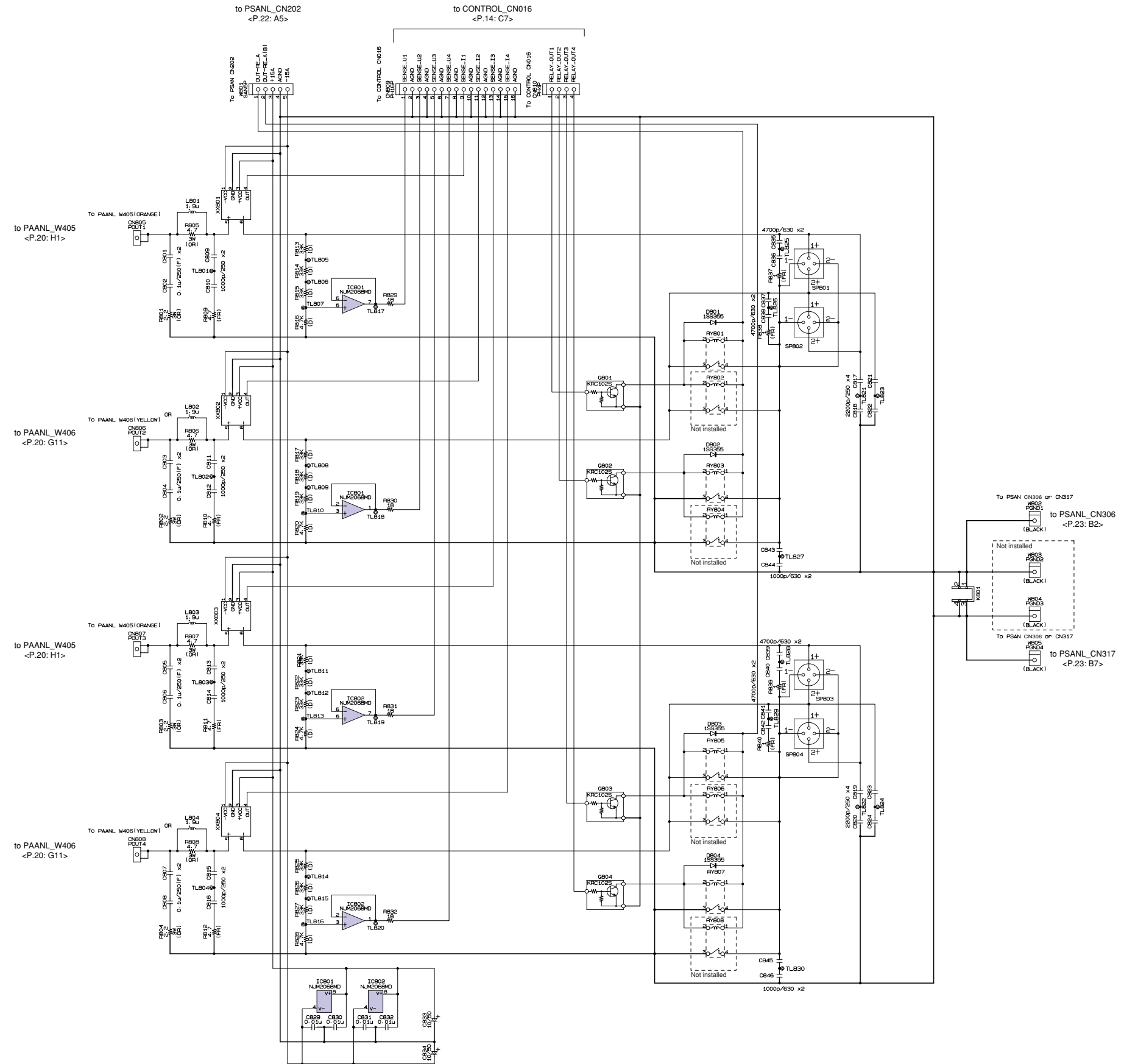

Note:
 (R) Fixed Metal Oxide Film Resistor
 (FR) Fixed Carbon Film Resistor Flame Retardant Type
 (D) Fixed Thick Film Chip Resistor 1608 0.5%
 (F) Polyester Film Capacitor
 Rino mark Fixed Thick Film Chip Resistor 1608
 Cino mark Multilayer Ceramic Chip Capacitor
 See parts list for details of circuit board component parts.

CIRCUIT DIAGRAM 9/15 (PN-AN)

PN-AN

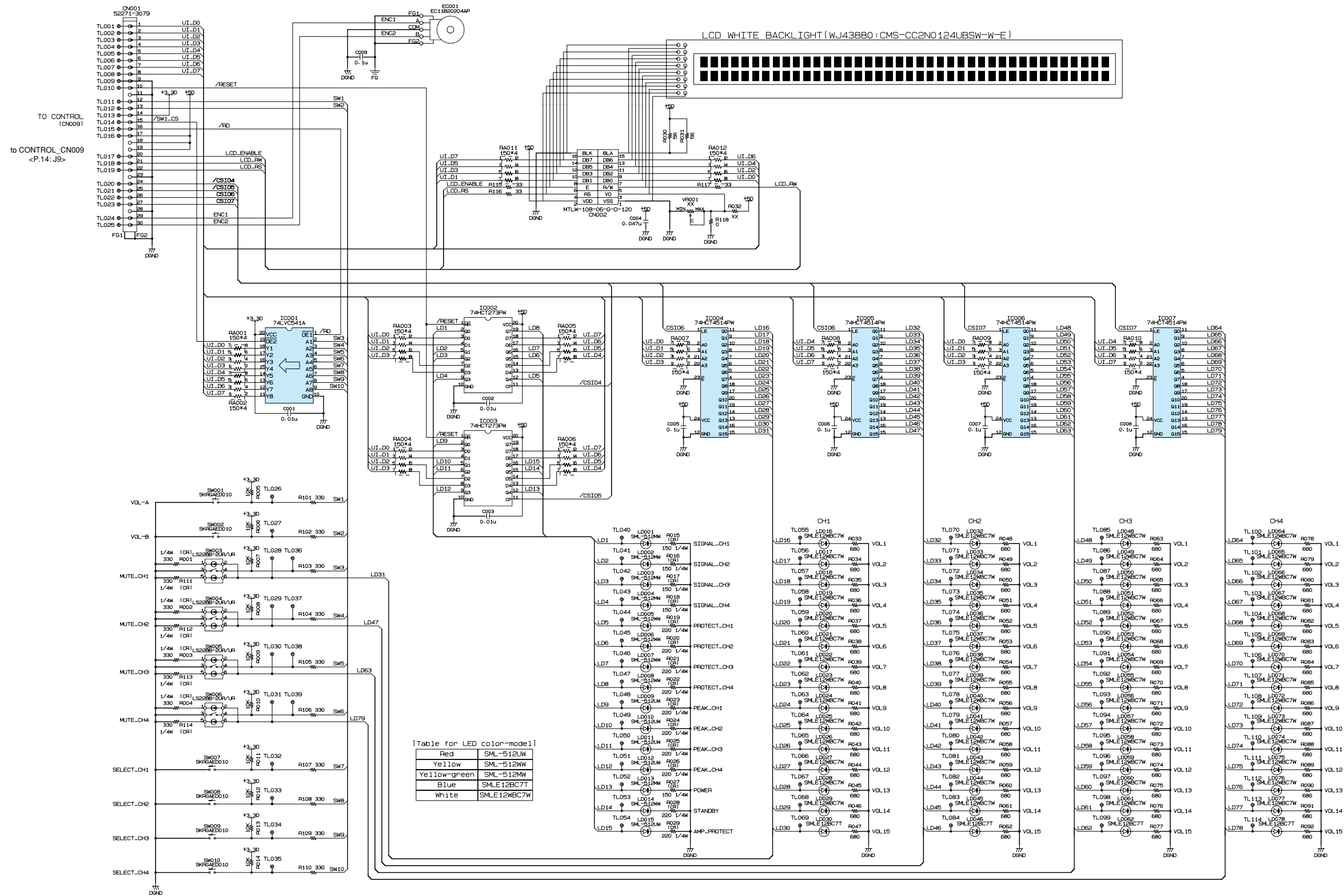

[Table for LED color-model]

Red	SML-512JW
Yellow	SML-512WW
Yellow-green	SML-512MW
Blue	SML-E12BC7T
White	SML-E12WC7T

Note:
 Capacitor (no mark): Multilayer Ceramic Chip Capacitor
 Resistor (CR): Fixed Thick Film Chip Resistor 3216
 Resistor (no mark): Fixed Thick Film Resistor 1608
 XX: Not installed
 See parts list for details of circuit board component parts.

■ CIRCUIT DIAGRAM 10/15 (RS232-GPI)

GPI

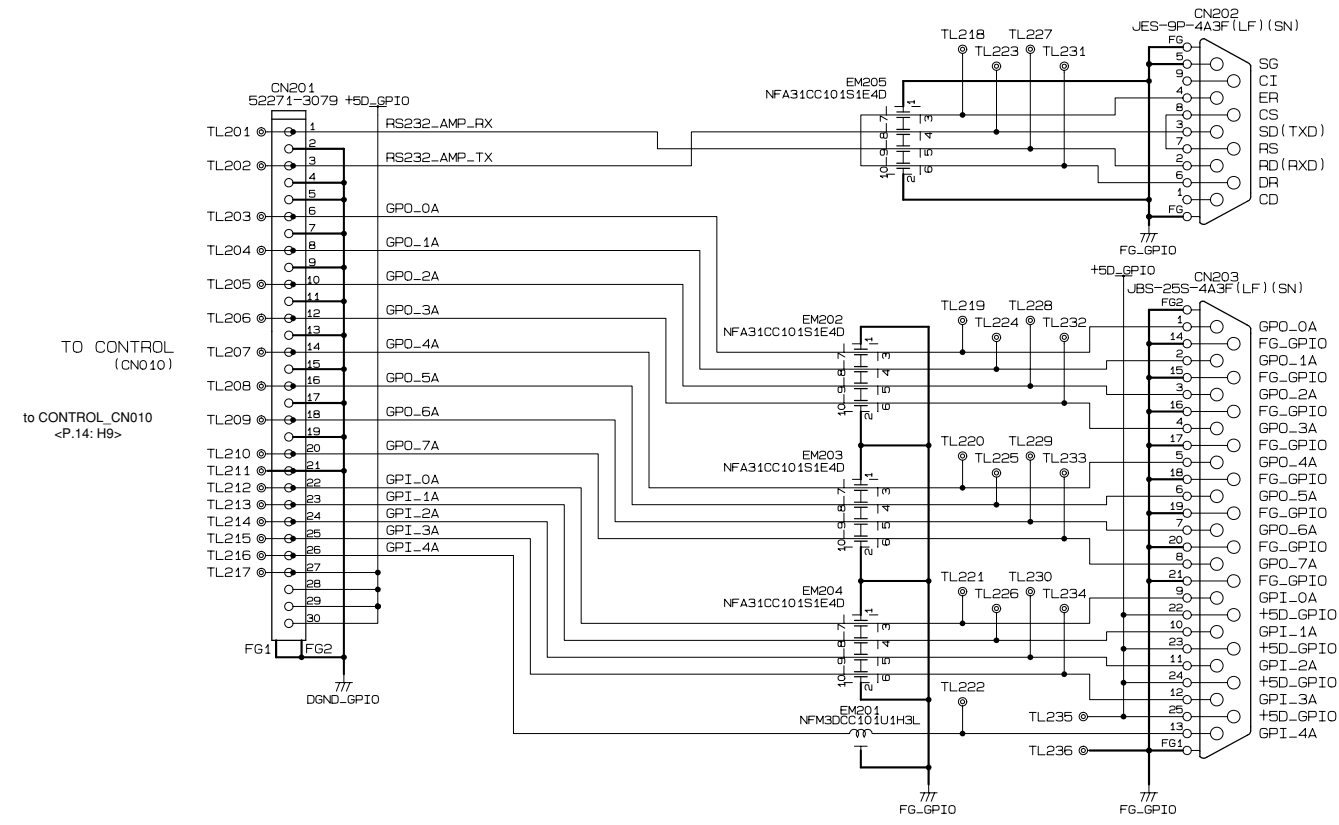

TO CONTROL (CN010)
to CONTROL CN010 <P.14: H9>

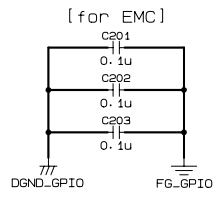

Note:
Capacitor (no mark): Multilayer Ceramic Chip Capacitor
See parts list for details of circuit board component parts.

CIRCUIT DIAGRAM 11/15 (OPT-AN)

OPT-AN

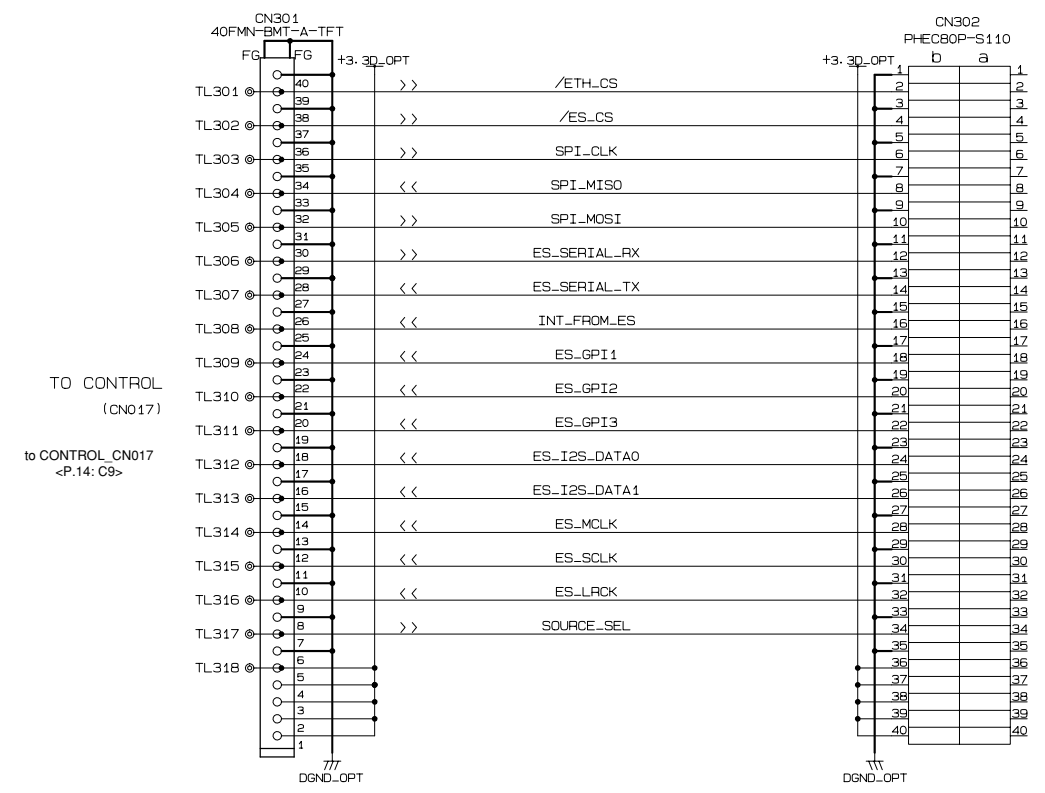

Note: See parts list for details of circuit board component parts.

CIRCUIT DIAGRAM 12/15 (PAANL)

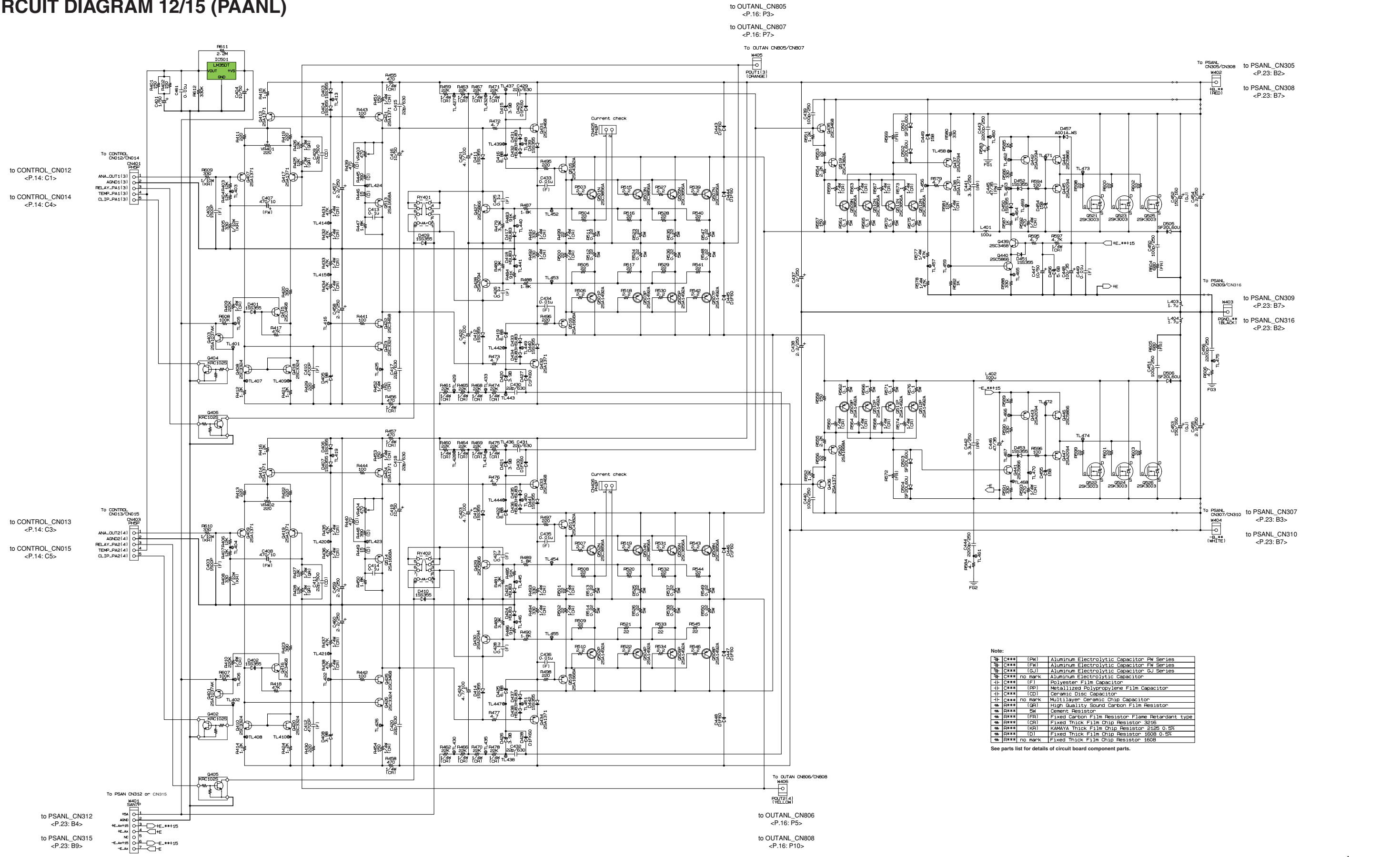

Note:

# C*** (FW)	Aluminum Electrolytic Capacitor FW Series
# C*** (FW)	Aluminum Electrolytic Capacitor FW Series
# C*** (GJ)	Aluminum Electrolytic Capacitor GJ Series
# C*** no mark	Aluminum Electrolytic Capacitor
# C*** (F)	Polyester Film Capacitor
# C*** (PP)	Metallized Polypropylene Film Capacitor
# C*** (CD)	Ceramic Disc Capacitor
# C*** no mark	Multilayer Ceramic Chip Capacitor
# R*** (RF)	High Quality Sound Carbon Film Resistor
# R*** (SW)	Cement Resistor
# R*** (FR)	Fixed Carbon Film Resistor Flame Retardant Type
# R*** (CR)	Fixed Thick Film Chip Resistor 3216
# R*** (KH)	KAMAYA Thick Film Chip Resistor 2126 0.5%
# R*** (D)	Fixed Thick Film Chip Resistor 1608 0.5%
# R*** no mark	Fixed Thick Film Chip Resistor 1608

See parts list for details of circuit board component parts.

CIRCUIT DIAGRAM 13/15 (PSANL 1/3)

: Important safety parts

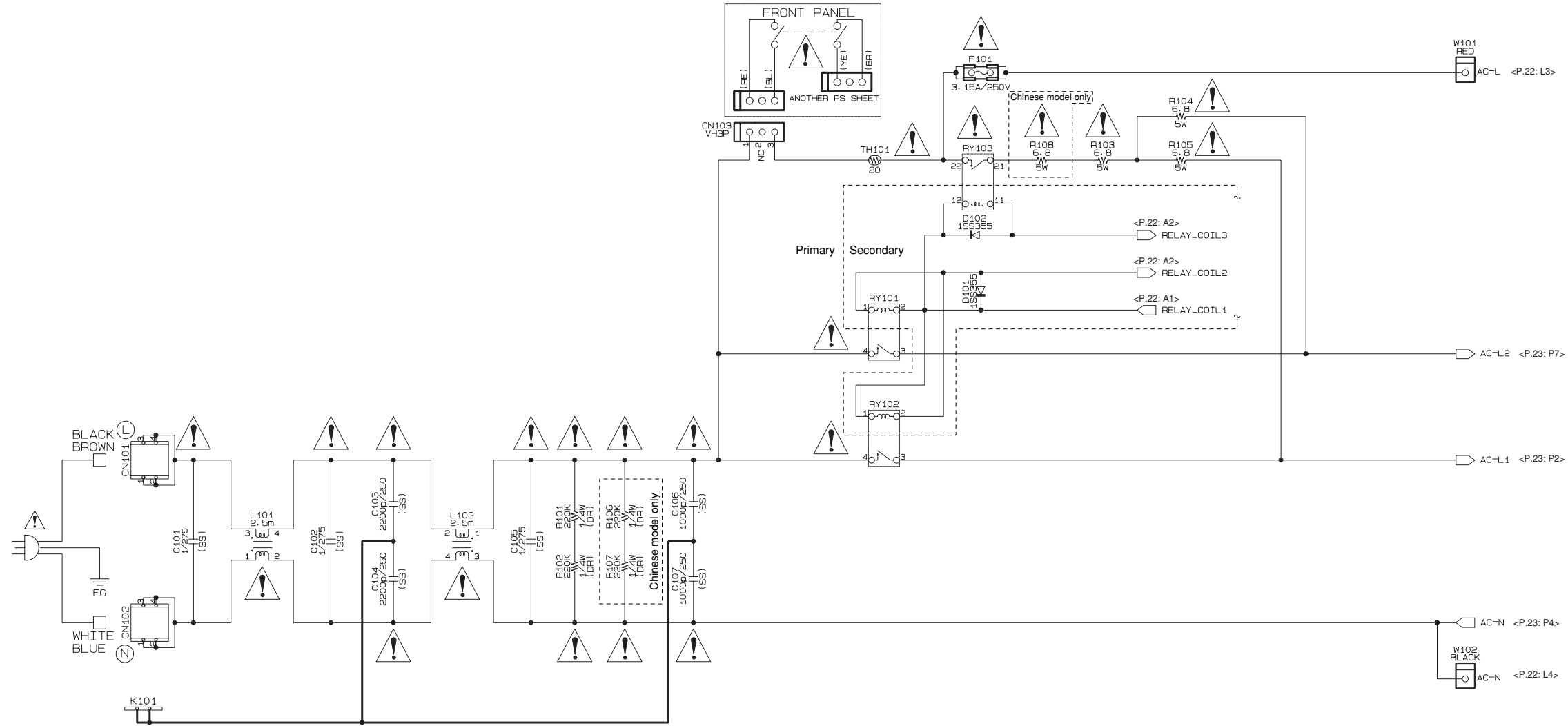

Note:

(SS)	Safety Standard Recognized Ceramic Capacitor
(DR)	Fixed Carbon Film Resistor
5W	Cement Resistor

See parts list for details of circuit board component parts.

1

2

3

4

5

6

7

8

CIRCUIT DIAGRAM 14/15 (PSANL 2/3)

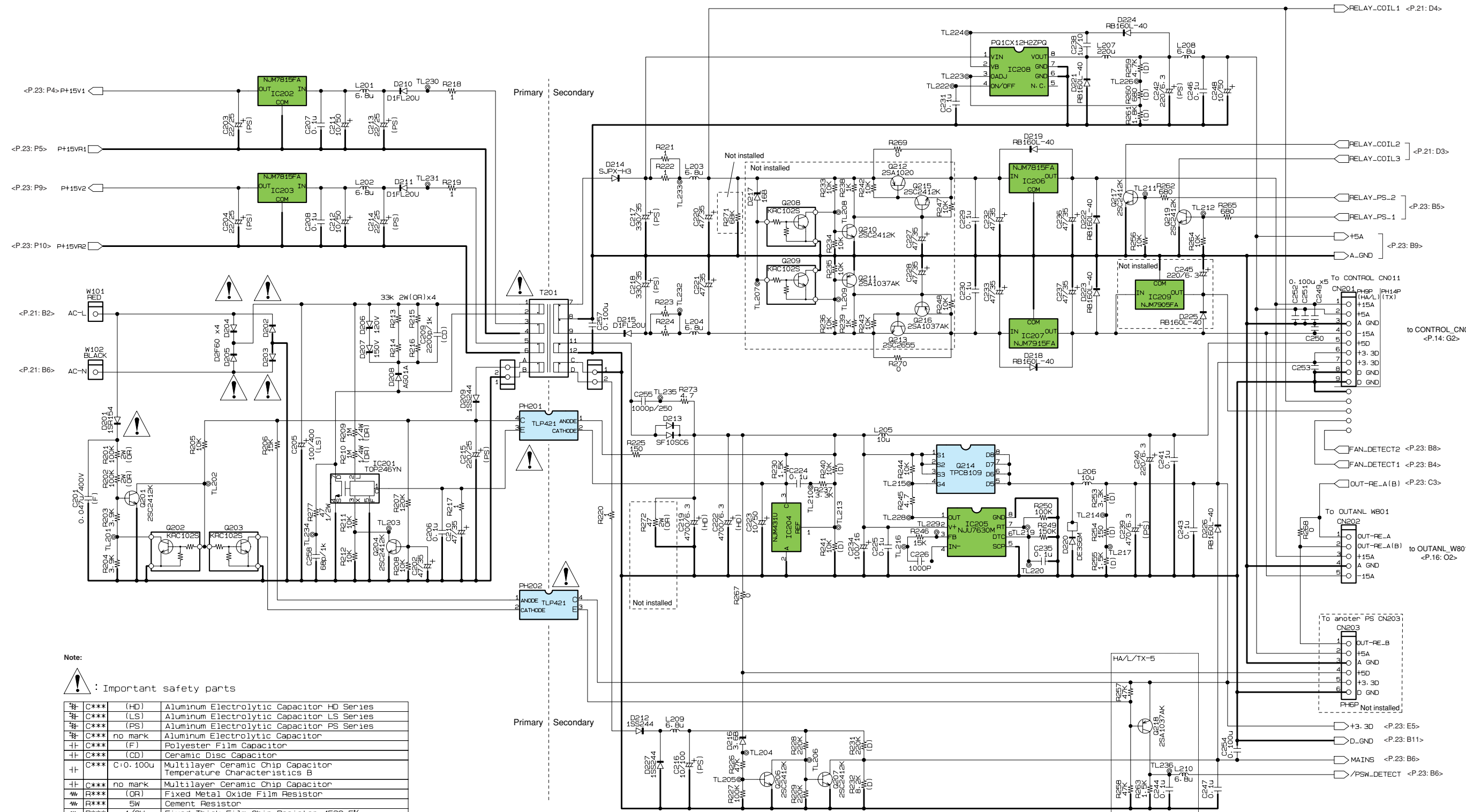

Note:

⚠ : Important safety parts

⚡	C*** (HD)	Aluminum Electrolytic Capacitor HD Series
⚡	C*** (LS)	Aluminum Electrolytic Capacitor LS Series
⚡	C*** (PS)	Aluminum Electrolytic Capacitor PS Series
⚡	C*** no mark	Aluminum Electrolytic Capacitor
⚡	C*** (F)	Polyester Film Capacitor
⚡	C*** (CD)	Ceramic Disc Capacitor
⚡	C*** C:0.100u	Multilayer Ceramic Chip Capacitor Temperature Characteristics B
⚡	C*** no mark	Multilayer Ceramic Chip Capacitor
⚡	R*** (OR)	Fixed Metal Oxide Film Resistor
⚡	R*** 5W	Cement Resistor
⚡	R*** 1/2W	Fixed Thick Film Chip Resistor 4532 5%
⚡	R*** (D)	Fixed Thick Film Chip Resistor 1608 0.5%
⚡	R*** no mark	Fixed Thick Film Chip Resistor 1608

See parts list for details of circuit board component parts.

CIRCUIT DIAGRAM 15/15 (PSANL 3/3)

⚠ Important safety parts

*1: Ts=85°C (This part is fixed to Heat sink of IGBT.)

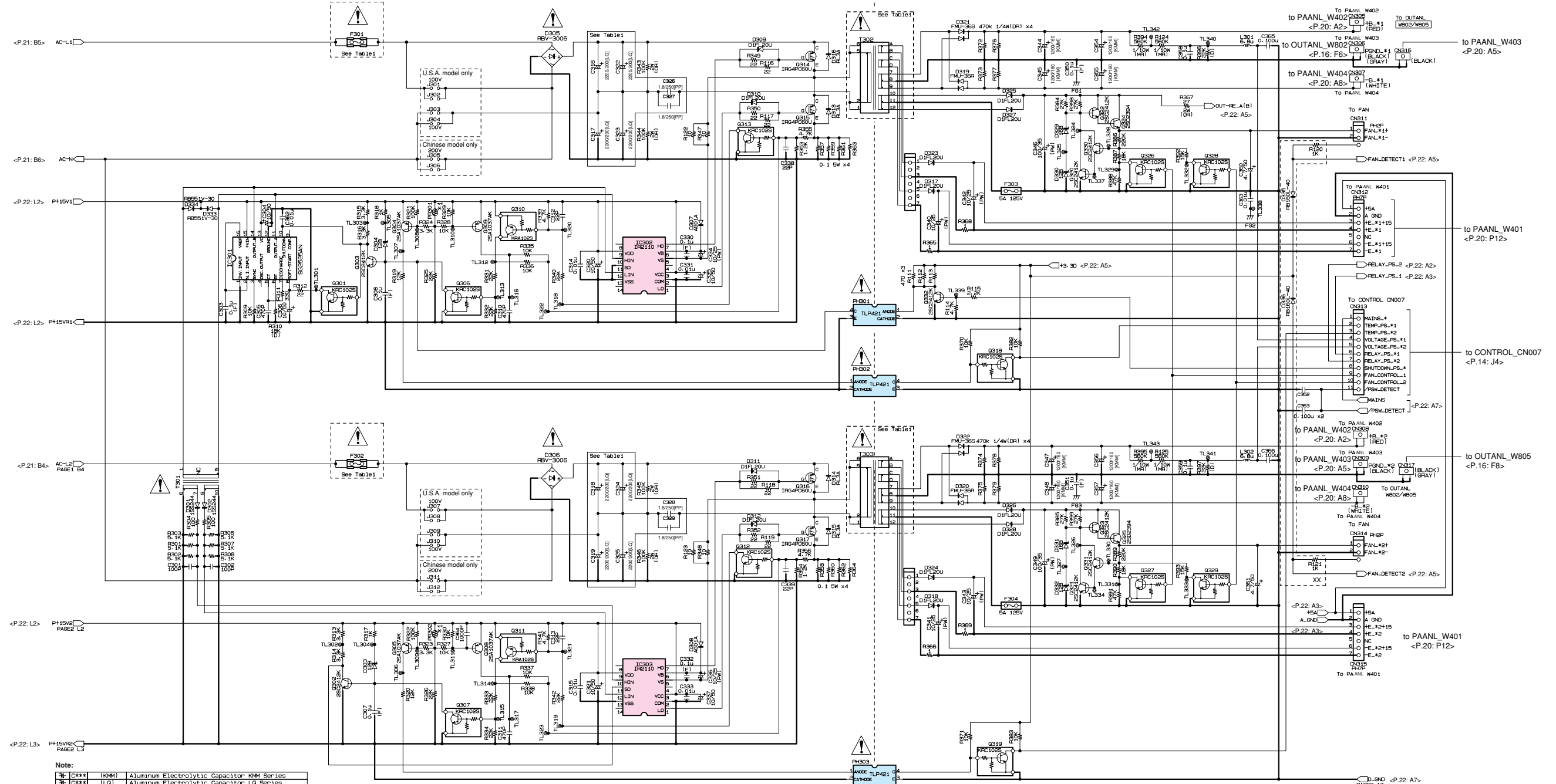

Note:

⊗ C*** (KM)	Aluminum Electrolytic Capacitor KM Series
⊗ C*** (LQ)	Aluminum Electrolytic Capacitor LQ Series
⊗ C*** (PW)	Aluminum Electrolytic Capacitor PW Series
⊗ C*** no mark	Aluminum Electrolytic Capacitor
⊗ C*** (F)	Polyester Film Capacitor
⊗ C*** (PP)	Metallized Polypropylene Film Capacitor
⊗ C*** C:0.100u	Multilayer Ceramic Chip Capacitor Temperature Characteristics B
⊗ C*** no mark	Multilayer Ceramic Chip Capacitor
⊗ R*** (OR)	Fixed Metal Oxide Film Resistor
⊗ R*** SW	Cement Resistor
⊗ R*** (HF)	NATSUB-HIA Thick Film Chip Resistor 2125 0.5%
⊗ R*** (D)	Fixed Thick Film Chip Resistor 1608 0.5%
⊗ R*** no mark	Fixed Thick Film Chip Resistor 1608

XX : Not installed
See parts list for details of circuit board component parts.

Table1

PCB ASSY	F301	T302	±B
PSANL_U	F302	T303	
PSANL_CN	Y10A*250V	X8548A0	±115V
			±105V

POWERED TD CONTROLLER

NXAMP4x1
