

INSPECTION

1. Range of Application

These specifications apply to the DSP1D and DSP1D-EX.

2. Preparations

2-1. Conditions

- ◇ For details on the connection method, refer to the Test Program Specifications KES-92651.
- ◇ The function generator used for inspection must be the Sony Tektronix AFG310 or equivalent. When using the AFG310, the settings are as follows.

```

FUNC      :PULS
MODE      :CONT
MODUL     :OFF
AMPL      :1.800
OFFSET    :0.900
    
```

- ◇ Unless otherwise specified, the conditions are as follows.
 - The function generator BNC output is connected to WORD CLOCK IN (BNC).
 - Set WORD CLOCK IN to 75 Ω.

2-2. Loading the Firmware

The firmware used must be the “CS1D Firmware” (managed with the already drawn CD-R assembly drawing (3JL-XY714A0) of the FMID System Software matching the version on the cover sheet. For details on the firmware writing method, refer to the Test Program Specifications KES-92651.

2-3. Test Program

For details on the starting method etc., refer to the Test Program Specifications KES-92651.

2-4. Jigs

The altered jigs and cable circuit diagram are shown from Page 47 of the Test Program Specifications KES-92651.

3. Inspection

3-1. Inspection with Test Program

- Inspect based on the Test Program Specifications KES-92651.

3-2. Jitter Measurement

- Connect the jitter meter to the WORD CLOCK OUT terminal.
- Set the function generator to 48 kHz and 44.1 kHz, connect to WORD CLOCK IN, and measure the jitter with the jitter meter.

	Range of tolerance
48 kHz	6 ns max.
44.1 kHz	5 ns max.

3-3. Fan Operation Check

- Check that the fan rotates while the power is on.

3-4. Sound

- For the connections and settings, refer to the Test Program Specifications.

(1) Fs = 51.12 kHz (48 kHz + 6.5 %)

- Set the function generator to 51.12 kHz.
- Test listen for 30 seconds and verify that there is no noise.

(2) Fs = 39.69 kHz (44.1 kHz -10 %)

- Set the function generator to 39.69 kHz.
- Test listen for 30 seconds and verify that there is no noise.

4. Factory Settings

- Rear panel.

WORD CLOCK IN 75 Ω: ON

TEST PROGRAM

A. Preparations for Inspection

This equipment requires firmware. When there are changes to the manufacturing processes and program for this equipment, it is necessary to write the new firmware to FlashRom from a PC. The software used and firmware used and their version numbers and concrete details of the writing method are shown below.

•PM1DLOAD installation

First, it is necessary to install in the PC the dedicated software for writing the firmware. For the installation method, refer to the CS1D Test Program Specifications.

Software used:	PM1DLOAD within PM1D system software
Version used:	PM1D system software component files with the version number listed on the cover sheet. (Managed with the already drawn CD-R assembly drawing (3JL-XY714A0.))

•Writing the firmware

The sheets that require firmware downloading are CIB (the 2CPU portion of E_TUC/E_HIF), EMB (the 2CPU portion of EMU/UIF), PDB, GDB, IDB (the 2CPU portion of DSP1D-EX), and EDB.

Below is the firmware used. Detailed procedures are on the following pages.

Firmware used:	DSP1D firmware in PM1D system software
Version used:	PM1D system software component files with the version number listed on the cover sheet. (Managed with the already drawn CD-R assembly drawing (3JL-XY714A0.))

* If PM1DLOAD has been installed according to the instructions in the CS1D Test Program Specifications, the version for the firmware above is taken care of and there is no need to worry about it.

	Firmware name	Sheet name	Connection number for writing firmware independently
1	EMU	EMB	CN104
2	E_TCU	CIB	CN105
3	E_HIF		CN107
4	UIF	EMB	CN105
5	PDB	PDB	CN100
6	GDB	GDB	CN100
7	IDB1	IDB (1st sheet)	CN100
8	IDB2	IDB (2nd sheet)	CN100
9	EDB	EDB	CN100

“Firmware” and “subject sheet and subject connector” correspondence table

•Method for writing firmware using the CS1D or DSP1D RS232C port

* It is possible to write the CPU firmware from the PC via the RS232C port. This is the method normally used.

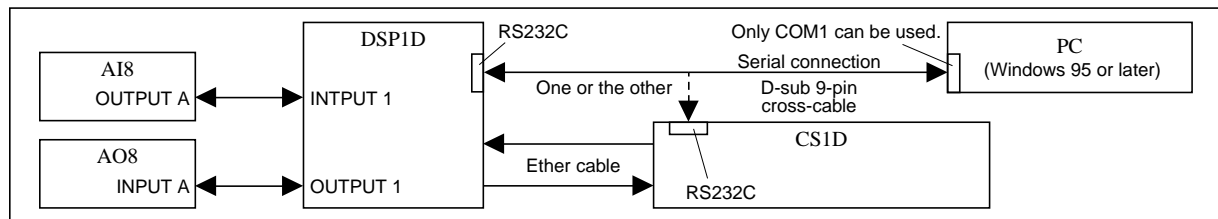

1. Install and set PM1DLOAD with the method given in the CS1D Test Program Specifications.
2. Connect as in the figure above. Do not connect any other signal lines. However, to write firmware just to this equipment for a manufacturing process with this equipment, the only configuration required is DSP1D and the PC.
3. Write the firmware to all the units listed in the CS1D Test Program Specifications. You can check the status of the LEDs on each sheet. After the firmware has been written, check that the versions for all the units are the desired versions.

For PDB, GDB, IDB1, IDB2, and EDB	
MONI-4 flashing	Program not yet written
MONI-4 lit up	Program writing complete Program writing enabled
LED other than MONI-4 flashing or lit up	Program writing complete Program writing inhibited
All LEDs out	Board defect possible

For CIB, EMB	
LED flashing	Program not yet written
LED lit up	Program writing complete Ready for program writing
LED off	Program writing complete Not ready for program writing

Corresponding LEDs { CIB (E_TCU: LD101, E_HIF: LD102)
EMB (EMU: LD101, UIF: LD102)

•Method for writing firmware directly to each sheet

* When there is some kind of problem and the firmware can not be written with the method on the previous page, use the method below.

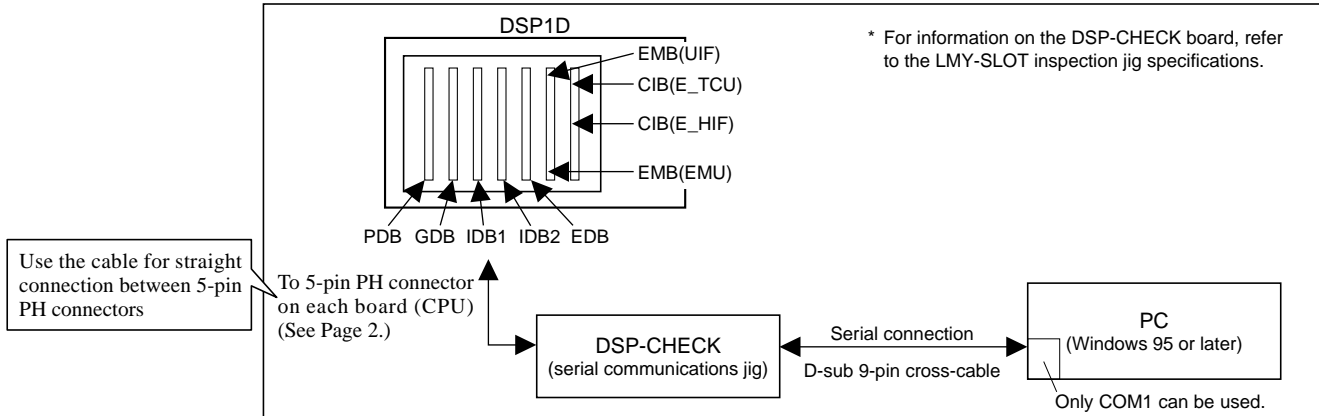

1. Install and set PM1DLOAD with the method given in the CS1D Test Program Specifications.
2. Remove the DSP1D front panel.
3. Remove all the CPU boards except the one on which you want to write PDB. (When writing to PDB, leave only that board.)
4. Connect the D-sub 9-pin serial cables (cross) and DSP-CHECK board between the 5-pin connector for the target board and the PC. At this time, do not connect other signal lines.

• For PDB, GDB, IDB1, IDB2, and EDB

5. Short Pin 1 of the target CPU directly to ground.
6. With the connections still as in 4., switch on the power for the DSP1D. If the LED darkens momentarily, you can remove the short.
7. Check that the LED on the board is lit or flashing, indicating that the system is ready for writing. (See the previous page.)
8. After starting PM1DLOAD, select CardDirect with MODE SELECT, then press OK.
9. Press the Update button on the DSP1D.
10. Select the desired firmware, then press the Write button. (See Page 45.)
11. After writing ends, end PM1DLOAD.
12. Switch off DSP1D. Remove the PH connector, then switch the power for DSP1D on again and check that it starts up normally.

• For EMB, CIB

5. Switch on the power for the DSP1D.
6. Check that the LED on the board is lit or flashing, indicating that the system is ready for writing. (See the previous page.)
7. After starting PM1DLOAD, select CardDirect with MODE SELECT, then press OK.
8. Press the Update button on the DSP1D.
9. Select the desired firmware, then press the Write button. (See Page 45.)
10. After writing ends, end PM1DLOAD.
11. Switch off DSP1D. Remove the PH connector, then switch the power for DSP1D on again and check that it starts up normally.

•PM1D inspection PC software preparation

Inspection with this device uses special PC software for inspection.

The version of the software used is shown below.

Firmware used: PM1D inspection PC software in PM1D system software
 Version used: PM1D system software component files with the version number listed on the cover sheet.
 (Managed with the already drawn CD-R assembly drawing (3JL-XY714A0).)

* The operating systems supported are Windows 95/98.
 * USB inspection is only supported in Windows 98. (Windows 98 Second Edition is not supported yet.)

For details of the preparation method and execution method, refer to the CS1D Test Program Specifications. Refer to version.txt in the same directory as the firmware on Page 2 and input the version character string exactly as given there. (For details on the input positions, refer to the "PM1D Inspection PC Software Summary" given later in this document.)

•Installing the USB driver for inspection

This equipment has a USB terminal. Therefore, it is necessary to install the USB driver for inspection in the inspection PC. The files used are included in the above PM1D inspection PC software, so install with the following procedure.

1. For the PMID inspection PC software, start 16. DSP1D-JK6, LED2 Test.
 2. When the pop-up box for connecting the USB cable is displayed, connect the USB cable.
 3. After a short while, the system asks you to specify the driver. Specify the directory containing the PMID inspection PC software.
 4. The installation proceeds as indicated by the OS.
 5. After installation is complete, press the OK button on the pop-up box that came up in 2.
 6. If inspection is OK, the installation has completed normally.
- * The only operating system supported is Windows98. The USB driver can not be used with Windows 98 Second Edition.
 - * The USB port is only activated in the state in 2. Beware. If you insert the USB cable in any other state, it is not correctly recognized by the PCS1De and the wrong driver is installed.
 - * Once the driver has been installed, the above procedure is not necessary for USB tests.
 - * This driver is only for inspection. It does not add the DSP1D USB function.
 - * The CS1D inspection USB driver must be installed separately.

B. Inspection Method

The inspection items are given below. Except for 17., these items are inspected using the PMID inspection PC software. For details on each item, see from Page 51 on.

No.	Items	No.	Items
1	CIB Test { 1-1. TCU 1-2. HIF 1-3. CIF	9	Connection test { 9-1. PDB 9-2. GDB 9-3. IDB1 9-4. IDB2 9-5. EDB
2	EMB Test { 2-1. EMU 2-2. UIF	10	JK1 (INPUT x) Test { 10-1. INPUT 1 : 10-10. INPUT 10
3	IFC Test	11	JK4 (TO CONSOLE x) INPUT Test { 11-1. TO CONSOLE 1 11-2. TO CONSOLE 2
4	PDB Test { 4-1. CPU 4-2. DSP6 4-3. DSP5	12	JK2 (OUTPUT x) Test { 12-1. OUTPUT 1 : 12-6. OUTPUT 6
5	GDB Test { 5-1. CPU 5-2. DSP6 5-3. DSP5	13	JK4(TO CONSOLE x) OUTPUT Test { 13-1. TO CONSOLE 1 13-2. TO CONSOLE 2
6	IDB1 Test { 6-1. CPU 6-2. DSP6 6-3. DSP5	14	JK3 (CASCADE) Test
7	IDB2 Test { 7-1. CPU 7-2. DSP6 7-3. DSP5	15	JK5 Test
8	EDB Test { 8-1. CPU 8-2. DSP6	16	JK6 , LED2 Test
		17	All-group sound inspection (Inspects using DSP1D sound inspection data. See Page 49.)

C. Inspection Using PMID Inspection PC Software

Except for the all-group sound test, the inspections use the PMID inspection PC software to control the DSP1D and the inspection is carried out autonomously. The inspection configuration diagram is as follows.

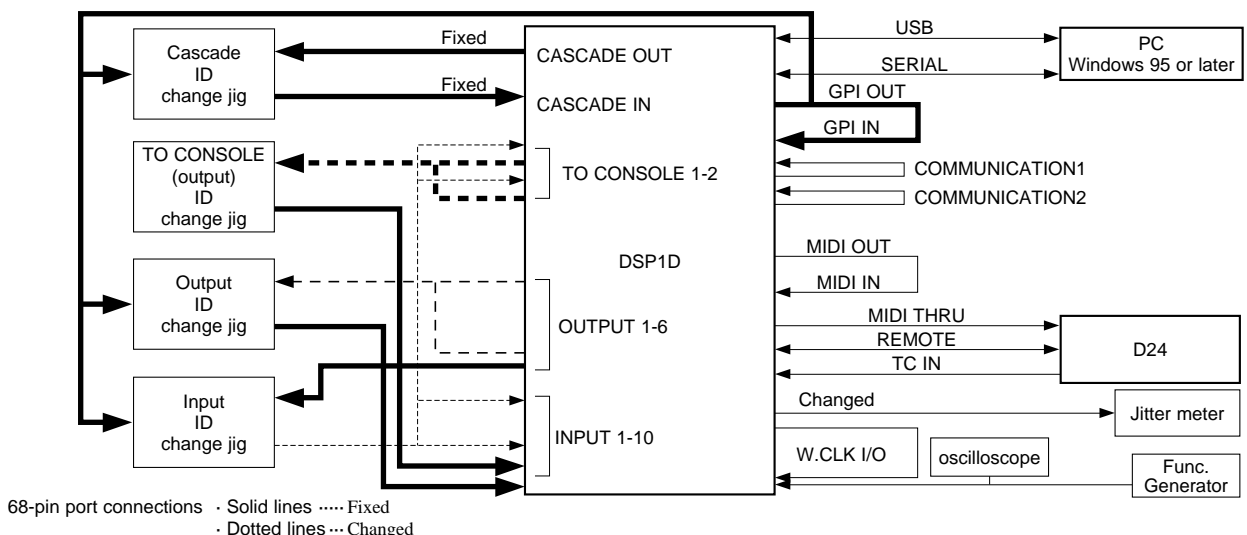

For details on inspecting with this software, see from Page 51 on.

Locations with instructions for changes have instructions for that inspection item in the PC software, so change the connections according to the instructions.

(* Even if the system is the DSP1D not the DSP1D-EX, inspect with IDB2 inserted for the bus check.)

D24 setting method

For time code output, insert an MO disc (song data or the like) that can idle as long as possible. Also, switch On MMC Receive on the Utility menu and set TC Select to Serial IN on the Setup menu.

W. CLK connection method

In the 16 JK6 inspection, it is necessary to change the BNC cable. The connection method is as follows.

JK6-W.CLK inspection sub-item	Connection method
IN 48 kHz + 6 % IN 44.1kHz - 10 %	W.CLK In Connect the function generator and output the clocks. W.CLK Out No need to connect
Jitter 48 kHz Jitter 44.1 kHz	W.CLK In Connect the function generator and output the clocks. W.CLK Out Connect the jitter meter and measure.
IN/OUT	Loopback connection between W.CLK Out and W.CLK In

68-pin port connection method table

* Since the input and output functions are inspected separately for TO CONSOLE, there are two connection methods.

Inspection item	Necessary jig	ID change jig connection method	
		From left side (CN103)	From right side (CN102)
10. INPUT 1-10	Input ID change jig	To INPUT 1-10	To OUTPUT x
11. TO CONSOLE (INPUT) 1-2		To Console 1-2	
12. OUTPUT 1-6	Output ID change jig	To INPUT x	To OUTPUT 1-6
13. TO CONSOLE (OUTPUT) 1-2	Altered ID change jig just for TO CONSOLE (OUTPUT)	Connected TO CONSOLE 1-2 and INPUT; no polarity.	
14. CASCADE IN/OUT	Cascade ID change jig	To CASCADE IN	To CASCADE OUT

ID change jig DIP switch settings

* There are three special 68-pin port ID change jigs (for INPUT, OUTPUT, and CASCADE) but these are the same jig with just the DIP switch settings changed. In other words, you can work with just one ID change inspection jig by changing the DIP switch settings appropriately. For information on the ID change jig, refer to the LMY-SLOT inspection jig specifications.

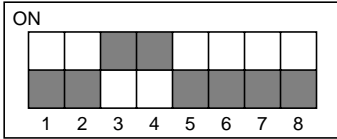
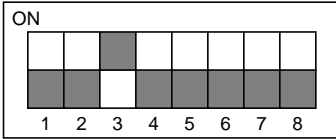
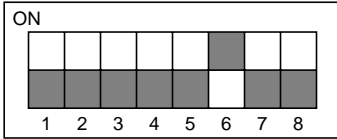
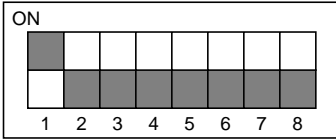
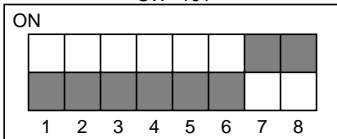
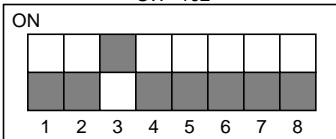
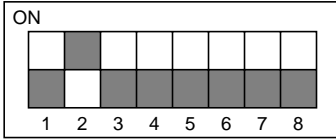
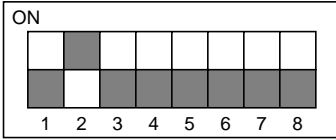
Input ID change jig [INPUT 1-10] [TO CONSOLE (INPUT)]	SW 101 	SW 102 
Output ID change jig [OUTPUT 1-6]	SW 101 	SW 102 
TO CONSOLE (OUTPUT) ID change jig [TO CONSOLE (OUTPUT)]	The ID is not inspected at TO CONSOLE (OUTPUT), so the DIP switch settings do not matter. Connect the altered ID change jig just for TO CONSOLE (OUTPUT). (For details on the alteration, refer to the DSIP Overall Inspection Specifications.)	
Cascade ID change jig [for CASCADE IN check]	SW 101 	SW 102 
Cascade ID change jig [for CASCADE OUT check]	SW 101 	SW 102 

PM1D inspection PC software summary

Except for Item 17., the PM1D is inspected using PC inspection software. This inspection software is common for AI8/AO8/DSP1D/CS1D.

For details on the basic operation methods, menu screen specifications, etc., refer to the CS1D Test Program Specifications.

The DSP test menus are shown below.

Before the inspection, the latest version of each piece of DSP1D software must be input. (This is necessary for the version check.)

For the version character string to be input, refer to version.txt in the same directory as the DSP1D firmware.

The following pages give details on each check item and how the PC software handles it.

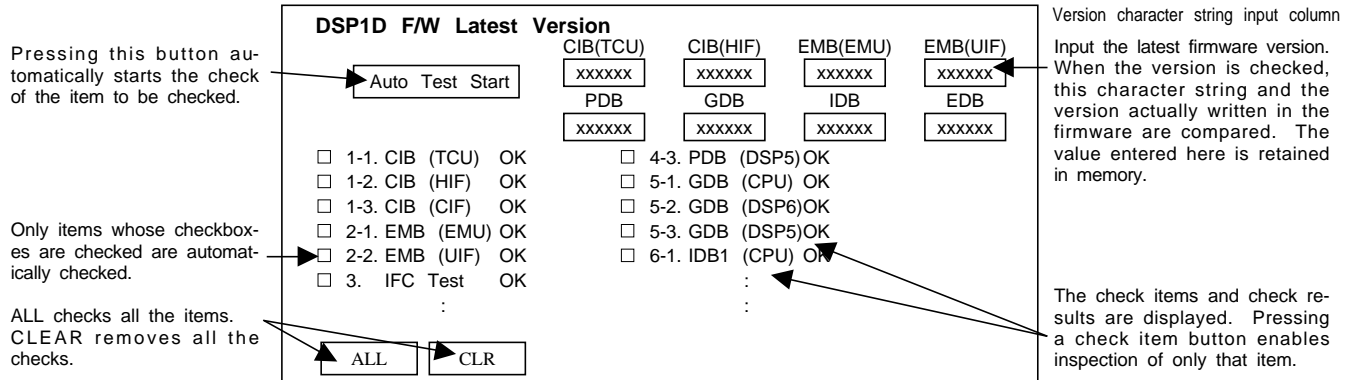

D. All-Group Sound Inspection

After all the inspections were carried out with the PM1D inspection PC software, the sound inspection is carried out.

After making the connections as in the diagram below, inspect with the procedure given from the next page on. Note that the altered ID change jigs A/B are separate from the dedicated TO CONSOLE (OUTPUT) altered ID change jig. (If multiple ID change jigs can be not be made available, substitute with the method given later in this document.)

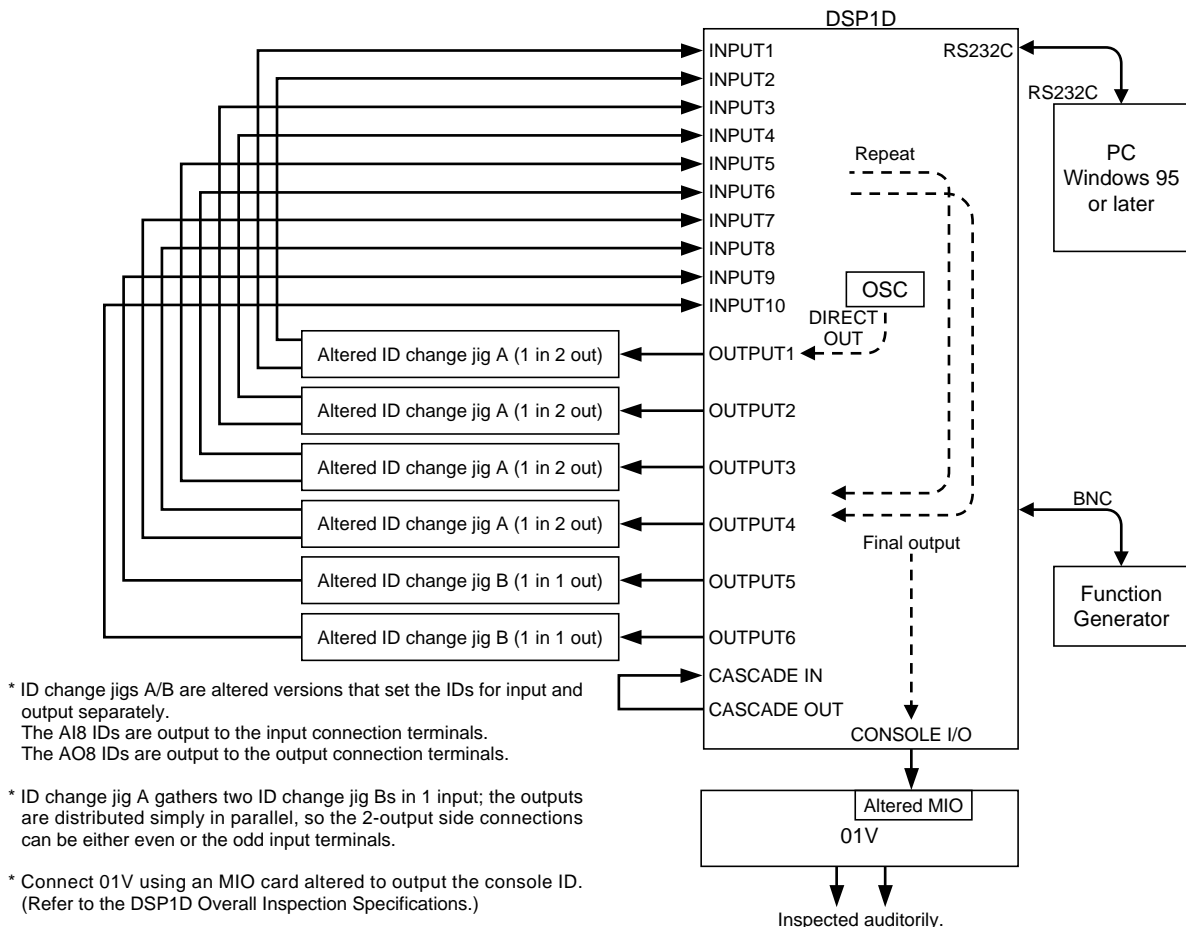

•Method using six altered ID change jigs (This is the method normally used.)

1. Connect according to the connection diagram. Supply a 48kHz clock from the function generator.
2. Execute the PM1D Manager for Windows from the PC. From Utility - LOAD/SAVE, execute the DSP1D sound and LOAD the inspection data. (For the version, installation method, usage method, etc., see below.)

Software used: PM1D Manager for Windows within PM1D system software
 Version used: PM1D system software component files with the version number listed on the cover sheet.
 (Managed with the already drawn CD-R assembly drawing (3JL-XY714A0.)
 * The installation method is the same. Refer to install.txt in the PM1D system software.

Data used: DSP1D sound inspection software within PM1D system software
 Version used: PM1D system software component files with the version number listed on the cover sheet.
 (Managed with the already drawn CD-R assembly drawing (3JL-XY714A0.)
 * Start the installed PM1D Manager for Windows, then read with UTILITY - LOAD/SAVE.

3. Set ENGINE A to W.CLOCK IN with SYS/W.CLOCK - WORD CLOCK.
4. Set OSC OUT to 1A08:1-1 with MON/CUE - OSCILLATOR, set ON. OSC to IN, then adjust the level.
5. Recall SCENE 00.1: SOUND THRU1 with SCENE - MEMORY.
6. Set the switch for the altered MIO connected to 01V to ST.
7. Check the audio through 01V.
8. Set the switch for the altered MIO connected to 01V to ST.
9. Check the audio through 01V.

•Method using only one altered ID change jig

1. Connect according to the connection diagram. Supply a 48kHz clock from the function generator.
2. Connect an altered ID change jig to INPUT 1 and 2 and OUTPUT 1.
3. Execute the PM1D Manager for Windows from the PC. From Utility - LOAD/SAVE, execute the DSP1D sound and LOAD the inspection data. (For the version, installation method, usage method, etc., see the previous page.)
4. Set ENGINE A to W.CLOCK IN with SYS/W.CLOCK - WORD CLOCK.
5. Set OSC OUT to 1A08:1-1 with MON/CUE - OSCILLATOR, set ON. OSC to IN, then adjust the level.
6. Recall SCENE 00.1: SOUND THRU1 with SCENE - MEMORY.
- *1 { 7. Set the switch for the altered MIO to ST and check the audio through 01V.
8. Set the switch for the altered MIO to MON and check the audio through 01V.
9. Recall SCENE 00.2: SOUND THRU2 with SCENE - MEMORY. Check that the audio goes off.
10. Change the input side connections only to INPUT 3 and 4.
11. Repeat *1.
12. Recall SCENE 00.3: SOUND THRU3 with SCENE - MEMORY. Check that the audio goes off.
13. Change the input side connections only to INPUT 5 and 6.
14. Repeat *1.
15. Recall SCENE 00.4: SOUND THRU4 with SCENE - MEMORY. Check that the audio goes off.
16. Change the input side connections only to INPUT 7 and 8.
17. Repeat *1.
18. Recall SCENE 00.5: SOUND THRU5 with SCENE - MEMORY. Check that the audio goes off.
19. Change the input side connections only to INPUT 9 and 10.
20. Repeat *1.
21. Set OSC OUT to 2A08:1-1.
22. Change the output side connection only to OUTPUT 2. (The INPUT remains 9 and 10 and the scene 00.5.)
23. Repeat *1.
24. Set OSC OUT to 3A08:1-1.
25. Change the output side connection only to OUTPUT 3.
26. Repeat *1.
27. Set OSC OUT to 4A08:1-1.
28. Change the output side connection only to OUTPUT 4.
29. Repeat *1.
30. Set OSC OUT to 5A08:1-1.
31. Change the output side connection only to OUTPUT 5.
32. Repeat *1.

- 33. Set OSC OUT to 6A08:1-1.
- 34. Change the output side connection only to OUTPUT 3.
- 35. Repeat *1.

1. DSP1D-CIB Test

This test checks the DSP1D-CIB. It checks the following items. Those items for which there are figures display the results in binary. Detailed screen output specifications are given on the following pages.

The details for 1-2. are omitted because they are the same as for 1-1.

* For the DPM (dual port RAM) item, EM BUS <-> TC BUS R etc. is written. This indicates which of the DPM buses is inspected. For example, for EM BUS <-> TC BUS R, this indicates the check of the TC BUS side seen from the DPM (right side for the DPS BUS <-> CM BUS notation).

1-1. DSP1D-CIB (TCU-IC129) Test

This test checks around the CIB TCU.

Check item

- ID TCU [11h]
- RAM
 - Data Bus 16bit(15-0)
 - Address Bus 20bit(19-0)
- Flash (Check Sum)
- Version
- DPM
 - EM BUS<->TC BUS R

1-2. DSP1D-CIB (TCU-IC129) Test

This test checks around the CIB HIF.

Check item

- ID TCU [12h]
- RAM
 - Data Bus 16bit(15-0)
 - Address Bus 20bit(19-0)
- Flash (Check Sum)
- Version
- DPM
 - HI BUS<->EM BUS L

1-3. DSP1D-CIB (ETC)Test

This test makes other checks of the CIB.

Check item

- FPGA HIF [02h]
- DPM
 - EMU<->CONS L
- FIFO
- TC IC

1-1. DSP1D-CIB (TCU) Test

This test checks around the CIB TCU.

OK/NG display for the page as a whole
Displayed when all the checks have been completed.

Received ID displayed as board name and hexadecimal

Checked in order from top to bottom. Completed main items have marks next to them.

Current status display

Stopped the moment an actual ID NG appears; stopped at the end of the page for any other NG.

Corresponding pin number

Corresponding IC number

Abnormal port name

Previously read value. [] gives the correct value. 4-digit hexadecimal notation

Terminal status display
Delimited in units of 8 digits right justified in the order upper then lower.
0: Normal 1: Abnormal -: Ignored

Now Checking ...

1-1. DSP1D-CIB (TCU-IC129) Test OK

- * ID TCU [11h] OK
- * RAM OK
 - DataBus Sub-item OK
 - AddressBus OK
- * Flash OK
- * Version OK
- * DPM Main item OK
 - EM BUS <-> TC BUS R OK

OK/NG display for individual items
The NG is displayed the moment the item is found to be NG, even if the test is still underway. If there is no response from the firmware, "NO" is displayed.

If OK, sub-items are not displayed.

1-1. DSP1D-CIB (TCU-IC129) Test

- * ID xxx [xxh] NG
- * RAM NG
 - DataBus NG
 - AddressBus NG
- * Flash NG
- * Version NG
- * DPM NG
 - EM BUS <-> TC BUS R NG

Flash(IC132):
Checksum = xxxx[xxxx]
Version:
Current = x.xx , Latest = x.xx

EM BUS <-> TC BUS R:
11111111 11111111
11111111 11111111

SRAM	OK: LED lit up
	NG: LED flashes on (0.2 s) - Off (0.2 s) - On (0.2 s) - Off (0.1 s)
Flash	OK: LED lit up
	NG: LED flashes on (0.1 s) - Off (0.1 s) - On (0.1 s) - Off (0.1 s)

1-3. DSP1D-CIB (ETC) Test

This test checks around the CIB ETC.

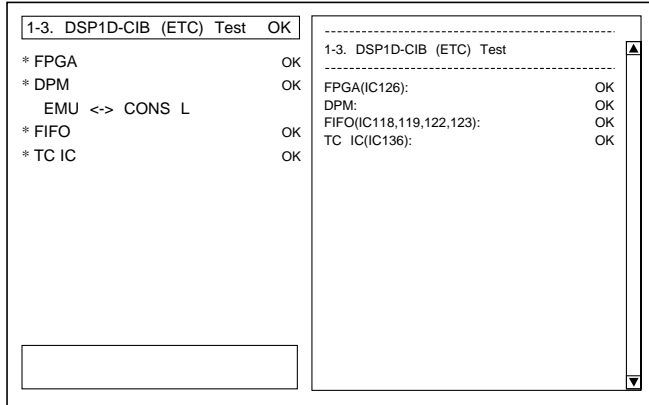

NG example

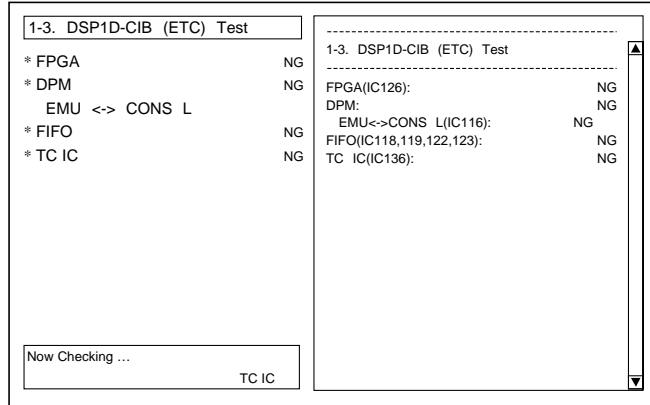

(**SRAM** OK: LED lit up
NG: LED flashes on (0.2 s) - Off (0.2 s) - On (0.2 s) - Off (0.1 s)
Flash OK: LED lit up
NG: LED flashes on (0.1 s) - Off (0.1 s) - On (0.1 s) - Off (0.1 s))

2. DSP1D-EMB Test

This test checks the EMB. It checks the following items. Those items for which there are figures display the results in binary. Detailed screen output specifications are given on the following pages.

The battery check item is only for 2-1. Here the voltage is checked and if it is within the correct range, OK is displayed. If it is NG, how far it deviates from the correct value is displayed.

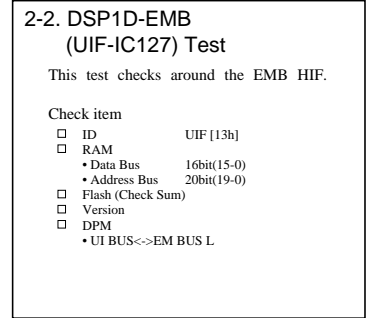
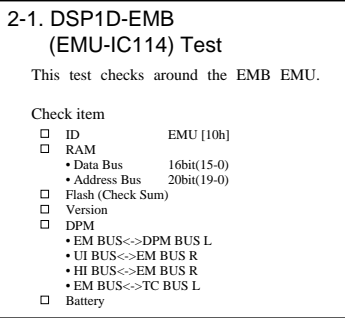

3. DSP1D-IFC (TCU) Test

This test checks the IFC board.

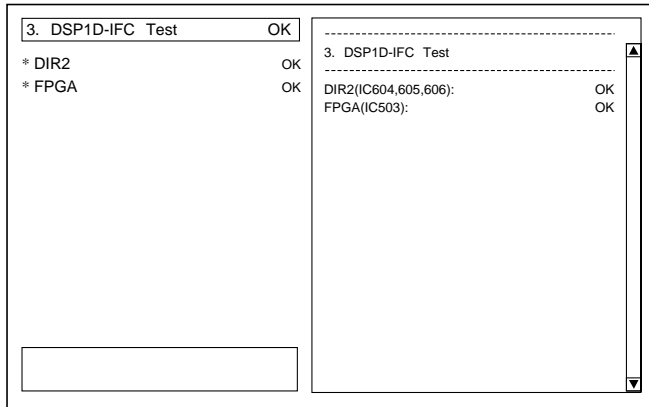

NG example

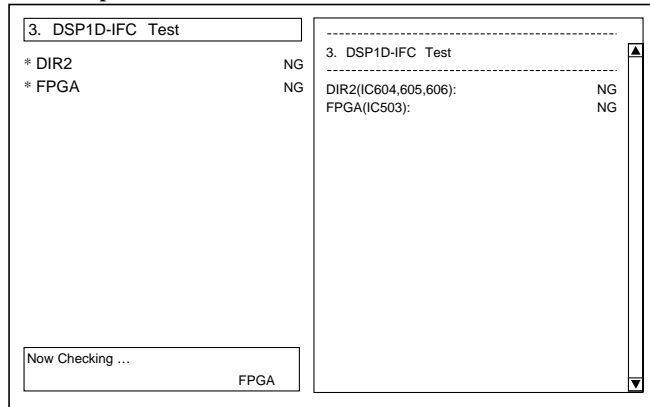

4. DSP1D-PDB Test

This test checks the DSP1D-PDB. It checks the following items. Those items for which there are figures display the results in binary. Detailed screen output specifications are given on the following pages.

DSP6 total count 9
DSP5 total count 11

4-1. DSP1D-PDB (CPU-IC101) Test
 This test checks around the PDB CPU.

Check item

- ID PDB [14h]
- RAM
 - Data Bus 16bit(15-0)
 - Address Bus 16bit(16-1)
- Flash (Check Sum)
- Version
- DPM
 - Data Bus 16bit(15-0)
 - Address Bus 15bit(15-1)

4-2. DSP1D-PDB (DSP6) Test
 This test checks around PDB DSP6.

Check item

- Chip Select
- DSP6 <-> CPU
 - Data Bus 16bit(15-0)
 - Address Bus 7bit(7-1)
- DSP6 <-> DRAM
 - Data Bus 32bit(31-0)
 - Address Bus 10bit(9-0)
- DSP6 -> DSP6
 - Serial I/O

4-3. DSP1D-PDB (DSP5) Test
 This test checks around PDB DSP5.

Check item

- Chip Select
- DSP5 <-> CPU
 - Data Bus 16bit(15-0)
 - Address Bus
- DSP6 -> DSP5
 - Serial I/O
- DSP5 -> DSP6
 - Serial I/O
- DPM
 - Serial I/O
 - Parallel I/O 32bit(31-0)

4-1. DSP1D-PDB (CPU-IC101) Test

This test checks around the PDB CPU.

4-1. DSP1D-PDB (CPU-IC101) Test OK

```

* ID      PDB [14h]      OK
* RAM      OK
  DataBus
  AddressBus
* Flash    OK
* Version  OK
* DPM
  DataBus  00000000 00000000
  AddressBus 00000000 00000000
    
```

4-1. DSP1D-PDB (CPU-IC101) Test

```

ID:      PDB [14h]      OK
RAM(IC107):
Flash(IC114):
Version:
DPM:
    
```

NG example

4-1. DSP1D-PDB (CPU-IC101) Test

```

* ID      xxx [xxh]      NG
* RAM      NG
  DataBus
  AddressBus
* Flash    NG
* Version  NG
* DPM
  DataBus  11111111 11111111
  AddressBus 11111111 11111111
    
```

4-1. DSP1D-PDB (CPU-IC101) Test

```

ID:      xxx [xxh]      NG
RAM(IC107):
DBus[xx-xx,xx-xx pin]
ABus[xx-xx,xx-xx pin]
Flash(IC114):
CheckSum = xxxx [xxxx]
Version:
Current = x.xx , Latest = x.xx
DPM:
    
```

Now Checking ... Version

(SRAM OK: LED lit up
 NG: LED flashes on (0.2 s) - Off (0.2 s) - On (0.2 s) - Off (0.1 s)
 Flash OK: LED lit up
 NG: LED flashes on (0.1 s) - Off (0.1 s) - On (0.1 s) - Off (0.1 s))

4-2. DSP1D-PDB (DSP6) Test

This test checks around PDB DSP6.

The DSP check results are displayed for each DSP. The DSPs are displayed in order from the right of the ChipSelect signals on the circuit diagram. (Blank: Not yet checked; 0: Normal; 1: Abnormal; N: No response)

Stopped the moment an actual Chip Select or TxB NG appears; stopped at the end of the page for any other NG.

4-2. DSP1D-PDB (DSP6) Test OK

```

* ChipSelect 0 00000000 OK
* DSP6 <-> CPU OK
  DataBus 0 00000000
  AddressBus 0 00000000
* DSP6 <-> DRAM OK
  DataBus 0 00000000
  AddressBus 0 00000000
* DSP6 <-> DSP6 OK
  Serial I/O xxx/xxx
    
```

4-2. DSP1D-PDB (DSP6) Test

```

ChipSelect:
DSP6<->CPU:
DSP6<->DRAM:
DSP6 -> DSP6:
    
```

NG example

4-2. DSP1D-PDB (DSP6) Test

```

* ChipSelect 0 00100000 NG
* DSP6 <-> CPU NG
  DataBus 0 00101000
  AddressBus 0 00001000
* DSP6 <-> DRAM NG
  DataBus 0 00000100
  AddressBus 0 00000100
* DSP6 <-> DSP6 NG
  Serial I/O xxx/xxx
    
```

4-2. DSP1D-PDB (DSP6) Test

```

ChipSelect:
DSP6<->CPU:
DBus[34-43,47-52 pin]
ICxxx
DSP6<->DRAM:
ICxxx 11111111 11111111
ICxxx 11111111 11111111
ABus[25-31 pin]
ICxxx 11111111
DSP6<->DRAM:
DBus[151-144,142-135,130-123,121-114pin]
ICxxx - ICxxx 11111111 11111111
- ICxxx 11111111 11111111
ABus[163-154 pin]
ICxxx - ICxxx, ICxxx 11 11111111
DSP6 -> DSP6:
SI/SO
ICxxx[SOx] - ICxxx[SIx]
    
```

Now Checking ... DSP6 -> DSP6 No. xxx

Display when a number of checks are complete and there have been a number of NGs

IC number display for both upper and lower

Displays from which SO to which SI is NG.

Gives the abnormal DSP IC number.

Displayed in binary in the order Upper: 16 bits, Lower: 16 bits The corresponding DRAM IC number is also displayed.

4-3. DSP1D-PDB (DSP5) Test

This test checks around PDB DSP6.

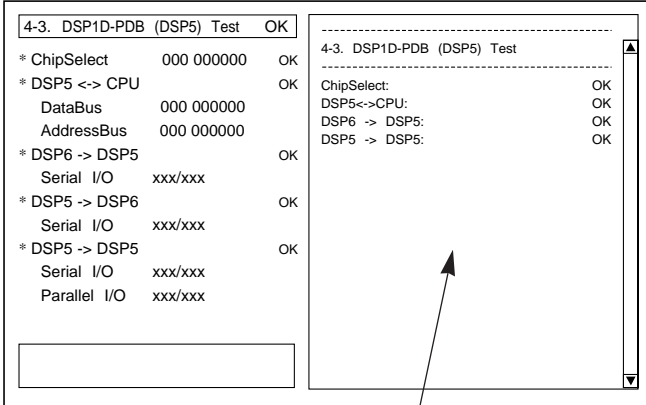

Basically, the same as up till here

NG example

For the DSP5 address bus, only the upper bits can be checked.

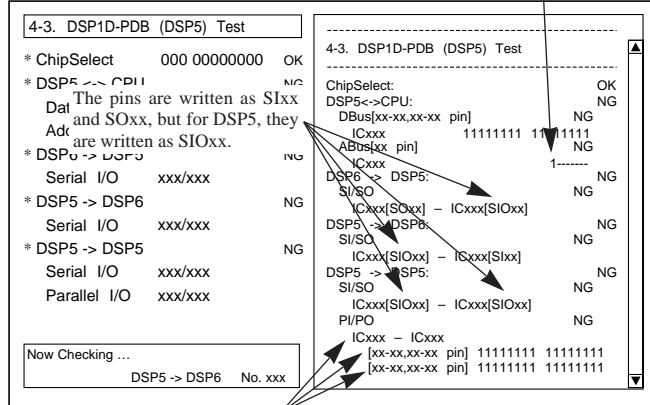

Displays which pin numbers are NG between which DSPs. 16 are displayed at a time. The display is three digits, including the IC number display.

5. DSP1D-GDB Test

This test checks the GDB. It checks the following items. The specifications are basically the same as for 4-1. through 4-3.

- DSP6 total count 13
- DSP5 total count 7

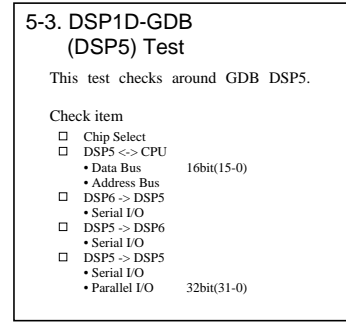
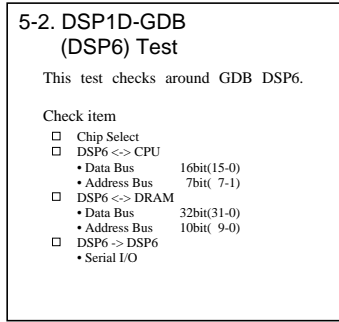
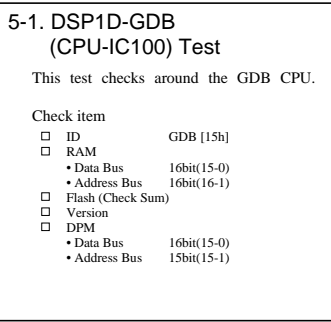

6. DSP1D-IDB1 Test

This test checks the IDB1. It checks the following items. The specifications are basically the same as for 4-1. through 4-3.

- DSP6 total count 16
- DSP5 total count 8

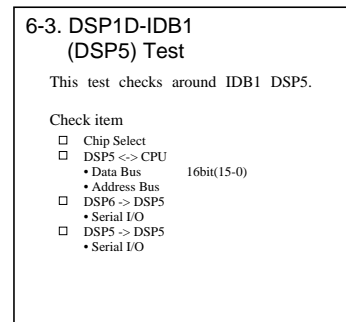
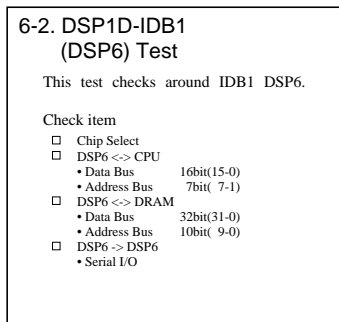
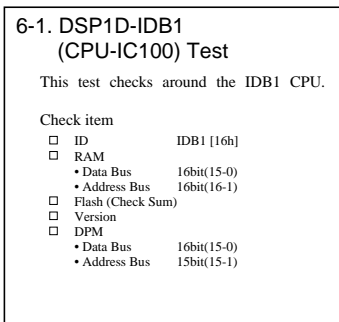

7. DSP1D-IDB2 Test

This test checks the IDB2. It checks the following items. The specifications are basically the same as for 4-1. through 4-3.

DSP6 total count 16

DSP5 total count 8

7-1. DSP1D-IDB2 (CPU-IC100) Test

This test checks around the IDB2 CPU.

Check item

- ID IDB2 [16h]
- RAM
 - Data Bus 16bit(15-0)
 - Address Bus 16bit(16-1)
- Flash (Check Sum)
- Version
- DPM
 - Data Bus 16bit(15-0)
 - Address Bus 15bit(15-1)

7-2. DSP1D-IDB2 (DSP6) Test

This test checks around IDB2 DSP6.

Check item

- Chip Select
- DSP6 <-> CPU
 - Data Bus 16bit(15-0)
 - Address Bus 7bit(7-1)
- DSP6 <-> DRAM
 - Data Bus 32bit(31-0)
 - Address Bus 10bit(9-0)
- DSP6 -> DSP6
 - Serial I/O

7-3. DSP1D-IDB2 (DSP5) Test

This test checks around IDB2 DSP5.

Check item

- Chip Select
- DSP5 <-> CPU
 - Data Bus 16bit(15-0)
 - Address Bus
- DSP6 -> DSP5
 - Serial I/O
- DSP5 -> DSP5
 - Serial I/O

8. DSP1D-EDB Test

This test checks the EDB. It checks the following items. The specifications are basically the same as for 4-1. through 4-2.

DSP6 total count 12

2-1. DSP1D-EMB (EMU-IC114) Test

This test checks around the EMB EMU.

Check item

- ID EMU [10h]
- RAM
 - Data Bus 16bit(15-0)
 - Address Bus 20bit(19-0)
- Flash (Check Sum)
- Version
- DPM
 - EM BUS<->DPM BUS L
 - UI BUS<->EM BUS R
 - HI BUS<->EM BUS R
 - EM BUS<->TC BUS L
- Battery

2-2. DSP1D-EMB (UIF-IC127) Test

This test checks around the EMB HIF.

Check item

- ID UIF [13h]
- RAM
 - Data Bus 16bit(15-0)
 - Address Bus 20bit(19-0)
- Flash (Check Sum)
- Version
- DPM
 - UI BUS<->EM BUS L

9. DSP1D Connection Test

This test checks the connections among the PDB, GDB, IDB1, IDB2, and EDB. It checks the following items. Detailed screen output specifications are given on the following pages.

* There are duplicate checks, but for checking just specific boards, these checks are not omitted.

9-1. DSP1D-Connection (PDB) Test

Checks the connections between the PDB and the other boards.

Check item

- PDB -> IDB1
- PDB -> IDB2
- PDB -> GDB
- PDB -> EDB
- IDB1 -> PDB
- IDB2 -> PDB
- GDB -> PDB
- EDB -> PDB

9-2. DSP1D-Connection (GDB) Test

Checks the connections between the GDB and the other boards.

Check item

- GDB -> PDB
- IDB1 -> GDB
- IDB2 -> GDB
- PDB -> GDB
- EDB -> GDB

9-3. DSP1D-Connection (IDB1) Test

Checks the connections between the IDB1 and the other boards.

Check item

- IDB1 -> GDB
- IDB1 -> PDB
- IDB1 -> IDB2
- PDB->IDB1

9-4. DSP1D-Connection (IDB2) Test

Checks the connections between the IDB2 and the other boards.

Check item

- IDB2 -> GDB
- IDB2 -> PDB
- IDB1 -> IDB2
- PDB->IDB2

9-5. DSP1D-Connection (EDB) Test

Checks the connections between the EDB and the other boards.

Check item

- EDB -> GDB
- EDB -> PDB
- PDB -> EDB

9-1. DSP1D-Connection (PDB) Test

Checks the connections between the PDB and the other boards.

9-1. DSP1D-Connection (PDB) Test OK		
* PDB -> IDB1 xxx/xxx	OK	
* PDB -> IDB2 xxx/xxx	OK	
* PDB -> GDB xxx/xxx	OK	
* PDB -> EDB xxx/xxx	OK	
* IDB1 -> PDB xxx/xxx	OK	
* IDB2 -> PDB xxx/xxx	OK	
* GDB -> PDB xxx/xxx	OK	
* EDB -> PDB xxx/xxx	OK	

9-1. DSP1D-Connection (PDB) Test		
PDB->IDB1:	OK	
PDB->IDB2:	OK	
PDB->GDB:	OK	
PDB->EDB:	OK	
IDB1->PDB:	OK	
IDB2->PDB:	OK	
GDB->PDB:	OK	
EDB->PDB:	OK	

Basically, the same as up till here

NG example

9-1. DSP1D-Connection (PDB) Test		
* PDB -> IDB1 xxx/xxx	NG	
* PDB -> IDB2 xxx/xxx	NG	
* PDB -> GDB xxx/xxx	NG	
* PDB -> EDB xxx/xxx	NG	
* IDB1 -> PDB xxx/xxx	NG	
* IDB2 -> PDB xxx/xxx	NG	
* GDB -> PDB xxx/xxx	NG	
* EDB -> PDB xxx/xxx	NG	

9-1. DSP1D-Connection (PDB) Test		
PDB->IDB1:	NG	
ICxxx[xxxxx] - ICxxx[xxxxx]		
ICxxx[xxxxx] - ICxxx[xxxxx]		
PDB->IDB2:	NG	
ICxxx[xxxxx] - ICxxx[xxxxx]		
PDB->GDB:	NG	
ICxxx[xxxxx] - ICxxx[xxxxx]		
PDB->EDB:	NG	
ICxxx[xxxxx] - ICxxx[xxxxx]		
IDB1->PDB:	NG	
ICxxx[xxxxx] - ICxxx[xxxxx]		
IDB2->PDB:	NG	
ICxxx[xxxxx] - ICxxx[xxxxx]		
GDB->PDB:	NG	
ICxxx[xxxxx] - ICxxx[xxxxx]		
EDB->PDB:	NG	
ICxxx[xxxxx] - ICxxx[xxxxx]		

Displays which pin numbers are NG between which ICs

10. DSP1D-JK1 (INPUT x) TEST

This test checks the JK1 board with loopback connections. These items are repeated for just the specified range of Inputs 1-10. The input ID change jig is used for Items 10 and 11.

10-1. DSP1D-JK1 (INPUT x) Test OK		
* DIR2	OK	
* SI	OK	
* RQ	OK	
* AK	OK	
* W.CLK	OK	
* CONTROL	OK	
* ID	OK	
In		
Out		
* MSB/LSB	OK	
* 2CH/4CH	OK	

Select [OUTPUTPort]. 1
 Select [INPUTPort] from 1
 Select [INPUTPort] to 10

Fixed to the port selected for the output side; the input connections are changed in order.

When changing to the next port, a pop-up box like the one below is displayed.

Connect [OUTPUT 1] to [INPUT 1].

NG example

10-1. DSP1D-JK1 (INPUT x) Test		
* DIR2	NG	
* SI	NG	
* RQ	NG	
* AK	NG	
* W.CLK	NG	
* CONTROL	NG	
* ID	NG	
In		
Out		
* MSB/LSB	NG	
* 2CH/4CH	NG	

10-1. DSP1D-JK1 (INPUT 1) Test		
DIR2(IC112):	NG	
SI:	NG	
RQ:	NG	
AK:	NG	
W.CLK:	NG	
CONTROL:	NG	
ID:		
In	NG	
Out	NG	
MSB/LSB:	NG	
2CH/4CH:	NG	

11. DSP1D-JK4 (TO CONSOLE x) Input Test

This test checks the JK4 port input direction communications. These items are repeated for the specified range of TO CONSOLE 1-2.

11-1. DSP1D-JK4 (TO CONSOLE 1) INPUT OK		
* DIR2	OK	
* SI	OK	
* W.CLK	OK	
* ID	OK	
In		
Out		
* MSB/LSB	OK	

Select [OUTPUT Port]. 1
 Select [TO CONSOLEPort] from 1
 Select [TO CONSOLEPort] to 2

Fixed to the port selected for the output side; the TO CONSOLE connections are changed in order.

When changing to the next port, a pop-up box like the one below is displayed.

Connect [OUTPUT 1] to [TO CONSOLE 1]

NG example

11-1. DSP1D-JK4 (TO CONSOLE 1) INPUT OK		
* DIR2	NG	
* SI	NG	
* W.CLK	NG	
* ID	NG	
In		
Out		
* MSB/LSB	NG	

11-1. DSP1D-JK4 (TO CONSOLE 1) INPUT Test		
DIR2(IC112):	NG	
SI:	NG	
W.CLK:	NG	
ID:		
In	NG	
Out	NG	
MSB/LSB:	NG	

12. DSP1D-JK2 (OUTPUT x) Test

This test checks the JK2 port with loopback connections. These items are repeated only for INPUT1-10. The output ID change jig is used for Item 12.

12-1. DSP1D-JK2 (OUTPUT 1) Test OK * SO ← OK * RQ OK * AK OK * W.CLK OK * CONTROL OK * ID OK In Out	The INPUT port used for the output check is selected from the pull-down list. <div style="border: 1px solid black; padding: 5px; margin: 5px;"> Select [INPUT Port]. 1 ▾ SO: 1 ▾ RQ: 1 ▾ AK: 10 ▾ W.C ID: [] ▾ In Out OK </div> Fixed to the port selected for the input side; the output connections are changed in order. When changing to the next port, a pop-up box like the one below is displayed. <div style="border: 1px solid black; padding: 5px; margin: 5px; width: fit-content; margin-left: auto;"> Connect [OUTPUT 1] to [INPUT 1]. OK </div>
---	---

ID change jig DIP switch settings →

NG example

12-1. DSP1D-JK2 (OUTPUT 1) Test OK * SO NG * RQ NG * AK NG * W.CLK NG * CONTROL NG * ID NG In Out	12-1. DSP1D-JK2 (OUTPUT 1) Test SO: NG RQ: NG AK: NG W.CLK: NG ID: NG In NG Out NG
---	---

Now Checking ... ID Out

13. DSP1D-JK4 (TO CONSOLE x) Output Test

This test checks the JK4 port output direction communications. For this item, use either the altered TO CONSOLE (OUTPUT) ID change jig or the altered special cable.

13-1. DSP1D-JK4 (TO CONSOLE 1) OUTPUT OK * SO ← OK	13-1. DSP1D-JK4 (TO CONSOLE 1) OUTPUT Test The Input port used for the TO CONSOLE check is selected from the pull-down list. (The port selected in Test 12 is displayed as the default. Normally, the input cable that has been connected and reconnected sequentially in 12. can just be reconnected to TO CONSOLE.) <div style="border: 1px solid black; padding: 5px; margin: 5px;"> Select [INPUT Port]. 1 ▾ Select [TO CONSOLE Port] from 1 ▾ Select [TO CONSOLE Port] to 2 ▾ OK </div> Fixed to the port selected for the input side; the TO CONSOLE connections are changed in order. When changing to the next port, a pop-up box like the one below is displayed. <div style="border: 1px solid black; padding: 5px; margin: 5px; width: fit-content; margin-left: auto;"> Connect [INPUT 1] to [TO CONSOLE 1]. OK </div>
---	---

For this item, the DIP switch setting does not matter, so it can be ignored →

NG example

13-1. DSP1D-JK4 (TO CONSOLE 1) OUTPUT * SO NG	13-1. DSP1D-JK4 (TO CONSOLE 1) OUTPUT Test SO: NG
--	--

Now Checking ... MSB/LSB

14. DSP1D-JK3 (CASCADE) Test

This test checks the JK3 port with loopback connections. For this test, use either the Cascade ID change jig.

14. DSP1D-JK3 (CASCADE) Test OK * DIR2 ← OK * SI/SO OK * W.CLK OK * CONTROL OK * ID (CASCADE IN) OK In Out * ID (CASCADE OUT) ← OK In Out * MSB/LSB OK	14. DSP1D-JK3 (CASCADE) Test DIR: A pop-up box is displayed asking you to change SI/S the connections and DIP switch settings. <div style="border: 1px solid black; padding: 5px; margin: 5px;"> Connect [INPUT 1] to [TO CONSOLE 1]. OK </div> The pop-up box below is displayed just before the ID (CASCADE out), so change the ID change jig DIP switch settings. <div style="border: 1px solid black; padding: 5px; margin: 5px; width: fit-content; margin-left: auto;"> Change DipSW. OK </div>
---	--

ID change jig DIP switch settings →

NG example

14. DSP1D-JK3 (CASCADE) Test * DIR2 NG * SI/SO NG * W.CLK NG * CONTROL NG * ID (CASCADE IN) NG In Out * ID (CASCADE OUT) NG In Out * MSB/LSB NG	14. DSP1D-JK3 (CASCADE) Test DIR2(IC110,126): NG SI/SO: NG * W.CLK: NG W.CLK: NG CONTROL: NG ID(CASCADE IN): NG In NG Out NG ID(CASCADE OUT): NG In NG Out NG MSB/LSB: NG
--	---

Now Checking ... MSB/LSB

15. DSP1D-JK5 Test

This test checks the JK5 port.

- Normal behavior for each inspection item
- REMOTE (CROSS) D24 playback (TC send)
- TC TC check from D24
- REMOTE (STRAIGHT) D24 stop

16. DSP1D-JK6 Test

This test checks the JK6 port and LED2. For details on how to change the connections, see Page 7.

■ ERROR MESSAGES

- **If both ENGINE ID A and B indicators are flash-ing:**

- There is a malfunction in the internal board (PDB, GDB, IDB1/2, EDB, EMB, or CIB). Or the necessary board does not exist.

- **If either ENGINE ID A or B indicator is flashing:**

- During the Mirror mode operation, the ENGINE ID indicator for the unused DSP1D/DSP1D-EX flashes, indicating that the unit is in standby mode.

- If Indicator A is flashing, unit A is in standby mode. If Indicator B is flashing, unit B is in standby mode.

- **If the CONTROL I/O 1 indicator is flashing:**

- Communication between the CS1D control surface and the DSP1D is not established. The CONSOLE 1, 2 IN OUT jacks or the PC CON-TROL port is not connected correctly.

- **If the INPUT CONFIGURATION 48CH is flashing:**

- The signal is not locking to the word clock.

BLOCK DIAGRAM

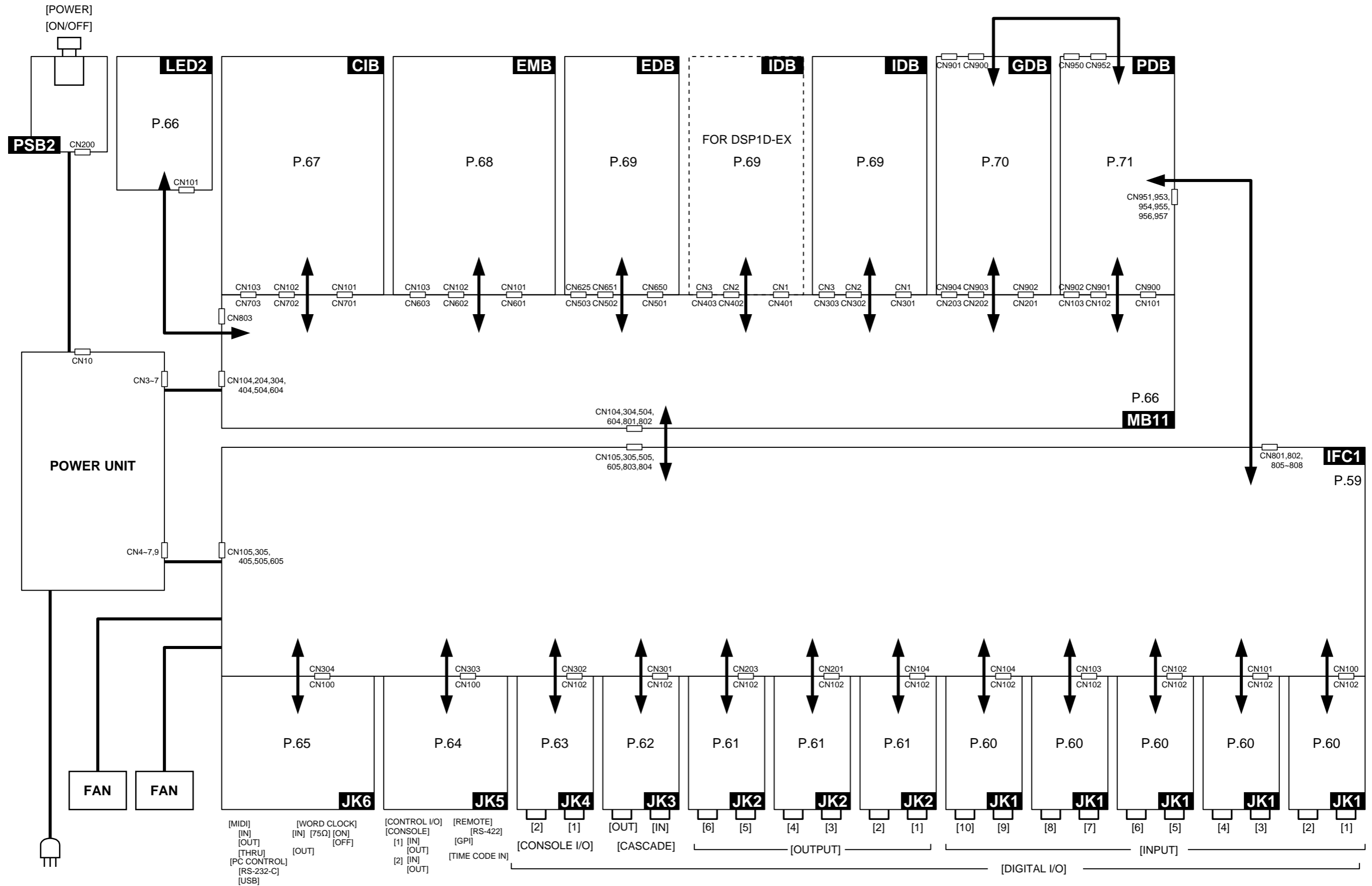

WHOLE

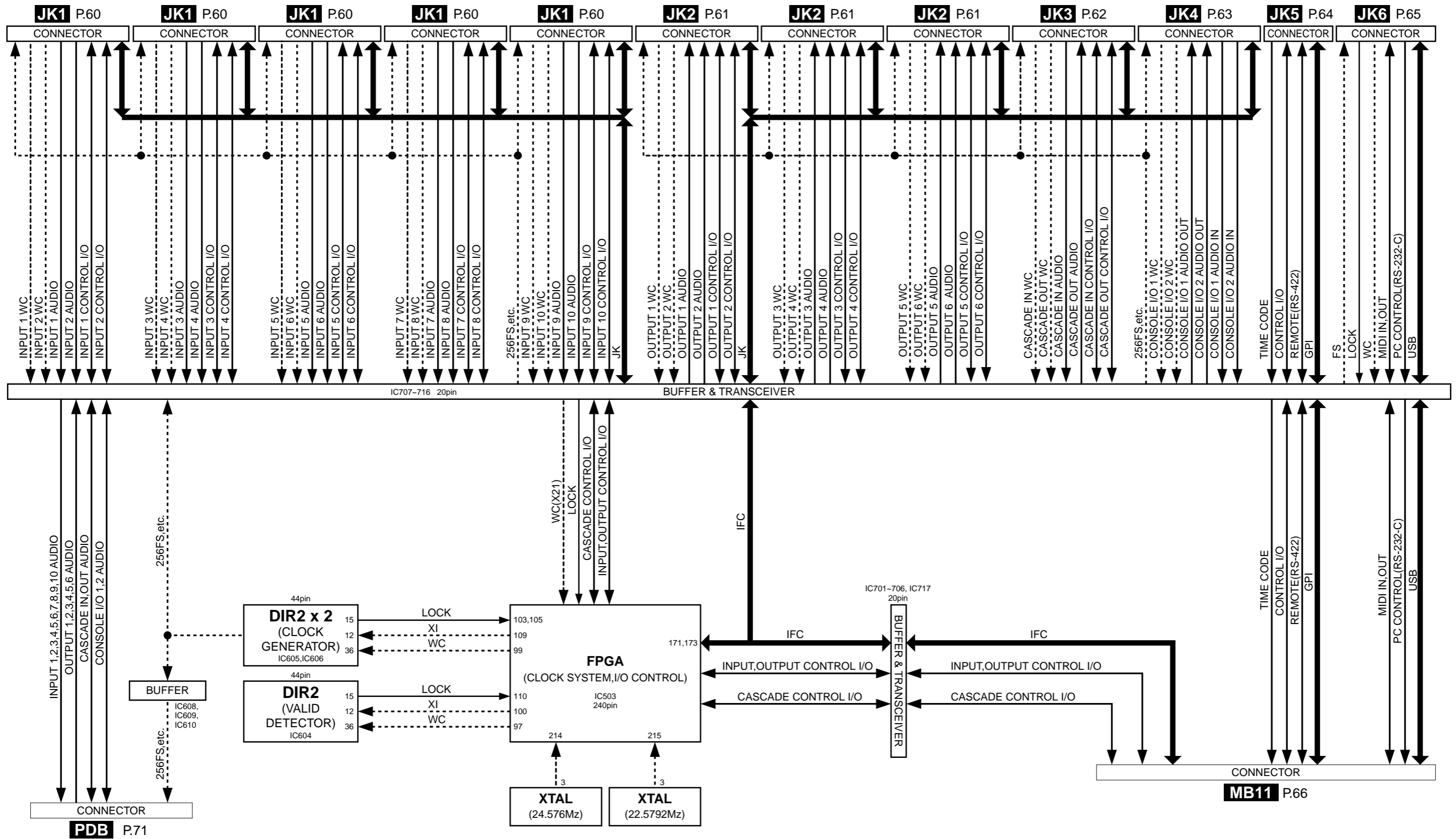

IFC1

IFC1 P.59

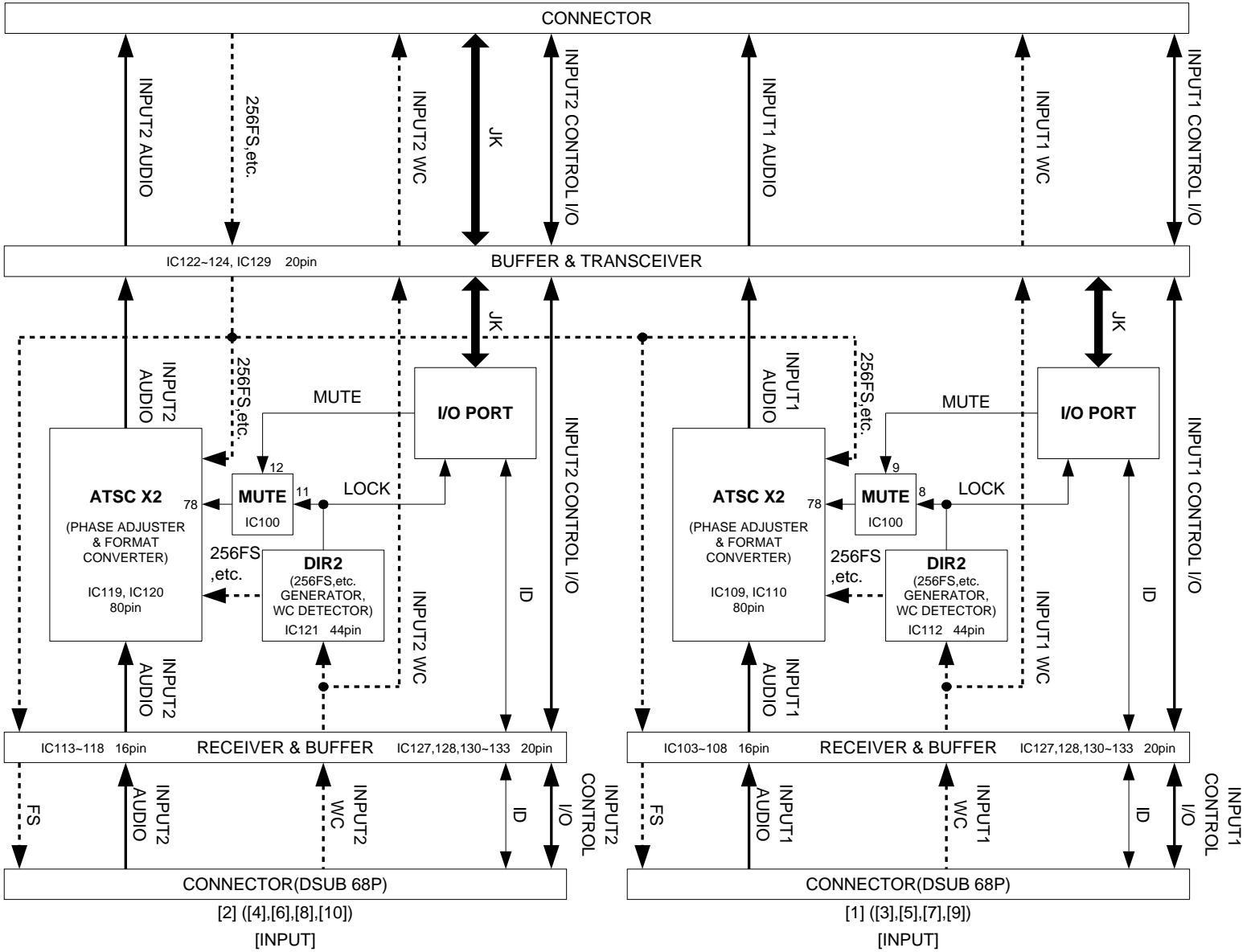

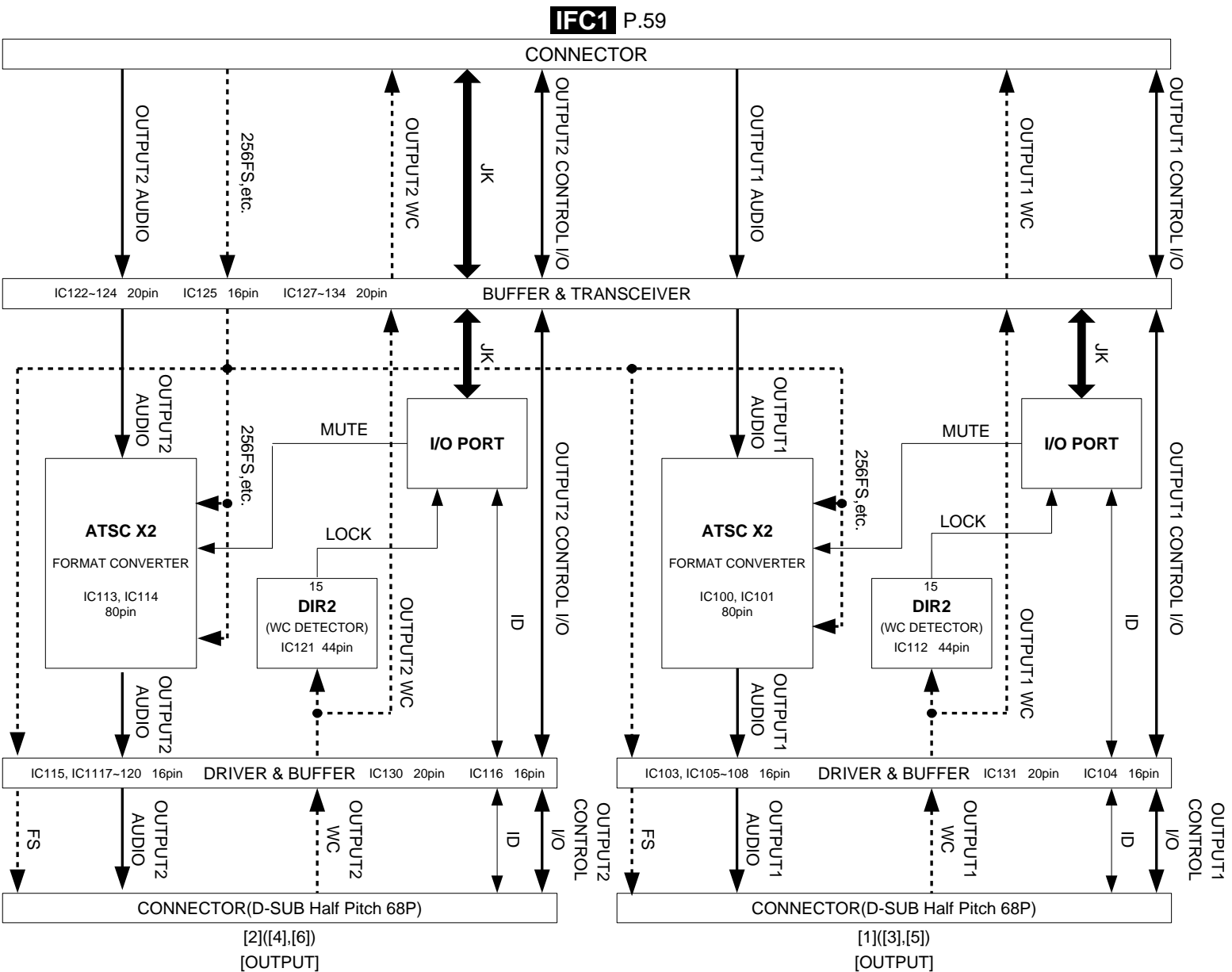

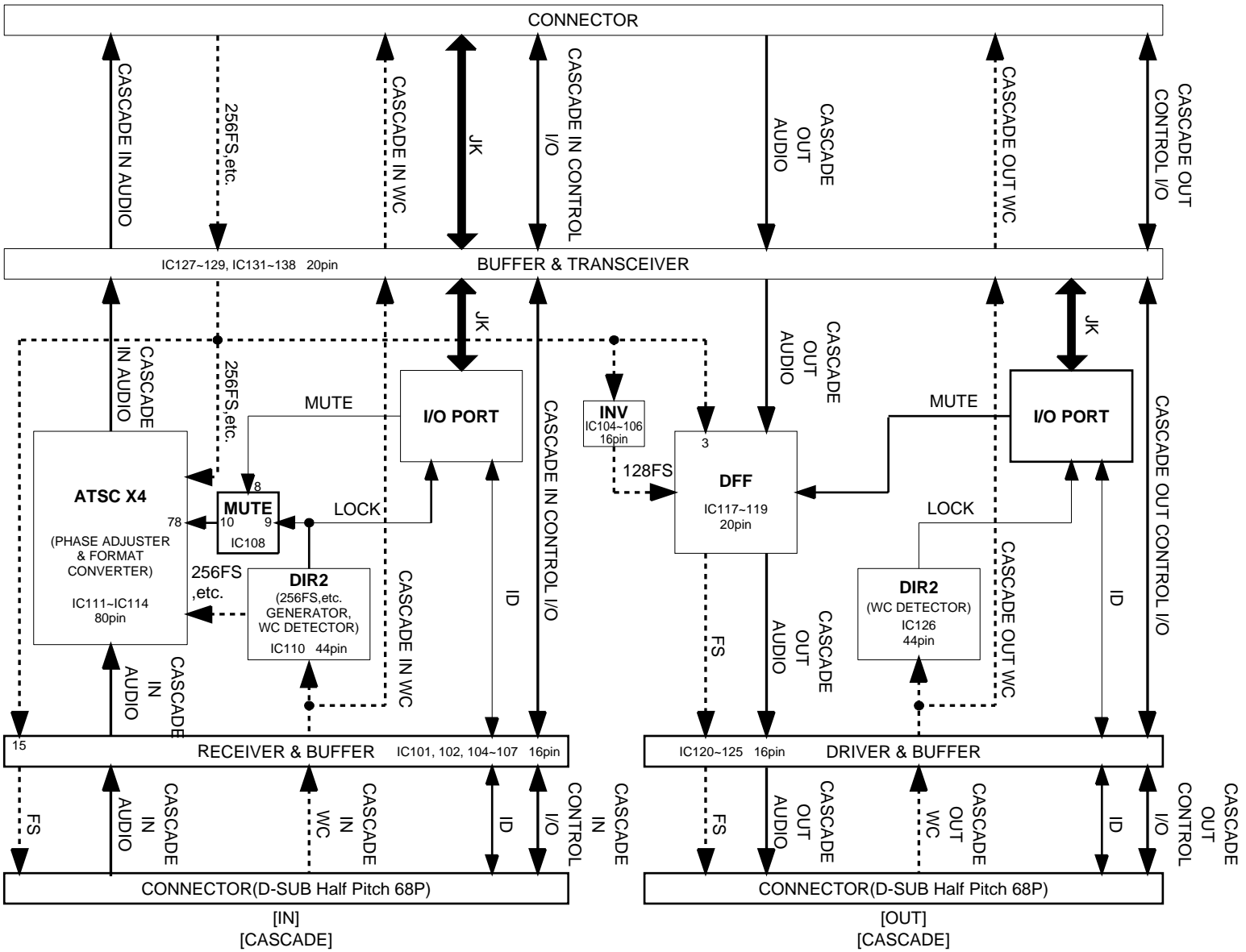

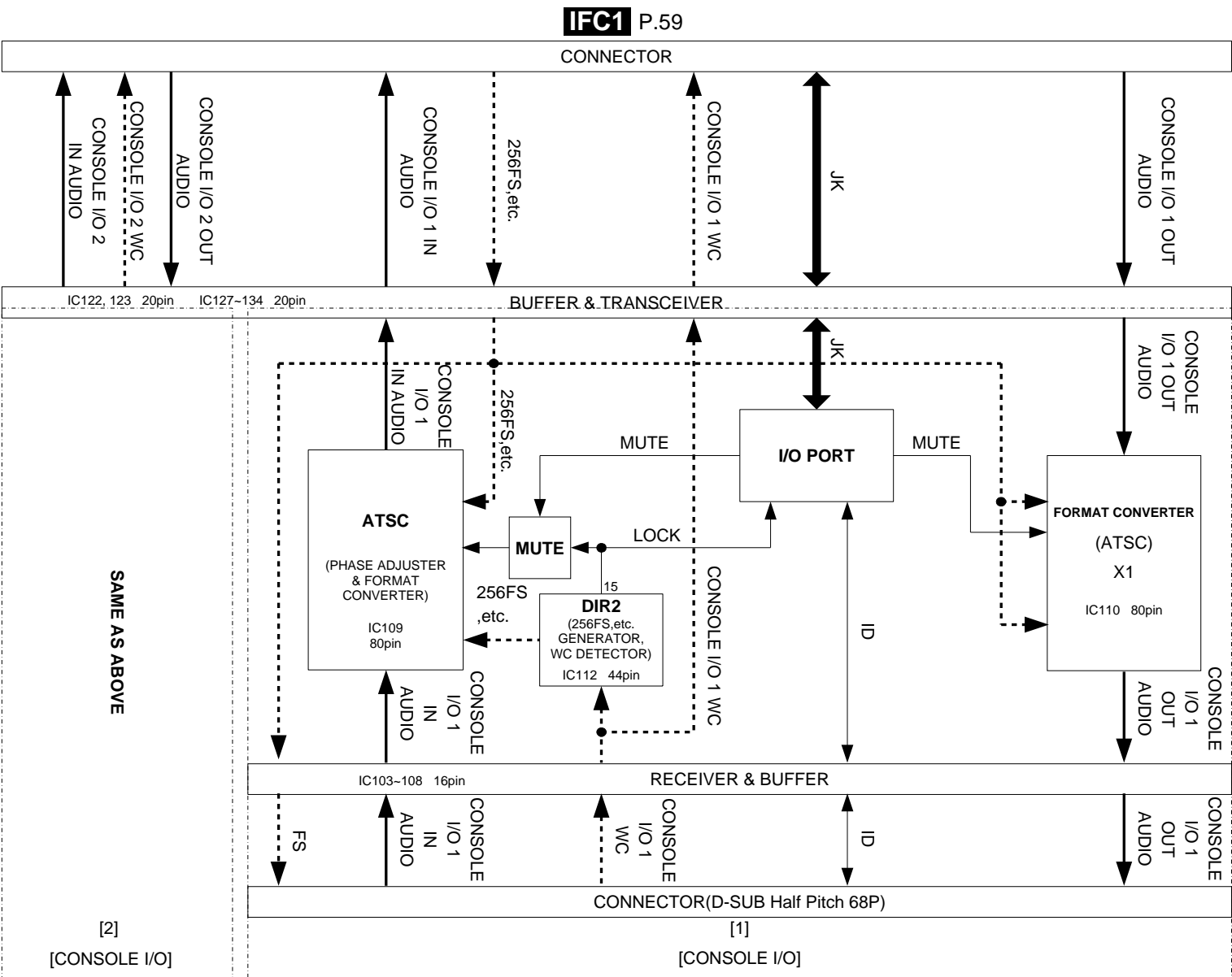

IFC1 P.59

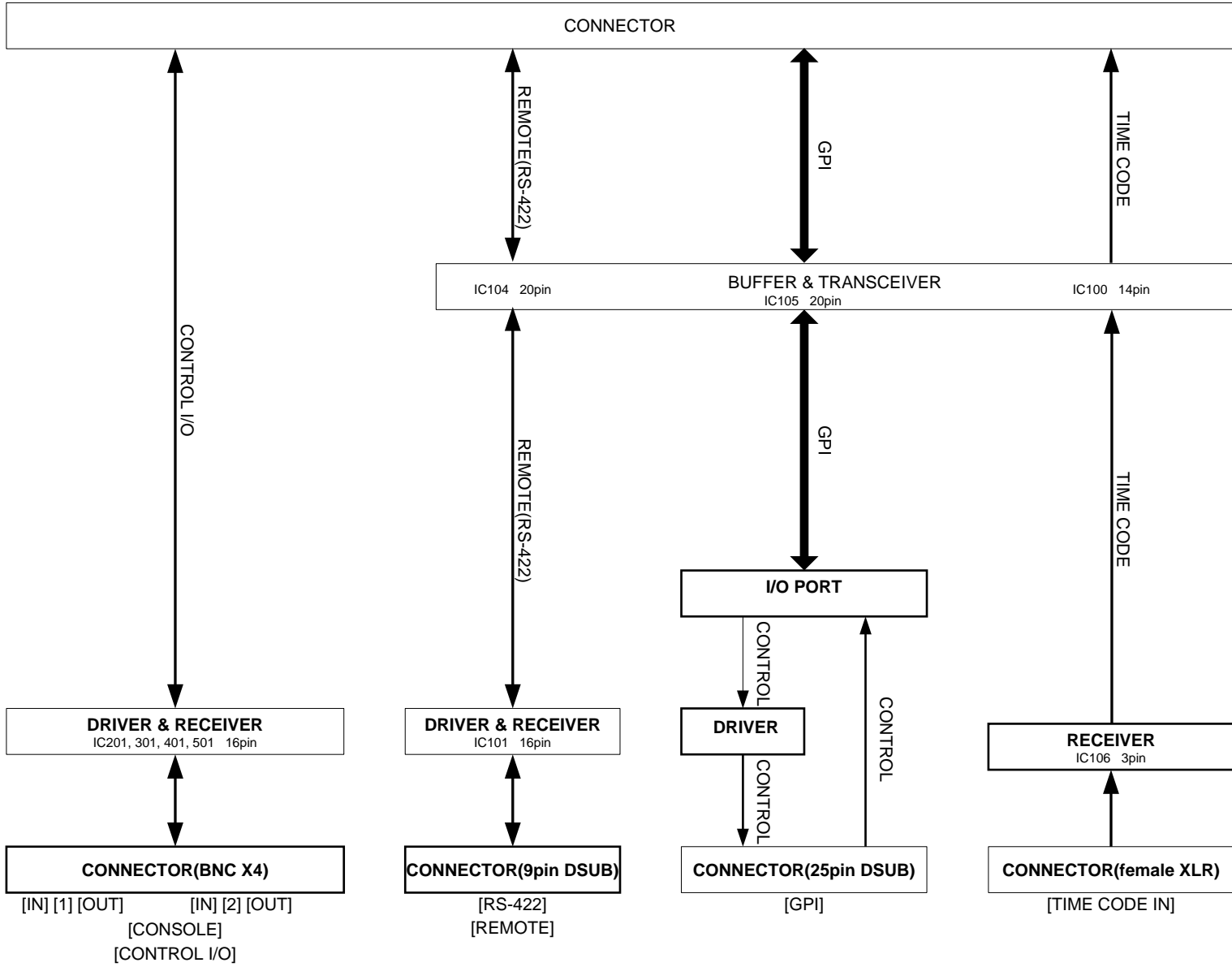

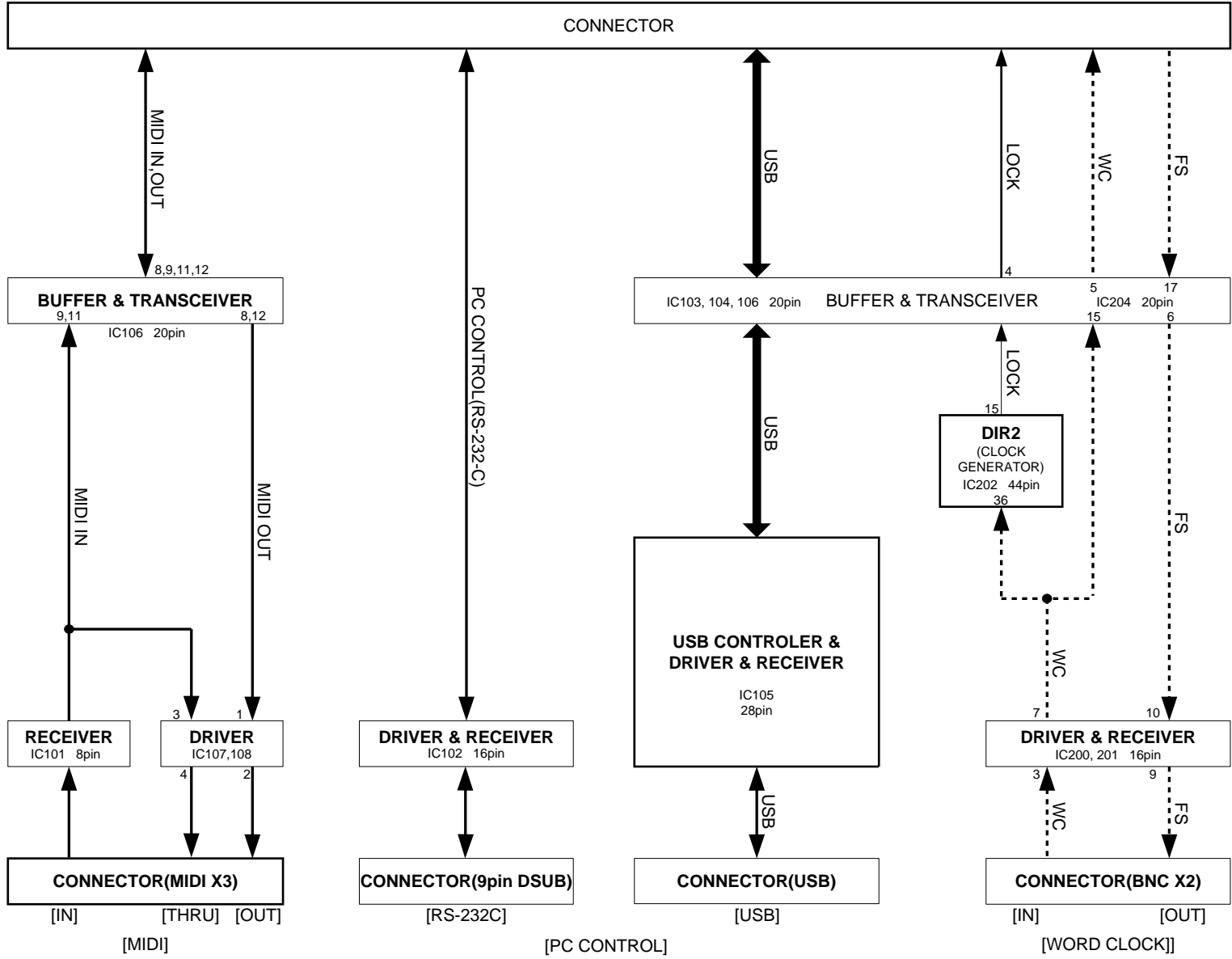

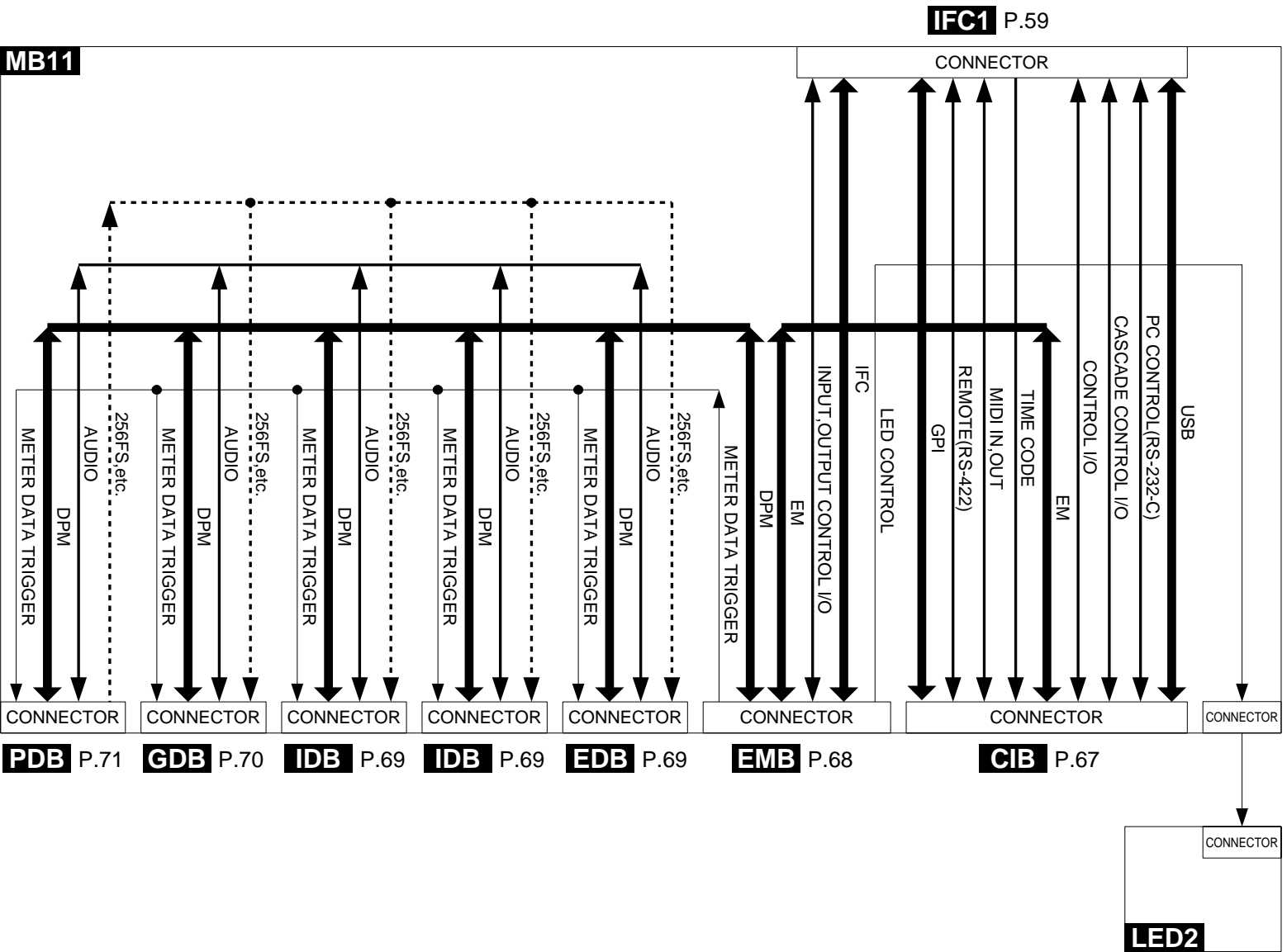

MB11 LED2

MB11 P.66

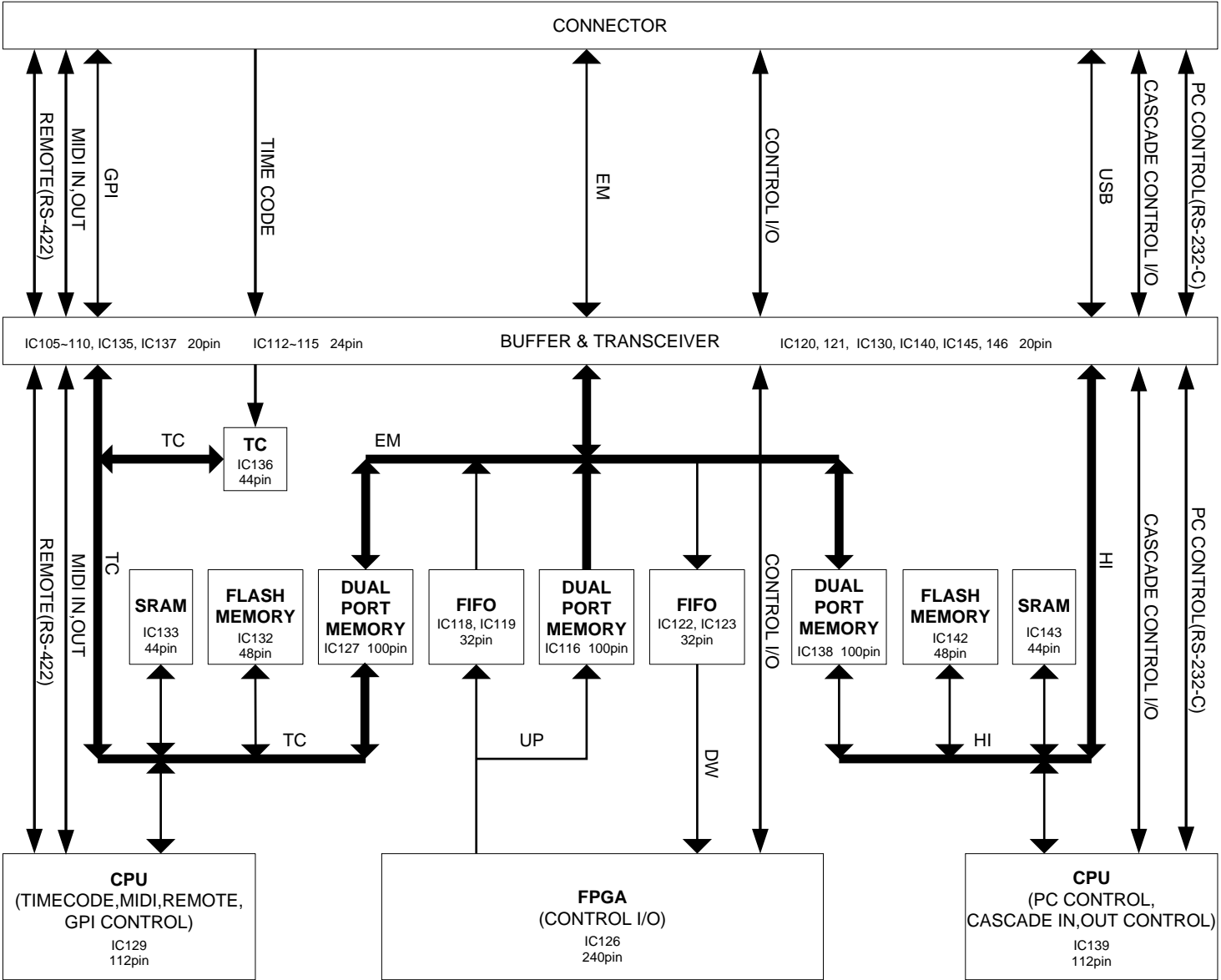

CIB

MB11 P.66

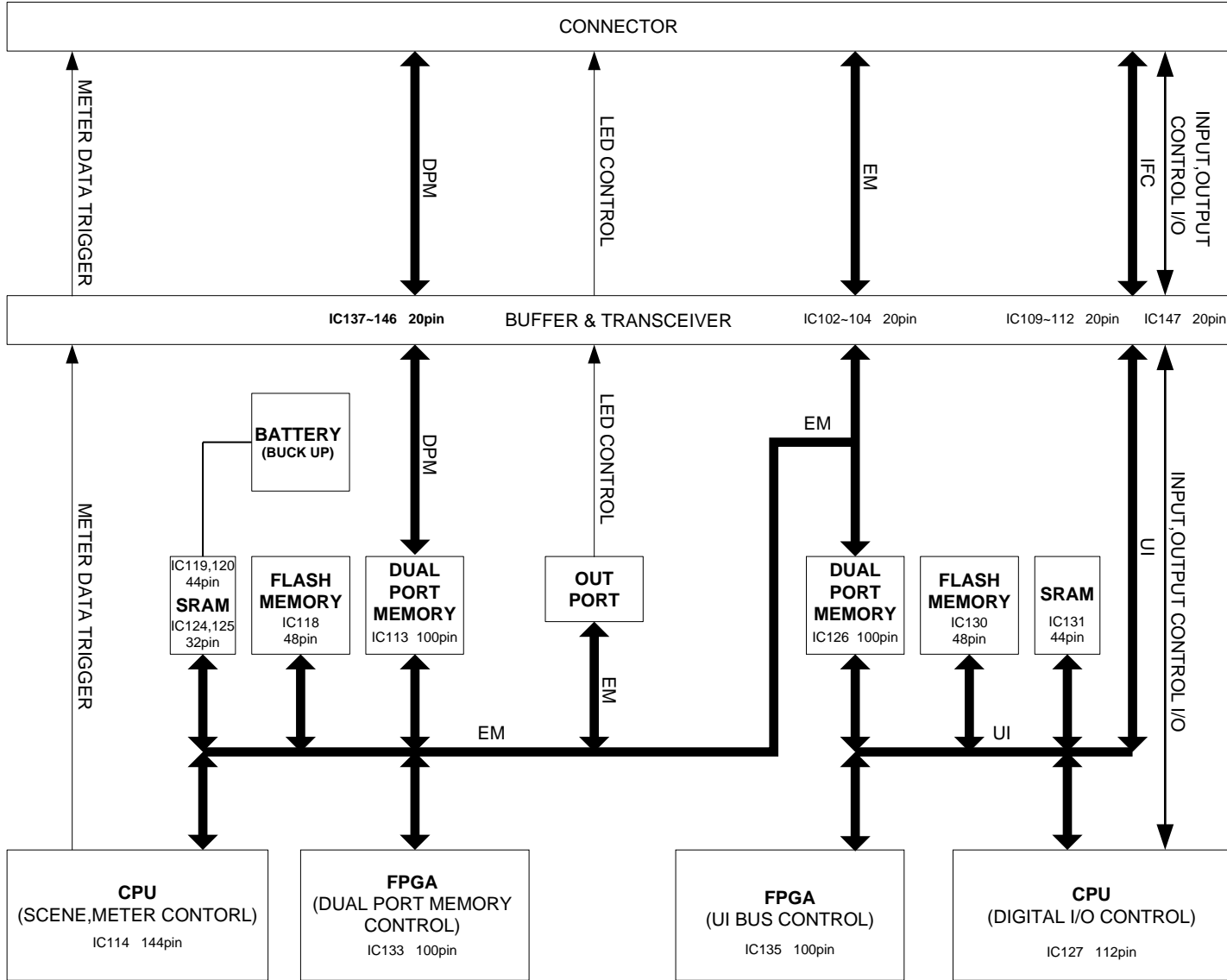

IDB **EDB**

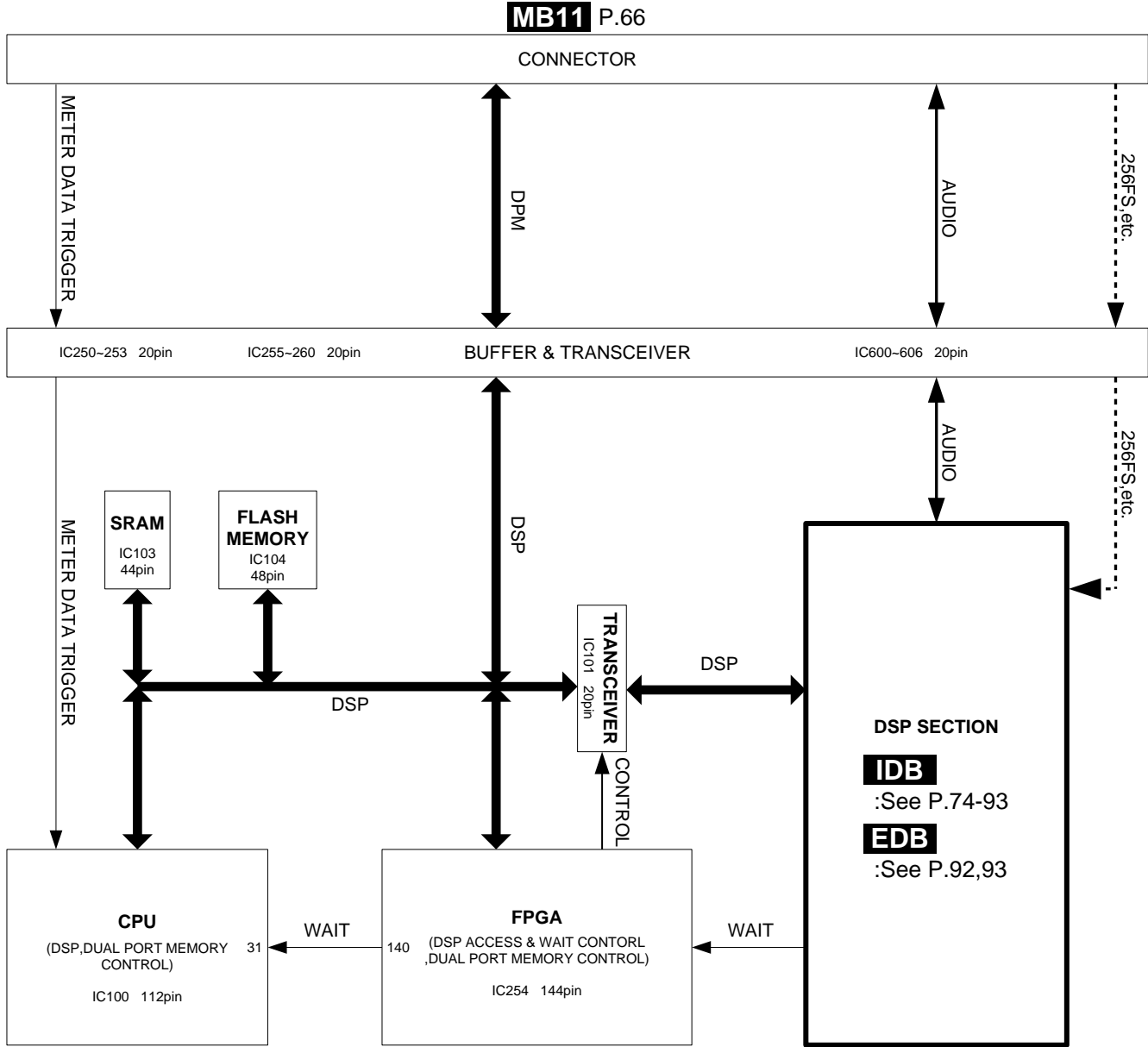

MB11 P.66

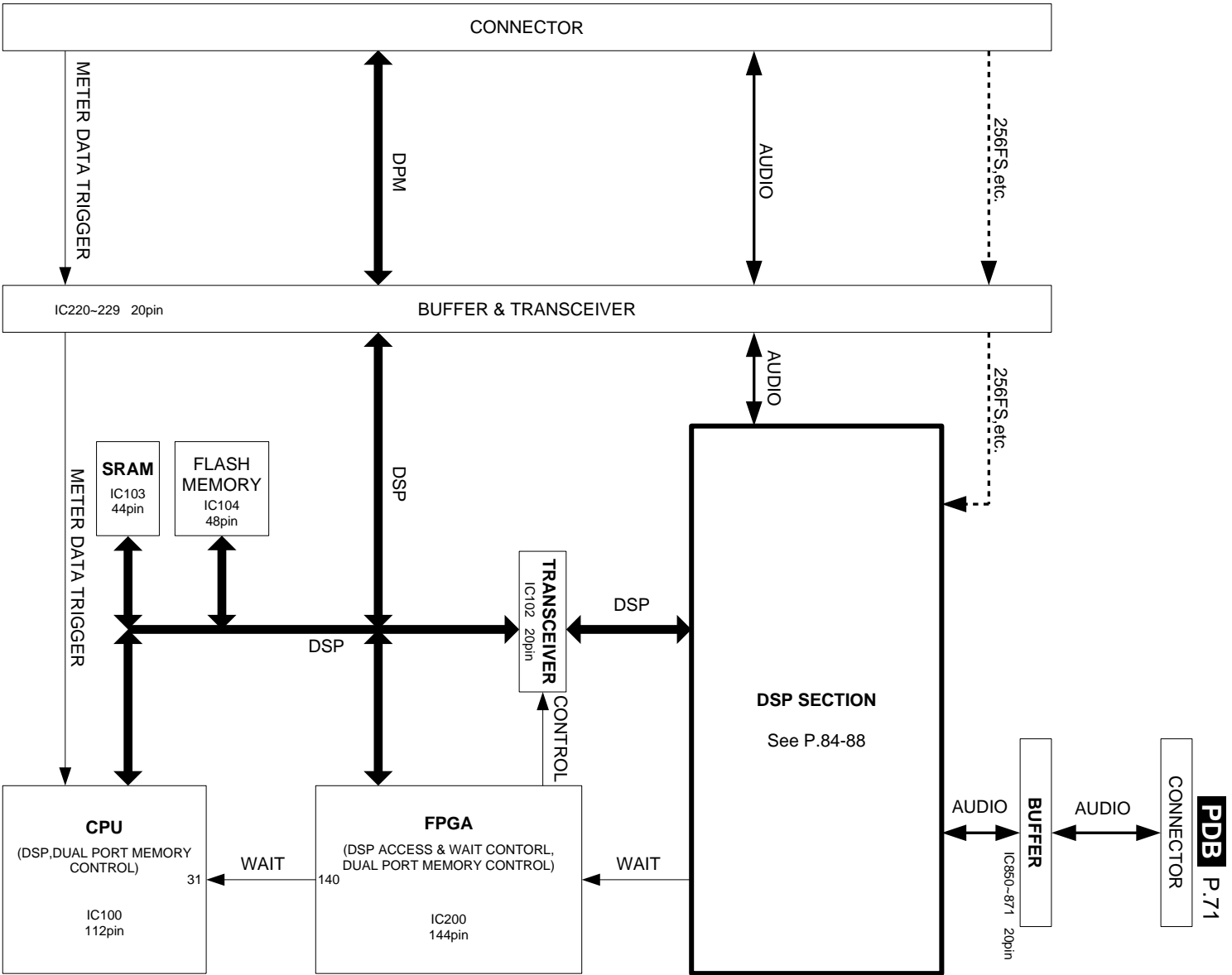

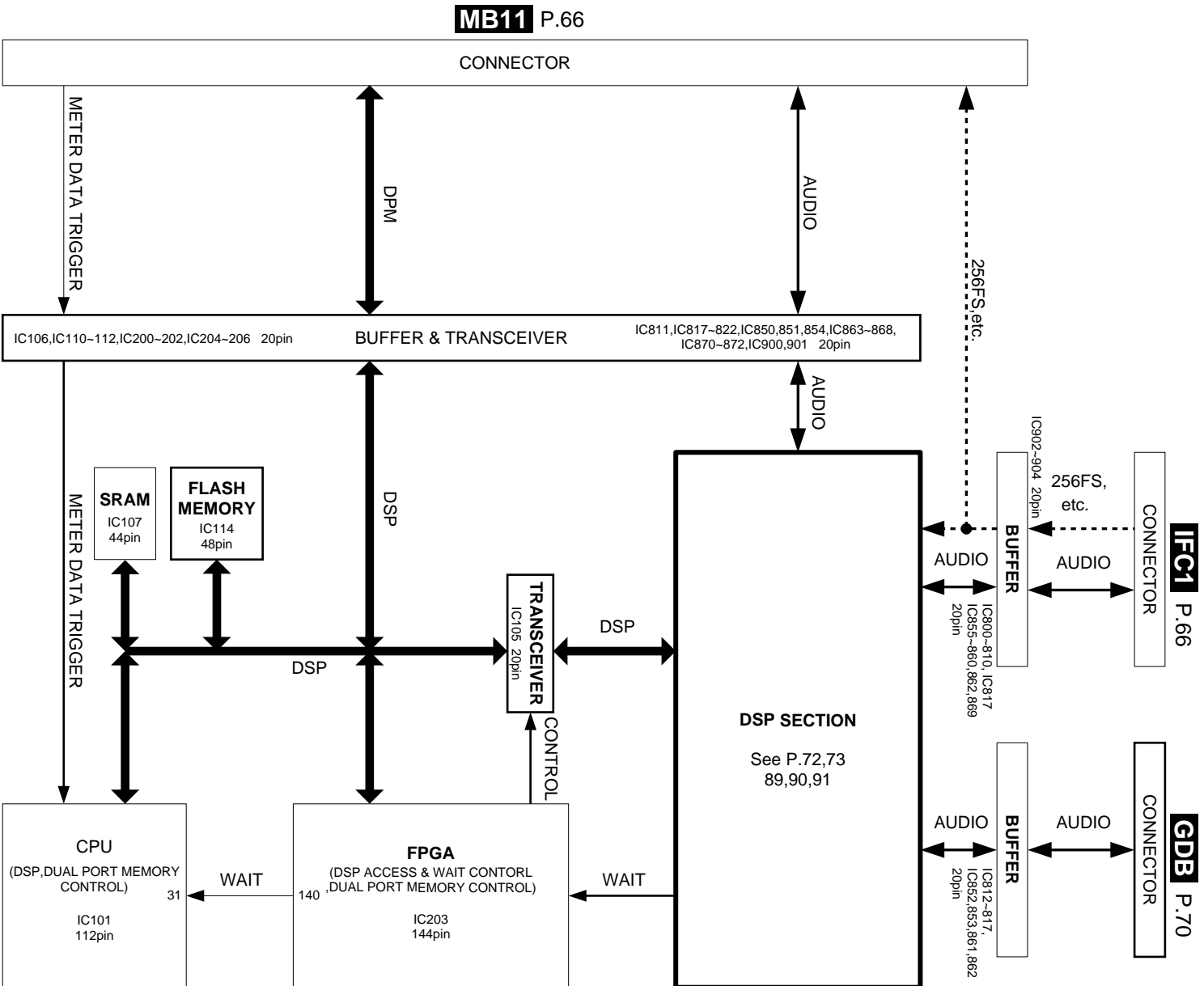

PDB

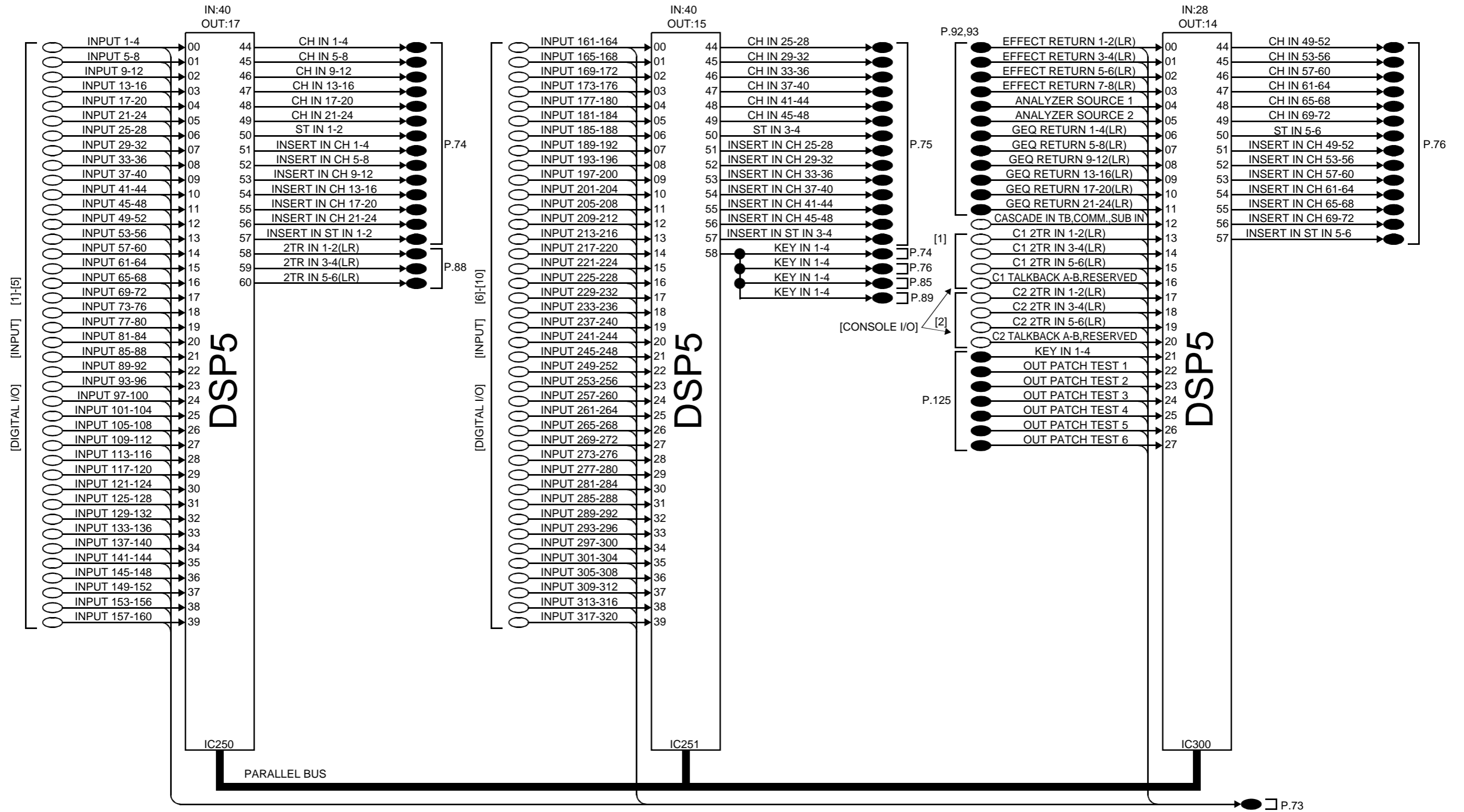

FUNCTION: INPUT PATCH, PEAK METER

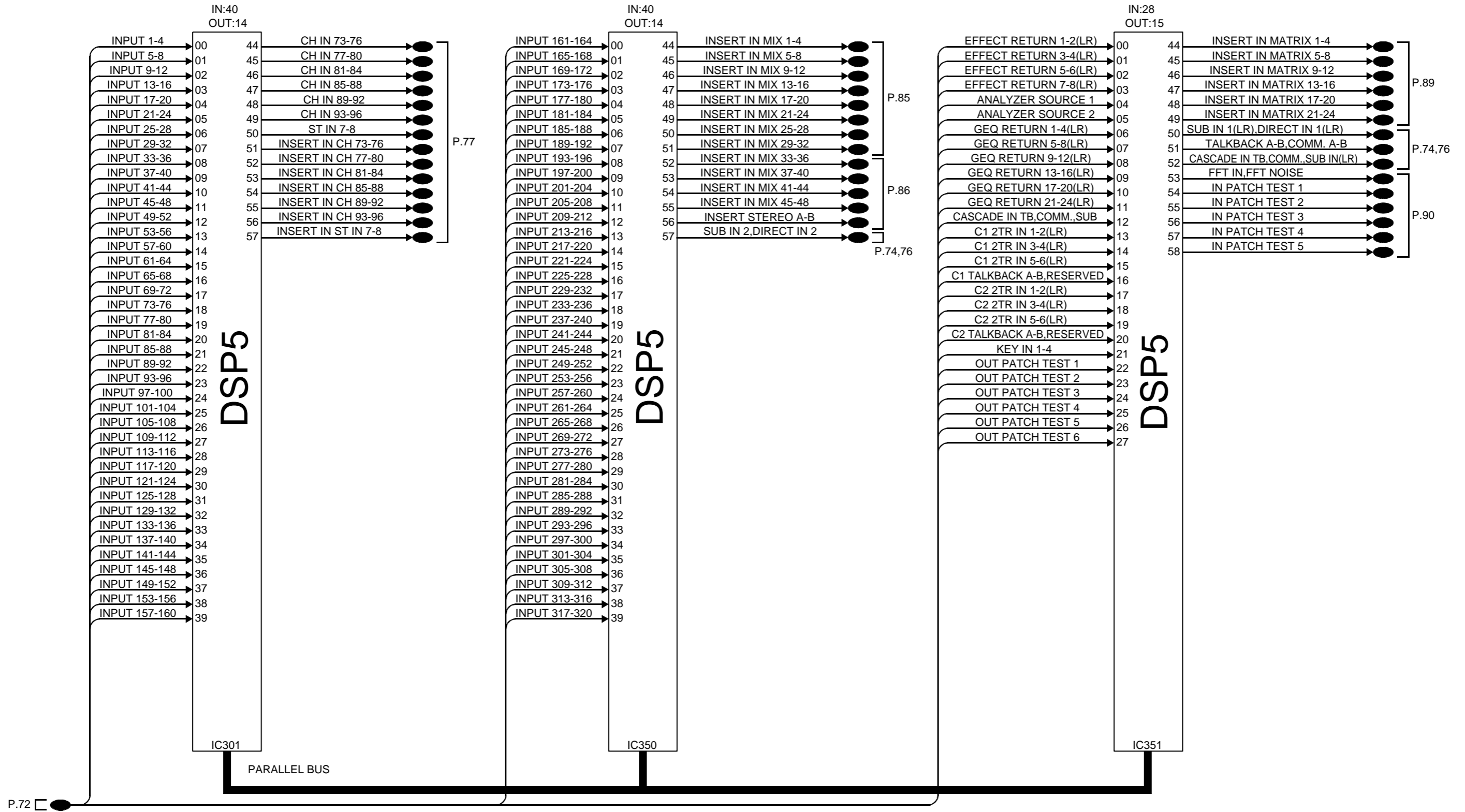

FUNCTION: INPUT PATCH, PEAK METER

PDB

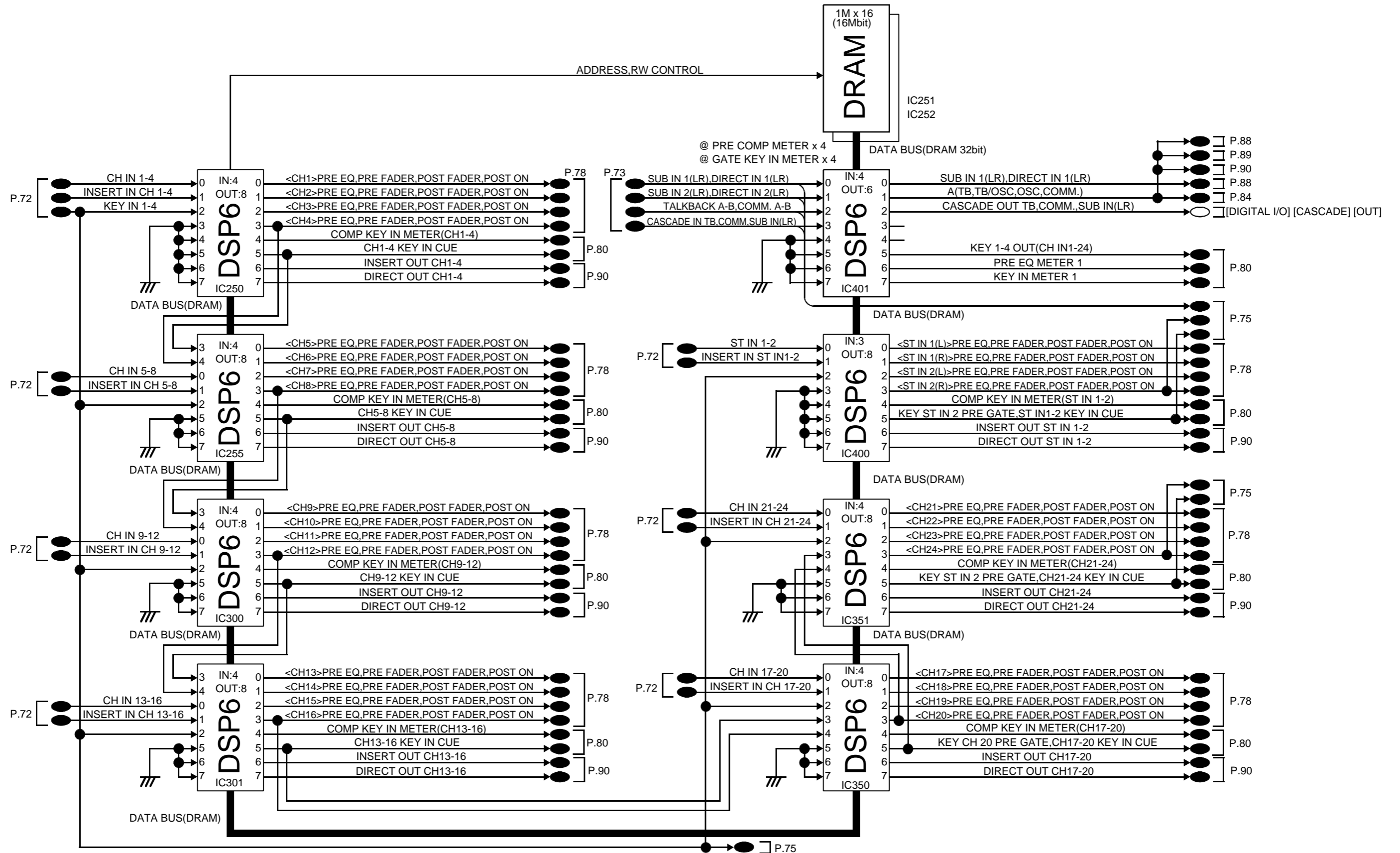

FUNCTION: INPUT EQ/GATE/COMP/DELAY/FADER ON

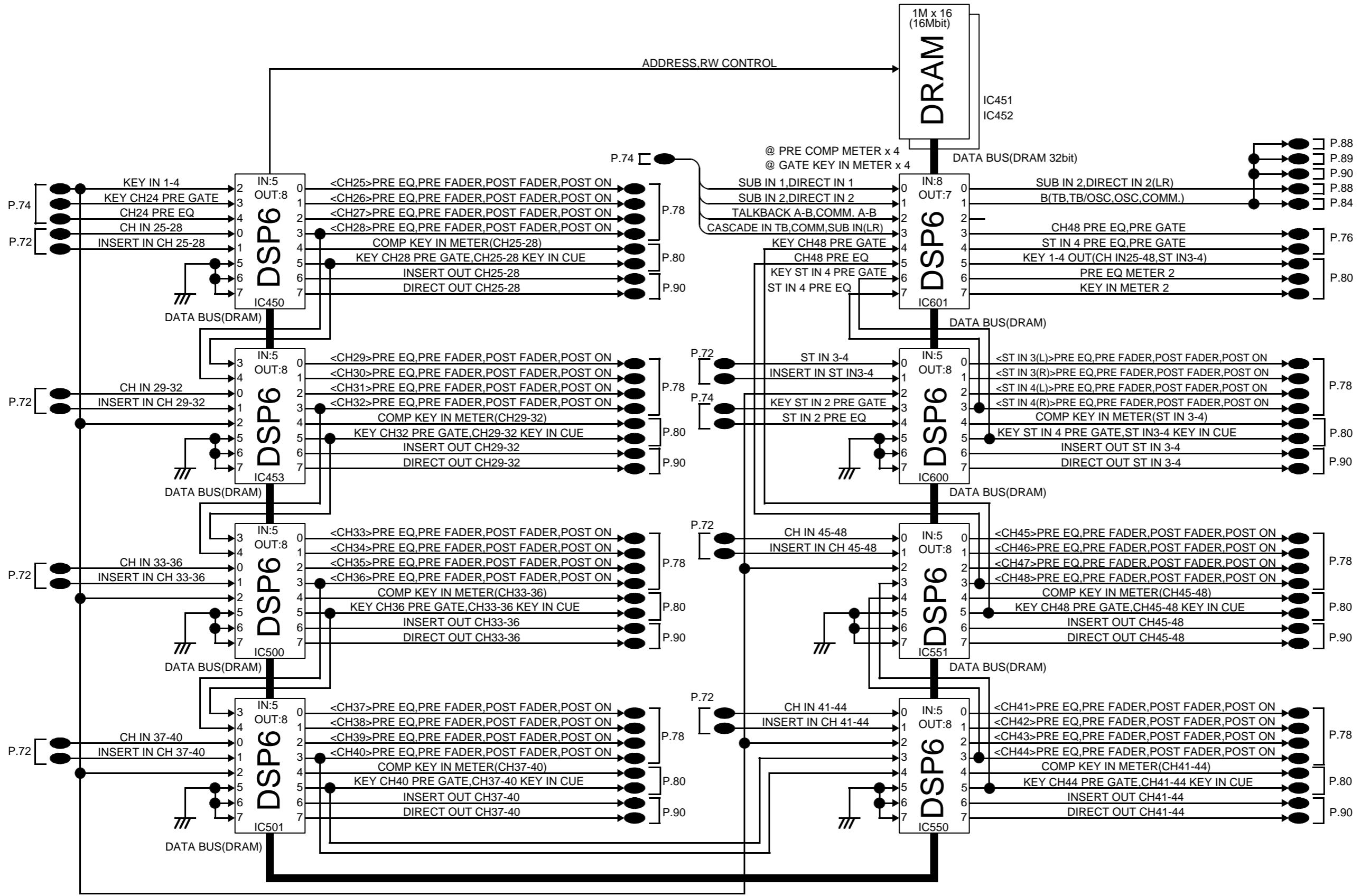

FUNCTION: INPUT EQ/GATE/COMP/DELAY/FADER ON

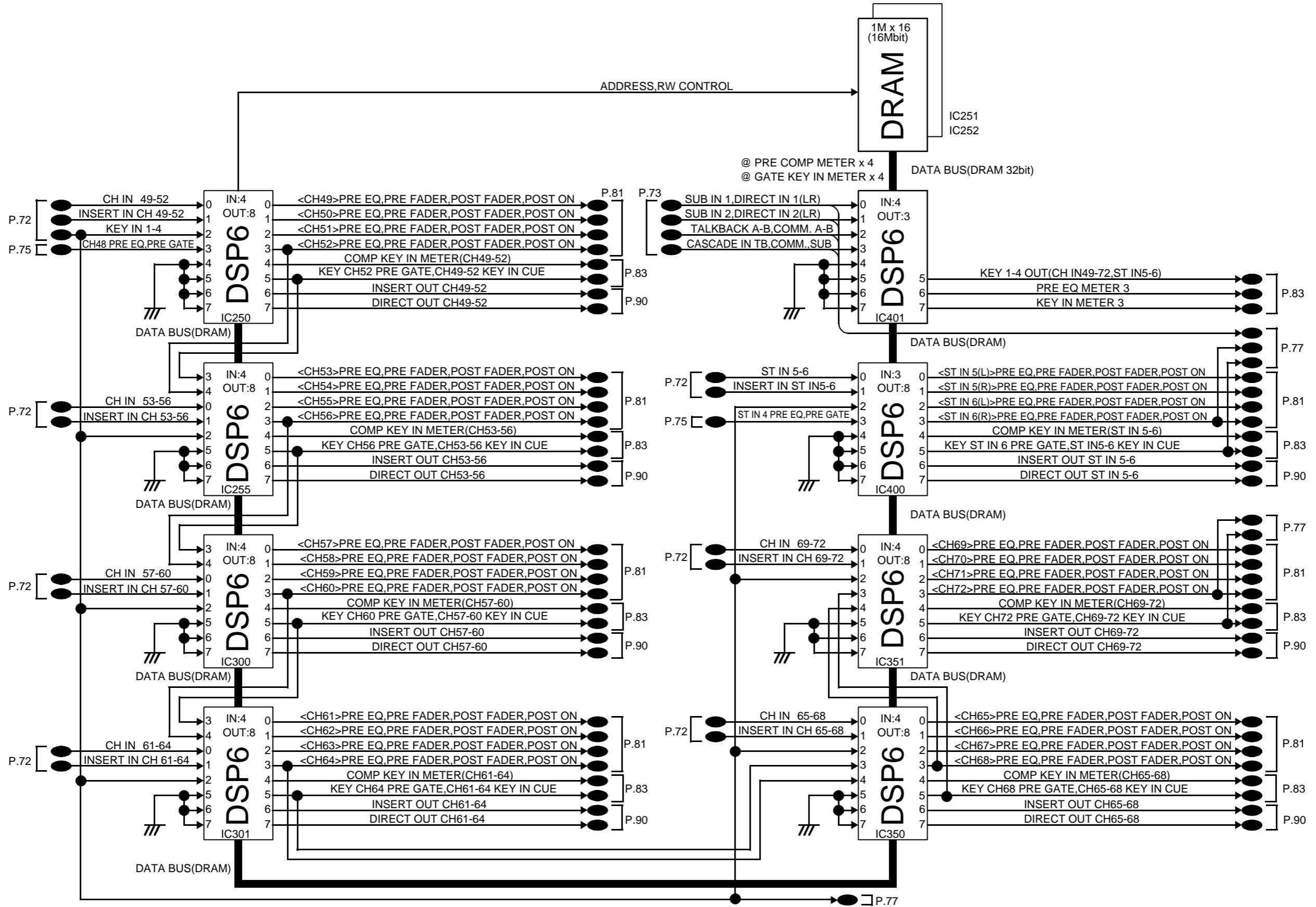

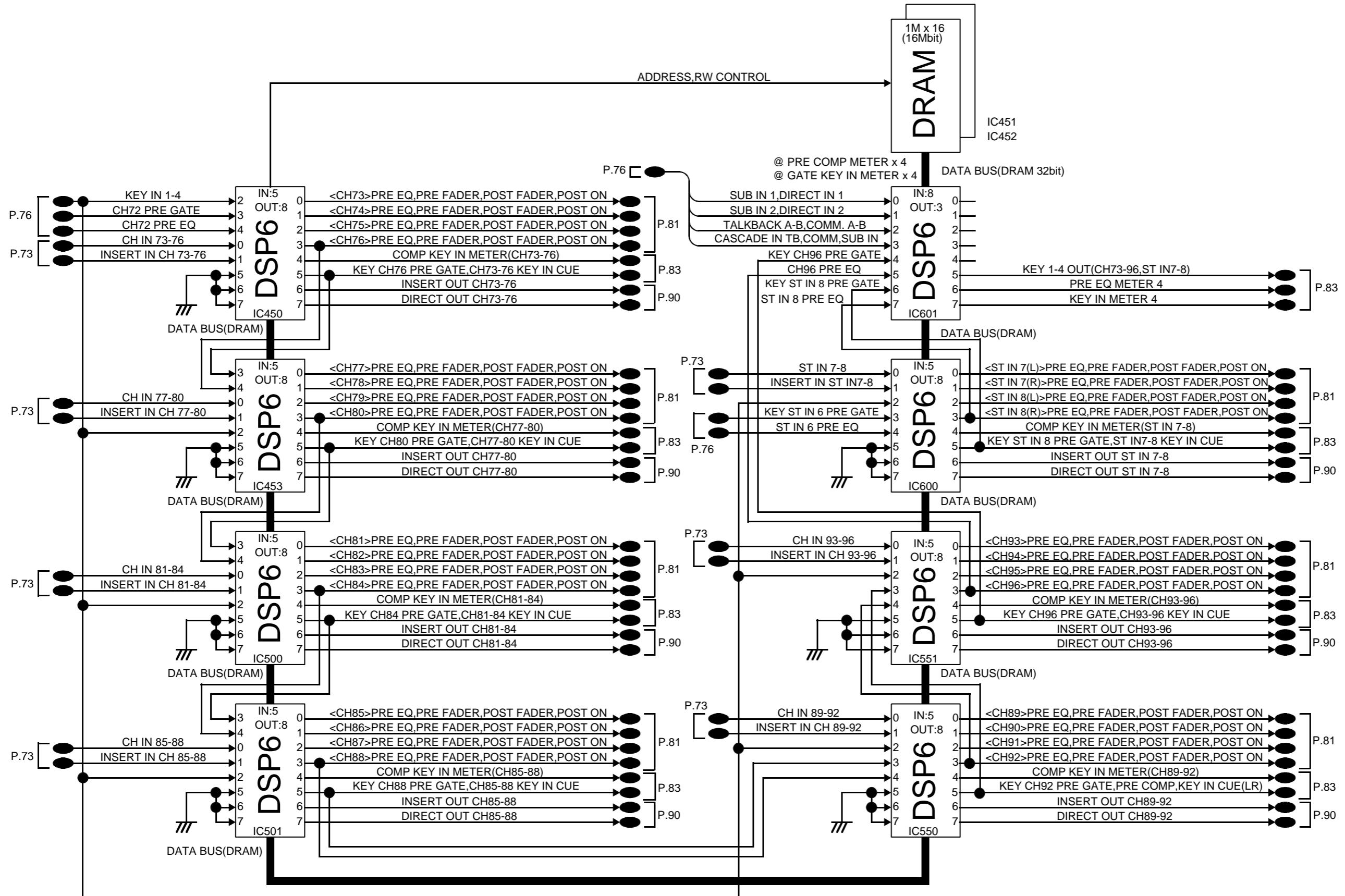

FUNCTION: INPUT EQ/GATE/COMP/DELAY/FADER ON

(FOR DSP1D-EX)

IDB (49-96)

KEC-92538-21

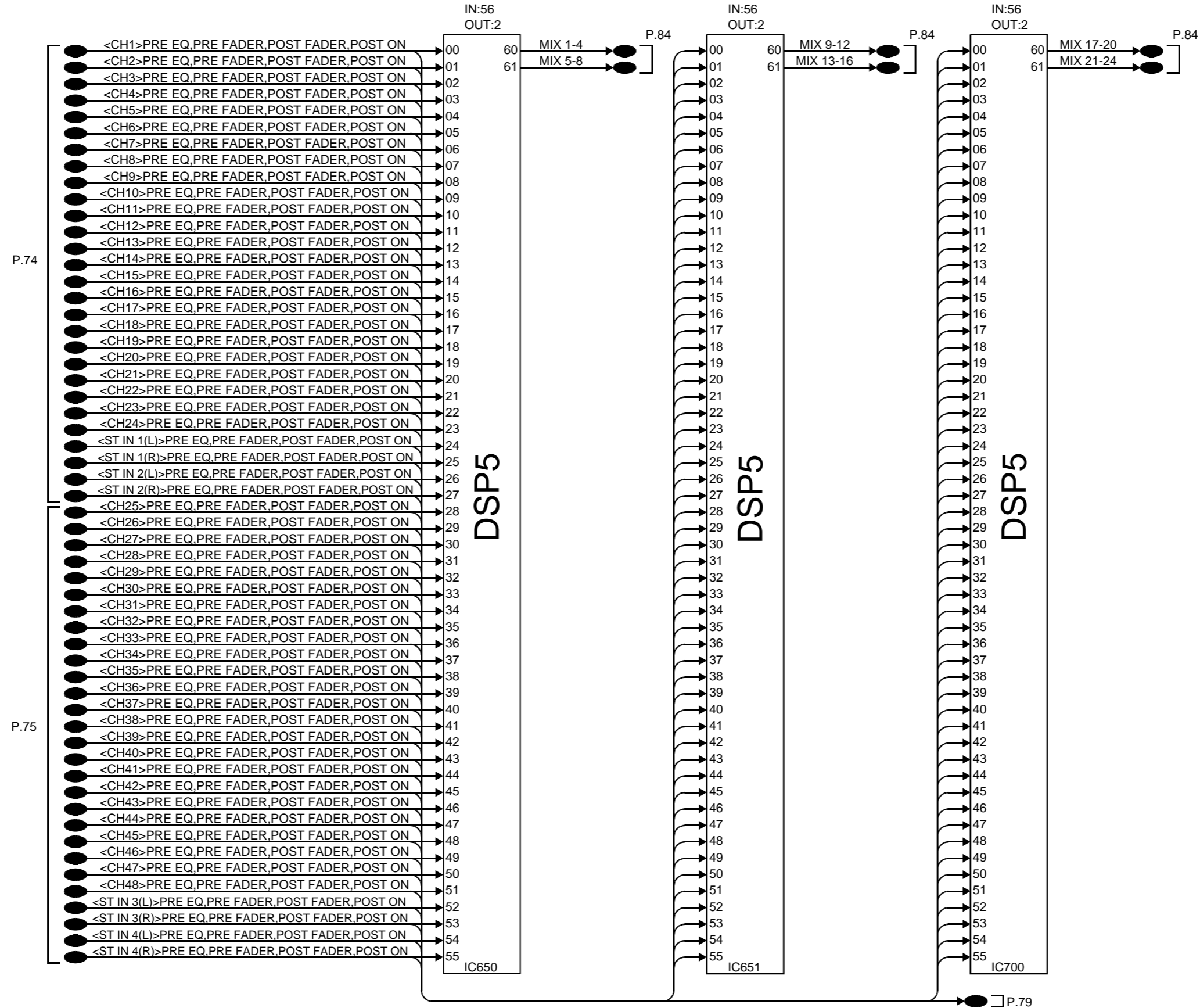

FUNCTION: <CH1-48,ST IN1-4>PAN,MIX/STEREO/CUE/KEY IN,METER

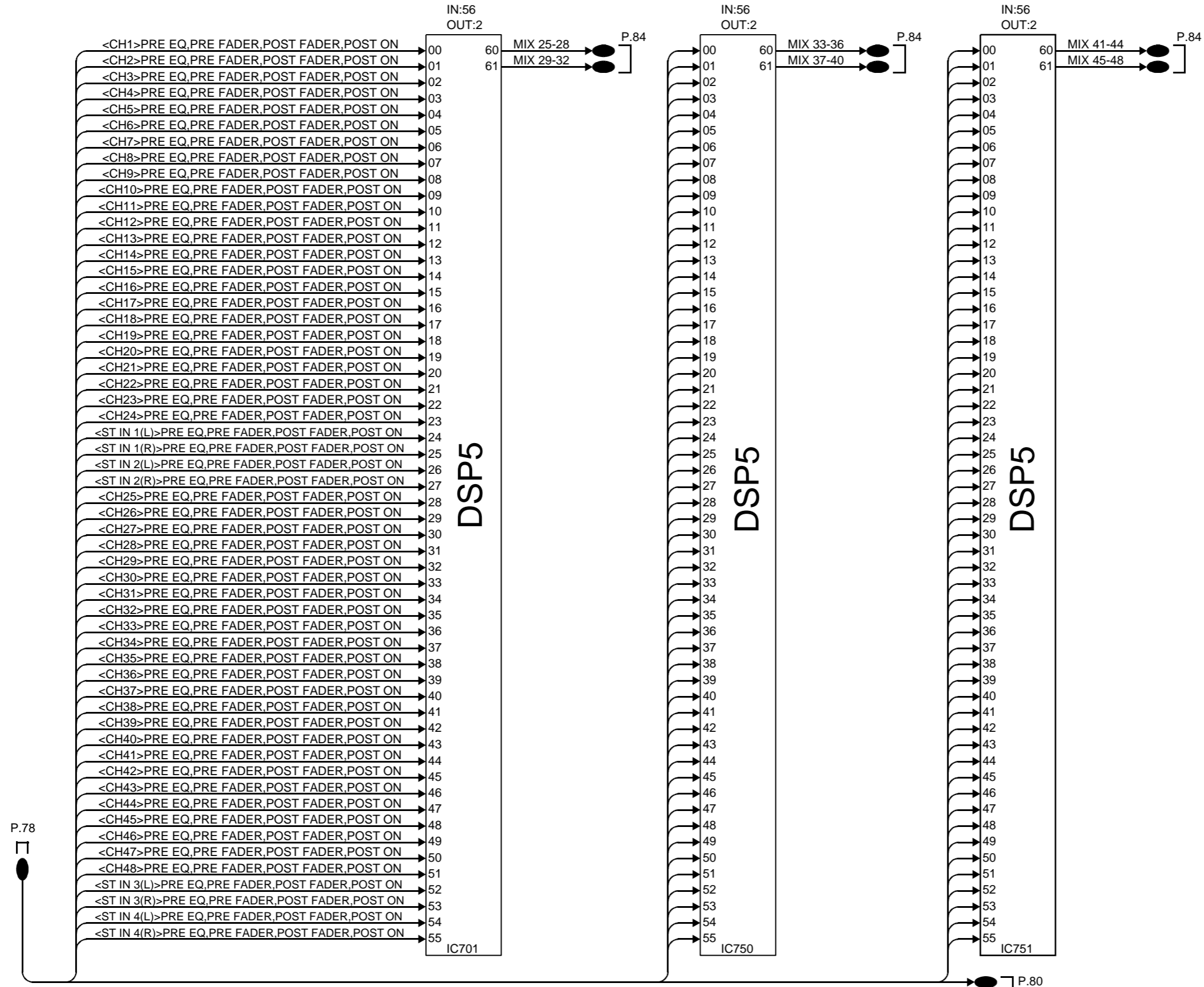

FUNCTION: <CH1-48,ST IN1-4>PAN,MIX/STEREO/CUE/KEY IN,METER

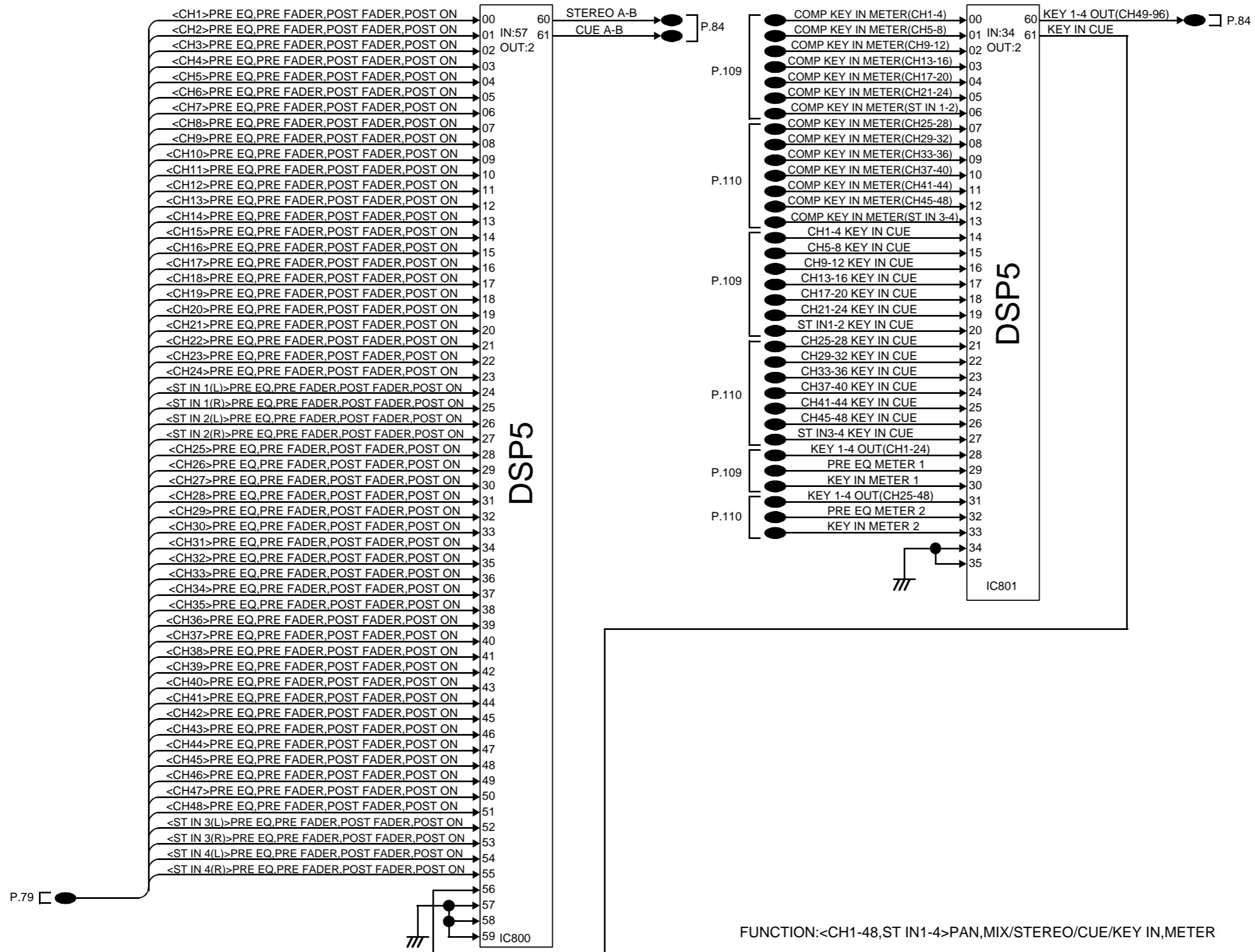

FUNCTION:<CH1-48,ST IN1-4>PAN,MIX/STEREO/CUE/KEY IN,METER

IDB (1-48)

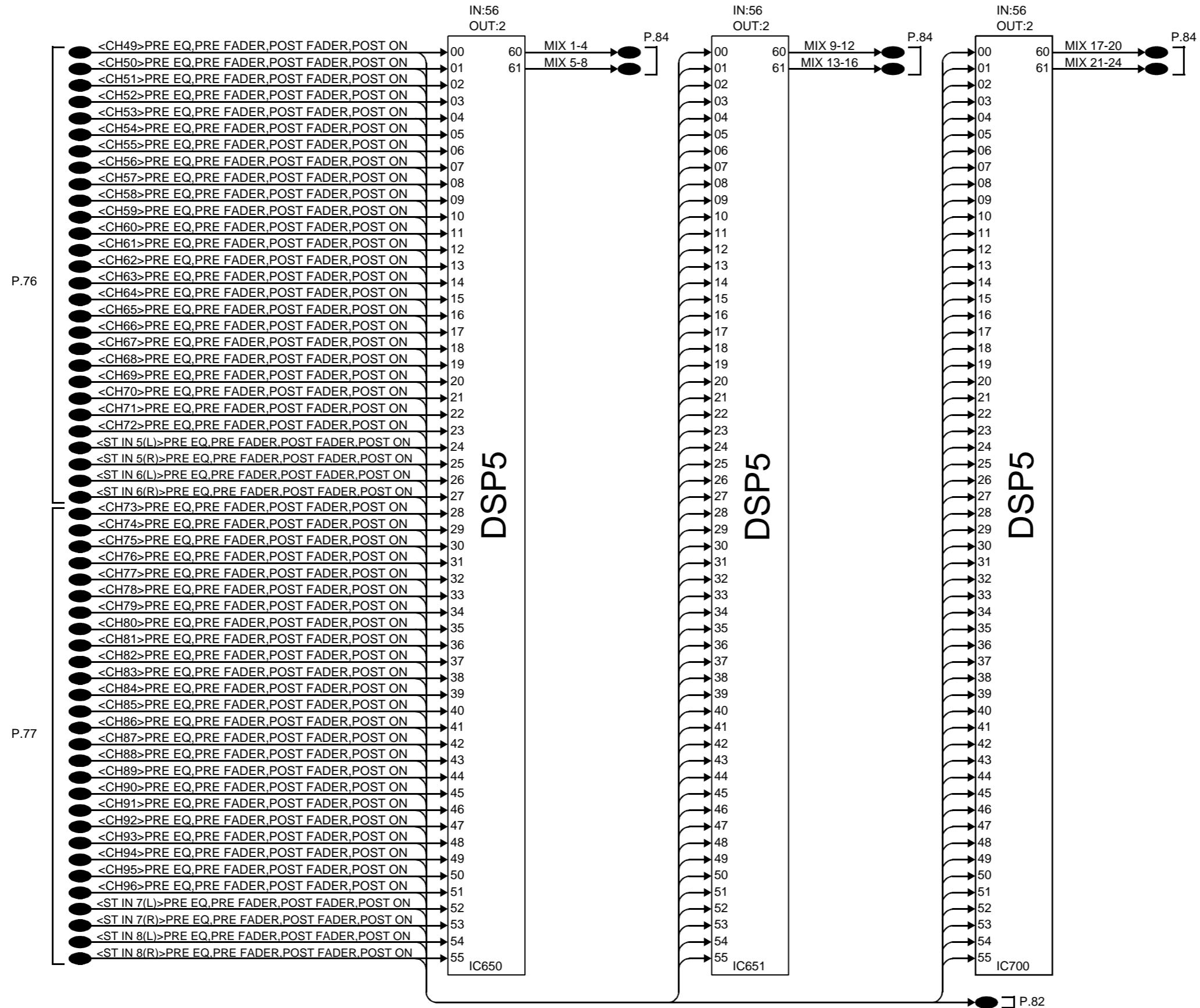

FUNCTION: <CH49-96,ST IN5-8>PAN,MIX/STEREO/CUE/KEY IN,METER

(FOR DSP1D-EX)

IDB (49-96)

KEC-92538-25

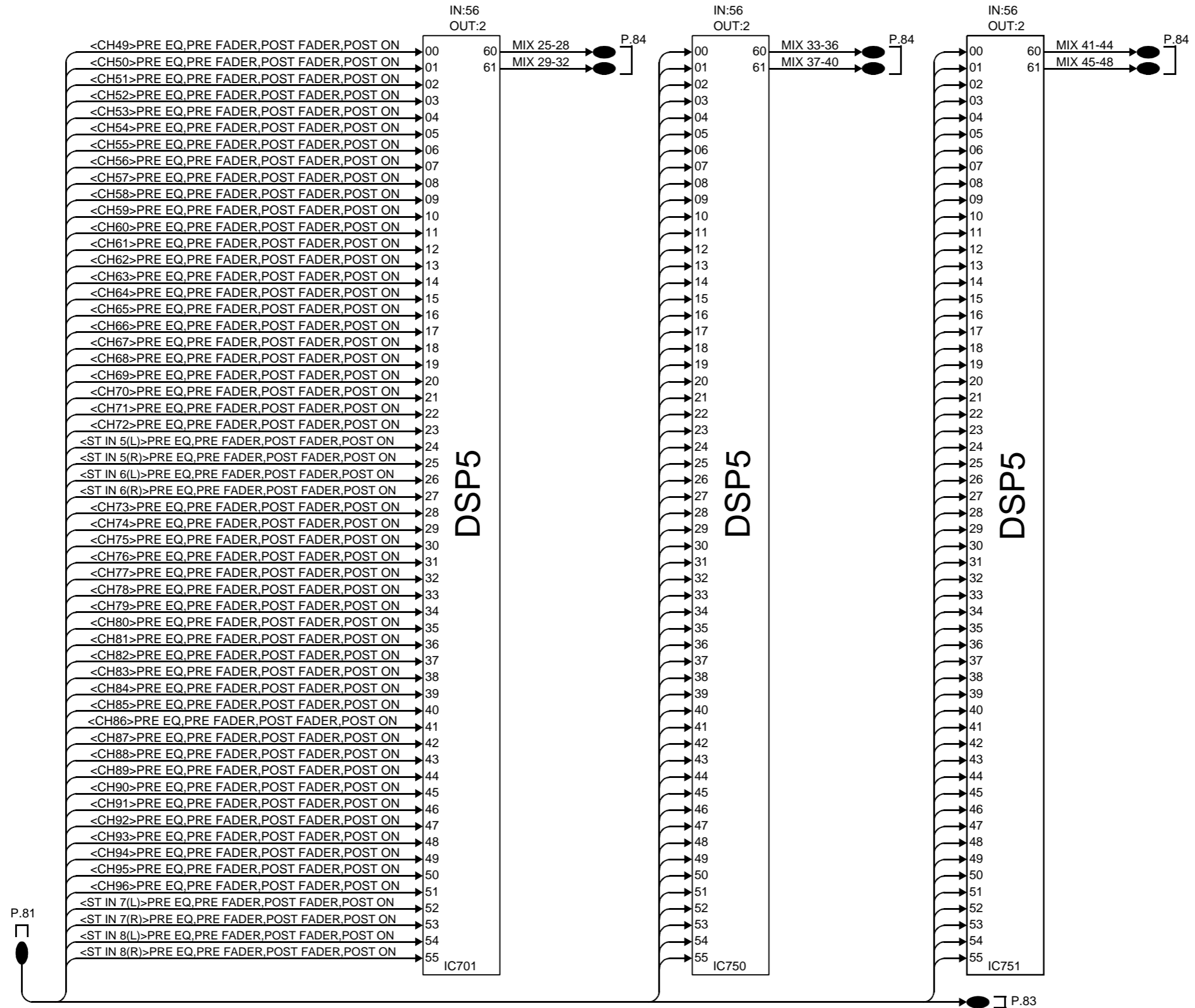

FUNCTION: <CH49-96,ST IN5-8>PAN,MIX/STEREO/CUE/KEY IN,METER

(FOR DSP1D-EX)

IDB (49-96)

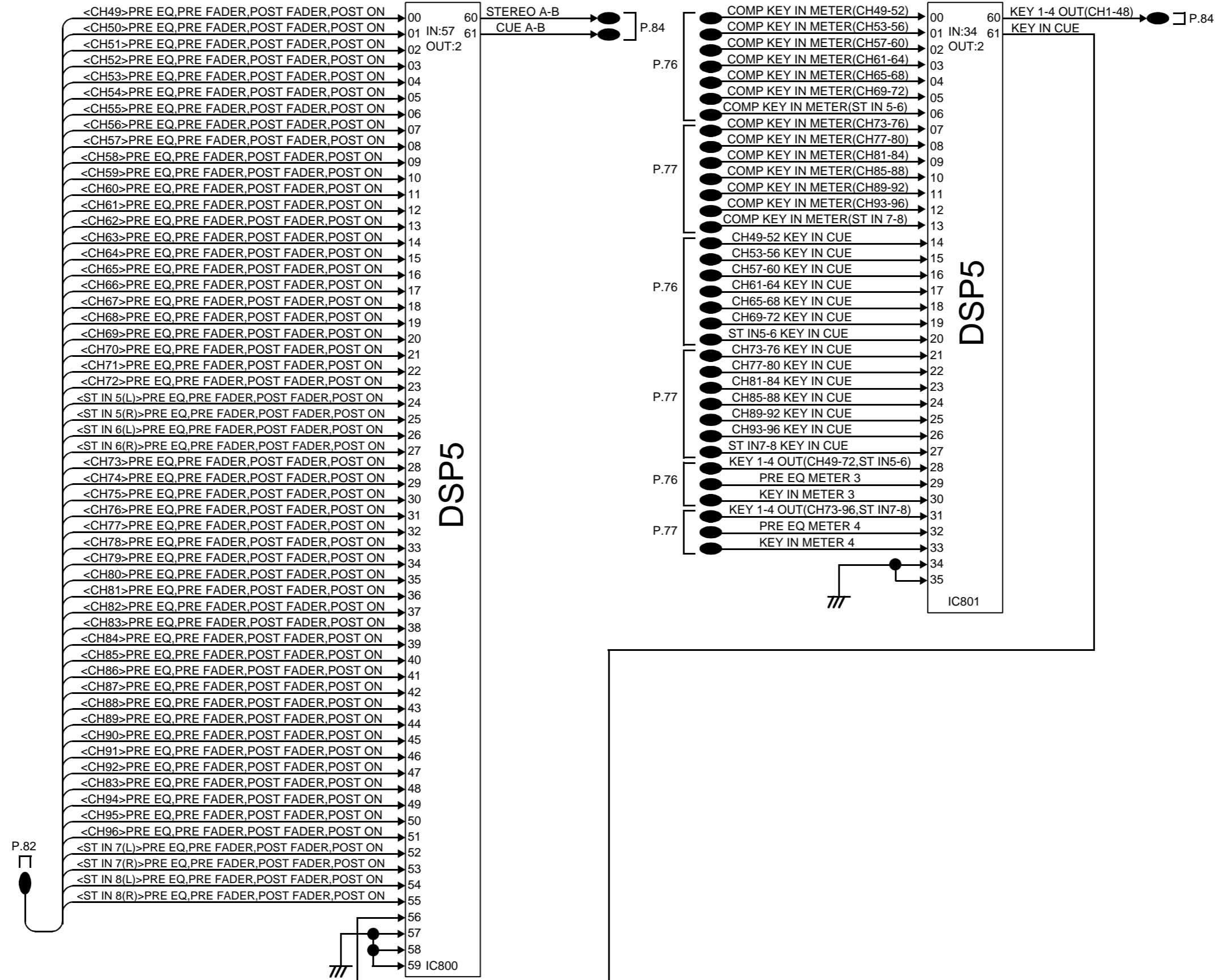

FUNCTION: <CH49-96,ST IN5-8>PAN,MIX/STEREO/CUE/KEY IN,METER

(FOR DSP1D-EX)

IDB (49-96)

KEC-92538-27

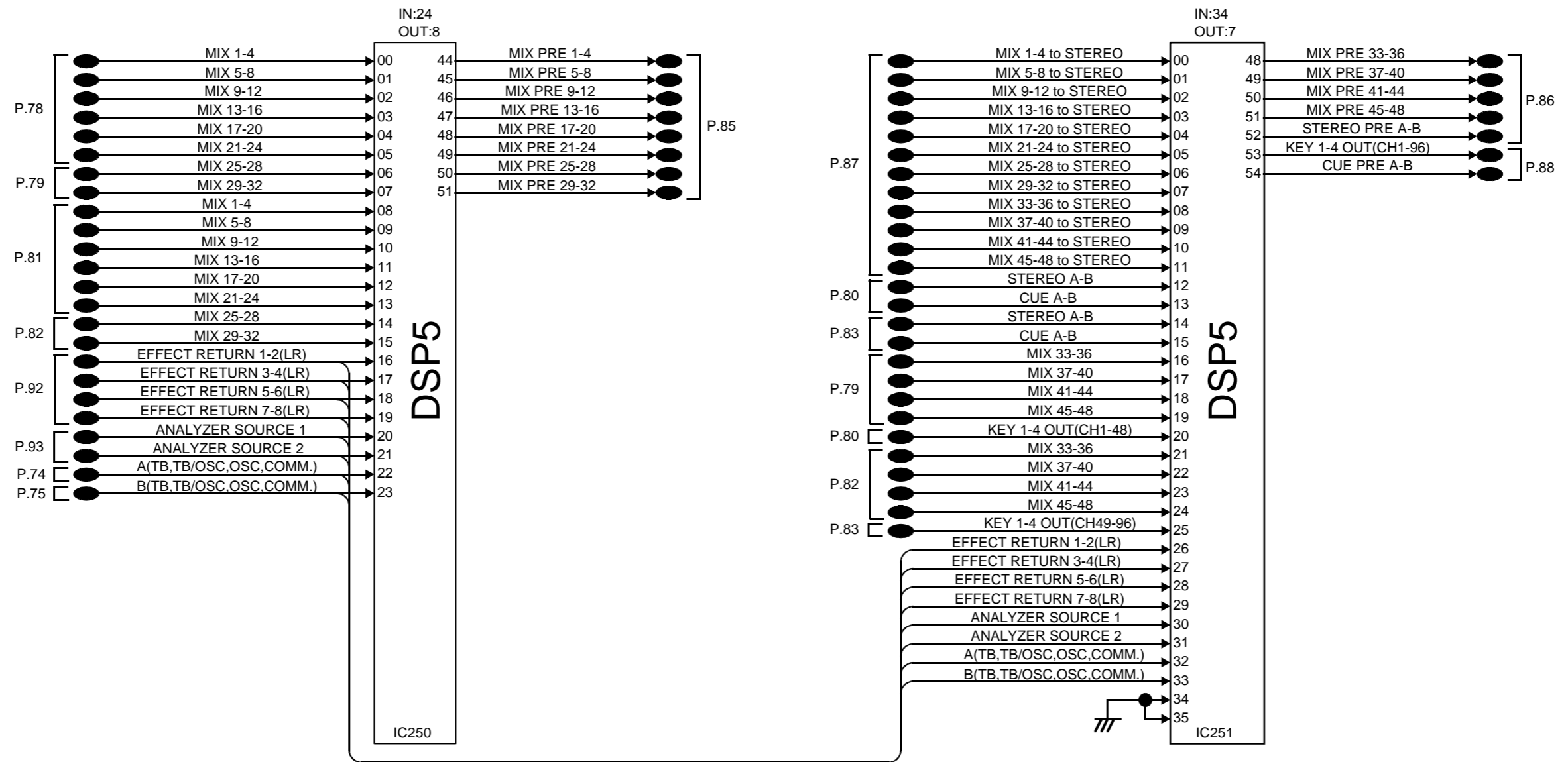

FUNCTION: MIX/STEREO/CUE/KEY IN

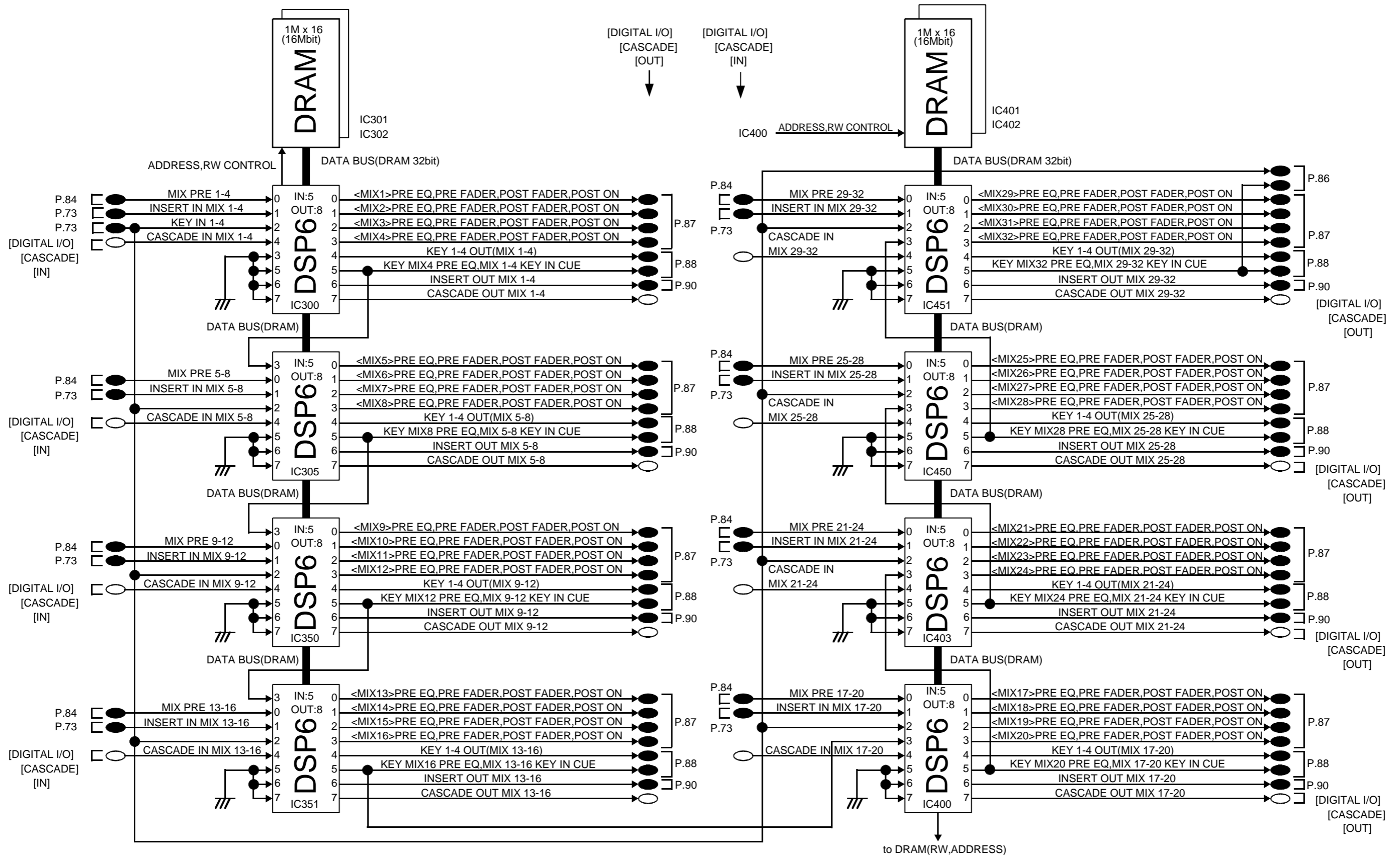

FUNCTION: MIX EQ/COMP/DELAY/FADER ON

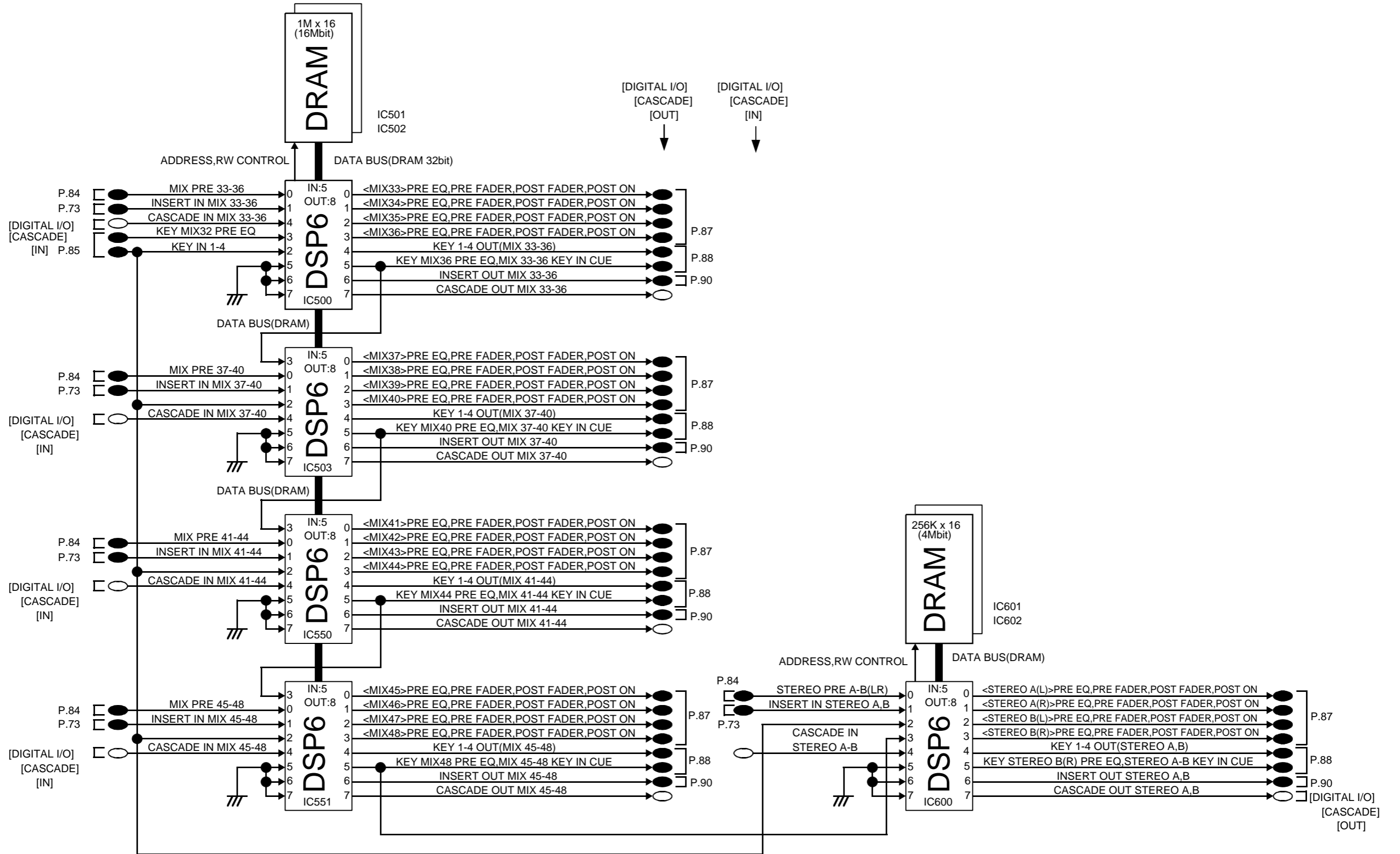

FUNCTION: MIX EQ/COMP/DELAY/FADER ON



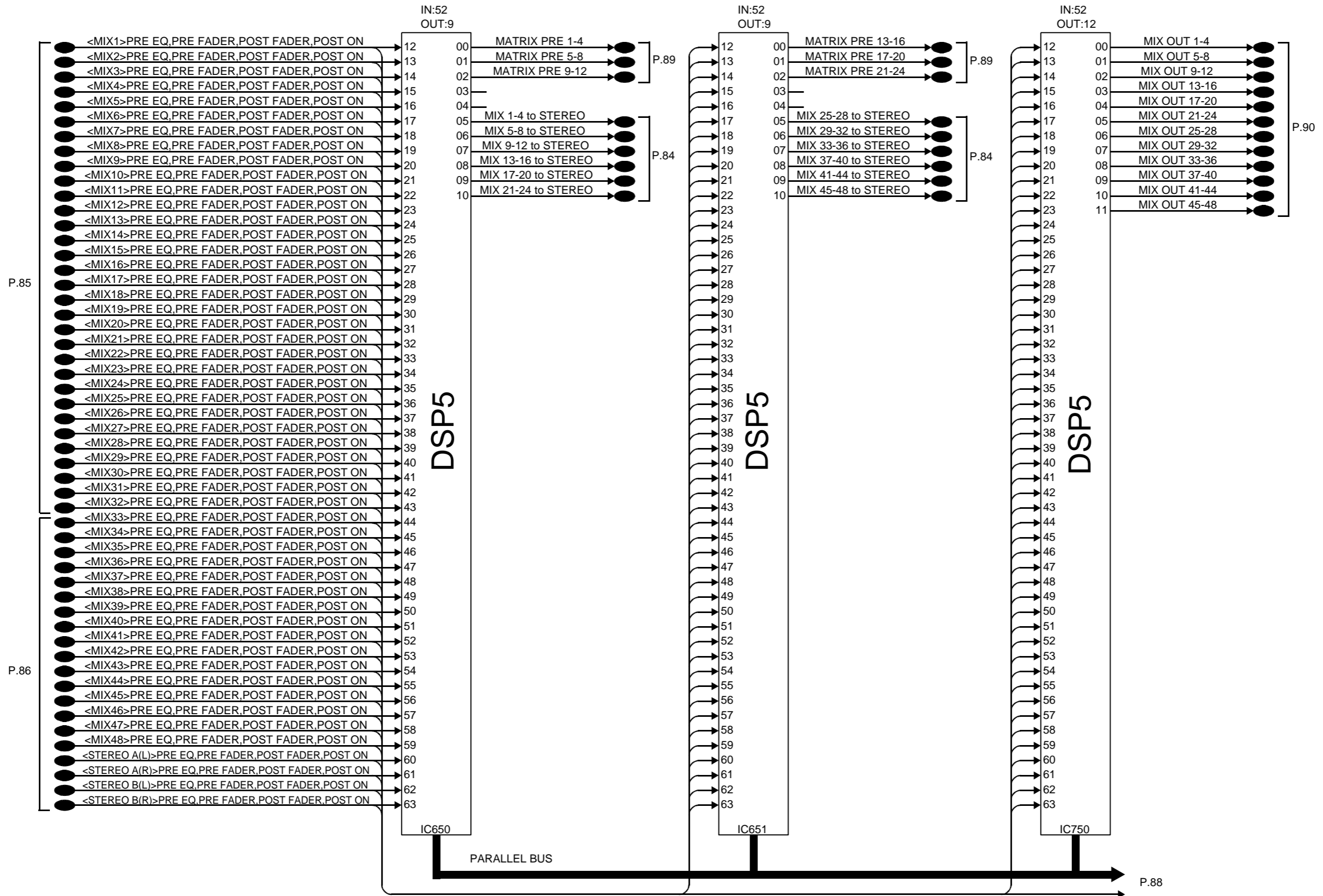

FUNCTION: MATRIX,CUE/MONITOR ADD.,KEY IN

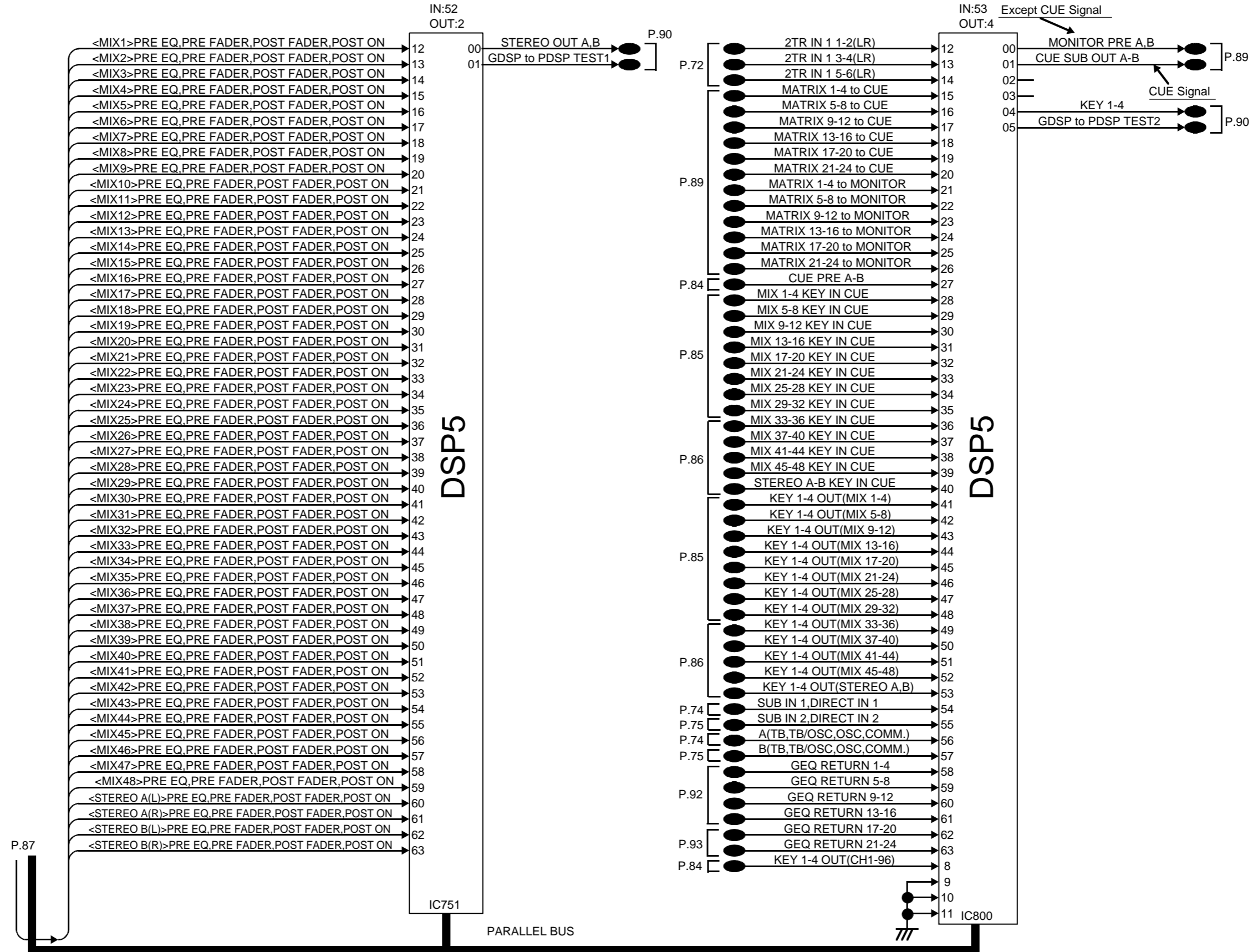

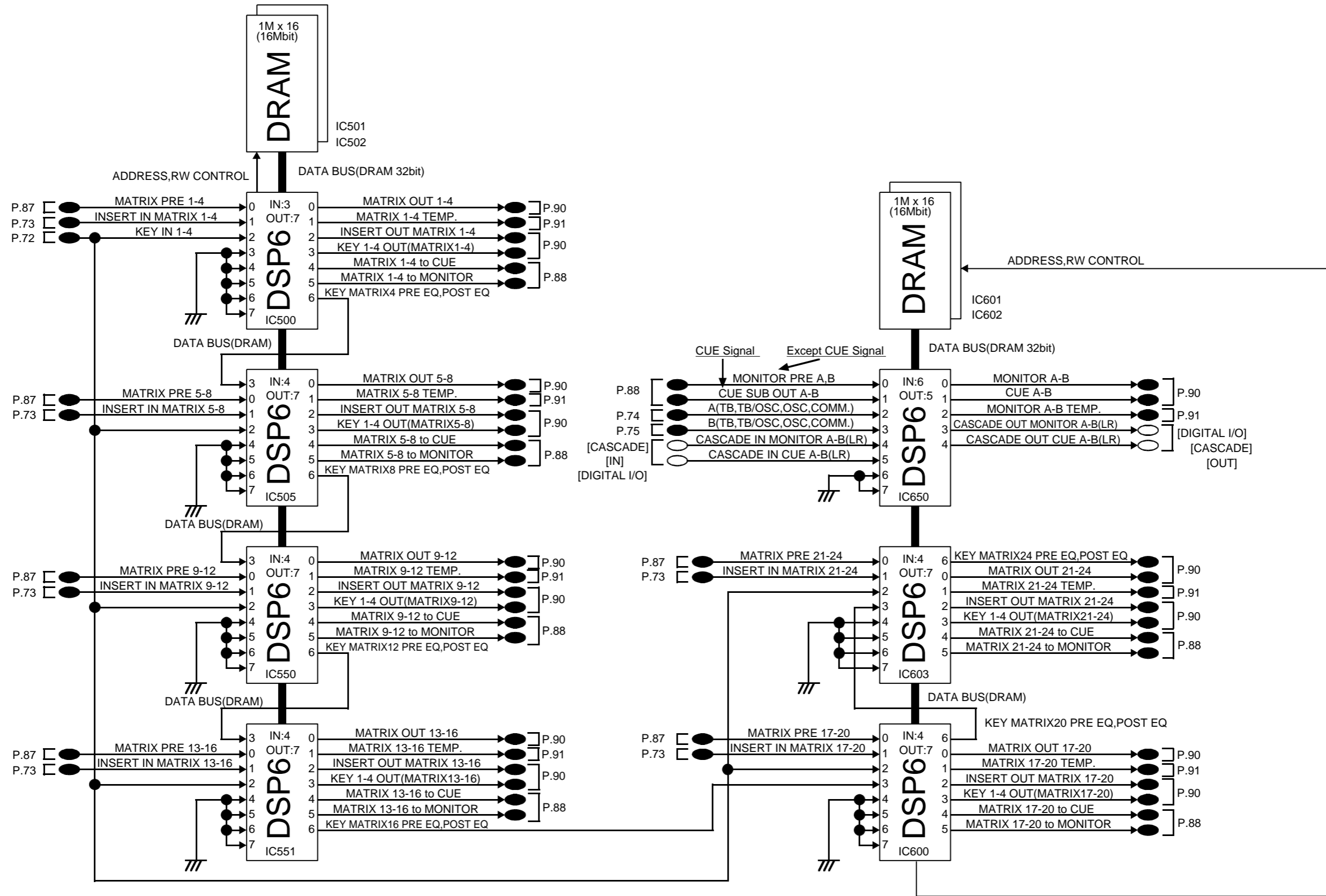

FUNCTION: MATRIX EQ/COMP/DELAY/FADER ON,MONITOR DELAY

PDB

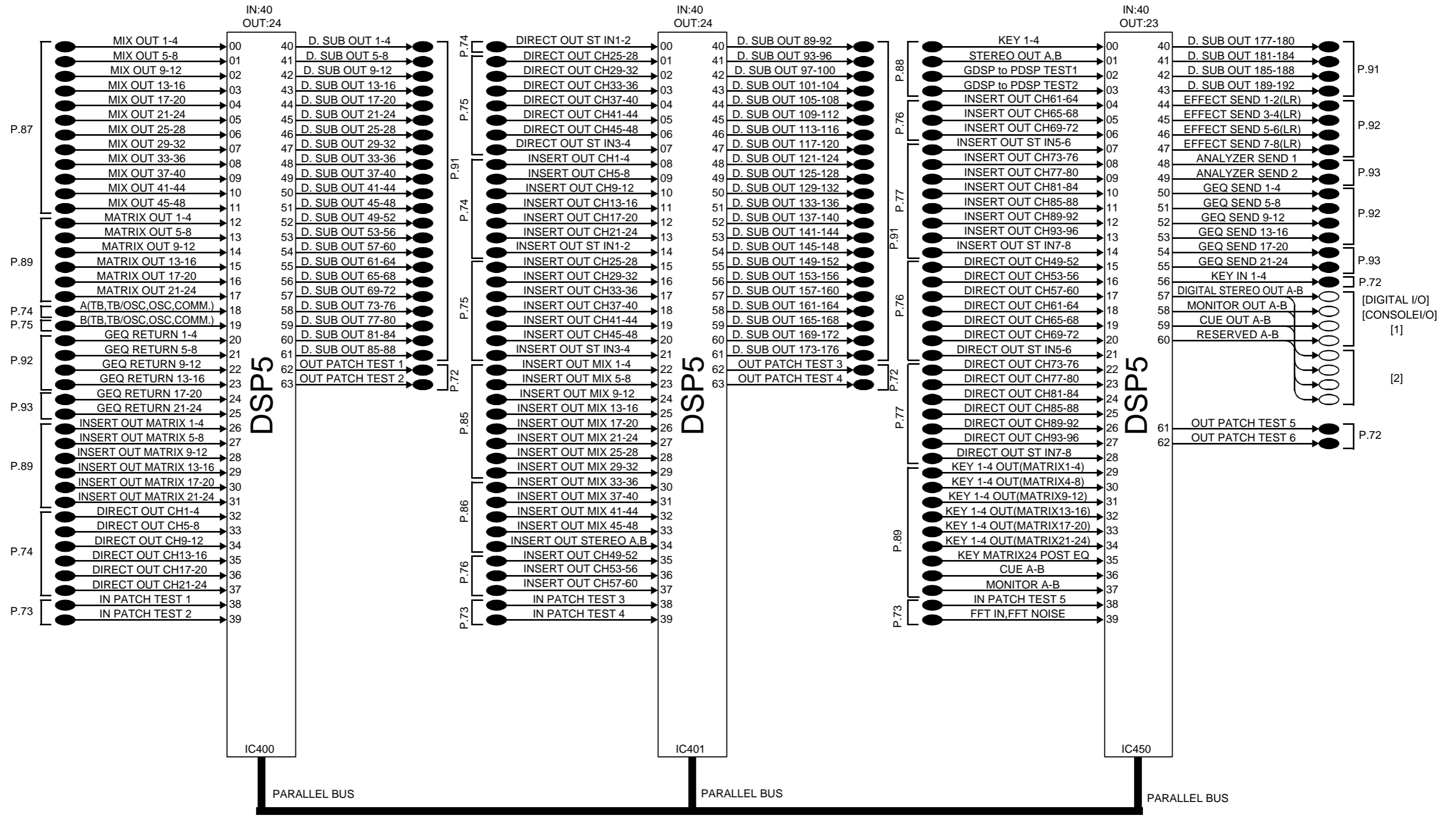

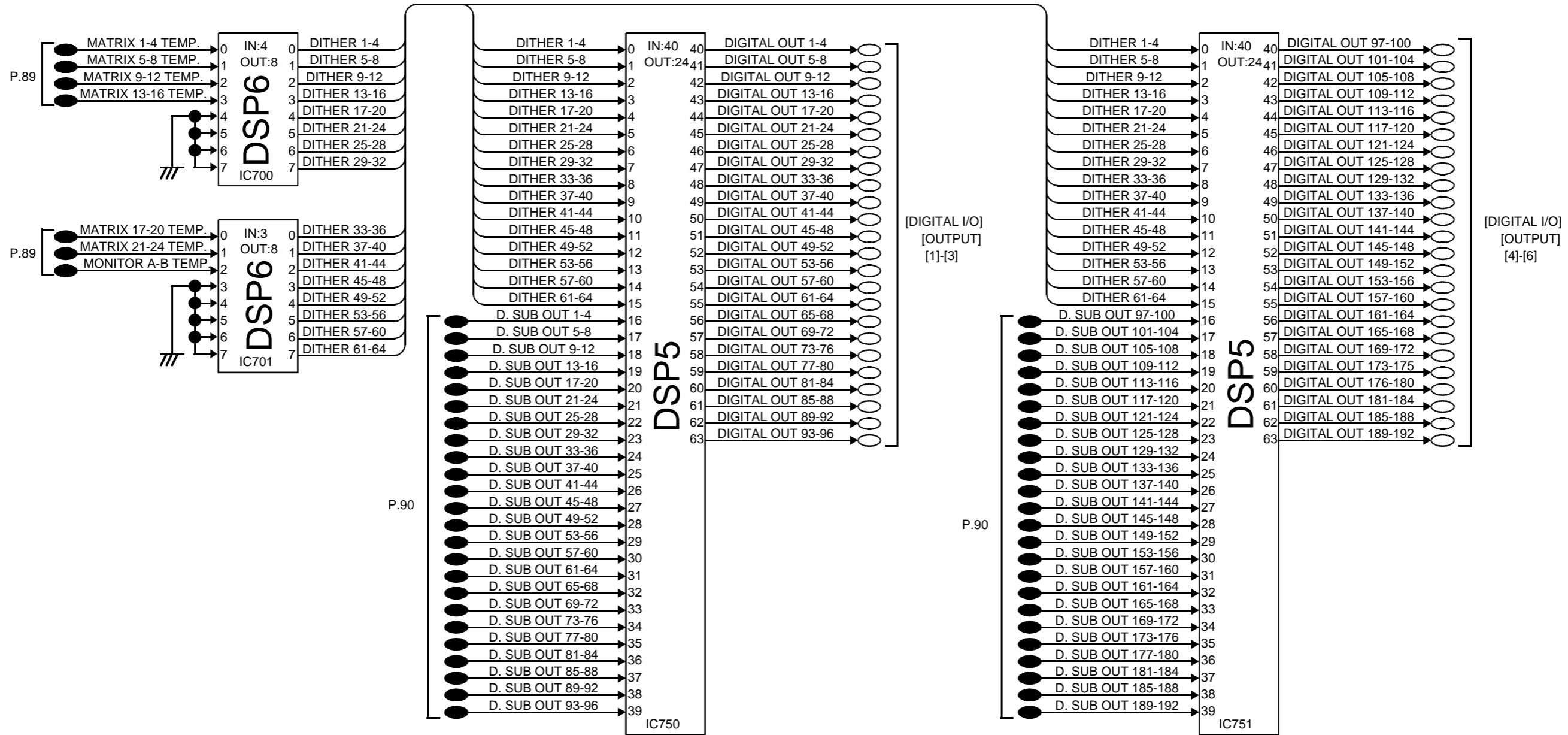

FUNCTION: DITHER

PDB

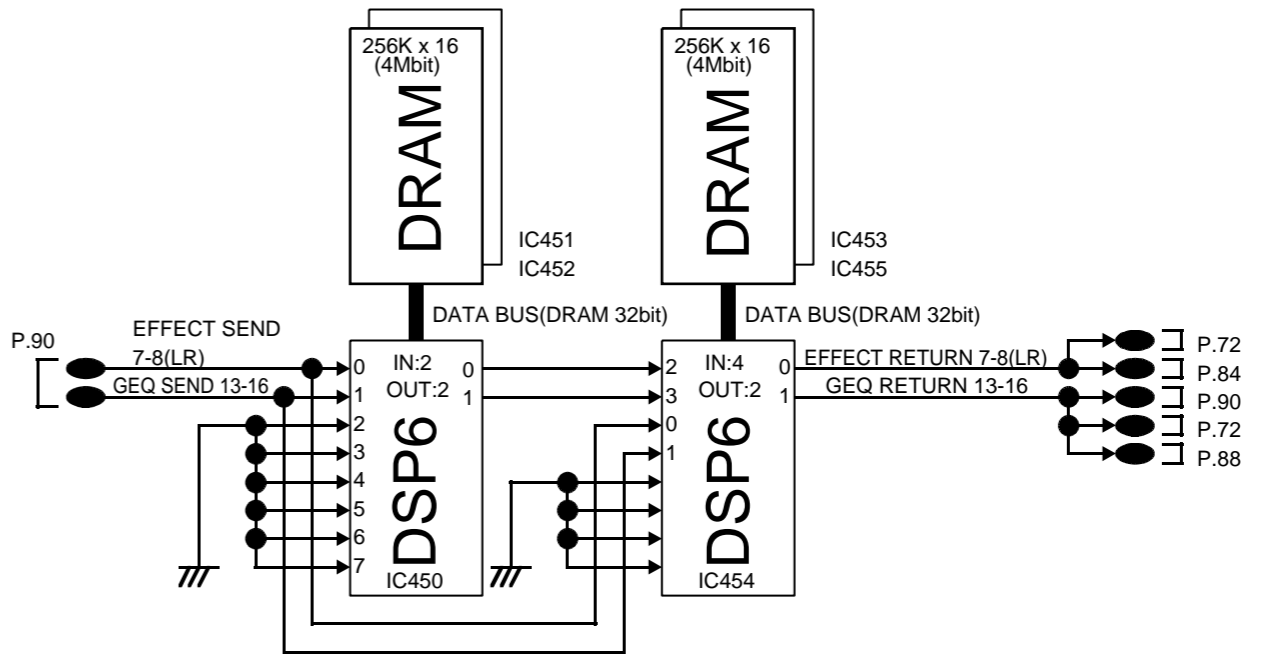
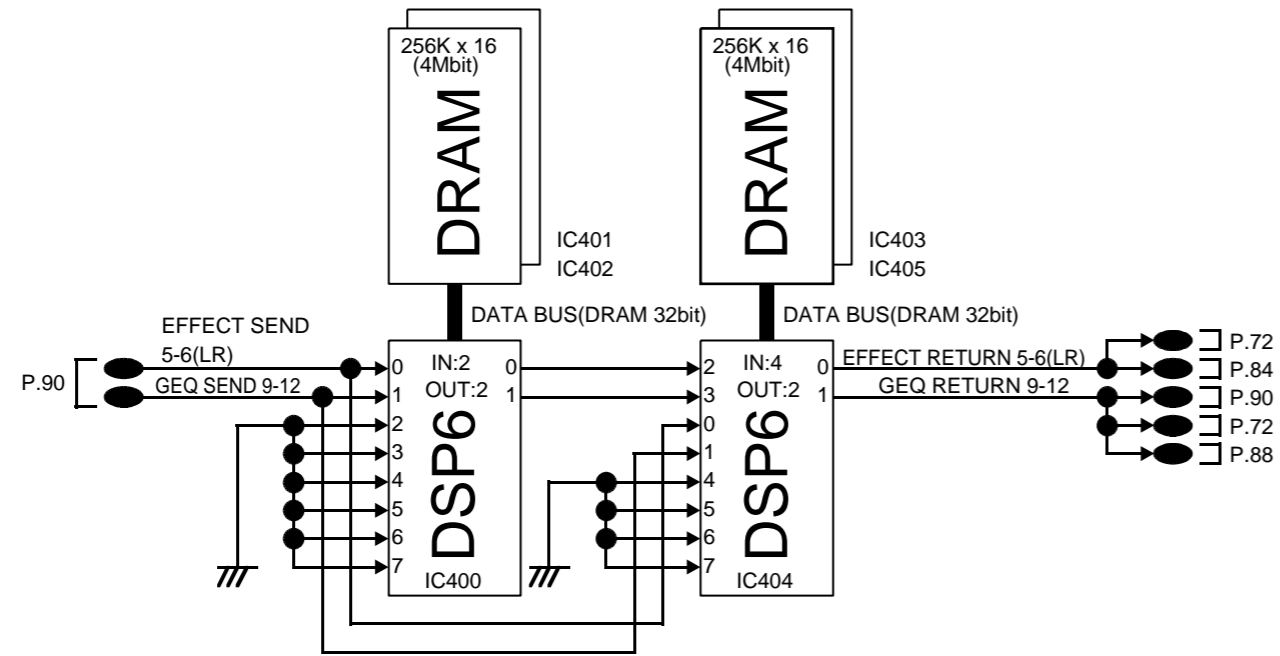
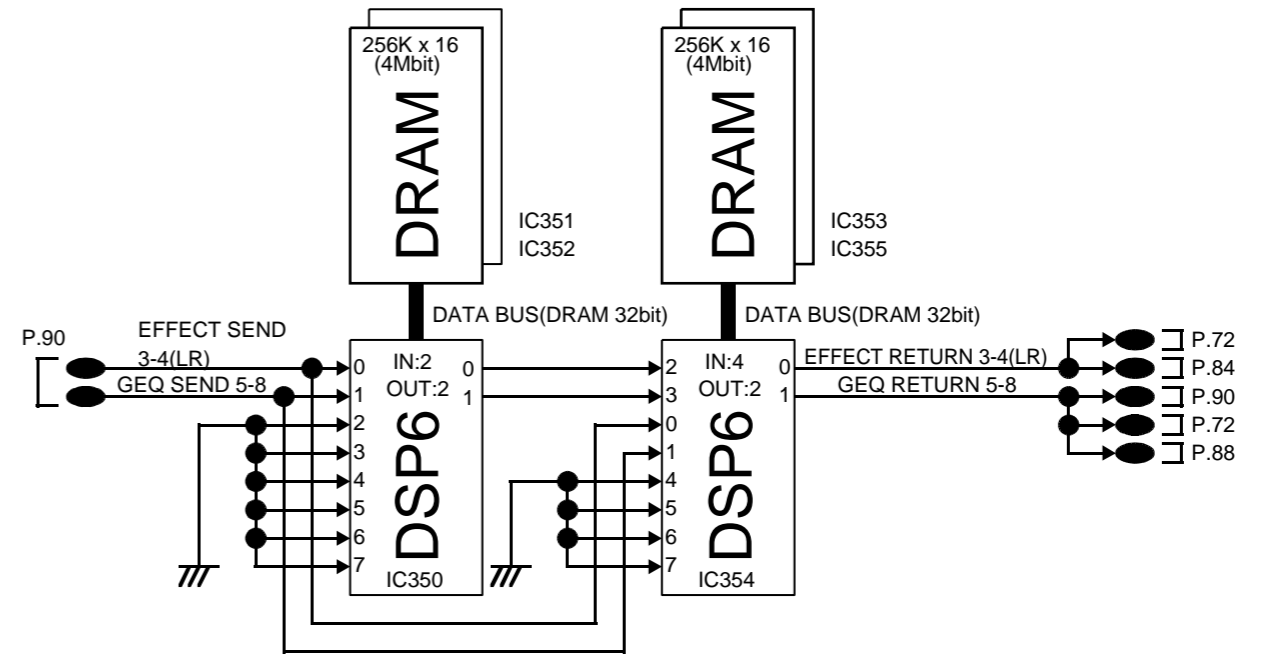
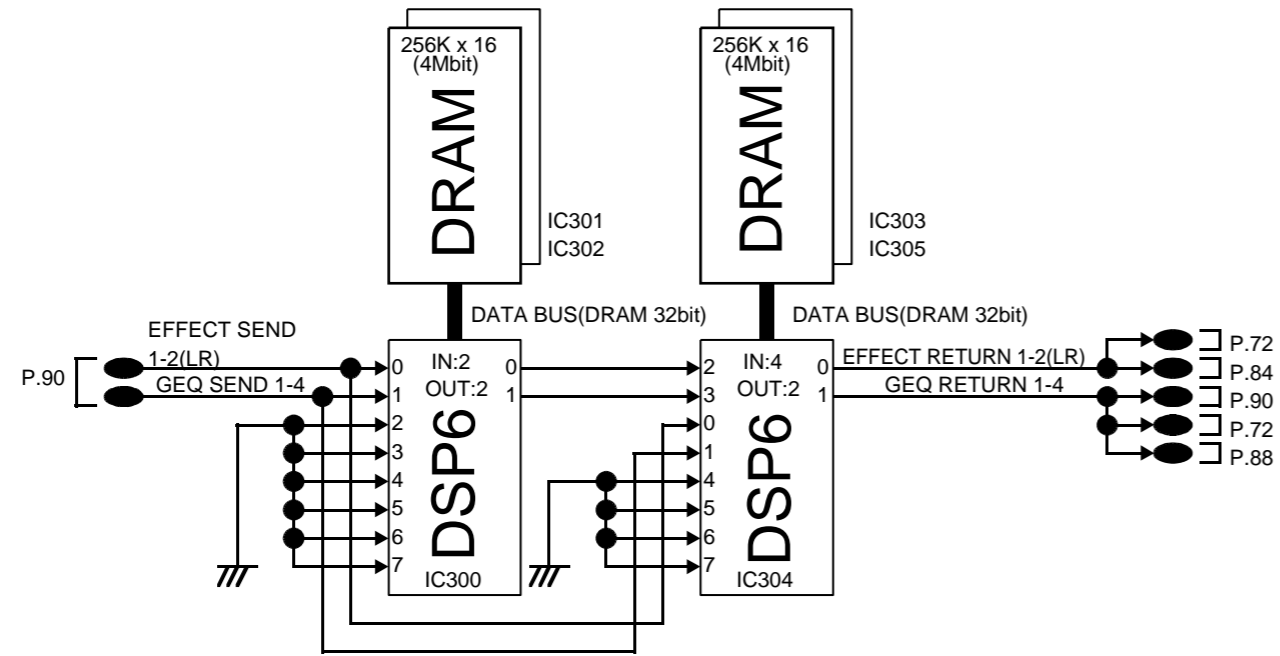

FUNCTION: EFFECT,GEQ

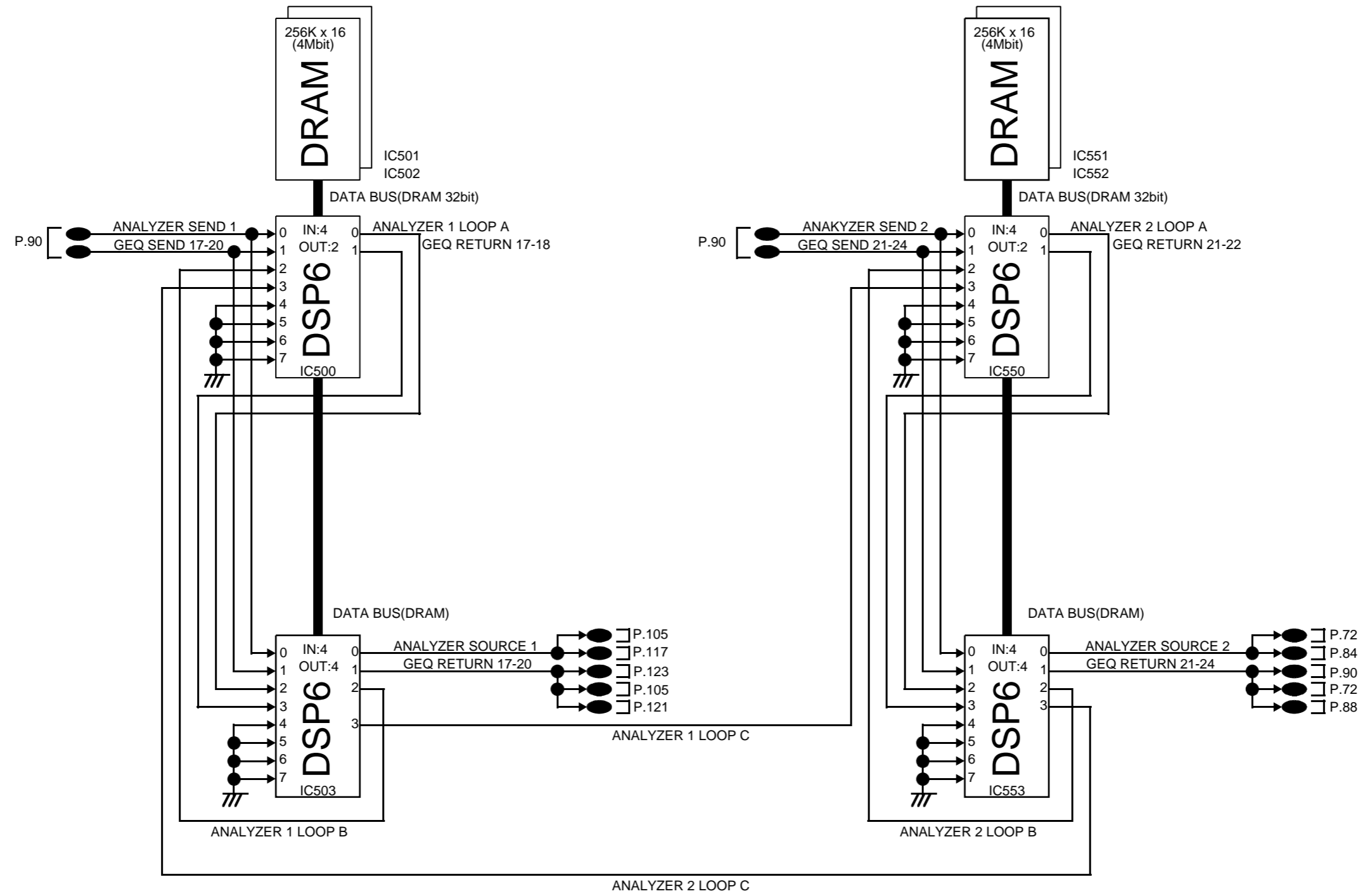

FUNCTION: EFFECT,GEQ