

● **Master Module: Group-to-Matrix Assigned Pre or Post Group Master Fader**

A slide switch in each master module permits the module's group send to the mix matrix to be altered. As shipped, the console is preset so that when the GROUP-TO-MTRX switch is on, the matrix is fed signal after the Group Master Fader (but before the GROUP ON/off switch). The internal switch in each of these modules can be repositioned so that the matrix is fed before the Group Master Fader.

In the factory preset configuration, the matrix follows the group mix. If one group, for example, is used for vocals, another for keyboards, etc., then all vocals going to all matrix outputs can be adjusted with one Group Master Fader... all Keyboards going to all matrix outputs can be adjusted with another Group Master Fader, etc. Suppose, however, that you plan to feed a

stereo house mix from the eight subgroups, yet you need as many as eight additional mono or five stereo mixes.

The mix matrix alone allows for only one stereo and six mono mixes, or a total of four stereo mixes. A greater number of mixes can be obtained by selecting the alternate (pre-Group Master Fader) switch positions. In that case, you can assign the Group Outputs to the stereo bus via the GROUP-TO-ST switch [40] and the adjacent PAN pot [41]; the Group Master Faders will serve as submasters for this stereo mix, and the Stereo Master Fader will control the mixed output. At the same time, the matrix controls on each master module will provide an 8:1 mix of the same groups; that matrix channel's #1 - #8 mix controls will serve as submasters, and the MTRX MASTER [31] will control the mixed output. (Do not turn up the L and R controls in the matrix, since these would be redundant here). In this way, you can obtain one stereo and eight mono mixes, five stereo mixes, or some combination thereof all with independent submaster and master controls.

● **GROUP MASTERモジュール**

GROUP TO MTRX信号POST FADER/PRE FADER

このスイッチにより、GROUP TO MTRX信号の取出し位置を、プリ・グループフェーダーにするか、ポスト・グループフェーダーにするかを選択することができます。出荷時はポスト・グループフェーダーにセットされています。

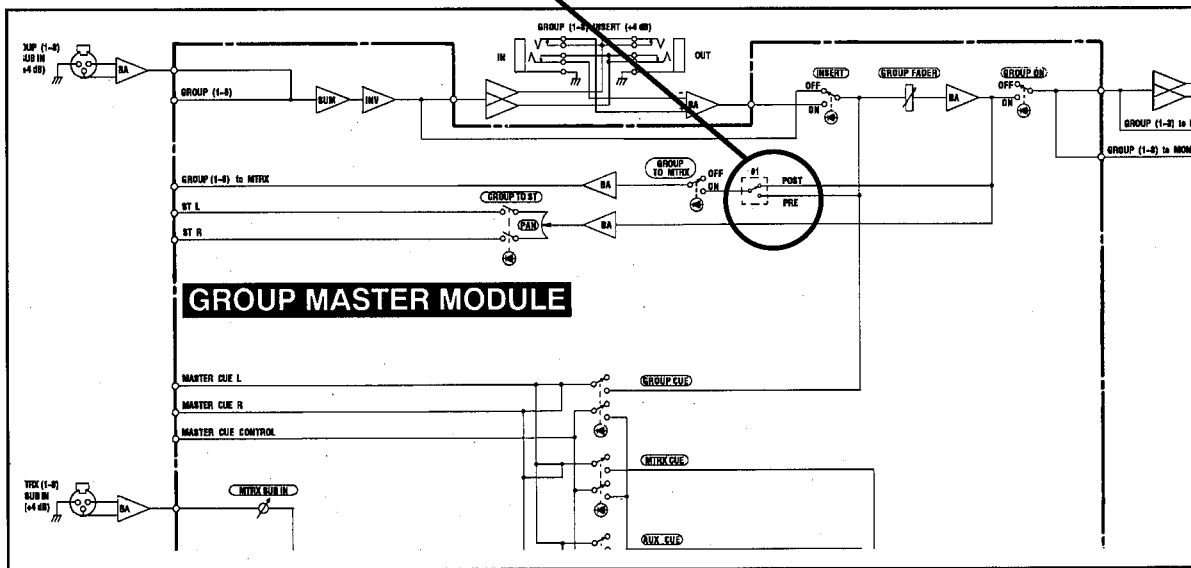
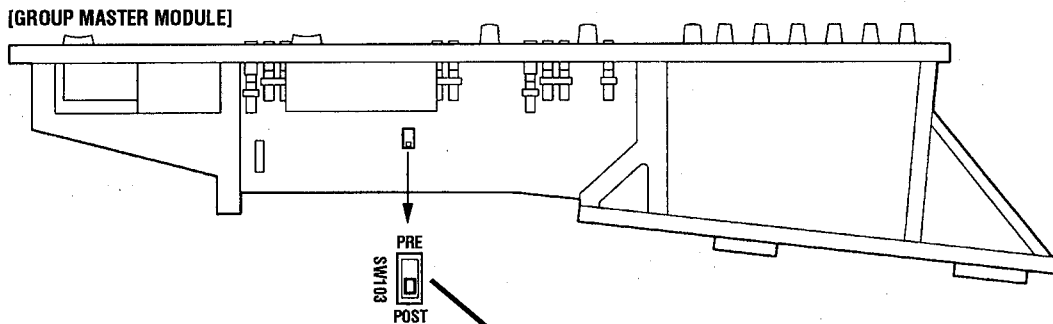

Internal Switch Position For Pre- and Post- Group Master Fader Feed to Mix Matrix, and Block Diagram Location.

PM4000/PW4000

● **Stereo Master to Matrix ST Bus:
Pre or Post ST Master Fader**

A slide switch in Stereo Master module enables the signal applied to the matrix stereo bus from that module to be derived from two different points. As shipped, the switch is preset so the matrix is fed its

signal after the Stereo Master fader [58] so that adjustments in the stereo output also affect the feed to the matrix. The internal switch can be repositioned so that the matrix is fed pre Stereo Master fader. In this way, the stereo output can be used for one feed, and it can be remixed in the matrix to create other stereo feeds.

● **STEREO MASTERモジュール**

ST TO MTRX 信号 POST FADER/PRE FADER

このスイッチにより、ST TO MTRX 信号の取出し位置を、プリ・ステレオマスターフェーダーにするか、ポスト・ステレオマスターフェーダーにするかを選択することができます。出荷時はポスト・ステレオマスターフェーダーにセットされています。

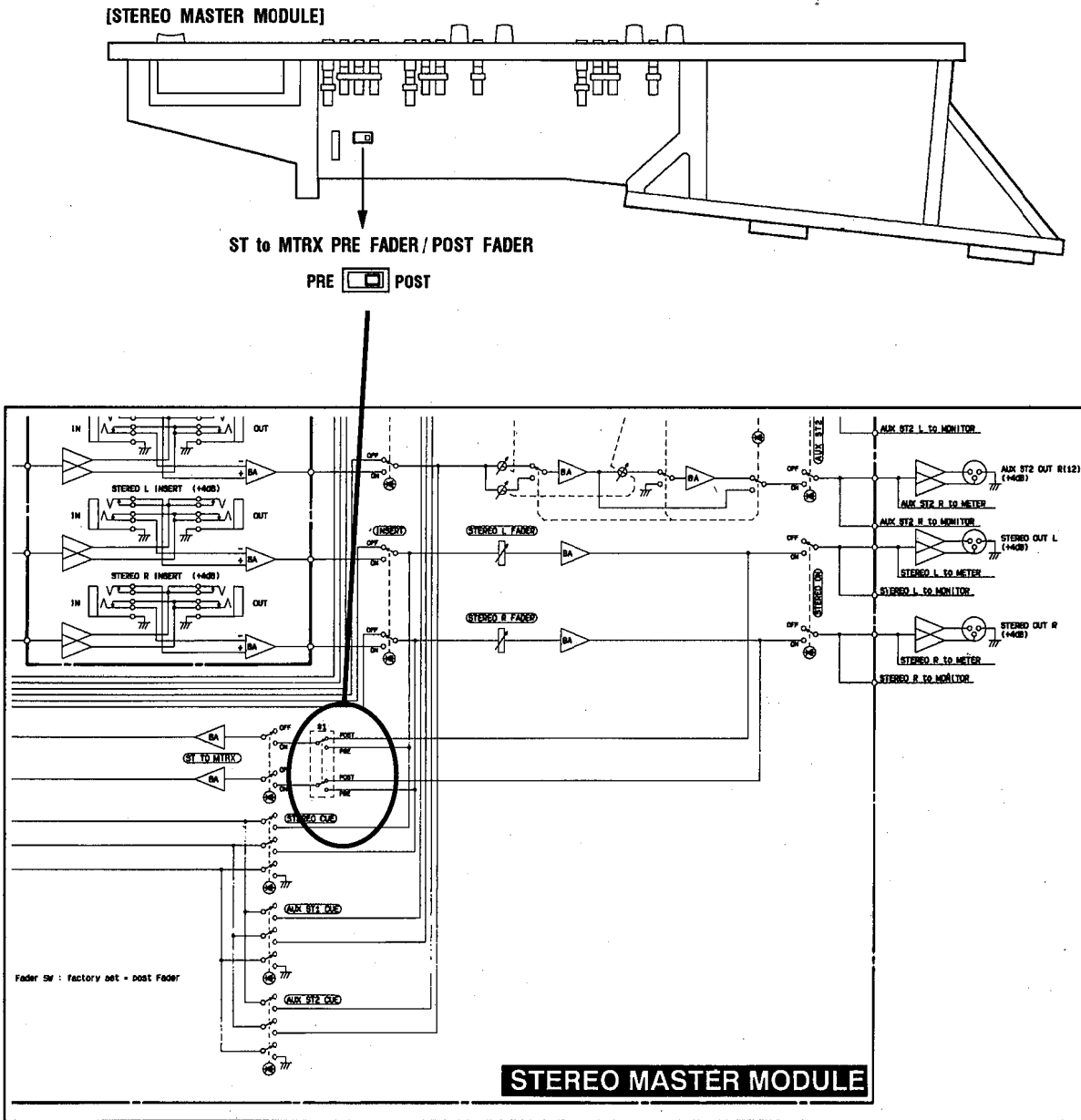

Internal Switch Positions For Pre- and Post- Stereo Master Fader Feeds to Mix Matrix, and Block Diagram Location.

PM4000/PW4000

• Installation of Optional Input Transformers

The PM4000 standard input module is equipped with a balanced, differential input preamplifier for the XLR connector. That preamp, along with some circuitry for the resistive attenuation pads, is located on a small printed circuit board that "piggy back" mounts to the module's main circuit board. Refer to Figure A.

The modification kit contains a replacement circuit board for the original differential preamplifier, and a separate input transformer. In order to install the kit, the following steps must be performed.

1. Shut off the power to the console.
2. Remove the Monaural (Stereo) input modules to be connected to input transformers.
3. Install the transformer onto the included fitting with the nut as shown in Figure B.
4. Being careful with the wiring, unfasten Angle H of the module by removing the two small flat head screws and the two small bind screws.

5. From the inside of Angle H, insert the two small M3 screws provided, and attach the transformer fitting. (Figure C)
6. Reset Angle H to its original position.
7. Pass all the wiring through the slit in Angle R.
8. Solder the transformer wiring to the new input transformer board. (Figure D)
9. Remove the present input transformer board, and replace with the new transformer board.
10. Reinstall the input module into the console mainframe.

The above completes the procedures for installation of an input transformer. Check the Fader and PAD signals to verify the installation. For a Stereo input module, up to 2 input transformers can be installed.

* Be careful that the wiring does not protrude from the module. Damage could result when the module is extracted.

Monaural: 1 transformer
Stereo: 2 transformers
(Procedure 3)

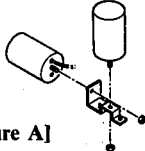

[Figure A]

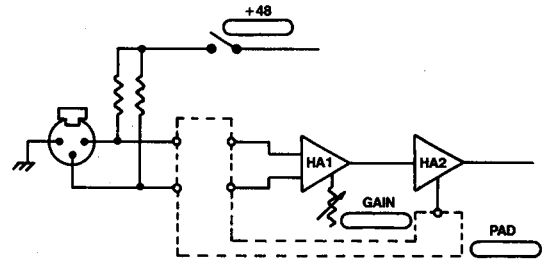

[Figure A] THIS PORTION OF CIRCUIT IS REPLACED WITH IT4000 TRANSFORMER

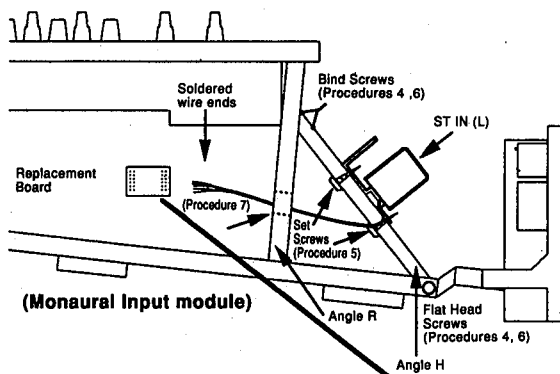

(Monaural Input module)

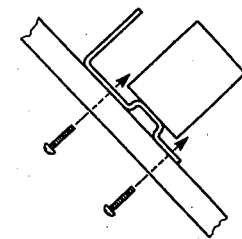

Enlargement (Procedure 5)

[Figure C]

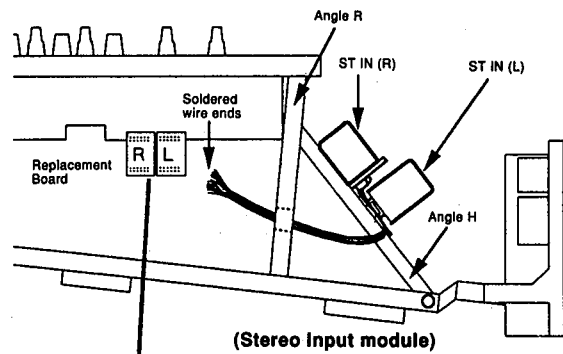

(Stereo Input module)

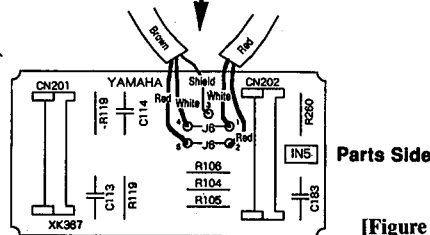

Parts Side

[Figure D]

Optional Input Transformer Installation

●入力トランス（オプション）の取り付け

PM4000のINPUTモジュールは電子バランスとなっています。通常使用状態において、アイソレーションに関する問題は何か心配することはありませんが、トランスフォーマーによるアイソレーションを希望する方のための、オプションとしてIT4000を用意しています。この改造キットには、交換用基板・入力トランスフォーマー・トランス金具・取り付け用ネジが入っています。キットの取り付けは、次の手順に従って行ってください。

手順③
モノラルは1個
ステレオは2個
取り付け

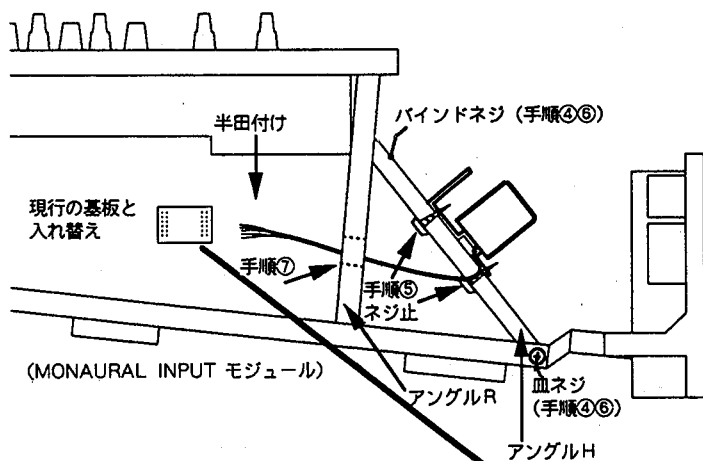
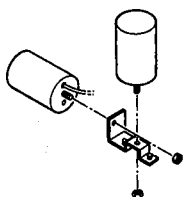

手順⑥拡大図

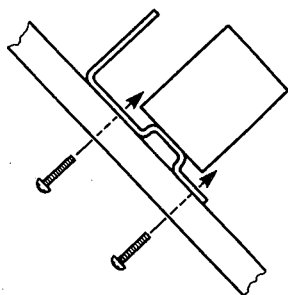

●入力トランスの取り付け位置

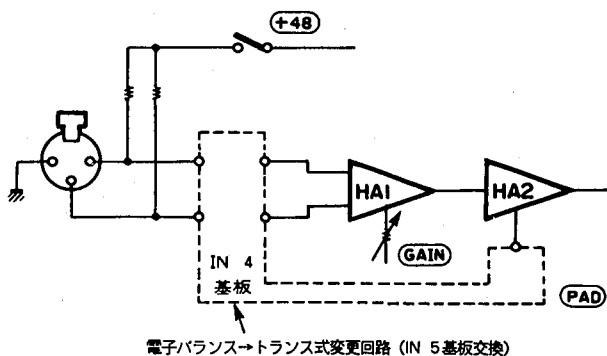

電子バランス→トランス式変更回路 (IN 5基板交換)
※トランス式に変更することにより入力インピーダンスが変わります。(62~64ページの“特性図”参照)
電子バランス=3kΩ
トランス入力=1kΩ

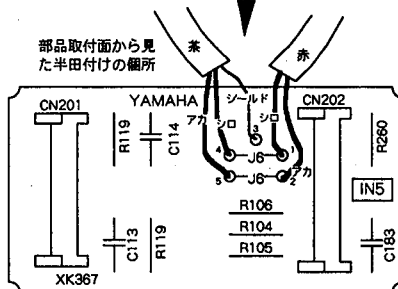
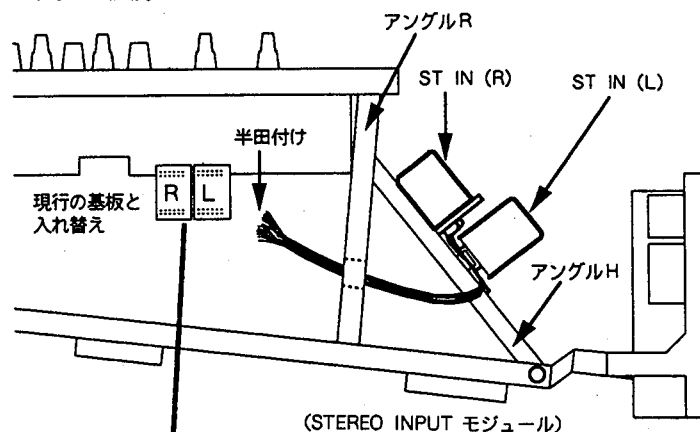

●取り付け手順

- ①コンソールの電源を切ります。
- ②入力トランスを取りつける MONAURAL/STEREO INPUT モジュールを取りはずします。
- ③IT4000に同梱のトランス金具にトランスをナットで取り付けます。
- ④モジュールのアングルHを外します。皿小ネジ2本、バインド小ネジ2本をはずす。
この時、リアパネルに通っている線材に気を付けて外してください。
- ⑤トランス金具の孔と、アングルHに設けられている2つの孔を合わせてアングルHの内側からM3小ネジ2本で取り付けます。次に、トランスの線材をアングルHの角孔に通します。
- ⑥アングルHを元通りに取り付けます。
- ⑦トランスの線材をモジュールのアングルRにあいているスリットに通します。

- ⑧IT4000に同梱の基板と、トランスの線材を半田付けします。半田付け位置は図を参照してください。
- ⑨現行基板を引き抜き取りはずし、その位置にトランス線に取り付けた新しい基板を差し替えます。

以上で取り付けは完了ですが、信号を入力して、位相やPADの機能を確認してください。STEREO INPUTモジュールにはIT4000入力トランスを2個取り付けることが可能です。その際2個目のIT4000に同梱のトランス金具は不要になります。

※モジュールの取りはずし・取り付けの際に断線の恐れがありますので、線材はモジュールの幅よりはみ出さないように処理してください。

IC BLOCK DIAGRAM (ICブロック図)

- **TC4006BP (IG001680)**
18-Stage Static Shift Register

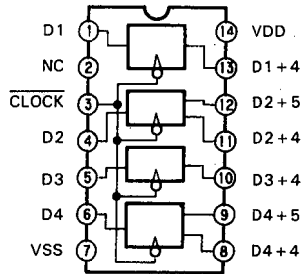

- **TC4030BP (IG001790)**
Quad Exclusive-OR Gate

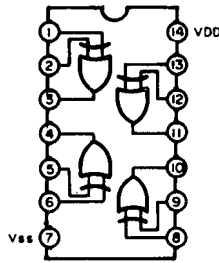

- **NJM2041D-D (IG069200)**
- **NE5532P (IG102500)**
- **NJM2904 (IG093700)**
Dual Operational Amplifier

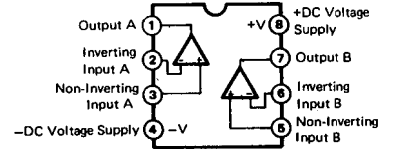

- **IR2E19 (IG136600)**
LED Driver

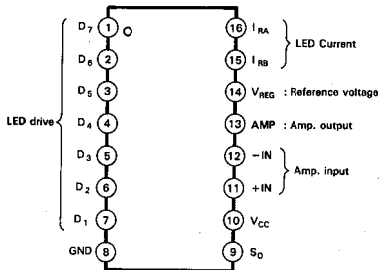

- **TC4052BP (XA053A00)**
Differential 4-Channel Multiplexer/Demultiplexer

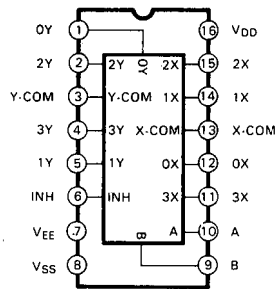

- **IR2E28 (XK259A00)**
LED Driver

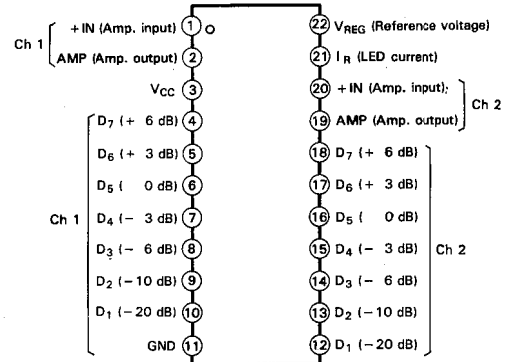

- **917090 (XK866A00)**
HA

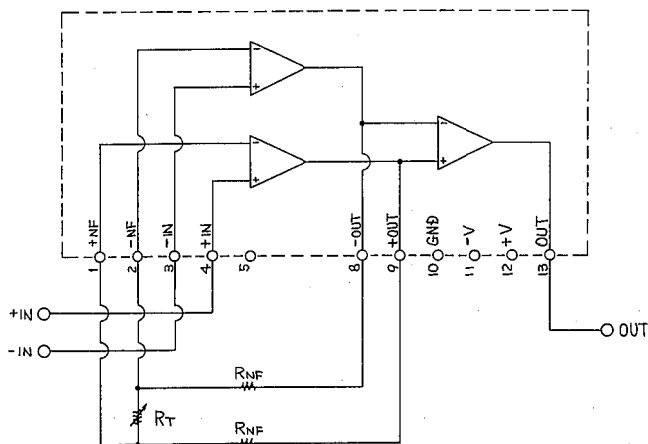

$$\text{GAIN} = 20 \times \log \left(1 + \frac{2 \times R_{NF}}{R_T} \right)$$

• 911308 (XK867B00)
PEQ

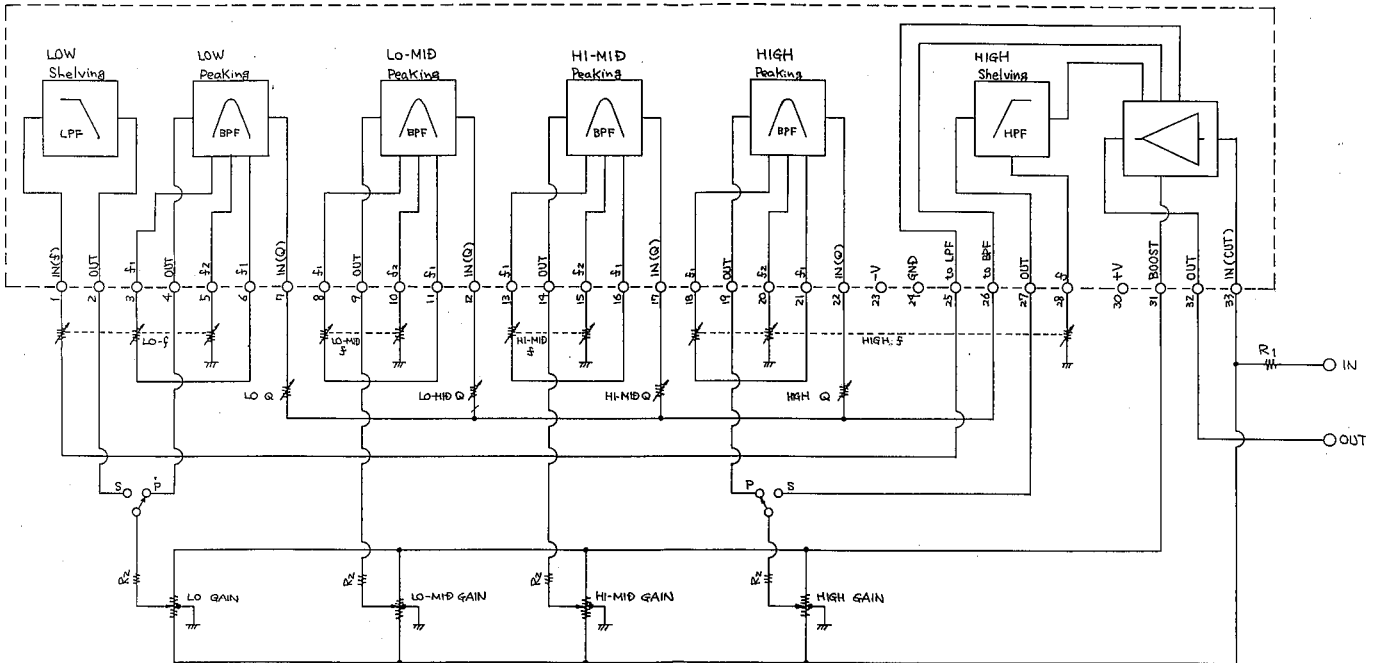

$$Q = (VR_Q[k\Omega] + 6.8)/20.4$$

$$EQ \text{ MAX GAIN} = 20 \times \log ((R_1 + R_2)/R_2)$$

$$EQ \text{ } f = 1/(2 \times \pi \times R \times C) \quad [R = 2700 + VR_f [\Omega], C = 0.1\mu, 0.036\mu, 0.0075\mu, 0.003\mu[F]$$

• 917089 (XK868C00)
VCA

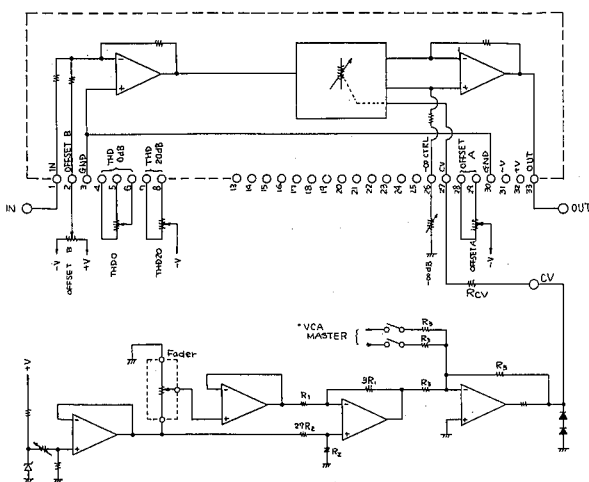

- (1) CV Fader MAX CV = -0.5 ± 0.01V
VCA GROUP SW all OFF
- (2) OFFSET
 - ① Fader MIN → OUT DC = V∞
 - * repeat ② Fader 0dB → OUT DC = V∞ ± 10mV (OFFSET A)
 - ③ Fader MAX
 - VCA GROUP 1 SW ON (VCA MASTER Fader MAX)
 - OUT DC = V∞ ± 10mV (OFFSET B)
- (3) THD IN 0dB 1kHz INPUT
 - * repeat ① Fader 0dB → THD ≤ 0.01% < MIN > (THD 0)
 - ② Fader MAX
 - VCA GROUP 1 SW ON (VCA MASTER Fader MAX)
 - THD ≤ 0.01% < MIN > (THD 20)
- (4) -∞dB IN +20dB 1kHz INPUT
 - ① Fader MIN → OUT AC ≤ -90dB (-∞dB)

VCA GAIN	Rcv = 5K	-20dB/V
	∴ CV = -1V	+20dB
	CV = 0V	0dB
	CV = +1V	-20dB

• 917038 (XK870A00)
EBI

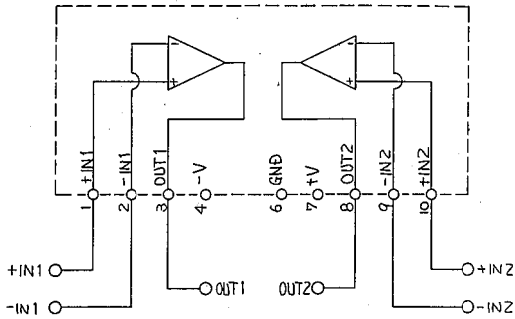

GAIN = -4.1dB

• 917040 (XK871A00)
EBO

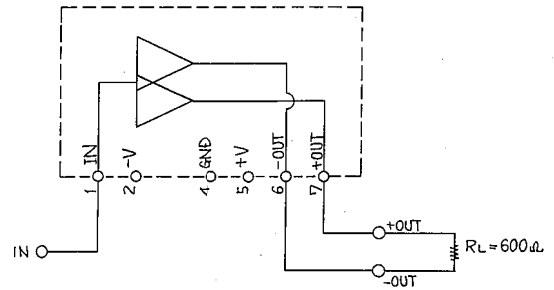

GAIN (Bal : $R_L = 600$) = 4.3dB
 GAIN (-OUT short : $R_L = 600$) = 3.9dB
 GAIN (+OUT short : $R_L = 600$) = 4.0dB

* $R_L = 10K$
 GAIN (Bal) = 5.3dB
 GAIN (-OUT short) = 4.8dB
 GAIN (+OUT short) = 4.9dB

• 911306 (XK872A00)
INS

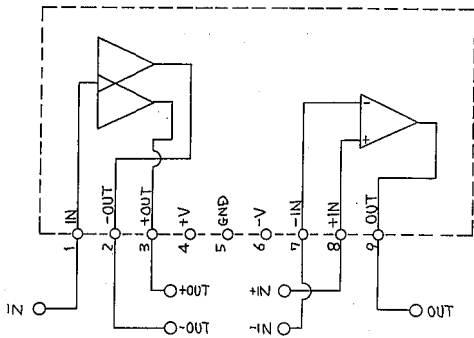

(1) IN → +OUT
 -OUT

GAIN (Bal : $R_L = 10K$) = 4.3dB
 (-OUT short : $R_L = 10K$) = 3.9dB
 (+OUT short : $R_L = 10K$) = 3.9dB

(2) +IN → OUT
 -IN

GAIN = -4.1dB

(3) IN → OUT
 GAIN = 0.2dB

• 917037 (XK873A00)
BA

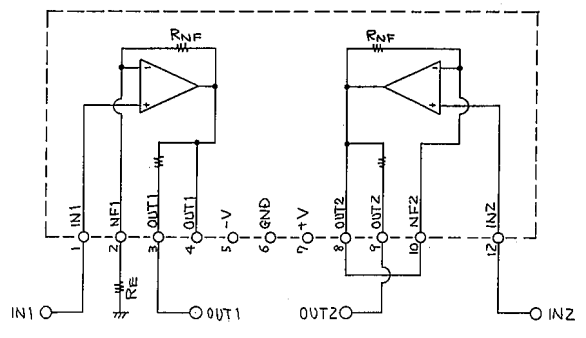

(1) IN1 → OUT1

$$GAIN = 20 \times \log \left(1 + \frac{R_{NF}}{R_E} \right)$$

$$\therefore R_{NF} = 11K$$

$$GAIN = 20 \times \log (1 + 11K/RE)$$

(2) IN2 → OUT2

0dB Buffer Amp

- **SN74HC563N (IR0563500)**
Octal 3-State D-Latches (Inverted)

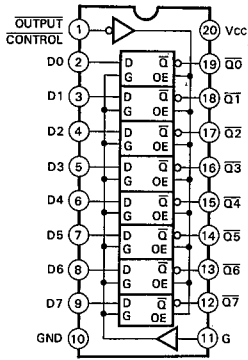

- **SN74HC573N (IR0573500)**
Octal 3-State D-Latches

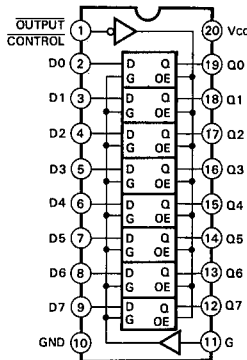

- **NJU9202BD (XK882A00)**
LED Drive, Analog to Digital Converter

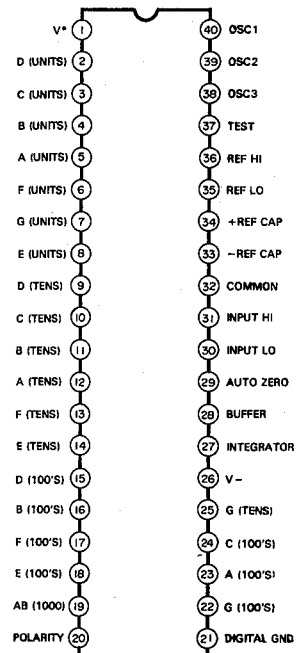

- **SN74HC08N (IR000850)**
Quad 2 Input AND

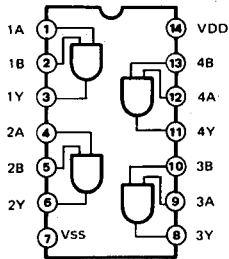

- **SN74HC14N (IR001450)**
Hex Inverter

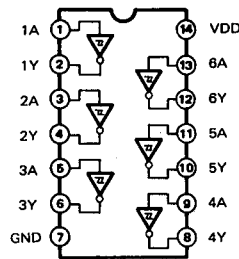

- **SN74HC21N (IR002150)**
Dual 4 Input AND

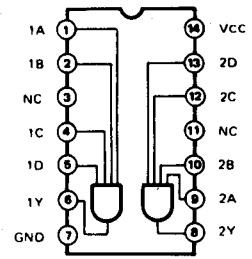

- **917091 (XK869A00)**
SUM

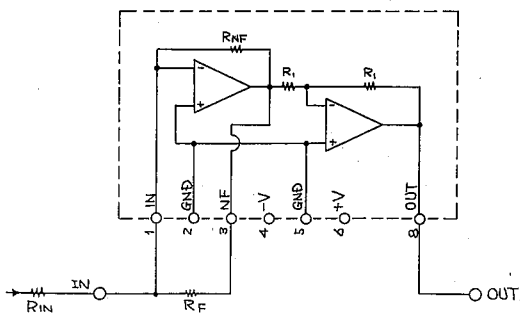

$$\text{GAIN} = 20 \times \log \left(\frac{R_{NF}}{R_{IN} \times \left(1 + \frac{R_{NF}}{R_F} \right)} \right)$$

$$\therefore R_{NF} = 56K$$

$$\text{GAIN} = 20 \times \log \left(\frac{56K}{R_{IN}(1 + 56K/R_F)} \right)$$

$$\ast R_F = \infty$$

$$\text{GAIN} = 20 \times \log (56K/R_{IN})$$

■ PM4000 INSPECTIONS

1. PREPARATIONS

- 1) Connect the PM4000 and a PW4000 via the supplied DC power supply cable.
- 2) Unless specified, an applied signal should be a sine wave of 1 kHz, -80 dBs and the impedance of the signal source should be 150 ohms.

The load resistance of each output terminal should be as follows:

PHONES (L, R) 8 ohms (greater than 5 W)
 All INSERT OUT 10 kohms
 Other outputs 600 ohms

- 3) The signal level referred to in this specifications is 0 dBs = 0.775 V.

- 4) Unless specified, controls and switches must be set as follows:

• CH INPUT (1-24, 32, 40, 48)

ASSIGN switch ON during measurement only, OFF at all other times.
 PAN switch OFF
 +48V switch OFF
 PAN control CENTER
 GAIN trim MAX (-70 dB)
 PAD (30dB) switch OFF
 ϕ switch OFF (Positive phase)

EQ (HI, HI-MID, LO-MID, LO)

LEVEL control CENTER
 FREQ control MIN
 Q control CENTER
 ON switch OFF

(HI, LO)

SHELF switch OFF (PEAK)
 HPF FREQ control MIN
 HPF switch OFF
 INSERT ON switch ON during measurement only, OFF at all other times.
 INSERT PRE switch OFF (POST)

AUX 1-8

LEVEL control MAX
 PRE/OFF/POST switch PRE or POST during measurement only, OFF at all other times.

AUX ST 1, 2

LEVEL (LEVEL L) control MAX
 PAN (LEVEL R) control CENTER
 PRE/OFF/POST switch PRE or POST during measurement only, OFF at all other times.
 LEVEL/PAN switch PAN

METER PRE switch OFF (POST)

ON switch ON for measuring CH only, OFF for all others.

VCA GROUP (1-8) switch OFF

MUTE GROUP (1-8) switch OFF

MUTE SAFE switch OFF

CUE/SOLO switch ON for measuring CH only, OFF for all others.

Fader MAX

- STEREO INPUT (1, 2)
 - ASSIGN switch ON during measurement only, OFF at all other times.
 - PAN switch OFF
 - +48V switch OFF
 - PAN control CENTER
 - INPUT SELECTOR switch ST
 - GAIN trim MAX (-70dB)
 - PAD (30dB) switch OFF
 - § switch OFF (Negative phase)
 - EQ (HI, HI-MID, LO-MID, LO)
 - LEVEL control CENTER
 - FREQ control MIN
 - Q control CENTER
 - ON switch OFF
 - (HI, LO)
 - SHELF switch OFF (PEAK)
 - HPF FREQ control MIN
 - HPF switch OFF
 - INSERT ON switch ON during measurement only, OFF at all other times.
 - AUX 1-8
 - LEVEL control MAX
 - PRE/OFF/POST switch PRE or POST during measurement only, OFF at all other times.
 - AUX ST 1,2
 - LEVEL (LEVEL L) control MAX
 - BAL PAN (LEVEL R) control CENTER
 - PRE/OFF/POST PRE or POST during measurement only, OFF at all other times.
 - LEVEL/BAL PAN switch BAL PAN
 - METER PRE switch OFF (POST)
 - ON switch ON for measuring CH only, OFF for all others.
 - VCA GROUP (1-8) switch OFF
 - MUTE GROUP (1-8) switch OFF
 - MUTE SAFE switch OFF
 - CUE/SOLO switch ON for measuring CH only, OFF for all others.
 - Fader MAX
- MASTER
 - GROUP (1-8)
 - PAN control CENTER
 - GROUP TO ST switch ON during measurement only, OFF at all other times.
 - GROUP TO MATRIX switch ON during measurement only, OFF at all other times.
 - INSERT switch ON during measurement only, OFF at all other times.
 - CUE switch ON during measurement only, OFF at all other times.
 - ON switch ON during measurement only, OFF at all other times.
 - Fader MAX
 - STEREO
 - ST TO MATRIX switch ON during measurement only, OFF at all other times.
 - INSERT switch ON during measurement only, OFF at all other times.
 - CUE switch ON during measurement only, OFF at all other times.
 - ON switch ON during measurement only, OFF at all other times.
 - L Fader MAX
 - R Fader MAX

MATRIX

- SUB IN control ON during measurement only, OFF at all other times.
- MATRIX MIX control MAX during measurement only, MIN at all other times.
- MASTER control MAX
- INSERT switch ON during measurement only, OFF at all other times.
- ON switch ON during measurement only, OFF at all other times.

AUX

- LEVEL control MAX
- INSERT switch ON during measurement only, OFF at all other times.
- ON switch ON during measurement only, OFF at all other times.

AUX ST (1, 2)

- BAL (LEVEL R) control CENTER
- LEVEL switch OFF
- LEVEL (LEVEL L) control MAX
- INSERT switch ON during measurement only, OFF at all other times.
- CUE switch ON during measurement only, OFF at all other times.
- ON switch ON during measurement only, OFF at all other times.

MONITOR A

- SELECT switch ON during measurement only, OFF at all other times.
- LEVEL control MAX
- MONO switch OFF
- ON switch ON during measurement only, OFF at all other times.
- PHONES control MAX

MONITOR B

- SELECT switch ON during measurement only, OFF at all other times.
- LEVEL control MAX
- ON switch ON during measurement only, OFF at all other times.

TALKBACK

- ASSIGN switch ON during measurement only, OFF at all other times.
- OUT switch ON during measurement only, OFF at all other times.
- OSC OUT switch OFF
- OSC switch OFF
- OSC FREQ control MIN
- SWEEP switch OFF
- OSC LEVEL control MAX
- +48V switch OFF
- +4dB switch OFF (-50 dB)
- TB LEVEL control MAX
- ON/OFF/ON switch ON during measurement only, OFF at all other times.

Others

- VCA MASTER Fader (1-8) MAX
- VCA MUTE (1-8) switch ON during measurement only, OFF at all other times.
- MUTE MASTER (1-8) switch ON during measurement only, OFF at all other times.
- METER SELECT switch 1 : G, 2 : A
- MON.A switch (24, 32 only) OFF
- SOLO switch OFF
- PHANTOM MASTER switch OFF
- VCA CONTROL switch (1-4) OFF
- VCA CONTROL switch (5-8) OFF
- MUTE CONTROL switch (1-4) OFF
- MUTE CONTROL switch (5-8) OFF
- CUE SOLO CONTROL switch OFF
- FAN LOW/HIGH switch LOW

2. GAIN

In status 1, the output level should be within the range given in Tables 2-1 to 2-7.

Table 2-1 Input Terminal [INPUT CH 1 to 24, 32, 40, 48] Units: dBs

INPUT LEVEL	GAIN VR	30dB PAD	INSERT OUT	DIRECT OUT	GROUP OUT (1-8)	STEREO OUT(L, R)	MONI A OUT (L, R)
-80	MAX	OFF	-6±2	+4±2	+14±2	+14±2	+4±2 *2
-50	MAX	ON	—	—	+14±2 *1	—	—
-30	MIN	OFF	—	—	+14±2 *1	—	—

*1 Measuring can be performed at either one of the output terminals of GROUP OUT (1 to 8).

*2 CUE switch should be turned ON.

The difference in level between INPUT (CH 1 to 24, 32, 40, 48) of each output should be less than 2 dB. The difference in level between GROUP OUT (1 to 8), STEREO OUT (L,R), and MONI A OUT (L,R) should be less than 2 dB.

Table 2-2 Input Terminal [INPUT CH 1 to 24, 32, 40, 48] Units: dBs

INPUT LEVEL	GAIN VR	30dB PAD	AUX & AUX ST	AUX ST (1, 2)		AUX OUT (1-8)	AUX ST (1, 2) OUT (L, R)
				CH	MASTER		
			PRE/OFF POST SW	LEVEL/PAN SW	LEVEL SW		
-30	MIN	OFF	PRE	PAN	OFF	+10±2	+7±2
-30	MIN	OFF	POST	PAN	OFF	+20±2 *1	+17±2 *1
-30	MIN	OFF	PRE	LEVEL	ON	—	+10±2 *2

*1 Measuring can be performed at either one of the output terminals of AUX OUT (1 to 8) and one of AUX ST OUT (1, 2), (L, R).

*2 Maximize the channel PAN R and MASTER BAL R controls.

The difference in level between AUX OUT (1 to 8), AUX ST OUT (1, 2), (L, R) should be less than 2 dB.

Table 2-3 Input Terminal [ST-INPUT 1 to 4 (L, R)] *1 Units: dBs

INPUT LEVEL	GAIN VR	30dB PAD	SELECT SW	INSERT OUT	GROUP OUT (1-8)	STEREO OUT (L, R)	MONI A OUT (L, R)
-80	MAX	OFF	ST	-6±2	+14±2	+14±2	+4±2
-50	MAX	ON	ST	—	+14±2 *2	—	—
-30	MIN	OFF	ST	—	+14±2 *2	—	—
-30	MIN	OFF	L	—	+14±2 *3	—	—
-30	MIN	OFF	R	—	+14±2 *4	—	—
-30	MIN	OFF	L+R	—	+17±2 *5	—	—

*1 Apply a signal to stereo L input when outputs are obtained at 1, 3, 5, 7, L.

When outputs are obtained at 2, 4, 6, 8, R, apply a signal to stereo R input.

*2 Measure at GROUP OUT (1, 2).

*3 Apply a signal to stereo L input and measure at GROUP OUT (1).

*4 Apply a signal to stereo R input and measure at GROUP OUT (1).

*5 Apply same signals to stereo L and R inputs and measure at GROUP OUT (1).

The difference in level between ST-INPUT (1, 2), (L, R) and INPUT (CH 1 to 24, 32, 40, 48) should be less than 2 dB.

The difference in level between GROUP OUT(1 to 8), AUX OUT (1 to 8), STEREO OUT (L, R) and MONI A OUT (L, R) should be less than 2 dB.

Table 2-4 Input Terminal [ST-INPUT 1 to 4 (L, R)] *1

Units: dBs

INPUT LEVEL	SELECT SW	GAIN VR	30dB PAD	AUX & AUX ST	AUX ST ST-IN	AUX OUT (1-8)	AUX ST (1, 2) OUT (L, R)
				PRE/OFF POST SW	LEVEL/BAL SW		
-40	ST	MIN	OFF	PRE	BAL PAN	+3±2	-3±2
-40	ST	MIN	OFF	POST	BAL PAN	+13±2 *2	+7±2 *2
-40	ST	MIN	OFF	PRE	LEVEL	—	0±2 *3
-40	L	MIN	OFF	PRE	LEVEL	0±2 *1	0±2 *1*3

*1 Apply same signals to stereo L and R inputs.

*2 Measuring can be performed at either one of the output terminals of AUX OUT (1 to 8) and one of AUX ST OUT (1, 2), (L, R).

*3 Maximize the channel PAN/LEVEL R and MASTER BAL/LEVEL R controls.

The difference in level between AUX OUT (1 to 8), AUX ST OUT (1, 2), (L, R) should be less than 2 dB.

Table 2-5 Input Terminal [TB IN]

Units: dBs

INPUT TERMINAL	INPUT LEVEL	GROUP OUT (1-8)	STEREO OUT (L, R)	AUX OUT (1-8)	AUX ST (1-2) (L, R)	MON.B (L, R)	TB OUT
TB IN	-60	+14±2	+14±2	+14±2	+14±2	+14±2 *1	+4±2

*1 TB to MONI B switch should be turned ON.

The difference in output levels between each output should be less than 2 dB.

Table 2-6 Output Terminal [MONITOR A]

Units: dBs

INPUT TERMINAL	SELECT SW	INPUT LEVEL	OUTPUT TERMINAL	OUTPUT LEVEL
2TR IN 1 (L, R)	2TR IN 1	+4.0	MONITOR A (L, R)	+14±2 *2
2TR IN 2 (L, R)	2TR IN 2	+4.0	MONITOR A (L, R)	+14±2 *2
ST CH3 (L, R) *1	ST CH3	-30.0	MONITOR A (L, R)	+14±2 *2
ST CH4 (L, R) *1	ST CH4	-30.0	MONITOR A (L, R)	+14±2 *2
STEREO SUB IN	ST OUT	-6.0	MONITOR A (L, R)	+14±2 *2
AUX ST1 SUB IN	AUX ST1	-6.0	MONITOR A (L, R)	+14±2 *2
AUX ST2 SUB IN	AUX ST2	-6.0	MONITOR A (L, R)	+14±2 *2
AUX (1-8) SUB IN	AUX (1-2~7-8) *3	-6.0	MONITOR A (L, R)	+14±2 *2
GROUP (1-8) SUB IN	GROUP (1-2~7-8) *3	-6.0	MONITOR A (L, R)	+14±2 *2
MATRIX (1-8) SUB IN	MATRIX (1-2~7-8) *3	+4.0	MONITOR A (L, R)	+14±2 *2
STEREO SUB IN	(ST CUE ON)	+4.0	MONITOR A (L, R)	+14±2 *2

*1 Minimize the GAIN control and turn PAD to off.

*2 At this time, turn on the MONO switch, and confirm that the output level should be -3 dB, with the level when MONO is off as the reference.

When same signals are applied to the L and R inputs, the output level should be +3 dB, with the level when MONO is off as the reference.

*3 Do not simultaneously turn on two or more switches of '1-2' to '7-8'.

*4 When TB and TB to MON.B swiches are simultaneously turned on, output levels given in Table 2-6 should be -7 ± 1 dB, with the level when two switches are off as the reference. (Measuring should be performed in one of the conditions described above.)

The difference in levels between L and R outputs should be less than 2 dB.

Table 2-7 Output Terminal [MONITOR B]

Units: dBs

INPUT TERMINAL	SELECT SW	INPUT LEVEL	OUTPUT TERMINAL	OUTPUT LEVEL
2TR IN 1 (L, R)	2TR IN 1	+4.0	MONITOR B (L, R)	+14±2
2TR IN 2 (L, R)	2TR IN 2	+4.0	MONITOR B (L, R)	+14±2
ST CH3 (L, R) *1	ST CH3	-30.0	MONITOR B (L, R)	+14±2
ST CH4 (L, R) *1	ST CH4	-30.0	MONITOR B (L, R)	+14±2
ST SUB IN	ST OUT	-6.0	MONITOR B (L, R)	+14±2
—	MON A *2	—	MONITOR B (L, R)	+14±2
TB IN	TB TO MON B *3	-6.0	MONITOR B (L, R)	+14±2

*1 Minimize the GAIN control and turn PAD to off.

*2 Set the level of MONITOR A within one of the range given in Table 2-6.

*3 The output can be obtained only when the TB and TB to MON.B switches are simultaneously turned on.

Measuring can be performed when +4 switch of TB IN is turned on.

The difference in level between L and R outputs should be less than 2 dB.

Table 2-8 Input Terminal [INSERT]

Units: dBs

INPUT TERMINAL	INPUT LEVEL	GROUP OUT (1-8)	STEREO OUT (L, R)	AUX OUT (1-8)	AUXST1, 2 OUT (L, R)	MATRIX OUT (1-8)
CH (1-24, 32, 40, 48)	-6	+14±2 *1	—	—	—	—
ST-IN (1-4) (L, R)	-6	+14±2 *2	—	—	—	—
GROUP (1-8)	+4	+14±2	—	—	—	—
STEREO (L, R)	+4	—	+14±2	—	—	—
AUX (1-8)	+4	—	—	+14±2	—	—
AUX ST (1, 2) (L, R)	+4	—	—	—	+14±2	—
MATRIX (1-8)	+4	—	—	—	—	+4±2

*1 Measuring can be performed at either one of the output terminals of GROUP OUT (1 to 8).

*2 Measuring can be performed at either two of the output terminals (odd, even) of GROUP OUT (1 to 8).

The difference in level between INPUT (CH 1 to 24, 32, 40, 48) of each output should be less than 2 dB.

The difference in level between ST-INPUT (CH 1 to 4), (L, R) should be less than 2 dB.

The difference in level between GROUP OUT (1 to 8), STEREO OUT (L,R), AUX OUT (1 to 8), AUX ST (1, 2), (L, R) and MTRX OUT (1 to 8) should be less than 2 dB.

Table 2-9 Input Terminal [SUBIN]

Units: dBs

INPUT TERMINAL	INPUT LEVEL	GROUP OUT (1-8)	STEREO OUT (L, R)	AUXOUT (1-8)	AUXST1, 2 OUT (L, R)	MATRIX OUT (1-8)	MONI A (L, R)
GROUP (1-8)	+4	+14±2	—	—	—	—	—
STEREO (L, R)	+4	—	+14±2	—	—	—	—
AUX (1-8)	+4	—	—	+14±2	—	—	—
AUXST1, 2 (L, R)	+4	—	—	—	+14±2	—	—
MATRIX (1-8)	+4	—	—	—	—	+4±2	—
CUE (L, R) *1	+4	—	—	—	—	—	+14±2

*1 Either one of the CUE switches should be turned ON.

The output level of $+4 \pm 2$ dBs can be obtained at each INSERT OUT.
 The difference in level between GROUP OUT (1 to 8), STEREO OUT (L,R), AUX OUT (1 to 8), AUX ST (1, 2), (L, R), MTRX OUT (1 to 8) and CUE (L, R) should be less than 2 dB.

Table 2-10

MONI A OUT (L, R)	PHONES (L, R)
+4 dBs	0 ± 2 dBs

The PHONES output given in Table 2-10 should be obtained when the output level of MONI A OUTPUT is +4 dBs.

The difference in level between PHONES L and R outputs should be less than 2 dB.

3. FREQUENCY CHARACTERISTICS

If the applied signal frequencies are 20 Hz, 20 kHz in status 1, the output level of each output terminal should be within $0 +1/-3$ dB with the level at 1 kHz used as reference.

When the applied signal frequency is 20 Hz, the PHONES output level should be within -2 ± 2 dB.

4. EQ CHANGE CHARACTERISTICS

When the EQ controls of CH-INPUT and ST-INPUT are operated in status 1, the output level of each frequency obtained in GROUP OUT (1) should fall within the range given in Table 4-1 to Table 4-4, with the output level when the control is set as a reference in the middle.

If an output level is more or less than the rated range, vary the frequency of the applying signal within ± 20 %. If this output level is within the rated value given in Tables, then it is acceptable.

When a signal is applied to stereo R input, measure at GROUP OUT (2).

Table 4-1 [HI] Units: dB

GAIN	FREQ	Q	SHELF	1kHz	5kHz	20kHz
MIN	MIN	MIN	OFF	-15 ± 2	—	—
MAX	MAX	MIN	OFF	—	$+1 \pm 2$	$+15 \pm 2$
MAX	MAX	MIN	ON	—	—	$+12 \pm 2$
MAX	MAX	MAX	OFF	—	$+10 \pm 2$	—

Table 4-2 [HI-MID] Units: dB

GAIN	FREQ	Q	400Hz	2kHz	8kHz
MIN	MIN	MIN	-15 ± 2	—	—
MAX	MAX	MIN	—	$+1 \pm 2$	$+15 \pm 2$
MAX	MAX	MAX	—	$+10 \pm 2$	$+15 \pm 2$

Table 4-3 [LO-MID] Units: dB

GAIN	FREQ	Q	80Hz	400Hz	1.6kHz
MIN	MIN	MIN	-15 ± 2	—	—
MAX	MAX	MIN	—	$+1 \pm 2$	$+15 \pm 2$
MAX	MAX	MAX	—	$+10 \pm 2$	$+15 \pm 2$

Table 4-3 [LO] Units: dB

GAIN	FREQ	Q	SHELF	30Hz	160Hz	600Hz
MIN	MIN	MIN	OFF	-15 ± 2	—	—
MAX	MAX	MIN	OFF	—	$+1 \pm 2$	$+15 \pm 2$
MAX	MAX	MIN	ON	—	—	$+12 \pm 2$
MAX	MAX	MAX	OFF	—	$+10 \pm 2$	$+15 \pm 2$

5. HPF CHANGE CHARACTERISTICS

In status 1, if the HPF switches of CH-INPUT are switched on and HPF-f controls in CH-INPUT and ST-INPUT are operated, the output level of GROUP OUT (1) should be within the range given in Table 5, with the level when HPF is off as the reference.

Table 5

HPF FREQ	20Hz	400Hz
MIN	-3 ± 2	—
MAX	—	-3 ± 2

When a signal is applied to stereo R input, measure at GROUP OUT (2).

6. SEPARATION

In status 1, if the PAN and assign 1-2 switch of the measured CH-INPUT and ST-INPUT are switched on and PAN control is rotated fully counterclockwise and the output level of GROUP OUT (1) is set at +20 dBs, the leakage level to GROUP OUT (2) should be less than -50 dBs.

Also, if the PAN control is rotated fully clockwise and if the output level of GROUP OUT (2) is set at +20 dBs, the leakage level to GROUP OUT (1) should be less than -50 dBs.

Inspection of leakage between STEREO OUT L-R can be performed in a similar manner.

Apply same signals to stereo R and L inputs when measuring ST-INPUT.

7. VCA MUTING

In status 1, apply a signal of -50 dBs to each input terminal of INPUT (CH 1 to 24, 32, 40, 48) and minimize the FADER controls, and confirm that the output level of each DIRECT OUT should be less than -75 dBs.

Also, apply a signal of -50 dBs to ST-INPUT (L, R) and minimize the FADER controls, the output levels of GROUP OUT (1, 2) should be less than -63 dBs.

Inspection of leakage between STEREO OUT L-R can be performed in a similar manner.

When a signal is applied to stereo L input, measure at GROUP OUT (1).

When applied to stereo R input, measuring can be performed at GROUP OUT (2).

8. PEAK LED LIGHT-UP LEVEL (METER)

When the MT PRE switches are turned on and signals have been applied to each of CH-INPUT and ST-INPUT in status 1, each LED of channel level meter should light up within the range given in Table 8.

Table 8

INSERT OUT	-20	-10	-6	0	6	PEAK
INPUT LEVEL	-16 ± 2	-6 ± 2	-2 ± 2	$+4 \pm 2$	$+10 \pm 2$	$+23.5 \pm 2$

9. DISTORTION FACTOR

Minimize the GAIN control and set each of FADER and level controls in CH-INPUT (1) and MASTER at the NOMINAL POSITION in status 1. When a +14 dBs output is obtained at each output terminal of GROUP OUT (1 to 8), STEREO OUT (L, R), AUX OUT (1 to 8), AUX ST (1, 2), (L, R), MONITOR (A, B), (L, R) and TB OUT, the distortion factor should be less than 0.01 %.

When an output of 0 dBs is obtained at each terminal of PHONES (1, 2), (L, R), the distortion factor obtained at each terminal should be less than 0.7 %.

10. MAXIMUM OUTPUT

When a +24 dBs output is obtained at each output terminal of GROUP OUT (1 to 4), STEREO OUT (L, R), AUX OUT (1 to 8), AUX ST (1, 2), (L, R), MTRX OUT (1 to 8), MONI (A, B), (L, R) and TB OUT in status 1, confirm that the distortion factor should be less than 1 %.

Also, the distortion factor should be less than 1 % when +20 dBs is obtained at each output terminal of AUX OUT 3, 4.

When an output of +3 dBs is obtained at each terminal of the PHONES (1, 2), (L, R), the distortion factor obtained at each terminal should be less than 1 %.

11. VU Meter

When +4 dBs output is obtained at each output of GROUP OUT (1 to 8), STEREO OUT (L, R), AUX OUT (1 to 8), AUX ST (1, 2), (L, R), MONI A OUT (L, R), MATRIX OUT (1 to 8), TB OUT and OSC OUT in status 1, the indication on the VU meter should be within 0 ± 1 VU. When the meter selector switch is changed over to each output, the VU meter indication should be within 0 ± 1 VU.

If the indication is not within 0 ± 1 VU, adjust VR101 and VR102 on the pcb so that the indication is within the rated value.

Also, the built-in red PEAK LED should light up when the output is $+23.5 \pm 2$ dBs.

12. NOISE LEVEL

When the HOT, COLD of each input terminal of CH-INPUT and ST-INPUT is shorted with an 150 ohms in status 1, the noise level at GROUP OUT (1) should be less than -34 dBs.

* If the noise level is more than -34 dBs, find the noise level by input conversion. If this noise level is less than -128 dBs, then it is acceptable.

* When a signal is applied to stereo R input, measure at GROUP OUT (2).

13. RESIDUAL NOISE

Set the FADER and AUX level controls of all CH-INPUT and ST-INPUT at MIN in status 1 and turn the assign switch off and turn the ON switch of each output of MASTER on. In this state, when MASTER FADER and MASTER level controls have been set at maximum or minimum, the noise level should fall within the levels shown in Table 13.

Table 13 Residual Noise

Units: dBs

GROUP & STEREO FADER AUX & CUE VOLUME	GROUP OUT (1-8)	STEREO OUT (L, R)	AUX OUT (1-8)	AUX ST OUT (L, R)	MATRIX OUT (1-8)	MONI A OUT (L, R)
MAXIMUM	-75	-74	-71	-71	-94	-73 *1
MINIMUM	-100	-100	-100	-99	-100	-100

*1 Turn MATRIX CUE switch on.

14. PHASE

The signal phase applied to each input terminal and the signal phase obtained at each output terminal should be the same. And check that the applied signal to each input terminal and the signal obtained at each output terminal should be in negative phase when the PHASE SW of CH-INPUT or ST-INPUT is switched on.

* Pin polarity of balanced type input / output terminal
 (XLR type) (PHONE type)
 PIN 1: GND T: HOT (+)
 PIN 2: HOT (+) R: COLD (-)
 PIN 3: COLD (-) S: GND

PM4000/PW4000

15. OSCILLATOR

Turn on TB OUT, OSC OUT and "10kHz" switches in status 1, the output levels of TB OUT and OSC OUT are $+14 \pm 2$ dBs. Check for the same at "1kHz", "100Hz" and "PINK".

At this time, check that the distortion rates of "10kHz", "1kHz" and "100Hz" should be less than 1 %.

Check that the output levels and frequencies of TB OUT and OSC OUT are within the range given in Table 15, when the SWEEP switch and OSC FREQ control are changed.

Table 15

OSC SW	OSC FREQ volume				SWEEP SW. OFF
	MIN		MAX		
	LEVEL (dB)	FREQ. (Hz)	LEVEL (dB)	FREQ. (Hz)	
10kHz	$+14 \pm 2$	$2\text{kHz} \pm 20\%$	$+14 \pm 2$	$20\text{kHz} \pm 20\%$	$10\text{kHz} \pm 20\%$
1kHz	$+14 \pm 2$	$200\text{Hz} \pm 20\%$	$+14 \pm 2$	$2\text{kHz} \pm 20\%$	$1\text{kHz} \pm 20\%$
100Hz	$+14 \pm 2$	$20\text{Hz} \pm 20\%$	$+14 \pm 2$	$200\text{Hz} \pm 20\%$	$100\text{Hz} \pm 20\%$

The OSC ON LED indicator should lit until the OSC switch is turned off.

16. CUE

Check that the INPUT CUE and CUE LED indicators should light up when either one of the CUE switches of CH-INPUT and ST-INPUT is turned on. Also, if the CUE/SOLO OFF/CONNECT switch is turned to CONNECT and pin 22 of the EXT CONTROL connector is short-circuited to ground, INPUT CUE and CUE LED indicators should light up.

Check that INPUT CUE and CUE LED indicators go off when the CUE/SOLO OFF/CONNECT switch is turned to OFF. At this time, the signal from MASTER CUE switch is muted.

When either one of CUE switches in MASTER is turned on, only the CUE LED should be lit.

17. SOLO MODE

Check that the SOLO MODE and SOLO LED indicators flash when the SOLO MODE switch is turned on. When the ON switches of all CH-INPUTs and ST-INPUTs are turned on, and either one of the CUE switches of CH-INPUT or ST-INPUT is switched on, the ON LED with switch that has been turned on should remain lit, and the other ON LEDs should go off. At this stage, the signal from the module with the ON LED that has been turned off should be cut off.

Check that the same result can be obtained when the CUE/SOLO OFF/CONNECT switch is turned to CONNECT and pin 23 of the EXT CONTROL connector is shorted to ground.

When the SOLO SAFE switch in ST-INPUT is turned on, the ON LED should be on even if the another CUE switch is turned on.

When the SOLO SAFE switch is turned off, the ON LED should go off.

18. VCA CONTROL

When only one of the VCA GROUP switches (1 to 8) in each of CH-INPUT and ST-INPUT is turned on under condition in status 1, the output level of GROUP OUT (1) is $+10 \pm 2$ dB with the level when the switch is off as the reference.

Check that when all of VCA MASTER (1 to 8) faders are minimized and only one of the VCA GROUP switches (1 to 8) in each CH-INPUT and ST-INPUT is turned on, the output level of GROUP OUT (1) is less than -80 dB, with the level when the switch is off as the reference.

The NOMINAL LED should light up within the range of 0 ± 1 dB on the panel scale.

19. MUTE CONTROL

Turn on the ON switch in all CH-INPUTs and ST-INPUTs.

And, turn on a switch of MUTE MASTER (1 to 8) switches, and turn on the same number switch of MUTE (1 to 8) of CH-INPUT or ST-INPUT is turned on, check that the ON LED of that number module should go off.

At this time, the signal should be muted from the module whose ON LED has gone off.

When the MUTE SAFE switch is turned on under this condition, MUTE should be canceled.

20. EXTERNAL VCA CONTROL

When VCA CONTROL switches (1-4) and (5-8) are set at MASTER, and each of the VCA MASTER faders (1 to 8) is operated, the output within the range given in Table 20 should be obtained at each VAC BUS terminal of the EXTERNAL CONTROL connector.

Check that the output in the range of 0 ± 0.5 V can be obtained, regardless of the VCA MASTER fader when the VCA CONTROL switches are turned to SLAVE. And, when they are set to OFF, it is released.

Table 20

VCA MASTER FADER	VOLTAGE
MAX	$+0.5 \pm 0.05$ V
MIN	less than -9 V

21. EXTERNAL MUTE CONTROL

Turn each ON switch of CH-INPUT (1 to 8) on, and turn on the MUTE switch matching the appropriate channel number. And, set the MUTE CONTROL switches (1-4) and (5-8) to SLAVE.

When each of the MUTE buses (1 to 8) of the MUTE CONTROL connector is successively short-circuited to ground, that the corresponding grounded channel is muted.

When the MUTE CONTROL switches (1-4) and (5-8) are set to SLAVE, the INPUT module should not be muted even if the MUTE MASTER switch is turned on.

22. PHANTOM

Connect a load resistance (10 kohms, 1 W or greater) between the input connector pins 1 and 2 of each CH-INPUT, ST-INPUT and TB, and short pins 2 and 3.

When the PHANTOM MASTER has been switched on, and +48V switch of each module is turned on, a voltage of $+35 \pm 3$ V should be obtained at both ends of the load resistance.

23. LAMP POWER SUPPLY

When the load resistance (3 kohms, 5 W or greater) is connected between the XLR connector pins 3 and 4, and the LAMP DIMMER is operated, the voltage at both ends of the load resistance should be within the range given in the Table 23.

LAMP DIMMER	VOLTAGE
MAX	$+11 \pm 1$ V
MIN	$+2 \pm 1$ V

24. FAN SPEED SWITCH

When the FAN switch is switched to LOW/HIGH, the operating speed of the mounted cooling fans is set at LOW/HIGH.

25. POWER INDICATOR

Check that +12V, +20V, -20V and +48V LED indicators light up green in status 1, When the PHANTOM MASTER is turned on, the color of the +48V LED should change to red.

Check that when the POWER switch is turned on, the PW CAUTION LED lights up red just a second, and then goes right back off.

26. POWER SUPPLY VOLTAGE FLUCTUATION

Even a fluctuation of $\pm 10\%$ in the rated power supply voltage should pose no problems in the operations.

27. MEASURING EQUIPMENT

- * The balanced output type oscillator is to be used.
- * The output impedance of the oscillator should be less than 10 ohms.
- * The input impedance of the oscilloscope and the level meter should be more than 100 kohms.
- * Noise level should be measured using a 12.7 kHz, -6 dB/oct. low-pass filter.
- * We recommend that balanced input type measuring instruments are to be used.

■ PM4000 ADJUSTMENTS

1. MONAURAL INPUT MODULE AND STEREO INPUT MODULE

1-1. PREPARATIONS

- 1) Connect the PM4000 and a PW4000 via the supplied DC power supply cable.
- 2) The signal level referred to in this specifications is 0 dBs = 0.775 V.
- 3) Unless specified, controls and switches must be set as follows:
 - ASSIGN switch OFF
 - PAN switch OFF
 - + 48V switch OFF
 - PAN control CENTER
 - INPUT SELECTER switch ST (STEREO INPUT only)
 - GAIN trim MIN
 - PAD (30dB) switch OFF
 - φ switch OFF (positive phase)
 - EQ (HI, HI-MID, LO-MID, LO)
 - LEVEL control CENTER
 - FREQ control MIN
 - Q control CENTER
 - ON switch OFF
 - (HI, LO)
 - SHELF switch OFF (PEAK)
 - HPF FREQ control MIN
 - HPF switch OFF
 - INSERT ON switch OFF
 - INSERT PRE switch OFF (POST)
 - AUX 1-8
 - LEVEL control MAX
 - PRE/OFF/POST switch OFF
 - AUX ST 1, 2
 - LEVEL (LEVEL L) control MAX
 - PAN (LEVEL R) control CENTER
 - PRE/OFF/POST switch OFF
 - LEVEL/PAN switch PAN
 - METER PRE switch ON
 - ON switch ON
 - VCA GROUP (1-8) switch OFF
 - MUTE GROUP (1-8) switch OFF
 - MUTE SAFE switch OFF
 - CUE/SOLO switch ON
 - Fader MAX
 - Internal switch Set at the "▼" mark

1-2. STEP 1: VCA STANDARD VOLTAGE ADJUSTMENT

Adjust the trimmer potentiometer so that the voltage is $-0.5 \pm 0.01V$ at test point T102, under the conditions given in 1-1.

Table 1-2

MODULE	Measure at	Voltage	Trimmer potentiometer for adjustment
MONAURAL INPUT	TP102	$-0.5 \pm 0.01V$	VR126 of IN3 board
STEREO INPUT	TP102	$-0.5 \pm 0.01V$	VR125 of SI3 board

1-3. STEP 2: VCA OFFSET ADJUSTMENT

Set the fader to "∞", apply no signal, and adjust the trimmer potentiometer so that the voltage at each test point falls within the range shown in Table 1-3.

Table 1-3

MODULE	Measure at	Voltage	Trimmer potentiometer for adjustment
MONAURAL INPUT	TP101	0 ± 5 mV	VR132 of IN1 board
STEREO INPUT	TP101	0 ± 5 mV	VR132 of S11 board
	TP201	0 ± 5 mV	VR332 of S11 board

1-4. STEP 3: VCA OFFSET A ADJUSTMENT (When GAIN is 0 dB.)

Set the fader to "0", apply no signal, and adjust the trimmer potentiometer so that the voltage at each test point falls within the range shown in Table 1-4.

Table 1-4

MODULE	Measure at	Voltage	Trimmer potentiometer for adjustment
MONAURAL INPUT	TP101	0 ± 10 mV	VR128 of IN1 board
STEREO INPUT	TP101	0 ± 10 mV	VR128 of S11 board
	TP201	0 ± 10 mV	VR328 of S11 board

1-5. STEP 4: VCA OFFSET B ADJUSTMENT (When GAIN is +20 dB.)

Set the fader to "10", apply 0.5 ± 10 mV DC to VCA CONTROL 1 terminal from an external device, and turn on the VCA GROUP ASSIGN 1 switch. Adjust the trimmer potentiometer so that the voltage at each test point falls within the range shown in Table 1-5.

Table 1-5

MODULE	Measure at	Voltage	Trimmer potentiometer for adjustment
MONAURAL INPUT	TP101	0 ± 10 mV	VR131 of IN1 board
STEREO INPUT	TP101	0 ± 10 mV	VR131 of S11 board
	TP201	0 ± 10 mV	VR331 of S11 board

Repeat the adjustment to both OFFSET A and OFFSET B until both adjusted values are satisfied. A 0.5 ± 10 mV can be applied via the VCA control bus of the MASTER module which the inspection and adjustment has been performed.

1-6. STEP 5: DISTORTION ADJUSTMENT (When GAIN is 0 dB.)

Set the GAIN control to MIN, turn on the channel ON switch, set PAN to OFF, and turn "1" or "2" of ASSIGN switch on.

Adjust the input signal level so that the output signal level is +20 dB at the output terminal as shown in Table 1-6. Set the fader to "0", and adjust the trimmer potentiometer so that the distortion rate obtained at each output is the value shown in Table 1-6.

Table 1-6

MODULE	Measure at	Distortion rate	Trimmer potentiometer for adjustment
MONAURAL INPUT	TP103	The best value	VR129 of IN1 board
STEREO INPUT	TP103	The best value	VR129 of S11 board
	TP203	The best value	VR329 of S11 board

1-7. STEP 6: DISTORTION ADJUSTMENT (When GAIN is + 20 dB.)

Under the conditions given in 1-6, adjust the input signal level so that the output signal level is + 20 dB at the output terminal as shown in Table 1-7.

Set the fader to "10", apply 0.5 ± 10 mV DC to VCA CONTROL 1 terminal from an external device, and turn on the VCA GROUP ASSIGN 1 switch. Adjust the trimmer potentiometer so that the distortion rate obtained at each output is the value shown in Table 1-7.

Table 1-7

MODULE	Measure at	Distortion rate	Trimmer potentiometer for adjustment
MONAURAL INPUT	TP103	The best value	VR130 of IN1 board
STEREO INPUT	TP103	The best value	VR130 of SI1 board
	TP203	The best value	VR330 of SI1 board

Repeat the adjustment so that the distortion rate is 0.01% or less when GAIN is 0 dB and also when GAIN is +20B.

A 0.5 ± 10 mV can be applied via the VCA control bus of the MASTER module which the inspection and adjustment has been performed.

1-8. STEP 7: VCA MUTING

Set the GAIN control to MIN, and set the input signal level to 0 dBs and set the fader to " ∞ (infinite)". Adjust the trimmer potentiometer so that the waveform amplitude of the output signal obtained at the output terminal shown in Table 1-8 is the minimum, at this point.

Table 1-8

MODULE	Measure at	Trimmer potentiometer for adjustment
MONAURAL INPUT	TP103	VR132 of IN1 board
STEREO INPUT	TP103	VR132 of SI1 board
	TP203	VR332 of SI1 board

1-9. LED (METER, PEAK) LIGHTING LEVEL

Turn on the MTR PRE switch to apply the signal, under the conditions given in 1-1, and adjust the trimmer potentiometer so that the LED "O" lights up when the output level of INSERT OUT is + 4 dBs. Check that LED "O" goes off when the input signal level is decreased by 1 dB.

Table 1-9

MODULE	Output terminal	Trimmer potentiometer for adjustment
MONAURAL INPUT	INSERT OUT	VR125 of IN3 board
STEREO INPUT	INSERT OUT L	VR126 of SI3 board
	INSERT OUT R	VR127 of SI3 board

(Load resistance of the INSERT OUT terminal should be 10 kohms or higher.)

2. TALKBACK MODULE

2-1. PREPARATIONS

- 1) Connect the PM4000 and a PW4000 via the supplied DC power supply cable.
- 2) The signal level referred to in this specifications is 0 dBs = 0.775 V.
- 3) Unless specified, controls and switches must be set as follows:

ASSIGN switch	ON during measurement only, OFF at all other times.
TB OUT switch	ON
OSC OUT switch	ON
OSC switch	OFF
OSC FREQ control	MIN
SWEEP switch	OFF
OSC LEVEL control	MAX
+48V switch	OFF
+4dB switch	OFF (-50 dB)
TB LEVEL control	MAX
ON/OFF/ON switch	ON during measurement only, OFF at all other times.
METER SELECT switch	1 : G 2 : A
MUTE MASTER switch (1-8)	OFF

2-2. Oscillator

Adjust the trimmer potentiometer so that the distortion rate of GROUP 1 terminal output signal is 1% or less (which is the minimum) when the TB ASSIGN switch (GROUP 1) and "1kHz" switch are turned on under the conditions given in 2-1. Then, adjust the trimmer potentiometer VR204 so that the output level is 10 ± 0.5 dBs.

Adjust the trimmer potentiometer VR201 so that the output signal level is 10 ± 0.5 dBs when the "PINK" switch is turned on, under the conditions given.

3. MASTER MODULE

3-1. PREPARATIONS

- 1) Connect the PM4000 and a PW4000 via the supplied DC power supply cable.
- 2) The signal level referred to in this specifications is 0 dBs = 0.775 V.
- 3) Unless specified, controls and switches must be set as follows:

GROUP (1-8)	
PAN control	CENTER
GROUP TO ST switch	ON during measurement only, OFF at all other times.
GROUP TO MATRIX switch	ON during measurement only, OFF at all other times.
INSERT switch	ON during measurement only, OFF at all other times.
CUE switch	ON during measurement only, OFF at all other times.
ON switch	ON during measurement only, OFF at all other times.
Fader	MAX
MATRIX	
SUB IN control	MAX during measurement only, MIN at all other times.
MATRIX MIX control	MAX during measurement only, MIN at all other times.
MASTER control	MAX
INSERT switch	ON during measurement only, OFF at all other times.
ON switch	ON during measurement only, OFF at all other times.
AUX	
LEVEL control	MAX
INSERT switch	ON during measurement only, OFF at all other times.
ON switch	ON during measurement only, OFF at all other times.
Internal switch	Set at the "▼" mark.