

POWER SUPPLY

PW800W

SERVICE MANUAL



■ CONTENTS (目次)

SPECIFICATIONS (総合仕様).....	3
PANEL LAYOUT (パネルレイアウト).....	4
DIMENSIONS (寸法図).....	5
CIRCUIT BOARD LAYOUT (ユニットレイアウト).....	6
DISASSEMBLY PROCEDURE (分解手順).....	7
CIRCUIT BOARDS (シート基板図).....	10
PARTS LIST	
OVERALL CONNECTOR CIRCUIT DIAGRAM (総コネクタ接続回路図)	
OVERALL CIRCUIT DIAGRAM (総回路図)	

IMPORTANT NOTICE

This manual has been provided for the use of authorized Yamaha Retailers and their service personnel. It has been assumed that basic service procedures inherent to the industry, and more specifically Yamaha Products, are already known and understood by the users, and have therefore not been restated.

WARNING : Failure to follow appropriate service and safety procedures when servicing this product may result in personal injury, destruction of expensive components and failure of the product to perform as specified. For these reasons, we advise all Yamaha product owners that all service required should be performed by an authorized Yamaha Retailer or the appointed service representative.

IMPORTANT : This presentation or sale of this manual to any individual or firm does not constitute authorization certification, recognition of any applicable technical capabilities, or establish a principal-agent relationship of any form.

The data provided is believed to be accurate and applicable to the unit(s) indicated on the cover. The research engineering, and service departments of Yamaha are continually striving to improve Yamaha products. Modifications are, therefore, inevitable and changes in specification are subject to change without notice or obligation to retrofit. Should any discrepancy appear to exist, please contact the distributor's Service Division.

WARNING : Static discharges can destroy expensive components. Discharge any static electricity your body may have accumulated by grounding yourself to the ground bus in the unit (heavy gauge black wires connect to this bus.)

IMPORTANT : Turn the unit OFF during disassembly and parts replacement. Recheck all work before you apply power to the unit.

WARNING: CHEMICAL CONTENT NOTICE!

The solder used in the production of this product contains LEAD. In addition, other electrical/electronic and/or plastic (Where applicable) components may also contain traces of chemicals found by the California Health and Welfare Agency (and possibly other entities) to cause cancer and/or birth defects or other reproductive harm.

DO NOT PLACE SOLDER, ELECTRICAL/ELECTRONIC OR PLASTIC COMPONENTS IN YOUR MOUTH FOR ANY REASON WHATSOEVER SO EVER!

Avoid prolonged, unprotected contact between solder and your skin! When soldering, do not inhale solder fumes or expose eyes to solder/flux vapor!

If you come in contact with solder or components located inside the enclosure of this product, wash your hands before handling food.

IMPORTANT NOTICE FOR THE UNITED KINGDOM

Connecting the Plug and Cord

WARNING: THIS APPARATUS MUST BE EARTHED
IMPORTANT. The wires in this mains lead are coloured in accordance with the following code:

GREEN-AND-YELLOW	: EARTH
BLUE	: NEUTRAL
BROWN	: LIVE

As the colours of the wires in the mains lead of this apparatus may not correspond with the coloured markings identifying the terminals in your plug proceed as follows:

The wire which is coloured GREEN-and-YELLOW must be connected to the terminal in the plug which is marked by the letter E or by the safety earth symbol  or colored GREEN or GREEN-and-YELLOW.

The wire which is coloured BLUE must be connected to the terminal which is marked with the letter N or coloured BLACK.

The wire which is coloured BROWN must be connected to the terminal which is marked with the letter L or coloured RED.

•This applies only to products distributed by Yamaha-Kemble Music (U.K.) Ltd.(3 wires)

■ WARNING

Components having special characteristics are marked  and must be replaced with parts having specification equal to those originally installed.



印の商品は、安全を維持するために重要な部品です。交換する場合は、安全のために必ず指定の部品をご使用ください。

■ SPECIFICATIONS(総合仕様)

General Specifications

Power Consumption	1000W	
Dimensions (W x H x D)	480 mm x 142 mm x 384 mm	
Weight	10 kg	
Included Accessories	Power cord, Cord clamp, Owner's Manual	
Temperature Range	Operating	10°C – 35°C
	Storage	-20°C – 60°C

一般仕様

消費電力	1000W	
外形寸法 (W x H x D)	480mm x 142mm x 384mm	
質量	10kg	
付属品	電源コード、誤脱防止クランプ、取扱説明書、保証書	
温度範囲	使用時	10 ~ 35
	保管時	-20 ~ 60

Power Connector Pin Diagram (電源コネクタの形状)

DC PARALLEL INPUT

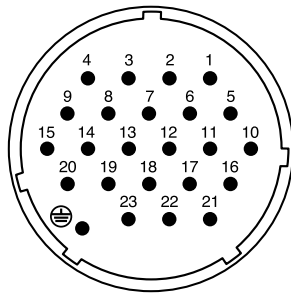

DC OUTPUT

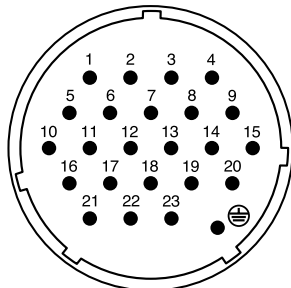

Power Supply Cable Pin Assignments (電源ケーブルのピン配列)

No.	Function	No.	Function
1	+24V	13	GND
2	+24V	14	GND
3	+24V	15	GND
4	+24V	16	GND
5	+24V	17	GND
6	+24V	18	GND
7	+24V	19	CAUTION (+)
8	+24V	20	CAUTION (-)
9	+24V	21	DETECT A
10	GND	22	DETECT B
11	GND	23	DETECT GND
12	GND	⊖	Frame GND

■ PANEL LAYOUT (パネルレイアウト)

● Front Panel(フロントパネル)



❶ POWER ON/OFF Switch ([POWER ON/OFF] スイッチ)

● Rear Panel(リアパネル)

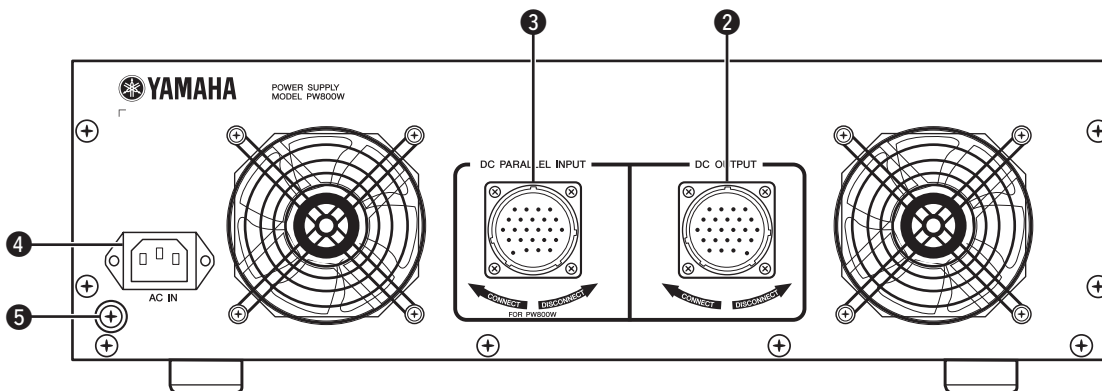

- ❷ DC OUTPUT Connector (DC OUTPUT コネクター)
- ❸ DC PARALLEL INPUT Connector (DC PARALLEL INPUT コネクター)
- ❹ AC IN Connector (AC IN 端子)
- ❺ GROUND Screw Terminal (アース用ネジ)

■ DIMENSIONS(寸法図)

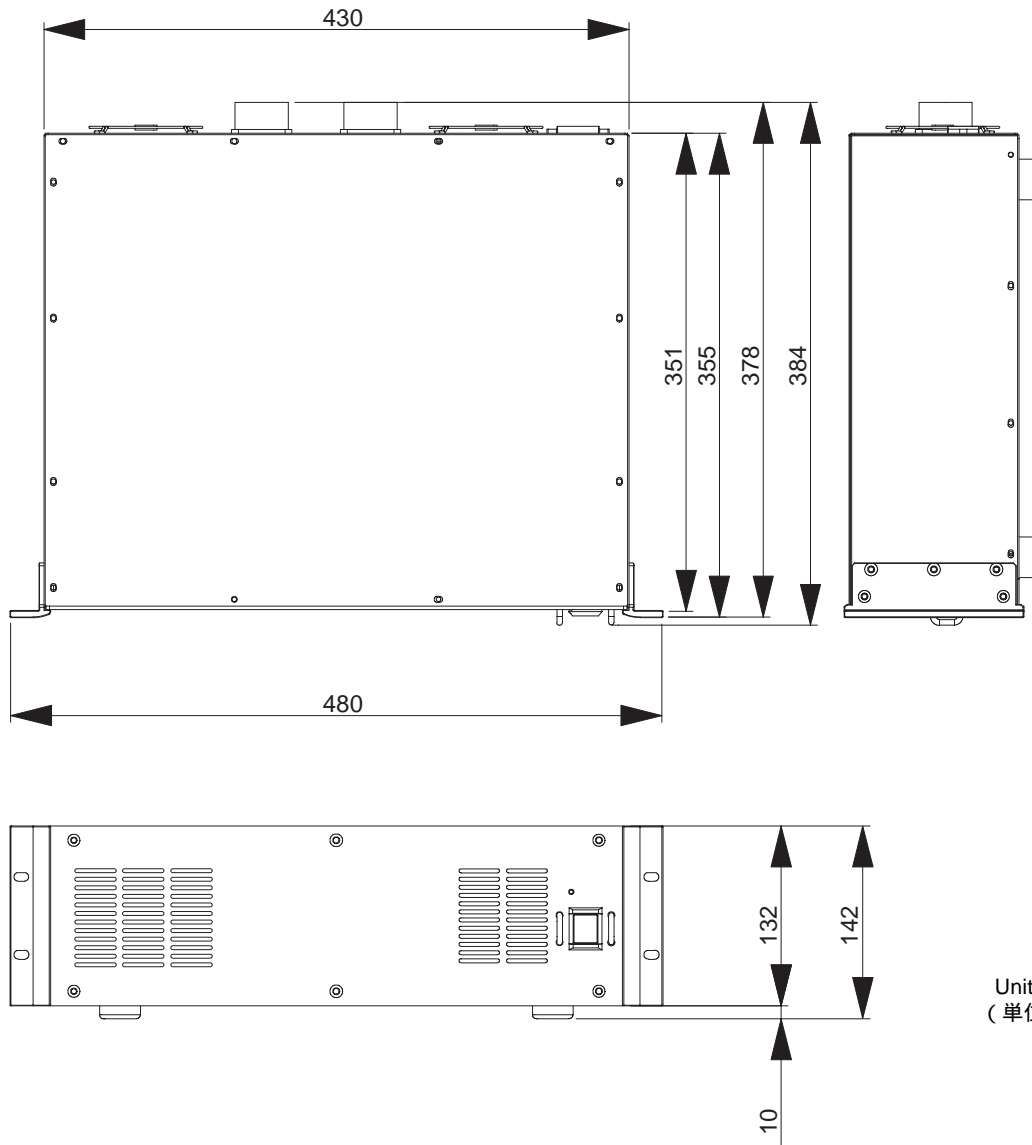

Units: mm
(单位)

■ CIRCUIT BOARD LAYOUT(ユニットレイアウト)

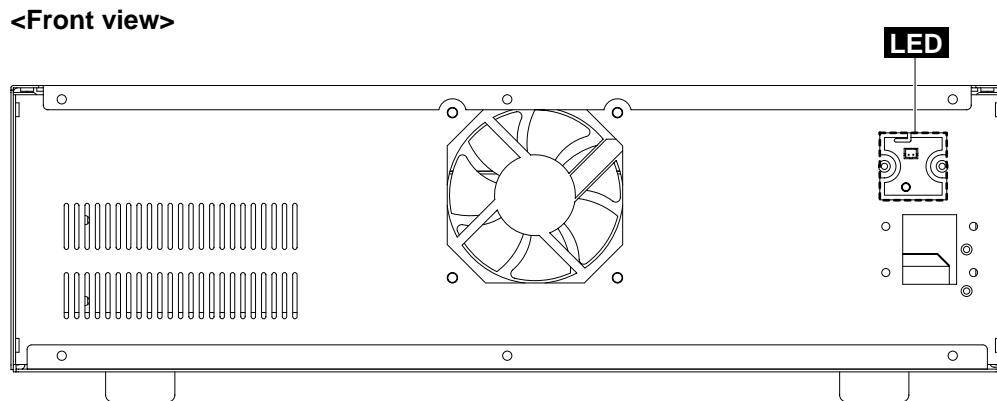
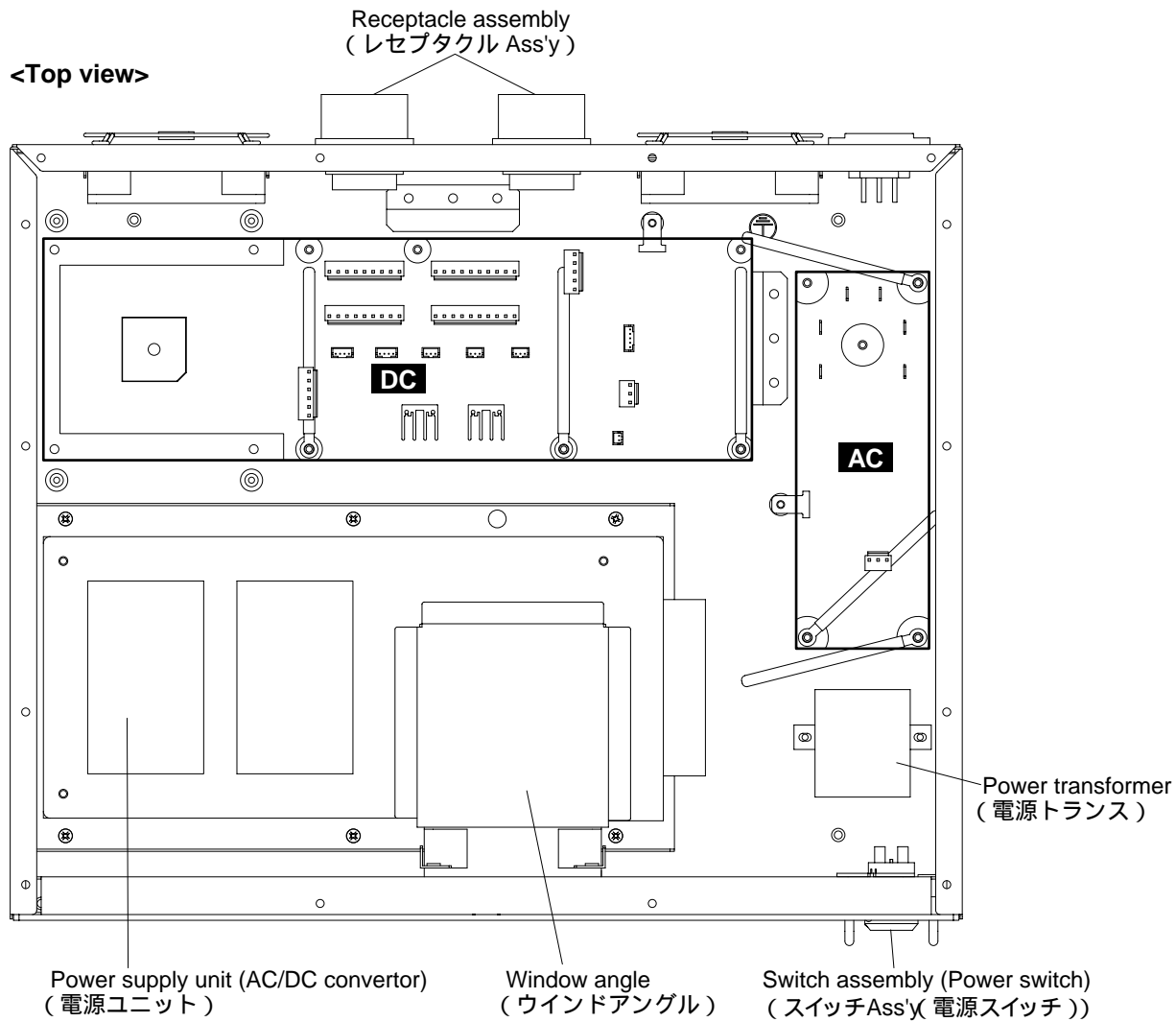

■ DISASSEMBLY PROCEDURE(分解手順)

1. **Top Cover**
(Time required : About 1 minute)
Remove the fourteen (14) screws marked [390]. The top cover can then be removed. (Fig. 1)
 2. **Power Supply Unit**
(Time required : About 2 minutes)
 - 2-1. Remove the top cover. (See procedure 1)
 - 2-2. Remove the six (6) screws marked [240]. The power supply unit and the window angle can then be removed. (Fig. 1)
 - 2-3. Remove the three (3) screws marked [225] and the screw marked [230A]. The window angle can then be removed from the power supply unit. (Fig. 1)
 - 2-4. Remove the four (4) screws marked [230B]. The SW power angle can then be removed from the power supply unit. (Fig. 1)
 3. **DC Circuit Board**
(Time required : About 2 minutes)
 - 3-1. Remove the top cover. (See procedure 1)
 - 3-2. Remove the eleven (11) screws marked [310]. The DC circuit board can then be removed. (Fig. 1)
 - 3-3. Remove the four (4) screws marked [290] and the screw marked [300]. The heat sink and holder can then be removed from the DC circuit board. (Fig. 1)
 4. **AC Circuit Board**
(Time required : About 1 minute)
 - 4-1. Remove the top cover. (See procedure 1)
 - 4-2. Remove the six (6) screws marked [200]. The AC circuit board can then be removed. (Fig. 1)
 5. **LED Circuit Board**
(Time required : About 1 minute)
 - 5-1. Remove the top cover. (See procedure 1)
 - 5-2. Remove the two (2) screws marked [180]. The LED circuit board can then be removed. (Fig. 1)
 6. **Power Transformer**
(Time required : About 1 minute)
 - 6-1. Remove the top cover. (See procedure 1)
 - 6-2. Remove the two (2) screws marked [317]. The power transformer can then be removed. (Fig. 1)
 7. **Switch Assembly (Power Switch)**
(Time required : About 4 minutes)
 - 7-1. Remove the top cover. (See procedure 1)
 - 7-2. Remove the connector pins connected to K6 to K9 terminals of the AC circuit board.
 - 7-3. Remove the six (6) screws marked [330] and the four (4) screws marked [355]. The front panel can then be removed. (Fig. 1)
 - 7-4. Remove the switch assembly (power switch) by bending its claw. (Fig. 1)
 8. **Front Fan Motor**
(Time required : About 3 minutes)
 - 8-1. Remove the top cover. (See procedure 1)
 - 8-2. Remove the six (6) screws marked [330] and the four (4) screws marked [355]. The front panel can then be removed. (Fig. 1)
 - 8-3. Remove the power switch. (See procedure 7)
 - 8-4. Remove the four (4) screws marked [120A]. The fan motor (front) and the two (2) fan guides can then be removed. (Fig. 1)
1. **トップカバー (所要時間:約1分)**
[390]のネジ14本を外し、トップカバーを外します。(図1)
 2. **電源ユニット (所要時間:約2分)**
 - 2-1. トップカバーを外します。(1項参照)
 - 2-2. [240]のネジ6本を外し、電源ユニットとウインドアングルを外します。(図1)
 - 2-3. [225]のネジ3本と[230A]のネジ1本を外し、電源ユニットからウインドアングルを外します。(図1)
 - 2-4. [230B]のネジ4本を外し、電源ユニットからSW電源取付け金具を外します。(図1)
 3. **DCシート (所要時間:約2分)**
 - 3-1. トップカバーを外します。(1項参照)
 - 3-2. [310]のネジ11本を外し、DCシートを外します。(図1)
 - 3-3. [290]のネジ4本と[300]のネジ1本を外し、DCシートからヒートシンクDS/ヒートシンク取付け金具を外します。(図1)
 4. **ACシート (所要時間:約1分)**
 - 4-1. トップカバーを外します。(1項参照)
 - 4-2. [200]のネジ6本を外し、ACシートを外します。(図1)
 5. **LEDシート (所要時間:約1分)**
 - 5-1. トップカバーを外します。(1項参照)
 - 5-2. [180]のネジ2本を外し、LEDシートを外します。(図1)
 6. **電源トランス (所要時間:約1分)**
 - 6-1. トップカバーを外します。(1項参照)
 - 6-2. [317]のネジ2本を外し、電源トランスを外します。(図1)
 7. **スイッチAss Y (電源スイッチ)**
(所要時間:約4分)
 - 7-1. トップカバーを外します。(1項参照)
 - 7-2. ACシートのK6～K9端子の圧着端子を外します。[330]のネジ6本と[355]のネジ4本を外し、フロントパネルを外します。(図1)
 - 7-4. 電源スイッチのツメを曲げて、スイッチAss Y (電源スイッチ)を外します。(図1)
 8. **フロントDCファンモーター (所要時間:約3分)**
 - 8-1. トップカバーを外します。(1項参照)
 - 8-2. [330]のネジ6本と[355]のネジ4本を外し、フロントパネルを外します。(図1)
 - 8-3. 電源スイッチを外します。(7項参照)
 - 8-4. [120A]のネジ4本を外し、DCファンモーター(front)とファンガイド2個を外します。(図1)

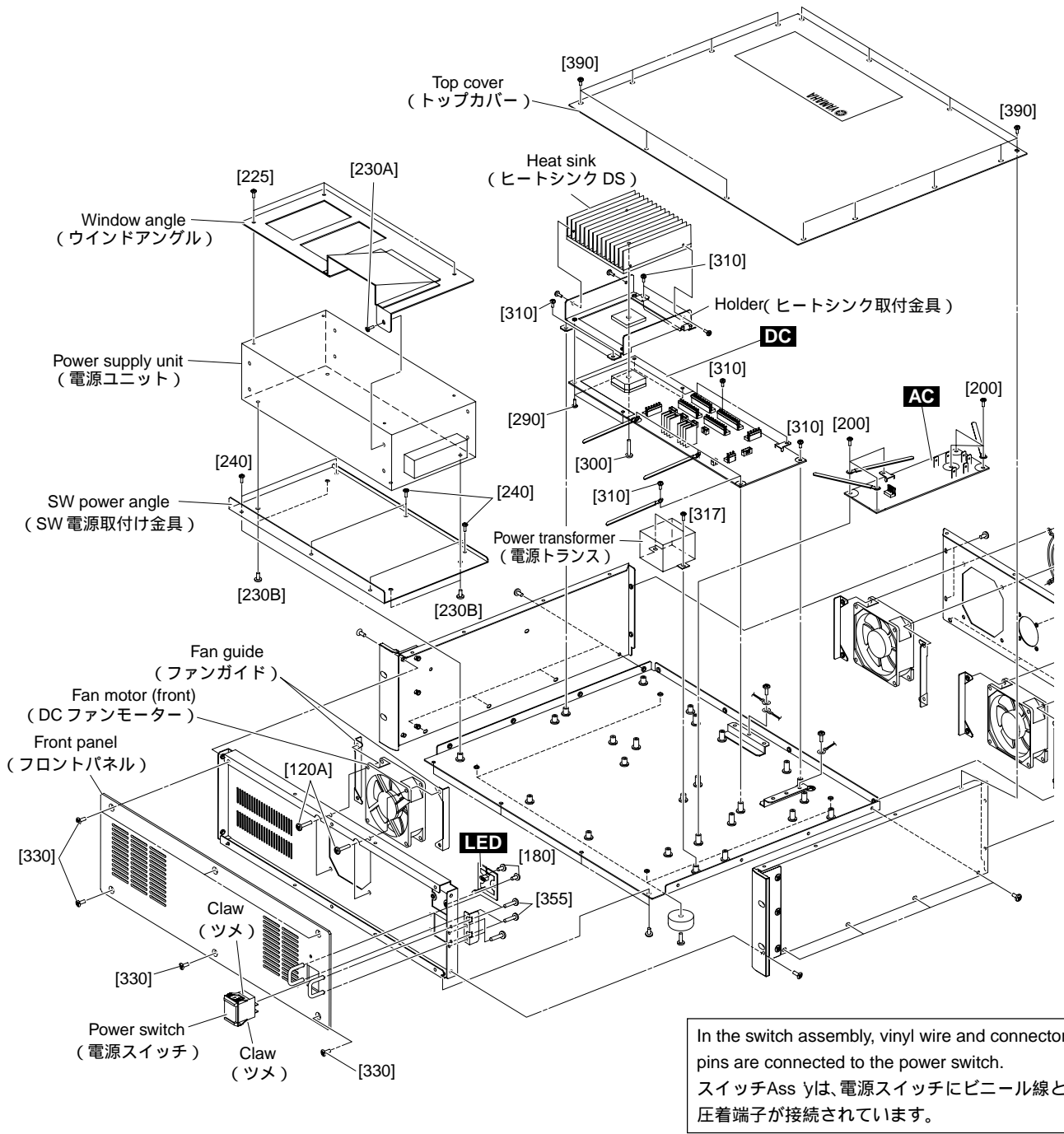

- | | |
|---|------------------------------|
| [120]: Pan Head Screw (+ ナベ小ネジ) | SP 4.0x20 MFZN2BL (VB671600) |
| [180]: Bind Head Tapping Screw-B (+ バインドBタイト) | 3.0x6 MFZN2BL (EP600230) |
| [200]: Bind Head Tapping Screw-B (+ バインドBタイト) | 3.0x6 MFZN2BL (EP600230) |
| [225]: Bind Head Screw (+ バインド小ネジ) | 3.0x8 MFZN2BL (VB659000) |
| [230]: Bind Head Screw (+ バインド小ネジ) | 4.0x8 MFZN2BL (EG340360) |
| [240]: Bind Head Tapping Screw-B (+ バインドBタイト) | 3.0x6 MFZN2BL (EP600230) |
| [290]: Bind Head Tapping Screw-B (+ バインドBタイト) | 3.0x6 MFZN2BL (EP600230) |
| [300]: Pan Head Screw (+ ナベ小ネジ) | SP 4.0x20 MFZN2BL (VB671600) |
| [310]: Bind Head Tapping Screw-B (+ バインドBタイト) | 3.0x6 MFZN2BL (EP600230) |
| [317]: Bind Head Tapping Screw-B (+ バインドBタイト) | 3.0x6 MFZN2BL (EP600230) |
| [330]: Oval Head Screw (+ 丸皿小ネジ) | 4.0x8 MFZN2BL (VS153600) |
| [355]: Pan Head Screw (+ ナベ小ネジ) | 2.6x4 MFZN2BL (EE620120) |
| [390]: Bind Head Tapping Screw-B (+ バインドBタイト) | 4.0x8 MFZN2BL (EG340190) |

Fig. 1 (図1)

9. Rear Fan Motor

(Time required : About 2 minutes)

- 9-1. Remove the top cover. (See procedure 1)
- 9-2. Remove the four (4) screws marked [120B]. The fan motor (L), the two (2) fan guides and the fan guard can then be removed. (Fig. 2)
- 9-3. Remove the four (4) screws marked [120C]. The fan motor (R), the two (2) fan guides and the fan guard can then be removed. (Fig. 2)

10. Receptacle Assembly

(Time required : About 2 minutes)

- 10-1. Remove the top cover. (See procedure 1)
- 10-2. Remove the screw marked [480A]. The ground wire can then be removed. (Fig. 2)
- 10-3. Remove the four (4) screws marked [140A]. The receptacle assembly (DC OUTPUT) can then be removed. (Fig. 2)
- 10-4. Remove the four (4) screws marked [140B]. The receptacle assembly (DC PARALLEL INPUT) can then be removed. (Fig. 2)

11. AC Inlet Assembly

(Time required : About 2 minutes)

- 11-1. Remove the top cover. (See procedure 1)
- 11-2. Remove the screw marked [480B]. The ground wire can then be removed. (Fig. 2)
- 11-3. Remove the two (2) supports marked [160]. The AC inlet assembly can then be removed. (Fig. 2)

9. リアDCファンモーター (所要時間:約2分)

- 9-1. トップカバーを外します。(1項参照)
- 9-2. [120B]のネジ4本を外し、DCファンモーター(L)、ファンガイド2個、ファンガードを外します。(図2)
- 9-3. [120C]のネジ4本を外し、DCファンモーター(R)、ファンガイド2個、ファンガードを外します。(図2)

10. レセプタクルAss'y (所要時間:約2分)

- 10-1. トップカバーを外します。(1項参照)
- 10-2. [480A]のネジ1本を外し、アース線を外します。(図2)
- 10-3. [140A]のネジ4本を外し、レセプタクルAss'y (DC OUTPUT)を外します。(図2)
- 10-4. [140B]のネジ4本を外し、レセプタクルAss'y (DC PARALLEL INPUT)を外します。(図2)

11. インレットAss'y (所要時間:約2分)

- 11-1. トップカバーを外します。(1項参照)
- 11-2. [480B]のネジ1本を外し、アース線を外します。(図2)
- 11-3. [160]のサポート2個を外し、インレットAss'yを外します。(図2)

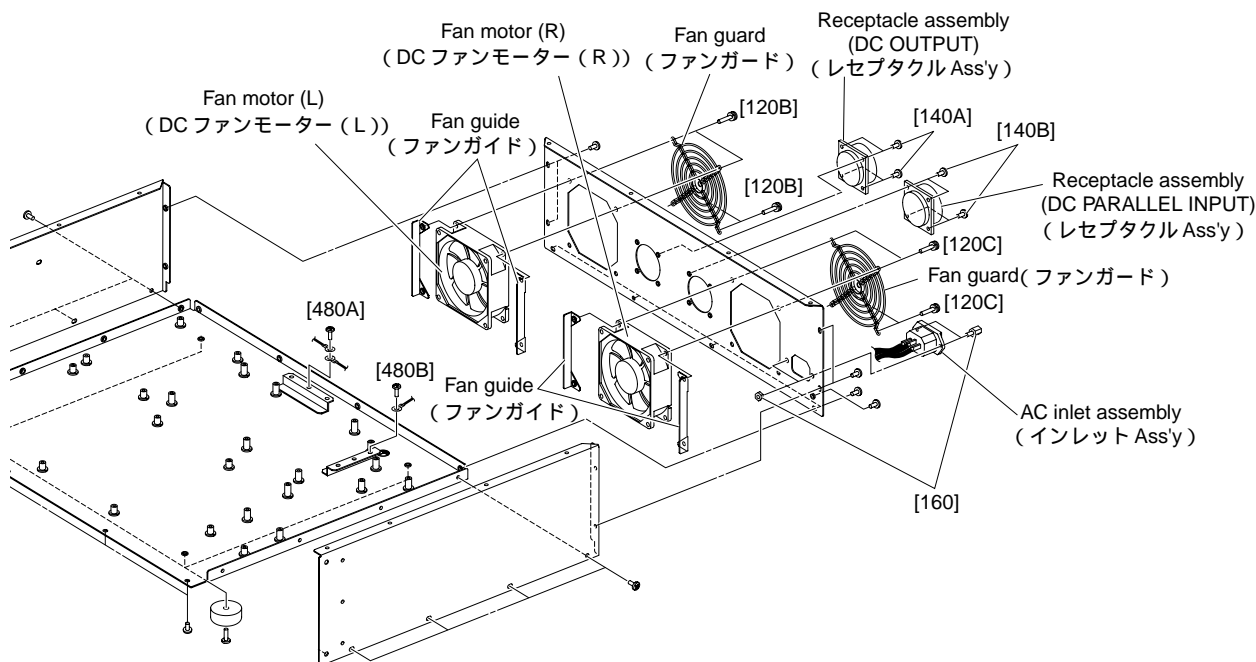

[120]:	Pan Head Screw	(+ナベ小ネジ)	SP	4.0x20 MFZN2BL	(VB671600)
[140]:	Bind Head Tapping Screw-B	(+パインドBタイト)		3.0x8 MFZN2BL	(EP600190)
[160]:	Support	(サポート)			(V5600300)
[480]:	Bind Head Screw	(+パインド小ネジ)		4.0x8 MFZN2BL	(EG340360)

Fig. 2 (図2)

■ CIRCUIT BOARDS(シート基板図)

● DC Circuit Board

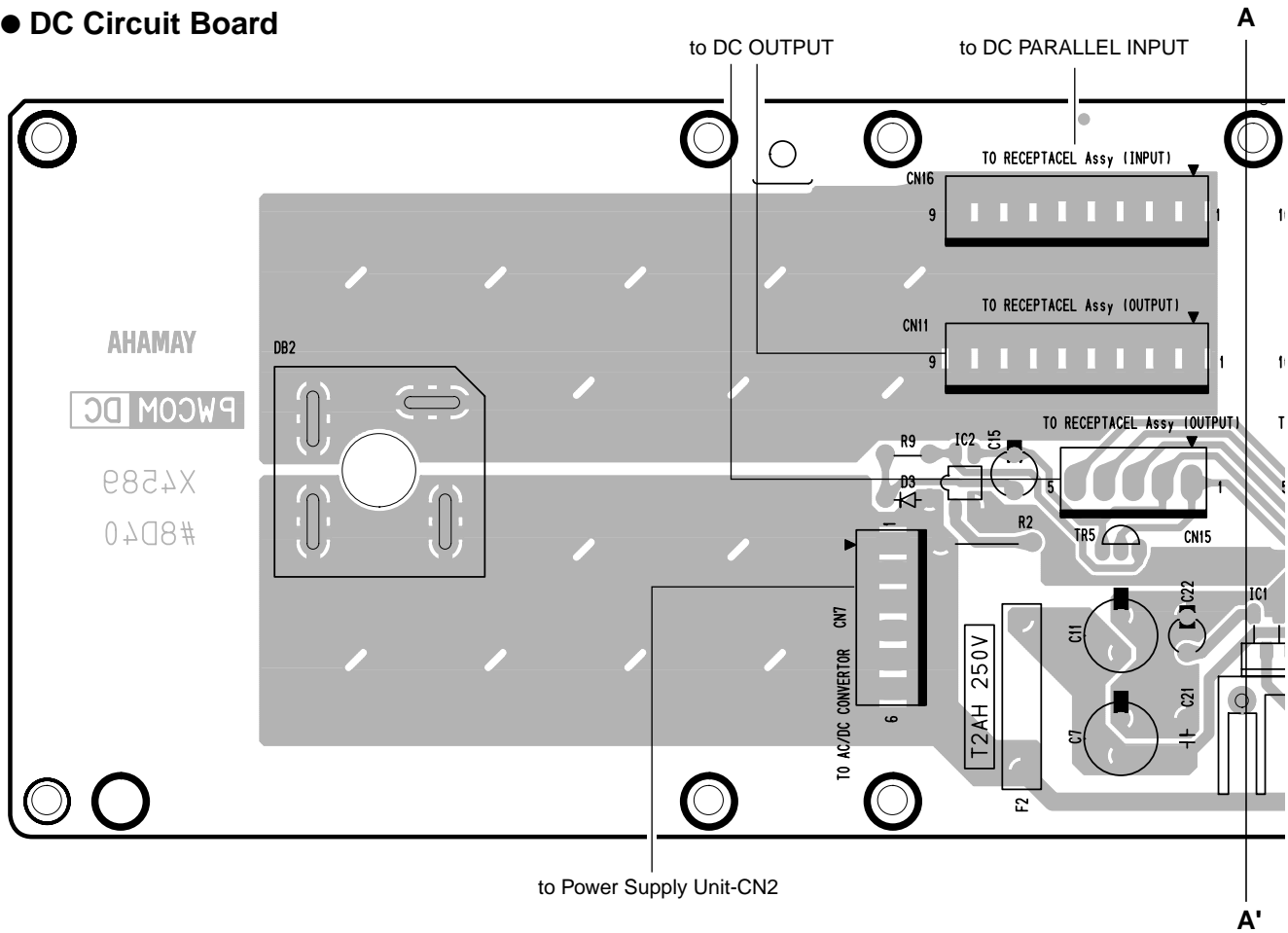

● AC Circuit Board

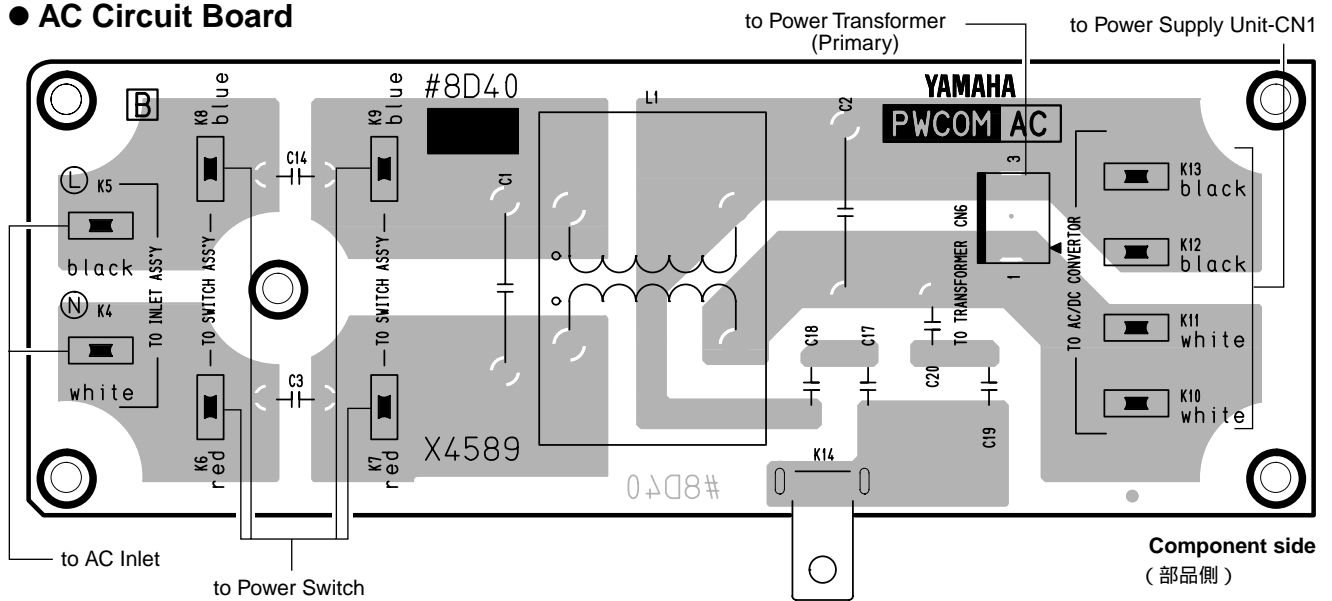

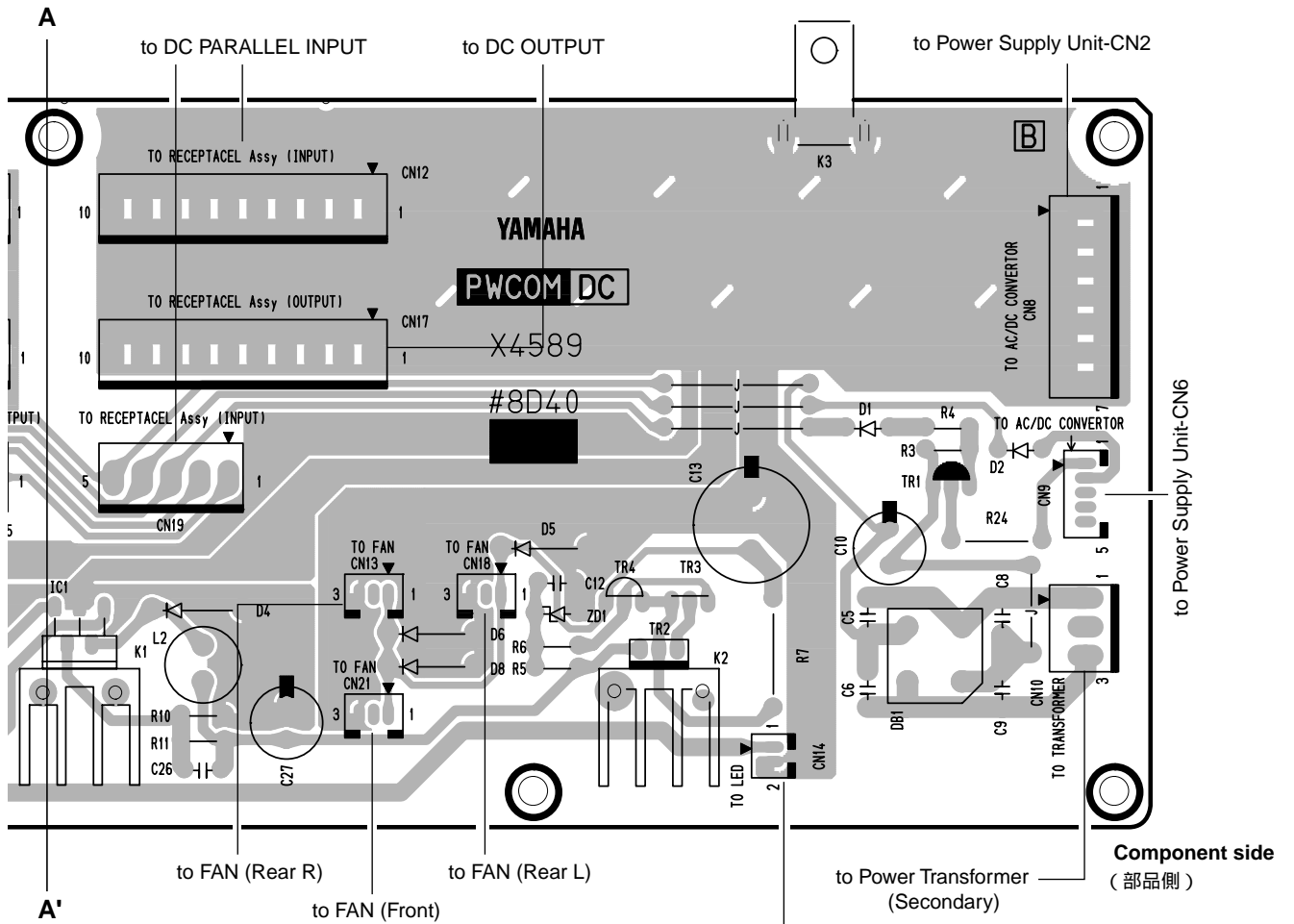

● LED Circuit Board

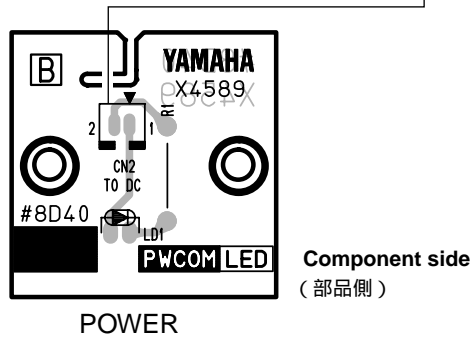

POWER SUPPLY

PW800W

PARTS LIST

■ CONTENTS (目次)

OVERALL ASSEMBLY (総組立)	2
ELECTRICAL PARTS (電気部品)	5~6

Notes : DESTINATION ABBREVIATIONS

A : Australian model	M : South African model
B : British model	O : Chinese model
C : Canadian model	Q : South-east Asia model
D : German model	T : Taiwan model
E : European model	U : U.S.A. model
F : French model	V : General export model (110V)
H : North European model	W : General export model (220V)
I : Indonesian model	N,X : General export model
J : Japanese model	Y : Export model
K : Korean model	

■ WARNING

Components having special characteristics are marked  and must be replaced with parts having specification equal to those originally installed.

 印の部品は、安全を維持するために重要な部品です。交換する場合は、安全のために必ず指定の部品をご使用ください。

- The numbers "QTY" show quantities for each unit.
- The parts with "--" in "PART NO." are not available as spare parts.
- This mark "}" in the REMARKS column means these parts are interchangeable.
- The second letter of the shaded (■) part number is O, not zero.
- The second letter of the shaded (■) part number is I, not one.
- 部品価格ランクは、変更になることがあります。
- QTY欄に記されている数字は、各ユニット当たりの使用個数です。
- PART NO.が"--"の部品は、サービス用部品として準備されておりません。
- REMARKS欄の「}」マークの部品は、併用部品です。
- 網掛けの付いたPART NO. の2番目の文字は「ゼロ」ではなく、「オー」です。
- 網掛けの付いたPART NO. の2番目の文字は「イチ」ではなく、「アイ」です。

OVERALL ASSEMBLY (總組立)

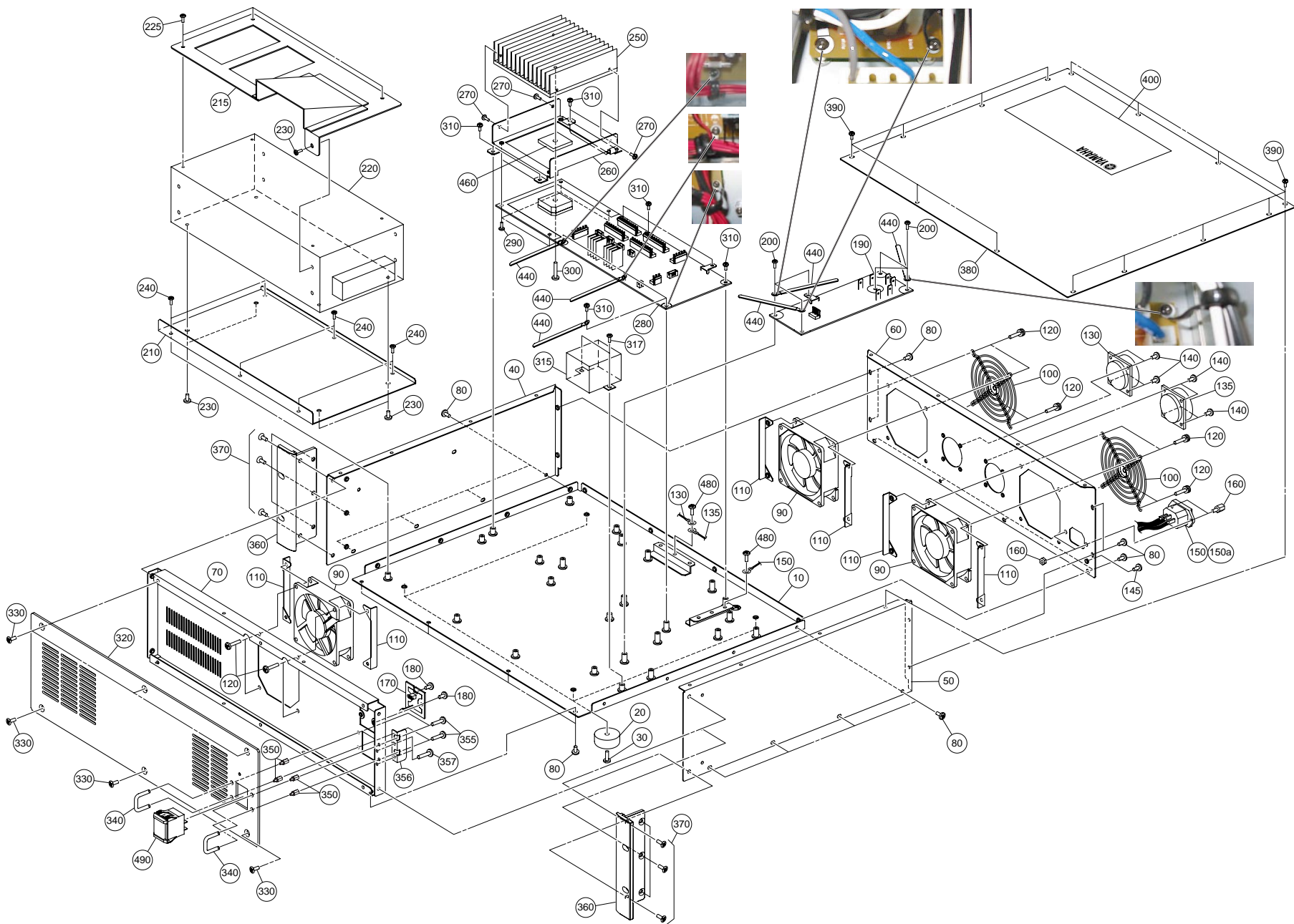

● Top view

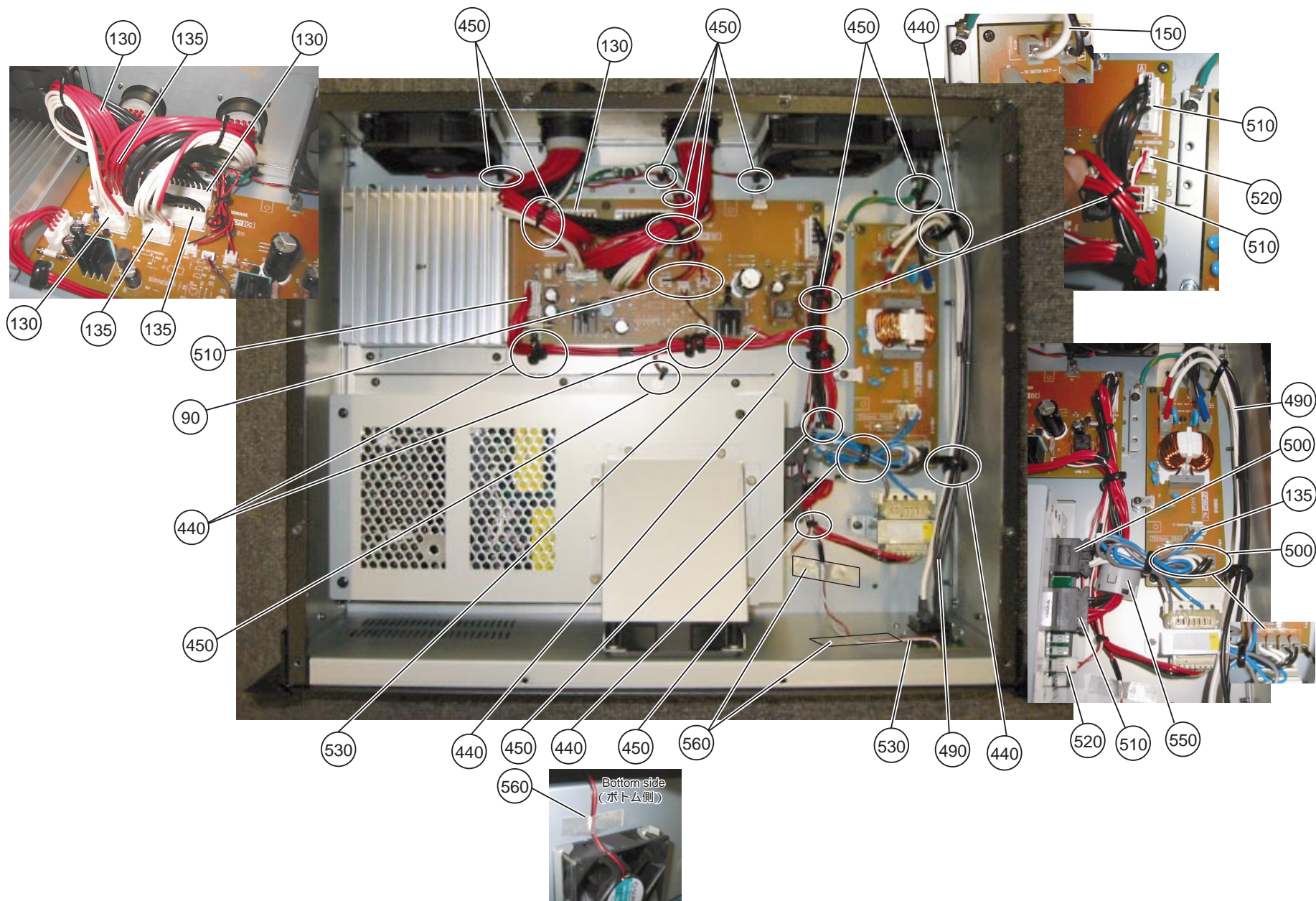

REF NO.	PART NO.	DESCRIPTION	部 品 名	REMARKS	QTY	RANK
	--	OVERALL ASSEMBLY	総 組 立	PW800W		
	--	Overall Assembly	総 組 立	(WB67810)		
* 10	WB678400	Bottom	ボトム加工上り			
20	CB806590	Leg Black	アンブレグ		4	03
30	EG340190	Bind Head Tapping Screw-B	4.0X8 MFZN2BL + バインド B タイ		4	01
40	V5204100	Side Panel L	LEFT サイドパネル L			10
50	V5204000	Side Panel R	RIGHT サイドパネル R			10
* 60	WC297900	Rear Panel	リアパネル印刷上がり			
70	--	Sub Chassis	サブシャーシ	(WC19330)		
80	EG340190	Bind Head Tapping Screw-B	4.0X8 MFZN2BL + バインド B タイ		20	01
90	V5789100	Motor	DC KDE1208PTS3-6	Fan	3	09
100	VK949100	Fan Guard	FG-08UL PDR-601	ファンガード	2	06
110	V6444900	Fan Guide	FANガイド		6	02
120	VB671600	Pan Head Screw	SP 4.0X20 MFZN2BL + ナベ小ネジ		12	01
* 130	WC384000	Receptacle Assembly	VH 5P/9P/10P	DC OUTPUT レセプタクル A s s ' y		
* 135	WC400600	Receptacle Assembly	VH 5P/9P/10P	DC PARALLEL INPUT レセプタクル A s s ' y		
140	EP600190	Bind Head Tapping Screw-B	3.0X8 MFZN2BL + バインド B タイ		8	01
145	EG340360	Bind Head Screw	4.0X8 MFZN2BL + バインド小ネジ			01
150	--	AC Inlet Assembly	AC INLET&FASTON	(WC62190)		
△ 150a	V5065200	AC Inlet	3P M1908-C	AC IN ACインレット 3P		03
160	V5600300	Support		サポ - ト	2	05
* 170	WB788900	Circuit Board	LED (PWCOM)	LEDシ - ト		
180	EP600230	Bind Head Tapping Screw-B	3.0X6 MFZN2BL + バインド B タイ	(WB75820)	2	01
* 190	WB788700	Circuit Board	AC (PWCOM)	ACシ - ト		
200	EP600230	Bind Head Tapping Screw-B	3.0X6 MFZN2BL + バインド B タイ	(WB75820)	6	01
210	--	Angle, SW Power		SW電源取付け金具		
215	--	Angle, Window		ウインドアングル	(WC18640) (WD01450)	
△ * 220	WC308600	Power Supply Unit	ADA1000F-24-YMH	電源ユニット		
225	VB659000	Bind Head Screw	3.0X8 MFZN2BL + バインド小ネジ		3	01
230	EG340360	Bind Head Screw	4.0X8 MFZN2BL + バインド小ネジ		5	01
240	EP600230	Bind Head Tapping Screw-B	3.0X6 MFZN2BL + バインド B タイ		6	01
250	--	Heat Sink	DS 30BS106H-L102	ヒートシンク DS		
260	--	Holder, Heat Sink		ヒートシンク取付け金具	(WD26890) (WC18770)	
270	VB659000	Bind Head Screw	3.0X8 MFZN2BL + バインド小ネジ		3	01
* 280	WB788800	Circuit Board	DC (PWCOM)	DCシ - ト	(WB75820)	
290	EP600230	Bind Head Tapping Screw-B	3.0X6 MFZN2BL + バインド B タイ		4	01
300	VB671600	Pan Head Screw	SP 4.0X20 MFZN2BL + ナベ小ネジ			01
310	EP600230	Bind Head Tapping Screw-B	3.0X6 MFZN2BL + バインド B タイ		11	01
△ 315	X3659A00	Power Transformer	H,B E (INDI)	電源トランス (INDI)		09
317	EP600230	Bind Head Tapping Screw-B	3.0X6 MFZN2BL + バインド B タイ		2	01
* 320	WC298100	Front Panel		フロントパネル印刷		
330	VS153600	Oval Head Screw	4.0X8 MFZN2BL + 丸皿小ネジ		6	01
* 340	WC656700	Handle Guard	J20141A0000	ハンドルガード	2	
* 350	WD391600	Spacer	M2.6X8 Hex. Type	スペーサ 6 角型	4	
355	EE620120	Pan Head Screw	2.6X4 MFZN2BL + ナベ小ネジ		4	01
356	--	Guide Plate		ガイドプレート	(WD18530)	
357	EP600230	Bind Head Tapping Screw-B	3.0X6 MFZN2BL + バインド B タイ		2	01
360	V7447100	Mount Bracket	3U	マウントブラケット	2	09
370	VS153600	Oval Head Screw	4.0X8 MFZN2BL + 丸皿小ネジ		10	01
380	V4588000	Top Cover		トップカバー		12
390	EG340190	Bind Head Tapping Screw-B	4.0X8 MFZN2BL + バインド B タイ		14	01
400	--	Label		ラベルメイバン	(WC30600)	
440	CB817510	Cord Binder	S-14B	束線止め	6	03
450	CB069250	Cord Holder	BK-1	インシュロックタイ	11	01
460	VN369700	Insulation Sheet	BFG-20AD	放熱シート		02
△ 480	EG340360	Bind Head Screw	4.0X8 MFZN2BL + バインド小ネジ		2	01
* 490	WC597900	Switch Assembly	SW&FASTON	スイッチ A s s ' y	POWER ON/OFF	
* 500	WC597700	Connector Assembly	ADA1K 6P	束線		
* 510	WC597600	Connector Assembly	ADA1K 10P VH 6P/7P	束線		
* 520	WC597800	Connector Assembly	ADA1K 3P PH 5P	束線		
* 530	WD269000	Connector Assembly	PH&PH 2P 400L	束線 # 2 8		
550	VV910400	Clamp Filter	ZCAT3035-1330	クランプフィルタ		07
560	VA126100	Adhesive Tape	12X50	粘着テープ	3	03
		ACCESSORIES	付 属 品			
△ 5600500	V5600500	Holder, AC Cord	J UL	I / O ロック J _ U L	J,U,V	07
△ 5600800	V5600800	Holder, AC Cord	BS CE	I / O ロック B S _ C E	H,B,K,W	07
△ 5800000	V5800000	AC Cord	J 3P 15A	電源コード加工品	J	09
△ 5068000	V5068000	AC Cord	U/C 3P 13A	電源コ - ド	U,V	09
△ 5067700	V5067700	AC Cord	CE 3P 10A	電源コ - ド	H,K,W	08
△ 6190800	V6190800	AC Cord	BS	電源コ - ド	B	10

*: New Parts

RANK: Japan only

ELECTRICAL PARTS (電気部品)

REF NO.	PART NO.	DESCRIPTION		部 品 名	REMARKS	QTY	RANK
		ELECTRICAL PARTS		電 気 部 品	PW800W		
*	WB788700	Circuit Board	AC (PWCOM)	A C シ ー ト	(WB75820)(X4589B0)		
*	WB788800	Circuit Board	DC (PWCOM)	D C シ ー ト	(WB75820)(X4589B0)		
*	WB788900	Circuit Board	LED (PWCOM)	L E D シ ー ト	(WB75820)(X4589B0)		
*	WB788700	Circuit Board	AC (PWCOM)	A C シ ー ト	(WB75820)(X4589B0)		
*	WB788800	Circuit Board	DC (PWCOM)	D C シ ー ト	(WB75820)(X4589B0)		
*	WB788900	Circuit Board	LED (PWCOM)	L E D シ ー ト	(WB75820)(X4589B0)		
*	WC623400	LED Spacer	LH-3-15	L E D ス ペ ー サ ー			
	EG330380	Bind Head Screw	3.0X10 MFZN2BL	+ バ イ ン ド 小 ネ ジ		2	01
	--	Silicon Grease	G-746	シ リ コ ン グ リ ー ス	(0412125)		
	VM679600	Diode Spacer	GBPC2504	ダ イ オ ー ド ス ペ ー サ ー			06
	--	Jumper Wire	0.55	ジ ャ ン パ ー 線	(VA07890)		
⚠	C1	V9908300	Capacitor	0.220 275V U.C.S	規 格 認 定 コ ン ミ ッ タ ー		
⚠	C2	V9908300	Capacitor	0.220 275V U.C.S	規 格 認 定 コ ン ミ ッ タ ー		
⚠	C3	V3311600	Capacitor	0.010 250V J.U.C.S	規 格 認 定 コ ン ミ ッ タ ー		01
	C5	FH223470	Ceramic Capacitor-E	0.0047 500V M	セ ラ コ ン E		01
	C6	FH223470	Ceramic Capacitor-E	0.0047 500V M	セ ラ コ ン E		01
	C7	WA163300	Electrolytic Cap.-HD	220.00 35.0V	ケ ミ コ ン H D		01
	C8	FH223470	Ceramic Capacitor-E	0.0047 500V M	セ ラ コ ン E		01
	C9	FH223470	Ceramic Capacitor-E	0.0047 500V M	セ ラ コ ン E		01
	C10	UR868220	Electrolytic Cap.	220.00 50.0V	ケ ミ コ ン		
	C11	WA163300	Electrolytic Cap.-HD	220.00 35.0V	ケ ミ コ ン H D		01
	C12	FG644100	Ceramic Capacitor-F	0.0100 50V Z	セ ラ コ ン (F)		01
	C13	UR739470	Electrolytic Cap.	4700 16.0V	ケ ミ コ ン		02
⚠	C14	V3311600	Capacitor	0.010 250V J.U.C.S	規 格 認 定 コ ン ミ ッ タ ー		01
	C15	UR867470	Electrolytic Cap.	47.00 50.0V	ケ ミ コ ン		01
⚠	C17	V7682400	Capacitor	1000P 250V J.U.C.S	規 格 認 定 コ ン ミ ッ タ ー		01
⚠	-20	V7682400	Capacitor	1000P 250V J.U.C.S	規 格 認 定 コ ン ミ ッ タ ー		01
	C21	VF611200	Monolithic Ceramic Cap.	0.100 50V Z	積 層 セ ラ コ ン		02
	C22	UI565330	Electrolytic Cap.	0.33 50.0V	ケ ミ コ ン		01
	C26	FG613150	Ceramic Capacitor-B	1500P 50V K	セ ラ コ ン (B)		01
	C27	WA163300	Electrolytic Cap.-HD	220.00 35.0V	ケ ミ コ ン H D		01
	CN2	VB389800	Connector Base Post	PH 2P TE	コ ネ ク タ ベ ー ス ポ ス ト		01
	CN6	LB932030	Base Post Connector	VH 3P TE	ベ ー ス ポ ス ト		01
	CN7	LB932060	Base Post Connector	VH 6P TE	ベ ー ス ポ ス ト		01
	CN8	LB932070	Base Post Connector	VH 7P TE	ベ ー ス ポ ス ト		01
	CN9	VB390100	Connector Base Post	PH 5P TE	コ ネ ク タ ベ ー ス ポ ス ト		01
	CN10	LB932030	Base Post Connector	VH 3P TE	ベ ー ス ポ ス ト		01
	CN11	LB932090	Base Post Connector	VH 9P TE	ベ ー ス ポ ス ト		01
	CN12	LB932100	Base Post Connector	VH 10P TE	ベ ー ス ポ ス ト		02
	CN13	VB389900	Connector Base Post	PH 3P TE	コ ネ ク タ ベ ー ス ポ ス ト		01
	CN14	VB389800	Connector Base Post	PH 2P TE	コ ネ ク タ ベ ー ス ポ ス ト		01
	CN15	LB932050	Base Post Connector	VH 5P TE	ベ ー ス ポ ス ト		01
	CN16	LB932090	Base Post Connector	VH 9P TE	ベ ー ス ポ ス ト		01
	CN17	LB932100	Base Post Connector	VH 10P TE	ベ ー ス ポ ス ト		02
	CN18	VB389900	Connector Base Post	PH 3P TE	コ ネ ク タ ベ ー ス ポ ス ト		01
	CN19	LB932050	Base Post Connector	VH 5P TE	ベ ー ス ポ ス ト		01
	CN21	VB389900	Connector Base Post	PH 3P TE	コ ネ ク タ ベ ー ス ポ ス ト		01
*	D1	WB880800	Diode	10EDA40-TA2B5 52	ダ イ オ ー ド		
*	-3	WB880800	Diode	10EDA40-TA2B5 52	ダ イ オ ー ド		
	D4	V4096300	Diode	RL 10Z LFA4	ダ イ オ ー ド		01
*	D5	WB880800	Diode	10EDA40-TA2B5 52	ダ イ オ ー ド		
*	D6	WB880800	Diode	10EDA40-TA2B5 52	ダ イ オ ー ド		
*	D8	WB880800	Diode	10EDA40-TA2B5 52	ダ イ オ ー ド		
	DB1	IH001120	Diode Stack	S2VB20 2.0A 200V	ダ イ オ ー ド ス タ ッ ク		03
	DB2	VP591700	Diode Stack	GBPC3504 35A 400V	ダ イ オ ー ド ス タ ッ ク		07
⚠	F2	WC423800	Fuse	T H 2.00A US 250V	ヒ ュ ー ズ		
	IC1	XY455A00	IC	PQ1CG21H2FZ	I C	REGULATOR	04
	IC2	V8100500	Photo Coupler	TLP421 GR	フ ォ ト カ プ ラ		01
	K1	--	Heat Sink	PUE16-25 P17.5 PN4	ヒ ー ト シ ン ク	(WD27830)	
	K2	BA808520	Heat Sink	T220M 25L	ヒ ー ト シ ン ク		03
	K3	--	Earth Plate		ア ー ス プ レ ー ト	(WA20680)	
	K4	VD541800	Fasten Tub	250 170267-1	フ ェ ス ト ン タ ブ		01
	-13	VD541800	Fasten Tub	250 170267-1	フ ェ ス ト ン タ ブ		01
	K14	--	Earth Plate		ア ー ス プ レ ー ト	(WA20680)	
⚠	L1	WD119300	Coil	SC-15-10J	S C コ イ ル		
	L2	VU096400	Coil	ELC10E391 390uH	コ イ ル 3 9 0 U H		04
	LD1	VR080300	LED Green	SLR-342MG3F	L E D	POWER Indicator	01
	R1	VC748400	Metal Oxide Film Resistor	2.2K 1W J	酸 化 金 属 被 膜 抵 抗		01

*: New Parts

RANK: Japan only

REF NO.	PART NO.	DESCRIPTION		部 品 名	REMARKS	QTY	RANK
R2	VC748400	Metal Oxide Film Resistor	2.2K 1W J	酸化金属被膜抵抗			01
R3	HF757100	Carbon Resistor	10.0K 1/4 J	カーボン抵抗			01
R4	HF757100	Carbon Resistor	10.0K 1/4 J	カーボン抵抗			01
R5	HF755560	Carbon Resistor	560.0 1/4 J	カーボン抵抗			01
R6	HF757100	Carbon Resistor	10.0K 1/4 J	カーボン抵抗			01
R7	VC754700	Metal Oxide Film Resistor	2.2 2W J	酸化金属被膜抵抗			01
R9	HF757220	Carbon Resistor	22.0K 1/4 J	カーボン抵抗			01
* R10	VC326700	Metal Film Resistor	1.2K 1/4 F	金属被膜抵抗			01
R11	VC328800	Metal Film Resistor	10.0K 1/4 F	金属被膜抵抗			01
R24	VC746800	Metal Oxide Film Resistor	560.0 1W J	酸化金属被膜抵抗			01
TR1	VE198700	Transistor	2SA1145 O,Y	トランジスタ			01
TR2	VC614000	Transistor	2SB1274 R,S	トランジスタ			02
TR3	IC1815M0	Transistor	2SC1815 Y,GR	トランジスタ			01
-5	IC1815M0	Transistor	2SC1815 Y,GR	トランジスタ			01
ZD1	VQ554500	Zener Diode	MTZJ8.2B 8.2V	ツェナーダイオード			01
⚠ *	WC308600	Power Supply Unit	ADA1000F-24-YMH	電源ユニット			
⚠	X3659A00	Power Transformer	H,B E (INDI)	電源トランス (I N D I)			09
	V5789100	Motor	DC KDE1208PTS3-6	D C ファン モーター	Fan	3	09
⚠	V5065200	AC Inlet	3P M1908-C	A C インレット 3 P	AC IN		03
⚠ *	WC597900	Switch Assembly	SW&FASTON	スイッチ A s s ' y	POWER ON/OFF		
* *	WC384000	Receptacle Assembly	VH 5P/9P/10P	レセプタクル A s s ' y	DC OUTPUT		
	WC400600	Receptacle Assembly	VH 5P/9P/10P	レセプタクル A s s ' y	DC PARALLEL INPUT		

*: New Parts

RANK: Japan only

OVERALL CONNECTOR CIRCUIT DIAGRAM (PW800W)

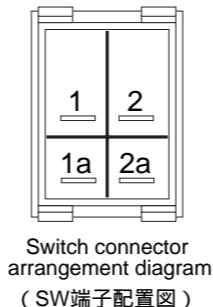
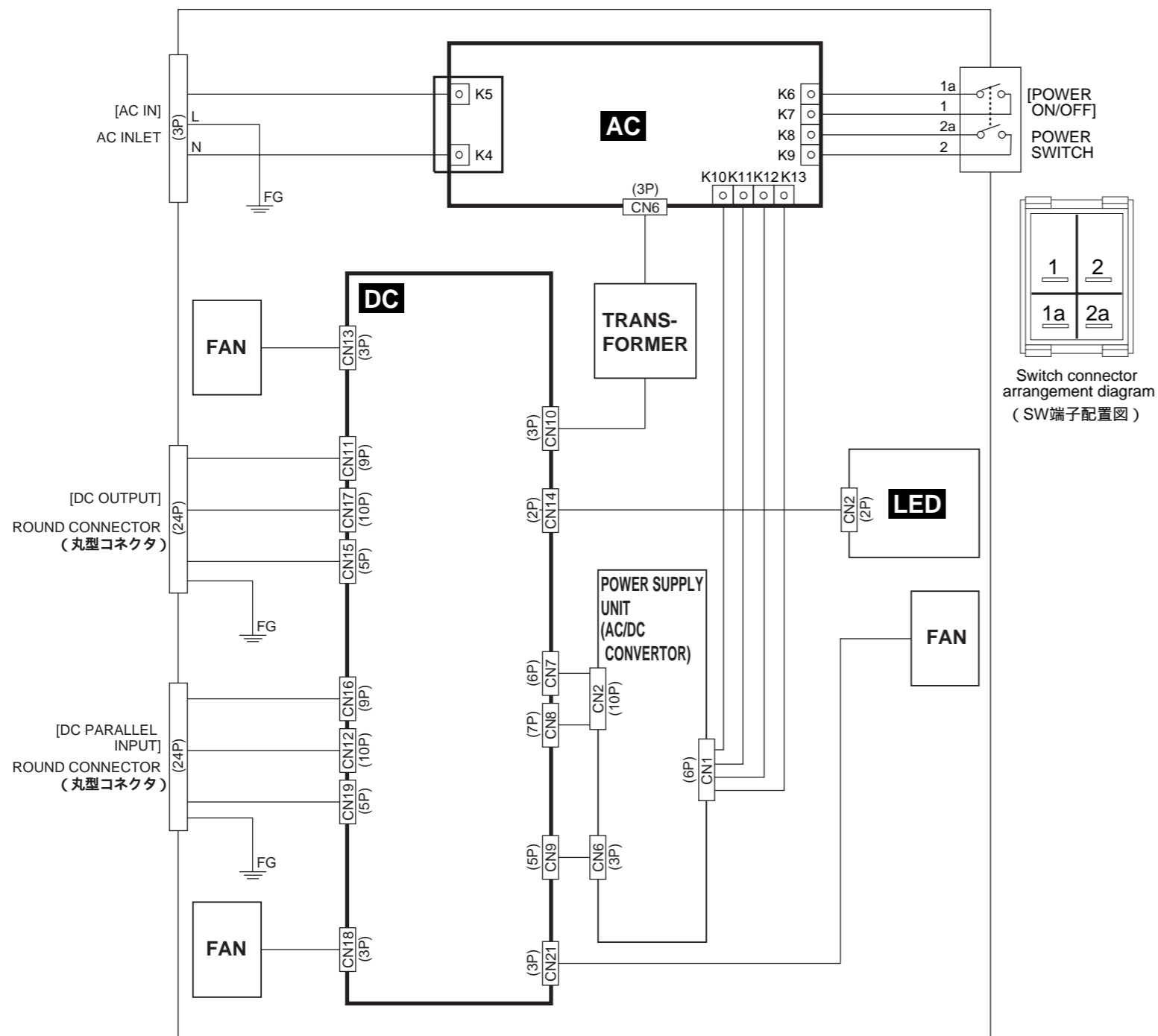

NOTE: Characters in the brackets "[]" indicate the printing on the panel.
 ([]内はパネル上の印字を示します。)
 Double reference marks " " indicate that the connections are show on the right in detail.
 (印部分の接続は右側に詳細を示します。 その他の接続はコネクタの両端で全ピン1対1の対応です。)
 The letter "K" with a number at the right indicates a faston tab.
 (K* * はファストンタブを示します。)

Circuit Board name (シート名)	CN number (CN番号)	PIN number (ピン番号)	Circuit Board name (シート名)	CN number (CN番号)	PIN number (ピン番号)		
AC Circuit Board		K10	AC/AD CONVERTOR (POWER SUPPLY)	CN1	A1		
		K11			B2		
		K12			A3		
		K13			B4		
AC/DC CONVERTOR (POWER SUPPLY)	CN2	B1	DC Circuit Board	CN7	1		
		B2			2		
		B3			3		
		A1			4		
		A2			5		
		ROUND CONNECTOR (丸型コネクタ) [DC OUTPUT]		A3	DC Circuit Board	CN11	1
				A4			2
				A5			3
				B4			4
				B5			5
ROUND CONNECTOR (丸型コネクタ) [DC PARALLEL INPUT]		1	DC Circuit Board	CN17	1		
		2			2		
		3			3		
		4			4		
		5			5		
		6			6		
		7			7		
		8			8		
		9			9		
		10			1		
		11	2				
		12	3				
		13	4				
		14	5				
		15	6				
		16	7				
		17	8				
		18	9				
		19	1				
		20	2				
		21	3				
		22	4				
		23	5				
		24	Earth lag (アースラグ)				
ROUND CONNECTOR (丸型コネクタ) [DC PARALLEL INPUT]		1	DC Circuit Board	CN16	1		
		2			2		
		3			3		
		4			4		
		5			5		
		6			6		
		7			7		
		8			8		
		9			9		
		10			1		
		11	2				
		12	3				
		13	4				
		14	5				
		15	6				
		16	7				
		17	8				
		18	9				
		19	1				
		20	2				
		21	3				
		22	4				
		23	5				
		24	Earth lag (アースラグ)				

NOTE: Pin on the same line are connected to each other.
 (同一のピン同士が接続されます。)
 Pins which are not to be connected are not shown above.
 (接続がないピンについては、上記に表していません。)
 Characters in the brackets "[]" indicate the printing on the panel.
 ([]内はパネル上の印字を示します。)

28CA2-8831513-02

H G F E D C B A

OVERALL CIRCUIT DIAGRAM (PW800W) PW800W

1
2
3
4
5
6

POWER SUPPLY UNIT CONNECTOR

LED
Voltage Adjust
CN6 CN5 CN4 CN2 CN1

AC INLET

AC

POWER SUPPLY UNIT (AC/DC CONVERTOR)

DC

REGULATOR

Photo Coupler

LED

TO RECEPTACEL Assy (OUTPUT)

TO RECEPTACEL Assy (INPUT)

TO RECEPTACEL Assy (OUTPUT)

TO RECEPTACEL Assy (INPUT)

TO RECEPTACEL Assy (INPUT)

TO FAN (Rear R)

TO FAN (Rear L)

TO FAN (Front)

TO RECEPTACEL Assy (OUTPUT)

TO RECEPTACEL Assy (INPUT)

CN4: N.C
CN5: N.C

POWER TRANSFORMER (Primary) (Secondary)

WARNING
Components having special characteristics are marked Δ and must be replaced with parts having specification equal to those originally installed.

規格認定コン : Capacitor (規格認定コン)
(金被) : Metal Film Resistor (金属被膜抵抗)
(酸金) : Metal Oxide Film Resistor (酸化金属被膜抵抗)
(セ) : Ceramic Capacitor (セラコン)

Note : See parts list for details of circuit board component parts.
注 : シートの部品詳細はパーツリストをご参照ください。

28CC1-8831318 Δ 4

<p>•PQ1CG21H2FZ(XY455A00) REGULATOR DC: IC1</p> <p>1: V in 2: V out 3: COM 4: O adj 5: ON/OFF</p>	<p>•10EDA40-TA2B5 (WB880800) DIODE DC: D1-3, 5, 6, 8</p> <p>1: ANODE 2: CATHODE</p>
<p>•RL-10Z LFA4 (V4096300) DIODE DC: D4</p> <p>1: ANODE 2: CATHODE</p>	<p>•MTZJ 8.2B 8.2V (VQ554500) ZENER DIODE DC: ZD1</p> <p>1: ANODE 2: CATHODE</p>
<p>•S2VB20(IH001120) DIODE STACK DC: DB1</p>	<p>•GBPC3504(VP591700) DIODE STACK DC: DB2</p>

* When PM5D or PM5D-RH is connected, adjust VR601 on the power supply unit so that the output voltage becomes +24.5V \pm 0.5V.
PM5DまたはPM5D-RHを接続した場合、出力電圧が+24.5V \pm 0.5 Vになるように電源ユニットのVR601を調整します。

POWER SUPPLY LINK CABLE

PSL120

PARTS LIST

Notes : DESTINATION ABBREVIATIONS

A : Australian model	M : South African model
B : British model	O : Chinese model
C : Canadian model	Q : South-east Asia model
D : German model	T : Taiwan model
E : European model	U : U.S.A. model
F : French model	V : General export model (110V)
H : North European model	W : General export model (220V)
I : Indonesian model	N,X : General export model
J : Japanese model	Y : Export model
K : Korean model	

■ WARNING

Components having special characteristics are marked  and must be replaced with parts having specification equal to those originally installed.

 印の部品は、安全を維持するために重要な部品です。交換する場合は、安全のために必ず指定の部品をご使用ください。

- The numbers "QTY" show quantities for each unit.
- The parts with "--" in "PART NO." are not available as spare parts.
- This mark "}" in the REMARKS column means these parts are interchangeable.
- The second letter of the shaded (■) part number is O, not zero.
- The second letter of the shaded (■) part number is I, not one.
- 部品価格ランクは、変更になることがあります。
- QTY欄に記されている数字は、各ユニット当たりの使用個数です。
- PART NO.が"--"の部品は、サービス用部品として準備されておりません。
- REMARKS欄の「}」マークの部品は、併用部品です。
- 網掛けの付いたPART NO. の2番目の文字は「ゼロ」ではなく、「オー」です。
- 網掛けの付いたPART NO. の2番目の文字は「イチ」ではなく、「アイ」です。

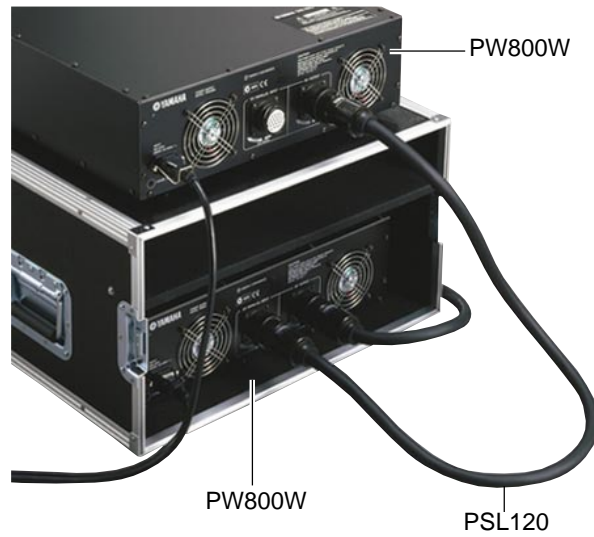

■ PARTS LIST (パーツリスト)

REF NO.	PART NO.	DESCRIPTION	部 品 名	REMARKS	QTY	RANK
	--	COMPLETE ASSEMBLY	同 梱 品 セ ッ ト	PSL120		
	--	Complete Assembly	同 梱 品 セ ッ ト	J (WD19450)		
	--	Complete Assembly	同 梱 品 セ ッ ト	Y (WD19460)		
* 30	WD197700	DC Power Supply Cable	電 源 ケ ー ブ ル			
50	--	Label	ラ ベ ル	(WD25510)		
		UL2464 #16X24 L=1200				
		PW CABLE				

*: New Parts

RANK: Japan only