



**WORLD HEADQUARTERS
CANADA**

Yorkville Sound
550 Granite Court
Pickering, Ontario
L1W-3Y8 CANADA

Voice: (905) 837-8481
Fax: (905) 837-8746

U.S.A.

Yorkville Sound Inc.
4625 Witmer Industrial Estate
Niagara Falls, New York
14305 USA

Voice: (716) 297-2920
Fax: (716) 297-3689



Quality and Innovation Since 1963
Printed in Canada

AUDIOPRO
3000
HIGH EFFICIENCY STEREO POWER AMPLIFIER

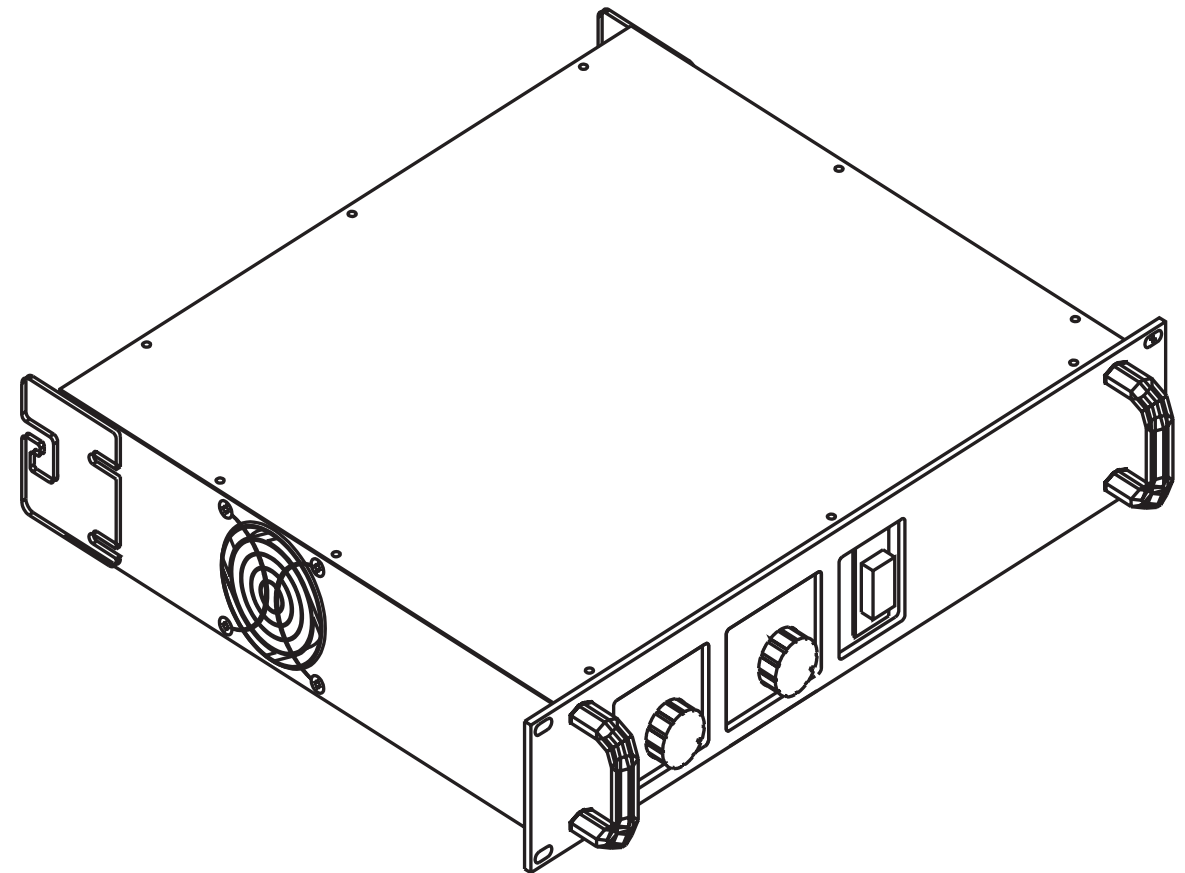

SERVICE MANUAL

IMPORTANT SAFETY INSTRUCTIONS



INSTRUCTIONS PERTAINING TO A RISK OF FIRE, ELECTRIC SHOCK, OR INJURY TO PERSONS.

INSTRUCTIONS RELATIVES AU RISQUE DE FEU, CHOC ÉLECTRIQUE, OU BLESSURES AUX PERSONNES.

CAUTION:
DO NOT REMOVE COVER (OR BACK). NO USER SERVICEABLE PARTS INSIDE.
REFER SERVICING TO QUALIFIED SERVICE PERSONNEL.

AFIN DE RÉDUIRE LES RISQUE DE CHOC ÉLECTRIQUE, N'ENLEVEZ PAS LE COUVERT (OU NE CONTIENT AUCUNE PIÈCE RÉPARABLE PAR L'UTILISATEUR).
CONSULTEZ UN TECHNICIEN QUALIFIÉ POUR L'ENTRETIEN.

Read Instructions:

The *Owner's Manual* should be read and understood before operation of your unit. Please, save these instructions for future reference.

Packaging:

Keep the box and packaging materials, in case the unit needs to be returned for service.

Warning:

When using electric products, basic precautions should always be followed, including the following:

Power Sources:

Your unit should be connected to a power source only of the voltage specified in the owners manual or as marked on the unit. This unit has a polarized plug. Do not use with an extension cord or receptacle unless all three blades can be fully inserted to prevent blade exposure. Precautions should be taken so that the grounding scheme on the unit is not defeated.

Power Cord:

The AC supply cord should be routed so that it is unlikely that it will be damaged. If the AC supply cord is damaged **DO NOT OPERATE THE UNIT.**

Service:

The unit should be serviced only by qualified service personnel.

Veillez lire le manuel:

Il contient des informations qui devraient être comprises avant l'opération de votre appareil. Conservez S.V.P. ces instructions pour consultations ultérieures

Emballage:

Conservez la boîte au cas où l'appareil devrait être retourner pour réparation.

Warning:

Attention: Lors de l'utilisation de produits électrique, assurez-vous d'adhérer à des précautions de bases incluant celle qui suivent:

Alimentation:

L'appareil ne doit être branché qu'à une source d'alimentation correspondant au voltage spécifié dans le manuel ou tel qu'indiqué sur l'appareil. Cet appareil est équipé d'une prise d'alimentation polarisée. Ne pas utiliser cet appareil avec un cordon de raccordement à moins qu'il soit possible d'insérer complètement les trois lames. Des précautions doivent être prises afin d'éviter que le système de mise à la terre de l'appareil ne soit désengagé.

Cordon d'alimentation:

Évitez d'endommager le cordon d'alimentation. **N'UTILISEZ PAS L'APPAREIL** si le cordon d'alimentation est endommagé.

Service:

Consultez un technicien qualifié pour l'entretien de votre appareil.

AUDIOPRO AP-3000 SERVICE MANUAL

M1012 "THE INPUT BOARD"

The input board processes the audio signal from the input jacks to the voltage amplifier board, (M1011).

Each channel consists of a balanced gain stage, defeatable bass boost filter, and a preemphasis filter network.

The balanced input, (XLR Jack) and unbalanced input (phone jack) are wired in parallel to the input of a balanced operational amplifier, (U1). The gain of this stage is 1.6 (4dB) balanced and 1.6 (4dB) unbalanced. Resistors R1, R5 along with capacitors C1 and C2 form a radio interference elimination filter.

Switch S1 selects a flat or bass boosted frequency response. The bass boost filter provides a 20Hz high pass, high Q filter response with a +4dB peak at 55Hz. The filter consists of a tee network on the input of U1A along with R9, R10, R11, C5 and C6. The gain is 1 (0dB) in the passband, (above 100Hz).

Operational amplifier U3B is a high pass shelving filter with a +2dB shelf above 20KHz. This filter provides the pre-emphasis required to obtain a flat frequency response (to 20KHz) on the power amplifier output at full power.

M1011 "VOLTAGE AMPLIFIERS AND SYSTEM CONTROL"

This board contains:

- Voltage amplifiers to drive the current amplifiers on the M1002 boards.
- The front panel volume control circuitry.
- The EMS control system with its associated circuits: Pre clipping and line current sensing heater circuits.
- Clip and activity LED's. Driver circuitry for the amplifier disable relay (used during amplifier turn on, turn off, thermal shutdown and current limiting).

Circuit Explanation:

Refer to the schematic of M1011 as the sections of the circuit are explained.

The audio signal enters the board from M1012 through connector MS4. The two channels are marked "L" and "R" for left and right. The signals are to be considered as differential sources and therefore are marked as L+, L-,R+ and R-. Since the left channel has the same topology as the right channel we will only look at the left channel.

The signal ("L+") at the terminal block (MS4) passes through the front panel level control (P1) and the desired level enters the inverting input of U1.

Op amp U1 is an inverting amplifier with a set gain of 2.40 (7.6dB). Built around U1 is a dual purpose circuit controlled by a voltage divider consisting of R15, R16, R17, R18, R19, R20 and R21. The voltage divider sets two reference levels, (HDRM & CLP). Reference voltage levels vary with the voltage levels on the +/-100VDC supply rails. As the amplifier's output is loaded, the supply rails voltage decreases and so do the reference levels.

Transistors Q1, Q3 the surrounding resistors provide a pre-clipping function that tracks the supply rails through the HDRM voltage reference and clips the audio signal at approximately 11.2V pk. The clip LED indicator circuit is connected through D1 and D2 to the output of U1, The bases of Q2 and Q4 are connected to the "CLP" reference voltage, and when the peak output voltage of U1 (+/-Vp) is enough to forward bias the transistor junctions, Q2 or Q4 will trigger the clip led circuit (Q5), and eliminate the clip LED.

The audio signal on the output of U1 enters U3 through R43 and RV1. Under normal operating conditions the gain of U3 is 1(0dB). The signal then passes through U2 to the voltage amplifier.

VOLTAGE AMPLIFIER:

The voltage amplifier amplifies the audio signal's voltage from 6.5 volts peak (at the output of U2) to approximately 70v peak which is required to drive the current amplifier board M1002. M1002 provides the current required for the 70v peak signal to drive 1200 watts into 2 ohms out of the binding posts.

Before the circuit is described in detail here is a quick rundown on the signal's path through the voltage amplifier stage. Refer to the schematic of M1011. Let's consider that a positive going AC signal is present @ test point 3. The positive going signal will turn on the positive side of the voltage amplifier. The signal at test point 3 turns on Q12 (through R40, D14 and D13). The collector of Q12 pulls down on the base of Q14, turns this transistor on further and allows a greater current to flow out of Q14's collector. This increase in current passes through Q15 and it's collector to emitter voltage drop decreases. The collector of Q15 now being more positive in voltage turns the base of Q18 on causing an increase in Q18's collector current resulting in test point 5 going positive.

As the positive side of the amplifier was turning on the negative side would have been turning off. This is how test point 5 was able to move positive following the input signal. The reverse would hold true if a negative going signal was present on the input of the voltage amplifier.

CIRCUIT DESCRIPTION:

The voltage amplifier is a mirrored image with circuitry connected to the positive power supply rail being identical (but opposite polarity) to the circuitry connected to the negative power supply rail.

For this reason we will look in detail at the positive side of the amplifier.

The audio signal enters the voltage amplifier at test point 3. The signal passes through R40, D14 and D13 to the base of Q12. Diodes D13 and D14 set up the DC bias on Q12 to approximately 0.6 mA.

The first voltage gain stage consists of Q12 along with the resistor chain on its collector and the emitter resistor (R44).

Transistor Q12 drives the base of Q14 through the resistor chain. A DC current of approximately 6 mA should flow through the collector of Q14. The voltage drop across Q14 remains constant and is derived from the voltage drop across the voltage reference Q20, resistor R58, and the base/emitter junction of Q15. This total voltage should equal approximately 3 VDC. Transistor Q14 is the second gain stage and its output current flows through Q15. Transistor Q15 is a common base stage with the collector driving the base of output buffer Q18.

Diode D17 is a clamping diode that prevents the maximum peak of the audio signal from coming within 4V of the 100 VDC rail. This is to prevent the output current amplifier (board M1002) from going into saturation during clipping and therefore having storage delay problems.

Transistor Q18 buffers the high impedance present on the collector of Q15. The output of the buffer provides a low output impedance at test point 5 and is current limited to 38mA through the clamping action of D19, D20 and D23. The signal at TP-5 drives the current amp board M1002.

DC offset on the amplifier's output is corrected by operational amplifier U2. The DC offset forms a current through R54, R14 and is blocked by C5 giving a DC offset correction gain of -1.

The activity L.E.D. function is a simple charge pump circuit with a transistor that redirects a constant current path through the activity L.E.D.

SHUTDOWN CIRCUIT:

The last circuit on board M1011 is the shutdown relay and its associated drive circuitry. The relay circuit has two possible operating states.

1. Amplifier on under normal operating conditions.
2. Amplifier power switch has just been turned OFF/ON or the amplifier is in current limit protecting the amplifier's output or the amplifier has overheated.

CIRCUIT DESCRIPTION

Here is how the circuit accomplishes these functions. The relay's normally closed contacts short the output of the voltage amplifiers to ground when the power switch is off. When the power switch is turned on, the relay remains off (normally closed) for about 6 seconds. C52 charges to 35V and results in Q37 turning off allowing Q36 to turn on. As Q36 turns on, it connects the negative terminal of the relay's coil (Pin 16) to ground energizing the relay and opening the normally closed contacts.

If prolonged current limiting occurs on the amplifier's output transistors then D50 or D51 (depending on which channel is current limiting) will be forward biased turning on Q38 (from its off state). Now +100VDC appears on the collector of Q38 and through R130 and R128 turn on Q37 therefore turning off Q36 by shorting its base emitter junction. Q36 turning off will turn the relay off and the normally closed contacts (off state) will short the outputs of the voltage amplifiers to ground so as not to continuously stress the amplifier's output transistors. A cycle now occurs. With the voltage amplifiers now disabled there is no signal driving the output transistors (Q14 to Q28) on board M1002.

The current limit circuit on M1002 turns off and D50 and/or D51 are not forward biased and Q38 turns off. Through Q37 and Q36 the relay is turned back on and the voltage amplifiers are now active again, driving the output transistors. If current limiting still occurs, then the same cycle will occur. If the cause of current limiting (low impedance or short on the speaker output terminals) has been removed, then the amplifier will continue to operate normally.

The third operation that the relay provides is "overheat shutdown". If for some reason the fan cannot keep the heatsinks in a safe operating temperature area then the fan control circuit (on board M1013) will deliver through the "kill" signal line a positive current to turn Q37 on and turn Q36 off to turn off the relay and disable the voltage amplifiers. When the temperature of the amplifier has been cooled down by the fan, then the kill signal will disappear and the relay circuit will turn on the relay to resume normal operation. Anytime the relay is in the "protect" mode (due to the abnormal states) then contact pin 8 of the relay will illuminate LD5 (the protect LED on the front panel).

M1002 "CURRENT AMPLIFIER BOARD"

The current amplifier board (M1002) receives a high voltage audio signal from voltage amplifier board (M1011) and provides the current drive necessary to drive speaker cabinets.

The current amplifier is a two tier complimentary output driver design controlled by a complimentary mos-fet stage.

CIRCUIT DESCRIPTION - REFER TO THE SIMPLIFIED SCHEMATIC #1 ON THE FOLLOWING PAGE

SIMPLIFIED SCHEMATIC #1

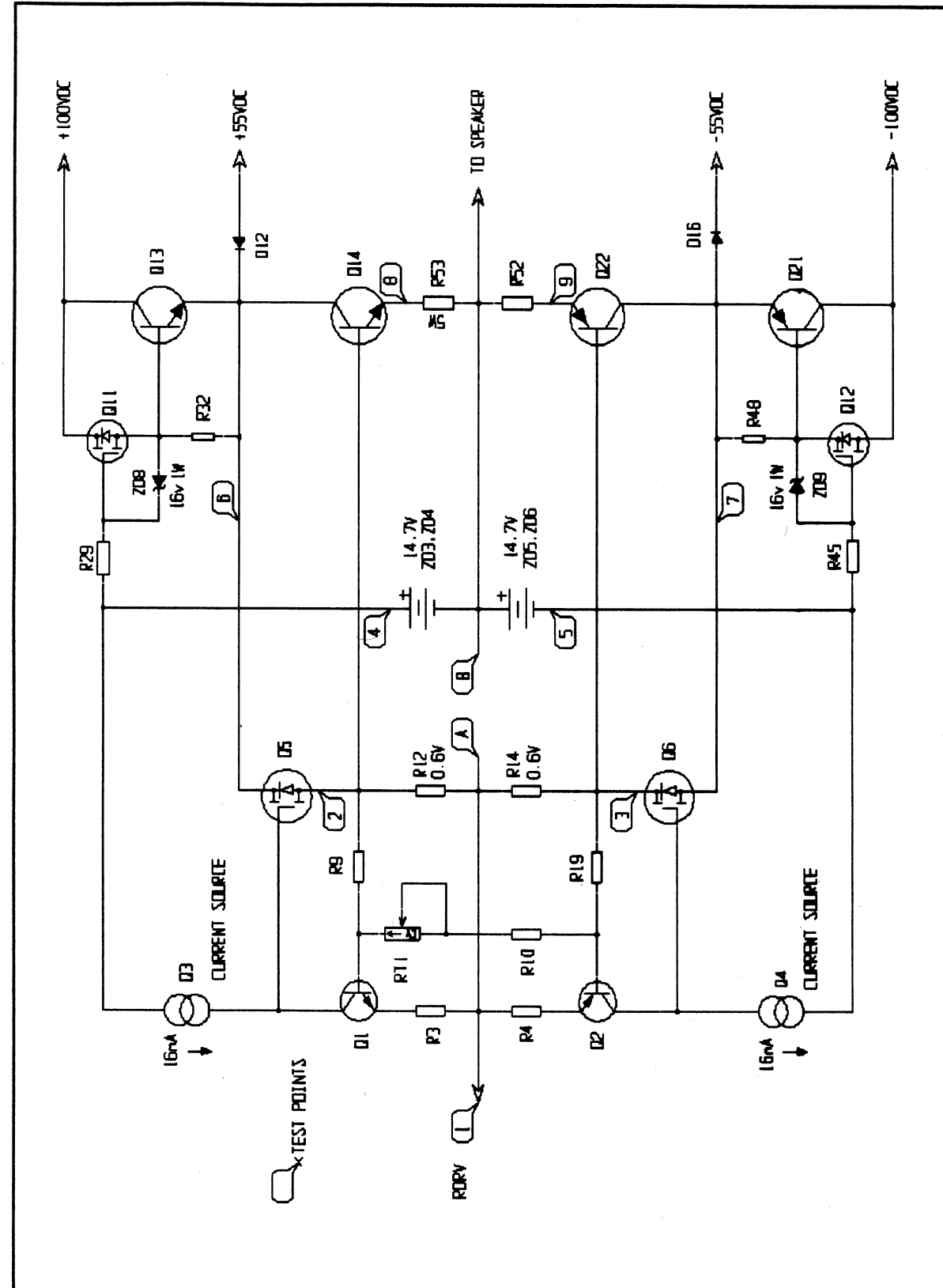

QUIESCENT CONDITION:

This design is class A/B and therefore the output driver transistors must be forward biased to provide low crossover distortion. In most class A/B designs, a diode chain or VBE multiplier is used to control the bias voltage and provide a means of adjusting the bias. This design is different as there isn't a diode chain or VBE multiplier. For simplicity lets consider only the positive side of the current amplifier, that is all parts between the positive power supply rails and the audio signal output/input terminals. The negative side is the same as the positive, except for polarity changes.

To bias Q14, greater than 0.5V is needed from base to emitter, (or for simplicity from base to amplifier output). Points A and B are at the same potential, so consider them to be connected. If this is true then 0.5V from test point 2 to the amplifier output must appear across R12. There must be some way of developing this voltage across R12, and there is using the mos-fet (Q5) driver along with local feedback.

Simplified schematic Fig. #1 shows the biasing circuit. The current needed to develop 0.5V across R12 comes from the source of Q5. When the amplifier is first turned on the current source (Q3) turns on Q5 and current flows through R12 developing a voltage. When this voltage approaches 0.5V Q1 turns on and robs current from the gate of Q5.

This causes Q5 to turn off until the reduced current flowing through Q5 maintains 0.5V across R12. Q1 will turn off slightly causing Q5 to increase its source current. The circuit reaches a point of equilibrium with approximately 0.5V across R12.

Because all output devices are not identical and base emitter voltages vary, some adjustment must be available to slightly adjust the 0.5V across R12. This is accomplished with RT1. RT1 causes Q1 to turn on slightly more or less resulting in Q5 turning on slightly more or less and therefore R12's voltage will be slightly more or less than 0.5v. The proper quiescent current adjustment is 4mV (to be measured between test points 8 and 9).

THE SECOND TIER:

Refer to the simplified schematic Fig. #1 while reading the following text. One way of making an amplifier more efficient is to vary the Power Supply Voltage on the collectors of the output transistors (Q14 & Q22). The lower the voltage from collector to emitter, the lower the device dissipation. During quiescent conditions, there is 55VDC on the collectors of output transistors Q14 and Q22. The peak AC voltage that can appear on the amplifier's output is approximately 95V peak. How can an output transistor deliver a 95V peak when its collector is only at 55VDC? It can if its collector is pulled up to 100VDC as the output signal's peak rises above 55VDC. (refer to Fig. #2). The second tier voltage must remain above the amplifier's output voltage by amount V_m . Therefore the circuitry controlling the second tier voltage must increase the tier voltage before the amplifier's output voltage reaches 55VDC. This leading voltage is necessary to compensate for time lag of the second tier circuit during fast rising amplifier output signals.

The voltage between the amplifier's output and test point 4 is approximately 14.7VDC derived from the voltage drop across ZD3 @ ZD4. We call this voltage the "floating battery" because it floats on top of the output audio signal with point 4 always being 14.7VDC greater than the peak of the output signal. Point 4 drives the gate of mos-fet Q11. Q11 controls the transistors of the upper tier. As Q11 turns on it's source forward biases the base of Q13 and Q13 pulls the collector of Q14 towards the 100 volt rail. The gate to source voltage needed to turn on Q11 is approximately 3.5 volts. When the peak output signal is about 44vp (55v-(14.7v-3.5v)) then Q11 will start to turn on the second tier. The second tier voltage will remain about 11 volts (Vm) above the peak of the output signal to the point of clipping where this voltage is reduced to about 4 volts. Zener ZD8 protects the gate source junction of Q11 and also provides a current path through R29 for the "floating battery".

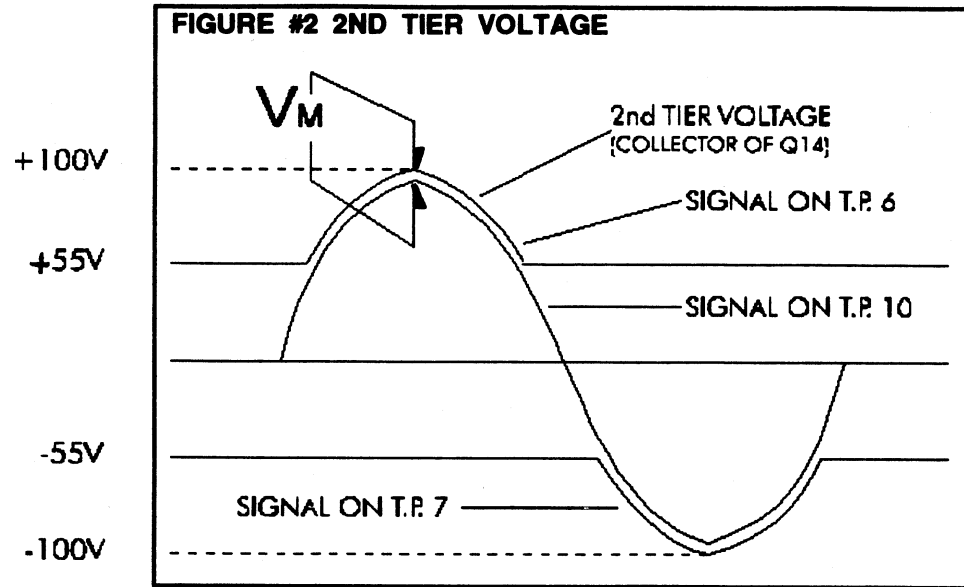

Current Limit Protection Circuitry

To have an amplifier drive 3000 watts into practically any combination of speaker cabinets and know what is a safe load and what is not is a very difficult task. An extensive amount of time was spent on the current limit circuitry so that it may simulate the safe operating area of the output transistors (SOAR curve). No matter how reactive the load may be the phase shift that it presents, along with it's resistive component is used to set the output current limit of the output transistor stage.

Refer to the schematic of board M1002 while reading the following text. The current limit circuitry is a mirrored image with circuitry connected to the positive power supply rail being identical (but opposite polarity) to the circuitry connected to the negative power supply rail. For this reason we will look at the positive side of the circuitry.

Transistor Q9 measures the peak current flowing through resistor R53. The voltage across R53 (as a result of the current flowing through it) is scaled down by R55, R35, R36, R37, D7 and D11- these parts make up the safe operating area along with the time constants of C26, R34, C12 and R26. Fig. #3 shows a waveform of the current that passes through R52 and R53 when the output of the amplifier is shorted to ground. This can only be seen by using an oscilloscope to measure differentially across R52 and R53. The conditions of the measurement are contained on the diagram. During current limit when Q9 turns on it reduces the voltage across R42. R42 is in series with a 16 volt zener (ZD7) and is also in parallel with the junction of Q8. Q8 is normally saturated by the current that flows through R20, ZD7, R42, and R22. When Q9 reduces the voltage across ZD9 and R42 to below 16.6 volts then Q8 turns off allowing a charge to build up on C8 through resistors R24 and R25. If current limiting occurs for a long enough duration to allow C8 to charge to 1.2 volts then Q7 will turn on tripping the relay circuit on board M1011. As soon as the relay is turned off the audio signal will be turned off at the voltage amplifiers and will remain off for about 5 seconds before the relay turns on and allows the audio signal to pass through the amplifier. If a current limit condition is still present then the whole cycle will occur again and repeat until the load conditions on the amplifier's output are safe for the amplifier. When a safe load reappears the amplifier will automatically reset and drive that load (the speaker cabinet). Subwoofers present large inductive loads to the amplifier and are driven at low frequencies where the large current peaks must be tolerated for short periods of time. To accommodate this type of loading C26 and R34 are used to retard the firing of Q9 at low frequencies.

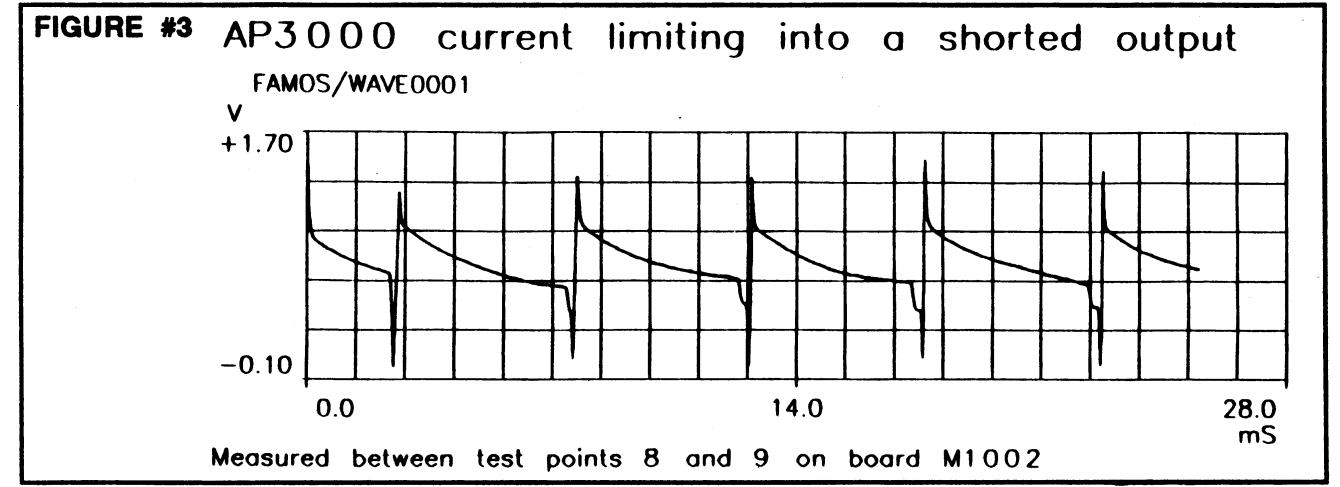

FREQUENCY: 100Hz Y SCALE: 1 VOLT = 10 AMPS

DC Protection

If a DC voltage greater than 8 volts appears on the output of the amplifier for more than 200 milliseconds then triac Q30 will turn on holding the output at ground potential. MBS4992 is a device that turns on at either + or - 8 volts DC.

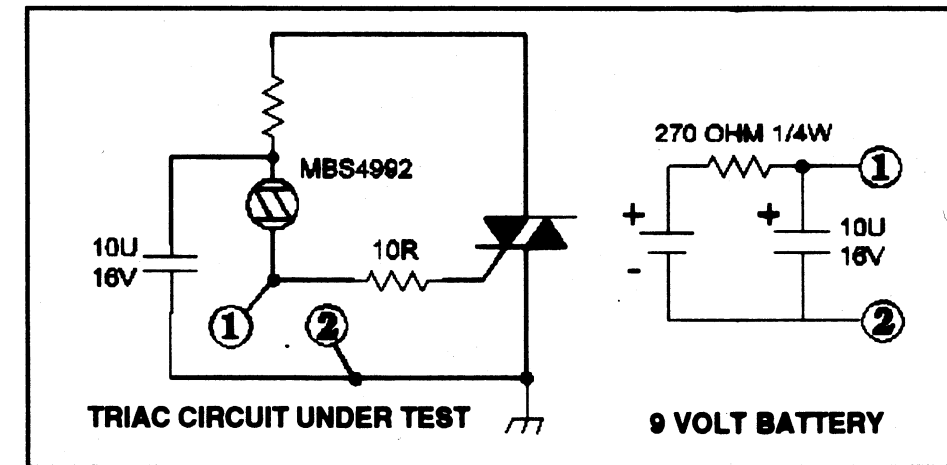

NOTE: Everytime you replace blown output transistors on a M1002 board test the DC protection triac with the following circuit.

Conditions of test:

- A. Pass a 100Hz 25v peak signal through the M1002 board under test with no load connected to the amplifier output.
- B. Connect points 1 and 2 as shown in the diagram. The amplifier should go into protect mode as the triac (if working) shorted the output of the amplifier to ground, and the amplifier goes into current limit.
- C. Disconnect the triac test circuit and allow the amplifier to complete it's protect cycle.
- D. Reverse connections 1 to 2 and 2 to 1 and test again. The same results as in B) should be observed if the triac is working.

Only test the triac for one protect cycle as prolonged testing will heat the triac to a high temperature.

EMS Circuit

The Energy Management System circuit only applies to North American line voltage products. A North American AC receptacle can provide 1850 watts before the wall breaker would trip, but how can an amplifier provide 2 x 1200 watts out when only 1850 watts is available out of the AC receptacle? A sinewave source connected to the amplifier driving the amplifier to full power output will cause the circuit breaker on the amplifier to trip. Music driving the amplifier to clipping can be equal an average power output between 12 and 30 percent of the amplifier's maximum capable power output. Under this condition less than 12 amperes of current is drawn from the AC line. Some synthesized music may go beyond the 12 to 30 percent level and make the amplifier draw more than 12 amperes from the AC line. If this occurs the coil on board M1013 heats up to the point where through the heating of thermistor RV5, Q32 sinks current through R109. On board M1011 Q11 starts conducting through the connection to R109. Q11 heats thermistors RV2 and RV4 attenuating the audio signal going to each amplifier channel, thus decreasing the current drawn from the AC line to the point where less than 12 amperes is being drawn.

Fan Circuit

Looking at the schematic to board M1013, here is a quick explanation of the fan control circuit. There is a thermistor on each M1002 board. When the amplifier is first turned on, Q33 is saturated sinking the current source through ZD10. As either negative temperature coefficient thermistor begins to heat up, more current flows through D38 or D39 decreasing the conductor of Q33 until the increasing VCE of Q33 is enough to turn on Q34 and Q35. Further heating of the thermistor causes an increasing of Q33's collector to emitter voltage. Q34 and Q35 are a common emitter stage with Q35 providing the drive current for the fan. To lower the dissipation of Q35, D42, D43, ZD12, ZD13 and R118 turn off Q35 when the full wave rectified voltage present of the collector of Q35 reaches approximately 50V by robbing current from the base of Q34. The maximum fan voltage is 20.5 VDC. ZD14 and R120, R121 and R122 provide a current limiting function. Figure #4 shows the current through these resistors when there is 12VDC across the fan.

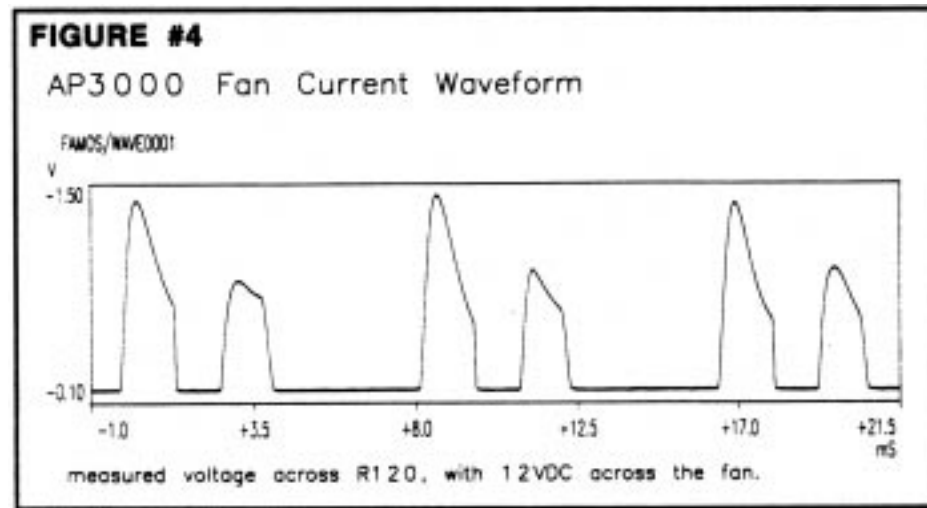

Thermal Shutdown Circuit

Test point 7 in the fan circuit is the measuring point for the shutdown voltage. As the temperature sensing thermistors that control the fan circuit heat up the voltage on test point 7 rises until at 85 degrees celcius on the M1002 heatsinks the voltage on test point 7 reaches 34.5 VDC and the amplifier must be shutdown to protect the output power transistors. ZD15 and D47 become forward biased and through the kill connection to board M1011, Q37 on M1011 turns on turning the relay off and muting the audio signal. After the amplifier cools down the kill voltage will decrease until Q37 turns off turning the relay back on enabling the amplifier.

Identifying Defective Boards in the AP-3000

STEP 1: VISUAL INSPECTION OF FRONT PANEL AND FAN

- A. Check to see whether the green power LED is lit. If not, the amplifier has a power supply (M1013 board), transformer, A.C. switch or line cord problem.
- B. If the red protect LED stays on or samples off and on, this usually indicates a problem with one or both of the M1002 current amplifier modules and possibly damage to the M1011 voltage amplifier board. Check for misaligned pin connections or see if the ribbon cables have been cut or pinched through their insulation.
- C. The fan running at full speed on power up usually indicates a problem with the fan circuitry on the M1013 board, but it can also be caused by M1011 circuit problems. Erratic fan behaviour can be caused by damaged thermistors located under the M1002 heatsinks.
- D. No output on either or both channels can be caused by intermittent push switches at the input.

STEP 2: VISUAL INSPECTION OF INTERNAL CHASSIS

- A. After removing the lid, look for any signs of smoke, charring or burnt components. If the M1002 boards have such damage there may be some damage to the M1011 voltage amp board in the form of blown ICs, or possibly open or shorted diodes, LED's, resistors, transistors or capacitors. Exploded electrolytic capacitors indicate you have major repairs to the M1002, M1011 and M1013 boards.

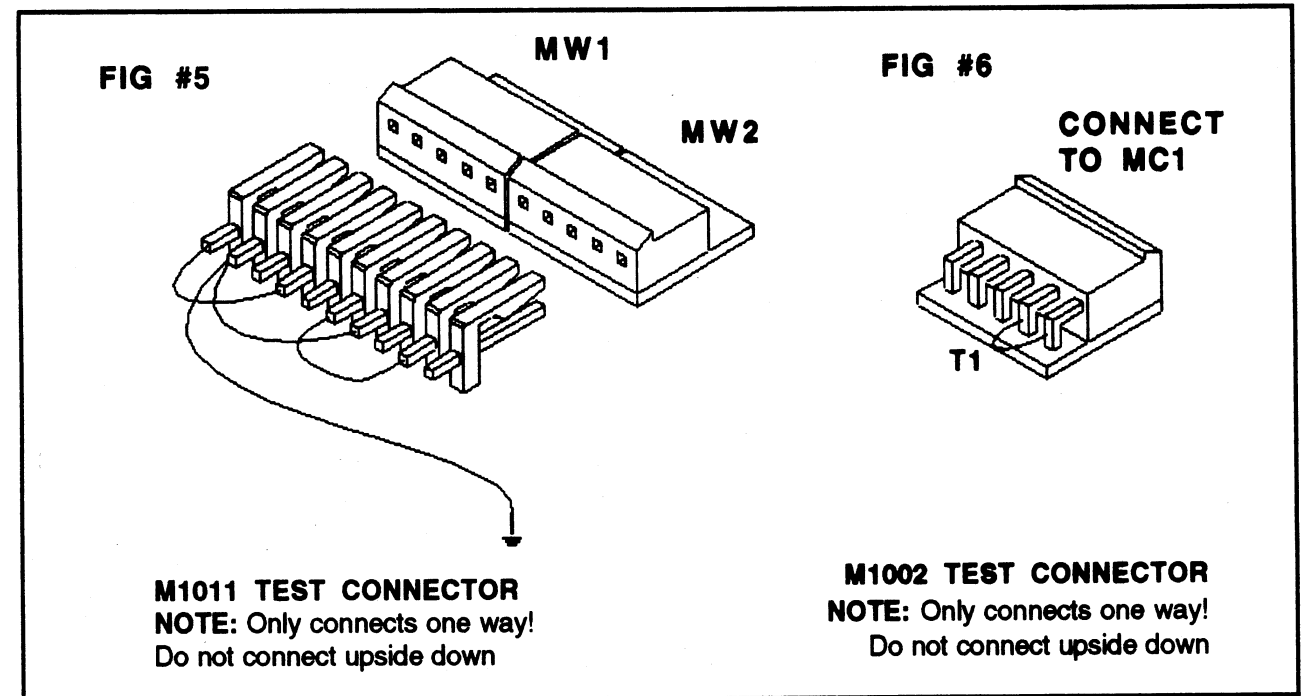

STEP 3: POWER UP PROCEDURE WITHOUT M1002 BOARDS

It is extremely important that you never power up an AP3000 with the interconnecting cables between the circuit boards not connected.

Time and possible further damage will be reduced if you test M1011 and M1002 boards separately. To do this you must use the M1011 and M1002 test connectors. These are shown in figures #5 and #6. These can be made if the Molex connector parts are available or order them from the Yorkville Service Parts Dept. With the test connectors connected to every board, slowly variac up the line AC voltage.

NOTE: It may be simpler to remove the power supply connections to M1002 boards not being troubleshooted to reduce the possibility of further damage. With the M1011 test connector connected, a sinewave can be passed through the board and be seen on test points 5 and 6. With the M1002 test connector installed, static DC measurements can be made. A slight DC offset may be present on the board's output as there will not be any DC correcting feedback.

STEP 4: DISMANTLING AND REASSEMBLY PRECAUTIONS

- A. When removing power supply wires or resoldering wires to eyelets on the M1011 board, double check that there are no solder bridges or icicles bridging traces or other eyelets. Failure to do so will result in the destruction of newly installed boards as well as other boards in the unit. Also make sure wire color codes are correctly oriented in their proper eyelets, and be careful that ribbon cables don't get pinched or cut under the M1011 board.
- B. When reinstalling M1002 boards, make sure the output wires, i.e. the red and yellow signal and black ground wires, are not reversed. If either or both channels are reversed, the amp will stay in protect mode with the red protect LED staying on or sampling on and off.

SPECIFICATIONS

POWER

- All values are in WATTS at 1KHz, except FTC 20Hz-20KHz.
- Measurements made with regulated 120 VAC sine wave at line cord.
- All values are rounded down to the nearest 25 watts

BURST AVERAGE

Measured as a 2 cycle burst at 1KHz, 8:1 duty. (Continuous measurements may require line currents >15 Amps).

ONE CHANNEL DRIVEN (WATTS).

LOAD	CONT. AVG.	BURST AVG.	PEAK INSTANT	FTC 20-20KHz
8ohms550	650	1500	475	
4ohms900	1250	3000		
2ohms1500	2250	6000	1200	

BOTH CHANNELS DRIVEN (WATTS).

LOAD	CONT. AVG.	BURST AVG.	PEAK INSTANT	FTC 20-20KHz
8ohms475	625	1500	425	
4ohms750	1200	3000	650	
2ohms1200	2175	6000	950	

BRIDGED (WATTS)

LOAD	CONT. AVG.	BURST AVG.	PEAK INSTANT	FTC 20-20KHz
16ohms925	1225	3000	850	
8ohms1500	2400	6000	1300	
4ohms2400	4350	12000	1900	

THD DISTORTION (measured at 1 dB below rated power BW = 80KHz)

LOAD	AT 1KHz	20Hz - 20KHz
8 ohms	<0.003 %	<0.04 %
4 ohms	<0.004 %	<0.05 %
2 ohms	<0.008 %	<0.06 %

CROSSTALK: -75 dB below full power at 1KHz
-60 dB below full power, 20Hz - 20KHz

INPUT IMPEDANCE: 20K ohms balanced, 10 Kohms unbalanced

INPUT SENSITIVITY: 1.4 VRMS sine wave = full power (36 dB gain).

FREQUENCY RESPONSE: Within 1dB, 20Hz to 20KHz (50Hz boost sw out)

HUM AND NOISE: -105 dB below max output RMS voltage, unweighted

DC OFFSET: less than 25 millivolts

PROTECTION: fully protected, DC, LOAD and THERMAL

COOLING: interleaved heatsink with DC servo controlled fan

SLEW RATE: Power amp: 30 V/usec, 60 V/usec in bridged mode

(rise time limited to 18 V/usec by input filter).

DAMPING FACTOR: >500, 20Hz - 400Hz, into 8 ohms

MAX OUTPUT CURRENT: 100 amperes for 10 milliseconds, 50 amperes continuous

TURN ON/OFF: < 15 milliwatts / seconds, 0.5 Wpk (1s on delay).

EFFICIENCY: Better than 75% at full power into 4 ohms

WEIGHT: 42 pounds 17.75 Kilograms

SIZE: 3.5" x 19" x 15.75" (front panel to binding posts)

POWER SUPPLY: Toroidal transformer and combination

power switch/circuit breaker

POWER COMSUMPTION: Will not exceed 13.5 Amps under actual conditions



Identifying Defective Boards in the AP-3000 & AP-3400

Please note: All boards used in the AP-3400 are designated with an 'A' suffix (e.g. M1002A) and use bright red solder mask

STEP 1: VISUAL INSPECTION OF FRONT PANEL AND FAN

a) Check to see whether the green power LED is lit. If not, the amplifier has a power supply (M1013 board), transformer, A.C. switch or line cord problem.

b) If the red protect LED stays on or samples off and on, this usually indicates a problem with one or both of the M1002 current amplifier modules and possibly damage to the M1012 voltage amplifier board.

Note: Any of the Molex cables from the M1011 circuit board to the M1012 input board as well as the M1002 current amplifiers can cause the protect LED to stay on or sample on and off. Check for misaligned pin connections or see if the ribbon cables have been cut or pinched through their insulation.

c) The fan running at full speed on power up usually indicates a problem with the fan circuitry on the M1013 board, but it can also be caused by M1011 circuit problems. Erratic fan behaviour can be caused by damaged thermistors located under the M1002 heat sinks.

d) No output on either or both channels can be caused by intermittent push switches at the input.

STEP 2: VISUAL INSPECTION OF INTERNAL CHASSIS

a) After removing the lid, look for any signs of smoke, charring or burnt components. If the M1002 boards have such damage, the M1011, M1012 and M1013 boards may also be damaged even if there is no similar charring on their components. At the least, there will be some damage to the M1011 voltage amp board in the form of blown ICs, or possibly open or shorted diodes, LEDs, resistors, transistors or capacitors. Exploded electrolytic capacitors indicate you have major repairs to the M1002, M1011 and M1013 boards.

STEP 3: POWER UP PROCEDURE WITHOUT M1002 BOARDS

It is *extremely important* that you never power up an AP-3000 or AP-3400 without following the procedure located on the M1011 schematic highlighted within the box drawn in dashed lines. Failure to do so will possibly result in damaging a good board. This procedure should only be done on a no load scoped output to insure the rest of the circuit boards are working before installing new or repaired M1011 modules. The output of a fully operational M1011 will give a 70V peak to peak sinusoidal (undistorted) wave form when a patch plug is attached at Pin #1. If the wave form is distorted or non-existent, or there is DC offset, do not attempt to connect any M1002 module to the M1011 or you will immediately destroy the new or repaired M1002 and will also cause more damage to the rest of the amplifier.

Note: M1002 power supply wires (red, yellow, white, blue and black) must be removed as well as the input Molex ribbon to the M1002 when attempting to power up an M1011.

STEP 4: DISMANTLING AND REASSEMBLY PRECAUTIONS

a) When removing power supply wires or resoldering wires to eyelets on the M1011 board, double check that there are no solder bridges or icicles bridging traces or other eyelets. Failure to do so will result in the destruction of newly installed boards as well as other boards in the unit. Also make sure wire color codes are correctly oriented in their proper eyelets, and be careful that ribbon cables don't get pinched or cut under the M1011 boards as this will result in shut down into the protect mode or even destruction of more boards.

b) When reinstalling M1002 boards, make sure the output wires, i.e. the red and yellow signal and black ground wires, are not reversed. If either channels or both are reversed, the amp will stay in protect mode with the red LED staying on or sampling on and off.

AP3000 Parts List 10/27/98

YS #	Description	Qty.	YS #	Description	Qty.	YS #	Description	Qty.
6405	RED 3MM LED 1V7 5MA BRIGHT PACE	3	3590	12.0 AMP SWITCH BREAKER WHITE	1	4824	1/4W 1K5 5% T&R RES	12
6410	GREEN 3MM LED 1V7 5MA BULK BRT CLR	3	3822	500NH COIL 18AWG 0R000 AIR CORE	1	4847	1/4W 2K2 5% T&R RES	2
6419	BRIDGE 35A 400V WIRE LEAD GI3504	2	3820	4UH COIL 14AWG ZOBEL HORIZONTAL	2	4804	1/4W 3K 5% T&R RES	6
6425	BAV21 200V 0A25 DIODE T&R	6	3464	WIRE TO BOARD CRIMP 18-24 AWGT/LEAD	2	6124	1/4W 3K 5%MINI T&R RES	4
6438	1N4004 400V 1A0 DIODE T&R	10	3465	WIRE TO BOARD CRIMP 16-18 AWG TIN	4	4827	1/4W 4K7 5% T&R RES	7
6825	1N4148 75V 0A45 DIODE T&R	71	3486	CLIP 250X032 22-18AWG DISCO-LOK	14	4982	1/4W 4K7 5%MINI T&R RES	4
6934	MR854 400V 3A0 DIODE FAST RECOV	24	3489	CLIP 250X032 18-22AWG DISCO/INSL	2	4862	1/4W 5K6 5% T&R RES	2
6439	1N5225B 3V0 0W5 ZENER 5% T&R	4	3490	CLIP 250X032 14-16AWG DISCO/INSL	2	4887	1/4W 7K5 5% T&R RES	13
6440	1N750ARL 4V7 0W5 ZENER 5% T&R	5	3682	250 MALE PCB TAB BULK ON CATRIGE	14	4663	1/2W 8K2 5% T&R RES	2
6459	1N4732A 4V7 1W0 ZENER 5% T&R	2	3447	DUAL BINDING POST TPP3	2	4990	1/4W 8K2 5%MINI T&R RES	2
6450	1N5242B 12V0 0W5 ZENER 5% T&R	4	3498	M203-02 PLAIN PC MNT JK SKT	2	4629	1/2W 10K 5% T&R RES	8
6822	1N4745A 16V0 1W0 ZENER 5% T&R	4	3660	FEMALE PC MOUNT XLR NTRX.NC3FPR-H-O	2	4800	1/4W 10K0 1% T&R RES	22
6824	1N5246B 16V0 0W5 ZENER 5% T&R	4	3630	FAN GUARD METAL 80MM CHROME	1	4829	1/4W 10K 5% T&R RES	2
6465	1N5250B 20V0 0W5 ZENER 5% T&R	6	3860	FAN 80MM X 80MM 40CFM 12VDC	1	4773	1/4W 12K1 1% T&R RES	1
6433	1N5257B 33V0 0W5 ZENER 5% T&R	2	3692	HEATSINK THERMALLOY 6079-PB	1	4901	1/4W 13K 5% T&R RES	4
5101	BC550C TO92 NPN TRANS. T&R	19	3893	AAVID HEATSINK 5811B	2	4830	1/4W 15K 5% T&R RES	7
5102	BC560C TO92 PNP TRANS. T&R	10	3894	AAVID 5972-B H/S W/TAB B.O.	4	4876	1/4W 16K 5% T&R RES	4
5103	MPSA06 TO92 NPN TRANS. T&R	4	3501	B52200F006 COMP WASH #4 SMALL	13	4771	1/4W 17K8 1% T&R RES	15
5107	2N5551 TO92 NPN TRANS. T&R	4	3750	VINYL CAP SC 0.500 BLACK 1/2"	1	6125	1/4W 18K 5%MINI T&R RES	2
5108	2N5401 TO92 PNP TRANS. T&R	3	3789	TERMINAL STRIP (BEAU INTERCONNECT)	1	4832	1/4W 22K 5% T&R RES	6
5113	MPSA42 TO92 NPN TRANS T&R	2	3806	RECTANGULAR WASHER FOR TRANS SUPPR	7	4840	1/4W 33K 5% T&R RES	2
5114	MPSA92 TO92 PNP TRANS T&R	2	8682	#4 TEFLON WASHER .125ID .281OD .031	1	4868	1/4W 36K 5% T&R RES	2
6854	2N6517 TO92 NPN TRANS.	2	3857	VELCRO HOOK	0.5	4834	1/4W 47K 5% T&R RES	11
5105	MPSA13 TO92 NPN DARLINGTON&R	1	8498	6-32 X 3/8 STEEL PEM STUD	4	4836	1/4W 68K 5% T&R RES	9
5106	MPSA63 TO92 PNP DARLINGTON&R	3	8499	6-32X1 STEEL PEM STUD	7	4772	1/4W 82K5 1% T&R RES	8
5123	NJM431L TO92 SHUNT REG T&R2V	4	3795	#8 GROUND LUG ZIERICK 505-169	3	4838	1/4W 100K 5% T&R RES	6
6456	BF872 TO202 PNP TRANS.	3	3810	4" NYLON CABLE TIE	9	4790	2.0W 150K 5%10MM BODY T&R RES	2
6457	BF871 TO202 NPN TRANS.	2	3827	SQUARE BUMPER BUTTON BLACK	11	4841	1/4W 220K 5% T&R RES	3
6873	MJE340 TO126 NPN TRANS	2	8444	CSA APPROVAL LABELS 1 15/16 X 3/4"	1	6126	1/4W 220K 5%MINI T&R RES	4
6874	MJE350 TO126 PNP TRANS.	2	3468	8? 3/16 SJT AC LINE CORD STRIP 17"	1	4843	1/4W 470K 5% T&R RES	4
6911	BDX54C TO220 PNP DARLINGTON	1	3821	HEYCO #1200 STRAIN RELIEF	1	6127	1/4W 470K 5%MINI T&R RES	2
6912	BDX53C TO220 NPN DARLINGTON	2	3521	SIDE ENTRY PCB CONN .156 8POS	1	4861	1/4W 820K 5% T&R RES	1
6752	MTP10N15L TO220 N CHAN MOSFET	2	3541	24 PIN BREAKAWAY 90 .156	0.333	4844	1/4W 1M 5% T&R RES	1
6781	MTW14P20 TO247 P CHAN MOSFET	2	3543	20 PIN BRKAWAY 90 LOCK .156	0.75	4888	1/4W 4M7 5% T&R RES	2
6924	MTW10N40E TO247 N CHAN MOSFET	2	3593	PCB CONN 90 5 CIR .156	3	3700	RELAY 2C 01AMP DC24 ???MA PC-S	1
6933	MTP23P06 TO220 P CHAN MOSFET	2	8701	4-40 KEPS NUT ZINC	16	3594	9.5" 5C-24AWG RIBBON HEAVY DUT.100"	3
6900	YS6900 (22) TO3 NPN TRANS.	16	8793	4-40 HEX NUT ZINC	2	3595	17" 8C-24AWG RIBBON HEAVY DUT.100"	1
6927	YS6927 (23) TO3 PNP TRANS.	16	8760	6-32 KEPS NUT TIN PLATED	64	8865	4-40 X 5/16 PAN PH MS SJ500	4
6840	MC33078P IC DUAL OP AMP	5	8800	6-32 KEPS NUT ZINC	28	8742	4-40 X 3/8 PAN PH TAPTITE JS500	4
6884	NE5532N IC DUAL OP AMP	1	8854	6-32 X 1/4 HEX NUT ZINC	6	8861	4-40 X 3/8 PAN PH MS SJ500	1
5190	MBS4992 TO92 8V5 DIAC T&R	2	8787	8-32 KEPS NUT ZINC	3	8741	4-40 X 1/2 PAN PH MS JS500	5
6444	MAC224-4 TO220 40A TRIAC 200V	2	8797	5/16-18 KEPS NUT SJ500	1	8871	4-40 X 5/8 PAN PH MS SJ500	8
6477	100K 5% 1/4W THERMISTOR T&R 0.2	8	3797	TO-247 THERMO CONDUCTIVE PAD	4	8799	#6 X 1/4 PAN PH TYPE B JS500	2
5200	.10P 200V 5%CAP T&R RAD CER.2"NPO	4	3815	TO3 PREGREASED MICA 56-03-2AP	32	8801	6-32 X 3/8 PAN PH TAPTITE SJ500	1
5404	.27P 100V 10%CAP T&R TUBULAR NPO	2	3846	TO220 MICA THERMAL CONDUCTOR 56359B	5	8829	6-32 X 3/8 FLAT PH TAPTITE BO#4 HEA	15
5408	.47P 100V 10%CAP T&R BEAD NPO	4	4597	22AWG STRAN TC WIR	19	8747	6-32 X 1/2 HEX ND MS ZINC	16
5410	100P 100V 10%CAP T&R BEAD NPO	4	4599	22AWG SOLID SC WIR T&R	79	8761	6-32 X 1/2 PAN PHIL MS ZINC CLEAR	64
5412	220P 100V 10%CAP T&R BEAD NPO	2	5299	24AWG SOLID SC WIR RAD	47	8806	6-32 X 1/2 PAN PH TAPTITE SJ500	2
5201	470P 100V 5%CAP T&R RAD CER.2"NPO	2	4745	5.0W 0R1 5% BLK RES	12	8802	8-32 X 3/8 PAN QUAD TPTTE SJ500 #6H	6
5416	470P 50V 10%CAP T&R BEAD NPO	6	4749	5.0W 0R15 5% BLK RES	4	8749	10-32 X 1/2 QDX PH TAPTITE JS500	6
5816	680P 100V 5%CAP T&R RAD CER.2"NPO	2	4677	1/2W 1R 5% T&R RES	4	8762	10-32 X1/2 TRUSS QUAD TAPTITE JS500	4
5422	.1N 50V 10%CAP T&R BEAD NPO	2	4877	1/4W 1R 5% T&R RES	2	8833	10-32 X 7/8 HEX CAP GRD 5 SJ500	4
5273	.1N5 200V 5%CAP T&R RAD CER.2"NPO	2	4973	1.0W 1R 5%FLAME PROOF T&R RES	6	8783	10-32 X 1 PAN QUAD TT JS500 BLACK	10
5274	.2N2 200V 5%CAP T&R RAD CER.2"NPO	4	4688	1/2W 2R2 5% T&R RES	3	8736	5/16-18X2-3/4 GRD 5 HEX BOLT JS500	1
6451	.4N7 250V 20%CAP AC Y ONLY RAD10MM	1	4911	1/4W 2R2 5% T&R RES	8	3433	0.080 SPACER OD.700 ID.330 PLASTIC	2
5272	.6N8 100V 5%CAP T&R RADIAL.2"FILM	2	4748	2.0W 3R9 5% BLK RES	2	8663	11/64 NYLON SPACER (MICRO PLASTIC)	66
5204	.10N 100V 10%CAP T&R RADIAL.2"FILM	2	4733	5.0W 5R6 5% BLK RES	2	3742	.250 SPACER ID.170 OD.31 ALUMINUM	4
5834	.10N 250V 20%CAP RAD POLYFILM BULK	2	4594	1/8W 10R0 2%FLAME PROOF T&R RES	3	8629	10-32 X 1/4 SPACER PHENOLIC	8
5210	.22N 100V 10%CAP T&R RADIAL.2"FILM	11	4610	1/4W 10R 2%FLAME PROOF T&R RES	6	3741	.5 SPACER ID-.171 OD-.25 #912-500	2
6435	.22N 275V 20%CAP AC X2 RAD BLK15MM	2	4875	1/4W 10R 5% T&R RES	2	3743	SNAP ON 0.5" SPACER RICHCO	3
5224	.47N 100V 10%CAP T&R RADIAL.2"FILM	2	4591	1/8W 22R1 1%FLAME PROOF T&R RES	2	8679	6-32 X 1/4 X 1.75 NYLON SPACER(HEX)	1
5226	.68N 100V 5%CAP T&R RADIAL.2"FILM	2	4607	1/8W 39R 2%FLAME PROOF T&R RES	8	8667	SHOULDER WASHER SWS-229 LENGTH 1/8	9
5228	100N 100V 5%CAP T&R RADIAL.2"FILM	4	4899	1/4W 39R 5% T&R RES	12	8818	3/4 OD X 5/16 ID X .08 THICK WASHER	1
5314	100N 50V 10%CAP T&R BEAD X7R	9	4817	1/4W 47R 5% T&R RES	2	3511	#6 FLAT WASHER NYLON	2
5229	150N 63V 10%CAP T&R RADIAL.2"FILM	2	4811	1/4W 68R 5% T&R RES	2	8485	#6 SPLIT WASHER ZINC	2
5882	220N 250V 10%CAP RAD POLYFILM BULK	6	4590	1/8W 100R0 1%FLAME PROOF T&R RES	4	8491	#10 SPLIT LOCK WASHER BO	10
5234	470N 63V 10%CAP T&R RADIAL.2"FILM	2	4659	1/2W 150R 5% T&R RES	2	8817	#10 FLAT WASHER BLACK OXIDE	8
5255	.1U 63V 20%CAP T&R RADIAL ELE.2"	2	4859	1/4W 150R 5% T&R RES	4	8850	#10 INT TOOTH LOCKWASHER BO	4
5257	.2U2 63V 20%CAP T&R RADIAL ELE.2"	4	4645	1/8W 220R0 1%FLAME PROOF T&R RES	4	8873	1.2500DX5/16ID FENDER WASHER BARE	1
5259	.4U7 63V 20%CAP T&R RADIAL ELE.2"	7	4857	1/4W 220R 5% T&R RES	4	3436	DPDT PUSH SW PCMT H BREAK B4 MAKE	2
5281	.10U 16V 20%CAP NONPOLAR T&R .2"	6	4770	1/4W 249R 1% T&R RES	12	3422	THERMO/BRKR.N/CLOSED OPEN@60C	1
5629	.10U 160V 20%CAP RADIAL ELECT BULK	4	4867	1/4W 270R 5% T&R RES	6	1300	AP-3000 T?RD	1
5260	.22U 50V 20%CAP T&R RADIAL ELE.2"	12	4855	1/4W 330R 5% T&R RES	1	M800P	BLACK ANODIZE AP-3000 H/SINK	8
5627	.47U 10V 20%CAP NONPOLAR RAD BULK	2	4821	1/4W 470R 5% T&R RES	10	M12.6X6	M1013X2 AP-3000 XFMR BD 20Z COPPER	0.5
5267	100U 25V 20%CAP T&R RADIAL ELE.2"	2	4822	1/4W 820R 5% T&R RES	2	M14.75X8	M1002X1 AP-3000 PWB BD 20Z COPPER	2
5630	330U 25V 20%CAP RADIAL ELECT BULK	6	4609	1/8W 1K 2%FLAME PROOF T&R RES	4	M15.7X11	M1012 X 4 AP-3000 I/P BOARD X 4	0.25
5621	470U 63V 20%CAP RADIAL ELECT BULK	5	4823	1/4W 1K 5% T&R RES	17	16X11.0	M1011 X 2 AP-3000 VOLTAGE AMP PCB	0.5
5900	10000U 63V 20%CAP RADIAL ELECT BULK	8	4654	1/2W 1K2 5% T&R RES	1			
4522	4K7 TRIM POT	2	4854	1/4W 1K2 5% T&R RES	2			
4400	.10K 25A-AUD/DETENT STYLE P15*16MM	2	4718	5.0W 1K5 5% BLK RES	4			

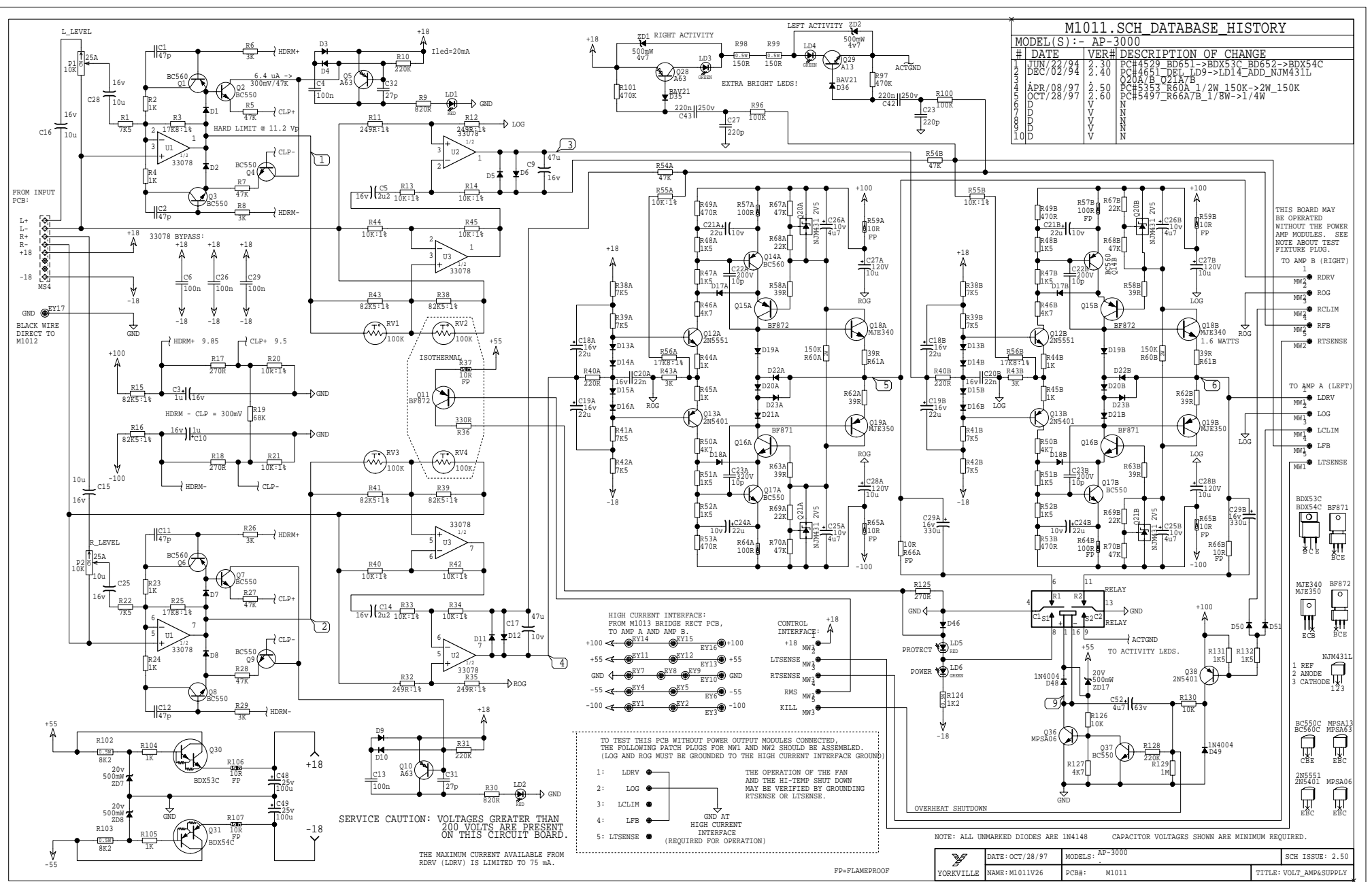
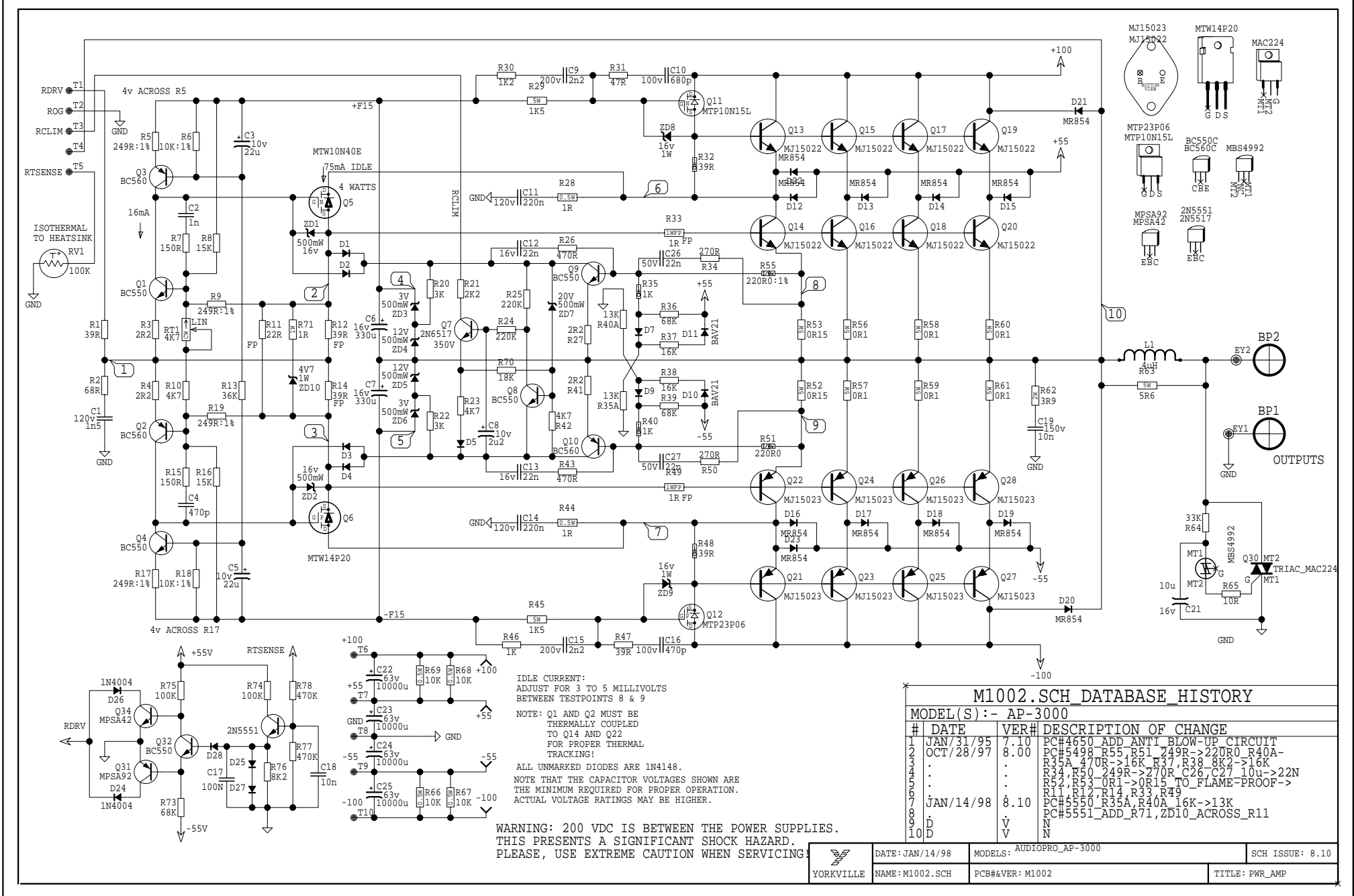

SERVICE CAUTION: VOLTAGES GREATER THAN 200 VOLTS ARE PRESENT ON THIS CIRCUIT BOARD.
THE MAXIMUM CURRENT AVAILABLE FROM RDRV (LDRV) IS LIMITED TO 75 mA.

THE M1011 MAY BE OPERATED WITHOUT THE POWER AMP MODULES.
TO TEST THE M1011 WITHOUT POWER OUTPUT MODULES CONNECTED, THE FOLLOWING PATCH PLUGS FOR M01 AND M02 SHOULD BE ASSEMBLED. (LOG AND ROO MUST BE GROUND TO THE HIGH CURRENT INTERFACE GROUND)
1: LDRV
2: LOG
3: LCLIM
4: LFB
5: LTSSENSE
(REQUIRED FOR OPERATION)

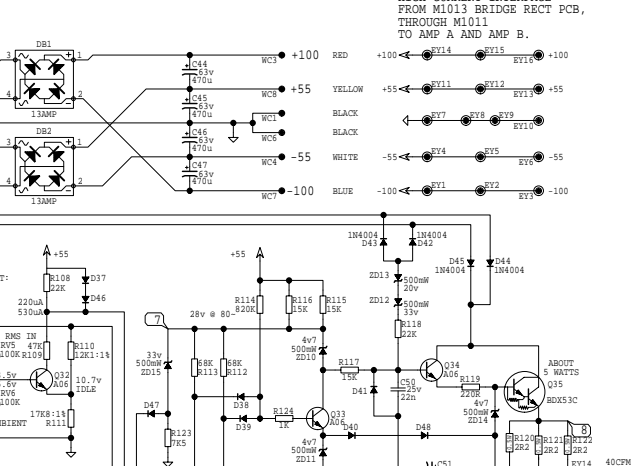
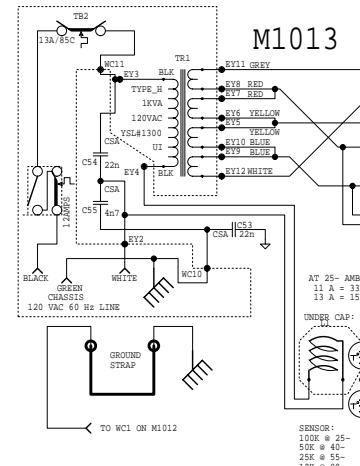
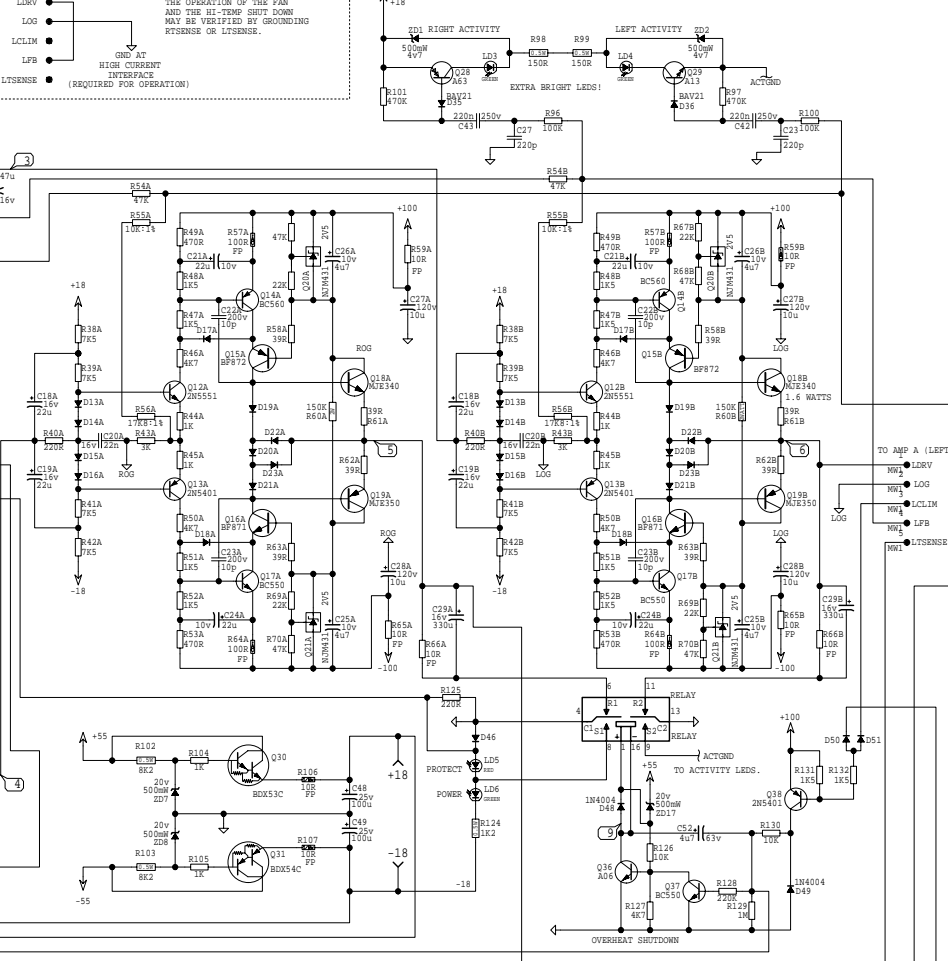
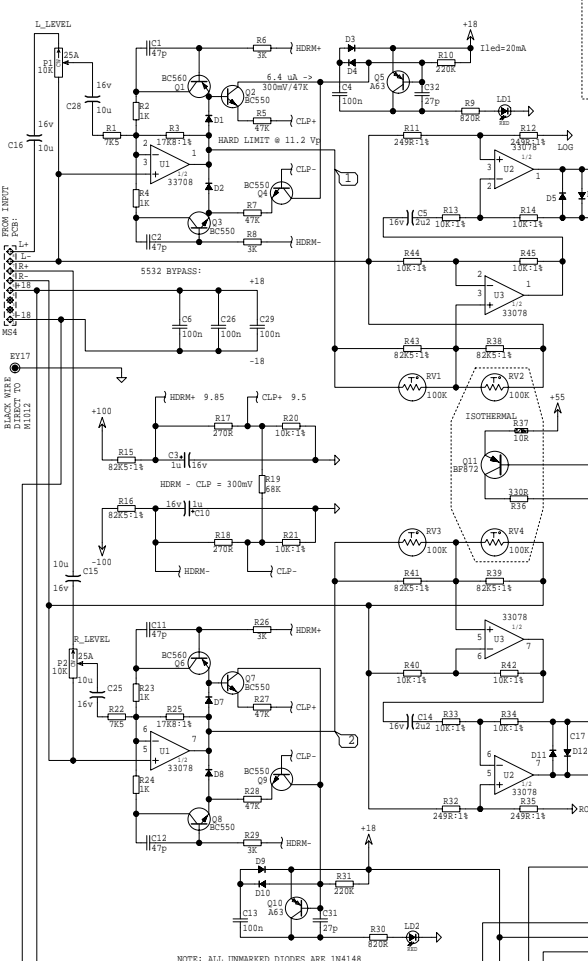
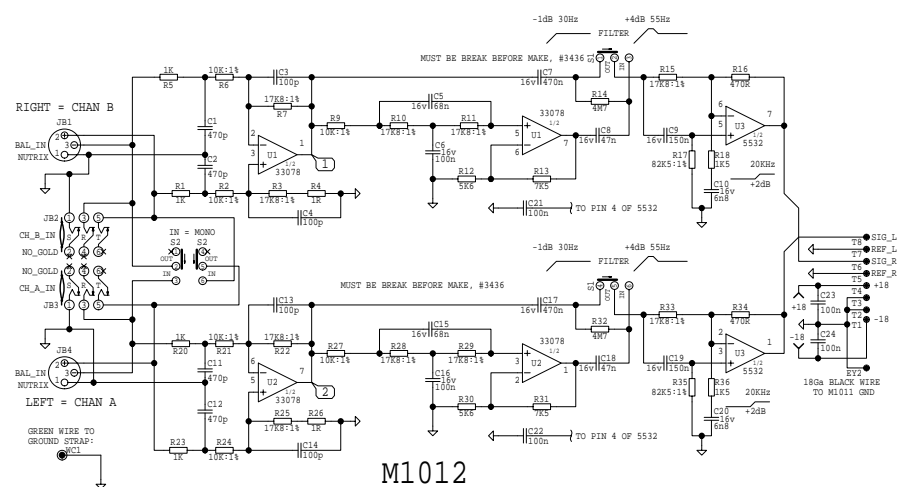

HIGH CURRENT INTERFACE: FROM M1013 BRIDGE RECT PCB, THROUGH M1011 TO AMP A AND AMP B.

NOTES:
NOTE: CAPACITOR VOLTAGE RATINGS SHOWN ARE MINIMUM REQUIRED. ACTUAL PARTS MAY HAVE HIGHER VOLTAGE RATINGS. ALL UNMARKED DIODES ARE 1N4148.
WARNING: 200 VDC IS BETWEEN THE POWER SUPPLIES. THIS PRESENTS A SIGNIFICANT SHOCK HAZARD. PLEASE, USE EXTREME CAUTION WHEN SERVICING!
IDLE CURRENT: ADJUST FOR 3 TO 5 MILLIVOLTS BETWEEN TESTPOINTS 8 & 9
Q1 AND Q2 OF M1002 MUST THERMALLY COUPLED TO Q14 AND Q22 FOR PROPER THERMAL TRACKING!

AP-3000.SCH DATABASE HISTORY

#	DATE	VER#	DESCRIPTION OF CHANGE
1	JUN/23/94	1.00	REVISED TO BUD52 TO BUD54C
2	JAN/11/95	1.10	REVISED M1011 LOG TEMP THRESHOLD TO 1.2V AND 47K & 22K
3	JAN/31/95	1.20	REVISED M1011 LOG TEMP THRESHOLD TO 1.2V AND 47K & 22K
4	SEP/12/97	1.30	REVISED M1011 LOG TEMP THRESHOLD TO 1.2V AND 47K & 22K
5	OCT/20/97	1.40	REVISED M1011 LOG TEMP THRESHOLD TO 1.2V AND 47K & 22K
6	OCT/20/97	1.50	REVISED M1011 LOG TEMP THRESHOLD TO 1.2V AND 47K & 22K
7	OCT/20/97	1.60	REVISED M1011 LOG TEMP THRESHOLD TO 1.2V AND 47K & 22K
8	OCT/20/97	1.70	REVISED M1011 LOG TEMP THRESHOLD TO 1.2V AND 47K & 22K

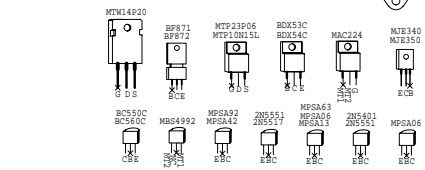

M1002 AP-3000

PRODUCTION NOTES

1 MOUNTING DETAILS FOR 5W

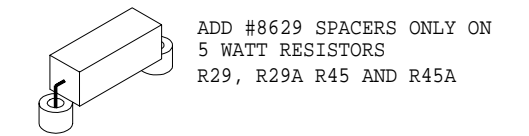

2 MOUNTING HARDWARE FOR Q5

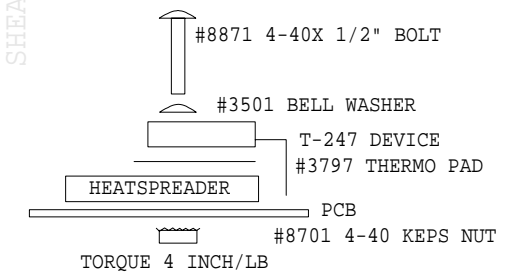

3 MOUNTING HARDWARE FOR Q11 AND Q12

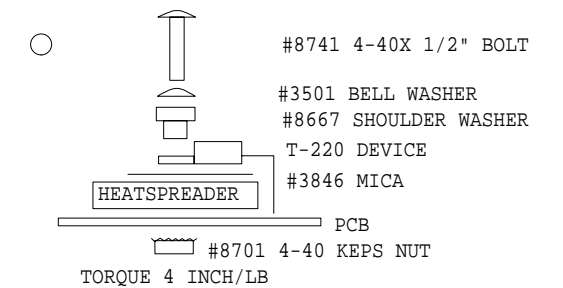

4 MOUNTING HARDWARE FOR TO3 OUTPUT

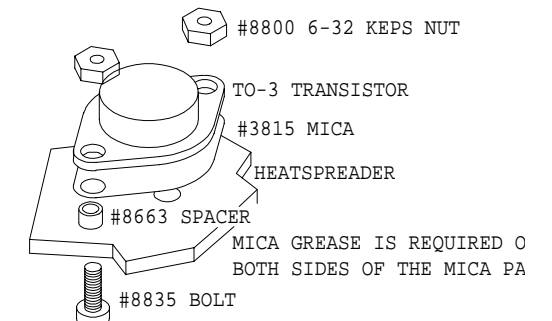

INITIAL TORQUE FOR TO-3'S IS 8 INCH/LB
FINAL TORQUE AFTER HEATSINK HAS COOLED FROM WAVE SOLDER IS 6 INCH/LB

5 USE #4973 SMALL BODY 1R 1W FOR R33,R49

7 THERMISTOR DETAIL
GENTLY PUSH THE THERMISTOR "RV1" WITH THE ERASER END OF A PENCIL SO THAT IT IS BELOW THE TOP SURFACE OF THE HEAT SPREADER

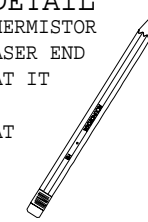

8 TAB WIRE COLOURS

- TAB 1 12"RED 16AWG
- TAB 2 10"YEL 16AWG
- TAB 3 8"BLK 16AWG
- TAB 4 7"WHT 16AWG
- TAB 5 6"BLU 16AWG
- TAB 6 OUTPUT +
- TAB 7 OUTPUT -

6 MOUNTING DETAILS FOR Q30 TRIAC

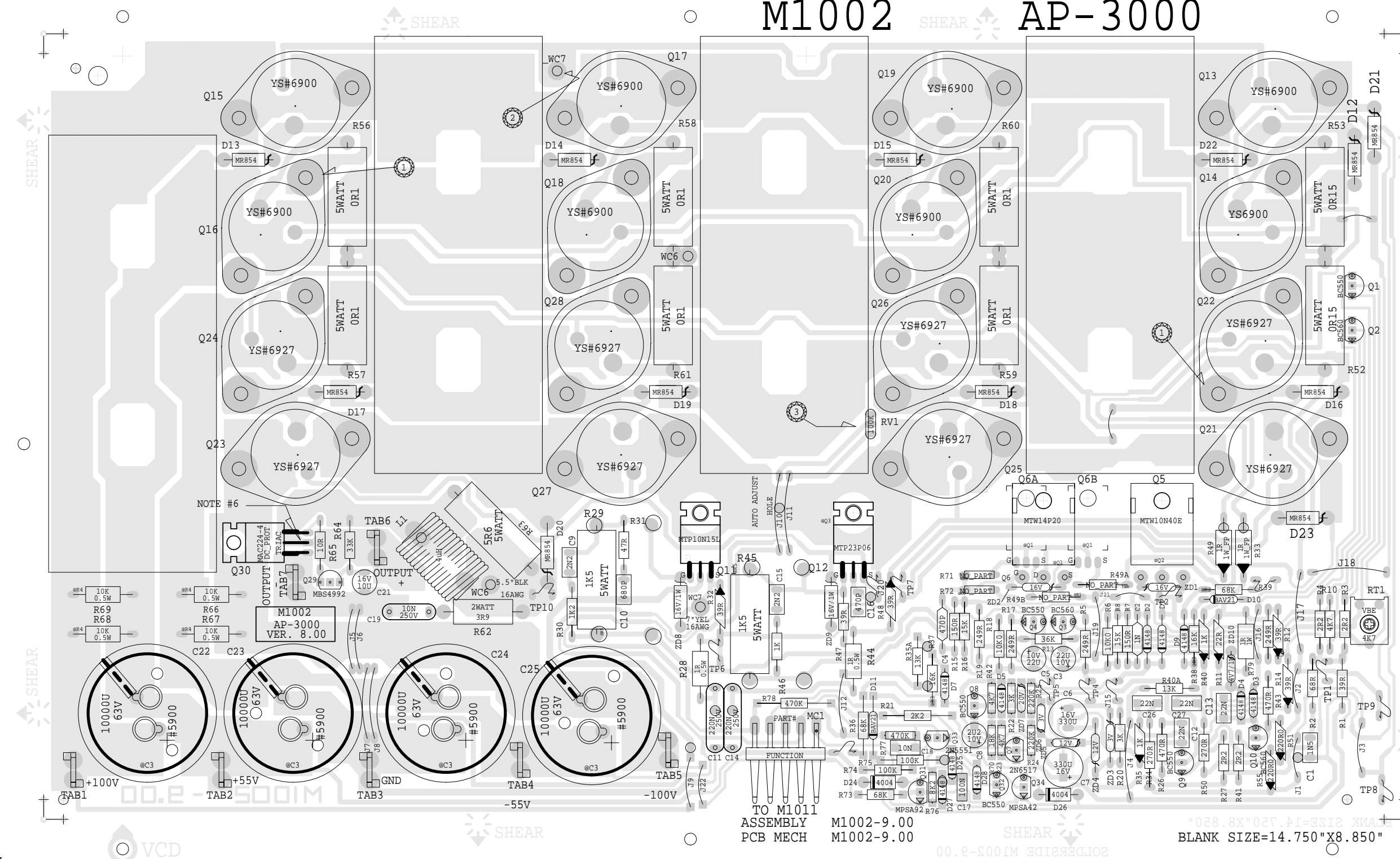
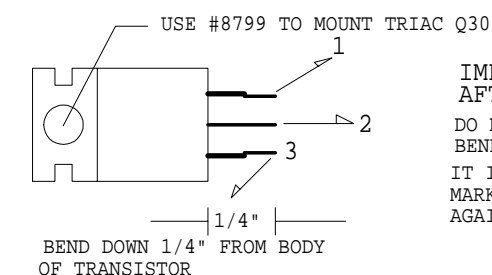

TO M1011 ASSEMBLY M1002-9.00
PCB MECH M1002-9.00

BLANK SIZE=14.750"X8.850"

M1002.PCB_DATABASE_HISTORY			
MODEL(S):- AP-3000			
#	DATE	VER#	DESCRIPTION OF CHANGE
1	AUG/25/94	6.00	PC#4645 REPLACE EYELETS WITH TABS
2			PC#4650 ADD DON'T BLOW ME UP CIRCUIT
3	FEB/28/95	6.10	TABS ADDED FOR SPKR OUTPUTS RTV HOLES MOVED TO ACCOMMODATE NEWER AND SMALLER FILTER CAPS
4	MAR/01/95	6.20	PC#4924 PAD SIZE FOR OUTPUT TRANSISTOR COLLECTORS MADE LARGER TO ACCOMMODATE ROBOT ASSEMBLY. CHANGES TO TRACE ONLY
5	OCT/19/95		ADDED ROUTING AT TP8-TP9
6			
7	JAN/97		
8	OCT/28/97	7.00	PC#5498 R55,R51 249R->220R0 R40A,R35A 470R->16K R37,R38 8K2->16K,R36,R39 36K->68K R34,R50 249R->270R C26,C27 10u->22N,R52,R53 OR1->OR15 R11,12,14,33,49 TO FLAMEPROOF. CIRCUIT CHANGES
9	DEC/17/97	8.10	PC#5550 R40A/R35A 16K->13K
10	JAN/28/98	9.00	PC#5550_ADD_R79,ZD10_ACROSS_R11
11			
12			
13			
14			
15			
16			
17			
18			
19			
20			

M1002A.PCB_DATABASE_HISTORY			
MODEL(S):- AP-3400			
#	DATE	VER#	DESCRIPTION OF CHANGE
1	AUG/25/94	6.00	PC#4645 REPLACE EYELETS WITH TABS
2			PC#4650 ADD DON'T BLOW ME UP CIRCUIT
3			PC#4531 PT#6923 FROM MTP2P45 TO MTP2P50E
4	FEB/28/95	6.10	TABS ADDED FOR SPKR OUTPUTS RTV HOLES MOVED TO ACCOMMODATE NEWER AND SMALLER FILTER CAPS
5	MAR/01/95	6.20	PC#4924 PAD SIZE FOR OUTPUT TRANSISTOR COLLECTORS MADE LARGER TO ACCOMMODATE
6	OCT/19/95		
7			
8			
9	DEC/09/97	7.00	PC#5546 R55,R51 249R->220R0 R40A,R35A 470R->20K R37,R38 10K->27K,R36,R39 27K->91K R34,R50 249R->270R C26,C27 10u->22N,R52,R53 OR1->OR15 R11,12,14,33,TO FLAMEPROOF. CIRCUIT CHANGES
10			
11			
12	DEC/08/97	8.00	PC#5546 R36,R39 1 END 78V->145V
13	JAN/28/98	9.00	PC#5550_ADD_R79,ZD10_ACROSS_R11
14			
15			
16			
17			
18			
19			
20			

GUIDE ETCH

VCD

M1011M

BLANK SIZE=16.000"X11.050"

BLANK SIZE=16.000"X11.050"

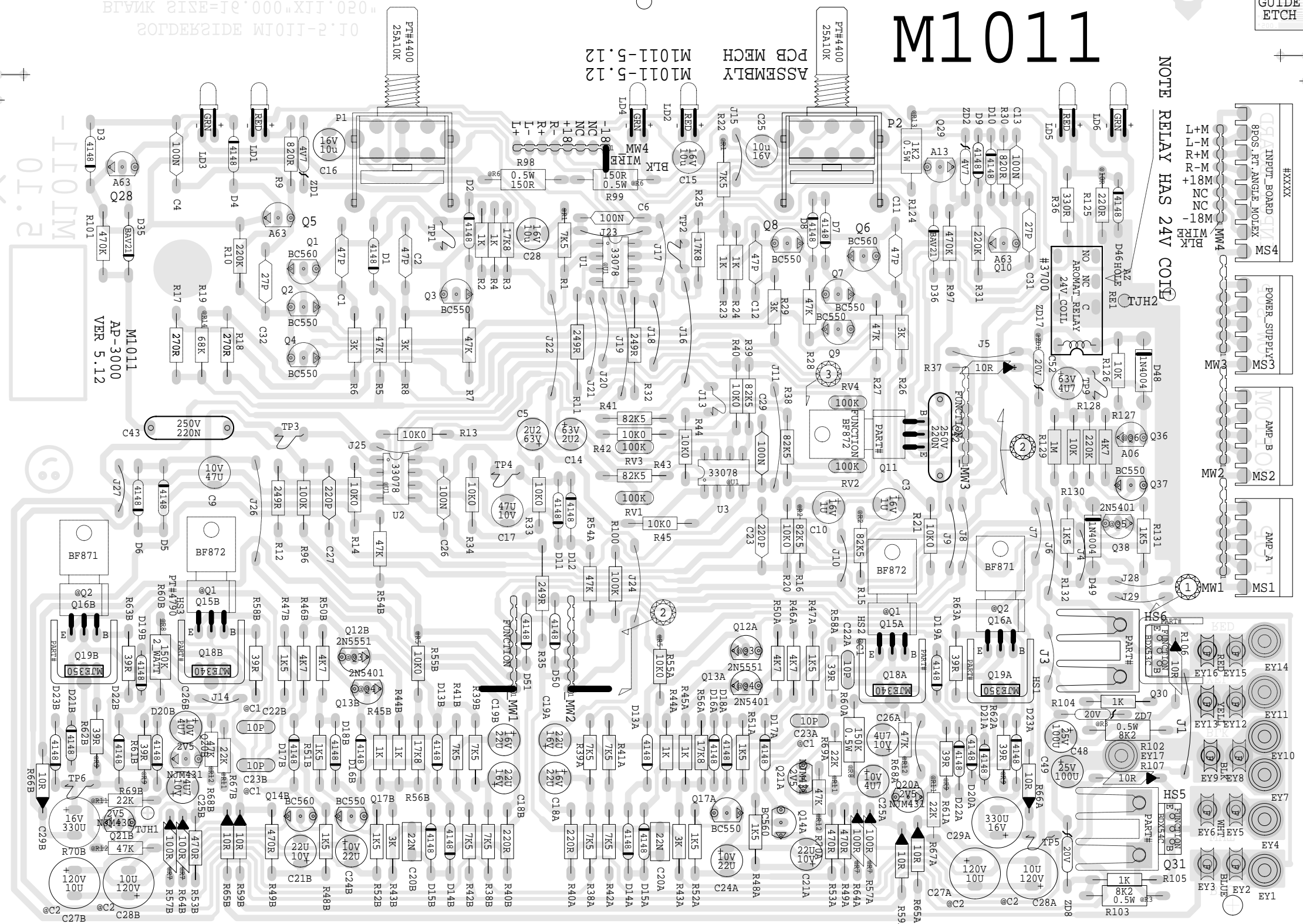

NOTE RELAY HAS 24V COIL

ASSEMBLY PCB MECH M1011-5.12

ASSEMBLY PCB MECH M1011-5.12

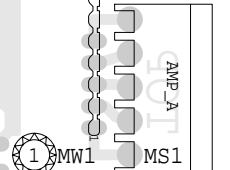
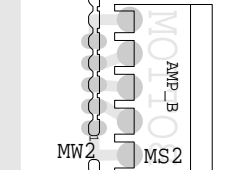
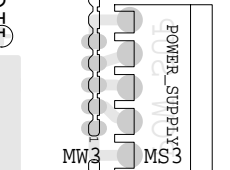
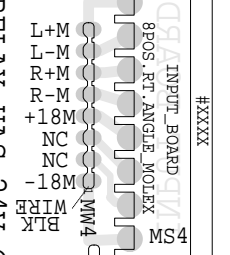

- +100 RED
- +55 YELL
- GND BLKL
- BLK
- WHT
- 55
- BLUE
- 100

SHEAR

ETCH GUIDE

SHEAR

M1011.PCB_DATABASE_HISTORY

#	DATE	VER#	DESCRIPTION OF CHANGE
1	JUN/22/94	4.53	PC#4529_BD651->BDX53C_BD652->BDX54C
2	NOV/29/94	5.00	PC4651_LED'S->NJM431+2_RESISTORS
3	FEB/15/95	5.10	Q14A/Q21A MOVED TO AID RAD INSERT
4	OCT/27/97	5.12	PC#5497_R66A/B_I/8WFP->1/4WFP
5	D	V	N
6	D	V	N
7	D	V	N
8	D	V	N
9	D	V	N
10	D	V	N
11	D	V	N

ETCH GUIDE

M1011A.PCB_DATABASE_HISTORY

#	DATE	VER#	DESCRIPTION OF CHANGE
1	AUG/06/93	4.51	PC#4443_R17,R18_470R->270R
2	.	.	R19_51K->43K
3	JAN/18/94	4.52	PC#4533_R19_43K->45K3
4	FEB/94	4.52	PC#4545_R1/R22_6K2->5K36
5	JUN/22/94	4.53	PC#4529_BD651->BDX53C_BD652->BDX54C
6	NOV/29/94	5.00	PC#4651_LED'S->NJM431+2_RESISTORS
7	FEB/15/95	5.10	Q14A/Q21A MOVED TO AID INSERTION
8	APR/08/97	5.11	PC#5353_R60A/B->2 WATT
9	OCT/27/97	5.12	PC#5497_R66A/B_I/8WFP->1/4WFP
10	D	V	N
11	D	V	N

PRODUCTION NOTES
 1 RV2,RV4 TO BE HAND
 INSERTED C3 1U 16V
 TO BE HAND INSERTED

SHEAR

ASSEMBLY M1012-2.10 BLANK SIZE=15.700"X10.000"
PCB MECH M1012-2.00

GREY_BUTTON
GREY_BUTTON

SWITCH/S
ARE #3436
BREAK
BEFORE
MAKE!!!!

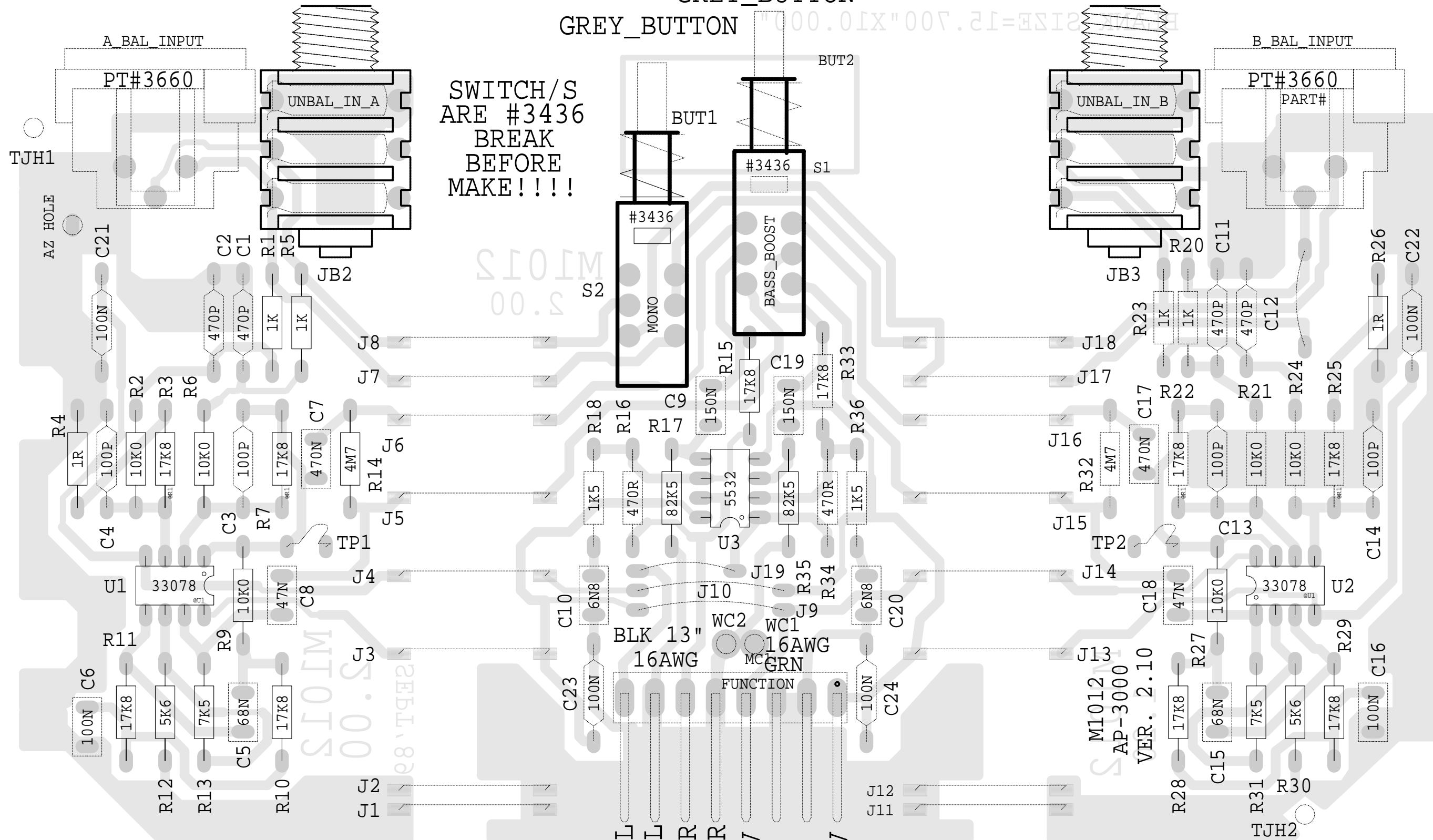

LINEWIDTH GAUGE

SIG_L
REF_L
SIG_R
REF_R
+18V
GND
GND
-18V

AP-3000
M1012

3

