



CL

CLUTCH

CLUTCH PEDAL ADJUSTMENT	CL- 2
PEDAL INSTALLATION HEIGHT	CL- 2
PEDAL FREE TRAVEL	CL- 2
CLUTCH RELEASE POINT	CL- 2
AIR BLEEDING	CL- 3
CLUTCH PEDAL	CL- 4
COMPONENTS	CL- 4
DISASSEMBLY	CL- 6
ASSEMBLY	CL- 6
CLUTCH MASTER CYLINDER	CL- 7
COMPONENTS	CL- 7
REMOVAL	CL- 7
ASSEMBLY	CL- 8
CLUTCH RELEASE CYLINDER	CL- 9
COMPONENTS	CL- 9
REMOVAL	CL- 9
ASSEMBLY	CL-10
CLUTCH HOSE	CL-11
COMPONENTS	CL-11
REPLACEMENT	CL-11
CLUTCH RELEASE MECHANISM	CL-12
COMPONENTS	CL-12
APPENDIX	CL-17
SSTs (Special Service Tools)	CL-17
TIGHTENING TORQUE	CL-17

JCL0001-00000

CLUTCH PEDAL ADJUSTMENT

PEDAL INSTALLATION HEIGHT

Loosen the lock nut. Adjust the pedal height by turning the adjusting bolt.

Tighten the lock nut.

Pedal Installation Height: 165 - 170 mm

Tightening Torque: 11.8 - 27.5 N·m

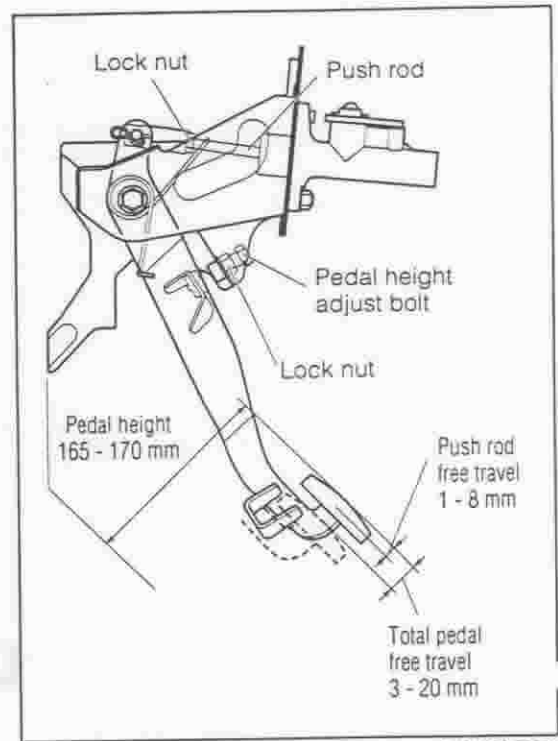

PEDAL FREE TRAVEL

1. Loosen the lock nut.
2. Adjust the pedal free travel by turning the push rod of the master cylinder.
3. Ensure that the pedal free travel is within the specified value. Tighten the lock nut.

Push Rod Free Travel: 1 - 8 mm

Total Pedal Free Travel: 3 - 20 mm

Tightening Torque: 14.7 - 21.6 N·m

NOTE:

- To adjust the clutch pedal free travel, it is necessary to remove the clutch pedal, together with the support bracket and master cylinder, from the vehicle.

CLUTCH RELEASE POINT

1. With the parking brake applied, set the engine to an idling state.
2. With the brake pedal depressed, place the shift lever in the 1st gear. Gradually release the clutch pedal. Measure the distance between the pedal and the floor at the point immediately before the clutch engagement.

Specified Value: At least 25 mm

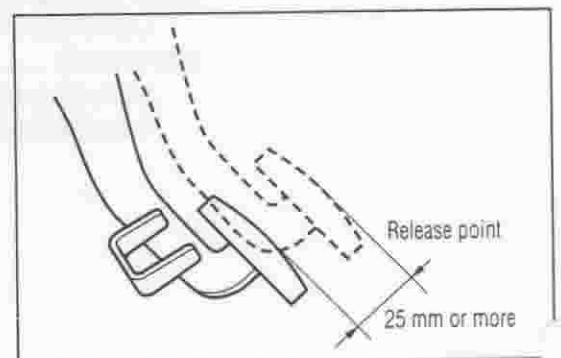

3. If the measured value is not within the specified value, conduct the following checks given below.
 - Inspect the pedal height.
 - Inspect the pedal free travel and push rod play.
 - Bleed the clutch line.
 - Inspect the clutch cover and disc.

JCL00005-00000

AIR BLEEDING

1. Fill and maintain the fluid level in the reservoir tank.

NOTE:

- If the fluid is spilled over the paint-finish surface of the vehicle or resin-made parts, immediately wipe off the fluid and flush it with fresh water.

Fluid: FMVSS 116 DOT3 or SAEJ1703

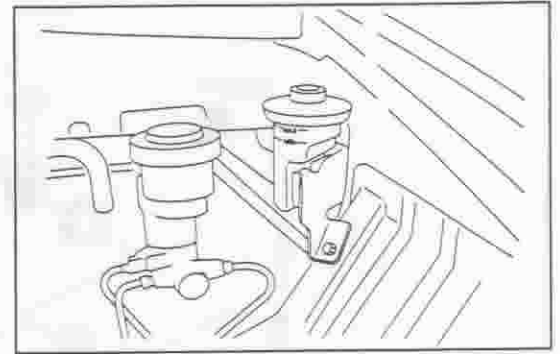

JCL00006-00002

2. Connect a suitable vinyl or rubber hose to the bleeder plug of the clutch release cylinder and insert the other end of the hose in a half-full container of the fluid.
3. Slowly depress the clutch pedal and hold it in a depressed state.

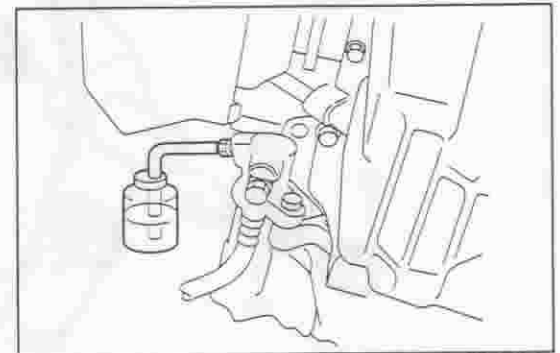

JCL00007-00003

4. While depressing the clutch pedal, slacken the bleeder plug to drain the fluid. Then, tighten the bleeder plug temporarily.
5. Repeat the steps "3" and "4" above, until bubbles are no longer observed in the fluid.
6. Tighten the bleeder plug securely
Tightening Torque: 8.82 - 12.74 N·m
7. Ensure that no fluid leakage on the clutch line when the clutch pedal is depressed fully.

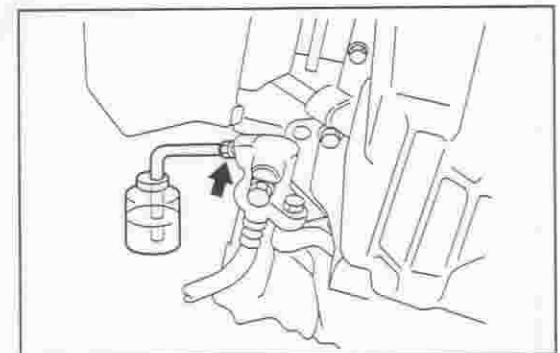

JCL00008-00004

CLUTCH PEDAL
COMPONENTS

RHD

 : Tightening torque
Unit : N·m

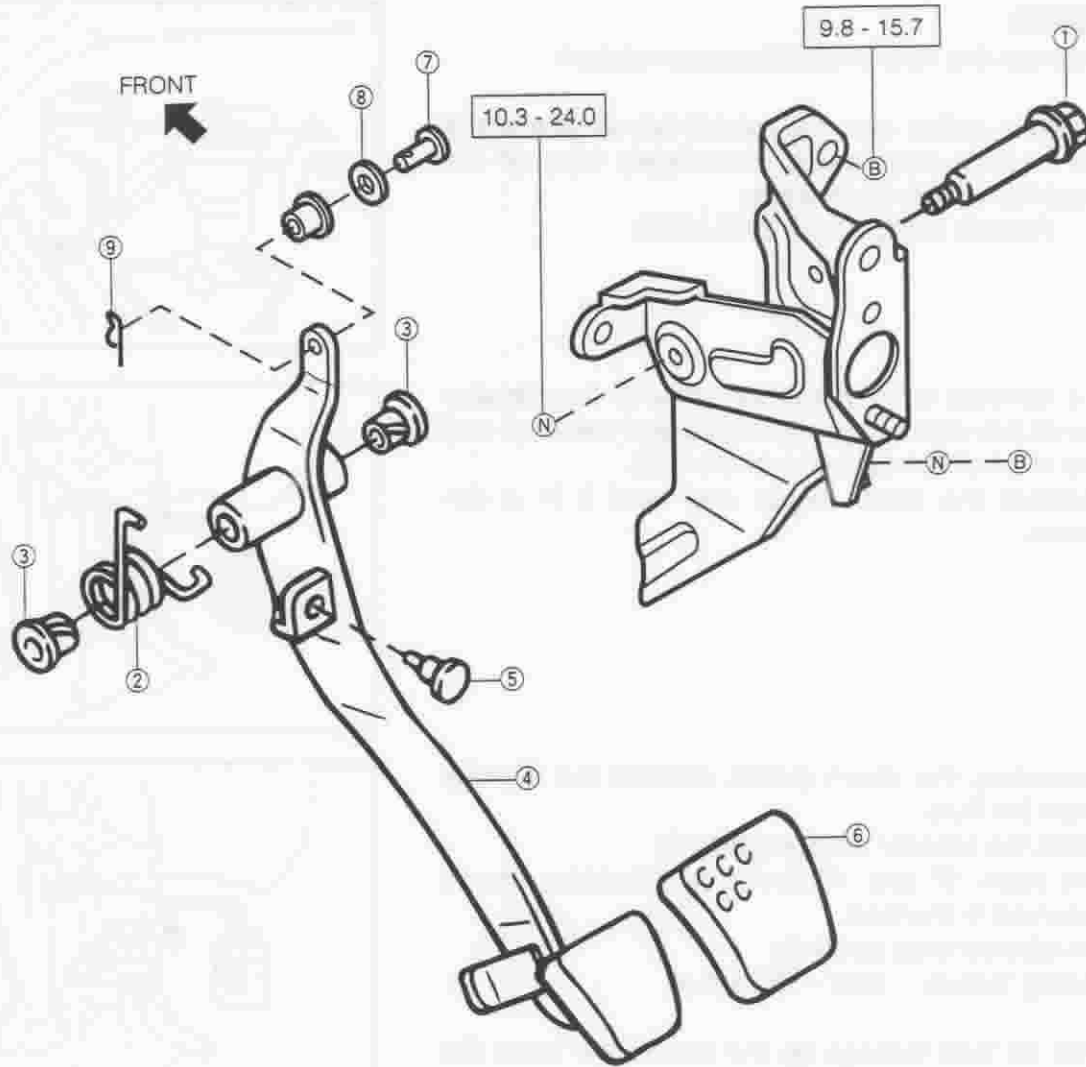

- ① Pedal shaft
- ② Spring
- ③ Bush
- ④ Clutch pedal subassembly
- ⑤ Cushion
- ⑥ Clutch pedal pad
- ⑦ Pin
- ⑧ Wave washer
- ⑨ Clip

LHD

 : Tightening torque
Unit : N·m

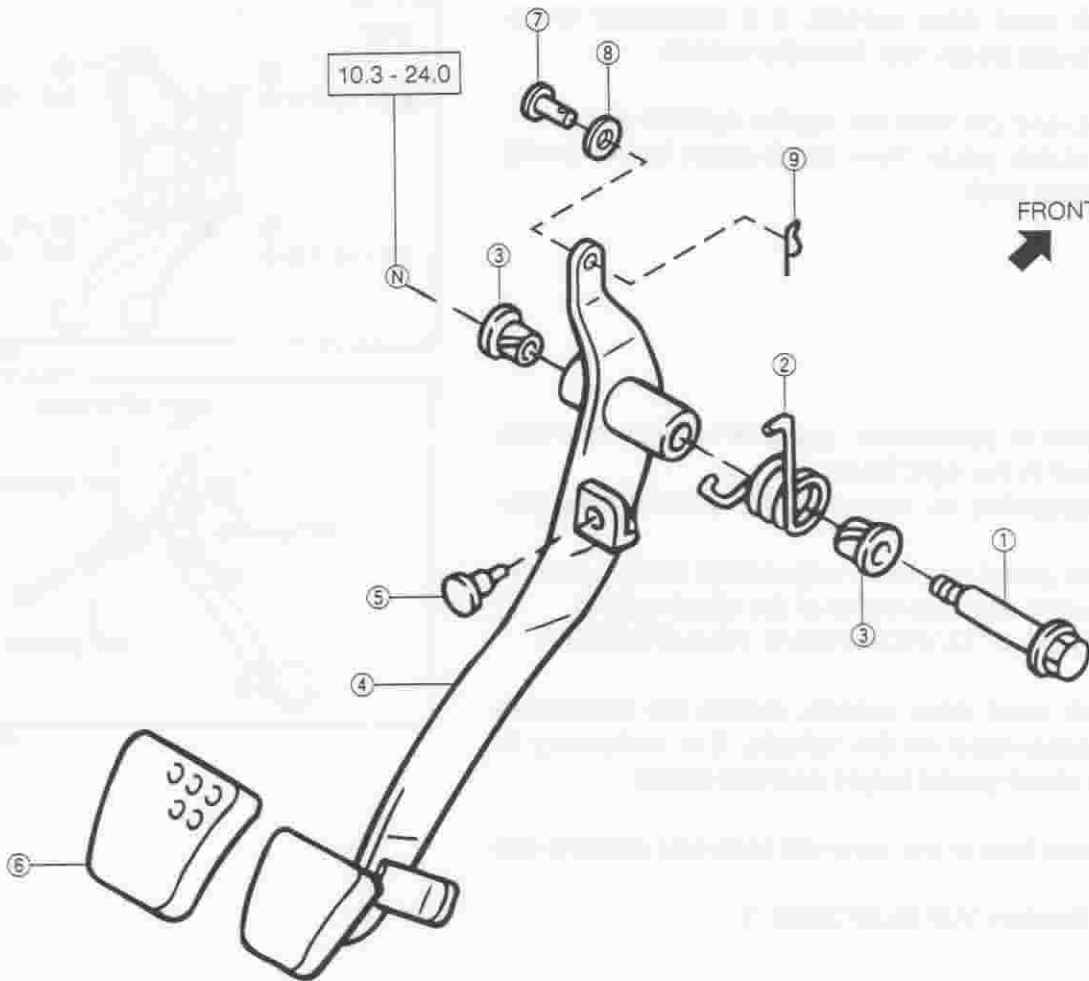

- ① Pedal shaft
- ② Spring
- ③ Bush
- ④ Clutch pedal subassembly
- ⑤ Cushion
- ⑥ Clutch pedal pad
- ⑦ Pin
- ⑧ Wave washer
- ⑨ Clip

JCL00000-00006

DISASSEMBLY

1. Drain the fluid from the clutch line.
2. On the left hand drive vehicle, remove the instrument panel and reinforcement from the vehicle. (Refer to the Section "BO".)
3. Disconnect the clutch tube and hose from the master cylinder.
4. Remove the clutch pedal, together with the bracket and master cylinder, from the vehicle by removing the bolts and nuts.

NOTE:

- On the left hand drive vehicle, it is necessary to remove the brake pedal, too, from the vehicle.

5. Detach the clip and pin from the master cylinder clevis.
6. Remove the clutch pedal from the bracket by removing the nut and pedal shaft.

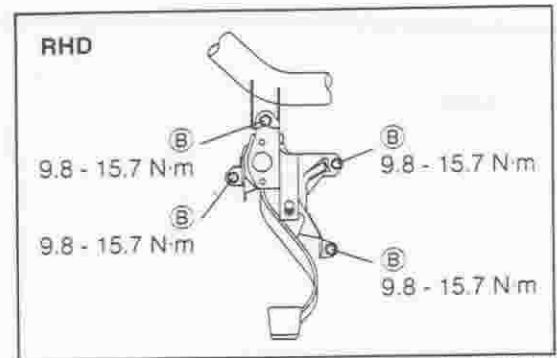

JCL00000-00039

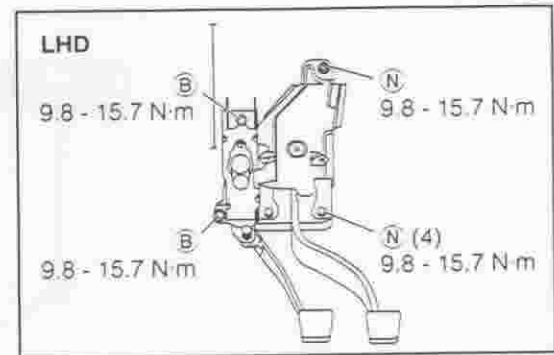

JCL00010-00040

ASSEMBLY

1. Before the pedal is assembled, apply MP grease to those points indicated in the right figure.
2. Perform the assembly by reversing the disassembly procedure.
3. After the clutch pedal has been assembled on the vehicle, confirm the height and free travel of the clutch pedal. (Refer to the Section "CLUTCH PEDAL ADJUSTMENT".)

NOTE:

- On the left hand drive vehicle, before the instrument panel is assembled on the vehicle, it is necessary to adjust the clutch pedal height and free travel.

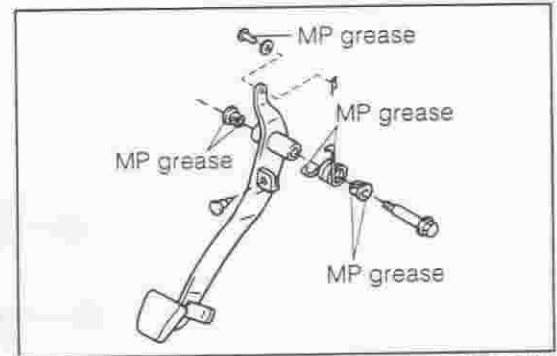

JCL00011-00007

4. Replenish brake fluid in the reservoir tank and perform the air bleeding. (Refer to the Section "AIR BLEEDING".)

CLUTCH MASTER CYLINDER COMPONENTS

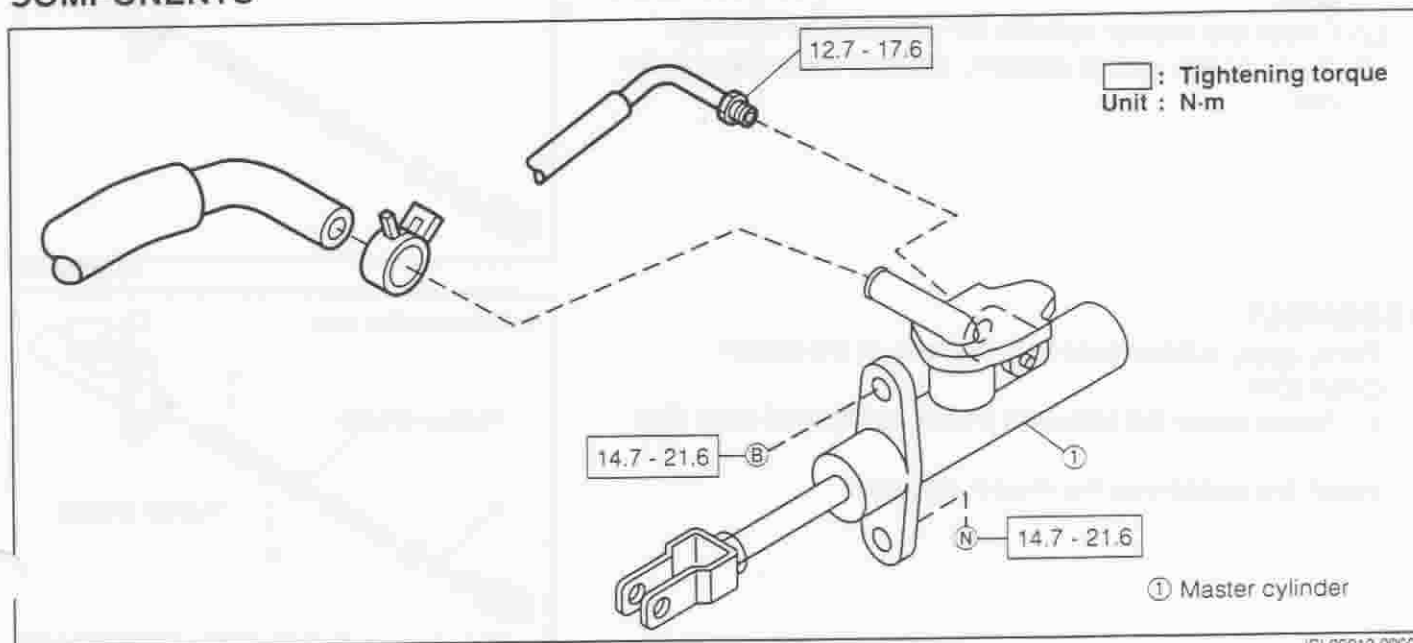

REMOVAL

NOTE:

- The master cylinder should be removed only after the master cylinder, together with the clutch pedal and bracket, has been removed from the vehicle.

- Detach the clip and pin from the master cylinder clevis.
- Remove the master cylinder from the bracket by removing the bolts and nuts.
- Clamp the master cylinder in a vice with aluminum sheet or the like interposed.

CAUTION:

- Never clamp the cylinder section in a vice. Failure to observe this caution can distort the cylinder section.

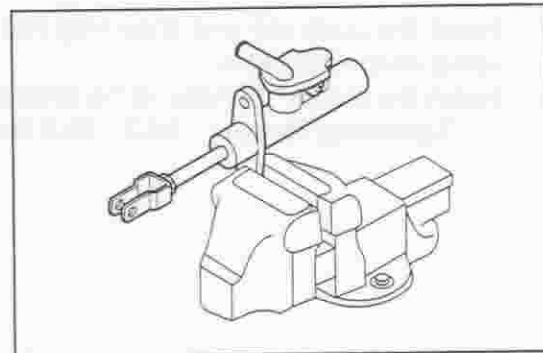

- Using snap ring pliers, detach the snap ring from the master cylinder.
- Remove the piston from the master cylinder.

CAUTION:

- Never score the cylinder bore during the removal of the piston.
- Remove the piston in a straight direction.
- Never reuse the removed piston.

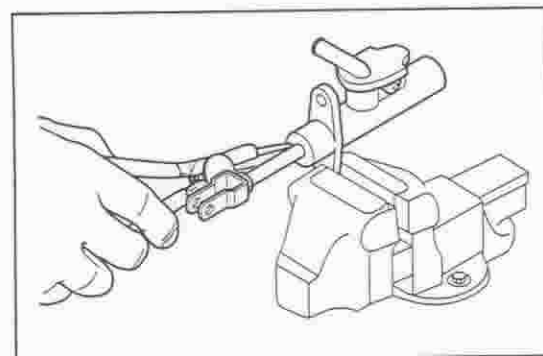

6. Inspect the master cylinder.
 - (1) Check to see if any score is present at the cylinder bore.
 - (2) Check the master cylinder for distortion or damage.
 - (3) If any score, etc. is present, replace the master cylinder.

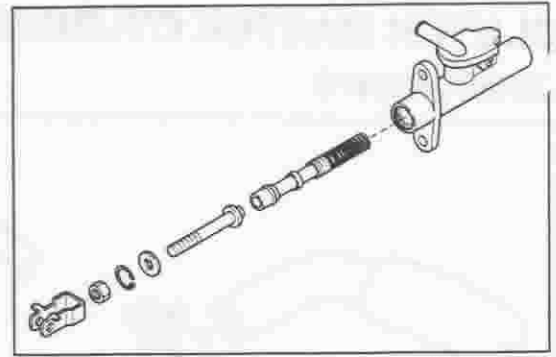

JCL00015-00010

ASSEMBLY

1. Thinly apply rubber grease to the cup of the piston.

CAUTION:

 - Never reuse the removed piston, spring and snap ring.
2. Install the piston into the master cylinder.

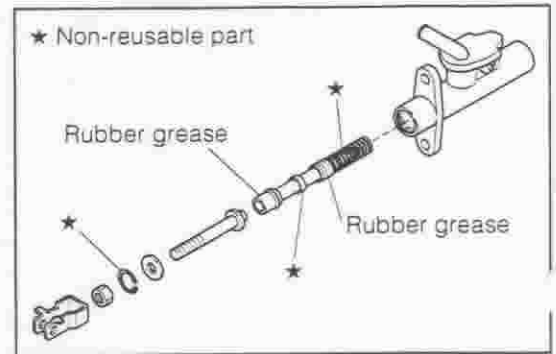

JCL00016-00011

3. Install the push rod and snap ring into the master cylinder, using snap ring pliers.
4. Install the master cylinder to the bracket.

Tightening Torque: 14.7 - 21.6 N·m

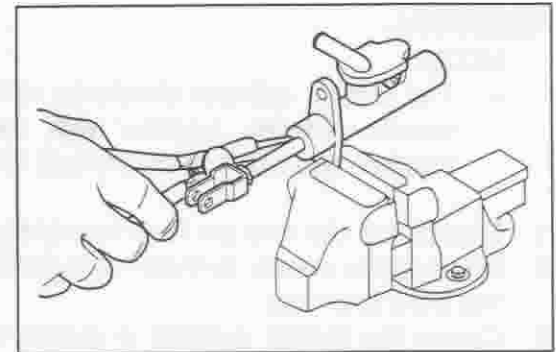

JCL00017-00012

5. Connect the clutch pedal and master cylinder clevis by using the pin and clip.
6. Install the bracket together with the clutch pedal and the master cylinder into the body.
7. Perform the air bleeding.
8. Check the pedal installation height and the pedal free travel.

JCL00018-00000



CLUTCH RELEASE CYLINDER COMPONENTS

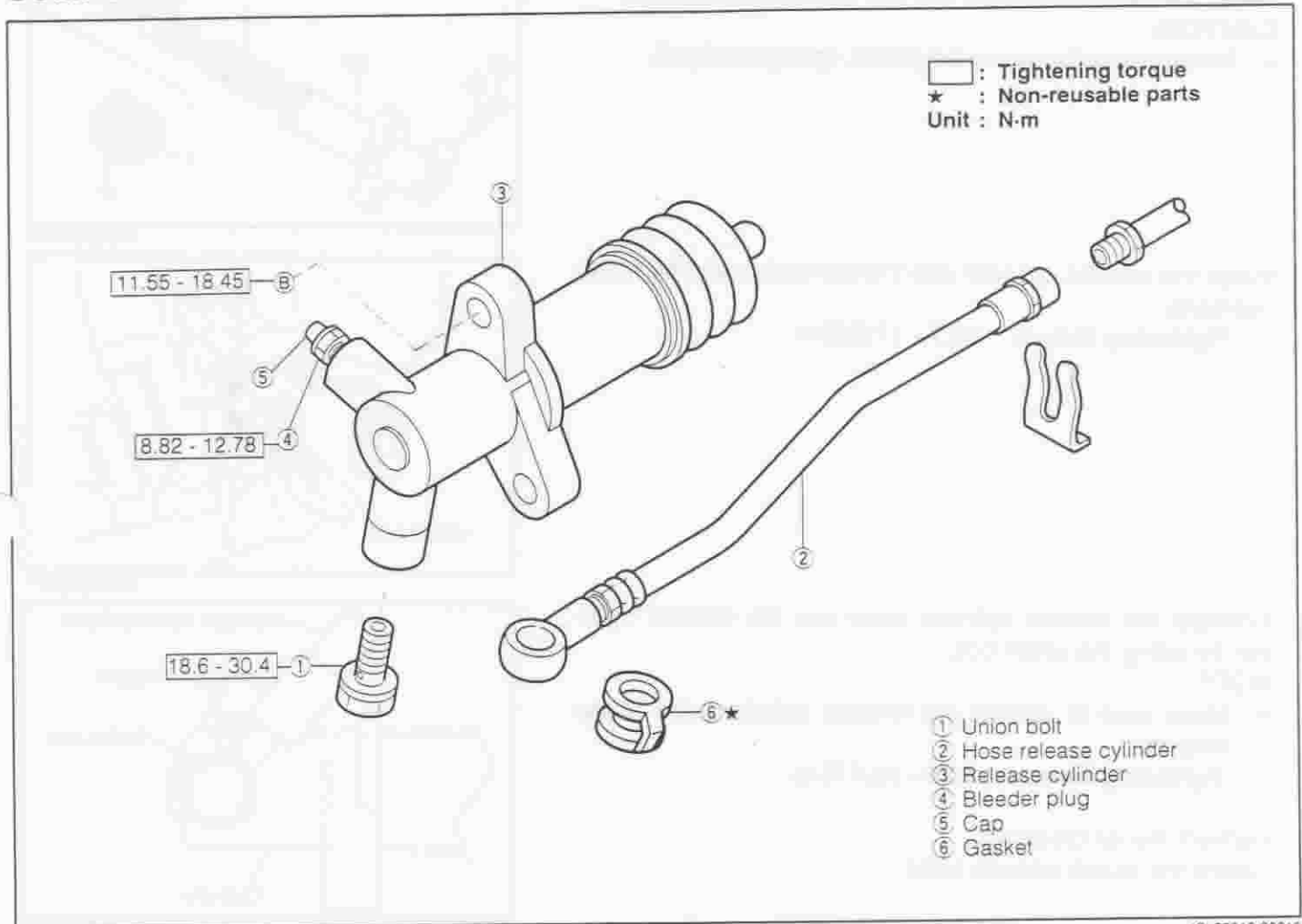

JCL00019-00013

REMOVAL

1. Drain the fluid from the clutch line.
2. Remove the hose from the release cylinder by removing the union bolt.
3. Remove the release cylinder from the transaxle case by removing the two bolts.
4. Remove the piston from the release cylinder.
5. Check to see if any score is present at the release cylinder bore.
6. Check the release cylinder for distortion or damage.

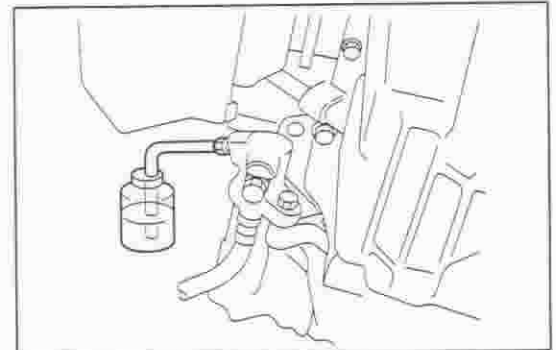

JCL00020-00014

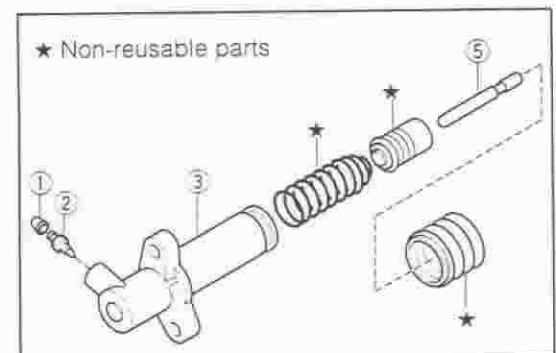

JCL00021-00015

ASSEMBLY

1. Thinly apply rubber grease to the cups.
2. Install the piston and push rod into the release cylinder.

CAUTION:

- Never reuse the removed piston, spring and boot.

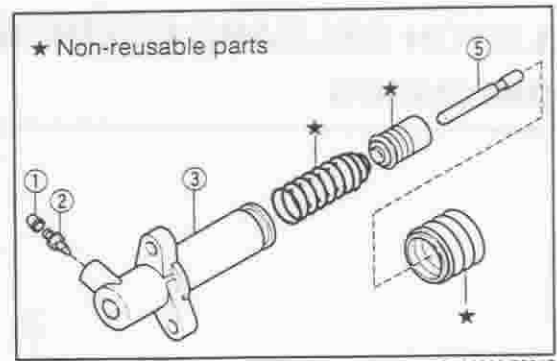

3. Install the release cylinder into the transaxle case by using two bolts.

Tightening Torque: 12.7 - 17.6 N·m

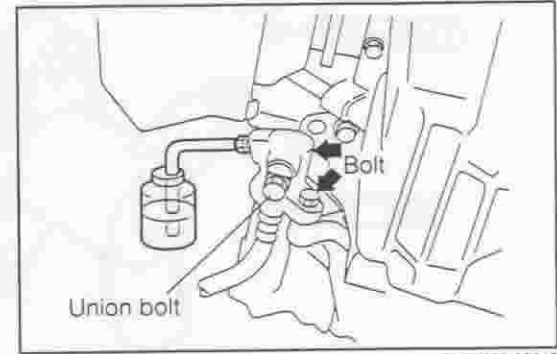

4. Connect the release cylinder hose into the release cylinder by using the union bolt.

NOTE:

- Make sure to contact the release cylinder hose to the stopper.

Tightening Torque: 18.6 - 30.4 N·m

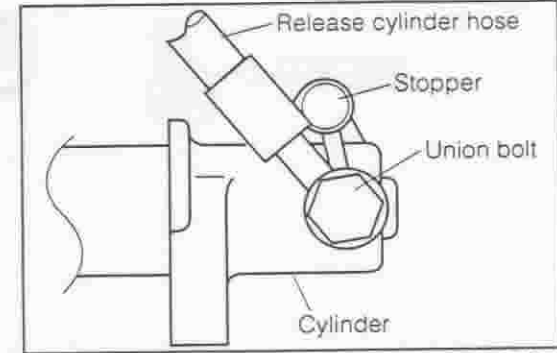

5. Perform the air bleeding.
6. Check the clutch release point.

CLUTCH HOSE COMPONENTS

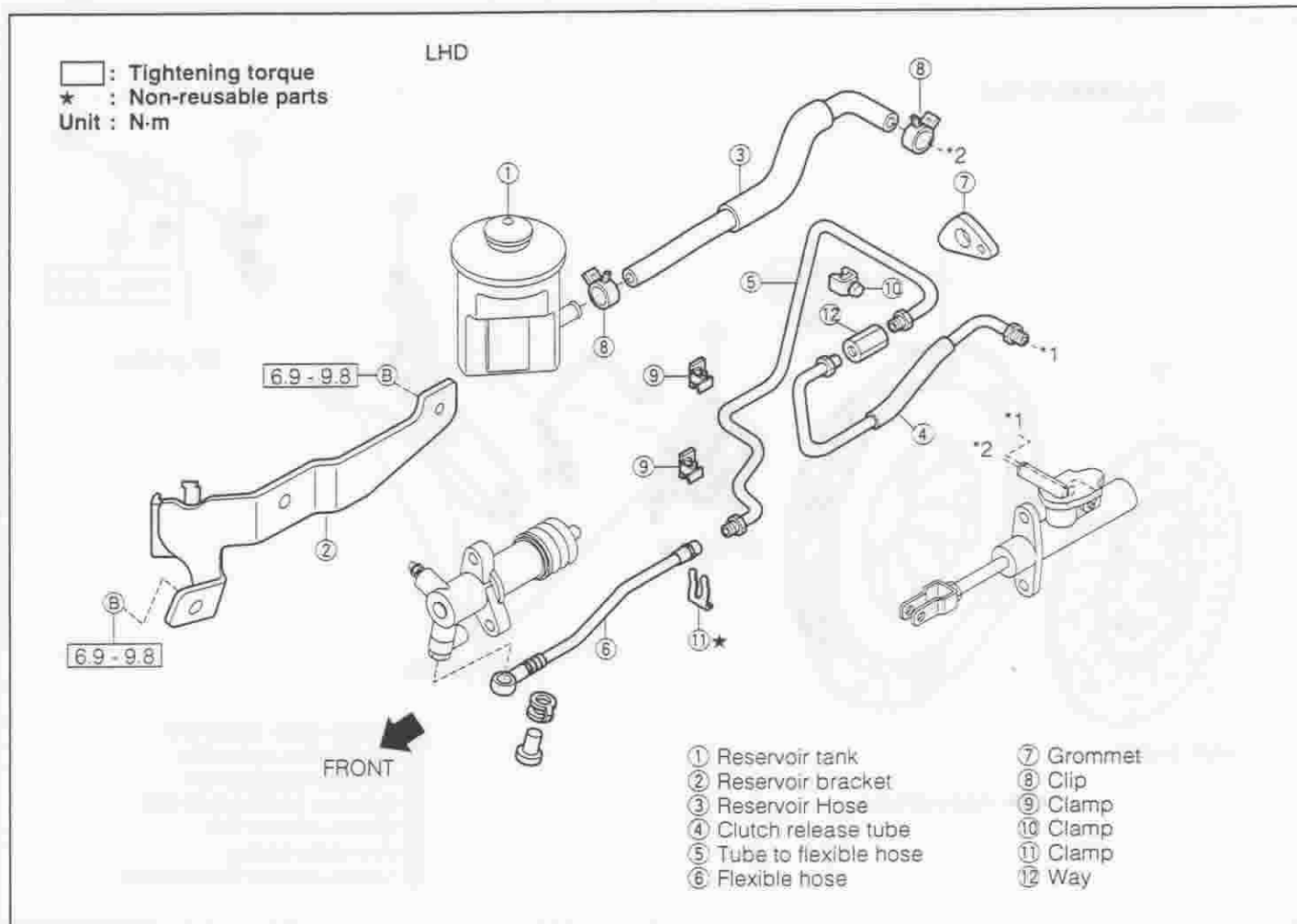

JCL00024-00018

REPLACEMENT

1. Drain the fluid from the clutch line.
2. Disconnect the flare nut of the tube, using a flare nut wrench.
3. Disconnect the hose by removing the clip, E-ring and union bolt.

CAUTION:

- Never reuse the used E-ring.

4. Inspect the tube and hose and replace it with a new one if any damage exists.
5. Connect the hose by installing the clip and a new E-ring.
6. Connect the flare nut of the tube, using a flare nut wrench.

Tightening Torque: 12.7 - 17.6 N·m

7. Perform the air bleeding.
8. Check the clutch release point.

JCL00025-00000

CLUTCH RELEASE MECHANISM COMPONENTS

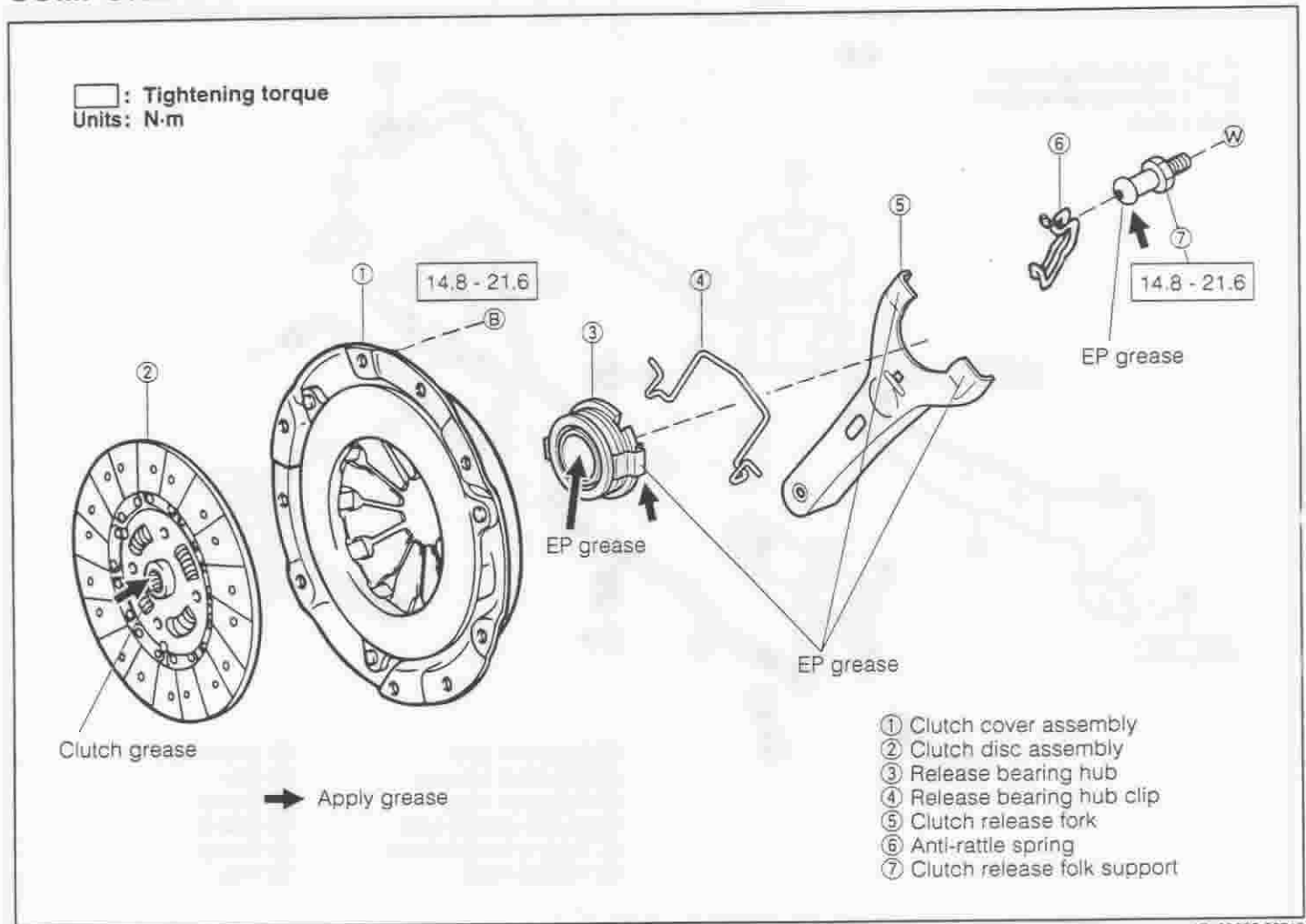

JCL00026-00019

OPERATION PRIOR TO REMOVAL

1. Remove the transmission assembly from the vehicle.
(Refer to the MT section.)

JCL00027-00000

MAIN POINTS OF REMOVAL

1. Remove the clutch cover assembly and clutch disc assembly, while preventing the ring gear from turning by means of the following SST.
SST: 09210-87701-000

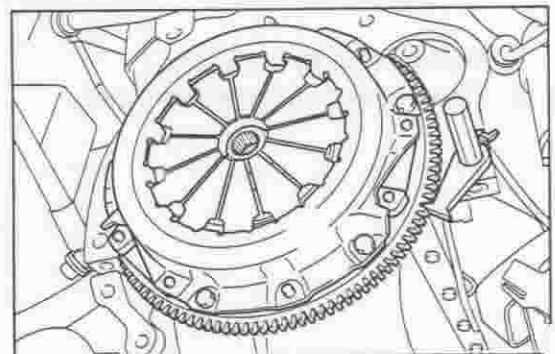

JCL00028-00020

CHECK**Clutch cover and diaphragm spring**

Inspect the following parts. Replace any parts which exhibit defects.

1. Check the clutch pressure plate and the clutch disc contracting surface of the flywheel for evidence of wear or burns.
2. Check the diaphragm spring lever for wear, corrosion or damage.

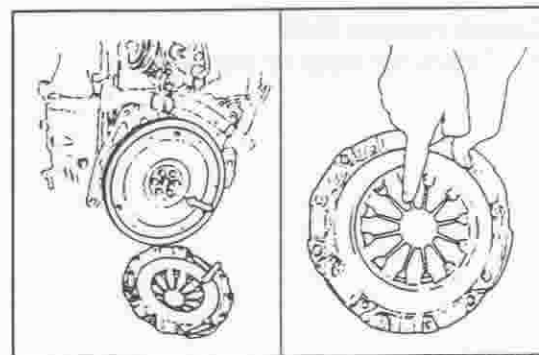

JCL00029-00021

Clutch disc

1. Check the clutch disc for wear.

Rivet Depth

Limit: 0.3 mm

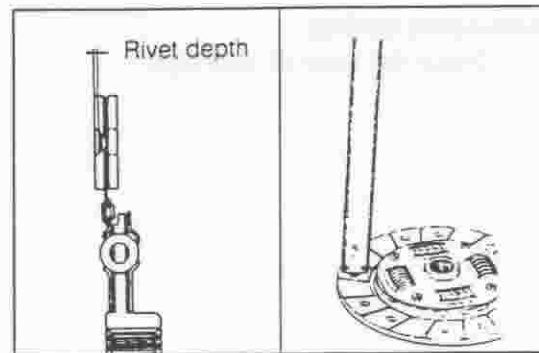

JCL00030-00022

2. Check the clutch disc for runout.

Runout

Limit: (Longitudinal Runout): 1.0 mm

(Lateral Runout): 0.7 mm

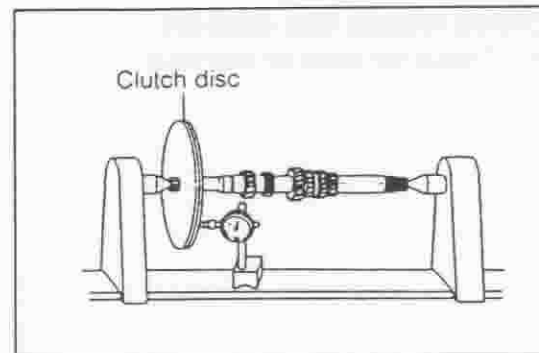

JCL00031-00023

Release bearing

1. Checking of release bearing for smooth turning. Turn the release bearing while applying a force to the bearing by your hand in the thrust direction. Ensure that you feel no abnormal stiffness or binding.
2. Check the release bearing hub for damage or wear. Also, check to see if any damage or wear is present at the clip contact surface and the housing sliding section.

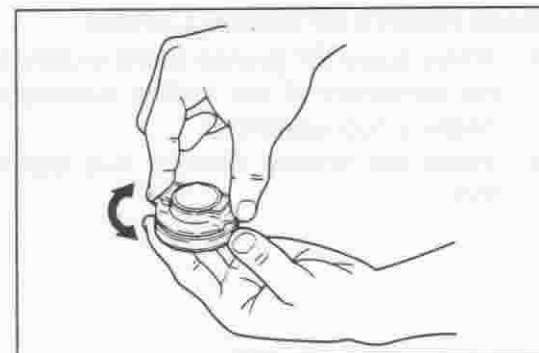

JCL00032-00024

Release bearing hub clip

1. Check for wear or damage.

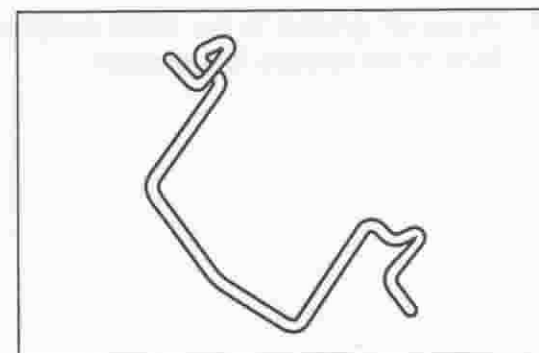

JCL00033-00025

Clutch release fork

1. Check for wear or damage.

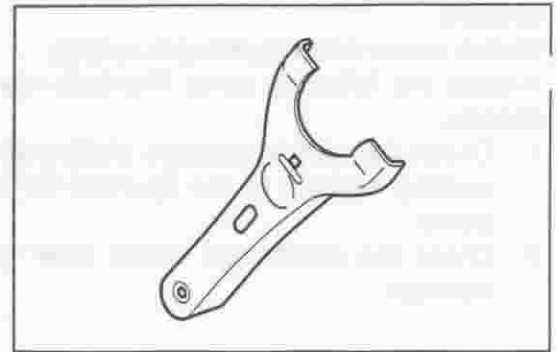

JCL00034-00026

Anti-rattle spring

1. Check for wear or damage.

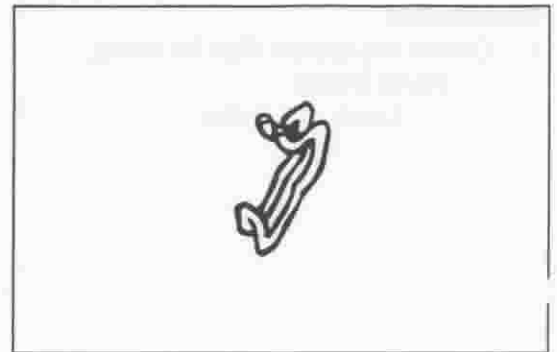

JCL00035-00027

Clutch release fork support

1. Check for wear or damage.

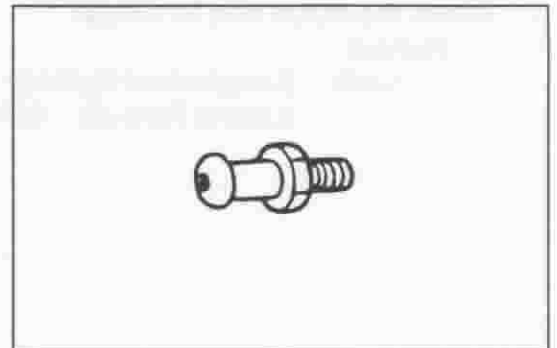

JCL00036-00028

MAIN POINTS OF INSTALLATION

1. Thinly apply EP grease to the clutch release fork or the entire periphery of the sliding surface of the clutch release bearing hub assembly.
2. Install the release bearing hub clip to the clutch release fork.

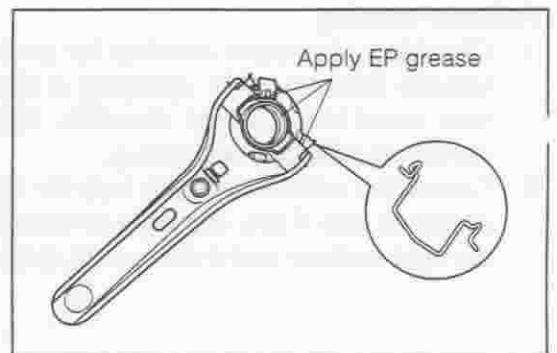

JCL00037-00029

3. Apply EP grease to the entire periphery of the sliding surface of the release fork support.



JCL00038-00030

4. Apply clutch grease to the entire inner periphery of the clutch release bearing hub assembly. Install the clutch release fork to the transmission.

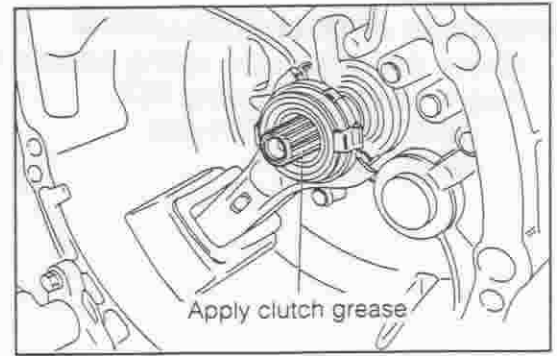

5. Thinly apply clutch grease to the spline section of the clutch disc assembly.

NOTE:

- The grease should be applied from the clutch cover side. Be sure to apply the grease as sparsely as possible so that no excess grease may ooze out to the flywheel side.

Specified Amount: 0.1 - 0.2 g

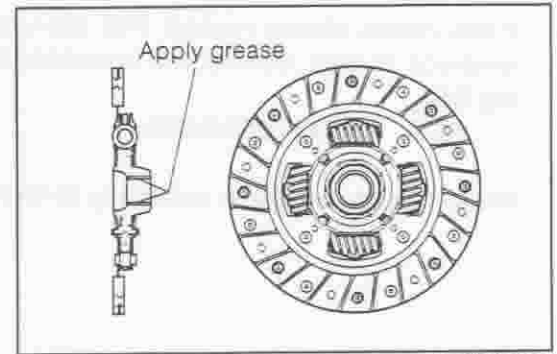

6. With the clutch disc assembly placed at the center position by means of the following SST, install the clutch disc assembly to the flywheel.

SST: 09301-87703-000

NOTE:

- Be very careful not to mistake the installation direction of the clutch disc assembly.

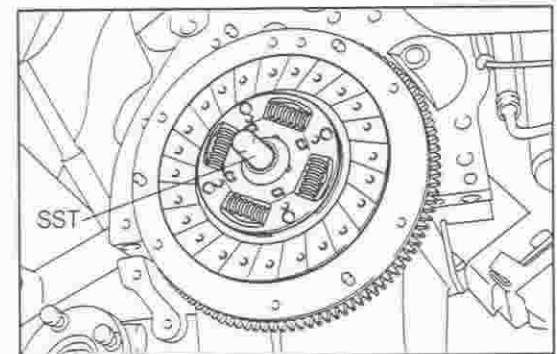

7. Install the clutch cover assembly, aligning with the locating pins of the flywheel at three points. Tighten the six bolts to the specified torque, while preventing the flywheel from turning by means of the following SST.

SST: 09210-87701-000

NOTE:

- As for the tightening sequence of the bolts, first temporarily tighten the bolt ①. Then, fully tighten the bolts in order of ② - ③ - ① - ④ - ⑤ - ⑥. (Here, any bolt can be the bolt ①.)

Tightening Torque: 14.7 - 21.6 N·m (1.5 - 2.2 kgf·m)

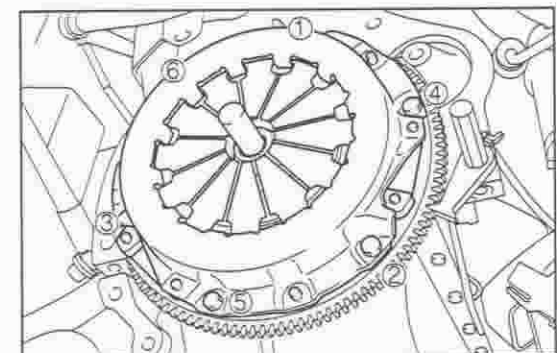

OPERATION AFTER INSTALLATION

1. Check the diaphragm spring section for unevenness in height, using the following SST.

SST: 09210-87701-000
 Limit: 0.6 mm

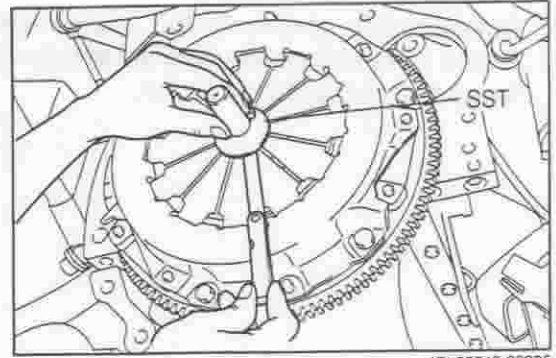

2. If the check above reveals that the unevenness in height exceeds its limit, correct the unevenness, using the following SST.

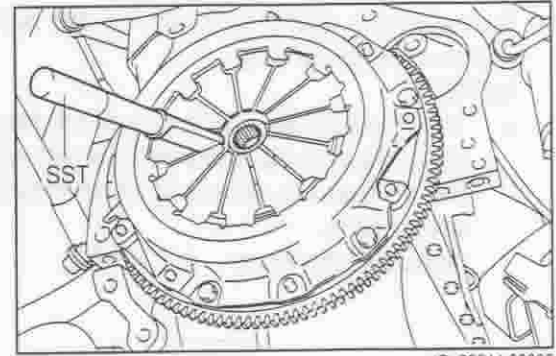

SST: 09333-00016-000

3. Install the transmission assembly to the vehicle.

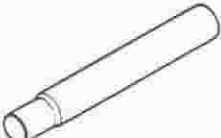

APPENDIX

SSTs (Special Service Tools)

Illustration	Tool No.	Tool name
	09210-87701-000	Flywheel holder
	09301-87703-000	Clutch guide tool
	09302-87702-000	Clutch diaphragm spring height gauge No. 4
	09333-00013-000	Clutch diaphragm spring aligner

JCL00045-00037

TIGHTENING TORQUE

Tightening components	N·m	kgf·m
Pedal height adjusting nut	11.8 - 27.5	1.2 - 2.8
Push rod adjusting nut	14.7 - 21.6	1.5 - 2.2
Release cylinder bleeder plug	8.82 - 12.74	0.9 - 1.3
Pedal shaft attaching nut	10.3 - 24.0	1.05 - 2.45
Pedal bracket x Body	9.8 - 15.7	1.0 - 1.6
Master cylinder x Pedal bracket	14.7 - 21.6	1.5 - 2.2
Release cylinder x Transaxle case	11.55 - 18.45	1.2 - 1.9
Hose release cylinder x Release cylinder	18.6 - 30.4	1.9 - 3.1
Tube flare nut	12.7 - 17.6	1.3 - 1.8
Bracket reservoir x Body	6.9 - 9.8	0.7 - 1.0
Clutch cover x Flywheel	14.8 - 21.6	1.5 - 2.2
Clutch release fork support x Clutch housing	14.8 - 21.6	1.5 - 2.2

JCL00046-00000