

GENERAL INFORMATION

IMPORTANT SAFETY NOTICE	GI-2
HOW TO USE THIS MANUAL	GI-4
ABBREVIATION CODES	GI-6
GENERAL SERVICE INSTRUCTION	GI-8
ENGINE NUMBER AND ENGINE TYPE	
STAMPED POSITIONS	GI-9

JG:00001-00000

IMPORTANT SAFETY NOTICE

The vehicle is a machine comprising a great number of parts. Basically speaking, the vehicle is potentially hazardous. However, one can handle it safely if he has the required knowledge.

Correct service methods and repair procedures are very vital for assuring not only the safety and reliability of a vehicle, but also the safety of service personnel concerned.

The methods and procedures contained in this manual describe in a general way the techniques which the manufacturer has recommended. Thus, they will contribute to ensuring the reliability of the products. The contents of the servicing operations come in a wide variety of ways. Moreover, techniques, tools and parts necessary for each operation are different widely from each other.

This manual does not cover all details of techniques, procedures, parts, tools and handling instructions which are necessary for these operations, for such coverage is impossible. Hence, any one who obtains this manual is expected first to make his responsible selection as to techniques, tools and parts which are necessary for servicing the vehicle concerned properly. Furthermore, he must assume responsibility for his actions in connection with his own safety.

Therefore, one should not perform any service if he is not capable of making responsible selection and/or if he can not understand the contents herein described, for this manual has been prepared for experienced service personnel.

WARNINGS, CAUTIONS AND NOTES

All these symbols have their specific purposes, respectively.

WARNING:

- This symbol means that there is the possibility of personal injury of the operator himself or the nearby workers if the operator fails to follow the operating procedure prescribed in this manual.

CAUTION:

- This symbol means that there is the possibility of damage to the component being repaired if the operator fails to follow the operating procedure prescribed in this manual.

NOTE:

- To accomplish the operation in an efficient manner, additional instructions concerning the operation are given in this section.

The following list describes general WARNINGS:

- Always wear safety glasses for eye protection.
- Use safety stands whenever a procedure requires you to be under the vehicle.
- Be sure that the ignition switch is always in the OFF position, unless otherwise required by the procedure.
- Set the parking brake when working on the vehicle.
- Operate the engine only in a well-ventilated area to avoid the danger of carbon monoxide.
- Keep yourself and your clothing away from moving parts, when the engine is running, especially from the fan and belts.
- To prevent serious burns, avoid contact with hot metal parts such as the radiator, exhaust manifold, tail pipe, catalytic converter and muffler.
- Do not smoke while working on a vehicle.
- To avoid injury, always remove rings, watches, loose hanging jewelry, and loose clothing before beginning to work on a vehicle.
- Keep hands and other objects clear of the radiator fan blades! The electric cooling fan is mounted on the radiator and can start to operate at anytime by a rise in coolant temperature.

or turning ON of the air conditioner switch in the case of vehicles equipped with an air conditioner. The electric cooling fan is also mounted on the condenser for air conditioner and starts to operate anytime when the air conditioner switch is turned "ON". For this reason care should be taken to ensure that the electric cooling fan motor is completely disconnected when working under the hood.

The UNITS used in this manual are showed as the SI UNIT (International System of Unit).

"Example"

24.5 - 34.3 N·m

JG100002-00000



HOW TO USE THIS MANUAL

CONTENTS OF EXPLANATION

1. Schematic Diagram of Components

- (1) The schematic diagram of components that appears at the beginning of each section describes the nomenclature and installed conditions of each component. Furthermore the tightening torque is posted in the figure.
- (2) Those parts whose reuse is not permitted bear a "★" mark for an identification purpose. Be certain to replace these parts with new ones during the assembly.
- (3) During the assembly, be sure to apply grease to those parts indicated by the mark in the figure.

(Example)

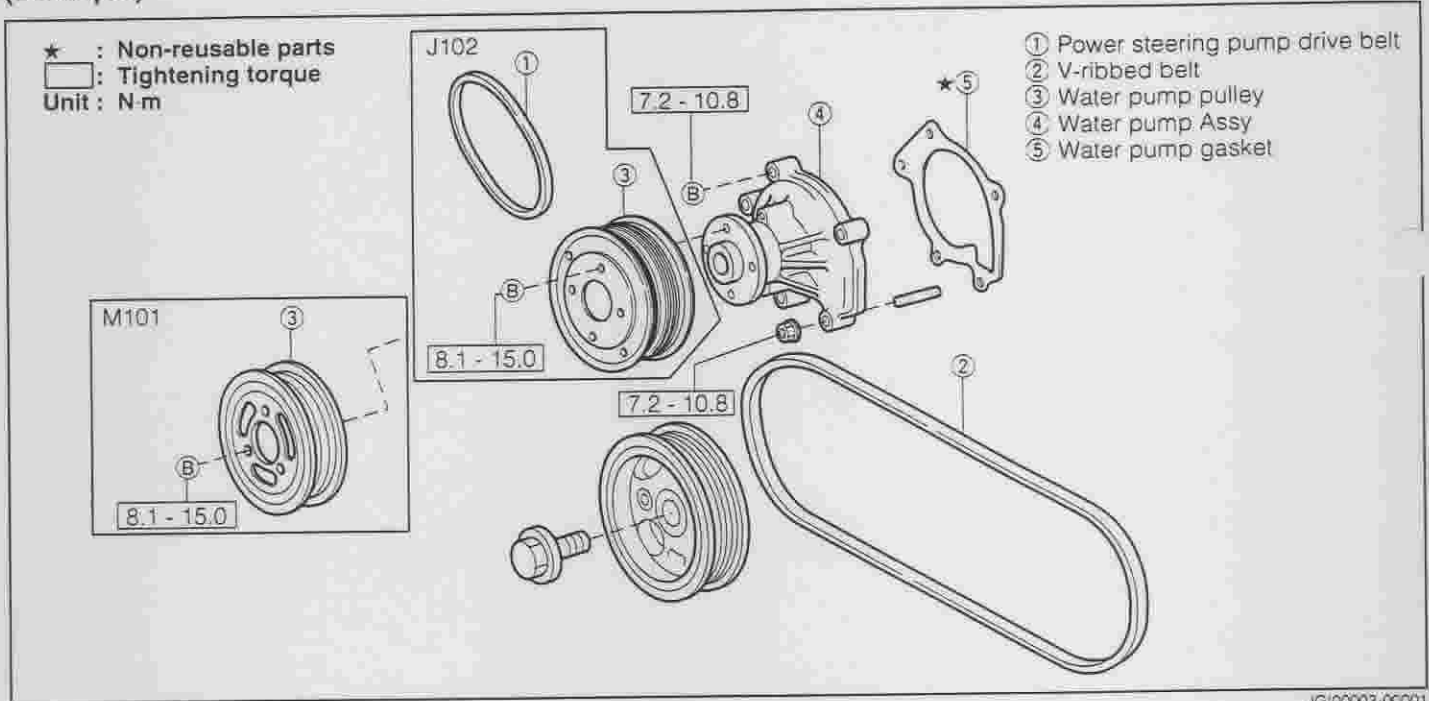

2. Servicing Procedure

- (1) In principle, the servicing procedure is described in the following sequence given below: Removal → Inspection → Installation, and Disassembly → Inspection → Assembly.
- (2) The explanation covers detailed servicing methods, specifications and notes.
- (3) The main point of each item explains the servicing section and servicing procedure, using illustrations.

(Example)

DISASSEMBLY

1. Remove the alternator pulley lock nut by means of an impact wrench, while holding the shaft by using a hexagonal box wrench.

NOTE:

- Be sure to use an impact wrench having a hexagonal hole.

What to do

What to do
and where

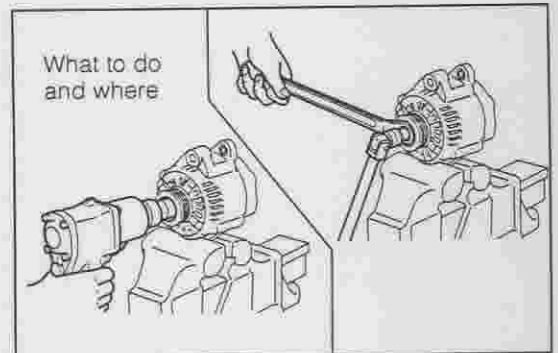

(4) The inspection in this manual describes only checking operation. Therefore, if you find any malfunction, replace any defective parts with new ones.

3. SST

For those operations which require the use of any SST, the SST numbers concerned are given in bold letters.

4. Service Specifications

Service specifications are indicated in bold letters or enclosed by heavy lines. Be certain to confirm the specifications concerned.

5. Tightening Torque

For those operations which require the control of tightening torque, the relevant tightening torque is given in bold letters. Be certain to confirm the tightening torque concerned.

6. Definitions of Terms

Specified Value A value which represents the allowable range during the inspection and adjustment.

Limit A maximum or a minimum limit which the value should not exceed or fall below.

JG100005-00000

ABBREVIATION CODES

The abbreviation codes that appear in this service manual stand for the following, respectively.

Abbreviation code	Original word	Meaning
ABS	Anti-lock Brake System	Refers to anti-lock brake system
A/C	Air Conditioner	Refers to air conditioner.
API	American Petroleum Institute	The standards set forth by the American Petroleum Institute (abbreviated as API Classification) have been employed to evaluate and classify properties of various oils. Engine oils for gasoline engines are classified as SG, SH, SJ and so on, whereas engine oils for diesel engines are classified as CC, CD and so on.
Assy, A/Y or Ay	Assembly	Refers to an assembled component comprising more than two single parts or sub-assembly parts.
A/T, AT	Automatic Transmission	Refers to automatic transmission
ATDC	After Top Dead Center	Refers to after top dead center
BTDC	Before Top Dead Center	Refers to before top dead center
CARB	California Air Resources Board	Refers to California Air Resources Board
DLC	Data Link Connector	Has the same meaning as a check engine connector.
DLI	Distributor Less Ignition	Refers to distributor less ignition
DTC	Diagnostic Trouble Code	Denotes a malfunction code.
DVVT	Dynamic Variable Valve Timing	Refers to Dynamic Variable Valve Timing
ECU	Electronic Control Unit	Refers to electronic control unit.
EFI	Electronic Fuel Injection	Refers to electronic fuel injection.
ESA	Electronic Spark Advance	Refers to electronic spark advance
EX	Exhaust	Refers to exhaust
F/L	Fusible Link	Refers to fusible link.
GND	Ground	Refers to body ground
HC	Hydro Carbon	Refers to hydro carbon
IGN	Ignition	Refers to ignition
IN	Intake	Refers to intake
ISC	Idle Speed Control	Refers to idle speed control
ISO	International Organization for Standardization	Refers to International Organization for Standardization
LH	Left Hand	Refers to left side.
LHD, L.H.D.	Left-Hand Drive	Left-hand drive vehicle.
MIL	Malfunction Indicator Lamp	Has the same meaning as a diagnosis lamp.
MT, M/T	Manual Transmission	Refers to manual transmission.
NOx	Nitrogen Oxides	Refers to nitrogen oxides
O/S	Oversize	In instances where fitting becomes too loose due to wear resulting from use for a long period of time or due to frequent removal/installation operations, if the fitting part (e.g. piston) is replaced with a part having larger dimensions, the other mating part may be put into use again. "Oversized" parts denote those parts having larger dimensions compared with the standard parts.
OCV	Oil Control Valve	Refers to Oil Control Valve
PCV	Positive Crankcase Ventilation	Refers to positive crankcase ventilation.
RH	Right Hand	Refers to right side.

Abbreviation code	Original word	Meaning
RHD, R.H.D.	Right-Hand Drive	Right hand drive vehicle
S/A	Sub-Assembly	Refers to a component comprising more than two single parts which are welded, staked, or studded to each other to form a single component.
SAE	Society of Automotive Engineers	For example, automotive oils are designated as SAE so and so number. These designation numbers have been set forth by the Society of Automotive Engineers in the United States of America (SAE). The larger the SAE number, the higher the oil viscosity. Conversely, the smaller the SAE number, the lower the oil viscosity.
SST	Special Service Tool	Refers to a tool designed for a specific purpose.
STD	Standard	When referring to automotive parts, "standard" represents those parts which have been installed originally by the manufacturer and which have standard dimensions.
T	Torque	Refers to tightening torque.
TDC	Top Dead Center	Refers to top dead center
U/S	Under Size	In the same manner as with the "oversized" parts, if fitting part (e.g. bush and bearing) is replaced with a part having smaller bore dimensions, the other mating part may be put into use again. "Under sized" parts denote those parts having smaller dimensions compared with standard parts.
W/	With	Denotes that the following part is attached.

JG100006-00000

The abbreviation codes that appear in the figure stand for the following, respectively.

Ⓑ	Bolt	Ⓢ	Screw
Ⓝ	Nut	Ⓦ	Washer

JG100007-00000

GENERAL SERVICE INSTRUCTION

1. Use fender covers, seat covers and floor sheets so that the vehicle may not get dirty or be scratched.
2. Jacking up
 - (1) When only the front section or rear section of the vehicle is jacked up, be sure to place chocks at the wheels so as to insure safe operations.
 - (2) When the vehicle has been jacked up, be sure to support the vehicle at the specified section using the safety stands. (Refer to the relevant Chassis section in the manual for the vehicle concerned.)
3. Handling instructions related to battery.
 - (1) Before you start performing the electrical works, make certain to disconnect the battery ground cable terminal from the negative (-) terminal of the battery.

NOTE:

 - Before disconnecting the battery ground cable terminal from the negative (-) terminal of the battery, be sure to read out the diagnosis code of the EFI system if it is equipped.
 - After reconnecting the battery ground cable terminal to the negative terminal of the battery, be sure to reset the watch or radio, if the vehicle is equipped with such equipment.
 - (2) When it becomes necessary to disconnect the battery power supply for the purpose of carrying out checks or repairs, always disconnect the negative (-) terminal of the battery ground cable from the negative terminal of the battery first.
 - (3) To avoid damaging battery plates, after the terminal nut has been loosened, pull out the battery ground cable terminal straight upward, rather than turning or prying the terminal.

NOTE:

 - Be sure to employ a battery terminal puller (commercially available) to remove the battery ground cable terminal from the negative terminal of the battery, if any difficulty is encountered.
 - (4) Clean the battery terminal posts or battery ground terminals, using a cloth. Never use a file or other adhesive agents.
 - (5) When connecting the battery ground cable terminal to the battery, first the battery ground cable terminal should be fitted onto the battery post with the attaching nut in a loose state. Then, tighten the nut. Never tap the terminal onto the battery post, using a hammer, a spanner wrench or the like.
 - (6) As for the cover at the positive (+) terminal side, be sure to install it at the correct position.
4. Repairing of fuel system
 - (1) The EFI-equipped vehicles employ a high fuel pressure. Therefore, the following notes should be observed.
 - ① Be sure to prevent the fuel from splashing with a cloth or the like, when the union bolt or other connected section of the fuel line is loosened or slackened.
 - (2) When connecting/disconnecting the fuel line.
 - ① Tighten each connecting section to the specified torque.
 - ② Attach new specified clips to each connecting section.
 - ③ Be certain to place a suitable container, a cloth, etc. under the connected section of the fuel line before disconnecting the fuel line.
 - ④ Before the fuel line is disconnected, be sure to release the inner pressure of the fuel tank by detaching the fuel filler cap.
 - (3) Do not work near open flames.
5. For increased work efficiency and improved accuracy, be sure to utilize the SSTs (Special Service Tools) effectively.

JG100008-00000

ENGINE NUMBER AND ENGINE TYPE STAMPED POSITIONS

- The engine number is stamped on the cylinder block.
- The engine type is indicated by embossed letters on the cylinder block.

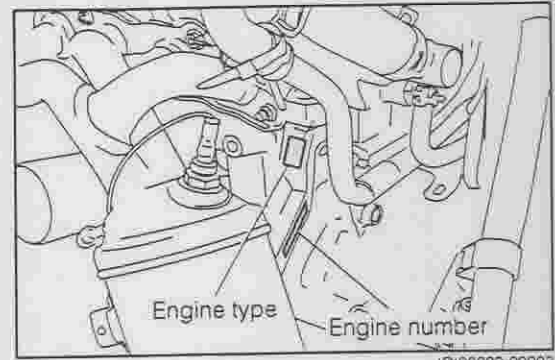

JG100009-00003