

# **REPAIR MANUAL**

**4 HP - 22**



**ZF GETRIEBE GMBH SAARBRÜCKEN**

# INDEX

	Page
<b>PRE-INFORMATION</b>	1
1. General Notes	2
1.1 Picture of Transmission	2
1.2 Power Flow Schedule	3
1.4 Adjustment Data	5/1
1.4.1 Position of Valve Body	5/1
Adjustment of kick-down cable	
1.4.2 Determination of Axle Clearance	5/2
1.5 Tightening torques	6
1.6 Fault finding table	7/1
1.7 Checking of Transmission	8
1.8 Special Tools	9/1
2. Disassembling	10
2.1 Disassembling after sequence	10
2.2 4th Gear Assembly	18
2.2.1 Output with Freewheel	20
2.2.2 Brake F	22
2.2.3 Clutch E	24
2.3 Planetary Set with Web Shaft and Brakes C', C and D	25
2.4 Clutch B	32
2.5 Clutch A	34
2.6 Bellhousing with Intermediate Plate and Pump	36
2.7 Transmission Extension and Centrifugal Governor	36
2.8 Transmission Case with shift selection	38
3. Assembly	41
3.1 Transmission Case with Selector and Park	41
3.2 Brake F	44
3.3 Clutch E	46
3.4 Mounting and Assembly of 4th Gear Complete	49
3.5 Park Mechanism	55
3.6 Planetary Set 4th Gear	57
3.7 Web Shaft with Planetary Set	59
3.8 Cylinder C-D	63
3.9 Brake D with Freewheel 1. Gear	65
3.10 Brake C', C	67
3.11 Clutch B	71
3.12 Clutch A	73
3.13 Pump Intermediate Plate and Bell Housing	77
3.14 Governor and Transmission Extension	81
3.15 Valve Body, Oil Pan and Torque Converter	86



# PRE-INFORMATION

This manual contains the exact work procedure to repair transmission 4 HP 22

Disassembly and assembly of the transmission is explained in chronological order.

Depending on the failure, the repair of the transmission can be done as necessary.

Therefore, we recommend the following points:

- Kick-down cable, gaskets, o-rings, sealings, and sealing bushings should always be replaced.
- If transmission has high mileage (over 31,250 miles 50,000 km)replace all clutch and steel plates.
- After clutch breakdown in a transmission, it is absolutely necessary to clean torque converter, oil cooler, and oil cooler hoses with appropriate cleaning material.
- All adjustments which are necessary during transmission assembly should be done as explained in point 1.4.

There are the following requirements:

- Special tools to repair transmission listed under 1.8 is the complete set of special tools.
- Suitable test stand.  
The necessary technical data is available in the ZF "Circular Letter".

## **Note:**

Valve body should not be repaired without special training.  
Replace valve body as a complete unit.  
A separate repair manual is available for valve body repair.

## **Attention:**

Transmission should only be shipped with the oil quantity listed in the respective part number listing (microfiche).

1. General notes

1.1 Picture of Transmission

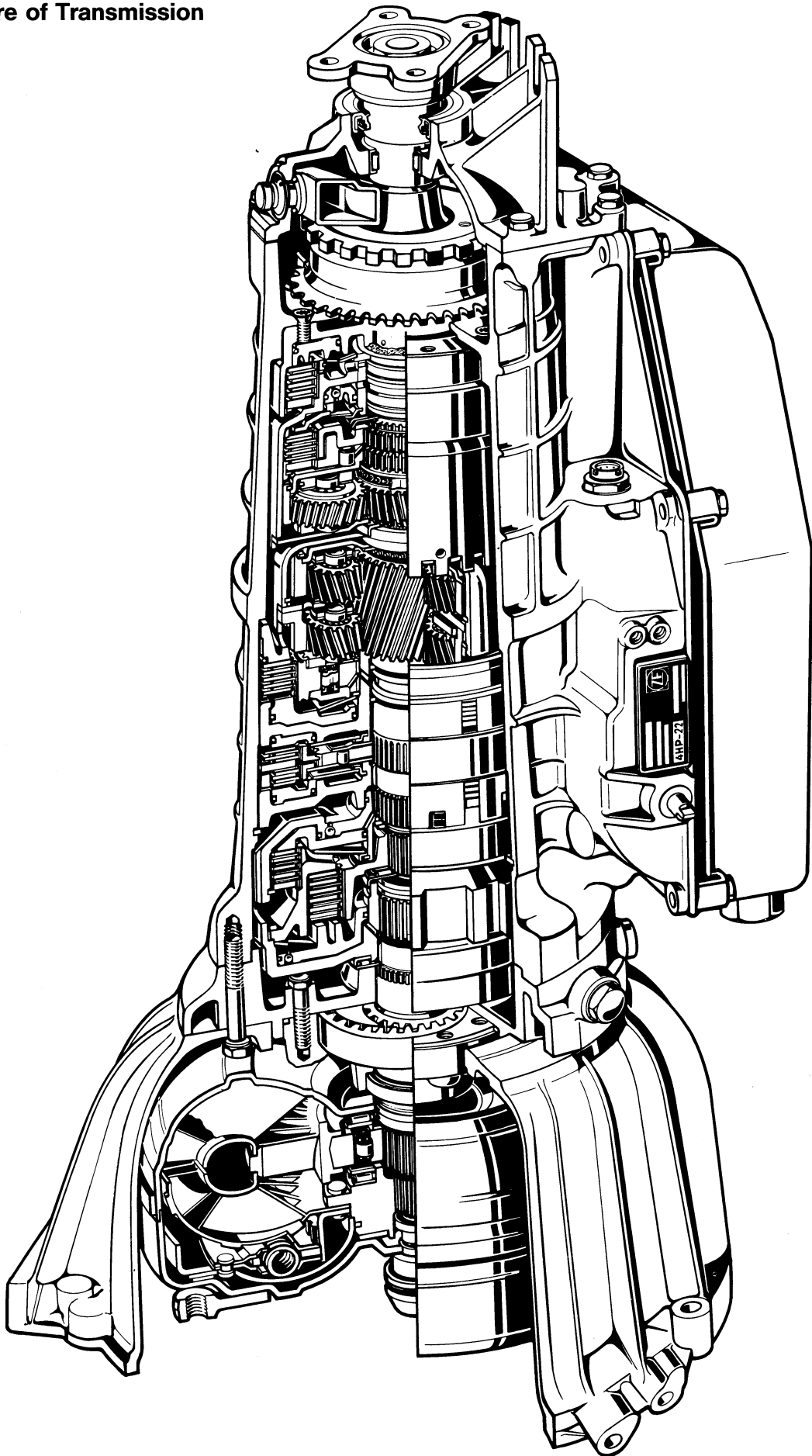

## 1.2 Power Flow Schedule

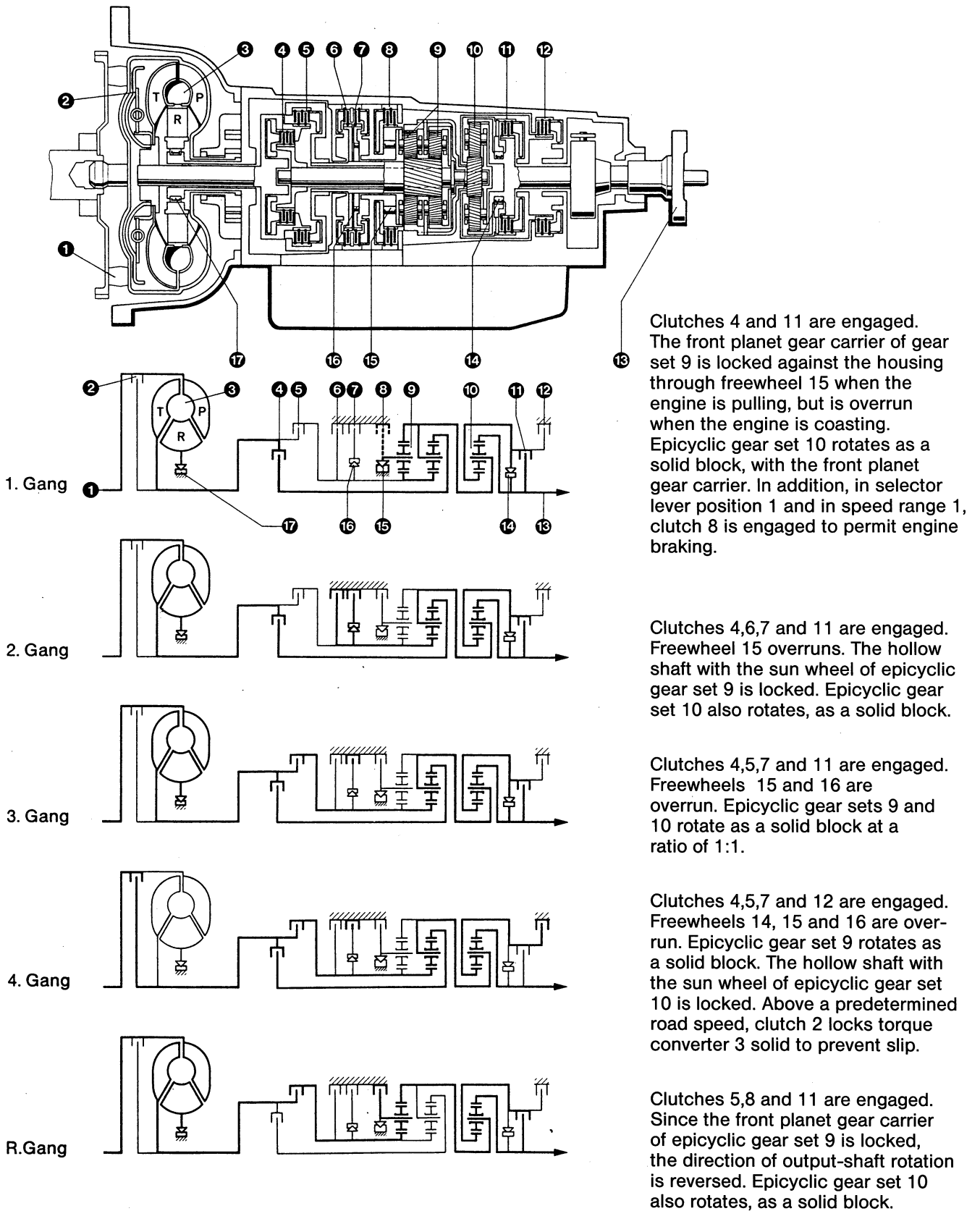



## 1.4 Adjustment Data

### 1.4.1 Positioning of Valve Body, Adjustment of Kick-down Cable (full throttle)

Insert 13 connecting bolts for tightening of valve body screw in loosely by hand.

Insert special adjustment tool 5 P 89 001 673 between pin of throttle pressure piston and throttle pressure housing as shown in picture.

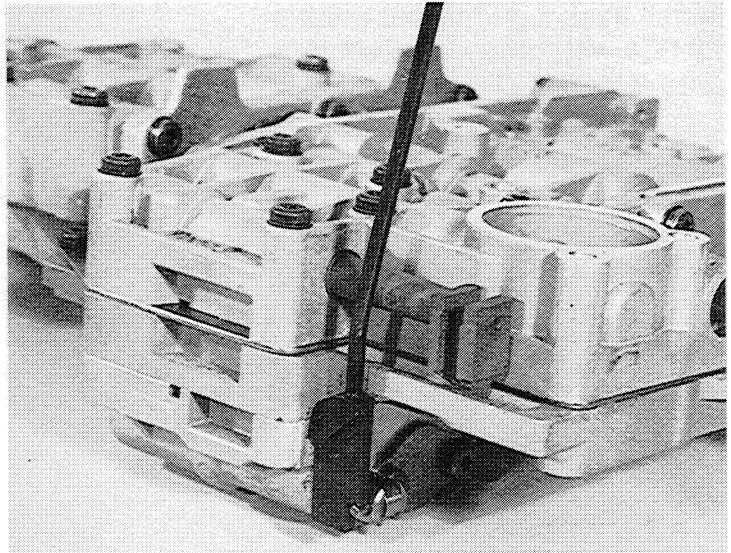

82 186

Lightly press valve body unit against special tool.

In that position tighten all connecting bolts of valve body. Tightening of bolts should be done from inside to outside.

(To be torqued - 8 Nm)

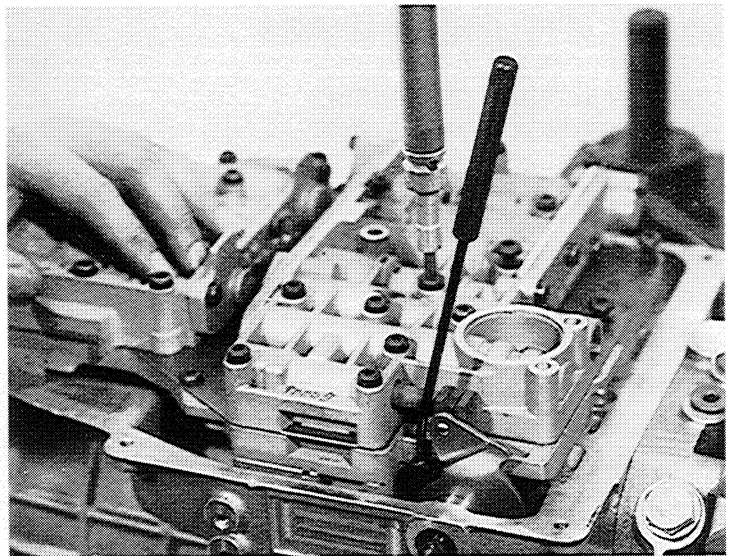

82 187

Straighten out kick-down cable. Pull cable through position full throttle. Do not pull kick-down.

Set seal X mm according to transmission types.

Alignment information available in ZF Technical Circular Letter (or microfiches).

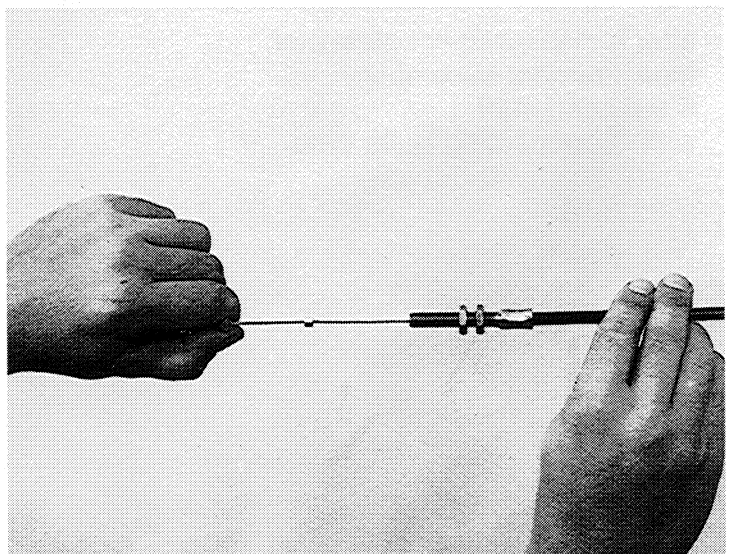

Install gasket and thrust washer 22 024 with grease (Vaseline) onto intermediate plate.

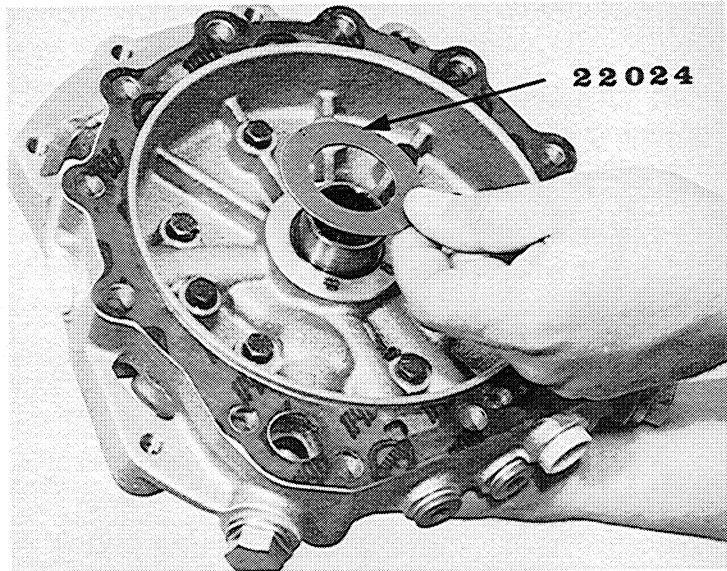

82 164

Use grease (Vaseline) on input shaft, piston ring seats.

Install bell housing together with intermediate plate, align carefully against transmission case.



82 165

**Attention:**

To determine the correct measurement it is absolutely necessary that

- all 12 hexagon bolts are tightened according to manufacturer's instructions, to be torqued 46 Nm (pressing of gasket).
- attach measurement sleeve of measurement assembly 5 P 01 001 415 with 3 connecting bolts onto stator shaft without any clearance.

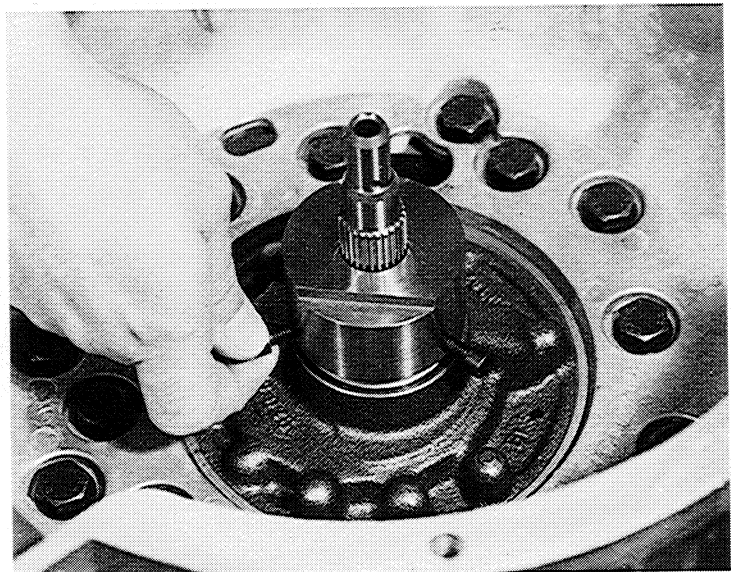

Also attach measurement gauge 5 P 01 001 415 onto teeth of input shaft and secure gauge with locking nut.

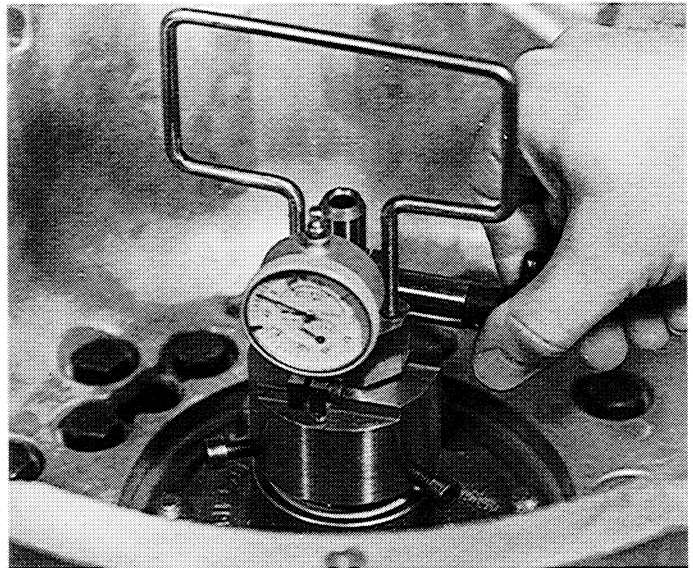

When pulling up handle, axial clearance will be shown on gauge (repeat measurement).

Axial clearance should be 0,2 - 0,4 mm

If axial clearance is not correct, unscrew complete bell housing assembly and use either thinner or thicker thrust washer 22 024. Afterwards check axial clearance again.

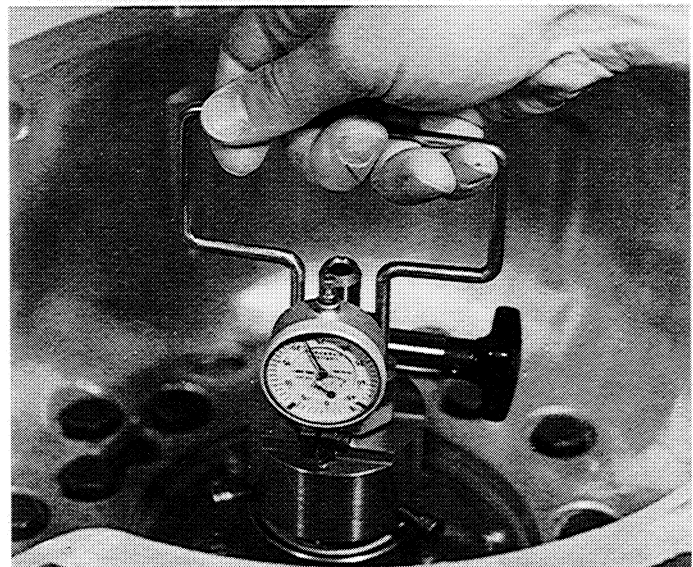

## 1.5. Tightening Torques

Description		Page	To be torqued
Counter Sunk Bolts of Cylinder F	- M6	55	10 Nm
Cylindrical Bolts of Park Assembly	- M6	56	10 Nm
Hexagon Bolts of Pump Assembly	- M6	78	10 Nm
Plugs of Intermediate Plate	- M20	78	50 Nm
Plugs of Intermediate Plate	- M14	78	40 Nm
Hexagon Bolts of Bell housing Assembly	- M10	80	46 Nm
Cylindrical Bolts of Governor Housing and Hub	- M6	82	10 Nm
Hexagon Bolts of Extension housing	- M8	85	23 Nm
Collar Nut for tightening of Output Flange	- M20	85	100 Nm
Cylindrical Bolts for tightening of Valve Body	- M6	88	6 Nm
Drain Plug for Oil Pan	- M10	89	15 Nm
Cap Nut of Oil Pan	- M24	89	20 Nm
Tightening Bolts of Oil Pan	- M6	89	8 Nm



## 1.6. FAULT FINDING TABLE AUTOMATIC GEARBOX - TYPE 4 HP 22

The following table is intended as a guide to diagnosis of faults which may occur in the 4 HP 22.

The problems have been written down as customers would describe them. Descriptions will of course vary, but it is up to the technicals people to interpret and diagnose the fault.

If the customer complains of leakage, then check for the leak point before carrying out any further work. De-greasing products such as 'Jizer' should be thoroughly used to clean the unit, then after a short road test, it should be possible to locate the leak point.

### INITIAL CHECKS

- correct oil level
- correct setting of throttle cable
- Idling             Seal             0,5 mm from end of cover
- Full Throttle     Seal             39,0 mm from end of cover
- Kick-down        Seal             43,5 mm from end of cover
- correct setting of selector lever
- clean oil cooler and pipes whenever gearbox is changed

## Fault Finding Table for Gearbox 4 HP 22

Fault	Possible Cause	Corrective Measures
<b>1. Position P</b> 1.1 Parking does not engage	<ul style="list-style-type: none"> <li>- wrong setting of gear change rods between control lever and gearbox</li> <li>- too much friction in parking lock mechanism</li> </ul>	<ul style="list-style-type: none"> <li>- correct setting</li> <li>- replace parts (cam and connection rod, eventually pawl)</li> </ul>
1.2 Parking position does not hold	<ul style="list-style-type: none"> <li>- wrong setting of gear change rods between control lever and gearbox</li> </ul>	<ul style="list-style-type: none"> <li>- correct setting</li> </ul>
1.3 Engine cannot be started	<ul style="list-style-type: none"> <li>- starter inhibitor switch faulty</li> <li>- wrong setting of selector lever</li> <li>- faulty selector lever</li> </ul>	<ul style="list-style-type: none"> <li>- replace switch</li> <li>- correct setting</li> <li>- replace lever</li> </ul>
<b>2. Position R</b> 2.1 No reserve gear	<ul style="list-style-type: none"> <li>- wrong setting of gear change rods between control lever and gearbox</li> <li>- dirty oil filter</li> <li>- clutch B destroyed, in this case no 3rd gear</li> <li>- clutch D destroyed, no engine braking in Position 1, 1st gear</li> <li>- clutch E destroyed, no engine braking in 2nd + 3rd gear, also in Pos 1, 1st gear</li> <li>- reverse gear safety valve faulty</li> </ul>	<ul style="list-style-type: none"> <li>- correct setting</li> <li>- see 11.2</li> <li>- replace transmission</li> <li>- replace transmission</li> <li>- replace transmission</li> <li>- replace control unit</li> </ul>
2.2 Slipping or shaking at start in reverse gear	<ul style="list-style-type: none"> <li>- clutch B or E brake D defective</li> </ul>	<ul style="list-style-type: none"> <li>- replace gearbox</li> </ul>
2.3 Strong jerk when putting in positions P-R or N-R, or distinct double jerk at P-R or N-R (below 1500 RPM engine speed)	<ul style="list-style-type: none"> <li>- damper B defective (will give the same symptoms when changing from 2nd to 3rd gear)</li> </ul>	<ul style="list-style-type: none"> <li>- replace control unit</li> </ul>
2.4 Reverse light does not illuminate (bulbs, fuses and cables ok)	<ul style="list-style-type: none"> <li>- see 1.3</li> </ul>	<ul style="list-style-type: none"> <li>- see 1.3</li> </ul>

## Fault Finding Table for Gearbox 4 HP 22

Fault	Possible Cause	Corrective Measures
<b>3. Position N</b> 3.1 Engine cannot be started	<ul style="list-style-type: none"> <li>- see 1.3</li> </ul>	<ul style="list-style-type: none"> <li>- see 1.3</li> </ul>
3.2 Vehicle moves in Position N	<ul style="list-style-type: none"> <li>- wrong setting of gear change rods between control lever and gearbox</li> <li>- clutch A defective (seized up)</li> </ul>	<ul style="list-style-type: none"> <li>- correct setting</li> <li>- replace transmission</li> </ul>
<b>4. Position D</b> 4.1 No drive	<ul style="list-style-type: none"> <li>- dirty oil filter</li> <li>- clutch A defective</li> <li>- one way clutch 1st gear slips</li> <li>- wrong setting of gear change rods between control lever and gearbox</li> </ul>	<ul style="list-style-type: none"> <li>- see 11.2</li> <li>- replace transmission</li> <li>- replace transmission</li> <li>- correct setting</li> </ul>
4.2 Slipping or shaking at starting forward	<ul style="list-style-type: none"> <li>- clutch A damaged</li> </ul>	<ul style="list-style-type: none"> <li>- replace gearbox</li> </ul>
4.3 Strong jerk N-D (below 1500 RPM engine speed)	<ul style="list-style-type: none"> <li>- clutch A faulty</li> <li>- clutch A damper faulty</li> </ul>	<ul style="list-style-type: none"> <li>- replace transmission</li> <li>- replace control unit</li> </ul>
4.4 Gear change functions (in cold or warm state) faulty <ul style="list-style-type: none"> <li>- Change 1-2/2-1</li> <li>- Change 1-2</li> <li>- Change 2-3/3-2</li> <li>- Change 2-3</li> <li>- Change 3-4/4-3</li> <li>- Change 3-4</li> </ul>	<ul style="list-style-type: none"> <li>- governor dirty</li> <li>- shift valve 1-2 sticking</li> <li>- brake C' and/or C faulty</li> <li>- governor dirty</li> <li>- shift valve 2-3 sticking</li> <li>- clutch B faulty</li> <li>- governor dirty</li> <li>- shift valve 3-4 sticking</li> <li>- brake F defektive</li> </ul>	<ul style="list-style-type: none"> <li>- replace governor</li> <li>- replace control unit</li> <li>- replace gearbox</li> <li>- replace governor</li> <li>- replace control unit</li> <li>- replace gearbox</li> <li>- replace governor</li> <li>- replace control unit</li> <li>- replace gearbox</li> </ul>
4.5 Vehicle starts in 2nd gear  Vehicle starts in 3rd gear  Gearbox changes 1-3	<ul style="list-style-type: none"> <li>- governor sleeve sticking</li> <li>- shift valve 1-2 sticking</li> <li>- governor sleeve sticking</li> <li>- shift valve 1-2 and 2-3 sticking</li> <li>- shift valve 2-3 sticking</li> </ul>	<ul style="list-style-type: none"> <li>- replace governor</li> <li>- replace control unit</li> <li>- replace governor</li> <li>- replace control unit</li> <li>- replace control unit</li> </ul>



## Fault Finding Table for Gearbox 4 HP 22

Fault	Possible Cause	Corrective Measures
<b>4.6 Shift speeds</b> - no changes at light throttle setting - change points incorrect at full throttle setting - no changes at Kick-Down 1-2/2-1 - no changes at Kick-down 2-3/3-2 - no changes at Kick-Down 4-3	- dirty governor - shift valves sticking - throttle cable setting incorrect - throttle cable setting incorrect - throttle cable setting incorrect - 4-3 Kick-Down valve sticking	- replace governor - replace control unit - correct setting - correct setting - korrekt setting - replace control unit
<b>4.7 Gear change quality</b> - harsh changes at low throttle - soft changes at full throttle and Kick-Down - harsh changes at full throttle and Kick-Down	- defective damper - modulation pressure too high - clutch plates damaged - defektive damper - modulation pressure too low - clutch plates damaged - incorrect modulation pressure - defective damper	- replace control unit - replace control unit - replace gearbox - replace control unit - replace control unit - replace gearbox - replace control unit - replace control unit
<b>5. Position 3, 3rd Gear</b> 5.1 No engine braking	- clutch E damaged	- replace gearbox
<b>6. Position 2</b> 6.1 Manual change 3-2 faulty	- locking valve 2 sticking - governor sticking	- replace control unit - replace governor
6.2 No engine braking	- brake C' or clutch E damaged	- replace gearbox
<b>7. Position 1</b> 7.1 Manual change 2-1 faulty	- locking valve 1 sticking - governor sticking	- replace control unit - replace governor
7.2 No engine braking	- brake D or clutch E damaged	- replace gearbox

## Fault Finding Table for Gearbox 4 HP 22

Fault	Possible Cause	Corrective Measures
<b>8. Lock-Up Clutch = WK</b> 8.1 Change points incorrect	<ul style="list-style-type: none"> <li>- WK safety valve sticking</li> <li>- no 4th gear</li> <li>- governor pressure incorrect</li> </ul>	<ul style="list-style-type: none"> <li>- replace control unit</li> <li>- replace control unit</li> <li>- replace governor</li> </ul>
8.2 Gear change too harsh	<ul style="list-style-type: none"> <li>- WK-damper faulty</li> <li>- torque converter faulty</li> </ul>	<ul style="list-style-type: none"> <li>- replace control</li> <li>- replace torque converter</li> </ul>
8.3 No lock-up	<ul style="list-style-type: none"> <li>- control unit faulty</li> <li>- WK faulty</li> <li>- no 4th gear</li> </ul>	<ul style="list-style-type: none"> <li>- replace control unit</li> <li>- replace torque converter</li> <li>- replace control unit</li> </ul>
<b>9. General</b> 9.1 Throttle cable sticking	<ul style="list-style-type: none"> <li>- nipple in throttle cam is worn</li> <li>- too much friction in sleeve of throttle cable</li> <li>- throttle pressure piston sticking</li> </ul>	<ul style="list-style-type: none"> <li>- replace cable</li> <li>- replace cable</li> <li>- replace control unit</li> </ul>
9.2 Noisy and no drive after long journey	<ul style="list-style-type: none"> <li>- oil filter on control unit dirty</li> </ul>	<ul style="list-style-type: none"> <li>- if there is no burnt lining on oil sump, then only replace filter, otherwise replace gearbox</li> </ul>
9.3 Very noisy and no drive	<ul style="list-style-type: none"> <li>- flexi plate is worn</li> <li>- pump drive worn</li> </ul>	<ul style="list-style-type: none"> <li>- replace flexi-plate or torque converter</li> <li>- replace gearbox</li> </ul>
<b>10. Oil Leak</b> 10.1 Oil dripping from bell housing	<ul style="list-style-type: none"> <li>- seal ring in pump housing damaged</li> <li>- pump housing porous</li> <li>- converter leaking from welded seam</li> </ul>	<ul style="list-style-type: none"> <li>- replace seal</li> <li>- replace pump housing</li> <li>- replace converter</li> </ul>
10.2 Leakage between gearbox and oil sump	<ul style="list-style-type: none"> <li>- incorrect torque of bolts</li> <li>- sump gasket damaged</li> </ul>	<ul style="list-style-type: none"> <li>- tighten bolts</li> <li>- replace gasket</li> </ul>

## Fault Finding Table for Gearbox 4 HP 22

Fault	Possible Cause	Corrective Measures
10.3 Leakage between intermediate plate and main housing (esp. at pump pressure point)	<ul style="list-style-type: none"> <li>- bell housing bolts have worked loose</li> </ul>	<ul style="list-style-type: none"> <li>- tighten bolts</li> </ul>
10.4 Oil loss at tacho connection	<ul style="list-style-type: none"> <li>- damaged 'O' ring on tacho</li> <li>- oil seal in tacho faulty</li> </ul>	<ul style="list-style-type: none"> <li>- replace 'O' ring</li> <li>- replace tacho sleeve</li> </ul>
10.5 Oil leak from throttle connection cable	<ul style="list-style-type: none"> <li>- 'O' ring connection damaged</li> </ul>	<ul style="list-style-type: none"> <li>- replace 'O' ring or complete cable</li> </ul>
10.6 Oil leak at output	<ul style="list-style-type: none"> <li>- output oil seal damaged</li> </ul>	<ul style="list-style-type: none"> <li>- replace seal</li> </ul>
10.7 Loss of oil through breather	<ul style="list-style-type: none"> <li>- oil level too high</li> <li>- incorrect oil</li>   <li>- no breather cap</li> <li>- 'O' ring breather damaged</li> <li>- securing clip faulty</li> </ul>	<ul style="list-style-type: none"> <li>- check level</li> <li>- remove gearbox and ensure that it is completely drained (including torque converter oil cooler and pipes)</li> <li>- fit cap or change breather</li> <li>- remove tail housing and replace 'O' ring</li> <li>- replace clip</li> </ul>
10.8 Leakage in cooler pipes	<ul style="list-style-type: none"> <li>- loose connections</li> <li>- pipes damaged</li> <li>- cooler leaks</li> </ul>	<ul style="list-style-type: none"> <li>- re-tighten</li> <li>- replace pipes</li> <li>- replace cooler</li> </ul>
10.9 Oil leak at intermediate plate	<ul style="list-style-type: none"> <li>- blanking plugs loose</li> </ul>	<ul style="list-style-type: none"> <li>- tighten plugs</li> <li>- replace washers</li> </ul>
10.10 Leakage between main housing and tail housing	<ul style="list-style-type: none"> <li>- loose bolts</li> <li>- gasket damaged</li> </ul>	<ul style="list-style-type: none"> <li>- re-tighten</li> <li>- replace gasket</li> </ul>
<b>11. Noises</b> 11.1 High pitched noise in all positions, esp. if oil is cold	<ul style="list-style-type: none"> <li>- low oil level</li> <li>- leaking control unit</li> </ul>	<ul style="list-style-type: none"> <li>- top up as required</li> <li>- replace control unit</li> </ul>



## Fault Finding Table for Gearbox 4 HP 22

Fault	Possible Cause	Corrective Measures
<p>11.2 High-pitched squeaking noise, dependent on engine RPM, in all gears, when oil is warm, accompanied by intermittent drive after a long journey</p>	<ul style="list-style-type: none"> <li>- dirty filter</li> </ul>	<ul style="list-style-type: none"> <li>- if no debris in sump, just replace filter, otherwise replace gearbox</li> </ul>
<p>11.3 Strong noise when in lock-up</p>	<ul style="list-style-type: none"> <li>- torsion damper faulty</li> </ul>	<ul style="list-style-type: none"> <li>- replace torque converter</li> </ul>
<p>11.4 Torsional vibrations from engine when in lock-up</p>	<ul style="list-style-type: none"> <li>- engine RPM is too low, WK shift point incorrect</li> </ul>	<ul style="list-style-type: none"> <li>- replace control unit</li> </ul>

## **1.7 Checking of Transmission (in Vehicle)**

The following points have to be checked:

### **Correct Oil Level**

Oil level control by running engine only (idle speed) in position P.  
The correct oil level can only be checked if oil is warmed up at 80 C.  
Dipstick must be marked between Min- and Max-mark.

### **Oil Level Too Low**

Engine will spin, therefore no power flow in transmission (turbine cannot transmit power).  
Transmission noisy when driving on curvy roads.

### **Correct Adjustment of Engine**

Correct idle rpm, requirement of car manufacturer.

### **Power Flow Forward and Reverse**

Correct linkage adjustment, requirement of car manufacturer.

### **Stall Speed**

Explained under Group 21 Technical Data, Chart, Pressure, Circular Letter to ZF Service Stations.

### **Shift Points**

Explained under Group 21 Technical Data, Chart, Pressure, Folder 401

### **Shift Quality**

Correct kick-down cable adjustment information available under point 16 Function Description.  
Correct adjustment, requirement of car manufacturer.

### **Noise**



#### **Checking Function of Torque Converter Lockup Clutch**

Upshifts 1-2, 2-3, 3-4 by one-quarter pulling of gas pedal.  
The clutch in torque converter should be locked at 85 - 90 km/h when traveling, or 2000 rpm of engine speed. After lockup engine speed will go down approximately 400 rpm.



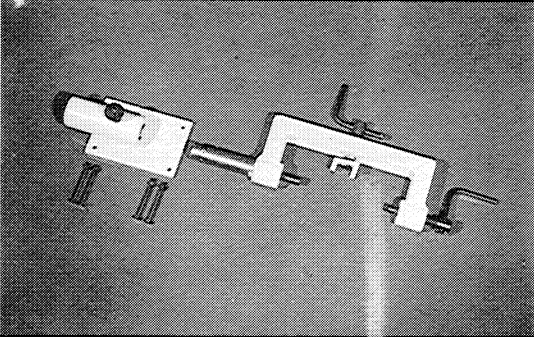
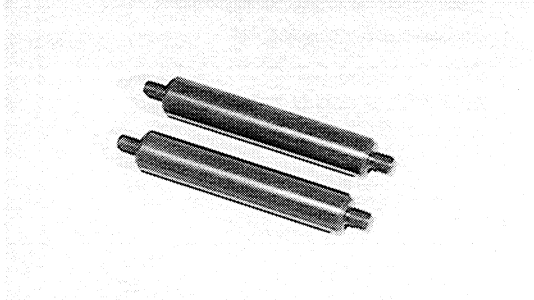
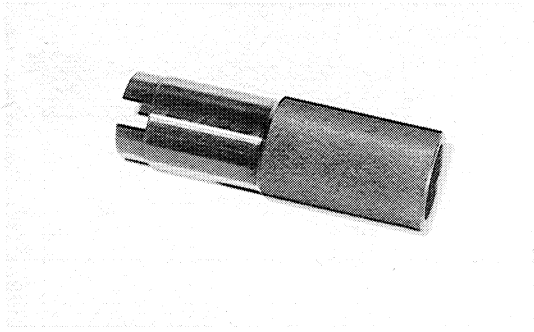

**1.8 Spezialwerkzeuge 4 HP 22**  
**Outils spéciaux 4 HP 22**  
**Special Tools 4 HP 22**

Bild Nr. Photo No Picture	GEGENSTAND OUTIL TOOL	Bestell-Nr. / Verwendungszweck No de commande / Application Part No / Application	Bemerkungen Observations Remarks
	<p>76 051</p> 	<p>5 X 56 000 096</p> <ul style="list-style-type: none"> <li>- Aufnahmebügel für das komplette Getriebe mit Werkbankhalterung</li> <li>- Support pour la boîte complète avec support d'établi</li> <li>- Transmission work bench holding fixture.</li> </ul>	<p>identisch</p> <p>identique</p> <p>identical to 3 HP 22</p>
	<p>76 046</p> 	<p>5 X 56 000 090</p> <ul style="list-style-type: none"> <li>- Wandlerausziehgriffe (2 St.)</li> <li>- Poignées de dépose/repose du convertisseur</li> <li>- Mounting grips (2) for removal and to install convertor</li> </ul>	<p>identisch</p> <p>identique</p> <p>identical to 3 HP 22</p>
	<p>76 047</p> 	<p>5 X 56 000 021</p> <ul style="list-style-type: none"> <li>- Hülse für Pumpenprüfung</li> <li>- Douille pour contrôle de la libre rotation de la pompe</li> <li>- Sleeve to check easy in rotation of pump gears.</li> </ul>	<p>identisch</p> <p>identique</p> <p>identical to 3 HP 22</p>
	<p>82 176</p> 	<p>5 X 46 000 170</p> <ul style="list-style-type: none"> <li>- Ausziehgriff für Dichthülsen</li> <li>- Poignée de démontage des joints d'alimentation d'embrayage</li> <li>- Puller for removal of sealing bushings.</li> </ul>	

**Spezialwerkzeuge 4 HP 22**  
**Outils spéciaux 4 HP 22**  
**Special Tools 4 HP 22**

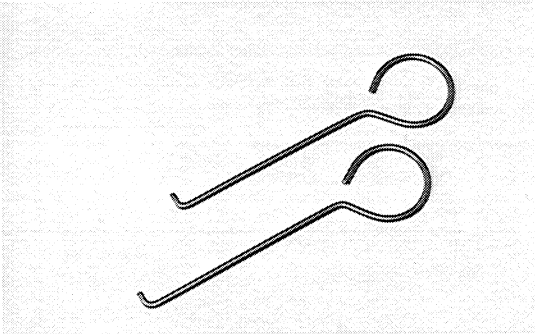
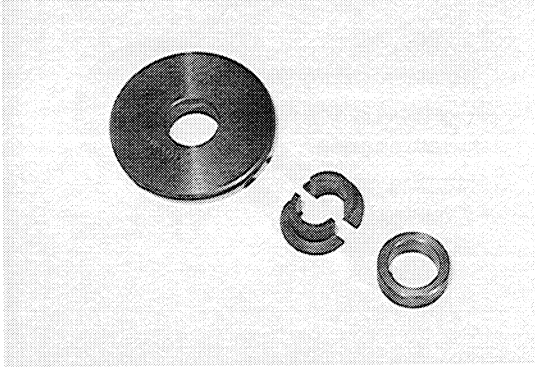
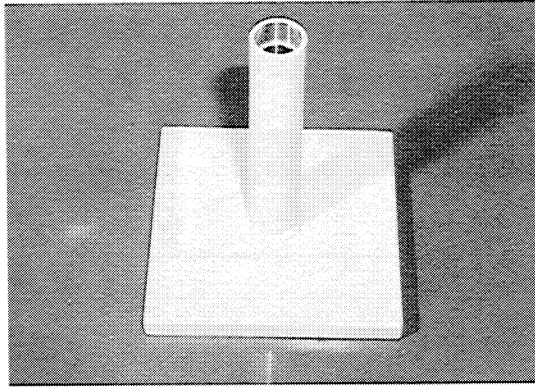
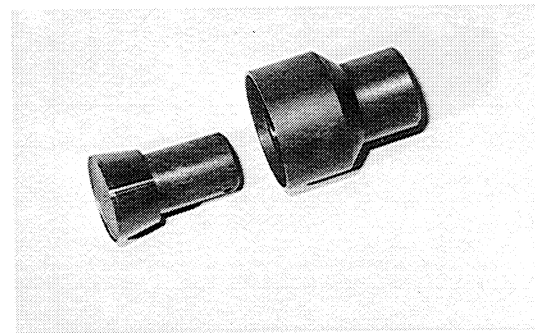
Bild Nr. Photo No Picture	GEGENSTAND OUTIL TOOL	Bestell-Nr. / Verwendungszweck No de commande / Application Part No / Application	Bemerkungen Observations Remarks
76 045		5 X 56 000 095 - Ausziehhaken 2 (St.) für Zylinder B kpl. - Poignées de dépose (2) du cylindre B complet - Puller hooks (2) for pulling of cylinder B assembly	identisch identique identical to 3 HP 22
76 037		5 X 56 000 094 - Haltevorrichtung für Abtrieb kpl. - Outil pour la dépose/repose du bloc arrière complet - Work locating fixture for brake C', C and D assembly	identisch identique identical to 3 HP 22
76 050		5 X 56 000 072 - Aufnahmevorrichtung für Abtrieb kpl. - Support pour bloc arrière complet - Supporting device for brake C', C and D assembly, as well as 4.th gear assembly	identisch identique identical to 3 HP 22
76 041		5 X 56 000 092 - Montagehülse für Sprengring Tellerfeder Kupplung B - Douille de montage pour le circlips du diaphragme embrayage - Mounting sleeve to insert snapping onto plate spring	identisch identique identical to 3 HP 22

**Spezialwerkzeuge 4 HP 22**  
**Outils spéciaux 4 HP 22**  
**Special Tools 4 HP 22**

Bild Nr. Photo No Picture	GEGENSTAND OUTIL TOOL	Bestell-Nr. / Verwendungszweck No de commande / Application Part No / Application	Bemerkungen Observations Remarks
76 048		<p>5 x 56 000 075</p> <ul style="list-style-type: none"> <li>- Montagehülse für O-Ring und Sprengring Sonnenradwelle</li> <li>- Douille de montage pour le joint torique et le cir-clips de l'arbre planétaire</li> <li>- Mounting sleeve to install o-ring and snap ring into sun shaft seat</li> </ul>	<p>identisch identique identical to 3 HP 22</p>
76 043		<p>5 X 56 000 093</p> <ul style="list-style-type: none"> <li>- Vorrichtung zum Drücken der Tellerfeder B-C-C'-D</li> <li>- Dispositif pour comprimer les diaphragmes B-C-C'-D</li> <li>- Device to press plate springs B-C-C'-D downward</li> </ul>	<p>identisch identique identical to 3 HP 22</p>
76049		<p>5 X 56 000 058</p> <ul style="list-style-type: none"> <li>- Montagehülse für Sprengring Tellerfeder D</li> <li>- Douille pour le montage du circlips du diaphragme D</li> <li>- Mounting sleeve for snap ring plate spring D</li> </ul>	<p>identisch identique identical to 3 HP 22</p>
82 177		<p>5 X 46 000 174</p> <ul style="list-style-type: none"> <li>- Montagehülse für Turm 4. Gang</li> <li>- Douille de montage pour parts 4ième vitesse</li> <li>- Mounting sleeve for 4th gear assembly</li> </ul>	

Spezialwerkzeuge 4 HP 22  
 Outils spéciaux 4 HP 22  
 Special Tools 4 HP 22

Bild Nr. Photo No Picture	GEGENSTAND OUTIL TOOL	Bestell-Nr. / Verwendungszweck No de commande / Application Part No / Application	Bemerkungen Observations Remarks
	<p>82 184</p> 	<p>5 P 89 001 673</p> <ul style="list-style-type: none"> <li>- Einstellehre für Steuergerät 11,5 mm breit</li> <li>- Pige de réglage du bloc hydraulique cote 11,5 mm</li> <li>- Tool for valve body adjustment head size 11,5 mm.</li> </ul>	
	<p>77 034</p> 	<p>5 X 30 000 031</p> <ul style="list-style-type: none"> <li>- Verstemmhülse für Sicherungsblech Abtriebsflansch</li> <li>- Douille pour le sertissage de la tôle - frein de la bride de sortie-boîte</li> <li>- Penning tool for securing plate on output flange</li> </ul>	<p>identisch</p> <p>identique</p> <p>identical to 3 HP 22</p>
	<p>78 085</p> 	<p>5 X 46 000 069</p> <ul style="list-style-type: none"> <li>- Montagehülse für Wellendichtring</li> <li>- Douille de montage pour le joint à lèvres</li> <li>- Mounting sleeve for shaft sealing ring</li> </ul>	<p>identisch</p> <p>identique</p> <p>identical to 3 HP 22</p>

Spezialwerkzeuge 4 HP 22  
 Outils spéciaux 4 HP 22  
 Special Tools 4 HP 22

Bild Nr. Photo No Picture	GEGENSTAND OUTIL TOOL	Bestell-Nr. / Verwendungszweck No de commande / Application Part No / Application	Bemerkungen Observations Remarks
82 179		5 X 46 000 167 - Montagehilfe für Tellerfeder E+F - Outil de montage pour diaphragme E+F - Mounting support tools for spring plate E+F	
82 180		5 x 46 000 169 - Montagering für Freilauf - Douille de montage pour roue libre - Split rings for assembly of freewheel cage	
82 181		5 x 46 000 139 - Fügwerkzeug für Sprengring - Outil de montage pour circlips - Mounting tool for snap ring	

Spezialwerkzeuge 4 HP 22  
 Outils spéciaux 4 HP 22  
 Special Tools 4 HP 22

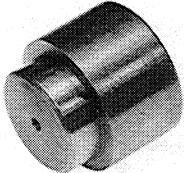
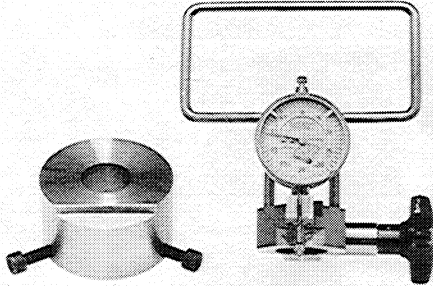
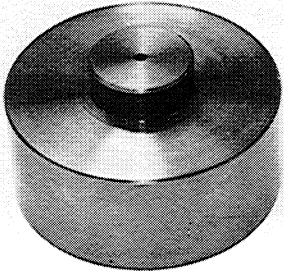
Bild Nr. Photo No Picture	GEGENSTAND OUTIL TOOL	Bestell-Nr. / Verwendungszweck No de commande / Application Part No / Application	Bemerkungen Observations Remarks
	<p>82 181</p> 	<p>5 x 46 000 175</p> <ul style="list-style-type: none"> <li>- Einpressdorn für Nadellager</li> <li>- Tampon pour l'emmanchement du roulement à aiguilles</li> <li>- Insertion mandrel for needle bearing</li> </ul>	
	<p>82 183</p> 	<p>5 P 01 001 415</p> <ul style="list-style-type: none"> <li>- Meßgerät für Axialspiel</li> <li>- Dispositif pour mesure de jeu axial</li> <li>- Gauge for internal axial clearance of transmission</li> </ul>	
	<p>82 178</p> 	<p>5 X 46 000 168</p> <ul style="list-style-type: none"> <li>- Montageauflage für Abtrieb</li> <li>- Support pour montage de l'ensemble sortie-boîte</li> <li>- Mounting support for 4th gear assembly</li> </ul>	

**Spezialwerkzeuge 4 HP 22**

**Outils spéciaux 4 HP 22**

**Special Tools 4 HP 22**

Bild Nr. Photo No Picture	GEGENSTAND OUTIL TOOL	Bestell-Nr. / Verwendungszweck No de commande / Application Part No / Application	Bemerkungen Observations Remarks



## 2. Disassembling

### 2.1 Disassembling after sequence

82 002

Clamping device 5 X 56 000 096 for transmission assembly and disassembly. Removal of convertor use special mounting tool 5 X 56 000 090 as shown on the picture.

**Attention:** Oil running out.  
Handle carefully, do not damage pump bush and lip of sealring.

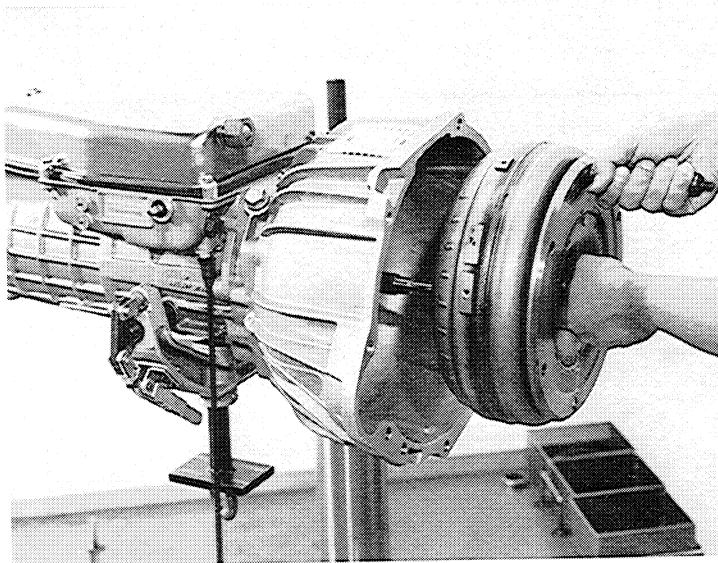

82 003

Unscrew bolts on oilpan to remove oilpan

Screw head size 10 mm

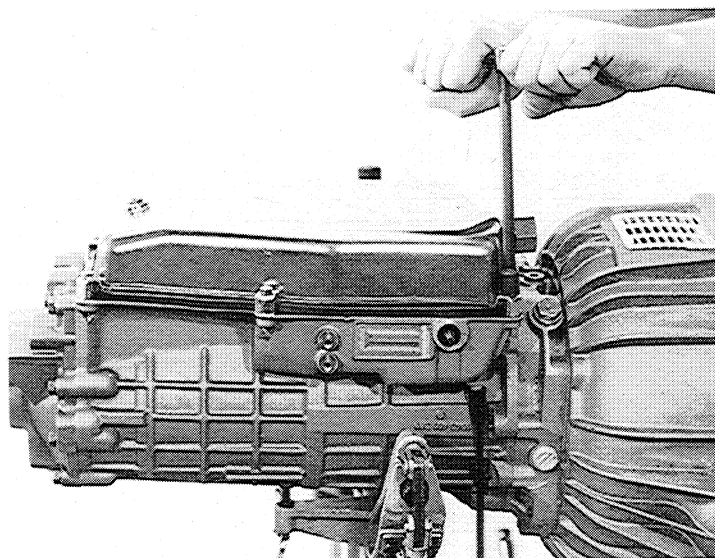

82 004

Unscrew three torx head bolts to remove oil screen.

Use Torx bit 27

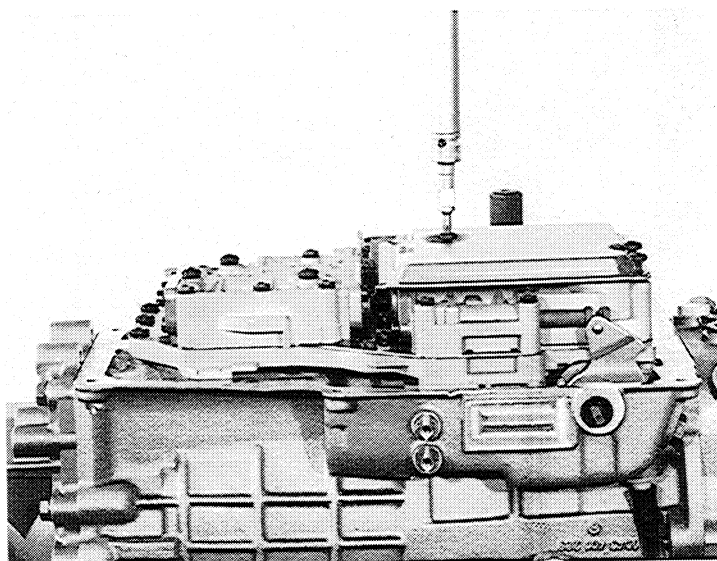

Unscrew valve body connecting bolts (large head only) to remove valve body assembly.

Use torx bit 27

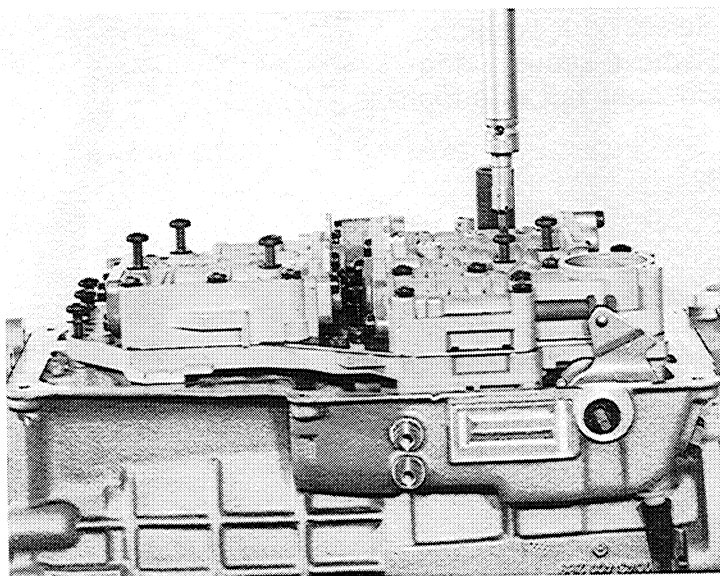

82 006

Remove 8 circlips and springs

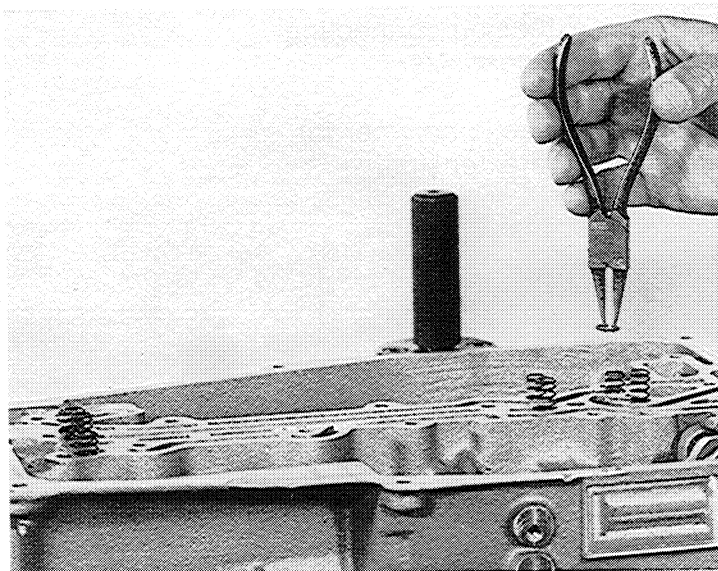

82 007

With puller (5 X 46 000 170) screw in and pull out 8 sealing rubbers

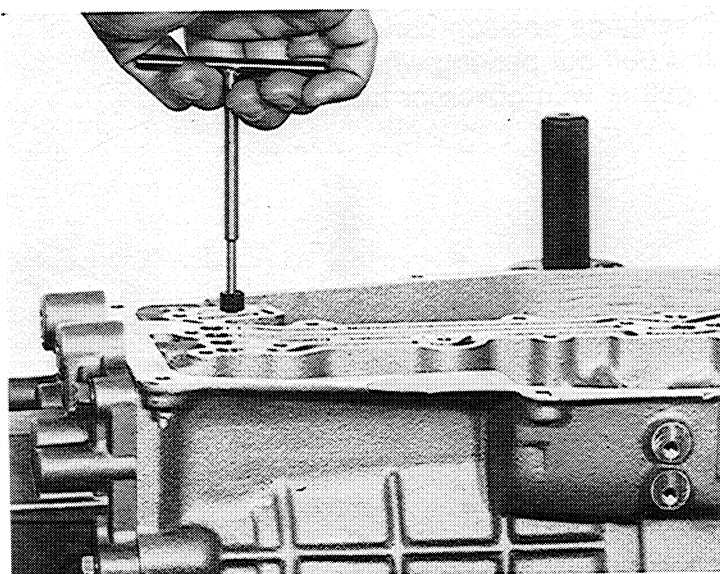

Select park position  
 Remove security ring  
 Unscrew nut with toolsize  
 32mm

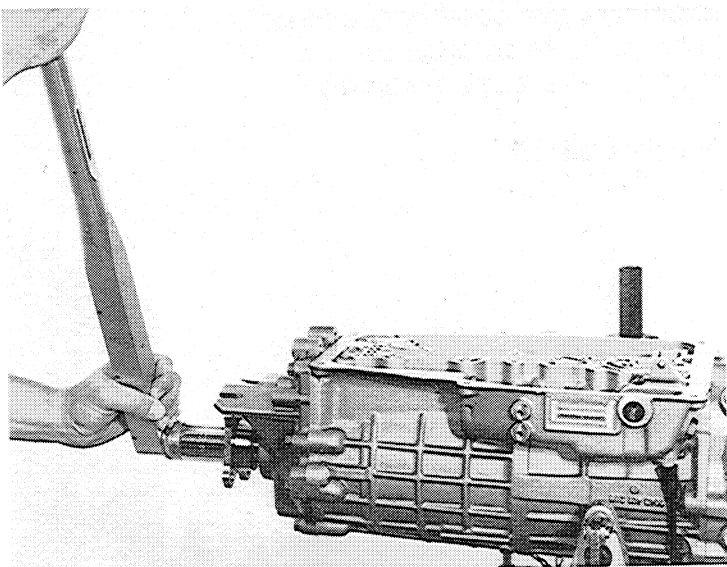

Unscrew extension connecting  
 bolts (13mm headsize)

Use only a plastic hammer for  
 loosening the extension

Remove gasket

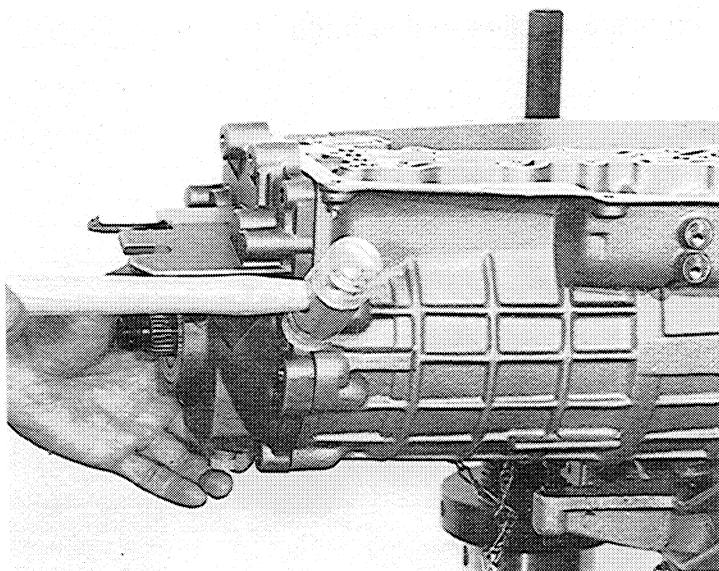

Disengage position park  
 and pull out parking wheel  
 together with governor hub

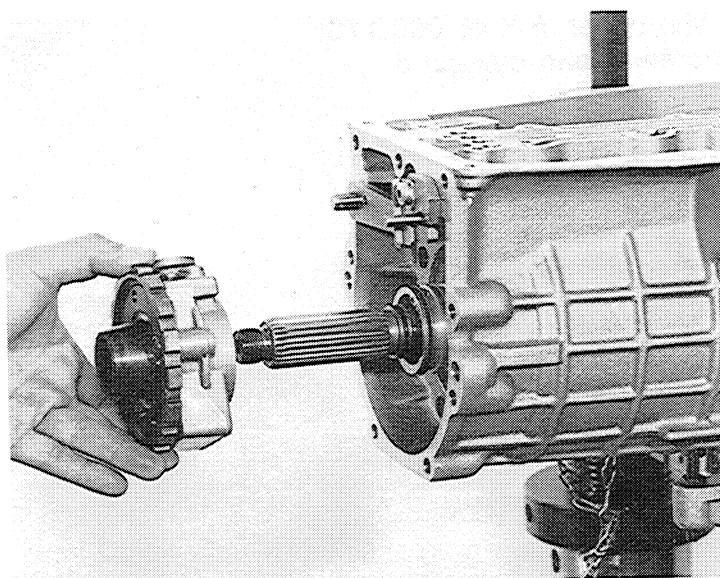

Unscrew connection bolt on  
guide plate for removal.  
Use Torx bit 27.

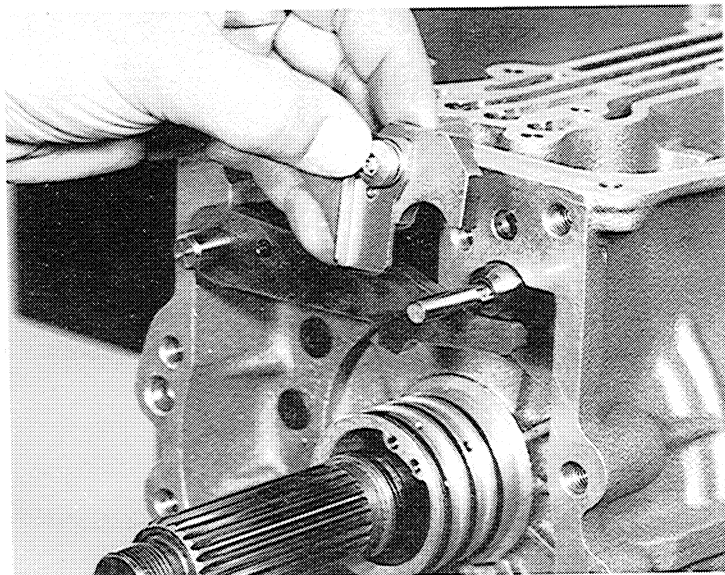

Remove pin, pawl, and leg  
spring.

**Attention:** Spring tension  
reduced upon removal of park  
assembly

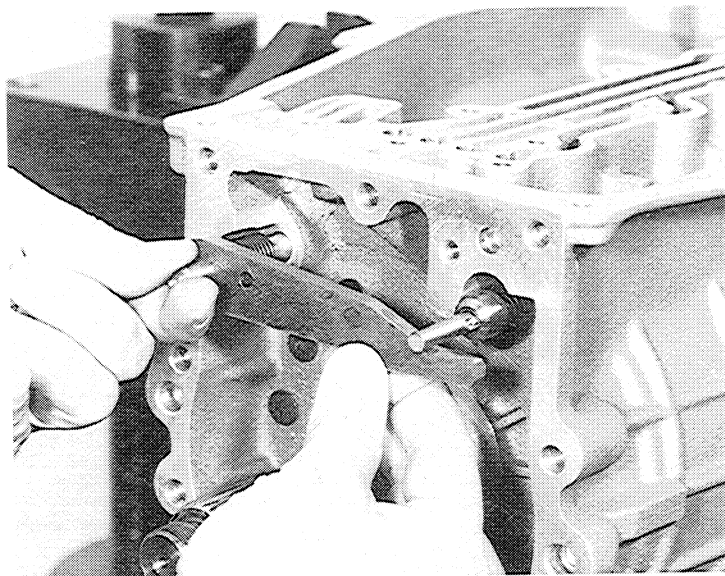

For simple removal of whole 4th  
gear assembly - use mounting  
tool (5 X 46 000 174) with  
locking nut.

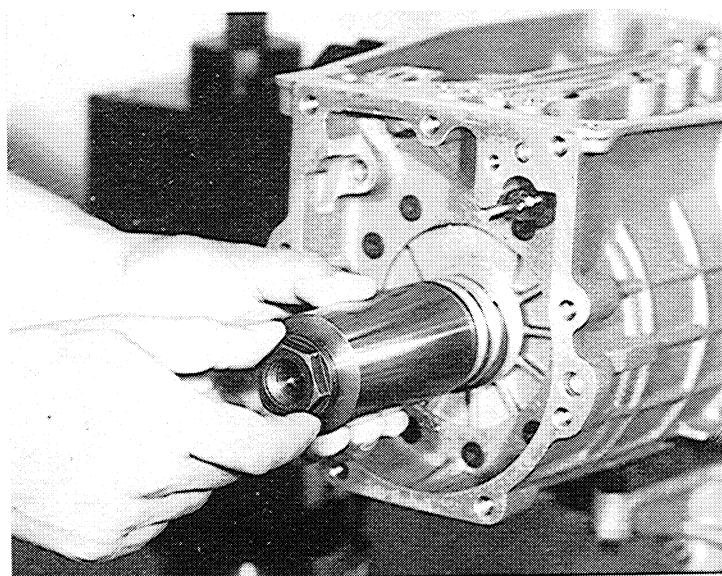



Unscrew 10 connection bolts of cylinder "F".

**Attention:** Use torx bit 30

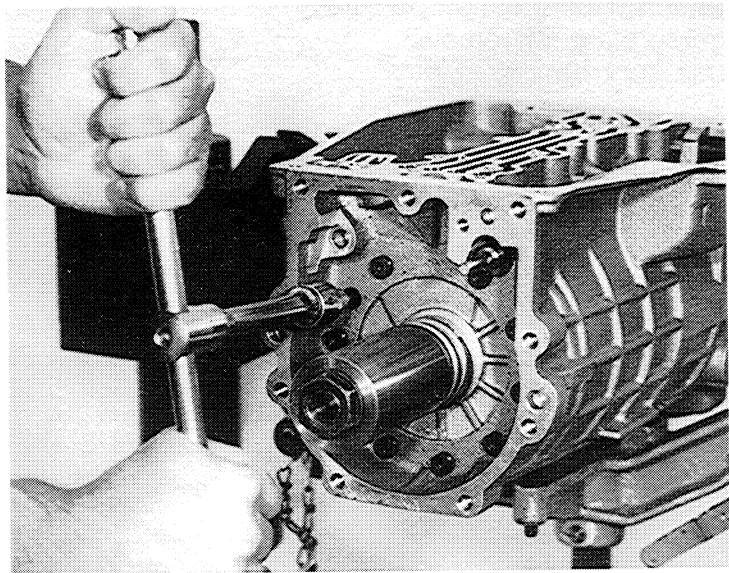

82 013

Removal of bellhousing and intermediate plate. Due to normal work procedure, unscrew only 12 hexagon connecting bolts on the inside diameter bolt pattern.  
Tool headsize 17 mm.

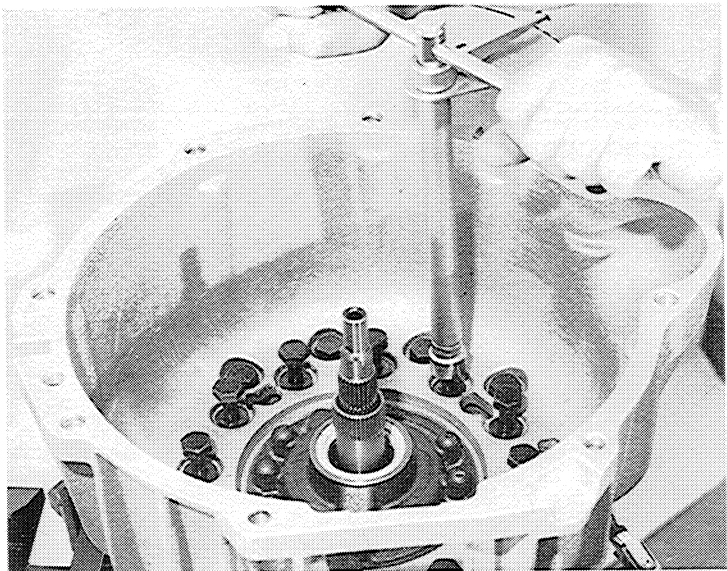

82 014

If it is necessary to remove bell housing due to damage, unscrew 6 remaining bolts and disconnect bell housing from intermediate plate.

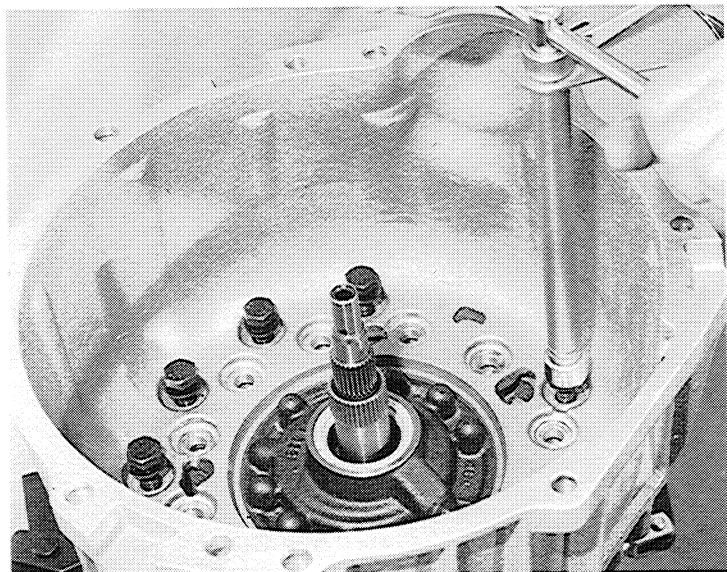

Remove input shaft together with clutch "A" assembly.

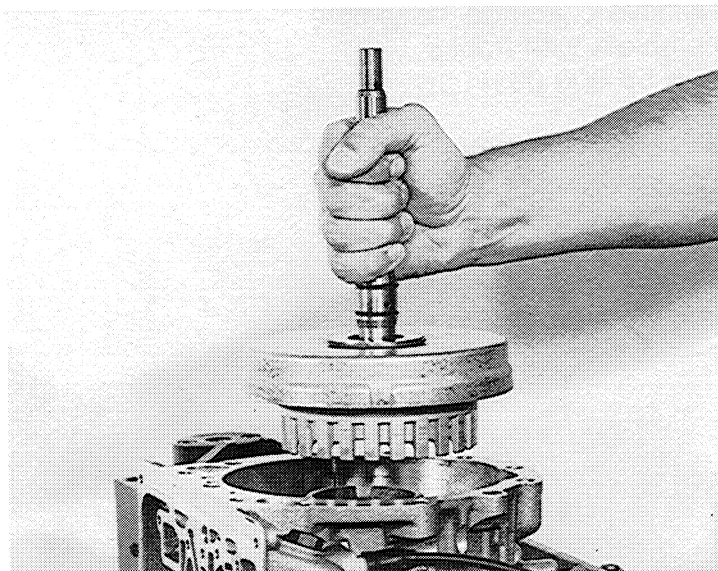

Remove inner carrier "A" from seat of intermediate shaft.

Remove also disc, axle bearing, and thrust washer.

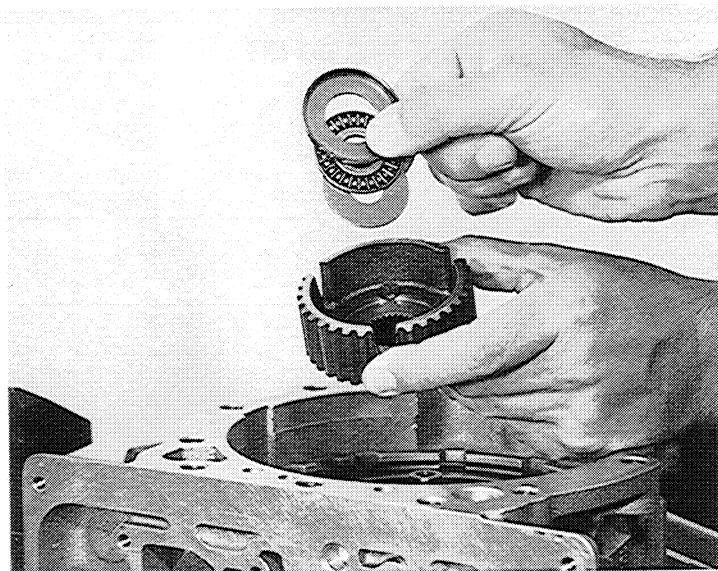

Remove small snapping in cylinder „B”, use 2 screwdrivers as shown on the picture.

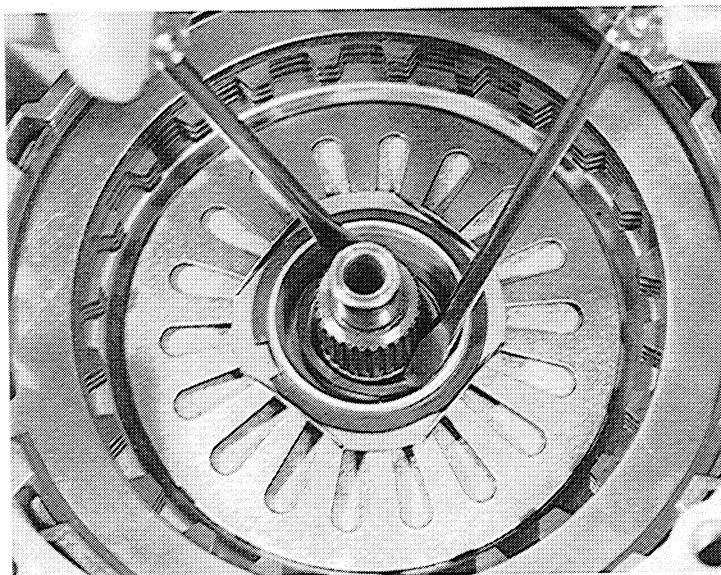

Remove clutch "B" assembly  
complete with hooks  
(5 X 56 000 095)

**Attention:** Work Procedure:  
Lift up cylinder "B" to stop  
point, push it back down, lift  
up again with more strength.  
After removal of cylinder "B"  
remove supporting ring as well as  
o-ring.

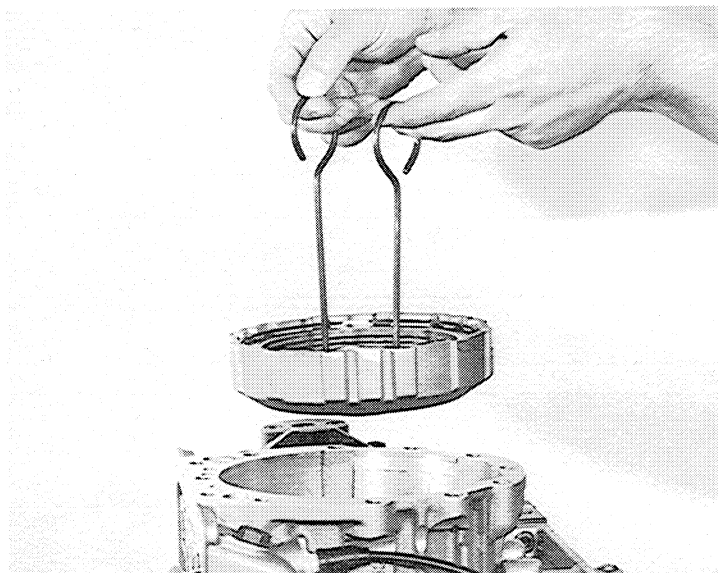

Remove snapping of centerplate  
with screwdriver as shown on the  
picture.

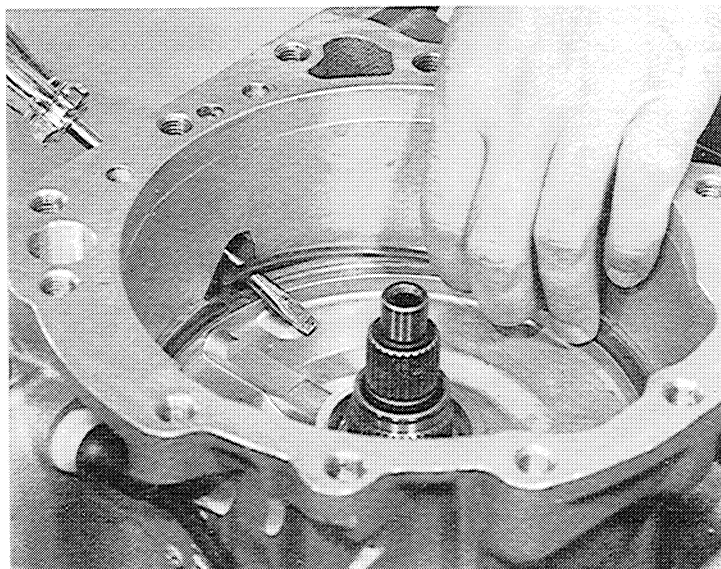

Attach mounting tool  
(5X 56 000 094) to intermediate  
shaft seat as shown on picture.

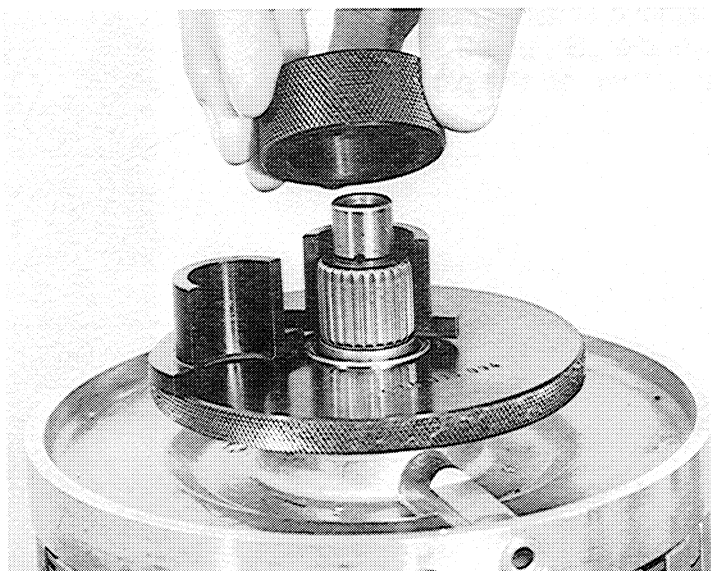

Remove C, C' and D clutch assembly out of transmission case.

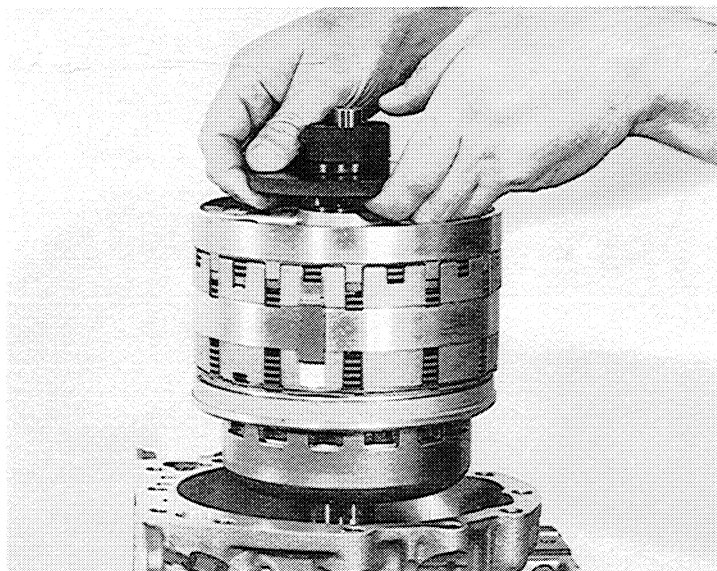

Remove disc, axle bearing, and thrust washer.

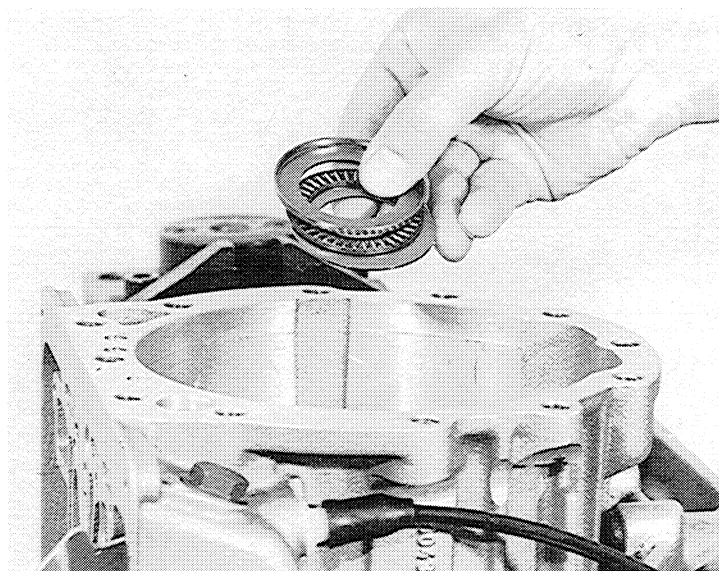

For removal of 4th gear assembly put transmission case in horizontal position.

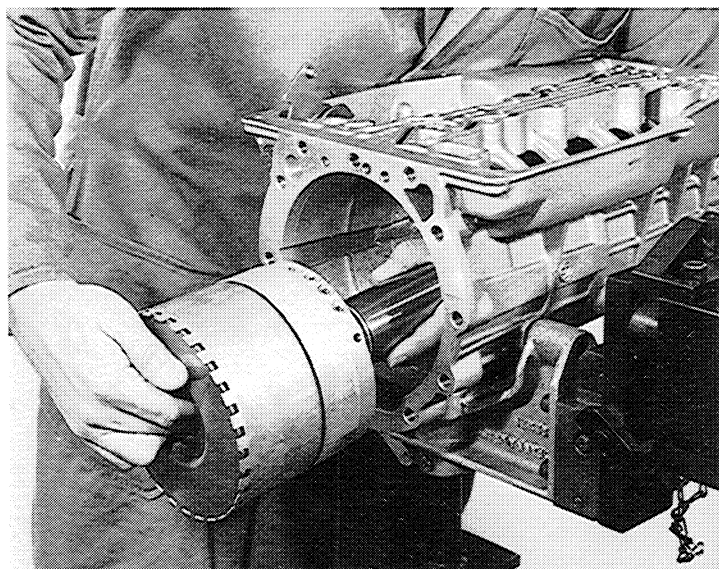



## 2.2 4th Gear Assembly

82 024

Remove mounting tool from output shaft. Place whole 4th gear assembly into supporting device (5 X 56 000 072)

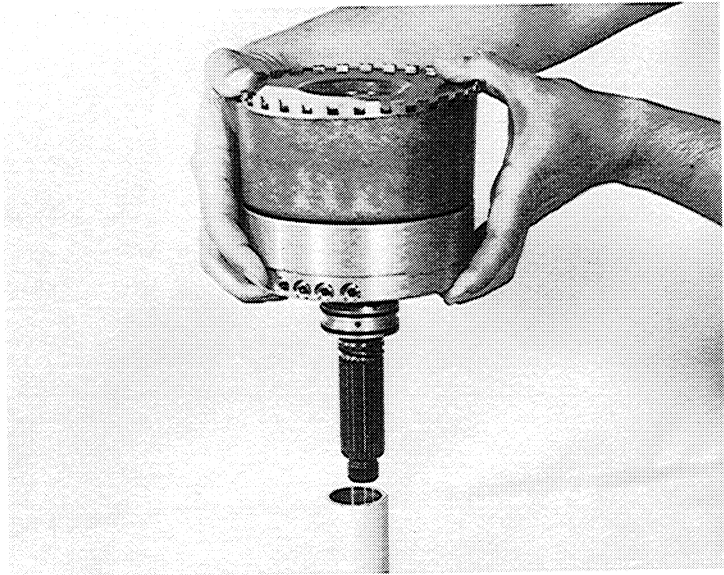

82 025

Remove sun gear

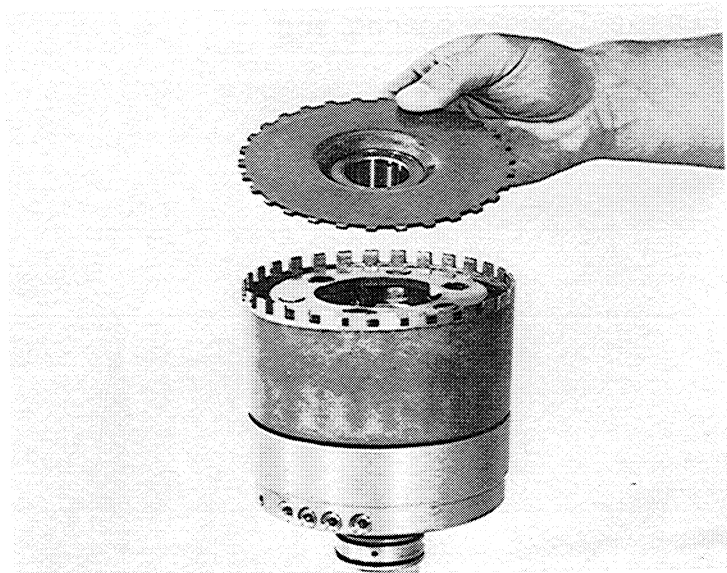

82 026

Remove planetary set  
Removal of snapping on planetary case not necessary

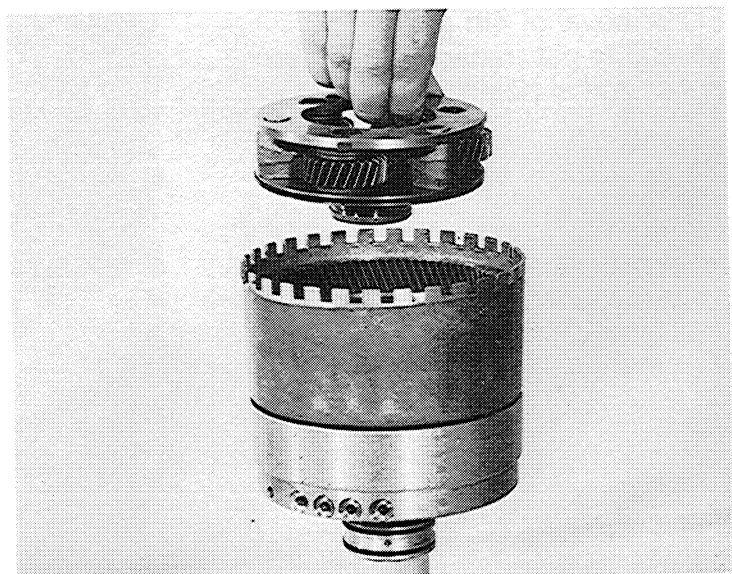

Remove disc, axle bearing and thrust washer

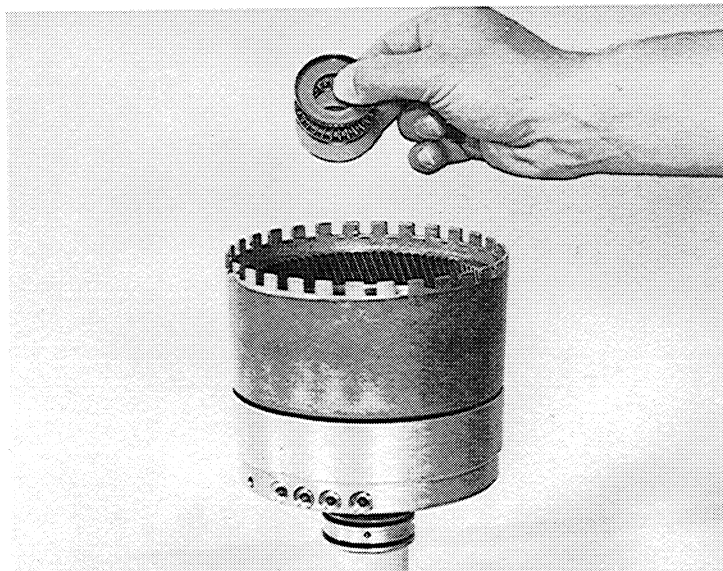

Turn 4th gear assembly upside-down onto special mounting tool (5 X 46 000 168)

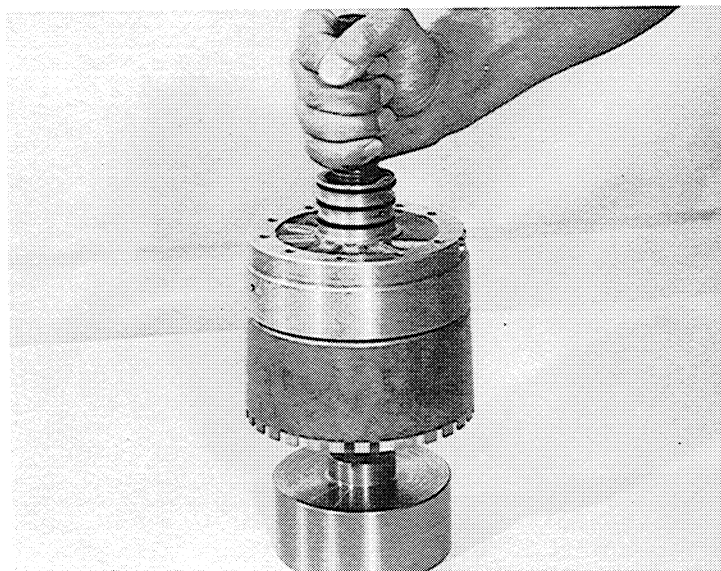

Separate cylinder F from cylinder E

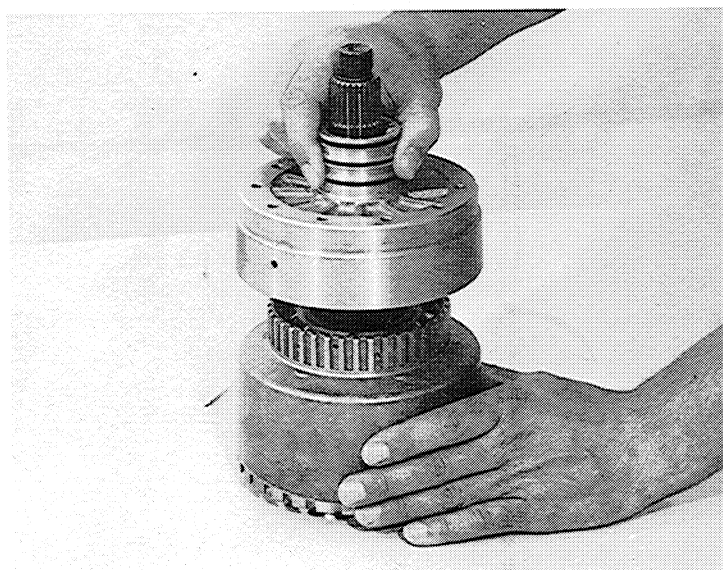

82 030

Remove cylinder E from  
freewheel 3rd

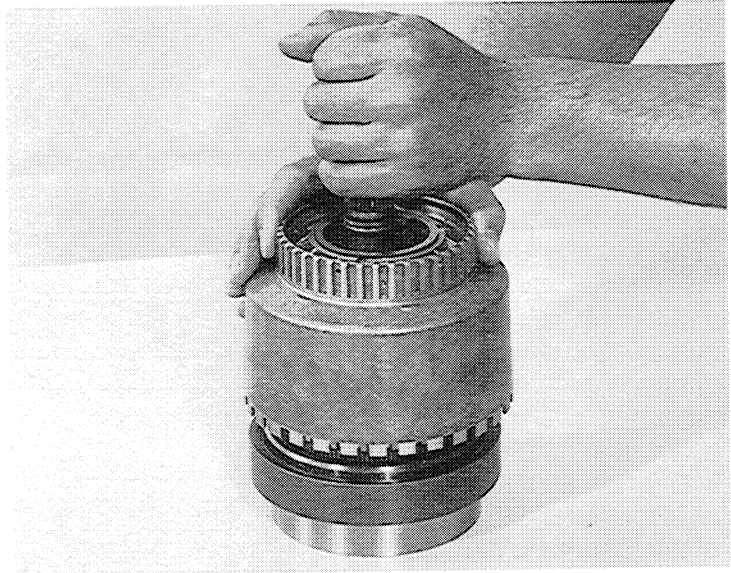

82 032

Remove axle disc and cage  
as well as 2 thrust washers

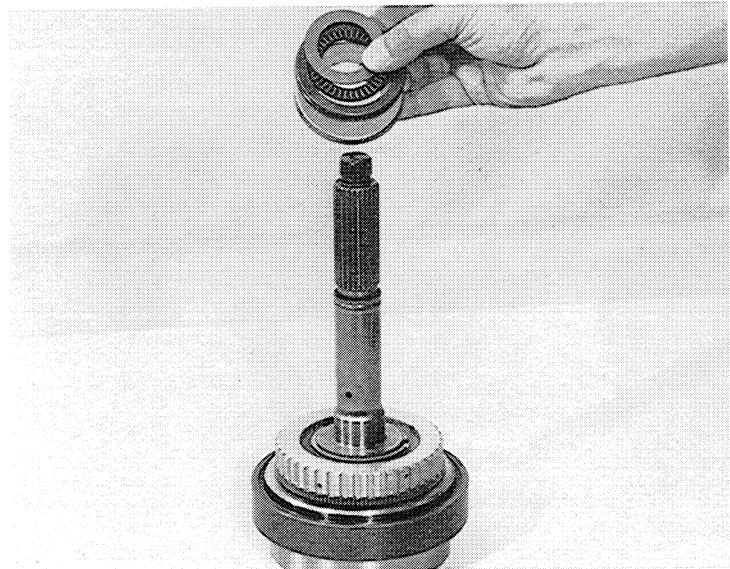

82 033

### 2.2.1 Output with Freewheel

To remove snapping on carrier  
E, use pliers and a screwdriver

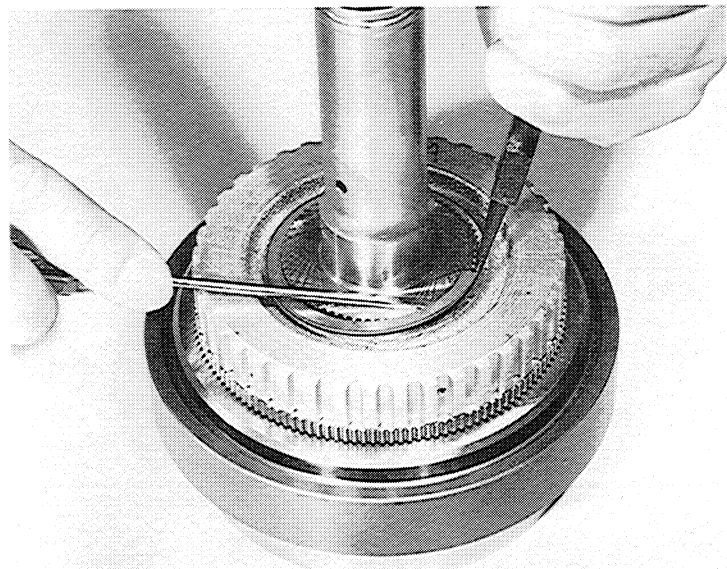

Remove output shaft from ring gear

Do not remove snap ring on output shaft

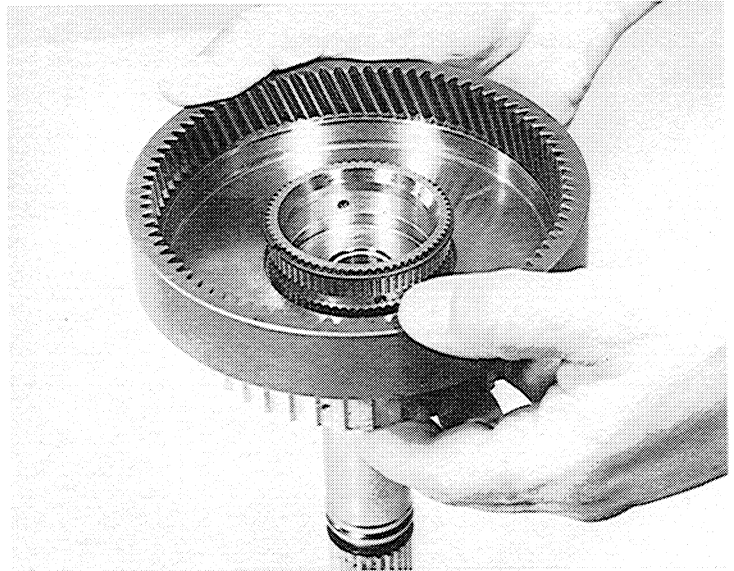

Remove carrier E

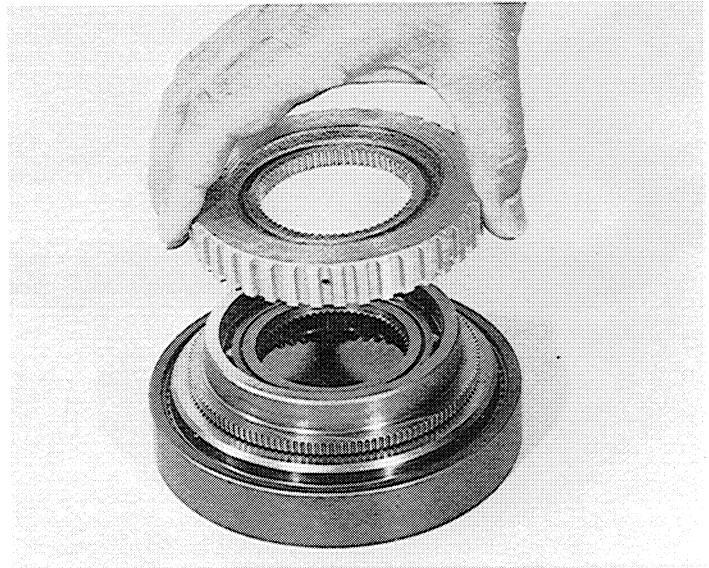

To remove freewheel cage use upward turning motion on freewheel outer ring

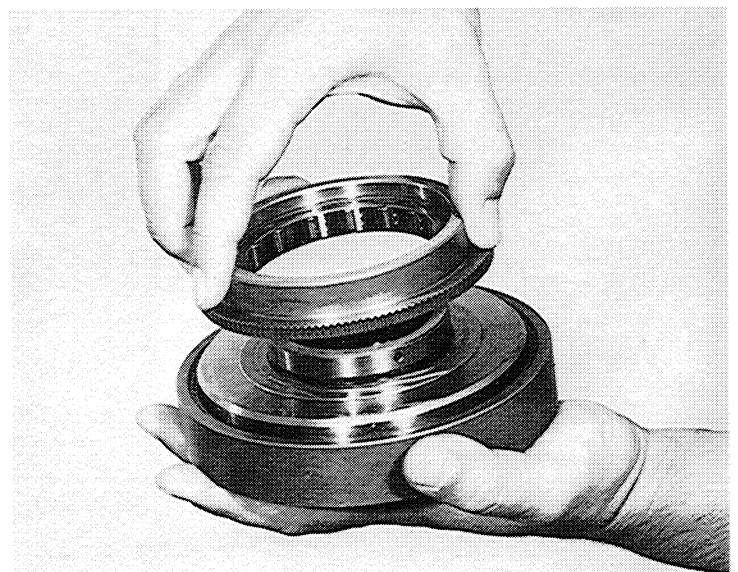



82 037

After removal of the snapping, disconnect freewheel inner ring from hollow gear



82 038

Remove freewheel cage carefully out of freewheel outer ring

**Attention!** Freewheel rollers may fall out during removal of cage

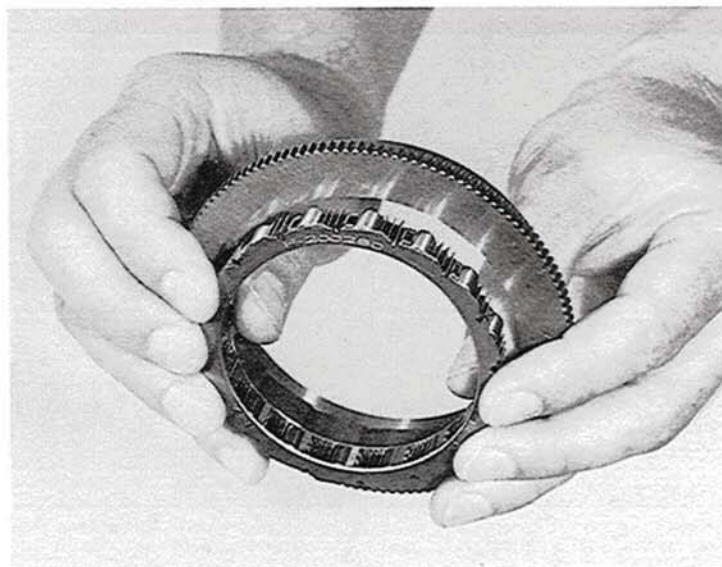

82039

## 2.2.2 Brake F

Remove snapping in clutch F

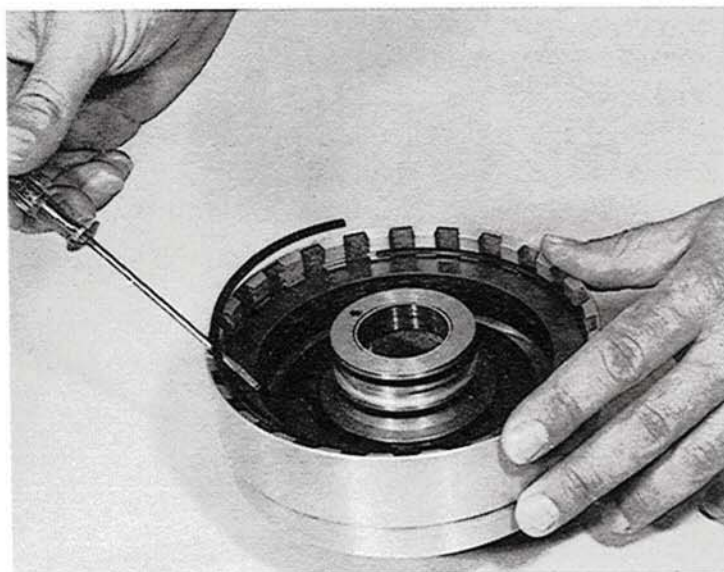

Remove clutch F  
assembly complete

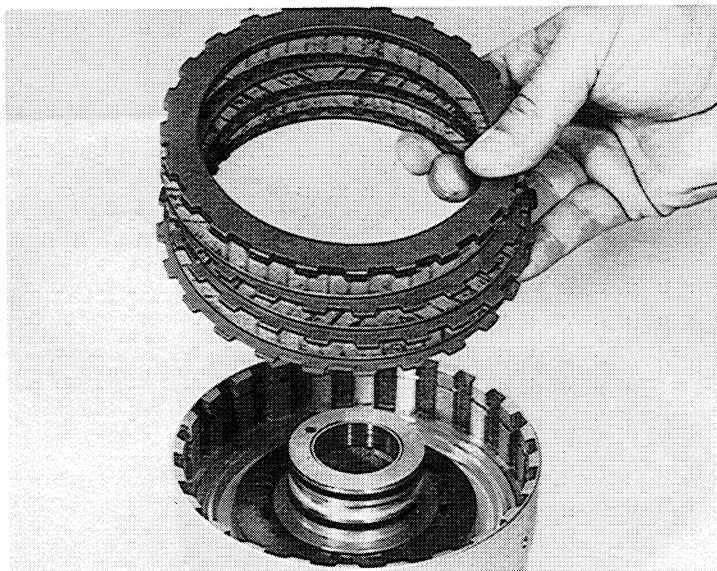

With mounting support  
(5 X 46 000 167) press  
down plate spring for removal of  
split rings

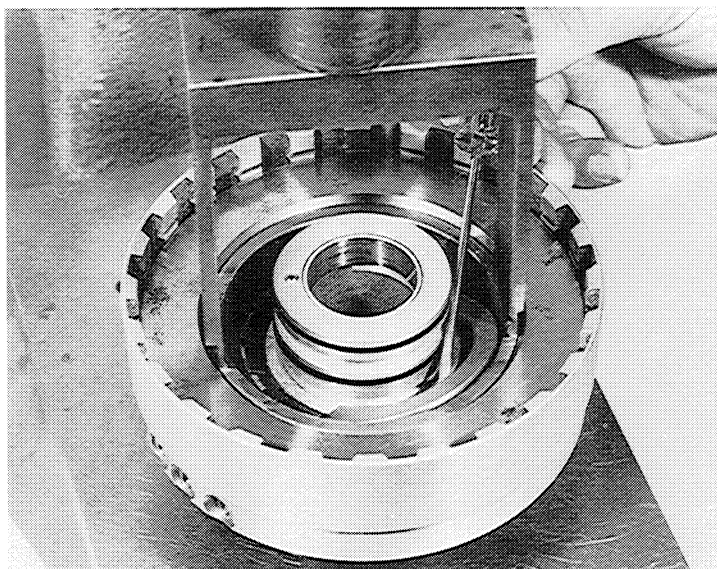

For removal of piston in  
cylinder F  
use two small punches

Under normal procedure do  
not remove the 5 sealing rings

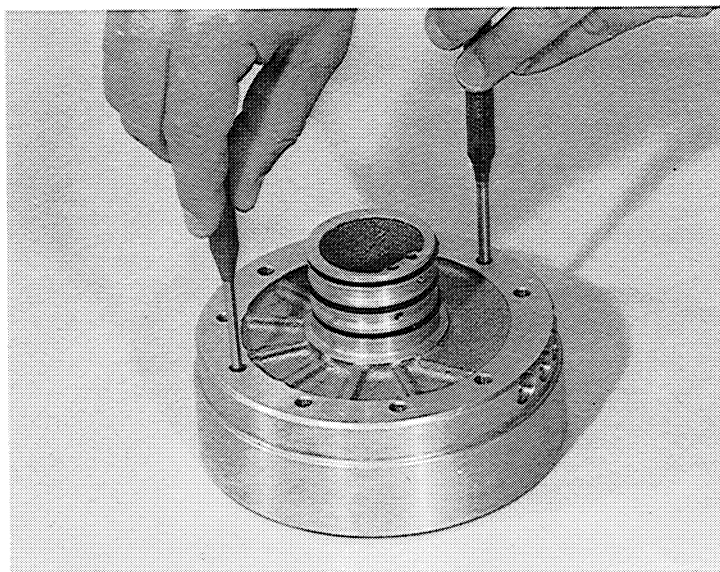

### 2.2.3 Clutch E

82 041

Remove snapping from clutch E.

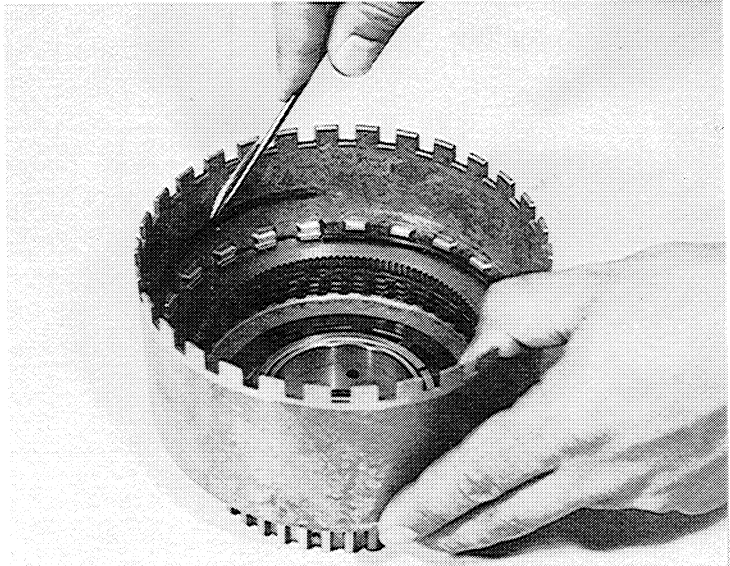

82 044

Remove clutch E assembly complete.

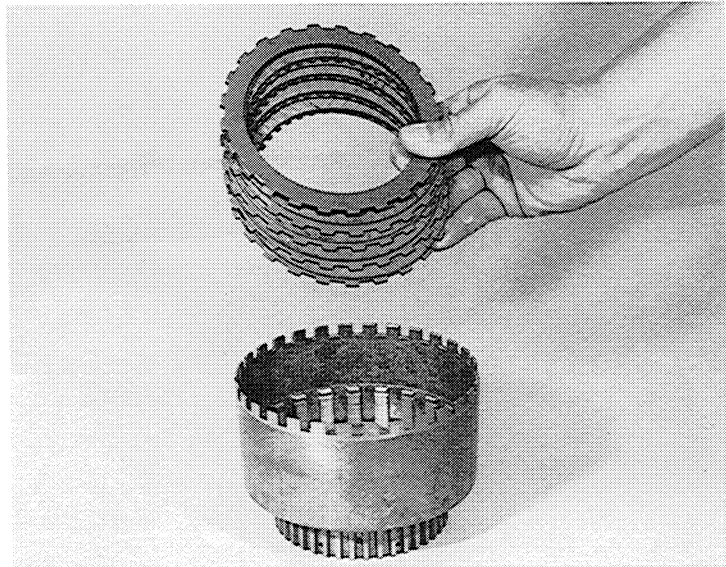

82 079

In the same manner as explained for brake F.

In addition, remove pressure plate.

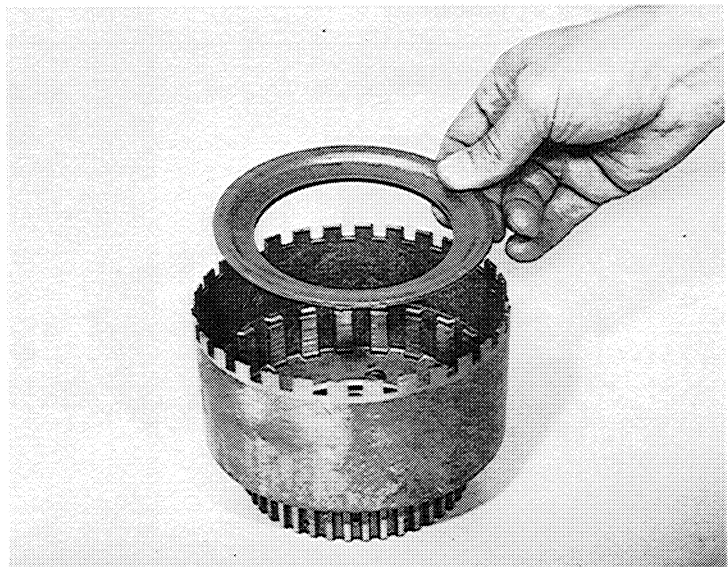



For easy removal of piston E, use air pressure from air gun.

Direct air into oil feed hole.

If carrier F has snapping, do not remove during normal work procedure.

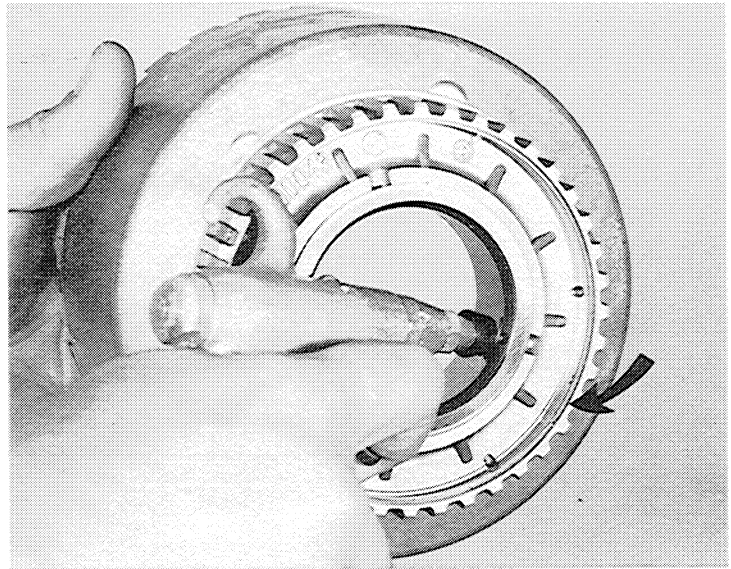

### 2.3 Planetary Set with Web Shaft and Brakes C', C and D

Remove center plate complete.

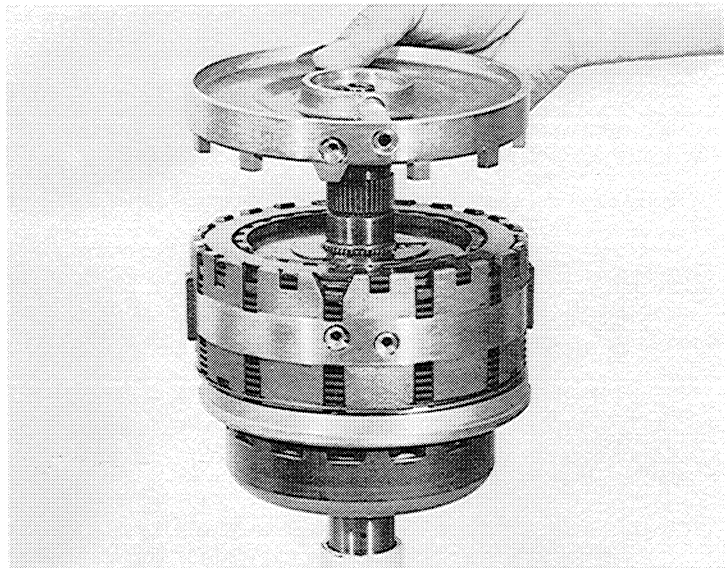

Remove brake C' assembly complete.

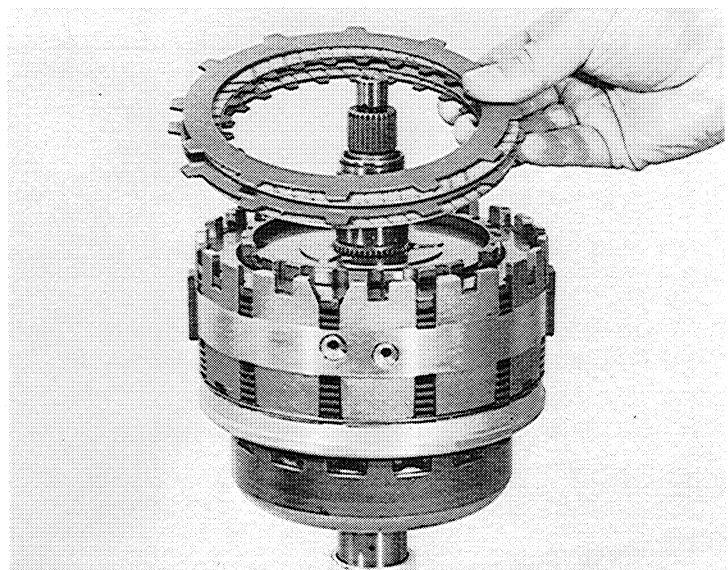



Remove freewheel 2nd complete.

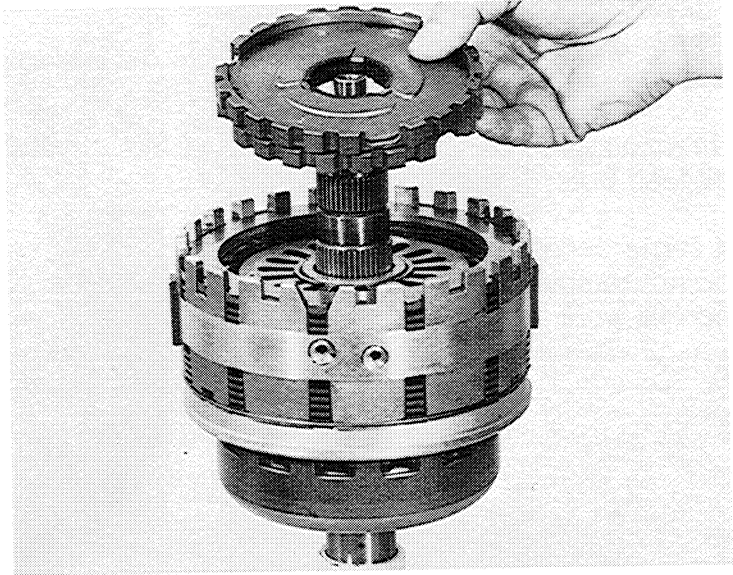

Remove brake C assembly complete.

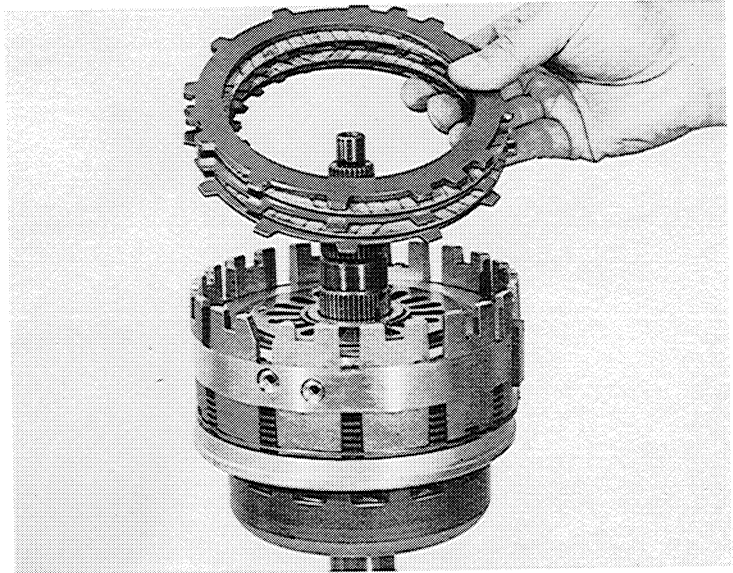

Remove cylinder C-D complete together with brake D assembly.

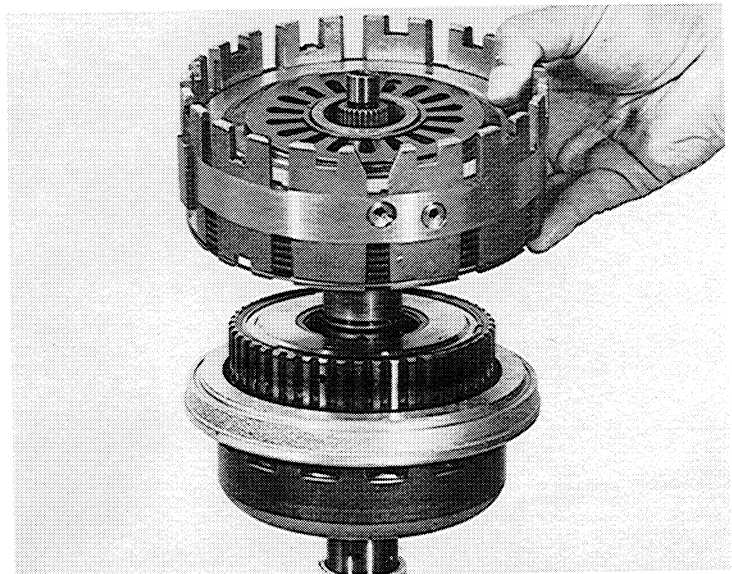

Remove support ring complete.

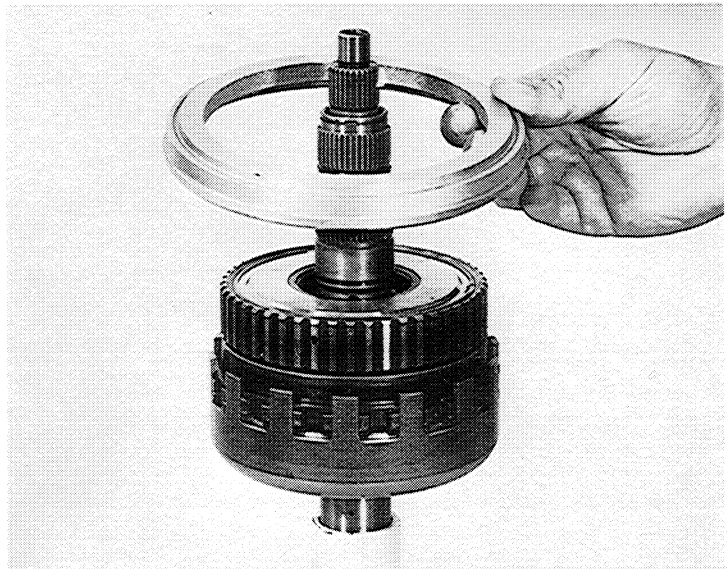

Remove front planetary set with freewheel complete.

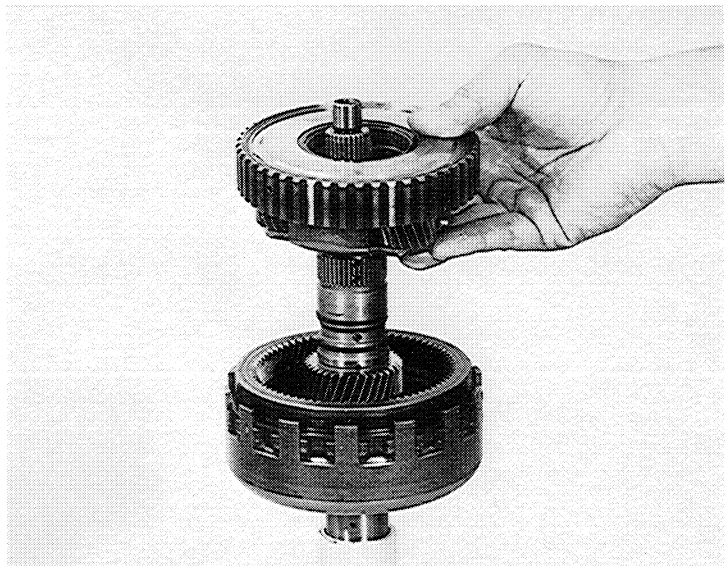

Remove sunshaft.

During normal work procedure do not remove seal rings on sunshaft.

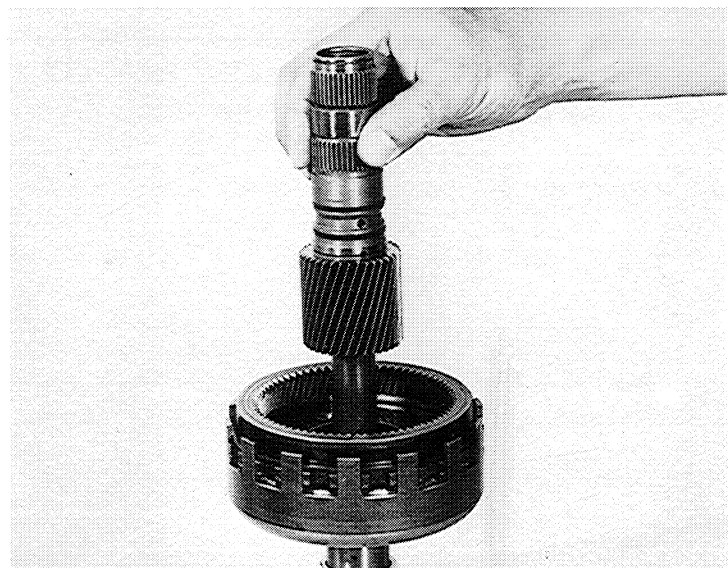

82 121

Remove snap ring  
from hollow gear.

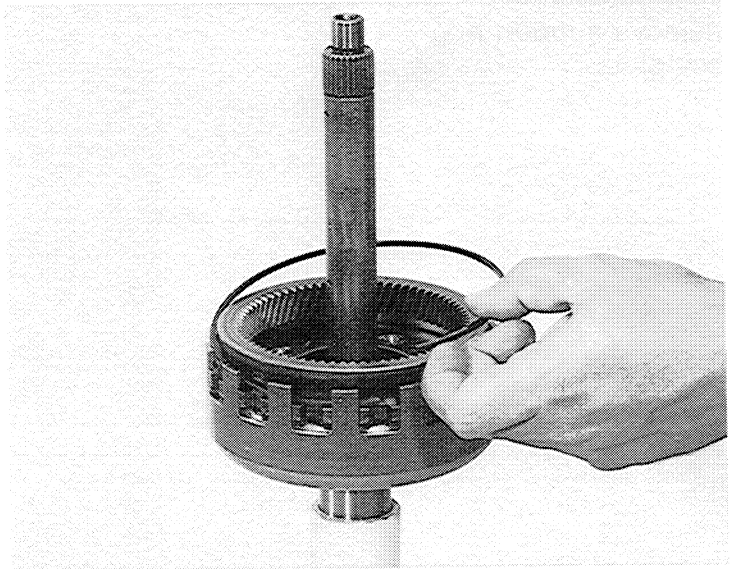

82 122

Remove hollow gear.

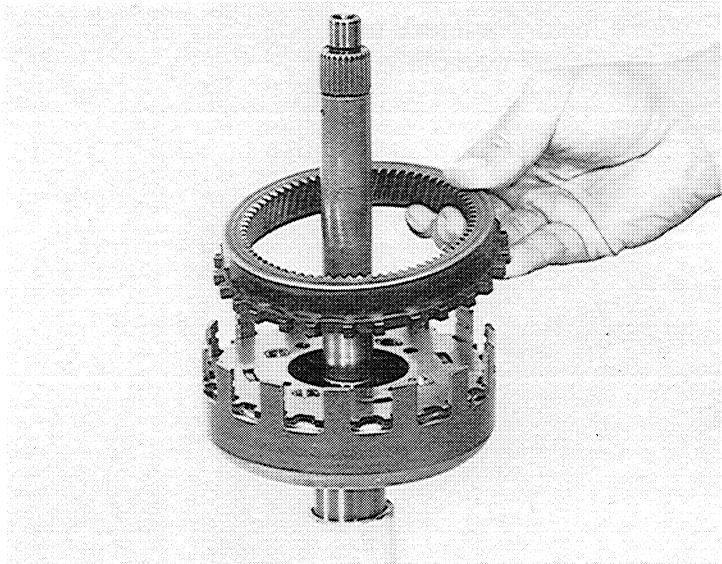

82 054

Remove rear planetary set  
complete.

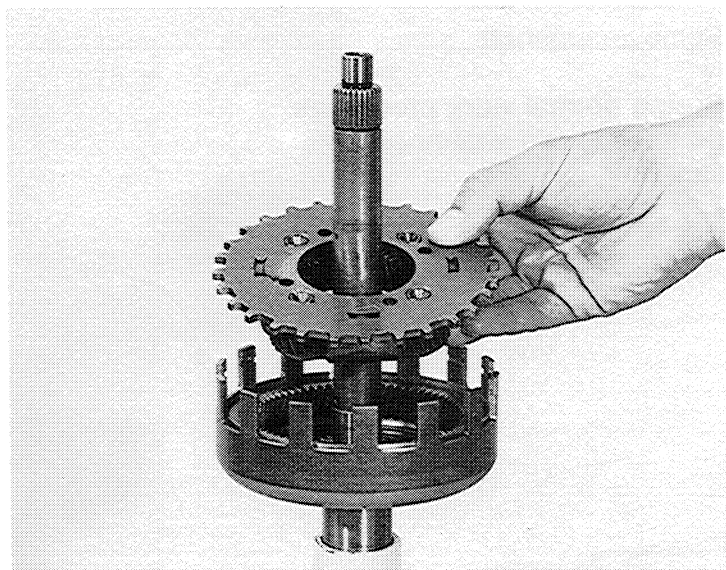

82 055

Remove thrust washer  
and axle bearing.

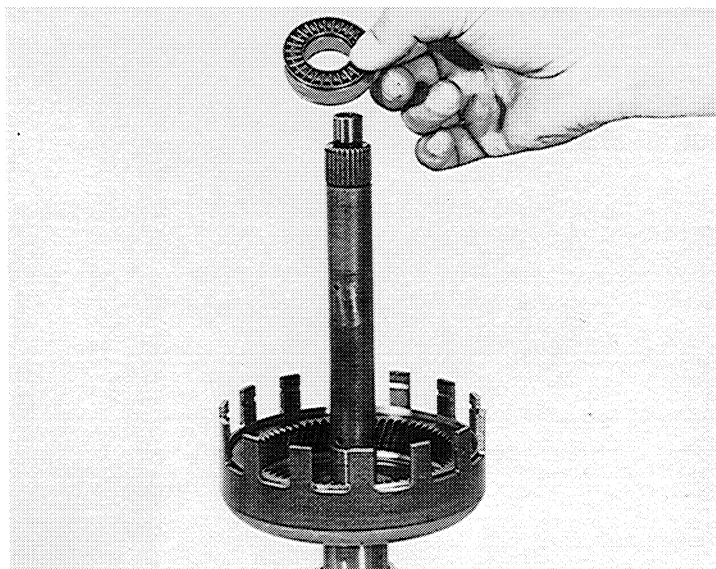

82 056

Remove intermediate shaft  
with hollow gear complete.

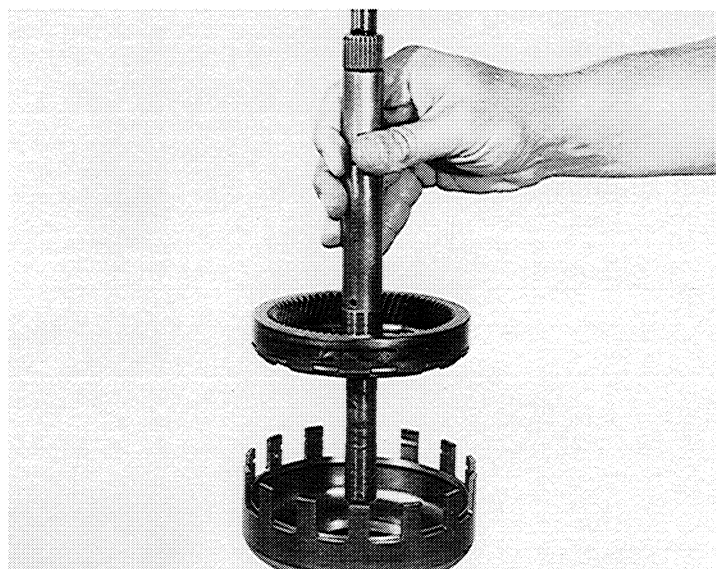

82 057

Remove axle bearing  
and 2 thrust washers.

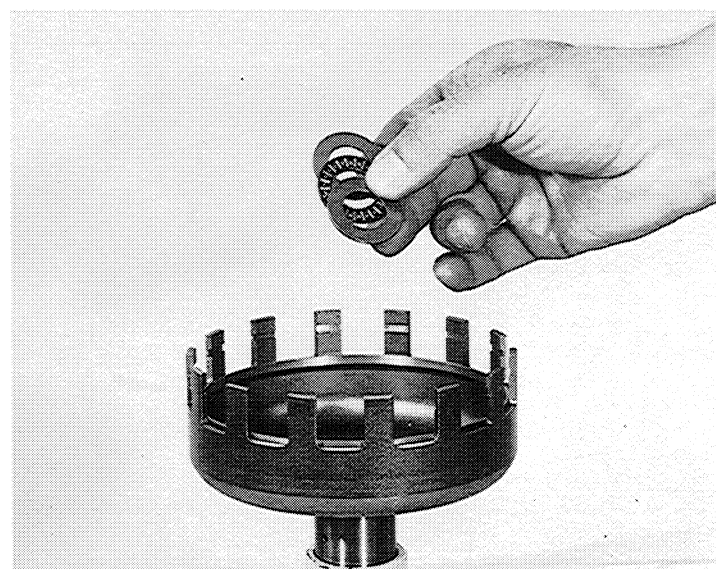



82 058

Remove distance ring.

Due to normal work procedure,  
do not remove snapping in  
output shaft.

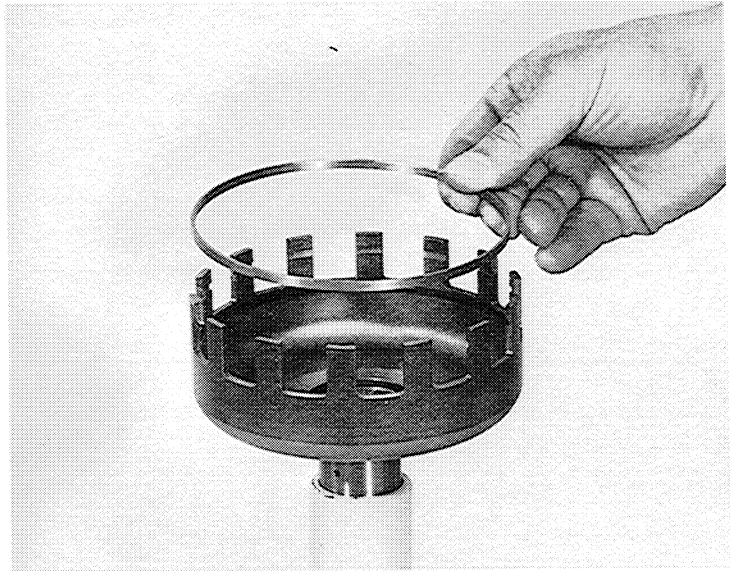

82 059

Remove snapping from rear  
hollow gear.

After removal of snapping,  
disconnect hollow gear  
from intermediate shaft.

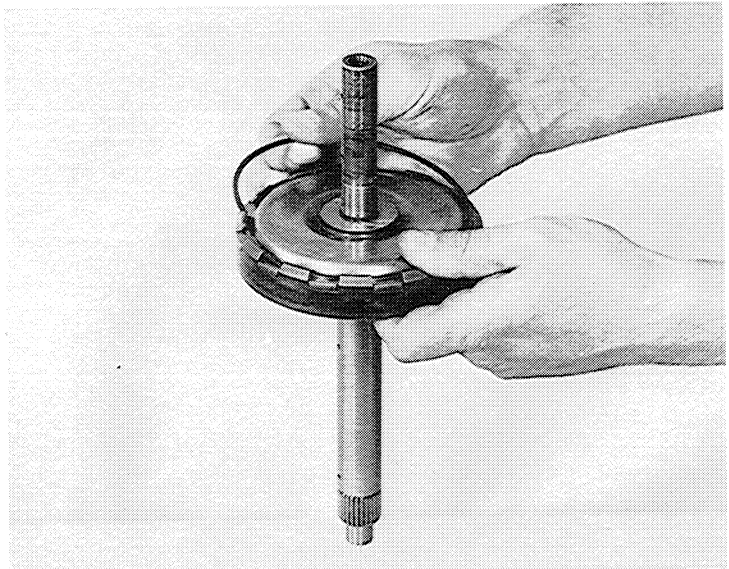

82 060

Remove outer snapping  
from brake (D) assembly.

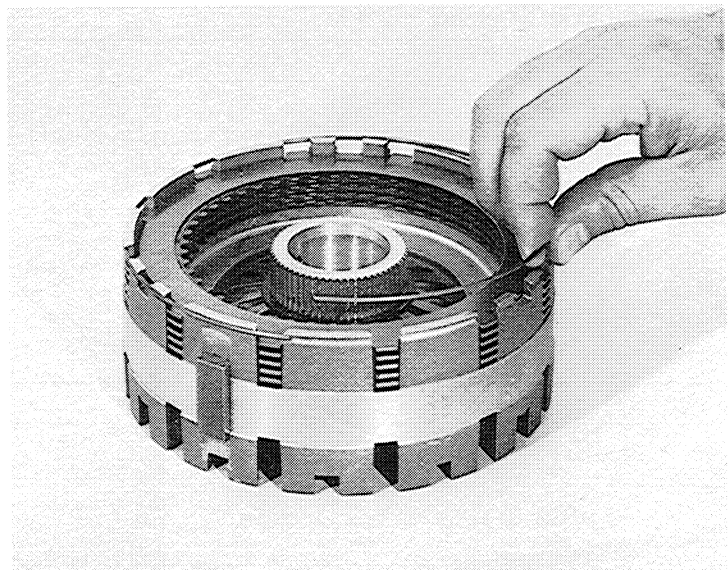

Remove brake D assembly complete.

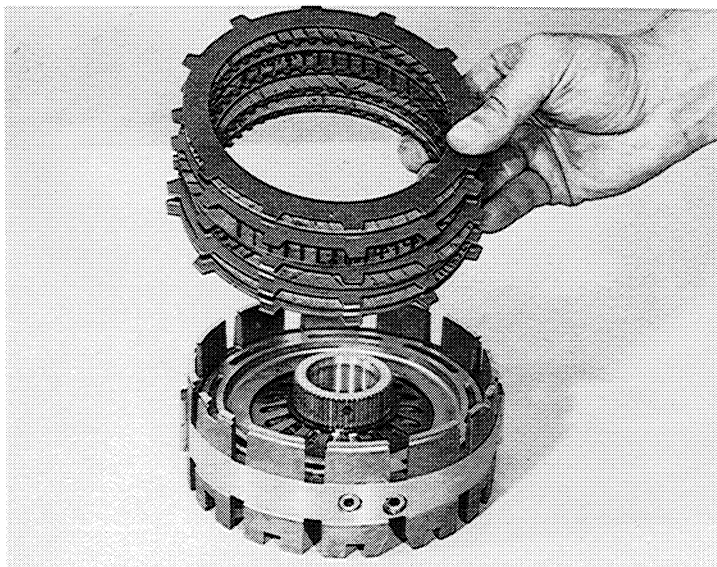

81 112

With spring device (5 X 56 000 093) press down plate spring C for removal of split rings.

Turn cylinder C-D upside-down; in the same manner remove plate spring D and snapping with pliers.

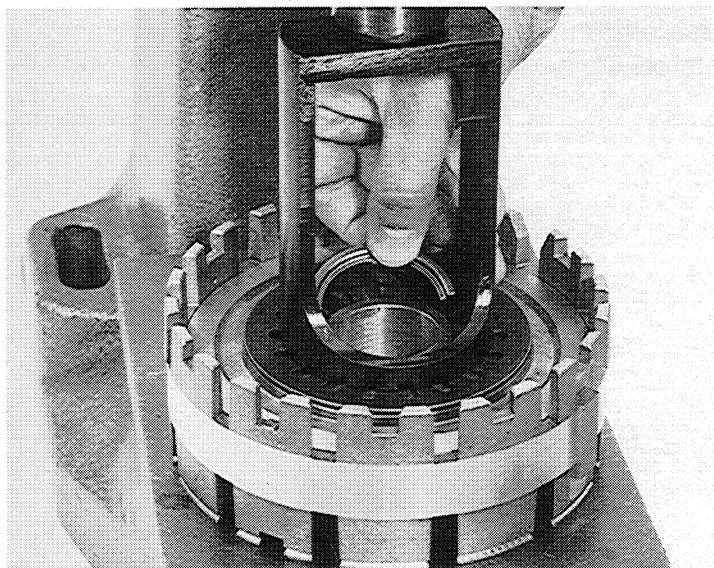

81 114

For easy removal of piston C and D, use air pressure in oil feed holes.

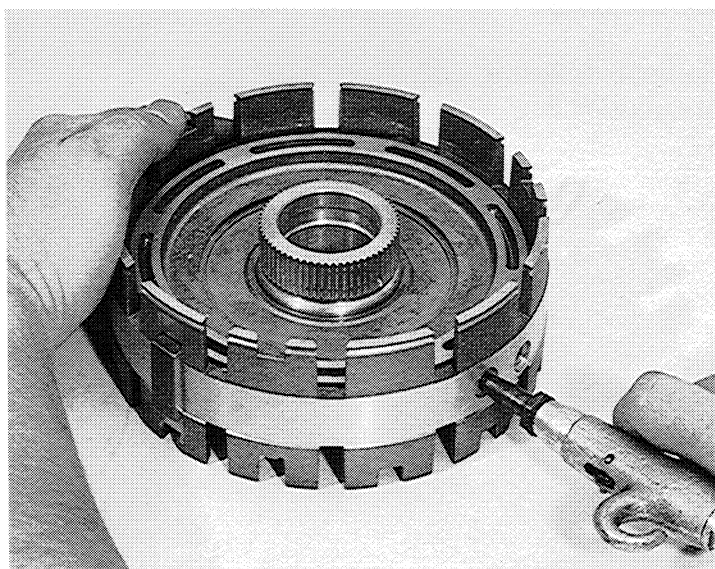

81 113

Removal of plate spring C'  
in the same manner as explained  
for cylinder C-D

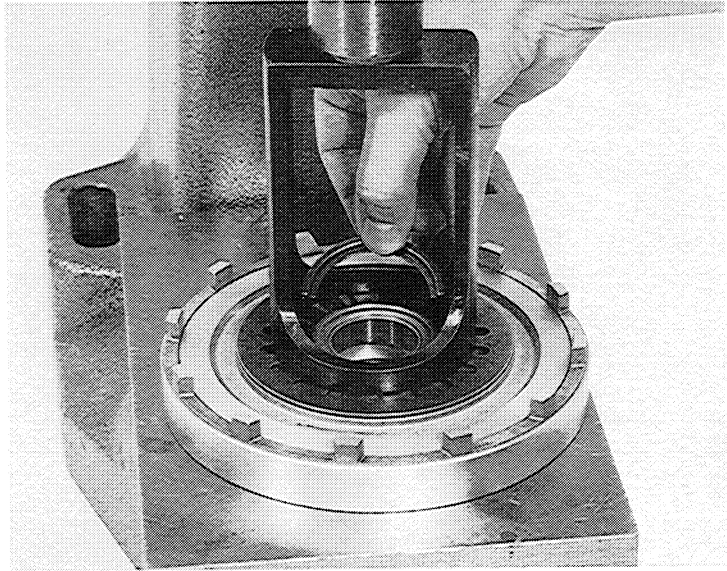

81 115

Use airgun for removal of  
piston C'.

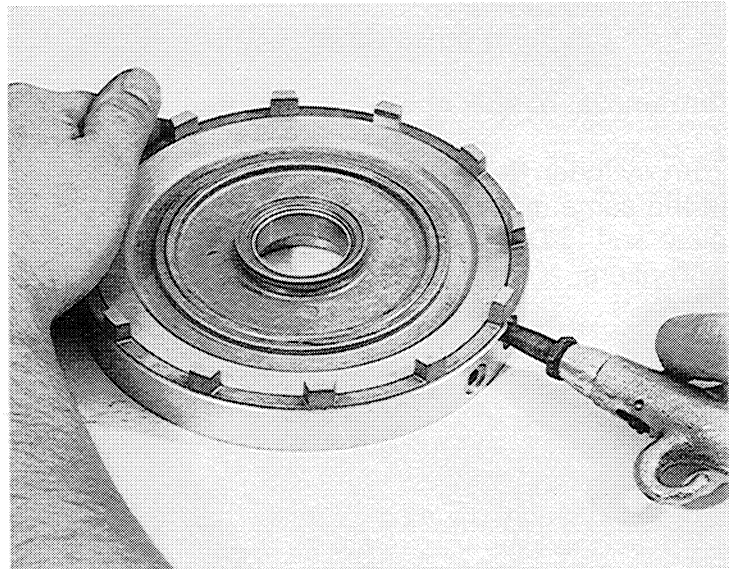

81 091

#### 2.4 Clutch B

Remove snapping out  
of cylinder B.

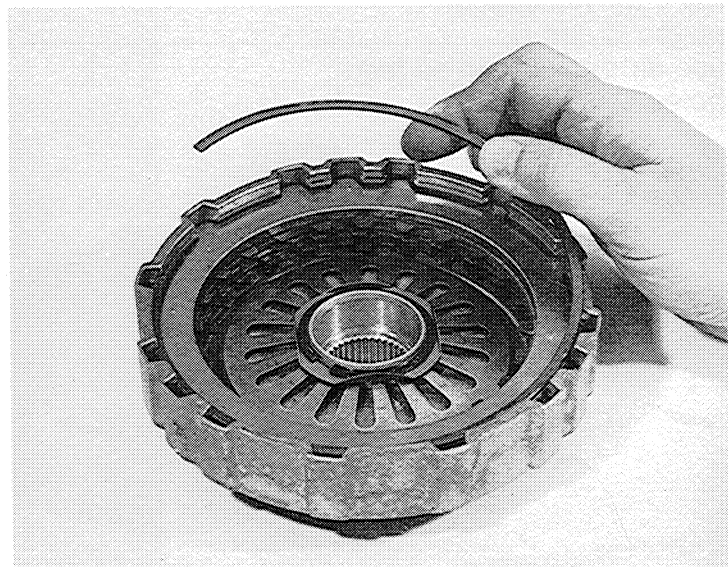



Remove clutch "B" assembly complete.

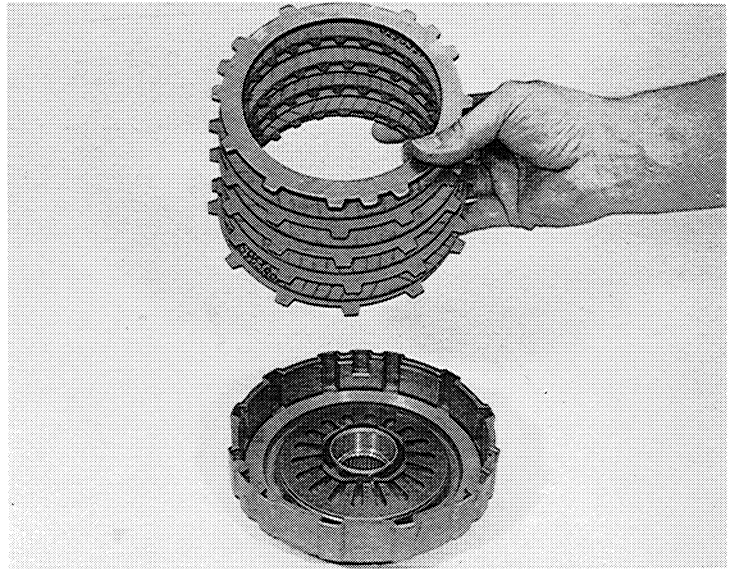

81 093

With spring device (5 X 56 000 093) remove plate spring as explained for cylinder C-D.

Also remove snapping and security washer.

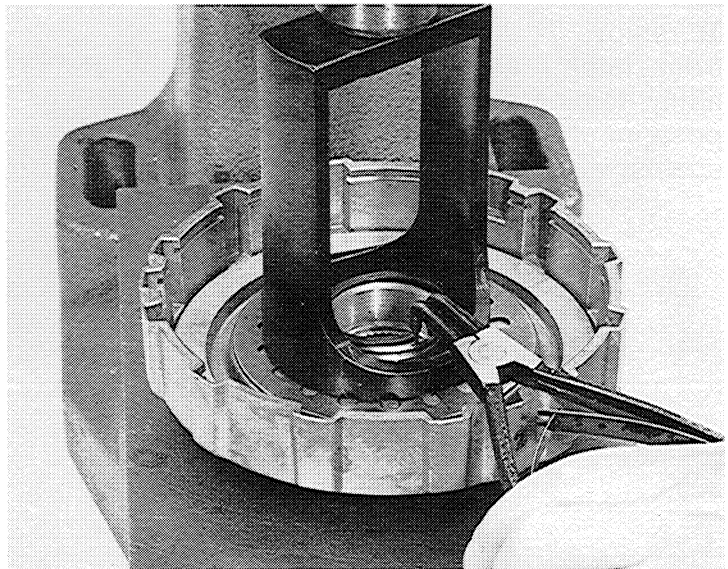

81 094

Fit airgun into oil feedhole for removal of piston B.  
After applying air pressure, turn cylinder B upside-down and tap lightly on work bench.

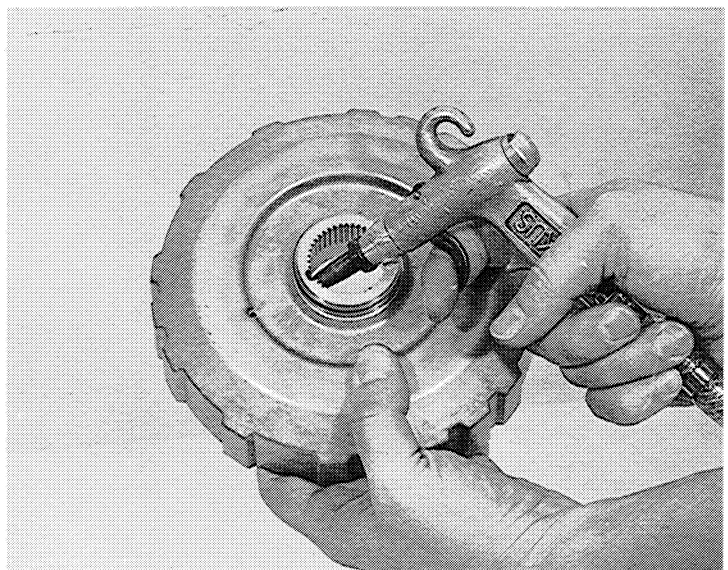

## 2.5 Clutch A

82 062

Remove disc, axle bearing, and thrust washer.

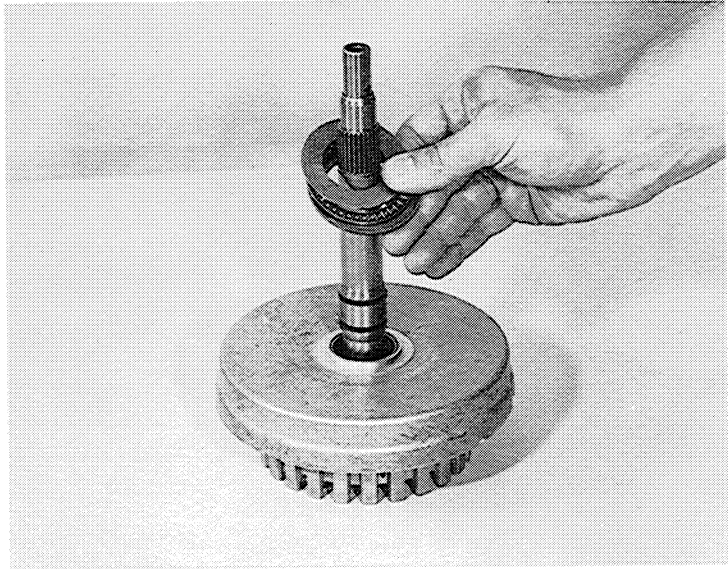

82 063

To remove input shaft from clutch A assembly, firmly holding clutch A assembly, push input shaft down against work bench.

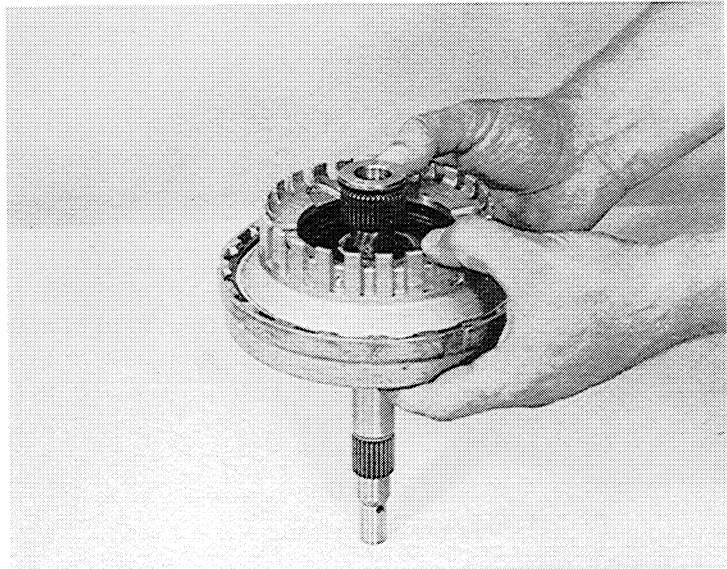

81 097

Using flat metal plate with mounting device (5 X 56 000 094), press down carrier A-B and remove snapping.

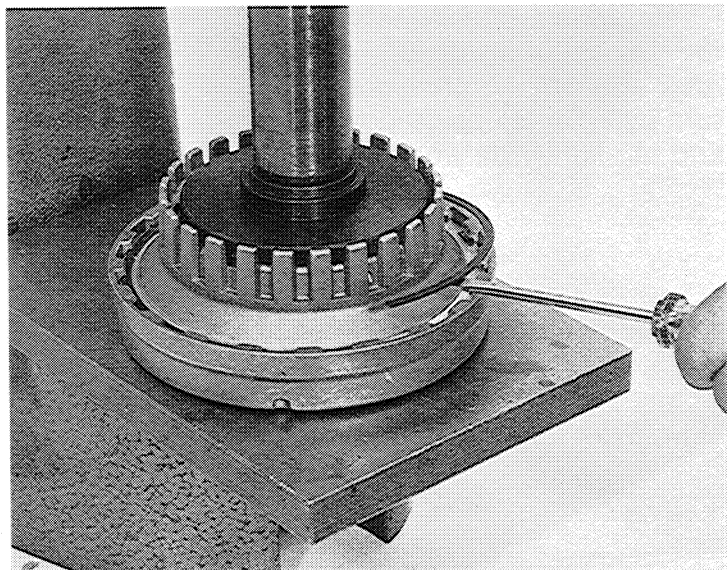

Remove carrier A-B

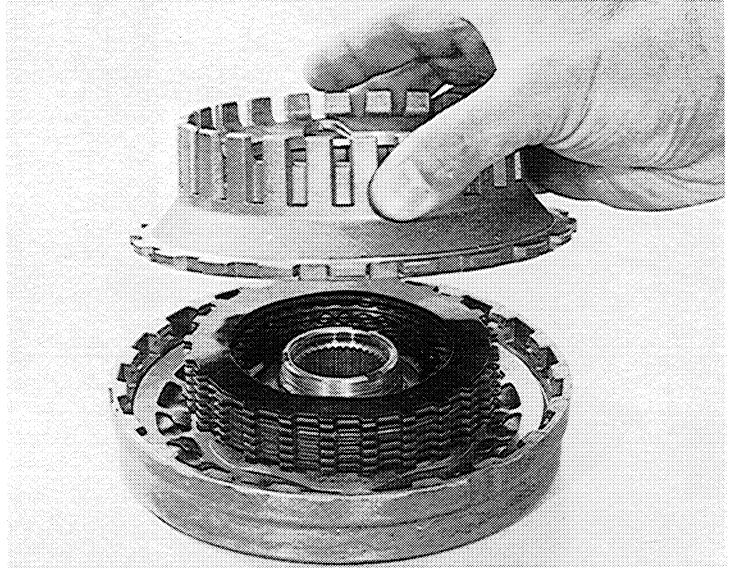

Remove clutch A assembly as well as plate spring A.

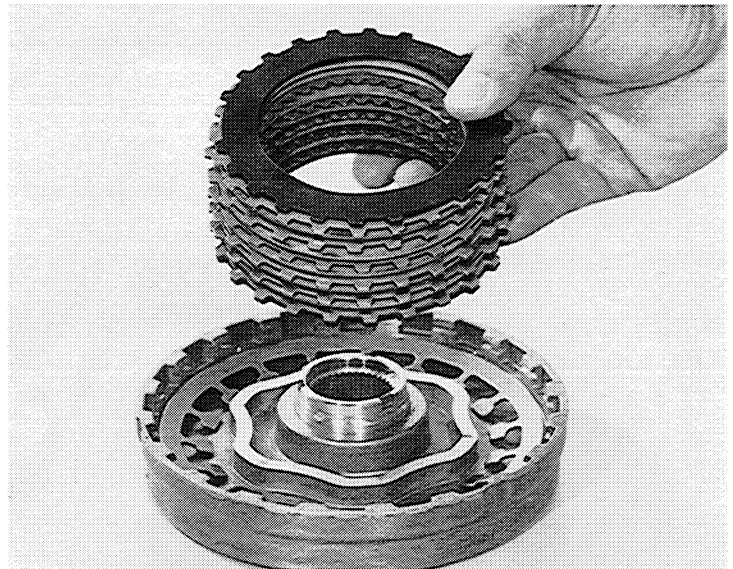

Use airgun for removal of piston A. Apply air pressure into oil feed hole.

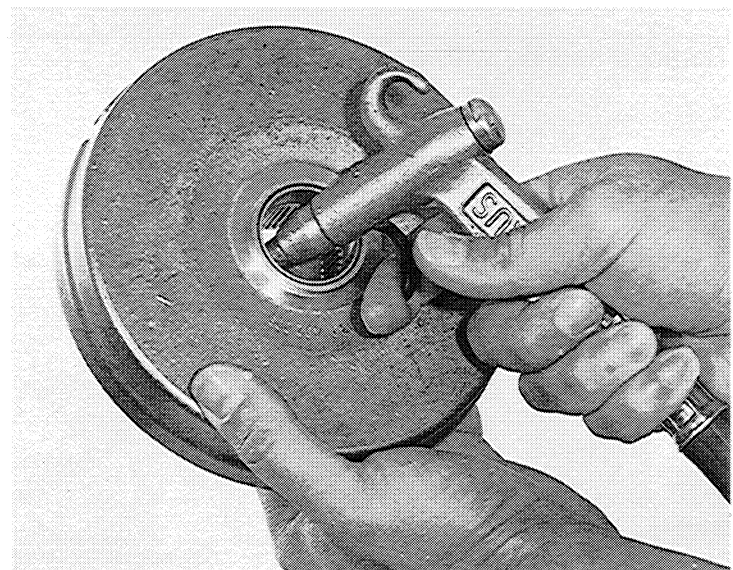



## 2.6 Bellhousing with Intermediate Plate and Pump

82 064

For removal of pump unscrew connection bolts. Select 2 connection bolts which are directly across from each other, screw in 2 turns and rap lightly with plastic hammer for removal at pump. Use tool head size 10mm.

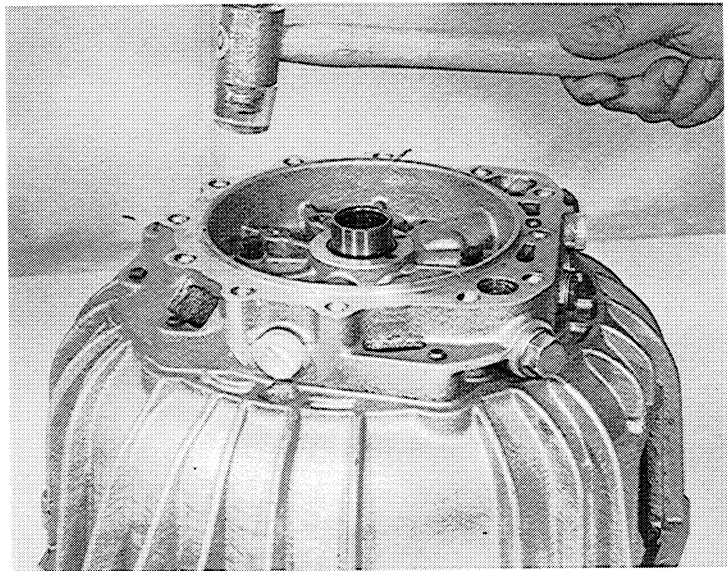

82 065

During normal work procedure do not remove bellhousing from intermediate plate.

If it is necessary to remove intermediate plate, due to damaged or leaking unscrew remaining bolts and remove bellhousing from intermediate plate.  
(Use tool head size 17 mm.)

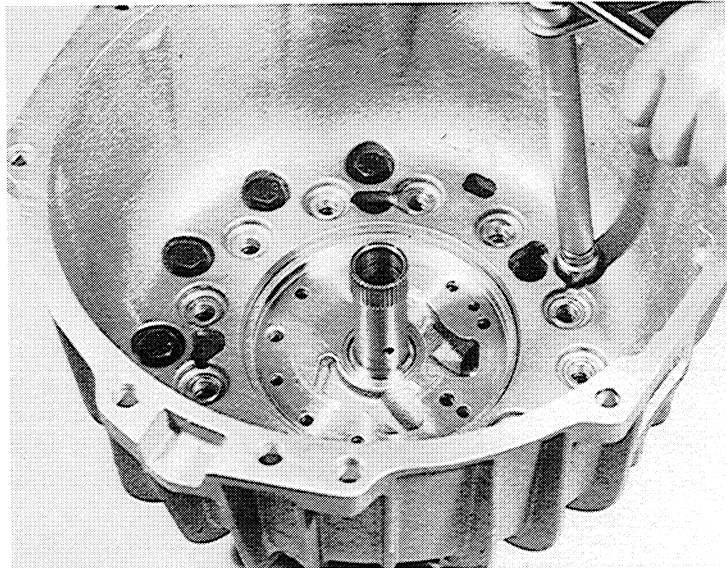

## 2.7 Transmission Extension and Centrifugal Governor

82 066

Remove sealing with screwdriver.

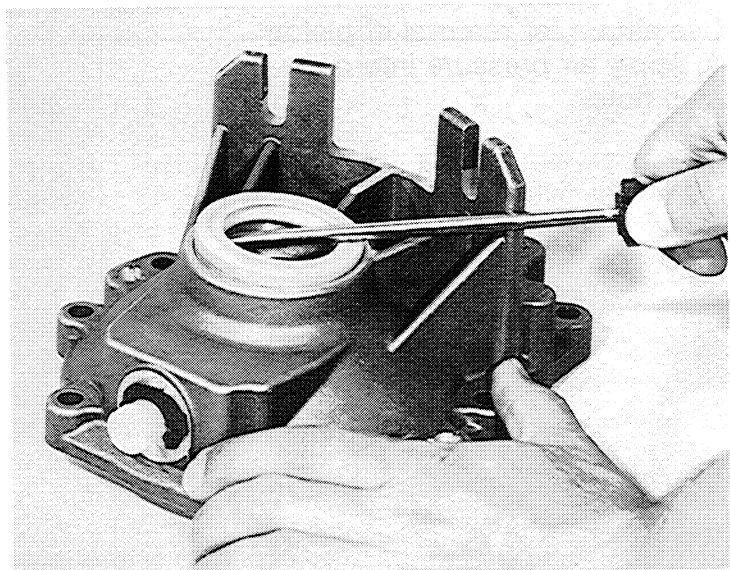

During normal work procedure do not remove needle bearing.

If it is necessary, use punch for removal, as shown in the picture.

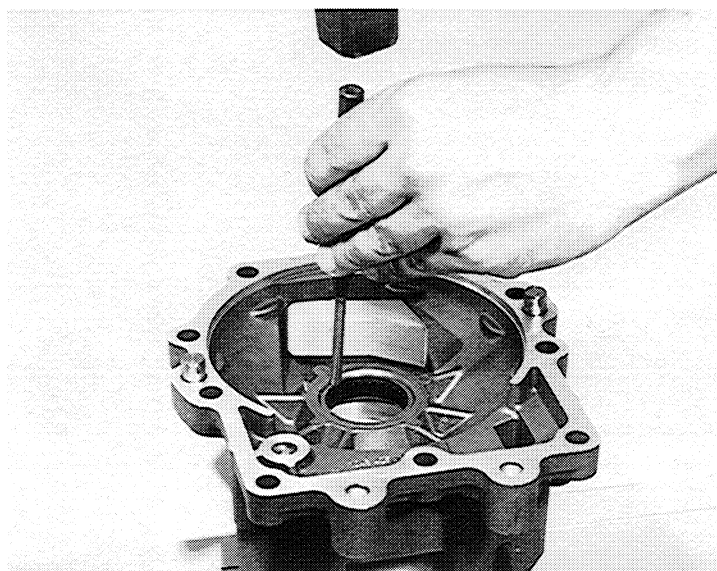

Removal of breather complete. Take off security clip with pliers.

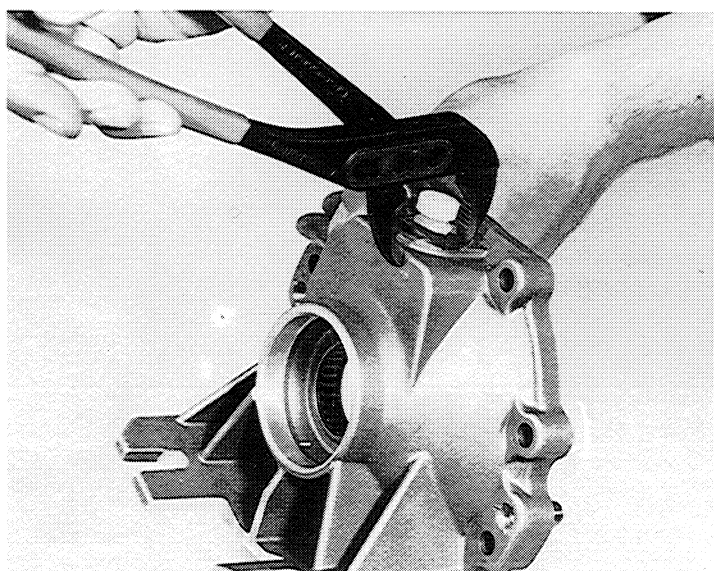

For cleaning of governor assembly, unscrew 2 cylindrical bolts, and remove governor housing complete. Use torx bit TX27.

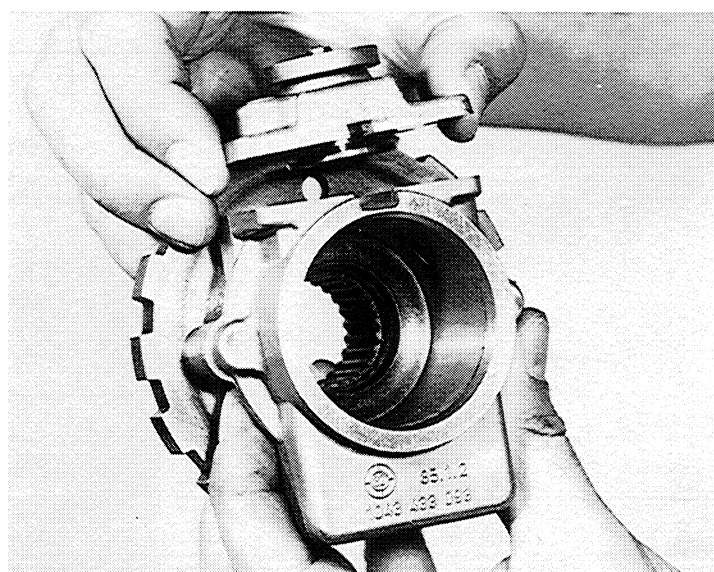

After removal of E clip,  
disassemble governor housing  
complete.

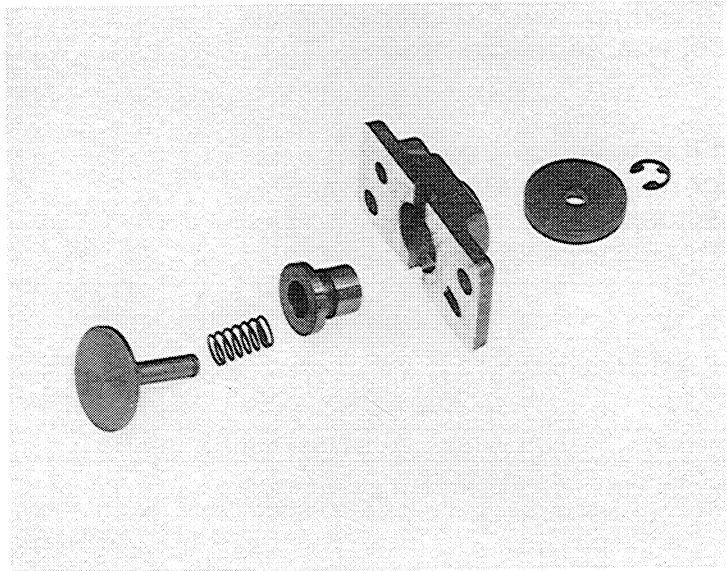

During normal work procedure  
do not disconnect parking  
wheel at governor hub.  
If it is necessary unscrew 2  
cylindrical bolts for disconnection  
at parking wheel.  
After removal at parking wheel  
pull out security clip for removal  
of counter weight.

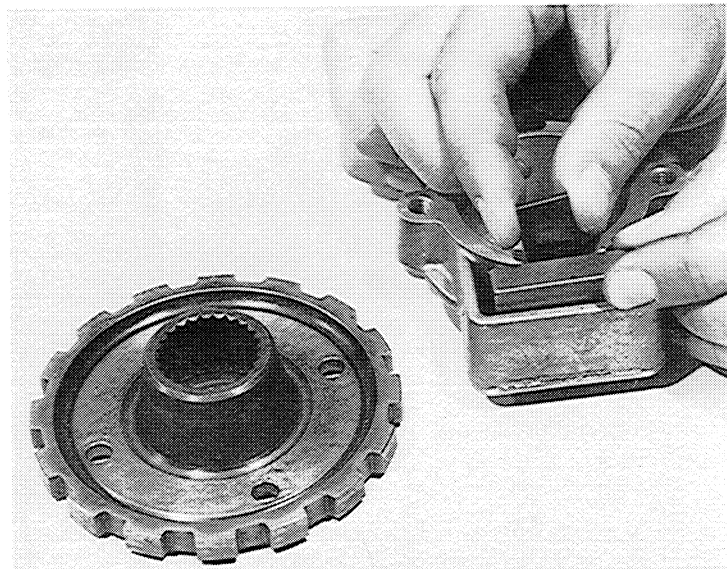

## 2.8 Transmission Case with shift selection

Remove nipple from kick-down  
cable out of cam seat.

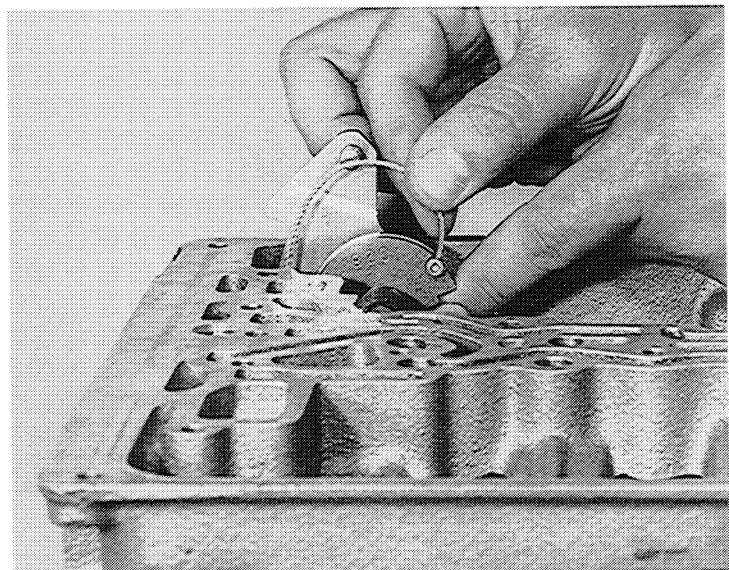



Removed kick-down cable from transmission case with 2 screw drivers as shown.

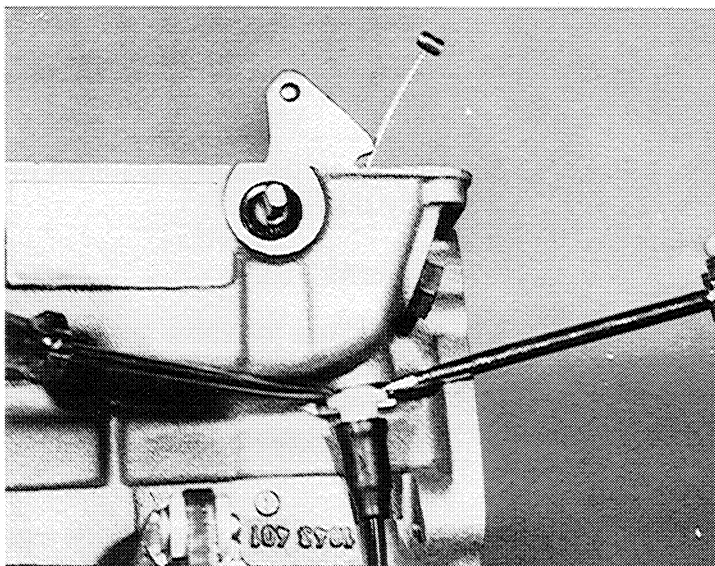

Normally selector and park assembly are left in transmission housing. If removal is necessary use punch to remove roll pin in selector shaft.

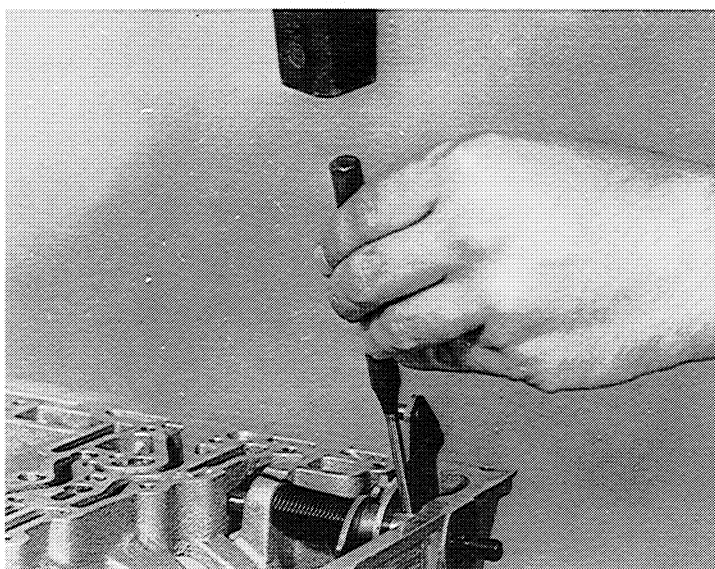

After removal at selector shaft, take out stop washer, connection rod cam, and legspring.

Also remove seal ring in transmission case with screwdriver.

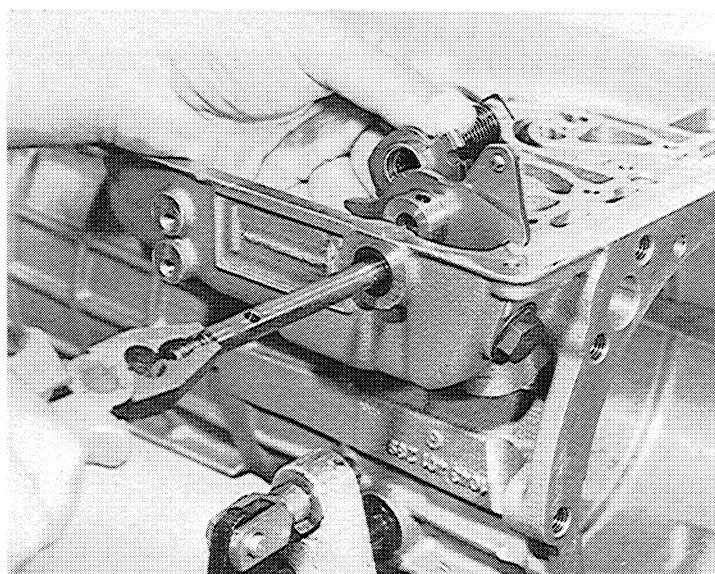

Following conditions are required prior to valvebody disassembly.

**Requirements**

- 1.) Workplace for valve body repair
- 2.) Special tools
- 3.) Transmission) - Teststand
- 4.) Part number information and technical updates

Valve body repair manual will be available to insure proper repair procedure.

### 3. Assembly

#### 3.1 Transmission Case with Selector and Park Assembly

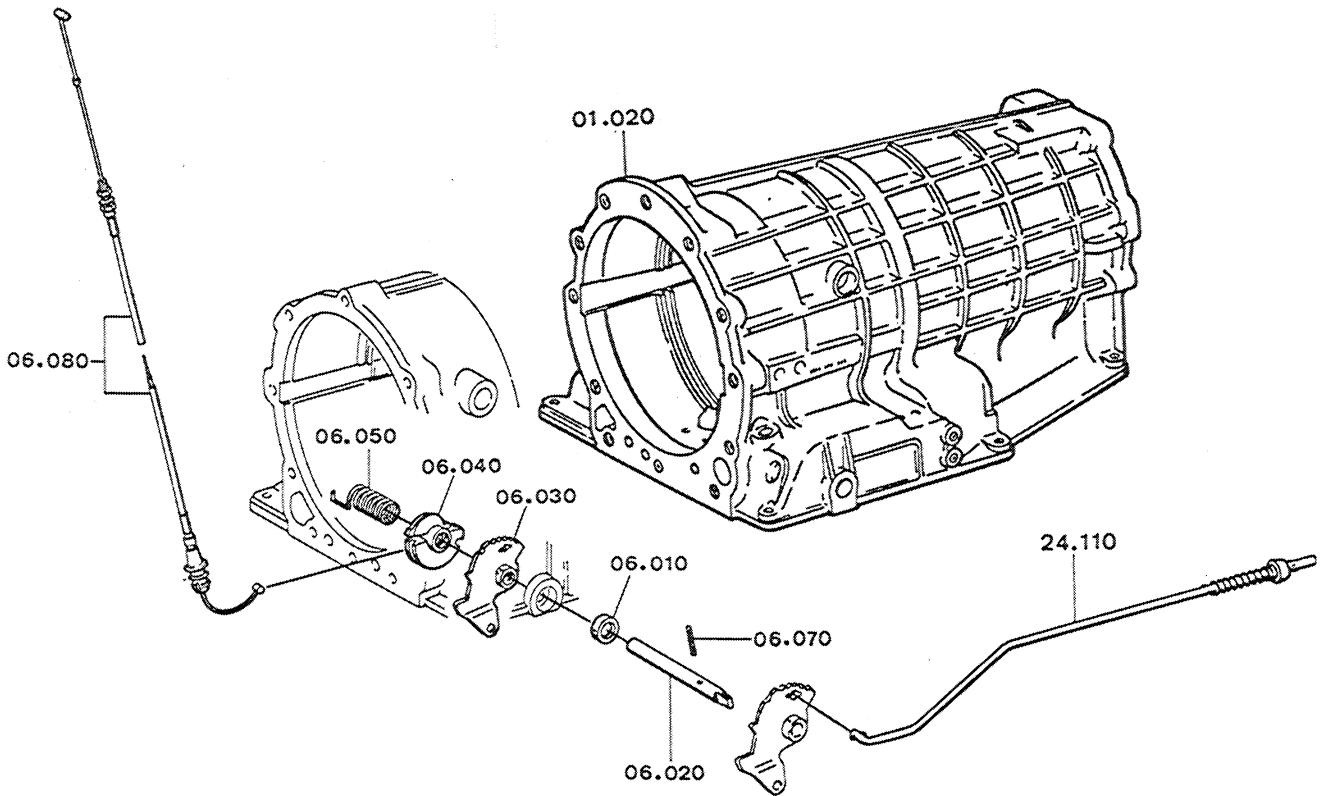

82 083

Fit in new searing 06010  
with suitable punch into  
transmission case 01020.

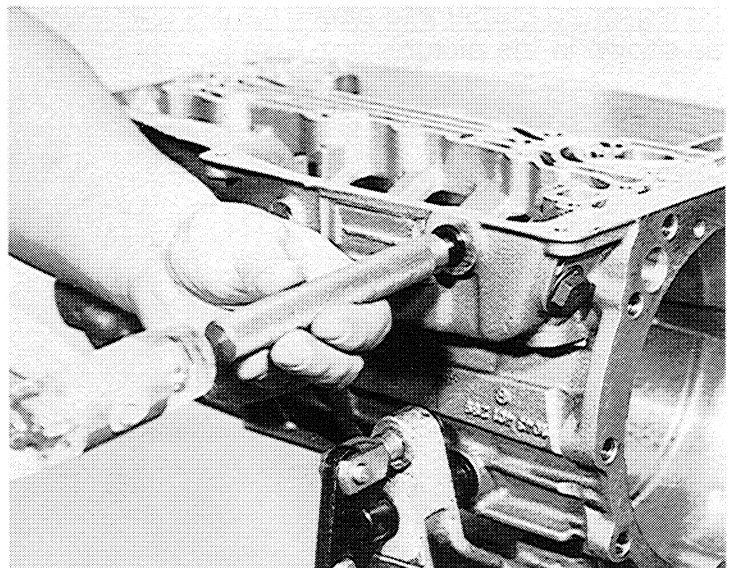

82 084

Fit connection rod 24110 into stop washer 06030 as shown.

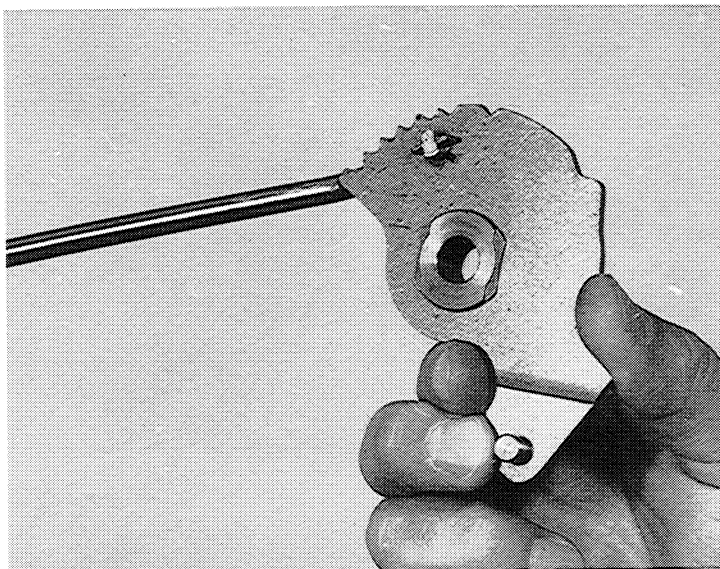

82 085

Place stopwasher with connection rod into transmission case, and put in selector shaft 06020.

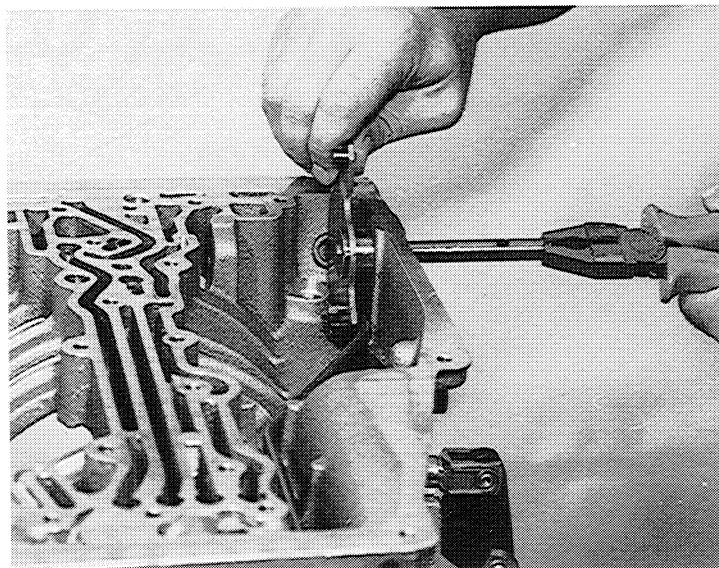

81 201

Fit legspring 06050 into cam as shown in the picture.



Install cam together with  
legspring and insert selector  
shaft to stop point.  
Align hole in selector shaft  
with hole in stopwasher.

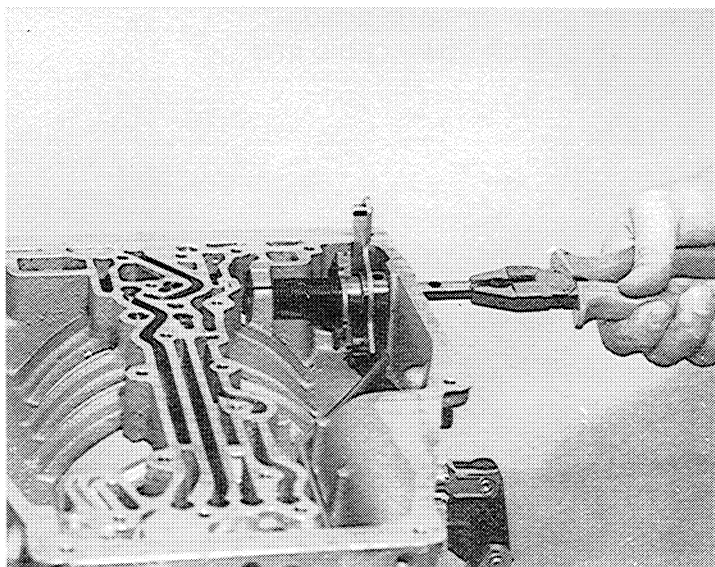

Use new roll pin 06070 with  
suitable punch, install roll  
pin, with open side facing  
rear of transmission.

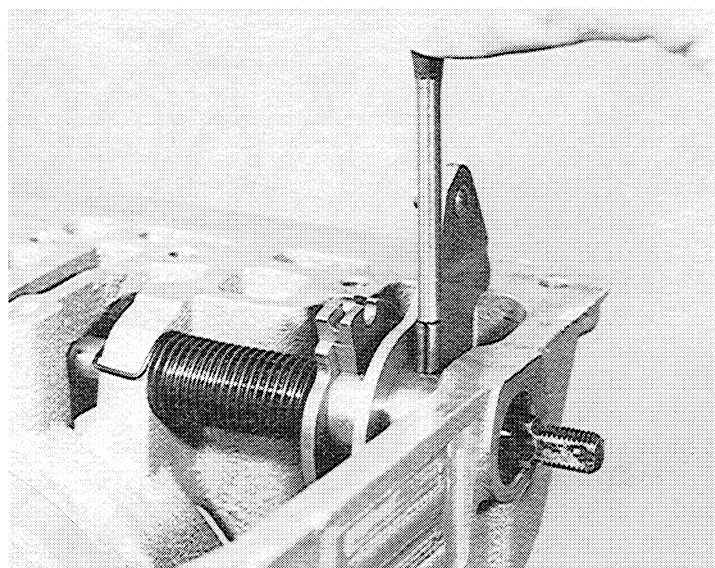

Install new kick-down cable  
06080 into seat at transmission  
case.

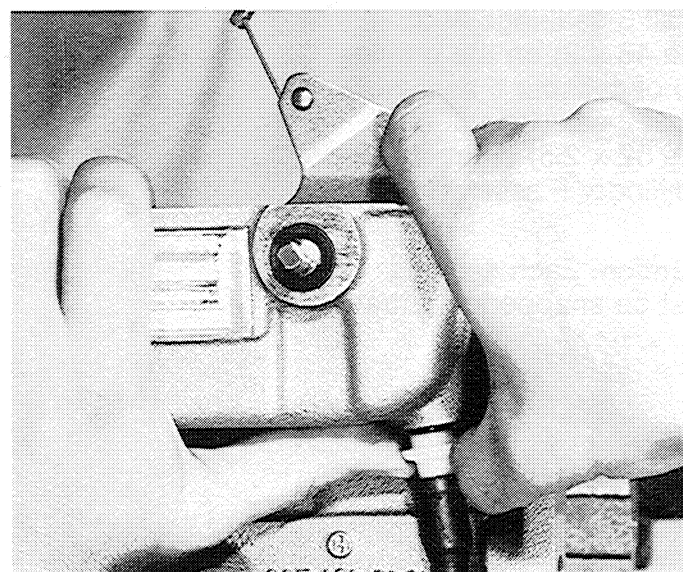



Turn cam once for springload.  
Fit nipple of kick down cable into  
cam seat.

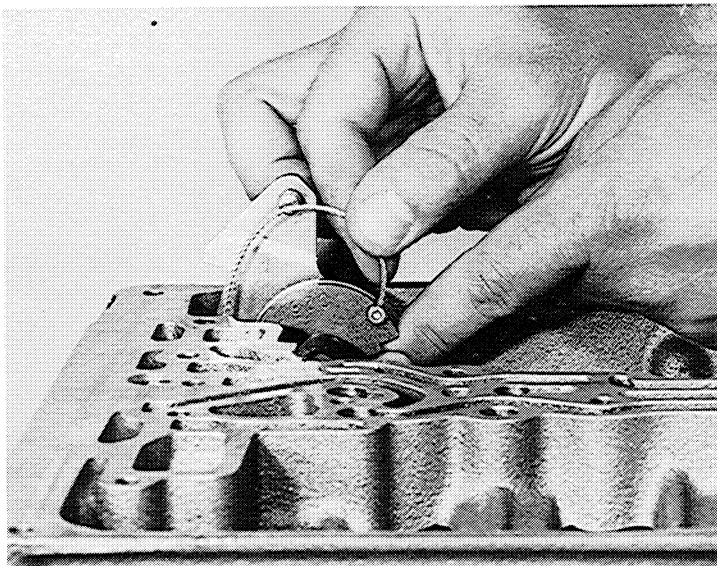

### 3.2 Brake F

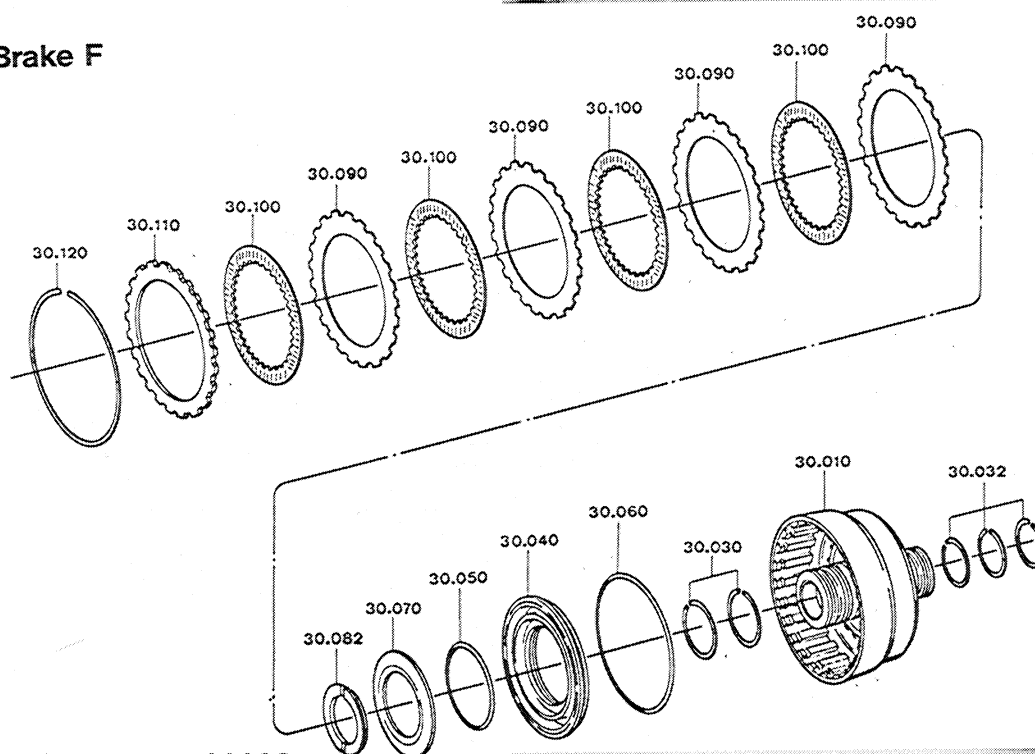

82 089

Install 3 sealrings 30032  
(size 48 x 2) on the outside  
hub of cylinder F assembly.  
Install 2 sealrings 30030  
(size 52 x 2.5) on inside hub  
of cylinder F assembly 30010.

**Attention:** Each sealring  
must be snapped together.

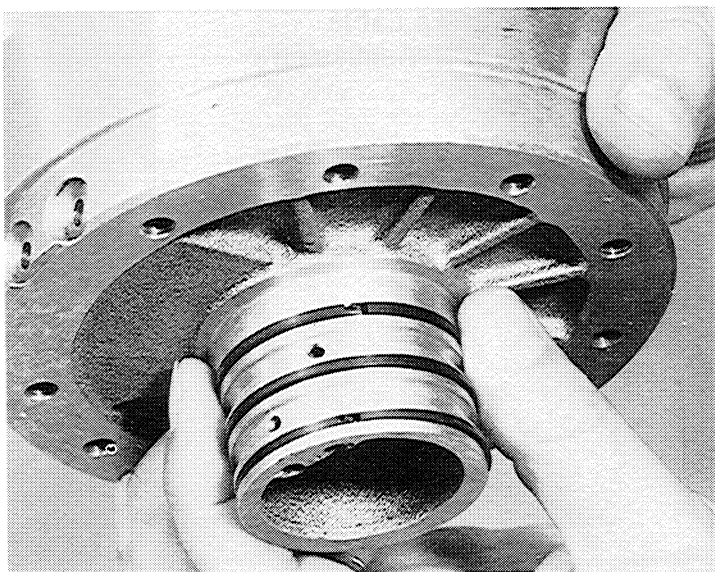



Install piston F 30040 with o-rings 30050 and 30060 into cylinder F.

For easy assembly use light grease (Vaseline) on o-rings.

To avoid damage to inner o-ring stretch inner o-ring prior to installation.

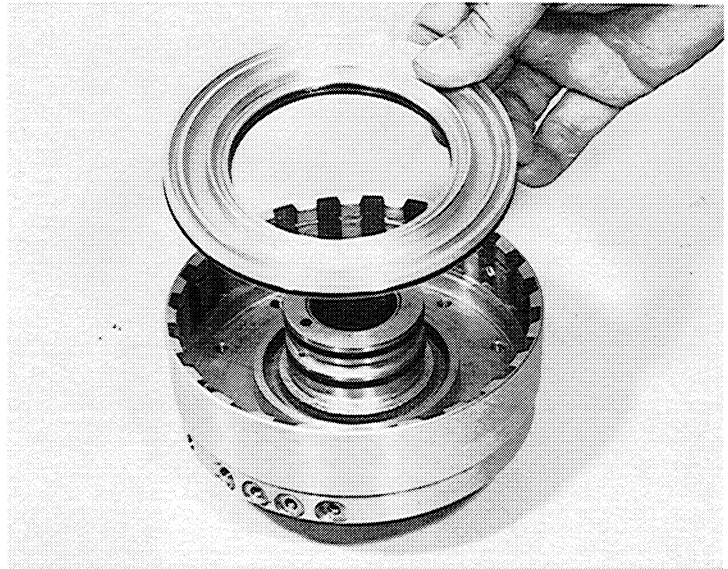

With spring device (5 X 46 000 167) press down plate spring (F 30070) and secure with split rings (30082).

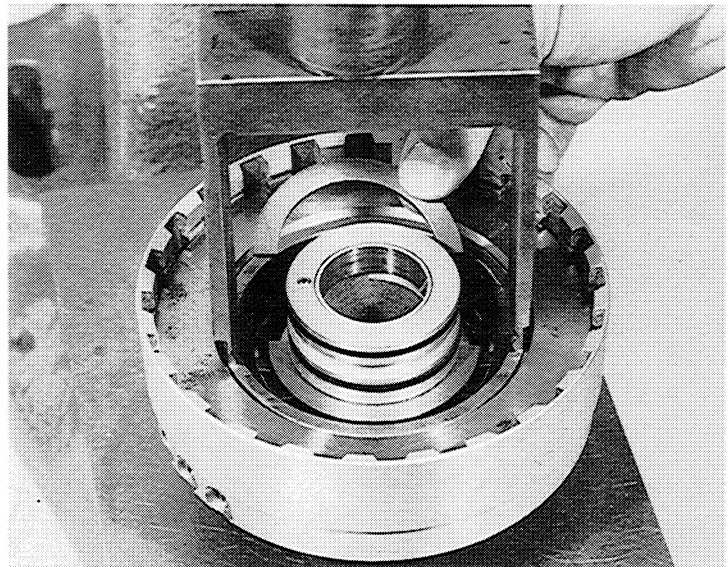

Install brake F assembly into cylinder F. Start with steel plate 30090.

**Attention:** Do not mix up steel plates with those in clutch E.

Difference  
 30090 - steel plates thicker  
 30100 - clutch plates same  
 30110 - end plate without inner teeth

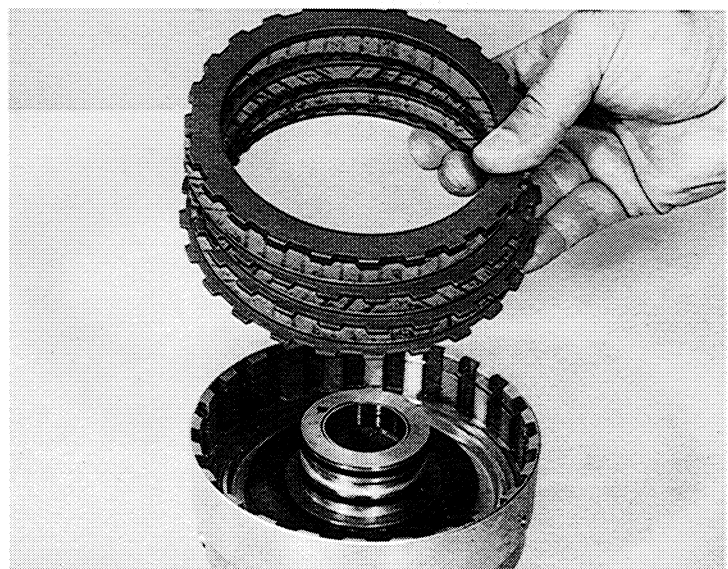

Secure endplate with snapping 30120.

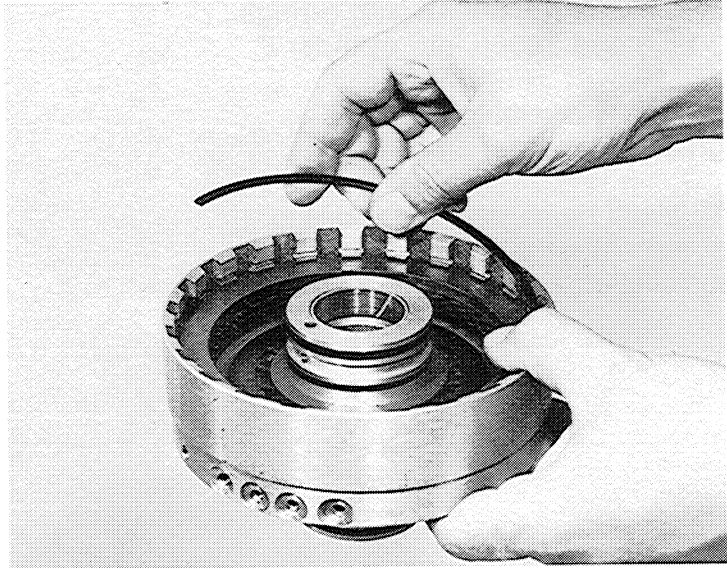

### 3.3 Clutch E

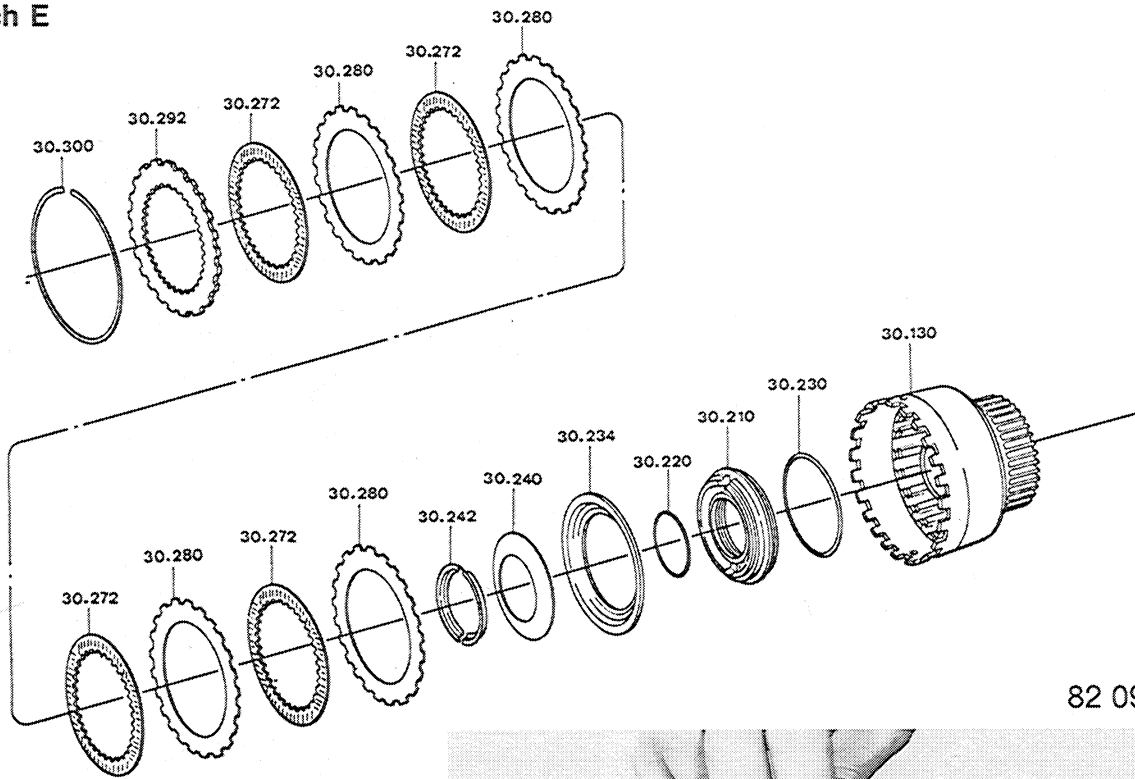

Install snapping 30311 with cylinder E 30131 (version with groove).

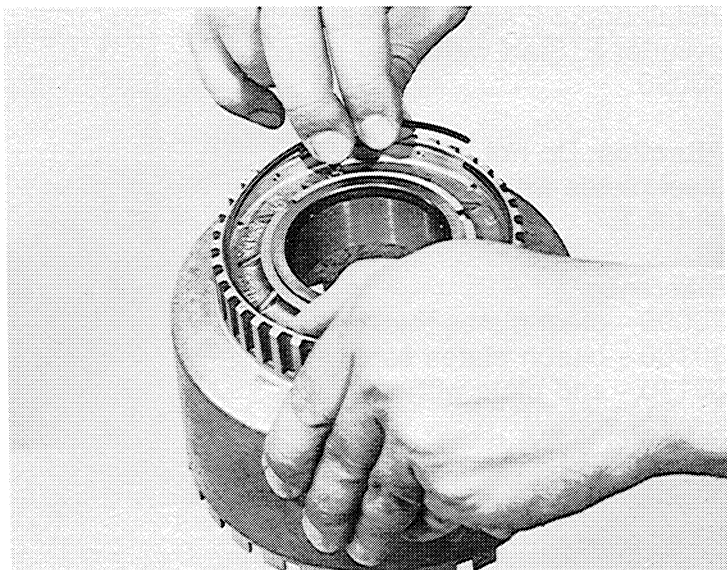

Install piston E 30210 together with o-rings 30220 and 30230 into cylinder E.

For easy mounting use light grease (Vaseline).

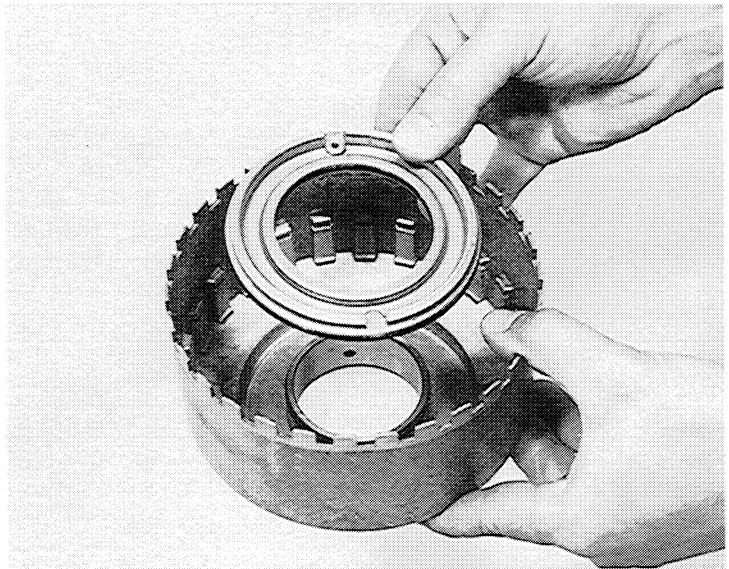

Install pressure plate 30234 with curve facing downward as shown in the picture.

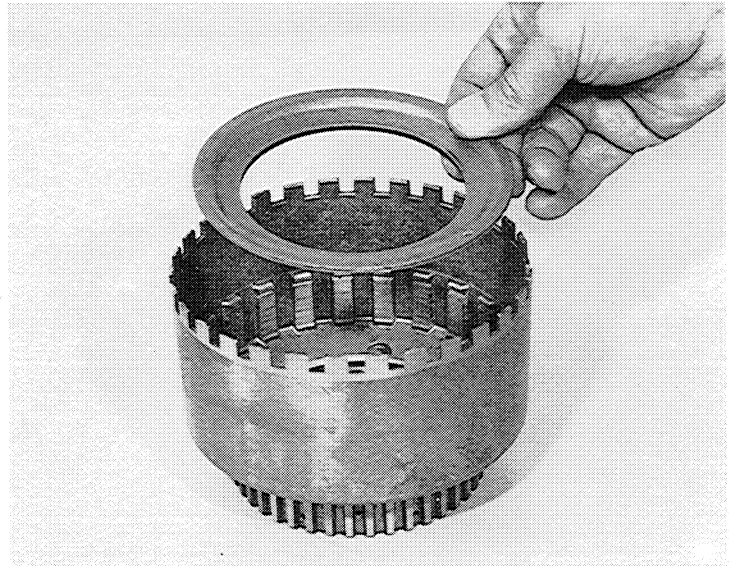

With spring device (5 X 46 000 167) press down plate spring E 30240 and secure with split rings 30242.

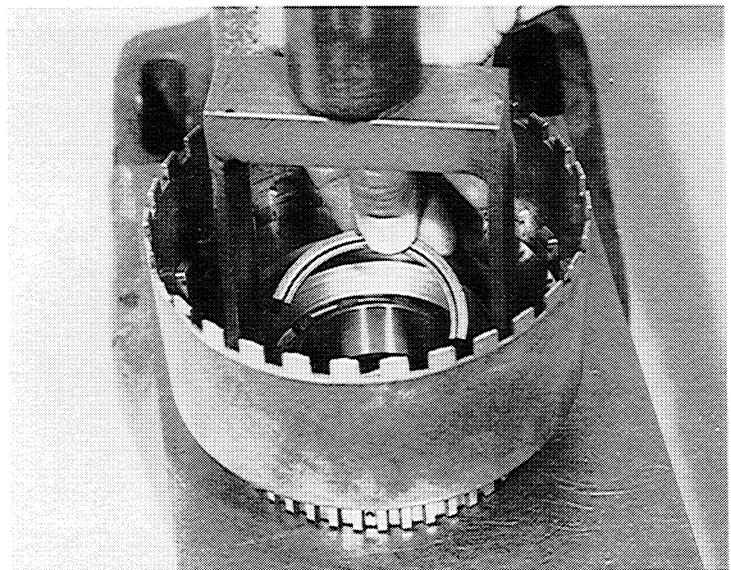

Install clutch E assembly into cylinder E.

Start with steel plate 30280

**Attention:** Do not mix up steel plates with those in brake F.

**Difference**

30270 - clutch plates same  
30280 - steel plates thinner  
30292 - endplate has inner teeth.

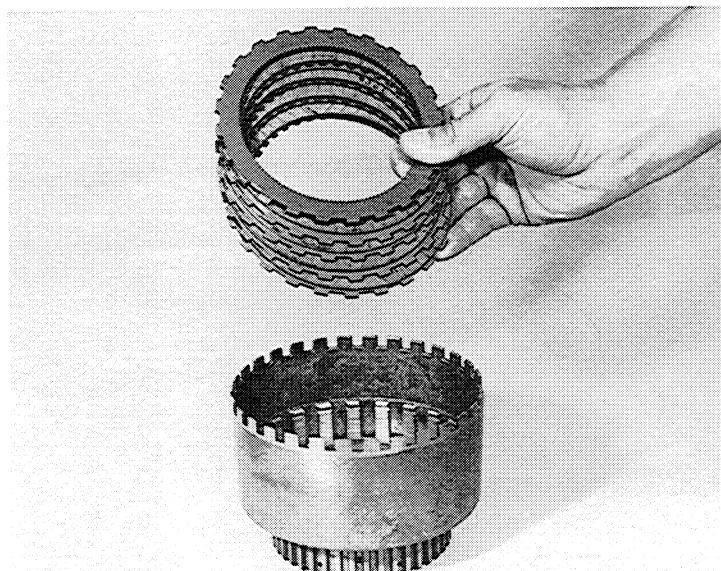

Secure endplate with snapping 30300.

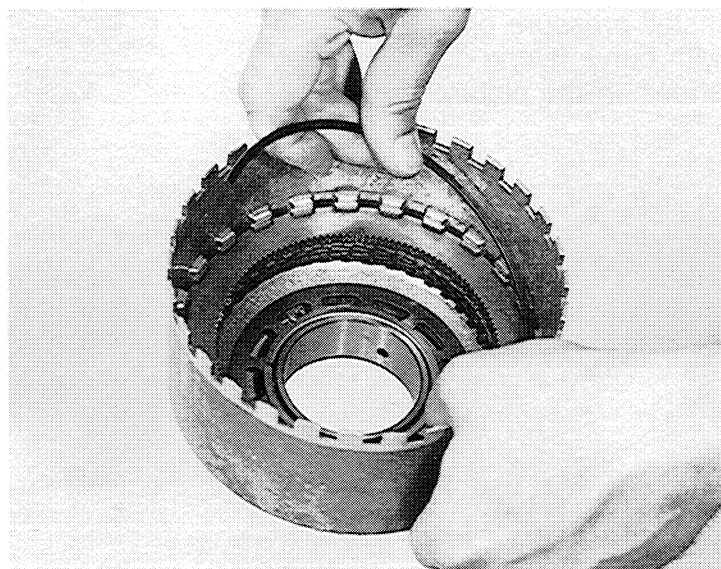

### 3.4 Mounting and Assembly of 4th Gear Complete

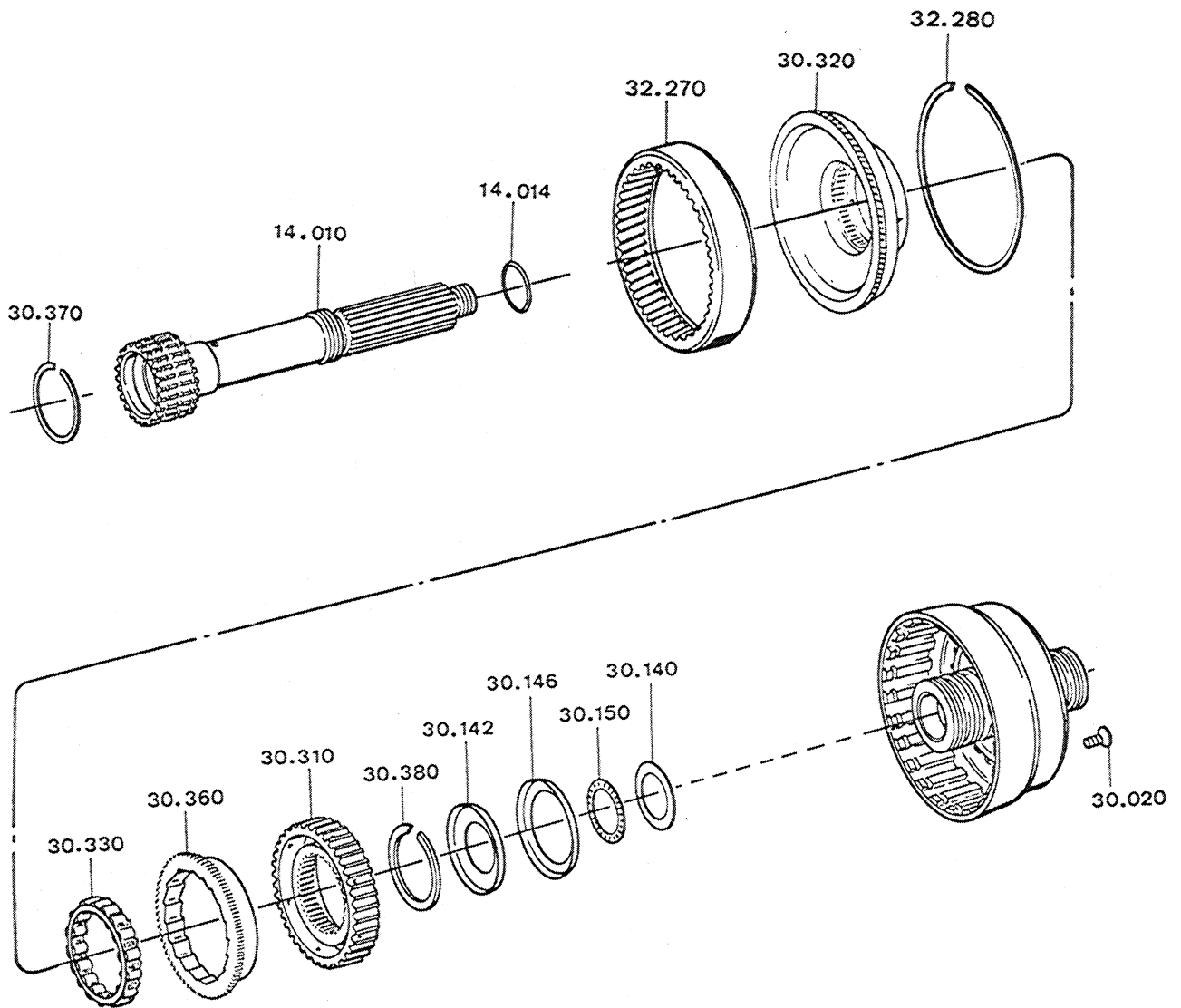

82 095

Connect freewheel inner ring 30320 together with hollow gear 32270 and secure with snapping 32280.

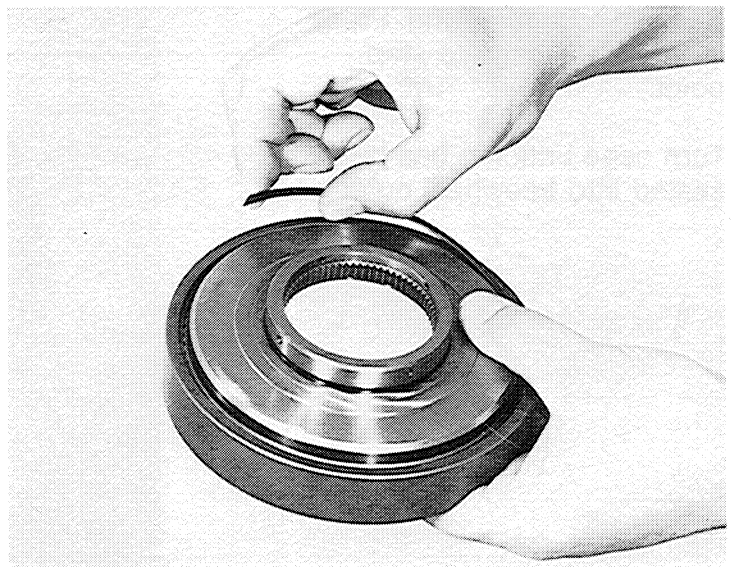



Line up freewheel cage 30330  
against freewheel outer ring  
30360.

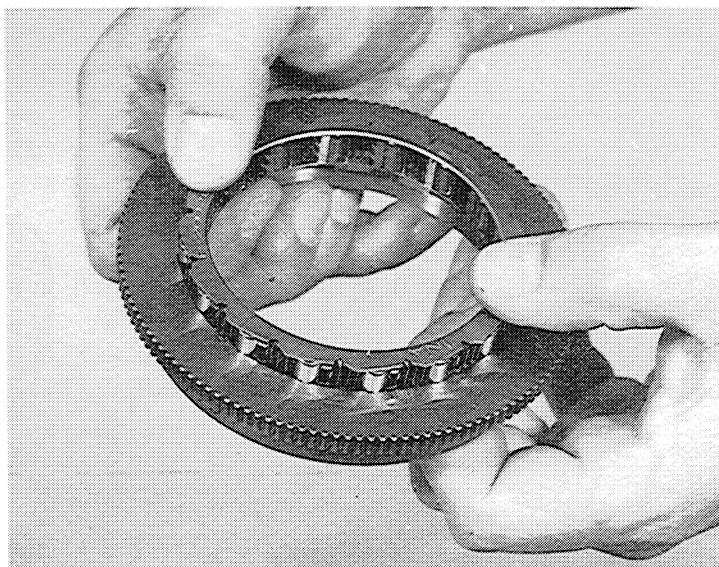

With mounting ring  
(5 X 46 000 169) press  
freewheel cage together and  
install into freewheel outer  
ring.

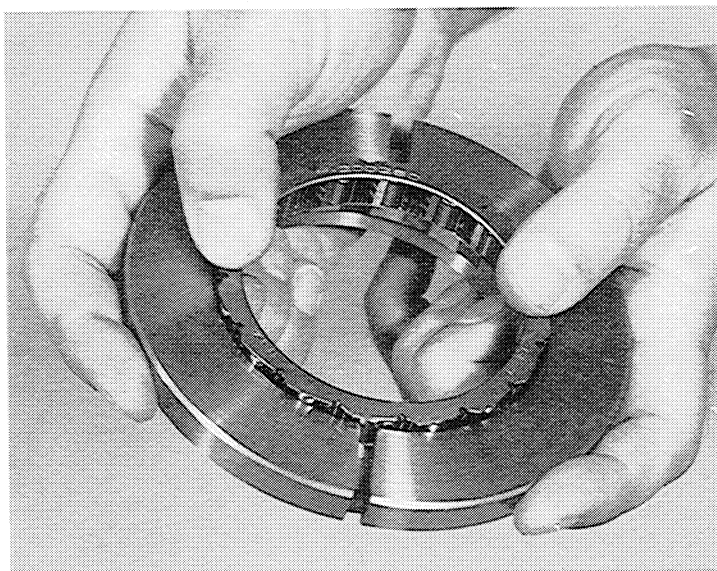

Remove mounting ring. Press  
in freewheel cage to stop  
point.

Turn cage until rim has been  
seated into freewheel outer rim.

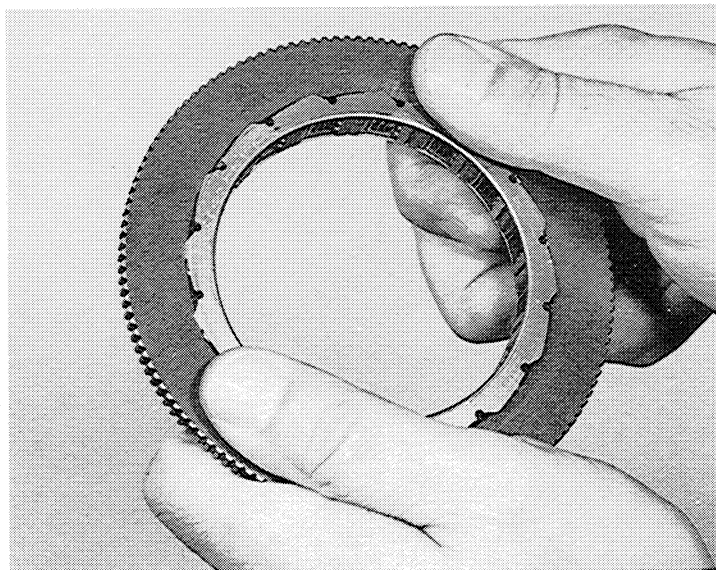

Place carrier E 30310  
together with freewheel  
outer ring.

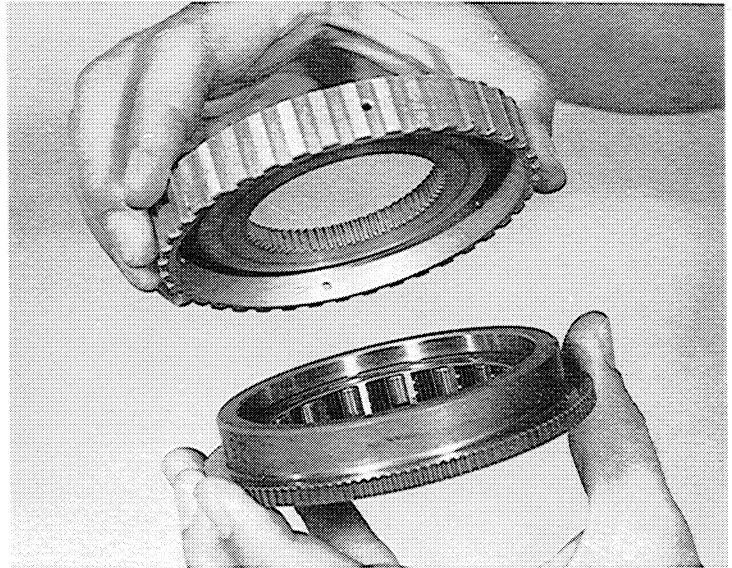

Grasp carrier E along with  
freewheel outer ring. With  
clockwise motion insert onto  
freewheel inner ring.

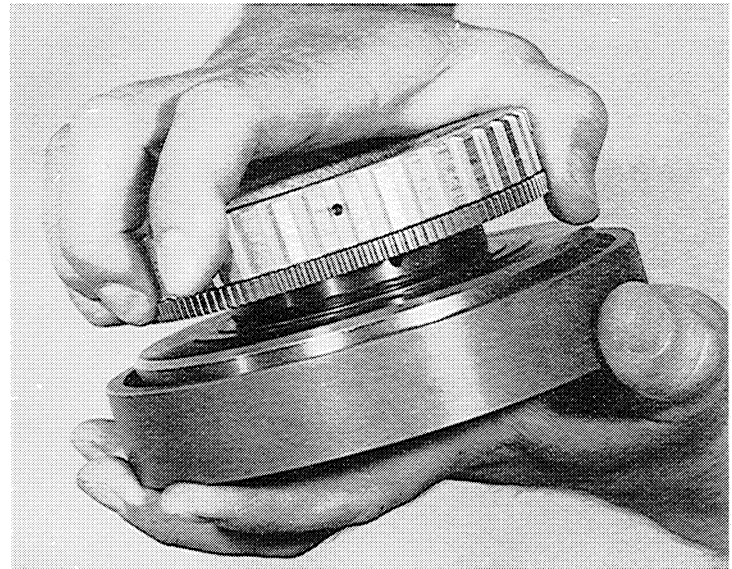

Minimum clearance between  
freewheel inner ring and outer  
ring must be 0.1 mm.

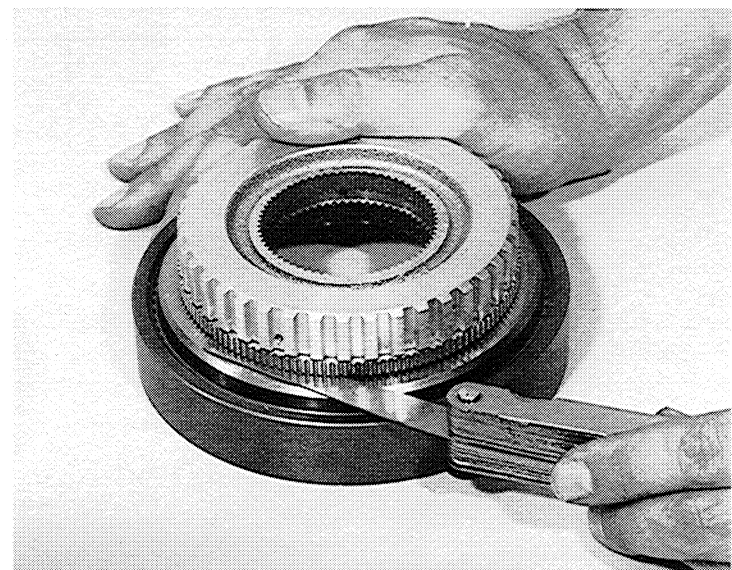

Place output shaft 14010 on special mounting tool (5 X 46 000 168). Also install o-ring 14014 and snapping 30370 on output shaft.

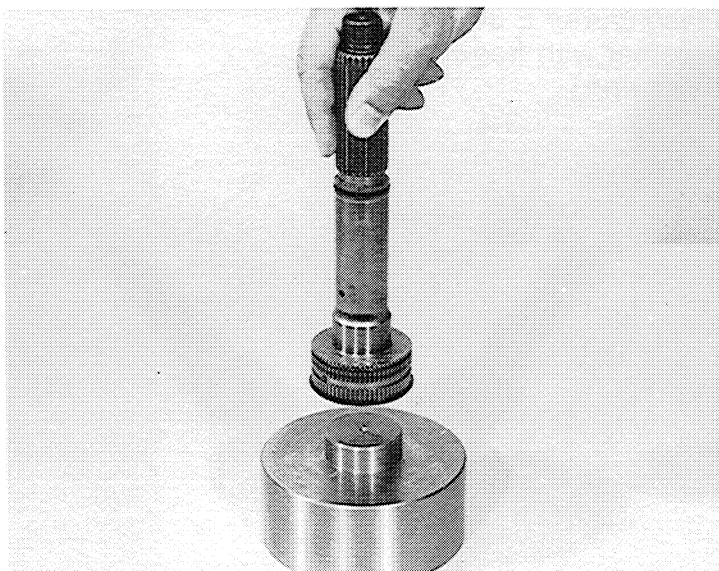

Align inner teeth of carrier E with freewheel inner ring. Insert freewheel assembly onto output shaft.

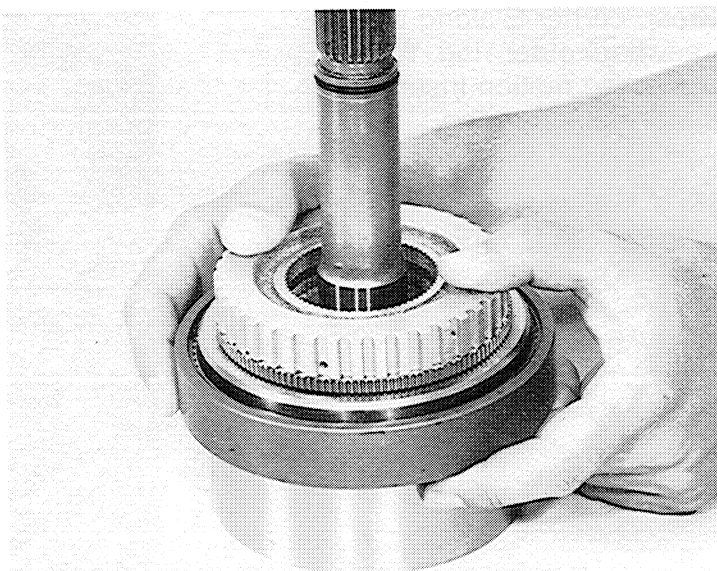

Place snapping 30380 onto mounting sleeve and push down with mounting tube.

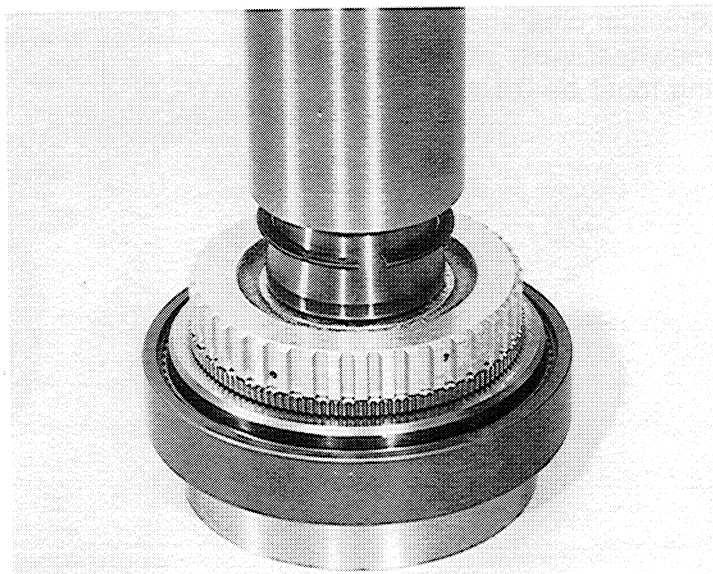

Install first steel thrustwasher 30142, second copper thrustwasher 30146 as shown in the picture.

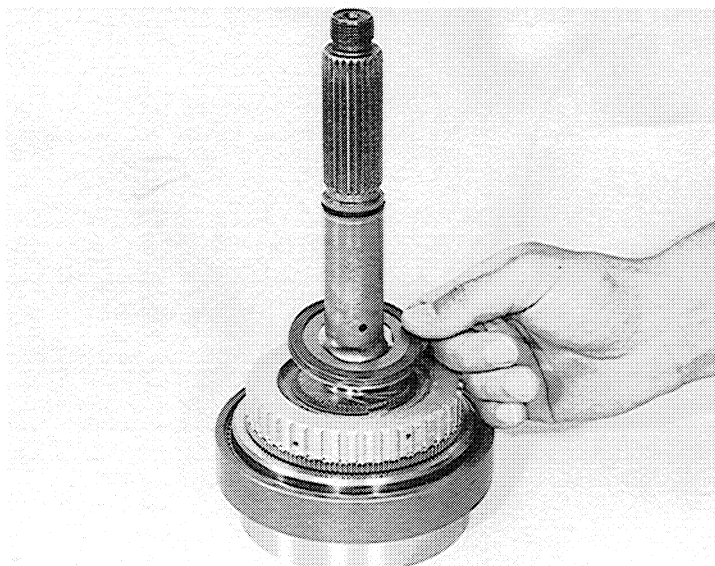

Install cylinder E assembly with turning motion.

**Attention:** Line up teeth at end plate with freewheel outer ring. Copper thrustwasher must be connected with cylinder E assembly.

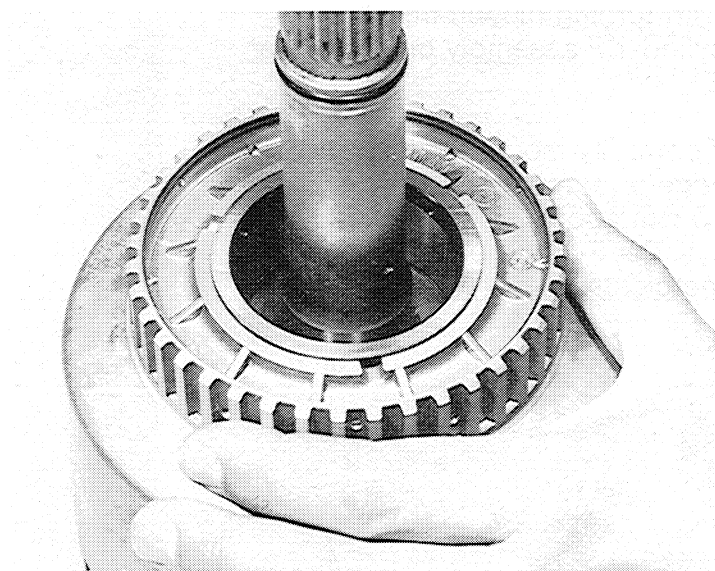

If correctly mounted cylinder E assembly must be turning in clockwise direction by holding output shaft in place.

If turning counterclockwise freewheel must be locked up.

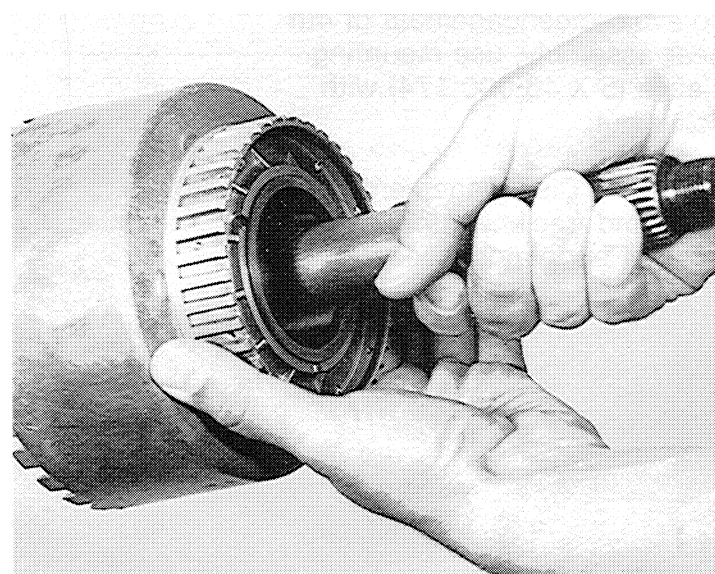



Insert axle cage 30150 and axle disc 30140.

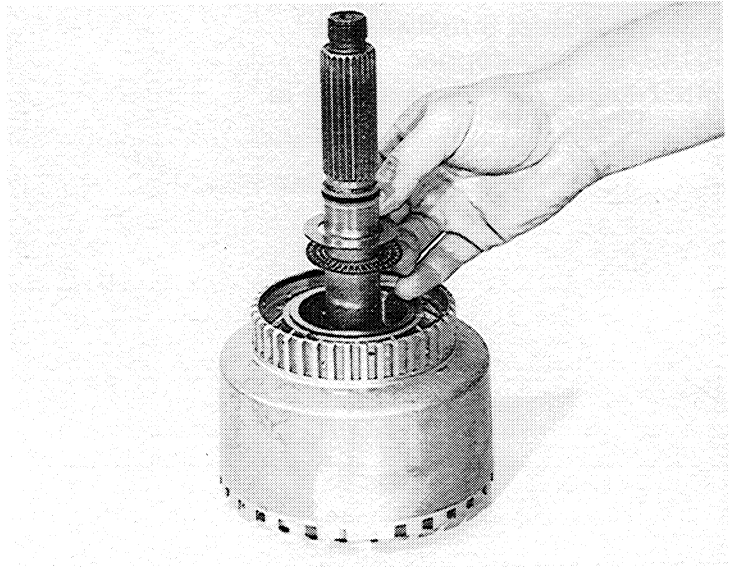

With turning motion install cylinder F assembly onto cylinder E.

If correctly mounted, the raised edge of output shaft will be 10 mm above top surface of cylinder F assembly as shown in the picture.

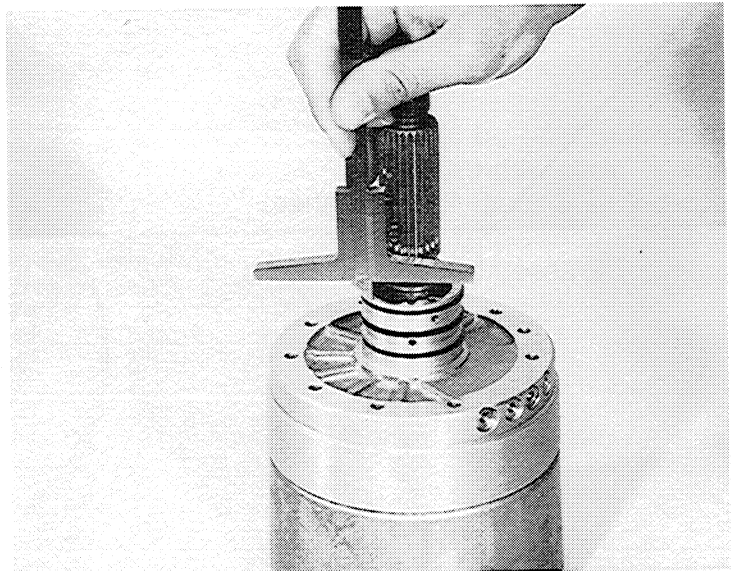

To avoid disengagement of 4th gear assembly, use mounting sleeve (5 X 46 000 174) with collar nut.

**Attention:** Disengagement of end-plate and freewheel inner ring will occur if endplay exceeds 3 mm.

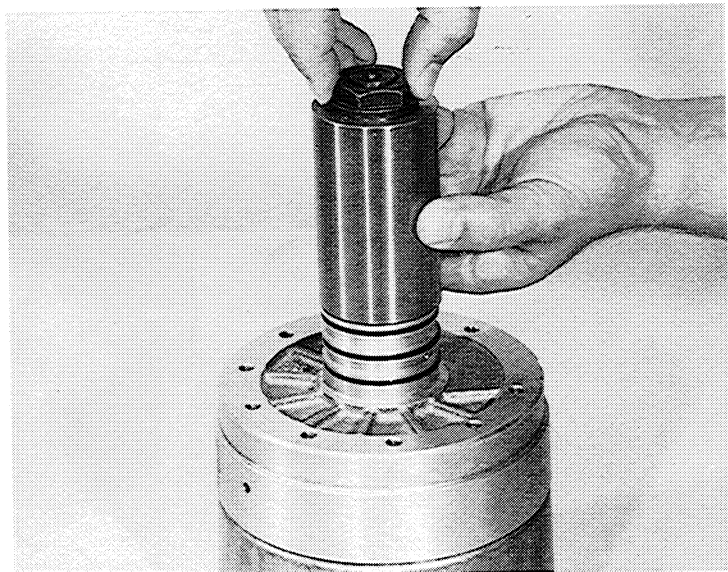



Install 4th gear assembly complete into transmission case.

Also take notice that oil feed holes from cylinder F line up with holes in transmission case.

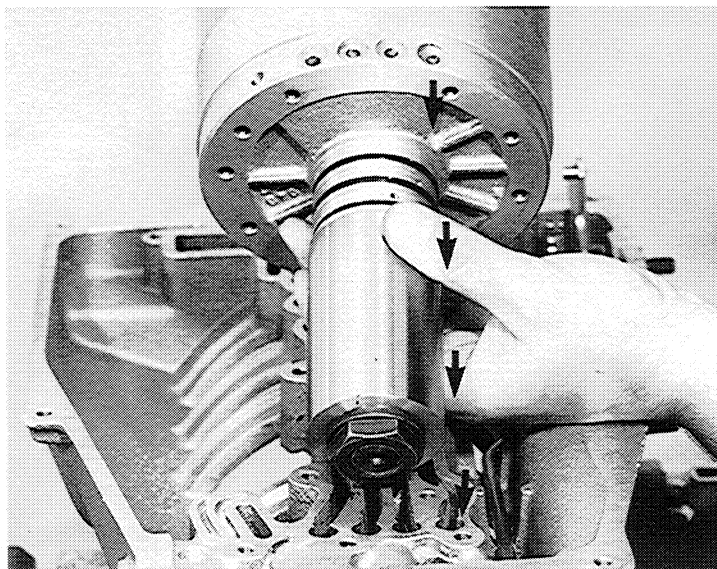

82115

Use 10 counter sunk screws 30020 for tightening at cylinder F.

**Attention:** If screws are not tightened up properly, clutch pressure will be lost in clutch F. Use torx bit TX 30 (To be torqued 10 Nm.)

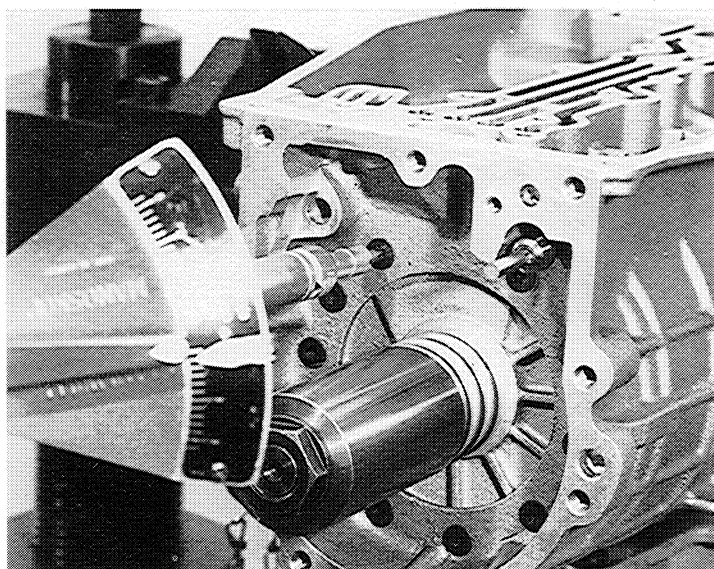

### 3.5 Park Mechanism

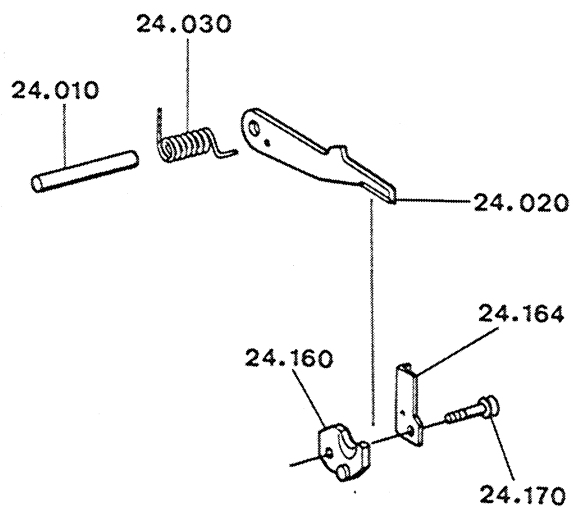

82 116

Install pin 24010 and leg spring 24030 as shown in the picture.

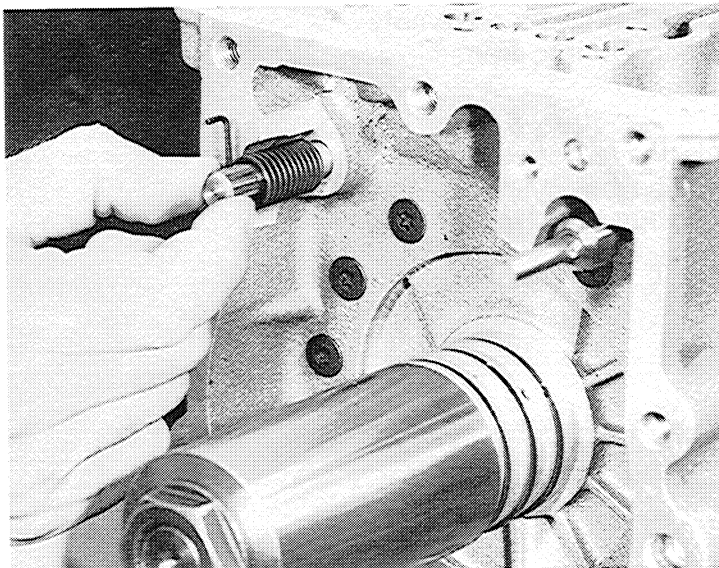

82 117

Install pawl onto pin. For tensioning, fit leg from spring into hole of pawl.

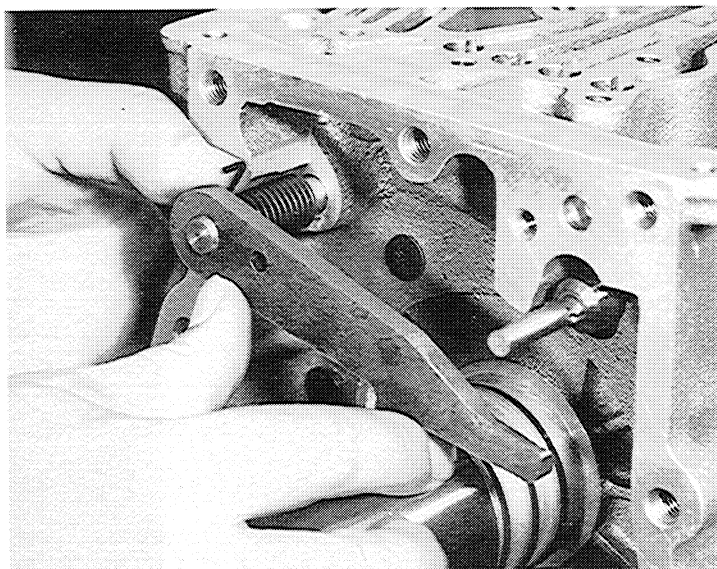

82 118

Install plate 24160 together with guide plate 24164. Use cylindrical bolt 24170 for tightening. (Tool size torx bit 27) (To be torqued 10 Nm.)

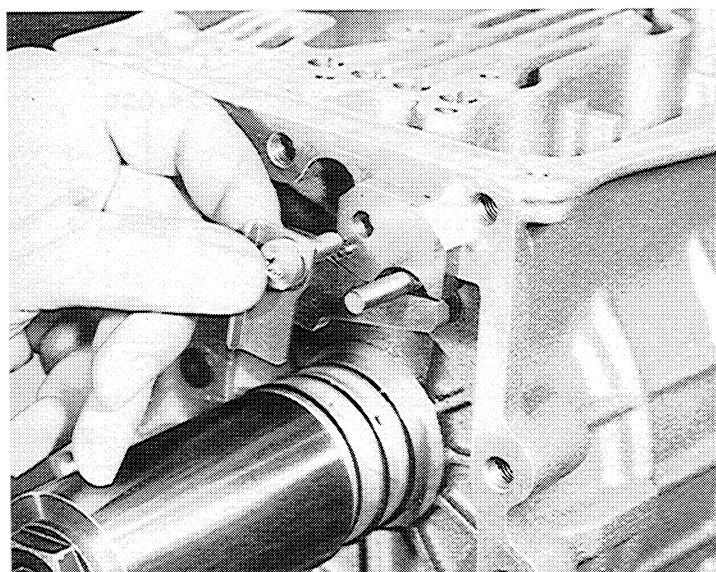

### 3.6 Planetary Set 4th Gear

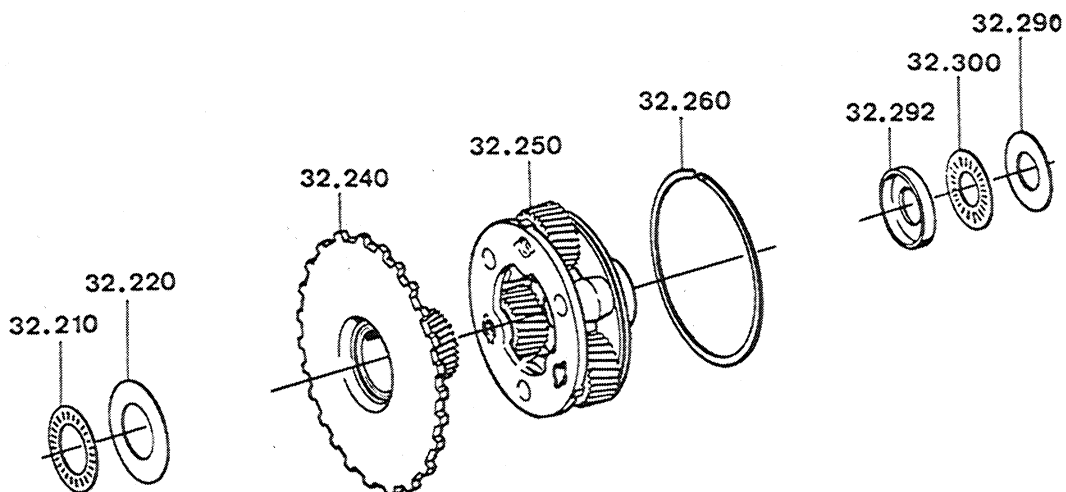

82 123

Turn transmission into vertical position.

Insert disc washer 32290, axle cage 32300 and thrust washer 32292.

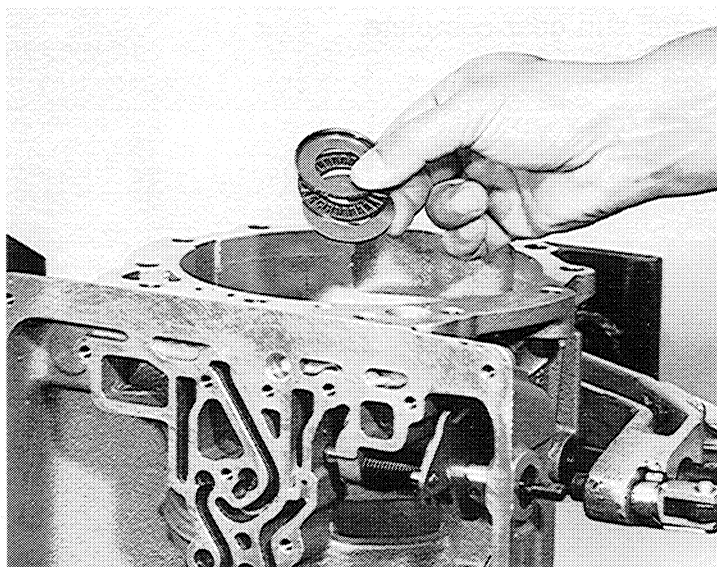

82 124

Install seal ring 32260 onto planetary case and snap together.

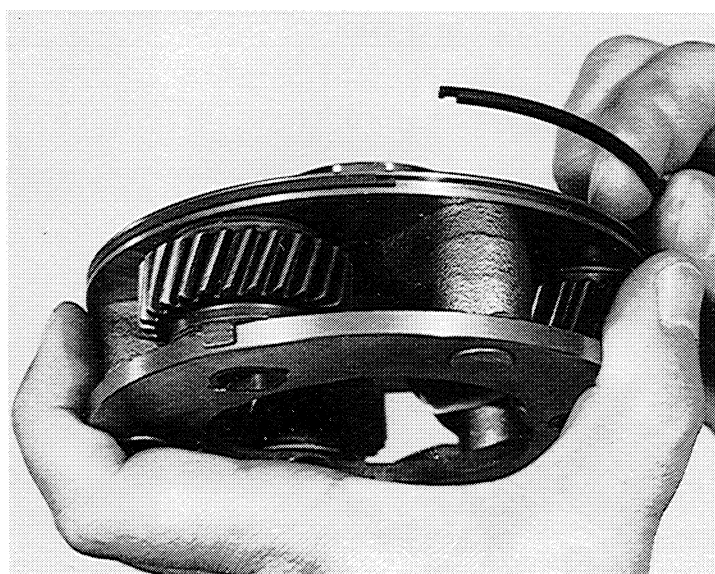

Install planetary set with turning motion into hollow gear.

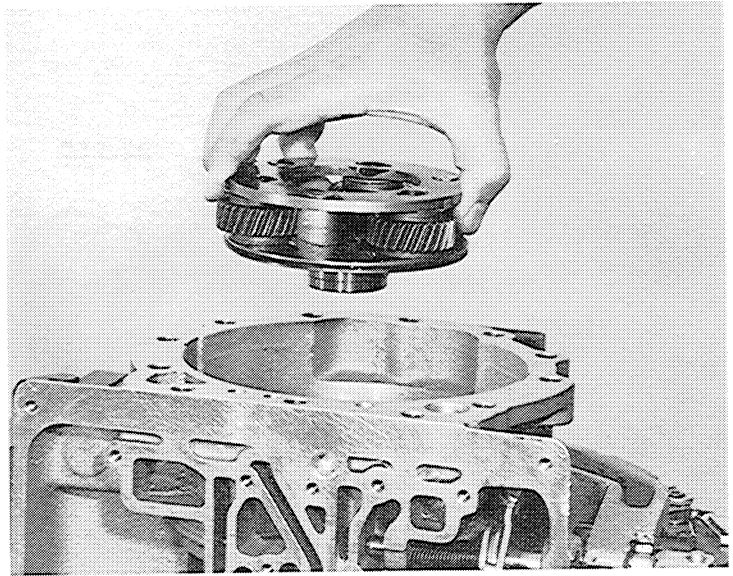

Install sun gear complete.

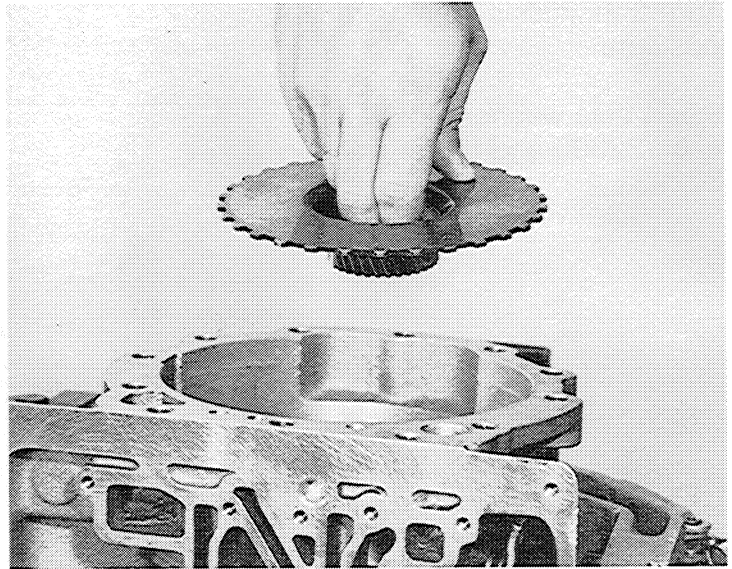

Insert disc 32220 and axle cage 32210.

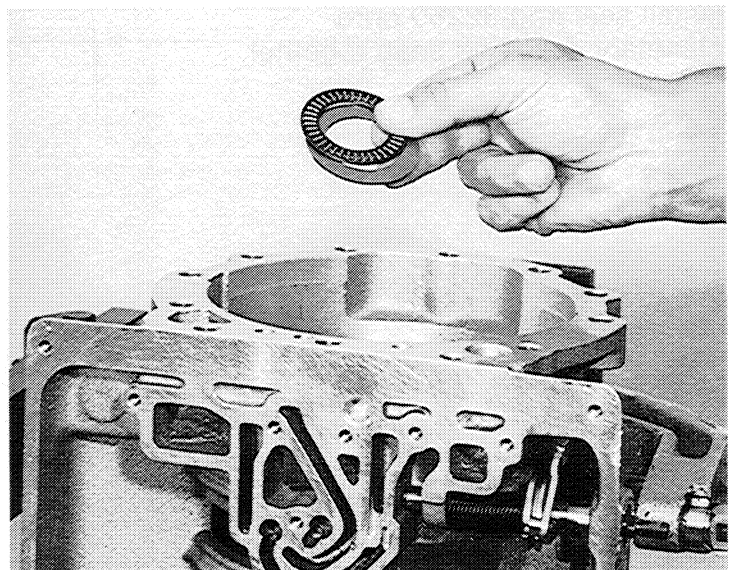

### 3.7 Web Shaft with Planetary Set

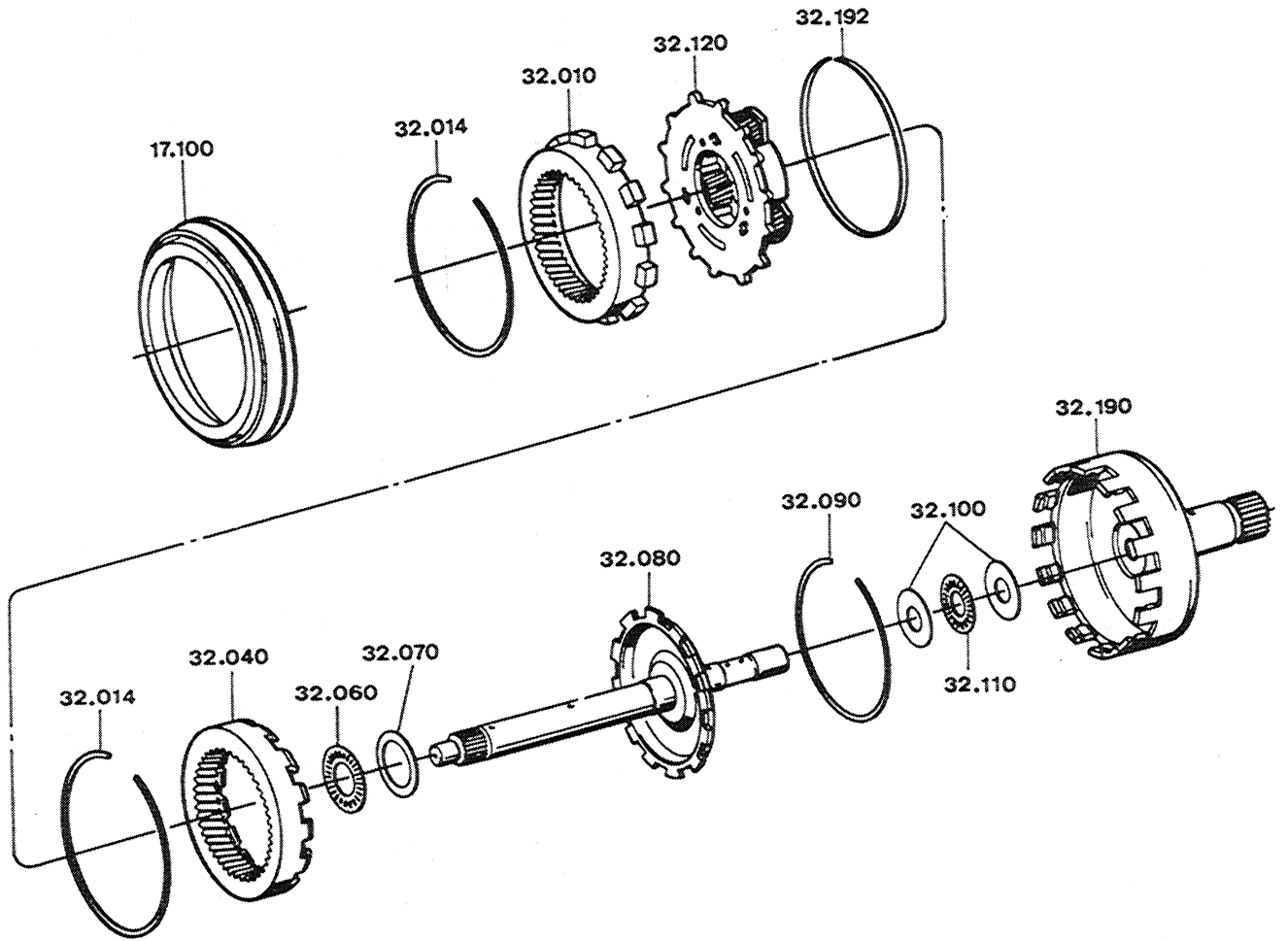

Place web shaft into supporting device (5X56 000 072) and install snap ring 32014 into lower groove.

82 128

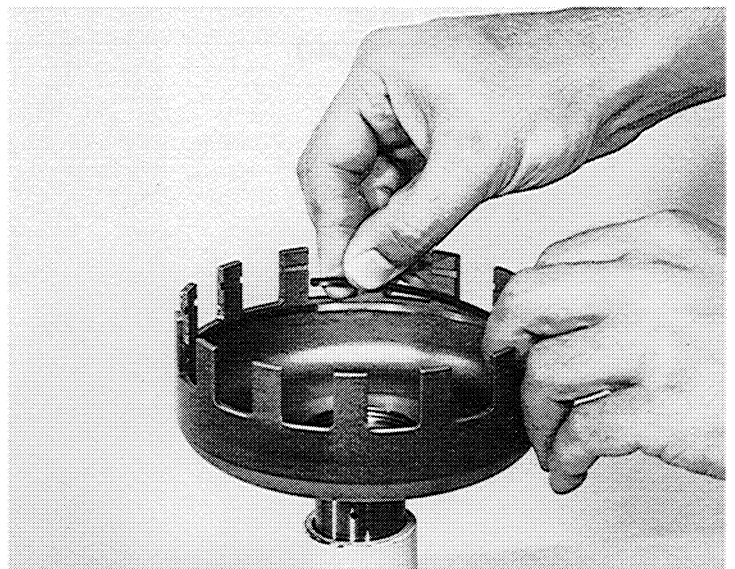



82 058

Install snap ring 32192.

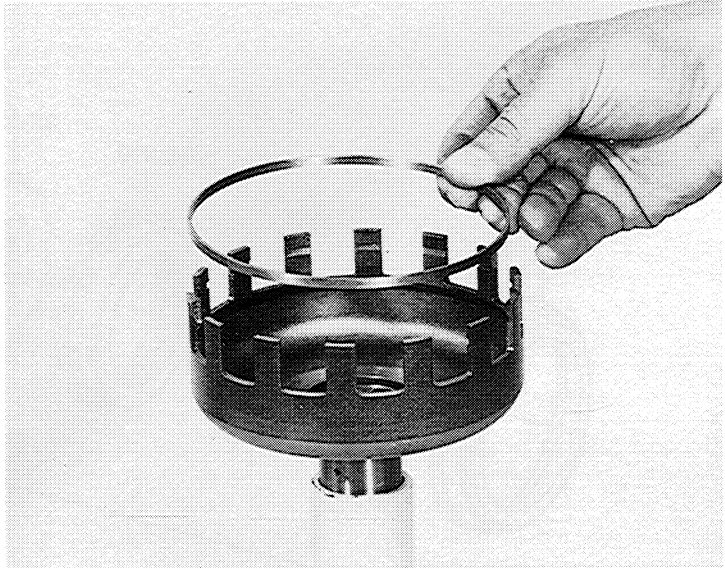

82 129

Insert 1 disc washer 32100 and axle cage 32110.

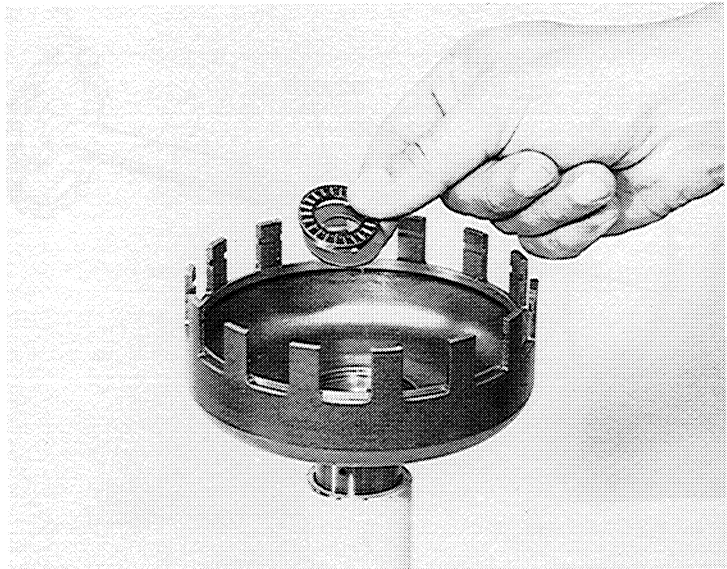

82 059

Connect intermediate shaft 32080 with hollow gear 32040 and secure with snap ring 32090.

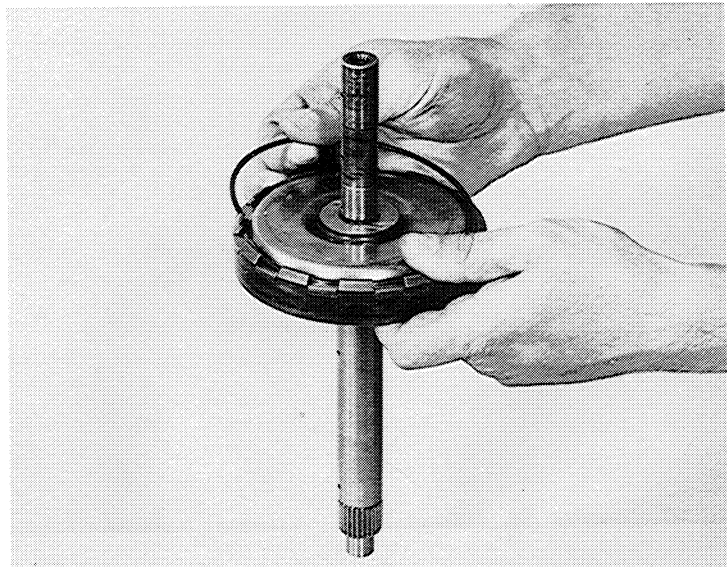

Insert thrust washer 32100  
with grease on intermediate  
shaft.



Install intermediate shaft together  
with hollow gear into web shaft.

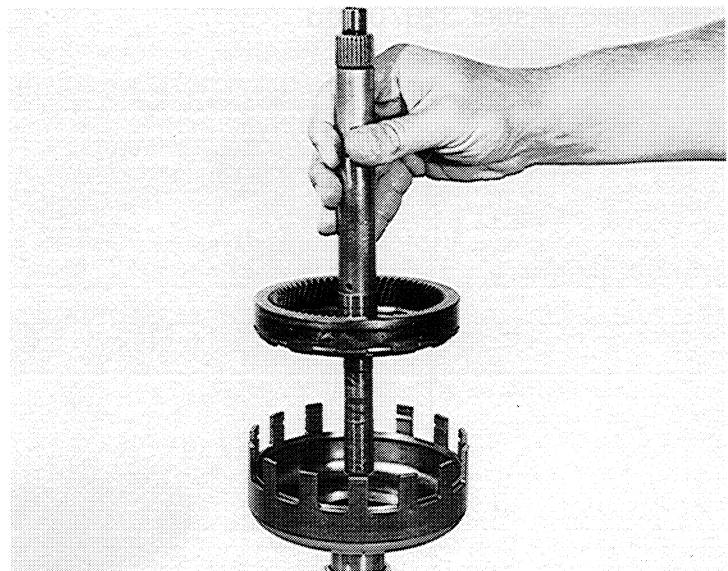

Install with turning motion,  
rear planetary set 32120 complete  
into hollow gear.

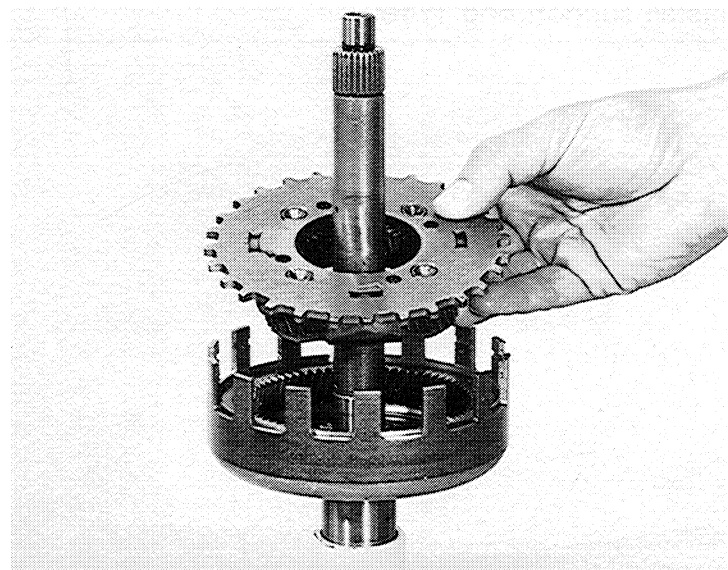

Install front hollow gear 32010  
and secure with snap ring 32014.

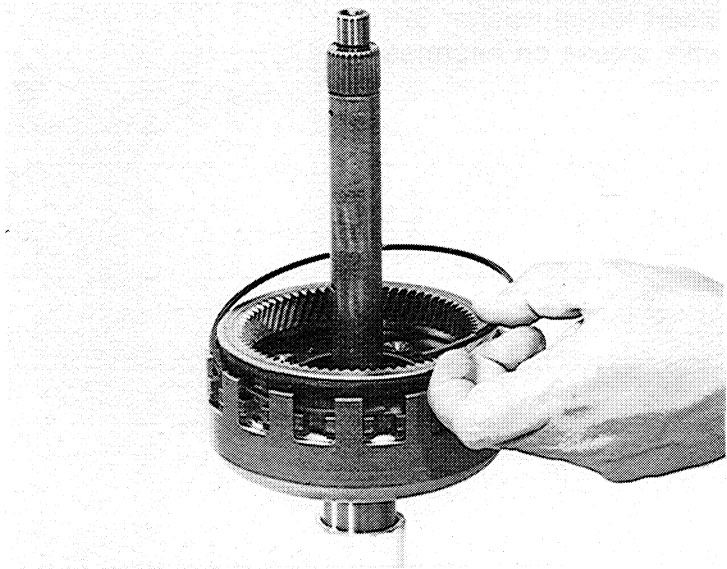

Insert disc washer 32070 and  
seal cage 32060.

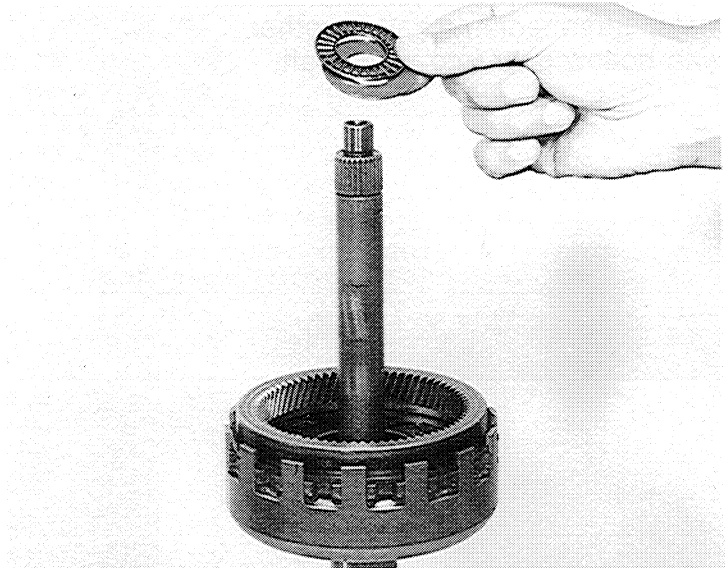

Install support ring 17100.

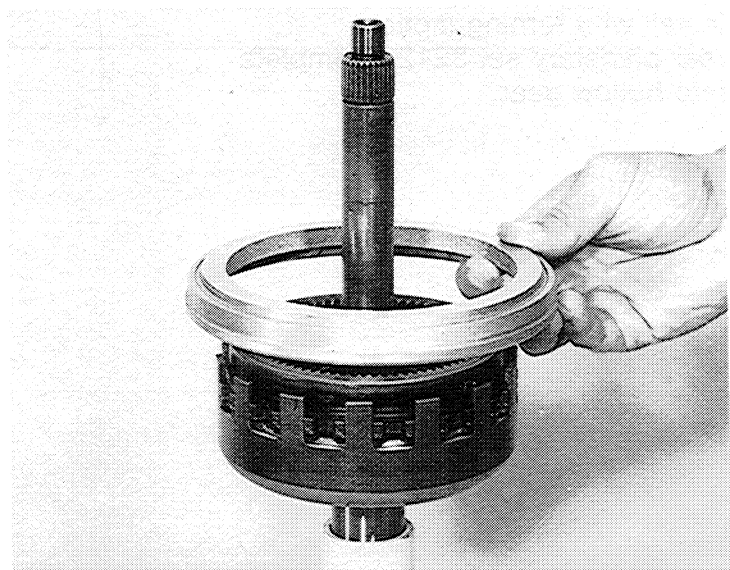

### 3.8 Cylinder C-D

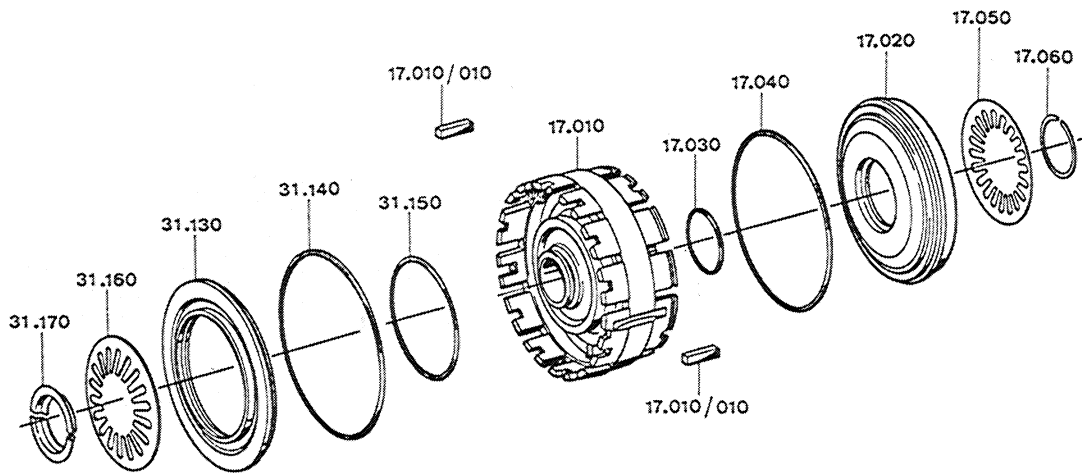

81 157

Tap 2 fitting keys down into slots of cylinder C-D 17010, as shown in the picture.

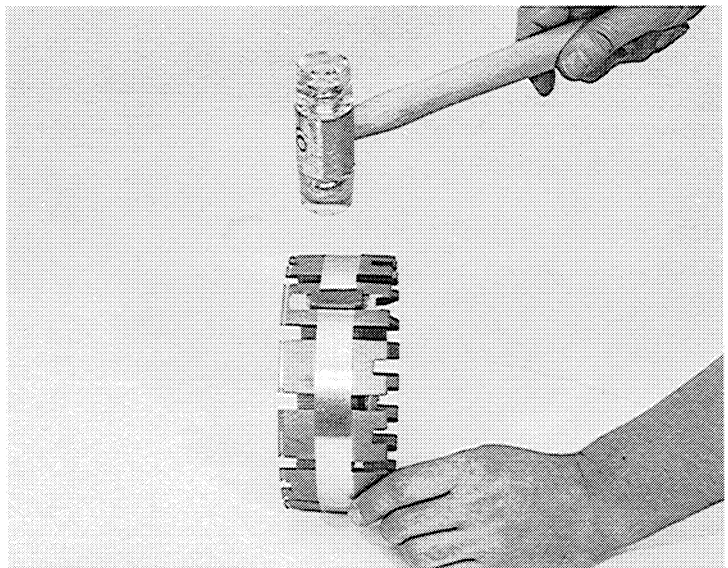

81 158

Insert o-rings 17030 and 17040 onto piston D 17020.

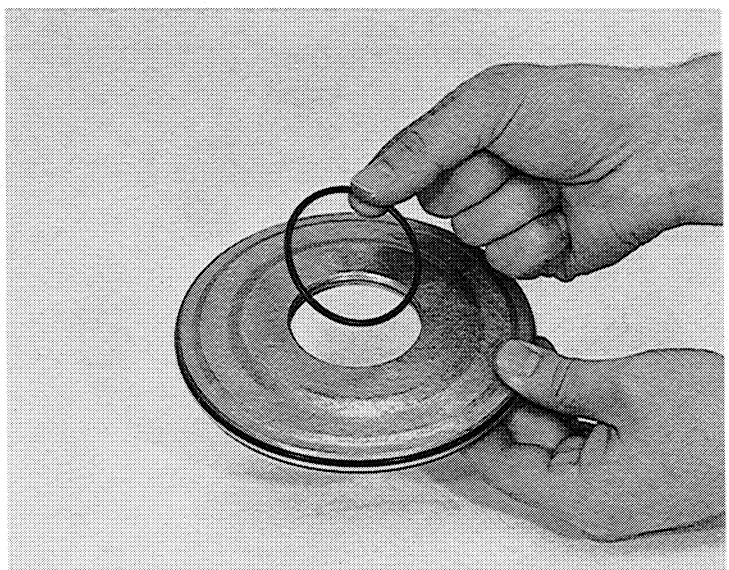

Install piston D into cylinder C-D as shown in the picture. For easy mounting of o-rings use light grease (Vaseline).

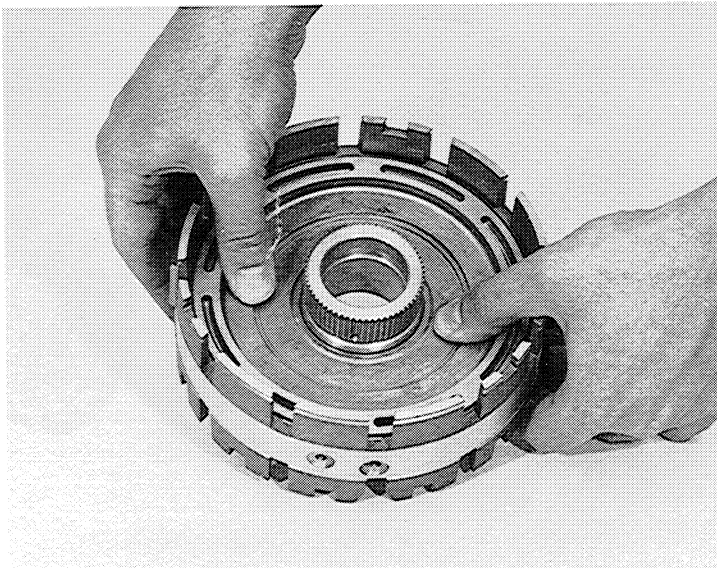

Place plate spring 17050 into piston D. Insert mounting sleeve (5X56 000 058) on top of spring. Insert snap ring 17060 on tapered sleeve seat.

Use outside part of mounting sleeve and press snap ring downward into groove.

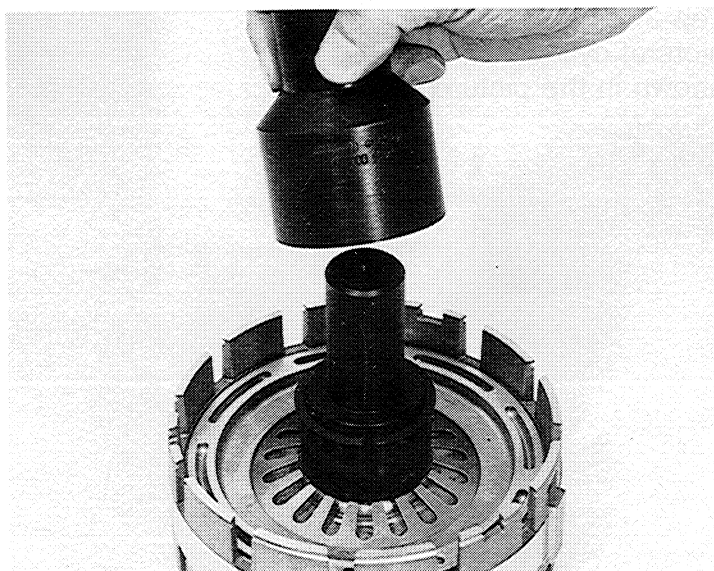

Install piston C 31130 with o-ring 31140 and 31150 in the same manner as piston D. Insert plate spring 31160 on top of piston C and use spring device (5 X 56 000 093) to press plate spring downward and insert split rings 31170 as shown in the picture.

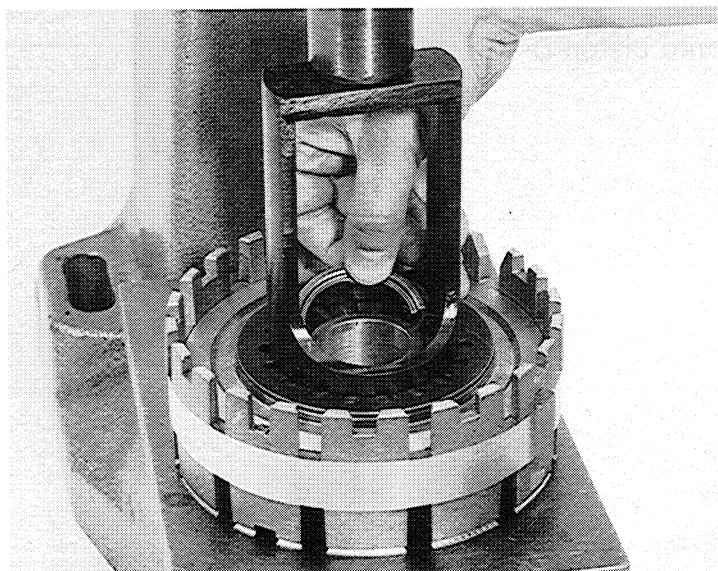



### 3.9 Brake D with Freewheel First Gear

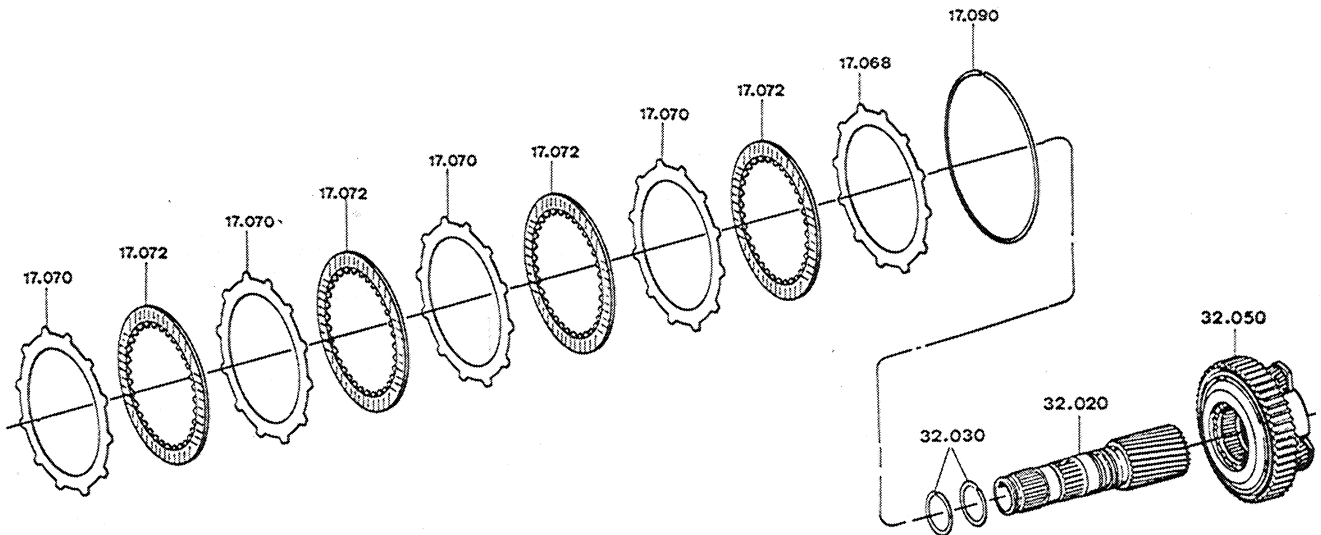

82 133

Install planetary set 32050 with freewheel 1st gear on hub of cylinder C-D.

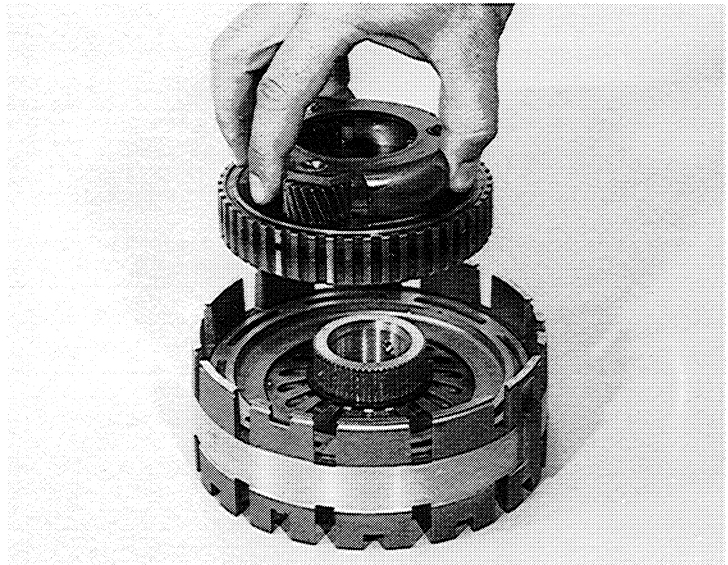

82 134

Insert Brake D assembly complete. First start with steel plate 17070, second use clutch plate 17072 alternately.

On top of brake D assembly use thin end plate 17068.

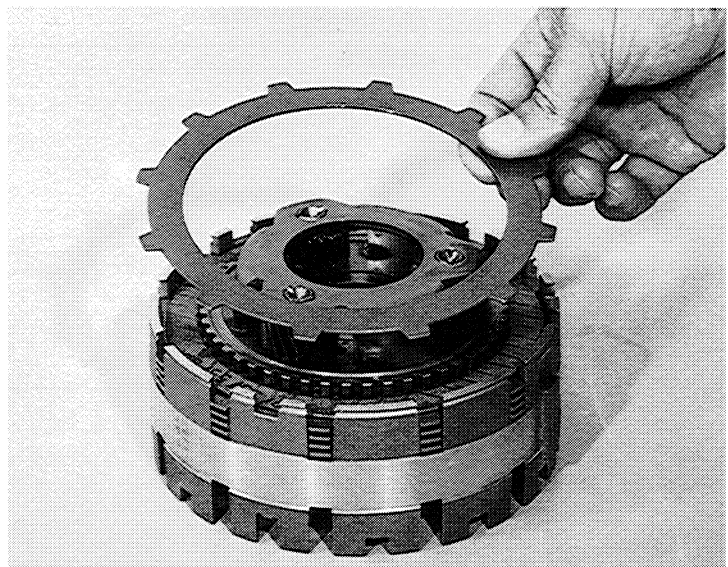

Secure brake D assembly with snap ring 17090.

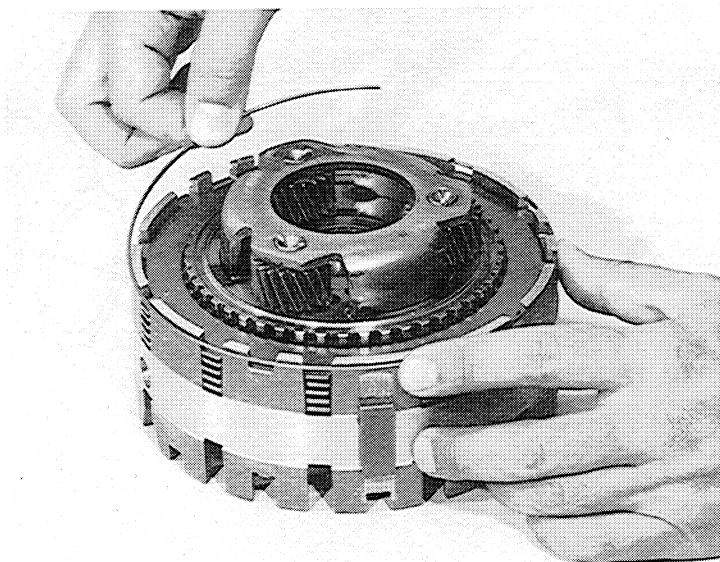

Install 2 seal rings 32030 on sun shaft and snap together.



Install sun shaft into planetary set as shown in the picture.

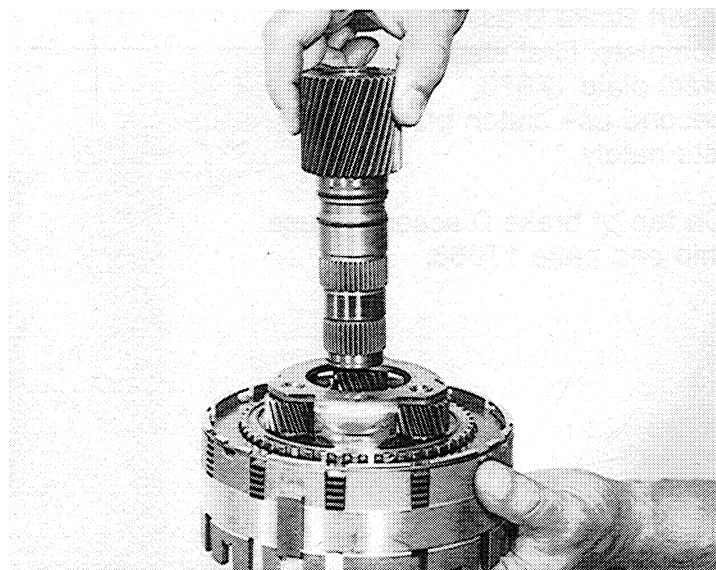

Turn brake D assembly right side up together with sun shaft and fit into planetary set.

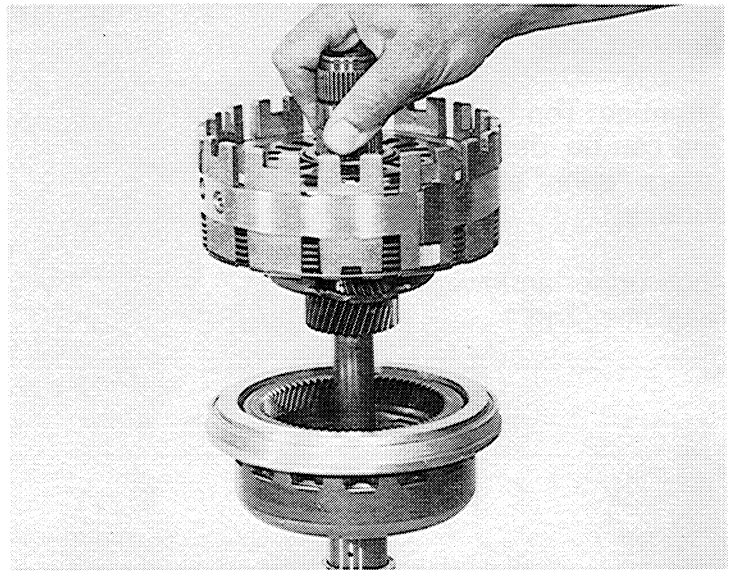

### 3.10 Brake C-C'

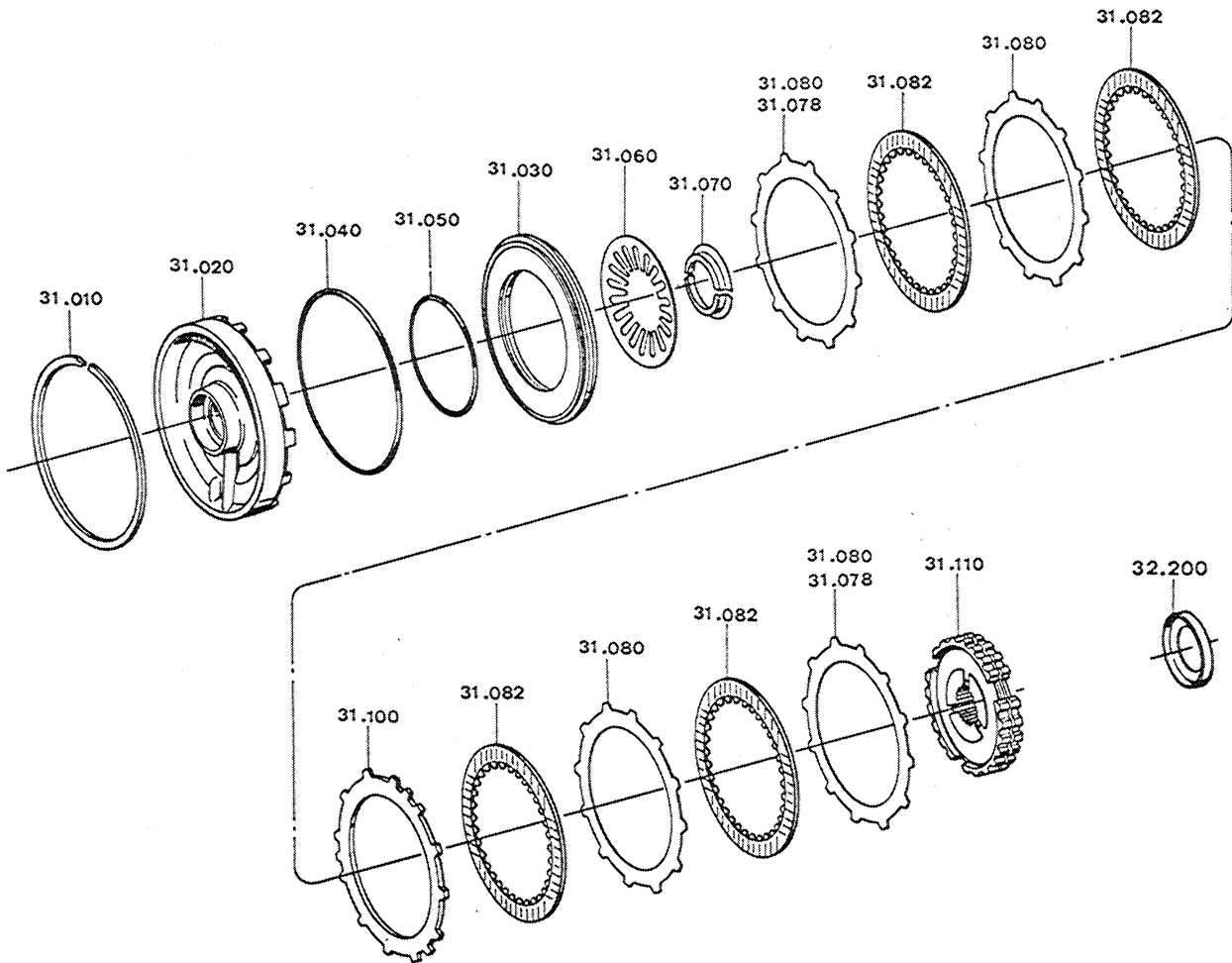

Install freewheel 2nd on sunshaft seat.

**Attention:** Top of freewheel 2nd can be identified by the letters "oben" stamped to surface.

Align upper and lower halves of freewheel 2nd.

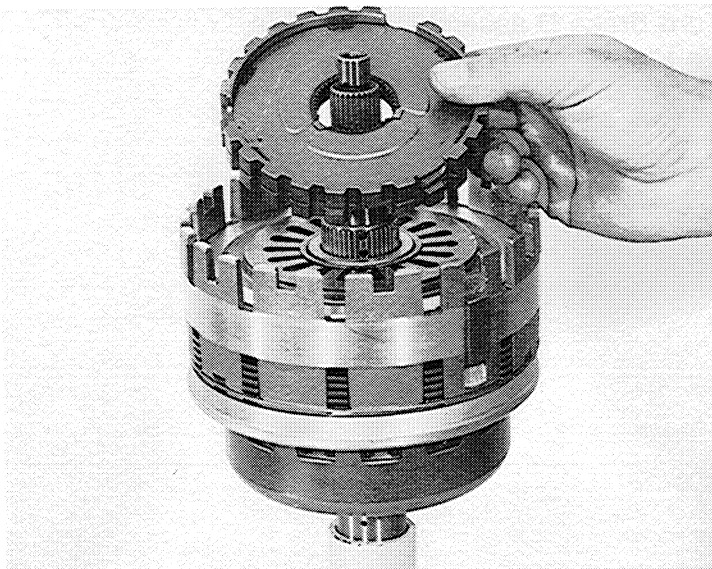

Insert brake C assembly and start with steel plate 31080, alternating clutch plate 31082 and 31080.

Install end plate of brake D assembly, narrow gap teeth of end plate must fit onto tabs in cylinder C-D shown in the picture.

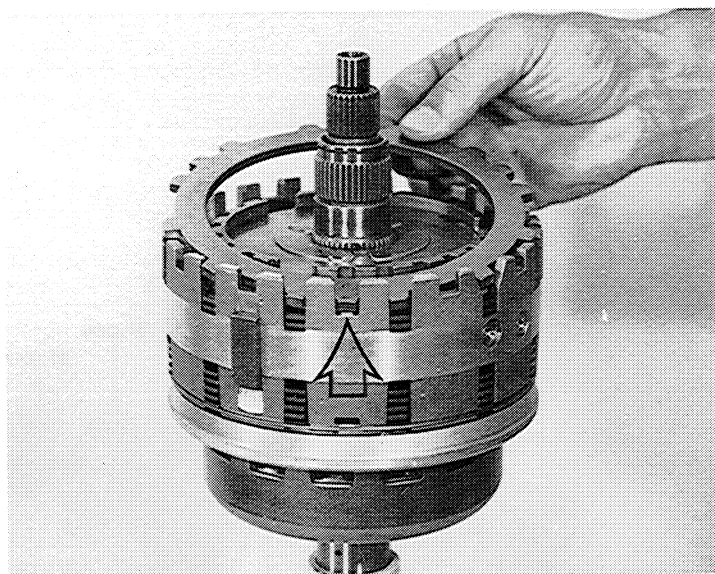

Insert brake C' assembly, and start with clutch plate 31082.

Be careful not to insert outer teeth of steel plate into V-shaped area of cylinder C-D as shown in the picture.

**Attention:** If it is necessary to insert steel plates 31078 into brake C and C' assembly.

Thin steel plates must be always facing to piston side. Dependent to transmission part number.

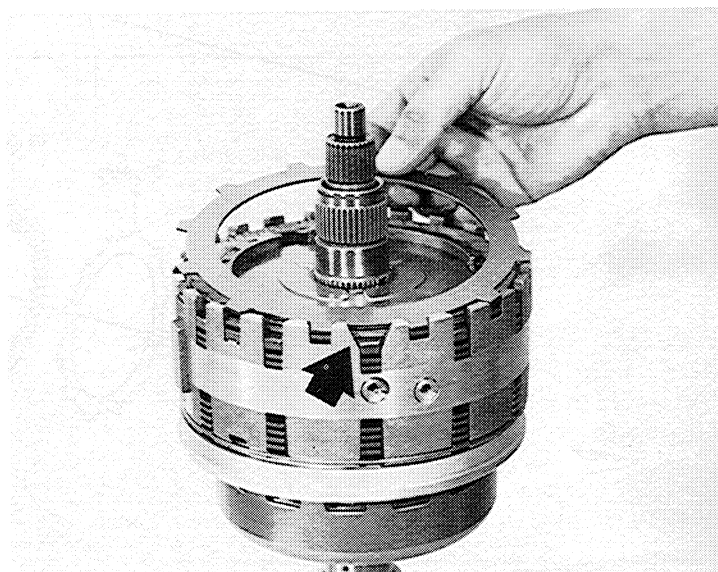

Insert o-rings 31040 and 31050 onto piston C' 31030. Install piston C' complete with o-rings into center plate 31020.

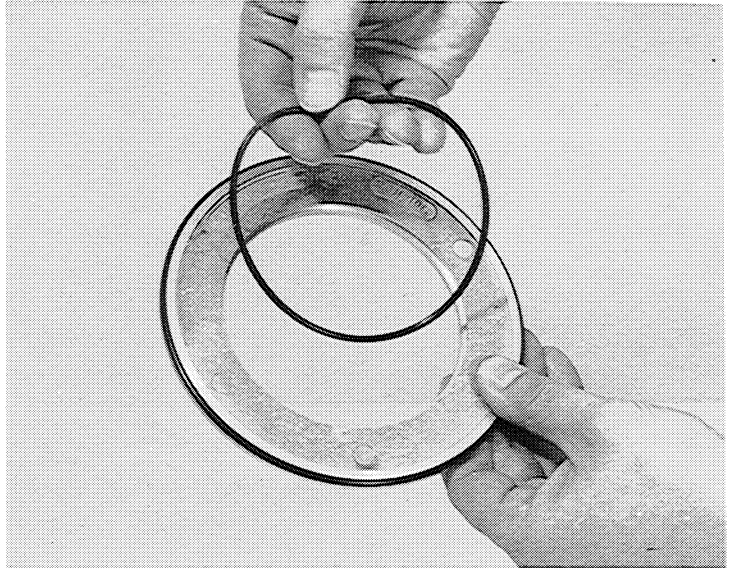

Install plate spring C' 31060 with spring device (5 X 56 000 093) and secure with split rings 31070.

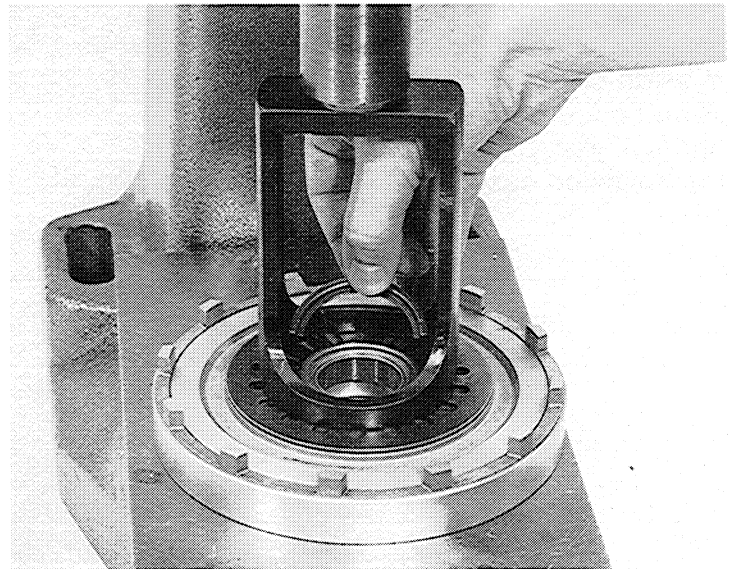

Insert largest tap of center plate assembly into V-shaped area of cylinder C-D, as shown in the picture.

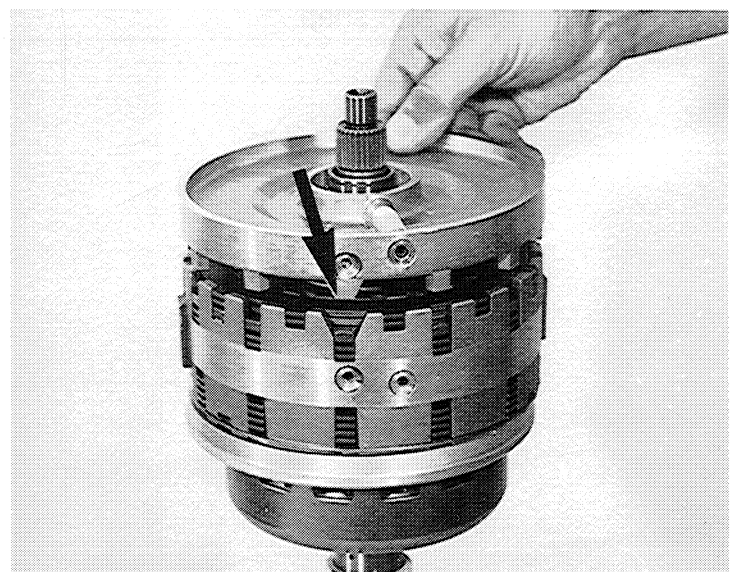



Remove C, C' and D clutch assembly complete from supporting device. Also insert thrust washer 32200 with Vaseline onto web shaft seat.

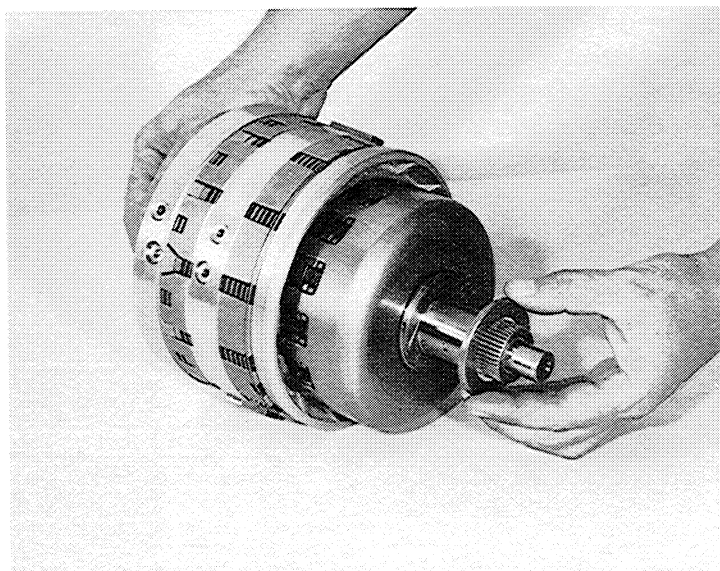

Install C, C' and D clutch assembly complete into transmission case.  
Align oil feed holes in center plate and cylinder C-D with holes in transmission case.

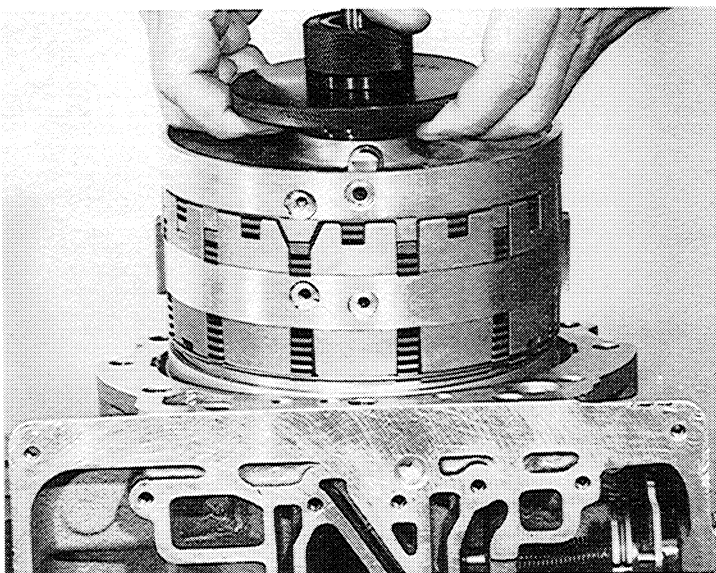

Secure center plate with snap ring 31010.

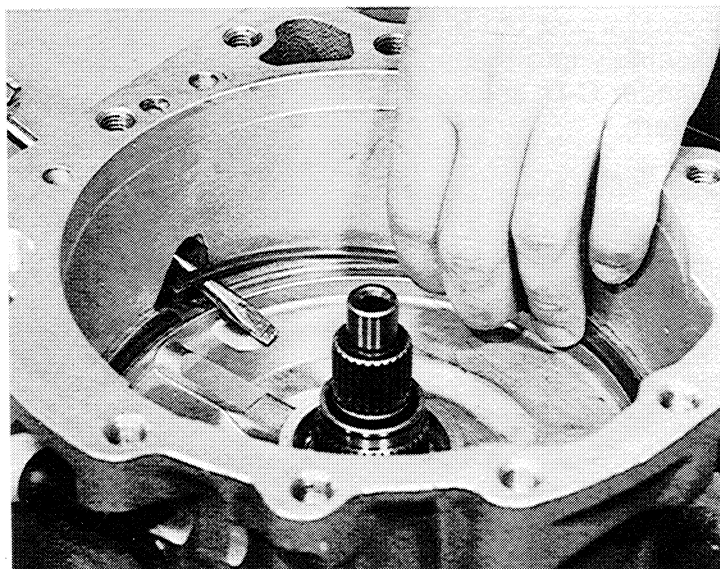

### 3.11 Clutch B

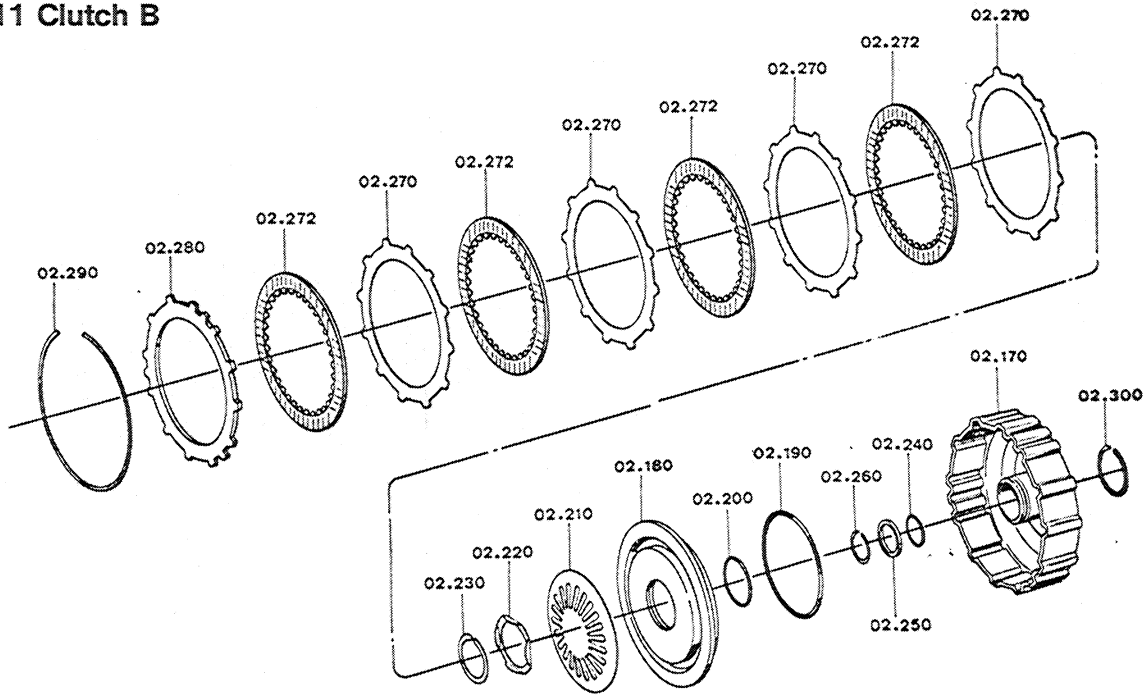

81 139

Fit o-ring 02190 into piston B  
02180  
Fit o-ring 02200 into cylinder B  
02170.  
Install piston B together with  
o-ring into cylinder B.

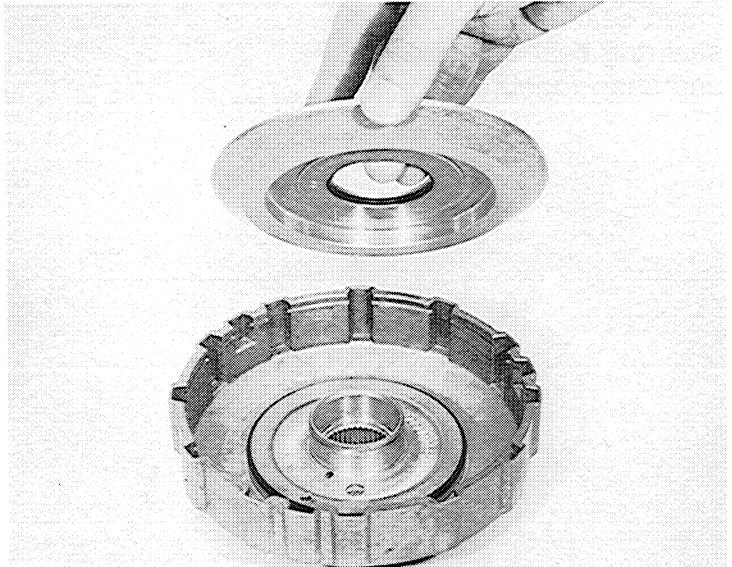

81 140

Install plate spring, next install  
security washer.

Insert snap ring 02230 on tapered  
sleeve seat (5X56 000 092).

Use outside part of mounting  
sleeve and push snap ring  
downward into snap ring.

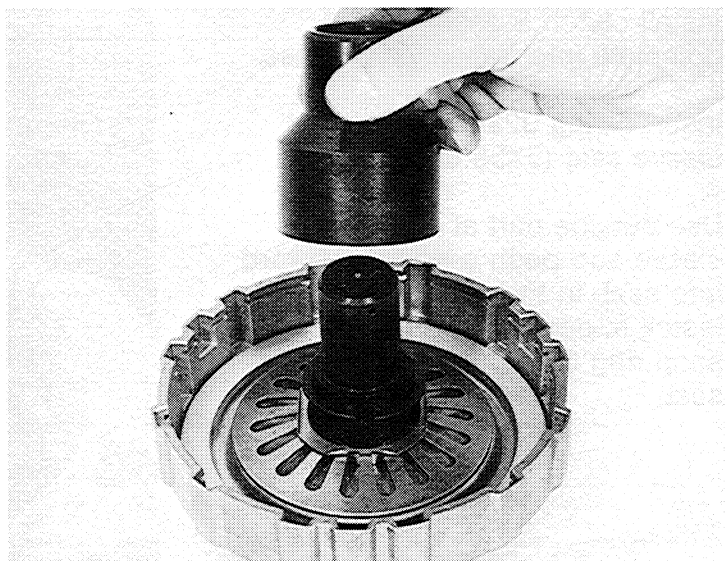

Install clutch B assembly,  
start with steel plate 02270.  
Alternately, use  
clutch plate 02272  
steel plate 02270

Secure end plate 02280 with  
snap ring 02290.

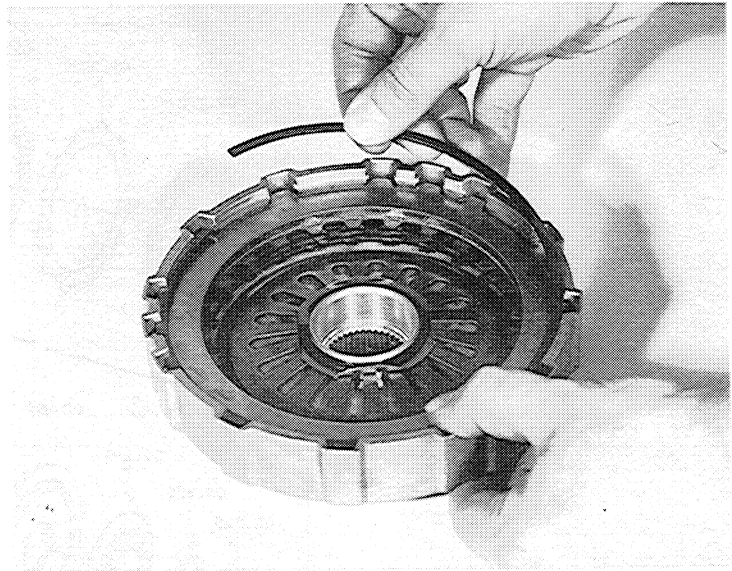

Insert seal ring 02300 into  
seal ring seat on cylinder B  
and snap together.

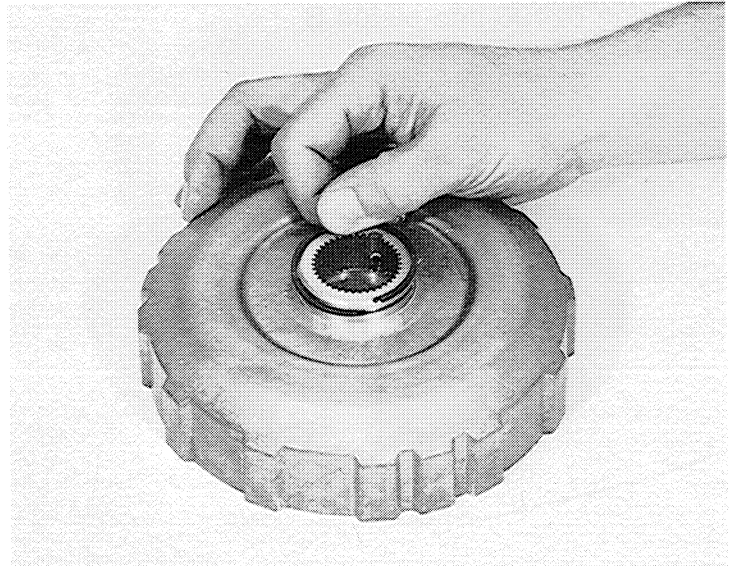

Install clutch B assembly  
complete into transmission case.

Insert o-ring 02240 on tapered  
sleeve seat (5X56 000 075).

Use outside part at mounting  
sleeve and push o-ring downward  
into seat. In the same manner,  
install support ring 02250 and  
snap ring 02260 together into  
seat.

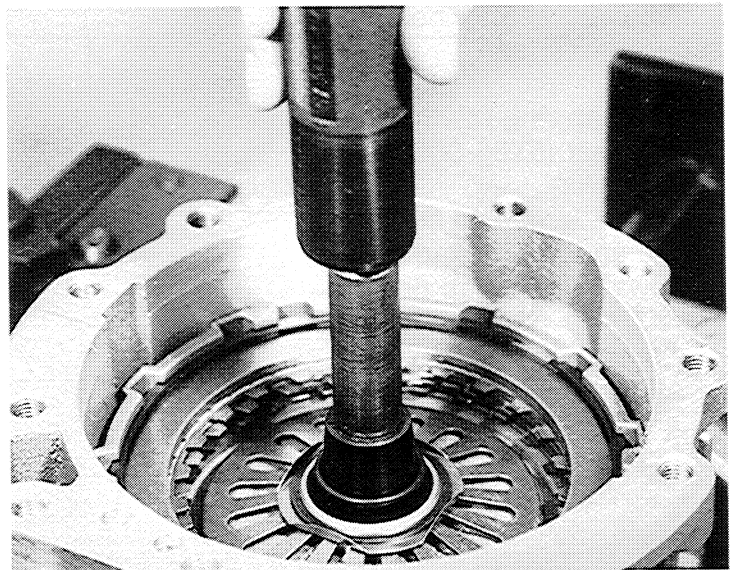

### 3.12 Clutch A

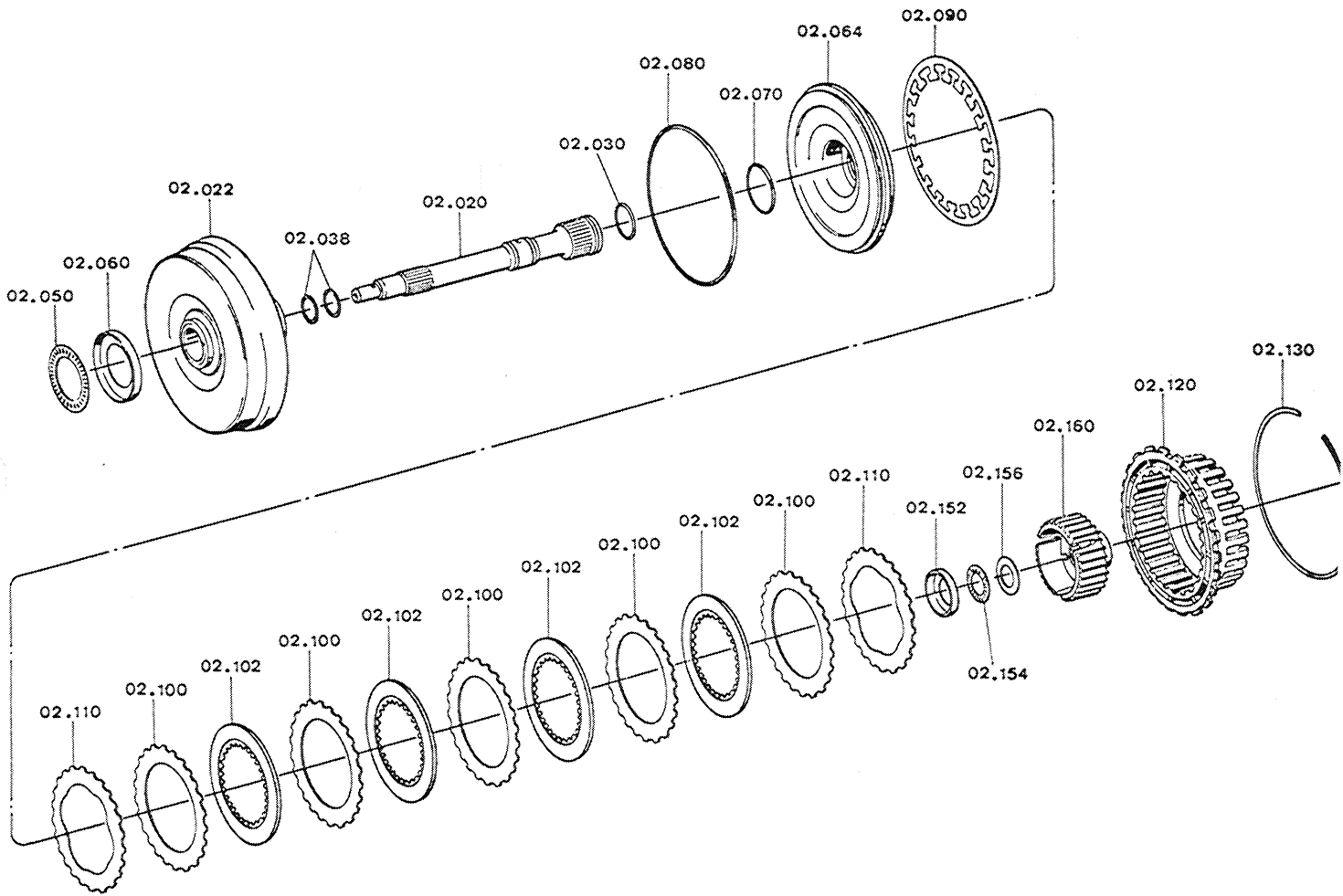

Insert o-ring 02070 and 02080 on piston A 02064. Install piston A together with o-rings into cylinder A.

82 199

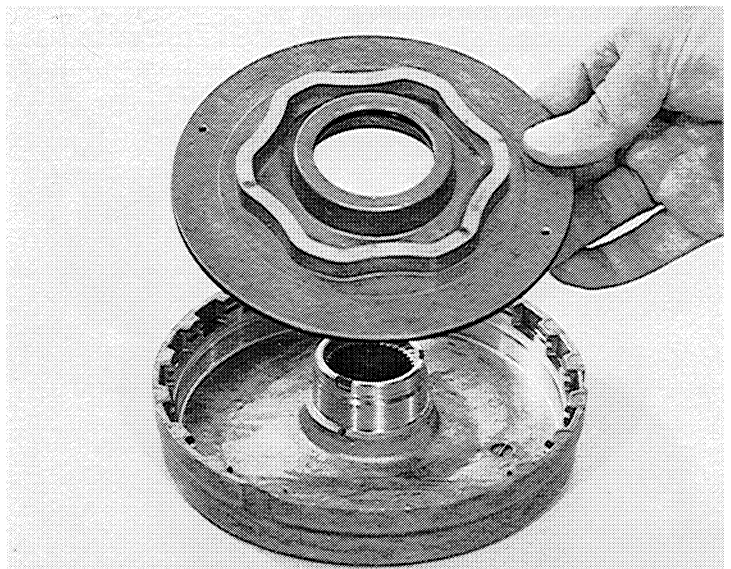

Insert plate spring 02090 on top at piston A.

Convex side of spring plate must be facing to the piston.

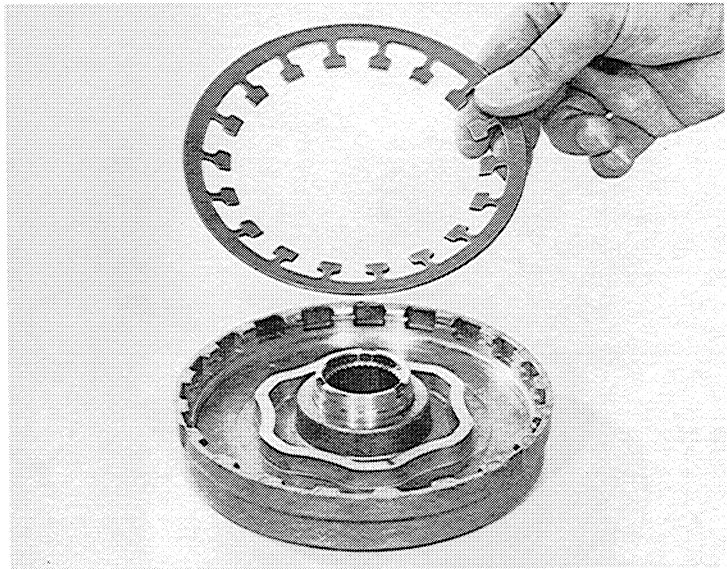

Install clutch A assembly complete.

**Attention:**

Order of plates -

Start with

spring plate 02110  
steel plate 02100  
clutch plate 02102

Finish with

clutch plate 02102  
steel plate 02100  
spring plate 02110

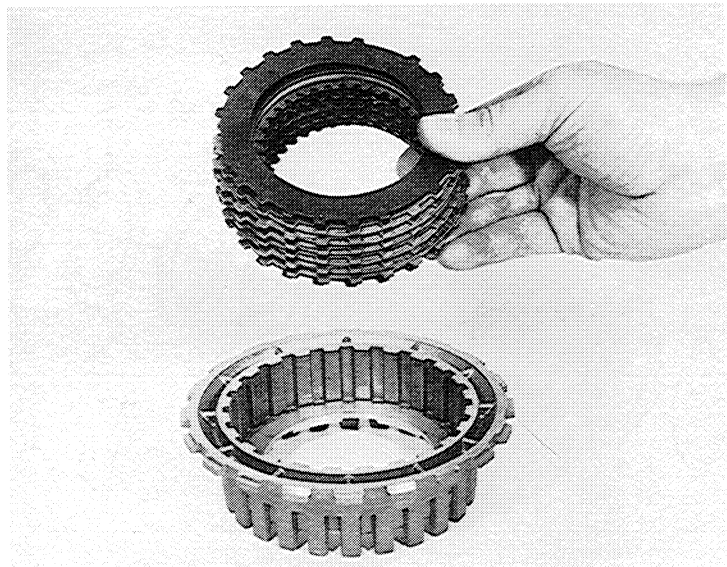

in between use alternating clutch and steel plates.

Install carrier A-B with clutch A assembly into cylinder A.

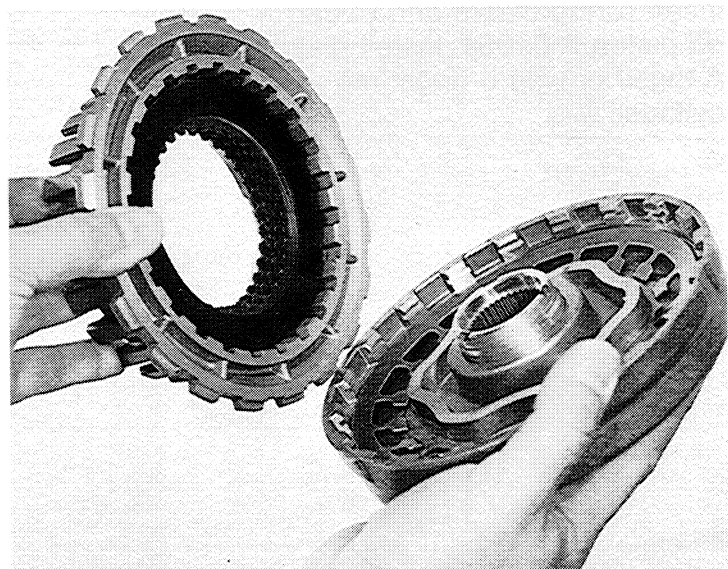



With flat plate (5 X 56 000 094) press carrier A-B downward and secure with snap ring 02130.

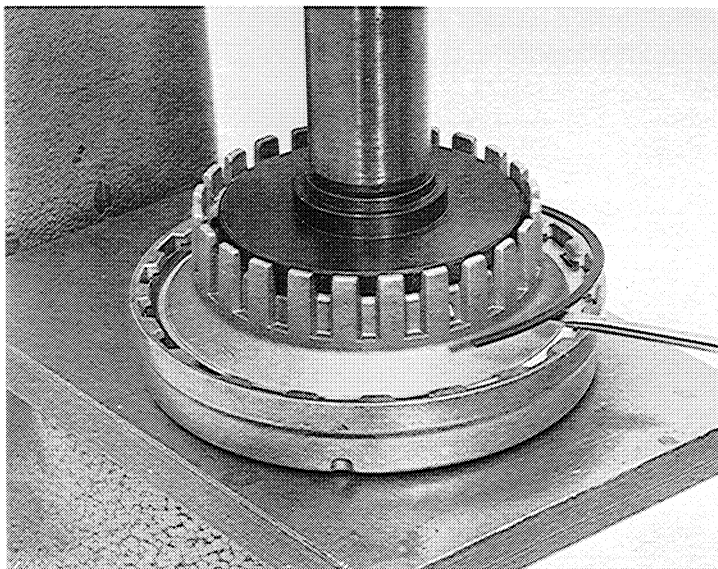

Install 2 seal rings 02038 and 1 o-ring 02030 onto input shaft 02020.

Install input shaft into seat at cylinder A assembly. Press input shaft downward to stop point.

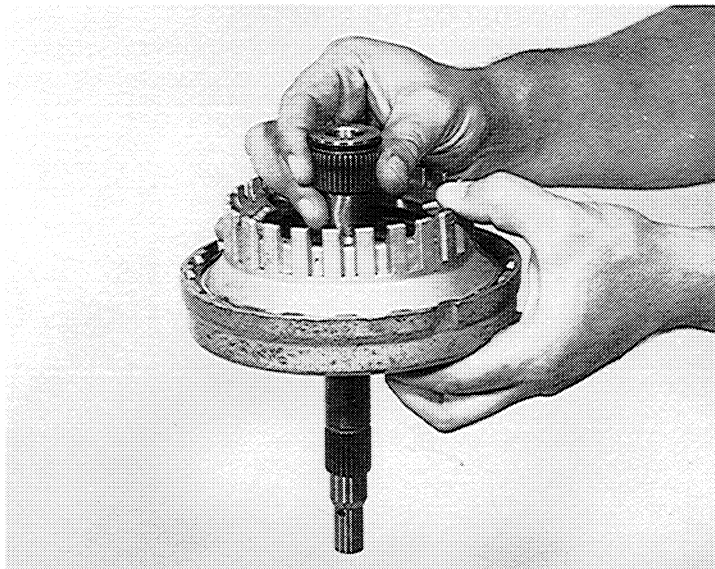

Insert thrust washer 02152 with vaseline on input shaft seat as shown in the picture.

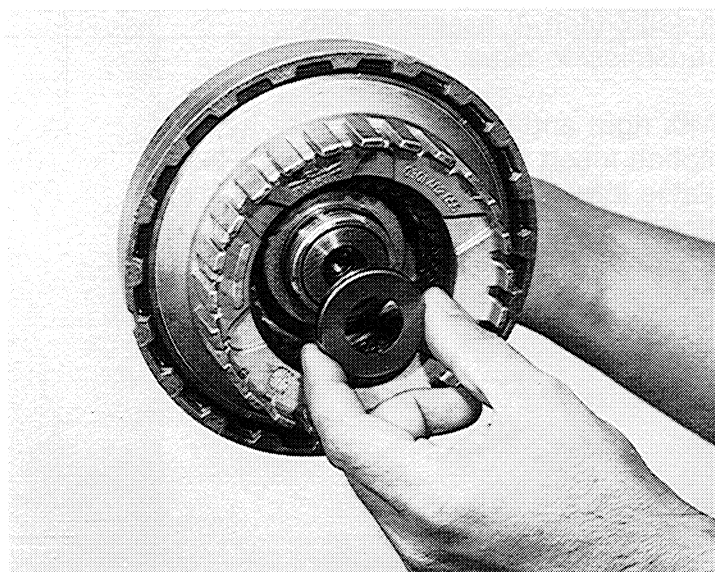

Install inner carrier A 02160  
onto intermediate shaft seat.

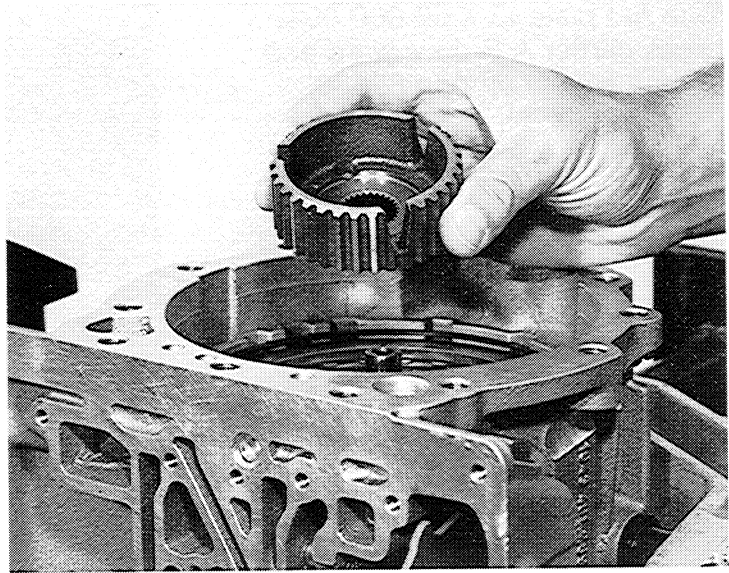

Insert disc washer 02156 and  
axle cage 02154.

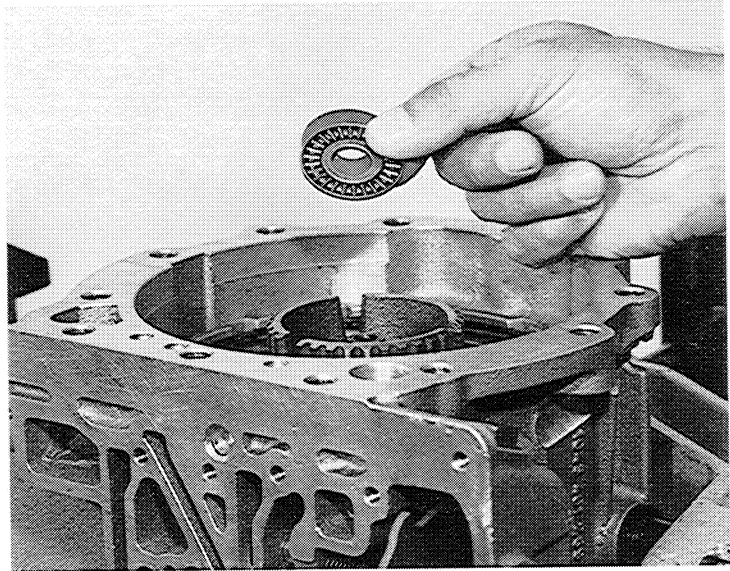

Install clutch A' assembly into  
transmission case.

With right and left twisting  
motion insert teeth from clutch  
plates into carriers A-B and  
inner carrier.

Top of cylinder A assembly  
should not exceed 8.5 mm  
above transmission case.

For measuring use caliber.



Insert thrust washer 02060 and axle cage 02050 into seat at cylinder A.

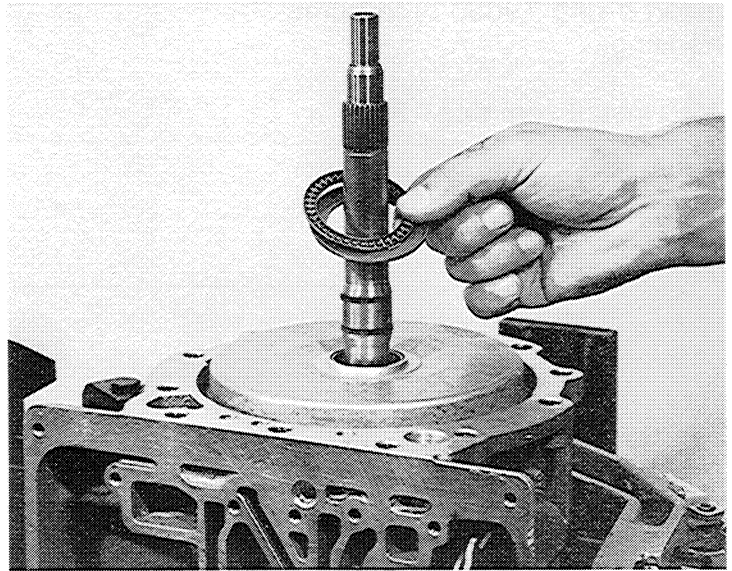

### 3.13 Pump, Intermediate Plate and Bell Housing.

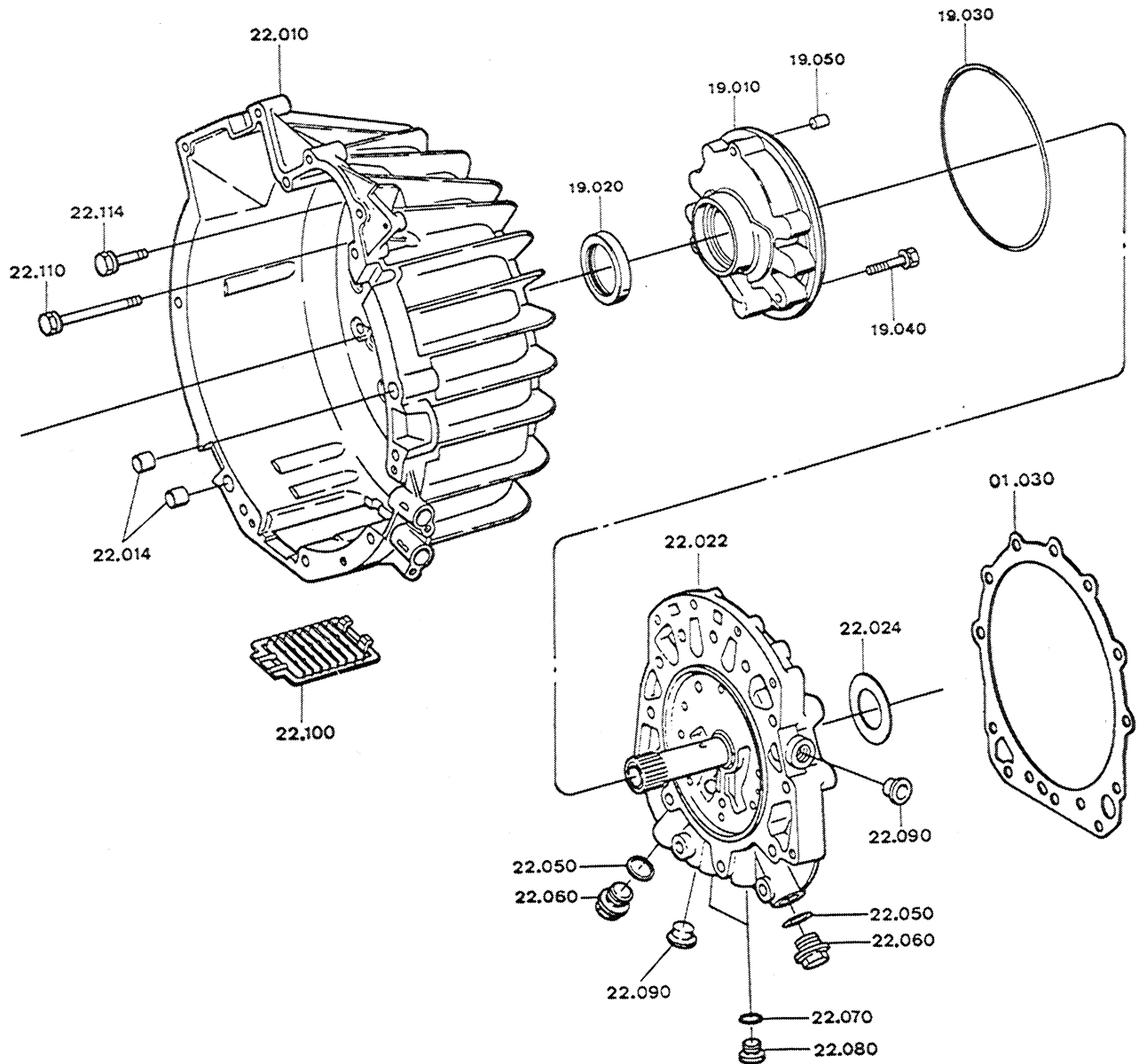

Insert o-ring 19030 onto pump housing.

Also install seal ring 19020 with mounting sleeve (5 X 46 000 069) as shown.

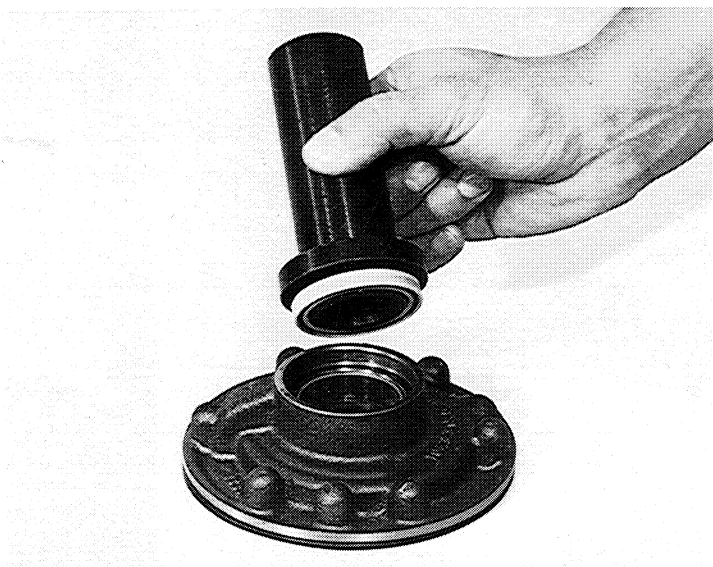

Install pump 19010 hollow gear and pump gear into pump housing with marked side of gears facing upwards.

Tap alignment pin into pump housing.

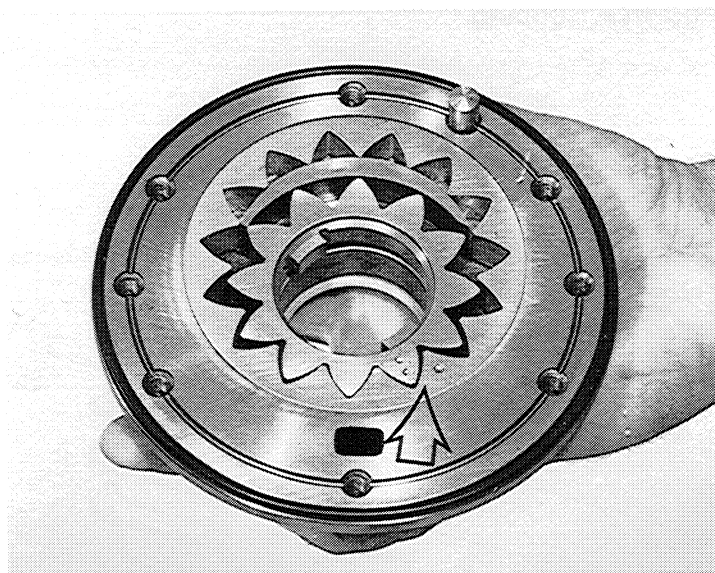

Insert pump into intermediate plate 22022 and secure with 8 hexagon bolts 19040.

(To be torqued 10 Nm)  
(Tool head size = 10 mm)  
If a new intermediate plate is to be used, install sealing plugs with washers.

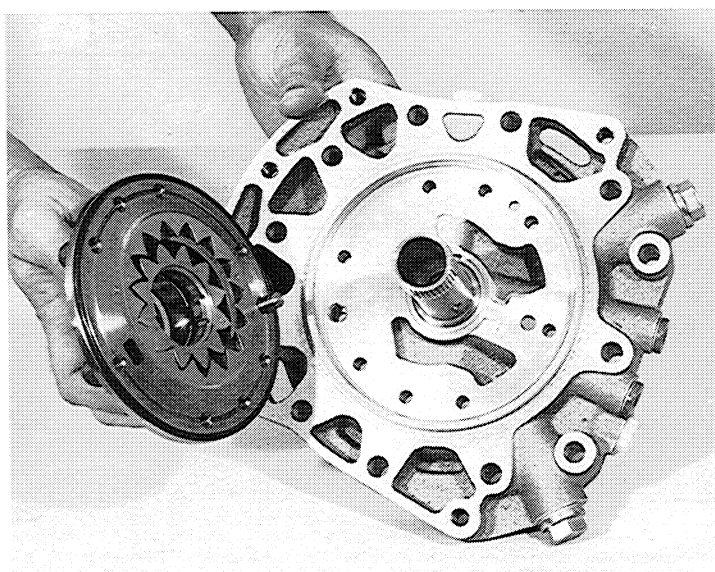



To check ease in rotation of pump gears use sleeve (5 X 56 000 021).

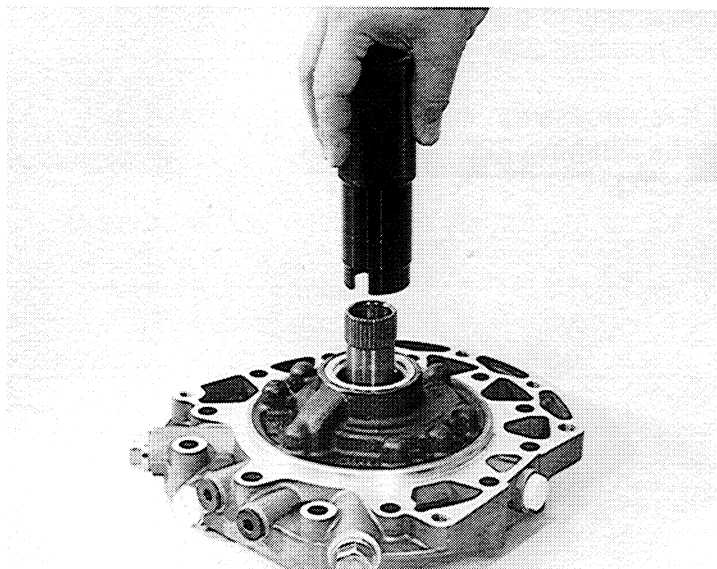

Insert gasket 01030 and disc washer 22024 with vaseline onto intermediate plate.

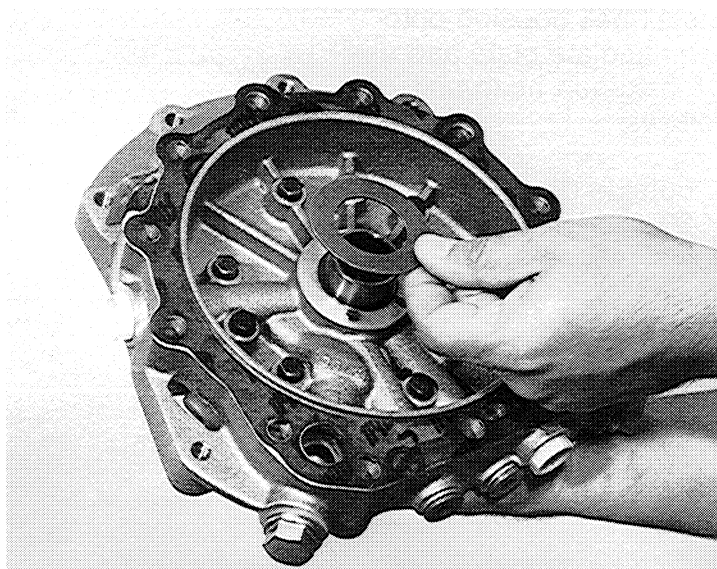

Use vaseline on seal rings of input shaft.

Install intermediate plate assembly on transmission case.

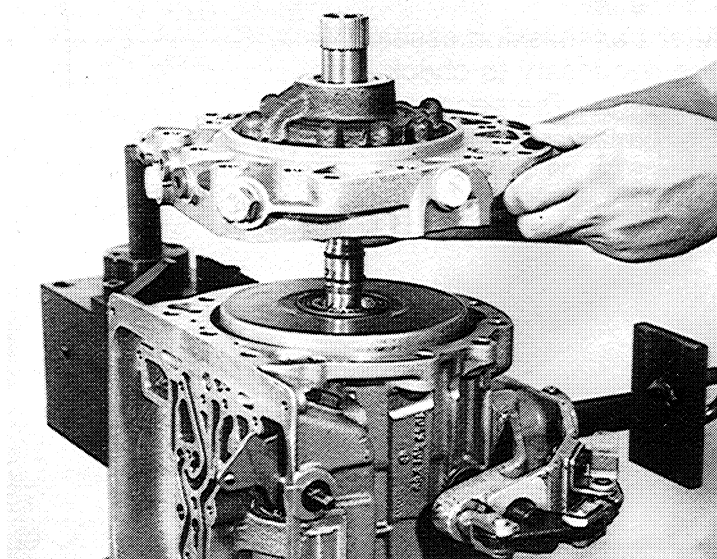



Install plastic grill 22100 onto bell housing 22010.

If it is necessary, install guide bushing 22014 into bell housing.

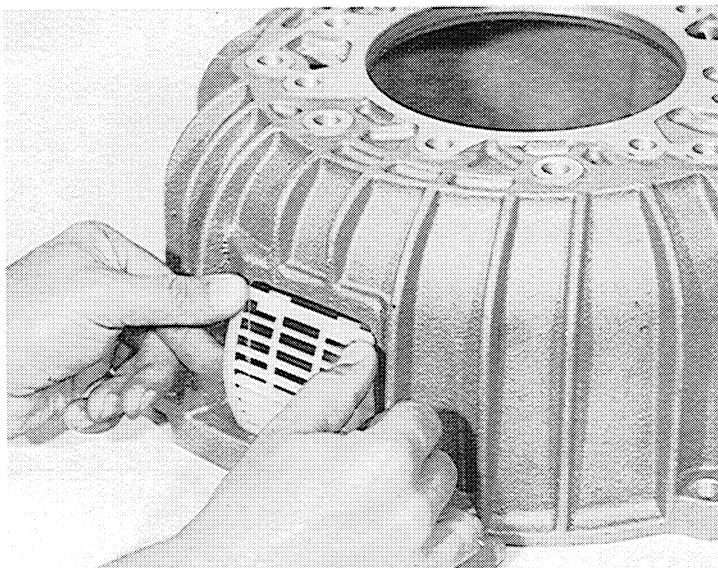

Install bell housing onto intermediate plate and use 18 hexagon head bolts as follows.

outside diameter 6 bolts  
30 mm length - 022 114  
inside diameter 12 bolts  
70 mm length - 022 110

(To be torqued 46 Nm)  
Tool head size = 17 mm.

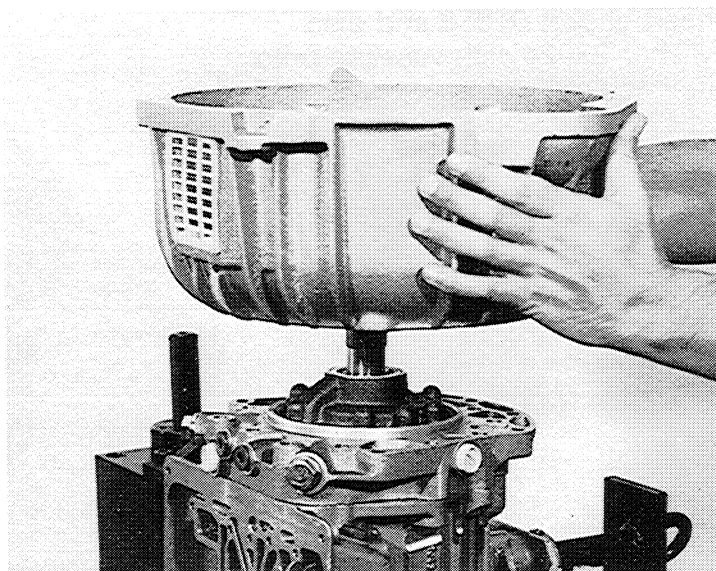

**Attention:**

After transmission assembly, it is necessary to check axle clearance. The necessary steps are explained under point 1.4.2 Page 5/2.

### 3.14 Governor and Transmission Extension.

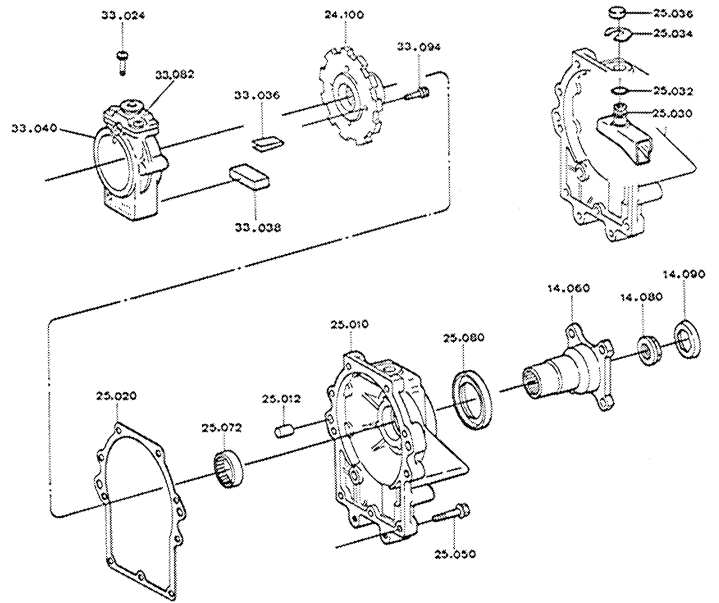

82 159

Picture show governor housing in order to be assembled.

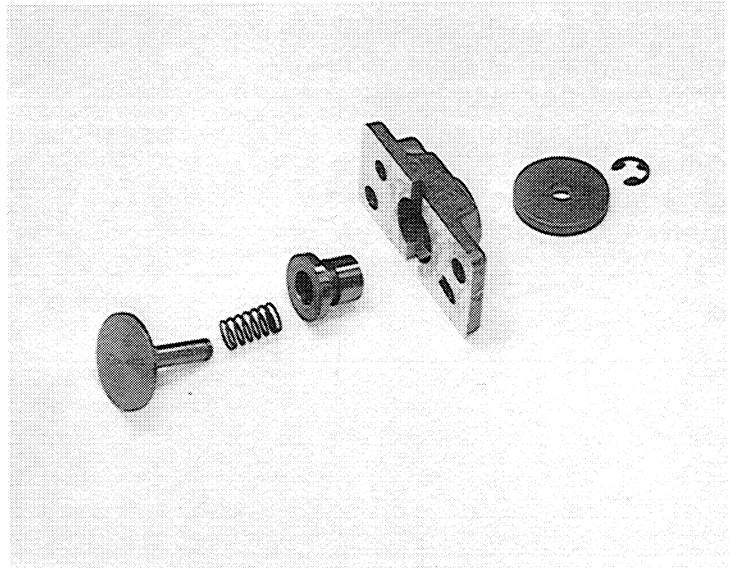

82 160

Assemble governor housing with pin, spring and piston. Insert also weight, and secure with E clip 33070.

**Attention:** always use a new E clip.

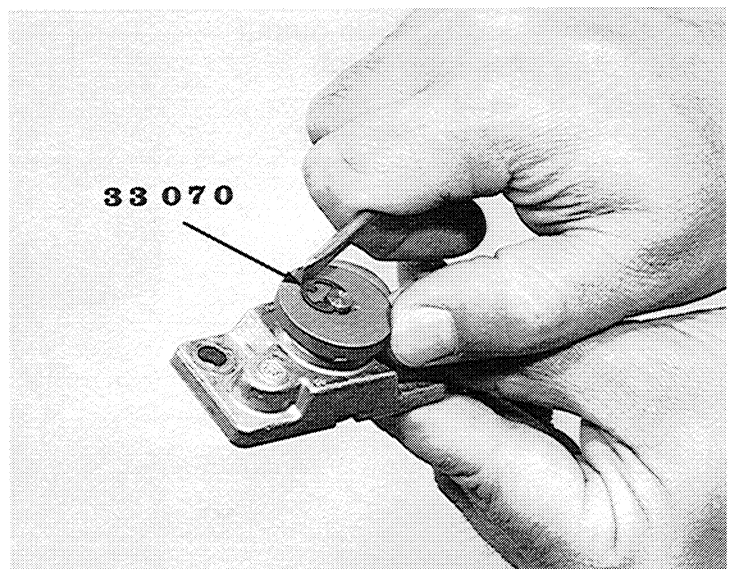

Insert counter weight 33038 into governor hub 33040 and secure with clip 33036.

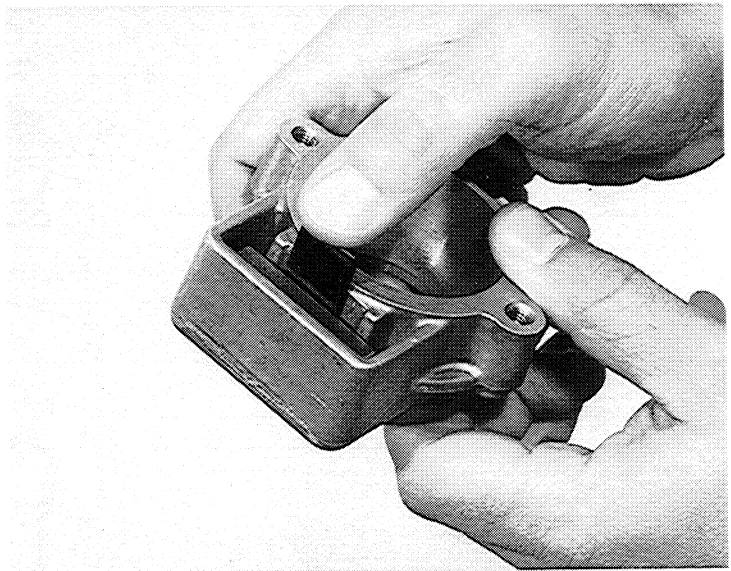

Install parking wheel 24100 with 2 cylindrical bolts 33094 onto governor hub. Install governor housing with 2 cylindrical bolts 33094 onto governor hub (to be torqued 10 Nm) tool size torx bit 27.

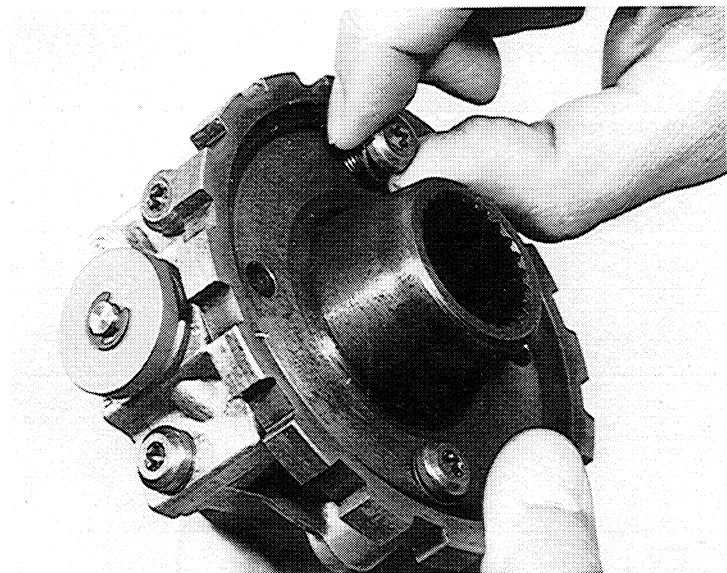

Fit governor assembly onto output shaft and push to stop point.  
**Attention:** to avoid damage to o-ring use vaseline. Seal rings on cylinder F must be snapped together.

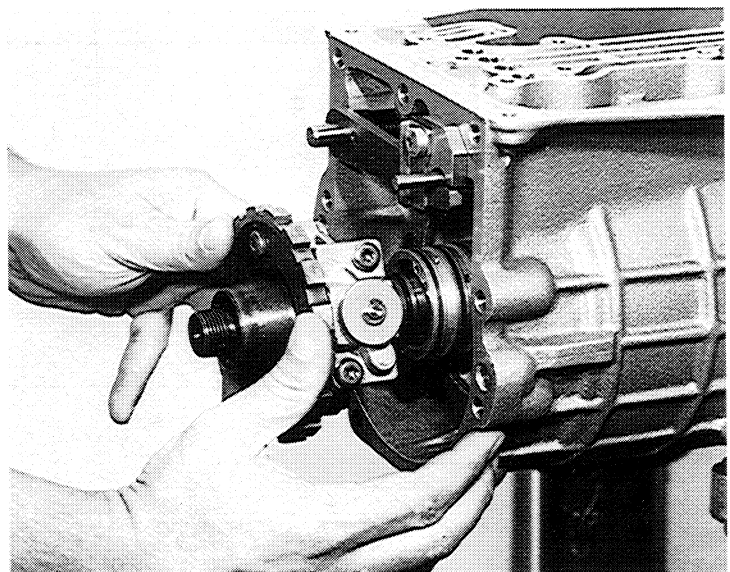

Install needle bearing 25072 with mounting sleeve (5 X 46 000 175) into seat of extension 25010.

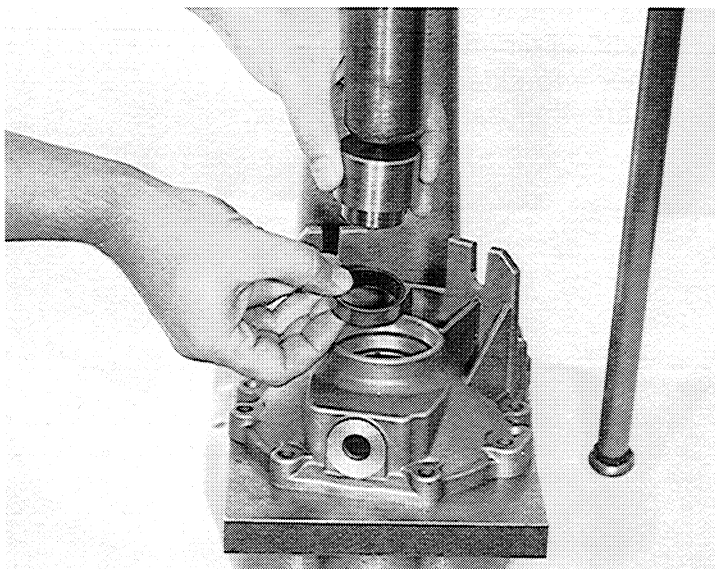

82 031

Press seal ring 25080 with mounting sleeve (5 X 46 000 069) into extension as shown.

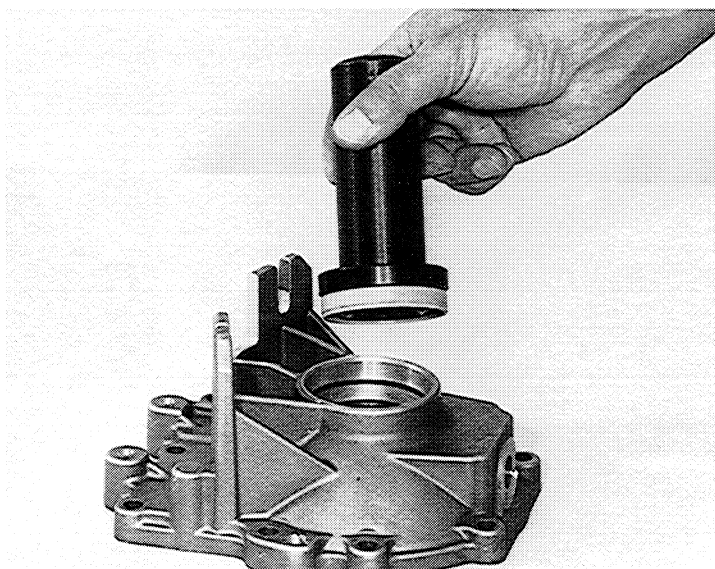

82 168

Insert o-ring 25032 onto breather 25030 and install breather into extension as shown.

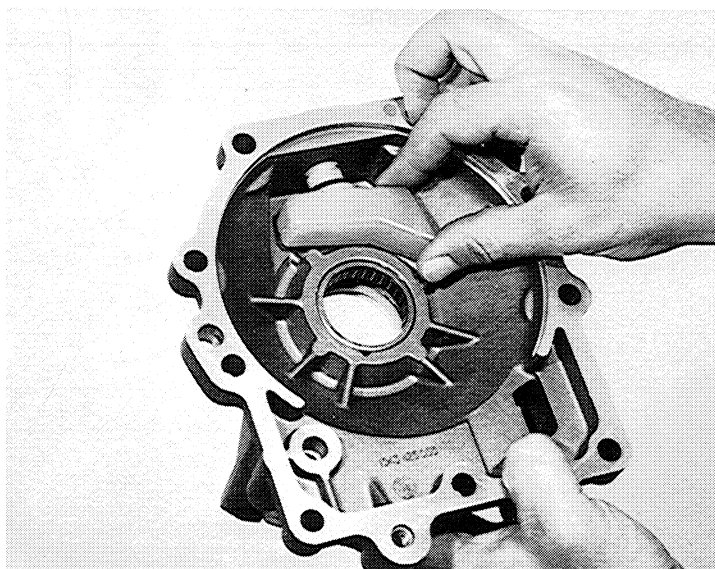

Always use new security clip 025034 when installing breather into extension.  
Snap breather cap onto breather.

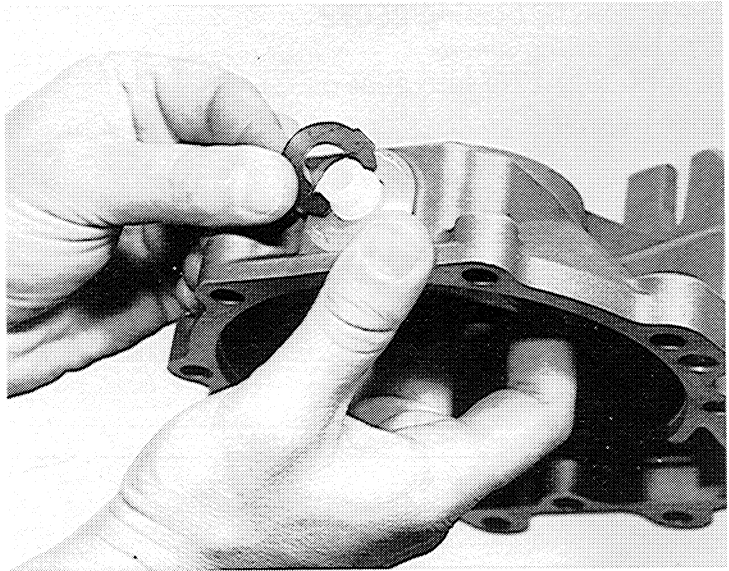

Insert alignment pins into extension as shown.

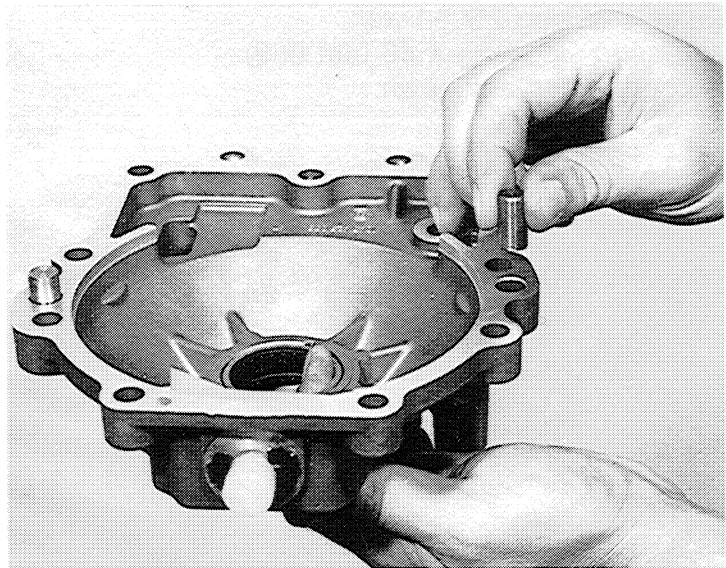

Insert gasket with vaseline onto extension.

Fit extension onto transmission case. If it is necessary use plastic hammer to tap extension into place.

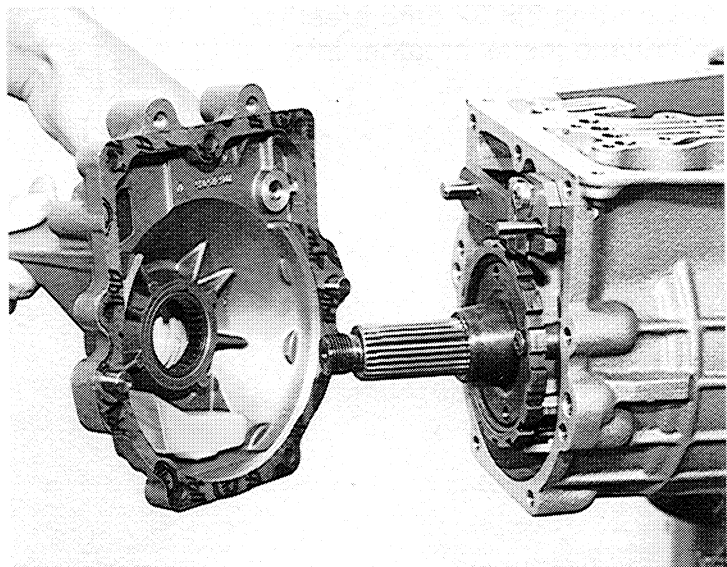



To secure extension onto transmission case, use 9 hexagon bolts 25050.  
(To be torqued - 23 Nm)

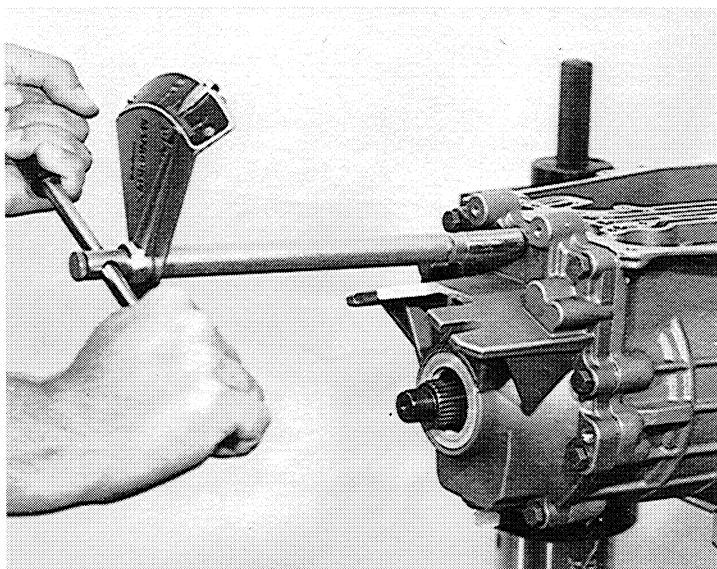

Insert output flange 14060 on output shaft.  
Push in to stop point.

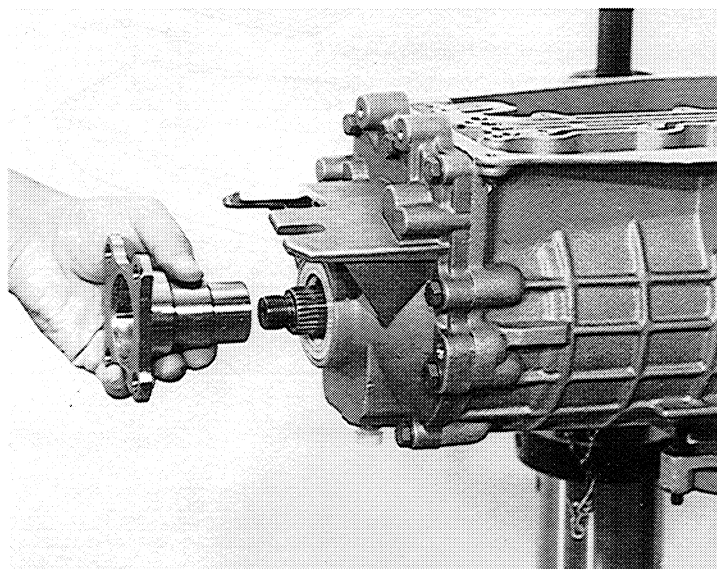

Screw on collar nut 14080 and secure with locking plate 14090.

(To be torqued 100 Nm)  
(Tool size 32 mm)

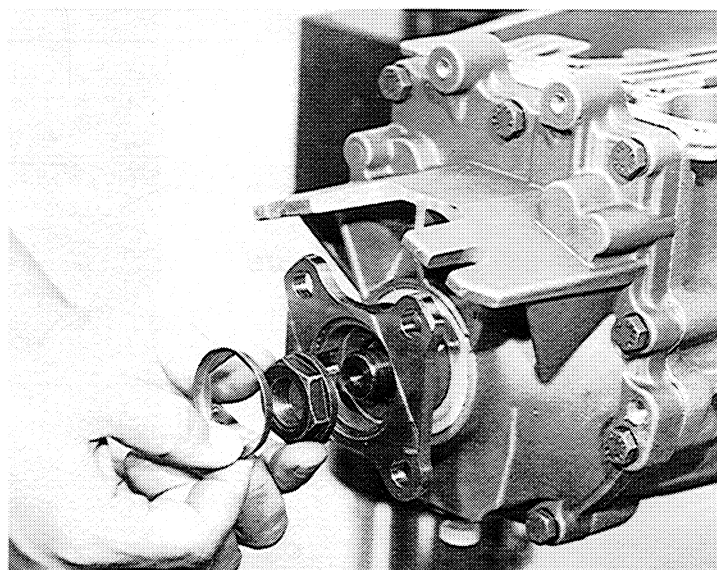

### 3.15 Valve Body, Oil Pan and Torque Converter

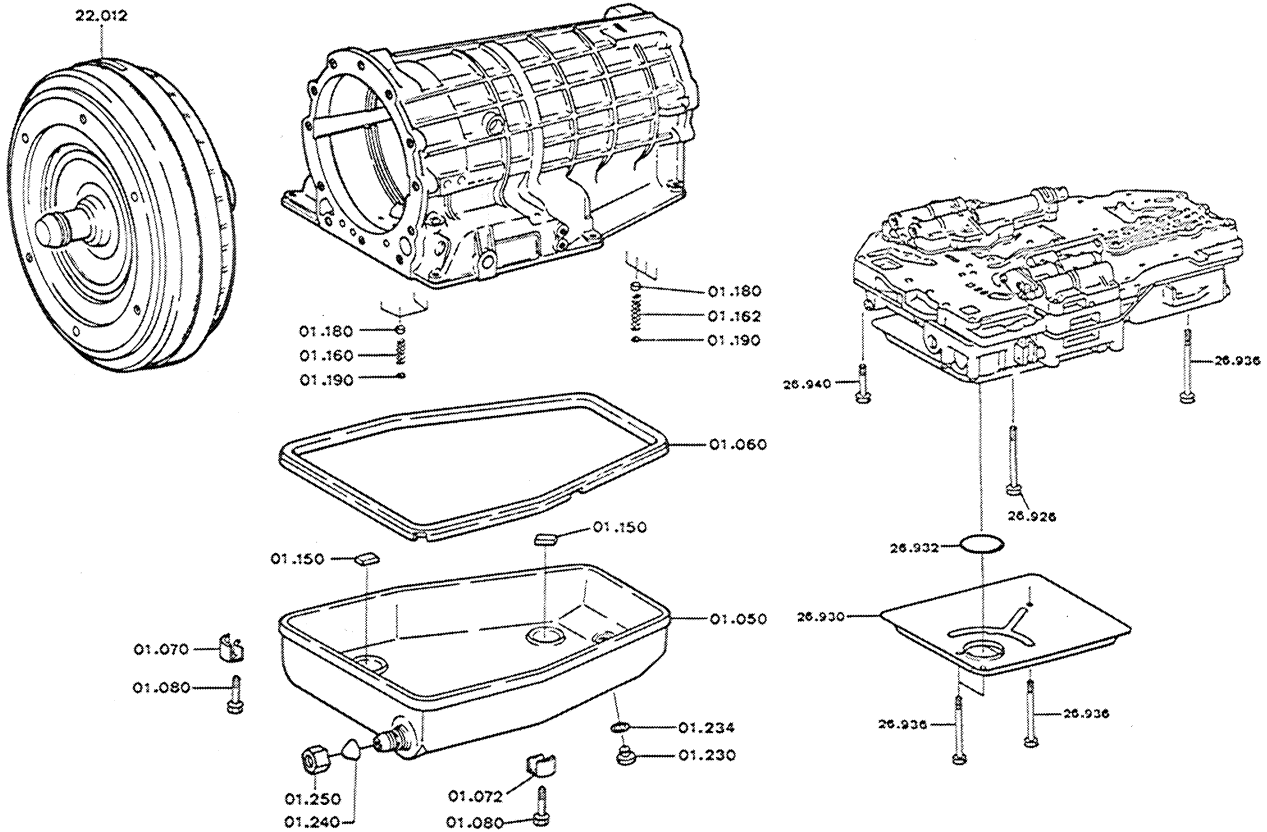

82 174

Insert 8 sealing bushings 01180 into oil feed holes, using suitable punch with plastic hammer to tap bushings into place. To check function of clutch and brake assemblies, insert air gun into oil feed holes (recommended air pressure 5-6 bar).

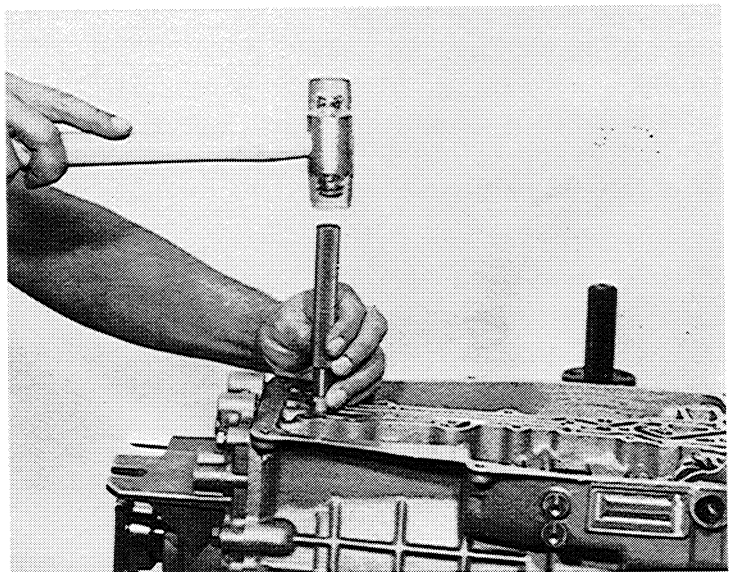

Four short springs 01160 are to be inserted into oil feed holes located in the forward area of transmission case.

Also insert four long springs 01162 into oil feed holes located in the rear area, and secure all springs with circlips 01190.

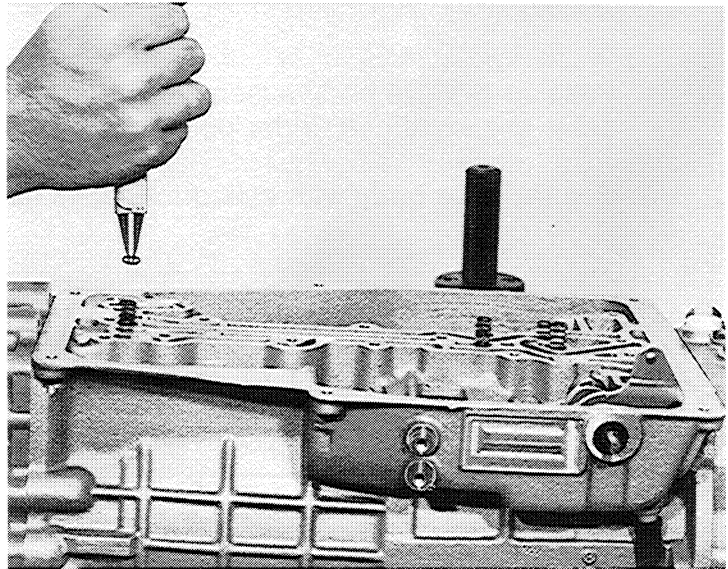

Install valve body assembly on transmission case, and connect pin on stop washer, with valvespool. Pull kick-down cable to position cam for valve body installation.

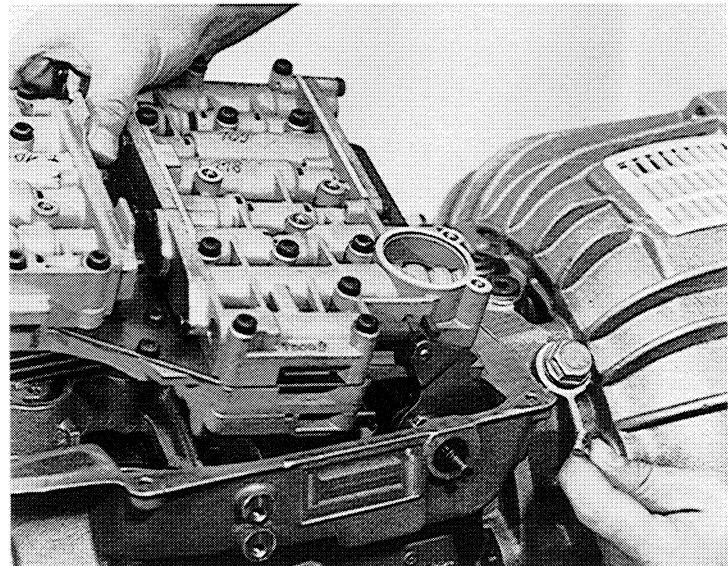

**Attention!**

Position of valve body assembly and adjustment of kick-down cable are explained under point 1.4.1., page 5/1.

Secure valve body with cylindrical bolts as follows:

Position	Quantity	Length (mm)
26/926	3	60
26/936	5	65
26/940	8	30

82 194

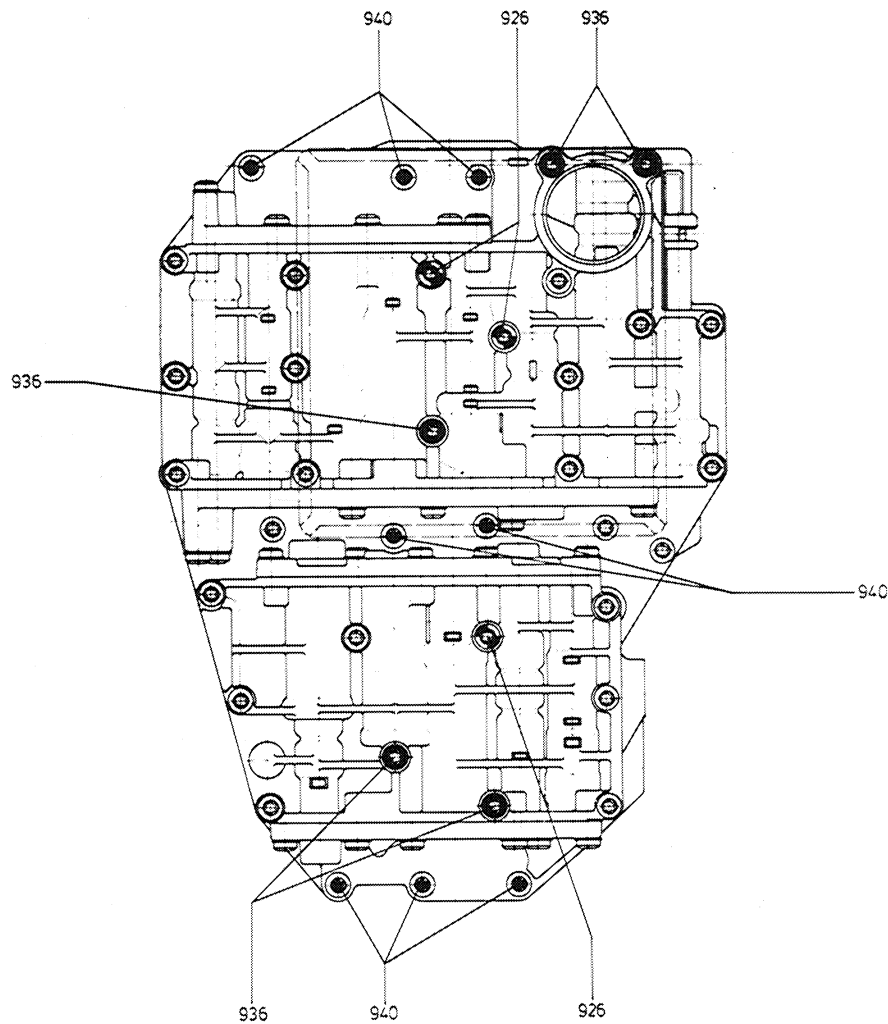

Secure oil screen with 3 bolts in position 26936.

Insert o-ring 26932 onto suction inlet on oil screen 26930. Secure oil screen with 3 cylindrical bolts 26936.

(To be torqued 8 Nm)  
(Tool size torx bit 27)

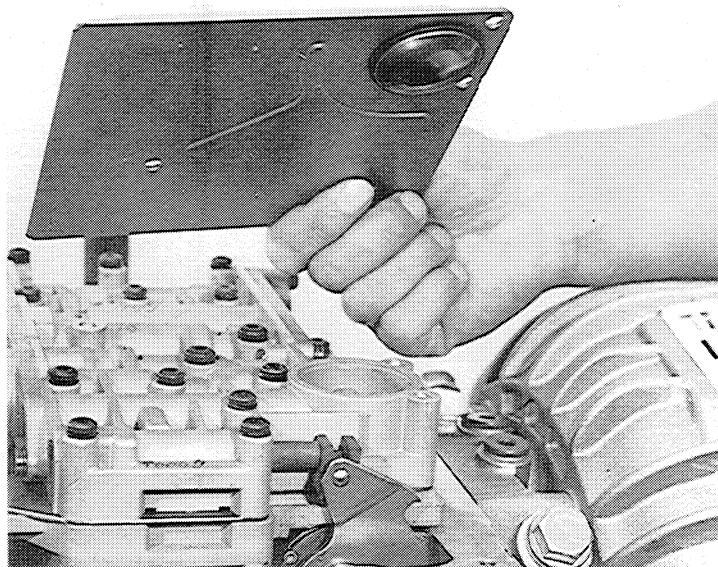

Place 1 magnet 01150 each into 2 indentations in oil pan as shown.

Place gasket onto oil pan. If it is necessary install sealing plugs and sealing washers part numbers:

01230 Plug  
01234 Washer  
01240 Plug  
01250 Nut

Torque information refer to page 6.

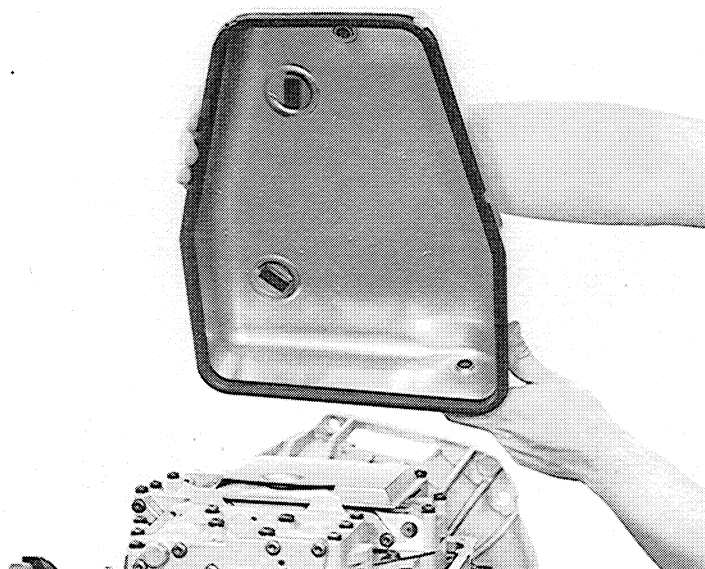

Secure oil pan on four corners with fixation plates 01070. Next secure both sides of oil pan with fixation plates 01072.

Use 6 hexagon bolts, part number 01080, with each of the fixation plates.  
(To be torqued 8 Nm)  
(Tool head size 10 mm)





**Attention:**

With transmission in horizontal position install torque convertor as shown.

To aid installation of torque convertor use mounting grip (5 X 56 000 090).

Torque convertor shaft must be fitted into pump gear drive.

