

Automatic Transmission/Transaxle - TDV6 2.7L Diesel -

Item	Specification
* Recommended lubricant	Shell M13754
+ Torque converter nose	Molybdenum disulphide grease to specification FB180

• **CAUTIONS:**



* Do not use any lubricant other than that specified.



+ Do not over lubricate.

Capacity

Item	Capacity
+ Initial dry fill	9.5 litres (16.7 pints) (10.0 US qts)



CAUTION: + A final oil level check/drain down/top-up must be carried out when the unit has been installed.

General Specification

Item	Specification
Automatic transmission	ZF 6HP26
Speeds	6 Forward, 1 Reverse
Gear ratios:	
First	4.17:1
Second	2.340:1
Third	1.521:1
Fourth	1.143:1
Fifth	0.867:1
Sixth	0.691:1
Reverse	3.403:1
Torque converter	Sachs W255 2GWK with turbine torsional damper and slip controlled, dual friction faced lock-up clutch
Transmission control module:	
Location	Located in gearbox casing
Type	1904

Torque Specifications

Description	Nm	lb-ft
Main control valve body Torx screws	8	6
Transmission heat shield bolts	10	7
Transmission heat shield bracket bolts	10	7
Selector cable bracket nut	12	9
Selector cable bracket bolts	10	7
Wiring harness bracket Torx bolt	10	7
Fluid pan Torx screws	8	6
Engine RH support nut	90	66
Transmission support insulator bolts	60	44
Selector shaft nut	12	9
Selector cable bracket bolts	10	7
Flexplate to torque converter bolts	45	33
Transmission bolts	45	33
Transmission breather pipe clip bolt	25	18
Transmission fluid lines clip bolt	10	7
Radiator access panel bolts	10	7
Exhaust cross-over pipe center support bracket bolts	25	18
Exhaust cross-over pipe LH/RH support bracket bolts	25	18
Turbocharger support bracket nut and bolts	22	16
Transmission fluid drain plug	9	6.5
Transmission fluid filler/level plug	35	26
transmission heat shield bolts	10	7
Transmission under shield bolts	10	7
Transfer case retaining bolts	45	33
* Exhaust crossover pipe retaining nuts	22	16
Exhaust manifold heat shield retaining bolts	10	7

*** New nuts must be installed**

Automatic Transmission/Transaxle - TDV6 2.7L Diesel - Automatic Transmission

Description and Operation

For additional information, refer to: [Automatic Transmission](#) (307-01B Automatic Transmission/Transaxle - V6 4.0L Petrol, Description and Operation).

Automatic Transmission/Transaxle - TDV6 2.7L Diesel - Automatic Transmission

Diagnosis and Testing

Principle of Operation

For detailed description of the automatic transmission system and operation, refer to the relevant Description and Operation section of the workshop manual.

REFER to: [Automatic Transmission](#) (307-01A Automatic Transmission/Transaxle - TDV6 2.7L Diesel, Description and Operation).

Inspection and Verification

This section is intended to provide a means for the technician to diagnose transmission component faults, rather than replacing the entire unit.

However, there are a number of situations where the replacement of the unit is the only practical solution, and this section will cover the diagnosis necessary to gather the information required for transmission replacement to be authorized by the warranty prior approval program (WPAP) where it applies, as well as covering the diagnostic trouble codes (DTCs) stored by the control module.

The basic checks of the transmission (fluid condition and level, etc) should be carried out first, and this will mean using the approved diagnostic system or other equipment with data logging facility to monitor temperatures, etc.

For information on the operation of the transmission, refer to the relevant workshop manual section.

1. **1.** Verify the customer concern.
2. **2.** Visually inspect for obvious signs of mechanical or electrical damage.

Visual Inspection

Mechanical	Electrical
<ul style="list-style-type: none"> ● Fluid condition ● Fluid level ● Fluid leaks ● Fluid cooler ● External linkages ● Gear selector lever 	<ul style="list-style-type: none"> ● Fuses ● Wiring harnesses ● Electrical connector(s) ● Transmission control module (TCM) ● Engine control module (ECM)

3. **3.** If an obvious cause for an observed or reported concern is found, correct the cause (if possible) before proceeding to the next step.
4. **4.** Use the approved diagnostic system or a scan tool to retrieve any DTCs before moving onto the DTC index.
 - Because the DTCs are stored in more than one module, a complete vehicle read is recommended
 - Make sure that all DTCs are cleared following rectification.

Preliminary Inspection

1. **1.** As much information as possible should be obtained from the owner/driver about the fault in order to assist with the diagnosis. Time spent on this will reduce the necessity for extensive road testing and possible missed diagnosis.
 - The information required for WPAP is still useful as an aid to diagnosis, even where the system is not in operation

Required information for WPAP (where applicable)

- The nature of the fault (loss of drive, slip, judder, gear shift quality, noise, etc)
 - The frequency with which the fault occurs
 - The conditions under which the fault occurs, including temperature (coolant and ambient), selected gear, road speed, engine speed, and any specific conditions
 - Check and rectify non-transmission related DTCs before continuing with transmission diagnosis
2. **2.** Record the vehicle details, including:
 - Service history
 - The transmission serial number
 - The transmission software level
 3. **3.** Visually inspect the transmission for fluid leaks, damage, etc.
 4. **4.** Check the transmission fluid condition.

• **NOTE:** Fluid condition is a good indicator of the transmission internal condition. If the fluid is burnt and/or contaminated, this would usually mean the internal damage to the transmission is at such a level that unit replacement is the best option. Compare the fluid drained from the transmission with fresh fluid for color and odor.

5. **5.** Check the transmission fluid level. Refer to the relevant workshop manual section.

• **NOTE:** This is crucial to the operation of the transmission, and the procedure must be closely followed to avoid inaccurate diagnosis, with the resultant possible rejection of a warranty claim.

6. **6.** Check the engine idle speed and throttle sensor using the approved diagnostic system or a scan tool.
7. **7.** Check the transmission selector cable adjustment. Refer to the relevant workshop manual section.
8. **8.** Check the transmission range sensor adjustment.

- A comprehensive procedure for transmission range sensor setting is accessible through the approved diagnostic system.

If any faults are found and rectified in the above sequence, clear any DTCs and test the vehicle for normal operation.

If a failure condition is found indicating the need to renew the transmission assembly, the request must go through the warranty prior approval program (where applicable) before work is begun.

DTC Index

For a list of Diagnostic Trouble Codes (DTCs) that could be logged on this vehicle, please refer to Section 100-00. REFER to: [Diagnostic Trouble Code \(DTC\) Index - DTC: Transmission Control Module \(TCM\) - Bosch](#) (100-00 General Information, Description and Operation).

Automatic Transmission/Transaxle - TDV6 2.7L Diesel - Transmission Fluid Drain and Refill

General Procedures

• WARNINGS:



Observe due care when draining transmission fluid as the fluid can be very hot.



Observe due care when working near a hot exhaust system.

All vehicles

- WARNING:** Do not work on or under a vehicle supported only by a jack. Always support the vehicle on safety stands.

Raise and support the vehicle.

- Remove the transmission undershield.
 - Remove the 6 bolts.

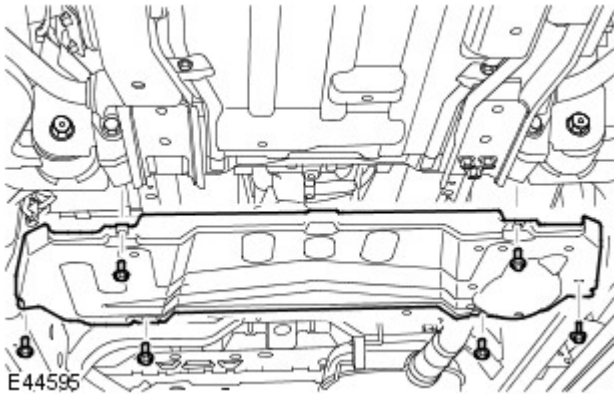

- If installed, remove the transmission heat shield.
 - Remove the 4 bolts.

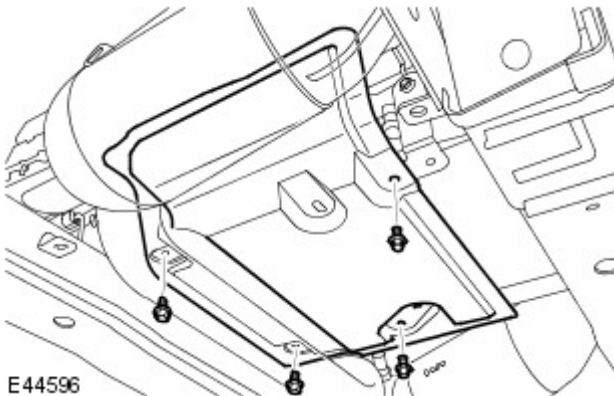

Vehicles with 4.0L engine

- Remove the transmission support insulator through-bolt.
 - Raise the transmission to gain access to the fluid drain plug.

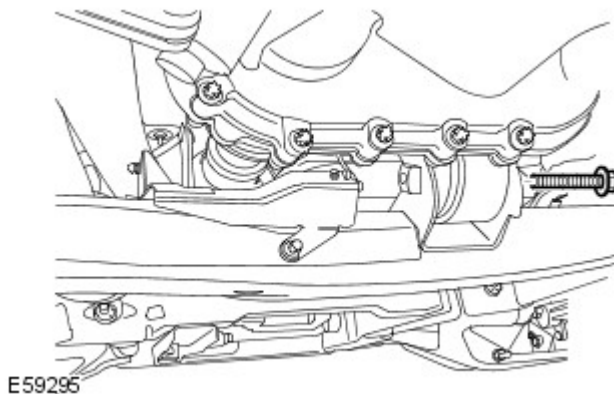

All vehicles

5. Clean the area around the transmission fluid drain and filler plugs.
6. Place a container under the transmission.



7. WARNINGS:



Observe due care when draining transmission fluid as the fluid can be very hot.



Observe due care when working near a hot exhaust system.

Remove the transmission fluid filler/level plug.

- Remove and discard the sealing washer.



8. Remove the transmission fluid drain plug.

- Remove and discard the sealing washer.
- Allow the fluid to drain.

9. Install the transmission fluid drain plug and tighten to 9 Nm (7 lb.ft).

- Install a new sealing washer.

Vehicles with 4.0L engine

10. Install the transmission support insulator through-bolt and tighten to 175 Nm (129 lb.ft).

- Lower the transmission.

All vehicles

11. Add 3.5 to 4 litres of the correct transmission fluid, or until a small thread of fluid runs from the filler/level hole.

12. Check and top-up the transmission fluid level.

For additional information, refer to: [Transmission Fluid Level Check](#) (307-01A Automatic Transmission/Transaxle - TDV6 2.7L Diesel, General Procedures).

Automatic Transmission/Transaxle - TDV6 2.7L Diesel - Transmission Fluid Level Check

General Procedures

• WARNINGS:



Observe due care when draining transmission fluid as the fluid can be very hot.



Observe due care when working near a hot exhaust system.



CAUTION: The gearbox fluid level must only be checked when the temperature of the fluid is between 30 degrees and 50 degrees. The fluid level obtained will be incorrect if the reading is outside this temperature range.

1. The following steps must be observed before starting the transmission fluid level check and top-up.

- The vehicle must be on a horizontal ramp.
- The parking brake must be applied.
- The wheels must be chocked.



2. **CAUTION:** Make sure the transmission fluid temperature is below 30 degrees before starting the fluid level check.

Using the approved Land Rover diagnostic equipment, monitor the transmission fluid temperature.

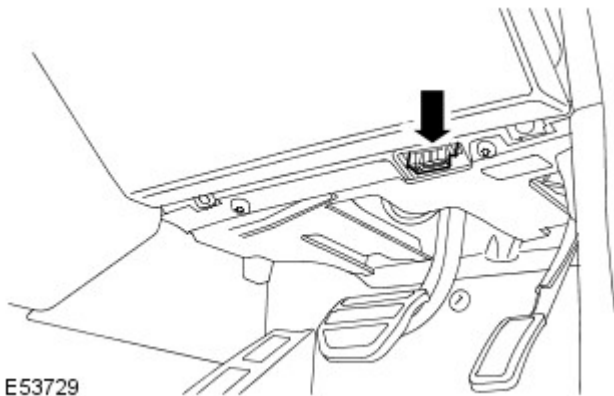

E53729

3. Start the engine. Move the selector lever from 'P' through all gear positions, pausing in each gear position for 2-3 seconds and return to the 'P' position.

4.  **WARNING:** Do not work on or under a vehicle supported only by a jack. Always support the vehicle on safety stands.

Raise and support the vehicle.

5. Remove the transmission undershield.

- Remove the 6 bolts.

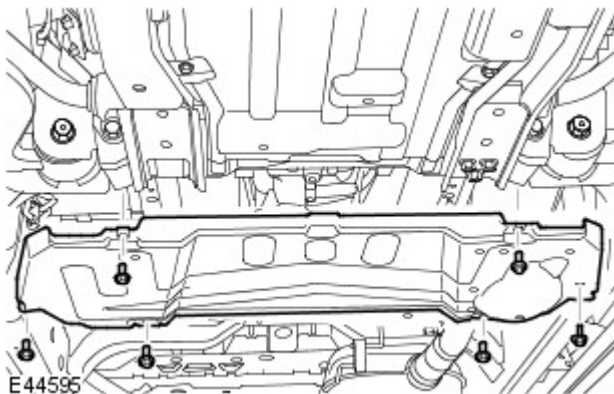

E44595

6. If installed, remove the transmission heat shield.

- Remove the 4 bolts.

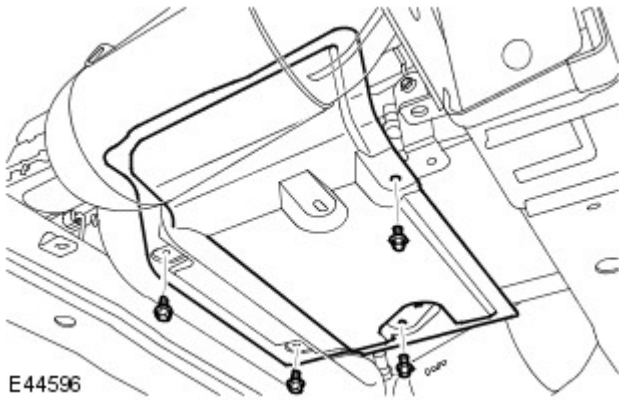

7. Place a container under the transmission.

8. WARNINGS:

 Observe due care when draining transmission fluid as the fluid can be very hot.

 Observe due care when working near a hot exhaust system.

 **CAUTION:** The gearbox fluid level must only be checked when the temperature of the fluid is between 30 degrees and 50 degrees. The fluid level obtained will be incorrect if the reading is outside this temperature range.

Remove the transmission fluid filler/level plug.

- Clean the area around the filler/level plug.
- Remove and discard the sealing washer.

9. If no fluid loss is apparent when the filler/level plug is removed, with the engine at idle, continue to fill the transmission until a small thread of oil runs from oil filler/level hole.

10. Install the transmission fluid filler/level plug and tighten to 35 Nm (26 lb.ft).

- Install a new sealing washer.
- Remove the container.

11. If installed, install the transmission heat shield.

- Tighten the bolts to 10 Nm (7 lb.ft).

12. Install the transmission undershield.



- Tighten the bolts to 10 Nm (7 lb.ft).

13. Disconnect the approved Land Rover diagnostic equipment from the vehicle.



Automatic Transmission/Transaxle - TDV6 2.7L Diesel - Selector Shaft Seal

In-vehicle Repair

Special Tool(s)	
 <p>307-509-1 E50766</p>	<p>ZF Automatic transmission selector shaft seal remover 307-509-1 (LRT-44-033/1)</p>
 <p>307-509-2 E50767</p>	<p>ZF Automatic transmission selector shaft seal remover 307-509-2 (LRT-44-033/2)</p>
 <p>307-509-3 E50768</p>	<p>ZF Automatic transmission selector shaft seal installer 307-509-3 (LRT-44-033/3)</p>

Removal

-  **WARNING:** Do not work on or under a vehicle supported only by a jack. Always support the vehicle on safety stands.

Raise and support the vehicle.

- LH selector shaft seal only: Remove the exhaust system. For additional information, refer to: [Exhaust System - Vehicles Without: Diesel Particulate Filter \(DPF\)](#) (309-00A Exhaust System - TDV6 2.7L Diesel, Removal and Installation) / [Exhaust System - Vehicles With: Diesel Particulate Filter \(DPF\)](#) (309-00A Exhaust System - TDV6 2.7L Diesel, Removal and Installation).
- Remove the transmission heat shield.
 - Remove the 4 bolts.

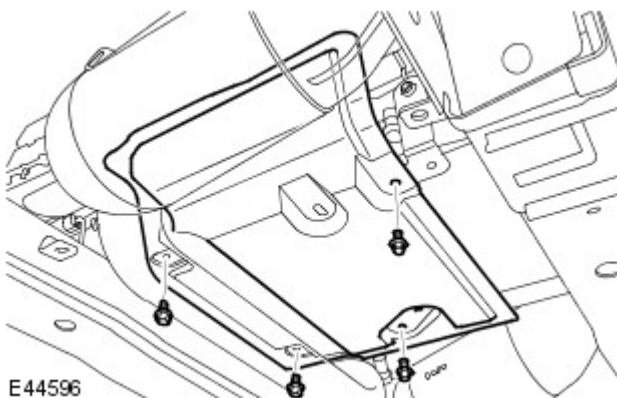

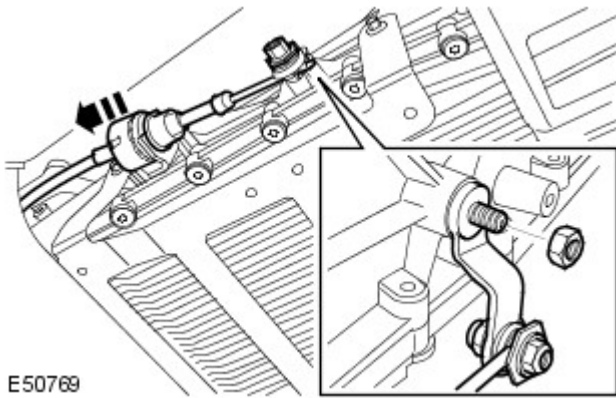



E50769

4. Release the selector cable and lever.

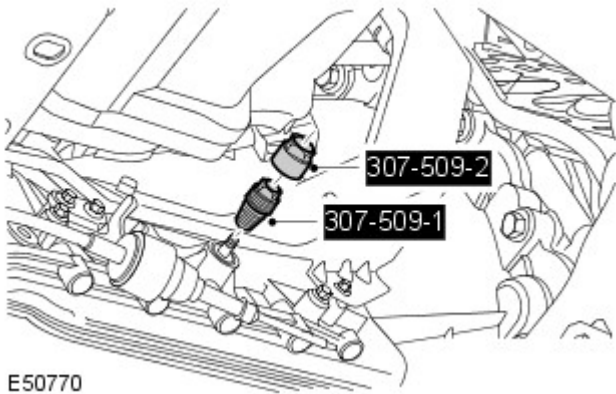
- Remove the nut.
- Compress the latch and release the cable.



E50770

5.  **CAUTION:** Before the disconnection or removal of any components, make sure the area around joint faces and connections are clean. Plug any open connections to prevent contamination.

Remove the selector shaft seal.

- Install 307-509-1 to the seal.
- Install 307-509-2 to 307-509-1 and extract the seal.

Installation

1. **NOTE:** Clean the components.

Using 307-509-3, install the selector shaft seal.

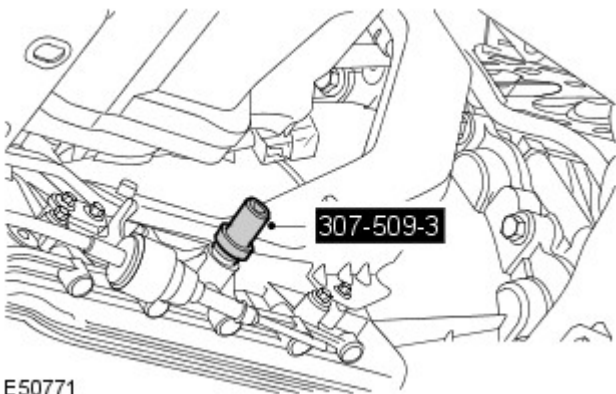

E50771

2. Install the selector cable and bracket.

- Secure with the clip.
- Tighten the nut to 12 Nm (9 lb.ft).

3. Install the transmission heat shield.

- Install the bolts.

4. LH selector shaft seal only: Install the exhaust system. For additional information, refer to: [Exhaust System - Vehicles Without: Diesel Particulate Filter \(DPF\)](#) (309-00A Exhaust System - TDV6 2.7L Diesel, Removal and Installation) / [Exhaust System - Vehicles With: Diesel Particulate Filter \(DPF\)](#) (309-00A Exhaust System - TDV6 2.7L Diesel, Removal and Installation).

Automatic Transmission/Transaxle - TDV6 2.7L Diesel - Transmission Control Module (TCM)

In-vehicle Repair

Special Tool(s)	
	Seal extractor
	307-492 (LRT-44-005)

Removal

- NOTE: The transmission control module (TCM) is part of the main control valve body and cannot be serviced separately.

-  **WARNING:** Do not work on or under a vehicle supported only by a jack. Always support the vehicle on safety stands.

Raise and support the vehicle.

- Remove the fluid pan.
For additional information, refer to: [Fluid Pan, Gasket and Filter](#) (307-01A Automatic Transmission/Transaxle - TDV6 2.7L Diesel, In-vehicle Repair).
- Disconnect the electrical connector.

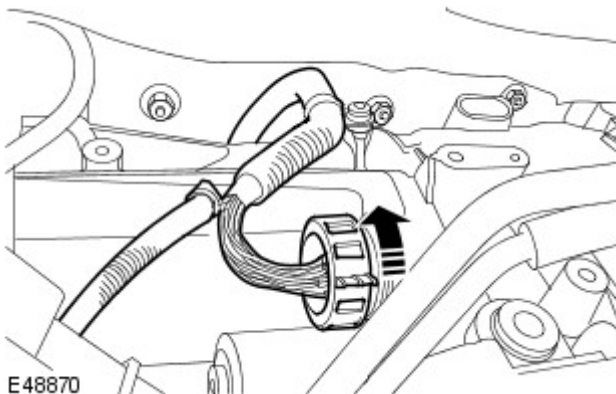

E48870

- Remove and discard the electrical connector sleeve.

- Release the retainer.

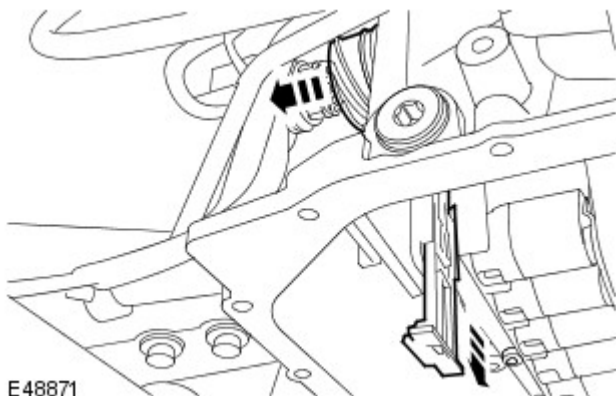

E48871

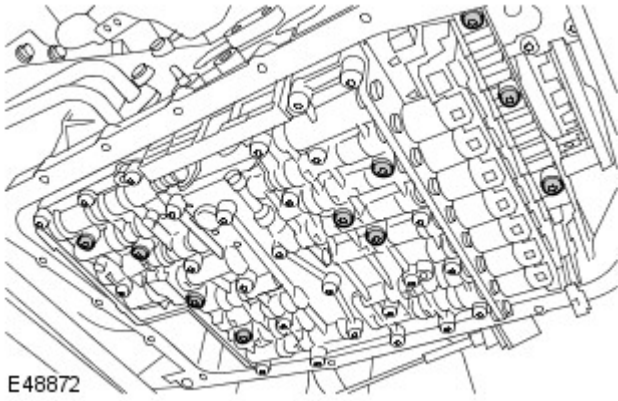

5. Remove the valve body.

- Position a container to collect spillage.
- Remove the 10 Torx screws.

- 6. Using the special tool, remove the 4 seals.**
7. Remove the seal block.

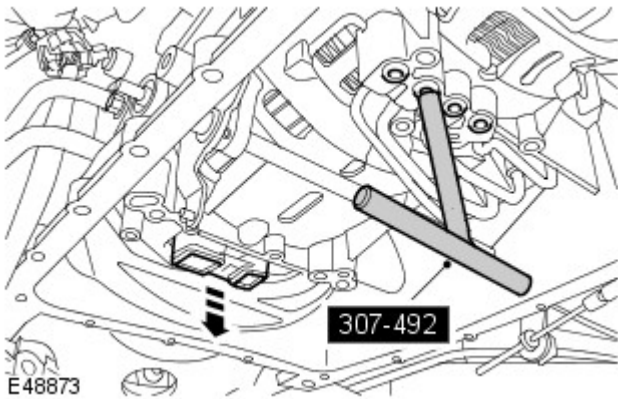

Installation

1. CAUTIONS:

- ⚠ Make sure that when fully fitted, all seals protrude by the same amount.
- ⚠ Engage the selector lever with the groove in the piston rod.

Install the valve body.

- Clean the component mating faces.
- Install new seals.
- Install a new seal block.
- Tighten the Torx screws to 8 Nm (6 lb.ft).

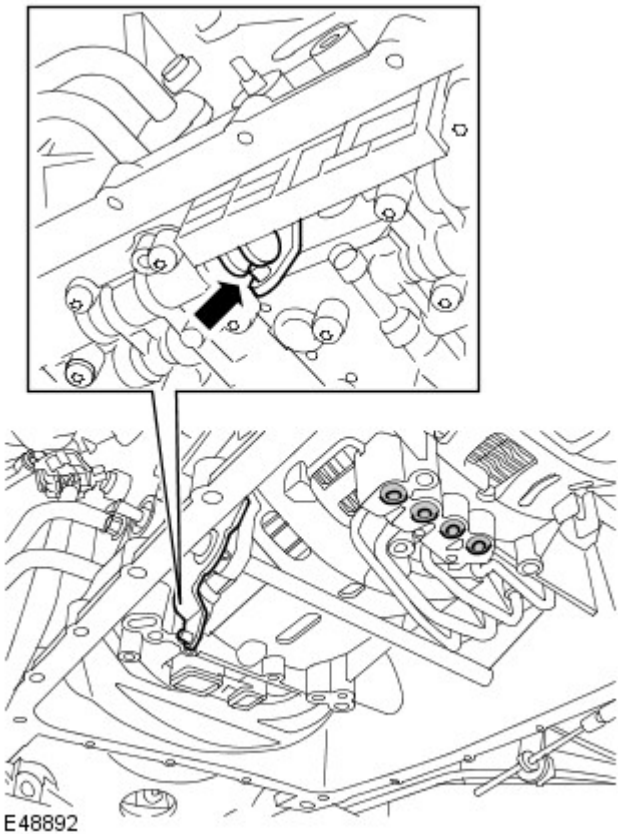

- 2. Install a new electrical connector sleeve.**

- Secure with retainer.

3. Connect the electrical connector.



4. Install the fluid pan.

For additional information, refer to: [Fluid Pan, Gasket and Filter](#) (307-01A Automatic Transmission/Transaxle - TDV6 2.7L Diesel, In-vehicle Repair).

5. Using T4, calibrate a new TCM.

Automatic Transmission/Transaxle - TDV6 2.7L Diesel - Output Shaft Seal

In-vehicle Repair

Special Tool(s)	
 <p>303-903 E50940</p>	<p>Oil seal remover 303-903 (LRT-12-092)</p>
 <p>307-520 E52536</p>	<p>Oil seal installer 307-520</p>

Removal

-  **WARNING:** Do not work on or under a vehicle supported only by a jack. Always support the vehicle on safety stands.

Raise and support the vehicle.

- Remove the transfer case.
For additional information, refer to: [Transfer Case - TDV6 3.0L Diesel](#) (308-07B Transfer Case, Removal).

-  **CAUTION:** Care must be taken to avoid damage to the seal register and running surface.

Remove the transmission output shaft oil seal.

- Use the special tool.

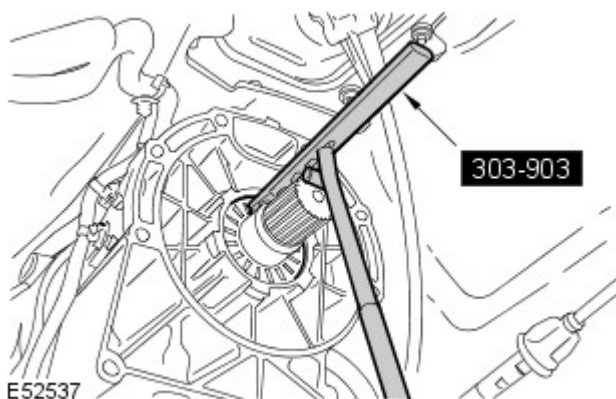

Installation

-  **CAUTION:** Oil seals must be fitted dry.

Install a new transmission output shaft oil seal.

- Clean the seal register.
- Use the special tool.

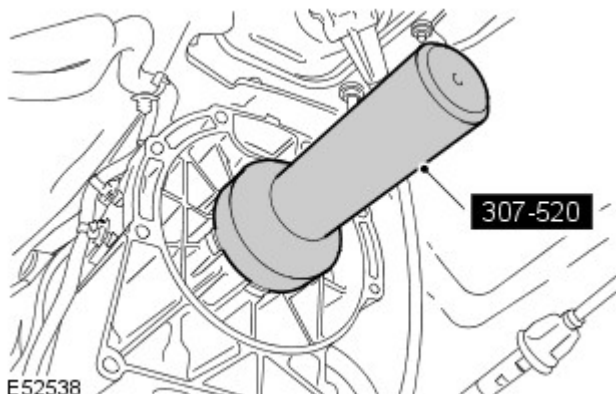

- Install the transfer case.
For additional information, refer to: [Transfer Case - TDV6 3.0L](#)

[Diesel](#) (308-07B Transfer Case, Removal).

- 3.** Check and top-up the transmission fluid level.
For additional information, refer to: [Transmission Fluid Level Check](#) (307-01A Automatic Transmission/Transaxle - TDV6 2.7L Diesel, General Procedures).

Automatic Transmission/Transaxle - TDV6 2.7L Diesel - Fluid Pan, Gasket and Filter

In-vehicle Repair

Removal

1. Disconnect the battery ground cable.
For additional information, refer to: [Specifications](#) (414-00 Battery and Charging System - General Information, Specifications).

2.  **WARNING:** Do not work on or under a vehicle supported only by a jack. Always support the vehicle on safety stands.

Raise and support the vehicle.

3. Remove the transmission heat shield.
 - Remove the four retaining bolts.

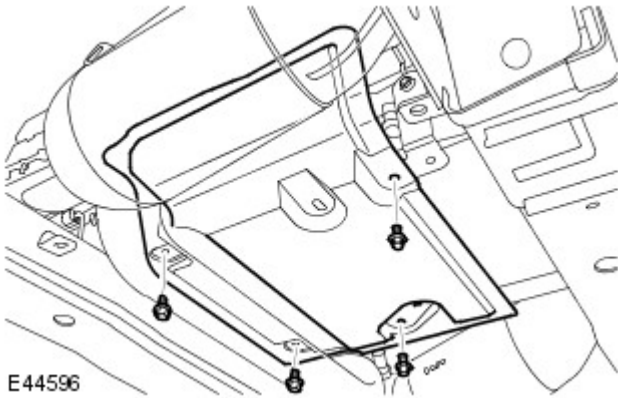

4. Release the selector cable from its abutment bracket.

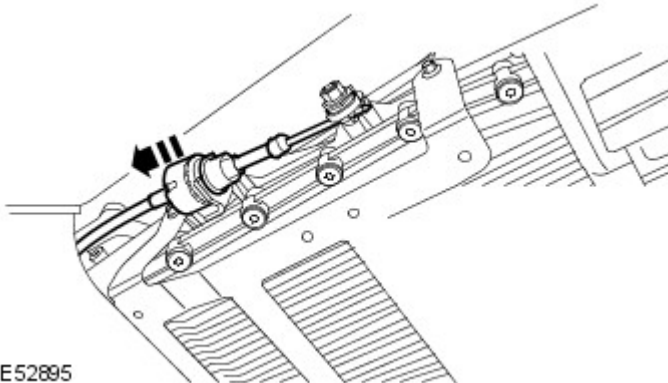

5. Remove the transmission heat shield bracket.
 - Remove the four retaining bolts.

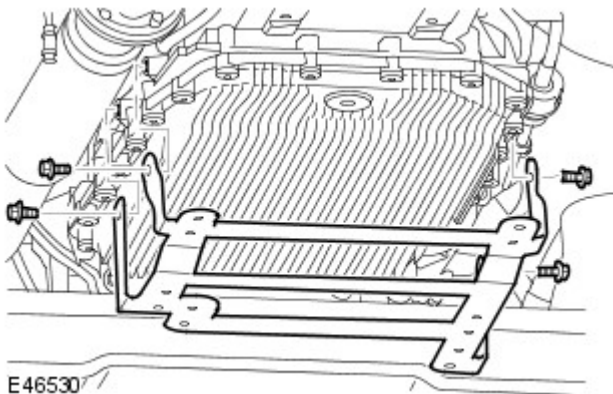

6. Drain the transmission fluid.
For additional information, refer to: [Transmission Fluid Drain and Refill](#) (307-01A Automatic Transmission/Transaxle - TDV6 2.7L Diesel, General Procedures).

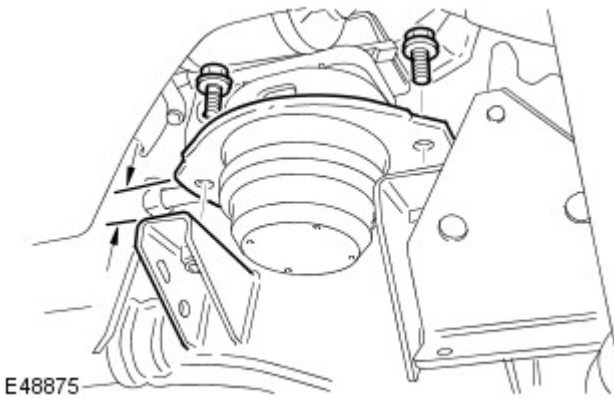

7. ⚠ CAUTION: Protect the engine during this operation.

Raise the RH side of the engine by approximately 35 mm (1.38 in).

- Use a transmission jack.
- Remove and discard the two retaining bolts.

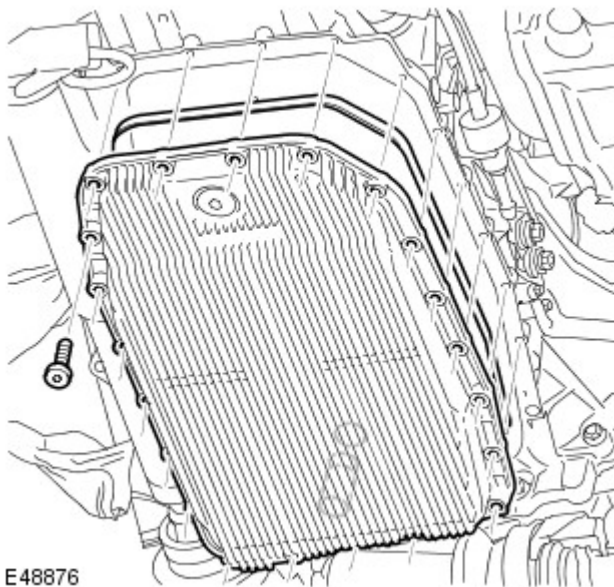

8. Remove the fluid pan, gasket and filter.

- Position a container to collect the fluid spillage.
- Remove the 21 Torx screws.
- Remove and if necessary, discard the seal.
- Discard the O-ring seal.

Installation

- 1. Install the fluid pan, gasket and filter.**
 - Clean the components mating faces.
 - Install a new O-ring seal.
 - Tighten the Torx screws to 8 Nm (6 lb.ft).
- 2. Lower the RH side of the engine.**
 - Remove the transmission jack.
 - Install new engine mounting retaining bolts and tighten to 45 Nm (33 lb.ft).
- 3. Install the transmission heat shield bracket.**
 - Install the four retaining bolts and tighten to 10 Nm (7 lb.ft).
- 4. Install the selector cable to its abutment bracket.**
- 5. Install the transmission heat shield.**
 - Install the four retaining bolts and tighten to 10 Nm (7 lb.ft).
- 6. Connect the battery ground cable.**
 For additional information, refer to: [Specifications](#) (414-00 Battery and Charging System - General Information, Specifications).
- 7. Refill the transmission with fluid.**
 For additional information, refer to: [Transmission Fluid Drain and Refill](#) (307-01A Automatic Transmission/Transaxle - TDV6

2.7L Diesel, General Procedures).

Automatic Transmission/Transaxle - TDV6 2.7L Diesel - Main Control Valve Body

In-vehicle Repair

Special Tool(s)	
	Seal extractor
	307-492(LRT-44-005)

Removal

- **NOTE:** The transmission control module (TCM) is part of the main control valve body and cannot be serviced separately.

1. Disconnect the battery ground cable.
For additional information, refer to: [Specifications](#) (414-00 Battery and Charging System - General Information, Specifications).

2.  **WARNING:** Make sure to support the vehicle with axle stands.

Raise and support the vehicle.

3. Drain the transmission fluid.
For additional information, refer to: [Transmission Fluid Drain and Refill](#) (307-01A Automatic Transmission/Transaxle - TDV6 2.7L Diesel, General Procedures).

4. Remove the transmission support crossmember.
 - Support the transmission on a jack.
 - Remove the transmission mounting securing bolt.
 - Remove the 4 bolts.
 - Remove the transmission support insulator through-bolt.

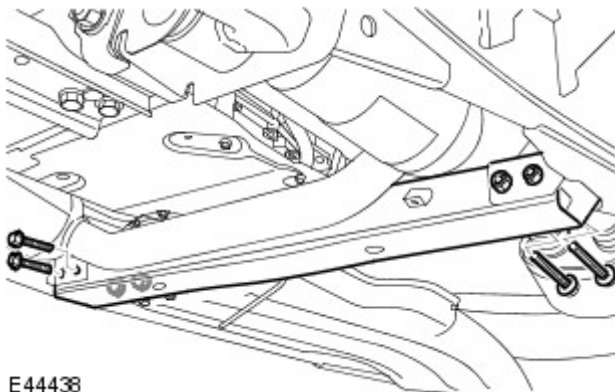

5. Release the fuel filter from its bracket.
 - Tie aside.

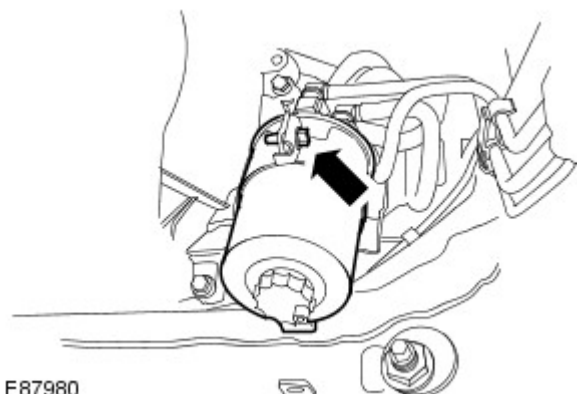

6. Release the support bracket.

- Remove the bolt closest to the engine.
- Release but do not remove the second bolt.

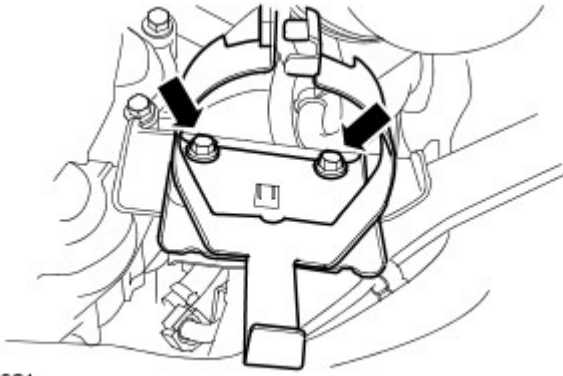

E87981

7. Release the oil pan.

- Position a container to collect the oil spillage.
- Remove the 21 Torx screws.

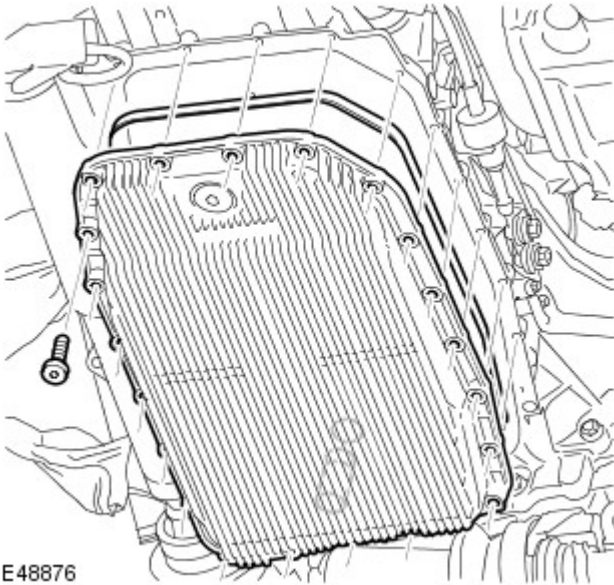

E48876

8. Release and disconnect the electrical connector.

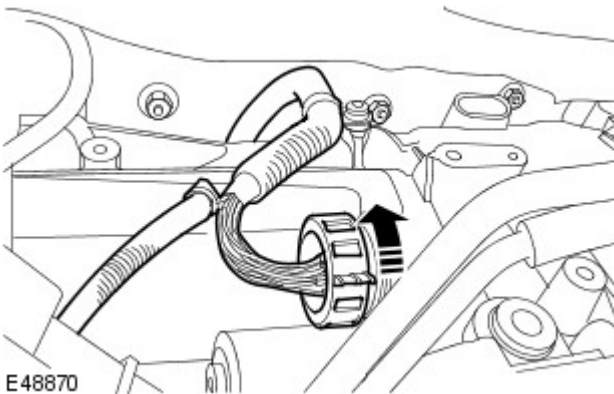

E48870

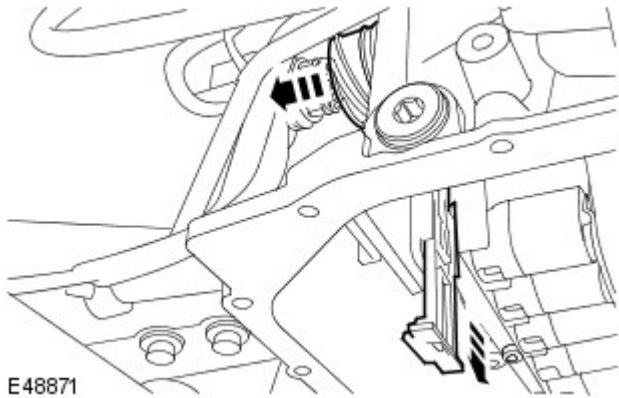

E48871

9. Remove and discard the electrical connector sleeve.

- Release the retainer.

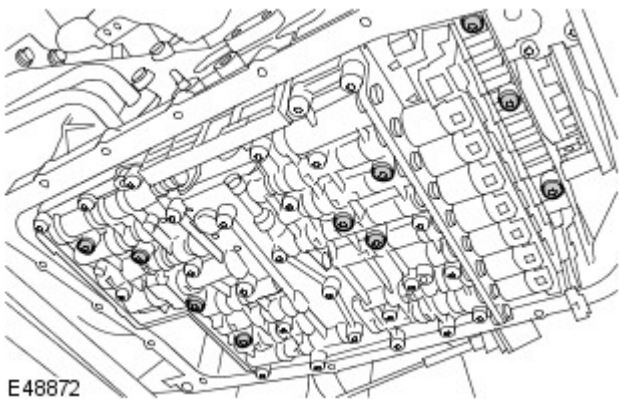

E48872

10. Remove the valve block and oil pan.

- Remove the 7 Torx bolts.
- Discard the O-ring seal.

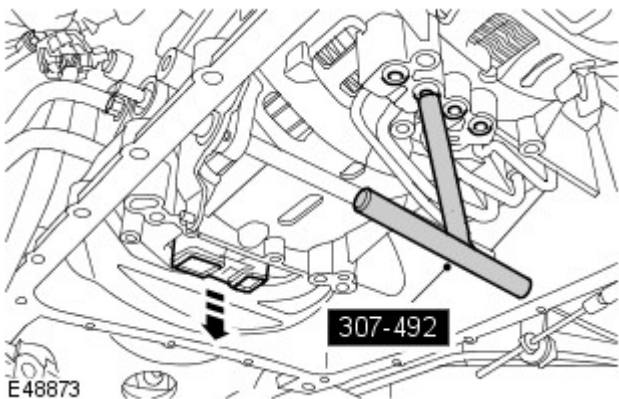

E48873

11. Using the special tool, remove the 4 seals.

12. Remove the seal block.

Installation

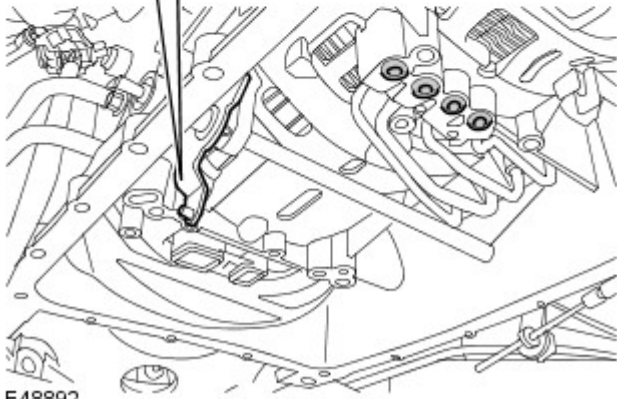
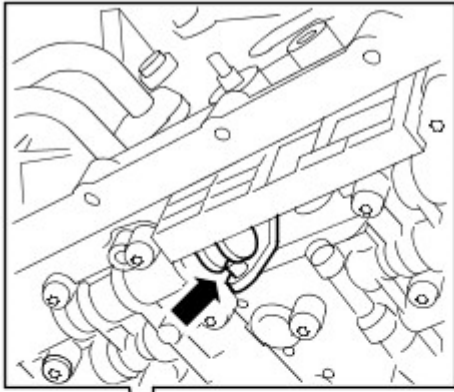

E48892

1. CAUTIONS:



Make sure that when fully fitted, all seals protrude by the same amount.



Engage the selector lever with the groove in the piston rod.

Install the valve block and oil pan.

- Clean the component mating faces.
- Install new seals.
- Install a new seal block.
- Tighten the Torx screws to 8 Nm (6 lb.ft).

2. Install a new electrical connector sleeve.

- Secure with retainer.

3. Connect the electrical connector.

4. Secure the oil pan.

- Tighten the Torx screws to 8 Nm (6 lb.ft).

5. Install the fuel filter support bracket.

6. Install the fuel filter.

7. Install the transmission support crossmember.

- Install the transmission support insulator through-bolt and tighten to 175 Nm (129 lb.ft).
- Install the 4 bolts.
- Tighten the nuts and bolts to 90 Nm (66 lb.ft).
- Remove the transmission jack.

8. Connect the battery ground cable.

For additional information, refer to: [Specifications](#) (414-00 Battery and Charging System - General Information, Specifications).

9. Fill the transmission with fluid.

For additional information, refer to: [Transmission Fluid Drain and Refill](#) (307-01A Automatic Transmission/Transaxle - TDV6 2.7L Diesel, General Procedures).

10. Using the Land Rover approved diagnostic equipment, calibrate the control valve body.

Automatic Transmission/Transaxle - TDV6 2.7L Diesel - Transmission Support Insulator

In-vehicle Repair

Removal

-  **WARNING:** Do not work on or under a vehicle supported only by a jack. Always support the vehicle on safety stands.

Raise and support the vehicle.

- Remove the transmission crossmember.
For additional information, refer to: [Transmission Support Crossmember - V8 5.0L Petrol](#) (502-02 Full Frame and Body Mounting, Removal and Installation).

- NOTE:** 4.4L illustration shown, 4.0L and 2.7L Diesel are similar.

Remove the transmission support insulator.

- Remove the 4 bolts.

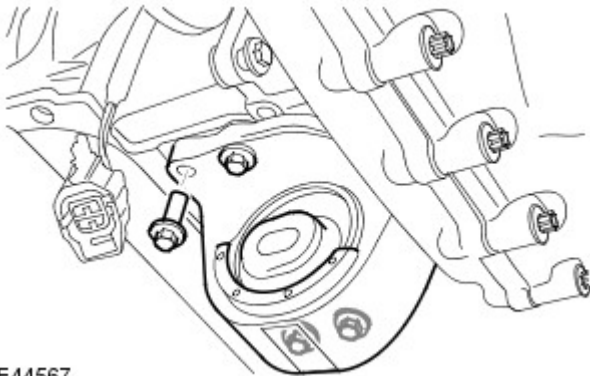

E44567

Installation

- To install, reverse the removal procedure.
 - Clean the component mating faces.
 - Tighten the bolts to 60 Nm (44 lb.ft).

Automatic Transmission/Transaxle - TDV6 2.7L Diesel - Transmission

Removal and Installation

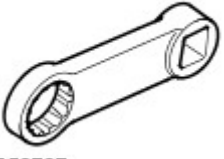
Special Tool(s)	
 <p>303-1069</p> <p>E53727</p>	<p>Wrench adaptor</p> <p>303-1069</p>

Removal

1. Disconnect the battery ground cable.
For additional information, refer to: [Specifications](#) (414-00 Battery and Charging System - General Information, Specifications).
2.  **WARNING:** Do not work on or under a vehicle supported only by a jack. Always support the vehicle on safety stands.

Raise and support the vehicle.
3. Remove the front driveshaft.
For additional information, refer to: [Front Driveshaft - TDV6 2.7L Diesel](#) (205-01 Driveshaft, Removal and Installation).
4. Remove the exhaust system.
For additional information, refer to: [Exhaust System - Vehicles Without: Diesel Particulate Filter \(DPF\)](#) (309-00A Exhaust System - TDV6 2.7L Diesel, Removal and Installation) / [Exhaust System - Vehicles With: Diesel Particulate Filter \(DPF\)](#) (309-00A Exhaust System - TDV6 2.7L Diesel, Removal and Installation).
5. Remove the rear driveshaft.
For additional information, refer to: [Rear Driveshaft](#) (205-01 Driveshaft, Removal and Installation).
6. Remove the starter motor.
For additional information, refer to: [Starter Motor](#) (303-06A Starting System - TDV6 2.7L Diesel, Removal and Installation).
7. Release the selector cable.
 - Using an additional wrench, restrain the clamping bush and loosen the locknut.
 - Compress the latch and release the cable.

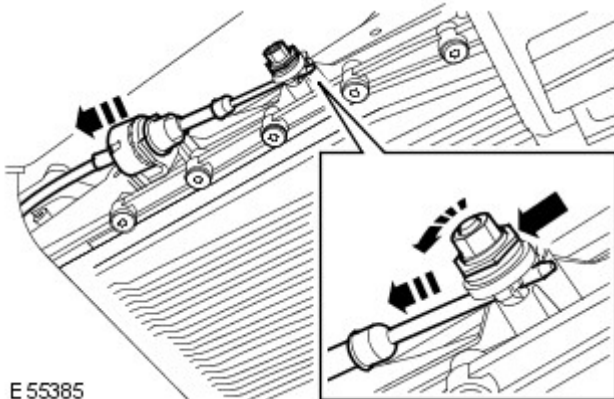

E 55385

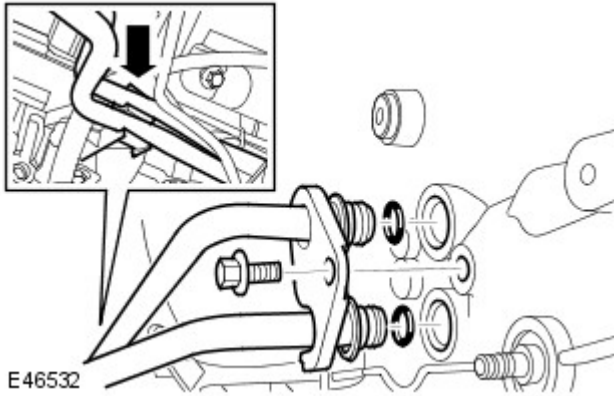

8.  **CAUTION:** Always plug any open connections to prevent contamination.

Disconnect the transmission fluid lines.

- Remove the bolt.
- Release the clip.
- Remove and discard the 2 O-ring seals.

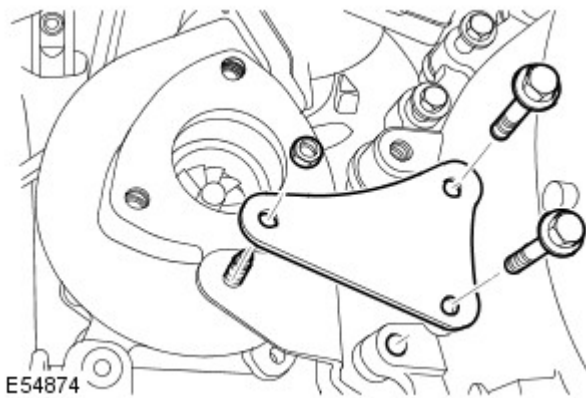

9. Remove the turbocharger support bracket.

- Remove the nut and 2 bolts.

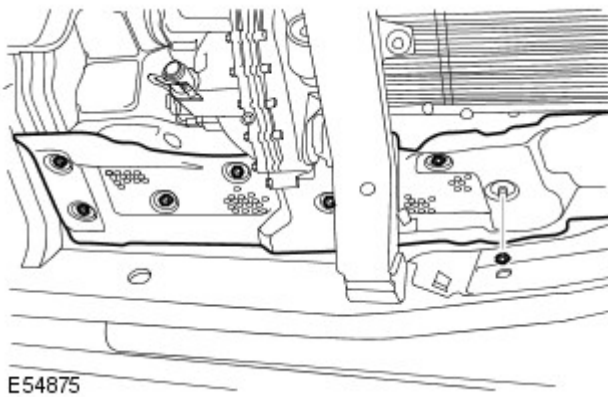

10. Remove the exhaust heat shield.

- Remove the 7 nuts.

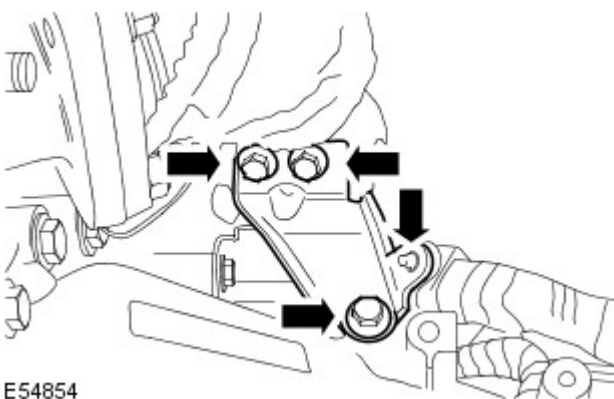

11. Remove the exhaust cross-over pipe LH support bracket.

- Remove the 3 bolts.
- Release the transmission wiring harness.

12. Remove the exhaust cross-over pipe RH support bracket.

- Remove the 3 bolts.

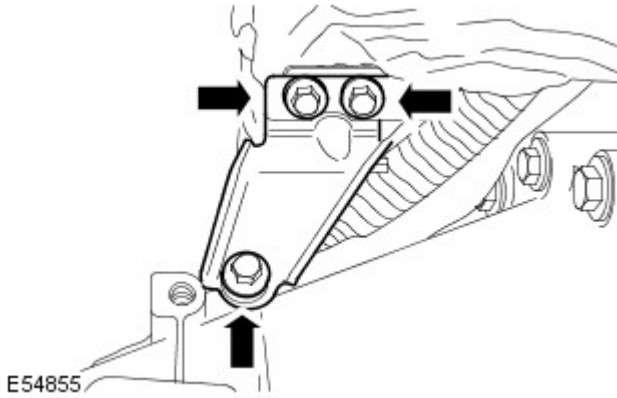

13. Remove the exhaust cross-over pipe center support bracket.

- Remove the 2 bolts.

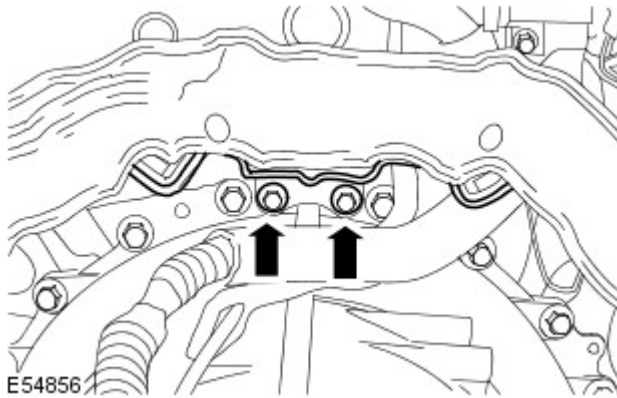

14. Release the wiring harness from the LH side of the transmission.

- Remove the 2 bolts.
- Release the clip.

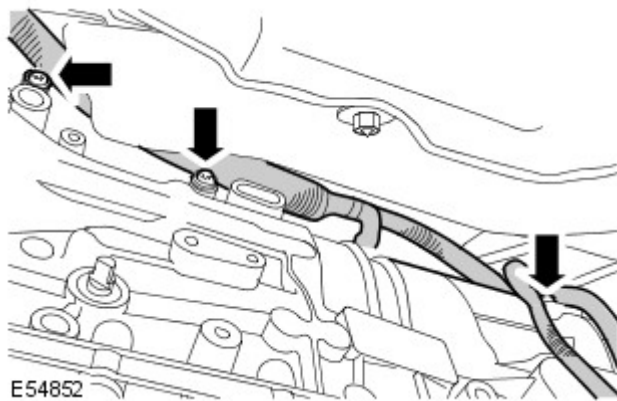

15. Release the wiring harness from the RH side of the transmission.

- Remove the bolt.
- Disconnect the electrical connector.

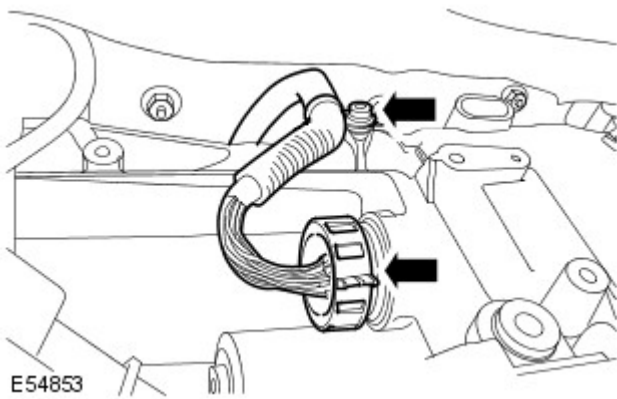

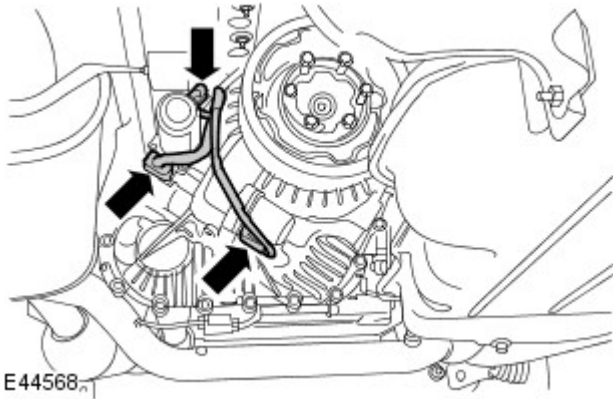

E44568

16. Disconnect the transfer case electrical connectors.

- Disconnect the 3 electrical connectors.

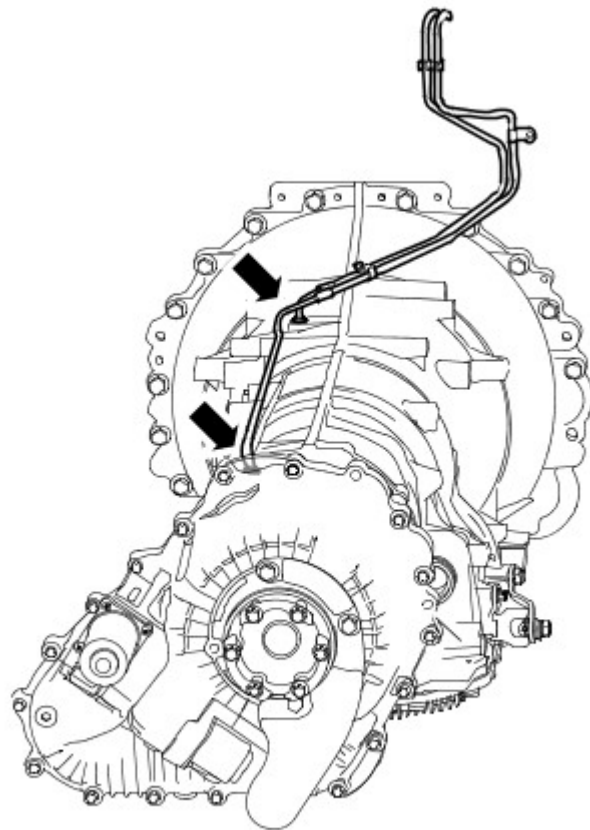

E56515

17.  **CAUTION:** Always plug any open connections to prevent contamination.

- **NOTE:** Transmission shown removed for clarity.

Disconnect the breather line.

- Depress the locking ring.

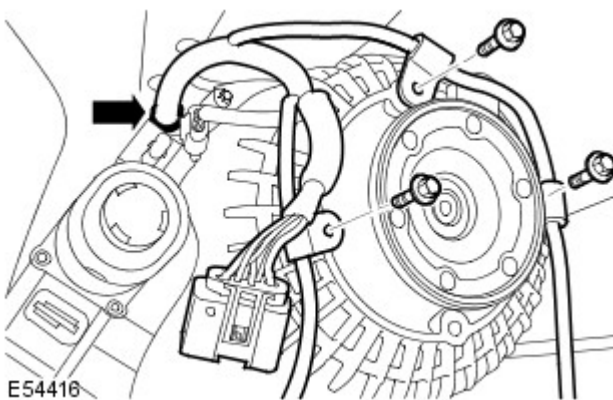

E54416

18. Release the wiring harness from the transfer case.

- Remove the 3 bolts.
- Release the clip.

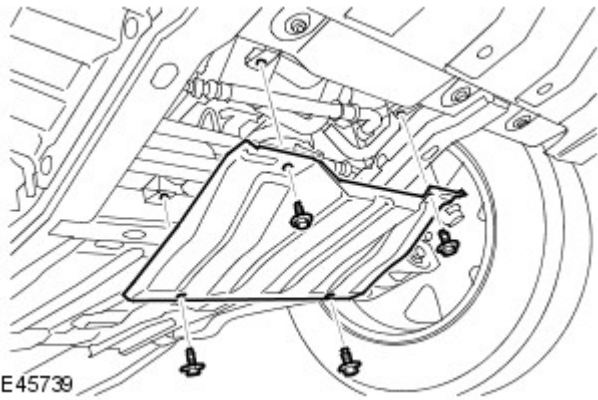

19. Remove the radiator access panel.

- Remove the 4 bolts.

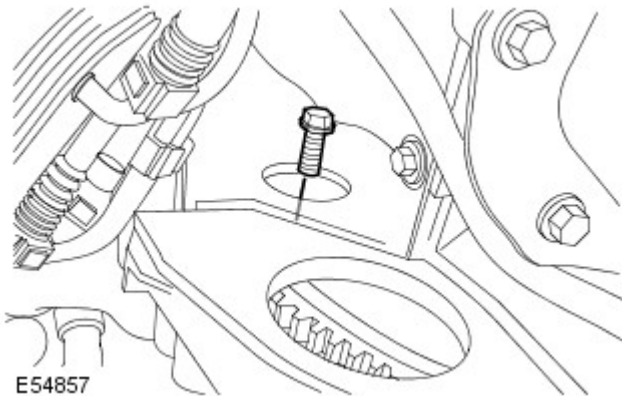

20. Release the flexplate.

- Remove the access plug.
- Rotate the crankshaft in a clockwise direction to access the retaining bolts.
- Remove the 4 bolts.

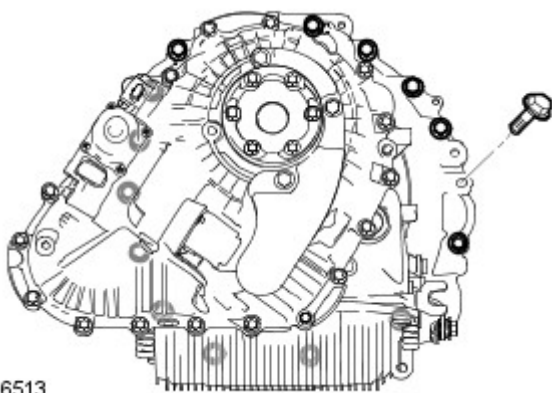

21. Using a transmission jack, support the transmission.

22. WARNINGS:



Secure the transmission to the transmission jack.



Support the engine. The engine will move forward when the transmission is removed.



CAUTION: Make sure the torque converter remains connected to the transmission.

- **NOTE:** Transmission shown removed for clarity.

With assistance, remove the transmission.

- Remove the 15 transmission bolts.

23. Using a suitable tool, retain the torque converter.

24. NOTE: Do not disassemble further if the component is removed for access only.

Remove the transmission from the transmission jack.

25. Drain the transmission fluid.

26. With assistance, remove the transfer case.

- Remove the 8 bolts.
- Remove and discard the O-ring seal.

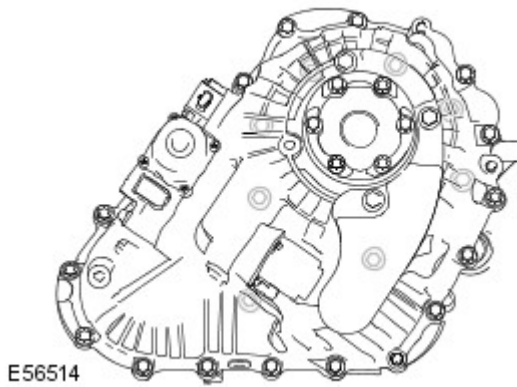

27. Remove the selector cable bracket.

- Remove the bolts.

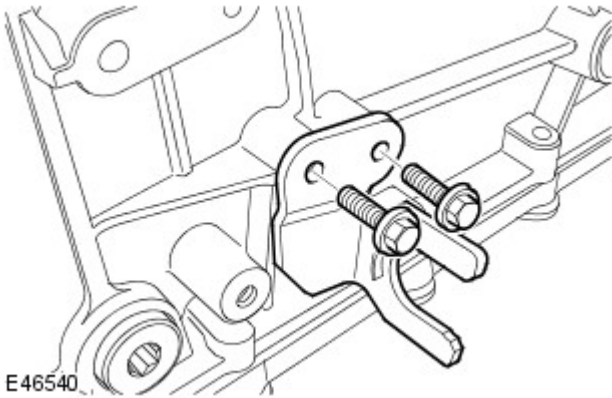

28. Remove the selector lever.

- Remove the nut.

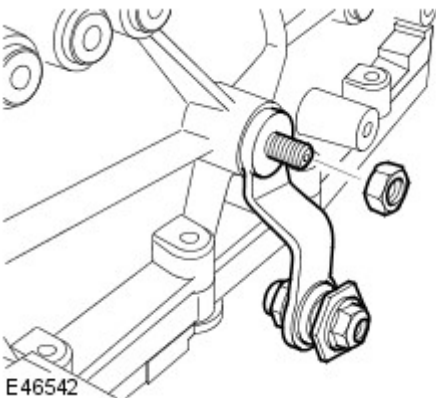

29. Release the fuel filter housing and support bracket.

Installation



CAUTION: If the automatic transmission fluid is very dirty or it contains metallic particles, then along with a new transmission, install a new automatic transmission fluid cooler and lines.

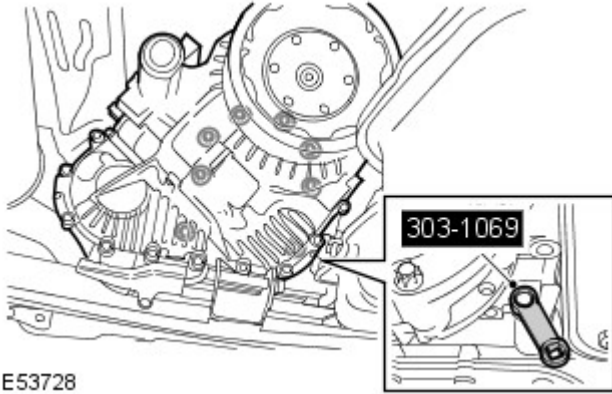

1. NOTE: Clean the component mating faces.

• **NOTE:** Install a new O-ring seal.

With assistance, install the transfer case.

- Lubricate input shaft splines with 'Weicon TL7391' grease.
- Install the 8 bolts.
- Using the special tool, tighten the bolts to 45 Nm (33 lb.ft).

2. Secure the selector lever.

- Tighten the nut to 12 Nm (9 lb.ft).

3. Attach the selector cable bracket.

- Install the 2 bolts and tighten to 10 Nm (7 lb.ft).

4. Secure the wiring harness to the transmission.

- Repeat the above procedure for the other side.
- Tighten the bolt to 10 Nm (7 lb.ft).

5. Using a suitable tool, retain the torque converter.

6. Position the transmission to the transmission jack.

7. Remove the torque converter retainer.

8. NOTE: Apply grease of the correct specification to the torque converter spigot.

• **NOTE:** Clean the component mating faces.

With assistance, install the transmission.

- Tighten the 15 bolts to 45 Nm (33 lb.ft).

9. Connect the breather line.

10. Secure the wiring harness to the transmission.

- Connect the electrical connector.
- Tighten the screws.
- Secure the wiring harness to the transmission.

11. NOTE: Clean the component mating faces.

• **NOTE:** Install the new O-ring seals.

Attach the transmission fluid lines.

- Secure the transmission fluid lines to the clip.
- Tighten the bolt to 10 Nm (7 lb.ft).

12. Attach the flexplate to the torque converter.

- Rotate the crankshaft to access the bolts.
- Install the access plug.
- Tighten the 4 bolts to 45 Nm (33 lb.ft).

13. Install the starter motor.

For additional information, refer to: [Starter Motor](#) (303-06A Starting System - TDV6 2.7L Diesel, Removal and Installation).

14. Install the radiator access panel.

- Install the 4 bolts and tighten to 10 Nm (7 lb.ft).

15. Install the exhaust manifold crossover pipe center support

bracket.

- Loosely install the 2 bolts.

16. Install the exhaust manifold crossover pipe RH support bracket.

- Loosely install the 3 bolts.

17. Install the exhaust manifold crossover pipe LH support bracket.

- Loosely install the 3 bolts.

18. Tighten the exhaust manifold crossover pipe mounting bracket bolts in the following sequence.

- Tighten the 2 bolts marked 1 to 10 Nm (7 lb.ft).
- Loosen the 2 bolts by 90 degrees.
- Tighten the 2 bolts marked 3 to 10 Nm (7lb.ft).
- Loosen the 2 bolts by 90 degrees.
- Tighten the 4 bolts marked 2 to 25 Nm (18 lb. ft).
- Tighten the 2 bolts marked 1 to 25 Nm (18 lb. ft).
- Tighten the 2 bolts marked 3 to 25 Nm (18 lb. ft).
- Attach the wiring harness.

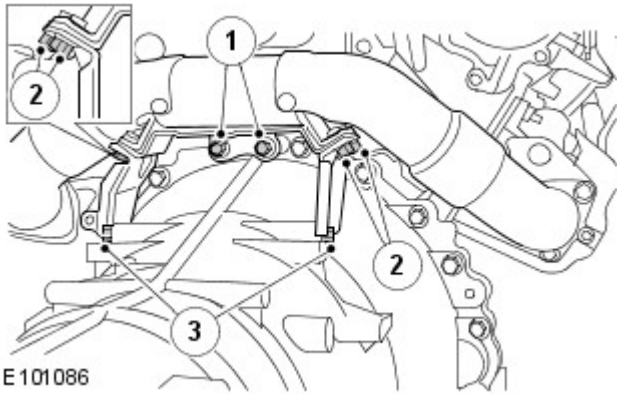

19. Install the exhaust heat shield.

20. Install the turbocharger support bracket.

- Tighten the nut and 2 bolts to 22 Nm (16 lb.ft).

21. Install the rear driveshaft.

For additional information, refer to: [Rear Driveshaft](#) (205-01 Driveshaft, Removal and Installation).

22. Install the front driveshaft.

For additional information, refer to: [Front Driveshaft - TDV6 2.7L Diesel](#) (205-01 Driveshaft, Removal and Installation).

23. Install the exhaust system.

For additional information, refer to: [Exhaust System - Vehicles Without: Diesel Particulate Filter \(DPF\)](#) (309-00A Exhaust System - TDV6 2.7L Diesel, Removal and Installation) / [Exhaust System - Vehicles With: Diesel Particulate Filter \(DPF\)](#) (309-00A Exhaust System - TDV6 2.7L Diesel, Removal and Installation).

24. NOTE: Do not fully tighten the locking nut at this stage.

Connect the selector cable to the transmission.

- Engage the inner cable with the lever clamping bush.
- Install the selector cable to its abutment bracket.

25. Adjust the selector cable.

For additional information, refer to: [Selector Lever Cable Adjustment](#) (307-05B Automatic Transmission/Transaxle External Controls - V6 4.0L Petrol, General Procedures).

26. Connect the battery ground cable.

For additional information, refer to: [Specifications](#) (414-00 Battery and Charging System - General Information, Specifications).

27. Check and top-up the transfer case fluid level.

28. Check and top-up the transmission fluid level.

For additional information, refer to: [Transmission Fluid Level Check](#) (307-01B Automatic Transmission/Transaxle - V6 4.0L Petrol, General Procedures).

29. Lower the vehicle.

Automatic Transmission/Transaxle - V6 4.0L Petrol -

Lubricants

Item	Specification
* Recommended lubricant	ATF Shell M13754
+ Torque converter nose	Molybdenum disulphide grease to specification FB180

• CAUTIONS:



* Do not use any lubricant other than that specified.



+ Do not over lubricate.

Capacity

Item	Capacity
+ Initial dry fill	9.5 litres (16.7 pints) (10.0 US qts)



CAUTION: + A final oil level check/top-up must be carried out when the unit has been installed.

General Specification

Item	Specification
Automatic transmission	ZF 6HP26
Speeds	6 Forward, 1 Reverse
Gear ratios:	
First	4.17:1
Second	2.340:1
Third	1.521:1
Fourth	1.143:1
Fifth	0.867:1
Sixth	0.691:1
Reverse	3.403:1
Torque converter	Sachs W260 2GWK with slip controlled, dual friction faced lock-up clutch
Transmission control module:	
Location	Located in gearbox casing
Type	1904

Torque Specifications

Description	Nm	lb-ft
Transmission heat shield bolts	10	7
Transmission heat shield bracket bolts	10	7
Fuel pipe heat shield bracket bolts	10	7
Selector cable bracket nut	12	9
Transmission control module Torx screws	8	6
Main control valve body Torx screws	8	6
Fluid pan Torx screws	8	6
Engine RH support nut	90	66
Transmission support insulator bolts	60	44
Selector shaft nut	12	9
Selector cable bracket bolts	10	7
Flexplate to torque converter bolts	45	33
Transmission bolts	45	33
Transmission breather pipe clip bolt	25	18
Transmission fluid lines clip bolt	10	7

Automatic Transmission/Transaxle - V6 4.0L Petrol - Automatic Transmission

Description and Operation

ZF 6HP26 Automatic Transmission Component Location

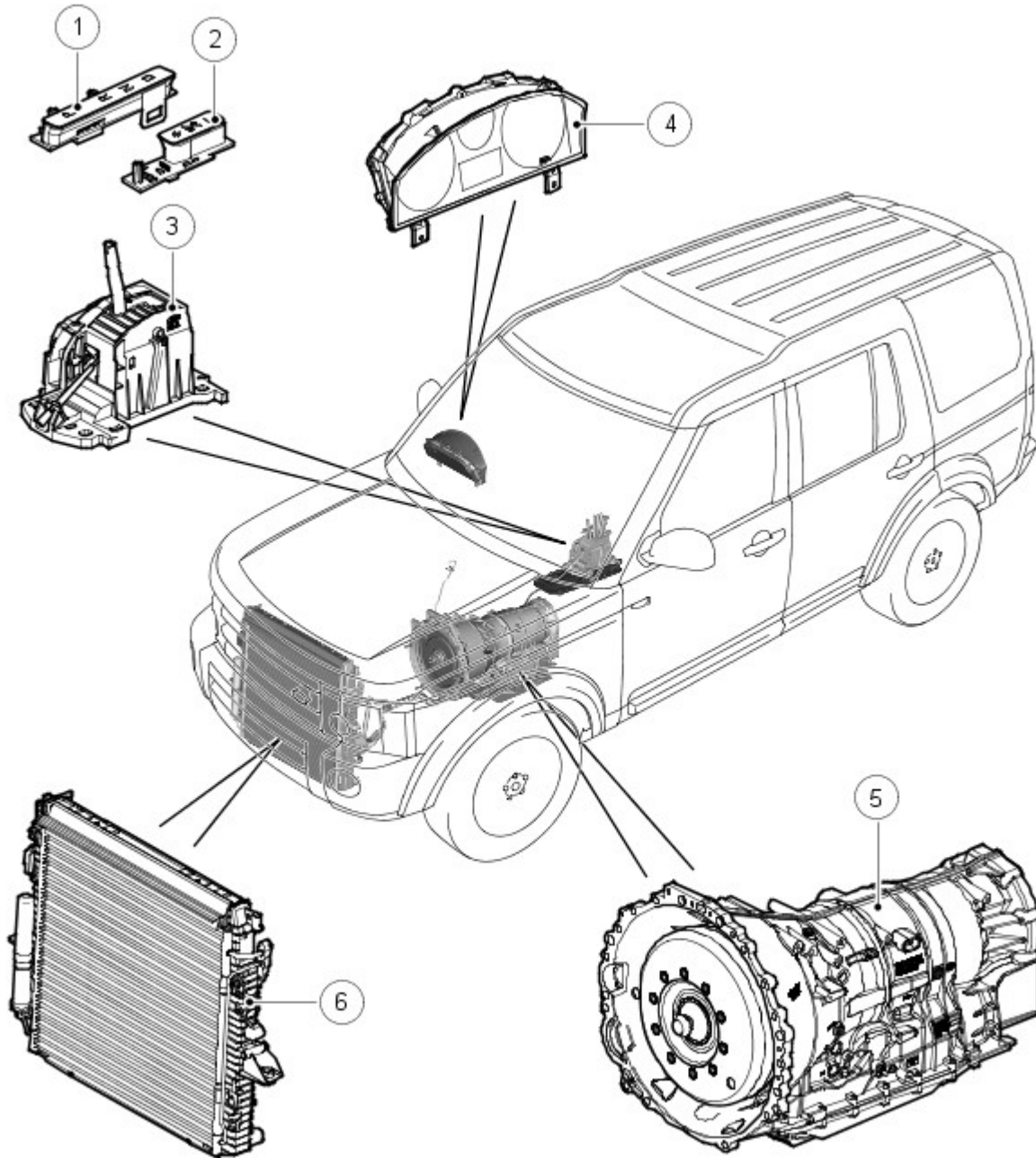

E42389

Item	Part Number	Description
1	-	PRND LCD display
2	-	M/S LCD display
3	-	Selector lever assembly
4	-	Instrument cluster
5	-	Automatic transmission
6	-	Transmission fluid cooler

GENERAL

The ZF 6HP26 transmission is an electronically controlled, six speed unit. The transmission is manufactured by ZF Transmissions GmbH in Saarbrücken, Germany. This transmission represents the latest in automatic transmission technology and incorporates new features to enhance the transmission functionality:

- The hydraulic and electronic control elements of the transmission are now incorporated in a single unit located inside the transmission and is known as 'Mechatronic'
- Another new strategy is Adaptive Shift Strategy (ASIS). ASIS represents the continuous adaptation of shift changes to suit the driving style of the driver which can vary from sporting to economical. Further details of the ASIS

function are contained in the 'Driving Modes' section.

The transmission is controlled by an Transmission Control Module (TCM) which contains software to provide operation as a semi-automatic 'CommandShift™' transmission. The TCM allows the transmission to be operated as a conventional automatic unit by selecting P, R, N, D on the selector lever. Movement of the selector lever across the gate to the 'M/S' position puts the transmission into electronic 'Sport' mode. Further movement of the lever in a lateral direction to the + or - position puts the transmission into electronic manual 'CommandShift™' mode.

The 6HP26 transmission has the following features:

- Designed to be maintenance free
- Transmission fluid is 'fill for life'
- The torque converter features a controlled slip feature with electronically regulated control of lock-up, creating a smooth transition to the fully locked condition
- Shift programs controlled by the TCM
- Connected to the ECM via the High Speed CAN for communications
- Default mode if major faults occur
- Diagnostics available from the TCM via the CAN.

ZF 6HP26 Automatic Transmission – Exploded View

- NOTE: The transmission shown is exploded to the extent of the serviceable items

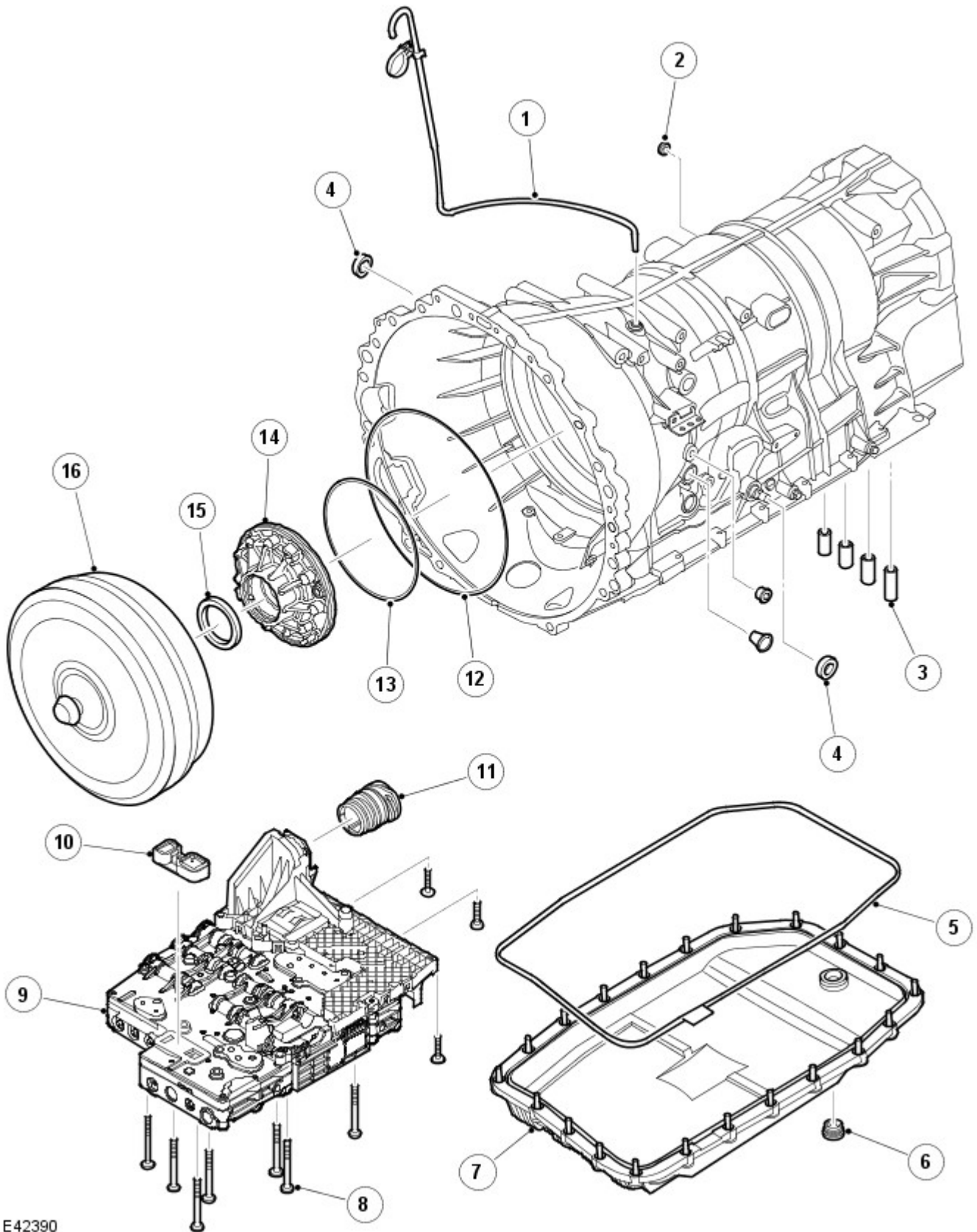

E42390

Item	Part Number	Description
1	-	Breather tube
2	-	Plug
3	-	Seal sleeves
4	-	Seal - Selector shaft (2 off)
5	-	Gasket
6	-	Drain plug
7	-	Fluid pan
8	-	Torx screws
9	-	Mechatronic valve block
10	-	Element seal
11	-	Electrical connector - guide sleeve

12	-	O-ring
13	-	O-ring
14	-	Pump housing (not a serviceable component)
15	-	Input shaft seal
16	-	Torque converter

The gearbox comprises the main casing which houses all of the transmission components. The main case also incorporates an integral bell housing.

A fluid pan is bolted to the lower face of the main case and is secured with bolts. The fluid pan is sealed to the main case with a gasket. Removal of the fluid pan allows access to the Mechatronic valve block. The fluid pan has a magnet located around the drain plug which collects any metallic particles present in the transmission fluid.

A fluid filter is located inside the fluid pan. If the transmission fluid becomes contaminated or after any service work, the fluid pan with integral filter must be replaced.



CAUTION: Take care when removing the fluid pan and/or replacing the Mechatronic valve block that neither the fluid pan gasket or the mating face on the transmission casing is damaged or leakage may occur. Do not use metal tools to prise the fluid pan from the transmission casing. Take care when positioning a new mechatronic unit to ensure it does not contact the casing face.

The integral bell housing provides protection for the torque converter assembly and also provides the attachment for the gearbox to the engine cylinder block. The torque converter is a non-serviceable assembly which also contains the lock-up clutch mechanism. The torque converter drives a crescent type pump via drive tangs. The fluid pump is located in the main case, behind the torque converter.

The main case contains the following major components:

- Input shaft
- Output shaft
- Mechatronic valve block which contains the solenoids, speed sensors and the TCM
- Three rotating multiplate drive clutches
- Two fixed multiplate brake clutches
- A single planetary gear train and a double planetary gear train.

ZF 6HP26 Automatic Transmission – Sectional View

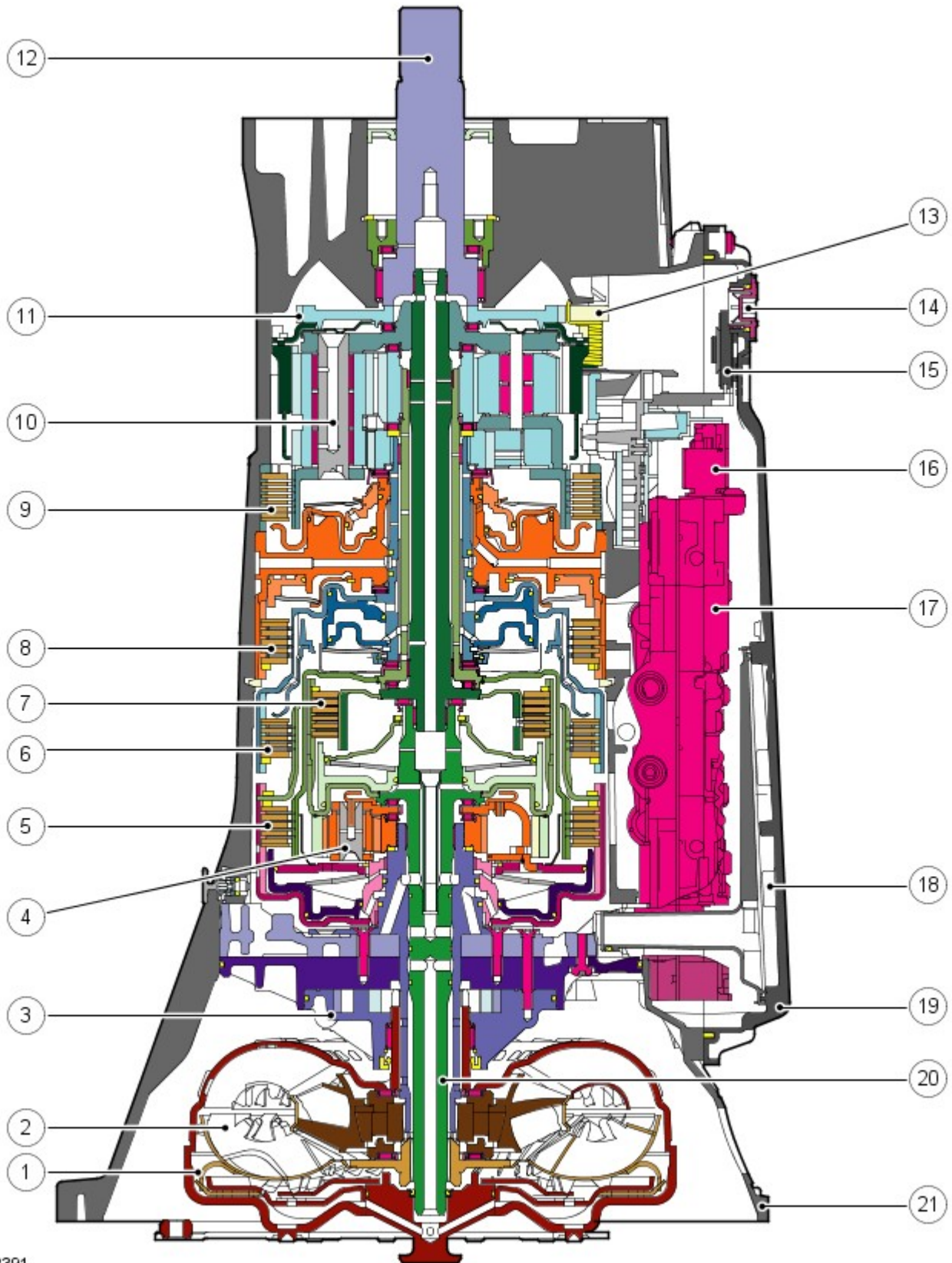

E42391

Item	Part Number	Description
1	-	Torque converter lock-up clutch
2	-	Torque converter
3	-	Fluid pump
4	-	Single planetary gearset
5	-	Clutch A
6	-	Clutch B
7	-	Clutch E
8	-	Brake C
9	-	Brake D
10	-	Double planetary gearset
11	-	Park lock gear

12	-	Output shaft
13	-	Park lock pawl
14	-	Drain plug
15	-	Magnet
16	-	Pressure regulator
17	-	Mechatronic valve block
18	-	Fluid filter
19	-	Fluid pan
20	-	Input shaft
21	-	Transmission casing

TORQUE CONVERTER

Torque Converter Components - 4.0L V6 and 4.4L V8 Models

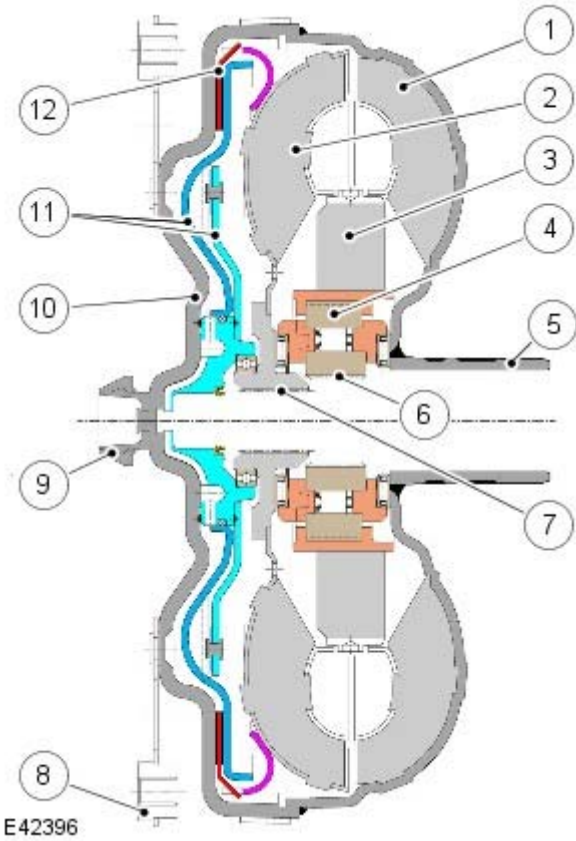

Item	Part Number	Description
1	-	Impeller
2	-	Turbine
3	-	Stator
4	-	Freewheel
5	-	Torque converter hub
6	-	Stator shaft
7	-	Turbine shaft
8	-	Drive plate
9	-	Journal - Drive plate location
10	-	Torque converter cover
11	-	Lock-up clutch piston
12	-	Lock-up clutch plate

Torque Converter Components - TdV6 Models

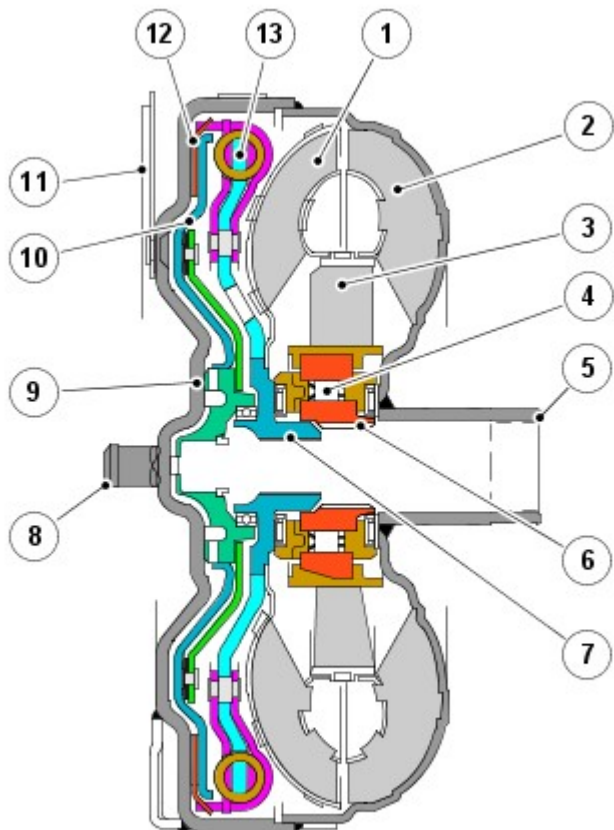

E42740

Item	Part Number	Description
1	-	Turbine
2	-	Impeller
3	-	Stator
4	-	Freewheel
5	-	Torque converter hub
6	-	Stator shaft
7	-	Turbine shaft
8	-	Journal - Drive plate location
9	-	Torque converter cover
10	-	Lock-up clutch piston
11	-	Drive plate
12	-	Lock-up clutch plate
13	-	Torsional vibration damper

The torque converter is the coupling element between the engine and the gearbox and is located in the transmission housing, on the engine side of the transmission. The driven power from the engine crankshaft is transmitted hydraulically and mechanically through the torque converter to the transmission. The torque converter is connected to the engine by a drive plate.

The torque converter comprises an impeller, a stator and a turbine. The torque converter is a sealed unit with all components located between the converter housing cover and the impeller. The two components are welded together to form a sealed, fluid filled housing. With the impeller welded to the converter housing cover, the impeller is therefore driven at engine crankshaft speed.

The converter housing cover has threaded bosses which provide for attachment of the engine drive plate which is connected to the engine crankshaft. The threaded bosses also provide for location of special tools which are required to remove the torque converter from the bell housing.

The torque converter used on TdV6 models is similar in construction to the torque converter on petrol models but contains a torsional vibration damper. The damper smooths the output from the engine and prevents unwanted vibration from being passed to the transmission.

Impeller

Fluid Flow

- NOTE: Typical torque converter shown

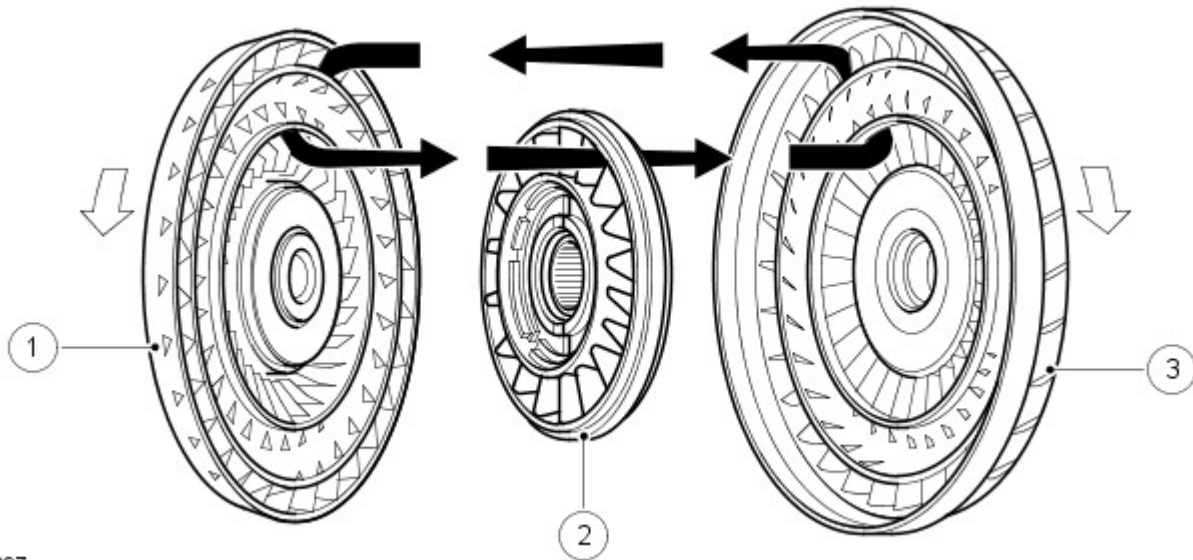

E42397

Item	Part Number	Description
1	-	Turbine
2	-	Stator
3	-	Impeller

When the engine is running the rotating impeller acts as a centrifugal pump, picking up fluid at its centre and discharging it at high velocity through the blades on its outer rim. The design and shape of the blades and the curve of the impeller body cause the fluid to rotate in a clockwise direction as it leaves the impeller. This rotation improves the efficiency of the fluid as it contacts the outer row of blades on the turbine.

The centrifugal force of the fluid leaving the blades of the impeller is passed to the curved inner surface of the turbine via the tip of the blades. The velocity and clockwise rotation of the fluid causes the turbine to rotate.

Turbine

The turbine is similar in design to the impeller with a continuous row of blades. Fluid from the impeller enters the turbine through the tip of the blades and is directed around the curved body of the turbine to the root of the blades. The curved surface redirects the fluid back in the opposite direction to which it entered the turbine, effectively increasing the turning force applied to the turbine from the impeller. This principle is known as torque multiplication.

When engine speed increases, turbine speed also increases. The fluid leaving the inner row of the turbine blades is rotated in an anti-clockwise direction due to the curve of the turbine and the shape of the blades. The fluid is now flowing in the opposite direction to the engine rotation and therefore the impeller. If the fluid was allowed to hit the impeller in this condition, it would have the effect of applying a brake to the impeller, eliminating the torque multiplication effect. To prevent this, the stator is located between the impeller and the turbine.

Stator

The stator is located on the splined transmission input shaft via a freewheel clutch. The stator comprises a number of blades which are aligned in an opposite direction to those of the impeller and turbine. The main function of the stator is to redirect the returning fluid from the turbine, changing its direction to that of the impeller.

The redirected fluid from the stator is directed at the inner row of blades of the impeller, assisting the engine in turning the impeller. This sequence increases the force of the fluid emitted from the impeller and thereby increases the torque multiplication effect of the torque converter.

Stator Functions

- NOTE: Typical stator shown

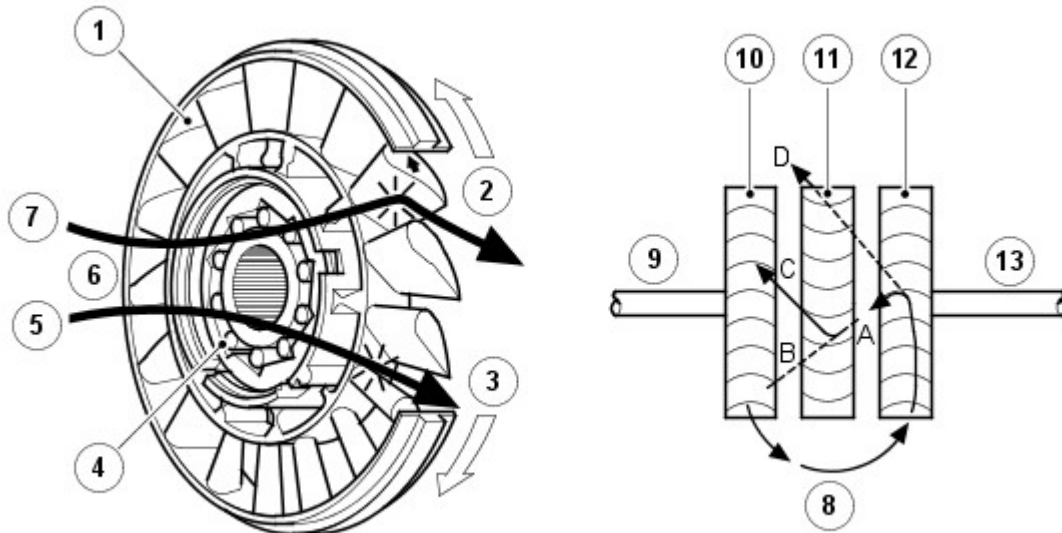

E 42398

Item	Part Number	Description
1	-	Blades
2	-	Stator held – fluid flow redirected
3	-	Stator rotates freely
4	-	Roller
5	-	Converter at coupling speed
6	-	Fluid flow from turbine
7	-	Converter multiplying
8	-	Fluid flow from impeller
9	-	Drive from engine
10	-	Impeller
11	-	Stator
12	-	Turbine
13	-	Output to transmission

Refer to the 'Stator Functions' illustration

Fluid emitted from the impeller acts on the turbine. If the turbine is rotating at a slower speed than the fluid from the impeller, the fluid will be deflected by the turbine blades in the path 'A'. The fluid is directed at and deflected by the stator blades from path 'B' to path 'C'. This ensures that the fluid is directed back to the pump in the optimum direction. In this condition the sprag clutch is engaged and the force of the fluid on the stator blades assists the engine in rotating the impeller

As the rotational speed of the engine and therefore the turbine increases, the direction of the fluid leaving the turbine changes to path 'D'. The fluid is now directed from the turbine to the opposite side of the stator blades, rotating the stator in the opposite direction. To prevent the stator from resisting the smooth flow of the fluid from the turbine, the sprag clutch releases, allowing the stator to rotate freely on its shaft.

When the stator becomes inactive, the torque converter no longer multiplies the engine torque. When the torque converter reaches this operational condition it ceases to multiply the engine torque and acts solely as a fluid coupling, with the impeller and the turbine rotating at approximately the same speed.

The stator uses a sprag type, one way, freewheel clutch. When the stator is rotated in a clockwise direction the sprags twist and are wedged between the inner and outer races. In this condition the sprags transfer the rotation of the outer race to the inner race which rotates at the same speed.

One Way Free Wheel Clutch – Typical

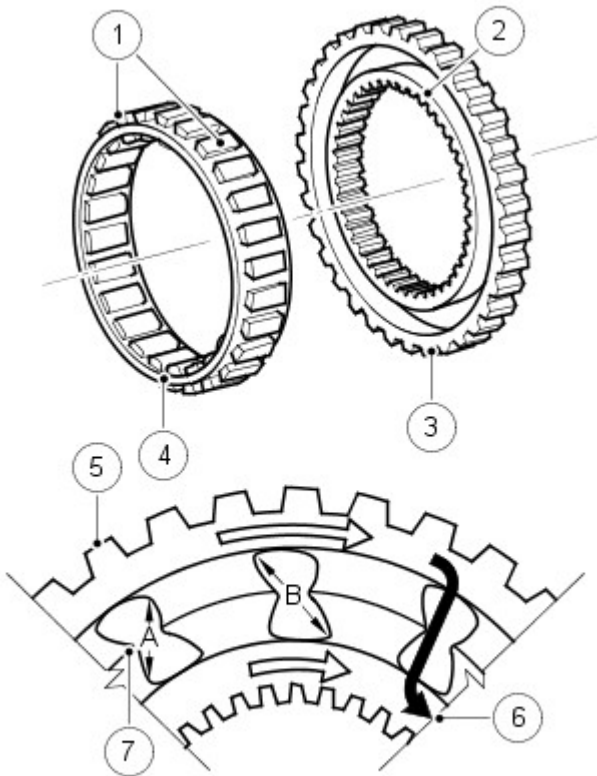

E 42712

Item	Part Number	Description
1	-	Sprags
2	-	Inner race
3	-	Outer race
4	-	Sprag and cage assembly
5	-	Sprag outer race
6	-	Sprag inner race
7	-	Retaining ring

The free wheel clutch can perform three functions; hold the stator stationary, drive the stator and free wheel allowing the stator to rotate without a drive output. The free wheel clutch used in the 6HP26 transmission is of the sprag type and comprises an inner and outer race and a sprag and cage assembly. The inner and outer races are pressed into their related components with which they rotate. The sprag and cage assembly is located between the inner and outer races.

The sprags are located in a cage which is a spring which holds the sprags in the 'wedge' direction and maintains them in contact with the inner and outer races.

Referring to the illustration, the sprags are designed so that the dimension 'B' is larger than the distance between the inner and outer race bearing surfaces. When the outer race rotates in a clockwise direction, the sprags twist and the edges across the dimension 'B' wedge between the races, providing a positive drive through each sprag to the inner race. The dimension 'A' is smaller than the distance between the inner and outer race bearing surfaces. When the outer race rotates in an anti-clockwise direction, the dimension 'A' is too small to allow the sprags to wedge between the races, allowing the outer race to rotate freely.

On the illustration shown, when the outer race is rotated in a clockwise direction, the sprags twist and are 'wedged' between the inner and outer races. The sprags then transfer the rotation of the outer race to the inner race, which rotates at the same speed.

Lock-Up Clutch Mechanism

The Torque Converter Clutch (TCC) is hydraulically controlled by an electronic pressure regulating solenoid (EPRS6) which is controlled by the TCM. This allows the torque converter to have three states of operation as follows:

- Fully engaged
- Controlled slip variable engagement
- Fully disengaged

The TCC is controlled by two hydraulic spool valves located in the valve block. These valves are actuated by pilot pressure supplied via a solenoid valve which is also located in the valve block. The solenoid valve is operated by PWM signals from the TCM to give full, partial or no lock-up of the torque converter.

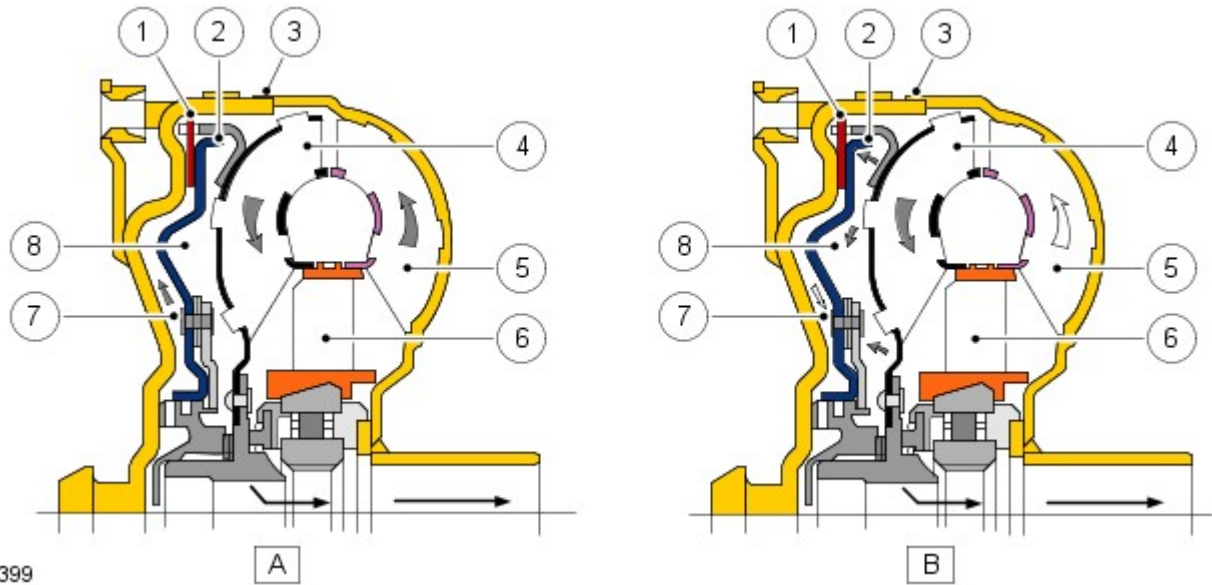

E 42399

Item	Part Number	Description
A	-	Unlocked condition
B	-	Locked condition
1	-	Clutch plate
2	-	Clutch piston
3	-	Torque converter body
4	-	Turbine
5	-	Impeller
6	-	Stator
7	-	Piston chamber
8	-	Turbine chamber

The lock-up clutch is a hydro-mechanical device which eliminates torque converter slip, improving fuel consumption. The engagement and disengagement is controlled by the TCM to allow a certain amount of controlled 'slip'. This allows a small difference in the rotational speeds of the impeller and the turbine which results in improved shift quality. The lock-up clutch comprises a piston and a clutch friction plate.

In the unlocked condition, the oil pressure supplied to the piston chamber and the turbine chamber is equal. Pressurised fluid flows through a drilling in the turbine shaft and through the piston chamber to the turbine chamber. In this condition the clutch plate is held away from the torque converter body and torque converter slip is permitted.

In the locked condition, the TCC spool valves are actuated by the electronic pressure regulating solenoid (EPRS6). The fluid flow in the unlocked condition is reversed and the piston chamber is vented. Pressurised fluid is directed into the turbine chamber and is applied to the clutch piston. The piston moves with the pressure and pushes the clutch plate against the torque converter body. As the pressure increases, the friction between the clutch plate and the body increases, finally resulting in full lock-up of the clutch plate with the body. In this condition there is direct mechanical drive from the engine crankshaft to the transmission planetary gear train.

FLUID PUMP

The fluid pump is an integral part of the transmission. The fluid pump is used to supply hydraulic pressure for the operation of the control valves and clutches and also to pass the fluid through the transmission cooler.

The 6HP26 fluid pump is a crescent type pump and is located between the intermediate plate and the torque converter. The pump has a delivery rate of 16cm³ per revolution.

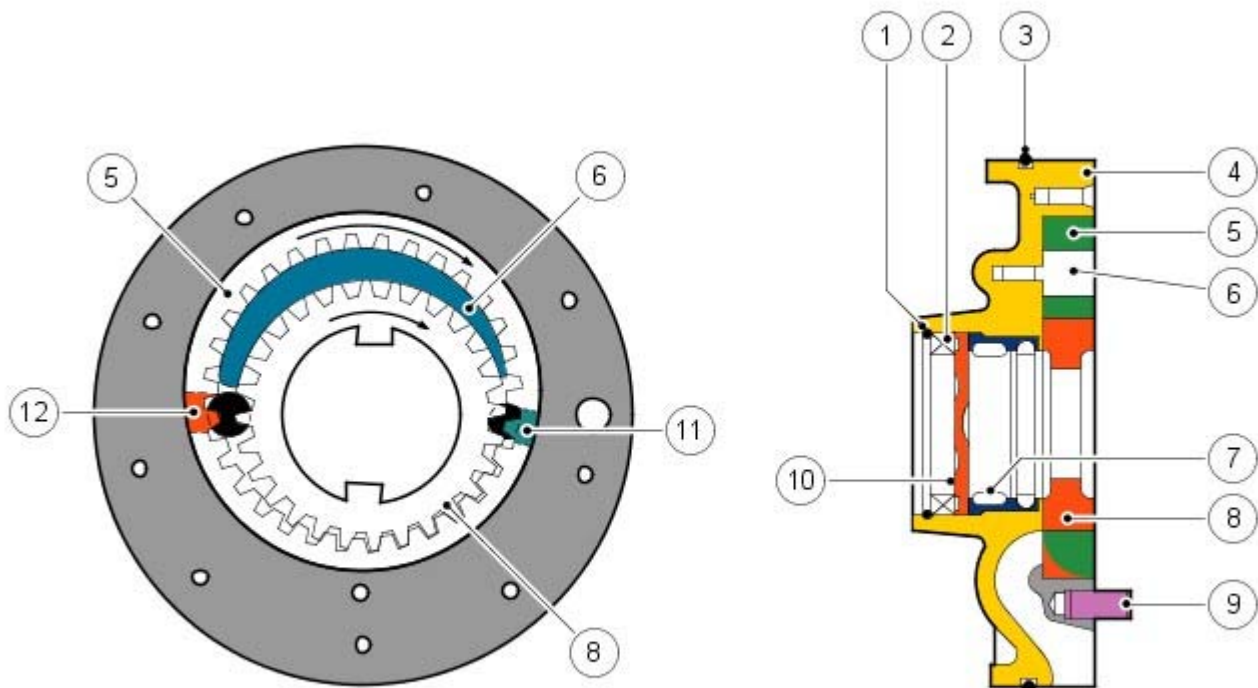

E42400

Item	Part Number	Description
1	-	Securing ring
2	-	Shaft oil seal
3	-	O-ring seal
4	-	Pump housing
5	-	Ring gear
6	-	Crescent spacer
7	-	Roller bearing
8	-	Impeller
9	-	Centring pin
10	-	Spring washer
11	-	Outlet port (high pressure)
12	-	Inlet port (low pressure)

The pump comprises a housing, a crescent spacer, an impeller and a ring gear. The housing has inlet and outlet ports to direct flow and is located in the intermediate plate by a centring pin. The pump action is achieved by the impeller, ring gear and crescent spacer.

The crescent spacer is fixed in its position by a pin and is located between the ring gear and the impeller. The impeller is driven by drive from the torque converter which is located on a needle roller bearing in the pump housing. The impeller teeth mesh with those of the ring gear. When the impeller is rotated, the motion is transferred to the ring gear which rotates in the same direction.

The rotational motion of the ring gear and the impeller collects fluid from the intake port in the spaces between the teeth. When the teeth reach the crescent spacer, the oil is trapped in the spaces between the teeth and is carried with the rotation of the gears. The spacer tapers near the outlet port. This reduces the space between the gear teeth causing a build up of fluid pressure as the oil reaches the outlet port. When the teeth pass the end of the spacer the pressurised fluid is passed to the outlet port.

The fluid emerging from the outlet port is passed through the fluid pressure control valve. At high operating speeds the pressure control valve maintains the output pressure to the gearbox at a predetermined maximum level. Excess fluid is relieved from the pressure control valve and is directed, via the main pressure valve in the valve block, back to the pump inlet port. This provides a pressurised feed to the pump inlet which prevents cavitation and reduces pump noise.

MECHATRONIC VALVE BLOCK

The Mechatronic valve block is located in the bottom of the transmission and is covered by the fluid pan. The valve block houses the TCM, electrical actuators, speed sensors and control valves which provide all electro-hydraulic control for all transmission functions. The Mechatronic valve block comprises the following components:

- TCM
- Six pressure regulator solenoids
- One shift control solenoid
- One damper
- Twenty one hydraulic spool valves
- Manually operated selector valve
- Temperature sensor

- Turbine speed sensor
- Output shaft speed sensor.

A radio interference suppressor is located on a bracket on the right hand side of the transmission, forward of the selector shaft lever. The suppressor is connected into the transmission wiring harness and prevents solenoid operating noise affecting the audio system.

ZF 6HP26 Automatic Transmission – Mechatronic Valve Block

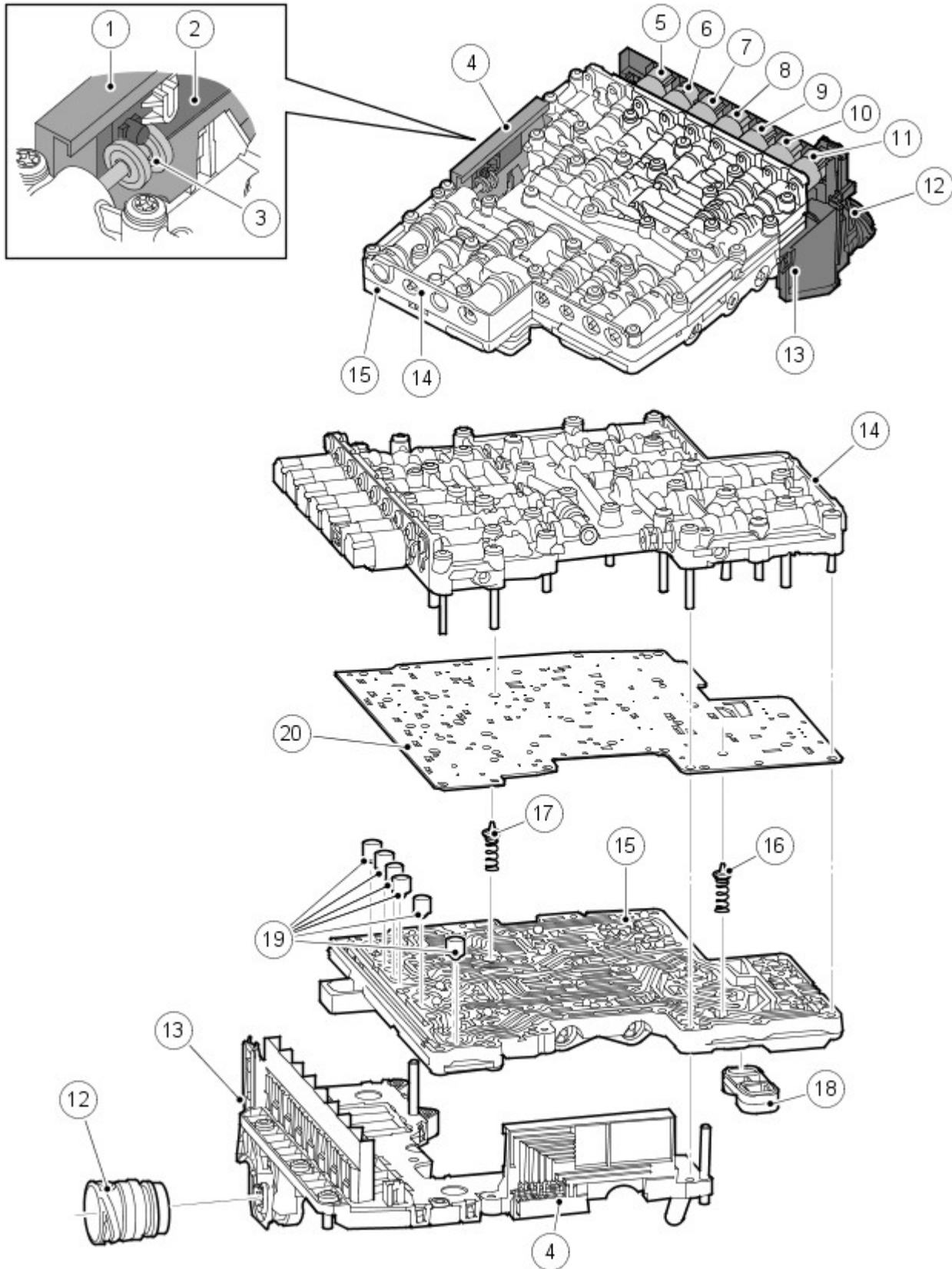

E42392

Item	Part Number	Description
1	-	Position switch
2	-	Sliding block
3	-	Selector spool valve

4	-	Position switch assembly
5	-	Electronic Pressure Regulator Solenoid (EPRS) 6
6	-	Solenoid Valve 1
7	-	EPRS 4
8	-	EPRS 5
9	-	EPRS 3
10	-	EPRS 2
11	-	EPRS 1
12	-	Electrical connector
13	-	Transmission Control Module (TCM)
14	-	Valve housing
15	-	Valve plate
16	-	Torque converter retaining valve
17	-	Clutch return valve
18	-	Element seal
19	-	Pressure regulator dampers
20	-	Intermediate plate

ZF 6HP26 Automatic Transmission – Valve Housing Components

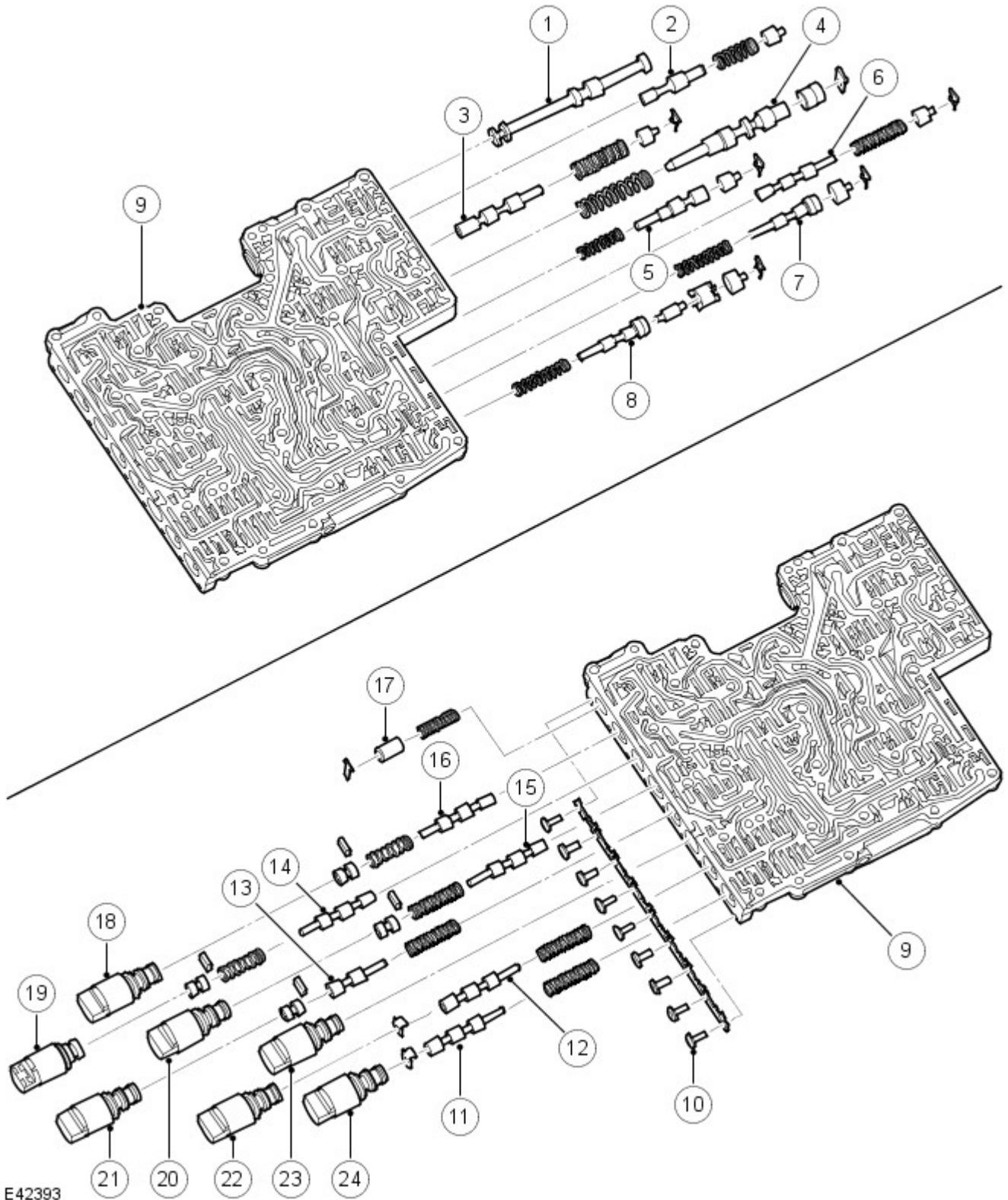

E42393

Item	Part Number	Description
1	-	Selector spool valve
2	-	Lubricating valve
3	-	Torque converter pressure valve
4	-	System pressure valve
5	-	Torque converter clutch valve
6	-	Retaining valve - Clutch E
7	-	Clutch valve E
8	-	Clutch valve A
9	-	Valve housing
10	-	Bolts
11	-	Retaining valve - Clutch A

12	-	Retaining valve – Clutch B
13	-	Pressure reducing valve
14	-	Shift valve 1
15	-	Retaining valve – Brake D
16	-	Shift valve 2
17	-	Damper
18	-	Electronic Pressure Regulator Solenoid (EPRS) 6
19	-	Solenoid valve 1
20	-	EPRS 4
21	-	EPRS 5
22	-	EPRS 2
23	-	EPRS 3
24	-	EPRS 1

ZF 6HP26 Automatic Transmission – Valve Plate Components

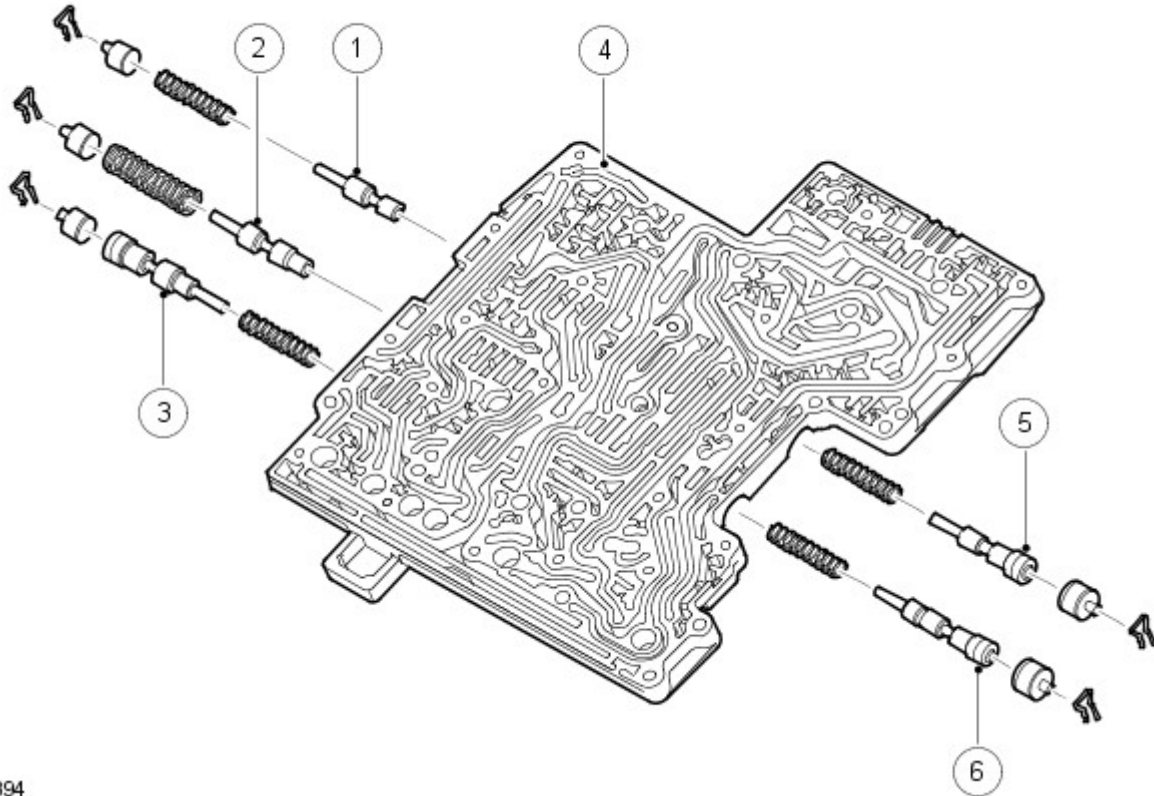

E42394

Item	Part Number	Description
1	-	Retaining valve – Brake D2
2	-	Clutch valve – Brake D2
3	-	Clutch valve B
4	-	Valve plate
5	-	Clutch valve – Brake D1
6	-	Clutch valve – Brake C

Electronic Pressure Regulator Solenoids (EPRS)

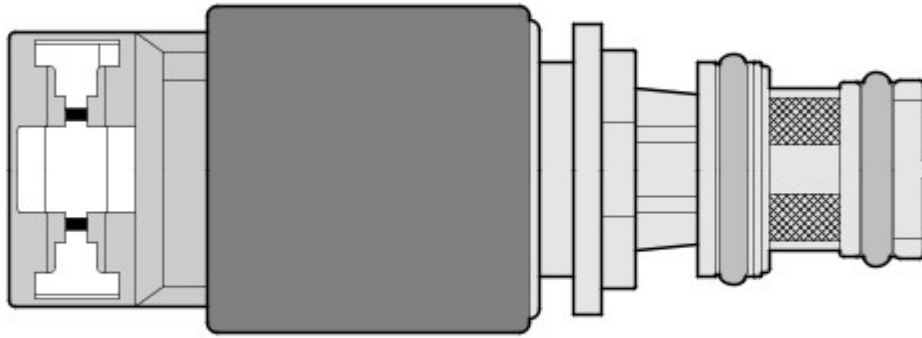

E42713

Six Electronic Pressure Regulator Solenoids (EPRS) are located in the valve block. The solenoids are controlled by Pulse width Modulation (PWM) signals from the TCM. The solenoids convert the electrical signals into hydraulic control pressure proportional to the signal to actuate the spool valves for precise transmission operation.

The following table shows EPRS and their associated functions:

EPRS	Function
1	Clutch A
2	Clutch B
3	Clutch C
4	Brake clutches D and E
5	System pressure control
6	Torque converter lock-up control

Solenoids EPRS 1, 3 and 6 supply a lower control pressure as the signal amperage increases and can be identified by a black connector cap. The TCM operates the solenoids using PWM signals. The TCM monitors engine load and clutch slip and varies the solenoid duty cycle accordingly. The solenoids have a 12V operating voltage and a pressure range of 0 - 4.6 bar (0 - 67 lbf.in²).

Solenoids EPRS 2, 4 and 5 supply a higher control pressure as the signal amperage increases and can be identified by a green connector cap. The solenoids are normally open, regulating flow solenoid valves. The TCM operates the solenoids using a PWM earth proportional to the required increasing or decreasing clutch pressures. The solenoids have a 12V operating voltage and a pressure range of 4.6 - 0 bar (67 - 0 lbf.in²).

The resistance of the coil winding for the EPRS solenoids is 5.05 ohms at 20°C (68°F).

Control Solenoid



E42714

A shift control Solenoid Valve (SV) is located in the valve block. The solenoid is controlled by the TCM and converts electrical signals into hydraulic control signals to control clutch application.

The shift control solenoid is an open/closed, on/off solenoid which is controlled by the TCM switching the solenoid to earth. The TCM also supplies power to the solenoid. The TCM energises the solenoid in a programmed sequence for clutch application for gear ratio changes and shift control.

The resistance of the solenoid coil winding for solenoid is between 26 to 30.4 ohms at 20°C (68°F).

Sensors

Speed Sensors

The turbine speed sensor and the output shaft speed sensor are Hall effect type sensors located in the Mechatronic valve block and are not serviceable items. The TCM monitors the signals from each sensor to determine the input (turbine) speed and the output shaft speed.

The turbine speed is monitored by the TCM to calculate the slip of the torque converter clutch and internal clutch slip. This signal allows the TCM to accurately control the slip timing during shifts and adjust clutch application or release pressure for overlap shift control.

The output shaft speed is monitored by the TCM and compared to engine speed signals received on the CAN bus from the ECM. Using a comparison of the two signals the TCM calculates the transmission slip ratio for plausibility and maintains adaptive pressure control.

Temperature Sensor

The temperature sensor is also located in the Mechatronic valve block. The TCM uses the temperature sensor signals to determine the temperature of the transmission fluid. These signals are used by the TCM to control the transmission operation to promote faster warm-up in cold conditions or to assist with fluid cooling by controlling the transmission operation when high fluid temperatures are experienced. If the sensor fails, the TCM will use a default value and a fault code will be stored in the TCM.

Damper

There is one damper located in the valve housing. The damper is used to regulate and dampen the regulated pressure supplied via EPRS 5. The damper is load dependent through modulation of the damper against return spring pressure.

The damper comprises a piston, a housing bore and a spring. The piston is subject to the pressure applied by the spring. The bore has a connecting port to the function to which it applies. Fluid pressure applied to the applicable component (i.e. a clutch) is also subjected to the full area of the piston, which moves against the opposing force applied by the spring. The movement of the piston creates an action similar to a shock absorber, momentarily delaying the build up of pressure in the circuit. This results in a more gradual application of clutches improving shift quality.

Spool Valves

The valve block contains twenty one spool valves which control various functions of the transmission. The spool valves are of conventional design and are operated by fluid pressure.

Each spool valve is located in its spool bore and held in a default (unpressurised) position by a spring. The spool bore has a number of ports which allow fluid to flow to other valves and clutches to enable transmission operation. Each spool has a piston which is waisted to allow fluid to be diverted into the applicable ports when the valve is operated.

When fluid pressure moves a spool, one or more ports in the spool bore are covered or uncovered. Fluid is prevented from flowing or is allowed to flow around the applicable waisted area of the spool and into another uncovered port. The fluid is either passed through galleries to actuate another spool, operate a clutch or is returned to the fluid pan.

DRIVE CLUTCHES

Multiplate Drive or Brake Clutch – Typical

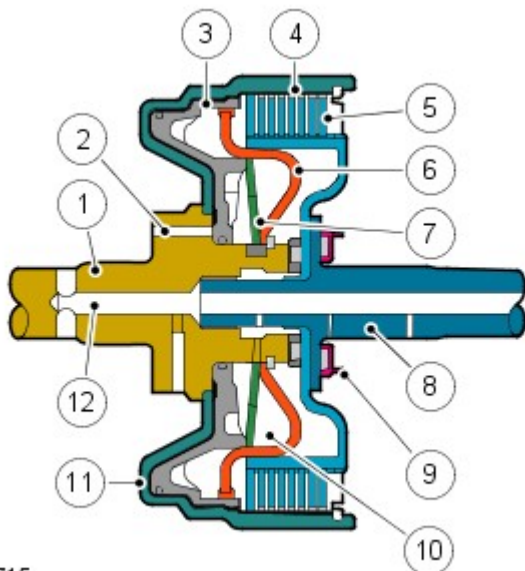

E42715

Item	Part Number	Description
1	-	Input shaft
2	-	Main pressure supply port
3	-	Piston
4	-	Cylinder – External plate carrier
5	-	Clutch plate assembly
6	-	Baffle plate
7	-	Diaphragm spring
8	-	Output shaft
9	-	Bearing

10	-	Dynamic pressure equalisation chamber
11	-	Piston chamber
12	-	Lubrication channel

There are three drive clutches and two brake clutches used in the 6HP26 transmission. Each clutch comprises one or more friction plates dependent on the output controlled. A typical clutch consists of a number of steel outer plates and inner plates with friction material bonded to each face.

The clutch plates are held apart mechanically by a diaphragm spring and hydraulically by dynamic pressure. The pressure is derived from a lubrication channel which supplies fluid to the bearings etc. The fluid is passed via a drilling in the output shaft into the chamber between the baffle plate and the piston. To prevent inadvertent clutch application due to pressure build up produced by centrifugal force, the fluid in the dynamic pressure equalisation chamber overcomes any pressure in the piston chamber and holds the piston off the clutch plate assembly.

When clutch application is required, main pressure from the fluid pump is applied to the piston chamber from the supply port. This main pressure overcomes the low pressure fluid present in the dynamic pressure equalisation chamber. The piston moves, against the pressure applied by the diaphragm spring, and compresses the clutch plate assembly. When the main pressure falls, the diaphragm spring pushes the piston away from the clutch plate assembly, disengaging the clutch.

PLANETARY GEAR TRAINS

The planetary gear trains used on the 6HP26 transmission comprise a single web planetary gear train and a double web planetary gear train. These gear trains are known as Lepelletier type gear trains and together produce the six forward gears and the one reverse gear.

Single Web Planetary Gear Train

The single web planetary gear train comprises:

- One sunwheel
- Three planetary gears
- One planetary gear carrier
- One ring gear or annulus

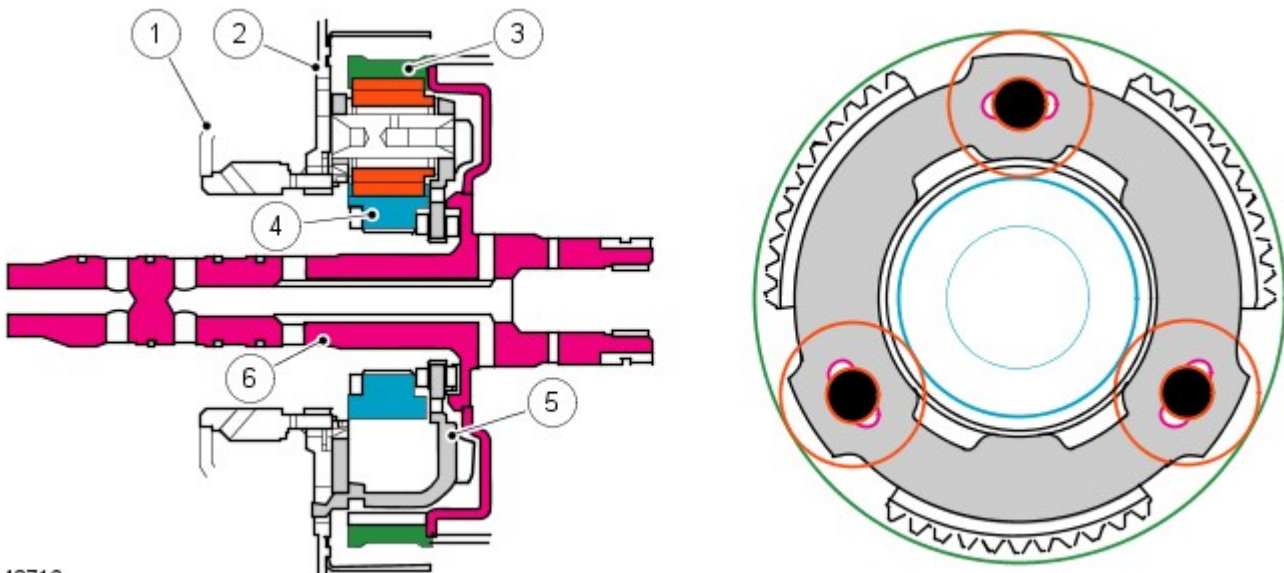

E42716

Item	Part Number	Description
1	-	Cylinder
2	-	Baffle plate
3	-	Ring gear
4	-	Planetary gear carrier
5	-	Planetary gear spider
6	-	Torque converter input shaft

Double Web Planetary Gear Train

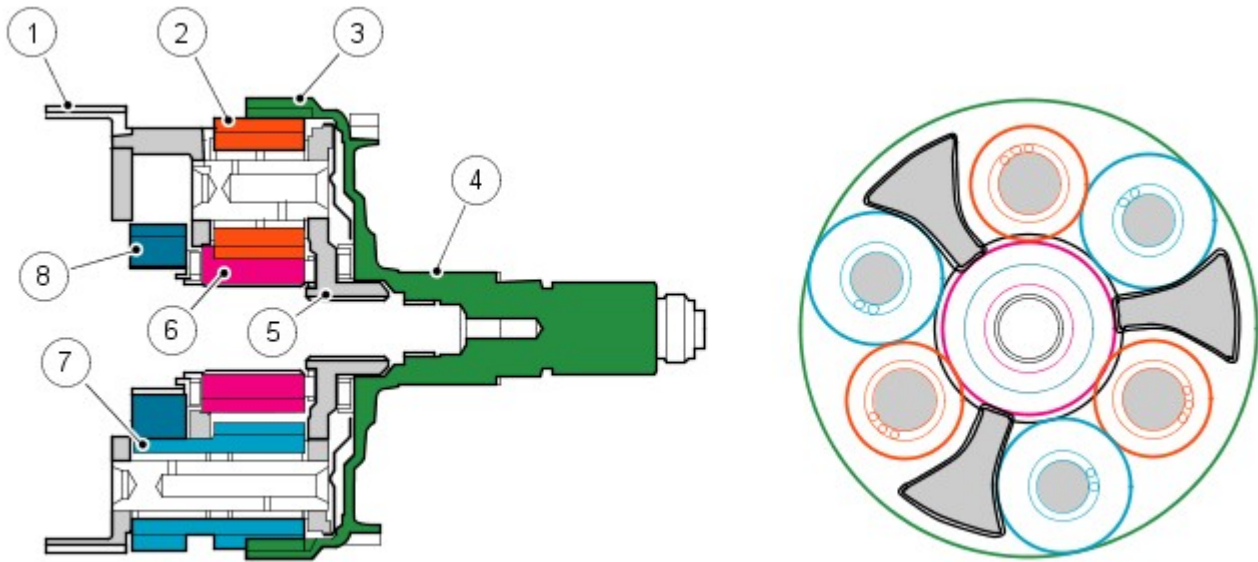

E42717

Item	Part Number	Description
1	-	Planetary gear spider
2	-	Planetary gears (short)
3	-	Ring gear
4	-	Output shaft
5	-	Planetary gear
6	-	Sunwheel
7	-	Double planetary gears (long)
8	-	Sunwheel

The double planetary gear train comprises:

- Two sunwheels
- Three short planetary gears
- Three long planetary gears
- One planetary gear carrier
- One ring gear or annulus

POWER FLOWS

Operation of the transmission is controlled by the TCM which electrically activates various solenoids to control the transmission gear selection. The sequence of solenoid activation is based on programmed information in the module memory and physical transmission operating conditions such as vehicle speed, throttle position, engine load and selector lever position.

Powerflow Schematic

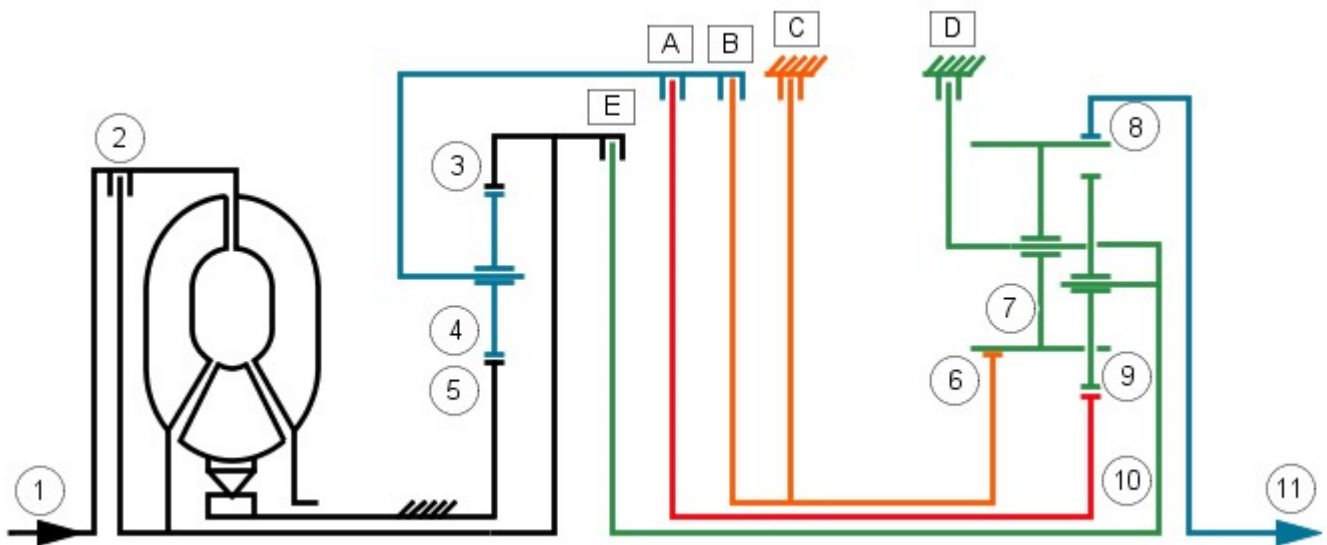

E42718

Item	Part Number	Description
1	-	Torque input from engine
2	-	Torque converter lock-up clutch
3	-	Single web planetary gear carrier

4	-	Single web planetary gears
5	-	Single web sunwheel 1
6	-	Double web sunwheel 2
7	-	Double web planetary gears - Long
8	-	Double web planetary gear carrier
9	-	Double web planetary gears - Short
10	-	Double web sunwheel 3
11	-	Torque output from transmission
A	-	Multiplate clutch
B	-	Multiplate clutch
C	-	Multiplate brake
D	-	Multiplate brake
E	-	Multiplate clutch

Engine torque is transferred, via operation of single or combinations of clutches to the two planetary gear trains. Both gear trains are controlled by reactionary inputs from brake clutches to produce the six forward gears and one reverse gear. The ratios are as follows:

Gear	1st	2nd	3rd	4th	5th	6th	Reverse
Ratio	4.171	2.340	1.521	1.143	0.867	0.691	3.403

The following table shows which solenoids are activated to produce the required torque output from the transmission.

Gear Selector Lever Position	Shift Control Solenoid Valve	Electronic Pressure Regulator Solenoids (EPRS)					
		1	2	3	4	5	6
P					ON	-ON-	
R				ON		ON	-ON-
N						ON	-ON-
D 1			ON			ON	-ON-
D 2			ON		ON		-ON-
D 3			ON	ON			-ON-
D 4		ON				ON	-ON-
D 5		ON			ON		-ON-
D 6		ON				ON	-ON-

ON = Active (pressure build up)
OFF = Inactive
-ON- = Inactive (pressure drain)

The following table shows which clutches are operating for selected gear ratios to produce the required torque output from the transmission.

Gear Selector Lever Position	Shift Control Solenoid Valve	Clutch				Brake	
		A	B	E	WK	C	D
P							X
R			X				X
N							X
D 1		X		X			X
D 2		X		X		X	
D 3		X	X	X			
D 4	ON	X		X	X		
D 5	ON		X	X	X		
D 6	ON			X	X	X	

X = clutch applied
Shift Elements

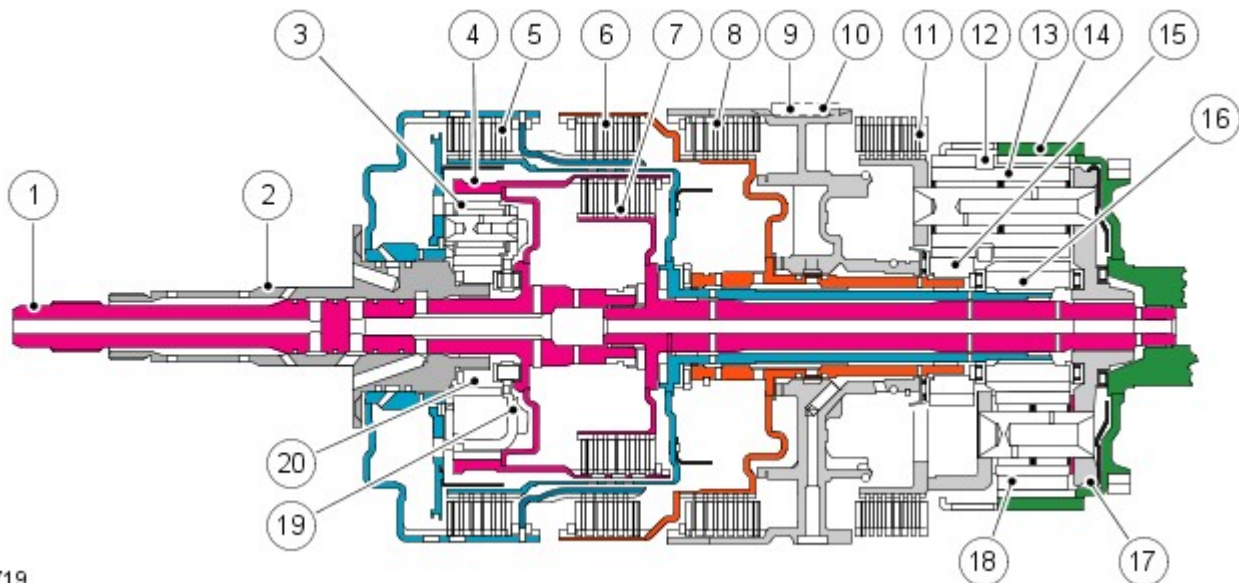

E42719

Item	Part Number	Description
1	-	Turbine shaft

2	-	Stator shaft
3	-	Single web planetary gear train
4	-	Ring gear 1
5	-	Clutch A
6	-	Clutch B
7	-	Clutch E
8	-	Brake clutch C
9	-	Fixed connection to transmission housing
10	-	Shaft key
11	-	Brake clutch D
12	-	Double web planetary gear train
13	-	Planetary gears - Long
14	-	Ring gear 2
15	-	Sunwheel 2
16	-	Sunwheel 3
17	-	Double web planetary gear carrier
18	-	Planetary gears - short
19	-	Single web planetary gear carrier
20	-	Sunwheel 1

The shift elements are three rotating multiplate clutches (A, B and E) and two fixed multiplate brakes (C and D). All shifts from 1st to 6th gears are power-on overlapping shifts. Overlapping shifts can be described as one of the clutches continuing to transmit drive at a lower main pressure until the next required clutch is able to accept the input torque.

The shift elements, clutches and brakes are actuated hydraulically. Fluid pressure is applied to the required clutch and/or brake, pressing the plates together and allowing drive to be transmitted through the plates. The purpose of the shift elements is to perform power-on shifts with no interruption to traction and smooth transition between gear ratios.

Power Flow 1st Gear

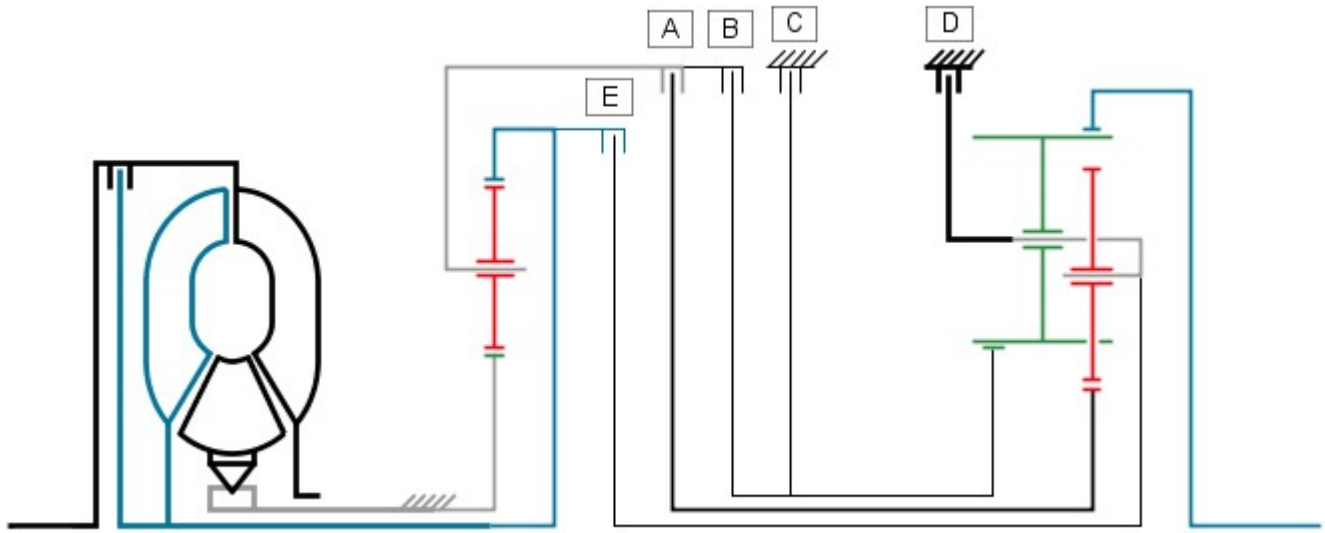

E42720

The gear selector lever and the manual selector valve spool are in the 'D' position. Engine torque is transmitted from the torque converter turbine shaft to the ring gear 1 of the single web planetary gear train and the outer plate carrier of clutch 'E'.

Ring gear 1 drives the planetary gears which rotate around sunwheel 1. This drives the planetary gear carrier 1 and also the outer plate carrier of clutch 'A' and the inner plate carrier of clutch 'B'.

When clutch 'A' is engaged, sunwheel 3 in the double web planetary gear train is driven and meshes with the short planetary gears.

The double web planetary gear train is locked against the transmission housing by brake 'D'. This allows ring gear 2 (output shaft) to be driven in the same direction as the engine via the long planetary gears.

- NOTE: Refer to 'Shift Elements' illustration for key

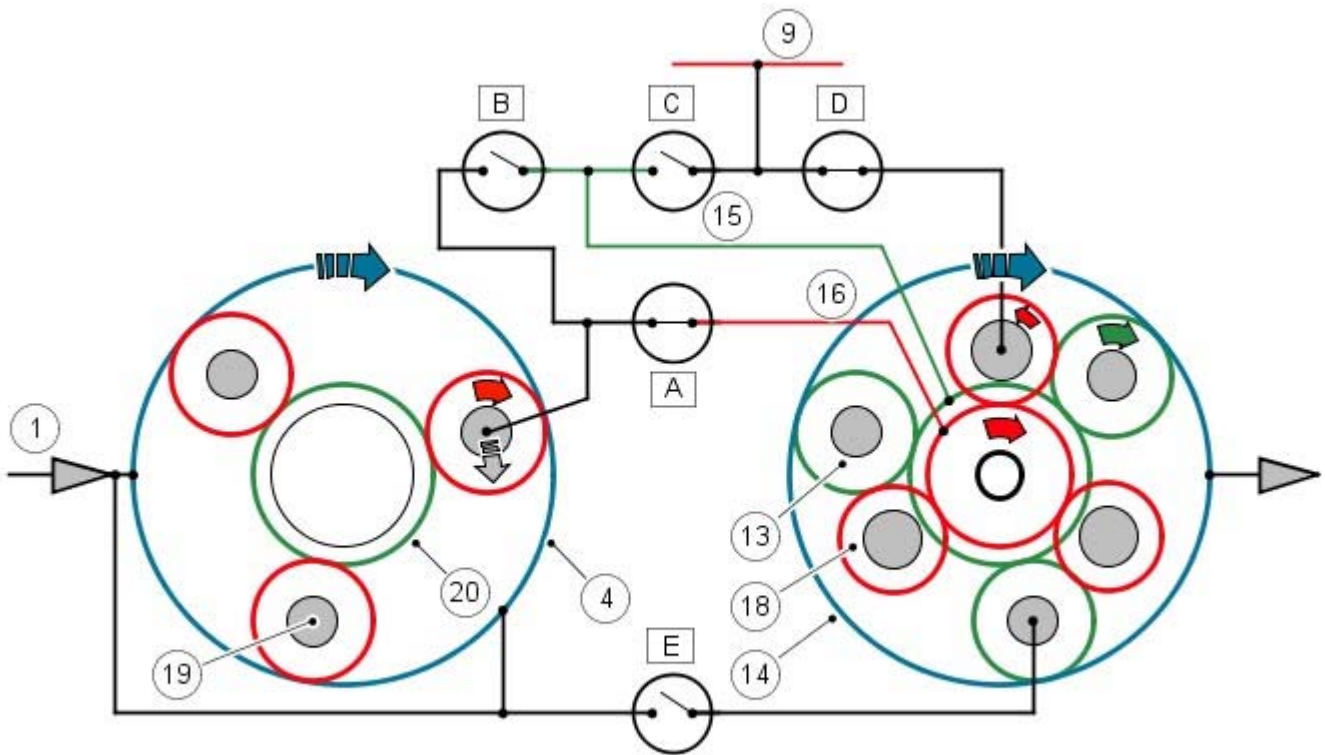

E42721

Power Flow 2nd Gear

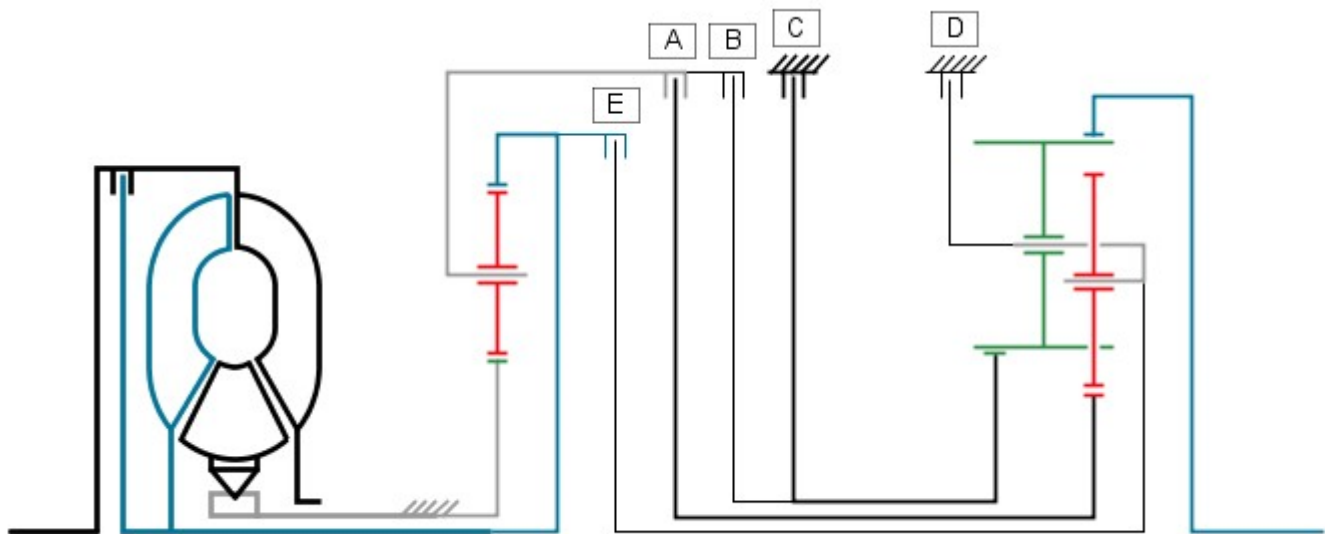

E42722

The gear selector lever and the manual selector spool valve are in the 'D' position. Engine torque is transmitted from the torque converter turbine shaft to the ring gear 1 of the single web planetary gear train and the outer plate carrier of clutch 'E'.

Ring gear 1 drives the planetary gears which rotate around sunwheel 1. This drives the planetary gear carrier 1 and also the outer plate carrier of clutch 'A' and the inner plate carrier of clutch 'B'.

When clutch 'A' is engaged, sunwheel 3 in the double web planetary gear train is driven and meshes with the short planetary gears.

Sunwheel 2 is locked to the transmission housing by brake clutch 'C'. The long planetary gears, which are also meshed with the short planetary gears, roll around the fixed sunwheel 2 and transmit drive to the double web planetary gear train carrier and ring gear 2 in the direction of engine rotation.

• NOTE: Refer to 'Shift Elements' illustration for key

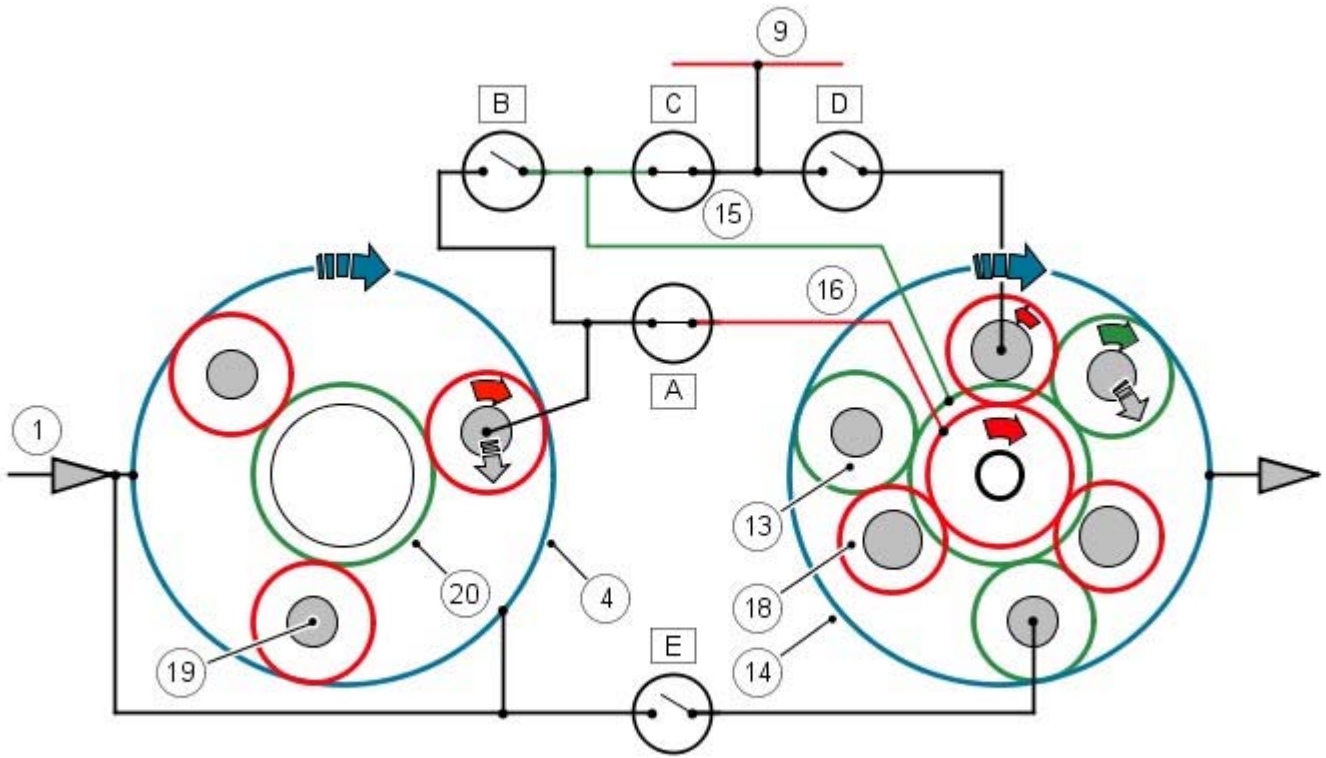

E42723

Power Flow 3rd Gear

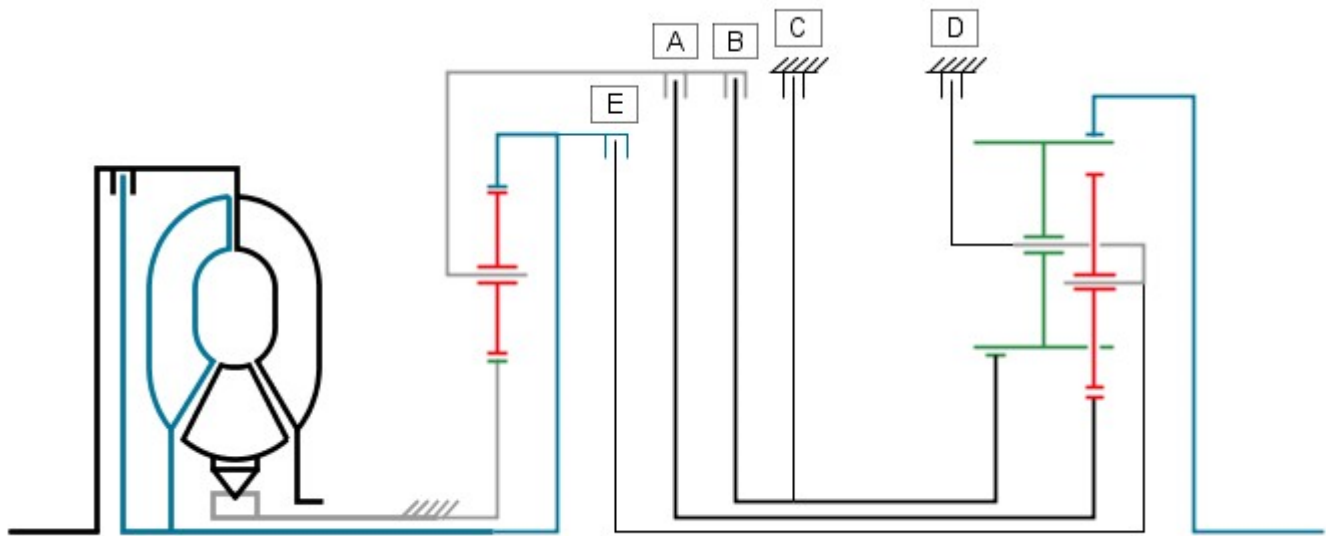

E 42724

The gear selector lever and the manual selector spool valve are in the 'D' position. Engine torque is transmitted from the torque converter turbine shaft to the ring gear 1 of the single web planetary gear train and the outer plate carrier of clutch 'E'.

Ring gear 1 drives the planetary gears which rotate around sunwheel 1. This drives the planetary gear carrier 1 and also the outer plate carrier of clutch 'A' and the inner plate carrier of clutch 'B'.

When clutch 'A' is engaged, sunwheel 3 in the double web planetary gear train is driven and meshes with the short planetary gears.

Sunwheel 2 is driven via clutch 'B' which is engaged. The long planetary gears, which are also meshed with the short planetary gears, cannot roll around the fixed sunwheel 2 and transmit drive to the locked double web planetary gear train carrier in the direction of engine rotation.

• NOTE: Refer to 'Shift Elements' illustration for key

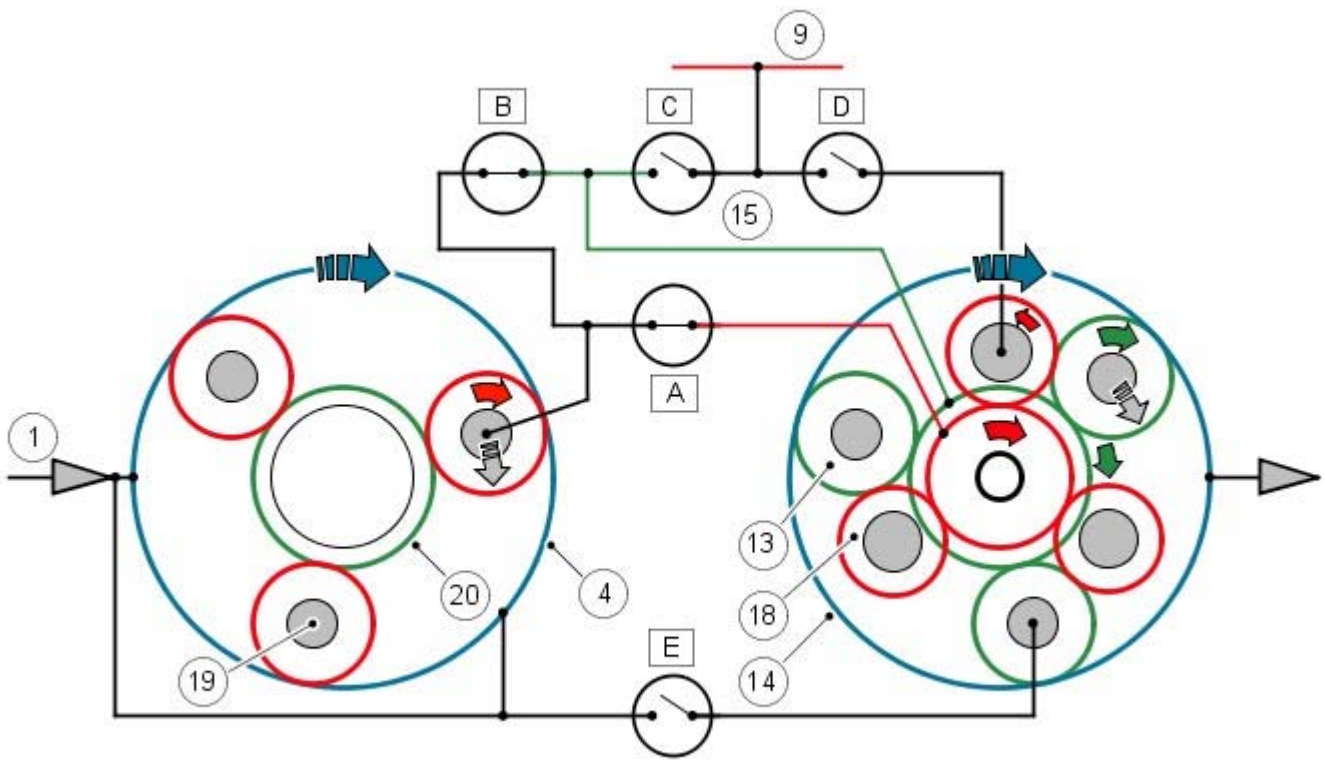

E42725

Power Flow 4th Gear

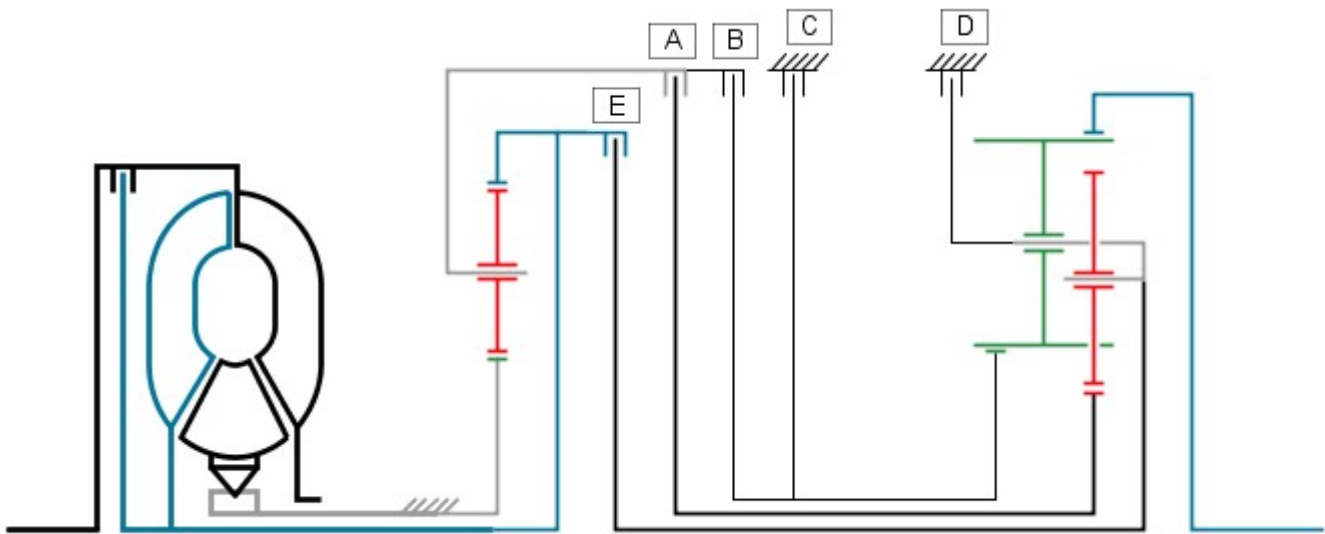

E42726

The gear selector lever and the manual selector spool valve are in the 'D' position. Engine torque is transmitted from the torque converter turbine shaft to ring gear 1 of the single web planetary gear train and the outer plate carrier of clutch 'E'.

Ring gear 1 drives the planetary gears which rotate around sunwheel 1. This drives the planetary gear carrier 1 and also the outer plate carrier of clutch 'A' and the inner plate carrier of clutch 'B'.

When clutch 'A' is engaged, sunwheel 3 in the double web planetary gear train is driven and meshes with the short planetary gears.

The double web planetary gear carrier is driven via clutch 'E' which is engaged. The long planetary gears, which are also meshed with the short planetary gears, and the double web planetary gear carrier, drive ring gear 2 in the direction of engine rotation.

• NOTE: Refer to 'Shift Elements' illustration for key

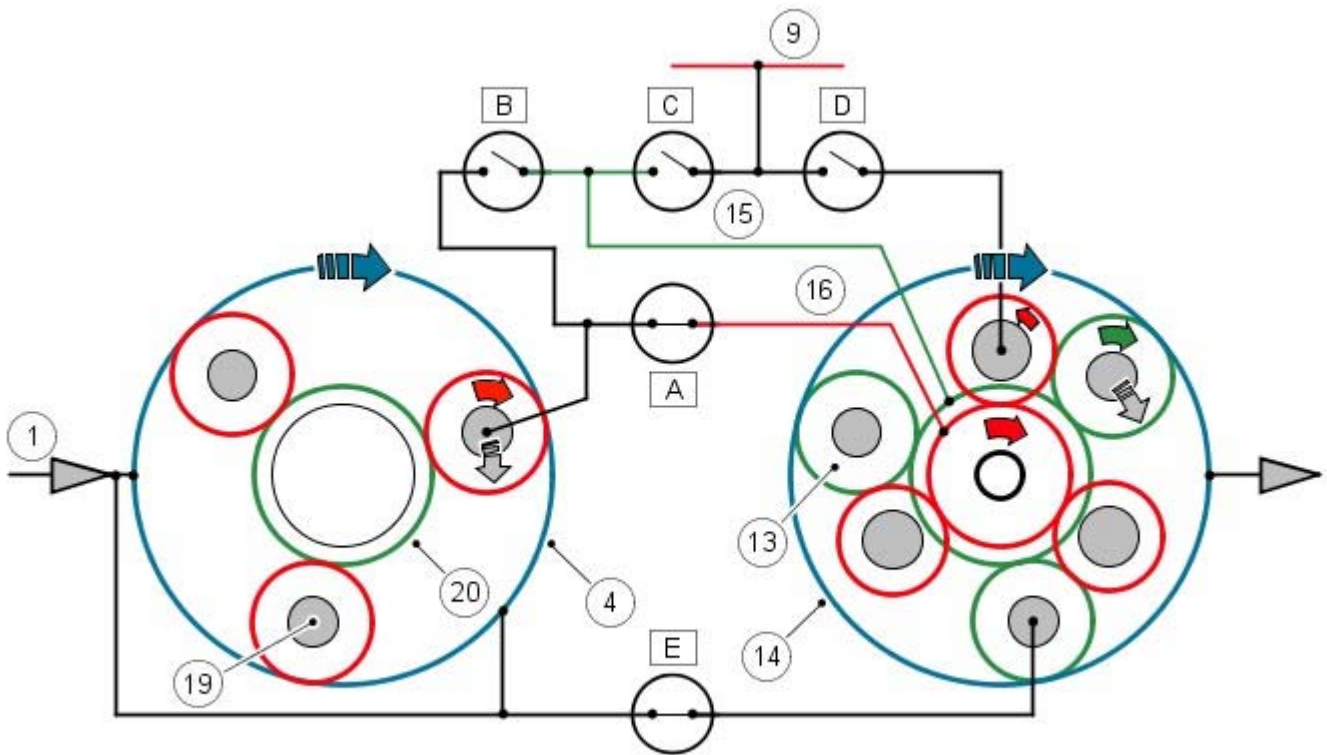

E42727

Power Flow 5th Gear

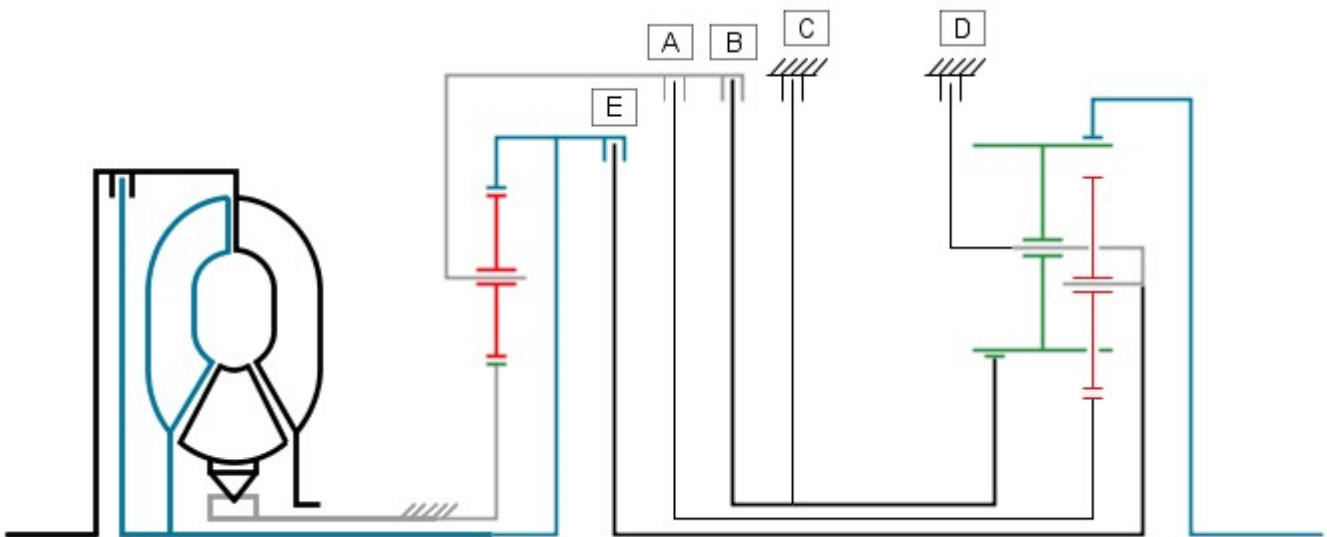

E42728

The gear selector lever and the manual selector spool valve are in the 'D' position. Engine torque is transmitted from the torque converter turbine shaft to ring gear 1 of the single web planetary gear train and the outer plate carrier of clutch 'E'.

Ring gear 1 drives the planetary gears which rotate around sunwheel 1. This drives the planetary gear carrier 1 and also the outer plate carrier of clutch 'A' and the inner plate carrier of clutch 'B'.

When clutch 'A' is engaged, sunwheel 3 in the double web planetary gear train is driven and meshes with the short planetary gears.

The long planetary gears, which are also meshed with the short planetary gears, and the double web planetary gear carrier, drive ring gear 2 in the direction of engine rotation.

• NOTE: Refer to 'Shift Elements' illustration for key

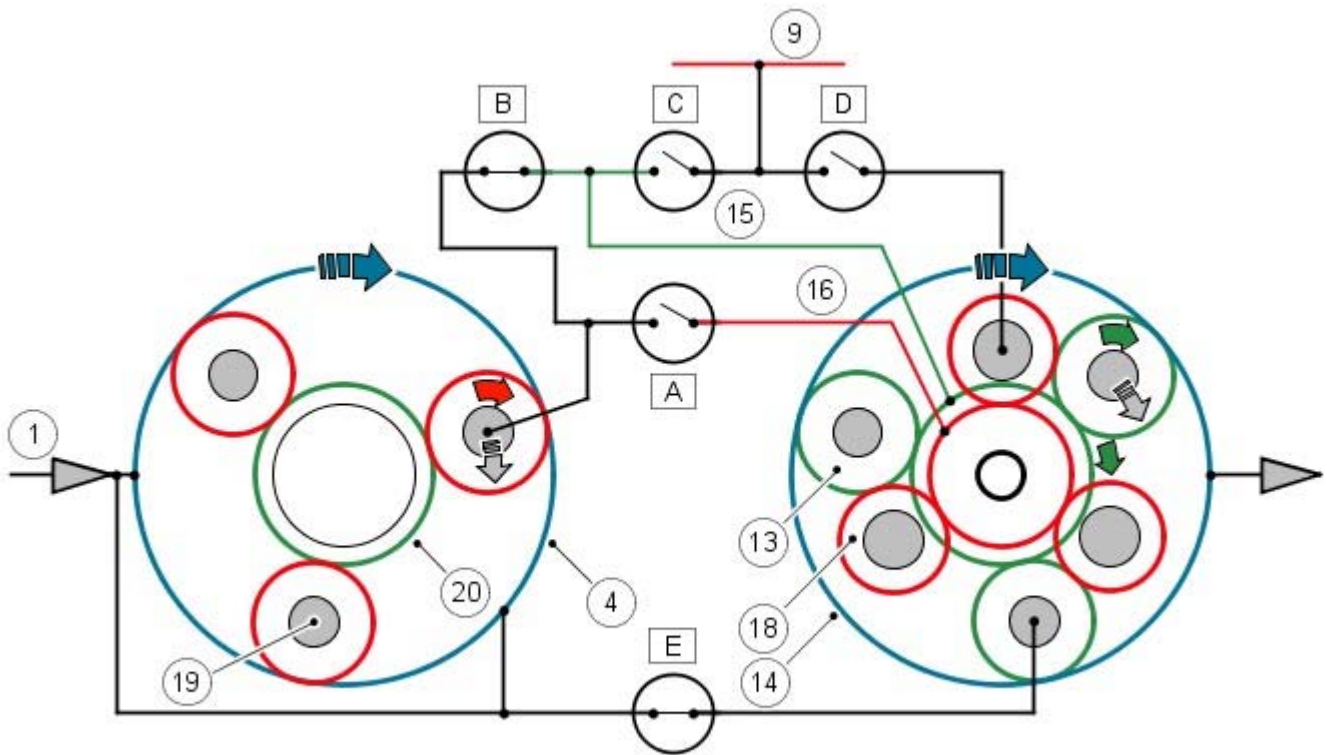

E42729

Power Flow 6th Gear

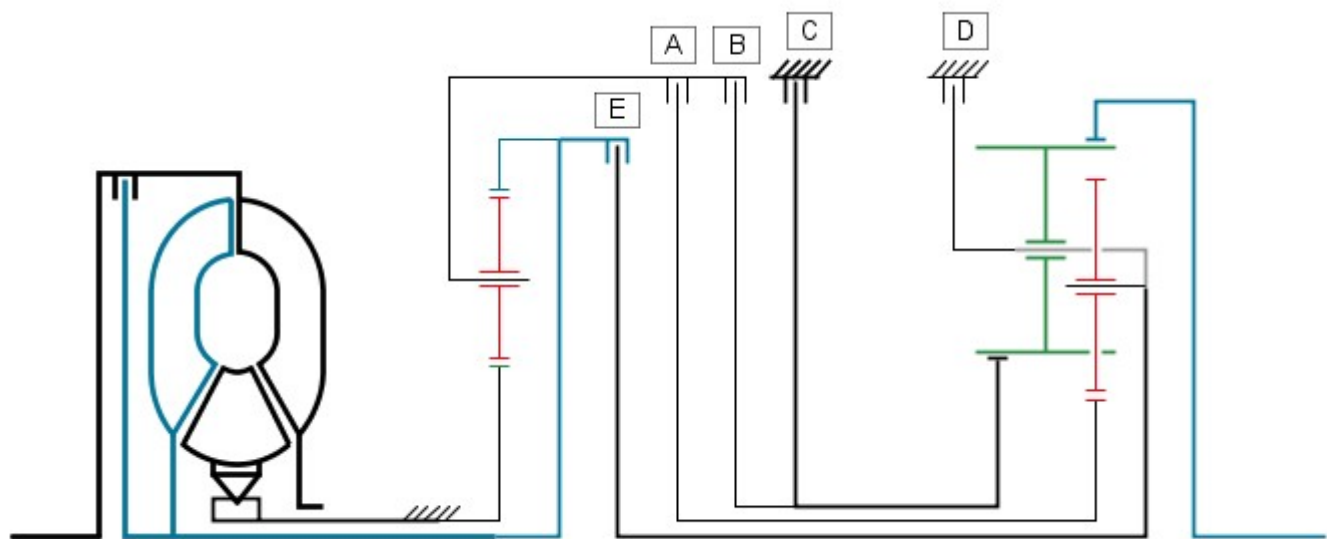

E42730

The gear selector lever and the manual selector spool valve are in the 'D' position. Engine torque is transmitted from the torque converter turbine shaft to ring gear 1 of the single web planetary gear train and the outer plate carrier of clutch 'E'.

Clutches 'A' and 'B' are released, removing the effect of the single web planetary gear train.

Clutch brake 'C' is applied which locks sunwheel 2 to the transmission housing.

Clutch 'E' is engaged and drives the double web planetary gear carrier. This causes the long planetary gears to rotate around the fixed sunwheel 2 and transmit drive to ring gear 2 which is driven in the direction of engine rotation.

- NOTE: Refer to 'Shift Elements' illustration for key

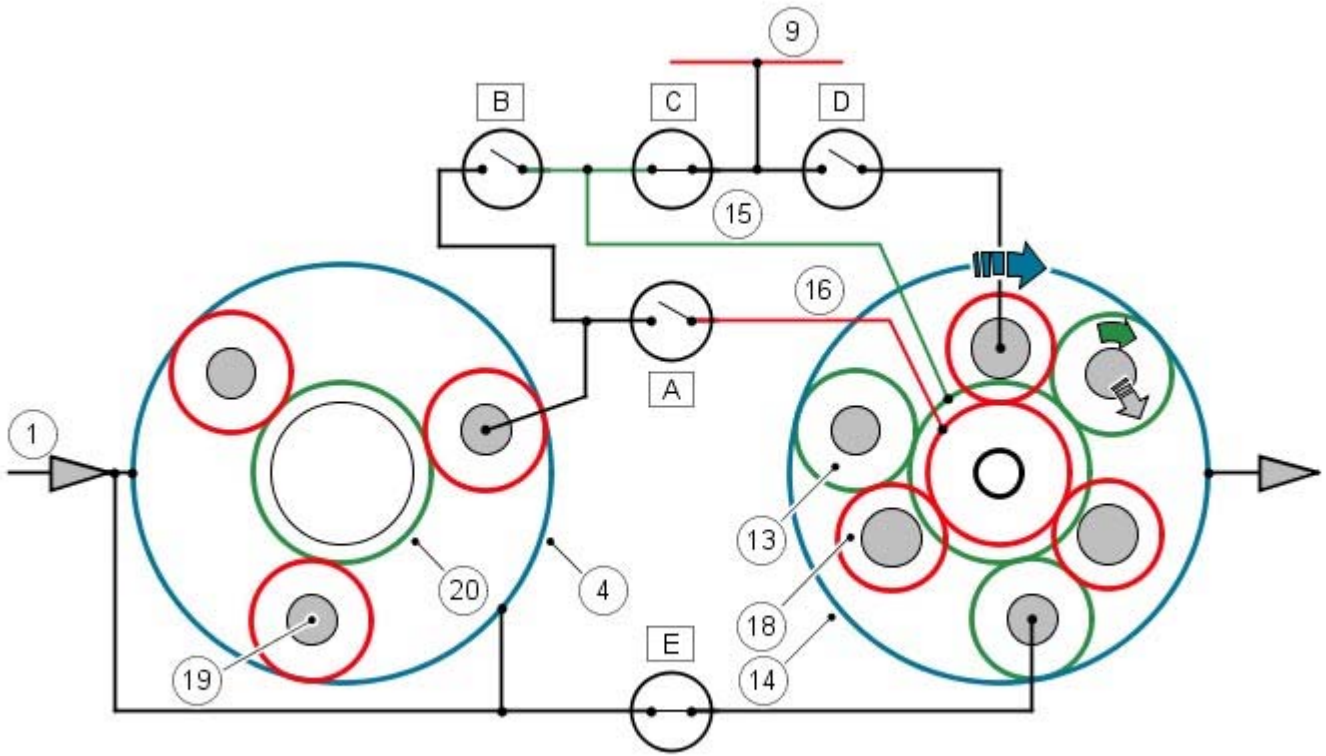

E42731

Power Flow Reverse Gear

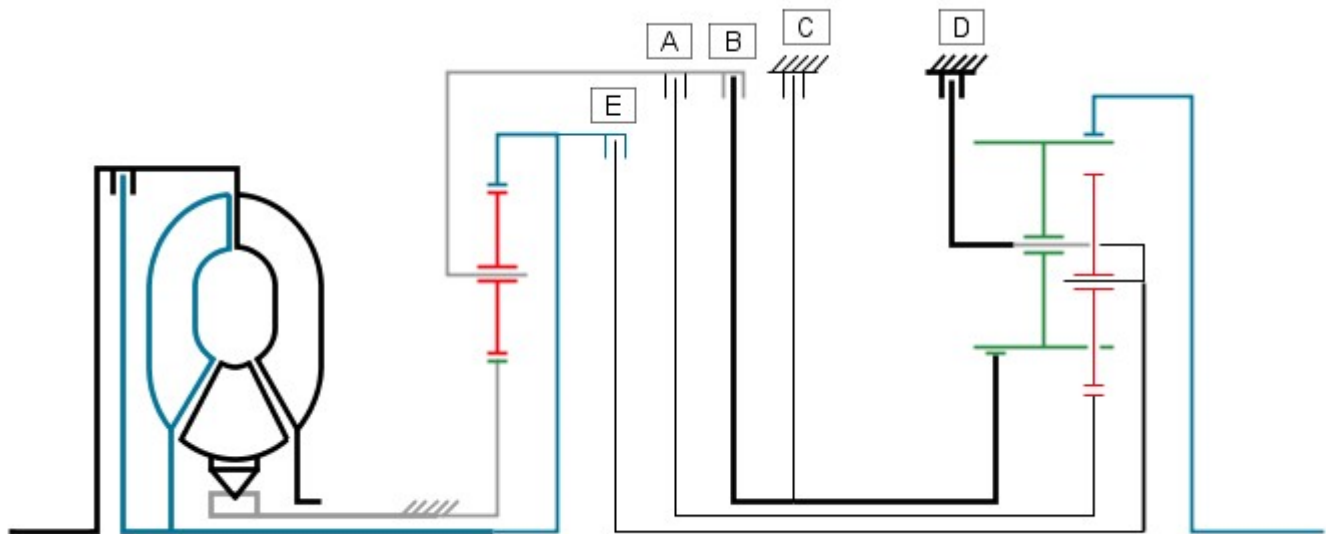

E42732

The gear selector lever and the manual selector spool valve are in the 'R' position. Engine torque is transmitted from the torque converter turbine shaft to ring gear 1 of the single web planetary gear train and the outer plate carrier of clutch 'E'.

Ring gear 1 drives the planetary gears of the single web planetary gear train which rotate around the fixed sunwheel 1. This transmits the drive to the single web planetary gear carrier, the outer plate carrier of clutch 'A' and the inner plate carrier of clutch 'B'.

With clutch 'B' applied, sunwheel 2 in the double web planetary gear train is driven and meshes with the long planetary gears.

The double web planetary gear carrier is locked to the transmission housing by brake clutch 'D'. This allows ring gear 2 to be driven in the opposite direction to engine rotation by the long planetary gears.

• NOTE: Refer to 'Shift Elements' illustration for key

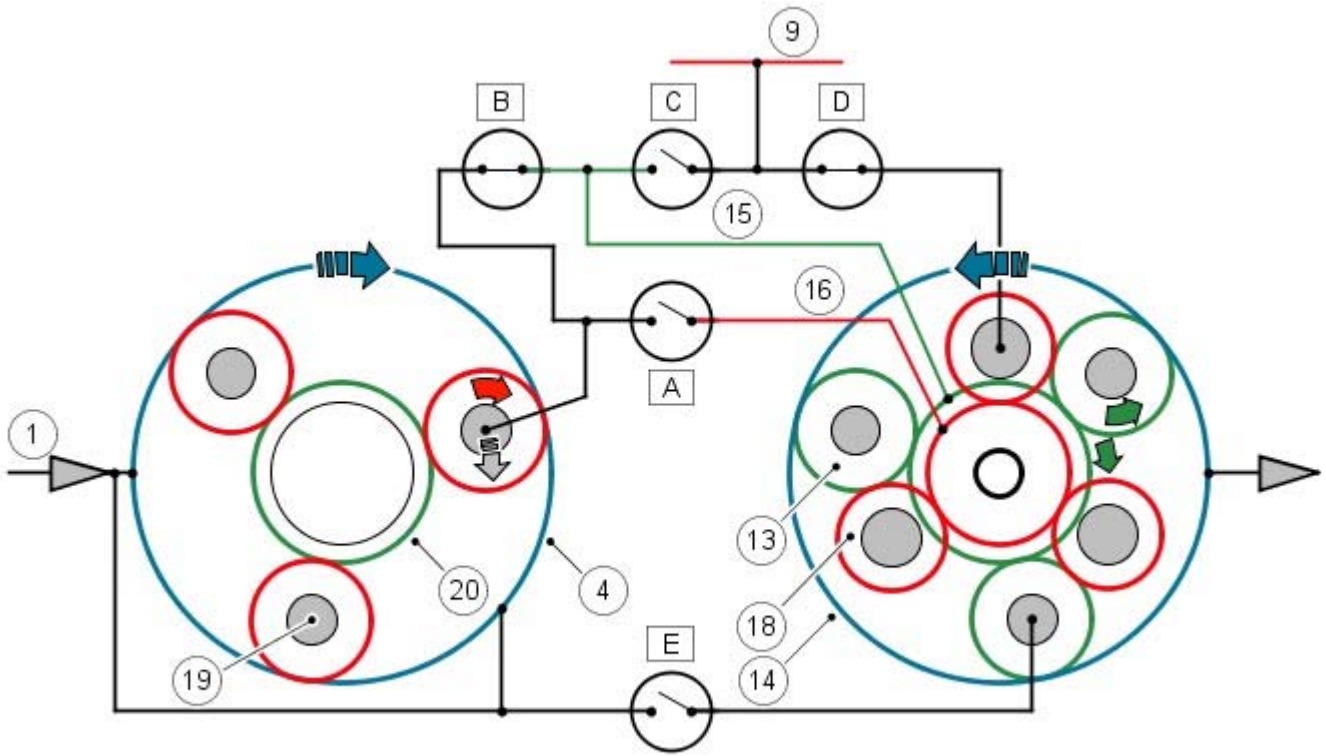

E42733

SELECTOR POSITION SWITCH

The Mechatronic valve block contains a position switch which is mechanically connected to the selector spool valve. The selector spool valve is connected by a selector shaft to the selector lever via a 'Bowden' selector cable.

The signals from the position switch are used by the TCM to determine the P, R, N or D selection made by the driver.

FLUID COOLING

The transmission fluid cooler is an integral part of the engine cooling radiator. The transmission is connected to the fluid cooler via flexible hoses and metal pipes.

- NOTE: 4.0L V6 Petrol shown, 4.4L V8 and TdV6 similar

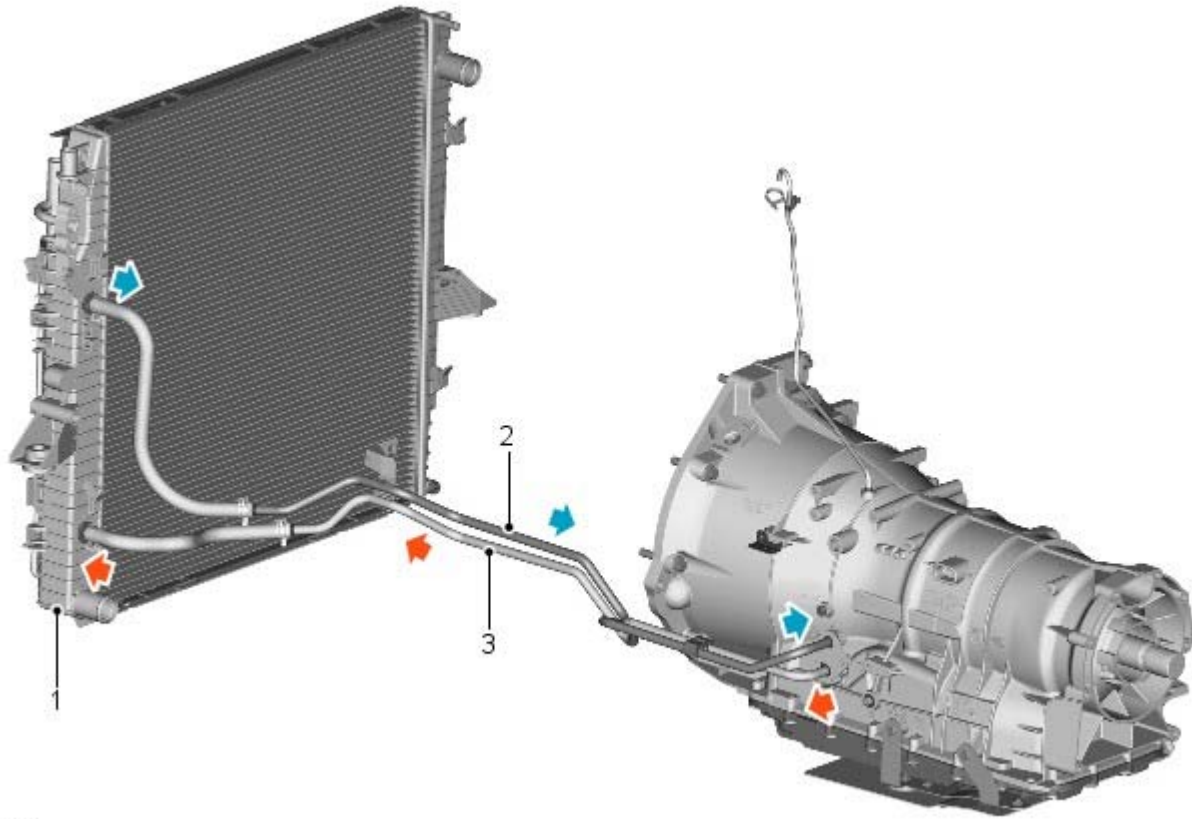

E42898

Item	Part Number	Description
1	-	Transmission cooler
2	-	Return pipe (To transmission)
3	-	Feed pipe (From transmission)

The transmission cooler is integrated into the left hand end tank of the engine cooling radiator. The transmission fluid is cooled by the temperature differential between the transmission fluid and the engine coolant and also by airflow over cooling fins on the end tank.

Fluid is supplied from the transmission fluid pump into the lower connection of the cooler. After passing through the cooler, the fluid passes out of the upper connection, and is returned to transmission fluid pan.

GEAR SELECTOR LEVER ASSEMBLY

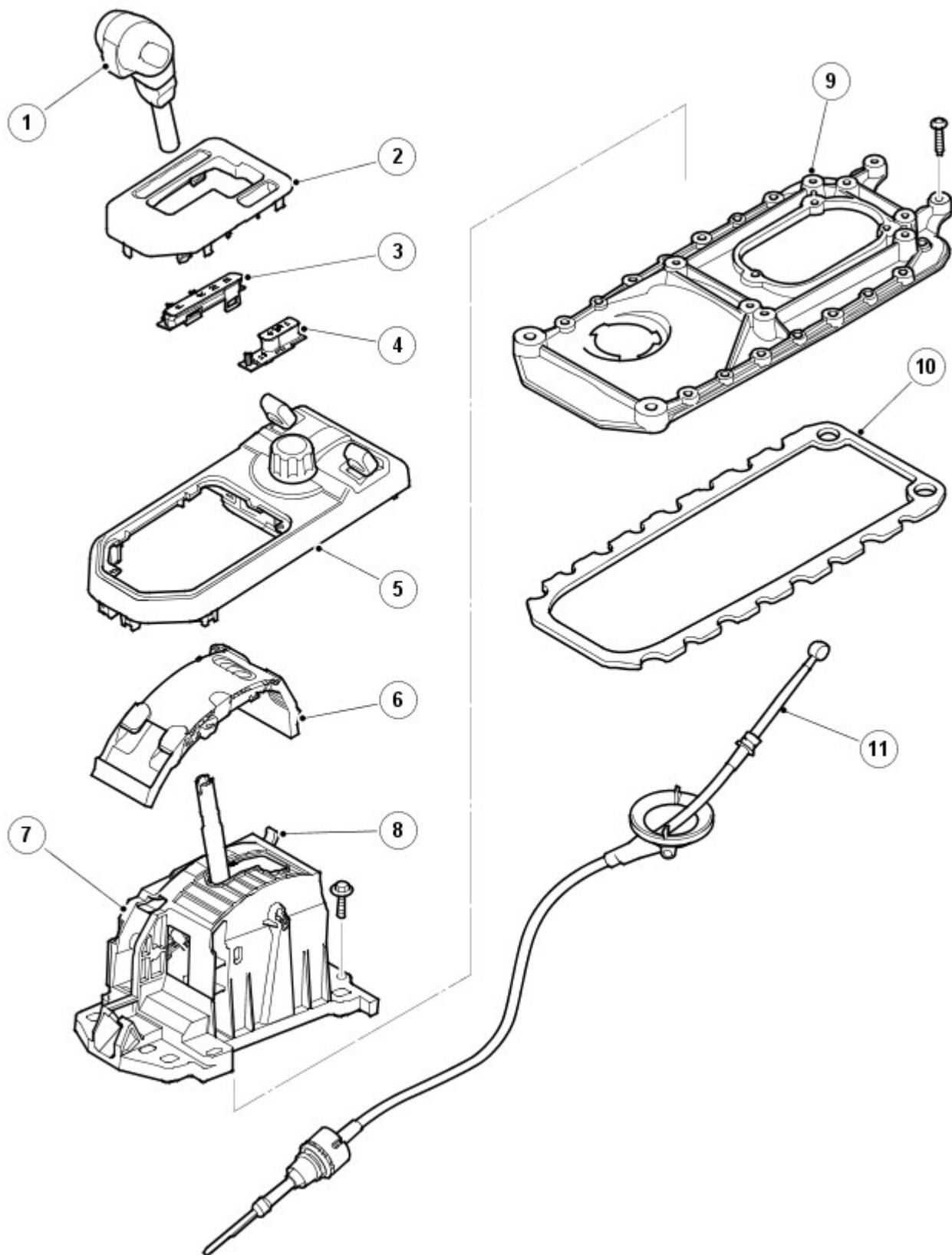

E42734

Item	Part Number	Description
1	-	Selector lever
2	-	Finisher
3	-	PRND display
4	-	M/S display
5	-	Switch pack and finisher
6	-	Shutter
7	-	Selector assembly
8	-	Interlock emergency release lever
9	-	Mounting plate
10	-	Seal

11	-	Selector cable
----	---	----------------

The gear selector lever assembly is located in a central position on the transmission tunnel, between the front driver and passenger seats and is secured to the transmission tunnel closure plate. The selector lever comprises a moulded plastic housing which provides for the location of the selector components.

The lever is connected to a crosspiece which allows for the selection of P, R, N, D in a forward or backward direction and selection between automatic and manual/sport mode in a left/right transverse direction.

When manual/sport mode is selected the lever can be moved in a forward or backward direction to select + or - for manual (CommandShift™) operation. If left in Sport mode all gear changes are performed automatically.

If Manual (CommandShift™) mode is selected, all gear changes are based on inputs received by the TCM from the manual +/- hall effect sensors located on the PCB.

The selector lever mechanism houses the following components:

- Electronic Printed Circuit Board (PCB)
- Shift Interlock solenoid
- Park and Neutral locking levers.

There are four selector lever positions and two additional positions for manual/sport operation:

- P (Park) - Prevents the vehicle from moving by locking the transmission
- R (Reverse) - Select only when the vehicle is stationary and the engine is at idle
- N (Neutral) - No torque transmitted to drive wheels
- D (Drive) - This position uses all six forward gears in high and low ranges
- M/S (Sport Mode) - This position uses all forward gears in 'D' but will upshift at higher engine speeds to improve acceleration
- + and - (Manual 'CommandShift™' mode) - Movement of the selector lever in the +/- positions, when the lever is in the M/S position, will operate the transmission in manual (CommandShift™) mode allowing the driver to manually select all six forward gears

The selector lever position is displayed to the driver on the selector position LED display and in the instrument cluster. In 'CommandShift™' mode, if a gear is selected but the TCM logic prevents selection of that gear, the requested gear will be initially displayed. The TCM will engage the next allowed gear and then display that gear.

Sport/Manual +/- CommandShift™ Switch

The PCB contains the hall effect sensors to activate the sport/manual mode and also the sensors which provide the +/- signals. When the selector lever is moved to the manual/sport position, the lower magnet located in the selector lever is moved within proximity of the M/S hall effect sensor on the PCB. This provides the momentary signal which is received by the TCM, which in turn initiates sport mode.

When the lever is moved to the + or - position, the magnet is moved within proximity of one of the hall effect sensors positioned either side of the M/S hall effect sensor. When an input from either the + or - sensors is received, manual CommandShift™ mode will be initiated. In this position a spring will move the selector lever back to the centre position when released. To leave the CommandShift™ mode, return the lever to the 'D' position.

Selector Position LED Display

The P, R, N, D LED display is located on the right hand side of the selector lever and the M/S (MANUAL/SPORT) +/- LED display is located on the left hand side of the selector lever. Each LED display is connected via a separate harness to the selector lever position switch. When the lever is moved to the required position, the switch contact for that position is made and the LED is illuminated.

P, R, N, D Position Switch

The P, R, N, D position switch is located within the Mechatronic valve block in the transmission. The switch is operated by movement of the selector lever to the P, R, N or D positions via the Bowden cable which is connected between the selector lever and the transmission selector shaft.

The switch is electrically connected to the TCM which outputs a common power supply to each of the four switch contacts. This power supply is also used by the two speed sensors and the fluid temperature sensor. Each of the four switch contacts have a separate feed input to the TCM which can detect which selector lever position has been selected.

Shift Interlock Solenoid

The shift interlock solenoid is located on the side of the selector lever assembly. The solenoid operates two locking levers which engage in the lower lever and lock it in the Park (P) and Neutral (N) positions. When the ignition is on or the engine is running, the solenoid is de-energised and prevents the lever from moving.

When energised, by the depression of the footbrake, the solenoid is energised and the selector lever may be moved from the P position. If the selector lever is left in the N position for more than 800m/s the solenoid will be energised and the selector lever will become locked in the N position. To move the selector lever from the N position in this condition the footbrake must be applied. This prevents the selector lever from being moved to the 'D' or 'R' position unintentionally and the application of the brakes also prevents the vehicle 'creeping' when the gear is engaged.

Movement of the selector lever from the 'P' or 'N' positions is also prevented if the TCM senses the engine speed is above 2500 rev/min, even if the brake pedal is depressed.

In the event of an electrical failure of the vehicle or failure of the interlock solenoid or its associated wiring, it is possible to move the selector lever from the Park 'P' position by removing the coin tray on left hand drive vehicles or the trim panel behind the park brake switch on right hand drive vehicles and lifting the white coloured tab on the rear of the selector lever assembly. Whilst holding the tab in this position move the selector lever from the 'P' position.

The selector lever will also be locked in the N position during the transfer box changing range from high to low or vice

versa.

Selector Cable

A selector cable is used as a mechanical connection between the selector lever and the transmission. The cable is a Bowden type cable which is connected to the selector lever. Movement of the lever in the P, R, N or D positions moves the cable. Movement of the cable is prevented when the selector lever is in the Manual/Sport position.

The cable is passed through a sealing grommet in the floorpan and is attached to a bracket on the transmission. The inner cable is connected to a lever which is positively attached to the transmission selector shaft.

Movement of the selector lever in the P, R, N or D positions moves the inner cable which in turn moves the lever. The lever transforms the linear movement of the cable into rotary movement of the selector shaft. The rotation of the shaft moves the position switch located within the Mechatronic valve block and also moves the manual spool valve to the applicable position.

Inputs and Outputs

Connector C2658

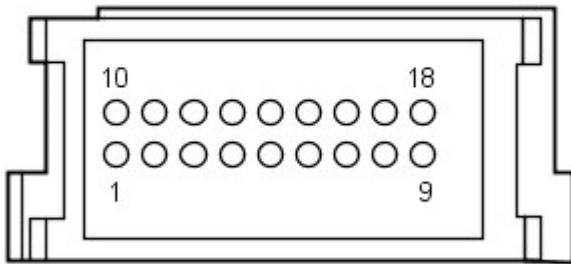

E42931

The following table shows the connector pin details for the connector on the selector lever assembly.

Pin No.	Description	Input/Output
1	Ground	-
2	Park lock confirmation	Input
3	Ground	-
4	Sport/Manual switch	Output
5	CommandShift™ + (up shift)	Output
6	CommandShift™ - (down shift)	Output
7	Ignition position II supply 12V	Input
8	Permanent power supply 12V	Input
9	Shift Interlock solenoid +	Input
10	Shift Interlock solenoid -	Input
11	Selector indicator PARK LED	Output
12	Selector indicator REVERSE LED	Output
13	Selector indicator NEUTRAL LED	Output
14	Selector indicator DRIVE LED	Output
15	Selector indicator SPORT/MANUAL LED	Output
16	Selector indicator backlight	Output - PWM
17 - 18	Not used	-

INSTRUMENT CLUSTER

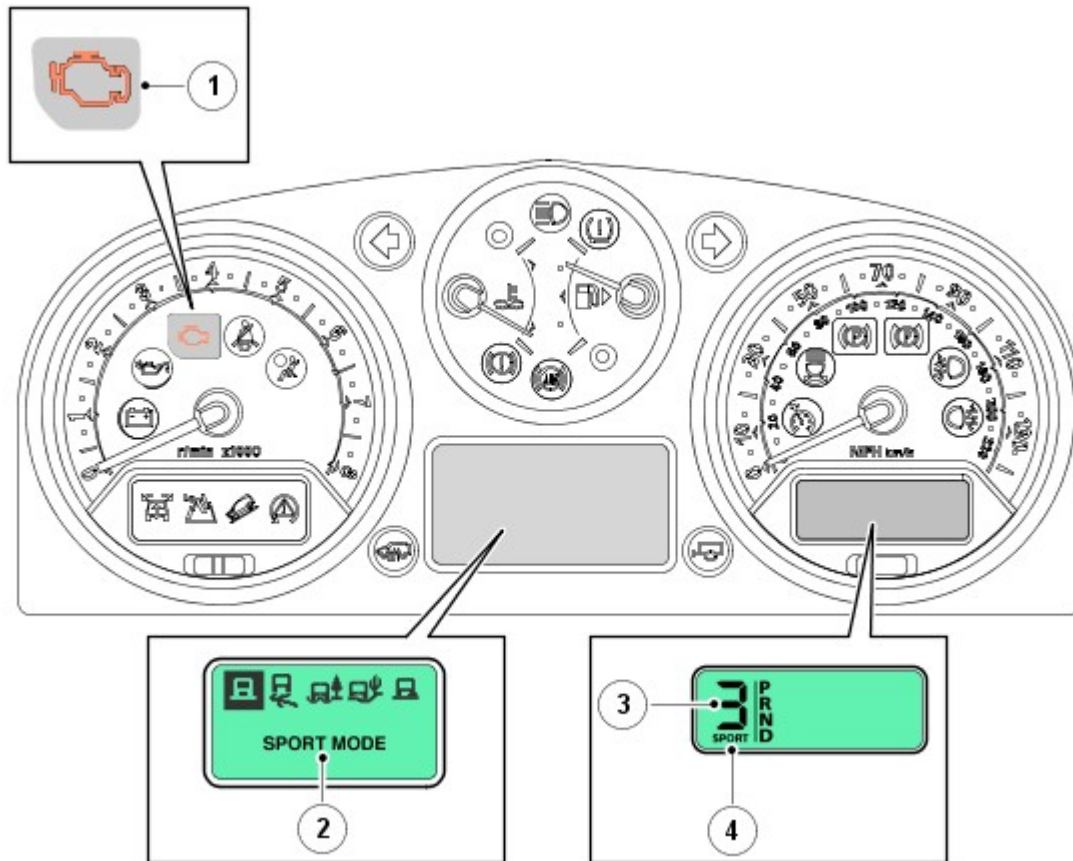

E42905

Item	Part Number	Description
1	-	Malfunction Indicator Lamp (MIL)
2	-	Message centre
3	-	Selector lever position indicator
4	-	Mode display

The instrument cluster is connected to the TCM via the high speed CAN bus. Transmission status is transmitted by the TCM and displayed to the driver in one of two displays in the instrument cluster.

For additional information, refer to: Instrument Cluster (413-01, Description and Operation).

Malfunction Indicator Lamp (MIL)

The MIL is located in the tachometer in the instrument cluster. Transmission related faults which may affect the vehicle emissions output will illuminate the MIL.

The MIL is illuminated by the ECM on receipt of a relevant fault message from the TCM on the high speed CAN. The nature of the fault can be diagnosed using T4 which reads the fault codes stored in the TCM memory.

Transmission Status Display

The transmission status display is located in a Liquid Crystal Display (LCD) within the speedometer housing. The LCD shows the selector lever position and the selected transmission mode. When the selector lever is in the manual CommandShift™ position, the selector lever position display will show the selected gear ratio.

The following table shows the displays and their descriptions.

Symbol	Description
P	Park selected
R	Reverse selected
N	Neutral selected
D	Drive selected
1	1st gear selected (Manual CommandShift™ mode)
2	2nd gear selected (Manual CommandShift™ mode)
3	3rd gear selected (Manual CommandShift™ mode)
4	4th gear selected (Manual CommandShift™ mode)
5	5th gear selected (Manual CommandShift™ mode)
6	6th gear selected (Manual CommandShift™ mode)

Message Centre Display

The message centre is located in the lower centre of the instrument cluster. The message centre is a LCD to relay vehicle status and operating information to the driver. The message centre can display messages relating to a number of the vehicle systems. The following list shows the possible transmission related messages:

- TRANSMISSION FAULT LIMITED GEARS AVAILABLE
- TRANSMISSION FAULT AND OVERHEAT
- TRANSMISSION FAULT

- TRANSMISSION OVERHEAT

TRANSMISSION CONTROL MODULE (TCM)

The TCM is an integral part of the Mechatronic valve block which is located at the bottom of the transmission, behind the fluid pan. The TCM is the main controlling component of the transmission.

The TCM processes signals from the transmission speed and temperature sensors, engine control module and other vehicle systems. From the received signal inputs and pre-programmed data, the module calculates the correct gear, torque converter clutch setting and optimum pressure settings for gear shift and lock-up clutch control.

The TCM outputs signals to control the shift control solenoid valve and the Electronic Pressure Regulator Solenoids (EPRS) to control the hydraulic operation of the transmission.

The ECM supplies the engine management data on the high speed CAN bus system. The TCM requires engine data to efficiently control the transmission operation, for example; flywheel torque, engine speed, accelerator pedal angle, engine temperature etc.

The steering angle sensor and the ABS module also supply data to the TCM on the high speed CAN bus system. The TCM uses data from these systems to suspend gear changes when the vehicle is cornering and/or the ABS module is controlling braking or traction control.

The selector lever is connected to the automatic transmission and the position switch in the transmission by a Bowden cable. Movement of the selector lever moves the position switch via the Bowden cable and the switch position informs the TCM of the selected position. The sport/manual +/- CommandShift switch passes manual/sport selections to the TCM. An additional switch provides a selector lever in park position signal. Once the selector lever position is confirmed, the TCM outputs appropriate information which is received by the instrument cluster to display the gear selection information in the message centre.

The Mechatronic valve block also contains the speed and temperature sensors. These are integral with the Mechatronic valve block and cannot be serviced individually. The speed sensors measure the transmission input and output speeds and pass signals to the TCM. The fluid temperature sensor is also located in the valve block and measures the fluid temperature of the transmission fluid in the fluid pan.

The TCM is connected to the starter relay coil. When the selector lever is in PARK or NEUTRAL, the module provides a ground for the coil allowing the starter relay to be energised and allow starter motor operation. If the selector lever is in any other position, the module will not provide the ground preventing starter motor operation.

Inputs and Outputs

Connector C0193



E42922

The following table shows the connector pin details for the connector on the transmission.

Pin No.	Description	Input/Output
1	Manual/sport shift programme selection	Input
2	CAN low	Input/Output
3	Diagnostic ISO9141 K Line bus	Input/Output
4	CommandShift™ - (downshift)	Input
5	CommandShift™ + (upshift)	Input
6	CAN high	Input/Output
7	Shiftlock power supply	Output
8	Not used	-
9	Ignition position II supply 12V	Input
10	Park/Neutral signal (starter inhibit)	Input
11	Shiftlock ground	Output
12	Selector lever in park position confirmation signal	Input
13	Ground 1	-
14	Permanent power supply 12V	Input
15	Not used	-
16	Ground 2	-

DIAGNOSTICS

The diagnostic socket is located in the lower instrument panel closing panel, on the driver's side, below the steering

column.

The diagnostic socket allows the exchange of information between the various modules on the bus systems and T4 or a diagnostic tool using ISO14229 protocol. The information is communicated to the socket via the high speed CAN bus from the TCM. This allows the retrieval of diagnostic information and programming of certain functions using T4 or a suitable diagnostic tool.

The TCM uses a P code strategy which stores industry standard Diagnostic Trouble Codes (DTC) relating to faults.

P Code	Component/Signal	Fault Description
P012100	Kickdown	Signal not plausible
P021900	Stall speed/engine overspeed	Signal not plausible
P050000	Wheel speeds plausible signal	General fault type
P050100	Wheels speeds plausible signal	Signal not plausible
P056100	Power supply (battery)	General fault type
P056200	Power supply (battery)	Signal voltage too low
P056300	Power supply (battery)	Signal voltage too high
P060100	EPROM/FLASH Checksum	Signal not plausible
P060300	Battery buffered RAM	Signal not plausible
P060500	EPROM/FLASH Checksum after software verification	Signal not plausible
P061300	Watchdog locking mechanism	General fault type Signal not plausible Short circuit to power supply Short circuit to ground Circuit break Short circuit to ground or power break Signal voltage too high Signal voltage too low Function specific, see monitoring function
P061300	Micro controller components	General fault type No change in signal Function specific, see monitoring function
P062F00	EEPROM communication	General fault type
P064100	Sensor supply voltage	Signal voltage too high or too low
P065700	Power supply pressure regulators and solenoids	Signal not plausible Circuit break
P065800	Power supply pressure regulators and solenoids	Short circuit to ground
P065900	Power supply pressure regulators and solenoids	Short circuit to power supply
P066800	Micro processor chip temperature sensor	Signal voltage too low
P066900	Micro processor chip temperature sensor	Signal voltage too high
P070000	Combination of impossible substitute functions	General fault type Signal not plausible Signal voltage too high
P070500	Selector position switch	Signal not plausible
P071000	Transmission oil temperature	Circuit break
P071100	Transmission oil temperature	General fault type Signal voltage too high
P071200	Transmission oil temperature	Short circuit to ground
P071300	Transmission oil temperature	Short circuit to power supply
P071600	Transmission turbine speed sensor	Short circuit to ground or power break Signal voltage too high Signal voltage too low
P071700	Transmission turbine speed sensor	Short circuit to power supply
P072000	Transmission output shaft speed sensor	Short circuit to power supply Short circuit to ground or power break
P072100	Transmission output shaft speed sensor	Signal voltage too high Signal not plausible
P072100	Falling gradient on output speed	Signal not plausible
P072900	Gear ratio - 6th gear	Signal not plausible
P073000	Gear ratio symptom	Signal not plausible
P073100	Gear ratio - 1st gear	Signal not plausible
P073200	Gear ratio - 2nd gear	Signal not plausible
P073300	Gear ratio - 3rd gear	Signal not plausible
P073400	Gear ratio - 4th gear	Signal not plausible
P073500	Gear ratio - 5th gear	Signal not plausible
P073600	Gear ratio - reverse gear	Signal not plausible General fault type
P074000	EPRS 6	Circuit break
P074100	Torque converter clutch permanently open	General fault type
P074800	EPRS 1	Signal voltage too high or too low
P075100	Shift control solenoid valve	Short circuit to power or ground Circuit break
P075200	Shift control solenoid valve	short circuit to ground
P075300	Shift control solenoid valve	Short circuit to power supply
P077800	EPRS 2	Signal voltage too high or too low
P078000	Gear load symptom	Signal voltage too high No change in signal

P Code	Component/Signal	Fault Description
P078100	Gear load during shift 1st to 2nd	Signal voltage too high No change in signal
P078100	Gear load during shift 2nd to 1st	Signal voltage too high No change in signal
P078200	Gear load during shift 2nd to 3rd	Signal voltage too high No change in signal
P078200	Gear load during shift 3rd to 2nd	Signal voltage too high No change in signal
P078300	Gear load during shift 3rd to 4th	Signal voltage too high No change in signal
P078300	Gear load during shift 4th to 3rd	Signal voltage too high No change in signal
P078400	Gear load during shift 4th to 5th	Signal voltage too high No change in signal
P078400	Gear load during shift 5th to 4th	Signal voltage too high No change in signal
P079800	EPRS 3	Signal voltage too high or too low
P081C00	Lever locking mechanism	General fault type Signal not plausible
P082600	Manual/Sport switch module	Signal not plausible
P082900	Gear load during shift 4th to 5th	Signal voltage too high
P082900	Gear load during shift 5th to 6th	No change in signal
P082900	Gear load during shift 6th to 5th	No change in signal
P085000	Park/Neutral signal plausibility	Signal not plausible
P089700	Oil temperature monitoring	General fault type
P093800	Transmission oil temperature (cross-check against processor chip temperature)	Signal not plausible
P096000	EPRS 1	Short circuit to ground or power break Circuit break
P096200	EPRS 1	Short circuit to ground
P096300	EPRS 1	Short circuit to power supply
P096400	EPRS 2	Short circuit to ground or power break Circuit break
P096600	EPRS 2	Short circuit to ground
P096700	EPRS 2	Short circuit to power supply
P096800	EPRS 3	Short circuit to ground or power break Circuit break
P097000	EPRS 3	Short circuit to ground
P097100	EPRS 3	Short circuit to power supply
P178300	Hot shutdown	General fault type
P182500	Shift interlock solenoid	Short circuit to ground Short circuit to power supply Circuit break
P271600	EPRS 4	Signal voltage too high or too low
P271800	EPRS 4	Short circuit to ground or power break Circuit break
P272000	EPRS 4	Short circuit to ground
P272100	EPRS 4	Short circuit to power supply
P272500	EPRS 5	Signal voltage too high or too low
P272700	EPRS 5	Short circuit to ground or power break Circuit break
P272900	EPRS 5	Short circuit to ground
P273000	EPRS 5	Short circuit to power supply
P275900	EPRS 6	Signal voltage too high
P276100	EPRS 6	Short circuit to ground or power break
P276200	EPRS 6	Signal voltage too small
P276300	EPRS 6	Short circuit to power supply
P276400	EPRS 6	Short circuit to ground

CONTROLLER AREA NETWORK (CAN)

The high speed CAN broadcast bus network is used to connect the powertrain modules. The CAN bus is connected between the following electronic units:

High Speed CAN Bus

- TCM
- Instrument cluster
- Air suspension module
- Steering angle sensor
- Rear differential module
- Centre console switch pack
- Electric park brake module
- Restraints control module
- Engine Control Module (ECM)
- ABS control module
- Adaptive front lighting control module
- Transfer box control module
- Adaptive cruise control module

- Diagnostic socket.

The CAN bus allows a fast exchange of data between modules. The CAN bus comprises two wires which are identified as CAN high (H) and CAN low (L). The two wires are coloured yellow/black (H) and yellow/brown (L) and are twisted together to minimise electromagnetic interference (noise) produced by the CAN bus messages. For additional information, refer to: Communications Network (418-00, Description and Operation).

In the event of CAN bus failure, the following symptoms may be observed:

- Transmission operates in default mode
- Torque converter lock-up clutch control is disabled
- Gear position indication in instrument cluster message centre inoperative (this will also occur with any transmission fault).

DRIVING MODES

There are a number of different driving modes of operation. Some can be selected by the driver and some are automatically initiated by the TCM during driving:

- Normal mode
- Sport mode
- Manual (CommandShift™) mode
- Adaptive Shift Strategy (ASIS)
- Hill Descent Control (HDC) mode
- Cruise mode
- Hill mode
- Default (Limp home) mode
- Reverse lock-out mode
- Cooling strategy.
- Curve recognition mode
- Fast off recognition

Normal Mode

Normal mode is automatically selected by the TCM on power up. In this mode all automatic and adaptive modes are active. Normal mode uses gear shift and lock-up maps to allow for vehicle operation which offers fuel consumption and emissions or driveability depending on the driving style. If the transmission is operated in sport or manual mode and the selector lever is moved to the 'D' position, normal mode is automatically resumed.

Sport Mode

The sport mode operates in high range only and provides enhanced acceleration and responsiveness. In sport mode the TCM uses shift maps which allow the transmission to downshift more readily, hold gears for longer at higher engine speeds, and limits the transmission to the first five gears (6th gear is not used).

Sport mode is selected by moving the selector lever to the left into the 'M/S' position. When the sport mode is first selected, 'SPORT' is displayed in the message centre for 6 seconds and, if 6th gear is currently engaged, the TCM downshifts to 5th.

Manual (CommandShift™) Mode

Manual mode allows the transmission to operate as a semi-automatic 'CommandShift™' unit. The driver can change up and down the six forward gears with the freedom of a manual transmission.

Shift maps are provided for manual mode to protect the engine at high engine speeds. The TCM will automatically change up to a higher gear ratio to prevent engine overspeed and change down to a lower gear ratio to avoid engine labouring and stalling.

When kickdown is requested the TCM downshifts at least 2 gears.

When the vehicle is stationary, to drive off the driver can select 1st, 2nd or 3rd gear in low and high range. Any other gear selection will be rejected by the TCM.

When driving off, upshifts can be pre-selected by making + selections with the selector lever for the number of upshifts required. The TCM then automatically performs a corresponding number of upshifts when the appropriate shift points are reached. So, for example, when starting off in 1st gear, if three + selections are made in quick succession, the TCM will automatically change up through the box to 4th gear as the vehicle accelerates, without any further selections being made.

In manual mode a low gear can be selected to provide engine braking for descending a slope without HDC or continuous use of the brake pedal. The driver can prepare for the end of the descent by moving the selector lever to D. The TCM will maintain the low gear and only revert to automatic shift control when the throttle is opened and vehicle speed increases.

Adaptive Shift Strategy (ASIS)

The ASIS system is a new feature on automatic transmissions. With the TCM linked via the CAN bus to other vehicle systems, signals are received which can allow the TCM to calculate the way in which the vehicle is being driven. The type of signals include the following:

- Longitudinal and lateral acceleration
- Engine speed
- Engine torque
- Oil temperature
- Accelerator pedal position
- Wheel speed.

Using these signals, additional transmission control can be obtained. The TCM can calculate when the vehicle is cornering, all wheels are gripping, the driver is braking or if the driver is accelerating. This is the conventional 'Adaptive' transmission control. ASIS uses this system but adds the continuous adaptation of the gear changes to the individual driving style of the driver.

HDC Mode

The HDC mode assists the ABS module in controlling the downhill speed of the vehicle. When HDC is selected on, the ABS module selects the most appropriate gear for the descent, to maximise engine braking.

Cruise Mode

When speed control is activated, the TCM receives a cruise active message on the CAN bus. The TCM activates a speed control map which prevents locking and unlocking of the torque converter clutch and minimises up and down shifts.

Hill Mode

Hill mode is initiated by the TCM when the engine torque, via ECM signals on the CAN bus, exceeds the theoretical load curve for normal operation. The TCM monitors this signal to determine when the vehicle is travelling up or down a steep gradient.

In hill mode the TCM adopts one of four shift maps, three uphill and one downhill. The shift map chosen depends on the severity of the slope as determined from the engine signals and the appropriate gear is selected to assist with the ascent or descent.

Hill mode can also be initiated when the vehicle is at very high altitudes or ambient temperatures, and also when the vehicle is towing.

Default (Limp Home) Mode

If a transmission fault is detected by the TCM, the TCM adopts a limp home mode strategy. 'TRANS. FAILSAFE' is displayed in the message centre and, if the fault has an effect on engine emissions, the MIL will also be illuminated.

In default mode, P, R and N functions operate normally (if the fault allows these selections) and the TCM locks the transmission in 3rd or 5th gear to allow the driver to take the vehicle to the nearest dealer. The torque converter lock-up clutch is disabled and reverse lock-out will not function.

If the vehicle is stopped and subsequently restarted in the default mode condition, the TCM operates normally until the fault which caused the condition is detected again.

When limp home mode is active, the gear position indicator will show one of the following letters which defines the fault type:

- 'F' - transmission is operating in limp home mode
- 'H' - transmission has reached overheat threshold temperature and transmission is operating in limp home mode
- 'E' - CAN bus is off and transmission is operating in limp home mode.

If electrical power is lost and the transmission is operating in mechanical limp home mode, the selector lever will not be locked in the 'N' position by the shift interlock solenoid. The lever will be locked in the 'P' position and can only be released by using the interlock emergency release lever or by correcting the electrical fault.

Reverse Lock-Out Mode

When the vehicle is travelling forwards, selecting reverse could cause transmission damage. To protect against this, reverse gear is prohibited if the vehicle is travelling forwards at a road speed above 5 mph (8 km/h).

Cooling Strategy

The purpose of the cooling strategy is to reduce engine and transmission temperatures during high load conditions, when towing a trailer for example. Under these conditions the engine and transmission may generate excessive heat.

If the transmission fluid temperature increases to 125°C (257°F) or higher, the TCM employs the cooling strategy. The message 'TRANSMISSION OVERHEAT' is displayed in the message center.

The strategy uses a specific shift and torque converter lock-up clutch map. This map allows torque converter clutch lock-up and gear shifts to operate outside of their normal operation. This will reduce the engine speed and/or slip in the torque converter, therefore reducing heat generated by the engine and the transmission.

If the transmission fluid temperature increases to 137°C (278°F) or higher, the transmission will use the default (limp home mode). 'H' is displayed in the gear position indicator. If the temperature exceeds 140°C (284°F), CAN bus transmission is disabled and 'E' is displayed in the gear position indicator.

The cooling strategy is cancelled when the transmission fluid temperature decreases to less than 120°C (248°F) or below.

Curve Recognition

Curve recognition is activated when high levels of lateral acceleration and/or steering angle are detected via the ABS module and steering angle sensor signals on the CAN bus. When this condition is detected, the TCM prevents the transmission from changing to a higher gear to assist with cornering. When the vehicle completes its manoeuvre, the transmission will shift to the correct ratio.

Fast Off Recognition

Fast off recognition is activated when the TCM detects that the driver has backed off the accelerator pedal quickly in a 'change of mind' manoeuvre. This is detected by monitoring for a high level of negative pedal angle from the engine

control module signal on the CAN bus. If this condition is detected, the TCM holds the current gear ratio to allow the driver to complete his original action without the need for a downshift. The mode remains active for a predetermined time period or if the driving style remains passive.

Terrain Response™ Mode

If the vehicle has the Terrain Response system fitted, the following additional modes are available. For additional information, refer to: Ride and Handling Optimization (204-06 Ride and Handling Optimization, Description and Operation).

Grass/Gravel/Snow

When the driver selects the Terrain Response grass/gravel/snow special program with the transfer box in either high or low range, the TCM uses a specific set of shift and torque converter maps to optimise the delivery of torque to the wheels and to minimise wheel slip in these terrains. To assist with the vehicle moving from a standstill, the TCM automatically selects 2nd gear in high range and 3rd gear in low range. This special program is fully integrated with hill mode to enhance vehicle control during ascents and descents.

Mud/Ruts

When the driver selects the Terrain Response mud/ruts special program with the transfer box in either high or low range, the TCM uses a specific set of shift and torque converter maps to optimise vehicle traction in this terrain.

Sand

When the driver selects the Terrain Response sand special program with the transfer box in either high or low range, the TCM uses a specific set of shift and torque converter maps to optimise the tractive performance in sand by holding onto gears longer and downshifting more readily. This mode is fully integrated with the hill mode to further enhance performance during ascents.

Rock Crawl

When the driver selects the Terrain Response rock crawl special program, which is only available with the transfer box in low range, the TCM uses a specific shift map which maximises torque delivery at slow speeds associated with this type of terrain.

TRANSMISSION FAULT STATUS

If the TCM detects a fault with the transmission system, it will enter a default mode to prevent further damage to the transmission and allow the vehicle to be driven.

When a fault is detected a CAN message is sent from the TCM and is received by the instrument cluster. The instrument cluster illuminates the MIL and displays 'TRANS. FAILSAFE' in the message centre.

Some transmission faults may not illuminate the MIL or display a fault message, but the driver may notice a reduction in shift quality.

ENGINE SPEED AND TORQUE MONITORING

The ECM constantly supplies the TCM with information on engine speed and torque through messages on the CAN bus. The TCM uses this information to calculate the correct and appropriate timing of shift changes.

If the messages are not received by the ECM, the TCM will implement a back-up strategy to protect the transmission from damage and allow the vehicle to be driven.

In the event of an engine speed or torque signal failure, the transmission will adopt the electrical limp home mode with the transmission operating in a fixed gear.

TOWING FOR RECOVERY

The following procedure must be used to ensure that the vehicle is towed in a safe condition and damage to the vehicle transmission systems is prevented.

- Secure the towing attachment from the recovery vehicle to the towing eye of the vehicle to be recovered.
- Make sure that the hand brake is on. Turn the ignition key to the ignition position II.
- Apply the footbrake and move the automatic transmission selector lever to the neutral position. If electrical power is not available, use the manual interlock release tab on the selector lever to move the lever to the neutral position.
- Make sure that the ignition is in the auxiliary position I or, if the stop lamps and turn signal indicators are required, in the ignition position II.
- Make sure that the hand brake is released before the vehicle is towed.
- The vehicle can only be towed for a maximum of 31 miles (50 km) at a maximum speed of 30 mph (50 km/h). Towing the vehicle for longer distances and/or faster speeds will damage the transmission.



WARNING: Do not remove the key or move the ignition switch to position 'O' when the vehicle is being towed. The steering lock will be engaged preventing the steering from being turned.

With the engine not running, the brake booster and power steering pump will be inoperative. Care must be taken to ensure the vehicle is manoeuvred and driven accordingly.

CONTROL DIAGRAM

- **NOTE:** **A** = Hardwired; **D**= High Speed CAN Bus

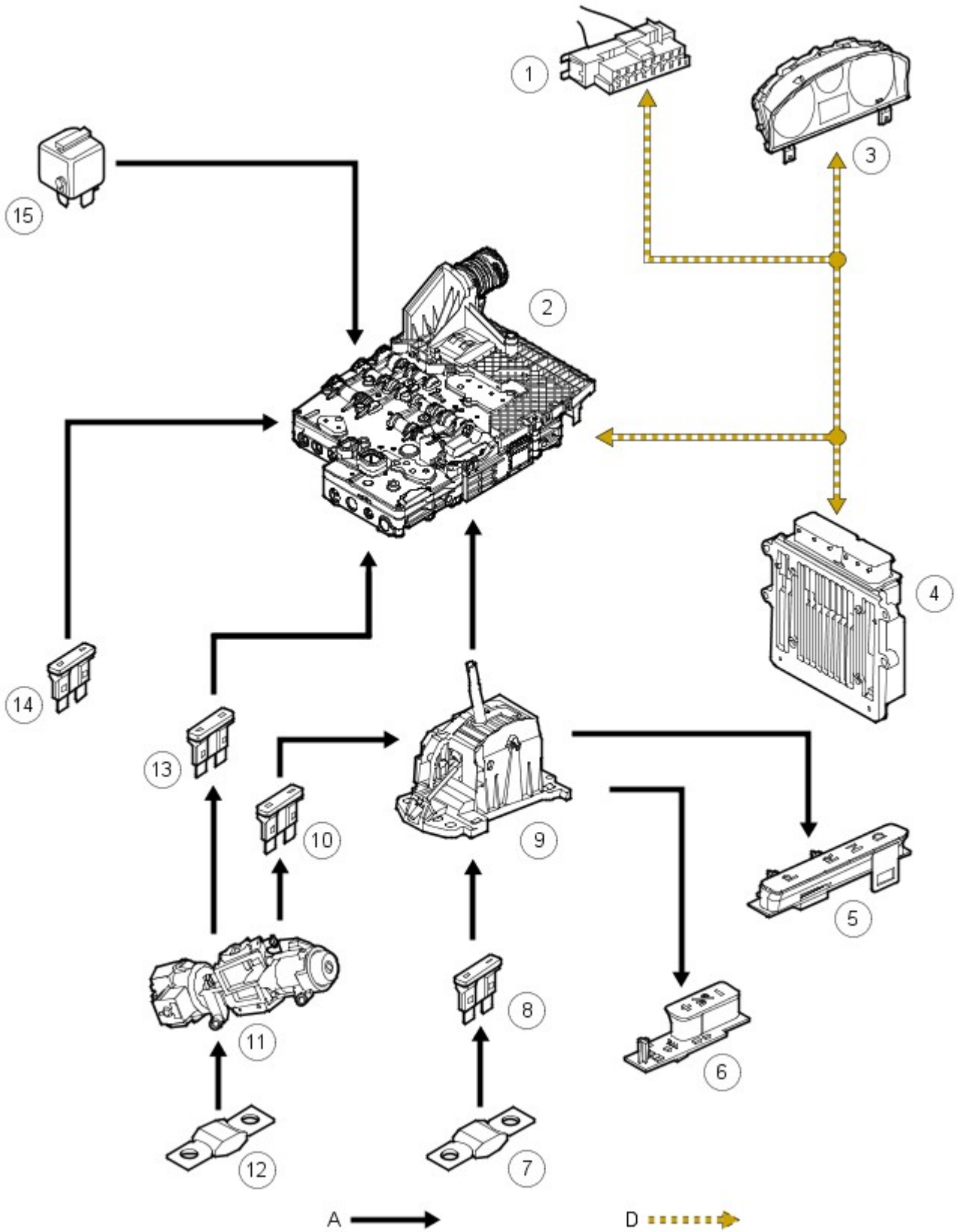

E42395

Item	Part Number	Description
1	-	Diagnostic socket
2	-	Mechatronic Valve (including TCM, sensors and solenoids)
3	-	Instrument cluster
4	-	Engine Control Module (ECM)
5	-	Selector indicator
6	-	Selector indicator
7	-	Fusible link 7E (50A)
8	-	Fuse 43P (5A)
9	-	Selector lever assembly
10	-	Fuse 33P (5A)
11	-	Ignition switch

12	-	Fusible link 10E (30A)
13	-	Fuse 27P (5A) - Ignition feed
14	-	Fuse 4E (10A) - Permanent feed
15	-	Starter relay

Automatic Transmission/Transaxle - V6 4.0L Petrol - Automatic Transmission

Diagnosis and Testing

Principle of Operation

For detailed description of the automatic transmission system and operation, refer to the relevant Description and Operation section of the workshop manual. REFER to: [Automatic Transmission](#) (307-01B Automatic Transmission/Transaxle - V6 4.0L Petrol, Description and Operation).

Inspection and Verification

This section is intended to provide a means for the technician to diagnose transmission component faults, rather than replacing the entire unit.

However, there are a number of situations where the replacement of the unit is the only practical solution, and this section will cover the diagnosis necessary to gather the information required for transmission replacement to be authorized by the warranty prior approval program (WPAP) where it applies, as well as covering the diagnostic trouble codes (DTCs) stored by the control module.

The basic checks of the transmission (fluid condition and level, etc) should be carried out first, and this will mean using the approved diagnostic system or other equipment with data logging facility to monitor temperatures, etc.

For information on the operation of the transmission, refer to the relevant workshop manual section.

1. **1.** Verify the customer concern.
2. **2.** Visually inspect for obvious signs of mechanical or electrical damage.

Visual Inspection

Mechanical	Electrical
<ul style="list-style-type: none"> ● Fluid condition ● Fluid level ● Fluid leaks ● Fluid cooler ● External linkages ● Gear selector lever 	<ul style="list-style-type: none"> ● Fuses ● Wiring harnesses ● Electrical connector(s) ● Transmission control module (TCM) ● Engine control module (ECM)

3. **3.** If an obvious cause for an observed or reported concern is found, correct the cause (if possible) before proceeding to the next step.
4. **4.** Use the approved diagnostic system or a scan tool to retrieve any DTCs before moving onto the DTC index.
 - Because the DTCs are stored in more than one module, a complete vehicle read is recommended
 - Make sure that all DTCs are cleared following rectification.

Preliminary Inspection

1. **1.** As much information as possible should be obtained from the owner/driver about the fault in order to assist with the diagnosis. Time spent on this will reduce the necessity for extensive road testing and possible missed diagnosis.
 - The information required for WPAP is still useful as an aid to diagnosis, even where the system is not in operation

Required information for WPAP (where applicable)

- The nature of the fault (loss of drive, slip, judder, gear shift quality, noise, etc)
 - The frequency with which the fault occurs
 - The conditions under which the fault occurs, including temperature (coolant and ambient), selected gear, road speed, engine speed, and any specific conditions
 - Check and rectify non-transmission related DTCs before continuing with transmission diagnosis
2. **2.** Record the vehicle details, including:
 - Service history
 - The transmission serial number
 - The transmission software level
 3. **3.** Visually inspect the transmission for fluid leaks, damage, etc.
 4. **4.** Check the transmission fluid condition.

• **NOTE:** Fluid condition is a good indicator of the transmission internal condition. If the fluid is burnt and/or contaminated, this would usually mean the internal damage to the transmission is at such a level that unit replacement is the best option. Compare the fluid drained from the transmission with fresh fluid for color and odor.

5. **5.** Check the transmission fluid level. Refer to the relevant workshop manual section.

• **NOTE:** This is crucial to the operation of the transmission, and the procedure must be closely followed to avoid inaccurate diagnosis, with the resultant possible rejection of a warranty claim.

6. **6.** Check the engine idle speed and throttle sensor using the approved diagnostic system or a scan tool.
7. **7.** Check the transmission selector cable adjustment. Refer to the relevant workshop manual section.
8. **8.** Check the transmission range sensor adjustment.

- A comprehensive procedure for transmission range sensor setting is accessible through the approved diagnostic system.

If any faults are found and rectified in the above sequence, clear any DTCs and test the vehicle for normal operation.

If a failure condition is found indicating the need to renew the transmission assembly, the request must go through the warranty prior approval program (where applicable) before work is begun.

DTC Index

For a list of Diagnostic Trouble Codes (DTCs) that could be logged on this vehicle, please refer to Section 100-00. REFER to: [Diagnostic Trouble Code \(DTC\) Index - DTC: Transmission Control Module \(TCM\) - Bosch](#) (100-00 General Information, Description and Operation).

Automatic Transmission/Transaxle - V6 4.0L Petrol - Transmission Fluid Drain and Refill

General Procedures

• **WARNINGS:**



Observe due care when draining transmission fluid as the fluid can be very hot.



Observe due care when working near a hot exhaust system.

All vehicles

1.  **WARNING:** Do not work on or under a vehicle supported only by a jack. Always support the vehicle on safety stands.

Raise and support the vehicle.

2. Remove the transmission undershield.
 - Remove the 6 bolts.

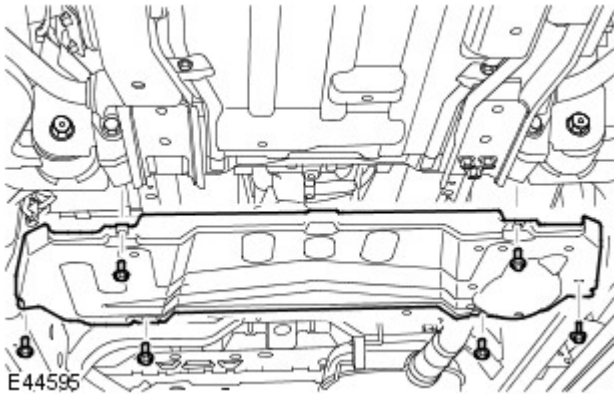

3. If installed, remove the transmission heat shield.
 - Remove the 4 bolts.

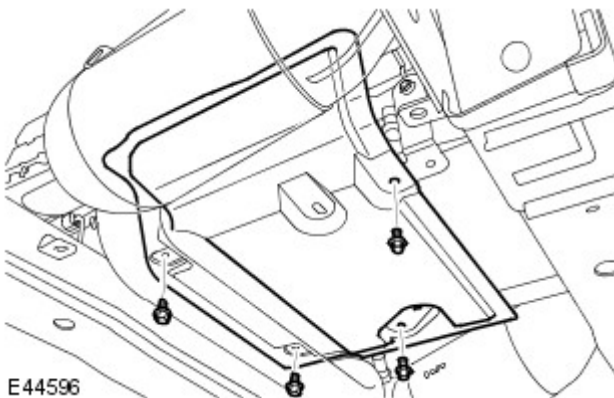

Vehicles with 4.0L engine

4. Remove the transmission support insulator through-bolt.
 - Raise the transmission to gain access to the fluid drain plug.

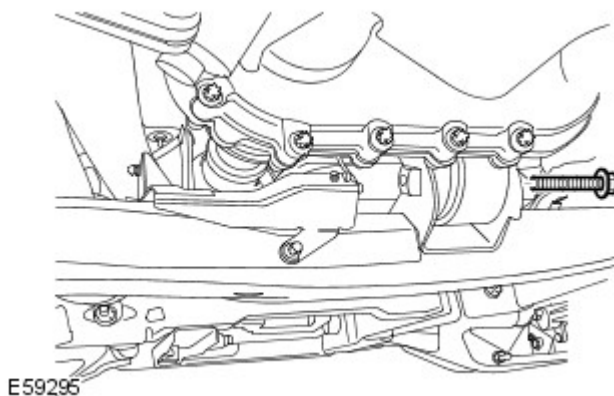

All vehicles

5. Clean the area around the transmission fluid drain and filler plugs.
6. Place a container under the transmission.



7. WARNINGS:



Observe due care when draining transmission fluid as the fluid can be very hot.



Observe due care when working near a hot exhaust system.

Remove the transmission fluid filler/level plug.

- Remove and discard the sealing washer.



8. Remove the transmission fluid drain plug.

- Remove and discard the sealing washer.
- Allow the fluid to drain.

9. Install the transmission fluid drain plug and tighten to 9 Nm (7 lb.ft).

- Install a new sealing washer.

Vehicles with 4.0L engine

10. Install the transmission support insulator through-bolt and tighten to 175 Nm (129 lb.ft).

- Lower the transmission.

All vehicles

11. Add 3.5 to 4 litres of the correct transmission fluid, or until a small thread of fluid runs from the filler/level hole.

12. Check and top-up the transmission fluid level.

For additional information, refer to: [Transmission Fluid Level Check](#) (307-01A Automatic Transmission/Transaxle - TDV6 2.7L Diesel, General Procedures).

Automatic Transmission/Transaxle - V6 4.0L Petrol - Transmission Fluid Level Check

General Procedures

• **WARNINGS:**



Observe due care when draining transmission fluid as the fluid can be very hot.



Observe due care when working near a hot exhaust system.



CAUTION: The gearbox fluid level must only be checked when the temperature of the fluid is between 30 degrees and 50 degrees. The fluid level obtained will be incorrect if the reading is outside this temperature range.

1. The following steps must be observed before starting the transmission fluid level check and top-up.

- The vehicle must be on a horizontal ramp.
- The parking brake must be applied.
- The wheels must be chocked.



2. **CAUTION:** Make sure the transmission fluid temperature is below 30 degrees before starting the fluid level check.

Using the approved Land Rover diagnostic equipment, monitor the transmission fluid temperature.

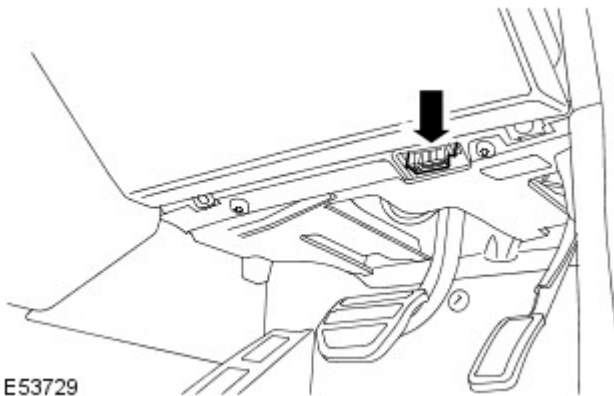

E53729

3. Start the engine. Move the selector lever from 'P' through all gear positions, pausing in each gear position for 2-3 seconds and return to the 'P' position.

4.  **WARNING:** Do not work on or under a vehicle supported only by a jack. Always support the vehicle on safety stands.

Raise and support the vehicle.

5. Remove the transmission undershield.

- Remove the 6 bolts.

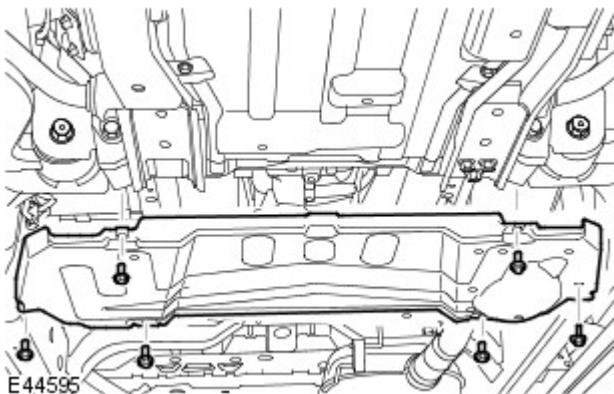

E44595

6. If installed, remove the transmission heat shield.

- Remove the 4 bolts.

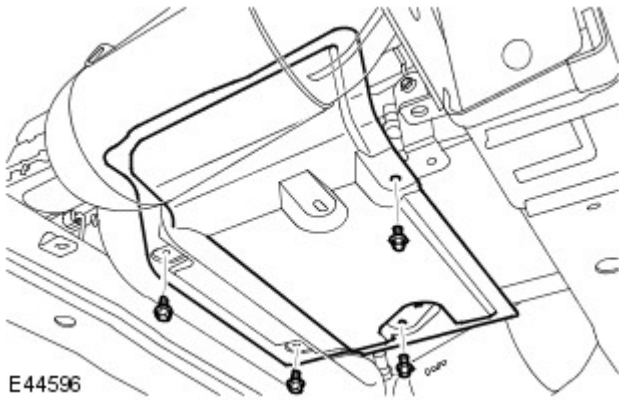

7. Place a container under the transmission.

8. WARNINGS:

 Observe due care when draining transmission fluid as the fluid can be very hot.

 Observe due care when working near a hot exhaust system.

 CAUTION: The gearbox fluid level must only be checked when the temperature of the fluid is between 30 degrees and 50 degrees. The fluid level obtained will be incorrect if the reading is outside this temperature range.

Remove the transmission fluid filler/level plug.

- Clean the area around the filler/level plug.
- Remove and discard the sealing washer.

9. If no fluid loss is apparent when the filler/level plug is removed, with the engine at idle, continue to fill the transmission until a small thread of oil runs from oil filler/level hole.

10. Install the transmission fluid filler/level plug and tighten to 35 Nm (26 lb.ft).

- Install a new sealing washer.
- Remove the container.

11. If installed, install the transmission heat shield.

- Tighten the bolts to 10 Nm (7 lb.ft).

12. Install the transmission undershield.



- Tighten the bolts to 10 Nm (7 lb.ft).

13. Disconnect the approved Land Rover diagnostic equipment from the vehicle.



Automatic Transmission/Transaxle - V6 4.0L Petrol - Selector Shaft Seal

In-vehicle Repair

Special Tool(s)	
 <p>307-509-1 E50766</p>	<p>ZF Automatic transmission selector shaft seal remover 307-509-1 (LRT-44-033/1)</p>
 <p>307-509-2 E50767</p>	<p>ZF Automatic transmission selector shaft seal remover 307-509-2 (LRT-44-033/2)</p>
 <p>307-509-3 E50768</p>	<p>ZF Automatic transmission selector shaft seal installer 307-509-3 (LRT-44-033/3)</p>

Removal

-  **WARNING:** Do not work on or under a vehicle supported only by a jack. Always support the vehicle on safety stands.

Raise and support the vehicle.

- LH selector shaft seal only: Remove the exhaust system. For additional information, refer to: [Exhaust System](#) (309-00C Exhaust System - V6 4.0L Petrol, Removal and Installation).
- Remove the transmission heat shield.
 - Remove the 4 bolts.

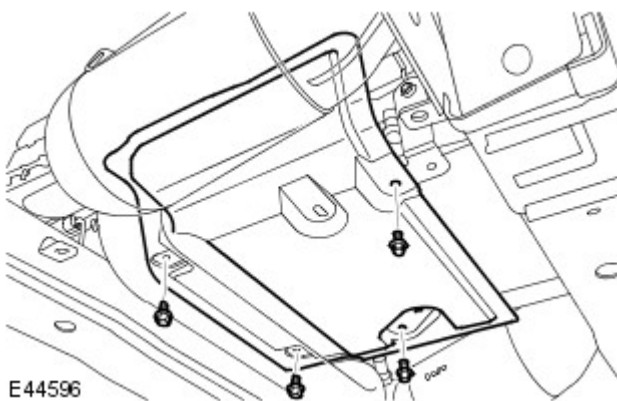

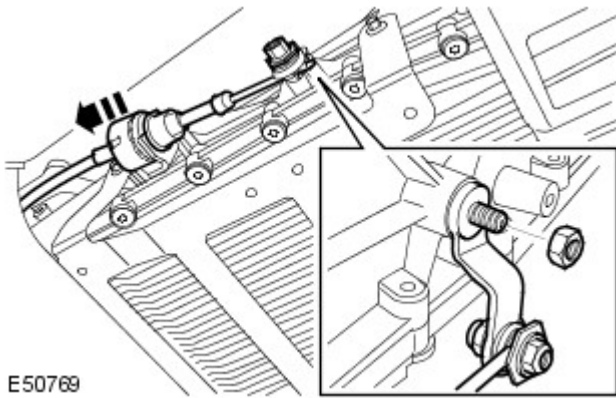



E50769

4. Release the selector cable and lever.

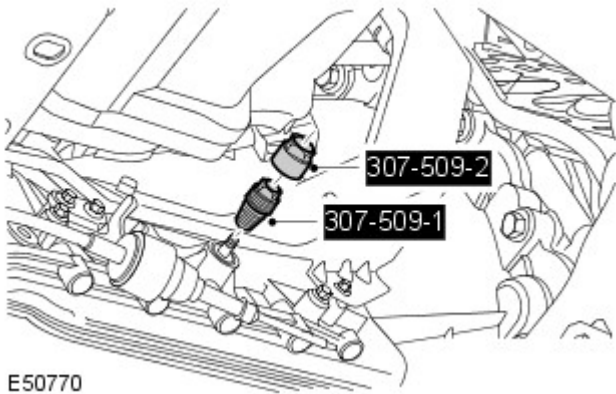
- Remove the nut.
- Compress the latch and release the cable.



E50770

5.  **CAUTION:** Before the disconnection or removal of any components, ensure the area around joint faces and connections are clean. Plug any open connections to prevent contamination.

Remove the selector shaft seal.

- Install 307-509-1 to the seal.
- Install 307-509-2 to 307-509-1 and extract the seal.

Installation

1. Using 307-509-3, install the selector shaft seal.

- Clean the components.

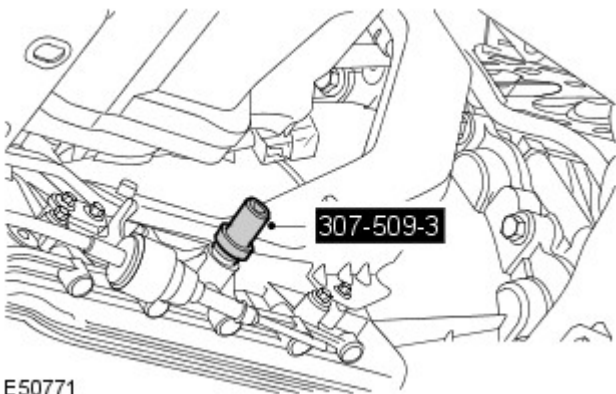

E50771

2. Install the selector cable and bracket.

- Secure with the clip.
- Tighten the nut to 12 Nm (9 lb.ft).

3. Install the transmission heat shield.

- Install the bolts.

4. LH selector shaft seal only: Install the exhaust system.
For additional information, refer to: [Exhaust System](#) (309-00C Exhaust System - V6 4.0L Petrol, Removal and Installation).

Automatic Transmission/Transaxle - V6 4.0L Petrol - Transmission Control Module (TCM)

In-vehicle Repair

Special Tool(s)	
 <p>E48903</p>	ZF Automatic transmission valve block seals remover 307-492 (LRT-44-005)

Removal

- NOTE: The transmission control module (TCM) is part of the main control valve body and cannot be serviced separately.

-  **WARNING:** Do not work on or under a vehicle supported only by a jack. Always support the vehicle on safety stands.

Raise and support the vehicle.

- Remove the fluid pan.
For additional information, refer to: [Fluid Pan, Gasket and Filter](#) (307-01B Automatic Transmission/Transaxle - V6 4.0L Petrol, In-vehicle Repair).
- Disconnect the electrical connector.

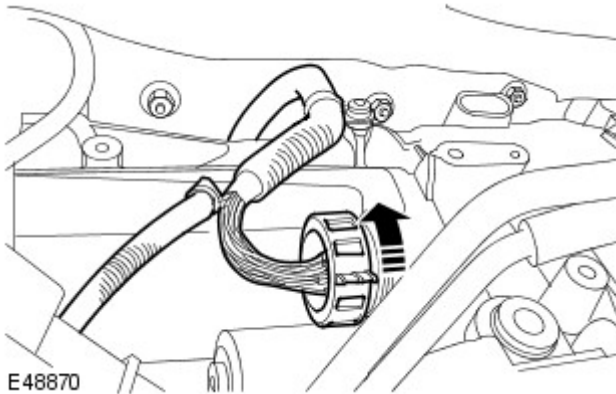

- Remove and discard the electrical connector sleeve.

- Release the retainer.

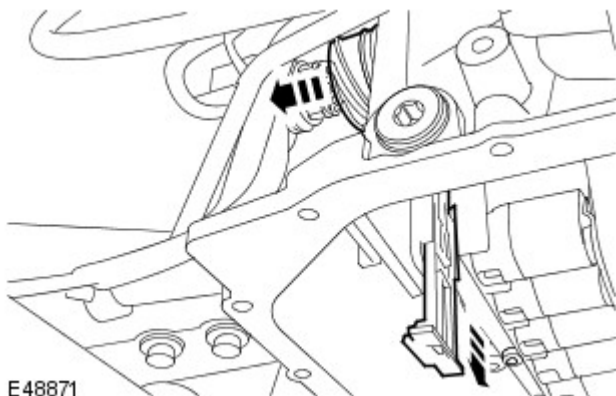

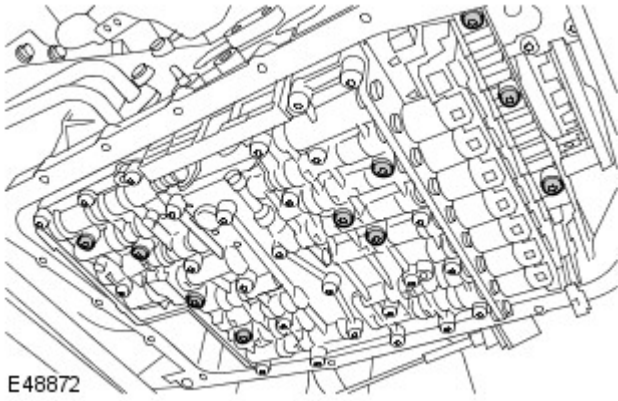

5. Remove the valve body.

- Position a container to collect spillage.
- Remove the 10 Torx screws.

- 6. Using the special tool, remove the 4 seals.**
7. Remove the seal block.

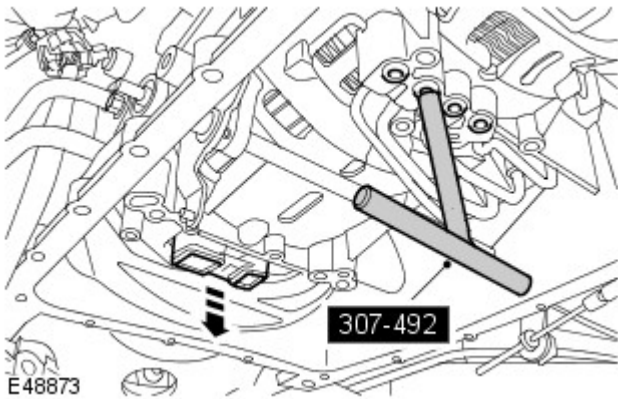

Installation

1. CAUTIONS:

- ⚠ Make sure that when fully fitted, all seals protrude by the same amount.
- ⚠ Engage the selector lever with the groove in the piston rod.

Install the valve body.

- Clean the component mating faces.
- Install new seals.
- Install a new seal block.
- Tighten the Torx screws to 8 Nm (6 lb.ft).

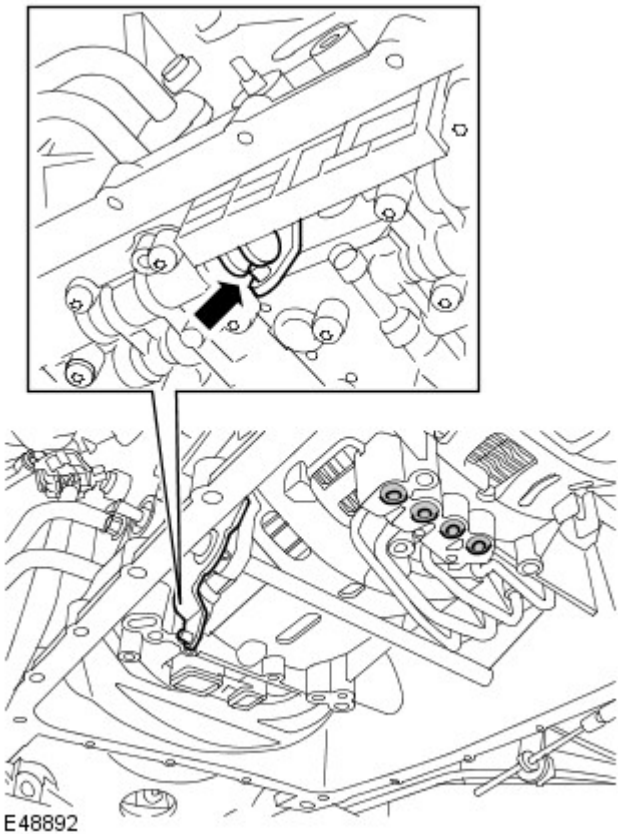

- 2. Install a new electrical connector sleeve.**

- Secure with retainer.

3. Connect the electrical connector.



4. Install the fluid pan.

For additional information, refer to: [Fluid Pan, Gasket and Filter](#) (307-01B Automatic Transmission/Transaxle - V6 4.0L Petrol, In-vehicle Repair).

5. Calibrate a new main control valve body using T4.

Automatic Transmission/Transaxle - V6 4.0L Petrol - Output Shaft Seal

In-vehicle Repair

Special Tool(s)	
 <p>303-903 E50940</p>	<p>Oil seal remover 303-903 (LRT-12-092)</p>
 <p>307-520 E52536</p>	<p>Oil seal installer 307-520</p>

Removal

-  **WARNING:** Do not work on or under a vehicle supported only by a jack. Always support the vehicle on safety stands.

Raise and support the vehicle.

- Remove the transfer case.
For additional information, refer to: [Transfer Case - V6 4.0L Petrol](#) (308-07B Transfer Case, Removal).

-  **CAUTION:** Care must be taken to avoid damage to the seal register and running surface.

Remove the transmission output shaft oil seal.

- Use the special tool.

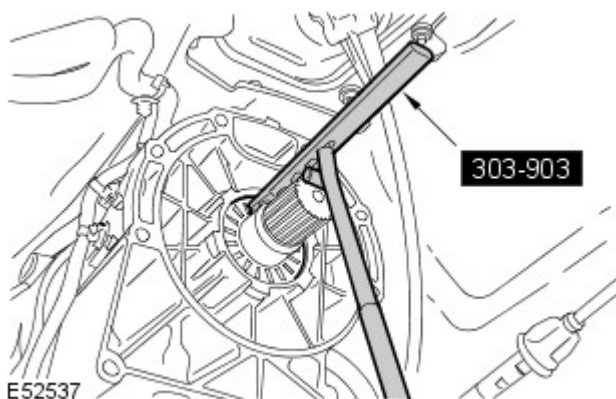

Installation

-  **CAUTION:** Oil seals must be fitted dry.

Install a new transmission output shaft oil seal.

- Clean the seal register.
- Use the special tool.

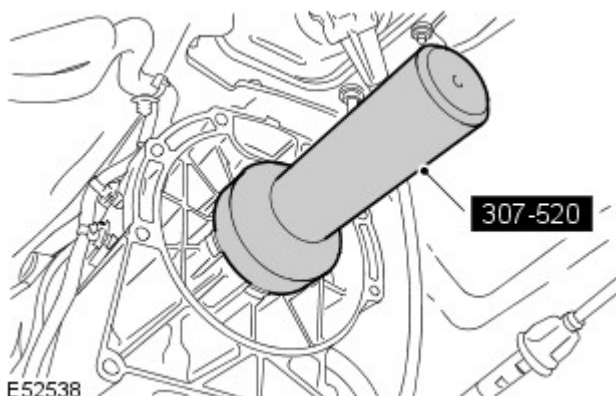

- Install the transfer case.
For additional information, refer to: [Transfer Case - V6 4.0L](#)

[Petrol](#) (308-07B Transfer Case, Removal).

3. Check and top-up the transmission fluid level.
For additional information, refer to: [Transmission Fluid Level Check](#) (307-01A Automatic Transmission/Transaxle - TDV6 2.7L Diesel, General Procedures).

Automatic Transmission/Transaxle - V6 4.0L Petrol - Fluid Pan, Gasket and Filter

In-vehicle Repair

Removal

1. Disconnect the battery ground cable.
For additional information, refer to: [Specifications](#) (414-00 Battery and Charging System - General Information, Specifications).
2. Remove the engine cover.
For additional information, refer to: [Engine Cover - V6 4.0L Petrol](#) (501-05 Interior Trim and Ornamentation, Removal and Installation).

3.  **WARNING:** Do not work on or under a vehicle supported only by a jack. Always support the vehicle on safety stands.

Raise and support the vehicle.

4. Remove the exhaust system.
For additional information, refer to: [Exhaust System](#) (309-00C Exhaust System - V6 4.0L Petrol, Removal and Installation).
5. Remove the transmission support insulator.

- Remove the 4 bolts.

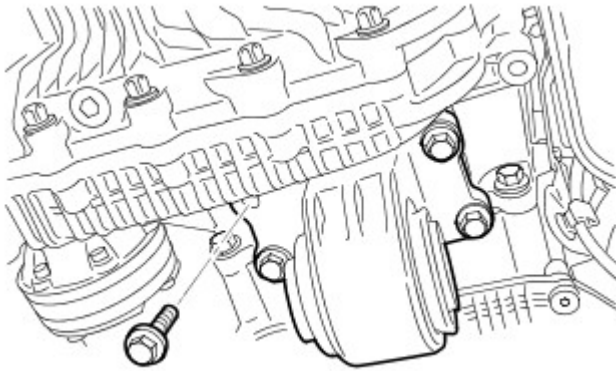

E54739

6. Remove the transmission heat shield.

- Remove the 4 bolts.

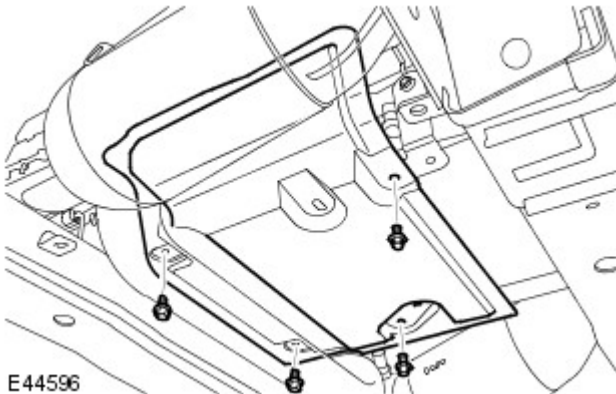

E44596

7. Release the selector cable from its abutment bracket.
8. Drain the transmission.
9. Remove the transmission heat shield bracket.
For additional information, refer to: [Transmission Fluid Drain and Refill](#) (307-01A Automatic Transmission/Transaxle - TDV6 2.7L Diesel, General Procedures).

- Remove the 4 bolts.

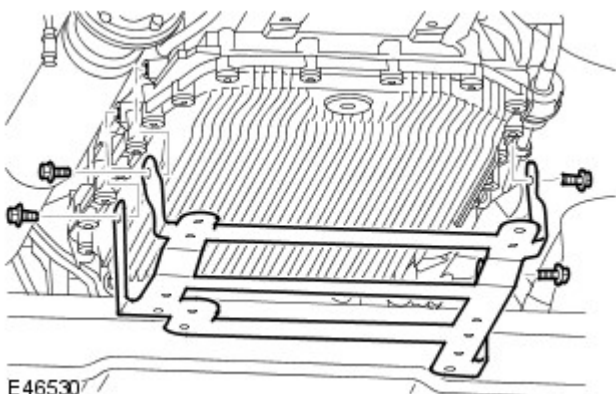

E46530

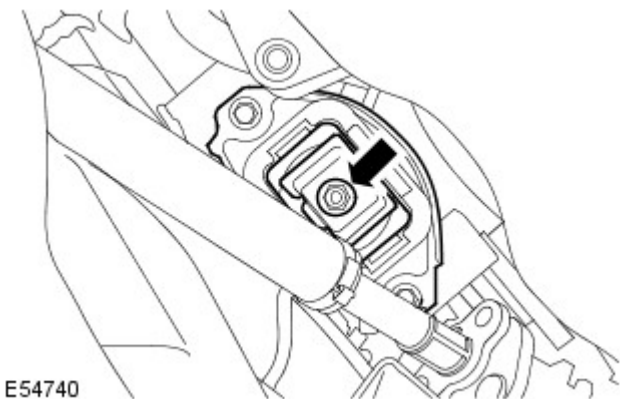

E54740

10.  **CAUTION:** Protect the engine during this operation.

Raise the RH side of the engine by approximately 15 mm.

- Remove the nut.
- Use a transmission jack.

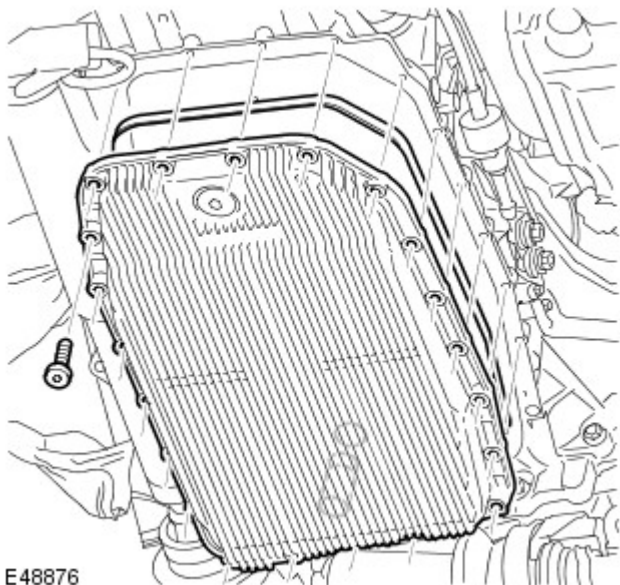

E48876

11. Remove the fluid pan.

- Position a container to collect the fluid spillage.
- Remove the 21 Torx screws.
- Remove and if necessary, discard the seal.
- Discard the O-ring seal.

Installation

- 1.** Install the fluid pan.
 - Clean the components.
 - Install the seal.
 - Install a new O-ring seal.
 - Tighten the Torx screws to 8 Nm (6 lb.ft).
- 2.** Lower the RH side of the engine.
 - Remove the engine support.
 - Tighten the nut to 90 Nm (66 lb.ft).
- 3.** Install the transmission heat shield bracket.
 - Tighten the 4 bolts to 10 Nm (7 lb.ft).
 - Install the selector cable to its abutment bracket.
- 4.** Install the selector cable to its abutment bracket.
- 5.** Install the transmission heat shield.
 - Tighten the bolts to 10 Nm (7 lb.ft).
- 6.** Install the transmission support insulator.
 - Clean the component mating faces.
 - Tighten the bolts to 60 Nm (44 lb.ft).

- 7.** Install the exhaust system.
For additional information, refer to: [Exhaust System](#) (309-00C Exhaust System - V6 4.0L Petrol, Removal and Installation).
- 8.** Install the engine cover.
For additional information, refer to: [Engine Cover - V6 4.0L Petrol](#) (501-05 Interior Trim and Ornamentation, Removal and Installation).
- 9.** Connect the battery ground cable.
For additional information, refer to: [Specifications](#) (414-00 Battery and Charging System - General Information, Specifications).
- 10.** Refill the transmission with fluid.
For additional information, refer to: [Transmission Fluid Drain and Refill](#) (307-01A Automatic Transmission/Transaxle - TDV6 2.7L Diesel, General Procedures).

Automatic Transmission/Transaxle - V6 4.0L Petrol - Main Control Valve Body

In-vehicle Repair

Special Tool(s)	
 <p>E48903</p>	ZF Automatic transmission valve block seals remover 307-492 (LRT-44-005)

Removal

- NOTE: The transmission control module (TCM) is part of the main control valve body and cannot be serviced separately.

-  **WARNING:** Do not work on or under a vehicle supported only by a jack. Always support the vehicle on safety stands.

Raise and support the vehicle.

- Remove the fluid pan.
For additional information, refer to: [Fluid Pan, Gasket and Filter](#) (307-01B Automatic Transmission/Transaxle - V6 4.0L Petrol, In-vehicle Repair).
- Disconnect the electrical connector.

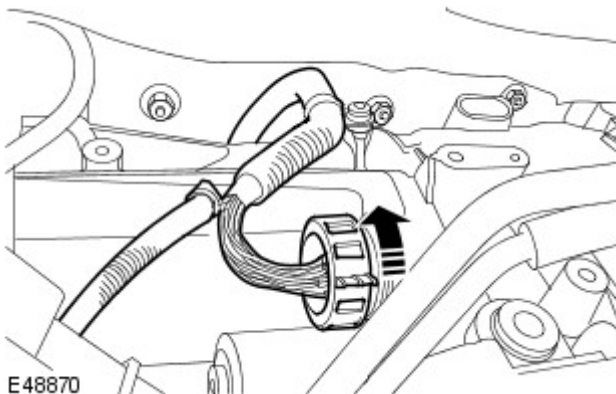

- Remove and discard the electrical connector sleeve.

- Release the retainer.

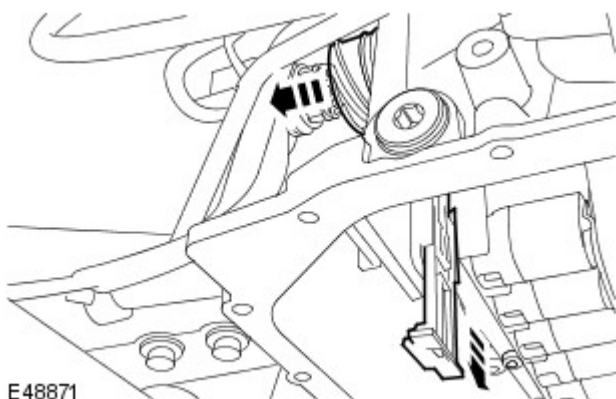

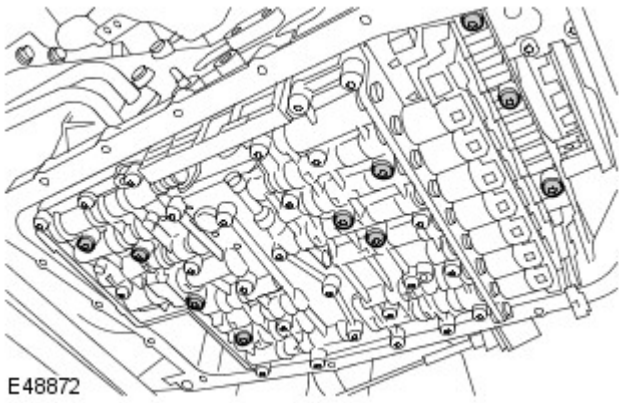

5. Remove the valve body.
- Position a container to collect spillage.
 - Remove the 10 Torx screws.

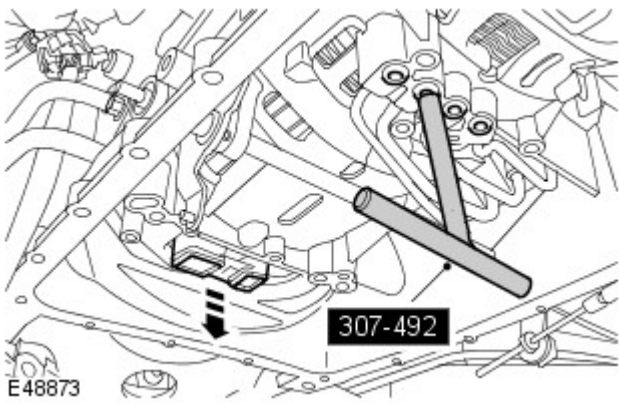

6. Using the special tool, remove the 4 seals.

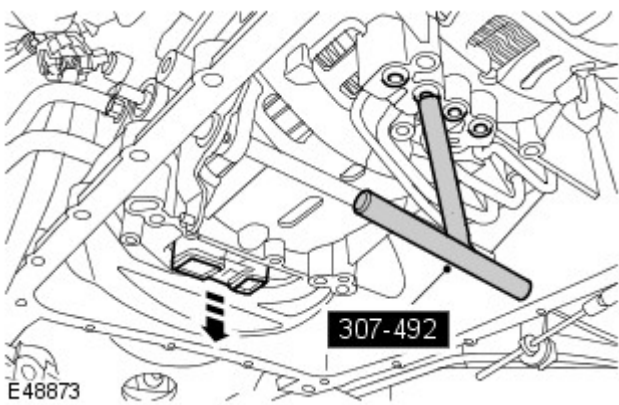

7. Remove the seal block.

Installation

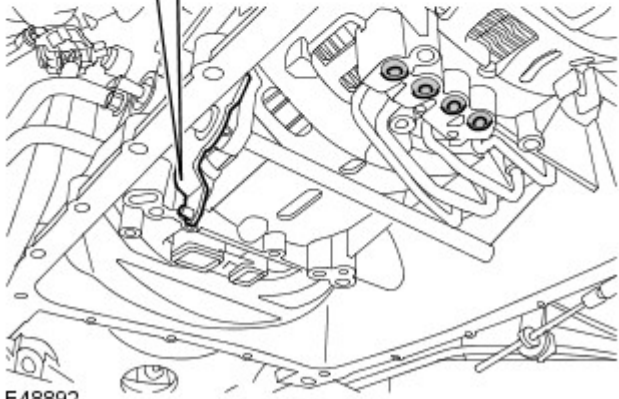
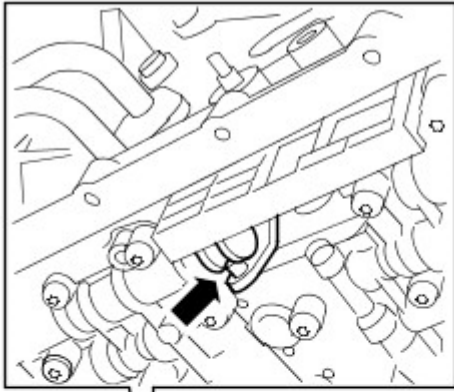

E48892

1. CAUTIONS:



Make sure that when fully fitted, all seals protrude by the same amount.



Engage the selector lever with the groove in the piston rod.

Install the valve body.

- Clean the component mating faces.
- Install new seals.
- Install a new seal block.
- Tighten the Torx screws to 8 Nm (6 lb.ft).

2. Install a new electrical connector sleeve.

- Secure with retainer.

3. Connect the electrical connector.

4. Install the fluid pan.

For additional information, refer to: [Fluid Pan, Gasket and Filter](#) (307-01B Automatic Transmission/Transaxle - V6 4.0L Petrol, In-vehicle Repair).

5. Calibrate a new main control valve body using T4.

Automatic Transmission/Transaxle - V6 4.0L Petrol - Transmission Support Insulator

In-vehicle Repair

Removal

1.  **WARNING:** Do not work on or under a vehicle supported only by a jack. Always support the vehicle on safety stands.

Raise and support the vehicle.

2. Remove the transmission crossmember.
For additional information, refer to: [Transmission Support Crossmember - V8 5.0L Petrol](#) (502-02 Full Frame and Body Mounting, Removal and Installation).

3. **NOTE:** 4.4L illustration shown, 4.0L and 2.7L Diesel are similar.

Remove the transmission support insulator.

- Remove the 4 bolts.

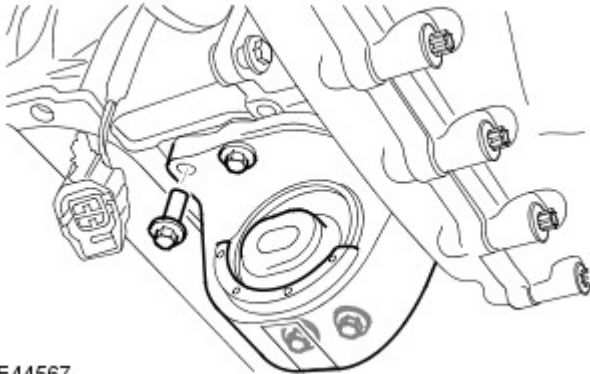

E44567

Installation

1. To install, reverse the removal procedure.
 - Clean the component mating faces.
 - Tighten the bolts to 60 Nm (44 lb.ft).

Automatic Transmission/Transaxle - V6 4.0L Petrol - Transmission

Removal and Installation

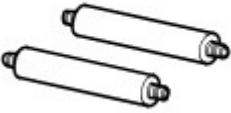
Special Tool(s)	
 <p>308-246</p> <p>E46737</p>	<p>Torque converter seal installer</p> <p>308-246</p>
 <p>307-497</p> <p>E46738</p>	<p>Torque converter support handles</p> <p>307-497 (LRT-44-010)</p>

Removal

-  **WARNING:** Do not work on or under a vehicle supported only by a jack. Always support the vehicle on safety stands.

Raise and support the vehicle.

- Remove the transfer case.
For additional information, refer to: [Transfer Case - V6 4.0L Petrol](#) (308-07B Transfer Case, Removal).
- Remove the transmission heat shield.

- Remove the 4 bolts.

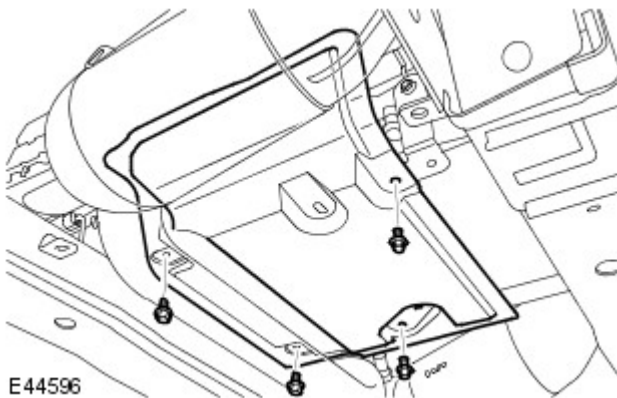

- Release the selector cable.

- Using an additional wrench, restrain the clamping bush and loosen the locknut.
- Compress the latch and release the cable.

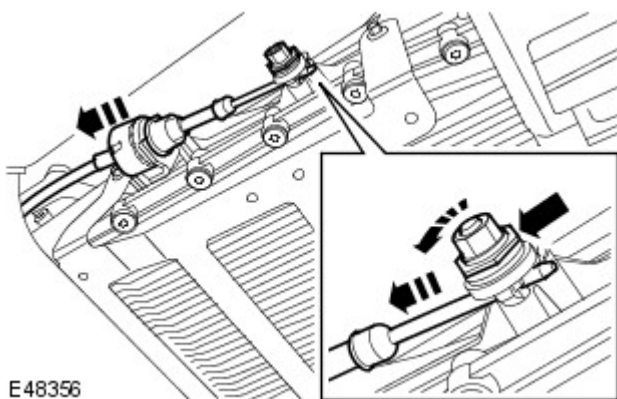

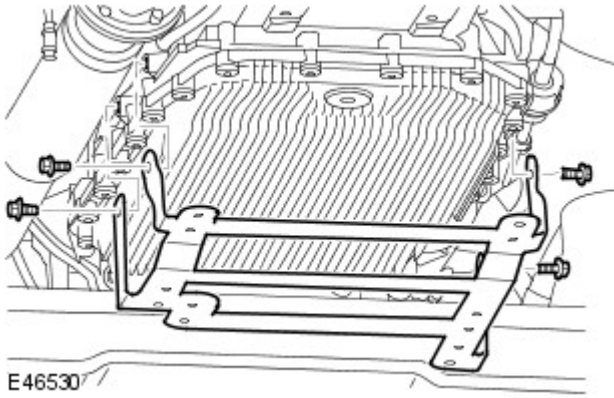

5. Remove the transmission heat shield bracket.

- Remove the 4 bolts.

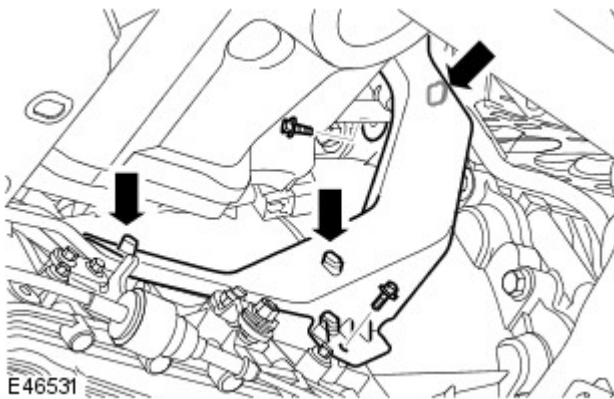

6. Remove the fuel pipe heat shield.

- Remove the 2 bolts.
- Release the fuel pipes from the 3 clips.

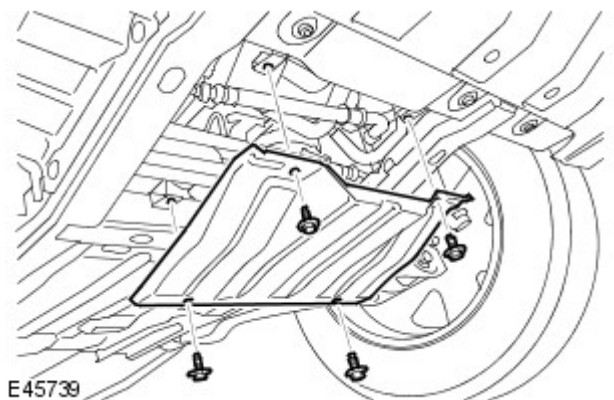

7. Remove the radiator access panel.

- Remove the 4 bolts.

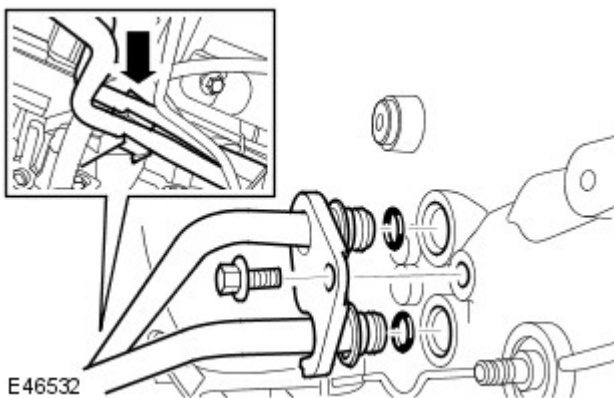

8.  CAUTION: Always plug any open connections to prevent contamination.

Release the transmission fluid lines.

- Remove the bolt.
- Release the clip.
- Remove and discard both O-ring seals.

9. Release the wiring harness from the LH side of the transmission.

- Remove the 3 Torx screws.
- Release the 2 clips.

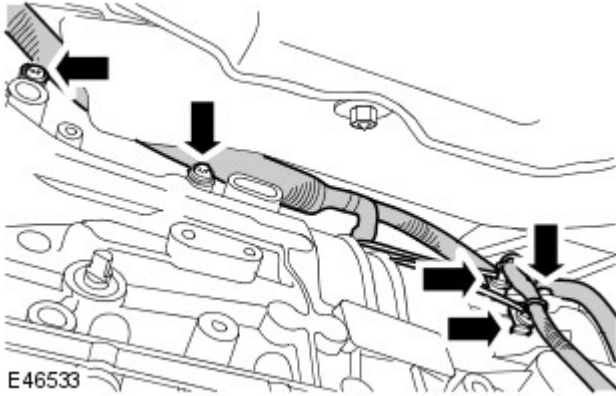

10. Release the wiring harness from the RH side of the transmission.

- Remove the Torx screw.
- Disconnect the electrical connector.

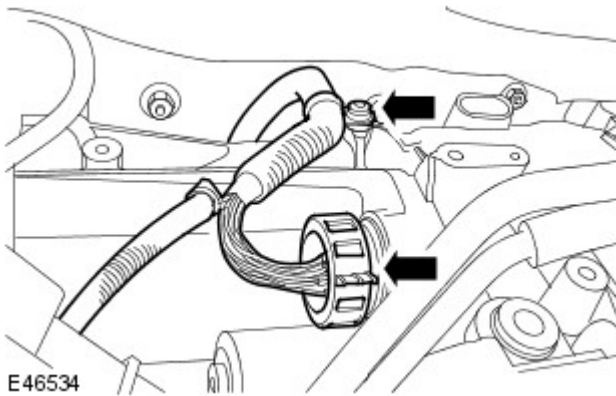

11. Release the transmission breather line clip.

- Remove the bolt.



12. Release the starter motor.

- Remove the 2 bolts.
- Tie the starter motor aside.

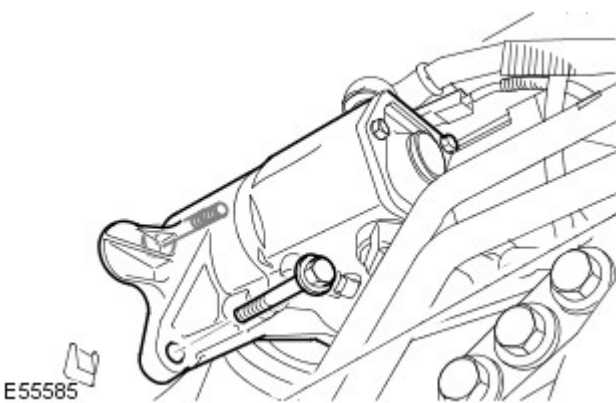

13. Release the flexplate.

- Rotate the crankshaft to access the bolts.
- Remove the 4 bolts.

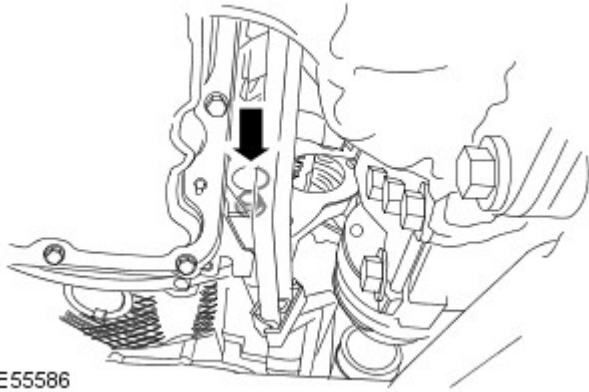

E55586

14. Remove the crankshaft position (CKP) sensor.

- Disconnect the electrical connector.
- Remove the bolt.

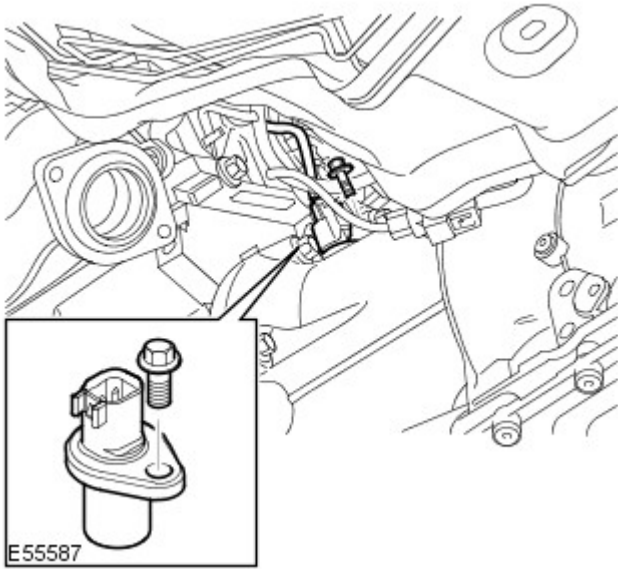

E55587

15. Remove the access hole plug.

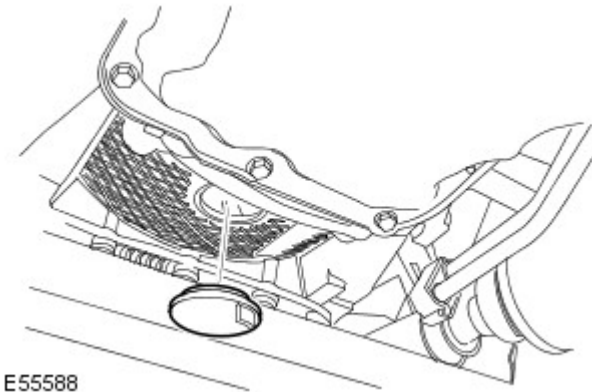

E55588

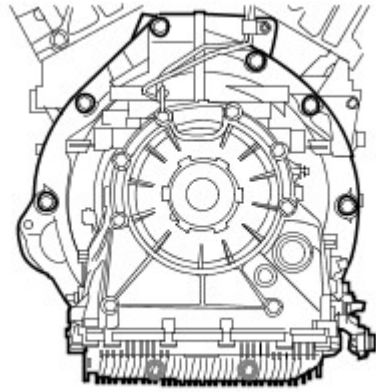

E55589

16. WARNINGS:

 Support the engine. The engine will fall forward when the transmission is removed.

 Secure the transmission to the transmission jack.

 Make sure the torque converter remains with the transmission.

With assistance, remove the transmission.

- Using a transmission jack, support the transmission.
- Remove the 8 bolts.

17. Install the torque converter retainer.

18. NOTE: Do not disassemble further if the component is removed for access only.

Remove the transmission from the transmission jack.

19. Remove the torque converter retainer.

20. Using the special tools, remove the torque converter.

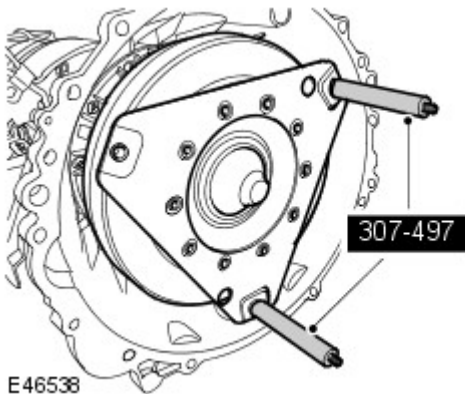

E46538

21. Carefully remove and discard the torque converter fluid seal.

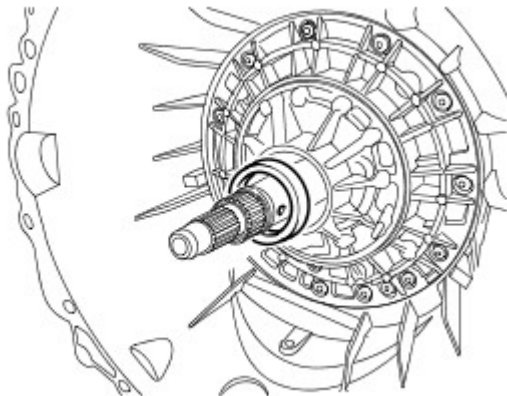

E48465

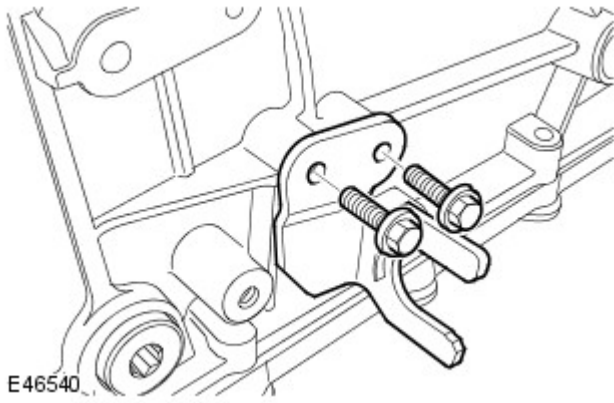

22. Remove the selector cable bracket.

- Remove the 2 bolts.

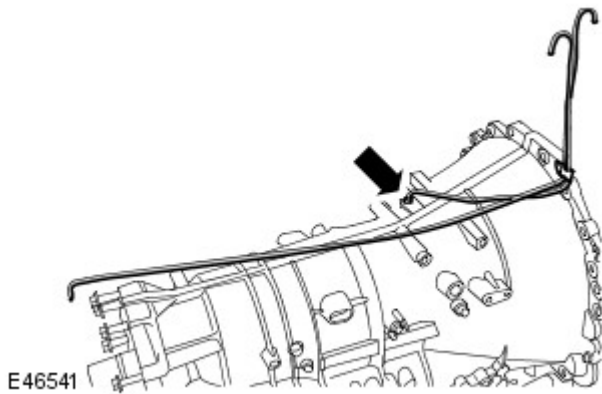

23.  **CAUTION:** Always plug any open connections to prevent contamination.

Remove the transmission breather lines.

- Depress the locking ring.

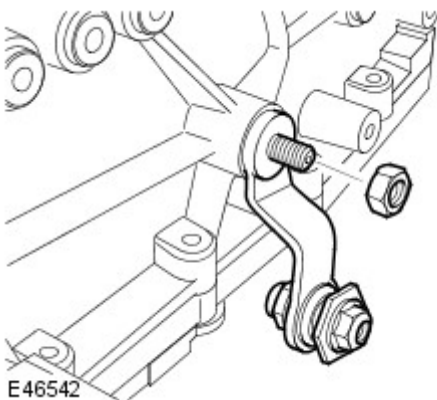

24. Remove the selector lever.

- Remove the nut.

Installation

 **CAUTION:** If the automatic transmission fluid is very dirty or it contains metallic particles, then along with a new transmission, install a new automatic transmission fluid cooler and lines.

1. Attach the selector lever.

- Tighten the nut to 12 Nm (9 lb.ft).

2. Attach the transmission breather lines.

- Secure with the clip.

3. Attach the selector cable bracket.

- Tighten the bolts to 10 Nm (7 lb.ft).

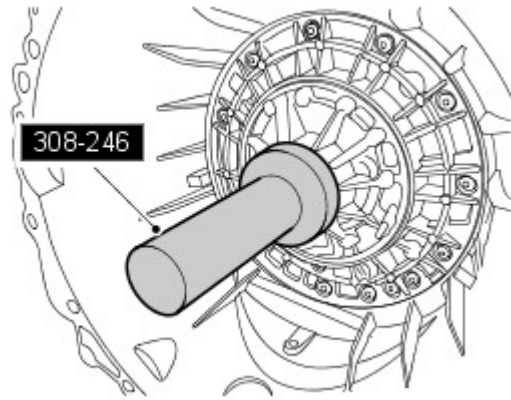

E46739

4. Using the special tool, install a new torque converter oil seal.

- Clean the seal register.

5.  **CAUTION:** Make sure the torque converter is fully located into the oil pump drive.

Install the torque converter.

- Clean the seal contact area.
- Remove the special tools.

6. Install the torque converter retainer.

7.  **WARNING:** Secure the transmission to the transmission jack.

Position the transmission to the transmission jack.

8. Remove the torque converter retainer.

9.  **CAUTION:** Apply grease of the correct specification to the torque converter spigot.

With assistance, install the transmission.

- Clean the component mating faces.
- Tighten the bolts to 45 Nm (33 lb.ft).

10. Attach the flexplate to the torque converter.

- Rotate the crankshaft to access the bolts.
- Tighten the bolts to 45 Nm (33 lb.ft).

11. Attach the transmission breather pipe clip.

- Tighten the bolt to 25 Nm (18 lb.ft).

12. Attach the wiring harness.

- Tighten the Torx screws.
- Connect the electrical connector.

13. Attach the transmission fluid lines.

- Clean the components.
- Install the new O-ring seals.
- Secure with the clip.
- Tighten the bolt to 10 Nm (7 lb.ft).

14. Install the fuel pipe heat shield.

- Tighten the bolts to 10 Nm (7 lb.ft).
- Secure with the clips.

15. Install the transmission heat shield bracket.

16. Attach the selector cable.

17. Install the transmission case.

- Tighten the bolts to 10 Nm (7 lb.ft).

For additional information, refer to: [Transfer Case - V6 4.0L Petrol](#) (308-07B Transfer Case, Removal).

18. Adjust the selector cable.

For additional information, refer to: [Selector Lever Cable Adjustment](#) (307-05B Automatic Transmission/Transaxle External Controls - V6 4.0L Petrol, General Procedures).

19. Check and top-up the transmission fluid level.

For additional information, refer to: [Transmission Fluid Level Check](#) (307-01B Automatic Transmission/Transaxle - V6 4.0L Petrol, General Procedures).

20. Install the transmission heat shield.

- Tighten the bolts to 10 Nm (7 lb.ft).

21. NOTE: For NAS vehicles only.

If fitting new or exchange components, carry out long drive cycle.

For additional information, refer to: Powertrain Control Module (PCM) Long Drive Cycle Self-Test (303-14A, General Procedures).

Automatic Transmission/Transaxle - V6 4.0L Petrol/TDV6 2.7L Diesel - Diagnostics

Diagnosis and Testing

Principle of Operation

For a detailed description of the automatic transmission/transaxle system and operation, refer to the relevant Description and Operation sections in the workshop manual.

Fluid Level and Condition Check



CAUTION: The vehicle should not be driven if the fluid level is low as internal failure can result.

• **NOTE:** The transmission fluid temperature must not be allowed to exceed 50°C (122°F) whilst checking level. Should the temperature rise above this figure, abort the check and allow the transmission fluid to cool to below 30°C (86°F).

This vehicle is not equipped with a fluid level indicator. An incorrect level may affect the transmission operation and could result in transmission damage. To correctly check and add fluid to the transmission. Refer to the relevant section in the workshop manual.

High Fluid Level

A fluid level that is too high may cause the fluid to become aerated due to the churning action of the rotating internal parts. This will cause erratic control pressure, foaming, loss of fluid from the vent tube and possible transmission damage. If an overfill condition is identified, with the engine at idle ensure the fluid temperature is within the specified range and allow the excess fluid to drain until a small thread of fluid runs from the filler/level plug hole.

Low Fluid Level

A low fluid level could result in poor transmission engagement, slipping, or damage. This could also indicate a leak in one of the transmission seals or gaskets.

Adding Fluid



CAUTION: The use of any other type of transmission fluid other than that specified can result in transmission damage.

If fluid needs to be added, add fluid in 0.50 liter increments through the fill hole opening. Do not overfill the fluid. For fluid type, refer to the Specification section in the workshop manual.

Fluid Condition Check

1. **1.** Check the fluid level.
2. **2.** Observe the color and the odor of the fluid. The color under normal circumstances should be like honey, not dark brown or black.
3. **3.** Allow the fluid to drip onto a facial tissue and examine the stain.
4. **4.** If evidence of solid material is found, the transmission fluid pan should be removed for further inspection.

NOTE: In the event of a transmission unit replacement for internal failure, the oil cooler and pipes must also be replaced.

Inspection and Verification



CAUTION: Diagnosis by substitution from a donor vehicle is **NOT** acceptable. Substitution of control modules does not guarantee confirmation of a fault, and may also cause additional faults in the vehicle being tested and/or the donor vehicle.

1. **1.** Verify the customer concern.
2. **2.** Visually inspect for obvious signs of damage and system integrity.

Visual Inspection

Mechanical	Electrical	Hydraulic
<ul style="list-style-type: none"> ● Damaged/stuck shift mechanism ● Damaged automatic transmission casing 	<ul style="list-style-type: none"> ● Blown fuse(s) ● Damaged, loose or corroded connectors ● Wiring harness 	<ul style="list-style-type: none"> ● Fluid level too high/low ● Poor condition of fluid ● Fluid leak

3. **3.** If an obvious cause for an observed or reported concern is found, correct the cause (if possible) before proceeding to the next step.
4. **4.** If the cause is not visually evident check for Diagnostic Trouble Codes (DTCs) and refer to the DTC Index.

DTC Index

For a list of Diagnostic Trouble Codes (DTCs) that could be logged on this vehicle, please refer to Section 100-00.
REFER to: [Diagnostic Trouble Code \(DTC\) Index - DTC: Transmission Control Module \(TCM\) - Bosch](#) (100-00 General Information, Description and Operation).

Automatic Transmission/Transaxle - V6 4.0L Petrol/TDV6 2.7L Diesel - Input Shaft Seal

Removal and Installation

Removal

1.  **WARNING:** Do not work on or under a vehicle supported only by a jack. Always support the vehicle on safety stands.

Raise and support the vehicle.

2. Remove the transmission assembly.

Refer to: [Transmission](#) (307-01B Automatic Transmission/Transaxle - V6 4.0L Petrol, Removal and Installation).

Refer to: [Transmission](#) (307-01B Automatic Transmission/Transaxle - V6 4.0L Petrol, Removal and Installation).

Refer to: [Transmission](#) (307-01A Automatic Transmission/Transaxle - TDV6 2.7L Diesel, Removal and Installation).

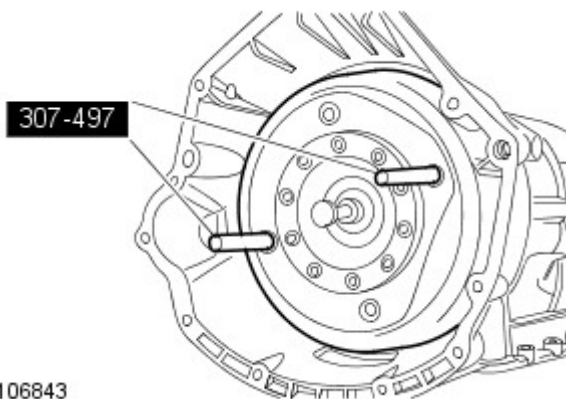

E106843

3.  **WARNING:** Do not let the torque converter drop out of the transmission. Failure to follow this instruction may result in personal injury.

Using the special tools, remove the torque converter. Drain any remaining fluid into a suitable container.

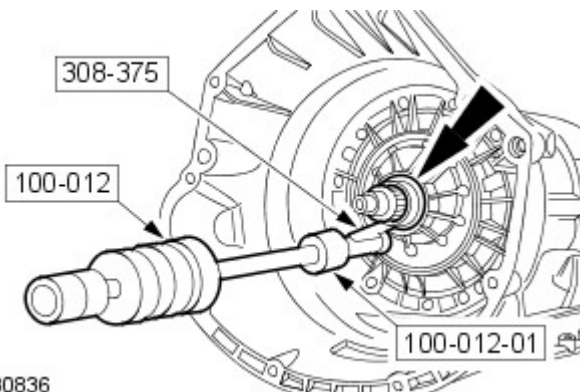

E30836

4.  **WARNING:** Make sure the transmission housing seal face is not damaged when removing the torque converter seal. Failure to follow this instruction may result in damage to the vehicle.

Using the special tools, remove the input shaft seal.

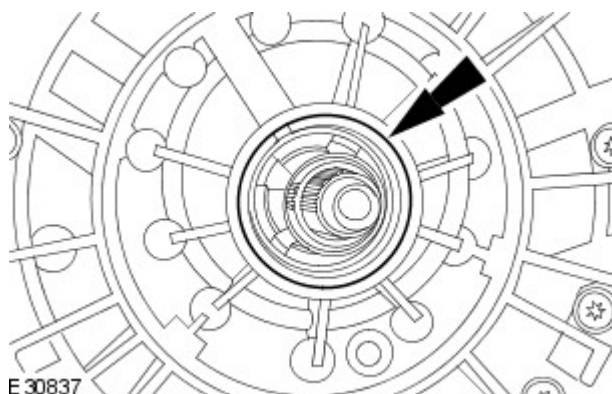

E 30837

5. **NOTE:** Using a suitable metal surface cleaner meeting Jaguar specification, clean the seal face on the housing before fitting the new seal.

Clean and inspect the transmission housing seal face.

Installation

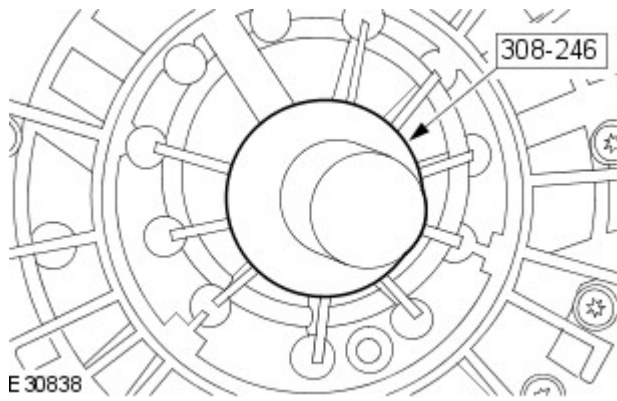

1. Using the special tool, install a new input shaft seal.

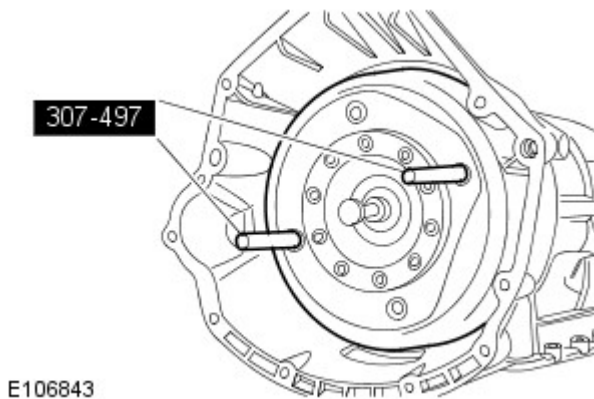

2.  **WARNING:** Do not let the torque converter drop out of the transmission. Failure to follow this instruction may result in personal injury.

- **NOTE:** The torque converter hub must engage fully in the oil pump drive gear.

Using the special tools, install the torque converter. Remove the special tools.

3. Install the transmission assembly.

Refer to: [Transmission](#) (307-01B Automatic Transmission/Transaxle - V6 4.0L Petrol, Removal and Installation).
Refer to: [Transmission](#) (307-01B Automatic Transmission/Transaxle - V6 4.0L Petrol, Removal and Installation).
Refer to: [Transmission](#) (307-01A Automatic Transmission/Transaxle - TDV6 2.7L Diesel, Removal and Installation).

Automatic Transmission/Transaxle - V8 5.0L Petrol/TDV6 3.0L Diesel -

Maintenance



CAUTION: Use only Shell M1375.4 Automatic transmission fluid. Use of any other fluids may result in a transmission malfunction or failure.

Description	Intervals
Normal maintenance	Filled for life.
Severe duty maintenance	Change the fluid at 48,000 km (30,000 miles) intervals.

Capacities

	Liters
Transmission	9.9

Lubricants, Fluids, Sealers and Adhesives

Description	Specification
Transmission fluid	Shell M1375.4
Sealant	WSS-M4G323-A6
Metal surface cleaner	WSW-M5B392-A
High temperature grease	Molecote FB180

Torque Specifications

- NOTE: A = refer to the procedure for correct torque sequence

Description	Nm	lb-ft	lb-in
Transmission retaining bolts	48	35	-
Transmission mount retaining bolts	60	44	-
Transmission fluid fill plug	A	A	A
Transmission control module (TCM) and main control valve body retaining bolts	8	-	53
Torque converter retaining bolts	62	46	-
Transmission fluid cooler tube retaining bolt	22	16	-
Transmission fluid drain plug	8	-	53
Transmission fluid pan, gasket and filter retaining bolts	8	-	53

Automatic Transmission/Transaxle - V8 5.0L Petrol/TDV6 3.0L Diesel - Transmission Description

Description and Operation

COMPONENT LOCATION

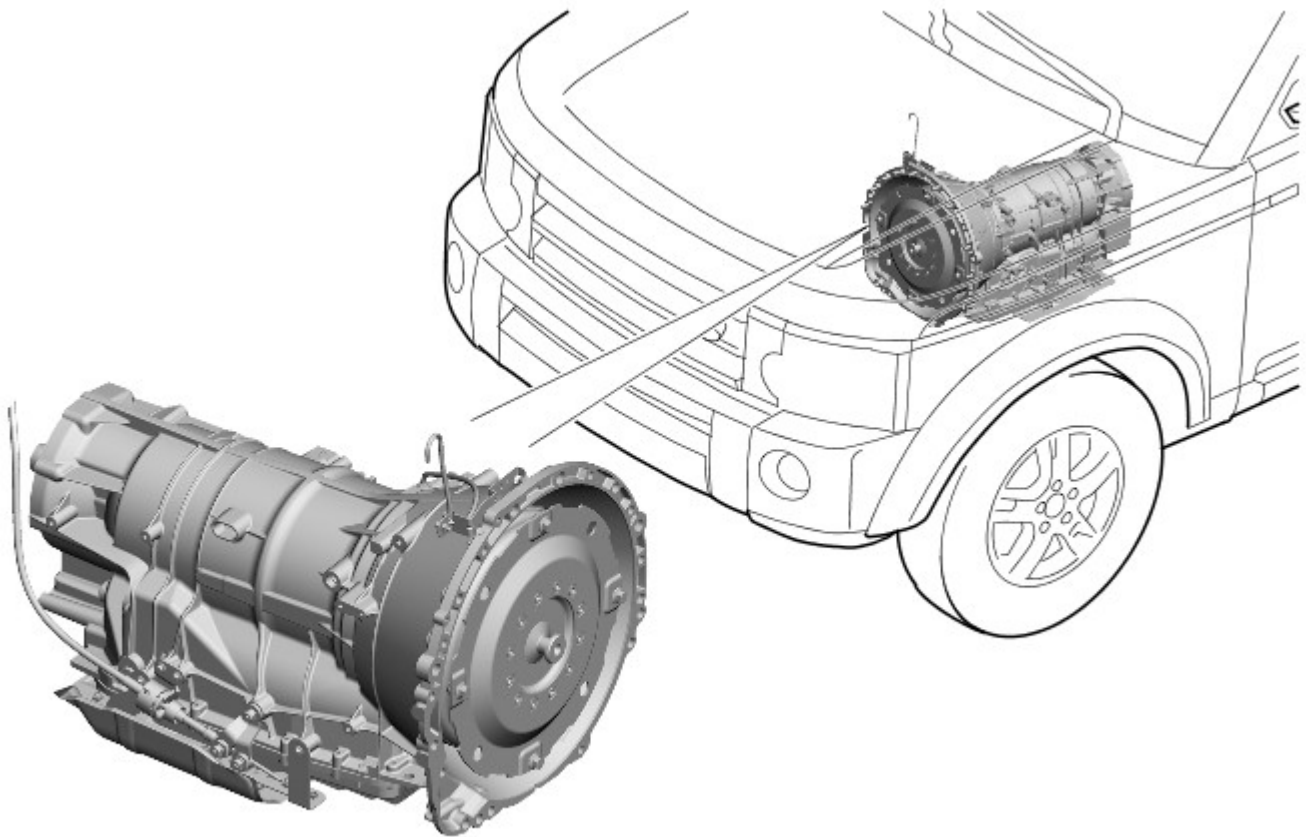

E122443

INTRODUCTION

The ZF 6HP28 transmission is an electronically controlled, hydraulically operated, six speed automatic unit. The hydraulic and electronic control elements of the transmission, including the [TCM \(transmission control module\)](#), are incorporated in a single unit located inside the transmission and is known as 'Mechatronic'.

3.0L diesel models use an updated derivative of the ZF 6HP28 transmission used in the 5.0L naturally aspirated models.

The ZF 6HP28 transmission has the following features:

- Designed to be maintenance free
- Transmission fluid is 'fill for life'
- The torque converter features a controlled slip feature with electronically regulated control of lock-up, creating a smooth transition to the fully locked condition
- Shift programs controlled by the [TCM](#)
- ASIS (adaptive shift strategy), to provide continuous adaptation of shift changes to suit the driving style of the driver, which can vary from sporting to economical
- Connected to the [ECM \(engine control module\)](#) via the high speed [CAN \(controller area network\)](#) bus for communications
- Default mode if major faults occur
- Diagnostics available from the [TCM](#) via the high speed [CAN](#) bus.

The transmission selections are made using the selector lever in the floor console and two paddle switches on the steering wheel.

For additional information, refer to: [External Controls](#) (307-05C Automatic Transmission/Transaxle External Controls - V8 5.0L Petrol/TDV6 3.0L Diesel, Description and Operation).

TRANSMISSION

The transmission comprises the main casing which houses all of the transmission components. The main casing also incorporates an integral bell housing.

A fluid pan is attached to the lower face of the main casing and is secured with bolts. The fluid pan is sealed to the main casing with a gasket. Removal of the fluid pan allows access to the Mechatronic valve block. The fluid pan has a magnet located around the drain plug which collects any metallic particles present in the transmission fluid.

A fluid filter is located inside the fluid pan. If the transmission fluid becomes contaminated or after any service work, the fluid pan with integral filter must be replaced.

On the [RH \(right-hand\)](#) side of the transmission, a gear change lever is installed on the end of a selector shaft. The selector shaft operates a selector spool valve and a selector switch in the transmission. A selector cable, connected between the gear change lever and the selector lever in the floor console, controls the position of the selector shaft.

The integral bell housing provides protection for the torque converter assembly and also provides the attachment for the gearbox to the engine. The torque converter is a non-serviceable assembly which also contains the lock-up clutch mechanism. The torque converter drives a crescent type pump via drive tangs. The fluid pump is located in the main casing, behind the torque converter.

The main casing contains the following major components:

- Input shaft
- Output shaft
- Mechatronic valve block which contains the solenoids, speed sensors and the [TCM](#)
- Three rotating multiplate drive clutches
- Two fixed multiplate brake clutches
- A single planetary gear train and a double planetary gear train.

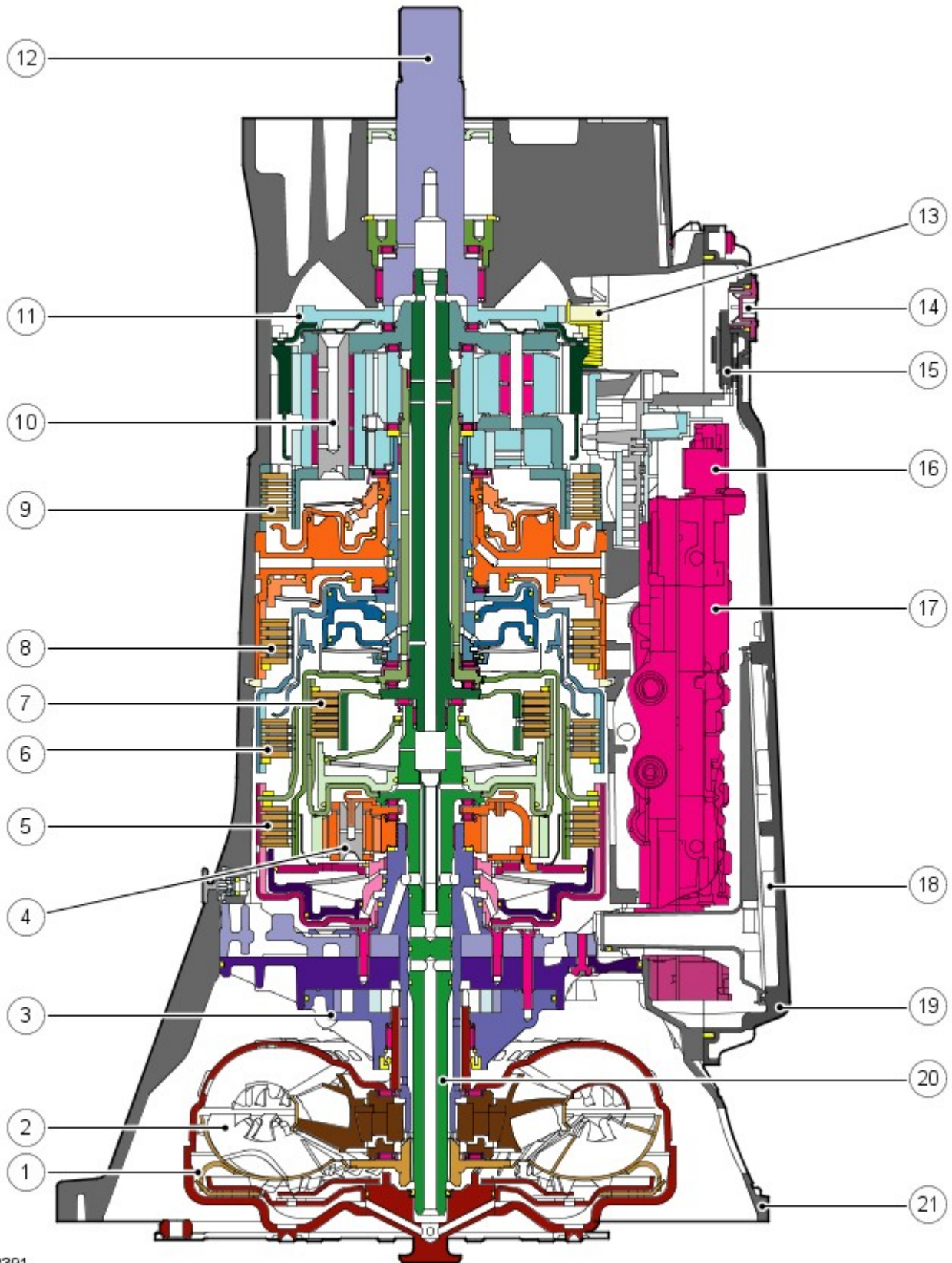

E42391

Item	Part Number	Description
1	-	Torque converter lock-up clutch
2	-	Torque converter
3	-	Fluid pump
4	-	Single planetary gearset
5	-	Clutch A
6	-	Clutch B
7	-	Clutch E
8	-	Brake C
9	-	Brake D
10	-	Double planetary gearset
11	-	Park lock gear

12	-	Output shaft
13	-	Park lock pawl
14	-	Drain plug
15	-	Magnet
16	-	Pressure regulator
17	-	Mechatronic valve block
18	-	Fluid filter
19	-	Fluid pan
20	-	Input shaft
21	-	Transmission casing

TORQUE CONVERTER

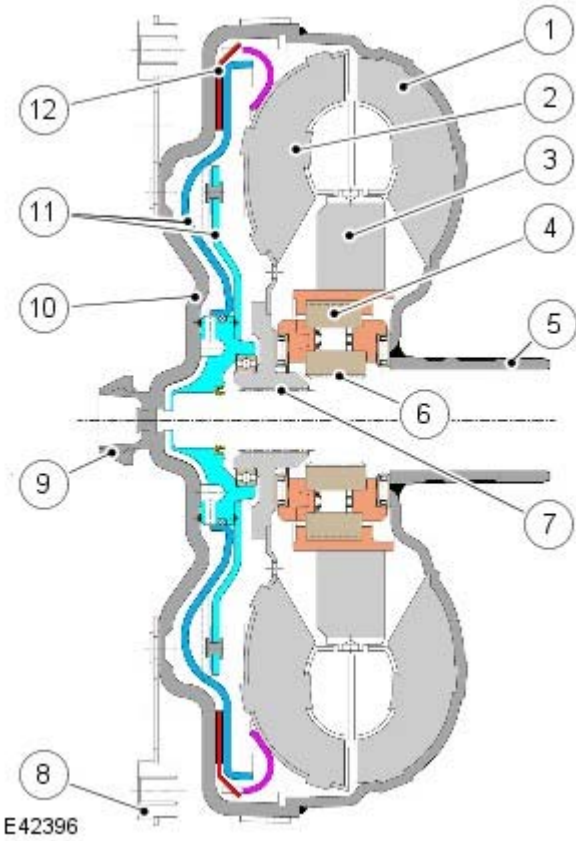

Item	Part Number	Description
1	-	Impeller
2	-	Turbine
3	-	Stator
4	-	Freewheel clutch
5	-	Torque converter hub
6	-	Stator shaft
7	-	Turbine shaft
8	-	Drive plate
9	-	Journal - Drive plate/crankshaft location
10	-	Torque converter cover
11	-	Lock-up clutch piston
12	-	Lock-up clutch plate

The torque converter is the coupling element between the engine and the transmission and is located in the bell housing, on the engine side of the transmission. The driven power from the engine crankshaft is transmitted hydraulically and mechanically through the torque converter to the transmission. The torque converter is connected to the engine by a drive plate attached to the rear of the crankshaft.

The torque converter comprises an impeller, a stator and a turbine. The torque converter is a sealed unit with all components located between the converter housing cover and the impeller. The two components are welded together to form a sealed, fluid filled housing. With the impeller welded to the converter housing cover, the impeller is therefore driven at engine crankshaft speed.

The converter housing cover has four threaded bosses, which provide for attachment of the engine drive plate. The threaded bosses also provide for location of special tools which are required to remove the torque converter from the bell housing.

Impeller

Fluid Flow

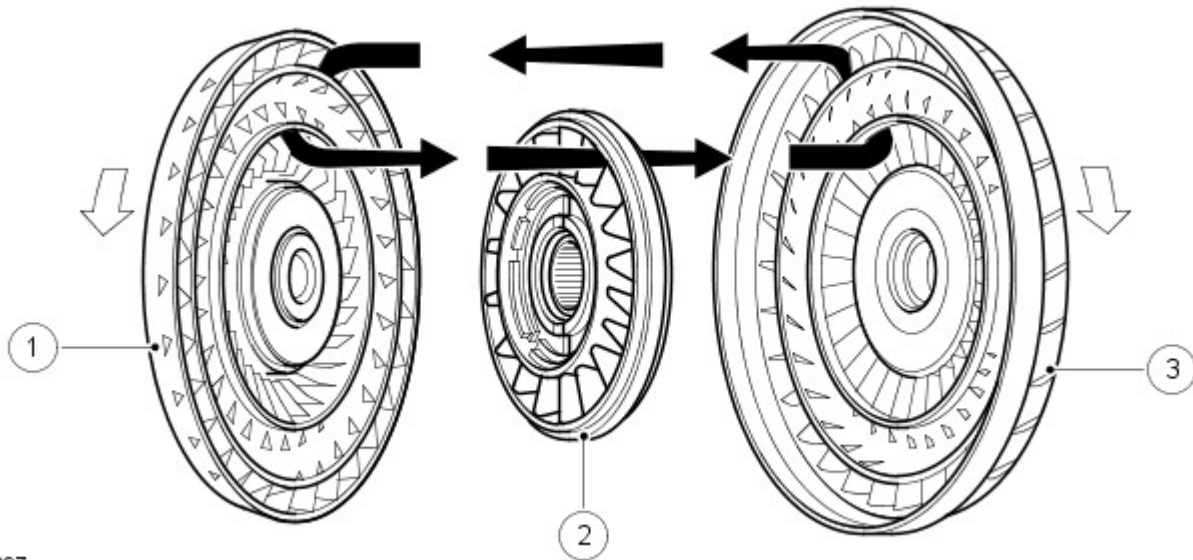

E42397

Item	Part Number	Description
1	-	Turbine
2	-	Stator
3	-	Impeller

When the engine is running the rotating impeller acts as a centrifugal pump, picking up fluid at its center and discharging it at high velocity through the blades on its outer rim. The design and shape of the blades and the curve of the impeller body cause the fluid to rotate in a clockwise direction as it leaves the impeller. This rotation improves the efficiency of the fluid as it contacts the outer row of blades on the turbine.

The centrifugal force of the fluid leaving the blades of the impeller is passed to the curved inner surface of the turbine via the tip of the blades. The velocity and clockwise rotation of the fluid causes the turbine to rotate.

Turbine

The turbine is similar in design to the impeller with a continuous row of blades. Fluid from the impeller enters the turbine through the tip of the blades and is directed around the curved body of the turbine to the root of the blades. The curved surface redirects the fluid back in the opposite direction to which it entered the turbine, effectively increasing the turning force applied to the turbine from the impeller. This principle is known as torque multiplication.

When engine speed increases, turbine speed also increases. The fluid leaving the inner row of the turbine blades is rotated in a counter-clockwise direction due to the curve of the turbine and the shape of the blades. The fluid is now flowing in the opposite direction to the engine rotation and therefore the impeller. If the fluid was allowed to hit the impeller in this condition, it would have the effect of applying a brake to the impeller, eliminating the torque multiplication effect. To prevent this, the stator is located between the impeller and the turbine.

Stator

The stator is located on the splined transmission input shaft via a freewheel clutch. The stator comprises a number of blades which are aligned in an opposite direction to those of the impeller and turbine. The main function of the stator is to redirect the returning fluid from the turbine, changing its direction to that of the impeller.

The redirected fluid from the stator is directed at the inner row of blades of the impeller, assisting the engine in turning the impeller. This sequence increases the force of the fluid emitted from the impeller and thereby increases the torque multiplication effect of the torque converter.

Stator Functions

- NOTE: The following illustration shows a typical stator

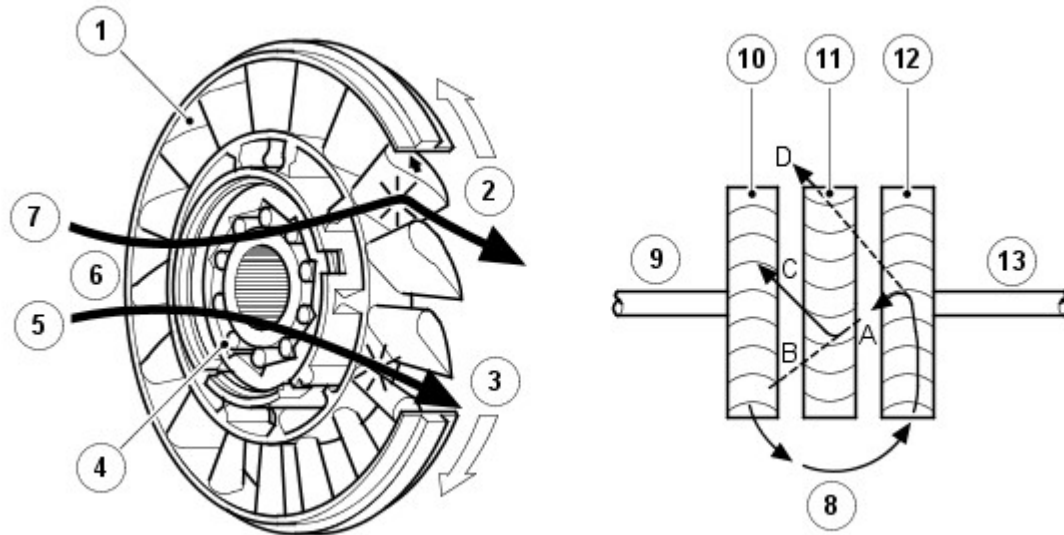

E 42398

Item	Part Number	Description
1	-	Blades
2	-	Stator held – fluid flow redirected
3	-	Stator rotates freely
4	-	Roller
5	-	Converter at coupling speed
6	-	Fluid flow from turbine
7	-	Converter multiplying
8	-	Fluid flow from impeller
9	-	Drive from engine
10	-	Impeller
11	-	Stator
12	-	Turbine
13	-	Output to transmission

Fluid emitted from the impeller acts on the turbine. If the turbine is rotating at a slower speed than the fluid from the impeller, the fluid will be deflected by the turbine blades in the path 'A'. The fluid is directed at and deflected by the stator blades from path 'B' to path 'C'. This ensures that the fluid is directed back to the pump in the optimum direction. In this condition the sprag clutch is engaged and the force of the fluid on the stator blades assists the engine in rotating the impeller.

As the rotational speed of the engine and therefore the turbine increases, the direction of the fluid leaving the turbine changes to path 'D'. The fluid is now directed from the turbine to the opposite side of the stator blades, rotating the stator in the opposite direction. To prevent the stator from resisting the smooth flow of the fluid from the turbine, the sprag clutch releases, allowing the stator to rotate freely on its shaft.

When the stator becomes inactive, the torque converter no longer multiplies the engine torque. When the torque converter reaches this operational condition it ceases to multiply the engine torque and acts solely as a fluid coupling, with the impeller and the turbine rotating at approximately the same speed.

The stator uses a sprag type, one way, freewheel clutch. When the stator is rotated in a clockwise direction the sprags twist and are wedged between the inner and outer races. In this condition the sprags transfer the rotation of the outer race to the inner race which rotates at the same speed.

One Way Free Wheel Clutch – Typical

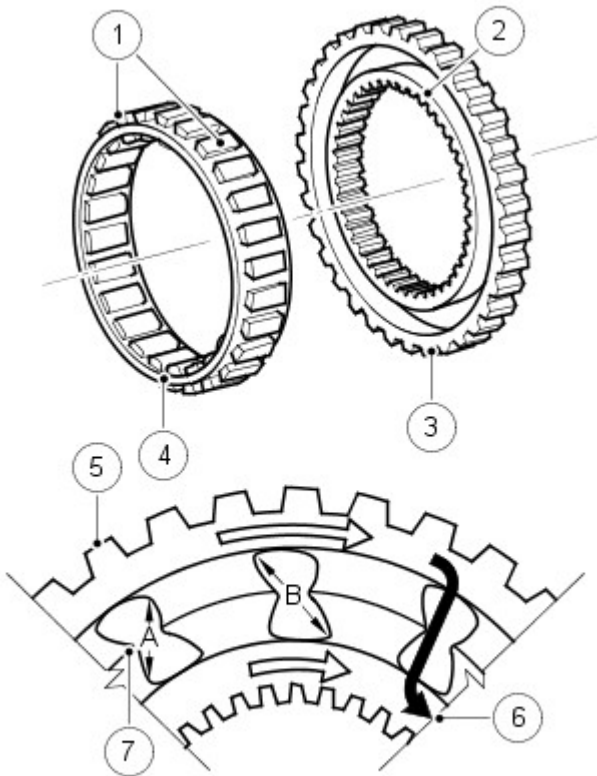

E 42712

Item	Part Number	Description
1	-	Sprags
2	-	Inner race
3	-	Outer race
4	-	Sprag and cage assembly
5	-	Sprag outer race
6	-	Sprag inner race
7	-	Retaining ring

The free wheel clutch can perform three functions; hold the stator stationary, drive the stator and free wheel allowing the stator to rotate without a drive output. The free wheel clutch used in the ZF 6HP28 transmission is of the sprag type and comprises an inner and outer race and a sprag and cage assembly. The inner and outer races are pressed into their related components with which they rotate. The sprag and cage assembly is located between the inner and outer races.

The sprags are located in a cage which is a spring which holds the sprags in the 'wedge' direction and maintains them in contact with the inner and outer races.

Referring to the illustration, the sprags are designed so that the dimension 'B' is larger than the distance between the inner and outer race bearing surfaces. When the outer race rotates in a clockwise direction, the sprags twist and the edges across the dimension 'B' wedge between the races, providing a positive drive through each sprag to the inner race. The dimension 'A' is smaller than the distance between the inner and outer race bearing surfaces. When the outer race rotates in an anti-clockwise direction, the dimension 'A' is too small to allow the sprags to wedge between the races, allowing the outer race to rotate freely.

On the illustration shown, when the outer race is rotated in a clockwise direction, the sprags twist and are 'wedged' between the inner and outer races. The sprags then transfer the rotation of the outer race to the inner race, which rotates at the same speed.

Lock-Up Clutch Mechanism

The [TCC \(torque converter clutch\)](#) is hydraulically controlled by an EPRS (electronic pressure regulating solenoid), which is controlled by the [TCM](#). This allows the torque converter to have three states of operation as follows:

- Fully engaged
- Controlled slip variable engagement
- Fully disengaged.

The [TCC](#) is controlled by two hydraulic spool valves located in the valve block. These valves are actuated by pilot pressure supplied via a solenoid valve which is also located in the valve block. The solenoid valve is operated by [PWM \(pulse width modulation\)](#) signals from the [TCM](#) to give full, partial or no lock-up of the torque converter.

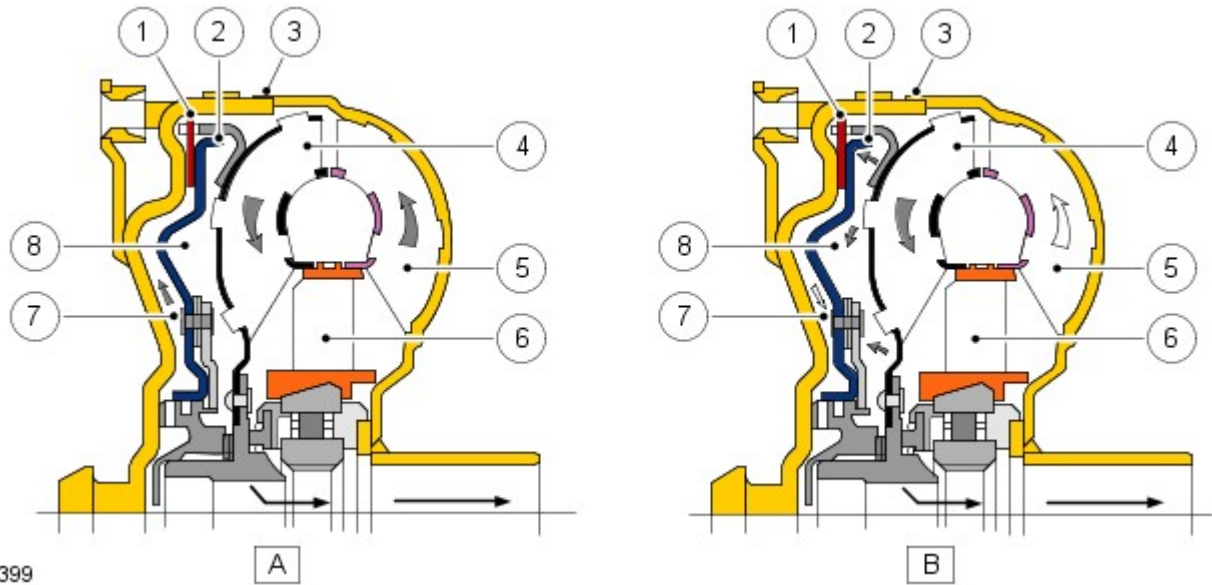

E 42399

Item	Part Number	Description
A	-	Unlocked condition
B	-	Locked condition
1	-	Clutch plate
2	-	Clutch piston
3	-	Torque converter body
4	-	Turbine
5	-	Impeller
6	-	Stator
7	-	Piston chamber
8	-	Turbine chamber

The lock-up clutch is a hydro-mechanical device which eliminates torque converter slip, improving fuel consumption. The engagement and disengagement is controlled by the [TCM](#) to allow a certain amount of controlled 'slip'. This allows a small difference in the rotational speeds of the impeller and the turbine which results in improved shift quality. The lock-up clutch comprises a piston and a clutch friction plate.

In the unlocked condition, the oil pressure supplied to the piston chamber and the turbine chamber is equal. Pressurized fluid flows through a drilling in the turbine shaft and through the piston chamber to the turbine chamber. In this condition the clutch plate is held away from the torque converter body and torque converter slip is permitted.

In the locked condition, the [TCC](#) spool valves are actuated by the EPRS. The fluid flow in the unlocked condition is reversed and the piston chamber is vented. Pressurized fluid is directed into the turbine chamber and is applied to the clutch piston. The piston moves with the pressure and pushes the clutch plate against the torque converter body. As the pressure increases, the friction between the clutch plate and the body increases, finally resulting in full lock-up of the clutch plate with the body. In this condition there is direct mechanical drive from the engine crankshaft to the transmission planetary gear train.

FLUID PUMP

The fluid pump is an integral part of the transmission. The fluid pump is used to supply hydraulic pressure for the operation of the control valves and clutches, to pass the fluid through the transmission cooler and to lubricate the gears and shafts.

The ZF 6HP28 fluid pump is a crescent type pump and is located between the intermediate plate and the torque converter. The pump has a delivery rate of 16 cm³ per revolution.

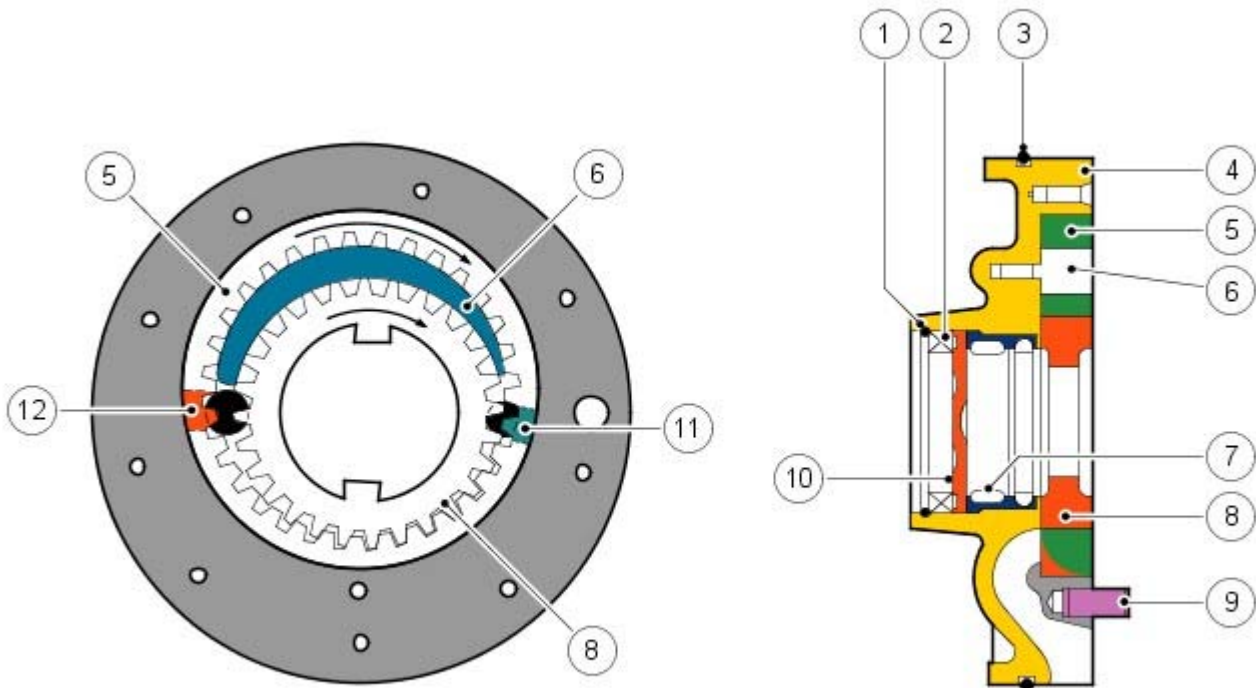

E42400

Item	Part Number	Description
1	-	Securing ring
2	-	Shaft oil seal
3	-	O-ring seal
4	-	Pump housing
5	-	Ring gear
6	-	Crescent spacer
7	-	Roller bearing
8	-	Impeller
9	-	Centering pin
10	-	Spring washer
11	-	Outlet port (high pressure)
12	-	Inlet port (low pressure)

The pump comprises a housing, a crescent spacer, an impeller and a ring gear. The housing has inlet and outlet ports to direct flow and is located in the intermediate plate by a centering pin. The pump action is achieved by the impeller, ring gear and crescent spacer.

The crescent spacer is fixed in its position by a pin and is located between the ring gear and the impeller. The impeller is driven by drive from the torque converter hub which is located on a needle roller bearing in the pump housing. The impeller teeth mesh with those of the ring gear. When the impeller is rotated, the motion is transferred to the ring gear which rotates in the same direction.

The rotational motion of the ring gear and the impeller collects fluid from the intake port in the spaces between the teeth. When the teeth reach the crescent spacer, the oil is trapped in the spaces between the teeth and is carried with the rotation of the gears. The spacer tapers near the outlet port. This reduces the space between the gear teeth causing a build up of fluid pressure as the oil reaches the outlet port. When the teeth pass the end of the spacer the pressurized fluid is released into the outlet port.

The fluid emerging from the outlet port is passed through the fluid pressure control valve. At high operating speeds the pressure control valve maintains the output pressure to the gearbox at a predetermined maximum level. Excess fluid is relieved from the pressure control valve and is directed, via the main pressure valve in the valve block, back to the pump inlet port. This provides a pressurized feed to the pump inlet which prevents cavitation and reduces pump noise.

MECHATRONIC VALVE BLOCK

The Mechatronic valve block is located in the bottom of the transmission and is covered by the fluid pan. The valve block houses the [TCM](#), electrical actuators, speed sensors and control valves which provide all electro-hydraulic control for all transmission functions. The Mechatronic valve block comprises the following components:

- [TCM](#)
- Six pressure regulator solenoids
- One shift control solenoid
- One damper
- Twenty one hydraulic spool valves
- Manually operated selector valve
- Temperature sensor

- Turbine speed sensor
- Output shaft speed sensor.

Mechatronic Valve Block

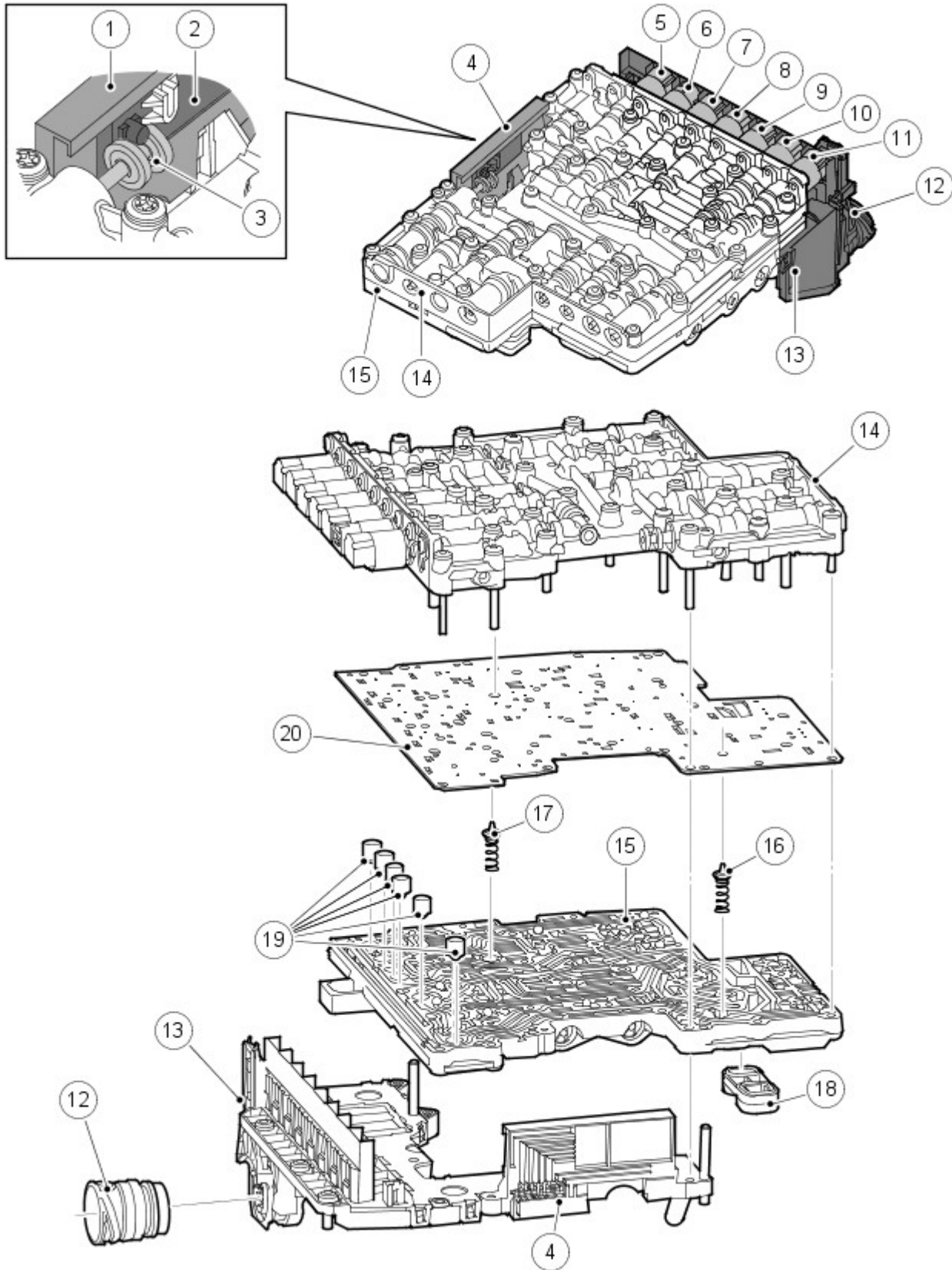

E42392

Item	Part Number	Description
1	-	Position switch
2	-	Sliding block
3	-	Selector spool valve
4	-	Position switch assembly
5	-	EPRS 6
6	-	Solenoid Valve 1
7	-	EPRS 4

8	-	EPRS 5
9	-	EPRS 3
10	-	EPRS 2
11	-	EPRS 1
12	-	Electrical connector
13	-	TCM
14	-	Valve housing
15	-	Valve plate
16	-	Torque converter retaining valve
17	-	Clutch return valve
18	-	Element seal
19	-	Pressure regulator dampers
20	-	Intermediate plate

Valve Housing Components

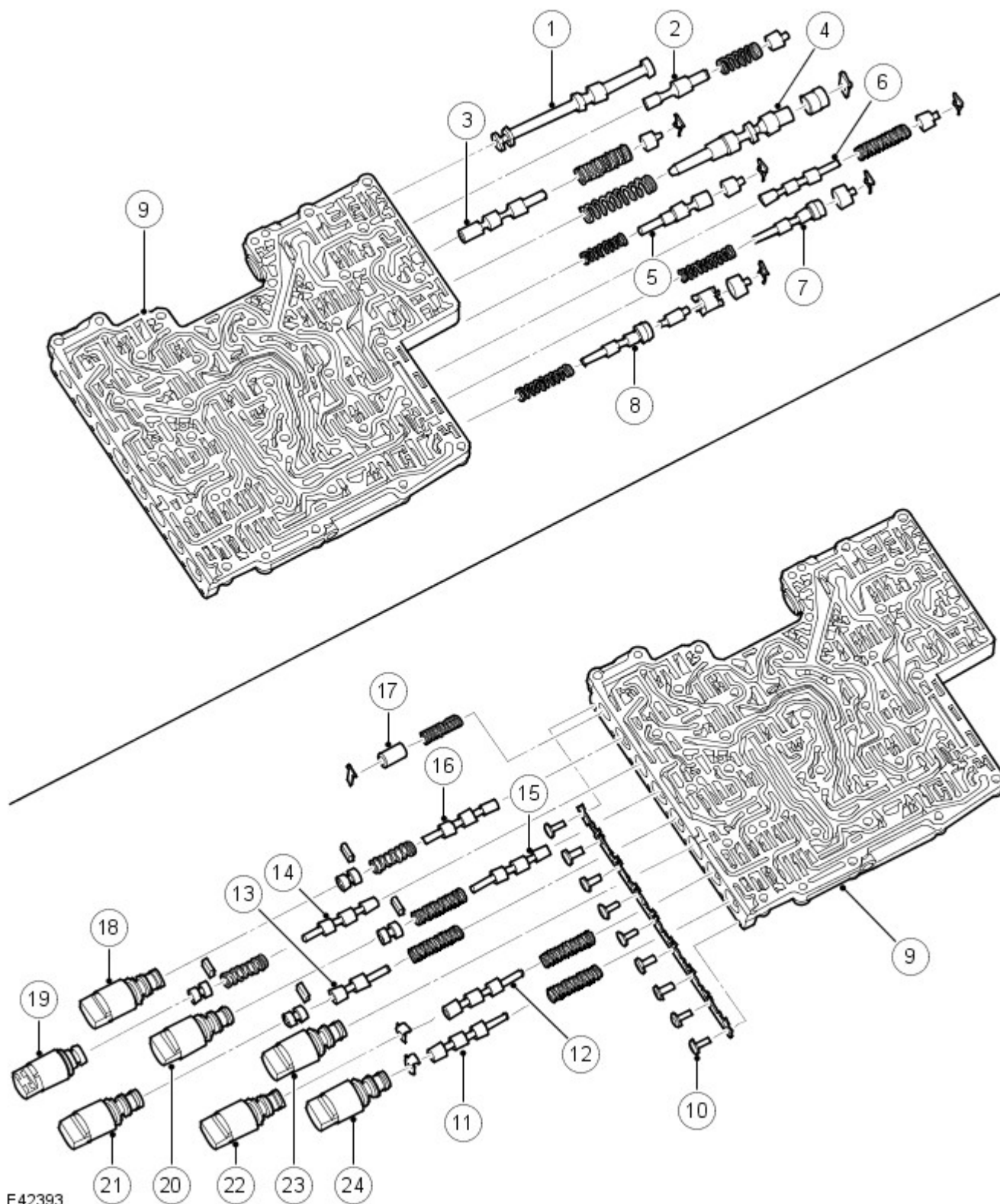

E42393

Item	Part Number	Description
1	-	Selector spool valve
2	-	Lubricating valve
3	-	Torque converter pressure valve
4	-	System pressure valve
5	-	Torque converter clutch valve
6	-	Retaining valve - Clutch E
7	-	Clutch valve E
8	-	Clutch valve A
9	-	Valve housing
10	-	Bolts
11	-	Retaining valve - Clutch A

12	-	Retaining valve – Clutch B
13	-	Pressure reducing valve
14	-	Shift valve 1
15	-	Retaining valve – Brake D
16	-	Shift valve 2
17	-	Damper
18	-	EPRS 6
19	-	Solenoid valve 1
20	-	EPRS 4
21	-	EPRS 5
22	-	EPRS 2
23	-	EPRS 3
24	-	EPRS 1

Valve Plate Components

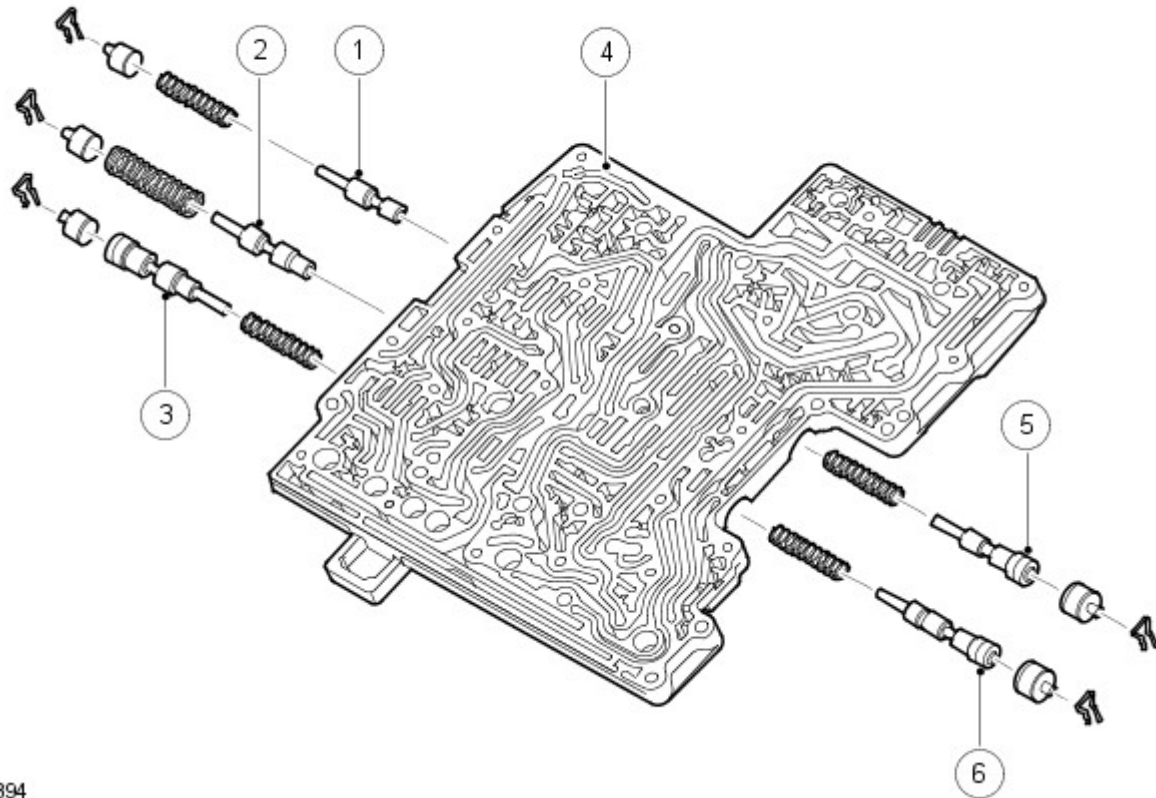

E42394

Item	Part Number	Description
1	-	Retaining valve – Brake D2
2	-	Clutch valve – Brake D2
3	-	Clutch valve B
4	-	Valve plate
5	-	Clutch valve – Brake D1
6	-	Clutch valve – Brake C

Electronic Pressure Regulator Solenoids

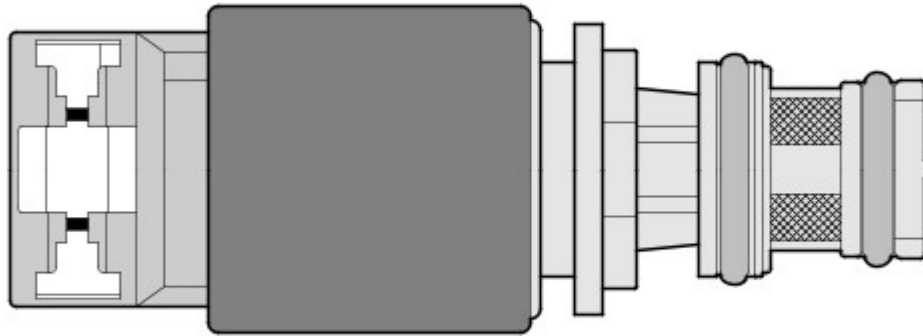

E42713

Six EPRS are located in the valve block. The solenoids are controlled by [PWM](#) signals from the [TCM](#). The solenoids convert the electrical signals into hydraulic control pressure proportional to the signal to actuate the spool valves for precise transmission operation.

The following table shows EPRS and their associated functions:

EPRS	Function
1	Clutch A
2	Clutch B
3	Clutch C
4	Brake clutches D and E
5	System pressure control
6	Torque converter lock-up control

Solenoids EPRS 1, 3 and 6 supply a lower control pressure as the signal amperage increases and can be identified by a black connector cap. The [TCM](#) operates the solenoids using PWM signals. The TCM monitors engine load and clutch slip and varies the solenoid duty cycle accordingly. The solenoids have a 12 V operating voltage and a pressure range of 0 - 4.6 bar (0 - 67 lbf.in²).

Solenoids EPRS 2, 4 and 5 supply a higher control pressure as the signal amperage increases and can be identified by a green connector cap. The solenoids are normally open, regulating flow solenoid valves. The operates the solenoids using a [PWM](#) earth proportional to the required increasing or decreasing clutch pressures. The solenoids have a 12 V operating voltage and a pressure range of 4.6 - 0 bar (67 - 0 lbf.in²).

The resistance of the solenoid coil winding for solenoid is between 26 to 30.4 ohms at 20 °C (68 °F).

Control Solenoid

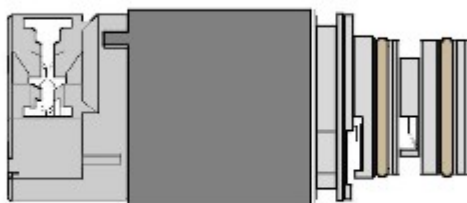

E42714

A shift control SV (solenoid valve) is located in the valve block. The solenoid is controlled by the [TCM](#) and converts electrical signals into hydraulic control signals to control clutch application.

The shift control solenoid is an open/closed, on/off solenoid which is controlled by the [TCM](#) switching the solenoid to earth. The [TCM](#) also supplies power to the solenoid. The [TCM](#) energizes the solenoid in a programmed sequence for clutch application for gear ratio changes and shift control.

The resistance of the solenoid coil winding for solenoid is between 26 to 30.4 ohms at 20 °C (68 °F).

Sensors

Speed Sensors

The turbine speed sensor and the output shaft speed sensor are Hall effect type sensors located in the Mechatronic valve block and are not serviceable items. The [TCM](#) monitors the signals from each sensor to determine the input (turbine) speed and the output shaft speed.

The turbine speed is monitored by the [TCM](#) to calculate the slip of the torque converter clutch and internal clutch slip. This signal allows the [TCM](#) to accurately control the slip timing during shifts and adjust clutch application or release pressure for overlap shift control.

The output shaft speed is monitored by the [TCM](#) and compared to engine speed signals received on the [CAN](#) bus from the [ECM](#). Using a comparison of the two signals the [TCM](#) calculates the transmission slip ratio for plausibility and maintains adaptive pressure control.

Temperature Sensor

The temperature sensor is also located in the Mechatronic valve block. The [TCM](#) uses the temperature sensor signals to determine the temperature of the transmission fluid. These signals are used by the [TCM](#) to control the transmission operation to promote faster warm-up in cold conditions or to assist with fluid cooling by controlling the transmission operation when high fluid temperatures are experienced. If the sensor fails, the [TCM](#) will use a default value and a fault code will be stored in the [TCM](#).

Damper

There is 1 damper located in the valve housing. The damper is used to regulate and dampen the regulated pressure supplied via EPRS 5. The damper is load dependent through modulation of the damper against return spring pressure.

The damper comprises a piston, a housing bore and a spring. The piston is subject to the pressure applied by the spring. The bore has a connecting port to the function to which it applies. Fluid pressure applied to the applicable component (i.e. a clutch) is also subjected to the full area of the piston, which moves against the opposing force applied by the spring. The movement of the piston creates an action similar to a shock absorber, momentarily delaying the build up of pressure in the circuit. This results in a more gradual application of clutches improving shift quality.

Spool Valves

The valve block contains 21 spool valves which control various functions of the transmission. The spool valves are of conventional design and are operated by fluid pressure.

Each spool valve is located in its spool bore and held in a default (unpressurized) position by a spring. The spool bore has a number of ports which allow fluid to flow to other valves and clutches to enable transmission operation. Each spool has a piston which is waisted to allow fluid to be diverted into the applicable ports when the valve is operated.

When fluid pressure moves a spool, 1 or more ports in the spool bore are covered or uncovered. Fluid is prevented from flowing or is allowed to flow around the applicable waisted area of the spool and into another uncovered port. The fluid is either passed through galleries to actuate another spool, operate a clutch or is returned to the fluid pan.

DRIVE CLUTCHES

Multiplate Drive or Brake Clutch – Typical

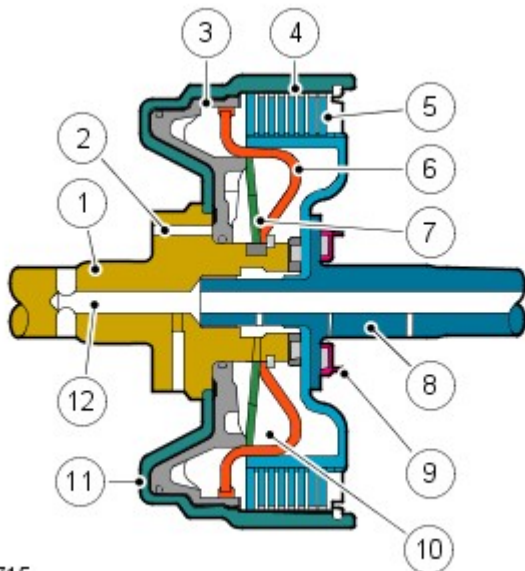

E42715

Item	Part Number	Description
1	-	Input shaft
2	-	Main pressure supply port
3	-	Piston
4	-	Cylinder – external plate carrier
5	-	Clutch plate assembly
6	-	Baffle plate
7	-	Diaphragm spring
8	-	Output shaft
9	-	Bearing

10	-	Dynamic pressure equalization chamber
11	-	Piston chamber
12	-	Lubrication channel

There are three drive clutches and two brake clutches used in the ZF 6HP28 transmission. Each clutch comprises one or more friction plates dependent on the output controlled. A typical clutch consists of a number of steel outer plates and inner plates with friction material bonded to each face.

On 3.0L diesel models, the updated transmission includes additional clutch plates to enable the transmission to manage the additional power output from these engines.

The clutch plates are held apart mechanically by a diaphragm spring and hydraulically by dynamic pressure. The pressure is derived from a lubrication channel which supplies fluid to the bearings etc. The fluid is passed via a drilling in the output shaft into the chamber between the baffle plate and the piston. To prevent inadvertent clutch application due to pressure build up produced by centrifugal force, the fluid in the dynamic pressure equalization chamber overcomes any pressure in the piston chamber and holds the piston off the clutch plate assembly.

When clutch application is required, main pressure from the fluid pump is applied to the piston chamber from the supply port. This main pressure overcomes the low pressure fluid present in the dynamic pressure equalization chamber. The piston moves, against the pressure applied by the diaphragm spring, and compresses the clutch plate assembly. When the main pressure falls, the diaphragm spring pushes the piston away from the clutch plate assembly, disengaging the clutch.

PLANETARY GEAR TRAINS

The planetary gear trains used on the ZF 6HP28 transmission comprise a single web planetary gear train and a double web planetary gear train. These gear trains are known as Lepelletier type gear trains and together produce the six forward gears and the one reverse gear.

Single Web Planetary Gear Train

The single web planetary gear train comprises:

- Sunwheel
- Four planetary gears
- Planetary gear carrier (spider)
- Ring gear or annulus.

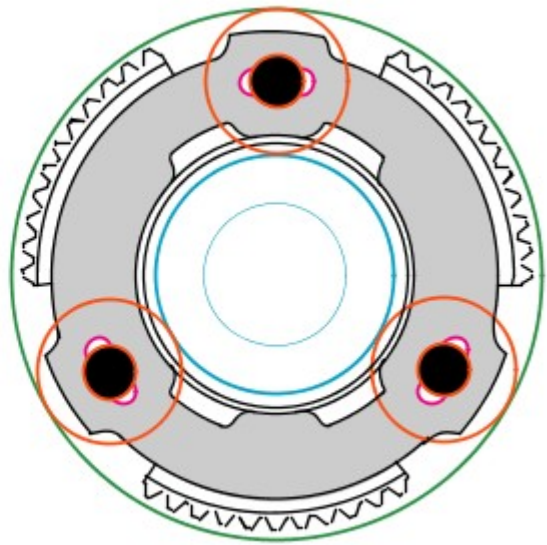
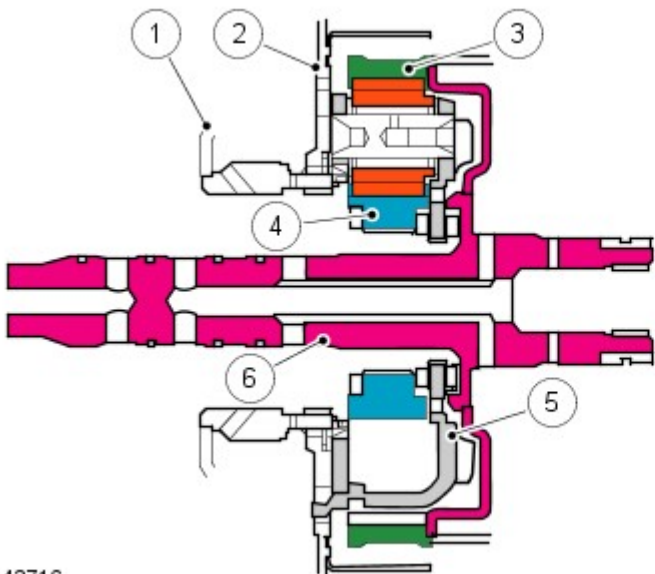

E42716

Item	Part Number	Description
1	-	Cylinder
2	-	Baffle plate
3	-	Ring gear
4	-	Sun gear
5	-	Planetary gear spider
6	-	Torque converter input shaft

Torque Converter Input Shaft

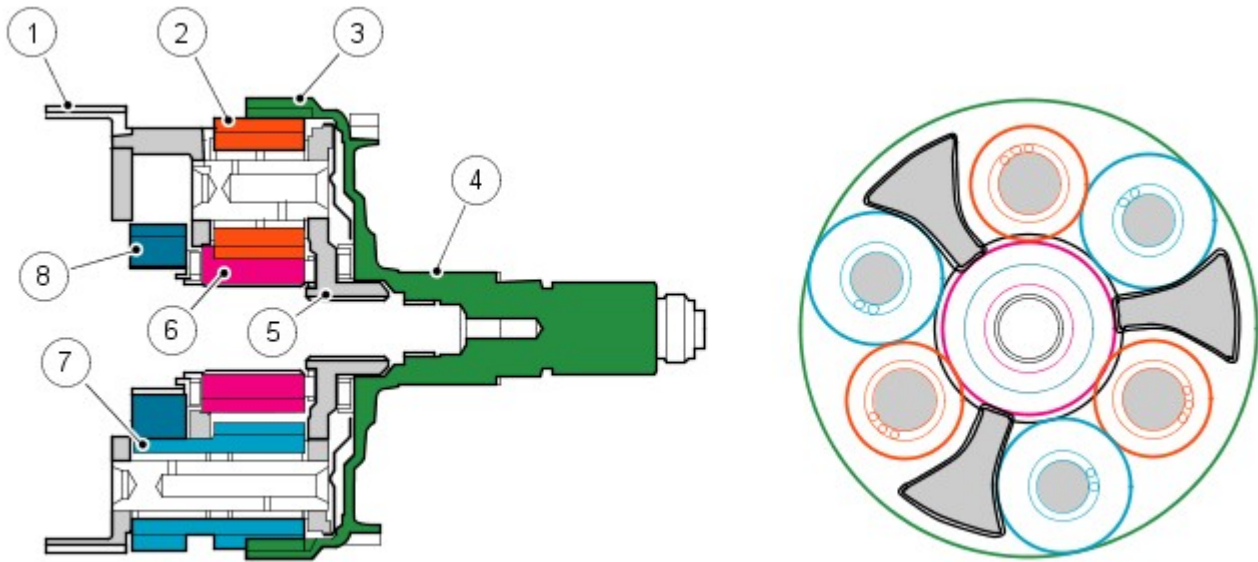

E42717

Item	Part Number	Description
1	-	Planetary gear spider
2	-	Planetary gears (short)
3	-	Ring gear
4	-	Output shaft
5	-	Planetary gear carrier
6	-	Sunwheel
7	-	Double planetary gears (long)
8	-	Sunwheel

The double planetary gear train comprises:

- Two sunwheels
- Three short planetary gears
- Three long planetary gears
- Planetary gear carrier
- Ring gear or annulus

TRANSMISSION CONTROL MODULE

The [TCM](#) is an integral part of the Mechatronic valve block which is located at the bottom of the transmission, within the fluid pan. The [TCM](#) is the main controlling component of the transmission.

The [TCM](#) processes signals from the transmission speed and temperature sensors, [ECM](#) and other vehicle systems. From the received signal inputs and pre-programmed data, the module calculates the correct gear, torque converter clutch setting and optimum pressure settings for gear shift and lock-up clutch control.

CONTROL DIAGRAM

- NOTE: A = Hardwired; B = K bus; D = High speed [CAN](#) bus O = LIN (local interconnect network) bus.

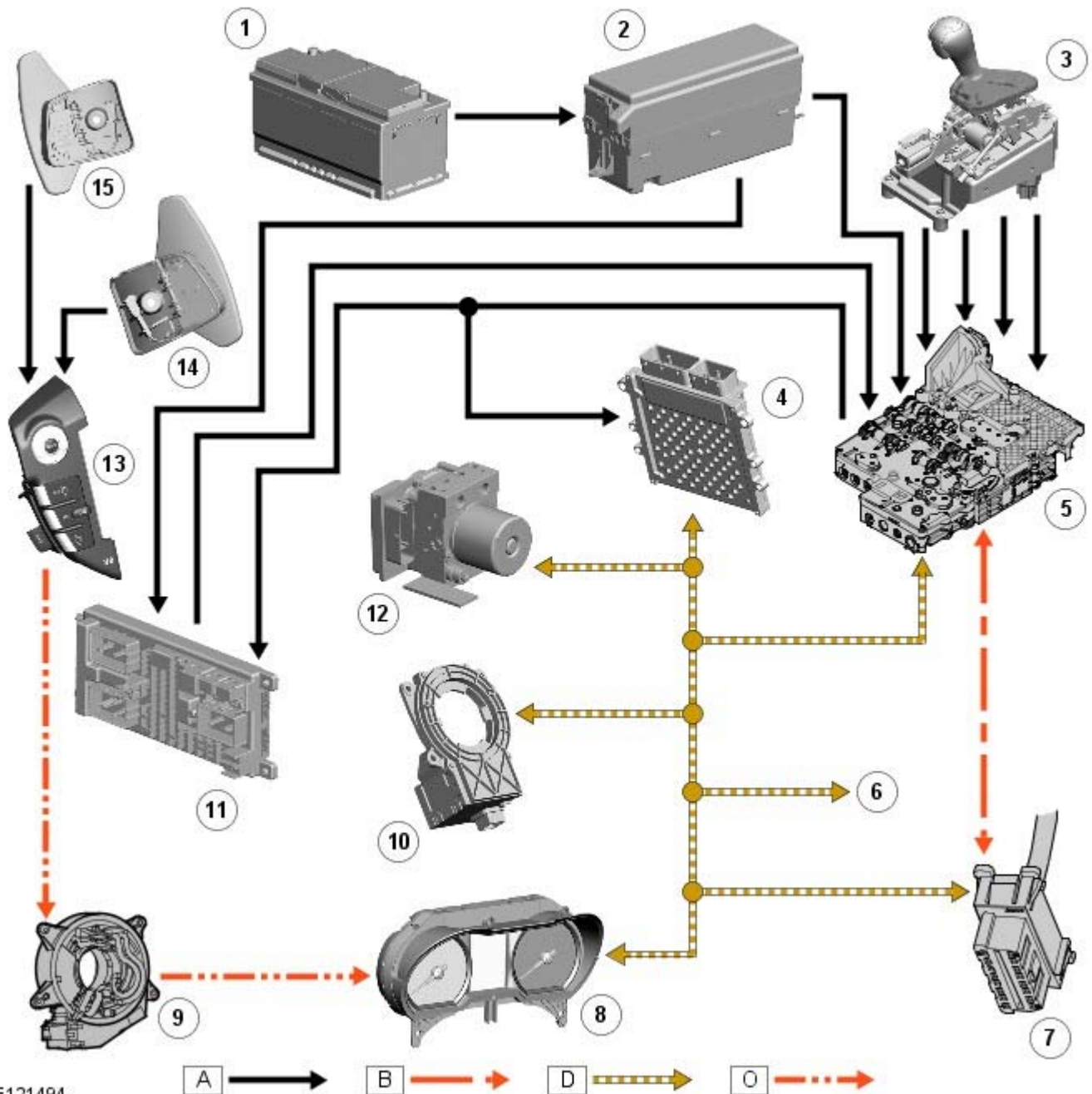

E121494



Item	Part Number	Description
1	-	Battery
2	-	EJB (engine junction box)
3	-	Selector lever
4	-	ECM (engine control module)
5	-	TCM
6	-	To other systems
7	-	Diagnostic socket
8	-	Instrument cluster
9	-	Clockspring
10	-	Steering angle sensor
11	-	CJB (central junction box)
12	-	ABS module
13	-	Steering wheel LH switchpack
14	-	Upshift paddle switch
15	-	Downshift paddle switch

OPERATION

Power Flows

Operation of the transmission is controlled by the [TCM](#), which electrically activates various solenoids to control the transmission gear selection. The sequence of solenoid activation is based on programmed information in the [TCM](#) memory and physical transmission operating conditions such as vehicle speed, throttle position, engine load and selector lever position.

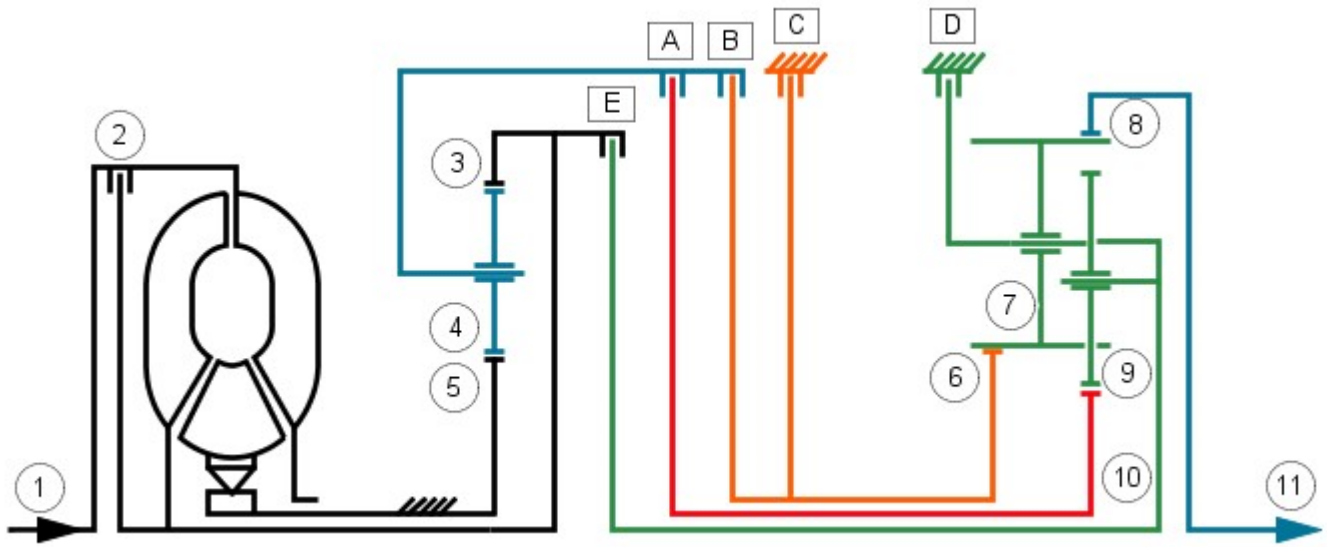

E42718

Item	Part Number	Description
1	-	Torque input from engine
2	-	Torque converter lock-up clutch
3	-	Single web planetary gear carrier
4	-	Single web planetary gears
5	-	Single web sunwheel 1
6	-	Double web sunwheel 2
7	-	Double web planetary gears - long
8	-	Double web planetary gear carrier
9	-	Double web planetary gears - short
10	-	Double web sunwheel 3
11	-	Torque output from transmission
A	-	Multiplate clutch
B	-	Multiplate clutch
C	-	Multiplate brake
D	-	Multiplate brake
E	-	Multiplate clutch

Engine torque is transferred, via operation of single or combinations of clutches to the 2 planetary gear trains. Both gear trains are controlled by reactionary inputs from brake clutches to produce the 6 forward gears and 1 reverse gear. The ratios are as follows:

Gear	1st	2nd	3rd	4th	5th	6th	Reverse
Ratio	4.171	2.340	1.521	1.143	0.867	0.691	3.403

Shift Elements

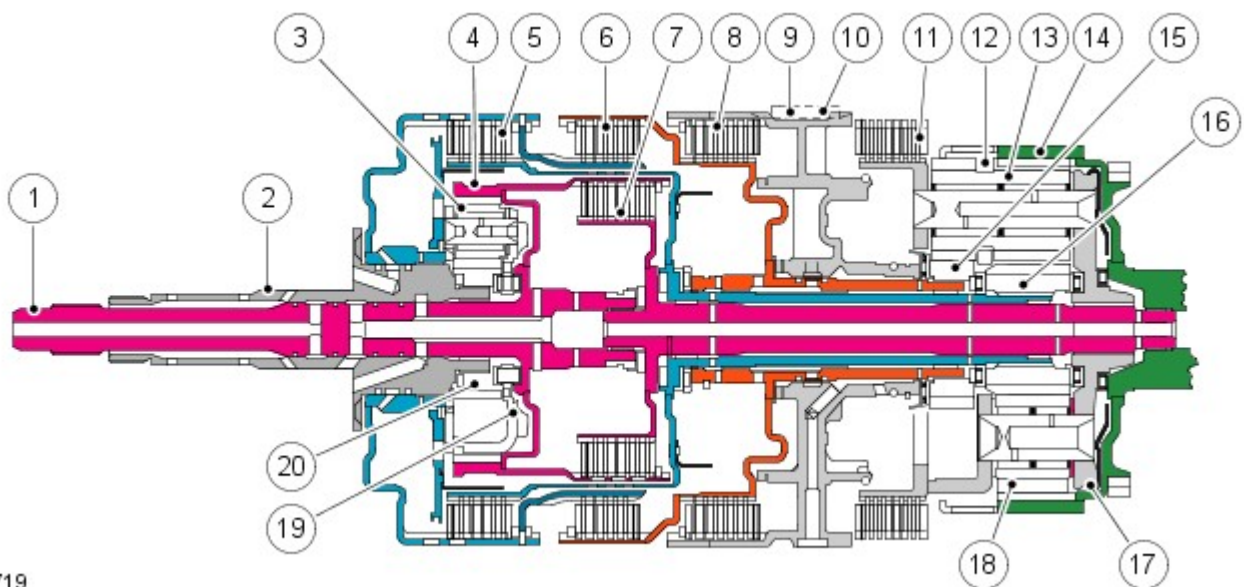

E42719

Item	Part Number	Description
1	-	Turbine shaft
2	-	Stator shaft
3	-	Single web planetary gear train

4	-	Ring gear 1
5	-	Clutch A
6	-	Clutch B
7	-	Clutch E
8	-	Brake clutch C
9	-	Fixed connection to transmission housing
10	-	Shaft key
11	-	Brake clutch D
12	-	Double web planetary gear train
13	-	Planetary gears - long
14	-	Ring gear 2
15	-	Sunwheel 2
16	-	Sunwheel 3
17	-	Double web planetary gear carrier
18	-	Planetary gears - short
19	-	Single web planetary gear carrier
20	-	Sunwheel 1

The shift elements are three rotating multiplate clutches (A, B and E) and two fixed multiplate brakes © and D). All shifts from 1st to 6th gears are power-on overlapping shifts. Overlapping shifts can be described as one of the clutches continuing to transmit drive at a lower main pressure until the next required clutch is able to accept the input torque.

The shift elements, clutches and brakes are actuated hydraulically. Fluid pressure is applied to the required clutch and/or brake, pressing the plates together and allowing drive to be transmitted through the plates. The purpose of the shift elements is to perform power-on shifts with no interruption to traction and smooth transition between gear ratios.

Power Flow 1st Gear

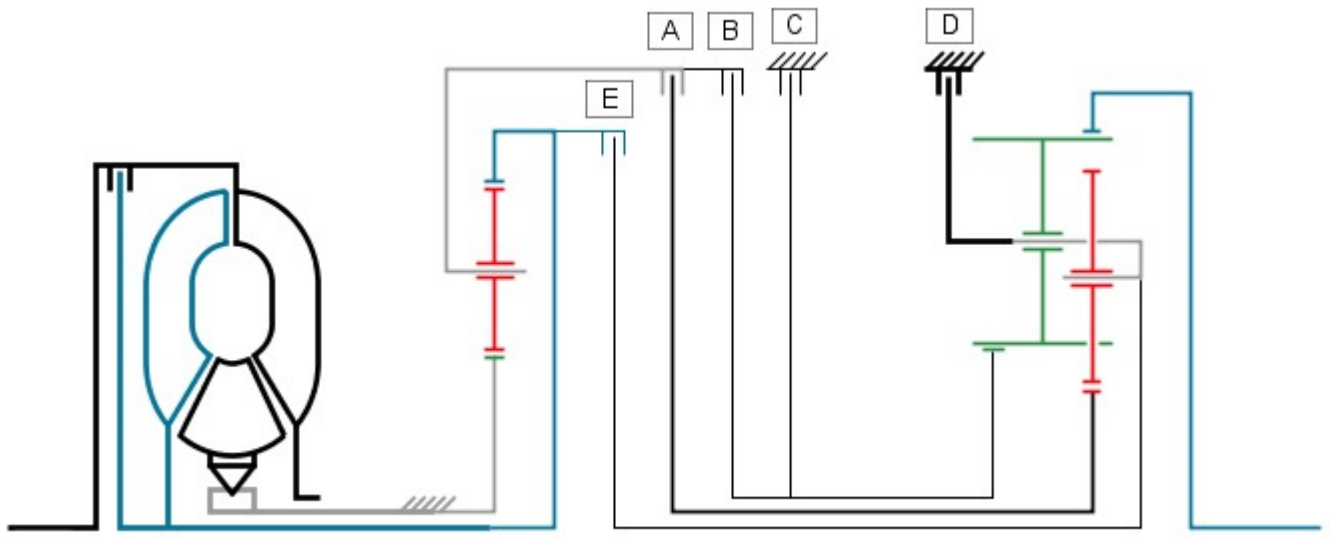

E42720

The selector lever and the selector valve spool are in the 'D' position. Engine torque is transmitted from the torque converter turbine shaft to the ring gear 1 of the single web planetary gear train and the outer plate carrier of clutch 'E'.

Ring gear 1 drives the planetary gears which rotate around sunwheel 1. This drives the planetary gear carrier 1 and also the outer plate carrier of clutch 'A' and the inner plate carrier of clutch 'B'.

When clutch 'A' is engaged, sunwheel 3 in the double web planetary gear train is driven and meshes with the short planetary gears.

The double web planetary gear train is locked against the transmission housing by brake 'D'. This allows ring gear 2 (output shaft) to be driven in the same direction as the engine via the long planetary gears.

- NOTE: Refer to 'Shift Elements' illustration for key

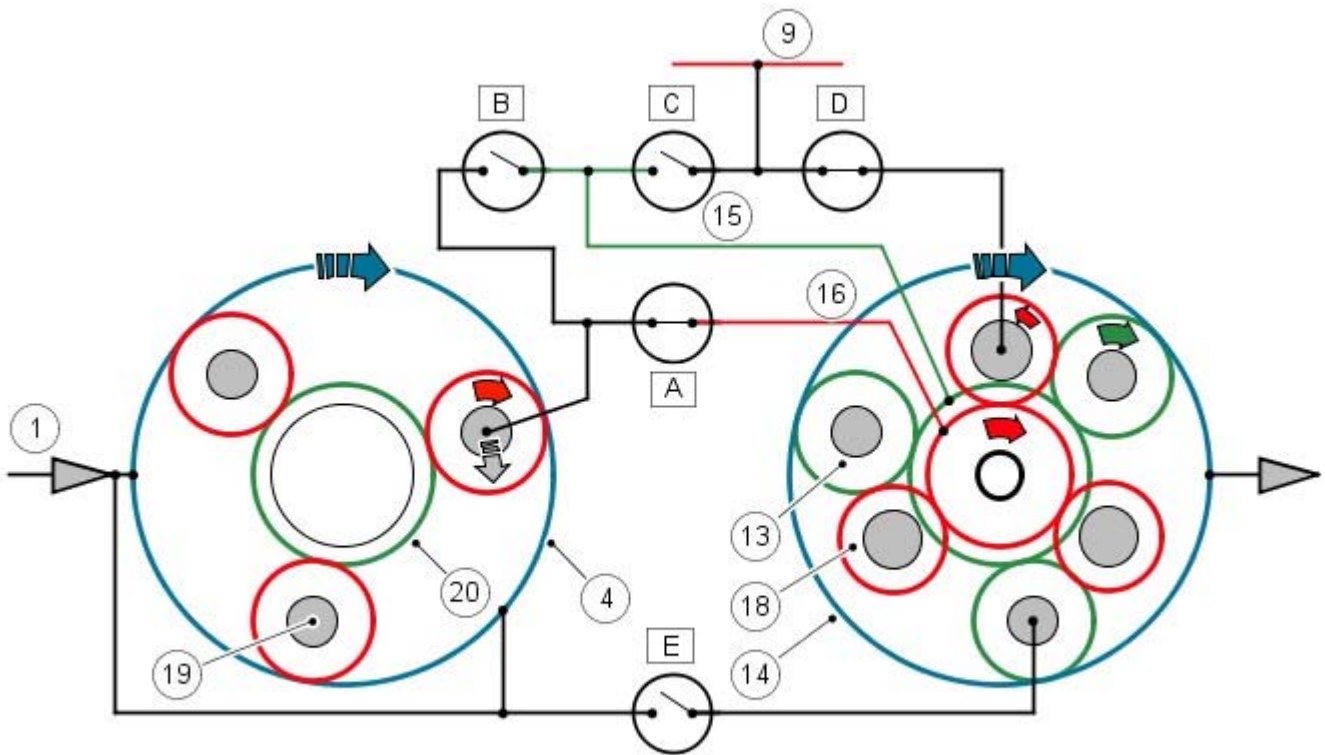

E42721

Power Flow 2nd Gear

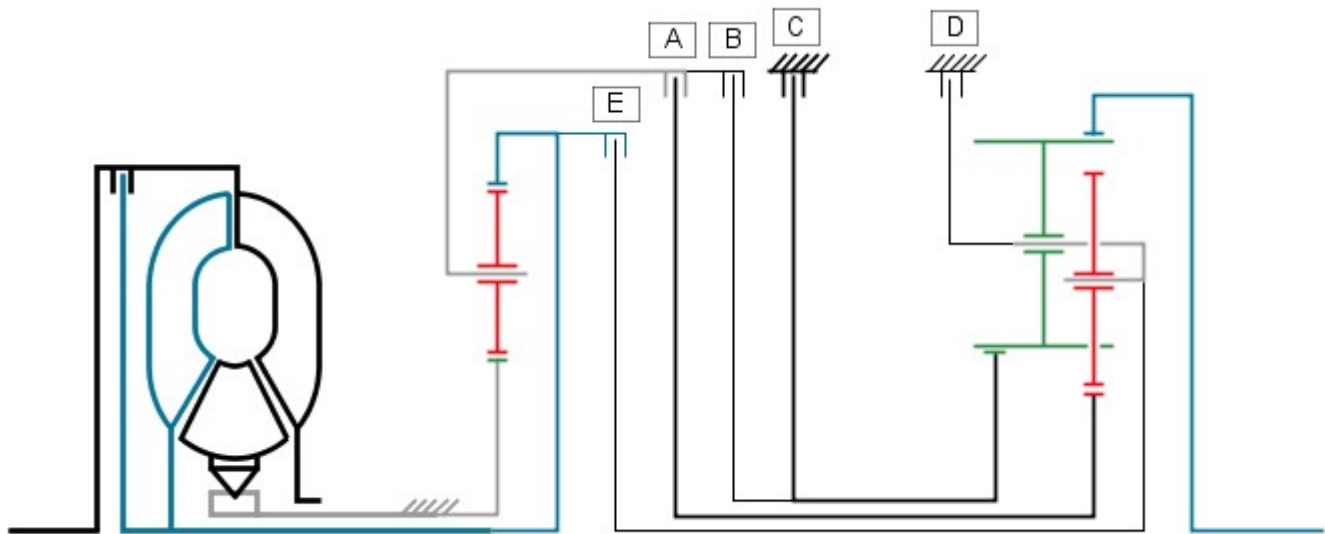

E42722

The selector lever and the selector spool valve are in the 'D' position. Engine torque is transmitted from the torque converter turbine shaft to the ring gear 1 of the single web planetary gear train and the outer plate carrier of clutch 'E'.

Ring gear 1 drives the planetary gears which rotate around sunwheel 1. This drives the planetary gear carrier 1 and also the outer plate carrier of clutch 'A' and the inner plate carrier of clutch 'B'.

When clutch 'A' is engaged, sunwheel 3 in the double web planetary gear train is driven and meshes with the short planetary gears.

Sunwheel 2 is locked to the transmission housing by brake clutch 'C'. The long planetary gears, which are also meshed with the short planetary gears, roll around the fixed sunwheel 2 and transmit drive to the double web planetary gear train carrier and ring gear 2 in the direction of engine rotation.

• NOTE: Refer to 'Shift Elements' illustration for key

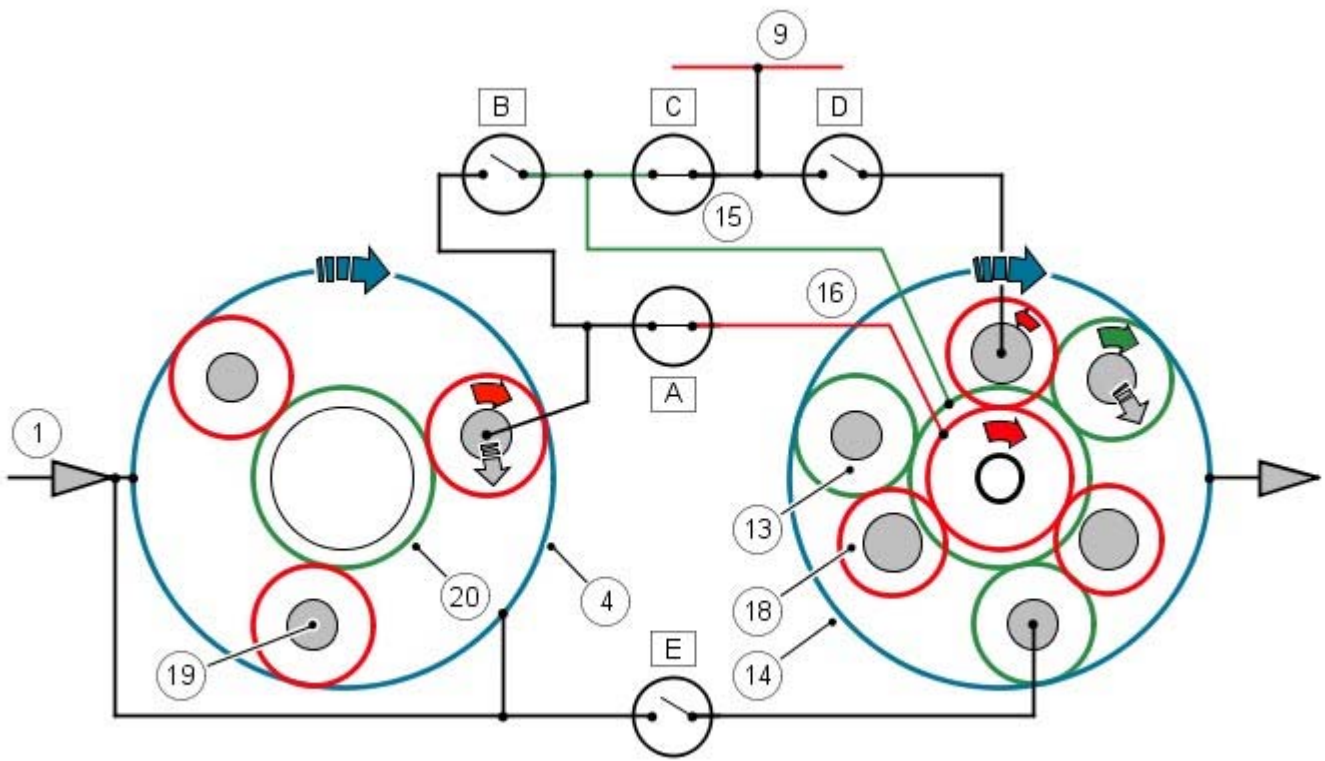

E42723

Power Flow 3rd Gear

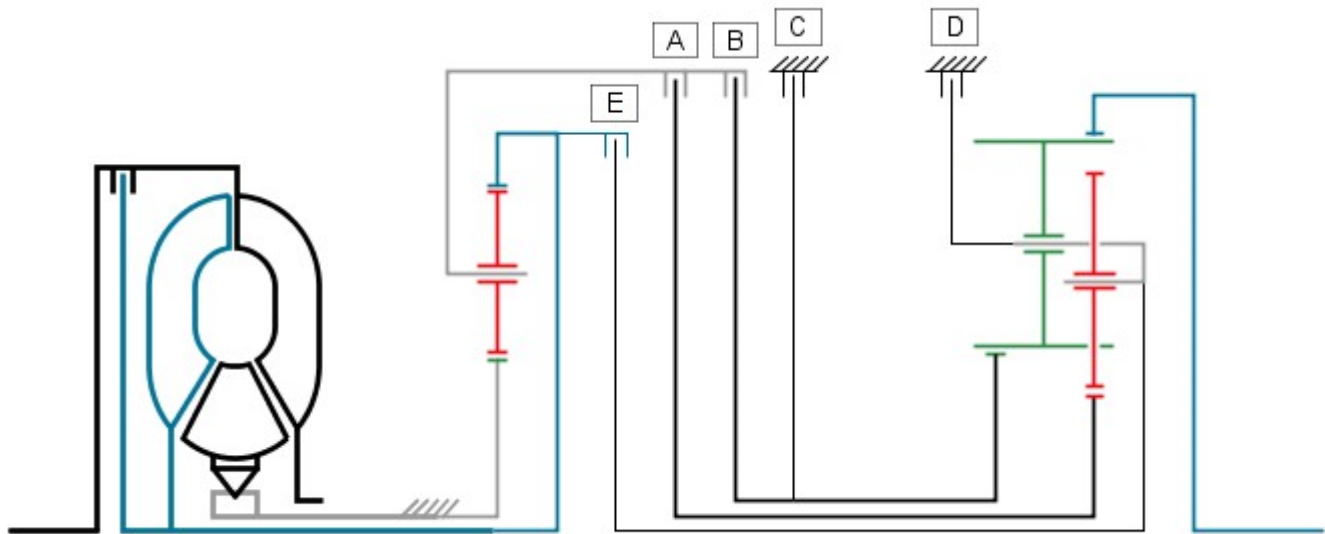

E 42724

The selector lever and the selector spool valve are in the 'D' position. Engine torque is transmitted from the torque converter turbine shaft to the ring gear 1 of the single web planetary gear train and the outer plate carrier of clutch 'E'.

Ring gear 1 drives the planetary gears which rotate around sunwheel 1. This drives the planetary gear carrier 1 and also the outer plate carrier of clutch 'A' and the inner plate carrier of clutch 'B'.

When clutch 'A' is engaged, sunwheel 3 in the double web planetary gear train is driven and meshes with the short planetary gears.

Sunwheel 2 is driven via clutch 'B' which is engaged. The long planetary gears, which are also meshed with the short planetary gears, cannot roll around the fixed sunwheel 2 and therefore transmit drive to the locked double web planetary gear train carrier in the direction of engine rotation.

• NOTE: Refer to 'Shift Elements' illustration for key

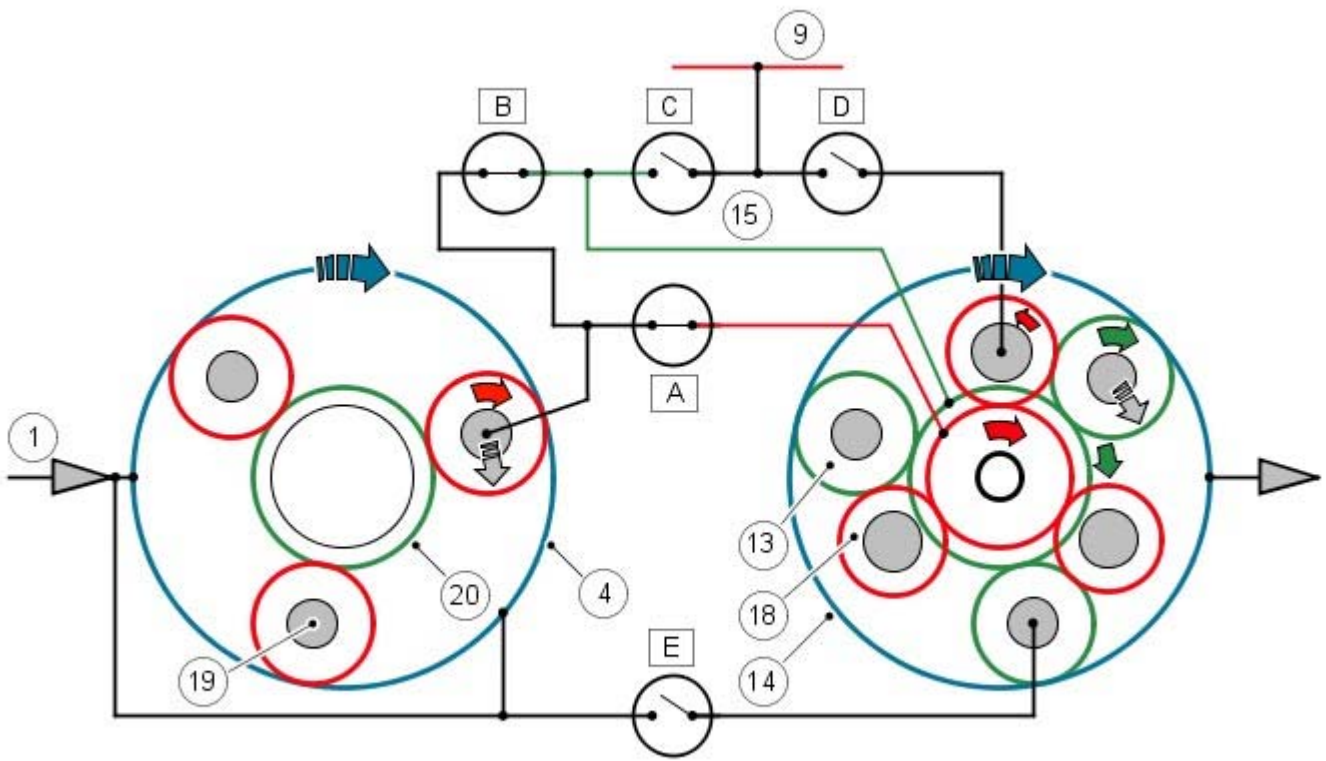

E42725

Power Flow 4th Gear

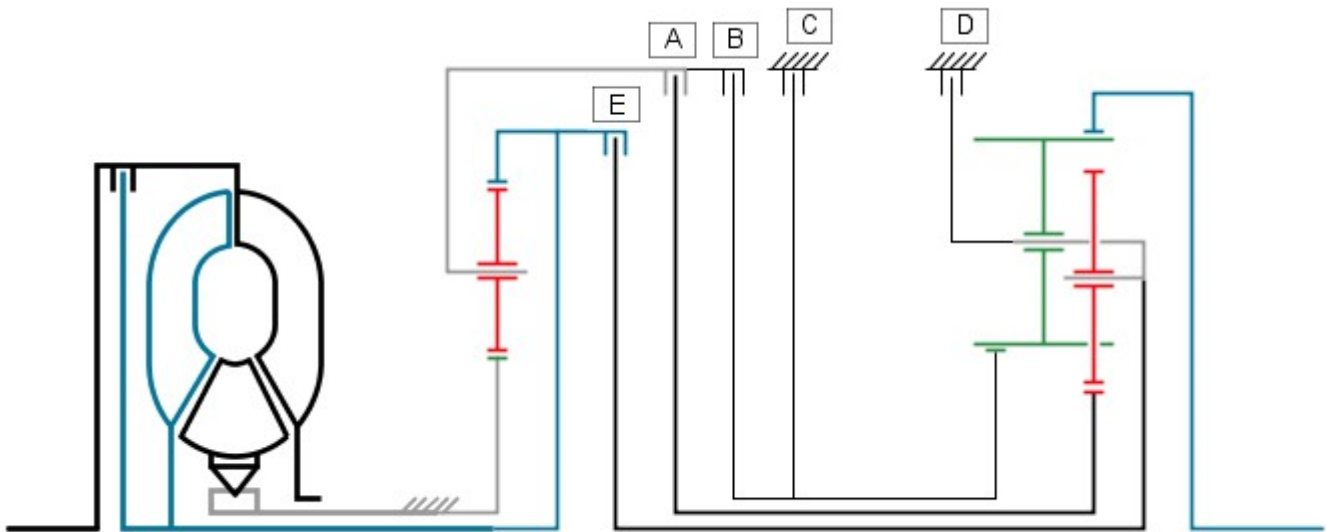

E42726

The selector lever and the selector spool valve are in the 'D' position. Engine torque is transmitted from the torque converter turbine shaft to ring gear 1 of the single web planetary gear train and the outer plate carrier of clutch 'E'.

Ring gear 1 drives the planetary gears which rotate around sunwheel 1. This drives the planetary gear carrier 1 and also the outer plate carrier of clutch 'A' and the inner plate carrier of clutch 'B'.

When clutch 'A' is engaged, sunwheel 3 in the double web planetary gear train is driven and meshes with the short planetary gears.

The double web planetary gear carrier is driven via clutch 'E' which is engaged. The long planetary gears, which are also meshed with the short planetary gears and the double web planetary gear carrier, drive ring gear 2 in the direction of engine rotation.

- NOTE: Refer to 'Shift Elements' illustration for key

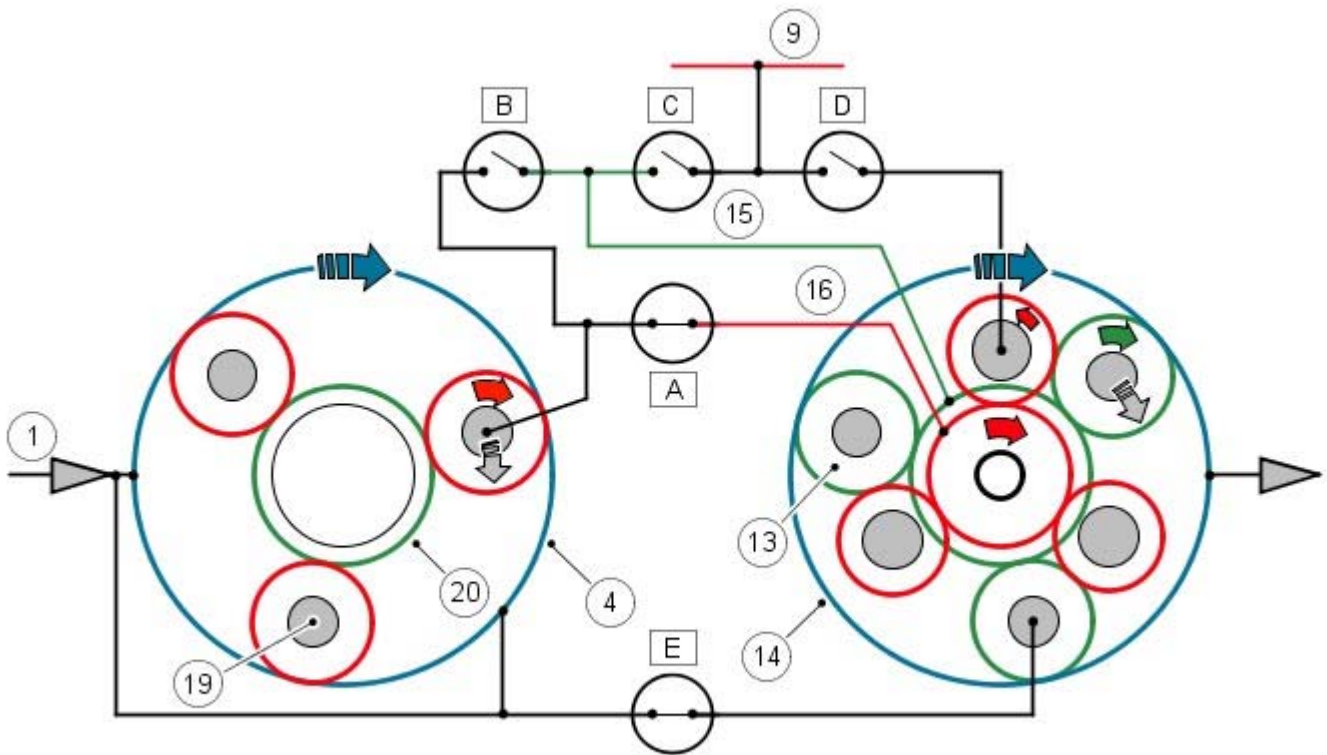

E42727

Power Flow 5th Gear

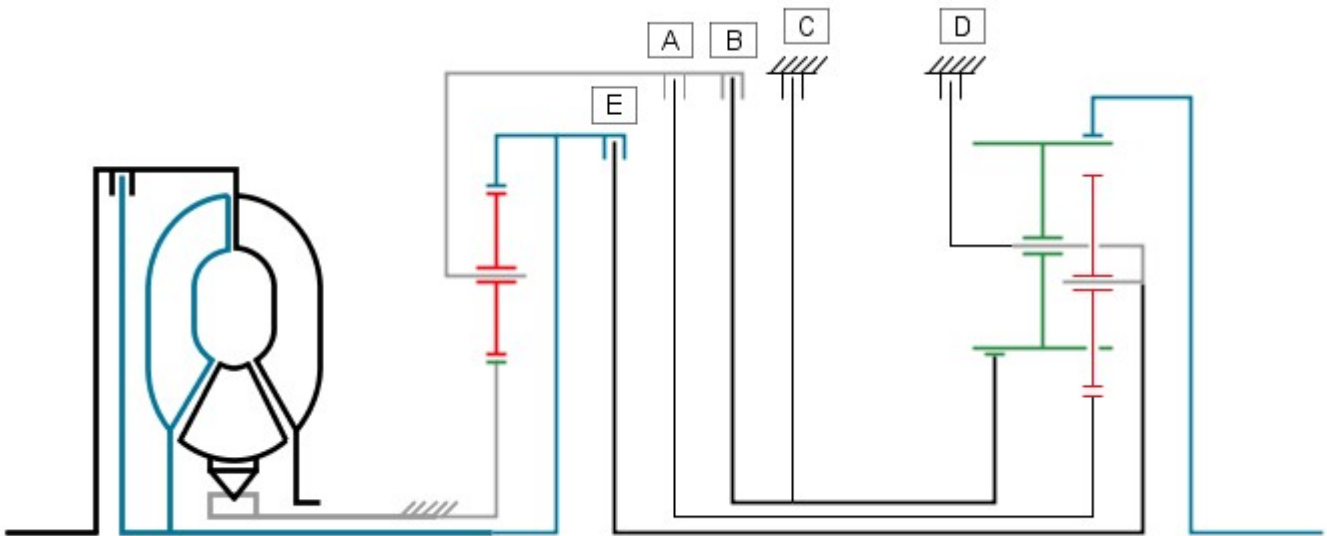

E42728

The selector lever and the selector spool valve are in the 'D' position. Engine torque is transmitted from the torque converter turbine shaft to ring gear 1 of the single web planetary gear train and the outer plate carrier of clutch 'E'.

Ring gear 1 drives the planetary gears which rotate around sunwheel 1. This drives the planetary gear carrier 1 and also the outer plate carrier of clutch 'A' and the inner plate carrier of clutch 'B'.

When clutch 'A' is engaged, sunwheel 3 in the double web planetary gear train is driven and meshes with the short planetary gears.

The long planetary gears, which are also meshed with the short planetary gears and the double web planetary gear carrier, drive ring gear 2 in the direction of engine rotation.

• NOTE: Refer to 'Shift Elements' illustration for key

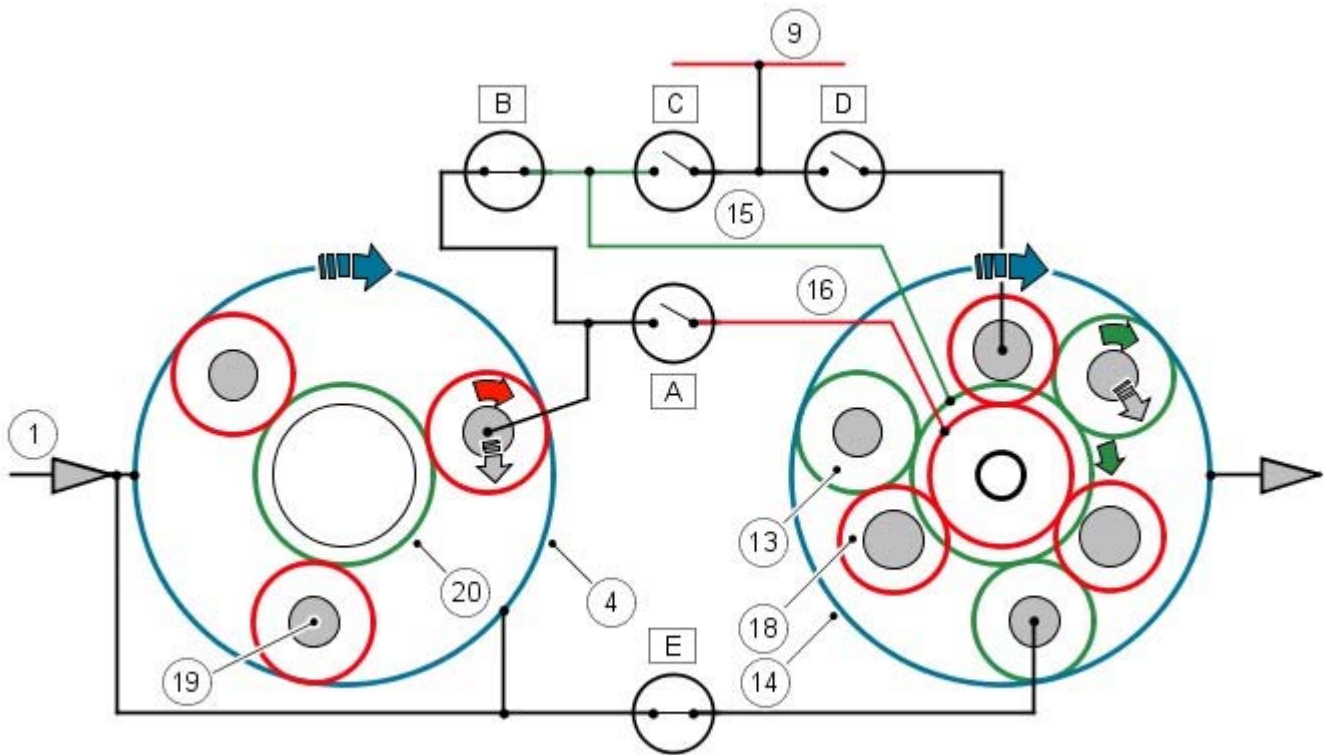

E42729

Power Flow 6th Gear

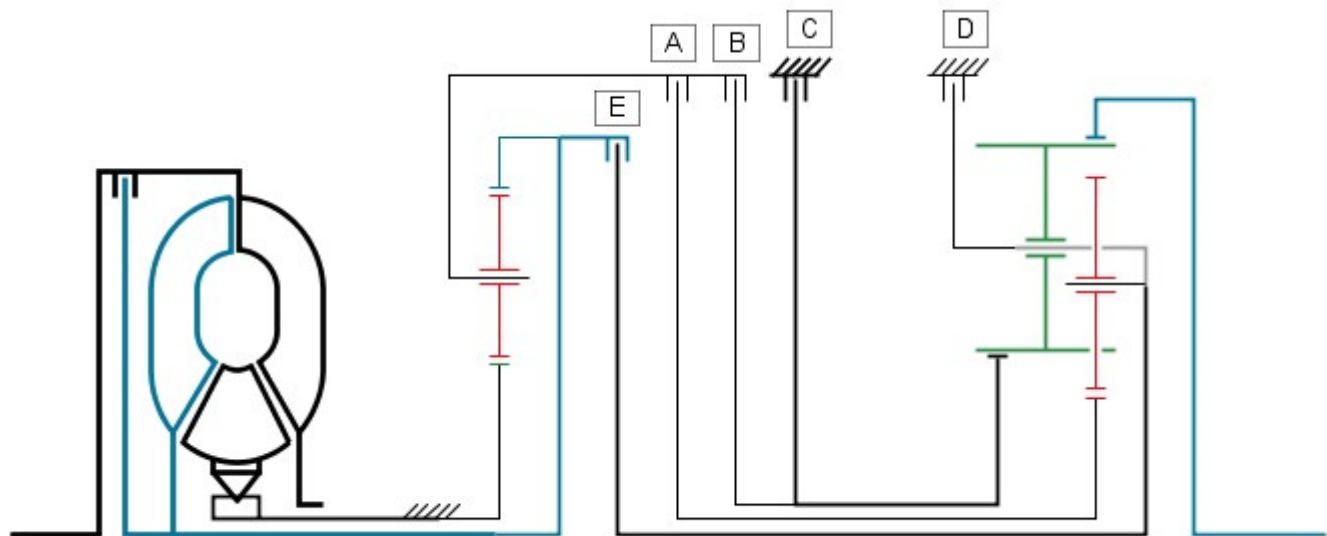

E42730

The selector lever and the selector spool valve are in the 'D' position. Engine torque is transmitted from the torque converter turbine shaft to ring gear 1 of the single web planetary gear train and the outer plate carrier of clutch 'E'.

Clutches 'A' and 'B' are released, removing the effect of the single web planetary gear train.

Clutch brake 'C' is applied which locks sunwheel 2 to the transmission housing.

Clutch 'E' is engaged and drives the double web planetary gear carrier. This causes the long planetary gears to rotate around the fixed sunwheel 2 and transmit drive to ring gear 2 which is driven in the direction of engine rotation.

• NOTE: Refer to 'Shift Elements' illustration for key

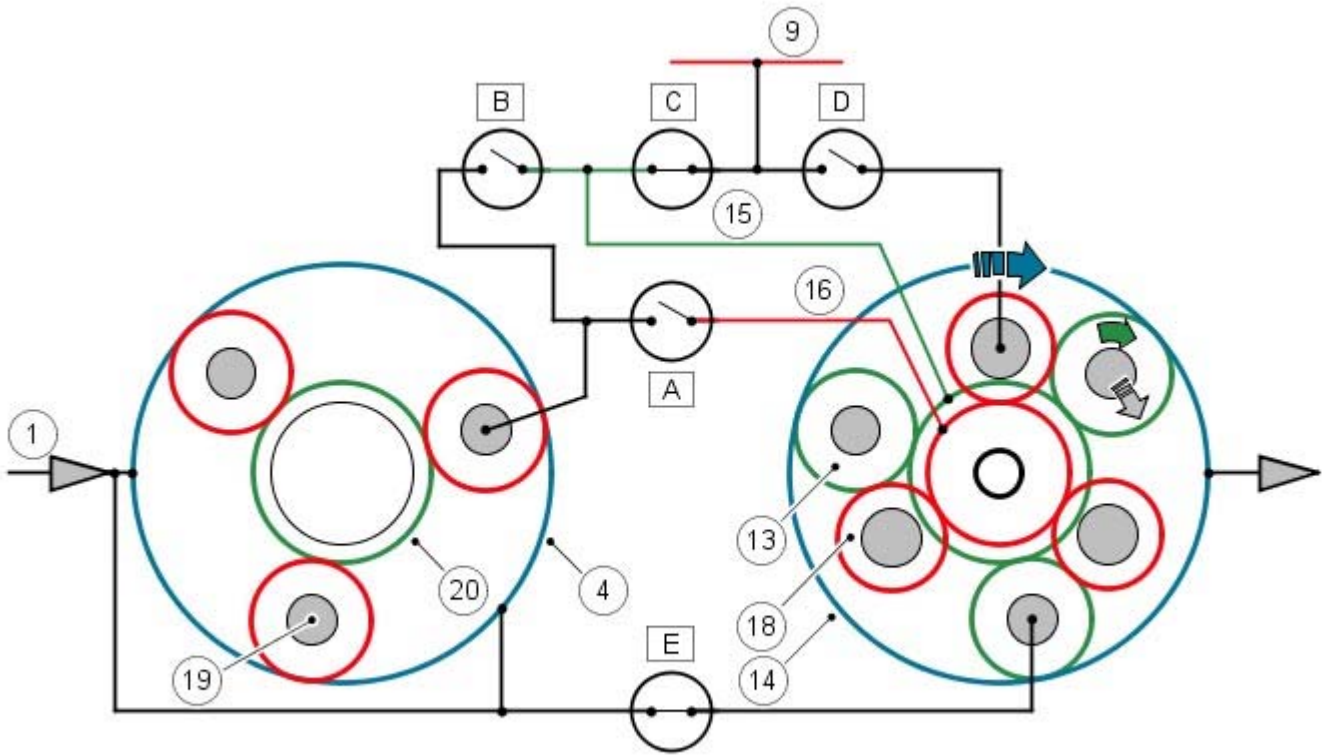

E42731

Power Flow Reverse Gear

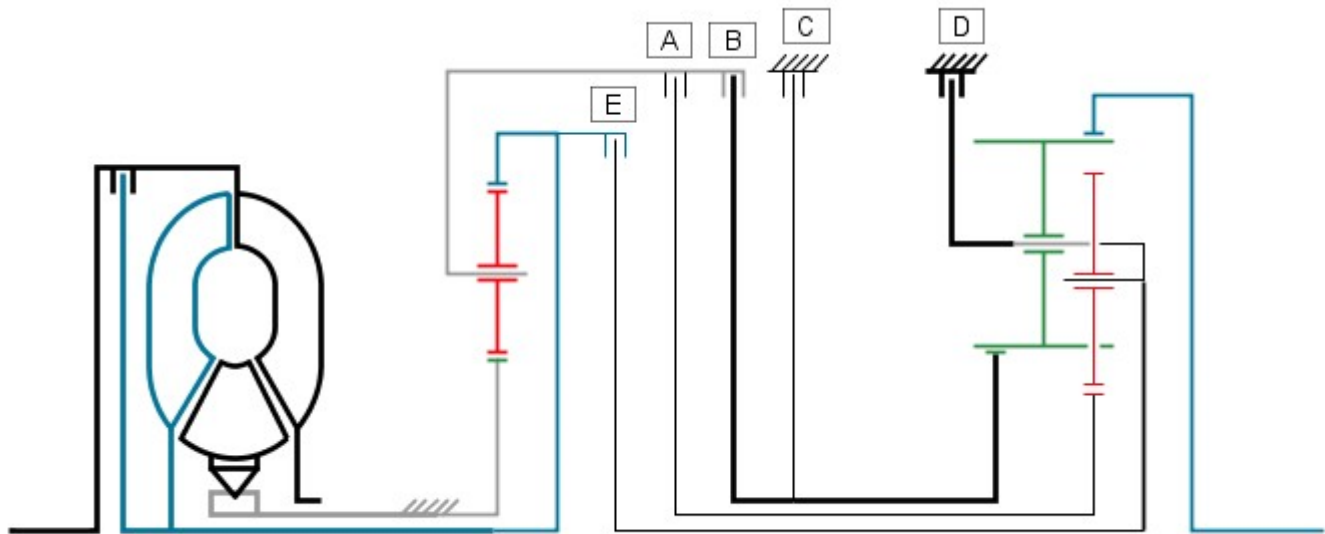

E42732

The selector lever and the selector spool valve are in the 'R' position. Engine torque is transmitted from the torque converter turbine shaft to ring gear 1 of the single web planetary gear train and the outer plate carrier of clutch 'E'.

Ring gear 1 drives the planetary gears of the single web planetary gear train which rotate around the fixed sunwheel 1. This transmits the drive to the single web planetary gear carrier, the outer plate carrier of clutch 'A' and the inner plate carrier of clutch 'B'.

With clutch 'B' applied, sunwheel 2 in the double web planetary gear train is driven and meshes with the long planetary gears.

The double web planetary gear carrier is locked to the transmission housing by brake clutch 'D'. This allows ring gear 2 to be driven in the opposite direction to engine rotation by the long planetary gears.

• NOTE: Refer to 'Shift Elements' illustration for key

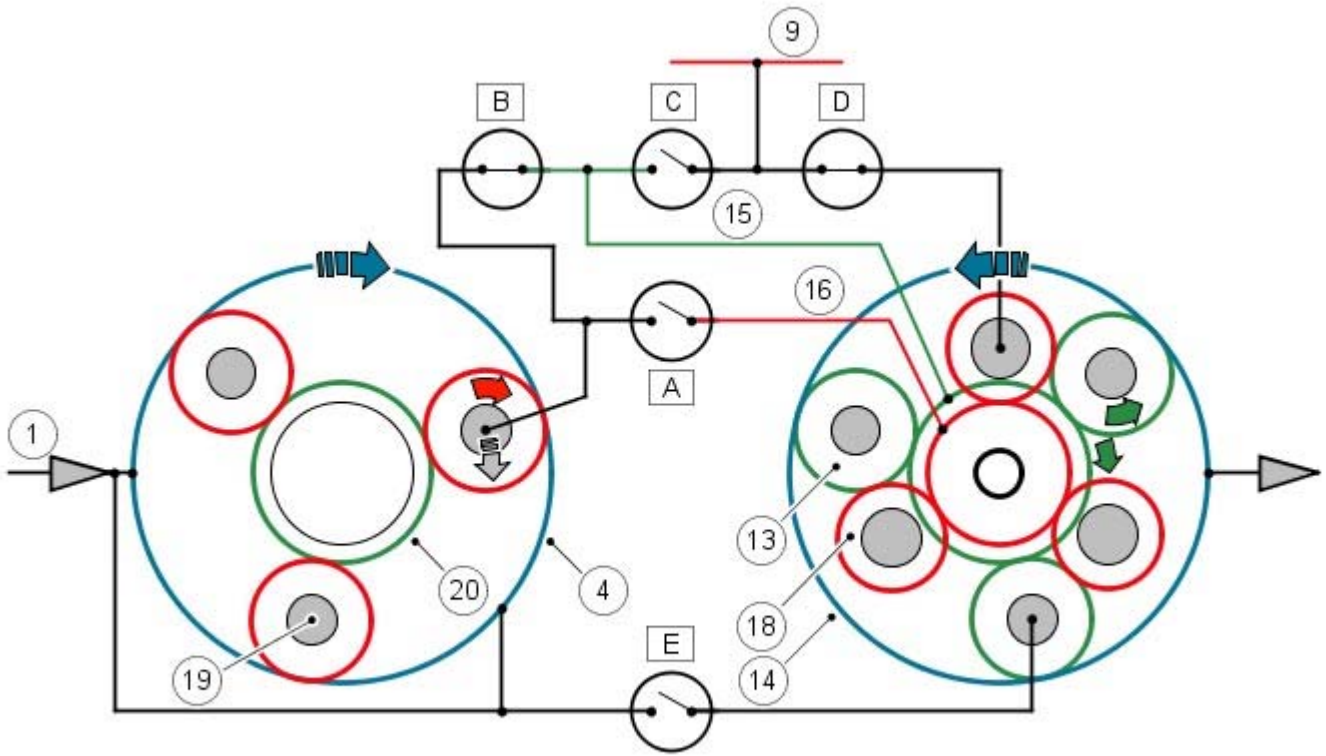

E42733

Instrument Cluster

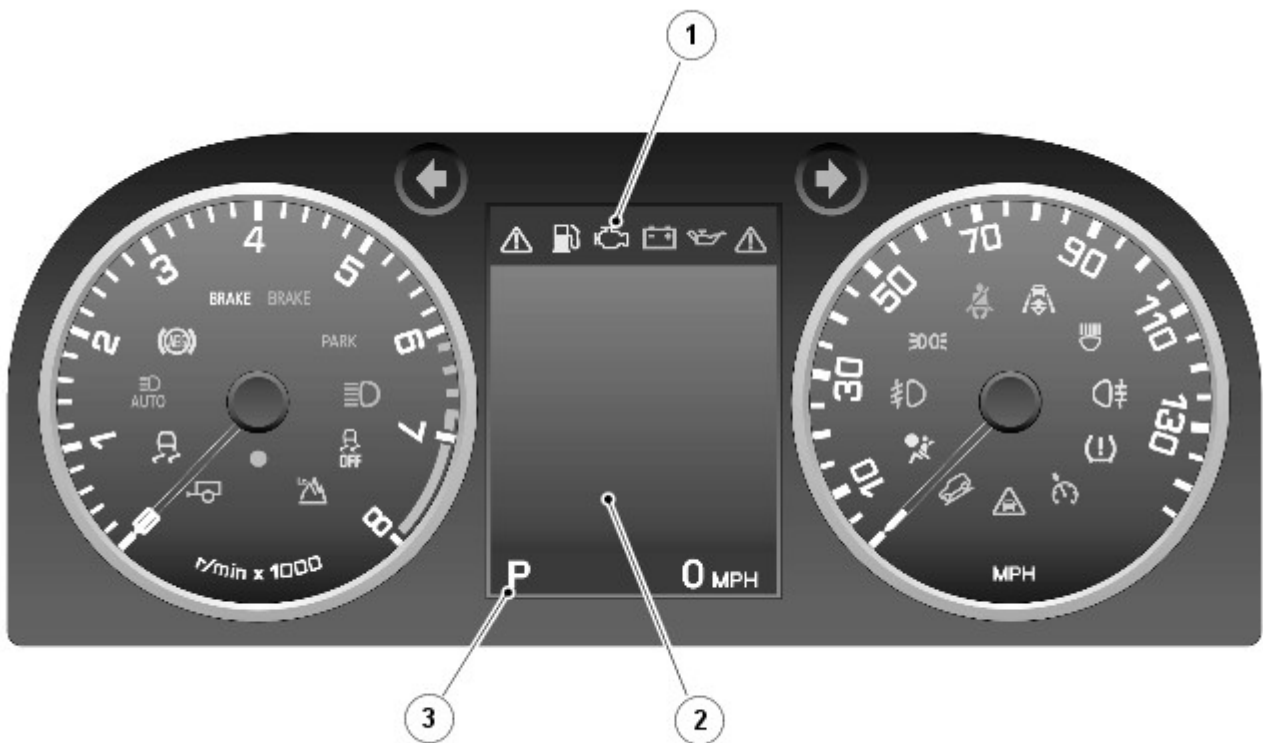

E121495

Item	Part Number	Description
1	-	MIL (malfunction indicator lamp)
2	-	Message center
3	-	Transmission status display

The instrument cluster is connected to the [TCM](#) via the high speed [CAN](#) bus. Transmission status is transmitted by the [TCM](#) and displayed to the driver in one of two displays in the instrument cluster. For additional information, refer to: [Instrument Cluster](#) (413-01 Instrument Cluster, Description and Operation).

Malfunction Indicator Lamp

The **MIL (malfunction indicator lamp)** is located in the tachometer of the instrument cluster. Transmission related faults which may affect the vehicle emissions will illuminate the **MIL**.

The **MIL** is illuminated by the **ECM** on receipt of a relevant fault message from the **TCM** on the high speed **CAN**. The nature of the fault can be diagnosed using Land Rover approved diagnostic equipment which reads the fault codes stored in the **TCM** memory.

Transmission Status Display

The transmission status display is located in the tachometer of the instrument cluster. The display shows the selector lever position or the selected gear when in manual and sport modes.

The following table shows the displays and their descriptions.

Symbol	Description
P	Park selected
R	Reverse selected
N	Neutral selected
D	Drive selected
s*	Sport mode selected (* = current gear)
1	1st gear selected (manual CommandShift mode)
2	2nd gear selected (manual CommandShift mode)
3	3rd gear selected (manual CommandShift mode)
4	4th gear selected (manual CommandShift mode)
5	5th gear selected (manual CommandShift mode)
6	6th gear selected (manual CommandShift mode)

Message Center

The message center is located in the center of the instrument cluster. The message center is a **LCD (liquid crystal display)** that relays vehicle status and operating information to the driver and can display messages relating to a number of vehicle systems. If a transmission fault occurs, the message GEARBOX FAULT is displayed in the message center. For additional information, refer to: [Information and Message Center](#) (413-08 Information and Message Center, Description and Operation).

Transmission Control Module

The **TCM** outputs signals to control the shift control solenoid valve and the EPRS to control the hydraulic operation of the transmission.

The **TCM** processes signals from the transmission speed and temperature sensors, the selector lever, the **ECM** and other vehicle systems. From the received signal inputs and pre-programmed data, the **TCM** calculates the correct gear, torque converter clutch setting and optimum pressure settings for gear shift and lock-up clutch control.

The **ECM** supplies the engine management data over the high speed **CAN** bus. The **TCM** requires engine data to efficiently control the transmission operation, for example; flywheel torque, engine speed, accelerator pedal angle, engine temperature. The steering angle sensor and the **ABS (anti-lock brake system)** module also supply data to the **TCM** on the high speed **CAN** bus. The **TCM** uses data from these systems to suspend gear changes when the vehicle is cornering and/or the **ABS** module is controlling braking or traction control.

Using the signal inputs and the memorized data, the **TCM** control program computes the correct gear and torque converter lock-up clutch setting and the optimum pressure settings for gear shift and lock-up clutch control. Special output-side modules (power output stages, current regulator circuits), allow the **TCM** to control the solenoid valves and pressure regulators and consequently precisely control the hydraulics of the automatic transmission. In addition, the amount and duration of engine interventions are supplied to the engine management by way of the **CAN** bus.

The **TCM** determines the position of the selector lever using signals from:

- The selector switch in the transmission.
- The park lock and M/S (manual/sport) 'CommandShift' switches on the selector lever.

When the driver operates the steering wheel paddle switches the selections are sensed by the **TCM**, which then operates in the manual CommandShift mode. If the selector lever is in D, the CommandShift mode is temporary and will cancel after a time period or can be cancelled by pressing and holding the + paddle for approximately 2 seconds. If the selector lever is in the M/S position, the CommandShift mode is permanent and can only be cancelled by pressing and holding the + paddle for approximately 2 seconds or by moving the selector lever to the D position.

The **TCM** transmits the position of the selector lever and the selected gear on the high speed **CAN** bus. This information is shown in the gear selector display in the instrument cluster.

Engine Stall

If the vehicle stalls it will coast down in gear, with the transmission providing drive to the engine. A restart can be attempted at this point and the engine may start and the driver can continue.

If the coast down speed reduces such that the speed of the engine is less than 600 rev/min, the transmission will go to neutral, D illumination will flash in the instrument cluster. The driver needs to select neutral or park and then press the brake pedal to restart the engine.

If the start/stop button is pressed when driving, the message ENGINE STOP BUTTON PRESSED is displayed in the message center but there will be no change to the ignition state. If the driver requires to switch off the engine, the start/stop button must be pressed for a second time. The engine will be stopped and will be back driven by the transmission as the vehicle coasts down.

Automatic Transmission/Transaxle - V8 5.0L Petrol/TDV6 3.0L Diesel - Diagnostics

Diagnosis and Testing

Principle of Operation

For a detailed description of the automatic transmission/transaxle system and operation, refer to the relevant Description and Operation sections in the workshop manual.

Fluid Level and Condition Check



CAUTION: The vehicle should not be driven if the fluid level is low as internal failure can result.

• **NOTE:** The transmission fluid temperature must not be allowed to exceed 50°C (122°F) whilst checking level. Should the temperature rise above this figure, abort the check and allow the transmission fluid to cool to below 30°C (86°F).

This vehicle is not equipped with a fluid level indicator. An incorrect level may affect the transmission operation and could result in transmission damage. To correctly check and add fluid to the transmission. Refer to the relevant section in the workshop manual.

High Fluid Level

A fluid level that is too high may cause the fluid to become aerated due to the churning action of the rotating internal parts. This will cause erratic control pressure, foaming, loss of fluid from the vent tube and possible transmission damage. If an overfill condition is identified, with the engine at idle ensure the fluid temperature is within the specified range and allow the excess fluid to drain until a small thread of fluid runs from the filler/level plug hole.

Low Fluid Level

A low fluid level could result in poor transmission engagement, slipping, or damage. This could also indicate a leak in one of the transmission seals or gaskets.

Adding Fluid



CAUTION: The use of any other type of transmission fluid other than that specified can result in transmission damage.

If fluid needs to be added, add fluid in 0.50 liter increments through the fill hole opening. Do not overfill the fluid. For fluid type, refer to the Specification section in the workshop manual.

Fluid Condition Check

1. **1.** Check the fluid level.
2. **2.** Observe the color and the odor of the fluid. The color under normal circumstances should be like honey, not dark brown or black.
3. **3.** Allow the fluid to drip onto a facial tissue and examine the stain.
4. **4.** If evidence of solid material is found, the transmission fluid pan should be removed for further inspection.

NOTE: In the event of a transmission unit replacement for internal failure, the oil cooler and pipes must also be replaced.

Inspection and Verification



CAUTION: Diagnosis by substitution from a donor vehicle is **NOT** acceptable. Substitution of control modules does not guarantee confirmation of a fault, and may also cause additional faults in the vehicle being tested and/or the donor vehicle.

1. **1.** Verify the customer concern.
2. **2.** Visually inspect for obvious signs of damage and system integrity.

Visual Inspection

Mechanical	Electrical	Hydraulic
<ul style="list-style-type: none"> ● Damaged/stuck shift mechanism ● Damaged automatic transmission casing 	<ul style="list-style-type: none"> ● Blown fuse(s) ● Damaged, loose or corroded connectors ● Wiring harness 	<ul style="list-style-type: none"> ● Fluid level too high/low ● Poor condition of fluid ● Fluid leak

3. **3.** If an obvious cause for an observed or reported concern is found, correct the cause (if possible) before proceeding to the next step.
4. **4.** If the cause is not visually evident check for Diagnostic Trouble Codes (DTCs) and refer to the DTC Index.

DTC Index

For a list of Diagnostic Trouble Codes (DTCs) that could be logged on this vehicle, please refer to Section 100-00.
REFER to: [Diagnostic Trouble Code \(DTC\) Index - DTC: Transmission Control Module \(TCM\) - Siemens](#) (100-00 General Information, Description and Operation).

Automatic Transmission/Transaxle - V8 5.0L Petrol/TDV6 3.0L Diesel - Transmission Fluid Level Check

General Procedures

Special Tool(s)

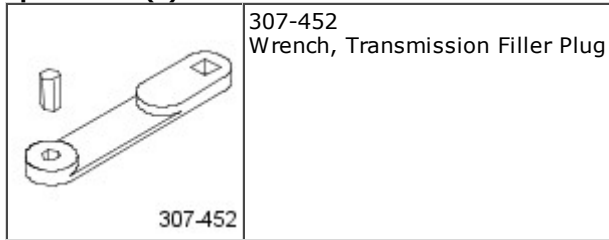

Check

• WARNINGS:



Observe due care when draining, as the fluid can be very hot.



Observe due care when working near a hot exhaust system.

• NOTE: Some variation in the illustrations may occur, but the essential information is always correct.

1.
 - The following steps must be observed before starting the transmission fluid level check.
 - The vehicle must be on a horizontal ramp.
 - The parking brake must be applied.
 - The engine must be running for 2 minutes with the transmission control switch (TCS) in the "P" position.

2.  **CAUTION:** Make sure that the transmission fluid temperature is below 30 degrees before starting the fluid level check.

Connect the diagnostic tool to the vehicle.

3.
 - Start the engine.
 - Apply, and hold, the footbrake.
 - Move the selector lever from 'P' through all gear positions, pausing in each gear position for 2-3 seconds and return to the 'P' position.

4.  **WARNING:** Make sure to support the vehicle with axle stands.

Raise and support the vehicle.

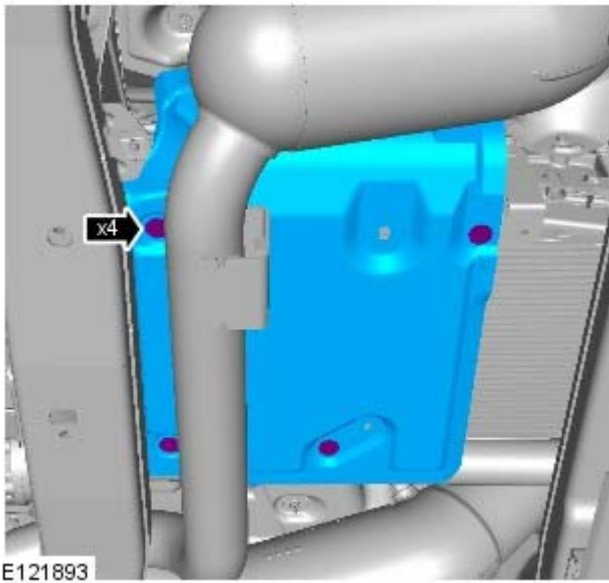

5. Torque: 9 Nm

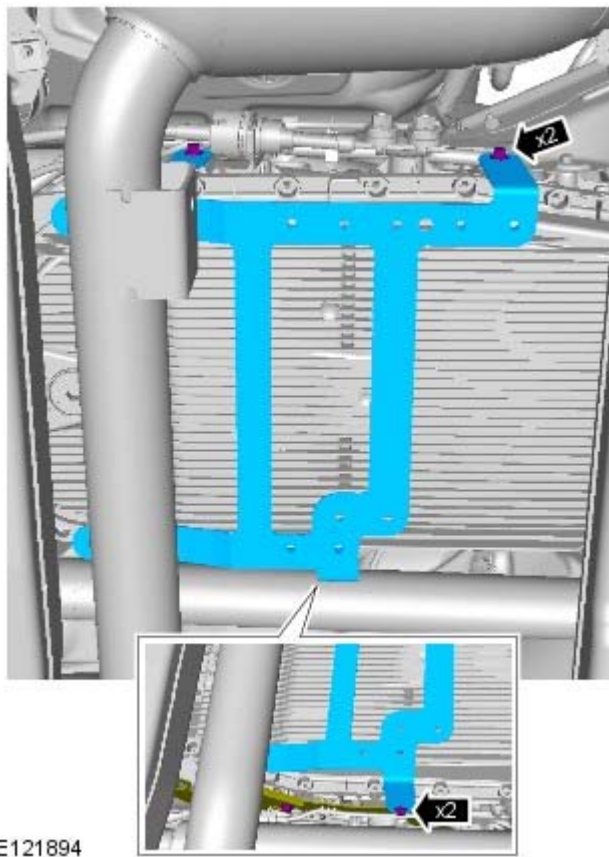

6. Torque: 9 Nm

7. Place a suitable container under the transmission fluid fill plug.

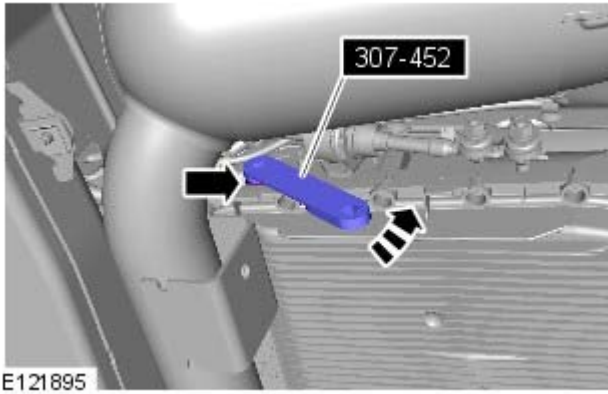

8. **8. WARNINGS:**

 Observe due care when draining, as the fluid can be very hot.

 Observe due care when working near a hot exhaust system.

• **CAUTIONS:**

 The transmission fluid level must only be checked when the temperature of the fluid is between 30 degrees and 50 degrees. The fluid level obtained will be incorrect if the reading is outside this temperature range.

 Discard the seal.

- *Special Tool(s):* [307-452](#)
- Clean the area around the transmission fluid level plug.

Adjustment

• **WARNINGS:**

 Observe due care when draining, as the fluid can be very hot.

 Observe due care when working near a hot exhaust system.

- **NOTE:** Some variation in the illustrations may occur, but the essential information is always correct.

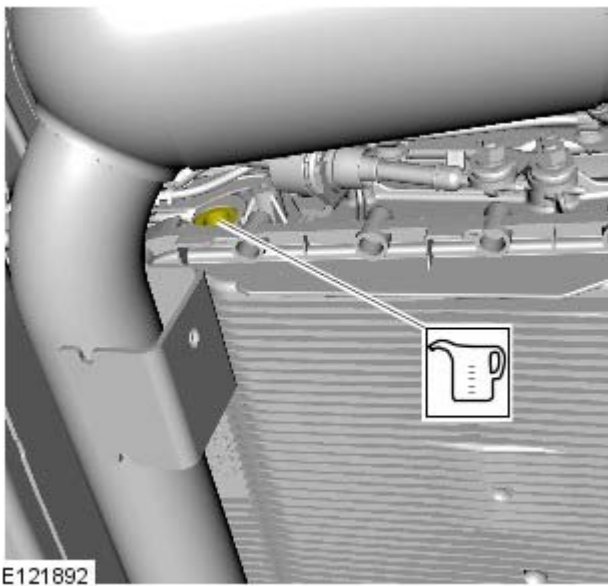

1. **9. NOTE:** Use transmission fluid meeting Land Rover specification.

If the transmission fluid does not come out of the transmission fluid fill plug hole the transmission fluid level is insufficient. If this is the case add the transmission fluid in 0.5 liter units into the transmission fluid fill plug hole until fluid comes out.

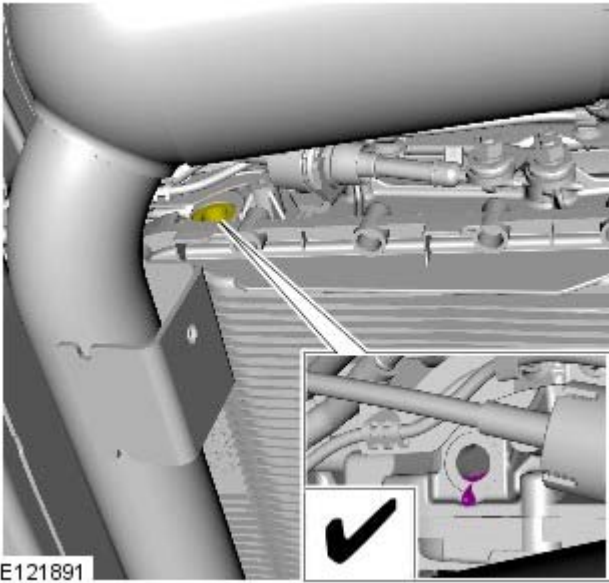

2. **10.** NOTE: Make sure the transmission fluid temperature does not exceed 50 °C (122 °F). If the transmission fluid temperature does exceed 50 °C (122 °F) stop the transmission fluid level check and allow the transmission fluid to cool until the temperature is below 30 °C (86 °F).

Allow the transmission fluid to drain from the transmission fluid filler plug hole until the flow almost stops.

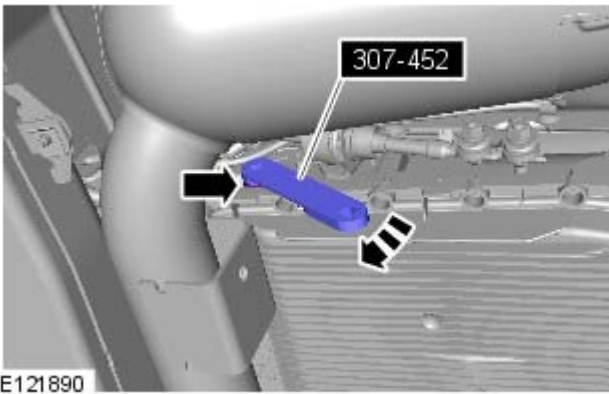

3. **11.** NOTE: Install a new sealing washer.

Using the special tool, install the new transmission fluid fill plug.

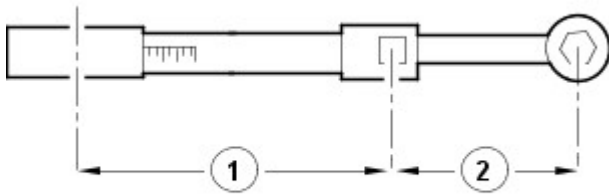

E37107

4. **12.** CAUTION: Make sure the transmission fluid fill plug is tightened to the correct specification. Failure to follow this instruction may result in damage to the vehicle.

- To make sure the transmission fill plug is torqued to the correct specification. Using the special tool and torque wrench the following calculation steps must be followed.
- Step 1. Multiply 35 Nm by the effective length of the torque wrench (1).
- Step 2. Add the effective length of the special tool (2) to the effective length of the torque wrench (1).
- Step 3. Divide the total of step 1 by the total of step 2.
- Step 4. Set the torque wrench to the figure arrived at in step 3.
- Tighten the transmission fluid fill plug to the torque given by the calculation.

5. Remove the special tool.

6. Remove the container.

7. Torque: 9 Nm

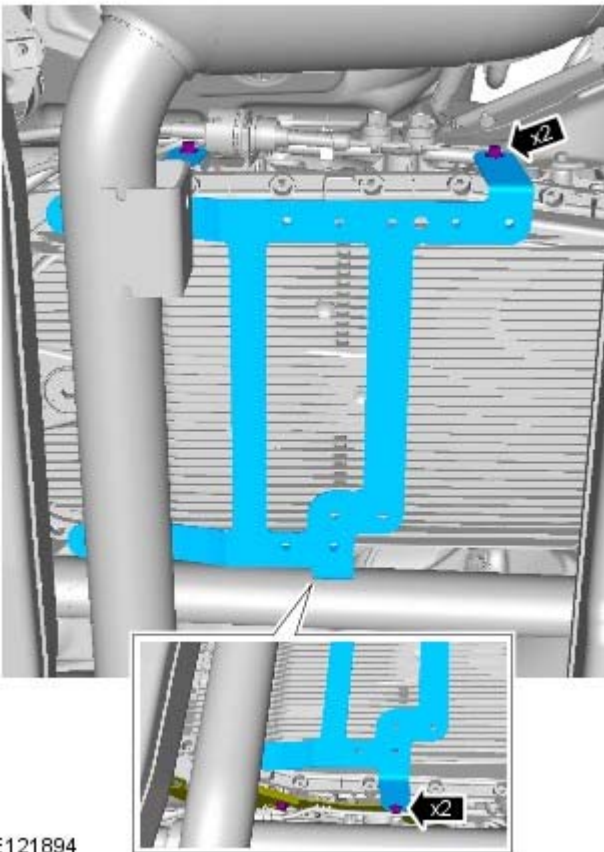

8. Torque: 9 Nm

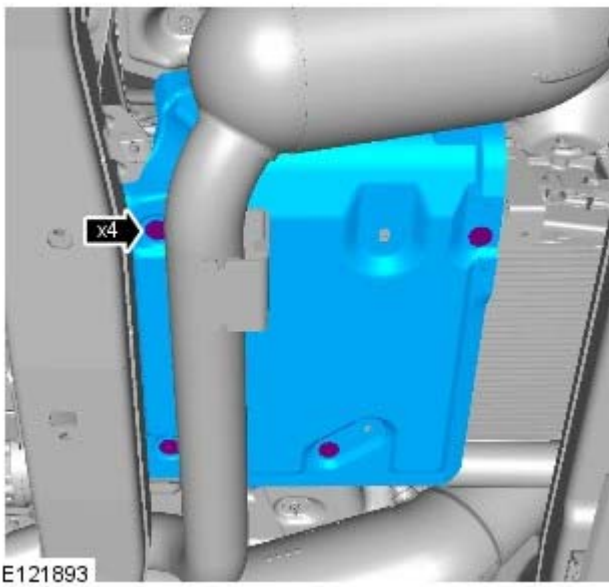

9. Lower the vehicle.

10. Disconnect the diagnostic tool from the vehicle.

Automatic Transmission/Transaxle - V8 5.0L Petrol/TDV6 3.0L Diesel - Transmission Fluid Drain and Refill

General Procedures

Special Tool(s)

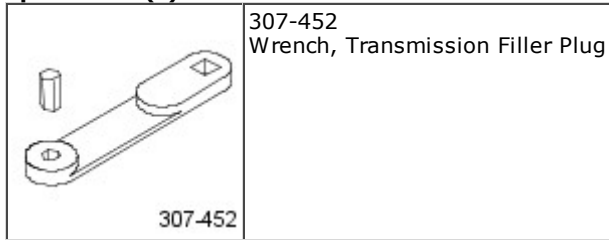

Drain

• WARNINGS:

 Observe due care when draining, as the fluid can be very hot.

 Observe due care when working near a hot exhaust system.

• NOTE: Some variation in the illustrations may occur, but the essential information is always correct.

1.  WARNING: Make sure to support the vehicle with axle stands.

Raise and support the vehicle.

2. Torque: 9 Nm

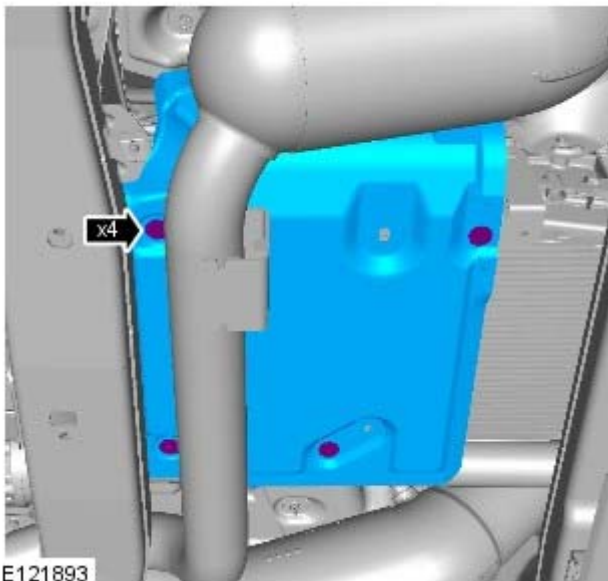

3. Torque: 9 Nm

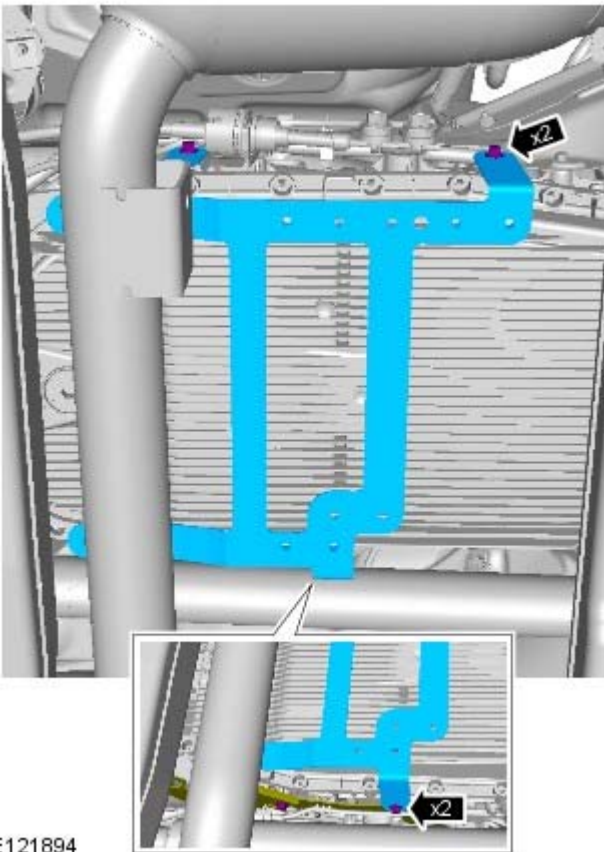

E121894

4. Place a container under the transmission.

5. Special Tool(s): [307-452](#)

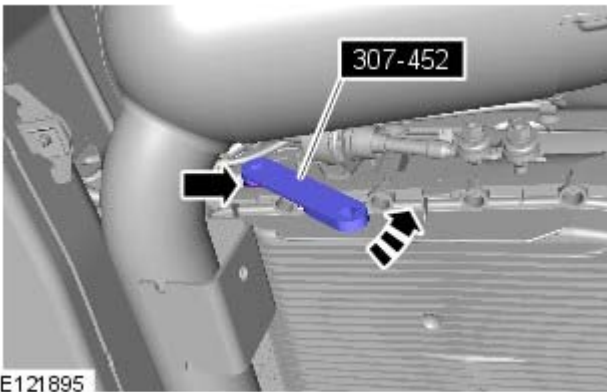

E121895

6.

- Allow the fluid to drain.
- Discard the component.

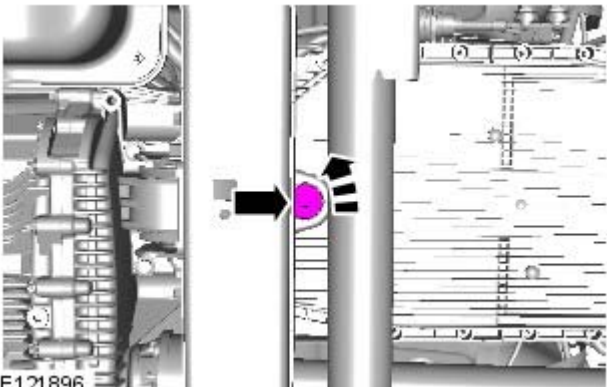

E121896

Filling

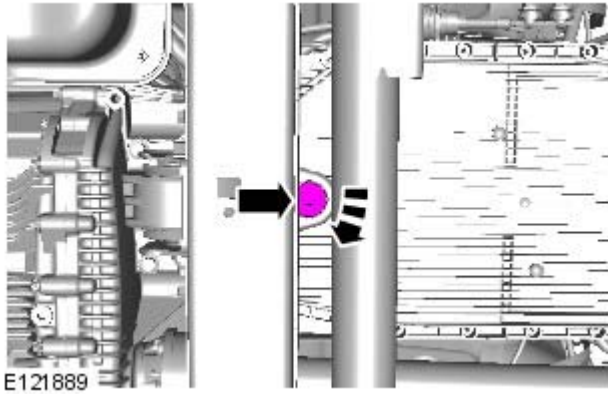

1. Torque: 8 Nm

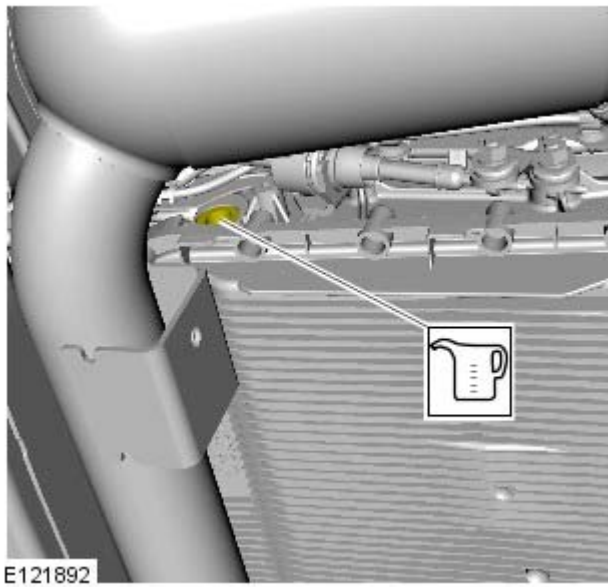

2.

- Refill the transmission with fluid.
- Use transmission fluid meeting Land Rover specification.

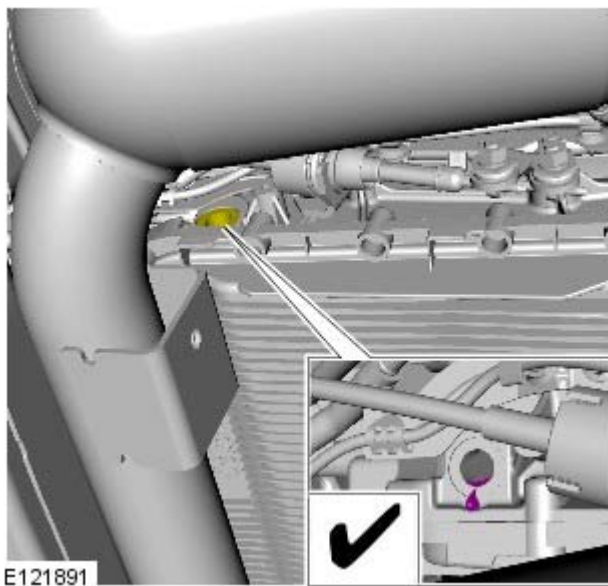

3. Allow the transmission fluid to drain from the transmission fluid filler plug hole until the flow almost stops.

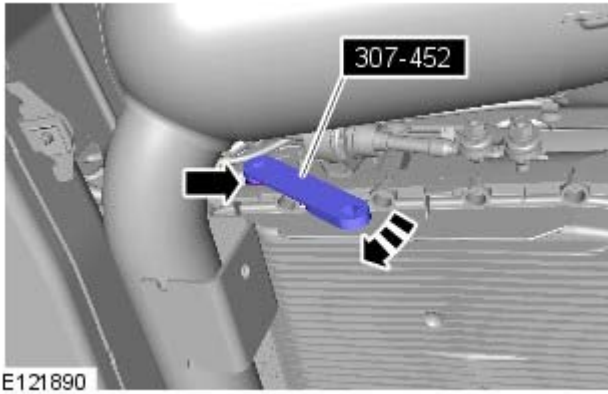

4. **4. NOTE:** Install a new sealing washer.

- Loosely install the transmission fluid fill plug.

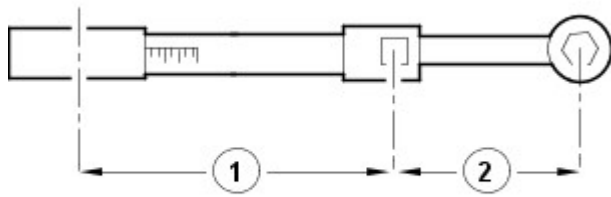

5. **5. ⚠ CAUTION:** Make sure the transmission fluid fill plug is tightened to the correct specification. Failure to follow this instruction may result in damage to the vehicle.

- To make sure the transmission fill plug is torqued to the correct specification. Using the special tool and torque wrench the following calculation steps must be followed.
- Step 1. Multiply 35 Nm by the effective length of the torque wrench (1).
- Step 2. Add the effective length of the special tool (2) to the effective length of the torque wrench (1).
- Step 3. Divide the total of step 1 by the total of step 2.
- Step 4. Set the torque wrench to the figure arrived at in step 3.
- Tighten the transmission fluid fill plug to the torque given by the calculation.

6. Carry out a transmission fluid level check.

Refer to: [Transmission Fluid Level Check](#) (307-01D Automatic Transmission/Transaxle - V8 5.0L Petrol/TDV6 3.0L Diesel, General Procedures).

7. Torque: 9 Nm

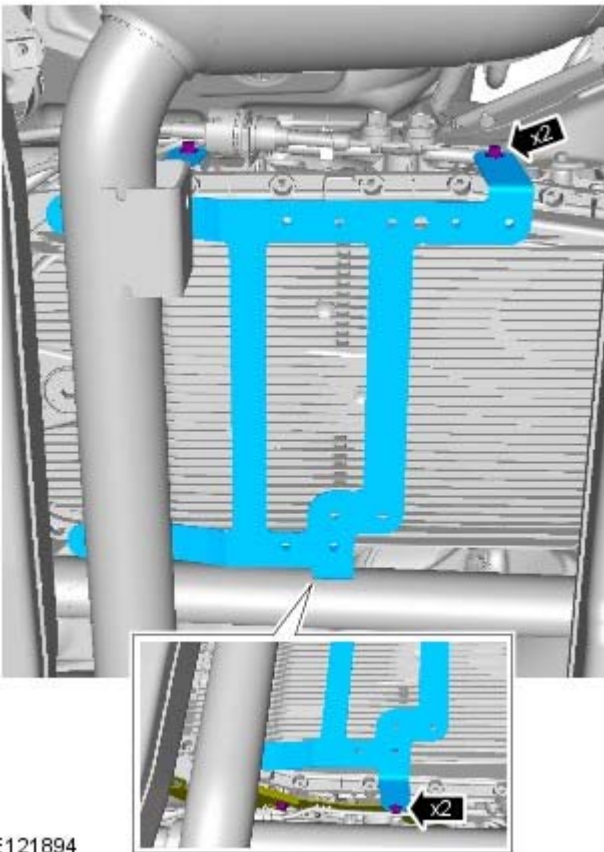

8. Torque: 9 Nm

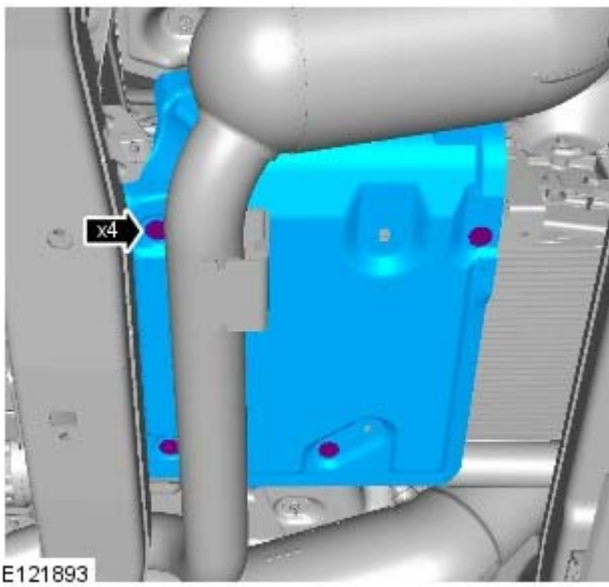



9. Lower the vehicle.

Automatic Transmission/Transaxle - V8 5.0L Petrol/TDV6 3.0L Diesel - Input Shaft Seal

Removal and Installation

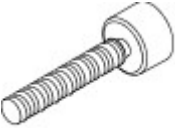
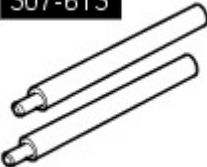
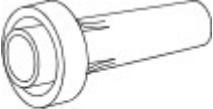
Special Tool(s)

 <p>100-012</p> <p>E54135</p>	<p>100-012 Slide Hammer</p>
 <p>100-012-01</p>	<p>100-012-01 Slide Hammer Adaptor</p>
 <p>307-613</p> <p>E84067</p>	<p>307-613 Holding Pins, Torque Converter</p>
 <p>308246</p>	<p>308-246 Front Seal Installer</p>
 <p>308-375</p>	<p>308-375 Seal Remover Input and Output</p>

Removal

1.  **WARNING:** Make sure to support the vehicle with axle stands.

Raise and support the vehicle.

2. Refer to: [Transmission - TDV6 3.0L Diesel](#) (307-01D Automatic Transmission/Transaxle - V8 5.0L Petrol/TDV6 3.0L Diesel, Removal). Refer to: [Transmission - V8 5.0L Petrol](#) (307-01D Automatic Transmission/Transaxle - V8 5.0L Petrol/TDV6 3.0L Diesel, Removal).

3. *Special Tool(s):* [307-613](#)

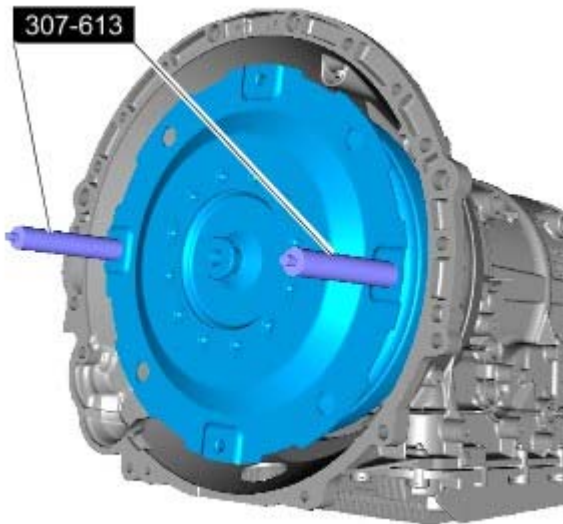

E112115

4. **4. CAUTIONS:**

 Take extra care not to damage the edges of the component.

 Discard the seal.

Special Tool(s): [100-012](#), [100-012-01](#), [308-375](#)

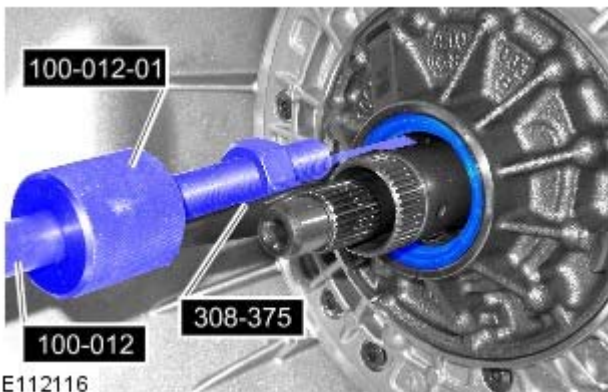

E112116

Installation



E112117

1. **1.**  **CAUTION:** Install a new seal.

Special Tool(s): [308-246](#)

2. **NOTE:** Make sure that the alignment mark is visible through the inspection hole as illustrated.

Special Tool(s): [307-613](#)

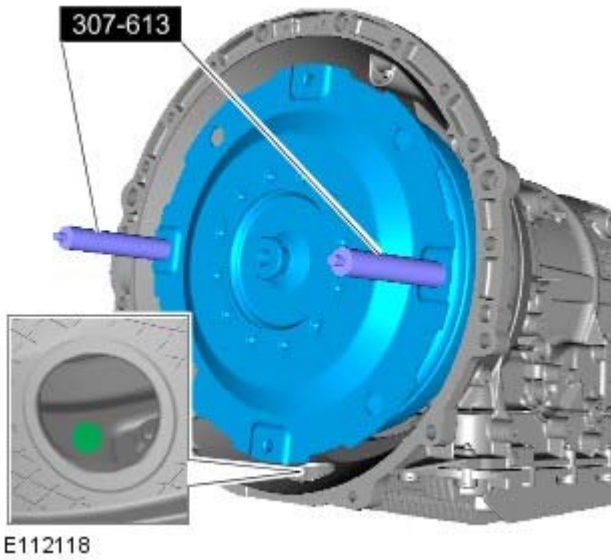

3. **CAUTION:** Make sure the torque converter is fully located into the oil pump drive.

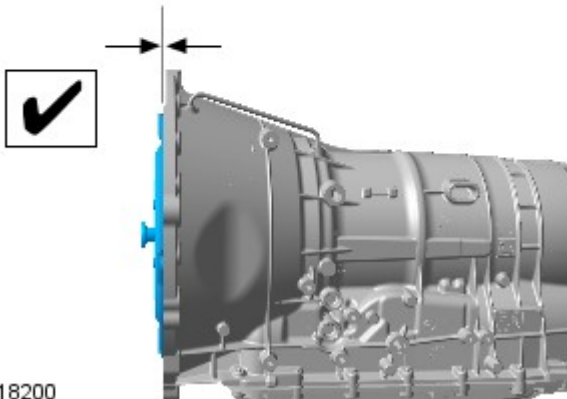
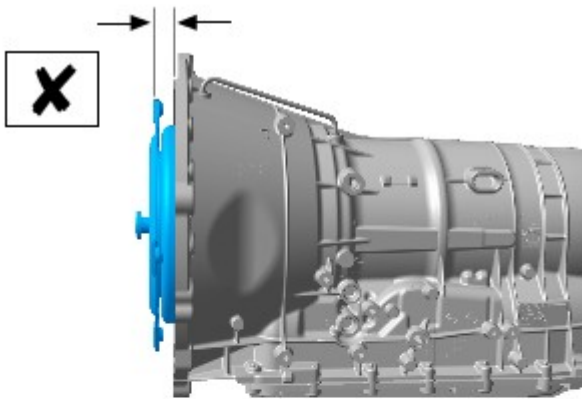

4. Refer to: [Transmission - V8 5.0L Petrol](#) (307-01D Automatic Transmission/Transaxle - V8 5.0L Petrol/TDV6 3.0L Diesel, Installation).
Refer to: [Transmission - TDV6 3.0L Diesel](#) (307-01D Automatic Transmission/Transaxle - V8 5.0L Petrol/TDV6 3.0L Diesel, Installation).

Automatic Transmission/Transaxle - V8 5.0L Petrol/TDV6 3.0L Diesel - Extension Housing Seal

Removal and Installation

Special Tool(s)

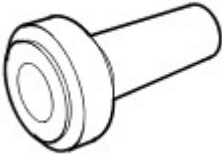
 <p>303-903 E50940</p>	<p>303-903 Remover, Input Shaft Seal</p>
 <p>307-520 E52536</p>	<p>307-520 Installer, Output Shaft Seal</p>

Removal

- 1.**  **WARNING:** Make sure to support the vehicle with axle stands.

Raise and support the vehicle.

2. Remove the transfer case.

Refer to: [Transfer Case - V8 5.0L Petrol](#) (308-07B Transfer Case, Removal).

Refer to: [Transfer Case - TDV6 3.0L Diesel](#) (308-07B Transfer Case, Removal).

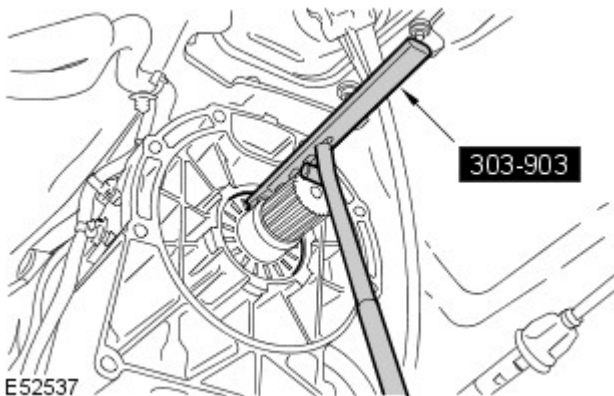

3. **3.**  **CAUTION:** Care must be taken to avoid damage to the seal register and running surface.

- Remove the transmission output shaft oil seal.
- Use the special tool.
- *Special Tool(s):* [303-903](#)

Installation

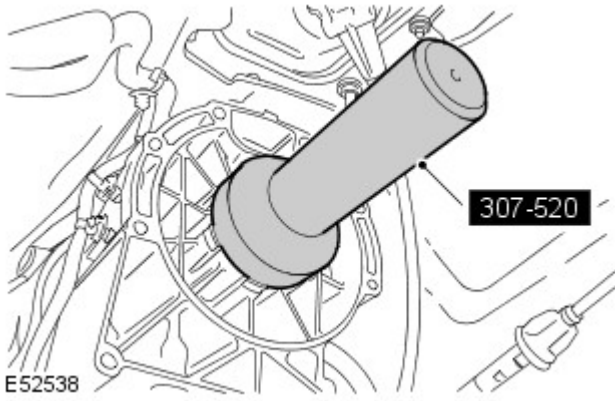

1. **1. CAUTIONS:**

 Oil seals must be fitted dry.

 Make sure that the mating faces are clean and free of foreign material.

- Install a new transmission output shaft oil seal.
- Clean the seal register.
- Use the special tool.
- *Special Tool(s):* [307-520](#)

2. Install the transfer case.

Refer to: [Transfer Case - V8 5.0L Petrol](#) (308-07B Transfer Case, Removal).

Refer to: [Transfer Case - TDV6 3.0L Diesel](#) (308-07B Transfer Case, Removal).

3. Check and top-up the transmission fluid level.

Refer to: [Transmission Fluid Level Check](#) (307-01D Automatic Transmission/Transaxle - V8 5.0L Petrol/TDV6 3.0L Diesel, General Procedures).

Automatic Transmission/Transaxle - V8 5.0L Petrol/TDV6 3.0L Diesel - Transmission Control Module (TCM) and Main Control Valve Body

Removal and Installation

Removal

- NOTE: The transmission control module (TCM) is part of the main control valve body and cannot be serviced separately.

1.  WARNING: Make sure to support the vehicle with axle stands.

Raise and support the vehicle.

2. Refer to: [Transmission Fluid Pan, Gasket and Filter](#) (307-01D Automatic Transmission/Transaxle - V8 5.0L Petrol/TDV6 3.0L Diesel, Removal and Installation).

3.

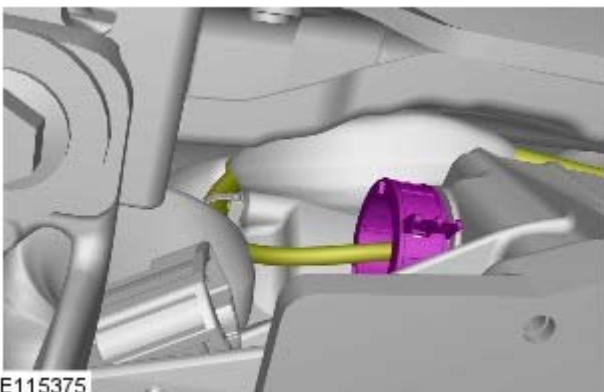

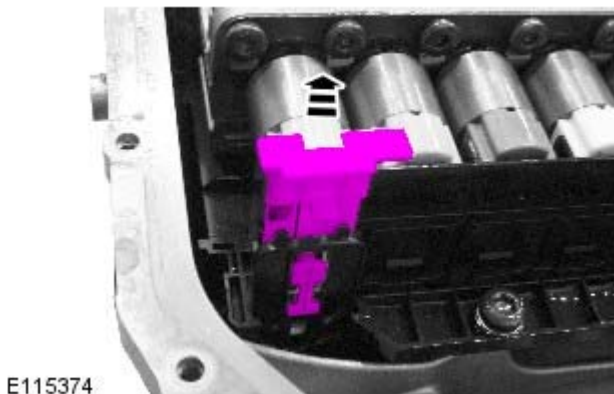

4.

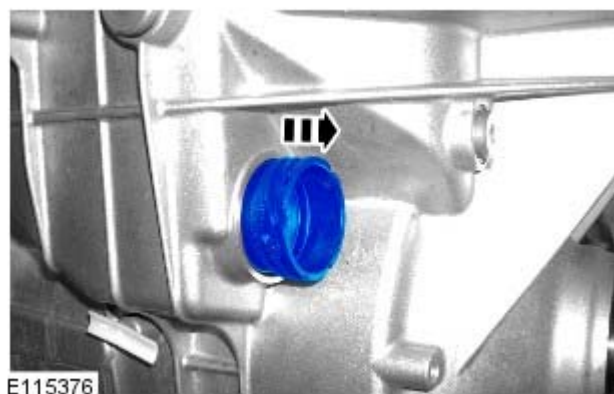

5.  CAUTION: Discard the component.

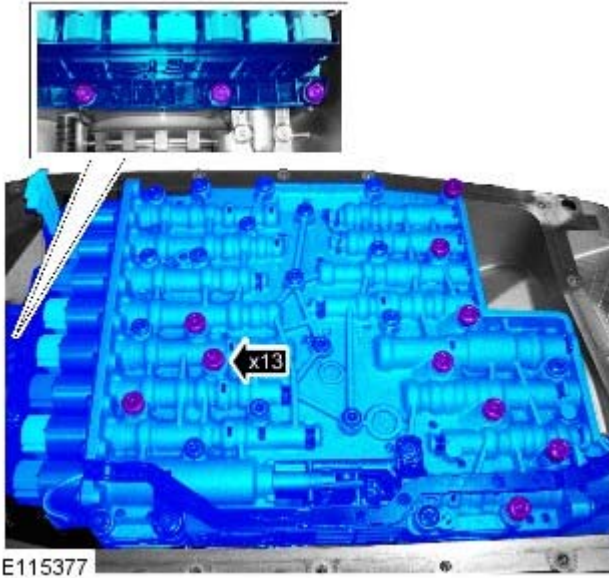



6.  CAUTION: Be prepared to collect escaping fluids.
- NOTE: Note the position of the manual park brake release.

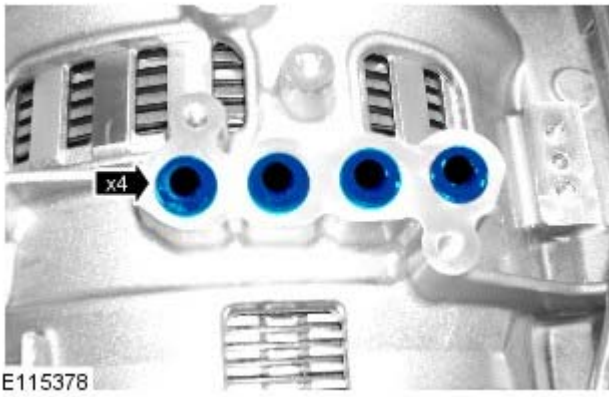

7.





8.

Installation



1. **1. CAUTIONS:**

 Make sure that when fully fitted, all seals protrude by the same amount.

 Install the new seals.

- Install a new seal block.



2. **2. CAUTIONS:**

 Install the new seals.

 Make sure that when fully fitted, all seals protrude by the same amount.

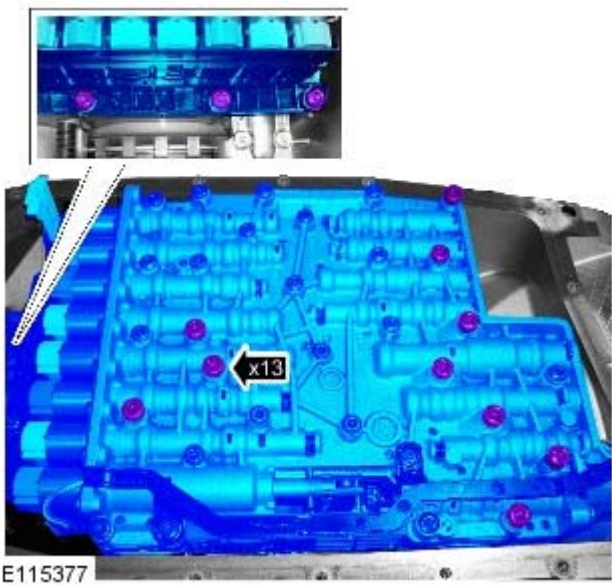

3. **3. CAUTION:** Make sure the manual park release is correctly engaged.

Torque: 8 Nm

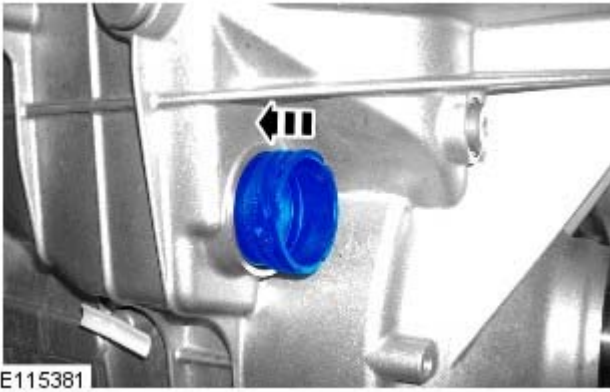

4.  CAUTION: Make sure that a new component is installed.

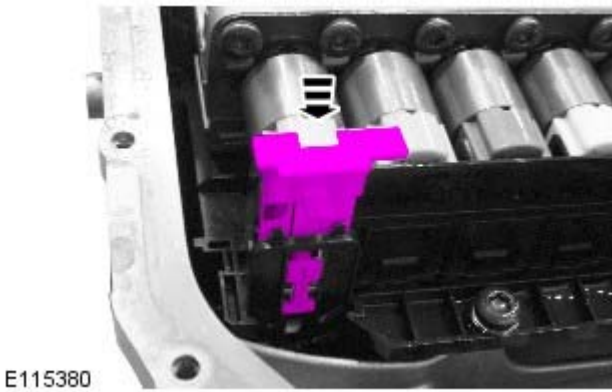

- 5.

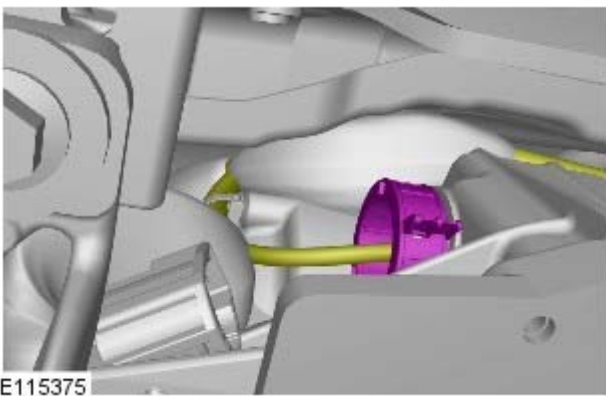

- 6.

7. Refer to: [Transmission Fluid Pan, Gasket and Filter \(307-01D Automatic Transmission/Transaxle - V8 5.0L Petrol/TDV6 3.0L Diesel, Removal and Installation\)](#).

8. If a new component has been installed, configure using Jaguar approved diagnostic equipment.

Automatic Transmission/Transaxle - V8 5.0L Petrol/TDV6 3.0L Diesel - Transmission Fluid Pan, Gasket and Filter

Removal and Installation

Removal

- NOTE: Removal steps in this procedure may contain installation details.

1.  **WARNING:** Make sure to support the vehicle with axle stands.
Raise and support the vehicle.
2. Refer to: [Transmission Fluid Drain and Refill](#) (307-01D Automatic Transmission/Transaxle - V8 5.0L Petrol/TDV6 3.0L Diesel, General Procedures).
3. Refer to: [Transmission Support Crossmember - V8 5.0L Petrol](#) (502-02 Full Frame and Body Mounting, Removal and Installation).



4.



5.

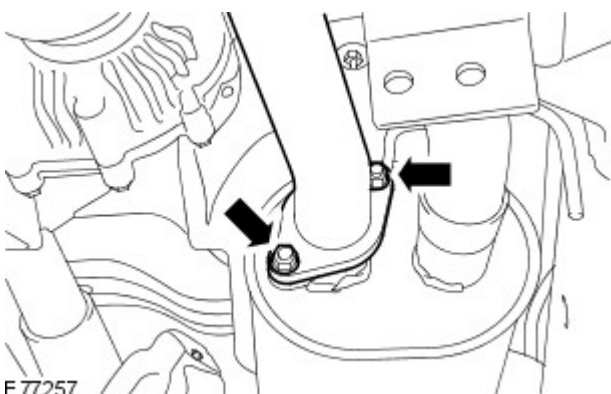

6.

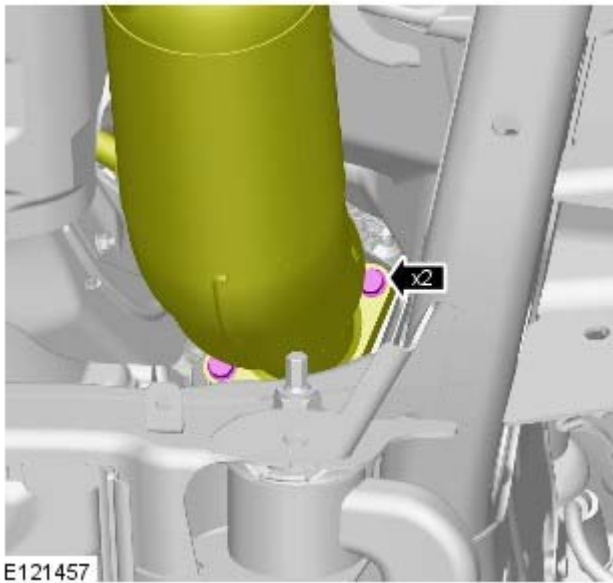

7. **7.** NOTE: Install a new gasket.

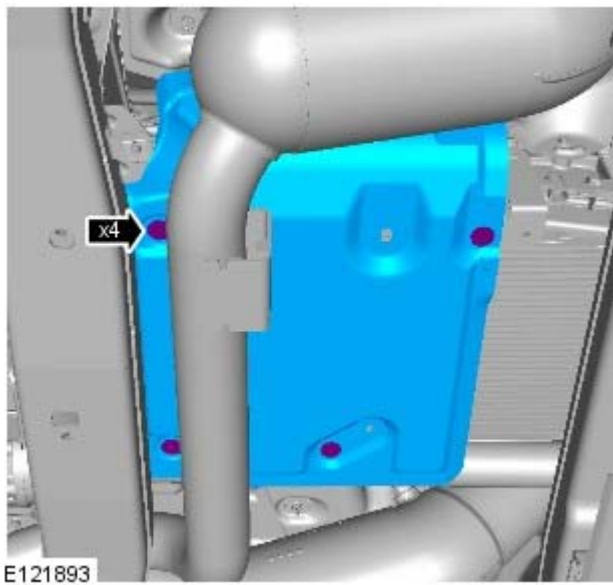

8.

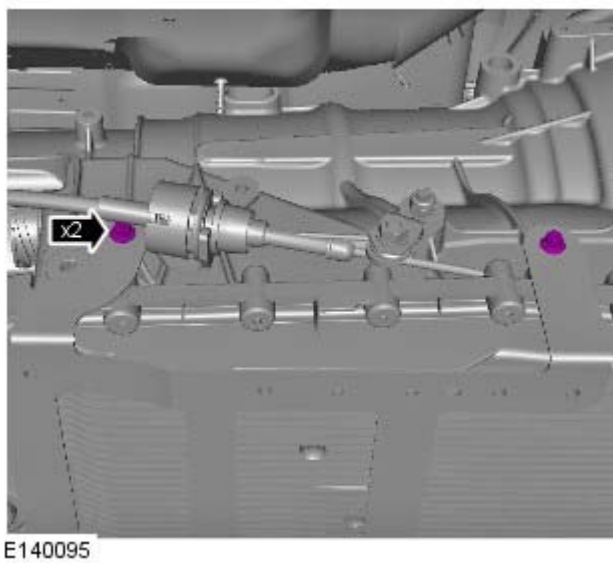

9.

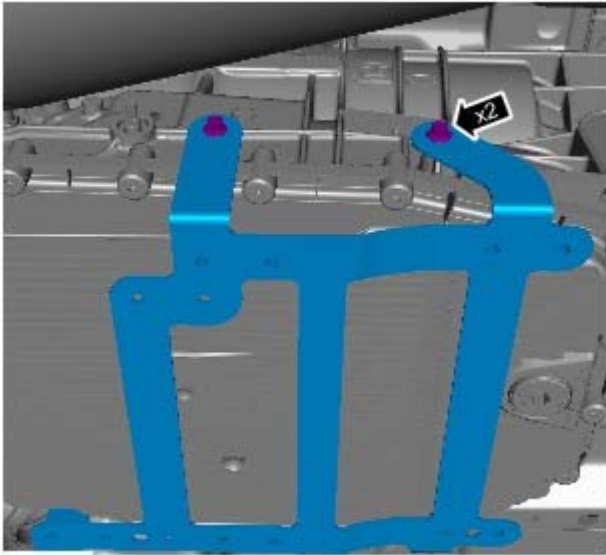

E140096

10.

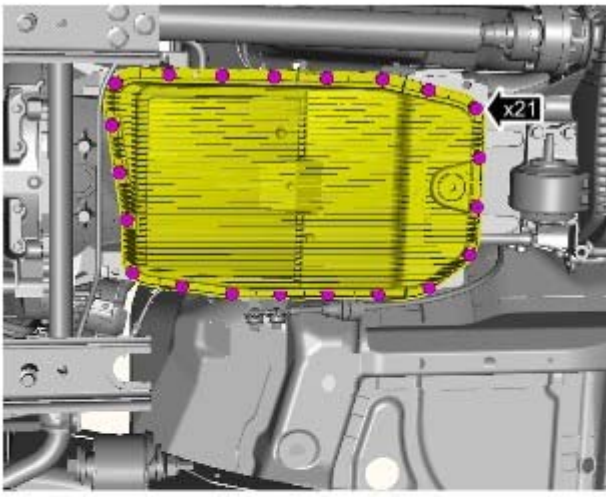

E 141086

11. **11.**  CAUTION: Be prepared to collect escaping fluids.

- NOTE: The component cannot be removed at this stage.

Detach the transmission fluid pan from the transmission.



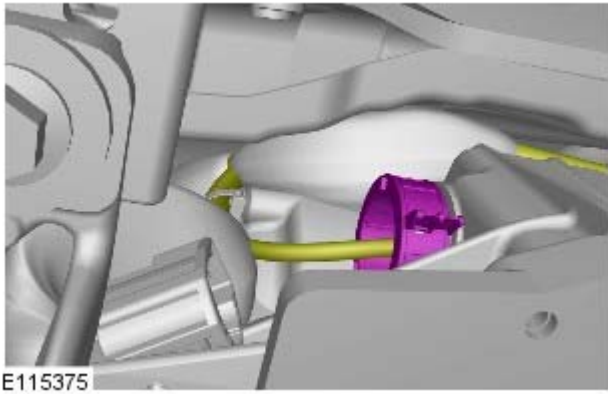

E115375

12.

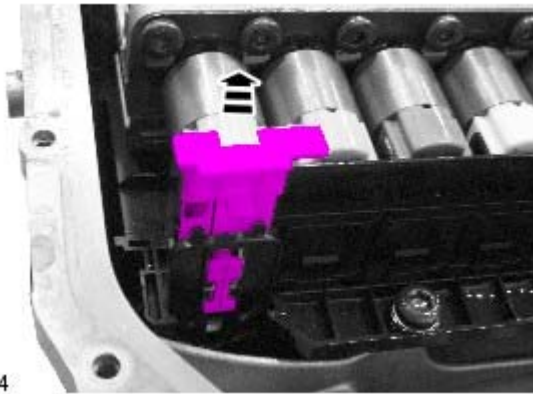

E115374

13.

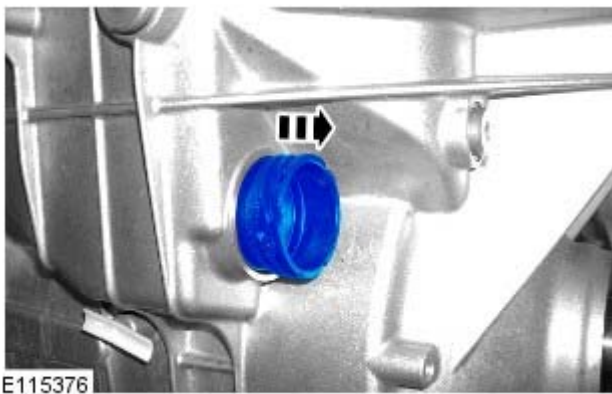

E115376

14. **14.**  CAUTION: Discard the component.

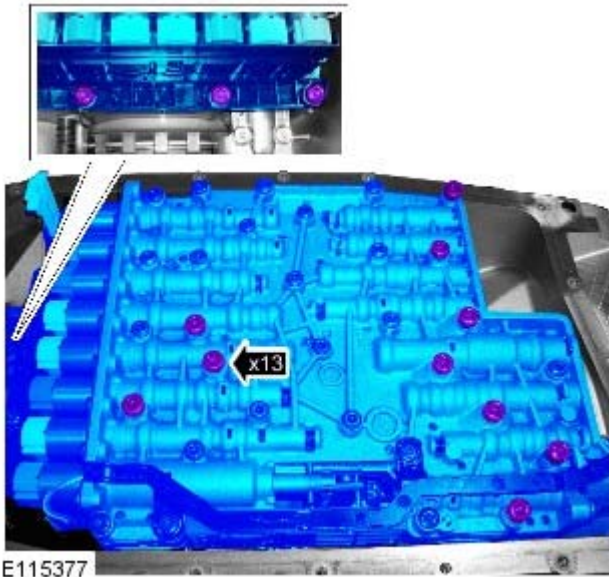

15. **15.**  **CAUTION:** Be prepared to collect escaping fluids.
- **NOTE:** Note the position of the manual park brake release.
 - **NOTE:** Transmission fluid pan shown removed for clarity.

Remove the transmission control module and the transmission fluid pan.



16.



17.

18. Remove the transmission fluid pan and the transmission control module.

19. Remove and discard the gasket.

Installation



1. **1. CAUTIONS:**

 Make sure that when fully fitted, all seals protrude by the same amount.

 Install the new seals.

- Install a new seal block.

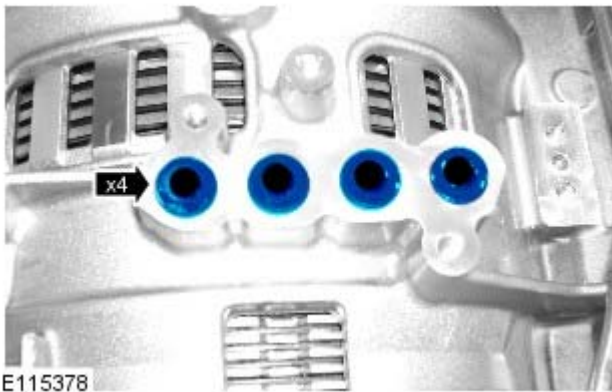

2. **2. CAUTIONS:**

 Install the new seals.

 Make sure that when fully fitted, all seals protrude by the same amount.

3. Install the new gasket.

4. Install the transmission fluid pan and the transmission control module.

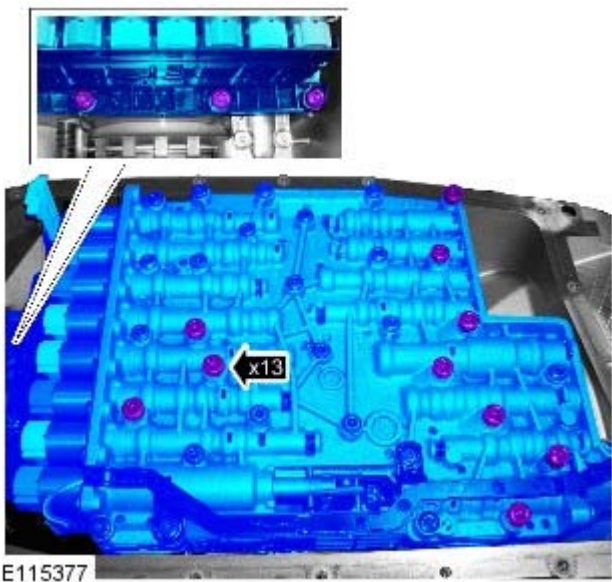

5.  **CAUTION:** Make sure the manual park release is correctly engaged.

- **NOTE:** Transmission fluid pan shown removed for clarity.

Tighten to 8 Nm.

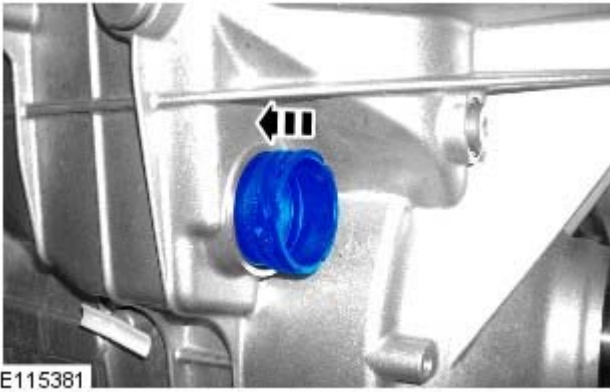

6.  CAUTION: Make sure that a new component is installed.

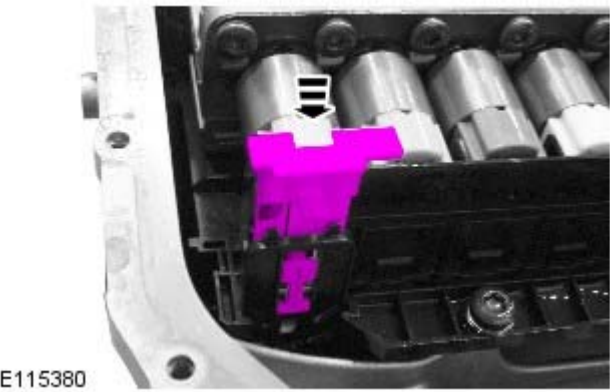

7.

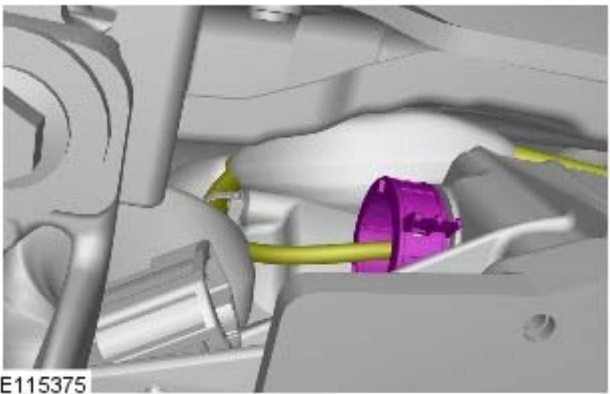

8.

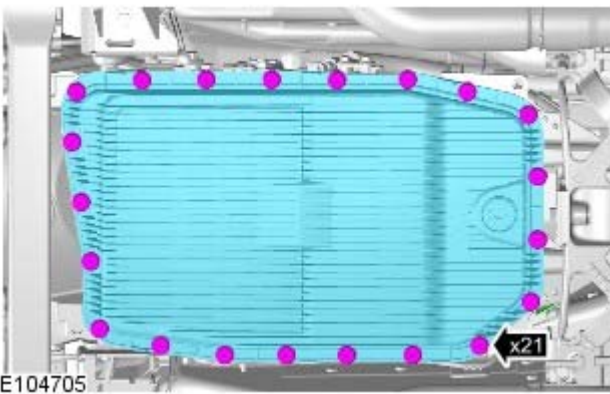

9. Tighten to 8 Nm.

10.

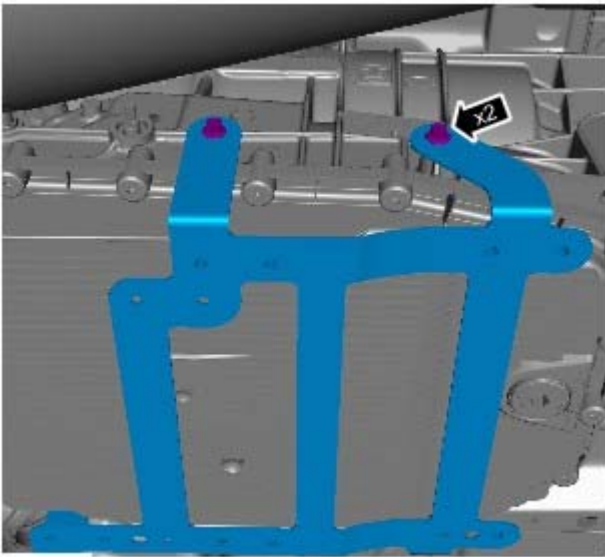

E140096

11.

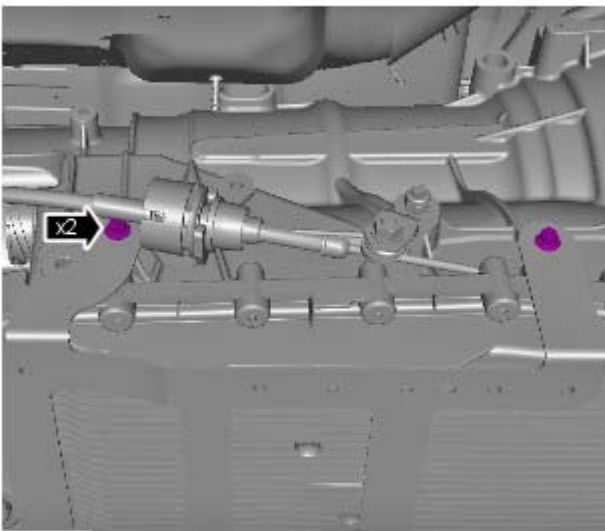

E140095

12.

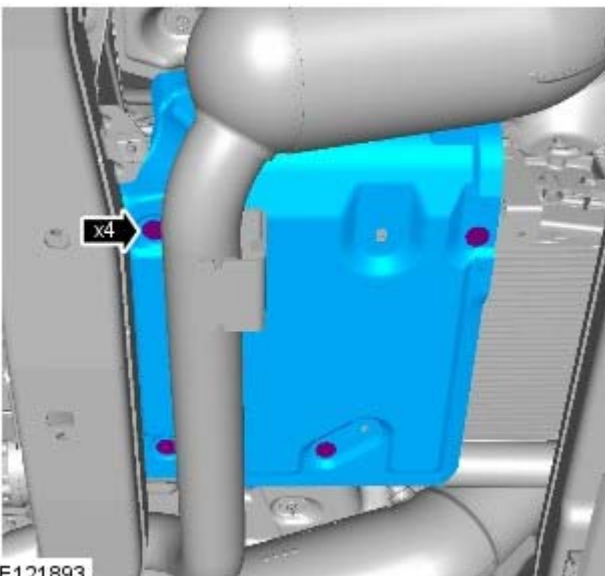

E121893

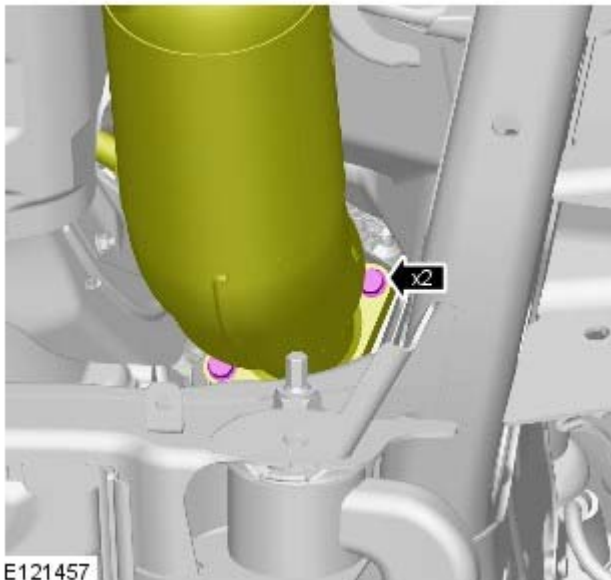

E121457

13. **13.** NOTE: Install a new gasket.

Tighten to 22 Nm.

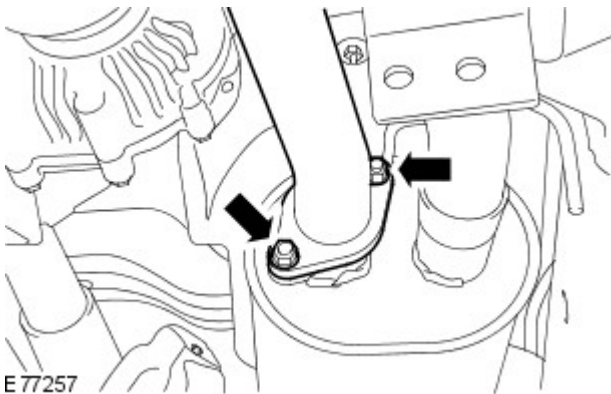

E 77257

14. Tighten to 22 Nm.



E44432

15.



E44431

17. Refer to: [16 Transmission Support Crossmember - V8 5.0L Petrol](#) (502-02 Full Frame and Body Mounting, Removal and Installation).

18. Refer to: [Transmission Fluid Drain and Refill](#) (307-01D Automatic Transmission/Transaxle - V8 5.0L Petrol/TDV6 3.0L Diesel, General Procedures).

19. Lower the vehicle.

Automatic Transmission/Transaxle - V8 5.0L Petrol/TDV6 3.0L Diesel - Transmission Support Insulator

Removal and Installation

Removal

-  **WARNING:** Make sure to support the vehicle with axle stands.

Raise and support the vehicle.

- Remove the transmission crossmember.
For additional information, refer to: [Transmission Support Crossmember - V8 5.0L Petrol](#) (502-02 Full Frame and Body Mounting, Removal and Installation) / [Transmission Support Crossmember - TDV6 3.0L Diesel](#) (502-02 Full Frame and Body Mounting, Removal and Installation).
- Remove the transmission support insulator.
 - Remove the 4 bolts.

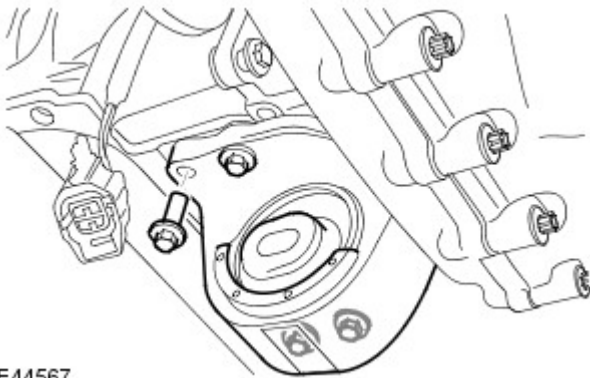

E44567

Installation

- To install, reverse the removal procedure.
 - Clean the component mating faces.
 - Tighten the bolts to 60 Nm (44 lb.ft).

Automatic Transmission/Transaxle - V8 5.0L Petrol/TDV6 3.0L Diesel - Transmission V8 5.0L Petrol

Removal

- NOTE: Some variation in the illustrations may occur, but the essential information is always correct.
- NOTE: Some illustrations may show the transmission removed for clarity.
- NOTE: Some illustrations may show the engine removed for clarity.

1. Remove the battery.

Refer to: [Battery](#) (414-01 Battery, Mounting and Cables, Removal and Installation).

2.  **WARNING:** Make sure to support the vehicle with axle stands.

Raise and support the vehicle.

3. Refer to: [Rear Driveshaft](#) (205-01 Driveshaft, Removal and Installation).
4. Refer to: [Exhaust System](#) (309-00D Exhaust System - V8 5.0L Petrol, Removal and Installation).
5. Refer to: [Front Driveshaft - V8 5.0L Petrol](#) (205-01 Driveshaft, Removal and Installation).
6. Refer to: [Axle Assembly](#) (205-03 Front Drive Axle/Differential, Removal and Installation).

- 7.

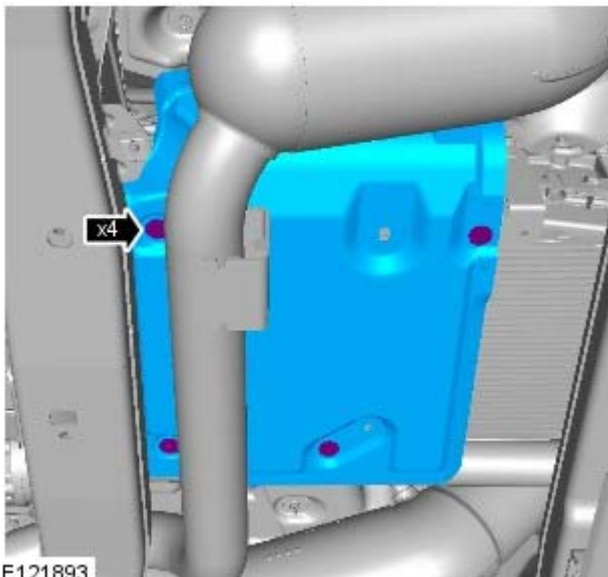

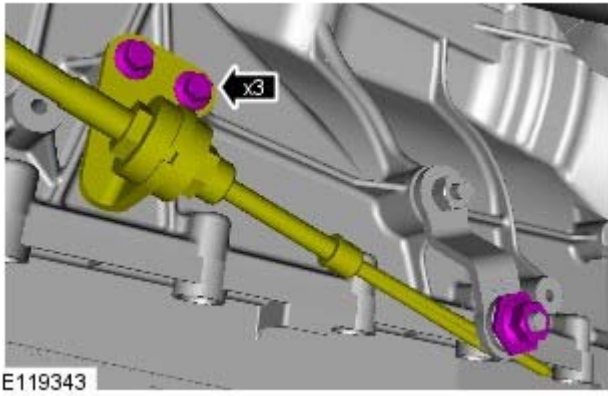

E119343

8.

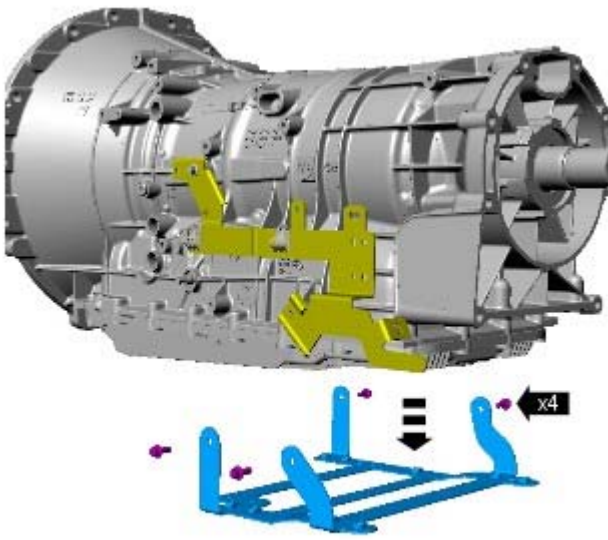

E123334

9.



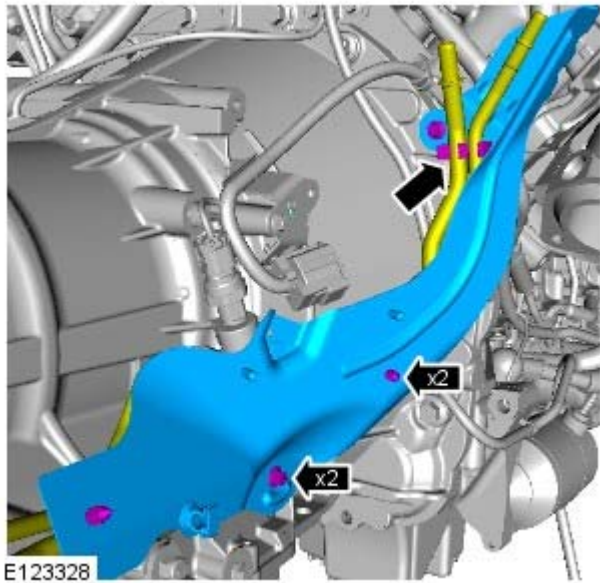

E121680

10.

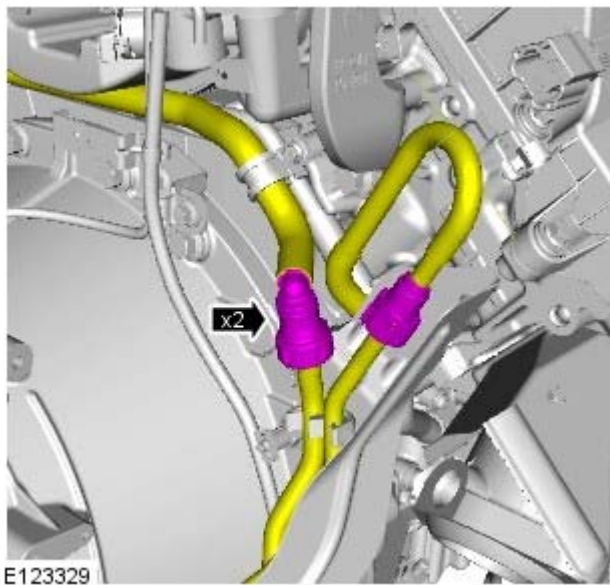

11.



12. **12.**  **WARNING:** Do not smoke or carry lighted tobacco or open flame of any type when working on or near any fuel related components. Highly flammable vapors are always present and may ignite. Failure to follow these instructions may result in personal injury.

 **CAUTION:** Be prepared to collect escaping fluids.

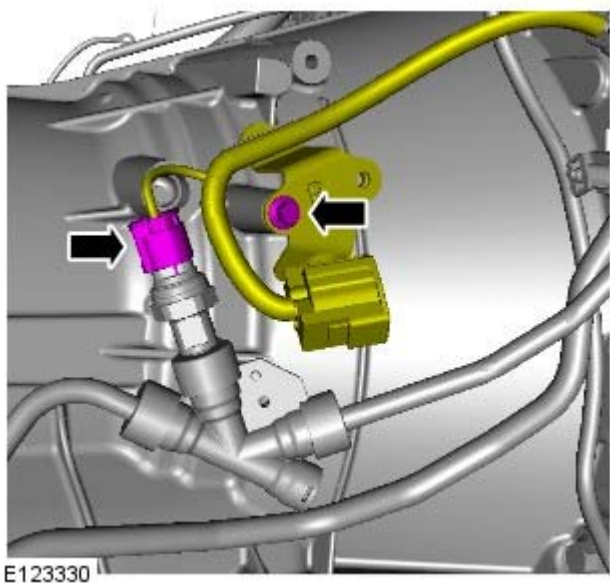

13.

14.

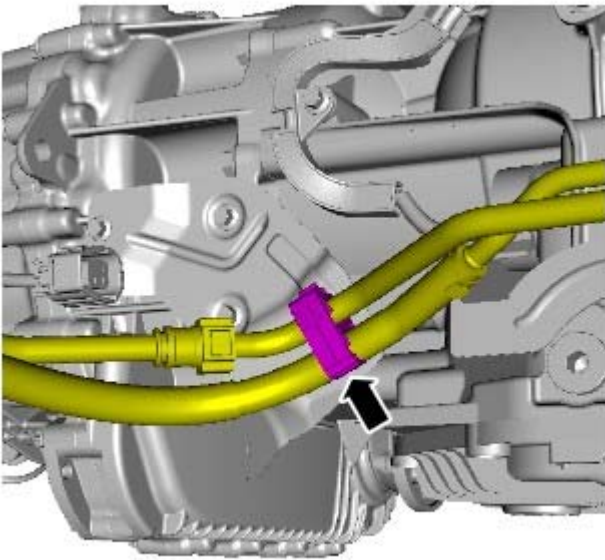

E123332

15.

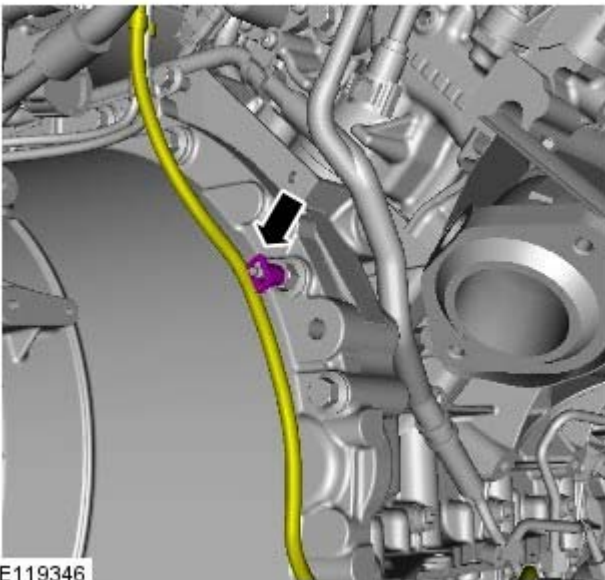

E119346

16.

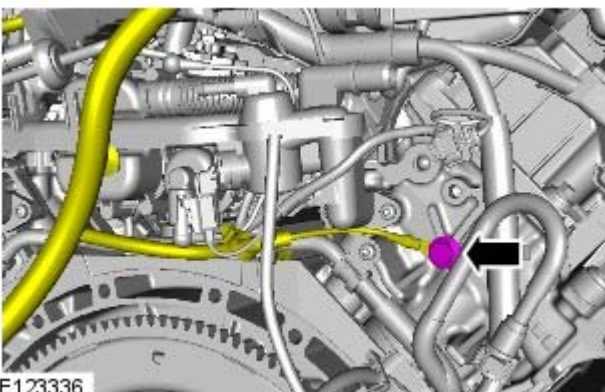

E123336

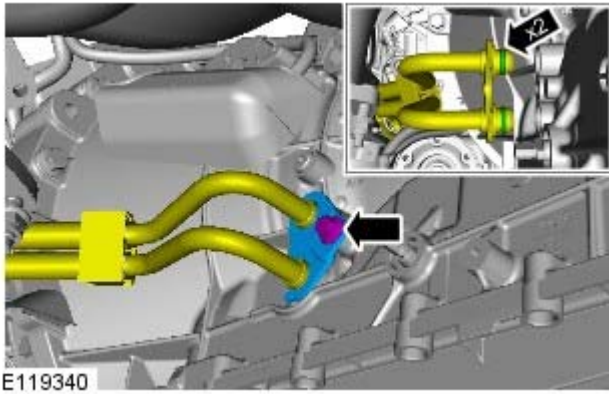

17. **17.**  **WARNING:** Be prepared to collect escaping fluids.

 **CAUTION:** Make sure that all openings are sealed. Use new blanking caps.

- Remove and discard the 2 O-ring seals.

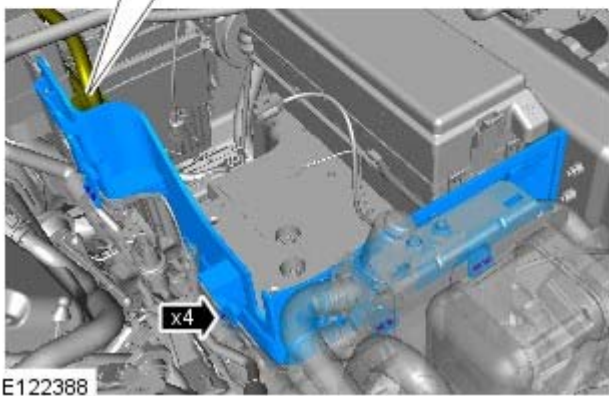
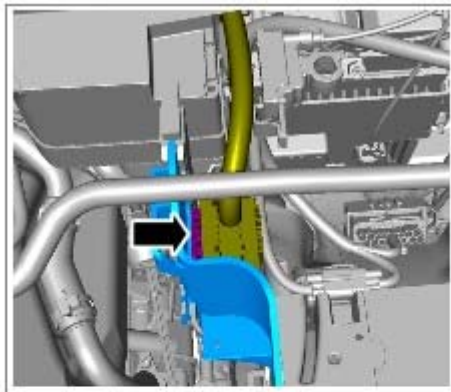

18. **18.** **NOTE:** RHD illustration shown, LHD is similar.

19.

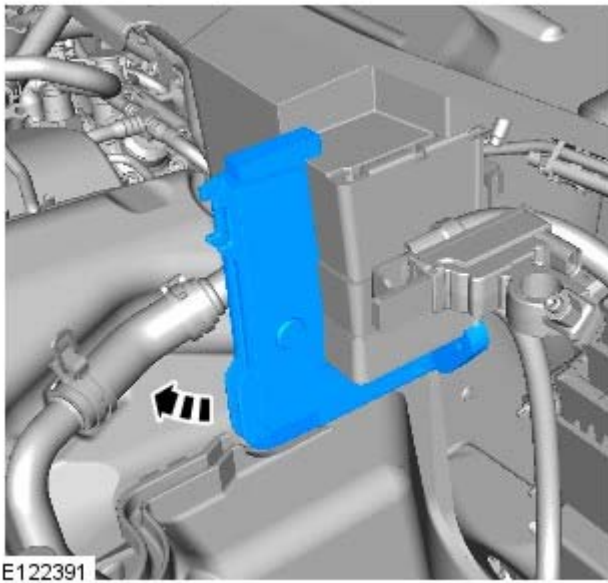

20.

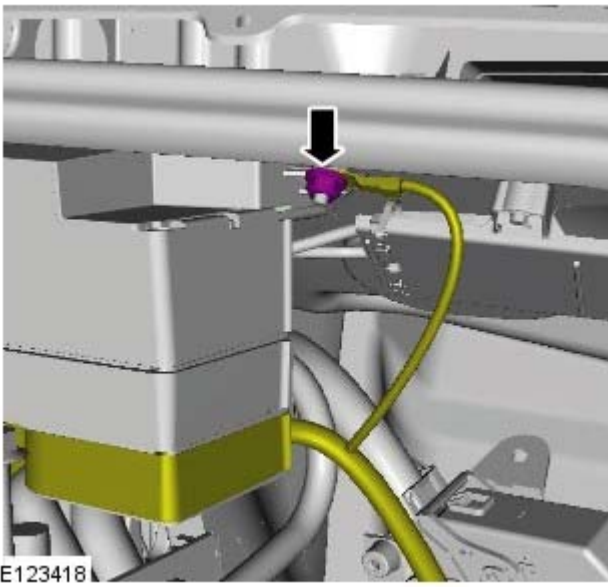

21.

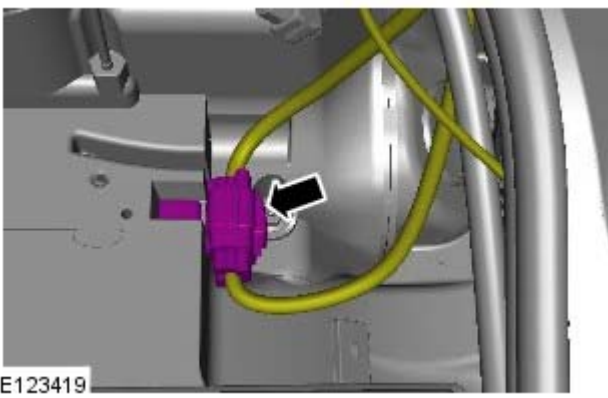



22.

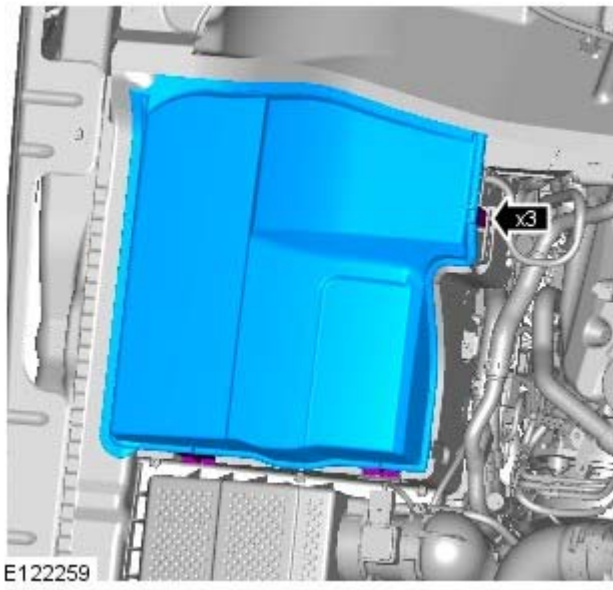

23.

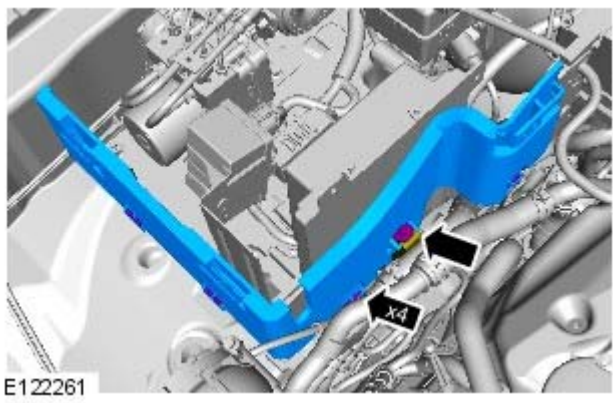

24.

25.

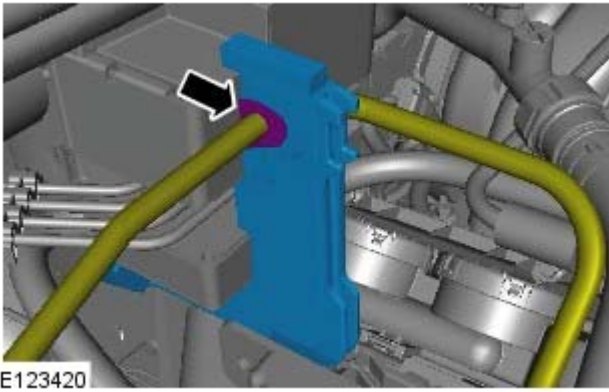

26.

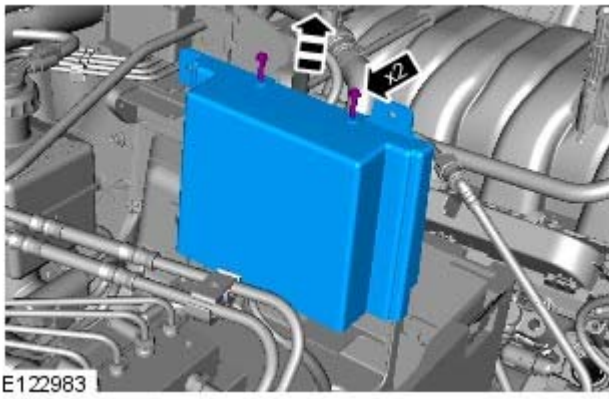

27.

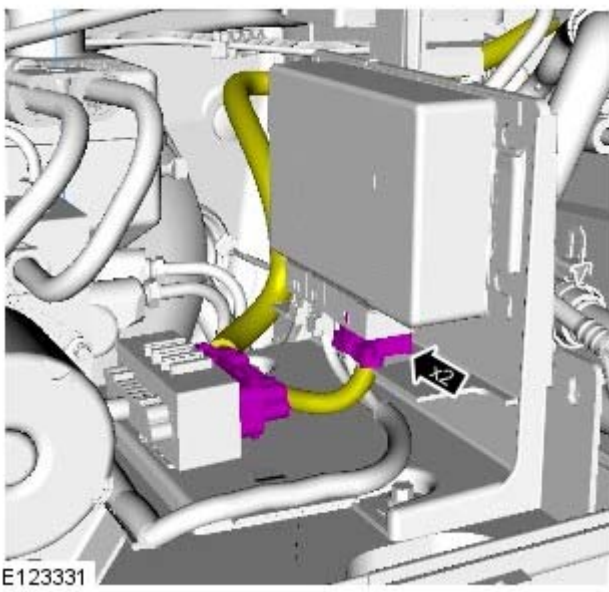

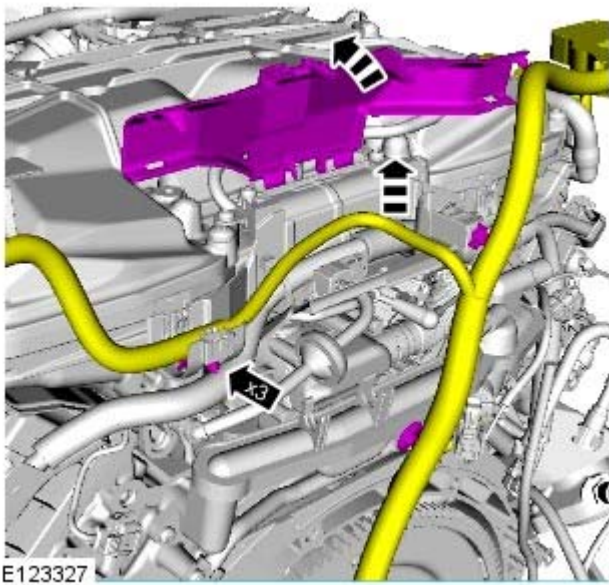

28.

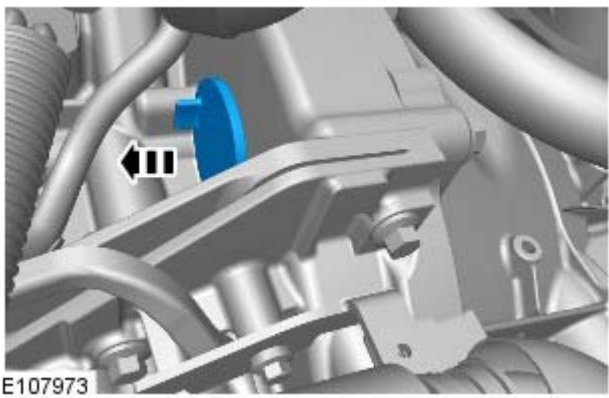

29.

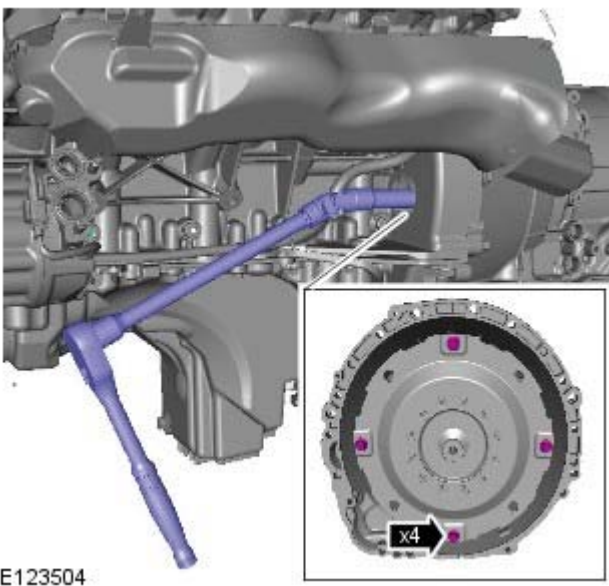

30. **30.**  **CAUTION:** Only rotate the crankshaft clockwise.

- Make sure that the alignment mark is visible through the inspection hole on removal of the last torque converter bolt.

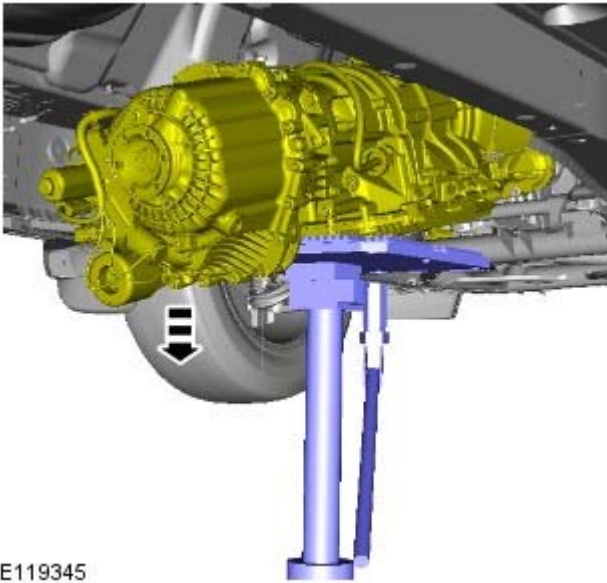

E119345

31. **31.**  **WARNING:** Make sure that the transmission is secured with suitable retaining straps.

Lower the rear of the transmission for access.

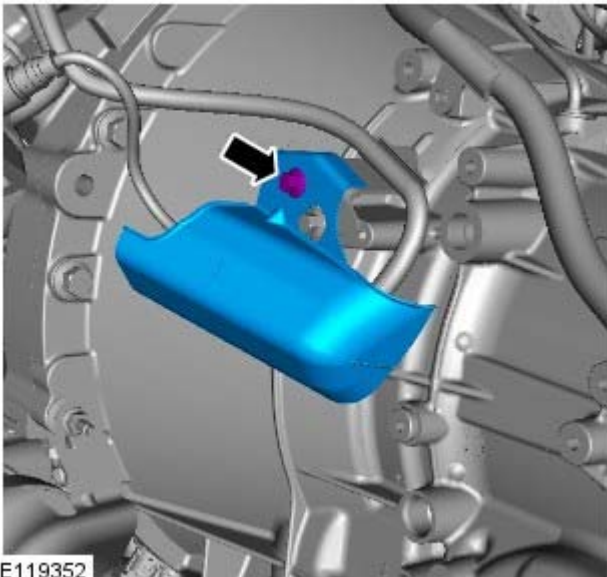

E119352

- 32.

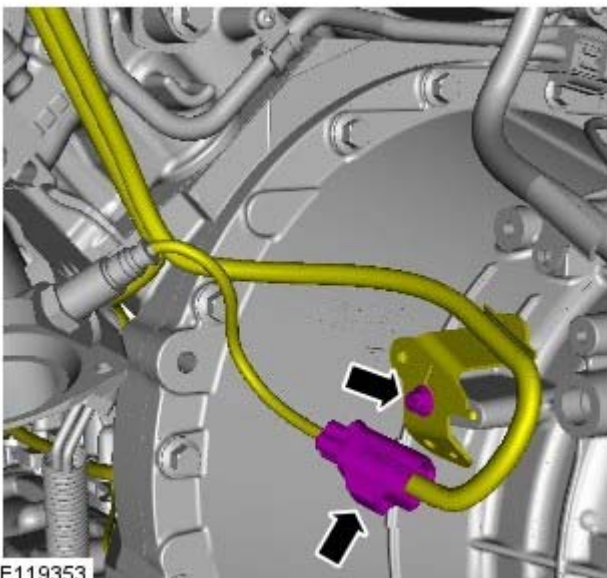

E119353

- 33.

34.

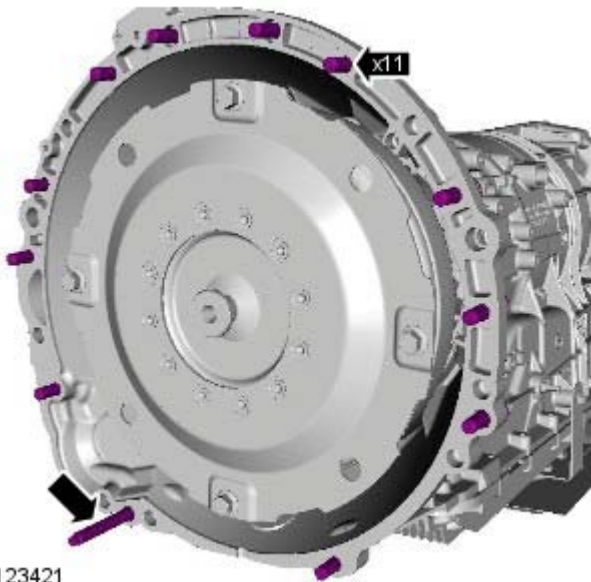

E123421

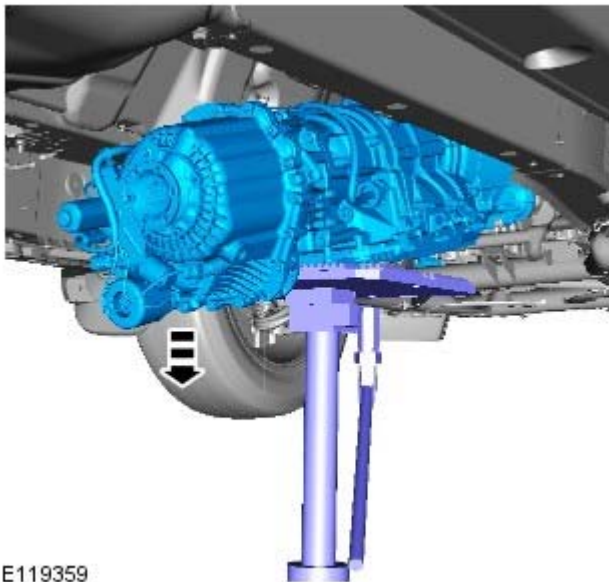

E119359

35. **35.**  **CAUTION:** Make sure that the torque converter remains in the transmission.

• **NOTE:** This step requires the aid of another technician.

- Using a suitable hydraulic jack, support the transmission.
- Do not disassemble further if removed for access only
- Install the torque converter retainer.

Automatic Transmission/Transaxle - V8 5.0L Petrol/TDV6 3.0L Diesel - TransmissionTDV6 3.0L Diesel

Removal

Special Tool(s)

 <p>303-1069 Adaptor, Wrench</p> <p>E53727</p>	<p>303-1069 Adaptor, Wrench</p>
---	-------------------------------------

- NOTE: Some variation in the illustrations may occur, but the essential information is always correct.
- NOTE: Some illustrations may show the transmission removed for clarity.
- NOTE: Some illustrations may show the engine removed for clarity.

1.
 - Disconnect the battery ground cable.
 - Refer to: Specifications (414-00, Specifications).
2.  **WARNING:** Make sure to support the vehicle with axle stands.
Raise and support the vehicle.

3.

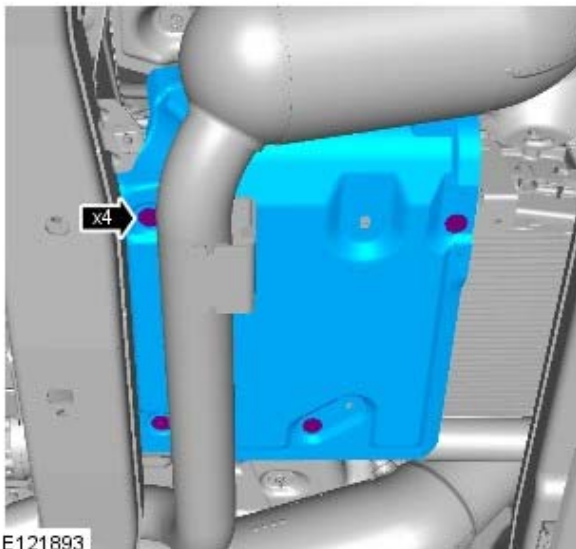

4.

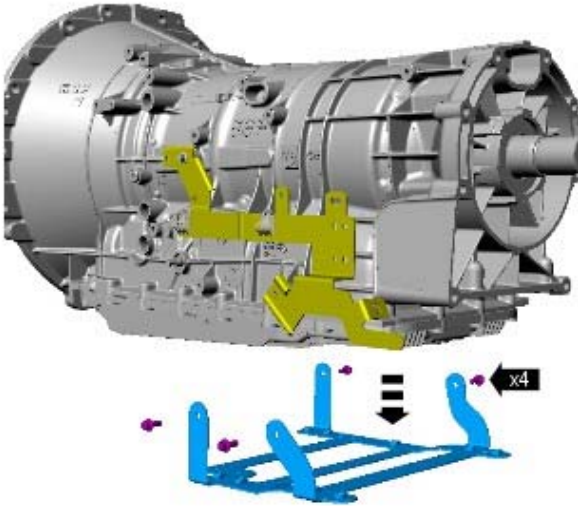

E123334

5. Refer to: [Catalytic Converter](#) (309-00B Exhaust System - TDV6 3.0L Diesel, Removal and Installation).

6. Refer to: [Rear Driveshaft](#) (205-01 Driveshaft, Removal and Installation).

7.

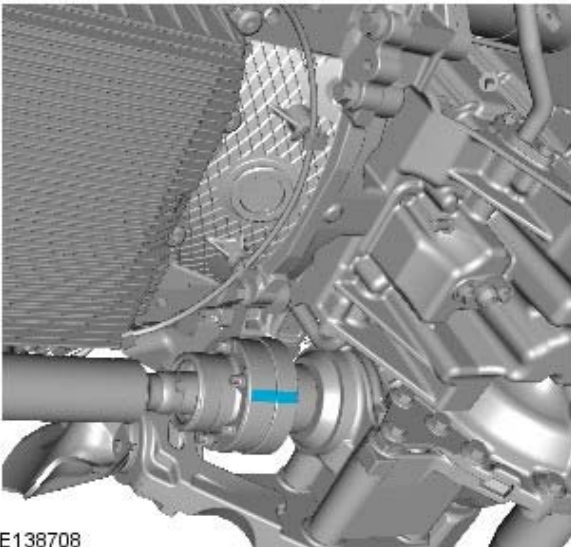

E138708

8.  **CAUTION:** Discard the bolts.

Using a suitable tie strap, secure the driveshaft.

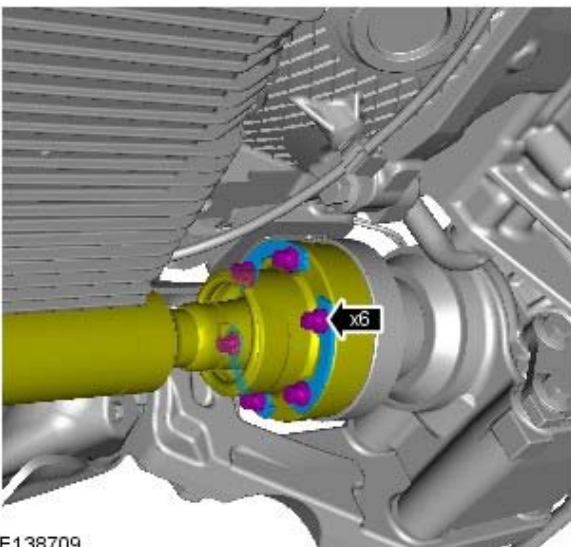

E138709

9.

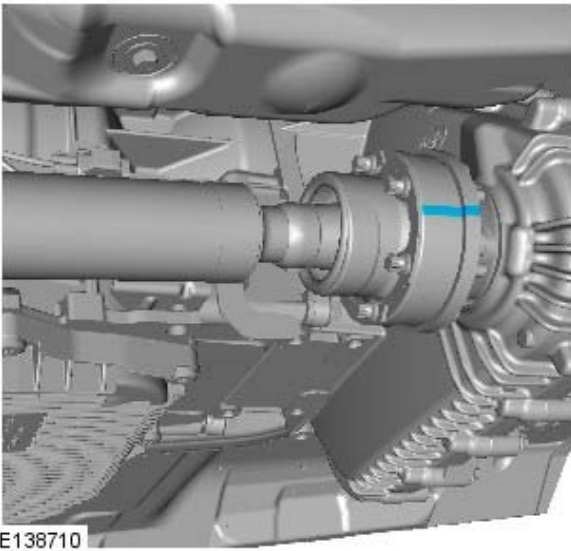

E138710

10. **10.**  CAUTION: Discard the bolts.

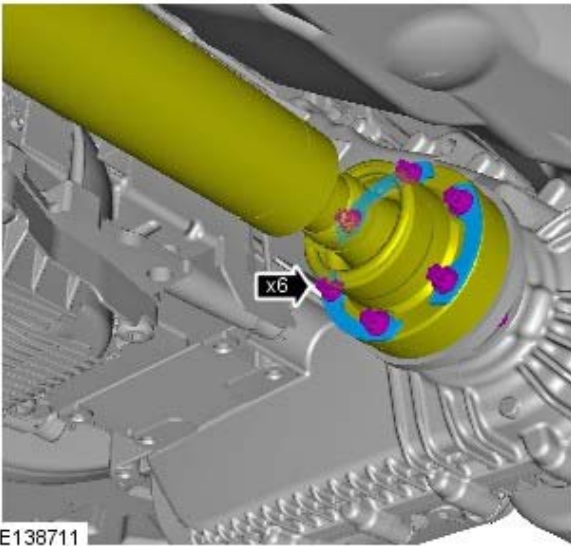

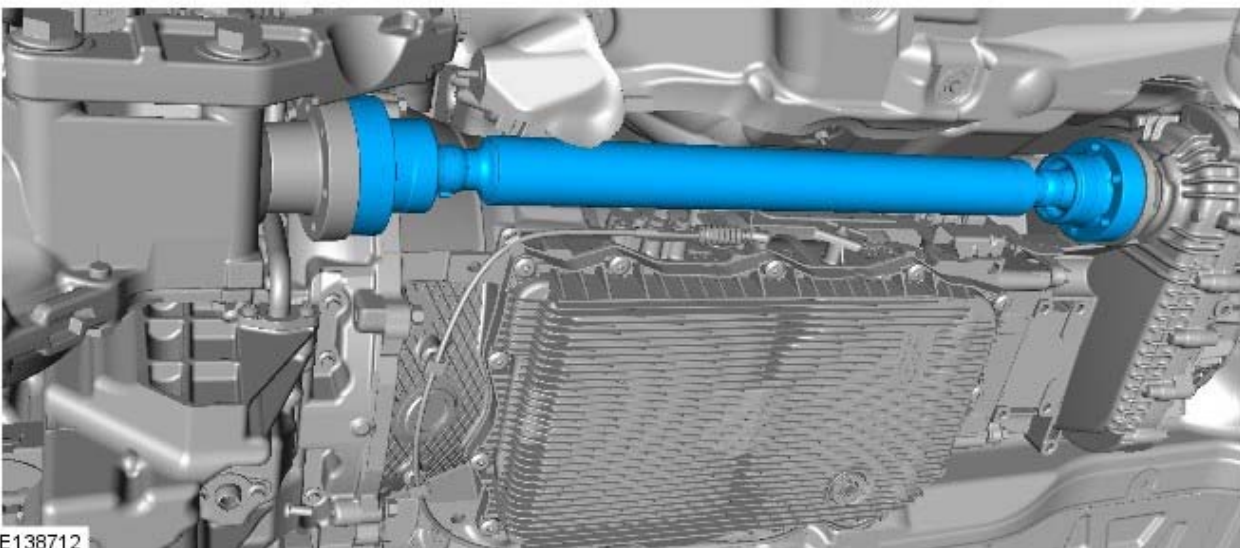

E138711

11.

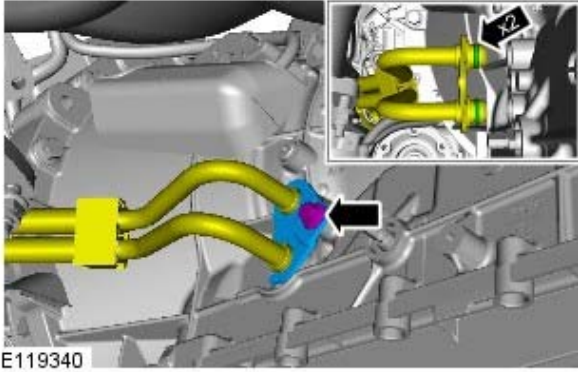

E138712



12. **12.**  **WARNING:** Be prepared to collect escaping fluids.
- **NOTE:** Make sure that all openings are sealed. Use new blanking caps.
- Remove and discard the O-ring seals.

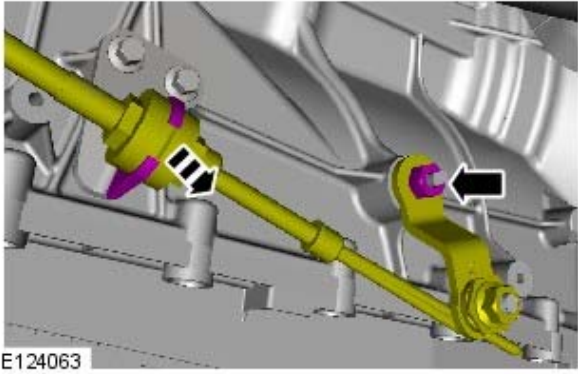

13.

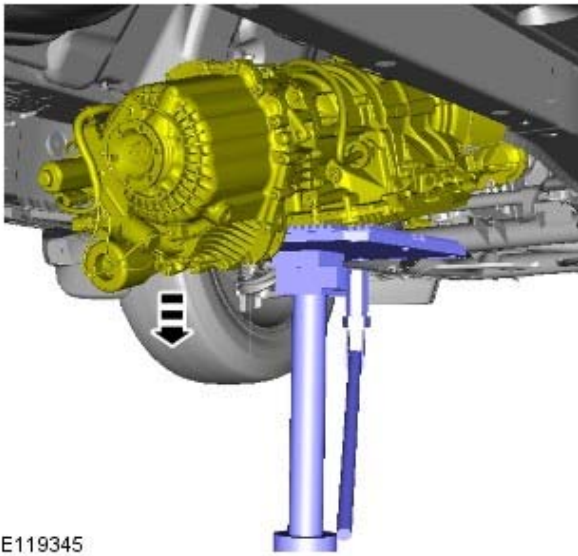

14. **14.**  **WARNING:** Make sure that the transmission is secured with suitable retaining straps.
- Lower the rear of the transmission for access.

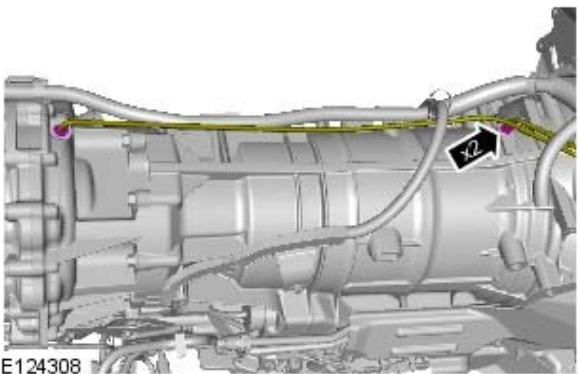

15.

16.

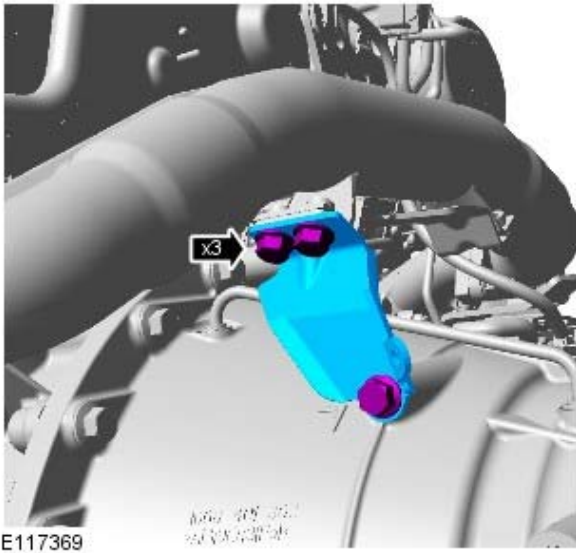

17.

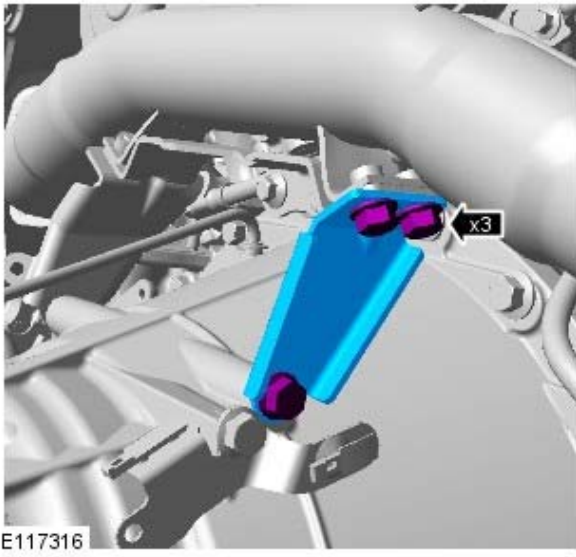

18.

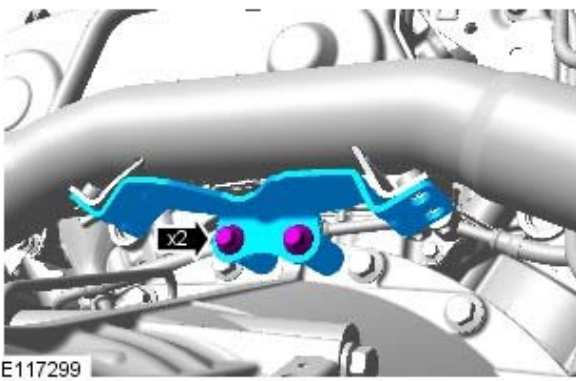

19.

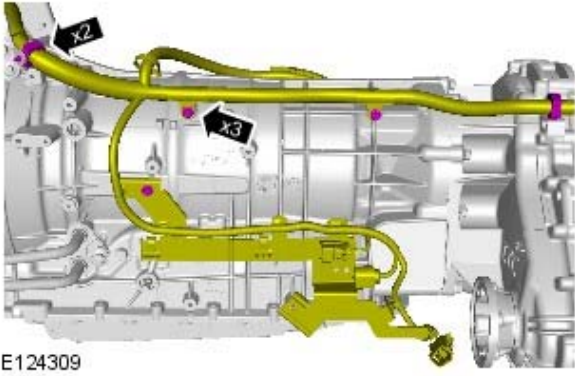

E124309

20.

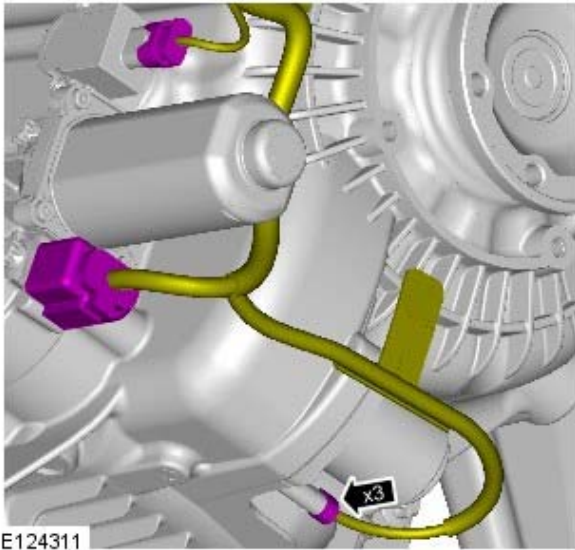

E124311

21.

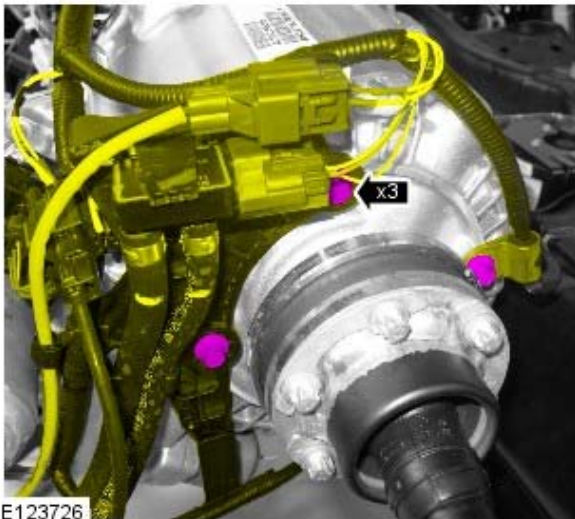

E123726

22.

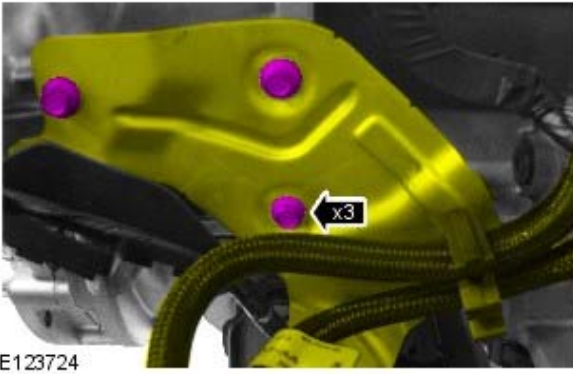

E123724

23.

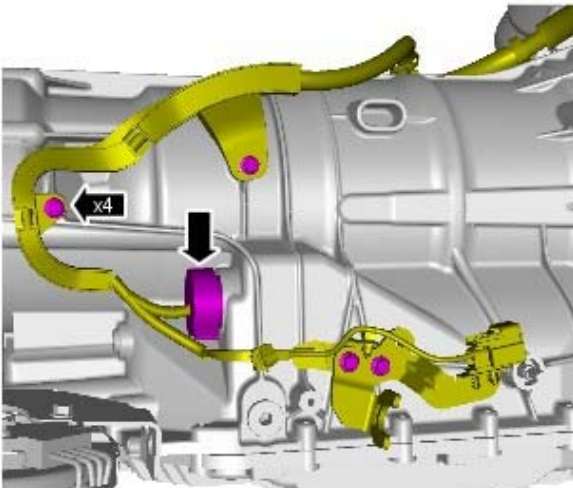

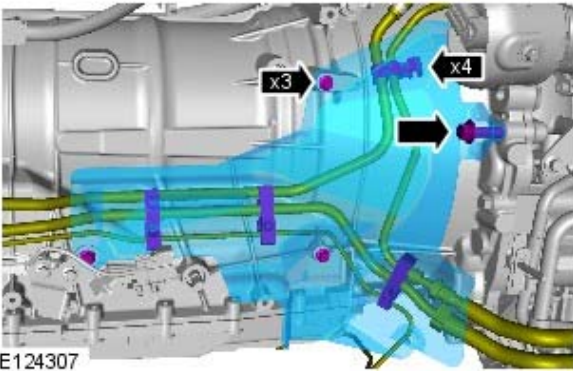

E124310

24.

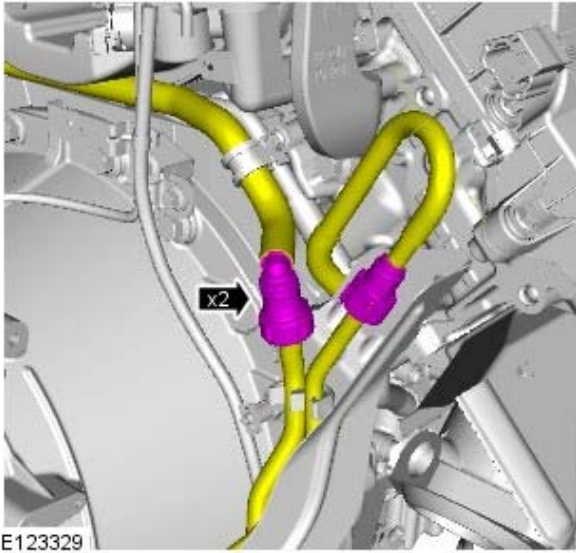

E124307



25. **25.**  **WARNING:** Do not smoke or carry lighted tobacco or open flame of any type when working on or near any fuel related components. Highly flammable vapors are always present and may ignite. Failure to follow these instructions may result in personal injury.

 **CAUTION:** Be prepared to collect escaping fluids.

- **NOTE:** Make sure that all openings are sealed. Use new blanking caps.

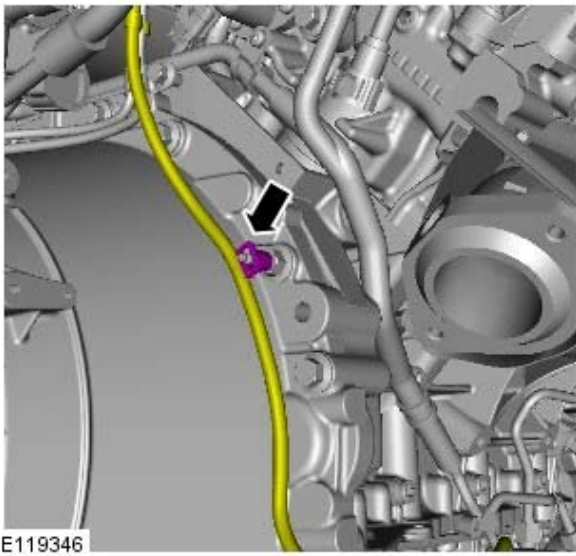

26.

27. Refer to: Starter Motor (303-06, Removal and Installation).

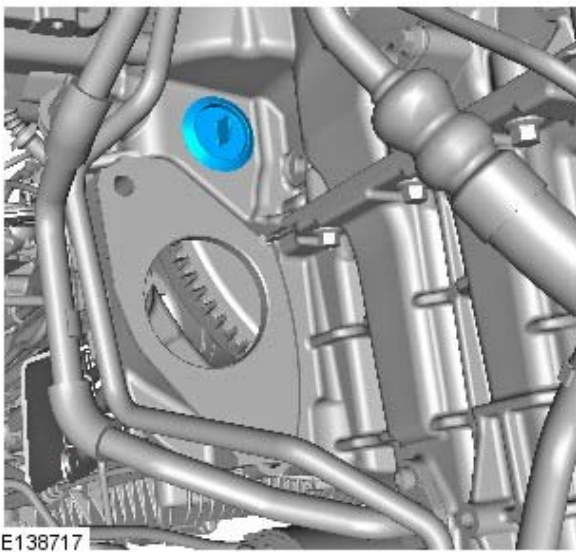

28.

29.

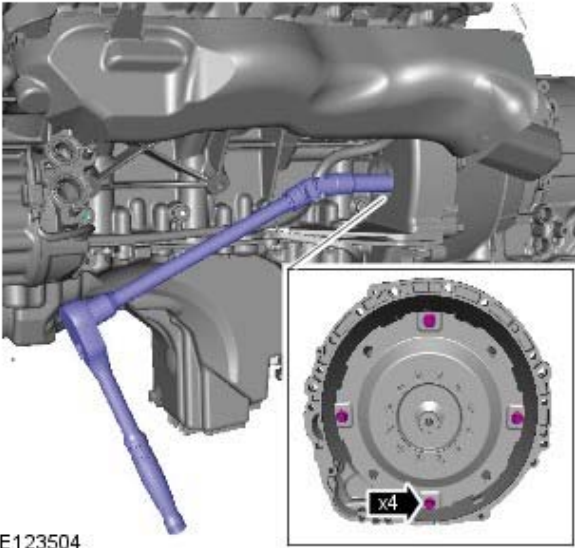

E123504

30.

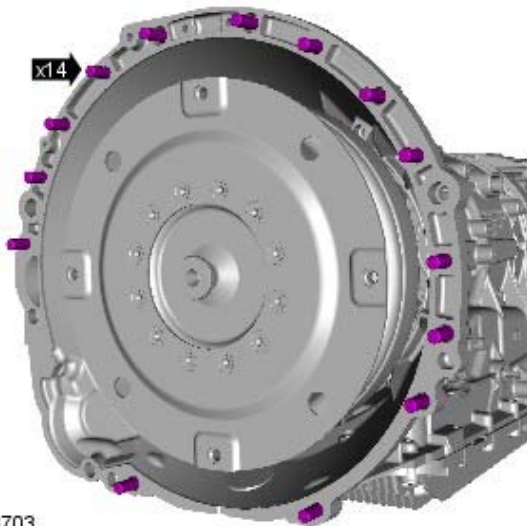

E138703

31. **31.**  CAUTION: WARNING: Make sure that the transmission is secured with suitable retaining straps.

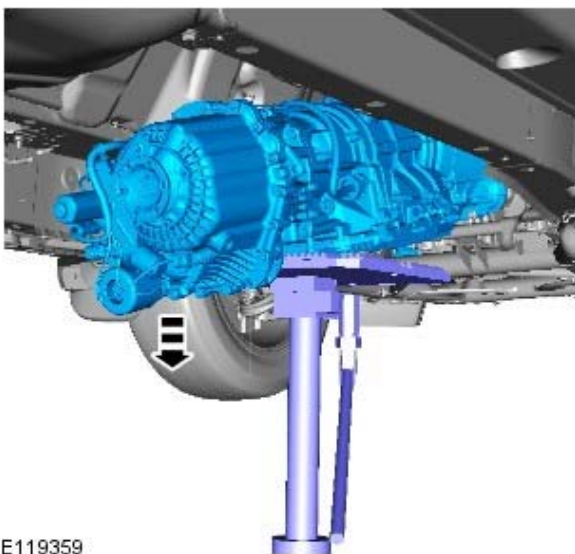

E119359

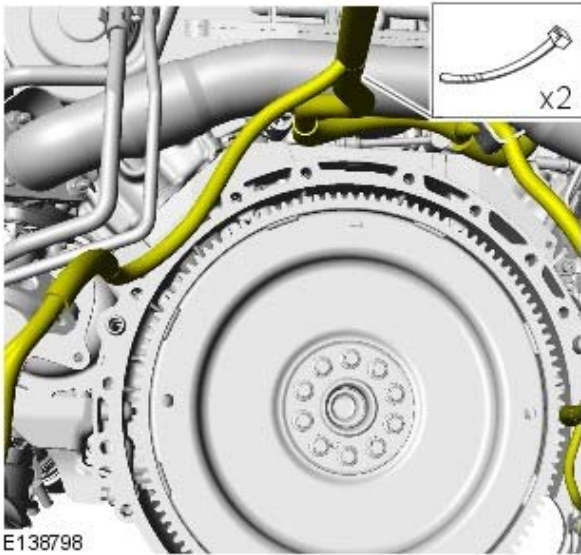

32. Carefully tie the harness aside.

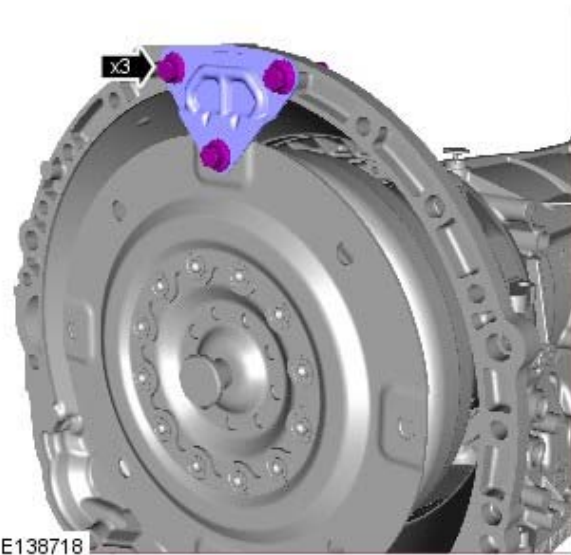

33. **33.**  CAUTION: Make sure that the torque converter remains in the transmission.

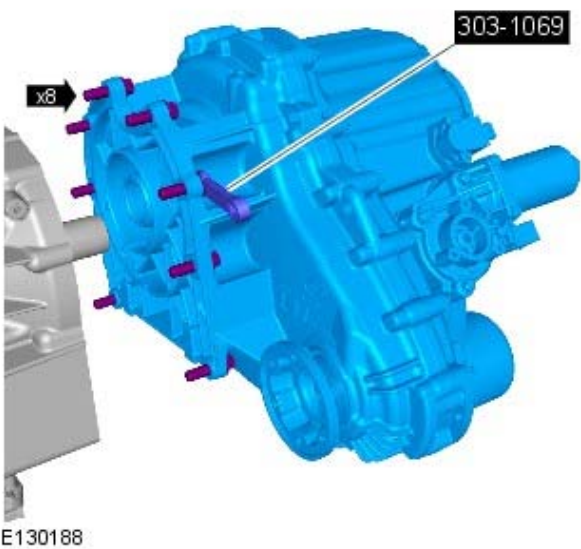

34. **34.** NOTE: Do not disassemble further if the component is removed for access only.

Special Tool(s): [303-1069](#)

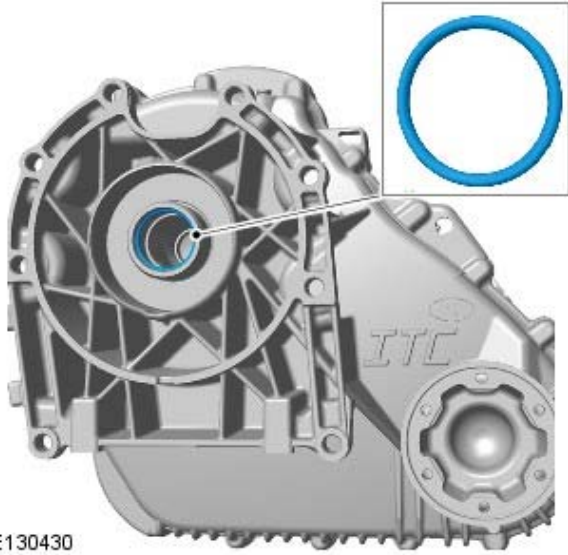

E130430

35. **35.**  **CAUTION:** Inspect the seal, replace if damaged
- **NOTE:** Remove and discard the O-ring seal.

Automatic Transmission/Transaxle - V8 5.0L Petrol/TDV6 3.0L Diesel - Transmission V8 5.0L Petrol

Installation

- NOTE: Some variation in the illustrations may occur, but the essential information is always correct.
- NOTE: Some illustrations may show the transmission removed for clarity.
- NOTE: Some illustrations may show the engine removed for clarity.

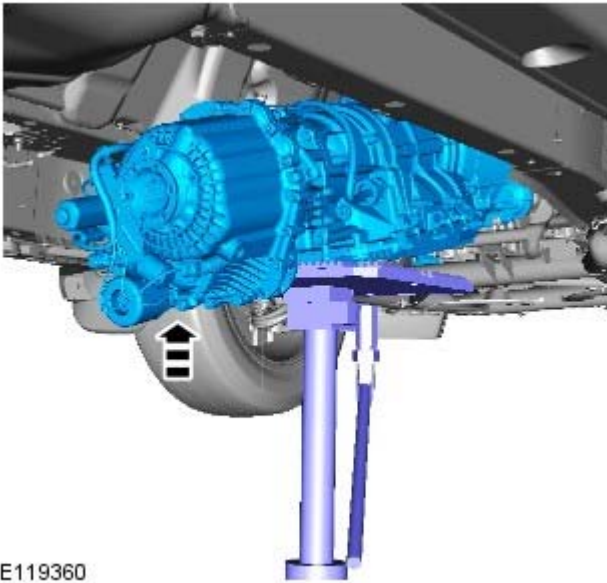

E119360

1. CAUTIONS:

 Apply grease of the correct specification to the torque converter spigot.

 Make sure the torque converter remains connected to the transmission.

With assistance, install the transmission.



E123421

2. Torque: 40 Nm

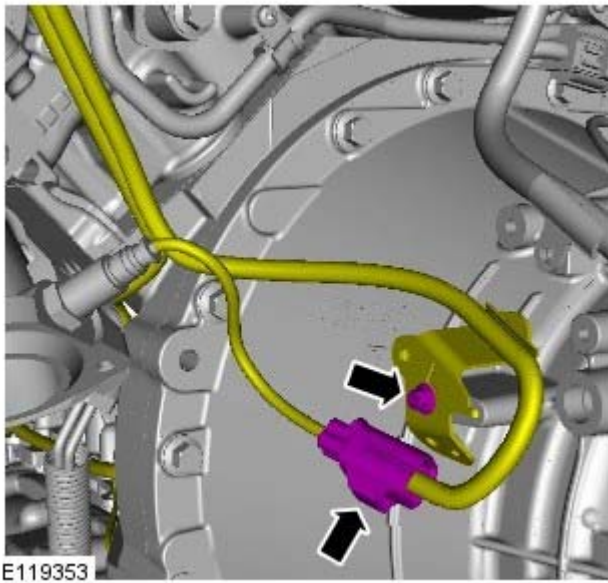

3. Torque: 10 Nm

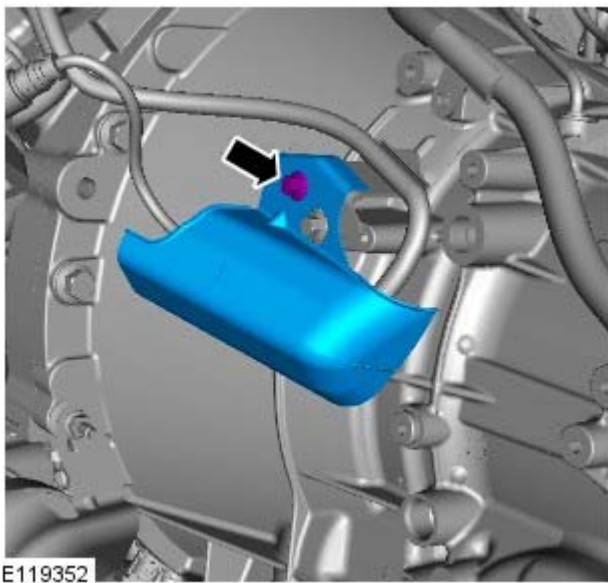

4. Torque: 10 Nm

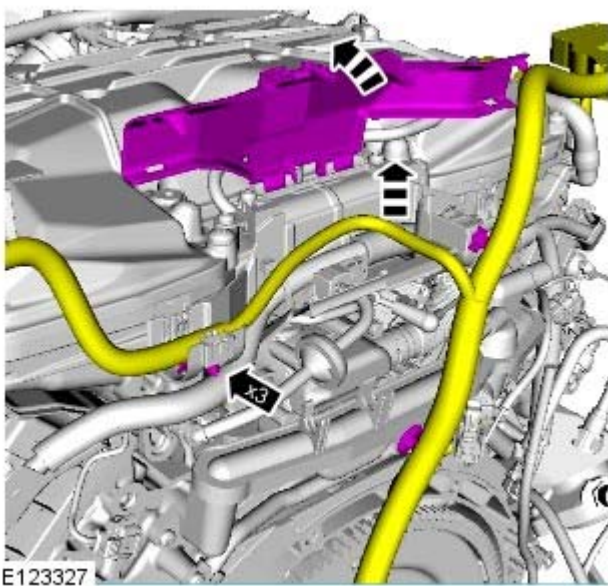

5.

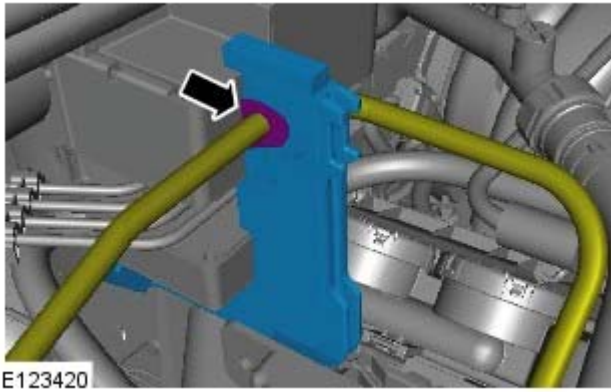

6.

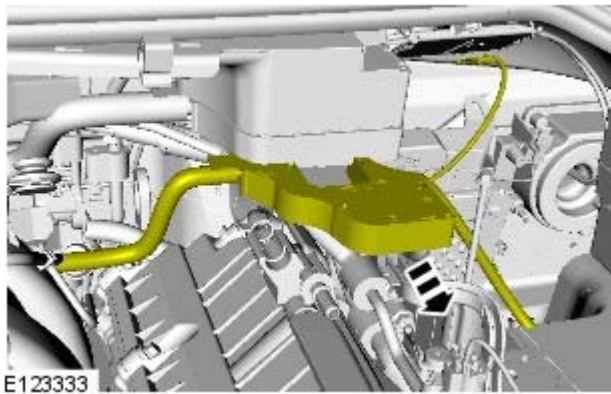

7.

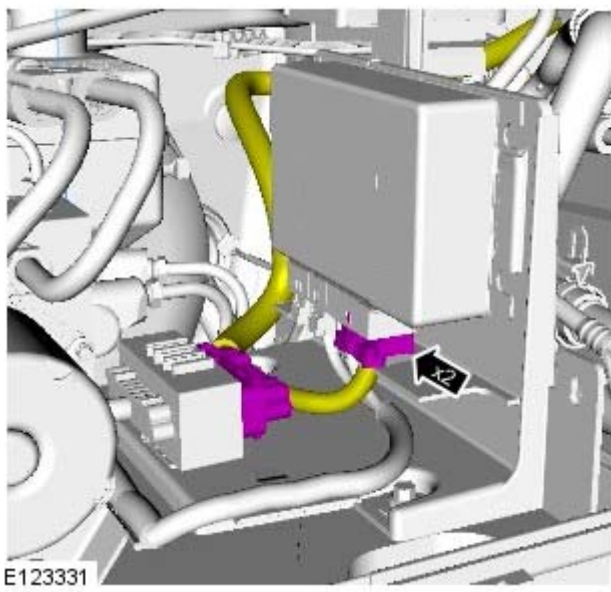

8.

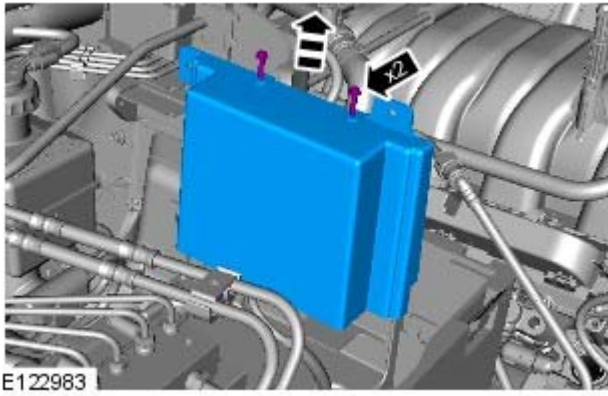

9. Torque: 3 Nm

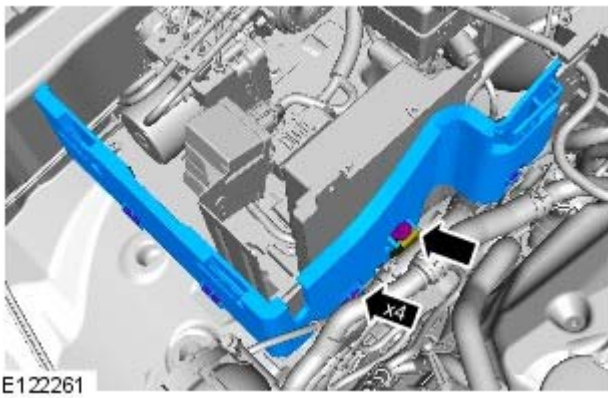

10. Torque: 9 Nm

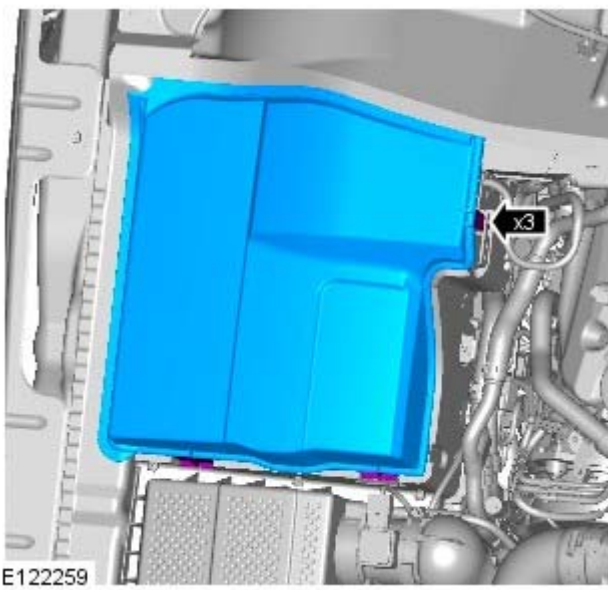

11. **11.** NOTE: RHD illustration shown, LHD is similar.

12.

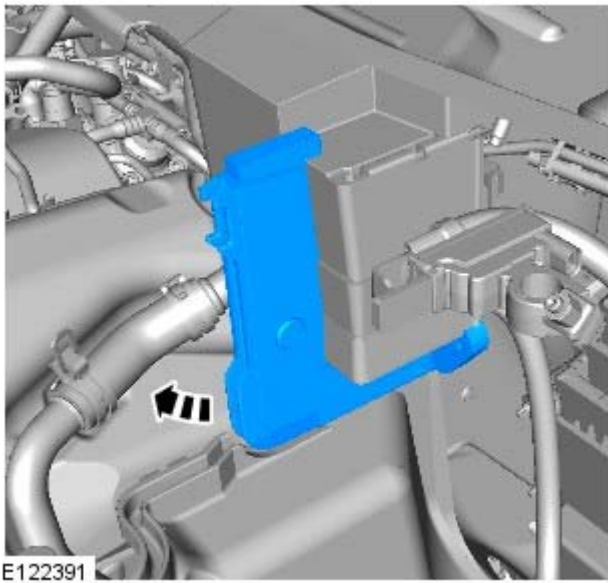

13.

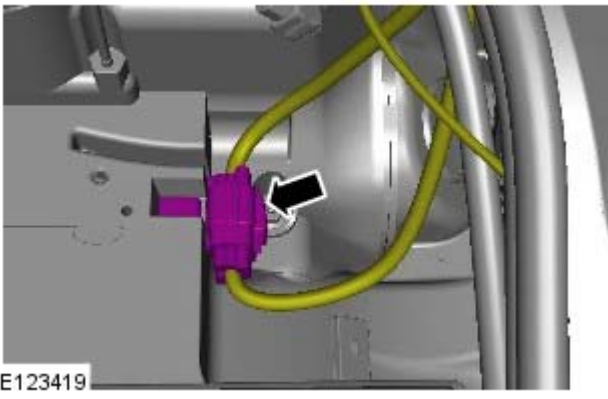

14. Torque: 9 Nm

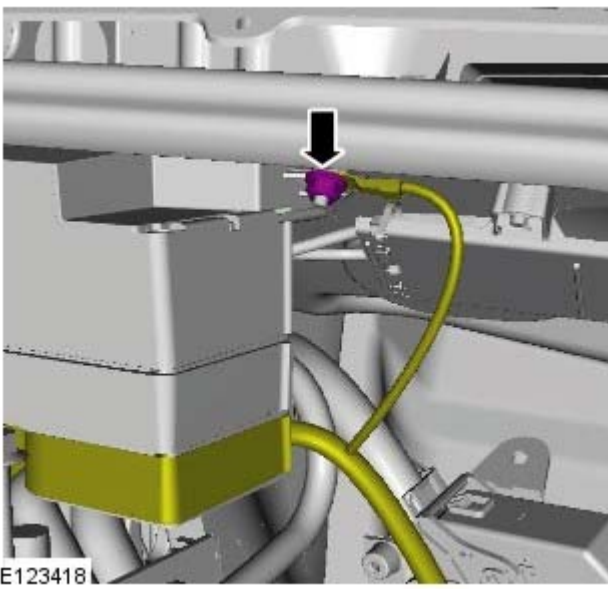

15. **15.** NOTE: RHD illustration shown, LHD is similar.

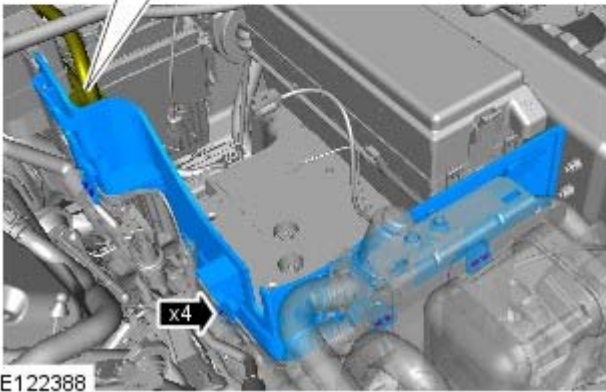
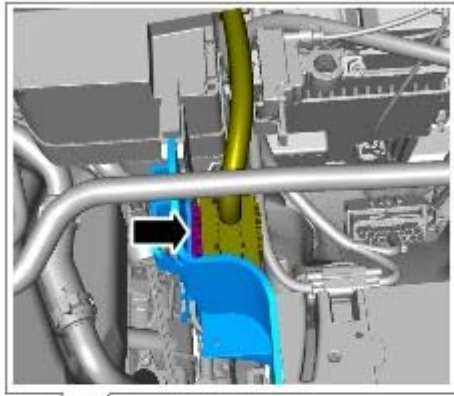

E122388

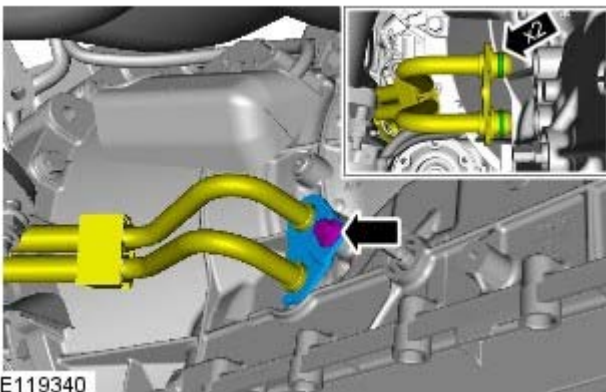

E119340

16. **16.**  **WARNING:** Be prepared to collect escaping fluids.
- Install new O-ring seals.
 - *Torque:* 12 Nm

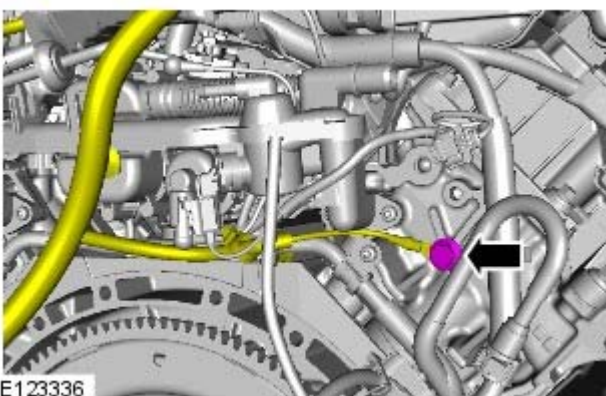

E123336

17.

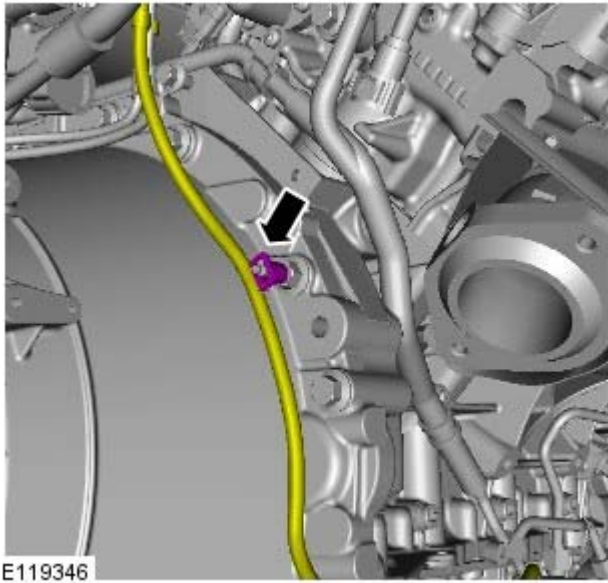

18.

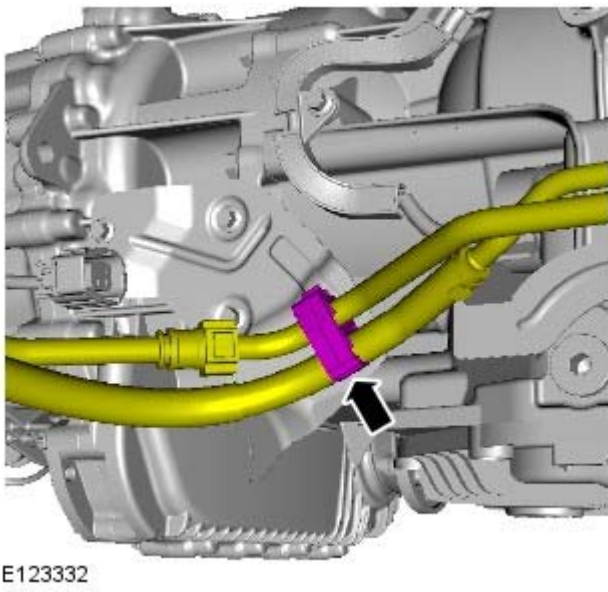

19.

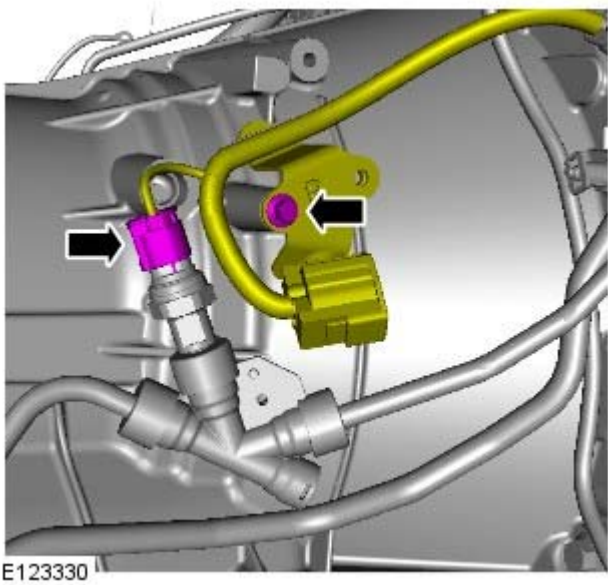

20. Torque: 10 Nm

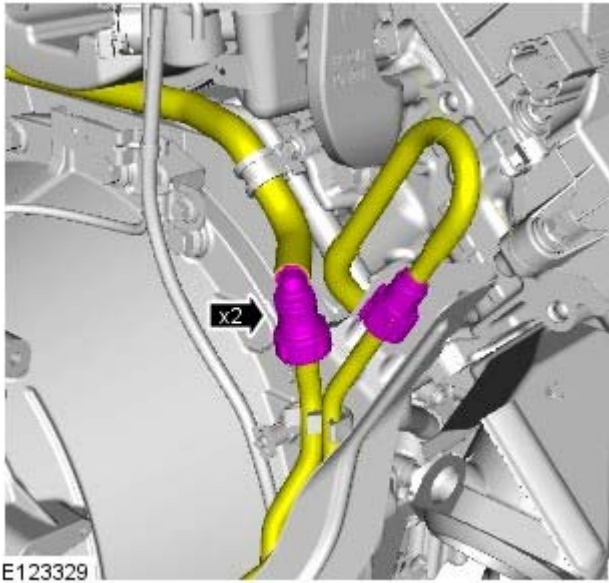

21. **21.**  **WARNING:** Do not smoke or carry lighted tobacco or open flame of any type when working on or near any fuel related components. Highly flammable vapors are always present and may ignite. Failure to follow these instructions may result in personal injury.

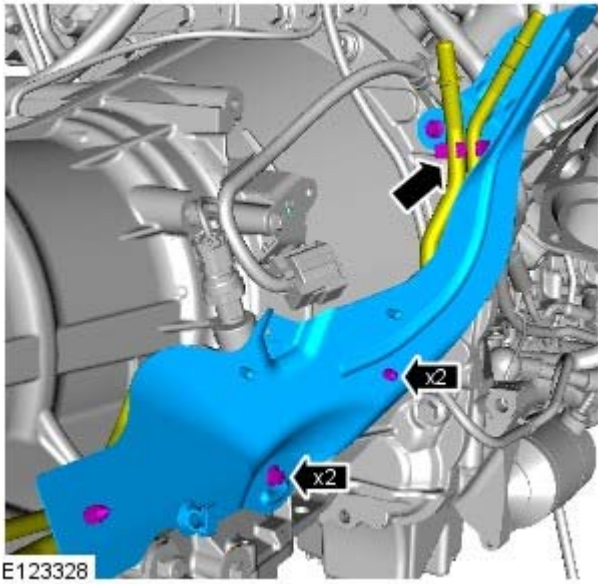

22. *Torque:* 10 Nm



23. *Torque:* 10 Nm

24. Torque: 9 Nm

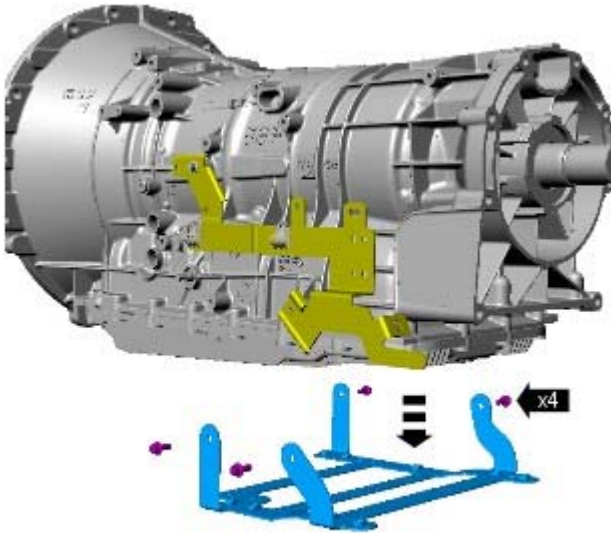

E123334

25. Torque:
M6 Bolt 10 Nm
M6 Nut 12 Nm

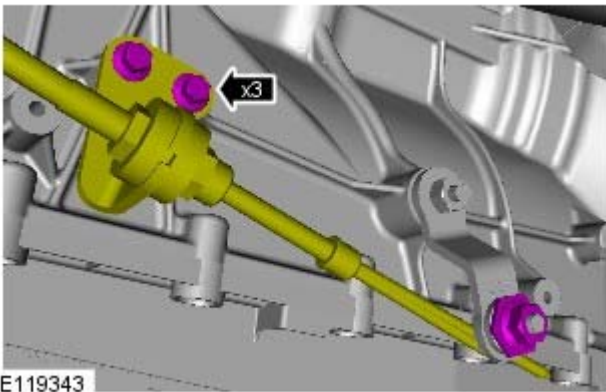

E119343

26. Torque: 8 Nm

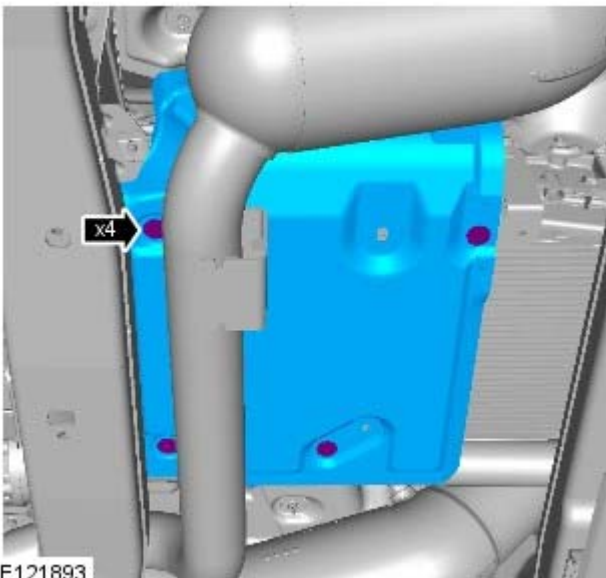

E121893

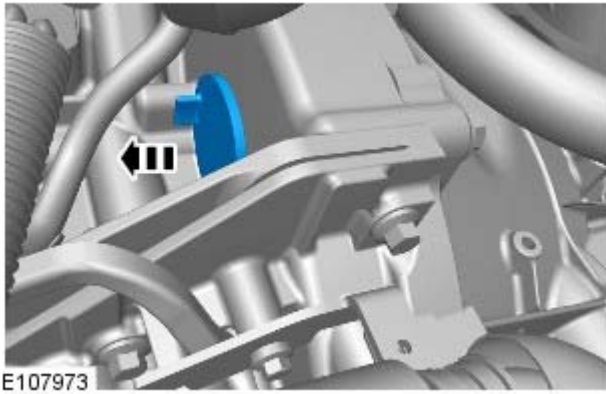

27.

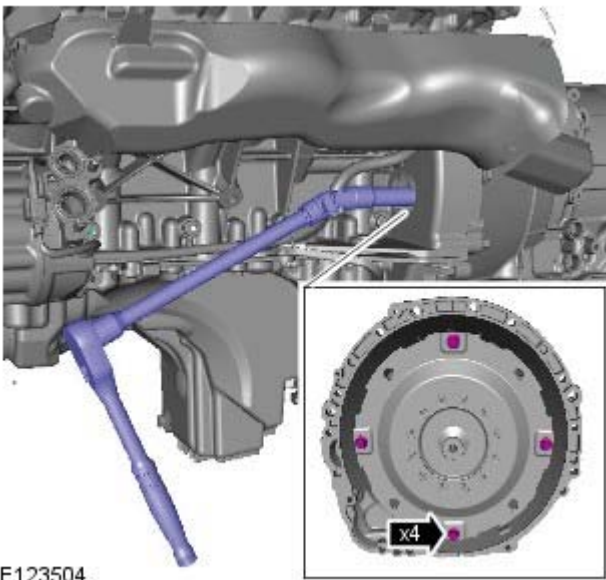

28. **28.**  **CAUTION:** Only rotate the crankshaft clockwise.

Make sure that the alignment mark is visible through the inspection hole on install of the first torque converter bolt.

Torque: 63 Nm

29. Refer to: [Front Driveshaft - V8 5.0L Petrol](#) (205-01 Driveshaft, Removal and Installation).

30. Refer to: [Exhaust System](#) (309-00D Exhaust System - V8 5.0L Petrol, Removal and Installation).

31. Refer to: [Rear Driveshaft](#) (205-01 Driveshaft, Removal and Installation).

32. Refer to: [Axle Assembly](#) (205-03 Front Drive Axle/Differential, Removal and Installation).

33. **33.**  **WARNING:** Make sure to support the vehicle with axle stands.

Lower the vehicle.

34. Install the battery.

Refer to: [Battery](#) (414-01 Battery, Mounting and Cables, Removal and Installation).

Automatic Transmission/Transaxle - V8 5.0L Petrol/TDV6 3.0L Diesel - TransmissionTDV6 3.0L Diesel

Installation

Special Tool(s)

 <p>303-1069 Adaptor, Wrench</p> <p>E53727</p>	<p>303-1069 Adaptor, Wrench</p>
---	-------------------------------------

- NOTE: Some variation in the illustrations may occur, but the essential information is always correct.
- NOTE: Some illustrations may show the transmission removed for clarity.
- NOTE: Some illustrations may show the engine removed for clarity.

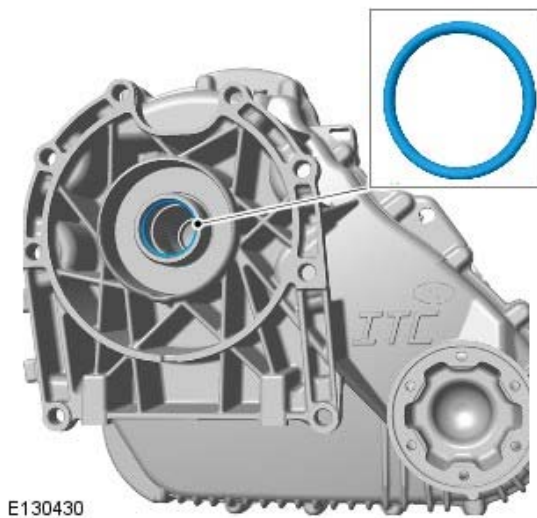

1. **NOTE:** This step is only required if previously removed.
 - NOTE: Install a new O-ring seal.

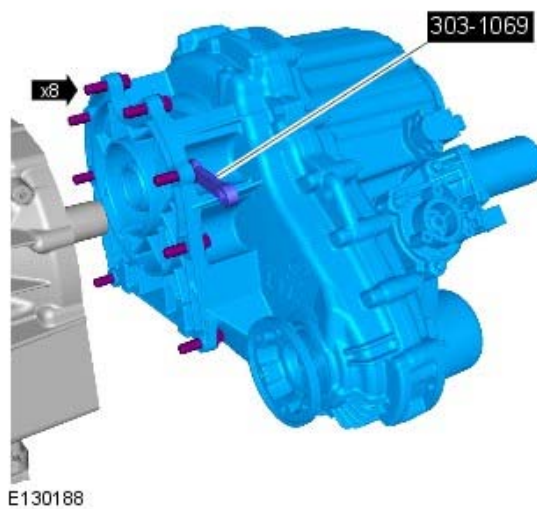

2. **NOTE:** This step is only required if previously removed.
 - Clean the component mating faces.
 - Lubricate input shaft splines with 'Weicon TL7391' grease.
 - *Special Tool(s):* [303-1069](#)
 - *Torque:* 45 Nm

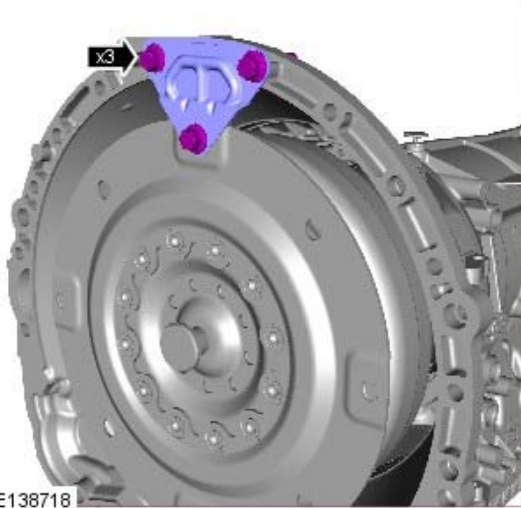

3.  CAUTION: Make sure that the torque converter remains in the transmission.

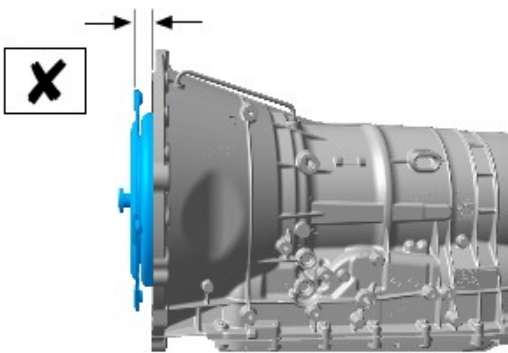

4.  CAUTION: Make sure the torque converter is fully located into the oil pump drive.

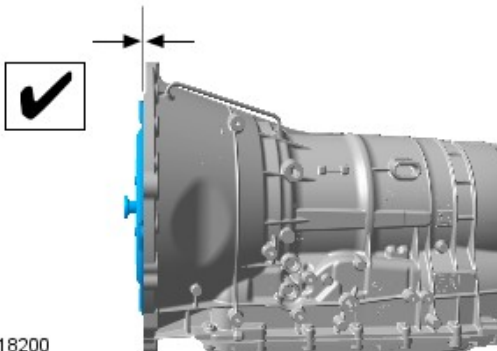

E118200

5. **5. CAUTIONS:**

 Apply grease of the correct specification to the torque converter spigot.

 Make sure that the torque converter remains in the transmission.

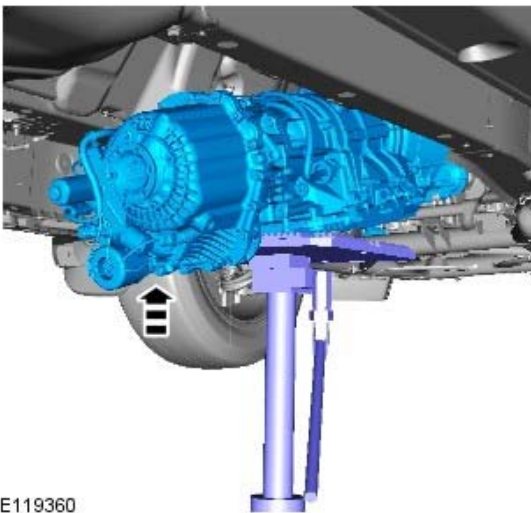

E119360

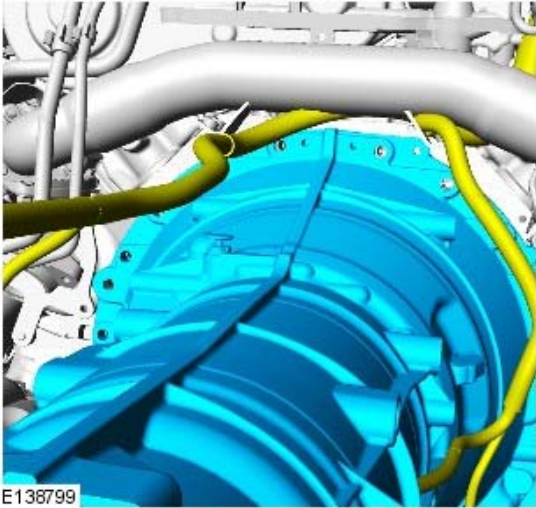

E138799

6.  CAUTION: Care must be taken to avoid damaging the transmission wiring harness.

Cut the cable ties securing the harness.

7. Torque: 40 Nm

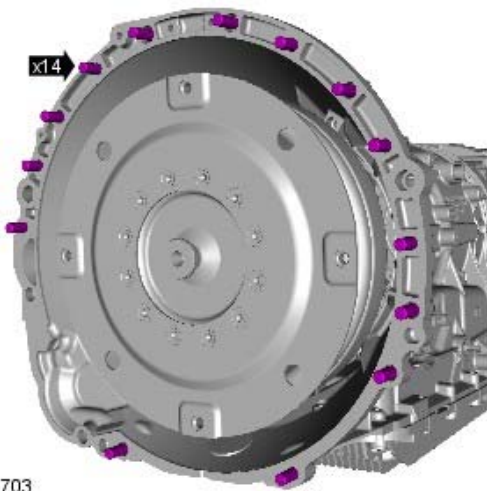

E138703

8. Torque: 63 Nm

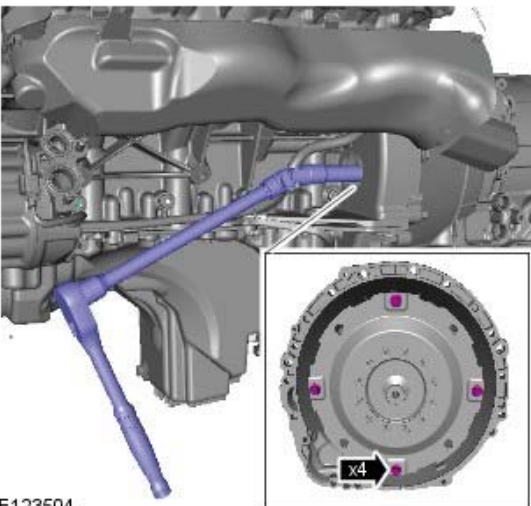

E123504

9.

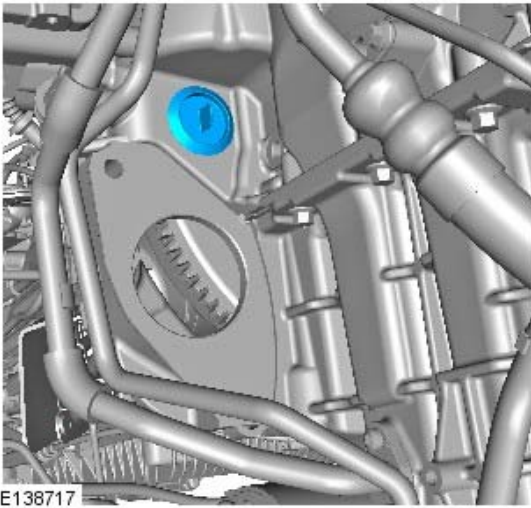

10. Refer to: Starter Motor (303-06, Removal and Installation).

11.

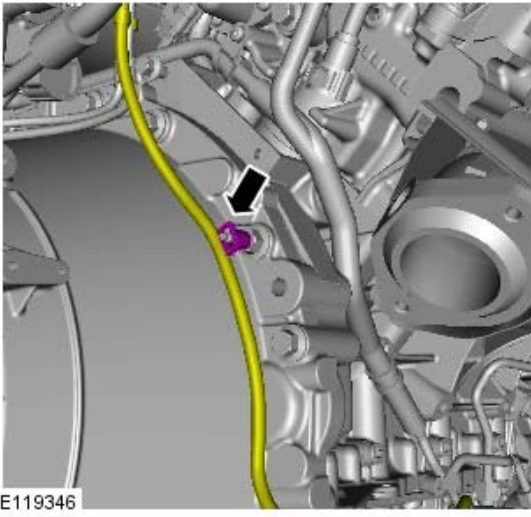

12. Torque: 23 Nm

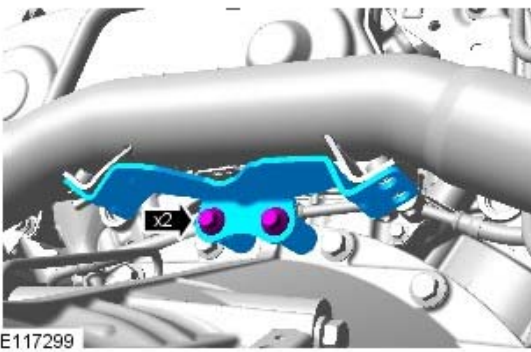

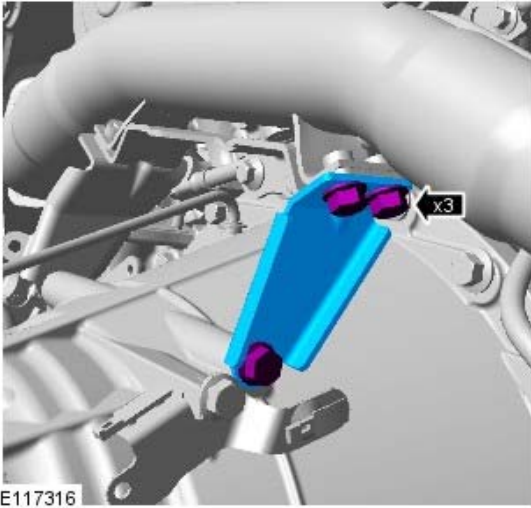

13. **13.** ⚠ CAUTION: Only tighten the bolts finger-tight at this stage.

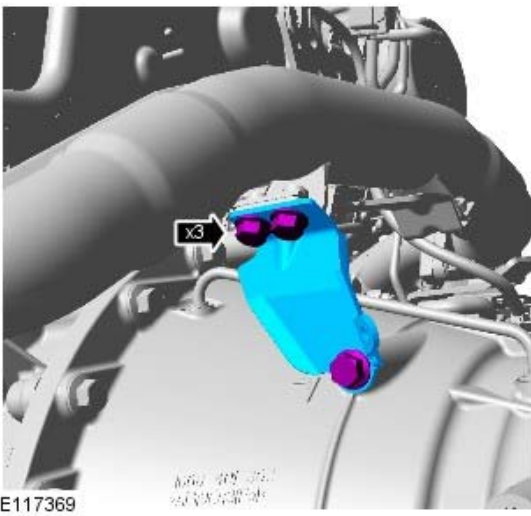

14. **14.** ⚠ CAUTION: Only tighten the bolts finger-tight at this stage.

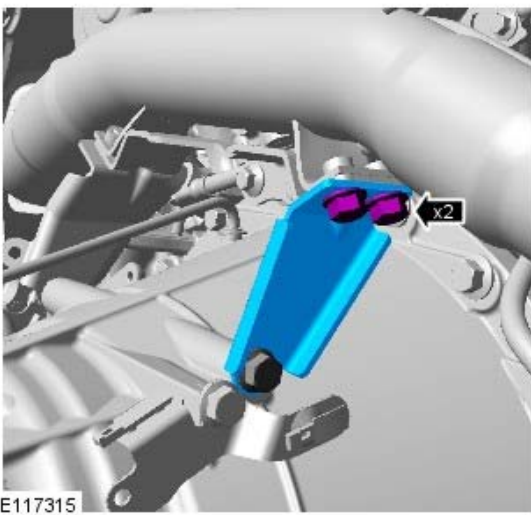

15. Torque: 23 Nm

16. Torque: 23 Nm

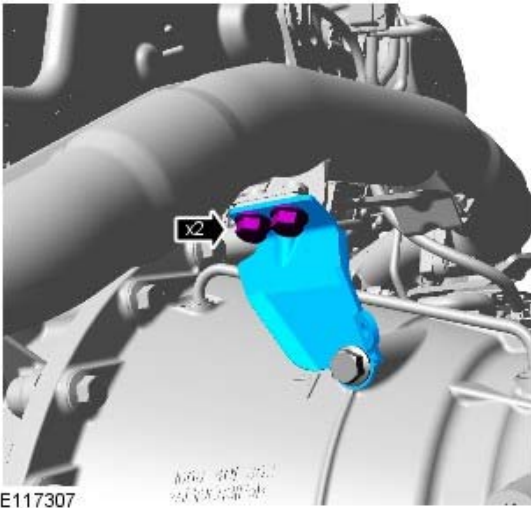

17. Torque: 23 Nm

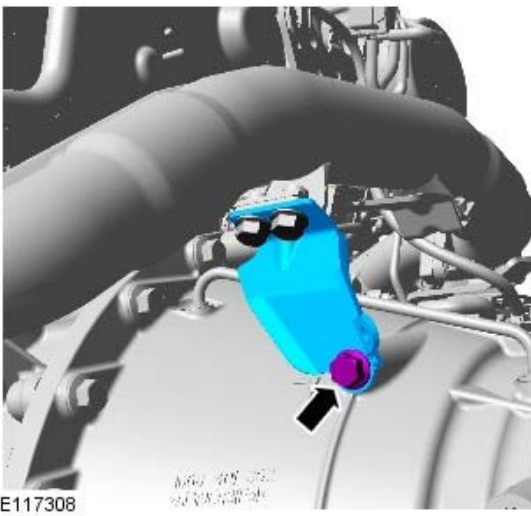

18. Torque: 23 Nm

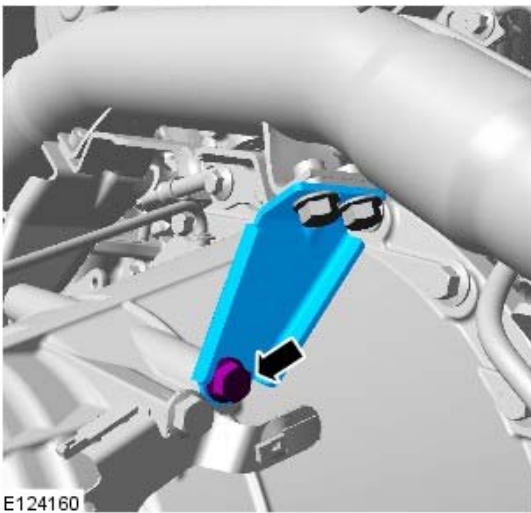

19.

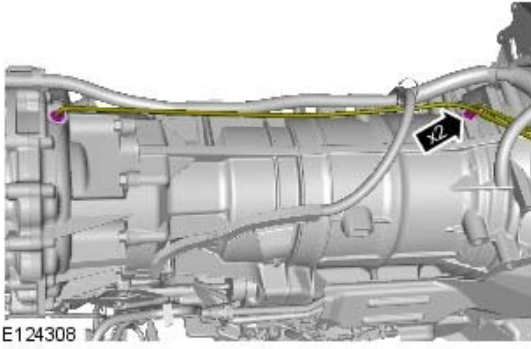

20. **⚠️ WARNING:** Do not smoke or carry lighted tobacco or open flame of any type when working on or near any fuel related components. Highly flammable vapors are always present and may ignite. Failure to follow these instructions may result in personal injury.

⚠️ CAUTION: Be prepared to collect escaping fluids.

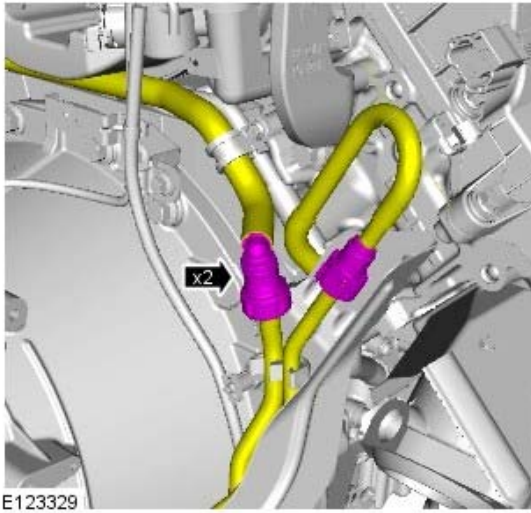

21. *Torque:*
M6 9 Nm
M10 40 Nm

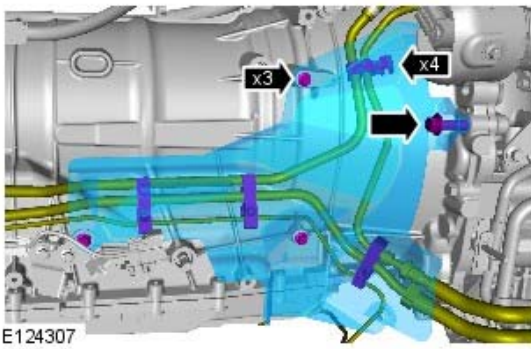

22. *Torque:* 9 Nm

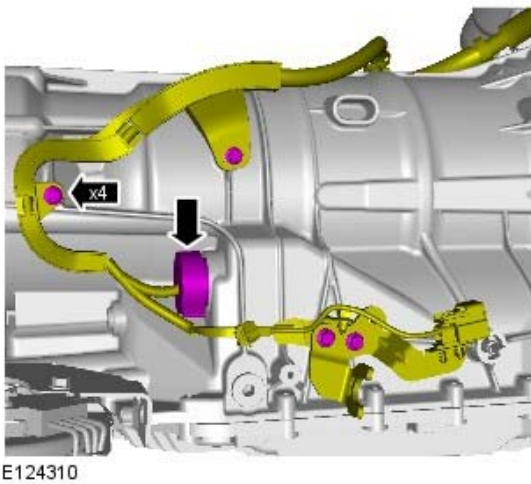

23. Torque: 9 Nm

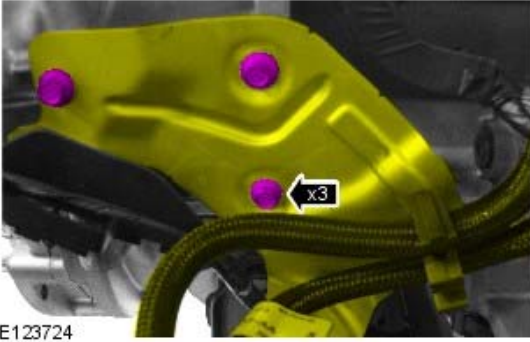

24. Torque: 9 Nm

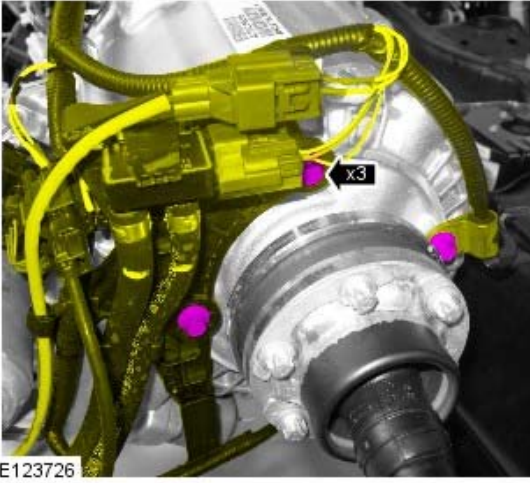

25.

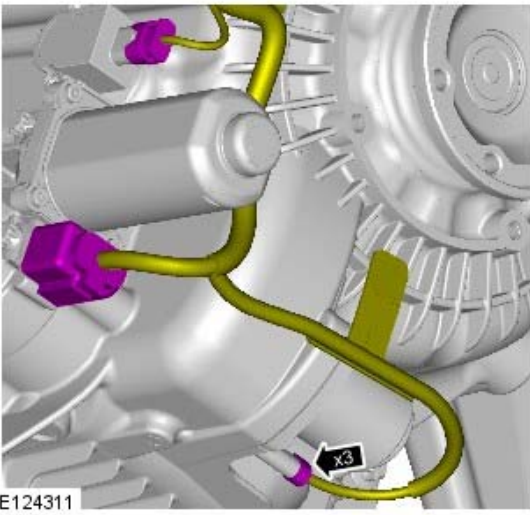

26. Torque: 9 Nm

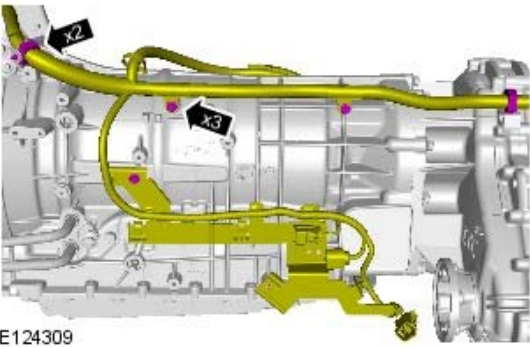

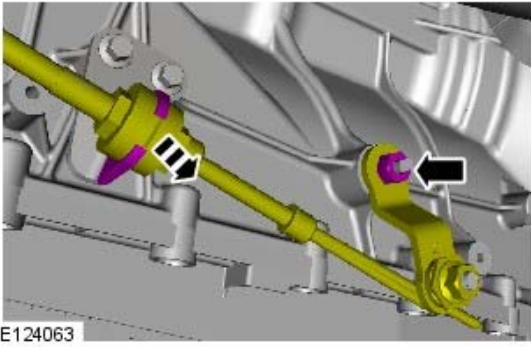

27. Torque: 12 Nm

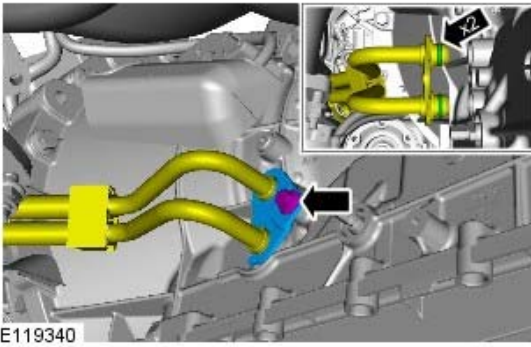

28. **28.** NOTE: Install new O-ring seals.

Torque: 12 Nm

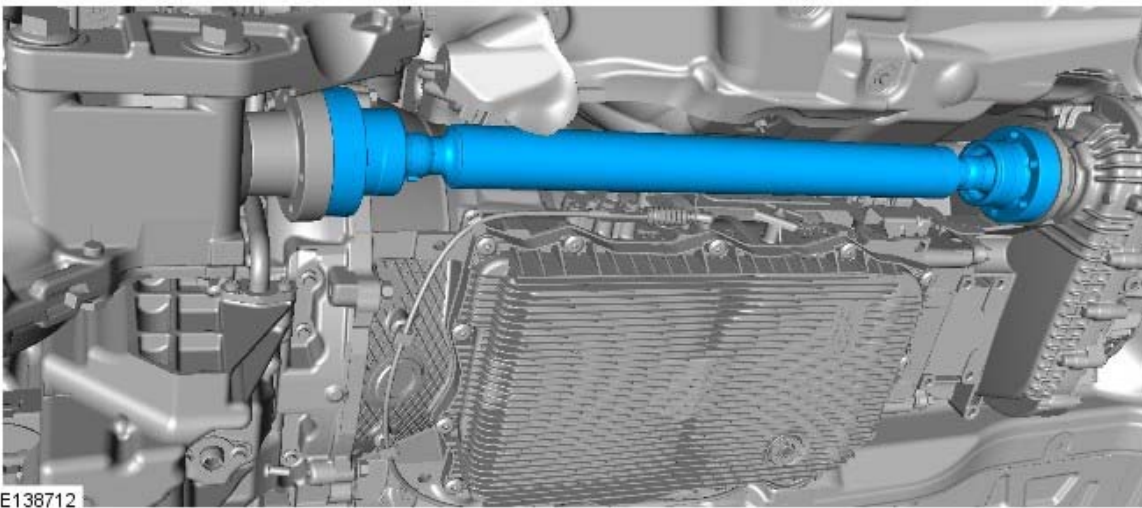

29. Using a suitable tie strap, secure the driveshaft.

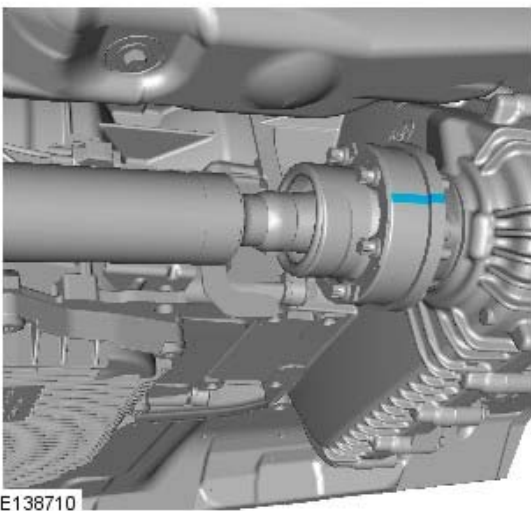

30. **30.** NOTE: Make sure that the component aligns with the installation mark noted in the removal step.

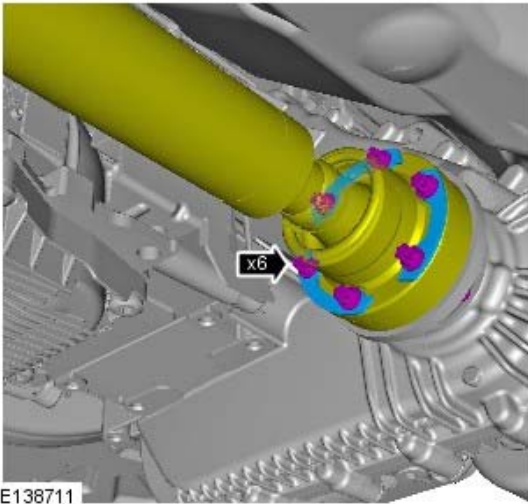

31. **31.**  CAUTION: Make sure that new bolts are installed.

Torque:

Stage 1: 45 Nm
Stage 2: 90°

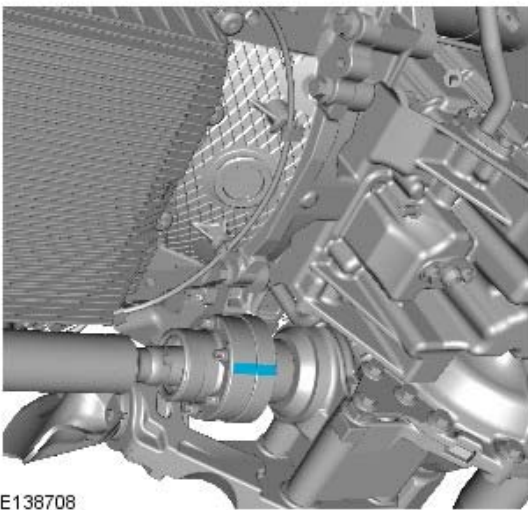

32. **32.** NOTE: Make sure that the component aligns with the installation mark noted in the removal step.

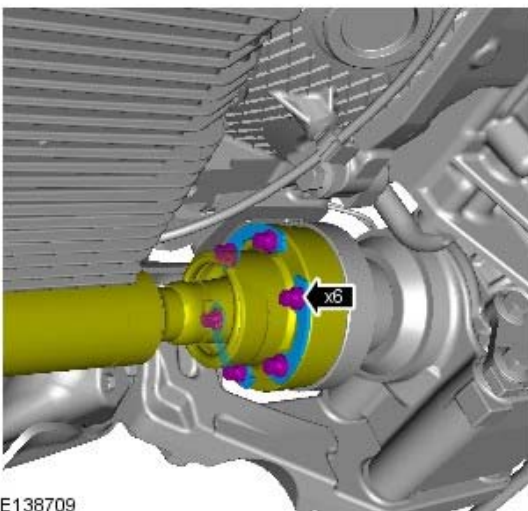

33. **33.**  CAUTION: Make sure that new bolts are installed.

Torque:

Stage 1: 45 Nm
Stage 2: 90°

34. Refer to: [Catalytic Converter](#) (309-00B Exhaust System - TDV6 3.0L Diesel, Removal and Installation).

35.

- Remove the securing straps.
- Remove the jack supporting the transmission.

36. Refer to: [Rear Driveshaft](#) (205-01 Driveshaft, Removal and Installation).

37.

- Connect the battery ground cable.
- Refer to: Specifications (414-00, Specifications).

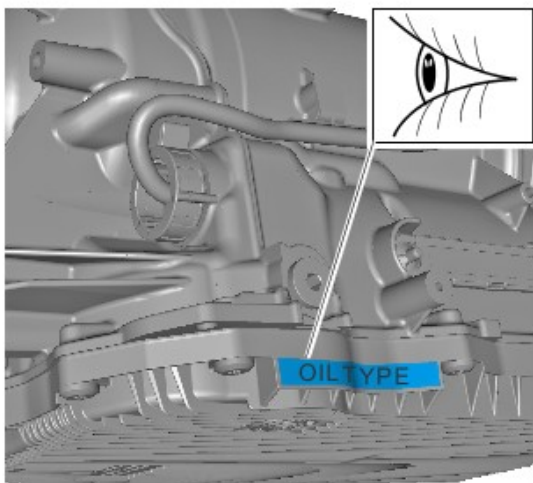

E138154

38. **38. CAUTIONS:**



Make sure the correct specification of oil is used.



Make sure the transmission fluid fill plug is tightened to the correct specification. Failure to follow this instruction may result in damage to the vehicle.

• **NOTE:** Install a new fluid level filler plug.

- Carry out a transmission fluid level check.
- To make sure the transmission fill plug is torqued to the correct specification. Using the special tool and torque wrench the following calculation steps must be followed.
- Step 1. Multiply 35 Nm by the effective length of the torque wrench (1).
- Step 2. Add the effective length of the special tool (2) to the effective length of the torque wrench (1).
- Step 3. Divide the total of step 1 by the total of step 2.
- Step 4. Set the torque wrench to the figure arrived at in step 3.
- Tighten the transmission fluid fill plug to the torque given by the calculation.

Transmission/Transaxle Cooling - TDV6 2.7L Diesel - Transmission Cooling

Diagnosis and Testing

Principle of Operation

For a detailed description of the automatic transmission cooling system, refer to the relevant Description and Operation sections in the workshop manual.

Inspection and Verification

1. **1.** Verify the customer concern by operating the system.
2. **2.** Visually inspect for obvious signs of damage and system integrity.

Visual Inspection

Mechanical
<ul style="list-style-type: none"> ● Feed and return tubes ● Connections to the automatic transmission and the automatic transmission fluid cooler ● Automatic transmission fluid level

3. **3.** If an obvious cause for an observed or reported concern is found, correct the cause (if possible) before proceeding to the next step.
4. **4.** If the cause is not visually evident, verify the symptom and refer to the Symptom Chart, alternatively check for Diagnostic Trouble Codes (DTCs) and refer to the DTC Index.

Symptom Chart

Condition	Possible Causes	Action
Over heating of the automatic transmission	Obstruction in the automatic transmission fluid cooler	Flush out the automatic transmission fluid cooler with new automatic transmission fluid. If the flushing is unsuccessful, install a new transmission fluid cooler. REFER to: Transmission Fluid Cooler (307-02A Transmission/Transaxle Cooling - TDV6 2.7L Diesel, Removal and Installation).
Over heating of the automatic transmission	Obstruction in the automatic transmission fluid tubes	Flush out the automatic transmission fluid cooler tubes with new automatic transmission fluid. If the flushing is unsuccessful install new automatic transmission fluid cooler tubes.
Loss of automatic transmission fluid	Connections to the automatic transmission and the automatic transmission fluid cooler	Check the integrity of the tubes, connections and seals. Check the torque of the tube fixings.
Loss of automatic transmission fluid	Leak at oil cooler	Check the integrity of tubes, connections and seals. Check the torque of the tube fixings.

DTC Index

For a list of Diagnostic Trouble Codes (DTCs) that could be logged on this vehicle, please refer to Section 100-00. REFER to: [Diagnostic Trouble Code \(DTC\) Index - DTC: Transmission Control Module \(TCM\) - Bosch](#) (100-00 General Information, Description and Operation).

Transmission/Transaxle Cooling - TDV6 2.7L Diesel - Transmission Fluid Cooler

Removal and Installation

Removal

- NOTE: The transmission fluid cooler is part of the radiator assembly and cannot be serviced separately.

1. Remove the radiator.

For additional information, refer to: [Radiator](#) (303-03A Engine Cooling - TDV6 2.7L Diesel, Removal and Installation).

Installation

1. Install the radiator.

For additional information, refer to: [Radiator](#) (303-03A Engine Cooling - TDV6 2.7L Diesel, Removal and Installation).

Transmission/Transaxle Cooling - TDV6 2.7L Diesel - Transmission Fluid Cooler Tubes

Removal and Installation

Removal

1. Disconnect the battery ground cable.
For additional information, refer to: [Specifications](#) (414-00 Battery and Charging System - General Information, Specifications).
2. Remove the coolant expansion tank.
For additional information, refer to: [Coolant Expansion Tank](#) (303-03A Engine Cooling - TDV6 2.7L Diesel, Removal and Installation).

3. ⚠ CAUTION: Before disconnecting or removing the components, make sure the area around the joint faces and connections are clean. Plug open connections to prevent contamination.

- NOTE: Some fluid spillage is inevitable during this operation.
- NOTE: Fan shroud shown removed for clarity.

Disconnect the 2 transmission fluid cooler coolant hoses.

- Position a container to collect the fluid spillage.
- Release the 2 clips.

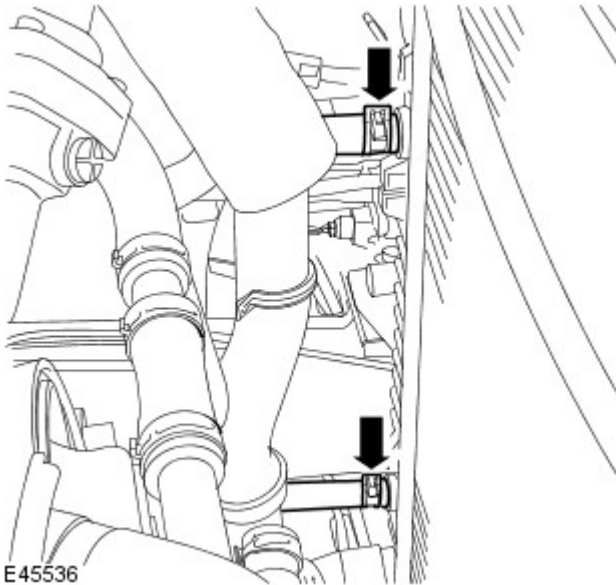

4. ⚠ WARNING: Do not work on or under a vehicle supported only by a jack. Always support the vehicle on safety stands.

Raise and support the vehicle.

5. Remove the front LH splash shield.

- Remove the 4 clips.

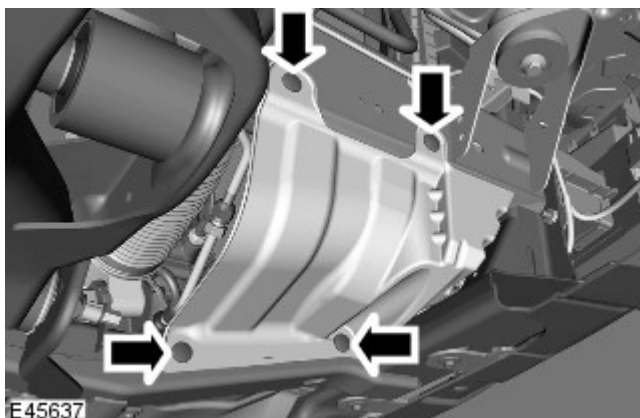

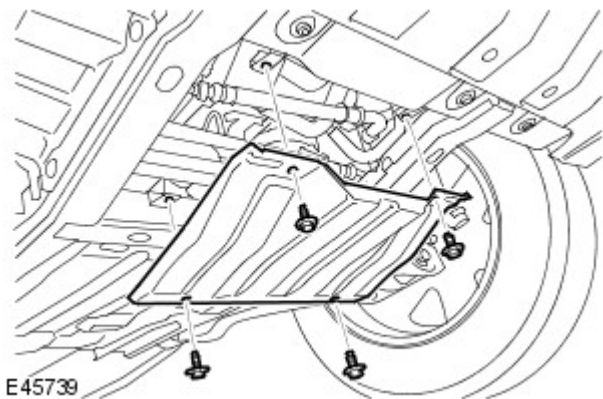

6. Remove the radiator access panel.

- Remove the 4 bolts.

7. Remove the front driveshaft.

For additional information, refer to: [Front Driveshaft - TDV6 2.7L Diesel](#) (205-01 Driveshaft, Removal and Installation).

8. Release the transmission fluid cooler hoses bracket.

- Remove the bolt.

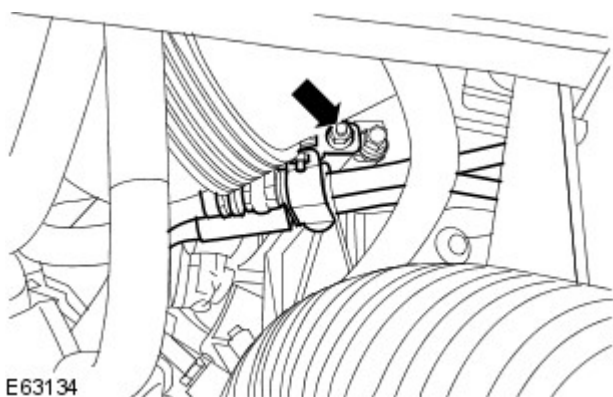

9.  **CAUTION:** Before disconnecting or removing the components, make sure the area around the joint faces and connections are clean. Plug open connections to prevent contamination.

• **NOTE:** Some fluid spillage is inevitable during this operation.

Remove the transmission fluid cooler hoses.

- Position a container to collect spillage.
- Remove the bolt.

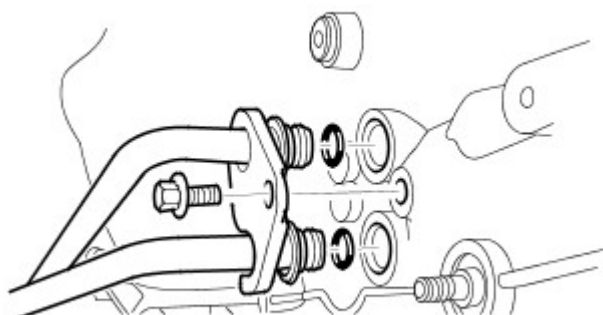

10. Remove and discard both O-ring seals.

Installation

1. To install, reverse the removal procedure.

2. Install the transmission fluid cooler hoses.

- Tighten the bolt to 10 Nm.

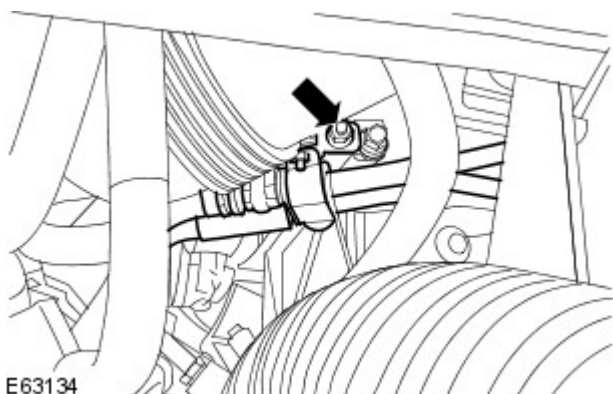

3. Connect the transmission fluid cooler hoses.

- Tighten the bolt to 10 Nm.

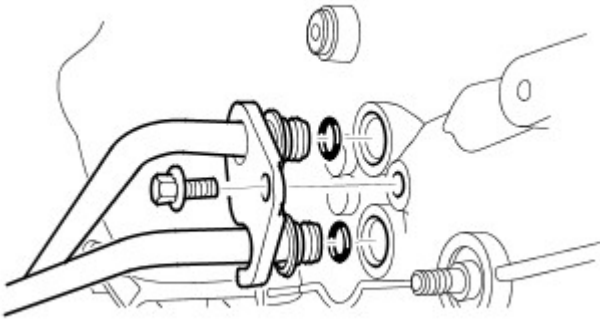

E60442

4. Check and top-up the transmission fluid level.
For additional information, refer to: [Transmission Fluid Level Check](#) (307-01B Automatic Transmission/Transaxle - V6 4.0L Petrol, General Procedures).

Transmission/Transaxle Cooling - V6 4.0L Petrol - Transmission Cooling

Diagnosis and Testing

Principle of Operation

For a detailed description of the automatic transmission cooling system, refer to the relevant Description and Operation sections in the workshop manual.

Inspection and Verification

1. **1.** Verify the customer concern by operating the system.
2. **2.** Visually inspect for obvious signs of damage and system integrity.

Visual Inspection

Mechanical
<ul style="list-style-type: none"> ● Feed and return tubes ● Connections to the automatic transmission and the automatic transmission fluid cooler ● Automatic transmission fluid level

3. **3.** If an obvious cause for an observed or reported concern is found, correct the cause (if possible) before proceeding to the next step.
4. **4.** If the cause is not visually evident, verify the symptom and refer to the Symptom Chart, alternatively check for Diagnostic Trouble Codes (DTCs) and refer to the DTC Index.

Symptom Chart

Condition	Possible Causes	Action
Over heating of the automatic transmission	Obstruction in the automatic transmission fluid cooler	Flush out the automatic transmission fluid cooler with new automatic transmission fluid. If the flushing is unsuccessful, install a new transmission fluid cooler. REFER to: Transmission Fluid Cooler (307-02A Transmission/Transaxle Cooling - TDV6 2.7L Diesel, Removal and Installation).
Over heating of the automatic transmission	Obstruction in the automatic transmission fluid tubes	Flush out the automatic transmission fluid cooler tubes with new automatic transmission fluid. If the flushing is unsuccessful install new automatic transmission fluid cooler tubes.
Loss of automatic transmission fluid	Connections to the automatic transmission and the automatic transmission fluid cooler	Check the integrity of the tubes, connections and seals. Check the torque of the tube fixings.
Loss of automatic transmission fluid	Leak at oil cooler	Check the integrity of tubes, connections and seals. Check the torque of the tube fixings.

DTC Index

For a list of Diagnostic Trouble Codes (DTCs) that could be logged on this vehicle, please refer to Section 100-00. REFER to: [Diagnostic Trouble Code \(DTC\) Index - DTC: Transmission Control Module \(TCM\) - Bosch](#) (100-00 General Information, Description and Operation).

Transmission/Transaxle Cooling - V6 4.0L Petrol - Transmission Fluid Cooler

Removal and Installation

Removal

- NOTE: The transmission fluid cooler is part of the radiator assembly and cannot be serviced separately.

1. Remove the radiator.

For additional information, refer to: [Radiator](#) (303-03C Engine Cooling - V6 4.0L Petrol, Removal and Installation).

Installation

1. Install the radiator.

For additional information, refer to: [Radiator](#) (303-03C Engine Cooling - V6 4.0L Petrol, Removal and Installation).

Transmission/Transaxle Cooling - V8 5.0L Petrol/TDV6 3.0L Diesel -

Lubricants

- CAUTIONS:



Do not use any lubricant other than that specified.



Do not over lubricate.

Item	Specification
Transmission fluid	ATF Shell M 1375.4 Land Rover Part No. TYK500050

Capacity

Item	Capacity
Initial dry fill	9.5 Litres (16.7 pints) (10.0 US quarts)

Torque Specification

Description	Nm	lb-ft	lb-in
Transmission fluid cooler tube to transmission housing bolt	23	17	-
Transmission fluid cooler tube bracket retaining bolt - vehicles with Engine 5.0L	10	7	-
Transmission fluid cooler tube bracket retaining nut - vehicles with Engine 3.0D	11	8	-
Transmission fluid cooler retaining bolts	25	18	-
Transmission fluid cooler tube line union to cooler	16	12	-

Transmission/Transaxle Cooling - V8 5.0L Petrol/TDV6 3.0L Diesel - Transmission Cooling

Description and Operation

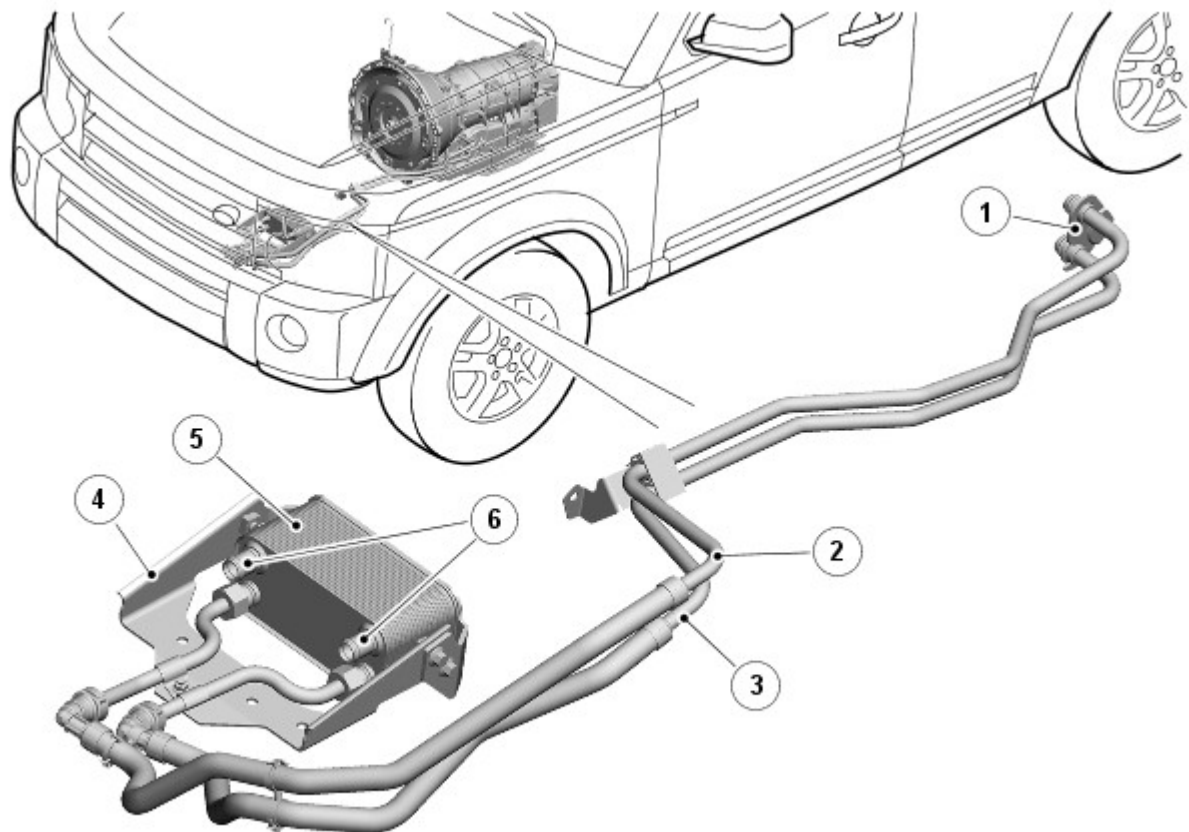

E122434

Item	Part Number	Description
1	-	Latch-plate
2	-	Return hose and pipe (to transmission)
3	-	Feed hose and pipe (from transmission)
4	-	Mounting bracket
5	-	Transmission fluid cooler
6	-	Engine coolant hose connections

INTRODUCTION

Transmission cooling is provided by a transmission fluid cooler, which transfers heat from the transmission to the engine cooling system. The transmission fluid cooler is installed in the engine compartment, on a mounting bracket attached to the crossmember of the secondary loadpath frame.

Two hose and pipe assemblies connect the transmission fluid cooler to the automatic transmission. Two engine coolant hose connections are incorporated into the transmission fluid cooler for the supply and return of coolant from the engine cooling system.

For additional information, refer to: [Engine Cooling](#) (303-03D Engine Cooling - V8 5.0L Petrol, Description and Operation).

Fluid from the pump in the automatic transmission flows through the feed hose and pipe to the transmission fluid cooler. The fluid then flows through the transmission fluid cooler, and the return hose and pipe, to the sump of the automatic transmission.

Transmission/Transaxle Cooling - V8 5.0L Petrol/TDV6 3.0L Diesel - Transmission Cooling

Diagnosis and Testing

Principle of Operation

For a detailed description of the automatic transmission cooling system, refer to the relevant Description and Operation sections in the workshop manual.

Inspection and Verification

1. **1.** Verify the customer concern by operating the system.
2. **2.** Visually inspect for obvious signs of damage and system integrity.

Visual Inspection

Mechanical
<ul style="list-style-type: none"> ● Feed and return tubes ● Connections to the automatic transmission and the automatic transmission fluid cooler ● Automatic transmission fluid level

3. **3.** If an obvious cause for an observed or reported concern is found, correct the cause (if possible) before proceeding to the next step.
4. **4.** If the cause is not visually evident, verify the symptom and refer to the Symptom Chart, alternatively check for Diagnostic Trouble Codes (DTCs) and refer to the DTC Index.

Symptom Chart

Condition	Possible Causes	Action
Over heating of the automatic transmission	Obstruction in the automatic transmission fluid cooler	Flush out the automatic transmission fluid cooler with new automatic transmission fluid. If the flushing is unsuccessful, install a new transmission fluid cooler. REFER to: Transmission Fluid Cooler (307-02A Transmission/Transaxle Cooling - TDV6 2.7L Diesel, Removal and Installation).
Over heating of the automatic transmission	Obstruction in the automatic transmission fluid tubes	Flush out the automatic transmission fluid cooler tubes with new automatic transmission fluid. If the flushing is unsuccessful install new automatic transmission fluid cooler tubes.
Loss of automatic transmission fluid	Connections to the automatic transmission and the automatic transmission fluid cooler	Check the integrity of the tubes, connections and seals. Check the torque of the tube fixings.
Loss of automatic transmission fluid	Leak at oil cooler	Check the integrity of tubes, connections and seals. Check the torque of the tube fixings.

DTC Index

For a list of Diagnostic Trouble Codes (DTCs) that could be logged on this vehicle, please refer to Section 100-00. REFER to: [Diagnostic Trouble Code \(DTC\) Index - DTC: Transmission Control Module \(TCM\) - Siemens](#) (100-00 General Information, Description and Operation).

Transmission/Transaxle Cooling - V8 5.0L Petrol/TDV6 3.0L Diesel - Transmission Fluid Cooler V8 5.0L Petrol

Removal and Installation

Removal

- NOTE: Removal steps in this procedure may contain installation details.

1.  **WARNING:** Make sure to support the vehicle with axle stands.
Raise and support the vehicle.
2. Refer to: [Cooling System Draining, Filling and Bleeding](#) (303-03D Engine Cooling - V8 5.0L Petrol, General Procedures).
3. Refer to: [Transmission Fluid Level Check](#) (307-01D Automatic Transmission/Transaxle - V8 5.0L Petrol/TDV6 3.0L Diesel, General Procedures).

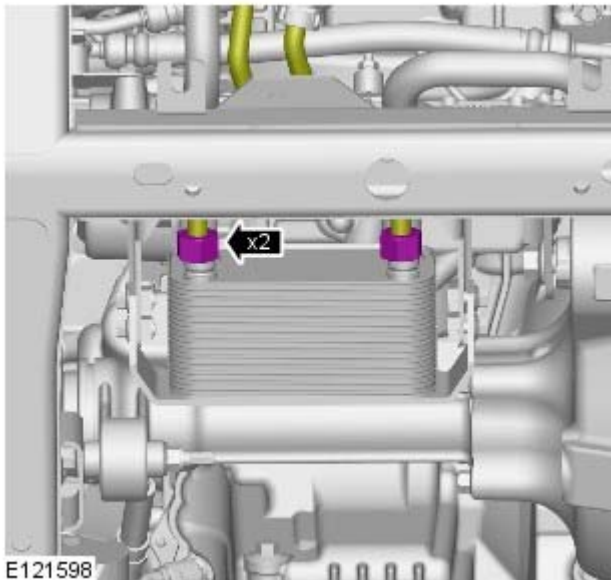

4.  **WARNING:** Be prepared to collect escaping fluids.

 **CAUTION:** Before disconnecting or removing the components, make sure the area around the joint faces and connections are clean and dry. Plug open connections to prevent contamination.

Torque: 16 Nm

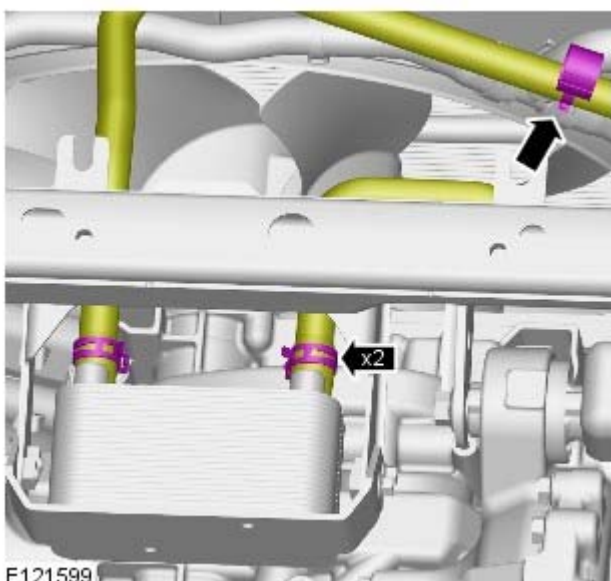

5.  **WARNING:** Be prepared to collect escaping fluids.

6. Torque: 25 Nm

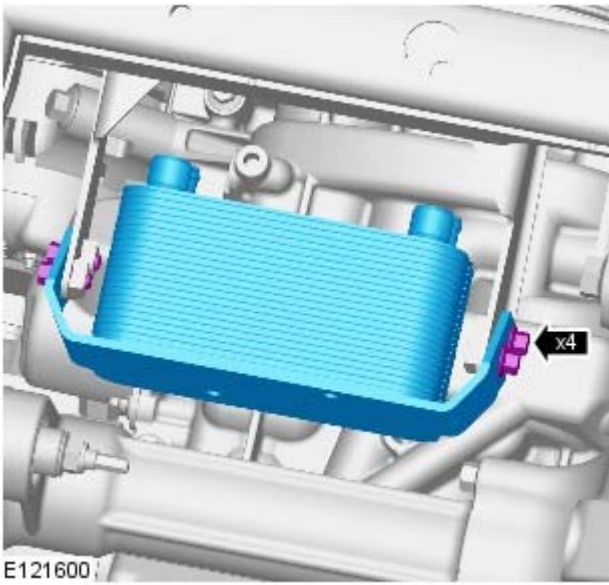

Installation

1. To install, reverse the removal procedure.

Transmission/Transaxle Cooling - V8 5.0L Petrol/TDV6 3.0L Diesel - Transmission Fluid CoolerTDV6 3.0L Diesel

Removal and Installation

Removal

- NOTE: Removal steps in this procedure may contain installation details.

1.  **WARNING:** Make sure to support the vehicle with axle stands.
Raise and support the vehicle.
2. Refer to: [Cooling System Draining, Filling and Bleeding](#) (303-03B Engine Cooling - TDV6 3.0L Diesel, General Procedures).
3. Refer to: [Transmission Fluid Level Check](#) (307-01D Automatic Transmission/Transaxle - V8 5.0L Petrol/TDV6 3.0L Diesel, General Procedures).

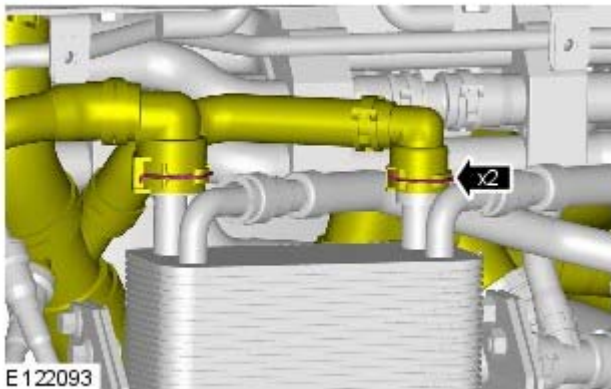

4.  **WARNING:** Be prepared to collect escaping fluids.

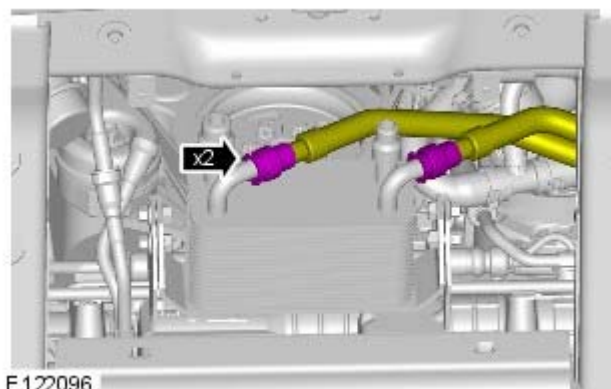

5.  **WARNING:** Be prepared to collect escaping fluids.

 **CAUTION:** Before disconnecting or removing the components, ensure the area around the joint faces and connections are clean and dry. Plug open connections to prevent contamination.

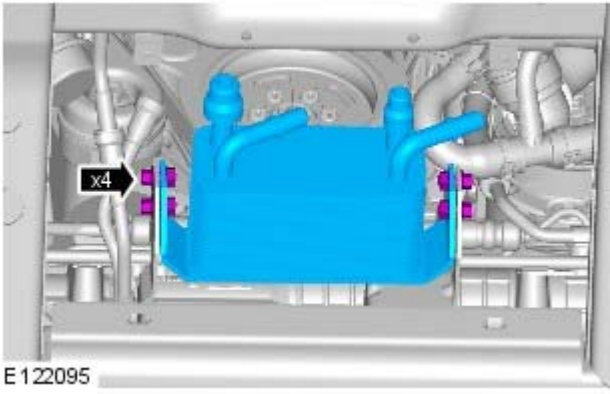

6. Torque: 23 Nm

Installation

1. To install, reverse the removal procedure.

Transmission/Transaxle Cooling - V8 5.0L Petrol/TDV6 3.0L Diesel - Transmission Fluid Cooler Tubes V8 5.0L Petrol

Removal and Installation

Removal

- NOTE: Removal steps in this procedure may contain installation details.

1.  **WARNING:** Make sure to support the vehicle with axle stands.

Raise and support the vehicle.

2. Refer to: [Engine Undershield](#) (501-02 Front End Body Panels, Removal and Installation).

3. Remove the LH front road wheel.

Torque: 140 Nm

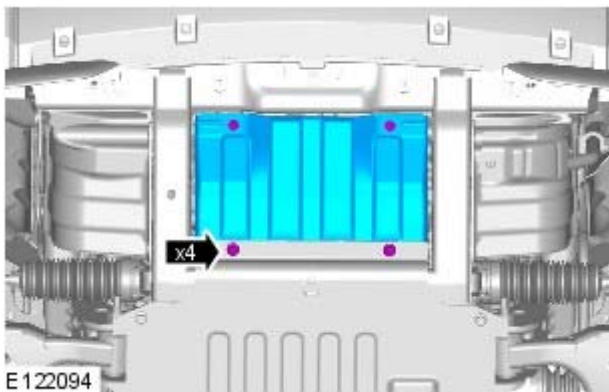

4. *Torque: 10 Nm*

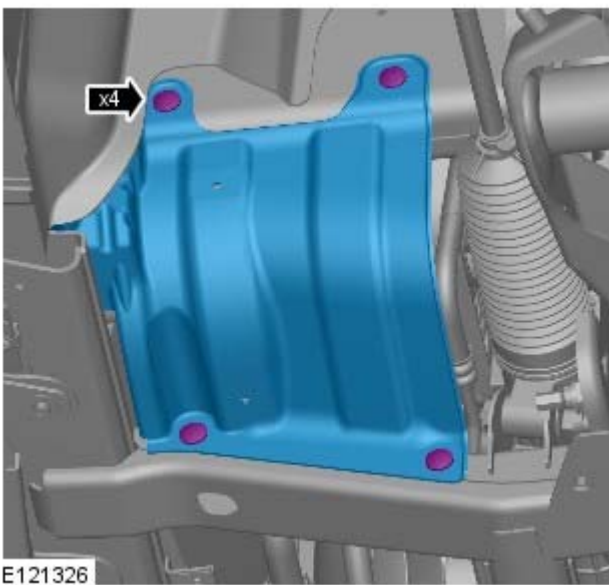

- 5.

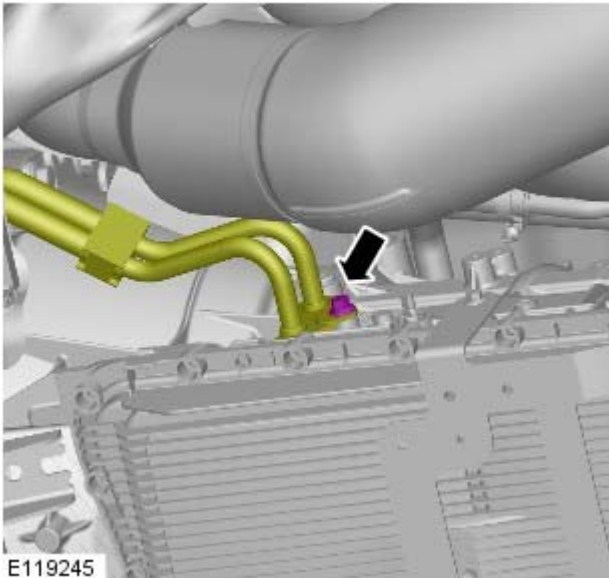

6. **⚠** WARNING: Be prepared to collect escaping fluids.

⚠ CAUTION: Always plug any open connections to prevent contamination.

- NOTE: Some variation in the illustrations may occur, but the essential information is always correct.

Torque: 23 Nm

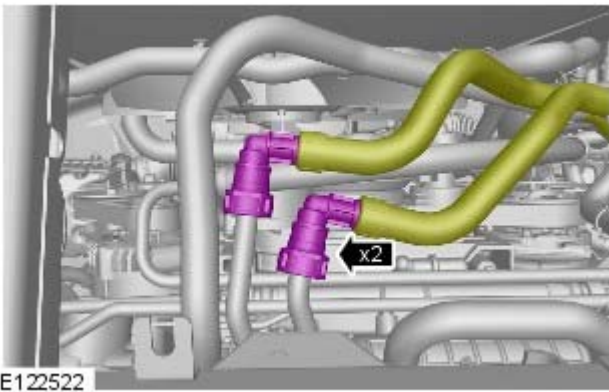

7. **⚠** WARNING: Be prepared to collect escaping fluids.

⚠ CAUTION: Before disconnecting or removing the components, make sure the area around the joint faces and connections are clean and dry. Plug open connections to prevent contamination.

Torque: 16 Nm

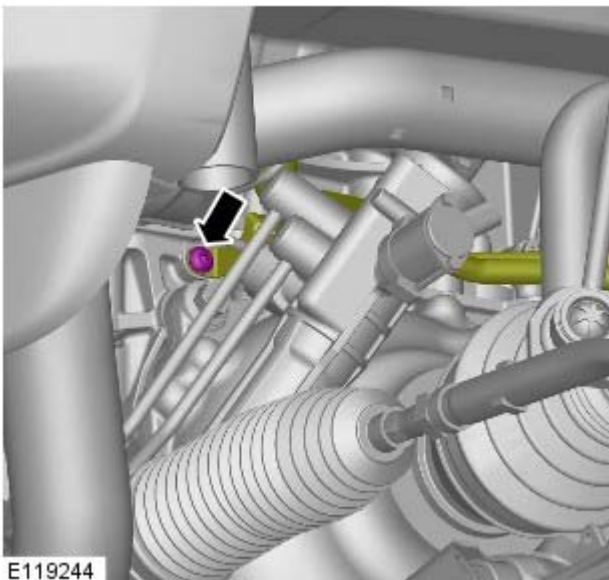

8. **8.** NOTE: Some variation in the illustrations may occur, but the essential information is always correct.

Torque: 10 Nm

9.

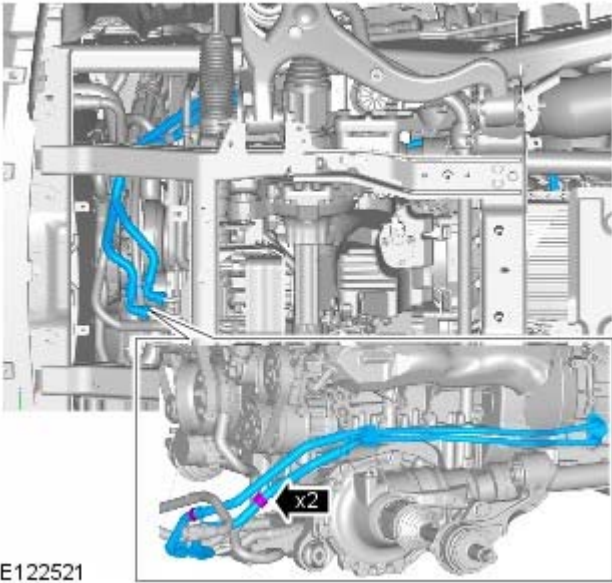

E122521

Installation

1. To install, reverse the removal procedure.

Transmission/Transaxle Cooling - V8 5.0L Petrol/TDV6 3.0L Diesel - Transmission Fluid Cooler TubesTDV6 3.0L Diesel

Removal and Installation

Removal

- NOTE: Removal steps in this procedure may contain installation details.

1.  **WARNING:** Make sure to support the vehicle with axle stands.

Raise and support the vehicle.

2. Refer to: [Engine Undershield](#) (501-02 Front End Body Panels, Removal and Installation).

3. Remove the LH front road wheel.

Torque: 140 Nm

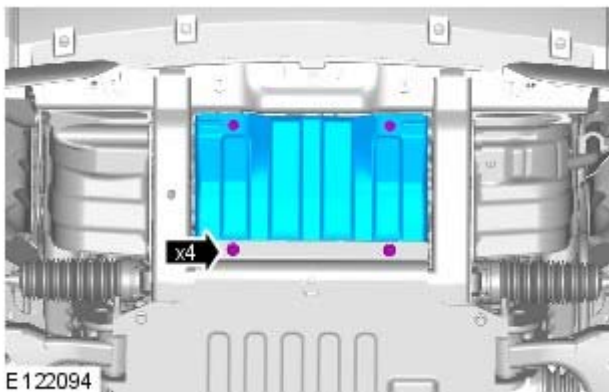

4. *Torque: 10 Nm*

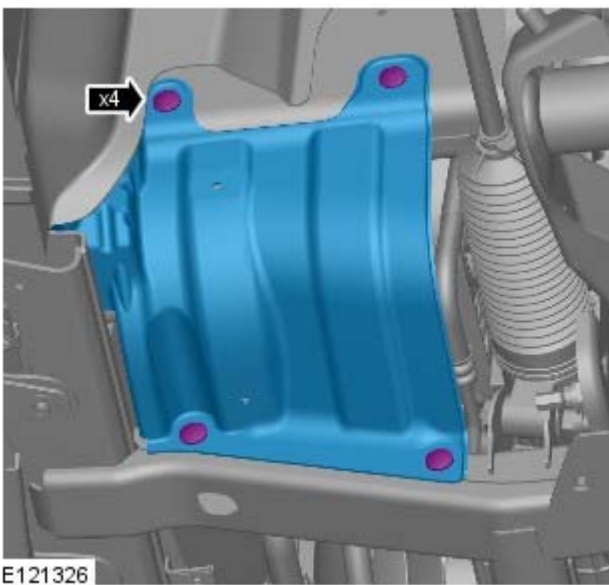

- 5.

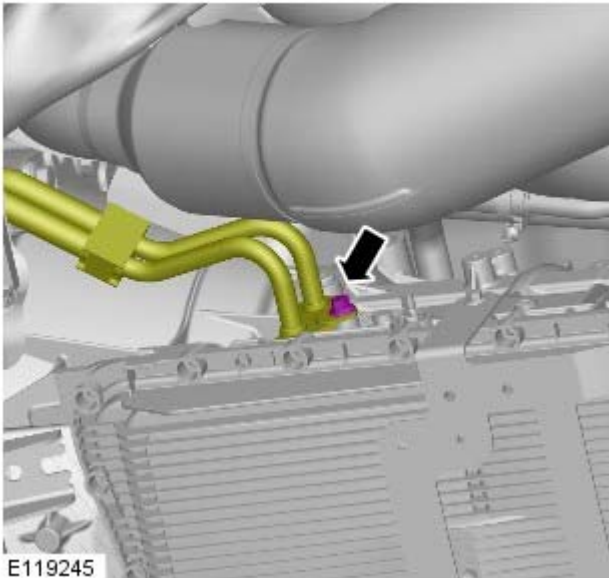

6.  **WARNING:** Be prepared to collect escaping fluids.

 **CAUTION:** Always plug any open connections to prevent contamination.

- **NOTE:** Some variation in the illustrations may occur, but the essential information is always correct.

Torque: 23 Nm

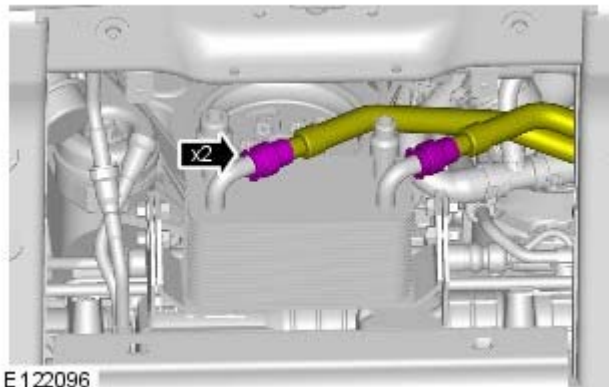

7.  **WARNING:** Be prepared to collect escaping fluids.

 **CAUTION:** Before disconnecting or removing the components, make sure the area around the joint faces and connections are clean and dry. Plug open connections to prevent contamination.

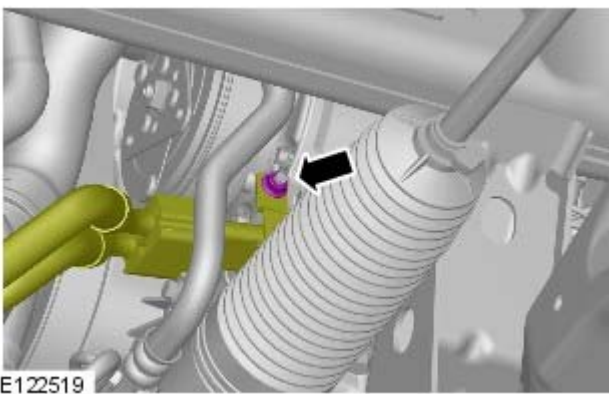

8. *Torque:* 11 Nm

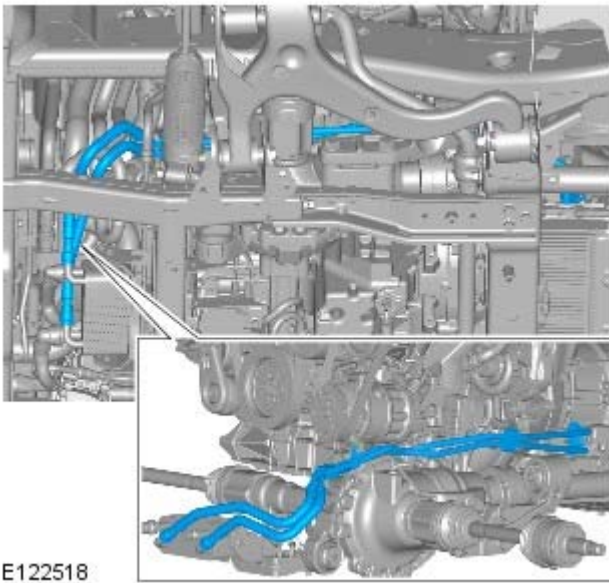

E122518

9.  **WARNING:** Be prepared to collect escaping fluids.

Installation

1. To install, reverse the removal procedure.

Automatic Transmission/Transaxle External Controls - TDV6 2.7L Diesel -

Item	Specification
Type	Cable operated from shift mechanism to bellcrank on side of gearbox with manual release from Park 'P' position in the event of electrical failure

Torque Specifications

Description	Nm	lb-ft
Selector lever locknut	14	10
Transmission heat shield bolts	10	7
Transmission undershield bolts	10	7
Transmission selector nuts	8*	6

*Before VIN257100, discard old fixings and tighten new fixings to the torque value given.

Automatic Transmission/Transaxle External Controls - TDV6 2.7L Diesel - External Controls

Diagnosis and Testing

Principles of Operation

For a detailed description of the automatic transmission/transaxle external controls system and operation, refer to the relevant Description and Operation section of the workshop manual.

Inspection and Verification



CAUTION: Diagnosis by substitution from a donor vehicle is **NOT** acceptable. Substitution of control modules does not guarantee confirmation of a fault, and may also cause additional faults in the vehicle being tested and/or the donor vehicle.

• **NOTE:** Check and rectify basic faults before beginning diagnostic routines involving pinpoint tests.

1. **1.** Verify the customer concern.
2. **2.** Visually inspect for obvious signs of mechanical or electrical damage.

Visual Inspection

Mechanical	Electrical
<ul style="list-style-type: none"> ● Check for correct gear selector lever cable adjustment. REFER to: Selector Lever Cable Adjustment (307-05A Automatic Transmission/Transaxle External Controls - TDV6 2.7L Diesel, General Procedures). ● Visibly worn or damaged components ● Loose or missing fasteners 	<ul style="list-style-type: none"> ● Fuses ● Loose or corroded electrical connectors

3. **3.** If an obvious cause for an observed or reported concern is found, correct the cause (if possible) before proceeding to the next step.
4. **4.** If the cause is not visually evident, check for Diagnostic Trouble Codes (DTCs) and refer to the DTC Index.

DTC Index

For a list of Diagnostic Trouble Codes (DTCs) that could be logged on this vehicle, please refer to Section 100-00.

Automatic Transmission/Transaxle External Controls - TDV6 2.7L Diesel - Selector Lever Cable Adjustment

General Procedures

1.  **WARNING:** The hand brake and foot brake **MUST BE** applied.

Check for correct cable adjustment.

- Move the selector lever from 'P' position, check engagement in each position and return to 'P'.
- Check that the engine will start in 'P' and 'N' positions and that the engine start is inhibited when drive positions are selected.

2.  **WARNING:** Do not work on or under a vehicle supported only by a jack. Always support the vehicle on safety stands.

Raise and support the vehicle.

3. Remove the transmission undershield.

- Remove the 6 bolts.

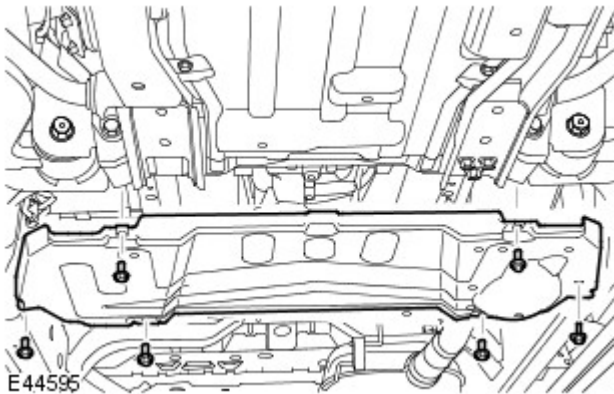

4. If installed, remove the transmission heat shield.

- Remove the 4 bolts.

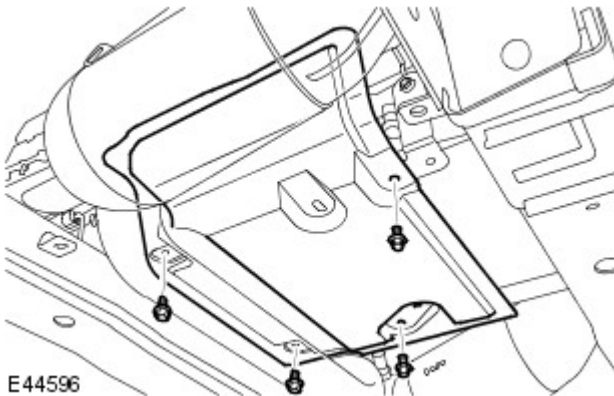

5. Adjust the selector cable.

- Using an additional wrench, restrain the clamping bush and loosen the locknut.
- Move the selector lever on the gearbox fully forward and release it. The lever will return to the 'P' position.
- Make sure the selector lever is in the 'P' position.
- Push the cable inner rearward then release it.
- Tighten the locknut to 14 Nm (10 lb.ft).

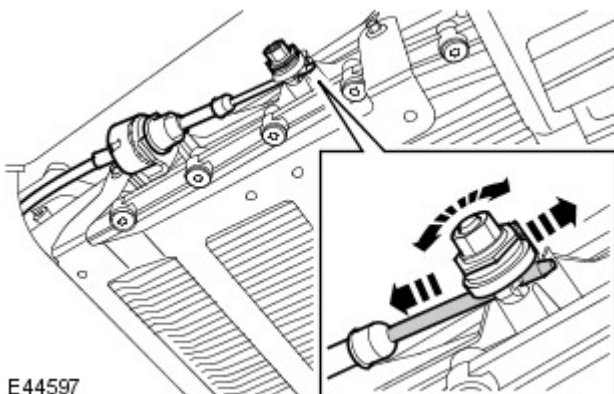

6.  **WARNING:** The hand brake and foot brake **MUST BE** applied.

Check for correct cable adjustment.

- Move the selector lever from 'P' position, check engagement in each position and return to 'P'.
- Check that the engine will start in 'P' and 'N' positions and that the engine start is inhibited when drive positions are selected.

7. If installed, install the transmission heat shield.

- Tighten the bolts to 10 Nm (7 lb.ft).

8. Install the transmission undershield.

- Tighten the bolts to 10 Nm (7 lb.ft).

Automatic Transmission/Transaxle External Controls - TDV6 2.7L Diesel - Selector Lever Assembly

Removal and Installation

Removal

-  **WARNING:** Do not work on or under a vehicle supported only by a jack. Always support the vehicle on safety stands.

Raise and support the vehicle.

- If installed, remove the transmission undershield.
 - Remove the 6 bolts.

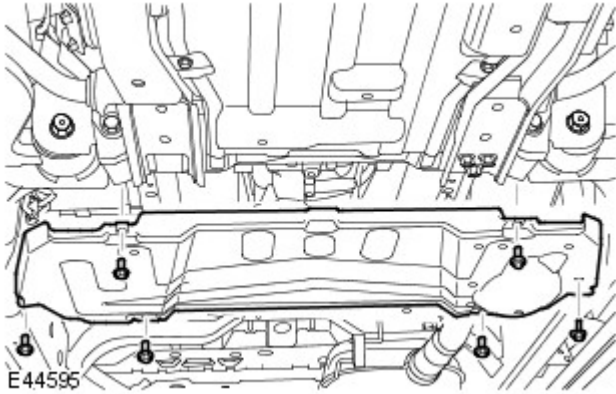

- Remove the transmission heat shield.
 - Remove the 4 bolts.

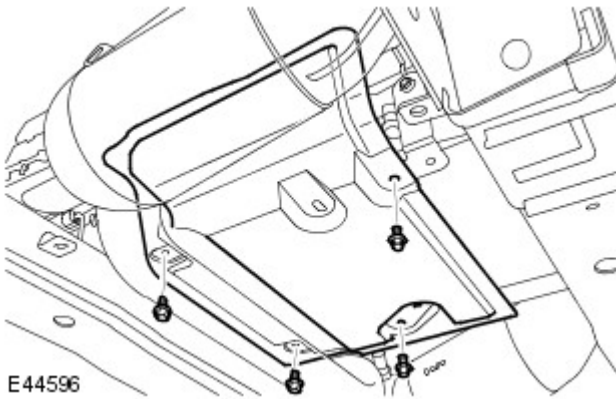

- Release the selector cable.
 - Using an additional wrench, restrain the clamping bush and loosen the locknut.
 - Compress the latch and release the cable.

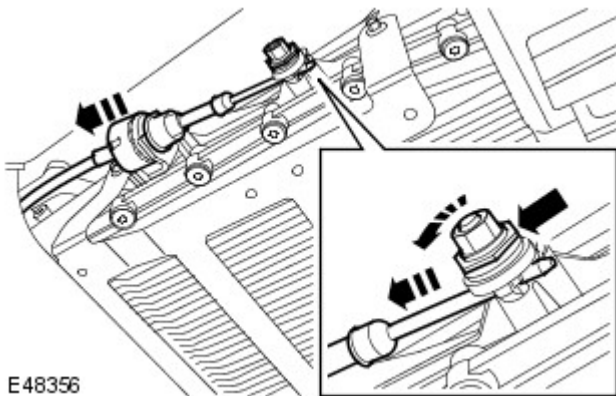

5. Release the selector cable from its guide bracket.

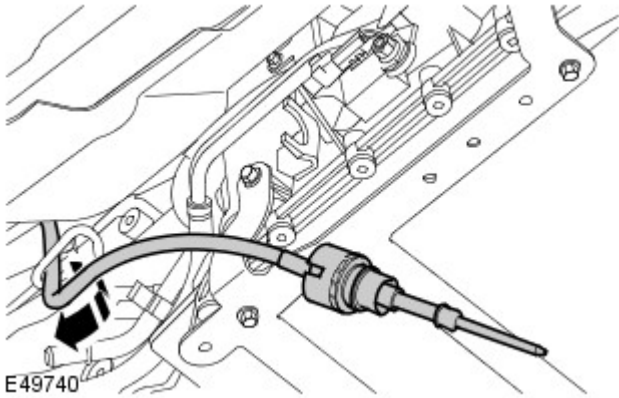

6. Remove the floor console upper trim panel.

7. Remove the transmission selector lever.

- Remove the 3 nuts.
- Disconnect the electrical connector.
- Release the selector cable from the body.

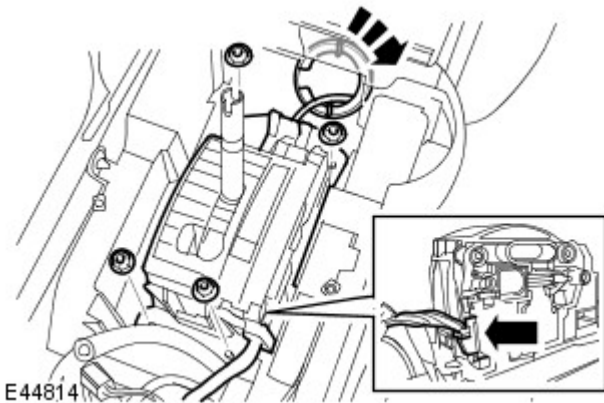

Installation

1. Install the transmission selector lever.

- Secure the cable to the floor.
- Connect the electrical connector.
- Tighten the nuts to 8 Nm (6 lb.ft). Before VIN257100, discard old fixings.

2. **NOTE:** Do not tighten the locking nut at this stage.

Connect the selector cable to the transmission.

- Engage the inner cable with the lever clamping bush.
- Connect the selector cable to its abutment bracket.

3. Position the selector cable to its guide bracket.

4. Install the floor console upper trim panel.

5. Adjust the selector cable.

6. Install the transmission heat shield.

- Tighten the bolts to 10 Nm (8 lb.ft).

7. If installed, install the transmission undershield.

- Tighten the bolts to 10 Nm (8 lb.ft).

Automatic Transmission/Transaxle External Controls - TDV6 2.7L Diesel - Selector Lever Knob

Removal and Installation

Removal

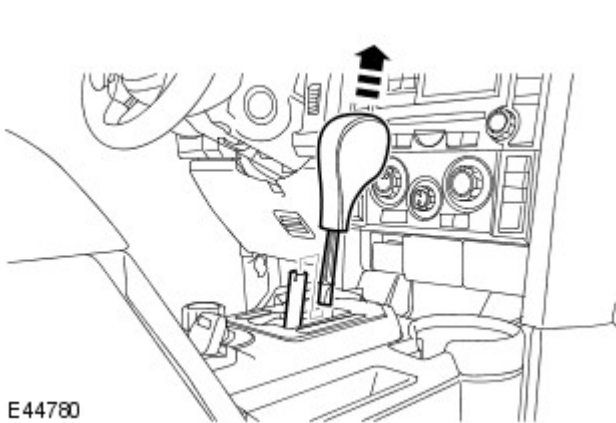

E44780

1.  **WARNING:** The gear lever knob will be released suddenly, keep face clear during removal.

Remove the selector lever knob.

- Pull the knob upwards.

Installation

1.  **CAUTION:** Only fit the selector knob when the selector lever is in the 'P' position.

Install the selector lever knob.

- Engage the locating tang of the knob with the slot in the selector lever.
- Push the knob fully onto the selector lever.

Automatic Transmission/Transaxle External Controls - TDV6 2.7L Diesel - Selector Lever Cable

Removal and Installation

Removal

1.  **WARNING:** Do not work on or under a vehicle supported only by a jack. Always support the vehicle on safety stands.

Raise and support the vehicle.

2. Remove the transmission selector lever.
For additional information, refer to: Shift Selector (307-01, In-vehicle Repair).
3. Remove the selector lever cable.
 - Remove the clip.
 - Release the cable.

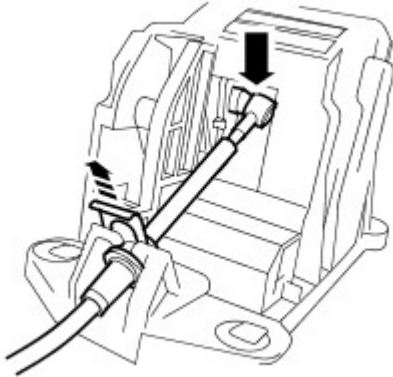

E44788

Installation

1. Install the selector lever cable.
 - Clean the components.
 - Secure the cable.
 - Install the clip.
2. Install the transmission selector lever.
For additional information, refer to: Shift Selector (307-01, In-vehicle Repair).

Automatic Transmission/Transaxle External Controls - TDV6 2.7L Diesel - Selector Lever Gate Finish Panel

Removal and Installation

Removal

1. Remove the selector lever knob.
For additional information, refer to: [Selector Lever Knob](#) (307-05A Automatic Transmission/Transaxle External Controls - TDV6 2.7L Diesel, Removal and Installation).

2. Remove the selector lever gate finish panel.

- Carefully release the gate finish panel.
- Disconnect the 2 electrical connectors.

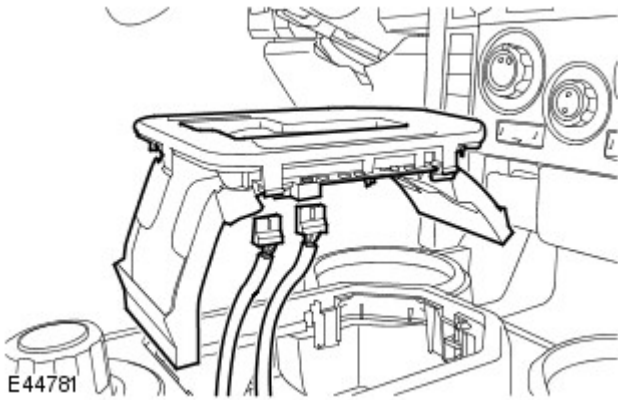

Installation

1. Install the selector lever gate finish panel.

- Connect the electrical connectors.

2. Install the selector lever knob.

For additional information, refer to: [Selector Lever Knob](#) (307-05A Automatic Transmission/Transaxle External Controls - TDV6 2.7L Diesel, Removal and Installation).

Automatic Transmission/Transaxle External Controls - V6 4.0L Petrol -

Item	Specification
Type	Cable operated from shift mechanism to bellcrank on side of gearbox with manual release from Park 'P' position in the event of electrical failure

Torque Specifications

Description	Nm	lb-ft
Transmission heat shield bolts	10	7
Transmission undershield bolts	10	7
Transmission selector nuts	10	7
Transmission selector cable locknut	14	10

Automatic Transmission/Transaxle External Controls - V6 4.0L Petrol - External Controls

Diagnosis and Testing

Principles of Operation

For a detailed description of the automatic transmission/transaxle external controls system and operation, refer to the relevant Description and Operation section of the workshop manual.

Inspection and Verification



CAUTION: Diagnosis by substitution from a donor vehicle is **NOT** acceptable. Substitution of control modules does not guarantee confirmation of a fault, and may also cause additional faults in the vehicle being tested and/or the donor vehicle.

• **NOTE:** Check and rectify basic faults before beginning diagnostic routines involving pinpoint tests.

1. **1.** Verify the customer concern.
2. **2.** Visually inspect for obvious signs of mechanical or electrical damage.

Visual Inspection

Mechanical	Electrical
<ul style="list-style-type: none"> ● Check for correct gear selector lever cable adjustment. REFER to: Selector Lever Cable Adjustment (307-05A Automatic Transmission/Transaxle External Controls - TDV6 2.7L Diesel, General Procedures). ● Visibly worn or damaged components ● Loose or missing fasteners 	<ul style="list-style-type: none"> ● Fuses ● Loose or corroded electrical connectors

3. **3.** If an obvious cause for an observed or reported concern is found, correct the cause (if possible) before proceeding to the next step.
4. **4.** If the cause is not visually evident, check for Diagnostic Trouble Codes (DTCs) and refer to the DTC Index.

DTC Index

For a list of Diagnostic Trouble Codes (DTCs) that could be logged on this vehicle, please refer to Section 100-00.

Automatic Transmission/Transaxle External Controls - V6 4.0L Petrol - Selector Lever Cable Adjustment

General Procedures

1.  **WARNING:** The hand brake and foot brake **MUST BE** applied.

Check for correct cable adjustment.

- Move the selector lever from 'P' position, check engagement in each position and return to 'P'.
- Check that the engine will start in 'P' and 'N' positions and that the engine start is inhibited when drive positions are selected.

2.  **WARNING:** Do not work on or under a vehicle supported only by a jack. Always support the vehicle on safety stands.

Raise and support the vehicle.

3. Remove the transmission undershield.

- Remove the 6 bolts.

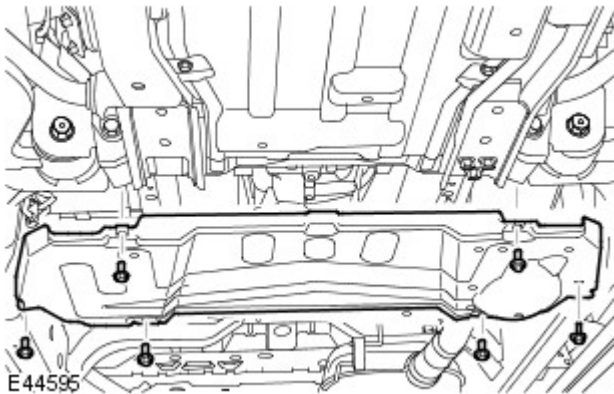

4. If installed, remove the transmission heat shield.

- Remove the 4 bolts.

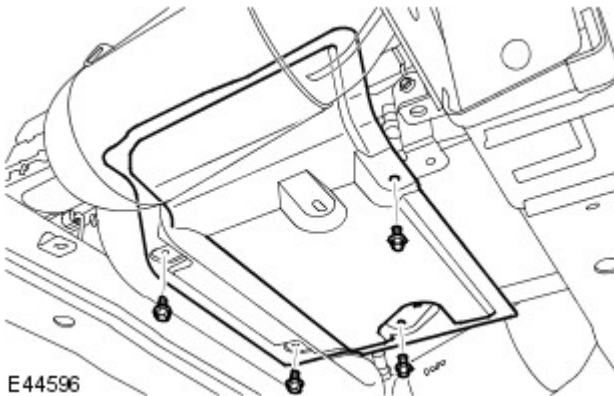

5. Adjust the selector cable.

- Using an additional wrench, restrain the clamping bush and loosen the locknut.
- Move the selector lever on the gearbox fully forward and release it. The lever will return to the 'P' position.
- Make sure the selector lever is in the 'P' position.
- Push the cable inner rearward then release it.
- Tighten the locknut to 14 Nm (10 lb.ft).

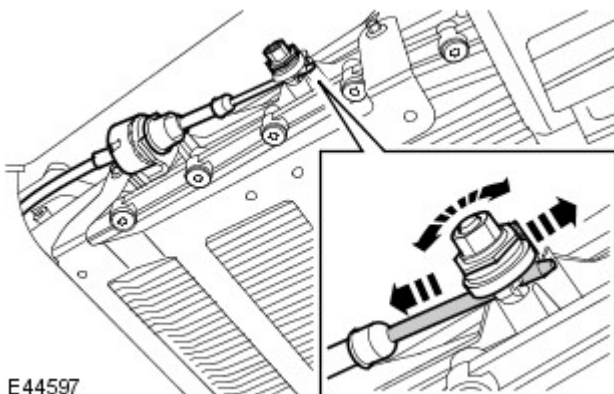

6.  **WARNING:** The hand brake and foot brake **MUST BE** applied.

Check for correct cable adjustment.

- Move the selector lever from 'P' position, check engagement in each position and return to 'P'.
- Check that the engine will start in 'P' and 'N' positions and that the engine start is inhibited when drive positions are selected.

7. If installed, install the transmission heat shield.

- Tighten the bolts to 10 Nm (7 lb.ft).

8. Install the transmission undershield.

- Tighten the bolts to 10 Nm (7 lb.ft).

Automatic Transmission/Transaxle External Controls - V6 4.0L Petrol - Selector Lever Assembly

Removal and Installation

Removal

-  **WARNING:** Do not work on or under a vehicle supported only by a jack. Always support the vehicle on safety stands.

Raise and support the vehicle.

- If installed, remove the transmission undershield.
 - Remove the 6 bolts.

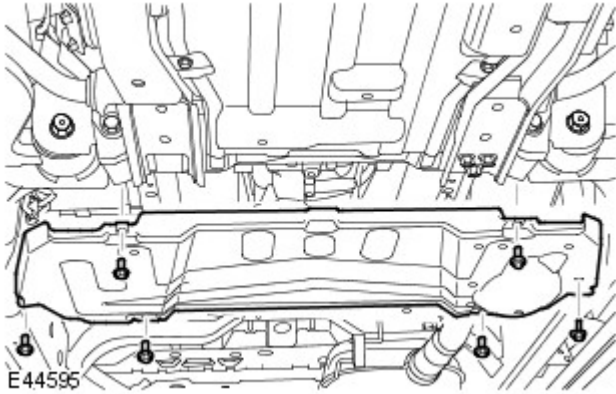

- Remove the transmission heat shield.
 - Remove the 4 bolts.

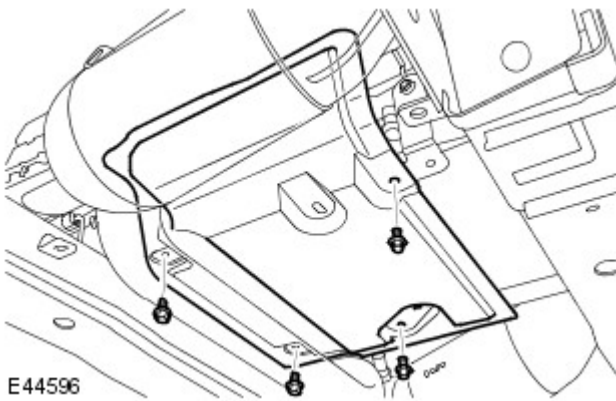

- Release the selector cable.
 - Using an additional wrench, restrain the clamping bush and loosen the locknut.
 - Compress the latch and release the cable.

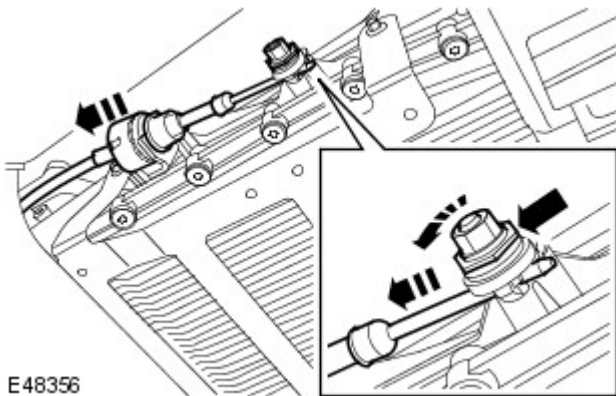

5. Release the selector cable from its guide bracket.

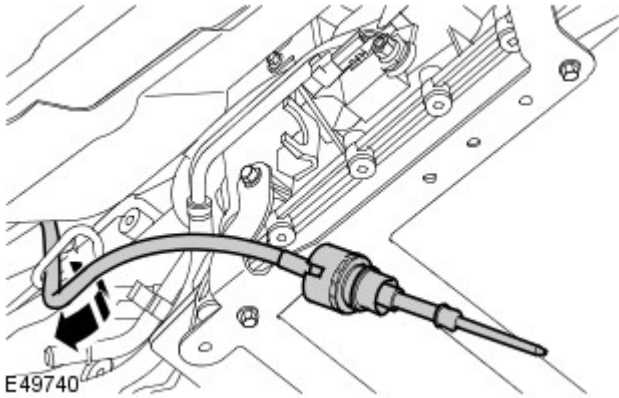

6. Remove the floor console upper trim panel.

7. Remove the transmission selector lever.

- Remove the 3 nuts.
- Disconnect the electrical connector.
- Release the selector cable from the body.

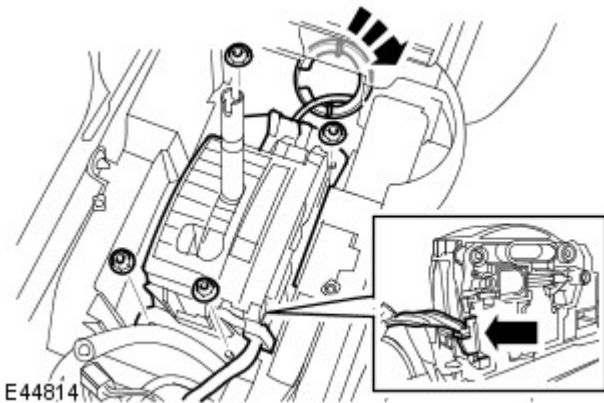

Installation

1. Install the transmission selector lever.

- Secure the cable to the floor.
- Connect the electrical connector.
- Tighten the nuts to 8 Nm (6 lb.ft). Before VIN257100, discard old fixings.

2. **NOTE:** Do not tighten the locking nut at this stage.

Connect the selector cable to the transmission.

- Engage the inner cable with the lever clamping bush.
- Connect the selector cable to its abutment bracket.

3. Position the selector cable to its guide bracket.

4. Install the floor console upper trim panel.

5. Adjust the selector cable.

6. Install the transmission heat shield.

- Tighten the bolts to 10 Nm (8 lb.ft).

7. If installed, install the transmission undershield.

- Tighten the bolts to 10 Nm (8 lb.ft).

Automatic Transmission/Transaxle External Controls - V6 4.0L Petrol - Selector Lever Knob

Removal and Installation

Removal

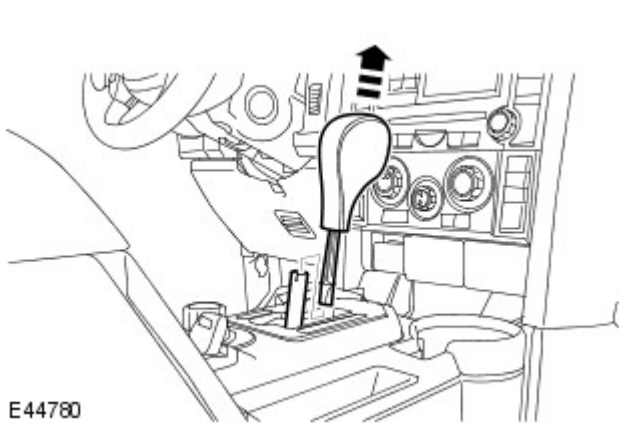

E44780

1.  **WARNING:** The gear lever knob will be released suddenly, keep face clear during removal.

Remove the selector lever knob.

- Pull the knob upwards.

Installation

1.  **CAUTION:** Only fit the selector knob when the selector lever is in the 'P' position.

Install the selector lever knob.

- Engage the locating tang of the knob with the slot in the selector lever.
- Push the knob fully onto the selector lever.

Automatic Transmission/Transaxle External Controls - V6 4.0L Petrol - Selector Lever Cable

Removal and Installation

Removal

1.  **WARNING:** Do not work on or under a vehicle supported only by a jack. Always support the vehicle on safety stands.

Raise and support the vehicle.

2. Remove the transmission selector lever.
For additional information, refer to: Shift Selector (307-01, In-vehicle Repair).
3. Remove the selector lever cable.
 - Remove the clip.
 - Release the cable.

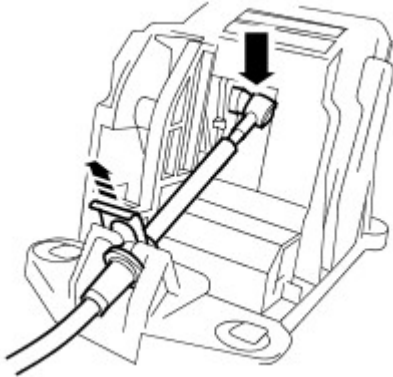

E44788

Installation

1. Install the selector lever cable.
 - Clean the components.
 - Secure the cable.
 - Install the clip.
2. Install the transmission selector lever.
For additional information, refer to: Shift Selector (307-01, In-vehicle Repair).

Automatic Transmission/Transaxle External Controls - V6 4.0L Petrol - Selector Lever Gate Finish Panel

Removal and Installation

Removal

1. Remove the selector lever knob.
For additional information, refer to: [Selector Lever Knob](#) (307-05A Automatic Transmission/Transaxle External Controls - TDV6 2.7L Diesel, Removal and Installation).

2. Remove the selector lever gate finish panel.

- Carefully release the gate finish panel.
- Disconnect the 2 electrical connectors.

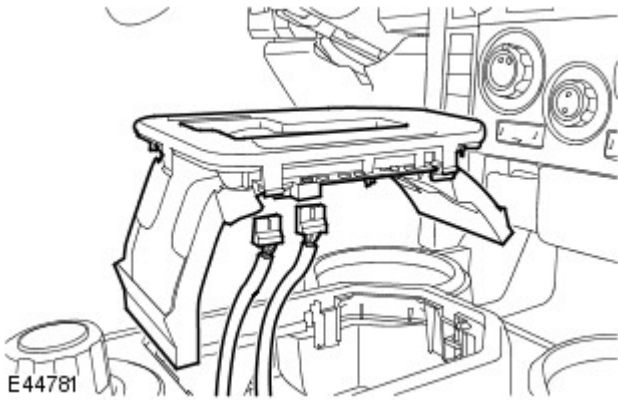

Installation

1. Install the selector lever gate finish panel.

- Connect the electrical connectors.

2. Install the selector lever knob.

For additional information, refer to: [Selector Lever Knob](#) (307-05A Automatic Transmission/Transaxle External Controls - TDV6 2.7L Diesel, Removal and Installation).

Automatic Transmission/Transaxle External Controls - V8 5.0L Petrol/TDV6 3.0L Diesel - External Controls

Description and Operation

COMPONENT LOCATION

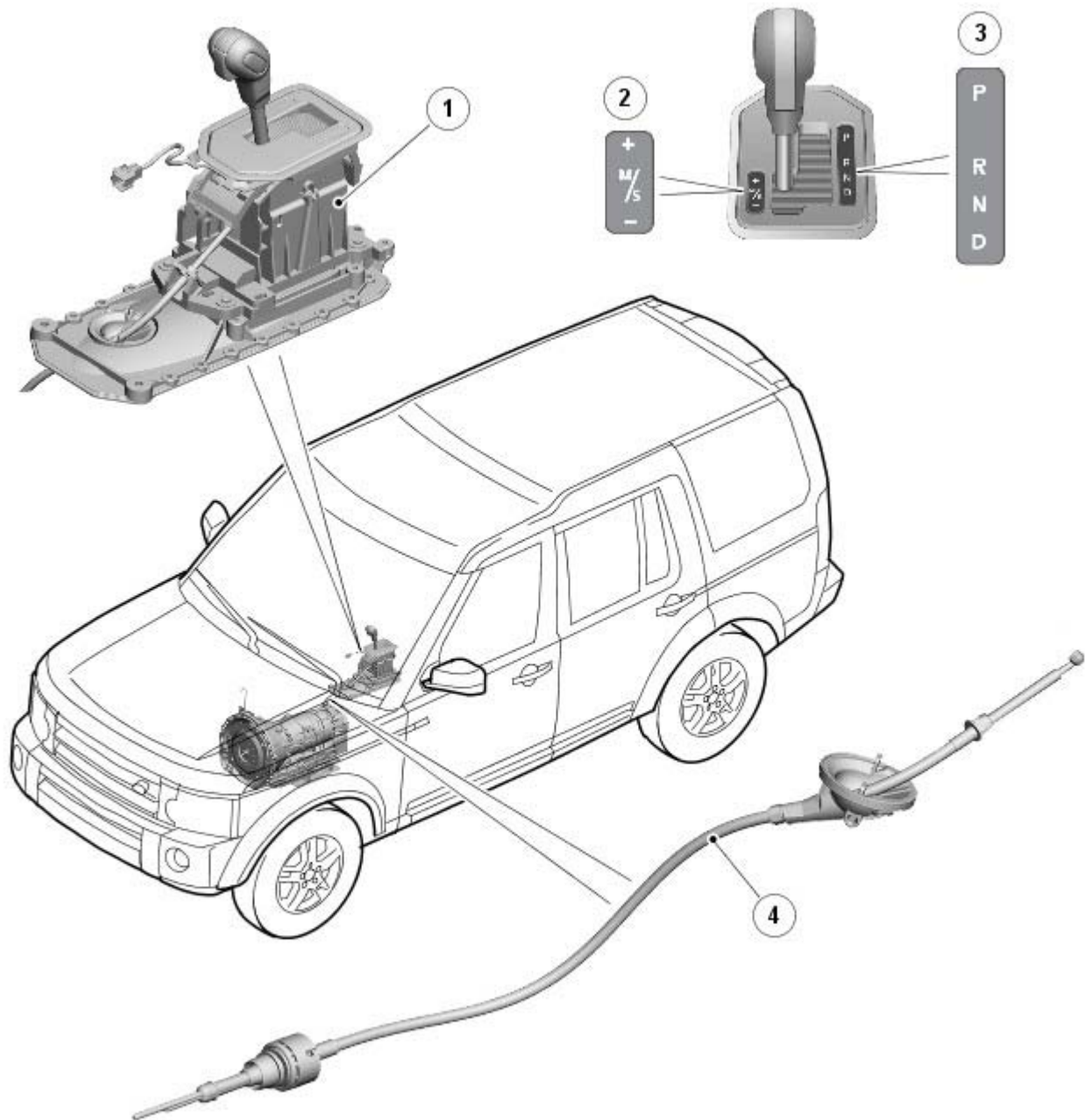

E122602

Item	Part Number	Description
1	-	Selector lever assembly
2	-	M/S (manual/sport) display
3	-	Selector lever position display
4	-	Selector cable

INTRODUCTION

The external controls for the transmission consist of a selector lever assembly and a selector cable.

The selector cable transmits the position of the selector lever to the transmission.

The selector lever position is displayed on the selector lever position display and the M/S (manual/sport) display. The selector lever position and current forward gear are also displayed in the instrument cluster.

For additional information, refer to: [Transmission Description](#) (307-01D Automatic Transmission/Transaxle - V8 5.0L Petrol/TDV6 3.0L Diesel, Description and Operation).

SELECTOR LEVER ASSEMBLY

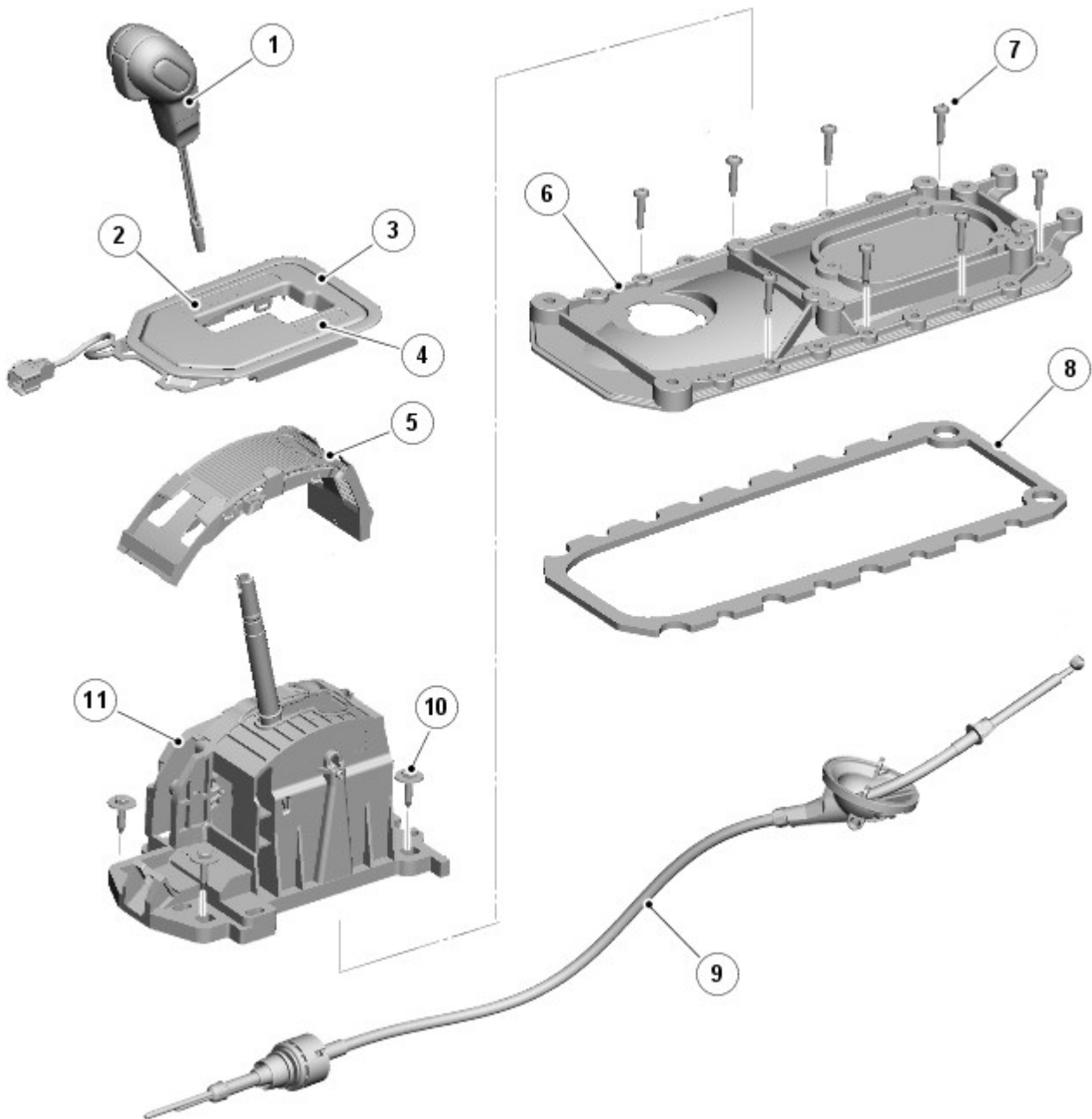

E123732

Item	Part Number	Description
1	-	Selector lever
2	-	Selector lever position display
3	-	Console panel and bezel
4	-	M/S display
5	-	Shutter
6	-	Mounting plate
7	-	Screw (8 off)
8	-	Seal
9	-	Selector cable
10	-	Screw and washer (4 off)
11	-	Interlock emergency release lever and selector assembly

The selector lever assembly is located in the floor console and is secured to the transmission tunnel closure plate. The selector lever assembly comprises a moulded plastic housing which provides for the location of the selector components.

The lever is connected to a crosspiece which allows for the selection of P, R, N, D in a forward and backward direction and selection between D and M/S in a left/right direction.

When M/S (sport) mode is selected the lever can be moved in a forward or backward direction to select + or - for manual (CommandShift®) operation. If left in sport mode, all gear changes are performed automatically.

If manual (CommandShift®) mode is selected, all gear changes are based on inputs received by the [TCM \(transmission control module\)](#) from manual +/- Hall effect sensors located in the selector lever assembly.

The selector lever assembly houses the following components:

- PCB (printed circuit board)
- Shift Interlock solenoid
- Park and Neutral locking levers.

The selector lever positions are as follows:

- P (park) : no torque transmitted to the drive wheels and prevents the vehicle from moving by locking the transmission
- R (reverse) : selects reverse gear - only to be selected when the vehicle is stationary and the engine is at idle
- N (neutral) : no torque transmitted to the drive wheels - allows the vehicle to roll, so ensure the [EPB \(electronic parking brake\)](#) is applied before leaving the vehicle in this state
- D (drive) : this position uses all six forward gears in automatic operation
- M/S : this position engages the sport mode, which uses all six forward gears as in D, but will upshift at higher engine speeds improving acceleration
- + and - : initiates upshifts and downshifts respectively, allowing the transmission to be used as a sequential manual transmission (CommandShift® mode) with six forward gears.

The selector lever position is displayed to the driver on the selector lever position display, M/S display and in the instrument cluster.

Manual/Sport and +/- CommandShift® Sensors

The PCB in the selector lever assembly contains Hall effect sensors to activate the M/S mode and provide the +/- signals.

When the selector lever is moved to the M/S position, the lower magnet located in the selector lever is moved close to the M/S Hall effect sensor on the PCB. This provides a signal for the [TCM](#), which initiates sport mode.

When the selector lever is moved to the + or - position, the magnet is moved close to one of the Hall effect sensors positioned either side of the M/S Hall effect sensor. When an input from either the + or - sensor is received, manual CommandShift® mode is initiated by the [TCM](#). A spring moves the selector lever back to the center position when released. When the selector lever is moved back to the D position, the [TCM](#) returns to normal automatic operation.

Selector Lever Position and Manual/Sport Displays

The displays are incorporated into the console panel on the selector lever assembly. The selector lever position display is located on the [RH \(right-hand\)](#) side of the selector lever and the M/S display is located on the [LH \(left-hand\)](#) side of the selector lever. The two displays are connected to the PCB of the selector lever assembly. An [LED \(light emitting diode\)](#) is installed under the P, R, N and D of the selector lever position display and the M/S of the M/S display. The position of the selector lever is sensed by the PCB, which illuminates the related [LED](#) in the displays.

P, R, N, D Position Switch

The P, R, N, D position switch is located within the Mechatronic valve block in the transmission. The switch is operated by movement of the selector lever to the P, R, N or D positions via the selector cable, which is connected between the selector lever and the transmission selector shaft.

The switch is electrically connected to the [TCM](#), which outputs a common power supply to each of the four switch contacts. This power supply is also used by the two speed sensors and the fluid temperature sensor in the transmission. Each of the four switch contacts have a separate output to the [TCM](#), which enables the [TCM](#) to detect the position of the selector lever.

Shift Interlock Solenoid

The shift interlock solenoid is located on the side of the selector lever assembly. The solenoid is connected to two locking levers, which engage with the base of the selector lever and lock it in the P and N positions when the solenoid is de-energized. Operation of the solenoid is controlled by the [TCM](#).

When the ignition is on and the brake pedal is pressed, the [TCM](#) energizes the solenoid and the selector lever can be moved from the P or N position. This prevents the selector lever from being moved to the D or R position unintentionally, and the application of the brakes prevents the vehicle 'creeping' when the transmission engages gear.

Movement of the selector lever from the P or N positions is prevented if the [TCM](#) senses the engine speed is above 2500 rev/min, even if the brake pedal is pressed.

The selector lever is locked in the N position during the transfer box changing range from high to low or vice versa.

If there is a vehicle electrical failure, or failure of the interlock solenoid or associated wiring, it is possible to move the selector lever from the P position by removing the selector lever, and the switch pack and finisher, and lifting the white tab on the rear of the selector lever assembly. While holding the tab in this position, the selector lever can be moved from the P position.

SELECTOR CABLE

The selector cable is used as a mechanical connection between the selector lever and the transmission. The cable is a Bowden cable. Movement of the selector lever between the P, R, N and D positions moves the cable. Movement of the cable is prevented when the selector lever is in the M/S position.

A seal is installed on the cable where it passes through the mounting plate. The outer cable is attached to a bracket on the transmission. The inner cable is connected to a lever attached to the transmission selector shaft.

Movement of the selector lever between the P, R, N and D positions moves the inner cable, which moves the lever. The lever transforms the linear movement of the cable into rotary movement of the selector shaft, which operates the P, R, N, D position switch and a spool valve in the Mechatronic valve block.

CONTROL DIAGRAM

• NOTE: A = Hardwired; D = High speed CAN (controller area network) bus.

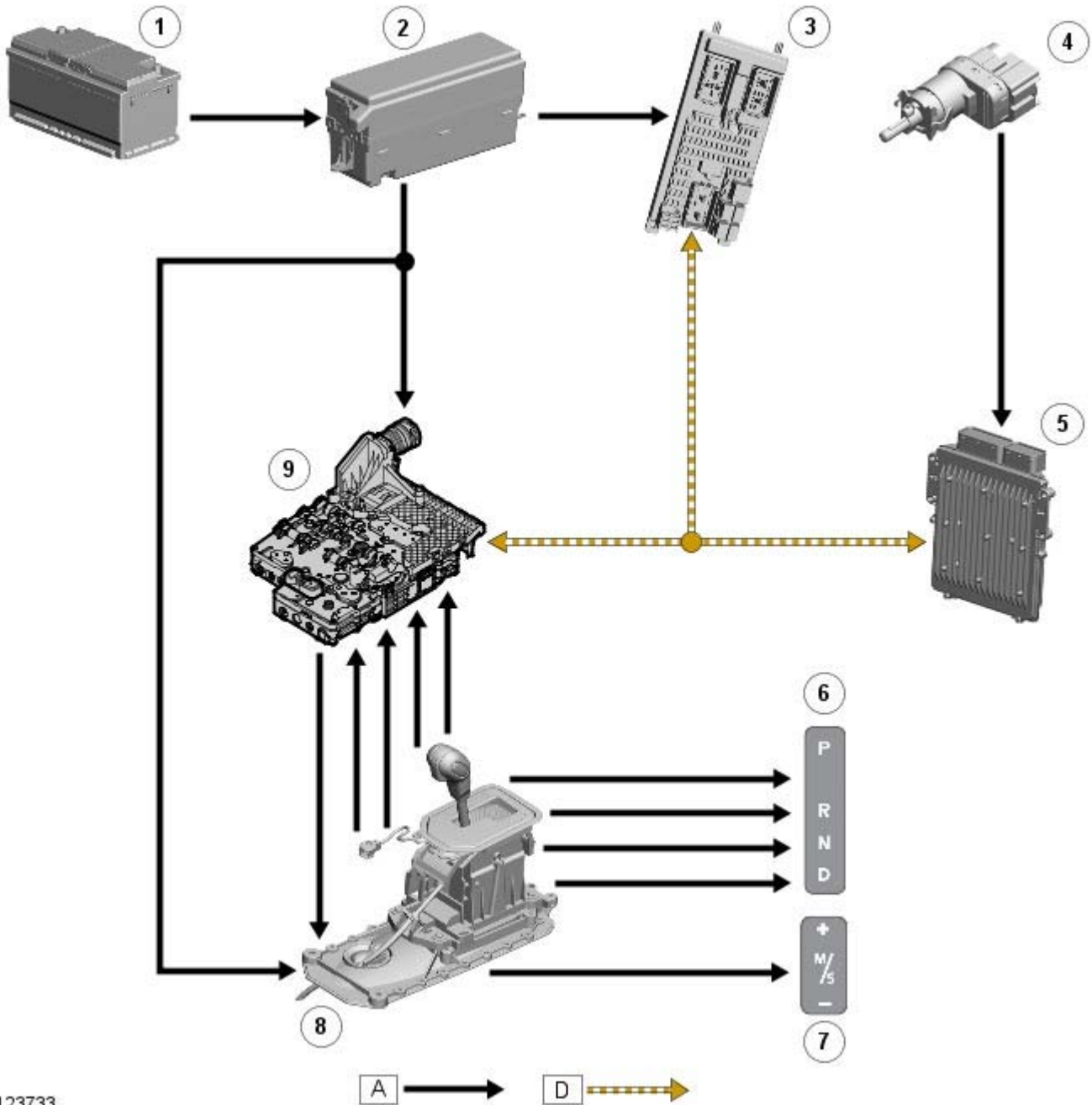

E123733

Item	Part Number	Description
1	-	Battery
2	-	EJB (engine junction box) (50 A megafuse)
3	-	CJB (central junction box) (ignition relay)
4	-	Stoplamp switch
5	-	ECM (engine control module)
6	-	Selector lever position display
7	-	M/S display
8	-	Selector lever assembly
9	-	TCM/Mechatronic valve block

Automatic Transmission/Transaxle External Controls - V8 5.0L Petrol/TDV6

3.0L Diesel - External Controls

Diagnosis and Testing

Principles of Operation

For a detailed description of the automatic transmission/transaxle external controls system and operation, refer to the relevant Description and Operation section of the workshop manual.

Inspection and Verification



CAUTION: Diagnosis by substitution from a donor vehicle is **NOT** acceptable. Substitution of control modules does not guarantee confirmation of a fault, and may also cause additional faults in the vehicle being tested and/or the donor vehicle.

• **NOTE:** Check and rectify basic faults before beginning diagnostic routines involving pinpoint tests.

1. **1.** Verify the customer concern.
2. **2.** Visually inspect for obvious signs of mechanical or electrical damage.

Visual Inspection

Mechanical	Electrical
<ul style="list-style-type: none"> ● Check for correct gear selector lever cable adjustment. REFER to: Selector Lever Cable Adjustment (307-05A Automatic Transmission/Transaxle External Controls - TDV6 2.7L Diesel, General Procedures). ● Visibly worn or damaged components ● Loose or missing fasteners 	<ul style="list-style-type: none"> ● Fuses ● Loose or corroded electrical connectors

3. **3.** If an obvious cause for an observed or reported concern is found, correct the cause (if possible) before proceeding to the next step.
4. **4.** If the cause is not visually evident, check for Diagnostic Trouble Codes (DTCs) and refer to the DTC Index.

DTC Index

For a list of Diagnostic Trouble Codes (DTCs) that could be logged on this vehicle, please refer to Section 100-00.