



FREELANDER 2

OWNER'S HANDBOOK

Publication Part No. LRL 10 02 56 702

This handbook forms part of the Owner literature supplied with your new vehicle. Left-hand drive and right-hand drive conditions may be shown in the graphics and where information is specific to a particular country, it is indicated as such.

The **Quick start** section is designed to rapidly familiarise the driver with the initial set up and also explain some of the unique features. Please take the time to study the operating instructions with your vehicle as soon as you can.

Important

The information contained in this handbook covers all vehicle derivatives and optional equipment. Some of the options may not be fitted to your vehicle unless they formed part of the original vehicle specification. Therefore some parts of this handbook may not apply to your vehicle. Furthermore, due to printing cycles, it may include descriptions of options before they become generally available.

The information contained in this publication was correct when it went to print. Vehicle design changes may have been made after this handbook was printed. When this occurs a handbook supplement is added to the literature pack. Subsequent updates can be viewed on the Land Rover Internet site at; **www.ownerinfo.landrover.com**.

In the interest of development, the right is reserved to change specifications, design or equipment at any time without notice and without incurring any obligations. This publication, or part thereof, may not be reproduced nor translated without our approval. Errors and omissions excepted.

© Land Rover 2007

All rights reserved.

Published by Land Rover Technical Communications.

Quick start

QUICK START

Remote control

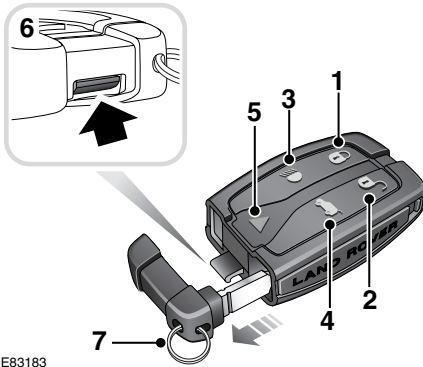

E83183

1. Lock button.

Press once to lock the vehicle and arm the alarm. Press twice within three seconds to double lock the vehicle. Press and hold to close the door windows (Global closing).

2. Unlock button.

Press once to disarm the alarm, unlock the driver's door and unlock the luggage compartment. Press again to unlock the passenger doors. Press and hold to open the door windows (Global opening).

3. Approach lighting button.

Press once to switch the headlamps, position lamps, and license plate lamps on for a short period. Press again to switch off. See **APPROACH LAMPS** (page 76).

4. Tailgate release.

Press to release the tailgate.

5. Panic alarm.

Press twice in three seconds, or press and hold for two seconds, to activate the **panic alarm**. After five seconds, press and hold the button again to cancel the alarm.

6. Press the release tab on the remote control to release the emergency key blade.

7. Pull the keyring attachment to remove the key blade.

Single point entry

This is a security feature that unlocks only the driver's door, fuel filler flap, and tailgate. It can be disabled on individual remote controls by unlocking the vehicle then simultaneously pressing and holding the lock and unlock buttons for three seconds. The vehicle will lock and then unlock in the currently selected mode and the hazard warning lights will flash twice to confirm the change.

You can now unlock all doors with a single press. Repeating the procedure will re-enable Single point entry.

Further information is available within the main body of the handbook. See **USING THE REMOTE CONTROL** (page 41).

Quick start

Engine starting



E83184

The **START STOP ENGINE** button 2 is only operational when a recognised remote control is inserted into the starter control unit 1 (buttons facing upwards).

When inserted, the remote control will latch into the starter control unit. To remove, press the remote control to unlatch and release.

Remote control unit removal

Press the remote control to unlatch and release from the starter control unit. Remove by gripping the sides of the remote control.

Ignition only

- Press and hold the **START STOP ENGINE** button for a short period, to switch on the ignition.
- Pressing the button again will switch off the ignition.

Engine start/stop

- For automatic transmission vehicles, with the gear selector in **P** (park) or **N** (neutral) and the brake pedal depressed, press and release the **START STOP ENGINE** button to start the engine.
- For manual transmission vehicles, depress the clutch pedal and press and release the **START STOP ENGINE** button to start the engine.
- Press the button again to stop the engine and switch off the ignition.

Quick start

Master lock and unlock switches

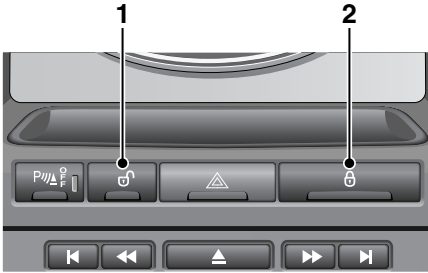

E83185

1. Press and hold to unlock all doors and tailgate.
2. Press and hold to lock all doors and tailgate.

Press both **1** and **2** to release the tailgate.

Tailgate

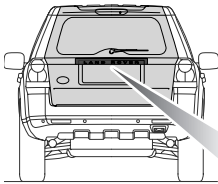

E83186

With the vehicle unlocked, press the release switch on the underside of the exterior handle and pull to open.

Bonnet

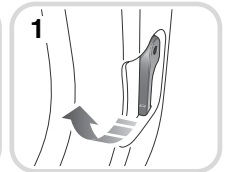
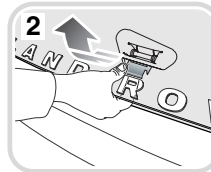
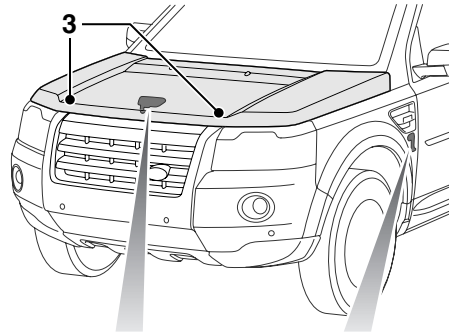

E83187

Opening

Pull the bonnet release lever **1**.

Lift the bonnet safety catch lever **2**, and raise the bonnet.

Closing

Lower the bonnet until the safety catch engages. Using both hands, press the bonnet down until the catches click.

Check that both catches **3** are engaged by trying to lift the front edge of the bonnet.

Quick start

Power operated seat adjustment

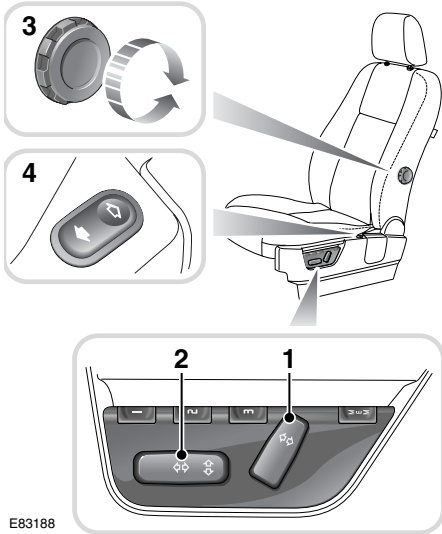

E83188

1. Backrest adjustment switch.
2. Seat forward/backwards and cushion height control switch.
3. Lower backrest lumbar support handwheel (non-memory seats).
4. Lower backrest lumbar support switch (driver's side memory seat only).

Wherever possible the seats should be adjusted with the engine running. In addition, the seats have an active period that is initiated when the driver's door is opened and closed or the remote control is removed from the docking port.

Driving position memory

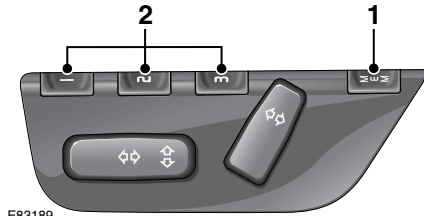

E83189

Once you have adjusted the power operated driver's seat and exterior mirrors for your ideal driving position, the vehicle can memorise these settings for future use.

To operate the windows and door mirrors, the remote control must be in the docking port and the ignition on.

1. Press the memory store button to activate the memory function.
2. Press one of the preset buttons within five seconds to memorise the current settings. **MEMORY STORED** will be displayed on the message centre accompanied by an audible chime to confirm the settings have been memorised.

Operating note

A seat position will only be memorised during the five second active period.

Any existing settings will be over-written when programming a memory position.

Quick start

Manual seat adjustment

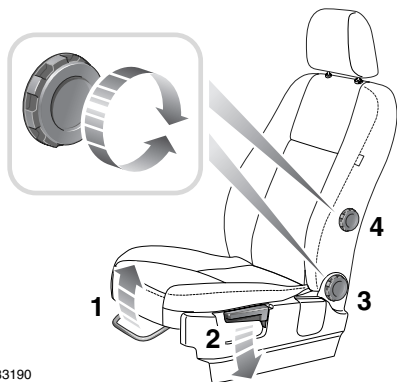

E83190

1. Forward/backward adjustment.
2. Height adjustment.
3. Backrest adjustment.
4. Lumbar adjustment.

Windows and Door mirrors

To operate the windows and door mirrors, the remote control must be in the docking port and the ignition on.

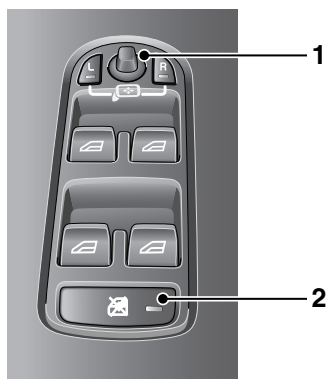

E83191

Windows

- To open a window, press and hold the respective switch.

- To close the window, pull and hold the switch.

Window movement can be stopped at any time by releasing the switch.

The windows have a one touch facility that allows them to be fully opened or closed with a single operation of the switch. Press or pull the switch and release. Movement can be stopped by briefly pressing the switch again.

Press switch **2** to inhibit the operation of the rear window switches.

Resonance with lowered windows

If a resonance/booming sound occurs when a window is open, lowering an adjacent window about 25 mm (1 inch) will eliminate the condition.

Door mirror adjustment

To adjust the mirrors, press the **L** (Left) or **R** (Right) button to select the appropriate mirror. Move the control knob **1** in any direction to adjust the position of the mirror glass.

Power fold mirrors

The mirrors can be electrically folded towards the door for better clearance/protection.

Press the **L** and **R** buttons simultaneously to fold/unfold the mirrors.

The mirrors may also fold automatically when the vehicle is locked, and unfold when the vehicle is unlocked.

Reverse automatic mirror dip

When reverse gear is selected, the door mirrors will dip.

The dip position of the door mirrors can be personalised. See **ELECTRIC EXTERIOR MIRRORS** (page 95).

This feature can be disabled or enabled by a Land Rover Dealer/Authorised Repairer.

Quick start

Steering column adjustment

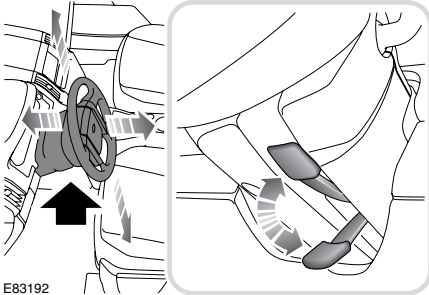

1. Move the lever located under the steering wheel fully downward.
2. Adjust the height and reach of the steering wheel to the desired position.
3. Move the lever fully up to lock the position of the wheel.

Steering column lock

The vehicle has an electronic steering column lock that is deactivated when the remote control is inserted in the docking port.

Overhead console

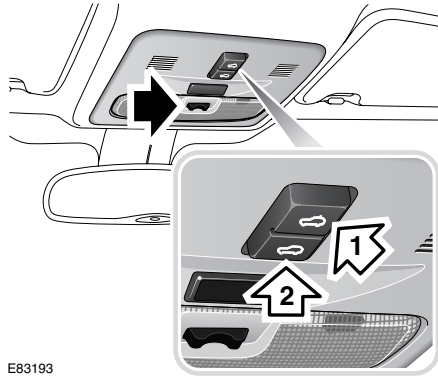

Courtesy lamps

The front and rear courtesy lamps will operate in conjunction with the vehicle being unlocked/locked or when a door is opened.

The courtesy lamps can be manually switched on or off by the lamp switch (arrowed in the illustration). When the switch is in the centre position, the lamps operate in automatic mode.

Panoramic sunroof

To tilt the sunroof:

1. Press and release the front of the switch **2** to open the sunroof to the tilt position.

To open the sunroof:

1. Press and release the rear of the switch **1** to fully open the sunroof.

To close the sunroof:

1. From the fully open position, press and release the front of the switch **2**.
2. From the tilted position, press and hold the rear of the switch **1**.

If the sunroof is moving, it can be stopped by pressing the switch again.

Quick start

Operating note

The sunroof can only be operated with the ignition on.

Seat belts and Child restraints



A warning indicator on the instrument pack will illuminate to alert you that the driver's or front passenger's seat belt is unbuckled.

Child seats

It is important to remember that the child's weight, rather than age, determines the type of seat that is required. See **CHILD SEATS** (page 64).

Recommended child seat

Land Rover strongly recommend the use of ISOFIX child seats.

ISOFIX child seats can only be fitted in the rear outer seating positions.

Passenger airbag deactivation

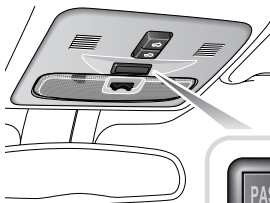
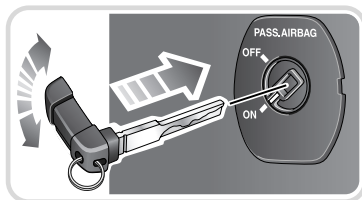

E83194

WARNING



Do not use a child restraint on a seat protected by an operational airbag in front of it. There is a risk of death or serious injury when the airbag deploys.

If it becomes necessary to fit a child restraint on the front passenger seat, the passenger airbag must be deactivated.

To deactivate the airbag, open the front passenger door and use the starter key to turn the **PASS AIRBAG** switch (located on the end of the facia) to the **OFF** position.

With the airbag deactivated, the status indicator, located on the overhead console, will illuminate whenever the ignition is on.

Operating note

When an adult is seated in the front passenger seat, ensure the **PASS AIRBAG** switch is turned to the **ON** position.

Quick start

Heating and ventilation

Automatic system

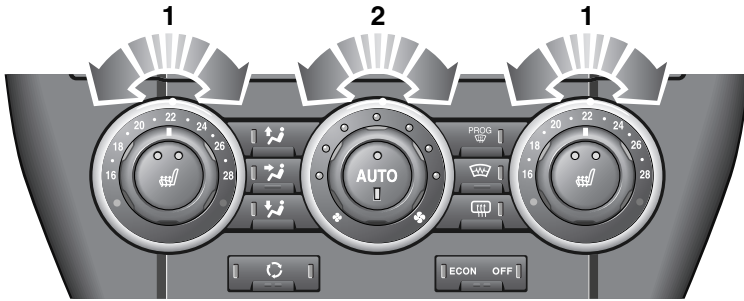

E83195

Manual system

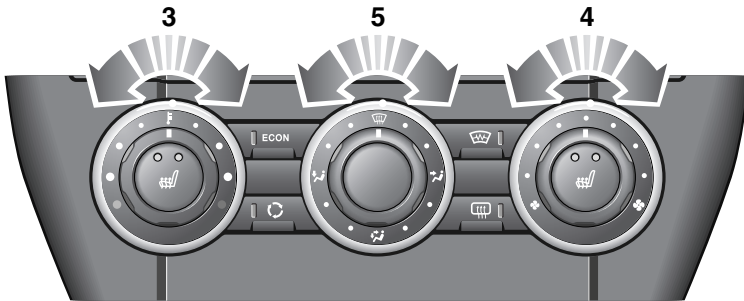

E83196

These are the primary functions of the heating and ventilation system. Dependent upon specification, the control panel may differ from those shown.

Air conditioning

Air conditioning is an integral part of the heating and ventilation system, providing cooled and dehumidified air for occupant comfort. The dry airflow is effective in preventing misting of windows and is also beneficial at low external temperatures.

Air conditioning is automatically switched on and controlled whenever the system is not operating in **ECON** mode.

External water deposits

The air conditioning system removes moisture from the air and deposits excess water beneath the vehicle. Puddles may form, but this is no cause for concern.

Auto mode (Automatic systems)



Press **AUTO** to select automatic operation of the system, both LEDs in the switch will illuminate.

The system will adjust the heat output, blower speed, air intake and airflow distribution to maintain the selected temperature(s) and reduce misting without further adjustments.

Quick start

The air distribution and blower controls can be operated to override the automatic settings. This will extinguish the appropriate LED in the **AUTO** control.

Recommended mode

Select **AUTO** as the normal operating mode. This will help prevent window misting and odours from the climate control system.

Temperature selection (Automatic system)

Rotate the control **1** to adjust the temperature for the respective side of the passenger compartment.

Operating note

On the automatic system, it is not possible to achieve a temperature differential of more than 4°C (7°F) between the left and right.

Blower speed (Automatic systems)

Rotate the blower control **2** to adjust airflow through the vents. LEDs will illuminate to indicate which of the eight possible speeds is currently selected.

Air distribution control (Automatic systems)

Press to select the desired distribution setting. An LED will illuminate in the switch.



Front screen and side window vents



Face level vents



Foot level vents

More than one setting can be selected to achieve the desired distribution.

Off (Automatic systems)



Press to switch the system off. An LED will illuminate in the switch to show this condition.

Press again to return the system to its previous operating mode. The system will also be reactivated by using the **AUTO**, blower speed, air distribution or defrost controls.

Defrost mode (Automatic systems)



Press to remove frost or heavy misting from the front screen. The system will automatically adjust the

blower output for maximum clearing, in addition the front and rear screen heaters will be activated.

Press again to switch off defrost mode. The screen heaters will remain on.

Heated screens



Press to operate. An LED in the switch will illuminate whilst operating.



The heaters will automatically switch off after a preset interval.

Air recirculation



Press once to activate air recirculation. An LED will illuminate in the switch. Press again to return to fresh air intake.

Economy mode



Press to put the system into economy mode. An LED will illuminate in the switch to show this condition.

In economy mode air conditioning is switched off. This reduces the load on the engine, thereby improving fuel consumption.

Quick start

Seat heaters



Press the relevant button to operate the required seat heater at high level. Both LEDs will illuminate.

Press a second time to heat the seat at a lower level. One LED will extinguish.

Press a third time to switch off.

Temperature selection (Manual system)

Rotate the control **3** to adjust the air temperature entering the passenger compartment.

Blower speed (Manual system)

Rotate the blower control **4** to adjust airflow through the vents. As the control is adjusted, LEDs will illuminate to indicate which of the eight possible speeds is currently selected.

Air distribution control (Manual system)

Rotate the control **5** to achieve the desired air distribution setting.



Front screen and side window vents



Face level vents



Foot level vents



Foot and face level vents

Note: It is possible to distribute air to two areas simultaneously. For example; to distribute air to both the windscreen and the foot vents set the rotary control (**5**) to a point between the windscreen and foot vent symbols.

Quick start

Facia

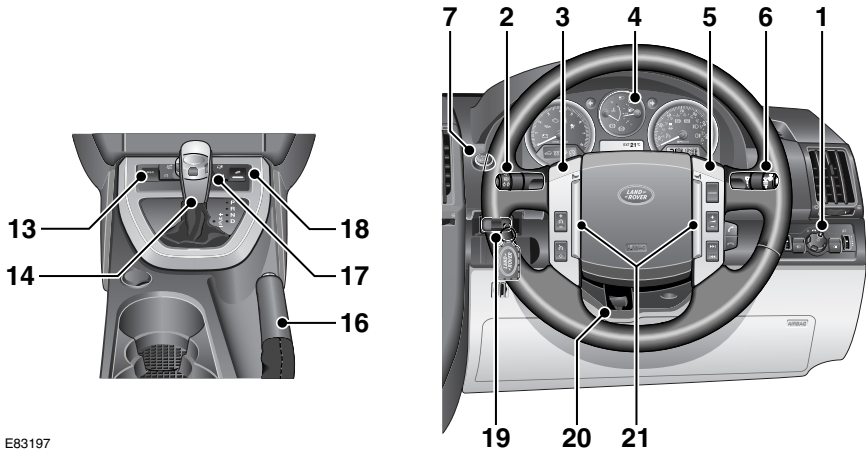
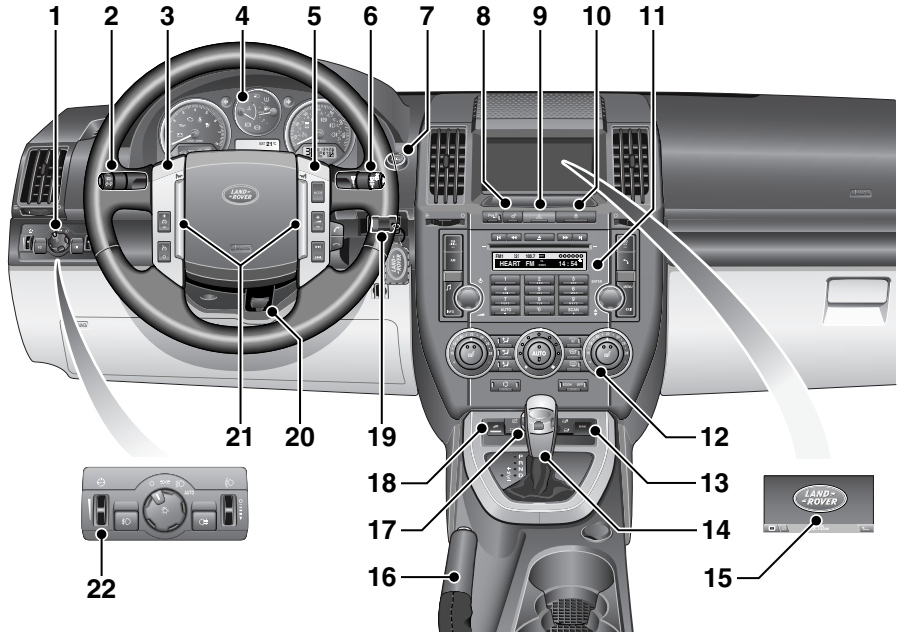

E83197

Quick start

1. Exterior lamps master switch
2. Direction indicators/headlamps/trip computer switch
3. Cruise control switches
4. Instrument pack
5. Audio/telephone switches
6. Washer/wiper switch
7. Start stop engine button
8. Master unlock switch
9. Hazard warning switch
10. Master lock switch
11. Audio unit
12. Heater/air conditioning controls
13. Dynamic Stability Control (DSC) switch
14. Gear selector
15. Touch screen
16. Parking brake
17. Terrain Response control switch
18. Hill Descent Control (HDC) switch
19. Starter control unit
20. Steering column adjustment lever
21. Horn switches
22. Facia illumination dimmer control

Quick start

Instrument pack

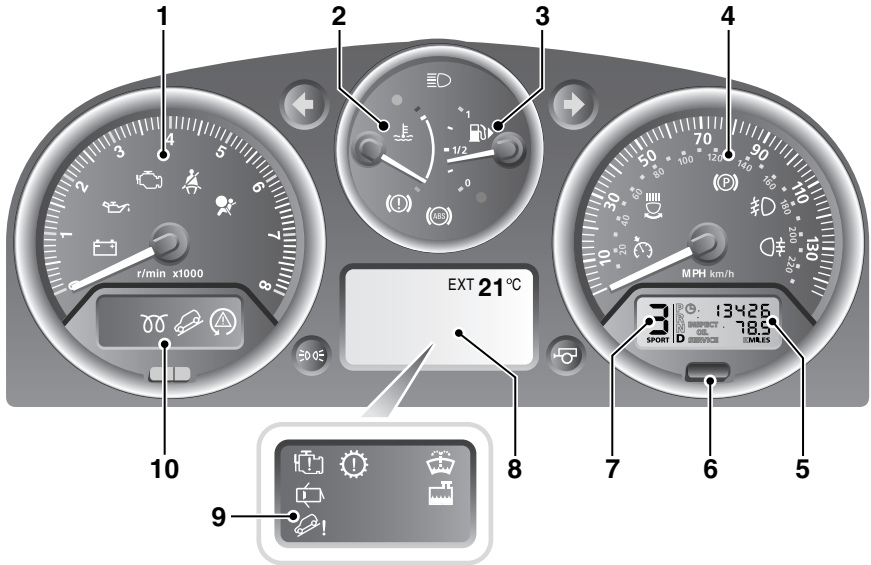

E83375

1. Tachometer
2. Temperature gauge
3. Fuel gauge
4. Speedometer
5. Total distance (odometer) and trip recorder
6. Trip recorder reset switch
7. Gear selector mode and position display
8. Main message centre
9. Warning indicators panel
10. Tachometer indicators panel

Quick start

Tachometer

Indicates engine speed in revolutions per minute (x 1 000). In normal driving conditions the engine is most fuel efficient between 2 000 and 3 000 rev/min.

Temperature gauge

At normal operating temperature, the pointer is positioned midway between the red and blue segments of the gauge (the precise position will vary according to climatic conditions).



E80509

If the pointer moves into the red segment and the red warning indicator (arrowed) illuminates, severe engine damage could occur (under these circumstances the air conditioning may switch off and engine performance may reduce to minimise engine load).

If the engine overheats, stop the vehicle as soon as safety permits. Switch the engine off and allow it to cool down. If the problem reoccurs, seek qualified assistance before continuing.

Fuel gauge

CAUTION



Never allow your vehicle to run out of fuel as the resultant misfire may destroy the catalytic converter.

When the ignition is on the pointer quickly rises to show the level of fuel in the tank.



E80510

When the amber low fuel warning indicator (arrowed) illuminates, the remaining fuel should give a range of 80 km (50 miles). The small arrow alongside the fuel pump symbol indicates the side of the vehicle on which the fuel filler is located.

Total distance (odometer) and trip recorder

Indicates the total distance travelled, and also shows the most recent individual journey distance.

Trip recorder reset switch

With the ignition on, press to reset the trip recorder back to zero.

Selected gear display

Displays the currently selected gear and operating mode.

Quick start

Warning indicators (attention)

If any of the following illuminates whilst driving a fault has been detected. Refer to the individual pages given below for further information.



Battery charge indicator. See **GENERAL DRIVING POINTS** (page 128).



Low oil pressure. See **GENERAL DRIVING POINTS** (page 128).



Parking brake. See **PARKING BRAKE** (page 124).



Brake systems. See **PRINCIPLE OF OPERATION** (page 123).



Anti-lock braking system. See **HINTS ON DRIVING WITH ABS** (page 123).



Airbag system. See **AIRBAG WARNING LAMP** (page 61).



Engine management system. See **REDUCED ENGINE PERFORMANCE** (page 128).



Engine. See **REDUCED ENGINE PERFORMANCE** (page 128).



Transmission. See **MANUAL TRANSMISSION** (page 118).



Hill Descent Control (HDC). See **PRINCIPLE OF OPERATION** (page 136).



Low engine coolant level. See **ENGINE COOLANT CHECK** (page 163).



Dynamic Stability Control (DSC). See **PRINCIPLE OF OPERATION** (page 140).



Adaptive front lighting system. See **ADAPTIVE FRONT LIGHTING SYSTEM (AFS)** (page 74).

Warning indicators (information)

The following will illuminate during normal driving to indicate that a particular system or feature is operating.



Seat belt reminder. See **SEAT BELT REMINDER** (page 55).



Door open. See **LOCKING AND UNLOCKING** (page 44).



Low screen washer level. See **WASHER FLUID CHECK** (page 167).



Diesel glow plugs active. See **STARTING A DIESEL ENGINE** (page 115).



Hill Descent Control (HDC) active. See **PRINCIPLE OF OPERATION** (page 136).



Cruise control active. See **USING CRUISE CONTROL** (page 130).



Direction indicator. See **DIRECTION INDICATORS** (page 75).



Trailer direction indicator. See **TOWING A TRAILER** (page 150).



Side lamps on. See **LIGHTING CONTROL** (page 72).



Headlamp high beam on. See **LIGHTING CONTROL** (page 72).



Rear fog lamps on. See **REAR FOG LAMPS** (page 73).



Front fog lamps on. See **FRONT FOG LAMPS** (page 72).

Diesel particulate filter warnings

If either of the messages **DPF FULL** or **DPF FULL VISIT DEALER** are displayed, you must resolve the problem as soon as possible. See **DIESEL PARTICULATE FILTER (DPF)** (page 116).

Quick start

Wipers and washers

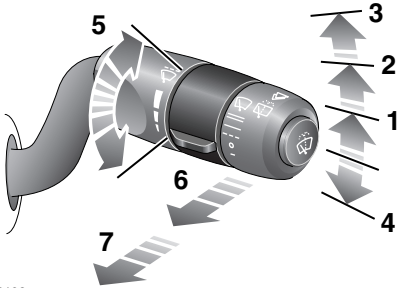

E83198

Windscreen wipers

1. Intermittent wipe/rain sensor
2. Low speed wipe
3. High speed wipe
4. Single wipe - pull down and release to operate
5. Rotate control to adjust speed of intermittent wipe or sensitivity of rain sensor

Windscreen washer



Push the button on the end of the lever to operate the windscreen washer.

Rear wiper and washer

Pull the lever to position **6** for intermittent operation of the rear wiper. Pull and hold the lever in position **7** to operate the rear washer and wiper.

Exterior lighting

Exterior lamps master switch

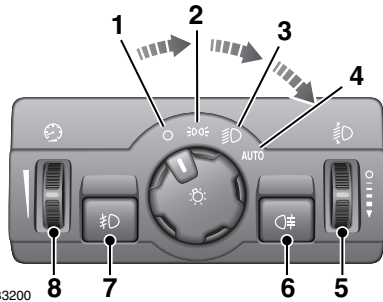

E83200

1. Exterior lamps off
2. Side lamps
3. Headlamps
4. Autolamps
 - With the switch in **AUTO** and the engine running or ignition on, a sensor monitors the exterior light levels and will automatically switch the side lamps and dipped headlamps on and off as required.
5. Headlamp levelling control (Halogen headlamps)
6. Rear fog lamps
7. Front fog lamps
8. Facia illumination dimmer control

Quick start

Direction indicators and headlamp high beam

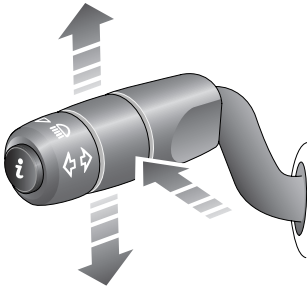

E83199



Move the lever up or down to activate the direction indicators.

Moving the lever up or down against spring pressure and then releasing will flash the indicators three times. Useful for lane changing.



Push the lever away from you to select headlamp high beam. A warning indicator will illuminate on the instrument pack.

To flash the headlamps, pull the lever towards the steering wheel and then release.

Gearshift interlocks

Park

The remote control must be inserted in the docking port, the footbrake applied and the selector release button pressed before the gear selector can be moved from **P** (Park).

Neutral

If the vehicle remains stationary with **N** (Neutral) selected, the selector lever will lock into the **N** position after 3 seconds.

Press the selector release button and apply the footbrake to move the selector lever from **N**.

Automatic transmission

Sports mode

Operating note

If Terrain Response is fitted, Sports mode is only available when the **General** program is selected.

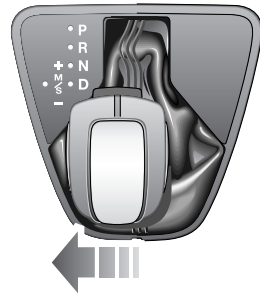

E83201

In Sports mode, automatic gear changing is maintained but the gearshift changes are modified to improve performance.

To select Sports mode, move the gear selector from the **D** position towards the left-hand side of the vehicle.

The word **SPORT** will appear on the instrument pack display and the LED in the gear selector surround will illuminate.

Quick start

CommandShift™

CommandShift gear selection can be used as an alternative to automatic gear selection and is particularly effective when rapid acceleration or engine braking are required.

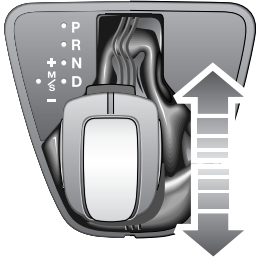

E83202

- Select Sports mode. The transmission will automatically select the gear most appropriate to the vehicle's road speed and accelerator position.
- Moving the selector lever forward (+) or backwards (-) and then releasing will manually select a higher or lower gear (when available). The message **TRANSMISSION COMMANDSHIFT SELECTED** will appear in the message centre.
- Subsequent gear selections will display the selected gear on the instrument pack display.
- To deselect CommandShift mode, move the selector lever back to the **D** position.

Cruise control

Cruise control enables the driver to maintain a constant road speed without using the accelerator pedal.

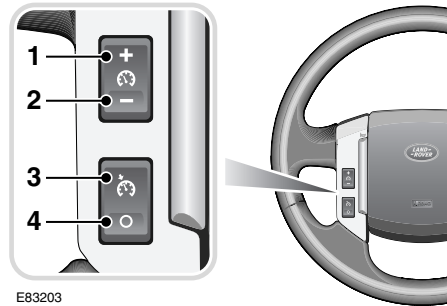

E83203

1. **SET +** : to set a road speed or increase the speed in 2 km/h (1 mph) steps when cruise control is operating.
2. **SET -** : to set a road speed or decrease the speed in 2 km/h (1 mph) steps when cruise control is operating.
3. **RESUME**: resumes the SET speed retained in memory.
4. **CANCEL**: cancels cruise control but retains the set speed in memory.

Operating note

Cruise control will automatically **disengage** when the **brake/clutch pedal** is used or when the vehicle speed falls below 30 km/h (18 mph).

Quick start

Hill Descent Control (HDC)

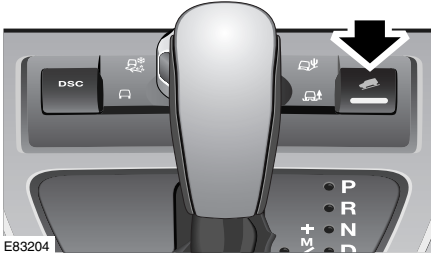
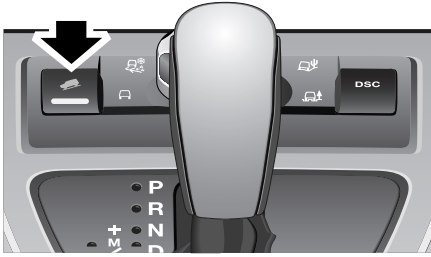

E83204

HDC operates in conjunction with the anti-lock braking system to provide greater control in off-road situations particularly when descending severe gradients.



Press the switch (arrowed in illustration) to select HDC. HDC can be selected at speeds below 80 km/h (50 mph) but will not be fully active until the vehicle speed reduces below 50 km/h (30 mph), confirmed by a continuously illuminated HDC indicator in the instrument pack. Press the switch again to deselect HDC.

Terrain Response system



E83205

The Terrain Response system, if fitted, is always active and cannot be switched off. When the vehicle is started the system will normally start in the **General** program.

Manual selection of a special program, by rotating the knob, will provide benefits in how the vehicle can be driven over different surfaces or terrains by automatically adjusting the vehicle's drive and suspension systems.

It is recommended that a special program be engaged whenever driving conditions could become difficult, and cancelled once the conditions for use are no longer present.

General



Suitable for surfaces that match typical road surfaces.

Grass-Gravel-Snow



Suitable for surfaces which are firm but have a slippery surface, e.g. grass, snow, loose gravel, pebbles, or icy conditions. If the gravel is deep, the Sand program may be more beneficial.

Mud-Ruts



Suitable for soft, muddy, uneven or deeply rutted ground.

Quick start

Sand



Suitable for soft, predominantly dry, yielding sandy ground, e.g. sand dunes and deserts. If the sand is damp or wet the Mud-Ruts program may be more beneficial.

Wading

When wading through water, select the program suitable for the surface beneath the water.

The maximum depth of water should not exceed 500 mm (19.7 inches).

Parking aid

With the ignition on, the front and rear parking sensors are activated whenever reverse gear is selected. A short confirmation tone will sound after one second.

If an obstruction is detected by the sensors, an intermittent tone will sound (higher pitch for objects detected by the front sensors). As the vehicle moves closer to the obstruction the intermittent tone increases in frequency.

When the distance between the sensor and the obstruction is less than approximately 30 cm (1 foot) the tone becomes continuous.

The parking aid is automatically switched off when the vehicle's forward speed exceeds 16 km/h (10 mph).

Front parking aid - manual operation



When driving into a limited space, the front parking aid can be manually activated by pressing the switch on the fascia. The switch will illuminate and a short confirmation tone will sound.

Quick start

Audio system

Standard audio

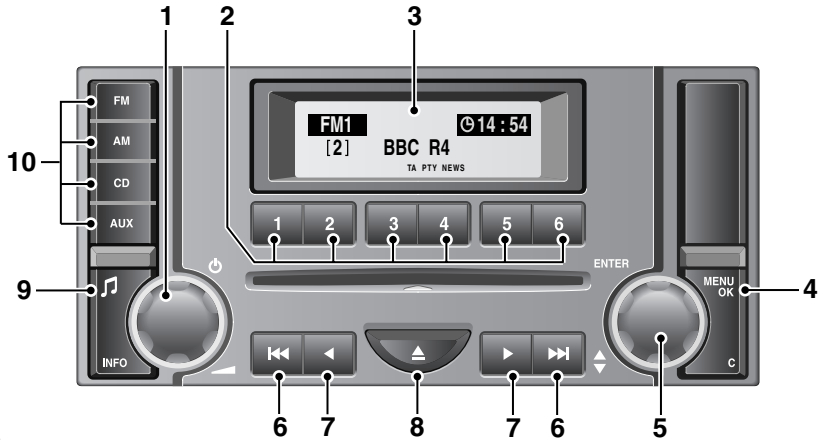

E84421

1. Press to switch audio unit on or off and rotate to adjust the volume.
2. Press appropriate number to select required preset radio station or disc from autochanger.
3. Display screen.
4. Press to access the audio unit menu.
5. Rotate to scroll through menu options or adjust settings. Press to select a menu item or confirm a change.
6. Press to automatically search for a radio station or select a track on a CD.
7. Press to manually search for a radio station or to search in a CD track
8. Press to eject the currently selected CD.
9. Press button repeatedly to scroll through the sound settings options. With the desired sound setting selected, rotate control 1 to adjust. Confirm new setting by pressing button 9.
10. Press the appropriate mode button to select FM, AM, CD or AUX.

Quick start

Premium audio

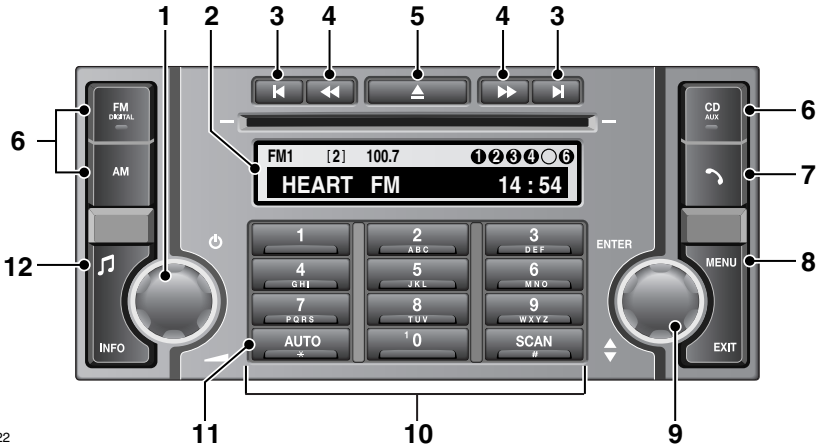

E84422

1. Press to switch audio unit on or off and rotate to adjust the volume.
2. Display screen.
3. Press to automatically search for a radio station or select a track on a CD.
4. Press to manually search for a radio station or to search in a CD track
5. Press to eject the currently selected CD.
6. Press the appropriate mode button to select FM, AM or CD.
 - Press and release the FM button to change between FM1, FM2, DAB1 and DAB2.
 - Press and hold the CD button to change between CD and AUX input.
7. Telephone button.
8. Press to access the audio unit menu.
9. Rotate to scroll through menu options or radio presets. Press to select a menu item or confirm a change.
10. Press appropriate number to select required preset radio station or disc from autochanger.
11. Press and hold to automatically store radio stations. Press and release to access the autostored stations.
12. Press button repeatedly to scroll through the sound settings options. With the desired sound setting selected, rotate control 1 to adjust. Confirm new setting by pressing button 12.

Quick start

Steering wheel controls

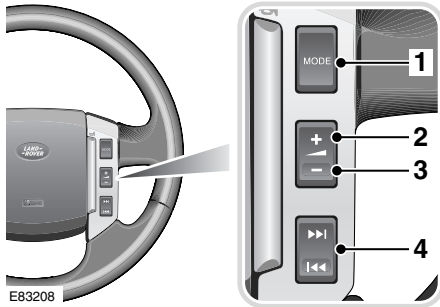

1. Press to switch between Radio, CD, or AUX.
2. Press to increase volume.
3. Press to decrease volume.
4. Press and release to scroll through preset radio stations or CD tracks. Press and hold for two seconds to search up or down for the next radio station/CD track.

Radio operation

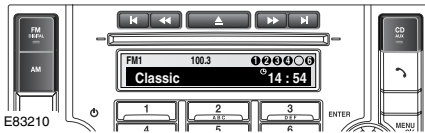

Press either the **FM** or **AM** button to select the required waveband. Repeated presses of either button will scroll through the FM and AM waveband memory options.

Storing radio stations

To automatically store radio stations, press and hold either the **FM** or **AM** button on standard audio units or the **AUTO** button on premium audio units. The stations will be stored under the preset numbers in the selected waveband.

To recall a preset station, press and release one of the numbered preset buttons.

A selection of radio presets can be stored manually. See **STATION PRESET BUTTONS** (page 226).

DAB radio



E88130

On the premium audio unit, press and release the **FM** button repeatedly until either **DAB1** or **DAB2** is displayed. To automatically tune all the available digital radio channels, press and hold the **AUTO** button.

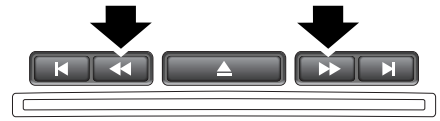

E85661

Use the channel search buttons to scroll through the list of available channels. When you find a channel you want to store, press and hold a numbered preset button.

Quick start



E88124

Some channels can contain subchannels. If subchannels are available, an arrow icon is displayed. To access a subchannel, press and hold one of the channel search buttons. Press and release the channel search button repeatedly to scroll through the available subchannels. See **CHANNEL OPTIONS** (page 236).

CD OPERATION

Compatible disc types

The use of discs with paper labels or double-sided dual format discs (CD/DVD) should be avoided as they could become jammed.

Depending on specification, your audio unit will feature either a single-slot CD player or an integral 6-disc autochanger.

Single CD player

Insert a disc, label side up, into the player. The disc will load and start to play.

To end CD playback, briefly press one of the other mode buttons (FM or AM). Playback will resume when the CD button is pressed again.

To eject the disc, press the eject button. When prompted, remove the disc from the CD slot.

CD autochanger

Loading CDs

To insert a single disc, press the **CD** button then one of the number buttons (**1** to **6**). When prompted by the information display, insert the disc, label side up. The autochanger will load the CD in the selected position.

Playing CDs

When in CD mode, press the appropriate CD number (**1** to **6**) to start playing the selected disc. Playback commences and progresses sequentially through all of the loaded discs.

Playback can be paused by briefly pressing one of the other mode buttons (**FM** or **AM**).

Playback will resume when the **CD** button is pressed again.

Ejecting CDs

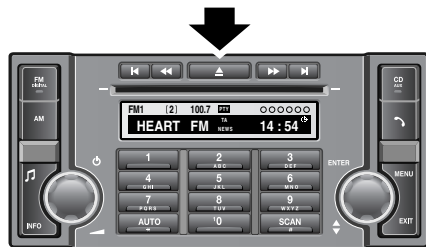

E83211

To eject a single disc, select the required disc by pressing one of the number buttons **1** to **6** and then press the eject button.

To eject all loaded discs, press and hold the eject button, the discs will be ejected one at a time. Remove disc only when the display shows the message **Remove Disc**.

Quick start

Clock setting

Standard audio

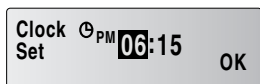

E84423

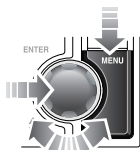

Premium audio

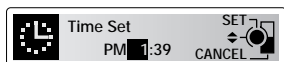

E84424

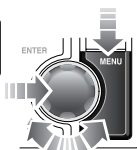

1. Switch on the audio system, by pressing the volume rotary control.
2. Press the MENU button to access the function menu.
3. Rotate the control to select Clock and press to confirm selection.
4. On standard audio units, rotate the control to select Set and press to confirm selection.
5. Rotate the control to adjust the hour and minutes. Press the control to confirm setting after each action. On premium audio units, the time mode (12 or 24 hr) can also be set from this menu.
6. Once the time has been set, on standard audio units, OK will be highlighted. Press the rotary control to accept the settings. Press the EXIT button on premium audio units to cancel and return to the menu.

Telephone - Bluetooth system

Mobile phones with Bluetooth capability can communicate with the vehicle's inbuilt telephone feature. You must pair your Bluetooth mobile phone with the vehicle's system before use.

Mobile phone compatibility

Not all phones are fully compatible with the Land Rover system. For the latest list of compatible phones and software versions, please refer to

www.ownerinfo.landrover.com.

Alternatively consult your Land Rover Dealer/Authorised Repairer.

Pairing a phone to the vehicle's system

1. With the ignition on, press the telephone mode button on the audio unit.
2. When prompted, press the **ENTER** control to confirm that you want to pair a telephone to the system.
3. The system will ask you to check that your Bluetooth function on your telephone is enabled. Press the **ENTER** control to confirm. The system will then search for your telephone.
4. After the search is completed, the detected telephones will be listed. Rotate the **ENTER** control to scroll through the list and press to select the correct telephone.
5. The audio unit will then display a Bluetooth access code number. Enter this number into your telephone. The telephone will now pair to the system.
6. If the pairing fails, a message will appear on the audio unit display. Press the **ENTER** control to retry or press the **EXIT** button and restart the process.
7. To cancel the pairing process, press and hold the telephone button on the audio unit.

Quick start

Operating note

If more than one paired Bluetooth phone is in range, the system will automatically select the last phone used in Bluetooth mode.

Making a call



1. With a paired handset, press the telephone mode button on the audio unit.
2. Enter the required telephone number using the numeric keypad.
3. Press and release the **ENTER** control or operate the answer call switch **1** on the steering wheel to send.

Receiving a call

To answer an incoming call, press and release the **ENTER** control on the audio unit, or operate the answer call switch **1** on the steering wheel controls.

To end, or reject an incoming call, press and release the **EXIT** button or operate the end call switch **2** on the steering wheel controls.

Filling station information

FILLING STATION INFORMATION

Fuel filler flap

Fuel filler flap location



A small arrow on the fuel gauge indicates which side of the vehicle the fuel filler flap is located.

Fuel filler flap opening



E83217

With the vehicle unlocked, pull the flap (as arrowed in the illustration) to open.

Operating note

The fuel filler flap will not open if the vehicle is locked.

Refuelling

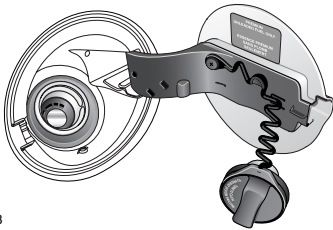

E83218

The filler cap is secured to the vehicle by a strap. For your convenience, a holder is provided, on the fuel filler flap, to hook the strap over while refuelling.

After refuelling, tighten the filler cap until it clicks three times.

Fuel tank capacity

Model	Litres	Gallons
Petrol engine	70	15.4
Diesel engine	68	14.9

Fuel specification

CAUTIONS

- ⚠ Land Rover petrol engines are not fitted with equipment necessary for use of fuels containing more than 10 percent ethanol.
- ⚠ Do not use E85 fuels (85 percent ethanol content). If E85 fuels are used, serious engine and fuel system damage will occur.

The correct fuel specification for your vehicle is shown on the inside of the fuel filler flap. See **TECHNICAL SPECIFICATIONS** (page 146).

Incorrect fuelling

CAUTION

- ⚠ If the fuel tank is accidentally filled with the wrong type of fuel, it is essential that the engine is not started and you seek qualified assistance.

Filling station information

Tyre pressures

Tyre pressure label

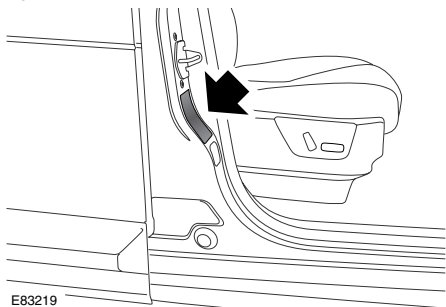

E83219

The correct tyre pressures are shown on a label attached to the driver's door pillar.

Engine oil specification

Model	Specification
Petrol engine	Use only 0W-30 engine oil, meeting ACEA A5 or B5 specification.
Diesel engine	Use only 5W-30 oil meeting Ford 913-B specification.

LAND ROVER RECOMMENDS



Engine coolant specification

Top-up to the upper level indicator mark. Use only a 50% mix of water and Texaco XLC antifreeze. See **ENGINE COOLANT CHECK** (page 163).

Introduction

SYMBOLS GLOSSARY

Warnings

WARNING



Safety warnings are included in this handbook. These indicate either a procedure which must be followed precisely, or information that should be considered with great care in order to avoid the possibility of personal injury.

Cautions

CAUTION



Cautions are included in this handbook. These indicate either a procedure which must be followed precisely, or information that should be considered with great care in order to avoid the possibility of damage to your vehicle.

Symbols



This recycling symbol identifies those items that must be disposed of safely in order to prevent unnecessary damage to the environment.



This symbol identifies those features that can be adjusted, disabled or enabled by a Land Rover Dealer/Authorised Repairer.

LABEL LOCATIONS



Warning labels attached to your vehicle bearing this symbol mean: Do not touch or adjust components until you have read the relevant instructions in the handbook.



Labels showing this symbol indicate that the ignition system utilises very high voltages. Do not touch any ignition components while the starter switch is turned on.

Warning labels

Labels are attached to your vehicle at several positions. These are applied to draw your attention to important subjects, e.g. tyre pressures, tow bar use, airbags, roll-over risk, engine compartment hazards, etc.

Additional information labels may also be found at these locations.

Introduction

It is important that you are familiar with these subjects to ensure that your vehicle and its features are used safely. Using the index at the back of this handbook, refer to the relevant topic for more information.

HEALTH AND SAFETY

WARNINGS



Your vehicle has a higher ground clearance and hence, a higher centre of gravity than ordinary passenger cars, to enable the vehicle to perform in a wide variety of off-road applications. An advantage of the higher ground clearance is a better view of the road allowing you to anticipate problems.



The vehicle is not designed for cornering at the same speed as conventional passenger cars any more than a low-slung sports car is designed to perform satisfactorily under off-road conditions. If at all possible, avoid sharp turns or abrupt manoeuvres. As with other vehicles of this type, failure to operate the vehicle correctly may result in loss of control or vehicle roll-over.



The vehicle should not be parked over long dry grass or other combustible material, particularly during dry weather. As the heat generated by the exhaust and emission control systems may be sufficient to start a fire.



Before exiting the vehicle ensure that **P** park is selected and the park brake applied. When exiting the vehicle ensure that the remote control is removed from the vehicle.

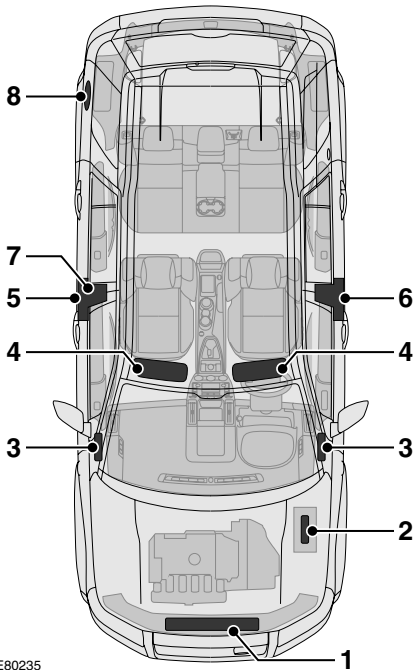

E80235

1. Bonnet locking platform - Air conditioning label
2. Top face of battery - Battery warning symbols
3. End of fascia (passenger side) - Passenger airbag label
4. Sun visor - Airbag label, Vehicle handling label
5. Base of right-hand B pillar - Tyre pressure label, Airbag warning label
6. Left-hand B pillar - Airbag warning label, Vehicle Identification Number label
7. Right-hand B pillar - Vehicle Identification Number label (China)
8. Inner face of fuel filler flap - Fuel specification label

Introduction

DATA RECORDING

Service data recording

Service data recorders in your vehicle are capable of collecting and storing diagnostic information about your vehicle. This potentially includes information about the performance or status of various systems and modules in the vehicle such as engine, throttle, steering or brakes.

In order to properly diagnose and service your vehicle, Land Rover and service and repair facilities may access vehicle diagnostic information through a direct connection to your vehicle.

Event data recording

Event data recorders are capable of collecting and storing data during a crash or near-crash event. The recorded information may assist in the investigation of such an event. The modules may record information about both the vehicle and the occupants, potentially including information such as:

- How various systems in your vehicle were operating.
- Whether or not the driver and passenger seat belts were buckled.
- How far, if at all, the driver was depressing the accelerator and/or the brake pedal.
- How fast the vehicle was travelling.
- Where the driver was positioning the steering wheel.

To access this information special equipment must be connected directly to the recording modules. Land Rover do not access event data recorder information without obtaining consent, unless pursuant to court order or where required by law enforcement, other government authorities or third parties acting with lawful authority.

Other parties may seek to access the information independently of Land Rover.

DISABILITY MODIFICATIONS

Occupants with disabilities which may require modification of the vehicle must contact a Land Rover Dealer/Authorised Repairer before any modifications are made.

PARTS AND ACCESSORIES

WARNINGS



The fitting of non-approved parts and accessories, or the carrying out of non-approved alterations or conversions, may be dangerous and could affect the safety of the vehicle and occupants and also invalidate the terms and conditions of the vehicle warranty.



Land Rover will not accept any liability for death, personal injury or damage to property which may occur as a direct result of fitment of non-approved accessories or the carrying out of non-approved conversions to Land Rover vehicles.



Land Rover strongly advise against making any modifications to the suspension or steering system. This could seriously affect the handling and stability of the vehicle leading to loss of control or roll-over.

Introduction

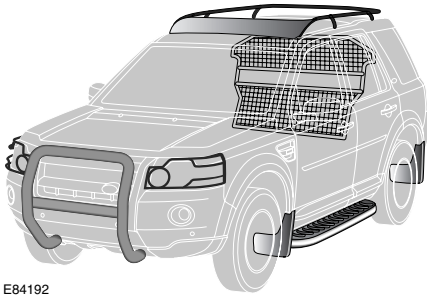

E84192

The vehicle has been designed, built and tested to cope with a variety of off-road driving conditions, some of which can place the severest possible demands on control systems and components. As such, fitting replacement parts and accessories that have been developed and tested to the same stringent standards as the original components will safeguard the continued reliability, safety and performance of your vehicle.

To augment the vehicle's already impressive performance, a comprehensive range of Land Rover approved spare parts and accessories is available, enabling the vehicle to fulfil a wide variety of roles, and enhancing and protecting the vehicle in the many tasks to which it can be applied.

Land Rover parts are the only parts built to original equipment specifications and approved by Land Rover designers; this means that every single part and accessory has been rigorously tested by the same engineering team that designed and built the vehicle and can therefore be guaranteed for twelve months with unlimited mileage.

A full list and description of all accessories is available from your Land Rover Dealer/ Authorised Repairer.

Electrical equipment

WARNING



It is extremely hazardous to fit or replace parts or accessories, the installation of which requires the dismantling of, or addition to, either the electrical or fuel systems.

Always consult a Land Rover Dealer/ Authorised Repairer before fitting any accessory.

Fitting inferior quality parts or accessories, may be dangerous and could invalidate the vehicle warranty.

It is recommended that you always consult a Land Rover Dealer/Authorised Repairer for advice regarding the approval, suitability, installation and use of any parts or accessories before fitting.

Introduction

Airbag system

WARNING



The components that make up the airbag system are sensitive to electrical or physical interference, either of which could easily damage the system and cause inadvertent operation or a malfunction of the airbag module.

To prevent malfunction of the airbag system always consult a Land Rover Dealer/ Authorised Repairer before fitting any of the following:

- Electronic equipment such as a mobile phone, two-way radio or in-car entertainment system.
- Accessories attached to the front of the vehicle.
- Any modification to the front of the vehicle.
- Any modification involving the removal or repair of any wiring or component in the vicinity of any of the airbag system components, including the steering wheel, steering column, instrument or fascia panels.
- Any modification to the fascia panels or steering wheel.

After-sales service

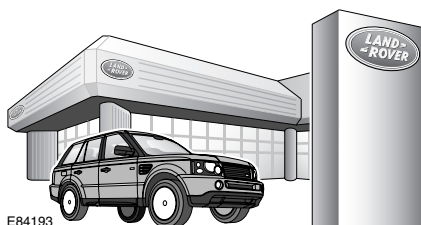

The After Sales Parts service is of paramount importance, both in the UK and across the world. In the UK there are over 100 authorised Land Rover Dealers/Authorised Repairers, all computer linked for rapid ordering of parts and accessories.

In addition, with franchised representation in over 100 countries worldwide, Land Rover are able to support your vehicle wherever you go.

Travelling abroad

In certain countries, it is a legal requirement to fit parts made to the vehicle manufacturers' specification.

Owners should ensure that any parts or accessories fitted to the vehicle while travelling abroad will also conform to the legal requirements of their own country when they return home.

Keys and remote controls

USING THE KEY

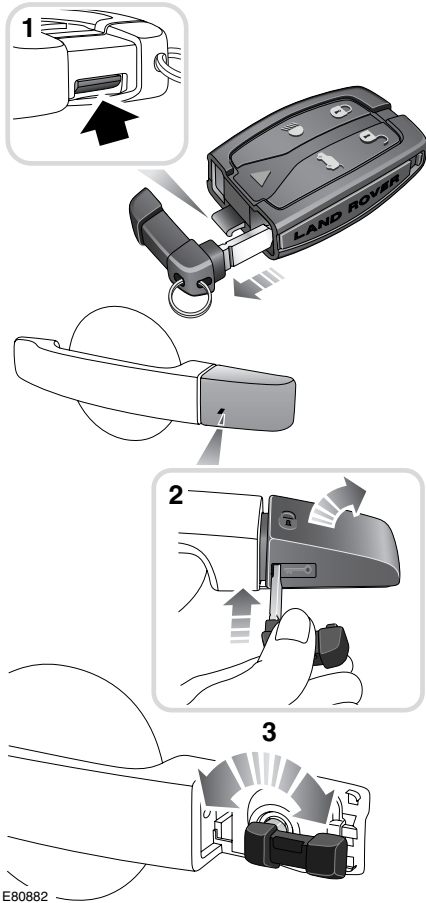

1. Press the release tab and pull out the key blade.
2. Use the key blade to remove the door lock cover.
3. Insert the key into the lock and rotate to unlock.

Note: When the door is opened the alarm will begin to sound. To silence the alarm, insert the remote into the start control unit.

GENERAL INFORMATION ON RADIO FREQUENCIES

Note: The radio frequency used by your remote control may be used by other devices. For example: amateur radios, medical equipment, wireless headphones, or other remote control devices. This may cause the frequency to be jammed, and prevent your remote control from operating correctly.

Environmental conditions can affect the operation of remote controls and the operating range may vary considerably depending on the vehicle's location.

Keys and remote controls

USING THE REMOTE CONTROL

Remote control

WARNING



Never leave the remote control in the vehicle if children or animals are also left in the vehicle. The vehicle's systems and remote control functions could be operated, which may result in injury.

Note: The operational range of the remote control will vary considerably depending on atmospheric conditions and interference from other transmitting devices.

The vehicle is supplied with two remote controls, but up to six can be programmed to the vehicle at any one time.

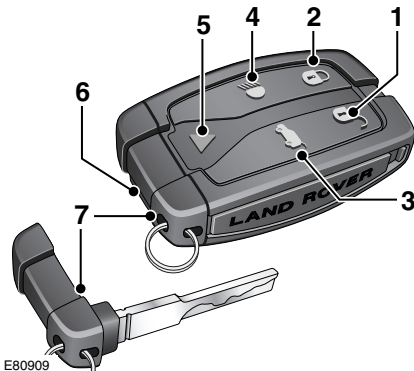

1. Unlock.
2. Lock.
3. Tailgate release.
4. Approach lighting.
5. Emergency alarm.
6. Key blade release tab.
7. Key blade.

Unlocking



Press briefly to unlock the vehicle, and deactivate the alarm. The hazard warning lamps will flash twice to indicate that the vehicle is unlocked and the alarm has been deactivated. The interior lamps will illuminate to assist entry to the vehicle.

Note: The fuel filler flap can only be opened when the vehicle is unlocked.

Single/Multi-point entry

When you press the unlock button your vehicle will unlock in one of two ways:

1. Unlock the driver's door, fuel filler flap, and tailgate only. A second press is required to unlock the remaining doors.
2. Unlock all doors, fuel filler flap, and the tailgate.

This security feature unlocks only the driver's door and tailgate. It can be disabled on individual remote controls by unlocking the vehicle then simultaneously pressing and holding the lock and unlock buttons for three seconds. The vehicle will lock and then unlock in the currently selected mode and the hazard warning lights will flash twice to confirm the change. You can now unlock all doors with a single press. Repeating the procedure will re-enable Single point entry.

Global opening

Press and hold the unlock button for three seconds to unlock the vehicle and open all of the windows.

Keys and remote controls

Single and double locking

The vehicle can be locked in two ways.

Single locking

Single locking secures the vehicle and prevents the doors being opened from outside of the vehicle. The doors can be unlocked and opened from inside the vehicle.

Double locking

WARNING



Never double lock the vehicle with people, children, or pets inside. In the event of an emergency they would be unable to escape, and the emergency services would be unable to release them quickly.

Double locking secures the vehicle and prevents the doors being opened from inside or outside of the vehicle. The doors can not be unlocked or opened from inside the vehicle.

This provides additional security if the vehicle is left unattended. The vehicle cannot be opened by breaking a window and operating the door locks from inside the vehicle.

Locking



Press briefly to single lock the vehicle, and partially activate the alarm. The hazard warning lamps will flash to indicate that the vehicle is locked. A second press within three seconds will double lock the vehicle and fully arm the alarm. The hazard warning lamps will flash again to indicate the enhanced lock/alarm state.

Note: *The fuel filler flap can only be opened when the vehicle is unlocked.*

Global closing

WARNING



Ensure that no children, pets, or obstructions are in any open aperture before operating global closing. Safety mechanisms are in place to prevent serious injury, however, injuries can still occur.

Press and hold the lock button for three seconds to single lock the vehicle, fully arm the alarm, and close all of the windows.

Note: *For safety reasons, the sunroof does not close automatically. It should be closed in the normal way before exiting the vehicle.*

Automatic relocking

If a door, or the tailgate, are not opened within one minute of unlocking the vehicle, doors will lock again automatically.

Approach lighting



When approaching the vehicle during darkness press to switch on the approach illumination. Press again to turn the approach lamps off.



The approach illumination period set at the factory is thirty seconds. This can be configured by a Land Rover Dealer/Authorised Repairer to provide illumination lasting between Zero and 120 seconds.

Keys and remote controls

Tailgate



Press briefly to release the tailgate.

Emergency alarm



Press and hold for three seconds, or press twice within three seconds, to activate the horn and the hazard

lamps.

Once active for more than five seconds the alarm can be cancelled by pressing the button and holding for three seconds, or pressing twice within three seconds.

Note: *The horn and hazard lamps will switch off automatically after two minutes and forty five seconds.*

Remote battery

The remote control batteries are recharged when the remote is docked and the engine is running. For this reason it is recommended that each remote is used periodically. This will ensure that the batteries are kept charged and ready for use.

Locks

LOCKING AND UNLOCKING

WARNING



Never double lock the vehicle with people, children or pets inside. In the event of an emergency they would be unable to escape, and the emergency services would be unable to release them quickly.

Drive-away locking



The vehicle can be configured by a Land Rover Dealer/Authorised Repairer to lock automatically

when in motion. Contact your Dealer/Authorised Repairer for further information.

Locking and unlocking from inside the vehicle

Door buttons and levers

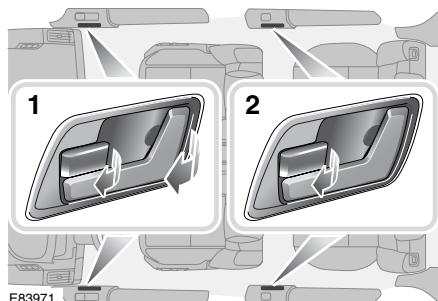

1. The front doors can be unlocked using the door buttons, or unlocked and opened using the lever.
2. The rear doors are unlocked using the door buttons. If the doors are locked, operating the lever will have no effect.

Note: For information on operating the child safety locks. See **CHILD SAFETY LOCKS** (page 69).

Facia buttons

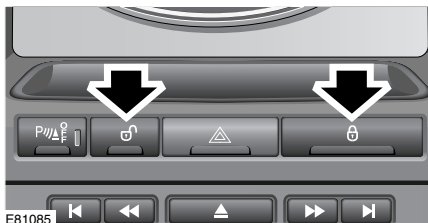

To lock or unlock the vehicle press the respective button on the facia. This will lock, or unlock, all doors and the tailgate.

Note: Pressing and holding both buttons simultaneously for three seconds will release the tailgate.

Mis-lock

If one of the doors, the bonnet, or the tailgate are not shut fully the horn will emit a single tone. The vehicle will not fully lock until the door, bonnet, and tailgate are fully closed.

Alarm

ARMING THE ALARM



The engine is automatically immobilised when the remote control is removed from the starter control unit. The alarm system is automatically armed when the remote lock button is pressed. The hazard lamps will flash to indicate that the alarm is armed.

Full alarm

To set full alarm protection ensure that all the windows and the sunroof are closed. Then press the lock button twice within three seconds. The hazard warning lights will flash twice to confirm the alarm state.

Once fully armed the alarm will sound if :-

- the bonnet, tailgate, or a door are opened.
- movement is detected within the vehicle interior.
- a window, front or rear windscreen, or sunroof glass are broken.
- the vehicle is raised or tilted.
- the vehicle battery is disconnected.
- an attempt is made to disconnect the alarm siren.

Note: If the alarm is armed and a window or the sunroof are left open the alarm will sound due to movement of air currents.

Partial alarm

To set partial alarm protection, briefly press the lock button once. The hazard warning lights will flash once to confirm the alarm state.

Once partially armed the alarm will sound if :-

- the bonnet, tailgate, or a door are opened.
- the vehicle battery is disconnected.
- an attempt is made to disconnect the alarm siren.

Note: This setting should be used in circumstances such as travelling on a ferry, when pets are to be left in the vehicle, when a window must be left open etc

Alarm indicator



E81141

The alarm status is displayed by the indicator.

- Indicator off - alarm disarmed.
- Indicator flashes once per second - alarm is armed and engine immobilised.
- Indicator flashes rapidly - the alarm has been triggered.

Note: The alarm status indicator will flash rapidly when the alarm has been disarmed, but the remote has not been docked.

Alarm

DISARMING THE ALARM



When the vehicle is unlocked using the remote control, the alarm is automatically disabled. The hazard lamps will flash twice to indicate that the alarm is disabled.

Disarming when the unlock button fails to work

If, when pressed, the unlock button fails to operate the vehicle can still be unlocked and the alarm disabled. To unlock the vehicle :-

1. Unlock the drivers door using the key blade.
2. Dock the remote control.

Note: *When the drivers door is unlocked using the key, the alarm will sound until the remote is docked.*

Deactivating the alarm when triggered

If the alarm has been triggered it can be deactivated by pressing the remote unlock button, or by docking the remote control.

Seats

SITTING IN THE CORRECT POSITION

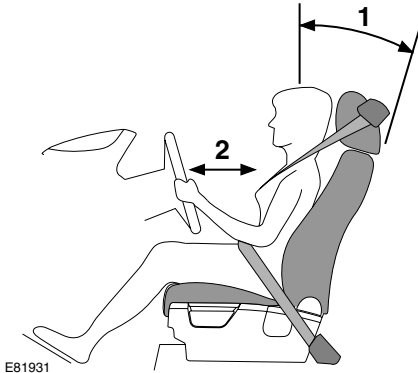

- Position the seatbelt so that it is mid-way between your neck and your shoulder. Fit the strap tightly across your hips, not across your stomach.
- Ensure that your driving position is comfortable, and enables you to maintain full control of the vehicle.

WARNING



Do not adjust the seat while the vehicle is moving. Doing so could cause loss of vehicle control and personal injury.

The seat, head restraint, seat belt and airbags, all contribute to the protection of the user. Correct use of these components will give you greater protection, therefore you should observe the following points:

1. Sit in an upright position with the base of your spine as far back as possible and the seatback reclined no more than 30 degrees.
 2. Do not move the driver's seat too close to the steering wheel. Ideally, a minimum distance of 254 mm (10 inches) is recommended between the breastbone and the steering wheel airbag cover. Hold the steering wheel in the correct position with your arms slightly bent.
- Adjust the head restraint so that it's highest point is level with the top of your head.

Seats

MANUAL SEATS

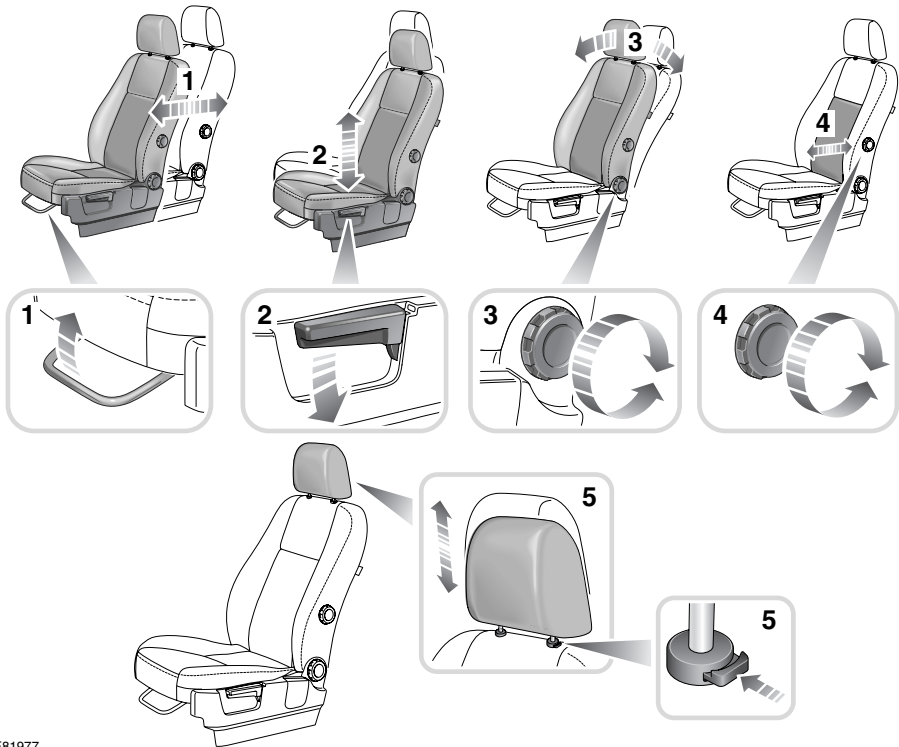

E81977

1. Fore and aft adjustment.
2. Height adjustment.
3. Seat back angle adjustment.
4. Lumbar support adjustment.
5. Head restraint height adjustment.

Seats

ELECTRIC SEATS

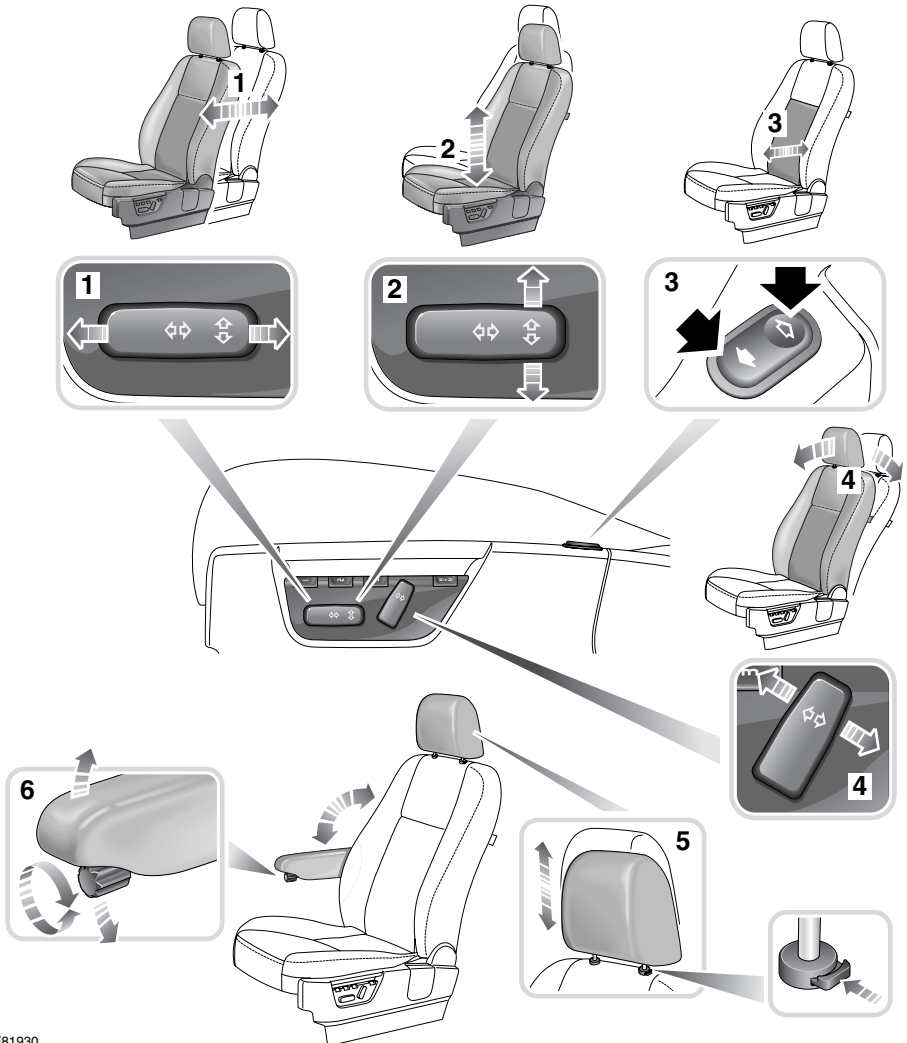

E81930

1. Fore and aft adjustment.
2. Height adjustment.
3. Lumbar support adjustment.
4. Seat back angle adjustment.
5. Head restraint height adjustment.
6. Armrest height adjustment.

Seats

To adjust the seats, the remote control must be inserted in the starter control unit and the ignition on. On those vehicles equipped with the memory driver's seat, the seat has a 10 minute active period, initiated when the driver's door is opened/closed or the remote control is removed from the starter control unit.

Driving position memory

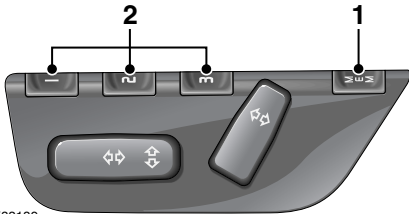

E83189

Once you have adjusted the power operated driver's seat and exterior mirrors for your ideal driving position, the vehicle can memorise these settings for future use.

1. Press the memory store button to activate the memory function.
2. Press one of the preset buttons within five seconds to memorise the current settings. **MEMORY STORED** will be displayed on the message centre accompanied by an audible chime to confirm the settings have been memorised.

A seat position will only be memorised during the five second active period.

Any existing settings will be over-written when programming a memory position.

Seats

HEAD RESTRAINTS

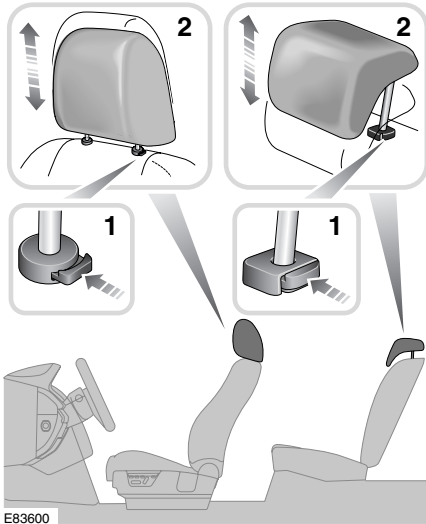

WARNINGS

 Head restraints are designed to support the head, not the back of the neck. The restraint must be positioned correctly to restrain rearward movement of the head in a collision. An incorrectly adjusted head restraint increases the risk of death or serious injury in the event of a collision.

 Adjust the head restraint so that the top of the head restraint is above the centre line of the head. An incorrectly adjusted head restraint increases the risk of death or serious injury in the event of a collision. See **SITTING IN THE CORRECT POSITION** (page 47).

 Do not drive, or carry passengers with the head restraints removed from occupied seats. The absence of a correctly adjusted head restraint increases the risk of death or serious injury in the event of a collision.

WARNINGS

 Never adjust the head restraints while the vehicle is in motion. An incorrectly adjusted head restraint increases the risk of death or serious injury in the event of a collision.

1. Press the locking collar to release the head restraint.
2. Whilst pressing the locking collar, move the head restraint up or down to the required position.

REAR SEATS

WARNINGS

 Always ensure that objects carried within the vehicle are secured properly. Unsecured items can cause death or serious injury in the event of an impact or sudden manoeuvre.

 Never allow passengers to travel in the load space under any circumstances. All vehicle occupants should be seated correctly, and wear a seat belt at all times when the vehicle is in motion. Failure to do so will greatly increase the risk of death and serious injury in the event of an accident or heavy braking.

The split fold rear seat can be folded completely to accommodate large loads, or partially to accommodate large loads, and still retain seating for passengers.

Seats

Folding the rear seats

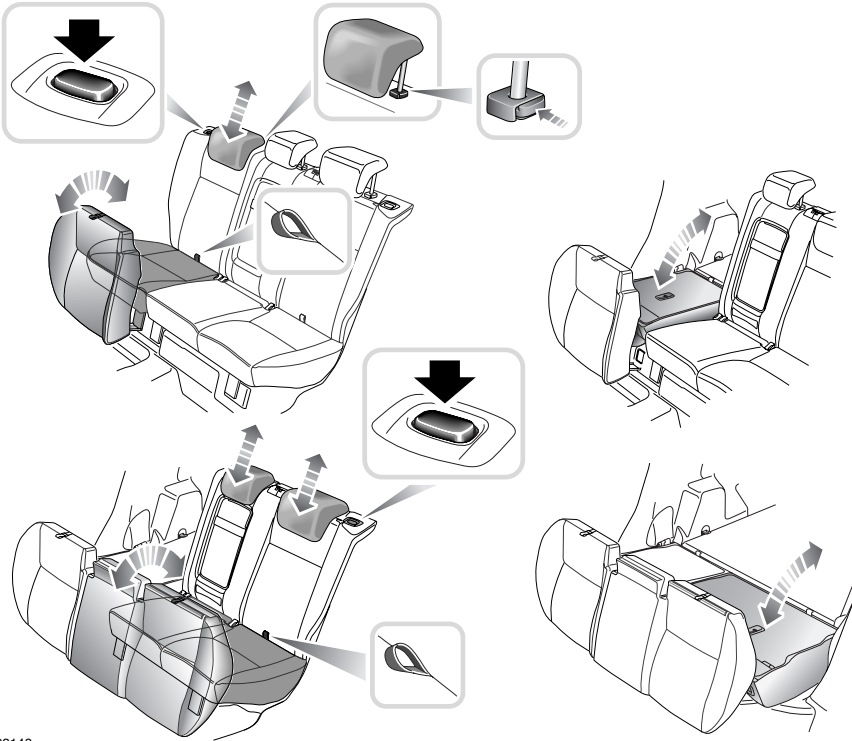

E83148

1. Using the loop provided at the back of the seat base, pull the back of the seat base up and forward.
2. Fully lower the head restraints.
3. Press the seat back release button, and fold the seat back fully forward.
4. If required, repeat the process for the second seat section.

Note: To achieve a completely flat load floor it will be necessary to completely remove the rear head restraints.

WARNING



Ensure that if the rear head rests are removed they are stored securely. Never leave them loose in the vehicle, as they can cause serious injury or death in the event of an accident, heavy braking, or sudden manoeuvres.

Seats

Raising the rear seats

The process for raising the rear seat is the reverse of folding.

WARNING



Ensure that when the seat back is raised the locking mechanism is fully engaged. Failure to do so can increase the risk of death or serious injury in the event of an accident or sudden manoeuvre or heavy braking.

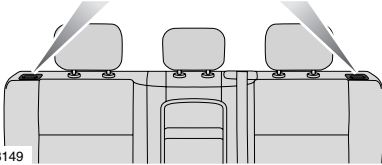
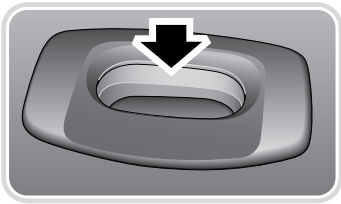

When the seat back has been raised fully, and is locked into position, the release button will pop-up.

Note: The red warning section will only be visible if the seat back has not been locked into position.

HEATED SEATS



Note: To prevent the battery from becoming discharged the seat heaters will only operate when the engine is running.

The seat heaters will maintain a factory set temperature, and have two levels of operation, high, and low. There are two indicators in each switch, if both are on the setting is high, if only one is on the setting is low.

To operate:-

1. Press once to turn on to high.
2. Press again to change the setting to low.
3. Press a third time to switch off.

Seat belts

PRINCIPLE OF OPERATION

Seat belts

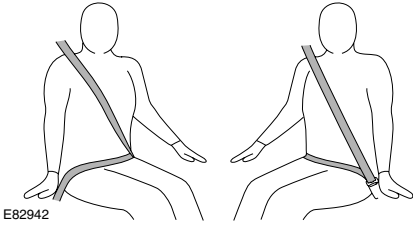



WARNINGS

 Seat belts are designed to bear upon the bony structure of the body, and should be worn low across the front of the pelvis, or the pelvis chest and shoulders, as applicable; wearing the lap section of the belt across the abdominal area must be avoided.

 Seat belts should be adjusted as firmly as possible, consistent with comfort, to provide the protection for which they have been designed. A slack belt will greatly reduce the protection afforded to the wearer.

 Care should be taken to avoid contamination of the webbing with polishes, oils and chemicals, and particularly battery acid. Cleaning may safely be carried out using mild soap and water.

 The belt should be replaced if webbing becomes frayed, contaminated or damaged.

 It is essential to replace the entire assembly after it has been worn in a severe impact even if damage to the assembly is not obvious.

 Belts should not be worn with the straps twisted.

WARNINGS

 Do not carry hard, fragile, or sharp items between your person and the seat belt. In an impact the pressure from the seat belt on such items can cause them to break, which in turn may cause death or serious injuries.

 Each belt assembly must only be used by one occupant; it is dangerous to put a belt around a child being carried on the occupant's lap.

 The occupants of the front seats should not travel with the seat back at more than 30 degrees from upright. Doing so will reduce the protection afforded by the seat belt.

Seat belt safety

WARNINGS

 Seat belts should be worn by all vehicle occupants, for every journey no matter how short. Failure to do so will greatly increase the risk of death or serious injury in the event of an accident.

 No modifications or additions should be made which prevent the seat belt mechanism from taking up slack, or prevent the seat belt being adjusted to remove slack. A slack seat belt offers a greatly reduced level of occupant protection in an impact.

 If any damage, wear, cuts, defects, or impaired operation are noted with the seat belts, the vehicle should be taken to a Land Rover Dealer/Authorised repairer for immediate attention. Do not use the vehicle if the seat belts cannot be operated correctly.

 When using seat belts to restrain items other than occupants, take care to ensure that the belts are not damaged, or exposed to sharp edges.

Seat belts

WARNINGS



Care must be taken to avoid contaminating the seat belt webbing, and seat belt mechanisms with any chemicals, liquids, grit, dirt, or cleaning products. If the seat belts do become contaminated they should be replaced immediately. Contaminated seat belts may not operate correctly in an impact and cannot be relied upon.

Seat belt checks

Note: *If the vehicle is parked on an incline, the seat belt mechanism may lock. This is not a fault, and the belt should be gently eased out from the upper anchorage.*

The seat belts should be inspected regularly to check for fraying, cuts, or wear to the webbing, and the condition and security of the mechanism, buckles, adjusters, and mounting points.

Checks

- With the seat belt fastened, give the webbing near the buckle a quick upward pull. The buckle must remain securely locked.
- With the seat belt unfastened, unreel the seat belt to the limit of its travel. Check that it unreels smoothly with no snatches or snags. Allow the belt to fully retract, again checking for smooth operation.
- Partially unreel the seat belt, then hold the tongue plate and give a quick forward pull. The mechanism must lock and prevent any further unreeling.

If any of the seat belts fail to meet those criteria, immediately contact your Land Rover Dealer/Authorised Repairer.

SEAT BELT REMINDER



If the driver's seat belt is not fastened when the vehicle is in motion, a chime will be heard and the seat belt warning indicator will illuminate. The warning chime and indicator will also be activated if the front passenger seat is occupied without the seat belt being fastened.

Note: *Objects placed on the front passenger seat may activate the seat belt reminder warning chime and indicator. It is recommended that any objects placed on the front passenger seat are secured using the seat belt.*

Seat belts

FASTENING THE SEAT BELTS

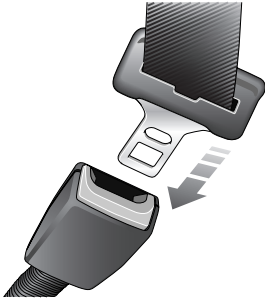

E82905

1. Draw the belt out smoothly, ensure that the belt height, the seat, and your position on the seat are correct. The belt should lay flat across the pelvis, chest, and mid-point of the collar bone between the neck and shoulder.
2. With the seat belt correctly positioned, place the metal tongue into the buckle nearest to you. Press it in until a click is heard.

Releasing the seat belts

Note: When releasing the seat belt it is advisable to hold the belt before pressing the release button. This will prevent the belt from retracting too quickly.

To release the seat belt, press the red button.

SEAT BELT HEIGHT ADJUSTMENT

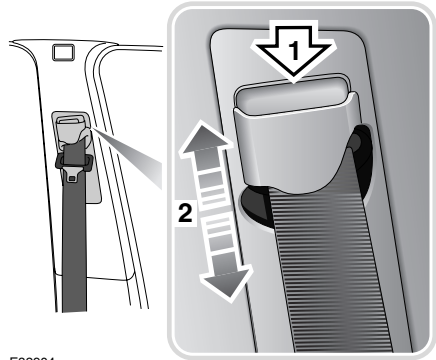

E82904

WARNING



Correct seat belt adjustment is essential for safety and comfort. Ensure that the height is correctly adjusted and the mechanism is locked in place before driving the vehicle. Do not attempt to adjust the seat belt height once the vehicle is in motion. Doing so may cause you to lose control of the vehicle, or incorrectly adjust the seat belt.

1. Press to release the catch.
2. With the catch depressed move the mechanism slide up or down to the required height. Ensure that the locking mechanism has engaged.

When correctly positioned the seat belt should cross the collar bone at the mid-point between the neck and end of your shoulder.

Where possible, rear seat passengers should adjust their seating position to achieve the same seat belt position.

Seat belts

USING SEAT BELTS DURING PREGNANCY

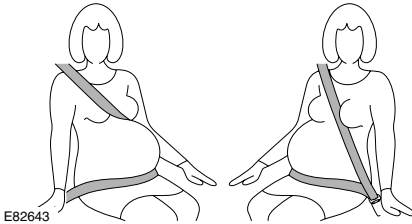

WARNINGS



Position the seat belt correctly for the safety of the mother and unborn child.

Never wear just the lap strap, and never sit on the lap strap whilst using just the shoulder strap. Both of these actions are extremely dangerous, and may increase your risk of serious injury in the event of an accident or during emergency braking.



Never place anything between you and the seat belt in an attempt to cushion the impact in the event of an accident.

It can be dangerous, and will reduce the effectiveness of the seat belt in preventing injury.

Position the lap strap comfortably across the hips beneath the abdomen. Place the diagonal part of the seat belt between the breasts and to the side of the abdomen. Ensure that the seat belt is not slack or twisted.

Supplementary restraints system

PRINCIPLE OF OPERATION

Introduction

In the event of a collision the airbag control unit monitors the rate of deceleration caused by the collision. This information is then used to determine whether airbags should be deployed.

Airbag deployment is dependent on the rate at which the passenger compartment changes speed following the collision. The circumstances affecting different collisions (vehicle speed, angle of impact, type and size of object hit, etc) vary considerably, and will affect the rate of deceleration accordingly.

The Supplementary Restraint System (SRS) components include :-

- SRS warning indicator.
- Rotary coupler.
- Airbag modules.
- Seat belt pre-tensioners.
- Airbag diagnostic control unit.
- Crash sensors.
- Airbag wiring harnesses.
- Seat occupancy sensor.

Note: *The SRS is not designed to operate as a result of:*

- Rear impacts.
- Minor front impacts.
- Minor side impacts.
- Heavy braking.
- Driving over bumps and pot holes.

Therefore, it follows that considerable superficial damage to the vehicle can occur without causing the airbags to deploy.

Supplementary restraints system

Airbags

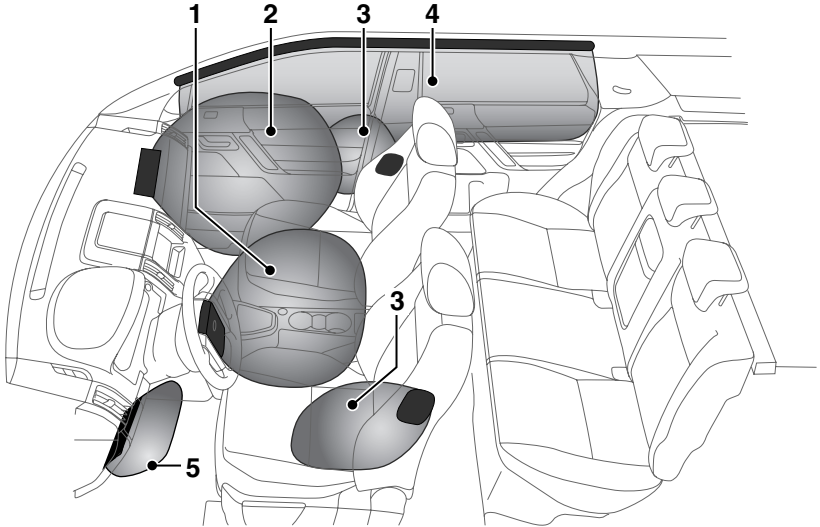

E82660

1. Driver's airbag.
2. Front passenger airbag.
3. Seat mounted side airbags.
4. Curtain airbags.
5. Knee-bolster airbag.

WARNINGS



High speed impacts may cause serious injury or death irrespective of safety features fitted to a vehicle. Always drive with caution and consideration for the vehicle's characteristics, road and weather conditions, and do not exceed any speed limits in force.



Seat belts should be worn at all times, by the driver and passengers in all seating positions. The airbag SRS cannot provide protection in some types of impact. Under these circumstances the only protection will be provided by a correctly worn seat belt.

WARNINGS



Airbags inflate at high speeds, and can cause injuries. To minimise the risk of injury, ensure that all vehicle occupants wear correctly positioned seat belts, sit correctly in the seats, and position the seats as far back as practical.



Ensure that a gap is maintained between the side of the vehicle, and the head and torso. This will enable unobstructed inflation of the curtain, and seat mounted side airbags.



Airbag inflation takes place instantaneously, and cannot protect against the effects of secondary impacts. Under these circumstances the only protection will be provided by a correctly worn seat belt.

Supplementary restraints system

WARNINGS



Phone systems should only be installed by qualified persons familiar with the operation of, and requirements for, vehicles fitted with SRS. If you are in any doubt, seek advice from your Land Rover Dealer/Authorised repairer.

Note: *The location points of airbags fitted to the vehicle are marked by the word AIRBAG embossed into the trim.*

Always contact your Land Rover Dealer/Authorised repairer if :-

- An airbag inflates.
- The front or sides of the vehicle are damaged.
- Any part of the SRS shows signs of cracking or damage, including trim covering airbags.

Airbag operation

WARNINGS



For the airbags to operate correctly the roof lining and door post trims must be in good condition, correctly fitted, and free from obstruction. Any damage, wear, or incorrect fitment should be referred to your Land Rover Dealer/Authorised repairer as soon as possible for examination and repair.



Do not allow passengers to obstruct the operation of the airbags by placing any part of their person, or any objects, in contact with, or close to, an airbag module. Airbags deploy at very high speeds, and can cause serious injury or death if objects or occupants are within the area of deployment.

Airbags cannot deploy correctly if they are obstructed. Examples of obstructions are :-

- Any part of an occupants body in contact with, or close to, an airbag cover.

- Objects placed on, or close to, an airbag cover.
- Clothing, sun screens, or other material hanging from grab handles.
- Clothing, cushions, or other material, covering seat mounted airbags.
- Seat covers which are not approved by Land Rover, or specifically designed for use with seat mounted airbags.

This list is not exhaustive, and it remains the responsibility of the driver and passengers to ensure that the airbags are not obstructed in any way.

Deployment and deflation

In the event of a collision the airbag control system monitors the rate, and direction of deceleration. If required to supplement the seat belts, airbags will be deployed as appropriate.

Front airbags

The front passenger's, and driver's airbags are able to deploy in two stages depending on the severity of the frontal impact. In a severe impact the airbags inflate fully to offer maximum protection. In a lesser impact full deployment is not required, so the airbags are partially inflated.

Side and curtain airbags

Side and curtain airbags are designed to offer increased protection for the torso and head in a side impact. The curtain airbags deflate at a slower rate than the front, or side airbags to afford greater protection from serious head injuries.

Supplementary restraints system

Airbag deployment effects

WARNINGS



When an airbag inflates a fine powder is released. This is normal, and not an indication of a malfunction. However, the powder may cause irritation to the skin, and should be thoroughly flushed from eyes, and any cuts or abrasions.



After inflation some airbag components are at high temperatures. To prevent injury, do not touch the airbag components until they have cooled.



In order to react with sufficient speed, airbags are deployed by an explosive charge. Consequently airbag deployment is accompanied by a very loud noise which may cause discomfort and temporary loss of hearing.

AIRBAG WARNING LAMP



The airbag warning indicator is mounted in the instrument pack, and will illuminate as a bulb check when the ignition is turned on.

If any of the following warning indicator conditions occur, the vehicle should be checked by your Land Rover Dealer/Authorised repairer immediately.

- The warning indicator fails to illuminate when the ignition is turned on.
- The warning indicator fails to extinguish within six seconds of the ignition being turned on.
- The warning indicator illuminates at any time other than the bulb check, when the ignition is turned on.

WARNING



If the warning indicator signals that a fault is present in the system, do not use a child restraint on the front passenger seat. Doing so will increase the risk of death or serious injury to the child.

Supplementary restraints system

DISABLING THE PASSENGER AIRBAG

Note: The passenger airbag should be disabled only when a rearward facing child restraint is fitted to the front passenger seat.

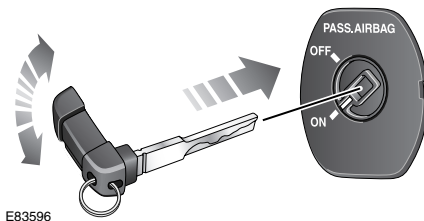
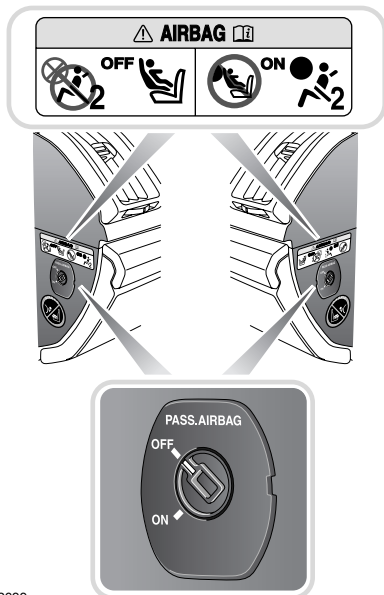

To disable the passenger airbag :-

1. Remove the emergency key from the remote control. See **USING THE KEY** (page 40).
2. Insert the end of the key blade into the slot in the switch and rotate the switch to the off position.

WARNING



As soon as the child seat is removed from the front passenger seat the airbag must be turned on. Failure to do so will put any front seat passengers at greater risk of death or serious injury in the event of a frontal impact.

WARNINGS



Crash test data and statistics, show that the safest place for a child to be restrained, is in a child seat correctly fitted to the vehicle's rear seat.



Do not use a child restraint on a seat protected by an operational airbag in front of it. Doing so presents a high risk of death or serious injury to the child in the event of an accident.



Do not fit a child restraint to the front passenger seat if the SRS warning light illuminates continuously with the ignition on.

Supplementary restraints system

Operational status indicator



E82785

WARNING



When checking the operational status of the front passenger airbag, ensure that the ignition is switched on.

The passenger airbag operational status indicator illuminates yellow when the airbag has been disabled.

Note: The indicator will only illuminate when the ignition is turned on, or the engine is running.

AIRBAG SERVICE INFORMATION

WARNINGS



Do not attempt to service, repair, replace, modify, or tamper with, any part of the SRS. This includes wiring or components in the vicinity of SRS components. Doing so may cause the system to trigger, or render the system inoperative, either of which may result in death or serious injuries.



Do not use any electrical test equipment, or devices in the vicinity of SRS components or wiring. Doing so may cause the system to trigger, or render the system inoperative, either of which may result in death or serious injuries.

All of the following operations should only be carried out by a Land Rover Dealer/Authorised Repairer, or suitably qualified person :-

- Removal or repair of any wiring or component in the vicinity of any SRS components.
- Installation of electrical, or electronic, equipment and accessories.
- Modification to the front or sides of the vehicle exterior.
- Attachment of accessories to the front or sides of the vehicle.

Child safety

CHILD SEATS

WARNINGS

 Do not use a child restraint on a seat with an operational airbag in front of it. There is a risk of death or serious injury when the airbag deploys.

 Crash statistics show that children are safest when properly restrained on the rear seat.

 Do not use a forward facing child seat until the child using it is above the minimum weight of 9 kg (20 lb.) and able to sit up unaided. Up to the age of two, a child's spine and neck are not sufficiently developed to avoid injury in a frontal impact.

 Do not allow a baby or infant to be held or carried on the lap. The force of a crash can increase effective body weight by as much as thirty times, making it impossible to hold onto the child. Children typically require the use of a booster seat appropriate to their age and size, thereby enabling the seat belts to be properly fitted, reducing the risk of injury in a crash. Children could be endangered in a crash if their child restraints are not properly secured in the vehicle.

 Do not use a child seat that hooks over the seat back. This type of seat cannot be satisfactorily secured and is unlikely to be safe for your child.

It is very important for all infants and children under 12 years of age to be restrained in a suitable child safety seat appropriate to their age and size.

If it is essential that a child travels in the front passenger seat, Land Rover recommends that the following preparations are made before fitting the child restraint.

- Disable the front passenger airbag. See **DISABLING THE PASSENGER AIRBAG** (page 62).
- Adjust the front passenger seat fully rearwards.
- Adjust the lumbar support to its minimum support position.
- Adjust the seat cushion to its highest position. If cushion rake adjustment is possible, adjust it to its lowest position.
- Adjust the seat belt adjustable upper anchorage to its lowest position.

WARNING

 Original text according to ECE R94. 01. Extreme hazard! Do not use a rearward facing child restraint on a seat protected by an operational airbag in front of it!



E79258

This symbol is affixed to the end of the fascia on the passenger side. Its purpose is to warn against the use of a rear facing child seat when the front passenger airbag is fitted and operational.

Child safety

Child restraint check list

Every time a child travels in the vehicle observe the following :-

- Use appropriate child restraints.
- Carefully follow the restraint system manufacturers instructions.
- Adjust the harnesses for every child on every trip.
- Ensure that all slack is removed from the adult seatbelt.
- Always attach the top tether when installing an ISOFIX seat.
- Always check the security of the child restraint. See **ISOFIX ANCHOR POINTS** (page 67).
- Do not dress a child in bulky clothing, or place any objects/padding between the child and the restraint.
- Regularly check the fit and condition of child restraints. If the fit is poor, or wear/damage is visible replace the restraint immediately.
- Set a good example - always wear your seat belt.

Child safety

Child safety seating and positions

Mass group.	0 = Up to 10 kg (22 lb).	0+ = Up to 13 kg (29 lb).	I = 9-18 kg (20-40 lb).	II = 15-25 kg (40-67 lb).	III = 25-36 kg (67-80 lb).
Seating positions.					
Front passenger. *	UF*	UF*	U*	U*	U*
Rear outboard.	U	U	U	U	U
Rear centre.	U	U	U	U	U

- U = Suitable for universal category restraints approved for this mass group.
- UF = Suitable for Forward-facing universal category restraints approved for this mass group.

* Always ensure that the passenger airbag has been disabled before using a child restraint in this seating position. The seat back needs to be adjusted to the fully upright position. See

DISABLING THE PASSENGER AIRBAG

(page 62).

CAUTION



Information given within the table is correct at the time of going to press. However, availability of child restraints may change. Please consult your Land Rover Dealer/Authorised Repairer for the latest recommendation.

Note: *The legislation which governs how and where children should be carried when travelling in a vehicle, is subject to change. It is the responsibility of the driver to comply with all regulations in force.*

BOOSTER CUSHIONS

In a situation where a child is too large to fit into a child safety seat, but is still too small to safely fit the three point belt properly, a booster seat is recommended for maximum safety. Follow the manufacturer's instructions for fitting and use, then adjust the seat belt to suit.

Child safety

ISOFIX ANCHOR POINTS

WARNINGS

 Do not attempt to fit ISOFIX restraints to the centre seating position. The anchor bars are not designed to hold an ISOFIX restraint in this position.

 If the restraint is not correctly anchored, there is a significant risk of injury to the child in the event of a collision or emergency braking.

 Child restraint anchorages are designed to withstand only loads imposed by correctly fitted child restraints. Under no circumstances are they to be used for adult seat belts, harnesses, or for attaching other items or equipment to the vehicle.

 If removing a head restraint in order to fit a child restraint, always secure the head restraint when storing it. If left loose in the vehicle it may cause death or serious injury during sudden braking or an impact.

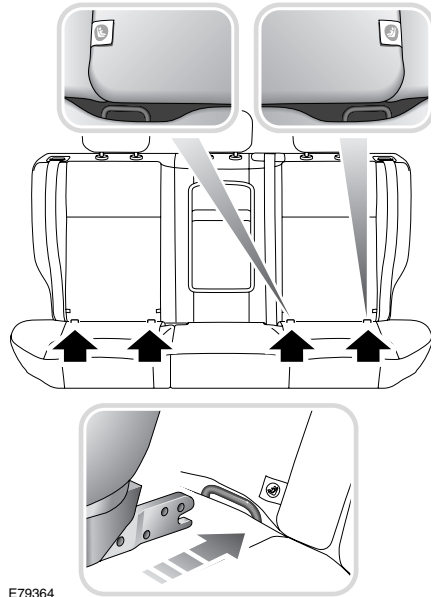

E79364

Both of the outer seat positions on the rear seat are equipped to accept ISOFIX restraints.



This symbol is shown on a label sewn into the seats to indicate the position of the ISOFIX lower anchorages.

Child safety

ISOFIX child seats

Mass group	Size classes	Fixtures	Rear outboard seats
Carrycot	F/G	ISO L1/L2	X
0 = Up to 10 kg (26.8 lb)	E	ISO R1	IL*
0+ = Up to 13 kg (34.8 lb)	C/D/E	ISO R1/R2/R3	IL*
I = 9 to 18 kg (24 to 48 lb)	C/D A/B1/B	ISO R2/R3 ISO F2/F2X/F3	IL* IUF
II = 15 to 25 kg (40.2 to 67 lb)	-	N/A	N/A
III = 22 to 36 kg (59 to 96.5 lb)	-	N/A	N/A

- IUF = Suitable for ISOFIX forward child restraint systems of universal category approved for use in the mass group.
- IL = These ISOFIX child restraint systems are of the specific vehicle, restricted, or semi-universal categories.
- * = Child seats suitable for use in these locations are Britax Cosy-Tot, and Römer Baby Safe ISOFIX.

Installing an ISOFIX child seat

To install an ISOFIX child seat :-

1. Raise or remove the head restraint.
2. Lift the velcro flap to expose the ISOFIX locking mechanism.
3. Slide the child seat into the locking mechanism.
4. Test the security of the child restraint. To do this attempt to pull the restraint away from the vehicle seat and twist the restraint from side to side. Even if the restraint appears secure you should still check the anchor points visually to ensure correct attachment.

Note: Always ensure that if an upper tether is provided, it is fitted and tightened correctly.

Tether anchorages

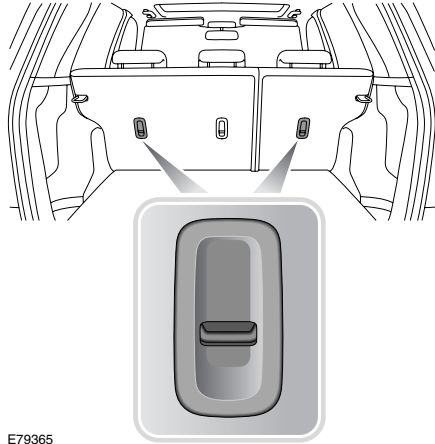

E79365

WARNING

 Child restraint anchorages are designed to withstand only those loads imposed by correctly fitted child restraints. Under no circumstances are they to be used for adult seat belts, harnesses or for attaching other equipment or items to the vehicle.

Child safety

Tether anchorages are provided at each rear outboard seating position.

Note: A tether anchorage is provided for the centre seat position, but should only be used when a non- ISOFIX child seat with a tether is used in this seating position.

CHILD SAFETY LOCKS

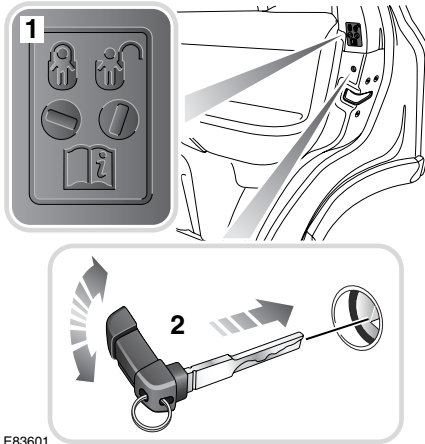

E83601

Child safety locks are fitted to the rear doors to allow you to prevent accidental opening of the doors when the vehicle is in motion.

If children are to be carried in the rear seat positions, it is recommended that the rear door interior handles are disabled.

Note: For convenience the rear door interior handles should be re-enabled when carrying adult passengers in the rear seat positions.

To change the child lock settings :-

1. Open the door to access the child safety lock.
2. Insert the emergency key into the slot, and rotate a quarter of a turn to enable, or disable the interior door handle as required.

Steering wheel

ADJUSTING THE STEERING WHEEL

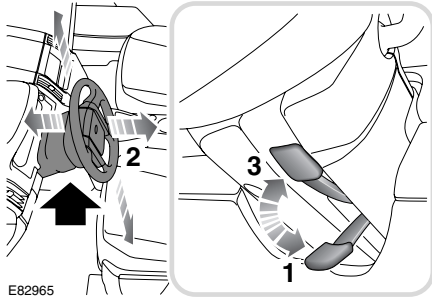

WARNINGS



Never adjust the steering wheel position whilst the vehicle is in motion. Doing so will reduce control of the vehicle, and may cause unpredictable steering movements.



After adjusting the steering wheel position, ensure that the locking lever is returned to the fully up position. Failure to do so will reduce control of the vehicle, and may cause unpredictable steering movements.

To adjust the steering wheel :-

1. Release the locking mechanism by pulling the lever down.
2. Adjust the steering wheel to the desired position.
3. Push the locking lever back up, and ensure that it's fully home.

AUDIO CONTROL

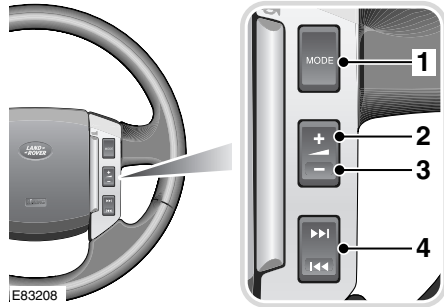

1. Press to switch between radio, CD, or AUX.
2. Press to increase volume.
3. Press to decrease volume.
4. Press and release to scroll through preset radio stations or CD tracks. Press to search up or down for the next or previous radio station/CD track.

Steering wheel

Audio control using the telephone buttons

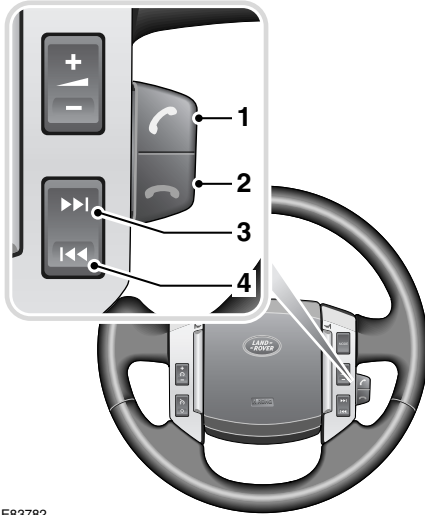

E83782

When the telephone system is inoperative the telephone controls on the steering wheel can be used to operate the audio system.

1. Operates as a menu control. Press to enter or confirm menu selections.
2. Operates as an exit control. press to return to the previous screen or menu.
3. Operates as forward motion of the rotary control. Press to scroll forward through menu items.
4. Operates as backward motion of the rotary control. Press to scroll back through menu items.

Lighting

LIGHTING CONTROL

Main switch panel

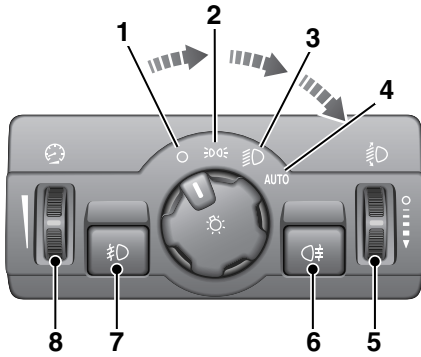

E80804

1. Headlamps/side lamps off.
2. Side lamps on.
3. Headlamp dipped beam on.
4. Autolamps on.
5. Headlamp levelling control.
6. Rear fog lamps on/off.
7. Front fog lamps on/off.
8. Facia illumination dimmer control.

Main beam

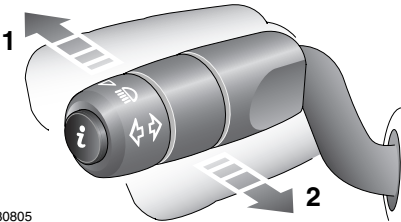

E80805

1. When the headlamp dipped beams are switched on, push the indicator stalk to change to full beam.

2. To flash the headlamps at anytime, briefly pull the indicator stalk and release it.



When the headlamp main beam is on, the main beam warning indicator will illuminate.

Note: Do not use main beam where it may dazzle other road users.

Headlamp courtesy delay

This feature enables the driver to keep the area in front of the vehicle illuminated for a short period after the vehicle has been locked.

1. Switch off the ignition.
2. Pull the indicator stalk (main beam flash) towards the steering wheel, and exit the vehicle as normal.



The headlamps will remain on for thirty seconds. The length of time that the headlamps remain on, can

be adjusted by your Land Rover Dealer/Authorised Repairer.

FRONT FOG LAMPS



E80808

Front fog lamps will only operate when headlamp dipped beam, or Auto lamps are selected. Press the front fog lamp button to switch on, press again to switch off.

Lighting

REAR FOG LAMPS

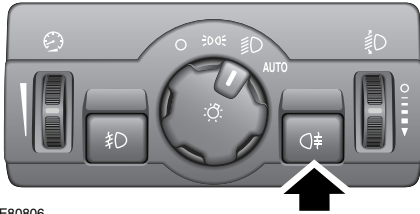

E80806

Rear fog lamps will only operate when headlamp dipped beam, or Auto lamps are selected. Press the rear fog lamp button to switch on, press again to switch off.

ADJUSTING THE HEADLAMPS

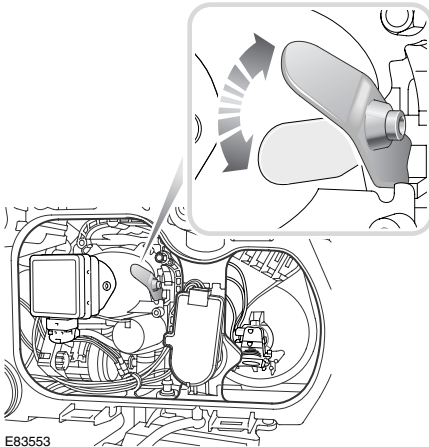

E83553

Note: The headlamps must be removed in order to change the beam pattern. See **CHANGING A BULB** (page 77).

The tourist lever allows you to adjust the headlamps to the correct beam pattern for driving in countries where vehicles drive on the left, or the right.

When new, the lever will be set to the correct position for the country in which the vehicle is sold. To change the pattern for driving on the other side of the road, move the lever to the opposite position.

Note: When changing the beam pattern using the lever, ensure that you change the lever position on both headlamps.

HEADLAMP LEVELLING

Halogen headlamps

Use the headlamp levelling control to account for vehicle loading changes.

Vehicle load	Switch position
Driver only	0
Driver and front seat passenger	0
Driver and passengers in all seats	1
Maximum gross vehicle weight	2
Maximum rear axle load	2.5

Xenon headlamps

Headlamp levelling is adjusted automatically if Xenon headlamps are fitted.

Lighting

HAZARD WARNING FLASHERS

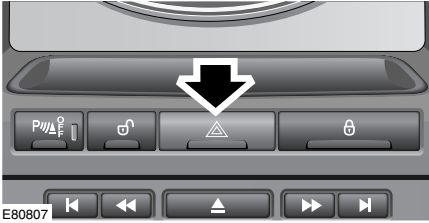

Press the switch to turn the hazard warning lamps on. When the hazard warning lamps are operating, the indicator warning lamps will flash in time with the hazard warning lamps.

Note: Hazard warning lamps can be used when the ignition is on or off.

ADAPTIVE FRONT LIGHTING SYSTEM (AFS)

1

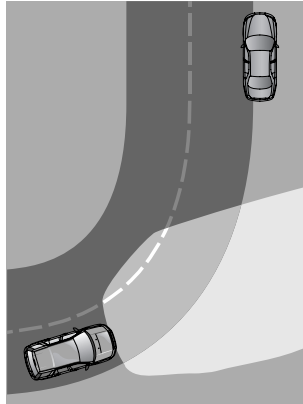

2

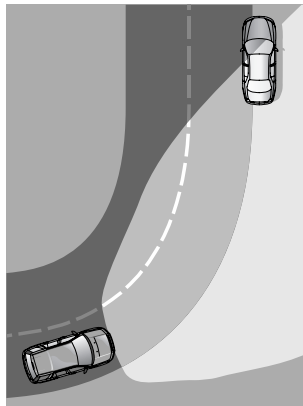

E80823

1. Vehicle without AFS.
2. Vehicle with AFS.

When cornering using dipped beam, AFS will adjust the headlamp beams to provide improved illumination in the direction of travel.

AFS is deactivated when :-

- reverse gear is selected.
- the vehicle is stationary.
- daylight running lamps are on.

Lighting



If a system fault is detected the headlamps will attempt to move to the central position, and remain stationary. The AFS warning indicator will illuminate to indicate that a fault is present.

If the warning indicator illuminates, contact your Land Rover Dealer/Authorised Repairer as soon as possible.

DIRECTION INDICATORS

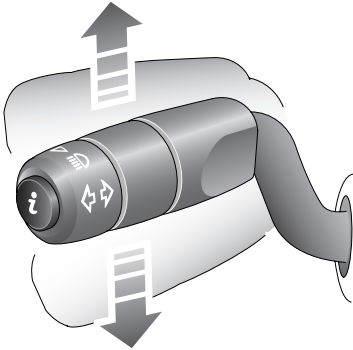

E80822

The direction indicators are operated using the indicator stalk. Move the stalk up or down, to indicate turning right or left.

The indicators will operate three times if the stalk is briefly pushed up or down.

Lighting

INTERIOR LAMPS

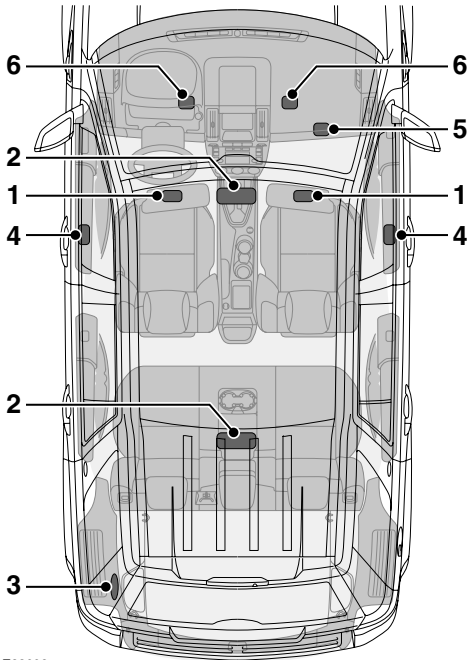

E83602

1. Sun visor lamps. Switch on or off as required using the switch.
2. Map reading/interior lamps. The switch allows them to be turned on, off, or set to operate when the doors are opened.
3. Luggage compartment lamp. Automatically illuminates when the doors are opened.
4. Puddle lamps. Automatically illuminate when the doors are opened.
5. Glove box lamp. Automatically illuminates when the glove box is opened.
6. Footwell lamps. Automatically illuminate when the doors are opened.

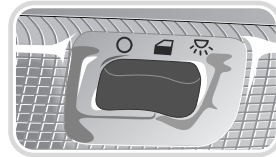
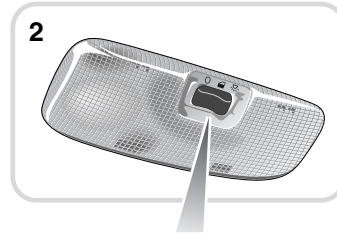
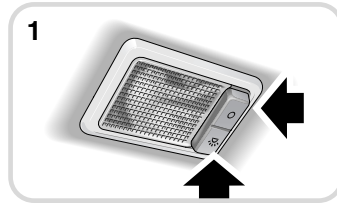

APPROACH LAMPS

The approach lamp feature turns on the parking lamps, indicator lamps, door mirror lamps, number plate lamps, interior lamps, and puddle lamps remotely. This feature is activated with the remote control. See **USING THE REMOTE CONTROL** (page 41).



The length of time which the lights remain on can be adjusted by your Land Rover Dealer/Authorised

Repairer.

Lighting

CHANGING A BULB

General information

CAUTION



Always replace bulbs with the correct type and specification. If you are in any doubt contact your Land Rover

Dealer/Authorised Repairer for advice.

Note: *In certain territories it is a legal requirement to carry spare bulbs. A replacement bulb kit is available as an approved accessory from your Land Rover Dealer/Authorised Repairer.*

Halogen bulbs

Halogen bulbs are used for main beam, dipped beam, and front fog lamps. Take care not to touch the glass part of the bulb with your fingers; always use a cloth to handle the bulb. If necessary use methylated spirits to remove finger prints.

Xenon lamps

WARNINGS



Replacement or maintenance of Xenon lamps should only be carried out by suitably qualified personnel.



High voltage is required to ignite the gas and metal vapour which are used to power Xenon lamps. Contact with this voltage can cause serious injuries.



Bi-Xenon lamp units operate at a very high temperature. Ensure that the lamp units have cooled before attempting to touch them.



Xenon lamp units contain Mercury which is highly toxic, and can be extremely harmful.



Seek advice about the correct disposal of Bi-Xenon lamp units from a Land Rover

Dealer/Authorised Repairer, or your local authority.

Lighting

Removing the headlamp unit

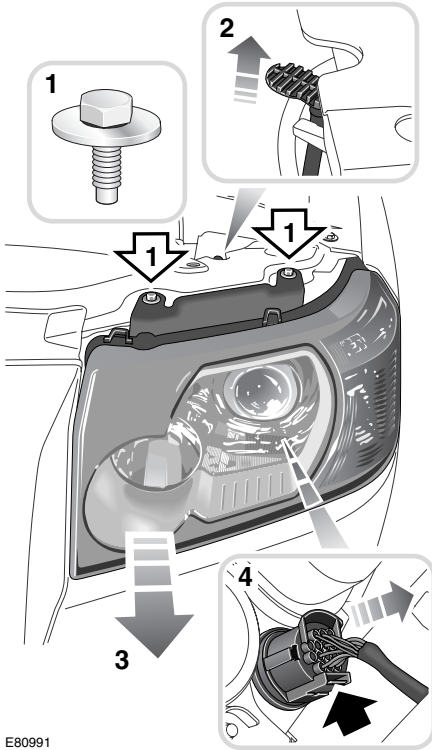

CAUTION



Do not place the lamp unit face down on hard or abrasive surfaces. Doing so may scratch the surface of the lens.

E80991

In order to change a headlamp unit bulb, you must first remove the headlamp unit.

To remove the headlamp unit :-

1. Undo and remove the two retaining bolts.
2. Pull up the locking lever to release the headlamp unit.
3. Pull the headlamp unit forward sufficiently to allow access to the rear of the unit.
4. Disconnect the electrical plug from the back of the headlamp by pressing in the locking tab and pulling the connector out.

Lighting

Headlamp unit bulbs

Xenon dipped/main beam with supplementary halogen main beam

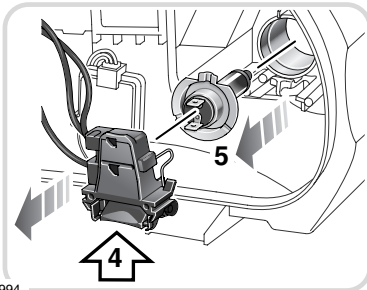
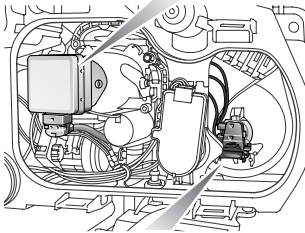
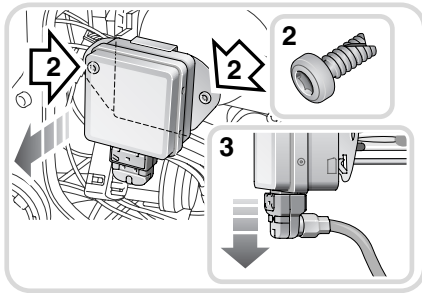
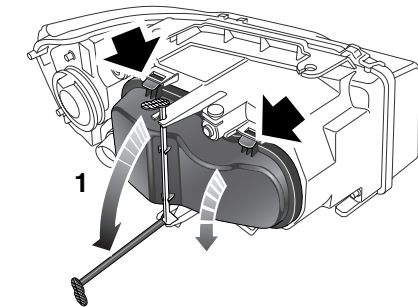

E80994

With the headlamp unit removed :-

1. Unclip the locking lever, press down the two tabs and remove the cover.
2. Undo the two retaining screws and remove the Xenon unit.
3. Remove the electrical connection from the Xenon unit.
4. Pull the halogen main beam electrical connector off of the supplementary halogen main beam bulb.
5. Unclip the halogen bulb and remove it from the unit.

Lighting

Halogen dipped and main beam

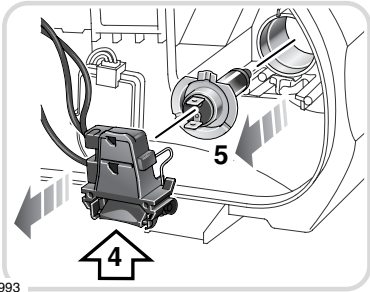
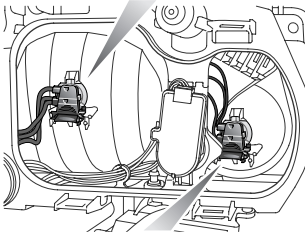
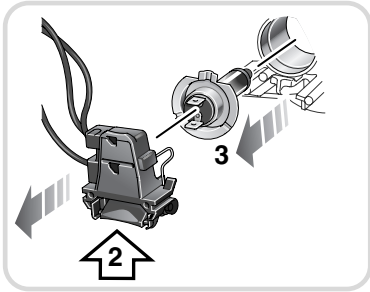
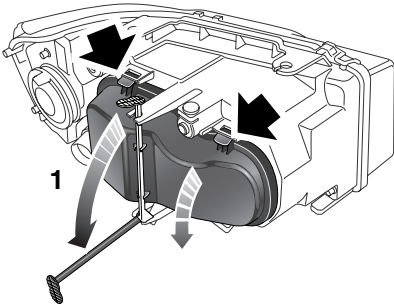

With the headlamp unit removed :-

1. Unclip the locking lever, press down the two tabs, and remove the cover.
2. Pull the halogen dipped beam electrical connector off of the bulb.
3. Unclip the bulb and remove it from the unit.
4. Pull the halogen main beam electrical connector off of the bulb.
5. Unclip the bulb and remove it from the unit.

E80993

Lighting

Side lamp and indicator bulbs

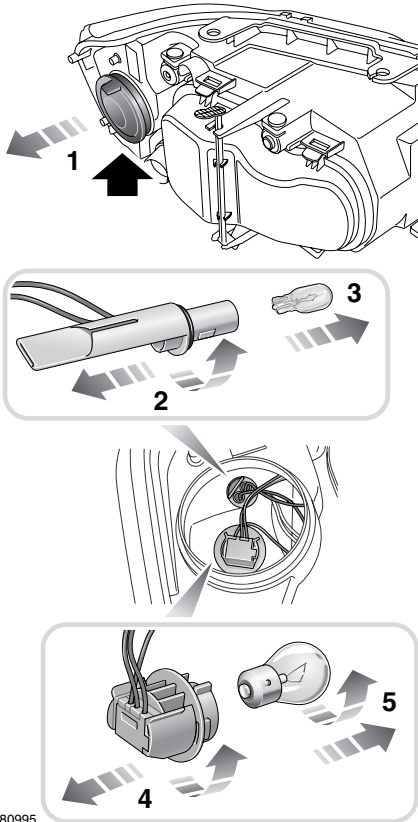

E80995

With the headlamp unit removed :-

1. Remove cover.
2. Twist the side lamp bulb holder and remove it from the lamp unit.
3. Pull the bulb out of the holder.
4. Twist the indicator bulb holder, and remove it from the lamp unit.
5. Press the bulb into the holder, then twist it and remove from the holder.

Front fog lamp

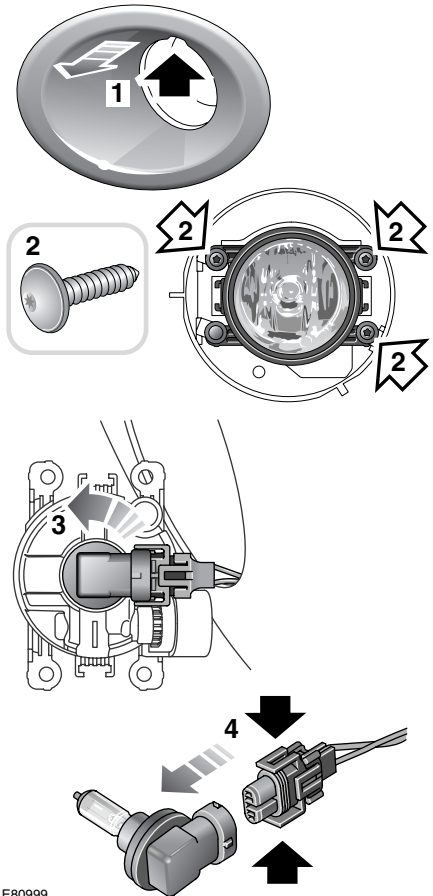

E80999

1. Remove the trim from the fog lamp.
2. Undo the three retaining screws, and remove the lamp unit.
3. Rotate the bulb holder (anti-clockwise) and remove from the lamp unit.
4. Press the two clips together, and remove the electrical connection.

Lighting

Removing the rear lamp unit

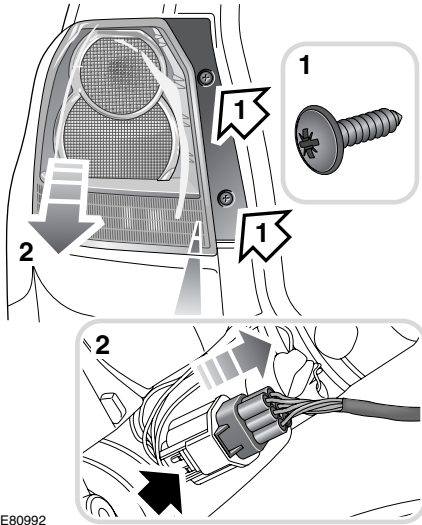

E80992

In order to change a rear lamp unit bulb, you must first remove the rear lamp.

To remove the rear lamp :-

1. Undo, and remove the two retaining screws.
2. Remove the lamp unit and disconnect the electrical connection.

CAUTION



Do not place the lamp unit face down on hard or abrasive surfaces. Doing so may scratch the surface of the lens.

Rear lamp bulbs

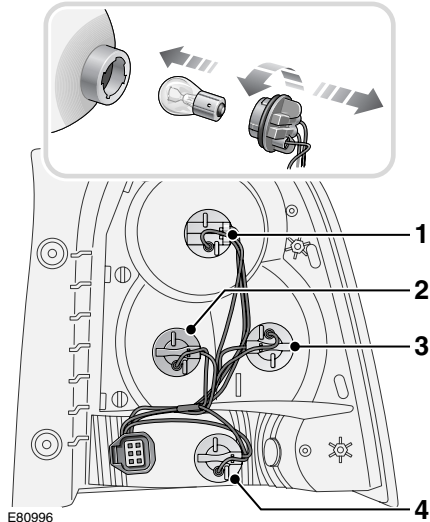

E80996

1. Stop/tail lamp.
2. Direction indicator.
3. Reverse lamp.
4. Rear fog lamp.

All of the rear lamp bulbs are removed in the same way.

- Rotate the bulb holder (anti-clockwise) and remove from the lamp unit.
- Press the bulb into the holder, rotate it, and remove from holder.

Lighting

High level brake lamp

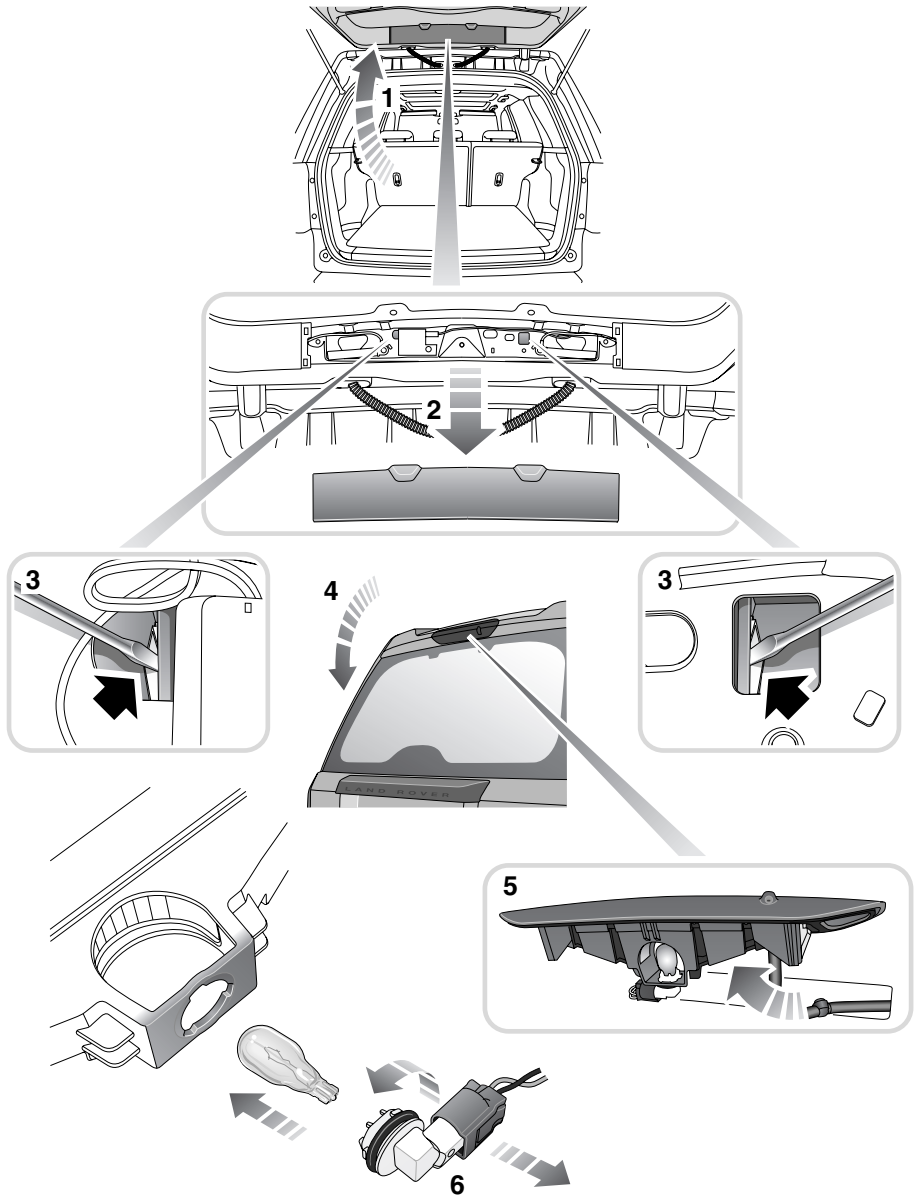

E83610

Lighting

1. Open the tailgate.
2. Remove the interior trim cover.
3. Using a suitable implement, press in the retaining clips.
4. Close the tailgate.
5. Remove the lamp unit from the tailgate.
6. Rotate the bulb holder and remove it from the lamp unit, then pull the bulb out of the holder.

Number plate lamp bulb

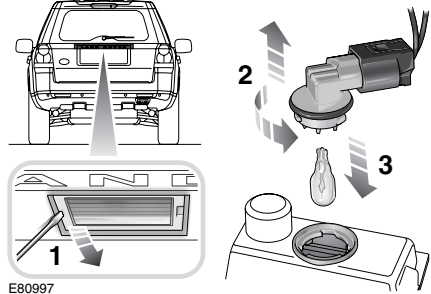

1. Using a suitable tool, lever out the side of the lamp unit and remove it from the tailgate.
2. Rotate the bulb holder and remove it from the lamp.
3. the bulb from the holder.

Side repeater lamp

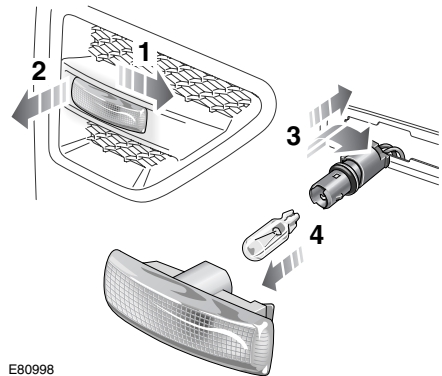

1. Slide the lens forward and lift the rear edge.
2. Remove the lamp unit.
3. Rotate the bulb holder and remove from the lamp unit.
4. Pull the bulb out of the holder.

Lighting

Interior lamp bulbs

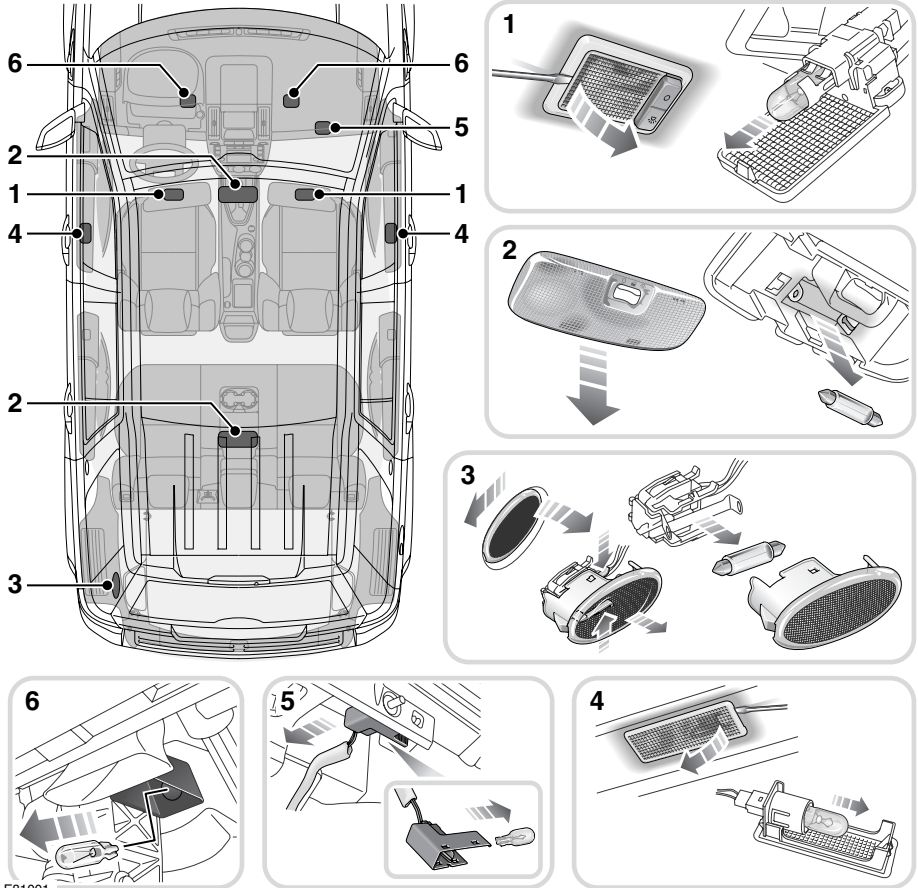

E81001

1. Sun visor lamps.
2. Map/reading lamps.
3. Luggage compartment lamp.
4. Puddle lamps.
5. Glove box lamp.
6. Footwell lamps.

To access and replace the lamp bulbs follow the directions given in the illustration.

Lighting

BULB SPECIFICATION CHART

CAUTION



Before attempting to replace a bulb, ensure that both the affected lamp, and the vehicle's ignition, are turned off. If the circuit is live a short circuit can occur which may damage the vehicle's electrical system.

Lamp	Specification	Power (Watts)
Halogen headlamp (Dip and Main beam).	H7	55
Xenon headlamp (Dip and Main beam).	D1S	35
Front side lamps.	W5W	5
Front direction indicators.	PY21W	21
Rear direction indicators.	PY21W	21
Front fog lamps.	H11	55
Side repeater lamps.	W5W	5
Reverse lamps.	P21W	21
Rear fog lamps.	P21W	21
Stop/tail lamps.	P21/5W	21/5
High mounted stop lamp	W16W	16
Number plate lamps.	W5W	5
Puddle lamps.	W5W	5
Interior lamps.	W5W	5
Luggage/footwell lamps.	W5W	5
Luggage/tailgate lamps.	W5W	5
Glovebox lamp.	W5W	5
Vanity mirror lamp.	W5W	5

Wipers and washers

WINDSCREEN WIPERS

CAUTIONS

- ❗ Do not operate the windscreen wipers on a dry screen. The drag on the wiper mechanism may cause damage.
- ❗ In freezing, or very hot conditions ensure that the wipers have not stuck to the windscreen before operating. The drag on the wiper mechanism may cause damage.
- ❗ Remove any snow, ice, or frost, from the windscreen, around the wiper arms and blades, and the screen scuttle before operating the wipers. Snow and ice can cause damage to the wiper mechanism if left uncleared.

Note: If the wiper blades do become stuck, or jammed, an electronic cut-out may temporarily halt the operation of the wipers. If this happens, switch off the wipers and the ignition. Clear any obstructions, and free the wiper blades before attempting to switch on the ignition.

Wiper operation

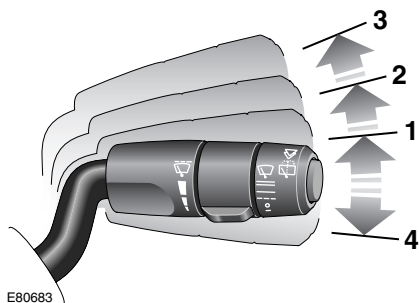

1. Rain sensor/intermittent variable delay.
2. Low speed wipe.
3. High speed wipe.
4. Single wipe, pull down and release to operate.

Intermittent variable delay

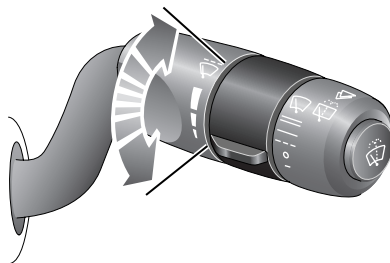

The interval in between wipes can be adjusted to suit the conditions. Rotate the control upwards to increase the time between wipes, and down to decrease the time between wipes.

Speed-dependent mode

If the vehicle's speed drops below 2 km/h (1.2 mph) with the wipers operating, the wiper frequency automatically reduces. The wipers will switch to the next lowest speed. When the vehicle's speed increases to over 8 km/h (5 mph), the original wiper speed setting is restored automatically.

RAIN SENSOR

CAUTION

- ❗ Ensure that the wipers are switched off before entering a car wash. If the rain sensitive wipers operate during the car washing process damage may occur to the wiper mechanism.

Wipers and washers

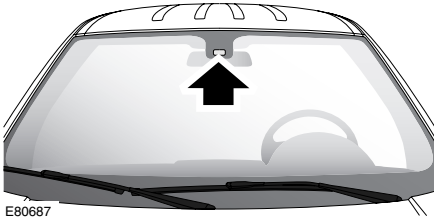

The rain sensor is able to detect the presence and amount of rain/dirt/snow on the windshield.

Operation

To use the rain sensitive wipers, move the wiper stalk to position 1 rain sensor/intermittent variable delay.

Adjusting the sensitivity

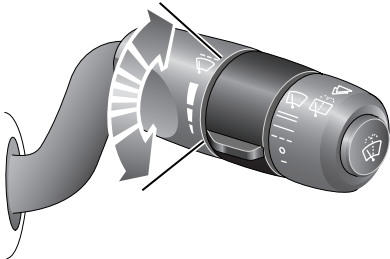

Rotate the control upwards to increase the sensitivity, and down to reduce the sensitivity. If the sensor detects constant rain the wipers will operate continuously.

WINDSCREEN WASHERS

WARNING



Some screenwash products are flammable, do not allow screenwash to come into contact with sources of ignition.

CAUTION



Only screenwash products which are approved for automotive use should be used, and only in accordance with the manufacturers instructions.



To operate the windscreen wash press the button on the end of the wiper stalk. When the button is released, the wipers will complete two additional strokes, and then park.

HEADLAMP WASHERS

Headlamp power wash operates automatically with the windscreen wash, and will only operate if the headlamps are switched on and there is sufficient washer fluid in the reservoir.

Headlamp wash operates with every fifth operation of the screen washers, or if ten minutes have elapsed since the last operation of the screen washers, they will operate again immediately.

Note: *The headlamps are washed alternately to prevent the washer fluid from reducing the light output for both headlamps at the same time.*

Wipers and washers

REAR WINDOW WIPER AND WASHERS

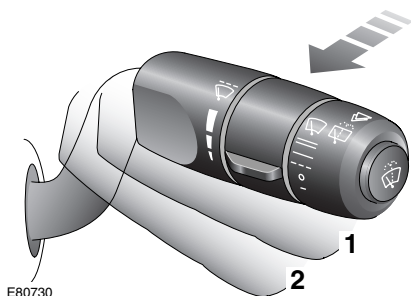

1. Intermittent wiper operation.
2. Wash wipe.

Wiper

Pull the wiper stalk back to position 1 to turn on the rear screen wiper. The wipe interval is set to six seconds.

Wash/wipe

Pull the wiper stalk to position 2 and hold it there for as long as the wash is required. The wiper will operate at the same time, and carry out two additional wiper sweeps when the lever is released.

Reversing

If reverse gear is selected while the front wipers are operating, the rear wiper will begin automatically and continue as long as reverse gear is selected.

If the rain sensor is operating the front wipers and reverse gear is selected, the rear wiper will operate automatically.

ADJUSTING THE WINDSCREEN WASHER JETS

Front

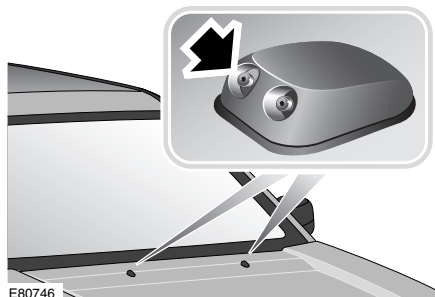

If it is necessary to adjust the direction of the front washer jets, insert the end of a needle into the jet and gently reposition it.

Note: Direct the water jet towards the centre of the windscreen. Take into account that when the vehicle is moving at speed the air flow over the bonnet will lower the jet.

Rear

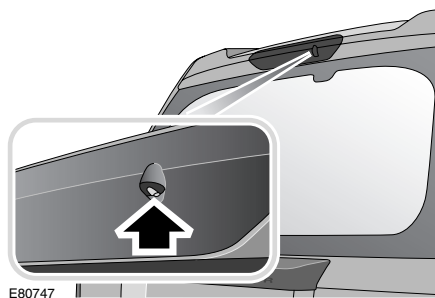

The rear washer jet is set at the factory, and cannot be adjusted.

Wipers and washers

Blocked jets

WARNING

 Do not operate the washer jets during adjustment. Windscreen washer fluid may cause irritation to the eyes and skin. Always read and observe the washer fluid manufacturer's instructions.

If a washer jet becomes blocked, use a thin strand of wire to unblock the jet by inserting the wire into the jet. Ensure that the wire is completely removed after unblocking.

CHECKING THE WIPER BLADES

WARNING

 Only use cleaning products which have been approved for use on automotive glass and rubber. Inappropriate products can cause smearing, and increase glare.

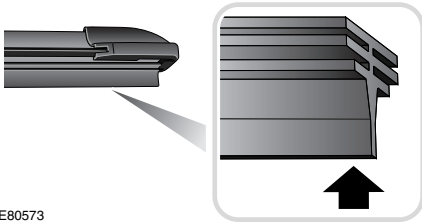



E80573

The wiping edge of the blades should be checked, and cleaned periodically. Check the blade rubber for cracks, splits, and roughness. If any damage, wear, or roughness is detected the blade should be replaced immediately to prevent damage to the glass.

Clean the blade edge by wiping with a soft cloth or sponge, using warm soapy water.

CHANGING THE WIPER BLADES

CAUTIONS

-  When checking or changing the wiper blades, they can be set to the service position, or parked normally.
-  The wipers will return to their normal parked position when the ignition is turned on. To prevent damage to the mechanism ensure that they are returned to their position against the windscreen, and that there are no obstructions, ice, or snow present on the windscreen.

Service position

CAUTION

-  If the wipers are set to the service position and left there overnight during frosty conditions, do not switch the ignition on until the wipers have been freed from frost/ice. The wipers will try to park when the ignition is switched on. If they are frozen to the screen when this occurs then this may cause damage to the mechanism.

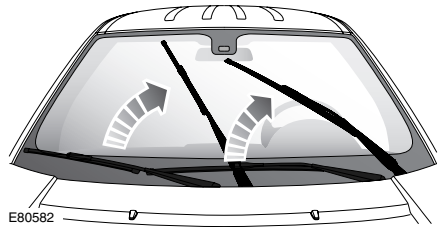

E80582

The windscreen wiper service position allows the wipers to be parked in a more accessible position. This makes it easier to change wiper blades, or free the wipers from frost/ice.

Wipers and washers

Setting the wipers

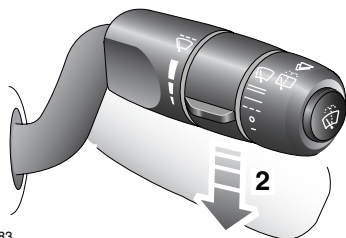
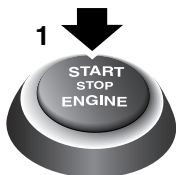

E80583

1. Switch off the ignition.
2. Within three seconds of switching off the ignition pull the wiper stalk down to the single wipe position. Hold the stalk in this position briefly, and release it.

Changing the front wiper blades

CAUTION

⚠ Only fit the correct length and type of wiper blade. Failure to do so may cause damage to the wiper system, it may also affect the operation of the rain sensor.

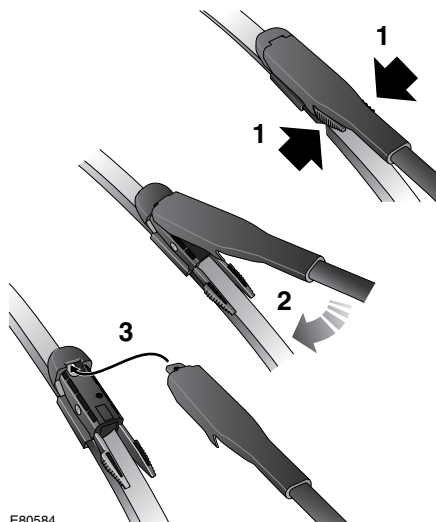

E80584

Having set the wipers to the service position, lift the wiper blade clear of the windscreen. The removal procedure for the wiper blade is as follows :-

1. Push the clips together on the underside of the wiper mounting.
2. Rotate the clips and blade away from the wiper mounting.
3. Slide the wiper blade off of the wiper arm.

To fit the new blade, follow the removal procedure in reverse.

Wipers and washers

Changing the rear wiper blades

To fit the new blade, follow the removal procedure in reverse.

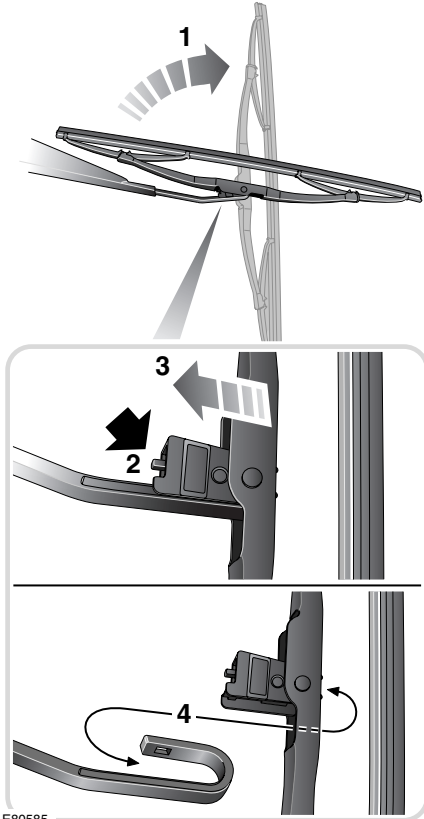

E80585

Lift the wiper blade clear of the windscreen. The removal procedure for the wiper blade is as follows :-

- 1.** Rotate the wiper blade to gain access to the retaining clip.
- 2.** Press in the retaining clip on the underside of the mounting.
- 3.** Slide blade down the wiper arm and clear of the mounting.
- 4.** Move the blade sideways and lift it clear of the wiper arm.

Windows and mirrors

ELECTRIC WINDOWS

WARNING

 All of the windows have an anti-trap protection system. However, before closing a window care must be taken to ensure that none of the occupants have any part of their body in a position where it could be trapped. Even with an anti-trap system serious injury or death can occur.

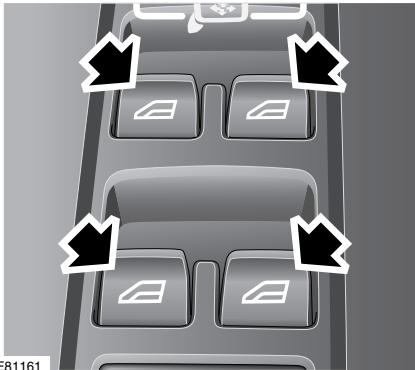

With the ignition on, or engine running, press the switch down to lower the window, pull it up to raise the window. Release the switch at any point to stop window movement.

The windows will operate for five minutes after the engine is switched off, as long as the doors are not opened.

One shot operation

WARNING

 Ensure that you remove the remote control when leaving occupants in the vehicle. This will prevent unsupervised operation of the windows, which may result in injury.

All four windows have one-shot operation. Briefly pull the switch up and release, the window will continue to raise until fully closed. Briefly press the switch down and release, the window will continue to lower until fully open. Pressing or pulling the switch again will stop the window.

Overriding anti-trap protection

Anti-trap protection will stop window movement if an obstruction or resistance is detected. Check the window and its aperture and remove any obstructions, ice, etc. If it is still necessary to raise the window, the override procedure is as follows :-

1. Attempt to close the window, anti-trap will prevent closure and lower the window slightly.
2. Within ten seconds attempt to raise the window again, anti-trap will prevent closure and lower the window slightly.
3. Attempt to close the window for a third time, this time hold the switch in the close position. The window will raise whilst the switch is held. Hold until closed.

Note: *If this procedure fails to remove the blockage, the window operation may need to be reset.*

Windows and mirrors

Window reset

The windows will need to be reset if the battery is disconnected, becomes discharged, or power supply is interrupted.

Reset as follows :-

1. Close the window fully.
2. Release the switch, then lift it to the close position and hold for two seconds.
3. Open the window fully.
4. Release the switch, then push it to the open position and hold for two seconds.
5. Lift and release the switch to operate the one touch function.
6. Repeat the procedure on each window.

Window isolator



E81162

WARNING



If children are carried in the rear seats, the isolator switch should be used to prevent operation of the windows. If the windows are operated by young children there is a risk of serious injury or death.

To prevent operation of the rear windows, press the inhibitor switch. To allow passengers control of the windows, press the switch again.

EXTERIOR MIRRORS

Note: Depending on the type of lens used, distances may be difficult to judge accurately when only using the mirrors.

Proximity mirror (Japan only)

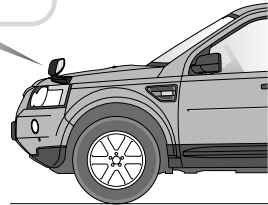
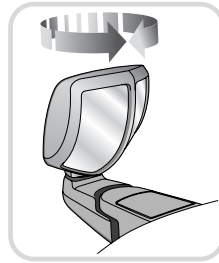

E83691

Rotate the mirror as required to give the best view of the areas in front of and beside the vehicle.

Windows and mirrors

ELECTRIC EXTERIOR MIRRORS

Adjusting and folding

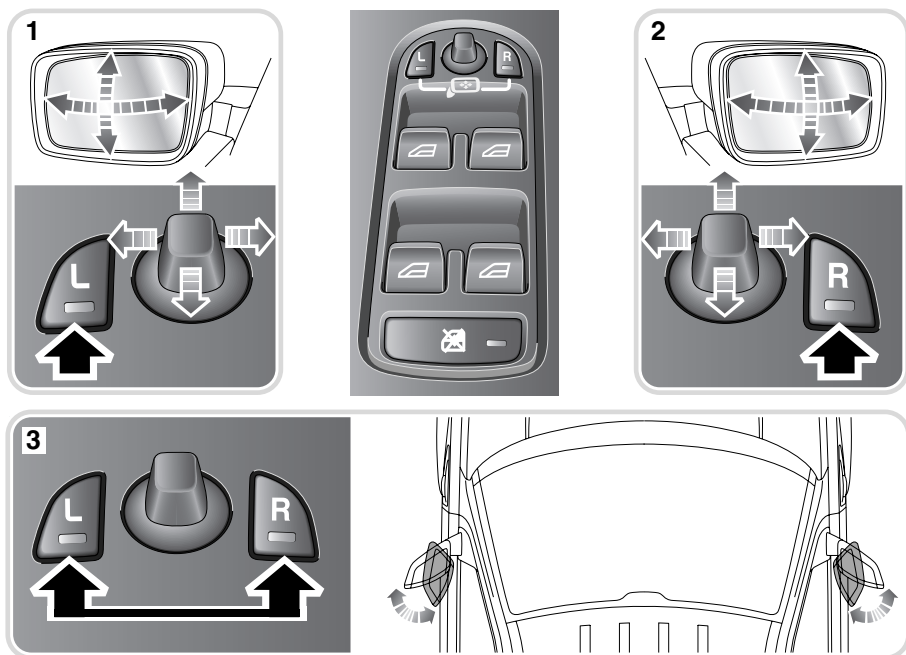

E80504

1. Left mirror adjustment.
2. Right mirror adjustment.
3. Powerfold.

Adjusting

1. Press the left or right mirror button as required. The green tell-tale light will illuminate in the button to indicate that it has been selected.
2. Move the toggle switch to adjust the mirror as required.

Folding

To fold the mirrors back press both left and right buttons at the same time. To unfold the mirrors, press both left and right buttons again.

Windows and mirrors

Note: If the mirrors are folded manually, or knocked into the folded position accidentally, the mirror head will be loose. To re-engage the mechanism, fold, then unfold the mirrors using the switches.

The system is protected by a thermal cut-out which will temporarily disable the powerfold feature if the switches are operated repeatedly. If the cut-out operates when the mirrors are folded, they can be unfolded manually.

Powerfold will only operate if the vehicle is stationary, or travelling at 20 km/h (12 mph) or less.

Automatic folding



The mirrors can be configured by your Land Rover Dealer/Authorised repairer to automatically fold when the vehicle is locked, and unfold when it is unlocked.

Note: If the mirrors were folded using the switches, they will not unfold when the vehicle is unlocked.

Mirror dip when reversing

When reverse gear is selected the driver and passenger door mirrors are automatically adjusted to provide an improved viewing angle for reversing.

The exact dipped position can be adjusted when the mirrors are dipped. The next time reverse is selected, the newly adjusted position will be selected.

When the gear selector is moved out of reverse, the mirrors will return to their previous position.

INTERIOR MIRROR

Auto dimming

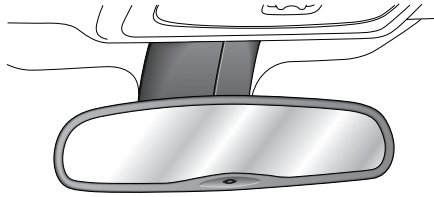

E80553

The interior mirror dimming is adjusted automatically according to the amount of ambient light when the ignition is on. If reverse gear is selected, the automatic dimming feature is turned off to allow maximum visibility for reversing.

Note: If the mirror becomes detached from the windscreen it should be reattached by a Land Rover Dealer/Authorised Repairer.

Note: If the rear screen is obscured, or the light falling on the mirror is reduced by an obstruction, the automatic dimming feature may not operate correctly.

Manual dimming

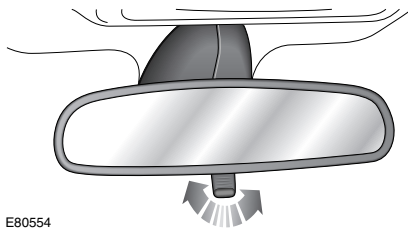

E80554

To dim the light levels reflected by the mirror, push the lever forward. To return it to normal light levels, pull the lever back.

Instruments

INSTRUMENT PANEL OVERVIEW

Instrument panel

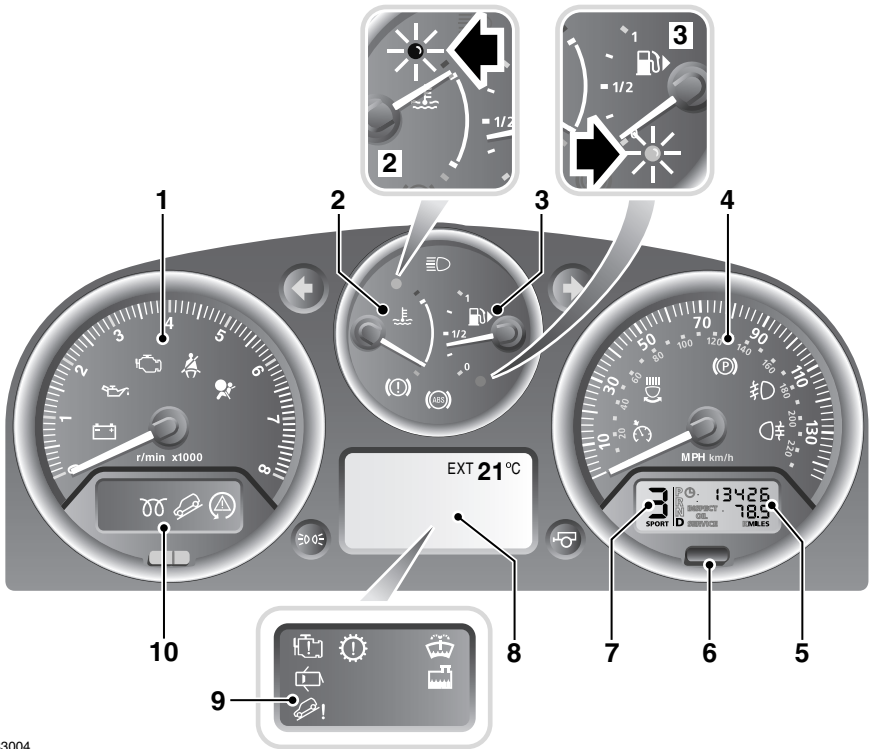

E83004

1. Tachometer.
2. Temperature gauge.
3. Fuel gauge.
4. Speedometer.
5. Odometer and trip recorder.
6. Trip recorder reset button.
7. Gear selector mode and position display.
8. Main message centre.
9. Warning indicator panel (fitted in place of main message centre).
10. Warning indicator panel.

Instruments

Tachometer

Indicates engine speed in revolutions per minute (RPM) x 1000.

Temperature gauge

CAUTION



Serious engine damage can occur if the vehicle is driven whilst the engine is overheating.

If the pointer moves onto the red line and the red warning indicator illuminates severe engine damage can occur.

If the engine overheats, stop the vehicle as soon as safety permits. Switch the engine off and allow it to cool down. If the problem reoccurs, seek qualified assistance before continuing.

***Note:** If engine temperature rises to the point where overheating may occur, there may be a noticeable reduction in engine power, and the air conditioning may cease operation. This is a normal operating strategy to reduce load on the engine and assist with cooling.*

Fuel gauge

CAUTION



Never allow the vehicle to run out of fuel. The resulting mis-fire may cause serious damage to the catalytic convertor.

Once the fuel level has dropped to the point where the range is approximately 80 km (50 miles) the low fuel warning indicator will illuminate.

As a reminder for the location of the fuel filler, there is an arrow next to the fuel pump symbol which points to the relevant side of the vehicle.

Speedometer

Indicates road speed.

Odometer

Indicates the total distance which the vehicle has travelled.

Trip recorder

Indicates the distance travelled since the last reset, and can be used to measure the distance of individual journeys.

Trip recorder reset button

Resets the distance shown on the trip recorder to zero.

***Note:** Once the trip recorder has been reset to zero, the previously recorded distance will be lost.*

Gear selector mode and position display

Displays the currently selected gear on vehicle's fitted with automatic transmission.

Main message centre

Displays warning, and information messages. See **INFORMATION MESSAGES** (page 99).

Warning indicator panel (fitted in place of main message centre)

If a main message centre is not fitted, the warning indicator panel will provide system status information.

Warning indicator panel

The warning indicator panel will provide system status information.

Information displays

TRIP COMPUTER

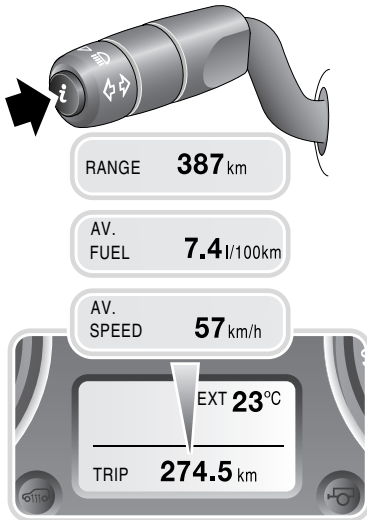

A short press (two seconds or less) or a series of short presses of the **i** button will change the trip computer display.

The options available are :-

- Approximate maximum range on current fuel.
- Average fuel consumption.
- Average speed.
- Review active warning messages.
- Blank trip computer screen (displays outside temperature).
- Trip distance.

To reset the trip distance recorder to zero, press and hold the **i** button for two seconds.

INFORMATION MESSAGES

Main message centre

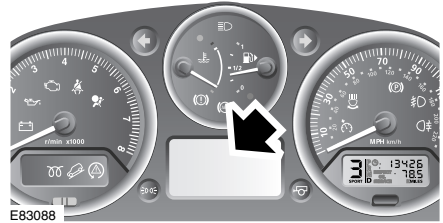

The main message centre is used to convey information, warnings, and critical warning messages to the driver.

Critical warning messages

CAUTION



Do not ignore critical warning messages, take appropriate action immediately. Failure to do so may result in serious damage to the vehicle.

Critical warning messages are accompanied by an audible warning, and the message text may have the handbook symbol next to it. These messages are displayed continuously whilst the ignition is on.

Information displays

Warnings and information messages

CAUTION



Do not ignore warning messages, take appropriate action as soon as possible.

Failure to do so may result in serious damage to the vehicle.

When displayed, warning messages are accompanied by an audible warning. These messages are displayed for approximately twenty seconds. The warning messages will be displayed when applicable, and also when the ignition is turned on, and off.

If the **i** symbol is displayed, there are current warning messages waiting to be reviewed. To review the warning messages press the **i** button repeatedly until the list of messages is displayed. The message centre will then cycle through the messages until the **i** button is pressed again.

Note: *Messages are displayed in order of importance, with critical warning messages being the highest priority.*

Messages

For information regarding the individual messages, their meanings, and any action required, please refer to the relevant section within this handbook.

Climate control

AIR VENTS

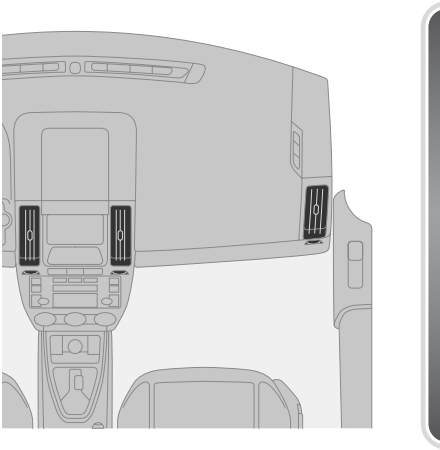

Adjust the direction and volume of air flow to suit your requirements.

Climate control

MANUAL CLIMATE CONTROL

Controls

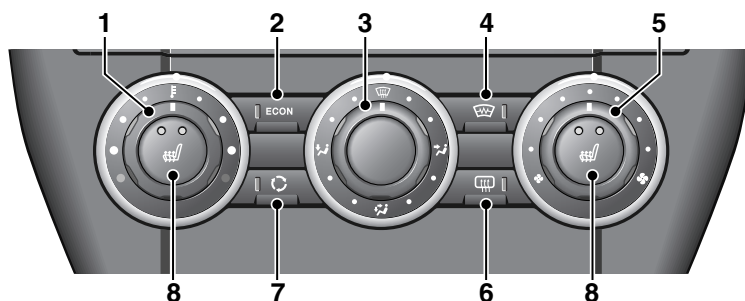

E81418

1. Temperature control, rotate to adjust.
2. Economy mode, press to switch on/off.
3. Air distribution, rotate to direct air flow.
4. Heated front screen, press to switch on/off.
5. Blower speed, rotate to change blower speed.
6. Heated rear screen, press to switch on/off.
7. Recirculation, press to switch on/off.
8. Seat heaters, press to switch on/off. Press once to turn on high, twice to turn on low, and a third time to turn off.

Note: The amber tell-tale indicators in the switches will illuminate when the function is selected.

Economy mode (2)

When selected economy mode will achieve the lowest possible temperature without using the air conditioning system. This reduces power consumption and improves fuel economy.

Air distribution (3)

Rotate the control to set the air distribution to the required points.

Note: In low temperatures it is advisable to close the centre face level vent, and direct air flow from the outer face level vents towards the side windows. This will help to keep the windows clear of ice.

Note: It is possible to distribute air to two areas simultaneously. For example; to distribute air to both the windscreen and the foot vents set the rotary control (5) to a point between the windscreen and foot vent symbols.

Recirculation (7)

When selected, the air is recirculated inside the vehicle. This helps to maintain a high or low temperature, and is useful for preventing fumes from entering the vehicle.

Note: Prolonged use at low temperatures may cause the windows to mist.

Climate control

AUTOMATIC CLIMATE CONTROL

Controls

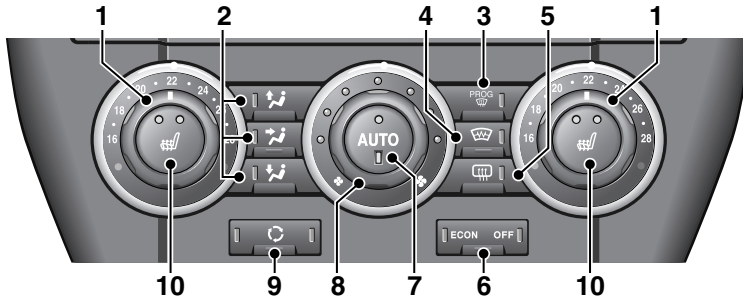

E81419

1. Left and right temperature controls, rotate to adjust.
2. Air distribution, press to select direction of air flow. More than one direction may be selected if required.
3. Defrost program, press to switch on/off.
4. Heated front screen, press to switch on/off.
5. Heated rear screen, press to switch on/off.
6. Economy mode, press to switch on/off.
7. AUTO mode, press to select fully automatic operation.
8. Blower speed, rotate to change blower speed.
9. Recirculation, press to switch on/off.
10. Seat heaters, press to switch on/off. Press once to turn on high, twice to turn on low, and a third time to turn off.

Note: The amber tell-tale lights in the switches will illuminate when the function is selected.

Air distribution (2)

Press the relevant button to set the air distribution to the required points. Screen, face, or floor. It is possible to select more than one option by pressing the required combination of buttons.

Note: In low temperatures it is advisable to close the centre face level vent, and direct air flow from the outer face level vents towards the side windows. This will help to keep the windows clear of ice.

Economy mode (6)

When selected economy mode will achieve the lowest possible temperature without using the air conditioning system. This reduces power consumption and improves fuel economy.

Climate control

Auto mode (7)

When the Auto function is selected, you have the opportunity to select a fully automatic operation, or manually adjust the fan speed and the direction of air flow. All other adjustments which are necessary to maintain the temperature that you have selected are made automatically by the climate control system.

There are two tell-tale indicators on the Auto button. The round indicator represents the blower control, and the rectangular indicator the air distribution control. In fully automatic mode both indicators illuminate, the round indicator will extinguish if the blower speed is changed manually, and the rectangular indicator extinguishes if the air distribution is changed manually.

To resume fully automatic operation at any time, press the Auto button.

Recirculation (9)

When selected, the air is recirculated inside the vehicle. This helps to maintain a high or low temperature, and is useful for preventing fumes from entering the vehicle.

A single brief press will select recirculation for four minutes. The system will then revert to fresh air intake to prevent misting.

Pressing and holding the button will select recirculation until it is switched off. This state is indicated by three flashes of the tell-tale lamp in the switch.

Note: *Prolonged use at low temperatures may cause the windows to mist.*

HEATED WINDOWS AND MIRRORS

The heated windscreen is switched on by briefly pressing the switch (4).

Note: *The operation of the heated mirrors is fully automatic, and requires no driver intervention.*

AUXILIARY HEATER

Your vehicle may be fitted with an auxiliary heater which is powered by fuel drawn from the vehicle's tank. The heater only operates at low ambient temperatures, and is fully automatic.

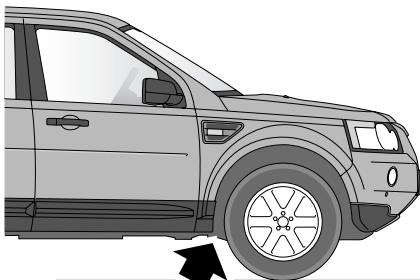

When the heater is operating exhaust fumes from the heater may be visible exiting from the front underside. This is normal, and not a cause for concern.

Climate control

ELECTRIC SUNROOF

WARNING



Extreme care must be taken to ensure that none of the occupants have any part of their body in a position where it could be trapped by the panoramic sunroof when closing. Although an anti-trap mechanism is fitted, serious injuries can occur.

Operation

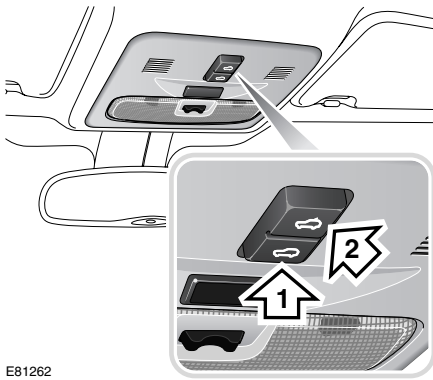

E81262

1. Front switch, closes or tilts the sunroof.
2. Rear switch, fully opens or closes the sunroof.

The panoramic sunroof can only be operated with the ignition on.

Tilt

With the roof closed, press and release the front of the switch. The sunroof will move to the tilted position automatically. It can be stopped at any point by pressing the button again.

Fully open

With the sunroof closed, press and release the rear of the switch. The sunroof will move to the fully open position automatically. It can be stopped at any point by pressing the button again.

Close

- From the fully open position, press and release the front of the switch. The roof will return to the closed position automatically.
- From the tilted position, press and hold the rear of the switch. Keep the switch pressed until the roof is fully closed.

Anti-trap mechanism

WARNING



The anti-trap mechanism does not operate when closing the roof from the tilted position. The sunroof can cause serious injury should a body part become trapped. Always ensure that the sunroof is free from obstructions before closing.

If the sunroof encounters resistance when closing it will stop, and then open slightly. This is to prevent serious injury or damage to the mechanism.

Override

CAUTION



Whenever possible remove any snow, ice, dirt, leaves etc. from the sunroof mechanism before closing. Failure to do so may damage the sunroof mechanism.

The anti-trap mechanism can be overridden to allow the roof to be closed when movement is restricted by dirt or ice. To override the anti-trap mechanism, press and hold the front of the switch until the roof reaches the closed position.

Climate control

Calibration

If the battery is disconnected, or the power supply is interrupted, whilst the sunroof is partially open it will need to be recalibrated.

Once the battery is reconnected, or the power supply is restored, recalibrate the sunroof as follows :-

1. Switch the ignition on.
2. Press the front of the sunroof switch, and hold for twenty seconds.
3. After twenty seconds the sunroof will begin to move. Keep the front of the switch pressed until the sunroof has fully opened, then closed.
4. Once the open/close cycle has completed and the sunroof has stopped moving, release the switch.

The sunroof can now be operated as normal.

Sunroof blinds

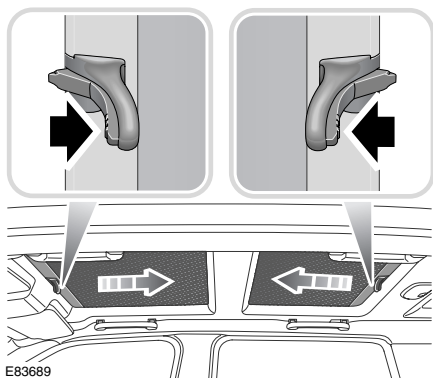

When opening the sunroof blinds, hold the catch firmly, then press the catch release button and allow the sunroof blind to open smoothly.

Convenience features

SUN VISORS

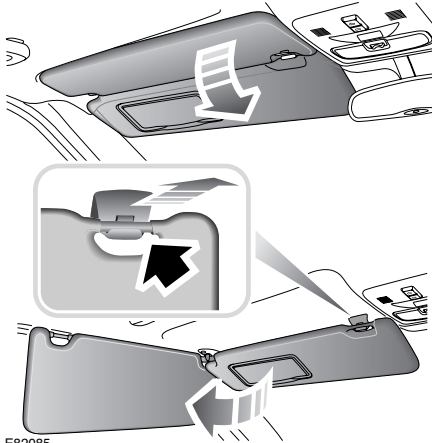

E82085

CLOCK

The clock is set through the audio system.

Setting the clock - Premium audio

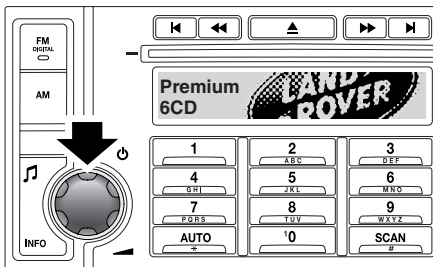

E82914

1. Switch on the audio system, by pressing the volume rotary control.

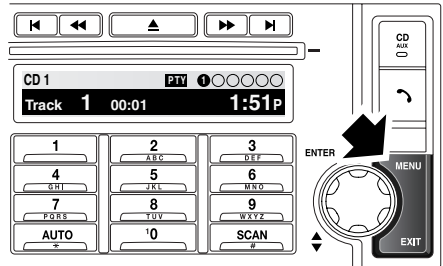

E82981

2. Press the **MENU** button to access the function menu.

Convenience features

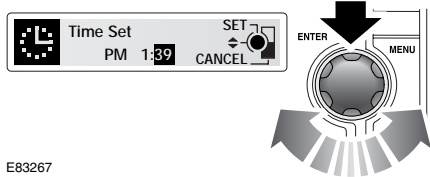
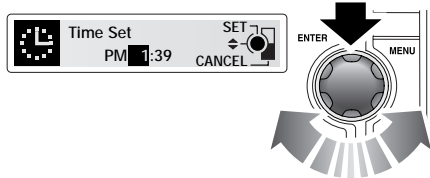
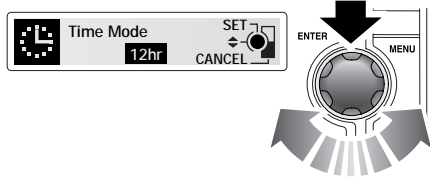
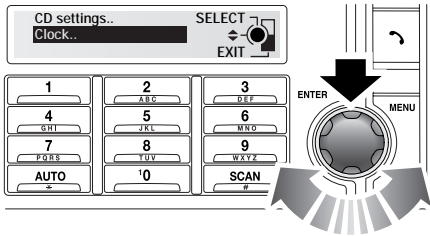

3. Rotate the control to select **Clock** and press to confirm selection.
4. Use the rotary control to adjust the **Time Mode** (12 or 24 hr), press to confirm selection.
5. Use the rotary control to adjust the **hour** displayed, press to confirm selection.
6. Use the rotary control to adjust the **minutes** displayed, press to confirm selection.
7. Press the **EXIT** button to cancel and to return to the menu.

E83267

Setting the clock - Standard audio

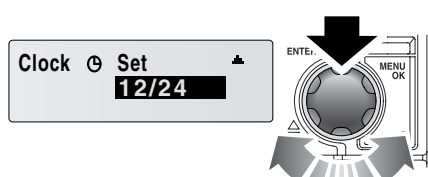
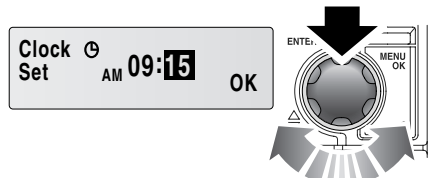
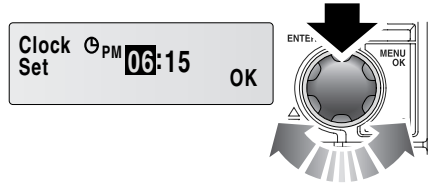
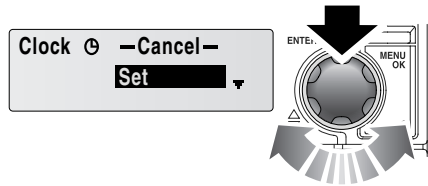

E83965

1. Switch on the audio system, by pressing the volume rotary control.
2. Press the **MENU** button to access the function menu.
3. Rotate the control to select **Clock** and press to confirm selection.
4. Rotate the control to select **Set** and press to confirm selection.
5. Use the rotary control to adjust the **hour** and press to confirm selection.

Convenience features

6. Use the rotary control to adjust the **minutes** and press to confirm selection.
7. Once the time has been set, **OK** will be highlighted. Press the rotary control to accept the settings.

Set 12/24 hour display

1. With the audio unit switched on, press the **MENU** button to access the function menu.
2. Rotate the control to select **Clock** and press to confirm selection.
3. Rotate the control to select **12/24** and press to confirm selection.
4. Use the rotary control to select **12hr** or **24hr** and press to confirm selection.

CIGAR LIGHTER

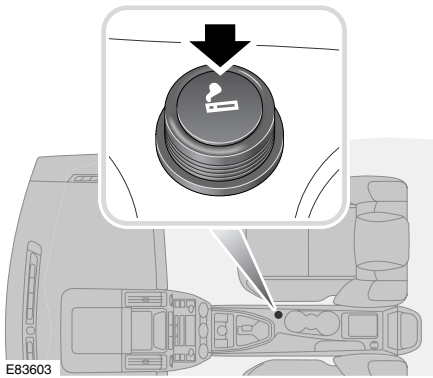

With the ignition on, and/or the engine running, press in the centre of the cigar lighter. When the cigar lighter element has reached the correct temperature it will partially eject and can be withdrawn for use.

After use push the lighter back into the first position.

ASHTRAY

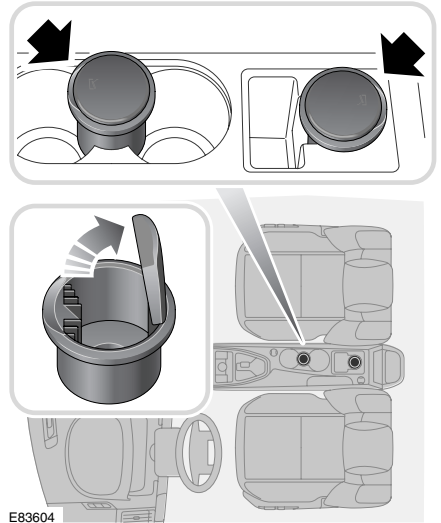

WARNING



Do not use the ashtrays for disposing of waste paper, or other combustible items. The resulting fire may cause death or serious injury.

To empty the ashtrays fully open the lid, then pull the ashtray upwards to remove.

Convenience features

AUXILIARY POWER SOCKETS

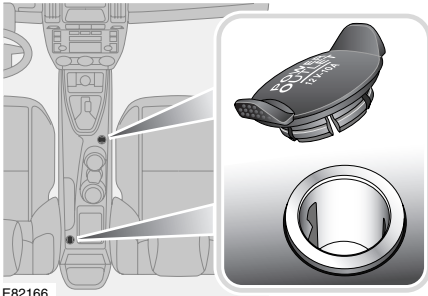

E82166

CAUTIONS

- ⚠ Only Land Rover approved accessories should be plugged into the power sockets. Using any other equipment may damage the vehicle's electrical system. If you are in any doubt contact a Land Rover Dealer/Authorised Repairer.
 - ⚠ The engine should be running when using accessories for long periods. Failure to do so can discharge the battery.
-

Convenience features

CUP HOLDERS

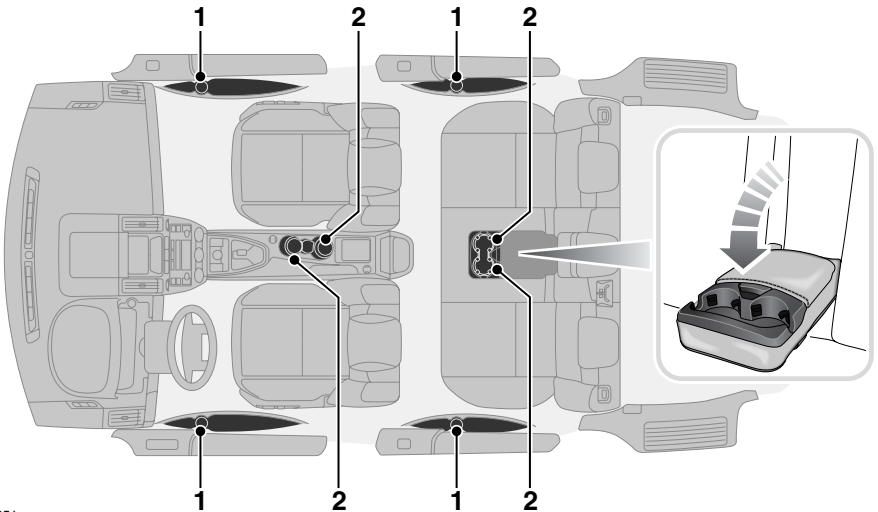



E82051

1. Bottle holders.
2. Cup holders.

WARNINGS

 The cup and bottle holders should only be used for soft containers. Containers which are hard (cans, metal, ceramic, hard plastic etc.) can cause serious injury if the vehicle is involved in an accident, sudden manoeuvre or braking.

 Do not carry open drinks containers. Hot liquids can cause serious injury when spilled and may damage the vehicle.

 Do not drink, or use the drinks holders when driving. Doing so would break concentration, which may result in loss of control.

Convenience features

STORAGE COMPARTMENTS

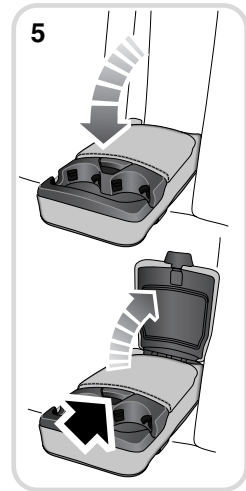
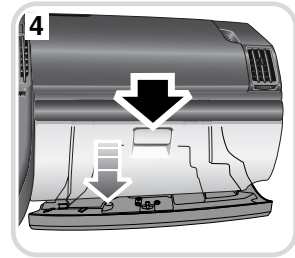
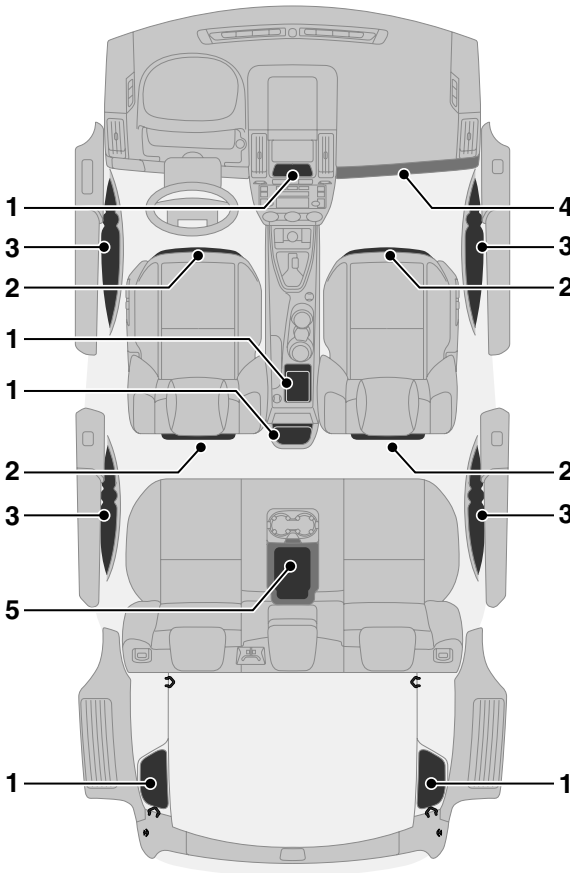

E82050

1. Coin/trinket trays.
2. Map pockets.
3. Storage compartments.
4. Glove box.
5. Rear armrest storage compartment.

WARNING



Ensure that any items stored in the vehicle are secure and cannot move. If the vehicle is involved in an accident, or subject to sudden braking or direction change, loose items can cause serious injury.

Starting the engine

GENERAL INFORMATION

Docking the remote

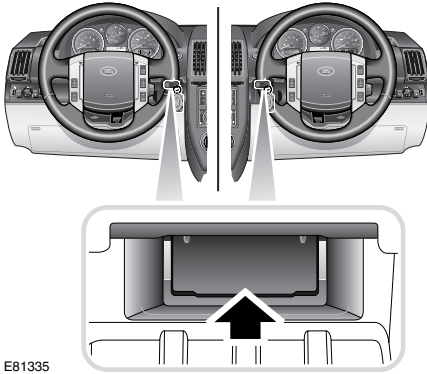

E81335

Before the engine can be started, the remote control will need to be docked.

Start/Stop button

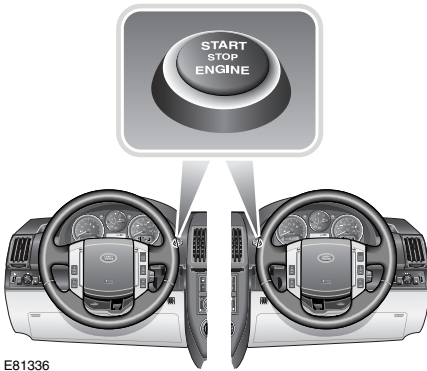

E81336

The start/stop button is used to start or stop the engine, or to turn on the ignition without starting the engine.

Switching on the ignition

To turn on the ignition without starting the engine press the start/stop button and hold until the warning indicators illuminate, then release the button.

Starting the engine

STARTING A PETROL ENGINE

Starting

WARNING



Never start the engine, or leave it running, when the vehicle is in an enclosed space. Exhaust gasses are poisonous and can cause unconsciousness and death if inhaled.

CAUTION



If the engine fails to start, do not continue cranking as this will discharge the battery. It may also damage the catalytic converter due to unburnt fuel passing through the exhaust.

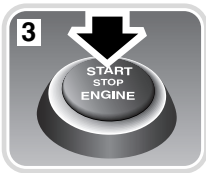
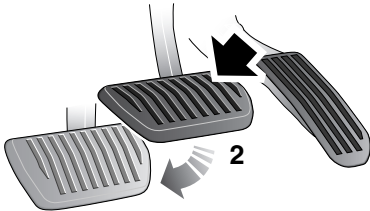
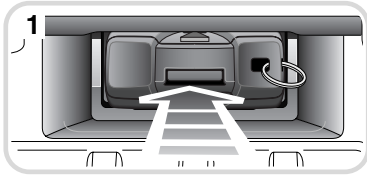

E81332

1. Insert the remote control into the docking port and press to latch.
2. Press the brake pedal.

3. With the brake pedal depressed briefly press and release the start button. The engine will crank automatically until it starts.

Stopping the engine

Before stopping the engine, ensure that the vehicle is parked safely with the park brake applied.

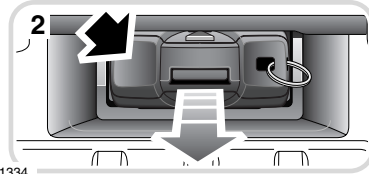
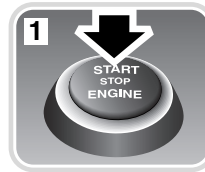

E81334

1. Select **P** (Park) and press the Start/Stop button.
2. Press the remote to unlatch it, then remove it from the docking port by gripping the sides. Do not pull the remote out using the keyring attachment as this may remove only the emergency key.

Note: **P** (Park) must be selected before the remote can be removed.

Starting the engine

STARTING A DIESEL ENGINE

WARNING



Never start the engine, or leave it running, when the vehicle is in an enclosed space. Exhaust gasses are poisonous and can cause unconsciousness and illness if inhaled.

CAUTION



If the engine fails to start, do not continue cranking as this will discharge the battery.

Manual transmission

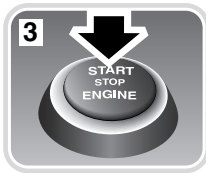
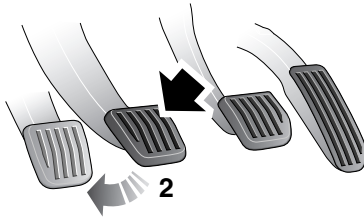
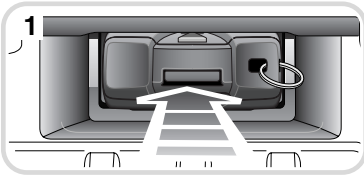

E81333

Note: Do not press the accelerator pedal when starting the engine.

1. Insert the remote control into the docking port and press to latch.
2. Press the clutch pedal.

3. With the clutch pedal depressed briefly press and release the start button. There will be a brief delay whilst the glow plugs warm up, then the engine will crank automatically until it starts.

Automatic transmission

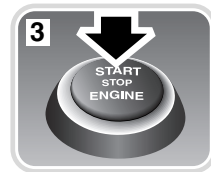
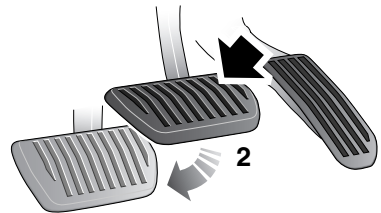
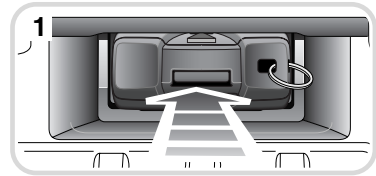

E81332

Note: Do not press the accelerator pedal when starting the engine.

1. Insert the remote control into the docking port and press to latch.
2. Press the brake pedal.
3. With the brake pedal depressed briefly press and release the start button. There will be a brief delay whilst the glow plugs warm up, then the engine will crank automatically until it starts.

Starting the engine

Stopping the engine

Before stopping the engine, ensure that the vehicle is parked safely with the park brake applied.

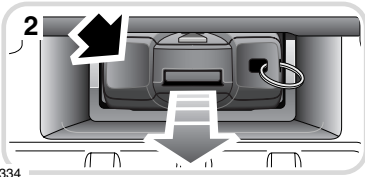
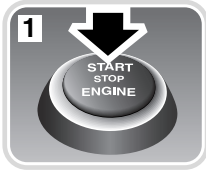

E81334

1. Select **P** (Park) and press the Start/Stop button.
2. Press the remote to unlatch it, then remove it from the docking port by gripping the sides. Do not pull the remote out using the keyring attachment as this will only remove the emergency key.

DIESEL PARTICULATE FILTER (DPF)

The Diesel Particulate Filter (DPF) forms part of the emissions reduction system fitted to Land Rover vehicles. The DPF will remove a high proportion of the harmful carbon microspheres (soot) before they leave the exhaust. It achieves this by filtering out the particles, which are then stored until they are burnt away and the filter is emptied.

Regeneration

CAUTION



The regeneration procedure produces high temperatures in the DPF. Heat can be felt radiating from beneath the vehicle, which is normal and not a cause for concern. However, the vehicle should not be parked over combustible material, particularly during dry weather. The heat generated could be sufficient to start a fire when in close proximity to combustible material such as long dry grass, paper etc.

Unlike a normal filter which requires periodic replacement, the DPF has been designed to regenerate, or clean itself to maintain operating efficiency. The regeneration process takes place automatically in most cases. However, some unfavourable driving conditions mean that the regeneration process must be initiated deliberately by the driver.

Starting the engine

Regeneration procedure

If **DPF FULL** along with the handbook symbol appears in the message centre, carry out the following procedure.

***Note:** At all times during this procedure you should observe all relevant speed limits, laws, and regulations. Always take account of traffic and weather conditions, and drive with consideration for other road users.*

1. Drive the vehicle until the engine reaches normal operating temperature. The engine should not be left idling to achieve working temperature.
2. Drive the vehicle for a further twenty minutes, keeping the road speed above 48 km/h (30 mph).
3. If regeneration is successful the warning light, or message, will extinguish. If they do not repeat the process.

***Note:** If the warning indicator or message fails to extinguish after following the regeneration process three times, contact your Land Rover Dealer/Authorised Repairer for assistance.*

Warning indicators and messages

CAUTION



Failure to take the appropriate action when a warning indicator or message appears may result in damage to the engine, DPF system, increased vehicle emissions, and costly repairs.

If regeneration cannot be achieved automatically by the system, due to short journeys for example, the driver will be notified via a warning indicator, or message.

DPF FULL

If this message appears the driver should carry out the DPF regeneration procedure as soon as possible.

DPF FULL VISIT DEALER

If this message appears the vehicle should be taken to your Land Rover Dealer/Authorised Repairer as soon as possible.

Brakes

PRINCIPLE OF OPERATION

WARNINGS



Do not rest your foot on the brake pedal whilst the vehicle is in motion. This may cause a light application of the brakes, which can result in overheating, reduced brake performance, and excessive brake wear.



Never allow the vehicle to coast (freewheel) with the engine turned off. The engine must be running to provide full braking assistance. The brakes will still function with the engine off, but far more pressure will be required to operate them.



If the red brake warning indicator illuminates, safely bring the vehicle to a stop, as quickly as possible. Seek qualified assistance before proceeding.



Never place non-approved floor matting or any other obstructions under the brake pedal. This restricts pedal travel and braking efficiency.

Brake pads

Brake pads require a period of bedding in when new. Drive with extra caution for the first 800 km (500 miles) to avoid then need for heavy braking.

Wet conditions

Driving through heavy rain or water can have an adverse effect on braking efficiency. Under those circumstances it is recommended that you lightly apply the brakes intermittently to dry the brakes.

HINTS ON DRIVING WITH ABS

WARNINGS



ABS cannot overcome the physical limitations of braking distance. Nor can it overcome the lack of grip on a road surface, aquaplaning on water for example.



Braking distance is increased on a slippery surface. This applies to all vehicles, even those fitted with ABS.



The driver should not be tempted to take risks when driving, in the hope that ABS will correct errors of judgement. In all cases it remains the driver's responsibility to drive with due care and attention, paying particular attention to the effects of speed, weather, road conditions etc.

ABS (Anti-Lock Braking System) allows maximum brake pressure, and thus maximum braking efficiency, to be applied, and prevents the road wheels locking. This allows the driver to retain steering control during heavy braking under most road conditions.

During emergency braking conditions ABS constantly monitors the speed of each wheel. ABS varies the brake pressure to individual wheels, according to the grip available. The constant alteration of brake pressure can be felt as a pulsing sensation through the brake pedal. This is not a cause for concern, as it is designed to demonstrate to the driver that ABS is operating.

ABS warning indicator



If this amber warning indicator illuminates, drive with extra caution, avoid heavy braking where possible, and seek qualified assistance as soon as possible.

Brakes

ABS and off-road driving

ABS will operate when driving off-road, however it may be unwise to rely on it's assistance under some conditions.

Stopping distances will be increased when travelling over rough, or bumpy terrain.

Soft surfaces

On soft or deep surfaces such as powdery snow, sand, or gravel, the braking distance required will be increased. This is because the natural action of a locked wheel (which cannot happen when ABS is operating) is to form a wedge of surface material in front of the wheel, which reduces the stopping distance.

Steep slopes

If the vehicle is stationary on a steep, slippery slope, it may begin to slide even with the brakes applied. This is because without wheel rotation the ABS cannot determine vehicle movement.

To counteract this, briefly release the brakes to allow some wheel rotation. Then re-apply the brakes to allow ABS to gain control.

Emergency Brake Assist (EBA)

If the driver rapidly applies the brakes, EBA automatically boosts the braking force to it's maximum in order to bring the vehicle to a halt as quickly as possible. If the driver applies the brakes slowly, but conditions mean that ABS operates on the front wheels, EBA will increase the braking force in order to apply ABS control to the rear wheels.

EBA stops operating as soon as the brake pedal is released.



A fault with the EBA system is indicated by the red brake warning indicator illuminating.

Electronic Brake Distribution (EBD)

EBD controls the balance of braking forces supplied to the front and rear wheels, in order to maintain maximum braking efficiency.

If the vehicle has a light load (only the driver in the vehicle for example) the EBD will reduce the braking force applied to the rear wheels. If the vehicle is heavily laden then EBD will increase the braking force to the rear wheels.



A fault with the EBD system is indicated by the red brake warning indicator illuminating.

PARKING BRAKE

Parking on a slope

Facing uphill

If the vehicle is parked facing uphill, select first gear (manual gearbox), or Park (automatic gearbox), and turn the steering wheel so that the front wheels face away from the kerb.

Facing downhill

If the vehicle is parked facing downhill, select reverse gear (manual gearbox), or Park (automatic gearbox), and turn the steering wheel so that the front wheels face towards the kerb.

Brakes

Applying the parking brake

WARNING



Ensure that the parking brake is applied fully before releasing the parking brake lever.

Note: The front seat armrest may obstruct the operation of the parking brake for some drivers. If this is the case, lift the seat armrest before applying the parking brake.

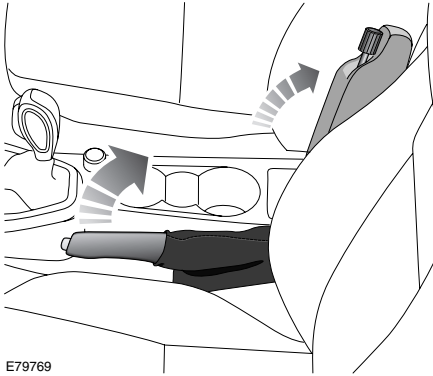

1. Firmly apply the foot brake.
2. Pull the parking brake lever upwards until the parking brake is applied.



When the parking brake is applied the warning indicator will illuminate.

Note: Do not press the parking brake release button when applying the parking brake.

Releasing the parking brake

WARNING



Ensure that the foot brake is applied before releasing the parking brake.

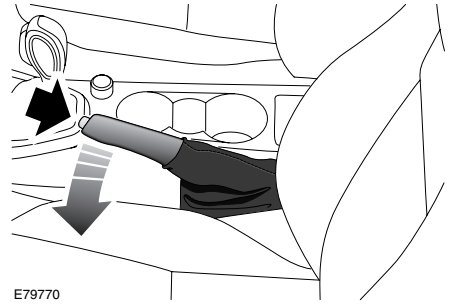

1. Firmly apply the foot brake.
2. Press the parking brake lever release button.
3. With the button pressed, lower the parking brake lever to its lowest position.



When the parking brake is released the warning indicator will extinguish.

Parking aid

PRINCIPLE OF OPERATION

Park Distance Control (PDC) provides the driver with information on most obstructions, and their distance from the vehicle, when manoeuvring. PDC does this by using four ultrasonic sensors on each bumper.

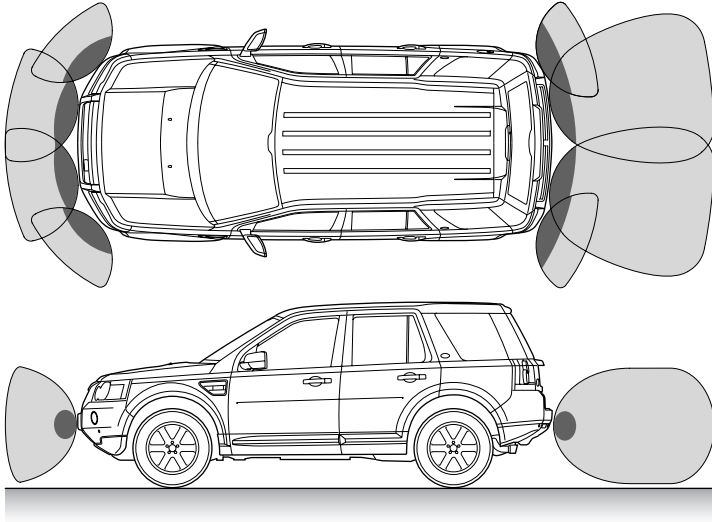

E79871

1. When objects are detected at this range the PDC will emit a pulse tone which increases in frequency as the vehicle gets closer to the object.
2. When objects are sensed within this range, approximately 30 centimetres (12 inches) the tone becomes continuous.

Parking aid

USING THE PARKING AID

WARNING



Parking aids may not detect moving objects such as children and animals until they are dangerously close.

Always use extreme caution when manoeuvring.

CAUTIONS



Parking aids are for guidance only, and are not intended to replace the driver's visual checks for obstructions when manoeuvring.



PDC sensors may not detect some obstructions. Obstructions such as narrow posts, small objects close to the ground, and some objects with dark non-reflective surfaces for example.



Systems which use the same frequency band as the front PDC sensors may cause irregular tones to be emitted.

PDC activation



Front PDC is activated by pressing the PDC button a short confirmation tone will be heard, and the tell-tale will illuminate. The front sensors will remain active as long as the vehicle's speed does not exceed 16 km/h (10 mph).

If reverse gear is selected, front and rear sensors are activated.

In vehicles fitted with automatic transmission, selecting neutral from reverse will keep front and rear sensors active.

Front PDC deactivation

The PDC system can be deactivated by pressing the PDC switch.

Towing

The rear sensors are automatically disabled when a trailer is connected.

Sensor care

CAUTION



When washing the vehicle do not aim high pressure water jets directly at the sensors. Do not use abrasive materials or hard/sharp objects to clean the sensors. Only use approved vehicle shampoo.

The sensors should be kept clean to maintain accuracy and performance.

System fault

If a system fault is detected, a long high-pitched tone will sound, and the switch indicator lamp will flash. Contact your Land Rover Dealer/Authorised Repairer as soon as possible.

Transmission

MANUAL TRANSMISSION

CAUTION

⚠ Selection of reverse gear is prevented when the vehicle is travelling in excess of 24 km/h (15 mph). Never attempt to engage reverse gear whilst the vehicle is in forward motion. This may result in serious transmission damage and costly repairs.

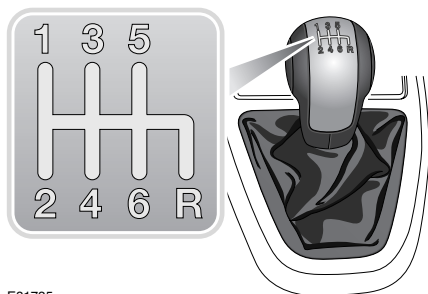

E81735

The gear lever is spring loaded, and when in neutral sits between third and fourth gear positions. Extra pressure will be required to move across to reverse.

AUTOMATIC TRANSMISSION

WARNING

⚠ Park (P) should be engaged when the vehicle is stationary. The vehicle can move unexpectedly with any other gear position selected, which may result in death or serious injuries to people or animals outside of the vehicle.

CAUTIONS

- ⚠ Never select the Park (P) position whilst the vehicle is in motion. Doing so may cause serious damage to the transmission.
- ⚠ Never select the Reverse (R) position whilst the vehicle is in forward motion. Doing so may cause serious damage to the transmission.
- ⚠ Never select a forward gear whilst the vehicle is in rearward motion. Doing so may cause serious damage to the transmission.
- ⚠ Do not rev the engine or allow it to run above normal idle speed while selecting D or R, or while the vehicle is stationary with any gear selected.
- ⚠ Do not allow the vehicle to remain stationary for any length of time with a gear selected and the engine running. Always select P or N if the engine is to idle for a prolonged period.

Transmission

Automatic mode

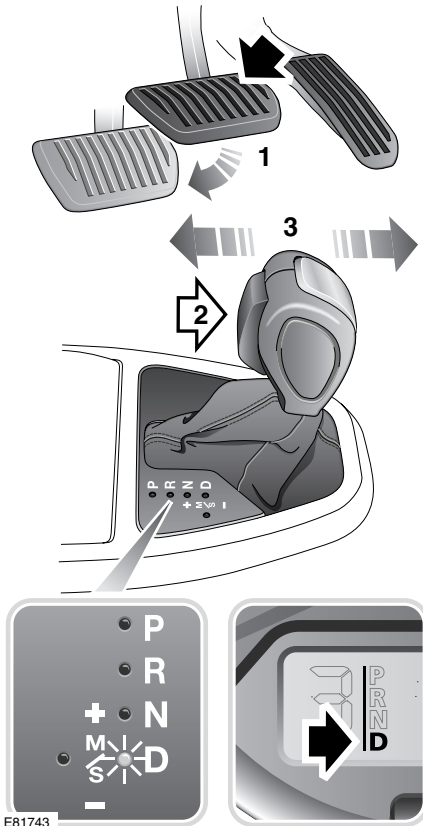

Note: If pressure is applied to the selector lever before the foot brake is applied, any gear selected may not be available irrespective of the lever position. In this situation, remove pressure from the selector lever, ensure that the footbrake is applied and select the required gear.

Note: When a gear is selected the vehicle may begin to move as soon as the foot brake is released.

Kick-down

When D is selected, and the accelerator pedal is depressed fully the transmission will downshift to the lowest appropriate gear. Once the accelerator pedal is returned to a normal driving position the transmission will upshift to the highest appropriate gear.

Note: Kick-down operation will vary according to road speed, current gear in use and accelerator movement.

To select Drive (D) when the vehicle is stationary :-

1. Apply the footbrake.
2. Press the gear selector release button.
3. Move the gear selector to Drive (D).

When in D the transmission will automatically select the most appropriate gear for the current driving conditions.

Transmission

Sport mode and CommandShift™

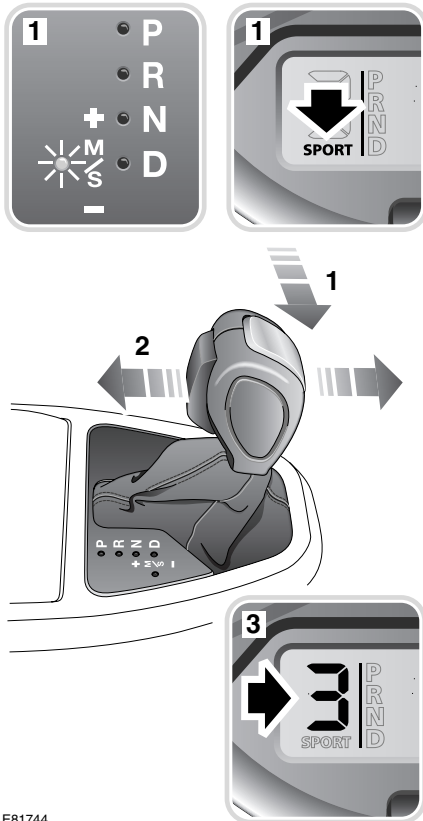

E81744

1. To select sport mode, move the selector lever from **D** to **SPORT**.
2. To use CommandShift, move the selector lever forward to move up a gear, and back to move down a gear.

Sport mode

When sport mode is selected (1) **SPORT** will be displayed in the message centre, and the selector indicator will illuminate.

To return to automatic mode move the selector lever back to the Drive (D) position. The **D** on the selector display will illuminate to confirm that automatic mode has been selected.

CommandShift™

When using CommandShift the selected gear is displayed in the message centre (3).

Moving away from a stand still can be achieved using either first or second gear. This may prove useful for certain terrain, using second gear for pulling away on snow for example.

Note: In order to protect the engine, the transmission will automatically change up to prevent over-revving, or down if the engine is labouring.

Note: When in CommandShift, if the vehicle comes to a complete stop the transmission will remain in second gear. First gear can be selected manually if required.

Electronic gear change strategies

In automatic, or sport modes (not available in CommandShift) the gear change points will be adapted to suit driving conditions.

Hill ascent, towing, and high altitude

The lower gears are selected, and maintained for longer than usual. This helps overcome the loss of momentum when towing, or ascending hills. It also helps overcome the loss of engine torque when the vehicle is operating at high altitudes.

Hill descent

With HDC selected in either automatic, or sport modes, a low gear will be selected and maintained to provide maximum engine braking.

Transmission

High temperatures

In circumstances where engine and transmission temperatures are raised to very high levels, the gear change strategy will alter to provide maximum cooling efficiency.

Transmission fault

In the unlikely event that a fault develops within the transmission system, **F** will be displayed in the gear position display and a warning message will appear in the message centre. A limited range of gears will be available, and you should seek qualified assistance immediately.

Transmission

TECHNICAL SPECIFICATIONS

Transmission fluids and capacities

Transmission unit	Fluid specification	Fluid capacity
Automatic gearbox	Esso JWS3309	7 litres (12.3 pints)
Manual gearbox	Castrol MTF 97309	1.9 litres (3.3 pints)
Power transfer unit	Castrol BOT118	0.75 litres (1.3 pints)
Haldex coupling	STAT OIL SL01-301	0.65 litres (1.1 pints)
Rear differential	Castrol EPX	0.7 litres (1.2 pints)

Cruise control

PRINCIPLE OF OPERATION

Cruise control enables the driver to maintain a constant road speed without using the accelerator pedal. This is particularly useful for motorway cruising, or for any journey where a constant speed can be maintained for a lengthy period.

USING CRUISE CONTROL

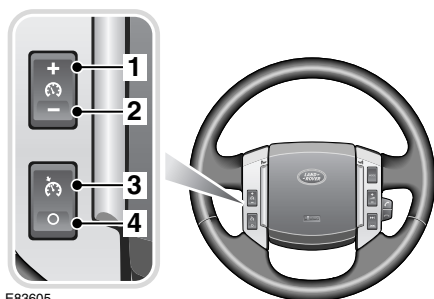

1. Set target speed, or increase speed.
2. Decrease speed.
3. Resume set speed.
4. Cancels cruise control operation without erasing memorised speed.

Note: Cruise control is not available in HDC, or when a Terrain Response special program has been selected.

Note: Do not use cruise control in traffic conditions where a constant speed cannot easily be maintained.

Note: Do not use cruise control on winding roads, or in slippery conditions.

Note: Do not use cruise control when driving off-road.

Note: Do not use cruise control with **SPORT** mode selected.

Engaging cruise control

Note: Cruise control can only be engaged at speeds in excess of 30 km/h (18 mph).

Accelerate until the desired speed is reached, then press the + switch to set the vehicle speed into the system's memory. Cruise control will now maintain that speed.



The cruise control warning indicator will illuminate to confirm cruise control is operational. Speed can be increased using the accelerator pedal as normal, to overtake for example. As soon as the accelerator pedal is released, the vehicle speed will return to the set cruising speed.

Note: If the accelerator pedal is pressed for more than 60 seconds, cruise control will be cancelled.

Suspending cruise control

Cruise control can be suspended by a single press of the cancel switch. The warning indicator will extinguish when cruise control is cancelled.

Cruise control will also be suspended if the brake pedal is pressed, the gear selector is moved to N, or if HDC or DSC are activated.

To resume cruise control operation at the previously set speed, press the resume switch.

Note: The set speed will not be erased by pressing the cancel switch. The set speed can only be erased by switching off the ignition.

Reducing the cruise speed

To reduce cruising speed, press and hold the — switch. Release the switch when the desired speed is reached, the new speed will be set and maintained.

The set speed can be reduced incrementally by tapping the — switch. Each press of the switch will decrease the speed by 1 km/h or 1 mph depending on which scale is in use.

Cruise control

Increasing the cruise speed

CAUTION



When setting the cruise control to the speed limit it is important to remember that it is possible for the vehicle speed to increase when travelling downhill. This may result in the vehicle speed exceeding the speed limit.

Press and hold the + switch to increase speed. Release the switch when the desired speed is reached, the new speed will be set and maintained.

The speed can be increased incrementally by tapping the + switch. Each press of the switch will increase the speed by 2 km/h (1 mph).

Speed can also be increased using the accelerator. When the desired speed is reached press the + switch to set and maintain the new speed.

Hill descent control (HDC)

PRINCIPLE OF OPERATION

HDC operates in conjunction with ABS to provide greater control when off-road, particularly when descending steep slopes. HDC operation is fully automatic when engaged.

During a hill descent when driving off-road, engine braking is used to control the speed of descent. If engine braking alone is insufficient to control the vehicle's speed, HDC will slow the vehicle using the braking system. HDC will control the descent speed relative to the gear selected and accelerator position.

If the vehicle is fitted with a manual transmission, HDC should only be used in first, or reverse gears. If the vehicle is fitted with an automatic transmission, HDC should only be used in **D**, **R**, or CommandShift **1**. When in **D** the vehicle will select the most appropriate gear.

***Note:** HDC is automatically selected by some of the Terrain response special programs.*

Gradient release control (GRC)

With HDC activated, if the vehicle is stopped on a slope using the footbrake, GRC will become active. When the footbrake is released GRC will automatically delay the brake release to allow take up of drive, and build up of engine torque. The brakes will then gradually release to allow the vehicle to move smoothly away under the control of HDC.

GRC operates in forward and reverse, and requires no driver intervention.

Before driving off-road

Before venturing off-road it is absolutely essential that inexperienced drivers become fully familiar with the vehicle's controls. In particular, CommandShift, Hill Descent Control (HDC), and the Terrain Response system.

Basic information and off-road driving techniques can be found in the off-road driving handbook available on-line at

<http://www.ownerinfo.landrover.com>

Off-road driver training should be undertaken by anyone intending to drive off-road. Training is available at your nearest Land Rover Experience centre. More details can be found at

<http://www.landroverexperience.com>

Hill descent control (HDC)

USING HDC

Selecting HDC

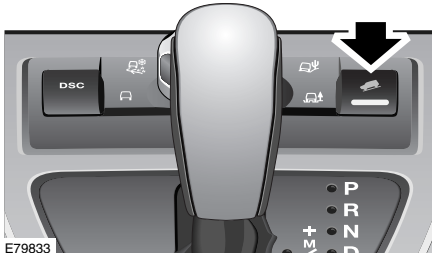
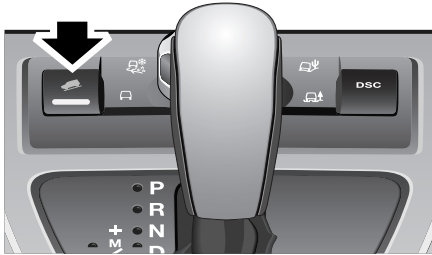

E79833

HDC can be selected at speeds below 80 km/h (50 mph). To select HDC, press and release the HDC on/off switch.



The green HDC indicator will illuminate continuously at speeds below 50 km/h (30 mph) to indicate that HDC is fully active.

If the vehicle speed exceeds 80 km/h (50 mph) HDC will disengage, and the HDC indicator will extinguish.

If HDC has been selected, and the vehicle speed rises above 50 km/h (30 mph) HDC is suspended, and the HDC indicator will flash. A message will appear in the message centre to confirm the suspension of HDC.

HDC operation

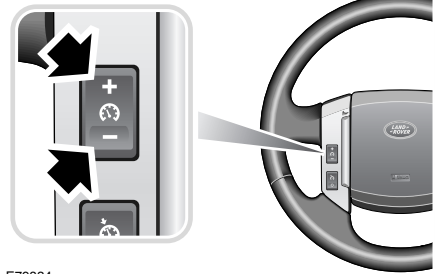

E79834

With HDC engaged, the speed of descent can be altered using the cruise control steering wheel switches. + increases the speed, and — decreases the speed.

To increase speed press, and hold, the + switch until the desired speed is achieved. When the switch is released, the speed will be maintained.

To decrease speed press, and hold, the — switch until the desired speed is achieved. When the switch is released, the speed will be maintained.

To increase or decrease speed gradually, tap the + or — switch as required. Each tap of the switch will increase, or decrease the speed in increments of 0.5 km/h (0.3 mph). The accelerator pedal can also be used to increase speed, up to the threshold in each gear.

Note: Each gear has a pre-determined minimum speed.

Descent speed will only increase on a slope steep enough to provide additional momentum. Therefore, use of the + switch on a gentle slope may not increase the speed.

When using HDC in vehicles fitted with a manual transmission, depressing the clutch pedal will prevent HDC from controlling the speed of descent.

Hill descent control (HDC)

If the brake pedal is depressed, HDC will be overridden and the brakes will operate as normal. When the brake pedal is released, HDC will resume control of the descent.

If HDC is switched off during a descent, HDC assistance will fade out gradually. This is to prevent loss of control if HDC is switched off in error. HDC will resume control when switched back on if assistance is still required, but at the speed the vehicle is travelling when the pedal is released.

When driving off-road HDC can be permanently selected, but it will only provide assistance when the speed parameters are met.

Warning messages

WARNING



Do not attempt a steep descent if HDC is inoperative, or warning messages are displayed.

Brake temperature

In extreme circumstances, the HDC system may cause brake temperatures to exceed their pre-set limits. If this occurs the warning message **HDC TEMPORARILY NOT AVAILABLE SYSTEM COOLING** will be displayed in the message centre. HDC will then fade out and become temporarily inactive.

If the vehicle is not fitted with a message centre, then the amber HDC warning indicator will flash.

HDC will remain unavailable until the brakes reach an acceptable temperature. Once the brakes have reached an acceptable temperature, the message will disappear (or the warning indicator will extinguish) and HDC will, if required, resume operation.

System fault

If a fault is detected in the HDC system, **HDC FAULT SYSTEM NOT AVAILABLE** will appear in the message centre.

If the vehicle is not fitted with a message centre the amber HDC warning indicator will illuminate.

If the fault is detected whilst the system is operating HDC assistance will fade out.

If a fault is detected, contact your Land Rover Dealer/Authorised Repairer as soon as possible.

Terrain response

PRINCIPLE OF OPERATION

The Terrain Response System provides an opportunity for the driver to feed back terrain information to the vehicle by choosing a general setting or one of three special programs. It then uses that information to optimise the vehicle's systems for improved traction and driveability. It does this by bringing together vehicle drive control systems which usually operate individually.

The drive systems optimised by the Terrain Response System are :-

- Engine management.
- Gearbox management.
- Intelligent coupling control.
- Dynamic stability, traction and Hill Descent controls.

The system will provide a variable accelerator pedal response, ranging from very cautious for slippery conditions (where a large pedal movement has only a small effect on engine power) to very responsive (where engine power is allowed to rise more quickly).

Note: *Changing from one special program to another will introduce noticeably different responses. For example, the engine revs produced by the current accelerator pedal position, may increase or decrease in the new program.*

To familiarise yourself and get the best from the system you should try out the programs in circumstances which are safe for you and other road users.

Terrain response has been designed to benefit the driver no matter what their level of off-road driving experience. The system will aid those with less experience, and enhance the skills of those with more experience.

USING TERRAIN RESPONSE

Note: *The Terrain Response System is designed to be engaged before crossing difficult terrain. Do not wait until control has been lost before using the special programs.*

When the vehicle is started, the Terrain Response System will be in its General program. The General program will allow the vehicle to operate capably in most conditions, as some of the sub-systems will react to the conditions where appropriate. When conditions change, and more difficult conditions are encountered, the appropriate special program should be selected.

Before driving off-road

Before venturing off-road it is absolutely essential that inexperienced drivers become fully familiar with the vehicle's controls. In particular, CommandShift, Hill Descent Control (HDC), and the Terrain Response system.

Basic information and off-road driving techniques can be found in the off-road driving handbook available on-line at

<http://www.ownerinfo.landrover.com>

Off-road driver training should be undertaken by anyone intending to drive off-road. Training is available at your nearest Land Rover Experience centre. More details can be found at <http://www.landroverexperience.com>

Driver override options

All systems will be set to their optimum parameters for the conditions reflected in the choice of special program. However, if required, Hill Descent control can be operated independently. See **USING HDC** (page 137). If it has not been automatically selected by the special program, it may be engaged as required. Conversely, if it has been selected, but is not required, it may be turned off.

Terrain response

The HDC status will be displayed on the message centre whether it is engaged or disengaged by the system, or the driver. Use of HDC in special programs may prompt additional driving advice, and warnings to be displayed on the message centre.

Although Dynamic Stability Control is automatically engaged when a special program is selected, it can be turned off if required. See **USING TRACTION CONTROL** (page 139).

Automatic gear selection can be overridden by using the CommandShift function.

Terrain Response operation



A rotary control just in front of the gear lever is used to select the required special program. When the selector reaches the end of the selection range in either direction it can be rotated further, but it has no effect.

In addition to the general program, there are three special programs.

- Grass/Gravel/Snow (also used for ice).
- Mud/Ruts.
- Sand.

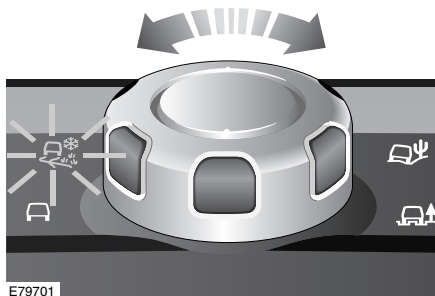

When the starter button is pressed, the indicators around the rotary control are illuminated. The active program is highlighted in amber, and the program icon is displayed in the message centre.



The special programs remain active for six hours after the ignition is turned off. If the ignition is turned on again within six hours the program will remain active. After six hours the general program is automatically selected.

General program



This program is compatible with all on and off-road conditions. If not already active, it should be selected before driving on surfaces which are similar to a hard road surface. Dry cobbles, tarmac, dry wooden planks, etc. all fall into this category.

Terrain response

This program should be selected once the need for a special program has passed. Once the special program has been deselected, all of the vehicle systems will return to their normal settings except HDC. HDC will remain active if it was selected manually.

Grass-Gravel-Snow



This program should be used where a firm surface is covered with loose, or slippery material.

Surfaces covered in water, ice, slime, grass, gravel, shale, pebbles, or a thin coating of sand for example.

Note: For deep gravel it is recommended that the Sand program is selected.

In slippery conditions, it may be beneficial to pull away in a higher gear than usual.

For information on the fitment and use of snow chains. See **USING SNOW CHAINS** (page 192).

For information on the fitment and use of winter tyres. See **USING WINTER TYRES** (page 183).

Note: If the vehicle is unable to gain traction in deep snow, switching DSC off may help. DSC should be switched on again as soon as the difficulty is overcome. See **USING TRACTION CONTROL** (page 139).

Mud-Ruts



This program should be used for crossing terrain that is muddy, rutted, soft, or uneven.

Sand



This program should be used for terrain which is predominantly soft dry sand, or deep gravel.

Note: If the vehicle is unable to gain traction in extremely soft, dry sand, switching DSC off may help. DSC should be switched on again as soon as the difficulty is overcome. See **USING TRACTION CONTROL** (page 139).

If the sand to be crossed is damp/wet, and sufficiently deep to cause the wheels to sink into the surface, the Mud-Ruts program should be used.

System difficulties

Note: Selection of an inappropriate special program will not endanger the driver, nor will it immediately damage the vehicle. However, if continued, use of an incorrect program will impair the vehicle's response to the terrain, and can reduce the durability of the drive systems.

If the system becomes partially inoperable for any reason, it may not be possible to select special programs. A warning will be given when selection of a special program is attempted. If the Terrain response system becomes totally inoperable, all of the program indicators will be switched off, and the message centre will display the relevant message.

If a participating vehicle system becomes temporarily inoperable, the General program will be automatically selected. Once the system returns to normal operation, the previously active program will be re-activated unless the ignition has been turned off in the mean time.

Terrain response messages

Messages relating to the terrain response system are displayed on the message centre. See **INFORMATION MESSAGES** (page 99).

Most of the messages that appear will be for information only, and require no driver intervention, **SAND PROGRAM SELECTED** for example.

Terrain response

Messages that require driver intervention are shown in the following table.

Message	Meaning	What to do?
PROGRAM CHANGE IN PROGRESS	Conditions exist which temporarily prevent selection of a new program.	If conditions change within 60 seconds, the chosen program will be activated. If the message is prompted by electronic coupling overheat the delay will be longer. A separate message will also be displayed.
SYSTEM FAULT SPECIAL PROGRAMS NOT AVAILABLE	A fault exists which renders the Terrain Response programs unavailable.	Use extreme caution if travelling off road, and seek qualified assistance immediately.
RECOMMEND COMMAND SHIFT FOR DEEP SOFT SAND	In extreme sand conditions, it may be beneficial to select Command Shift to improve driver control.	Select Command Shift if required.

Traction control

USING TRACTION CONTROL

Electronic Traction Control (ETC)

ETC operates in conjunction with Dynamic Stability Control (DSC) and is designed to assist when one, or more, wheels have lost traction.

If a wheel loses traction, ETC will operate the brake on that wheel until it regains traction.

Warning indicator



If a fault is detected within the ETC system the warning indicator will illuminate.

Before driving off-road

Before venturing off-road it is absolutely essential that inexperienced drivers become fully familiar with the vehicle's controls. In particular, CommandShift, Hill Descent Control (HDC), and the Terrain Response system.

Basic information and off-road driving techniques can be found in the off-road driving handbook available on-line at

<http://www.ownerinfo.landrover.com>

Off-road driver training should be undertaken by anyone intending to drive off-road. Training is available at your nearest Land Rover Experience centre. More details can be found at **<http://www.landroverexperience.com>**

Stability control

PRINCIPLE OF OPERATION

Dynamic Stability Control (DSC)

WARNING



DSC is unable to compensate for driver errors.

It is the driver's responsibility to drive with due care and attention, in a manner which is safe for their vehicle, it's occupants, and other road users.

DSC has two main functions.

Firstly, if a wheel, or wheels, lose traction when accelerating, it enhances Traction Control by reducing engine torque, and applying braking force to individual wheels. This further improves the vehicle's ability to pull away on slippery, or loose surfaces, and reduces the likelihood of wheel spin when cornering.

Secondly, DSC will apply braking force to individual wheels in order to maintain vehicle stability when cornering, changing lanes suddenly, or manoeuvring in an emergency. This will help to keep the vehicle on the driver's intended path, rather than over, or under steering.

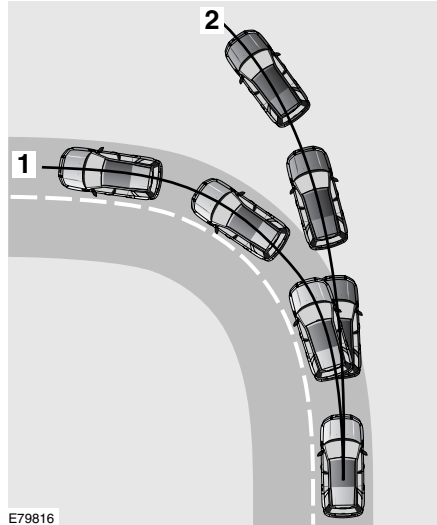

1. Vehicle fitted with DSC.
2. Vehicle without DSC.

Roll stability control (RSC)

WARNING



No electronic system can remove the need for safe driving practice. RSC can help to maintain control of the vehicle.

It cannot regain control of the vehicle if it has been lost, or overcome driver errors. Always drive with due consideration for the prevailing road and weather conditions.

RSC works in conjunction with DSC to try and prevent vehicle roll-over. If the system senses that the vehicle is approaching roll-over it will reduce engine power and use the ABS system to reduce the chance of roll-over.

Stability control

USING STABILITY CONTROL

DSC

DSC is activated automatically each time the engine is started, and is automatically selected by some of the Terrain Response Special programs.

Note: In the majority of driving situations, and particularly on-road, it is recommended that you do not turn DSC off.

Deactivating DSC

CAUTION



Driving with DSC deactivated puts additional loads on the brakes.

Wherever possible, drive with DSC activated.

In some driving conditions it may prove helpful to deactivate DSC to improve traction. These conditions include :-

- Rocking the vehicle out of a hollow.
- Rocking the vehicle out when the wheels have sunk into the surface.
- Pulling away in deep snow, or a loose surface.
- Driving along deep ruts.
- Driving through deep mud.

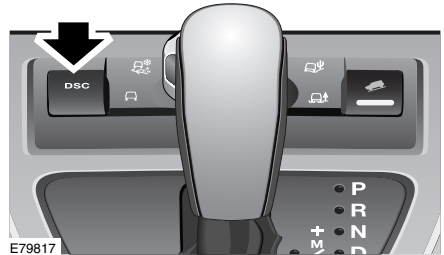
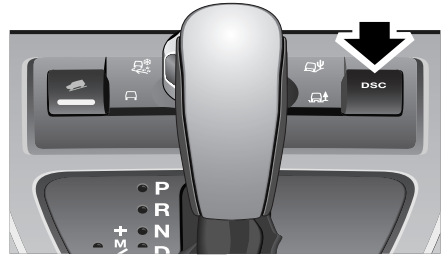

E79817



To deactivate DSC, press, and briefly hold, the DSC button. The DSC warning indicator will

illuminate continuously as a reminder that DSC is deactivated.

Note: Deactivating DSC will have no effect upon the operation of Traction Control.

Reactivating DSC

DSC is reactivated by :-

- pressing, and briefly holding the DSC button.
- starting the engine.
- selecting a new Terrain Response special program.

DSC system fault

If a fault is detected the DSC warning lamp will illuminate continuously when DSC has not been deactivated.

Fuel and refuelling

SAFETY PRECAUTIONS

WARNINGS



Petroleum gasses are highly flammable, have a low flash point, and are explosive, especially in confined spaces. Avoid exposing the gasses to any potential sources of ignition as the resulting fire and explosion may cause serious injuries and/or death.



Only use containers specifically designed for carrying fuel, and always remove them from the vehicle to fill them. Failure to do so may result in spillage, and cause a fire.



Switch off the engine when refuelling, as it is both a source of extreme temperatures, and electrical sparks.

The resulting fire and explosion may cause serious injury and death.



Switch off any personal electronic devices such as mobile phones, or music players. They have the potential to cause electrical sparks. The resulting fire and explosion may cause serious injury and death.



Do not smoke, use a naked flame, or cause sparks. The resulting fire and explosion may cause serious injury and death.



Do not overfill the fuel tank. Overfilling may cause spillage when the vehicle is driven. Spillage may also occur if the fuel expands in high ambient temperatures.

FUEL QUALITY

Petrol engined vehicles

CAUTIONS



Do not use leaded fuels, lead substitutes, or fuel additives. Doing so can cause damage to the engine, fuel, and emission control systems.



Only use high quality petrol, as using lower quality fuels can cause damage to the engine, fuel, and emission control systems.



Fuel system cleaning agents should not be used, unless approved by Land Rover. Unapproved products may be harmful to fuel system components on your vehicle.

Octane rating

The minimum octane rating for fuel used is 91 RON. The vehicle will run on lower ratings, but it may cause pronounced engine knock or pinking. If the pinking is severe it can cause damage to the engine, fuel, and emission control systems.

Note: *Occasional, light, engine knock experienced while accelerating or climbing hills is acceptable.*

Fuel and refuelling

Alternative fuels for petrol engines

Ethanol

CAUTIONS

- ⚠ This vehicle is not suitable for use with fuels containing more than 10% Ethanol.
- ⚠ Do not use E85 fuels (85% Ethanol content). Equipment necessary for the use of fuels containing more than 10% Ethanol is not fitted to this vehicle. If E85 fuels are used, serious engine and fuels system damage will occur.

Fuels containing up to 10% Ethanol (grain alcohol) may be used. Ensure that the fuel has octane ratings no lower than those recommended for unleaded fuel. Most drivers will not notice any operating difference with fuel containing Ethanol. If a difference is detected, the use of conventional unleaded fuel should be resumed.

Methanol

Some fuels contain Methanol (Methyl or wood alcohol). If you use fuels containing Methanol the fuels must also contain co-solvents and corrosion inhibitors for Methanol. Also, do not use fuels which contain more than 3% Methanol even if they contain co-solvents and corrosion inhibitors. Fuel system damage or vehicle performance problems resulting from the use of such fuels is not the responsibility of Land Rover, and may not be covered under the warranty.

CAUTION

- ⚠ Wherever possible avoid using fuel containing Methanol.
-

Methyl Tertiary Butyl Ether (MTBE)

Unleaded fuel containing an oxygenate known as MTBE can be used provided that the ratio of MTBE to conventional fuel does not exceed 15%. MTBE is an Ether based compound derived from Petroleum, which has been specified by several refiners as the substance to enhance the Octane rating of fuel.

Reformulated gasoline

Several petroleum companies have announced the availability of reformulated fuels. These fuels are specially formulated to further reduce vehicle emissions. Land Rover fully supports all efforts to protect and maintain ambient air quality, and encourages the use of reformulated gasoline where available.

Diesel engined vehicles

Note: Land Rover vehicle's are capable of running with up to a 5% blend of bio-diesel in accordance with European Standard EN590.

Sulphur content

The Sulphur content of diesel used in Land Rover vehicles should not exceed 0.3%.

In some countries diesel will contain higher levels of Sulphur, which will require reduced service intervals to reduce the effects on engine components. If in doubt contact a local Land Rover Dealer/Authorised Repairer for advice.

Fuel and refuelling

RUNNING OUT OF FUEL

CAUTION

-  Avoid running out of fuel. Doing so can cause damage to the vehicle's engine, fuel, and emission control systems.

Note: If the vehicle does run out of fuel, a minimum of 4 litres (0.8 gallons) will be required to restart the engine. The vehicle will need to be driven 1.6-5 km (1-3 miles) in order to reset the engine management and monitoring systems.

Note: If the vehicle does run out of fuel, seeking qualified assistance is advisable.

FUEL CUT-OFF

The fuel system cut-off forms part of the Supplementary Restraint System (SRS) fitted to your vehicle. Following an impact, and depending on the severity, the fuel pump may be switched off.

Resetting the fuel cut-off

WARNING

-  The fuel cut-off should never be reset if you can smell fuel, or a leak can be seen. Doing so can lead to a fire which may cause personal injury or death.

1. Switch the ignition off and wait for one minute.
2. Turn the ignition on for 30 seconds.
3. Check the vehicle thoroughly for fuel leaks. If a leak is detected switch the ignition off immediately.
 - Do not start the vehicle if a leak is present. Seek qualified advice, and have the vehicle recovered.
4. If no leaks are detected, start the vehicle.

FUEL FILLER FLAP

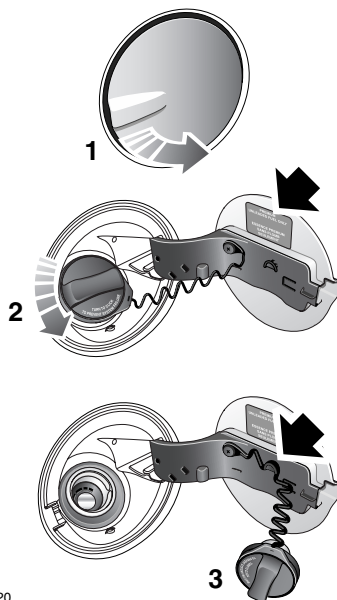

E82220

The fuel filler flap is located on the right-hand side of the vehicle, at the rear.

1. Ensure that the vehicle is fully unlocked, and pull the fuel filler flap open.
2. Twist the cap anti-clockwise to undo.
 - Ensure that you read, understand, and fully comply with all warnings and instructions given on the label affixed to the inside of the fuel filler flap.
3. Use the retaining clip to keep the filler cap out of the way whilst fuelling.

WARNINGS

-  Open the fuel filler cap slowly and allow the pressure to release before fully removing the cap to avoid fuel spillage due to rapid expansion.

Fuel and refuelling

WARNINGS



Take note of all warnings and instructions given on the label affixed to the inside of the filler flap. Failure to do so may result in injury or death.

REFUELLING

Fuel filler

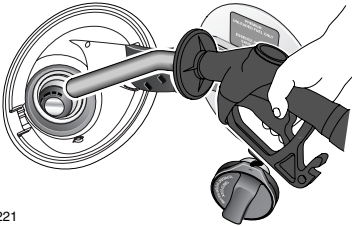

E82221

WARNINGS



When refuelling ensure that all windows, doors, and sunroof are fully closed, particularly if young children or animals are in the vehicle. Fuel vapour contains harmful chemical compounds, some of which may cause cancer.



Do not attempt to fill the tank to its maximum capacity. If the vehicle is to be parked on a slope, in direct sunlight, or high ambient temperature, expansion of the fuel could cause spillage. Filling station pumps are equipped with automatic cut-off sensing to avoid fuel spillage. Fill the tank slowly until the filler nozzle automatically cuts-off the supply. Do not attempt to fill the tank beyond this point.

CAUTIONS



Ensure that you check the fuel pump information carefully to ensure that you are putting the correct fuel into the vehicle. Filling a vehicle with the incorrect fuel can cause serious engine and fuel system damage.



If the vehicle is filled with incorrect fuel it is essential that you seek qualified assistance before you start the engine. Running the engine can cause serious engine and fuel system damage.

Note: Filling station pumps used for diesel commercial vehicles deliver fuel at a higher rate than normal. The higher fill rate can cause premature cut-off, and may cause fuel spillage. Therefore it is recommended that only standard light vehicle pumps are used.

Fuel and refuelling

TECHNICAL SPECIFICATIONS

Fuel consumption

Fuel consumption figures

Variant	Urban	Extra-urban	Combined	CO2 emissions
	l/100 km (mpg)	l/100 km (mpg)	l/100 km (mpg)	g/km
Petrol	15.8 l/100 km (17.9 mpg)	8.6 l/100 km (33 mpg)	11.2 l/100 km (25.2 mpg)	265 g/km
Diesel Manual gearbox	9.2 l/100 km (30.6 mpg)	6.2 l/100 km (45.5 mpg)	7.5 l/100 km (37.7 mpg)	194 g/km

Fuel specification

Petrol	Diesel
91-98 RON	EN 590

For additional information on fuel consumption figures and exhaust emissions, visit the Vehicle Certification Agency (VCA) website at <http://www.vcacarfueldata.org.uk/>.



Load carrying

GENERAL INFORMATION

Weights and load capacities

Note: It is the driver's responsibility to ensure that the maximum weights are not exceeded, and that the load is distributed correctly within the vehicle.

Information and values for the maximum weights can be found in the Weights section. See **WEIGHTS** (page 212).

Loadspace floor

WARNING



When removing or replacing the loadspace floor take care that your hands and fingers are placed so that they do not become trapped between the floor and vehicle. Ensure that children are kept at a safe distance to avoid accidental injury.

The loadspace floor is reversible to prevent damage/staining of the carpet when transporting muddy boots or wet dogs for example.

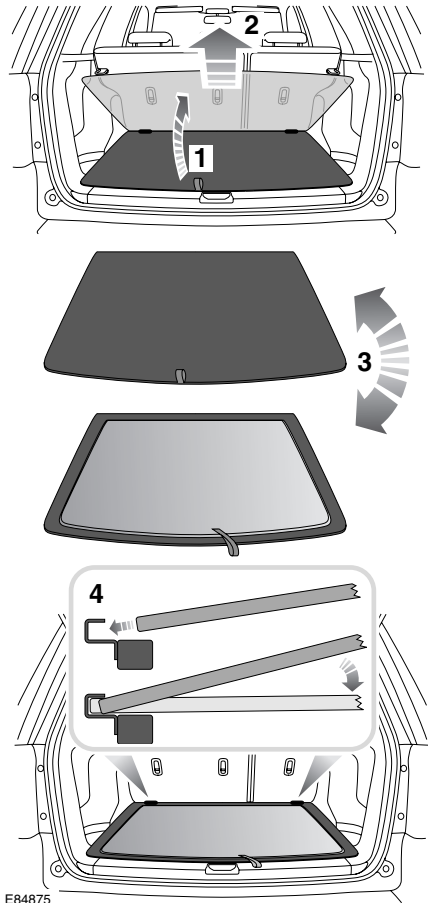

E84875

To reverse the loadspace floor :-

1. Raise the loadspace floor.
2. Pull the floor towards the rear of the vehicle, and remove it from the vehicle.
3. Turn the floor over so that the required surface is uppermost.
4. Insert the forward edge of the floor into the retaining channel, and lower the floor into position.

Load carrying

LUGGAGE ANCHOR POINTS

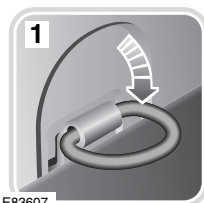
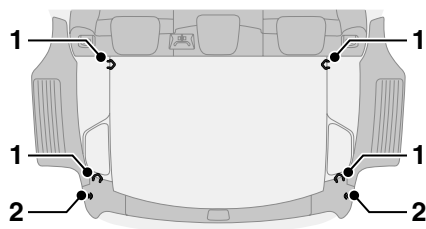

E83607

Note: A range of approved luggage retention accessories are available from your Land Rover Dealer/Authorised Repairer.

Reversible floor

The luggage compartment floor has been designed with two load surfaces. A carpeted side, which can be used in the normal way, and a hard, wipe clean surface. The hard surface can be used when transporting items which are wet, dirty, or may damage the carpeted surface.

To change between the two surfaces simply remove the floor panel and reinstall it with the required surface facing upwards.

WARNINGS



All items carried in the luggage area should be properly secured. Loose items can cause serious injury or death in the event of an accident or sudden manoeuvre.



Do not use the bag hooks to secure heavy items. Items which are not properly secured can cause serious injury or death during an accident or sudden manoeuvre.

1. Load securing rings.
 - Four load securing rings are provided in the rear luggage area to assist in safely securing items carried.
2. Bag hooks.
 - A bag hook is provided on each side of the load area. These should be used to secure relatively light items such as shopping bags.

Load carrying

LUGGAGE COVERS

Fitting the luggage cover

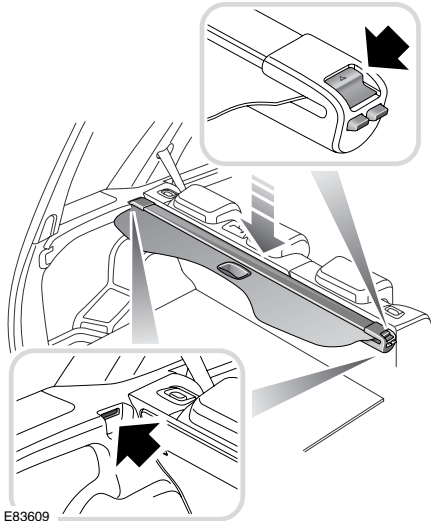

WARNING



When fitting the luggage cover ensure that the location pegs on the left-hand side are fully engaged, and the release button on the right-hand side is fully home. Failure to do so may allow the luggage cover to move during an accident or sudden manoeuvre.

1. Insert the location peg on the left-hand end of the luggage cover into the slot.
2. Lower the right-hand end into position by pulling back the release button.
3. Ensure that when the cover is in position the release button returns to its engaged position.

Reverse the installation procedure to remove the luggage cover.

Operating the luggage cover

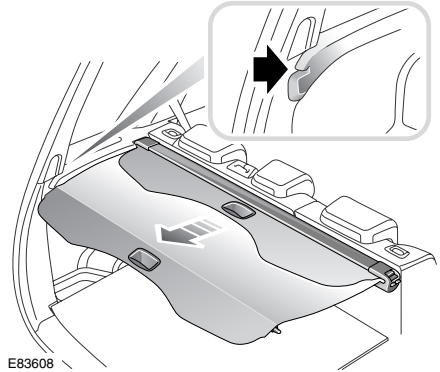

WARNING



Never place objects on top of the luggage cover. During an accident or sudden manoeuvre loose objects can cause serious injury or death.

CAUTIONS



When retracting the cover, ensure that no items are on top of the cover. Items left on top of the cover, paper or fabrics for example, may be drawn into the mechanism and cause it to jam.



If the cover is damaged in any way, it should not be used. The damaged area may prevent the cover from operating correctly.

1. Pull the luggage cover blind towards the rear of the vehicle.
2. Engage the end pegs into the recesses provided in the luggage space side trims.

Towing

TOWING A TRAILER

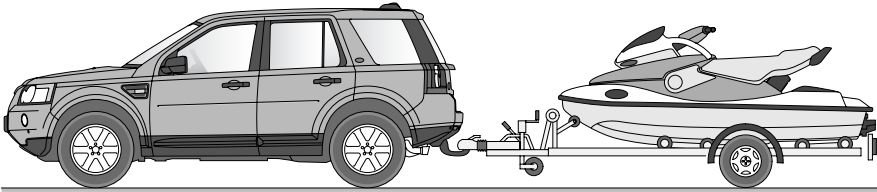

E82249

WARNINGS

 Never exceed the maximum weights for either the vehicle, or the trailer. Doing so can cause accelerated wear and damage to the vehicle. It can also adversely affect vehicle stability and braking, which in turn can lead to loss of control and increased braking distance resulting in a rollover or crash.

 To preserve handling and stability, only fit Land Rover approved towing accessories.

 Never use towing eyes, or lashing points to tow a trailer. They have not been designed for this purpose, and doing so may cause them to fail resulting in injury or death.

Note: *It is the driver's responsibility to ensure that the towing vehicle, and the trailer are being used correctly, and in accordance with manufacturers recommendations and any applicable legislation.*

Trailer electrical connection

CAUTION

 Only connect approved electrical circuits, which are in good condition to the trailer socket. Connecting incorrect, or faulty circuits may seriously damage the vehicle's electrical circuits.

Note: *The rear parking sensors are automatically disabled when the trailer electrical connection is made.*

The vehicle's electrical system has been designed to support all towing requirements, and comply with legal requirements for the specific territory in which the vehicle is first sold.

Towing

LEVELLING

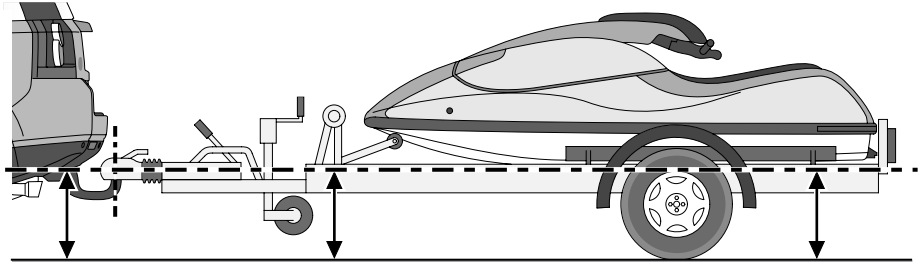

E82250

To maintain vehicle stability, it is essential that the trailer is loaded so that it remains parallel to the ground. This is particularly important when towing twin axled trailers.

ESSENTIAL TOWING CHECKS

- The trailer should be parallel to the ground when loaded.
- When calculating the laden weight of the trailer remember to include the weight of the trailer, plus the weight of the load.
- If the load can be divided between the vehicle and trailer, loading more weight into the vehicle will generally improve stability. Do not exceed the vehicle's weight limits. See **WEIGHTS** (page 212).
- Ensure that all applicable regulations and legislation are complied with when loading and towing a trailer.
- Increase rear tyre pressures of the towing vehicle to those for maximum vehicle loading conditions. See **WEIGHTS** (page 212).
- Ensure trailer tyre pressures are set to trailer manufacturer's recommendations.
- If the vehicle is loaded to maximum Gross Vehicle Weight (GVW) the nose weight is limited to 150 kg (330 lbs).
- If it is necessary to increase the nose weight, up to a maximum of 250 kg (550 lbs) the vehicle load should be reduced accordingly. This ensures that the GVW, and maximum rear axle load are not exceeded.
- Ensure that a suitable breakaway cable or secondary coupling is used. Refer to the trailer manufacturer's instructions for guidance.
- Ensure that the tow ball is secure.
- Check the operation of all trailer lights.

WARNING



Do not loop the breakaway cable over the tow ball as it may slide off.

Towing

RECOMMENDED TOWING WEIGHTS

Maximum permissible towing weights	On-road	Off-road
Unbraked trailers	750 kg (1650 lbs)	750 kg (1650 lbs)
Trailers with overrun brakes	2000 kg (4400 lbs)	750 kg (1650 lbs)
Nose weight	150 kg (330 lbs)	150 kg (330 lbs)

WARNING



Do not exceed the Gross Vehicle Weight (GVW), maximum rear axle weight, maximum trailer weight, or nose weight. Exceeding any of these limits could cause instability and loss of control. See **WEIGHTS** (page 212).

Note: When towing the maximum permissible gross vehicle weight can be increased by a maximum of 100 kg (220 lbs) provided that the road speed is limited to 100 km/h (60 mph).

Note: When calculating rear axle loading, remember that the trailer nose weight, the load in the vehicle's luggage area, weight on the roof rack, and the weight of rear seat passengers must all be added together.

Towing

TOW BAR

Tow bar dimensions and mounting points

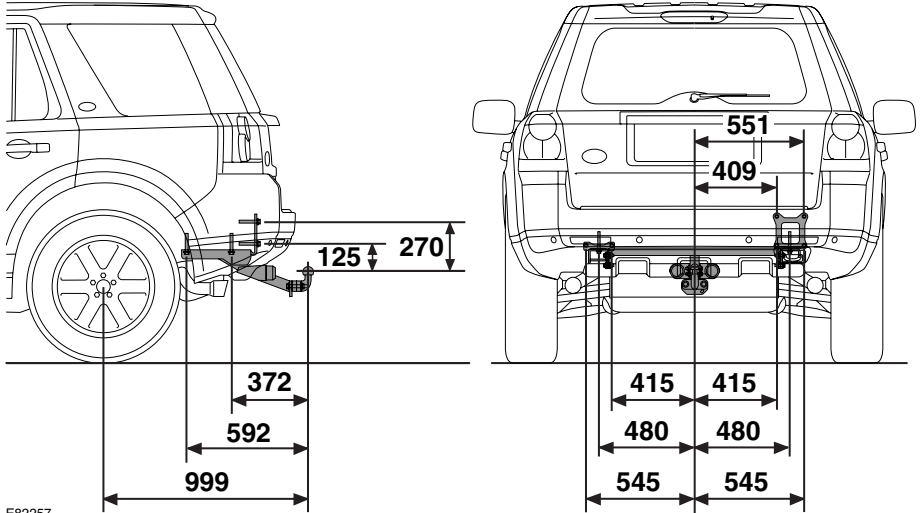

E82257

Note: Dimensions given are in millimetres.

Vehicle care

CLEANING THE ALLOY WHEELS

CAUTION

- ! Do not use non-approved, or acid based wheel cleaners. These can damage the wheel coating which may lead to corrosion of the wheel rims.

Wash the wheels with soap and water, this should be done more frequently when the wheels are exposed to heavy dirt deposits, salt, clay etc. If you are unsure how often to clean the wheels in particular conditions, seek advice from your Land Rover Dealer/Authorised Repairer.

Land Rover approved wheel cleaner should be used to remove heavy soiling.

CLEANING THE EXTERIOR



E79400

CAUTIONS

- ! Some high pressure cleaning systems are sufficiently powerful to penetrate door/window seals, and damage trim and door locks. Never aim the water jet directly at the engine air intake, heater air intakes, body seals (doors, sunroof, windows etc) or at any components which may be damaged (lights, mirrors, exterior trim etc).

CAUTIONS

- ! Do not use a power wash system in the engine bay area as it may damage fragile components, electrical systems etc.
- ! Ensure that you read and comply with all warnings and instructions supplied with any cleaning products.
- ! Never use cleaning products which are not approved for use on vehicles.

Washing the vehicle

CAUTION

- ! Substances which are corrosive, such as bird droppings, tree resin, dead insects, tar spots, road salt, and industrial fall out, can damage the vehicle's paintwork. Any such deposits should be removed as soon as possible to prevent damage to the vehicle's paintwork.

Remove heavy deposits of mud and dirt with a hose before washing the vehicle.

Wash the vehicle frequently using a sponge and generous quantities of cold or luke warm water containing a suitable car shampoo. Rinse thoroughly, and dry with a chamois leather, or synthetic substitute.

Removing tar spots

Use white spirit to remove tar spots and stubborn grease stains from paintwork. Ensure that after using white spirit, the area is washed immediately with soapy water to remove all traces of spirit.

Vehicle care

Underbody maintenance

Corrosive materials used on highways to control snow and ice, as well as accumulations from off-road driving or wading in salt water, can collect on the vehicle's underbody. If these materials are not removed accelerated corrosion can occur. Regularly flush the underbody with plain water, and pay particular attention to areas where mud and debris collect.

If damage or corrosion are detected, have the vehicle checked by a Land Rover Dealer/Authorised Repairer as soon as possible.

Glass and mirrors

The rear screen, and mirror glass' should only be cleaned using soapy water and a soft cloth. This will avoid damaging the reflective surface of the mirror, and the heating elements and antenna in the rear screen.

Never use abrasive cleaning products, or metal ice scrapers on the mirrors or the front/rear screens.

Cleaning after off-road driving

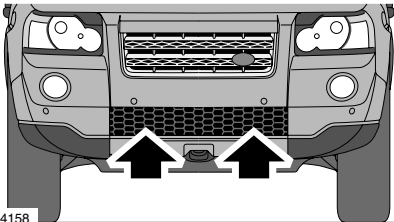

E84158

CAUTION

⚠ Ensure that the areas around air intakes and the front grille are clean and clear of debris. Pay particular attention to the lower grille and radiator. Failure to do so may cause the engine to overheat, leading to severe engine damage.

Ensure that the vehicle underside is cleaned as soon as possible after driving off-road. Further information on cleaning after off-road use is available in the off-road driving handbook. This can be found on-line at

<http://www.ownerinfo.landrover.com>.

CLEANING THE INTERIOR

WARNING



Ensure that you read all of the information and instructions for use provided with cleaning products.

Some products contain substances that are harmful and can cause health problems if used incorrectly.

CAUTION



Some products, if used incorrectly can cause damage to the interior surfaces of the vehicle.

Plastic and cloth

WARNING



Do not polish the instrument panel. Polished surfaces are reflective, and may interfere with the drivers view.

Clean plastic or cloth faced surfaces with warm water and non-detergent soap. Then wipe clean with a soft cloth.

Leather

CAUTIONS



Only use cleaning products specifically designed for use on leather. Do not use chemical, alcohol, or abrasive materials, as they will cause rapid deterioration of the leather. The use of products which are not approved will invalidate your warranty.

Vehicle care

CAUTIONS



If you are in any doubt as to which products to use, consult your Land Rover Dealer/Approved repairer.

Leather should be cleaned and protected at least every six months.

Land Rover recommend the use of leather cleaning kit BAC500490. Use only in accordance with the instructions.

Note: *Some materials/fabrics are prone to dye transfer, which can cause unsightly discolouration of lighter coloured leathers. Affected areas should be cleaned and re-protected as soon as possible.*

Carpets and fabrics

Only clean with a dilute solution of an approved upholstery cleaner. It is advisable to test all cleaners on a concealed area before use.

Instrument pack, clock, and audio equipment

Only use a soft dry cloth to clean the instrument pack, clock, and audio equipment. Do not use cleaning fluids or sprays.

Seat belts

WARNING



Do not allow any water, cleaning products, or fabric from cloths to enter the seat belt mechanism. Any substance which enters the mechanism may affect the performance of the seat belt in an impact.

Extend the seat belts fully, then use warm water and a non-detergent soap to clean. Allow the seat belts to dry naturally whilst fully extended.

Note: *Whilst cleaning the seat belt, take the opportunity to examine the webbing for damage/wear. Any wear or damage should be reported to, and rectified by, a Land Rover Dealer/Approved repairer.*

Airbag module covers

WARNINGS



Airbag covers should only be cleaned using a slightly dampened cloth, and a small amount of upholstery cleaner.



Do not allow the airbag covers, or surrounding areas, to become contaminated with liquids. Any substance which enters the mechanism can prevent correct deployment of an airbag during an impact.

REPAIRING MINOR PAINT DAMAGE

Regularly inspect the paintwork for damage. Any stone chips, fractures, or deep scratches, in the paint/bodywork should be repaired promptly. Bare metal will corrode quickly, and if left untreated can result in expensive repairs.

Minor chips and scratches can be touched up using materials and advice available from a Land Rover Dealer/Authorised Repairer. Larger areas of damage will require professional repair, and you should consult a Land Rover Dealer/Authorised Repairer.

Maintenance

GENERAL INFORMATION

Regular systematic maintenance is the key to ensuring the continued reliability and efficiency of your vehicle.

Maintenance is the owner's responsibility and you must ensure that owner maintenance operations, oil services, inspections and brake fluid and coolant changes are carried out when required and according to the manufacturer's recommendations.

The routine maintenance requirements for your vehicle are shown in the Service Portfolio book. Most of this necessary workshop maintenance requires specialised knowledge and equipment, and should preferably be entrusted to a Land Rover Dealer/Authorised Repairer.

Service intervals

On vehicles fitted with a message centre, an upcoming service interval will be notified to the driver in one of two ways. As a distance left to travel, or a number of days remaining. Once the distance or time are exceeded the display will show a negative value (-) to indicate that a service is overdue.

When the ignition is turned on the Odometer display will show the service information for five seconds.

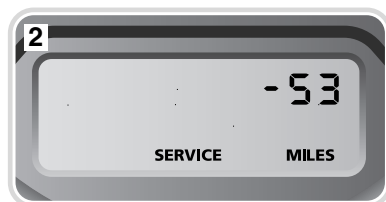
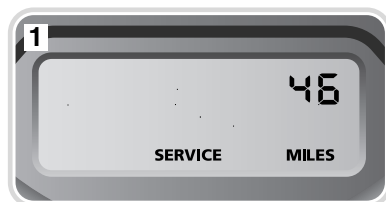

E86516

1. Distance to service.
2. Distance by which service is overdue.

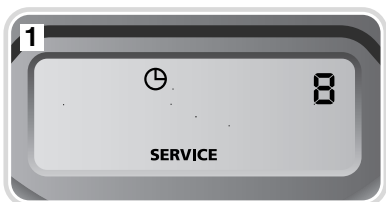

E86517

1. Number of days to service.
2. Number of days by which service is overdue.

Maintenance

One or both types of service interval (distance and time) may be displayed. For example, if an engine oil service is due based on mileage, and a brake fluid change is due based on time, both distance and time countdowns will display.

Service Portfolio

The Service Portfolio book includes a Service Record section, which enables a record to be kept of all the servicing and inspections that are carried out on the vehicle. This section of the book also has an area for brake fluid changes to be recorded.

Ensure your service provider signs and stamps the book after each service and inspection.

Owner Maintenance

CAUTION

 Any significant or sudden drop in fluid levels, or uneven tyre wear, should be reported to a qualified technician without delay.

In addition to the routine maintenance, a number of simple checks must be carried out more frequently. Advice is given on the pages that follow.

Daily checks

- Operation of lamps, horn, direction indicators, wipers, washers and warning indicators.
- Operation of seat belts and brakes.
- Look for fluid deposits underneath the vehicle that might indicate a leak.

Weekly checks

- Engine oil level. See **ENGINE OIL CHECK** (page 162).
- Engine coolant check. See **ENGINE COOLANT CHECK** (page 163).
- Brake/clutch fluid level. See **BRAKE AND CLUTCH FLUID CHECK** (page 165).

- Power steering fluid level. See **POWER STEERING FLUID CHECK** (page 166).
- Screen washer fluid level. See **WASHER FLUID CHECK** (page 167).
- Tyre pressures and condition.
- Operate air conditioning.

***Note:** The engine oil level should be checked more frequently if the vehicle is driven for prolonged periods at high speeds.*

Driving in arduous conditions

When a vehicle is operated in extremely arduous conditions, more frequent attention must be paid to servicing requirements.

For example, if your vehicle experiences deep wading conditions, even daily servicing could be necessary to ensure the continued safe and reliable operation of the vehicle.

Arduous driving conditions include:

- Driving in dusty and/or sandy conditions.
- Driving on rough and/or muddy roads and/or wading.
- Driving in extremely hot conditions.
- Towing a trailer or driving in mountainous conditions.

Contact a Land Rover Dealer/Authorised Repairer for advice.

Emission control

Your vehicle is fitted with various items of emission and evaporative control equipment, designed to meet specific territorial requirements. You should be aware that unauthorised replacement, modification or tampering with this equipment by an owner or repair shop, may be unlawful and subject to legal penalties.

Maintenance

In addition, engine settings must not be tampered with. These have been established to ensure that your vehicle complies with stringent exhaust emission regulations. Incorrect engine settings may adversely affect exhaust emissions, engine performance and fuel consumption. They may also cause high temperatures, which will result in damage to the catalytic converter and the vehicle.

Road testing dynamometers (rolling roads)

Because your vehicle is equipped with anti-lock brakes and four wheel drive, it is essential that any dynamometer testing is carried out only by a qualified person, familiar with the dynamometer testing and safety procedures practised by Land Rover Dealers/Authorised Repairers.

Safety in the garage

WARNINGS



-  If the vehicle has been driven recently, do not touch exhaust and cooling system components until the engine has cooled.
-  Never leave the engine running in an unventilated area - exhaust gases are poisonous and extremely dangerous.
-  Do not work beneath the vehicle with the wheel changing jack as the only means of support.
-  Keep your hands and clothing away from drive belts and pulleys.
-  Remove metal wrist bands and jewellery, before working in the engine compartment.
-  Do not touch electrical leads or components while the engine is running, or with the starter switch turned on.

WARNINGS

-  Do not allow tools or metal parts of the vehicle to make contact with the battery leads or terminals.

Fuel system

WARNINGS

-  Under no circumstances should any part of the fuel system be dismantled or replaced by anyone other than a suitably qualified vehicle technician. Failure to comply with this instruction, may result in fuel spillage with a consequent serious risk of fire.
-  Ensure sparks and naked lights are kept away from the engine compartment.
-  Wear protective clothing, including, where practicable, gloves made from an impervious material.

Poisonous fluids

Fluids used in motor vehicles are poisonous and should not be consumed or brought into contact with open wounds. These include; battery acid, antifreeze, brake, clutch and power steering fluid, petrol, diesel, engine oil and windscreen washer additives.

For your own safety, always read and obey all instructions printed on labels and containers.

Used engine oil

Prolonged contact with engine oil may cause serious skin disorders, including dermatitis and cancer of the skin. Always wash thoroughly after contact.



It is illegal to pollute drains, water courses or soil. Use authorised waste disposal sites to dispose of used oil and toxic chemicals.

Maintenance

OPENING AND CLOSING THE BONNET

Opening the bonnet

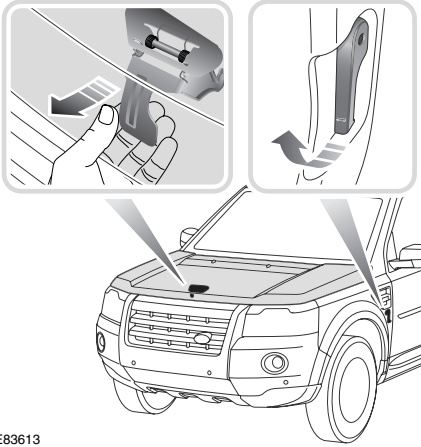

E83613

1. Pull the bonnet release handle located on the left-hand side of the vehicle.
2. Lift the bonnet safety catch lever located below the centre point of the words LAND ROVER, and raise the bonnet.

Closing the bonnet

WARNING



Do not drive with the bonnet retained by the safety catch alone.

1. Lower the bonnet until the safety catch engages. Using both hands, press the bonnet down until the catches click.
2. Check that both catches are fully engaged by attempting to lift the front edge of the bonnet. This should be free from all movement.

Maintenance

ENGINE COMPARTMENT OVERVIEW

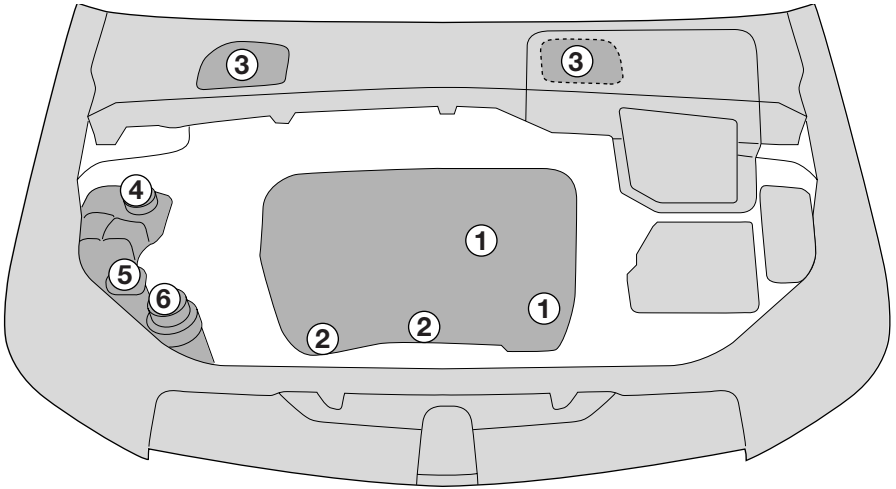

E83614

1. Engine oil filler caps (Black)

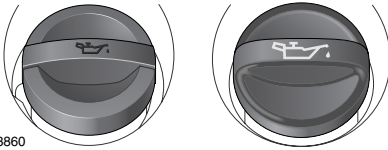

E83860

2. Engine oil dipsticks (Yellow)

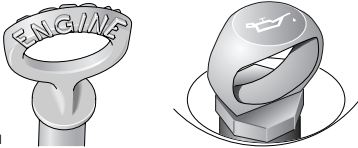

E83861

3. Brake fluid reservoir cap (Black)

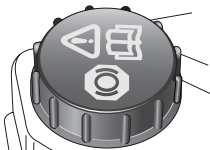

E83862

4. Coolant reservoir cap (Black)

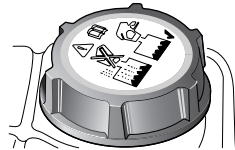

E83863

5. Washer fluid reservoir cap (Blue)

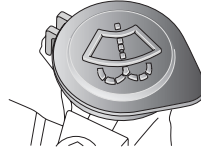

E83864

6. Power steering fluid reservoir cap (Black)

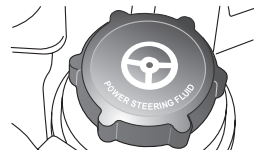

E83865

Maintenance

WARNINGS

 While working in the engine compartment, always observe the safety precautions listed under Safety in the garage. See **GENERAL INFORMATION** (page 157).

 Do not drive the vehicle if there is a possibility that leaked fluid will come into contact with a hot surface, such as the exhaust. A resulting fire may cause death or serious injury.

ENGINE OIL CHECK

The oil consumption of an engine is influenced by many factors. Under high loads an engine will consume more oil than usual. Diesel engines consume slightly more oil than petrol engines.

Check the oil level weekly, when the engine is cold and with the vehicle resting on level ground.

Checking the oil level

Note: *If it is necessary to check the oil level when the engine is hot, switch off the engine and let the vehicle stand for five minutes to allow the oil to drain back into the sump. Do not start the engine.*

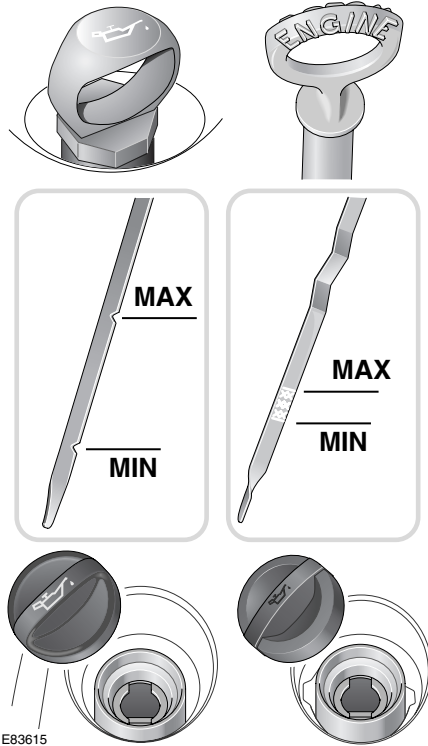

1. Withdraw the dipstick and wipe the blade clean with a lint free cloth.
2. Fully re-insert the dipstick and withdraw again to check the oil level. Never allow the oil level to fall below the lower mark or notch on the dipstick.

As a general guide, if the level on the dipstick:

- Is nearer to the upper mark or notch than the lower, add no oil.
- Is nearer to the lower mark or notch than the upper, add half a litre (one pint) of oil.
- Is below the lower mark or notch, add one litre (two pints) of oil and re-check the level after a further five minutes.

Maintenance

Topping up the oil

CAUTIONS

- ❗ Your vehicle warranty may be invalidated if damage is caused by using oil that does not meet the required specification.
- ❗ Failure to use an oil that meets the required specification could cause excessive engine wear, a build up of sludge and deposits, and increase pollution. It could also lead to engine failure.
- ❗ Overfilling with oil could result in severe engine damage. Oil should be added in small quantities and the level re-checked to ensure that the engine is not overfilled.

1. Unscrew the oil filler cap.
2. Add oil to maintain the level between the **MIN** and **MAX** marks or notches on the dipstick. Clean up any oil spilled during topping-up.
3. Check the oil level again after 5 minutes.

It is essential to use the correct specification oil, and to ensure it is suitable for the climatic conditions in which the vehicle is to be operated.

Note: The approximate quantity of oil required to raise the level from **MIN** to **MAX** on the dipstick is 0.8 litres (1.4 pints) - petrol models or 1.5 litres (2.6 pints) - diesel models.

Engine oil specification

Model	Specification
Petrol engine	Use only 0W-30 engine oil, meeting ACEA A5 or B5 specification.
Diesel engine	Use only 5W-30 oil meeting Ford 913-B specification.

Land Rover recommends Castrol oils.

ENGINE COOLANT CHECK



If the quantity of fluid in the coolant reservoir drops below the recommended level, an amber warning indicator in the instrument pack will illuminate. Stop the vehicle and check the coolant level.

On vehicles with a message centre, the message **LOW COOLANT LEVEL** or **COOLING SYSTEM FAULT MONITOR GAUGE** will be displayed in place of the warning indicator.

Checking the coolant level

CAUTION

- ❗ Running the engine without coolant will cause serious engine damage.

The coolant level in the expansion tank should be checked at least weekly (more frequently in high mileage or arduous operating conditions). Always check the level when the system is cold.



E83616

Ensure the coolant level is maintained between the level indicator marks located on the side of the expansion tank.

Maintenance

If the level has fallen appreciably, suspect leakage or overheating and arrange for the vehicle to be examined by a qualified technician.

Topping up the coolant

WARNINGS

 Never remove the filler cap when the engine is hot - escaping steam or scalding water could cause serious personal injury.

 Avoid spilling antifreeze onto a hot engine - a fire may result.

 Unscrew the filler cap slowly, allowing the pressure to escape before removing completely.

CAUTION

 When travelling in territories where the water supply contains salt, always ensure you carry a supply of fresh (rain or distilled) water. Topping up with salt water will cause serious engine damage.

Top-up to the upper level indicator mark located on the side of the expansion tank. Use only a 50% mix of water and Texaco XLC antifreeze.

Note: *In an emergency - and only if the approved antifreeze is unavailable - top-up the cooling system with clean water, but be aware of the resultant reduction in frost protection. Do not top-up or refill with conventional antifreeze formulations. If in doubt consult a qualified technician.*

Ensure the cap is tightened fully after top-up is completed by turning the cap until the ratchet cap clicks.

Antifreeze

WARNINGS

 Antifreeze is poisonous and can be fatal if swallowed - keep containers sealed and out of the reach of children. If accidental consumption is suspected, seek medical attention immediately.

 If the fluid comes into contact with the skin or eyes, rinse immediately with plenty of water.

CAUTIONS

 The use of non-approved antifreeze will have an adverse effect on the engine cooling system and therefore engine durability.

 Antifreeze will damage painted surfaces; soak up any spillage with an absorbent cloth immediately and wash the area with a mixture of car shampoo and water.

Antifreeze contains important corrosion inhibitors. The antifreeze content of the coolant must be maintained at 50% \pm 5% all year round (not just in cold conditions). To ensure that the anti-corrosion properties of the coolant are retained, the antifreeze content should be checked once a year and completely renewed every ten years, regardless of distance travelled. Failure to do so may cause corrosion of the radiator and engine components.

The specific gravity of a 50% antifreeze solution at 20°C (68°F) is 1.068 and protects against frost down to -40°C (-40°F).

Maintenance

BRAKE AND CLUTCH FLUID CHECK

WARNINGS

 Brake fluid is highly toxic - keep containers sealed and out of the reach of children. If accidental consumption of fluid is suspected, seek medical attention immediately.

 If the fluid comes into contact with the skin or eyes, rinse immediately with plenty of water.

 Take care not to spill the fluid onto a hot engine - a fire may result.

 Do not drive the vehicle with the fluid level below the **MIN** mark.

 If the quantity of fluid in the brake/clutch reservoir drops below the recommended level, a red warning indicator in the instrument pack will illuminate or the message **CHECK BRAKE FLUID** will be displayed in the message centre.

Note: *If the warning indicator illuminates, or the message is displayed while the vehicle is being driven, stop the vehicle as soon as safety permits by gently applying the brakes.*

Check and top-up the fluid level if necessary.

Checking the fluid level

WARNING

 Seek qualified assistance immediately if brake pedal travel is unusually long or if there is any significant loss of brake fluid. Driving under such conditions could result in extended stopping distances or complete brake failure.

With the vehicle on level ground, check the fluid level at least every week (more frequently in high mileage or arduous operating conditions).

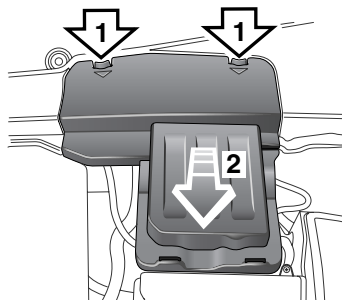

E83617

1. Release the two catches and lift the rear of the cover.
2. Slide the cover forward and lift it off completely.

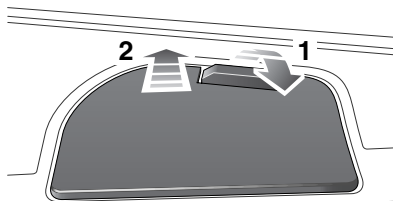

E84161

1. Release the catch.
2. Remove the cover.

Maintenance

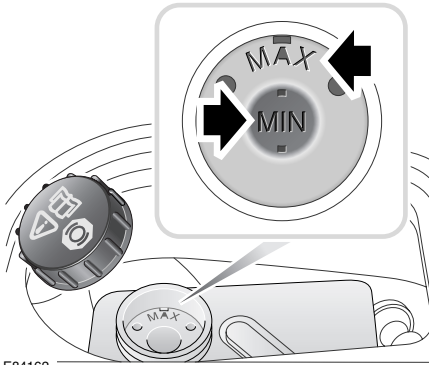

E84162

3. Clean the filler cap before removing to prevent dirt from entering the reservoir.
4. Remove the filler cap.
5. The brake fluid level should be between the **MIN** and the **MAX** marks.

The fluid level may drop slightly during normal use as a result of brake pad wear but should not be allowed to drop below the **MIN** mark.

Topping up the fluid

CAUTIONS

- ! Brake fluid will damage painted surfaces. Soak up any spillage with an absorbent cloth immediately and wash the area with a mixture of car shampoo and water.
- ! Only use new fluid from an airtight container (fluid from opened containers or fluid previously bled from the system will have absorbed moisture, which will adversely affect performance, and must not be used).

1. Top-up the reservoir to the **MAX** mark using Shell DOT4 ESL brake fluid. If Shell DOT4 ESL is not available, a low viscosity DOT4 brake fluid that meets ISO 4925 class 6 and Land Rover LRES22BF03 requirements may be used.

2. Replace the cap.
3. Fit the reservoir cover in the reverse order of removal.

POWER STEERING FLUID CHECK

WARNINGS

! Power steering fluid is highly toxic. Keep containers sealed and out of reach of children. If accidental consumption of fluid is suspected, seek medical attention immediately.

! If the fluid comes into contact with the skin or eyes, rinse immediately with plenty of water.

Checking the fluid level

CAUTIONS

- ! The engine must not be started if the fluid level has dropped below the **MIN** mark. Severe damage to the steering pump could result.
- ! Seek qualified assistance immediately if there is a noticeable drop in the fluid level. Severe damage to the steering pump could result.
- ! If fluid loss is slow, the reservoir may be topped-up to the upper level mark to enable the vehicle to be driven to a repair facility for examination. However, it is recommended that you seek qualified assistance before driving the vehicle.

Check and top-up the fluid with the vehicle on level ground, engine switched off, and the system cold. Ensure that the steering wheel is not turned after stopping the engine.

Maintenance

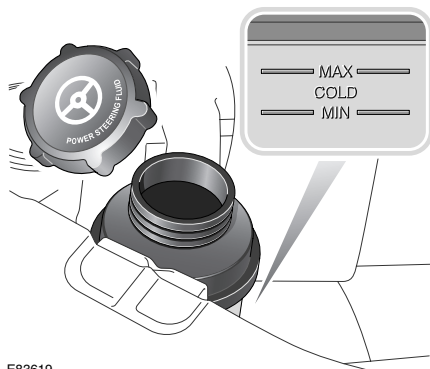

E83619

The level of fluid can be seen through the translucent body of the reservoir.

The fluid level should be between the **MIN** and the **MAX** marks.

Topping up the fluid

CAUTIONS

- ❗ Power steering fluid will damage painted surfaces. Soak up any spillage with an absorbent cloth immediately and wash the area with a mixture of car shampoo and water.
- ❗ Do not fill the reservoir above the **MAX** mark.

1. Clean the filler cap before removing to prevent dirt from entering the reservoir.
2. Remove filler cap.
3. Using Pentosin CHF202 fluid, top-up the reservoir until the fluid level is between the **MIN** and **MAX** marks.
4. Replace filler cap.

WASHER FLUID CHECK

WARNINGS

⚠ Some screen washer products are inflammable, particularly if high or undiluted concentrations are exposed to sparking. Do not allow screen washer fluid to come into contact with naked flames or sources of ignition.

⚠ If the vehicle is operated in temperatures below 4°C (40°F), use a washer fluid with frost protection. In cold weather, failure to use a washer fluid with frost protection, could result in impaired vision and increase the risk of a vehicle crash.

CAUTIONS

- ❗ Do not use an antifreeze or vinegar/water solution in the washer reservoir - antifreeze will damage painted surfaces, while vinegar can damage the windscreen washer pump.
- ❗ Body panels may suffer discolouration as a result of screen washer fluid spillage. Take care to avoid spillage, particularly if an undiluted or high concentration is being used. If spillage occurs, wash the affected area immediately with water.



If the quantity of fluid remaining in the washer reservoir drops to less than one litre, an amber warning indicator in the instrument pack will illuminate or the message **LOW WASHER FLUID** will be displayed in the message centre.

Maintenance

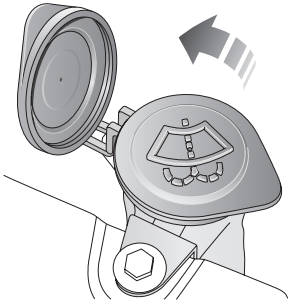

E83620

The washer reservoir supplies both front and rear screen washer jets and headlamp washer jets.

Check and top-up the reservoir level at least every week. Always top-up with screen washer fluid to prevent freezing.

Operate the washer switches periodically to check that the nozzles are clear and properly directed.

Topping up the fluid

1. Clean the filler cap before removing to prevent dirt from entering the reservoir.
2. Remove filler cap.
3. Top-up the reservoir until the fluid is visible in the filler neck.
4. Replace filler cap.

Washer reservoir capacity

- Models without headlamp wash - 3.1 litres (5.45 pints).
- Models with headlamp wash - 5.8 litres (10.2 pints).

Maintenance

TECHNICAL SPECIFICATIONS

Lubricants and fluids

Part	Variant	Specification
Engine oil	Diesel vehicles	SAE 5W-30 meeting Ford 913-B specification.
Engine oil	Petrol vehicles	SAE 0W-30 meeting ACEA A5 or B5 specification.
Main gearbox oil	Manual transmission	Castrol MTF 97309
Main gearbox oil	Automatic transmission	Esso JWS3309US
Power transfer unit fluid	Diesel vehicles	Castrol BOT119
Power transfer unit fluid	Petrol vehicles	Castrol BOT118
Rear differential oil	All vehicles	Castrol EPX
Rear differential on demand coupler fluid	All vehicles	STAT OIL SL01-301
Power steering fluid	All vehicles	Pentosin CHF202 PAS fluid
Brake fluid	All vehicles	Shell DOT4 ESL ¹
Screen washer	All vehicles	Screen wash with frost protection
Coolant	All vehicles	50% mixture of Texaco XLC antifreeze and water.

¹ If Shell DOT4 ESL is not available, a low viscosity DOT4 brake fluid that meets ISO 4925 class 6 and Land Rover LRES22BF03 requirements may be used.

Maintenance

Capacities

Item	Variant	Capacity
Fuel tank	Diesel vehicles	68 litres (15 gallons)
	Petrol vehicles	70 litres (15.4 gallons)
Engine oil refill and filter change	Diesel vehicles	5.86 litres (10.31 pints)
	Petrol vehicles	7.7 litres (13.55 pints)
Engine oil MIN to MAX on dipstick	Diesel vehicles	1.5 litres (2.64 pints)
	Petrol vehicles	0.8 litres (1.4 pints)
Manual gearbox	All vehicles	2.0 litres (3.52 pints)
Automatic gearbox	All vehicles	7 litres (12.32 pints)
Power transfer unit	All vehicles	0.75 litres (1.32 pints)
Rear differential	All vehicles	0.7 litres (1.23 pints)
Rear differential coupling unit	All vehicles	0.65 litres (1.14 pints)
Washer reservoir	With headlamp wash	5.8 litres (10.2 pints)
Washer reservoir	Without headlamp wash	3.1 litres (5.45 pints)
Cooling system (fill from dry)	All vehicles	8.0 litres (14.07 pints)

The quoted capacities are approximate and provided as a guide only. All oil levels must be checked using the dipstick or level plugs as applicable.

Vehicle battery

BATTERY WARNING SYMBOLS



Do not allow any naked flames, or other sources of ignition near the battery as the battery may emit explosive gasses.



Ensure that when working near, or handling the battery, suitable eye protection is worn. This will reduce the risk of eye damage caused by acid splashes.



To prevent risk of injury, do not allow children near the battery.



Be aware that the battery may emit explosive gasses.



The battery contains acid which is extremely corrosive, and toxic.

BATTERY CARE

WARNINGS



Do not allow the battery electrolyte (fluid) come into contact with your skin or eyes. It is both corrosive and toxic, and the resulting injuries can be severe. If any electrolyte does come into contact with your skin or eyes, immediately rinse the affected area with clean, cold water. Immediate medical advice will be required.



If battery electrolyte comes into contact with your skin and/or clothes you should remove the affected clothing and flush the skin with copious amounts of water. Seek medical assistance immediately.



If battery electrolyte comes into contact with your eyes, flush with copious amounts of clean cold water. Seek medical assistance immediately, and continue to flush with water.



If swallowed, battery electrolyte can be fatal. If electrolyte is swallowed seek medical assistance immediately.



Do not connect any 12 volt equipment directly to the battery terminals. Doing so may cause a spark, which can result in an explosion.



The cell plugs and vent pipe must be in place at all times when the battery is connected to the vehicle. Ensure that the vent pipe is clear of obstructions and not kinked. Failure to do so may cause a pressure build up in the battery, resulting in an explosion.



Do not expose the battery to a naked flame or spark as the battery produces explosive, flammable gas.



Never jump start (boost) or charge, a frozen battery. Doing so can result in an explosion.

Vehicle battery

WARNINGS

 Remove all metal jewellery before working on, or near, the battery, and never allow metal tools or vehicle components to come into contact with the battery terminals. Metal objects can cause sparks, and/or short circuits, resulting in an explosion.

 Do not allow the battery posts or terminals to come into contact with your skin. They contain lead, and lead compounds which are toxic. Always wash your hands thoroughly after handling the battery.

CAUTION

 Do not allow battery electrolyte to come into contact with fabrics or painted surfaces. If battery electrolyte comes into contact with any surface, the surface should be washed down immediately with copious amounts of clean water. Battery electrolyte is both corrosive and toxic, and can damage a wide range of materials if left.

Your vehicle is fitted with a low maintenance battery.

In hot climates more frequent checks of the battery electrolyte level and condition are required. If necessary, the battery cells can be topped up using distilled water.

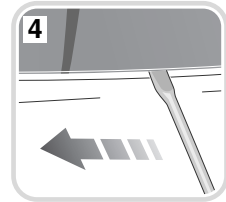
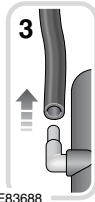
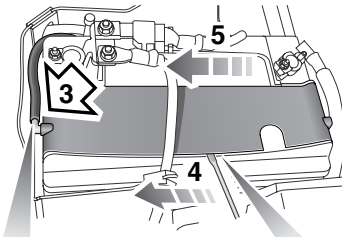
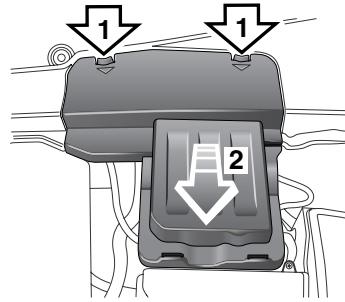

E83688

1. Press the clips to release the back of the cover.
2. Slide the cover forward, and lift it off.
3. Disconnect the vent tube.
4. Pry up the inner cover using a screwdriver blade or similar blunt implement. Run the screwdriver forward to release the inner cover edge.
5. Slide the inner cover out under the battery cable.

Vehicle battery

USING BOOSTER CABLES

Note: Before connecting booster cables ensure that the battery connections on the disabled vehicle are correct, and that all electrical equipment has been switched off.

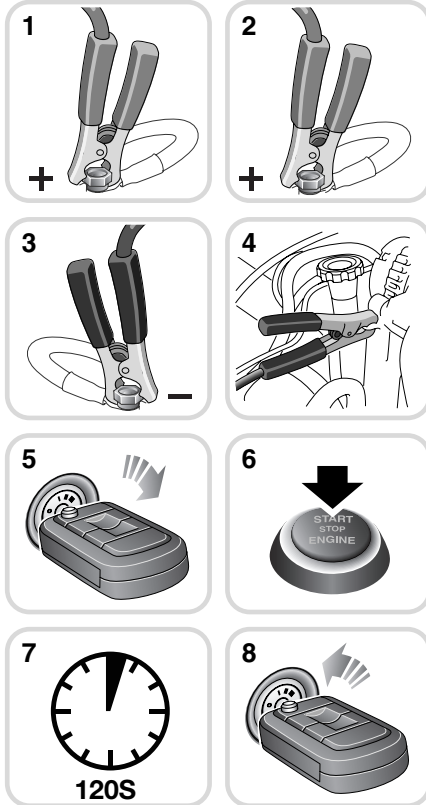

E81499

1. Connect one end of the positive booster cable to the positive terminal on the donor vehicle's battery.
2. Connect the other end of the positive booster cable to the positive terminal on the disabled vehicle's battery.

3. Connect one end of the negative booster cable to the negative terminal on the donor vehicle's battery.
4. Connect the other end of the negative booster cable to a suitable earth point on the disabled vehicle. The earth point should be at least 0.5 metres (20 inches) away from the battery, and as far as possible from any fuel or brake pipes.
 - Check that all cables are clear of any moving components, and that all four connections are secure.
5. Start the engine of the donor vehicle, and allow it to idle for a few minutes.
6. Start the engine of the disabled vehicle.
7. Allow both vehicles to idle for two minutes.
8. Switch off the donor vehicle.

Disconnecting the cables

WARNING



To avoid serious injury use extreme caution when removing the booster cables as the engine will be running on the previously disabled vehicle. This means that you will be working close to components which are moving at high speed, carry high voltage, or may be hot.

Note: Do not switch any electrical equipment on until after the cables have been disconnected.

The engine should be running on the previously disabled vehicle, and the engine switched off on the donor vehicle. Disconnect the booster cables in the exact reverse order of that used for connection.

Vehicle battery

CHARGING THE VEHICLE BATTERY

WARNINGS

 Ensure that the charger used is of the correct type and rating for the battery. Using an unsuitable charger may damage the battery, and could cause the battery to explode.

 Always charge the battery in a well ventilated area away from any naked flames, sparks or other ignition sources. During charging the battery can produce a highly explosive and flammable gas.

CAUTIONS

 The battery must be disconnected and removed from the vehicle before charging. Failure to do so could result in damage to the vehicle's electrical system.

 Always follow the instructions supplied with the battery charger. Failure to do so may result in damage to the battery.

1. Disconnect the battery and remove it from the vehicle.
2. Connect the battery charger in accordance with the charger manufacturer's instructions.
3. Once the charge is complete switch off the power to the charger.
4. Disconnect the charger cables from the battery.
5. Allow the battery to stand for an hour before connecting to the vehicle. This will allow any explosive gasses to dissipate, and reduce the risk of explosion.

CHANGING THE VEHICLE BATTERY

Disconnecting

WARNINGS

 Use caution when lifting the battery out of, or into, the vehicle. It is heavy, and may cause injury when lifting, or if dropped.

 Do not tip the battery when lifting or moving as tilting the battery more than 45 degrees may damage the battery, and may cause the electrolyte to leak out. Battery electrolyte is highly corrosive, and toxic.

CAUTIONS

 Do not rest the battery on any part of the vehicle as it may cause damage due to it's weight.

 Do not run the engine with the battery disconnected. Doing so may damage the charging system.

1. Ensure that all electrical circuits are switched off, all windows are closed, and the alarm is disarmed.
2. Remove the remote control from the vehicle and wait two minutes to allow the systems to power down fully.
3. Undo the negative clamp, and lift the cable and clamp clear of the battery terminal.
4. Undo the positive clamp, and lift the cable and clamp clear of the battery terminal.
5. Undo the battery clamp and lift the battery clear of the vehicle.

Vehicle battery

Effects of disconnecting

Disconnecting the battery can affect a number of vehicle systems, especially if there is insufficient battery power prior to disconnection. For example, the alarm may trigger depending on its state when the battery was disconnected. If the alarm does sound, use the remote control in the normal way to disarm the security system. The windows may need resetting to enable the one-shot feature to operate correctly. See **ELECTRIC WINDOWS** (page 93).

Replacement batteries

WARNING



Only fit a battery of the correct type and rating. Fitting an incorrect battery may result in a fire, or damage to the electrical system. If you are in any doubt when fitting a battery seek qualified assistance.

Battery disposal

Note: *Used batteries must be disposed of correctly as they contain a number of harmful substances. Seek advice on disposal from your Land Rover Dealer/Authorised Repairer, and/or your local authority.*

Refitting

WARNING



When refitting the battery ensure that no metal objects, or vehicle components, come into contact with the battery terminals. Metal objects can cause a spark or short circuit, both of which may result in an explosion.

CAUTIONS



Ensure that when fitting a battery to the vehicle, the terminals and battery clamps are clean, and lightly coated with petroleum jelly. This will ensure good electrical connections are made, and help to prevent corrosion.



Always follow the battery manufacturers instructions. Failure to do so may result in damage to the vehicle and/or the electrical system.

A new battery should be supplied with plastic terminal covers. Leave the covers in place when fitting the battery, and remove them one at a time to fit the battery cable clamps.

Refitting is an exact reversal of the removal procedure. If you are in any doubt about fitting a battery seek qualified assistance before attempting to fit the battery.

Wheels and tyres

GENERAL INFORMATION

Tyre markings

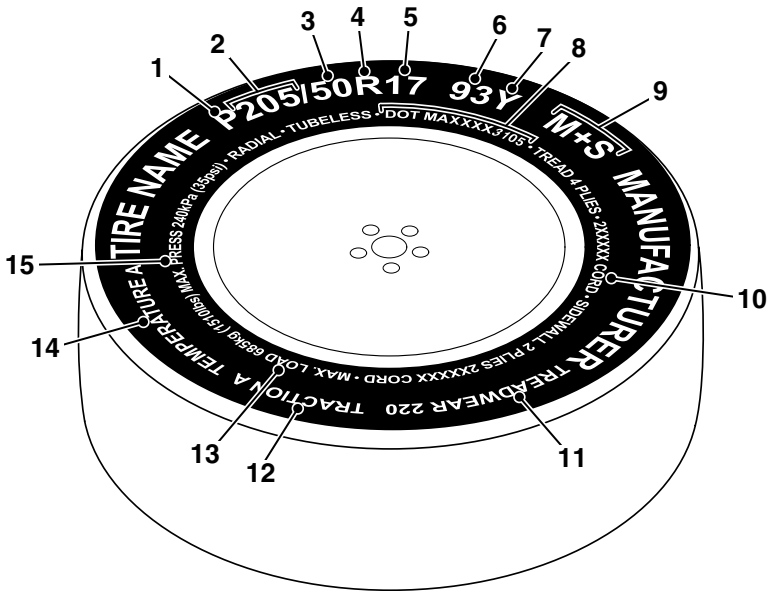

E80640

1. P indicates that the tyre is for passenger vehicle use.
2. The width of the tyre from sidewall edge to sidewall edge in millimetres.
3. The aspect ratio, also known as the profile, gives the sidewall height as a percentage of the tread width. So, if the tread width is 205 mm, and the aspect ratio is 50, the sidewall height will be 102 mm.
4. R indicates that the tyre is of Radial ply construction.
5. The diameter of the wheel rim given in inches.
6. The load index for the tyre. This index is not always shown.
7. The speed rating denotes the maximum speed at which the tyre should be used for extended periods. †
8. Tyre manufacturing standard information, which can be used for tyre recalls and other checking processes. Most of this information relates to the manufacturer, place of manufacture etc. The last four numbers are the date of manufacture. For example, if the number was 3106, the tyre was made in the 31st week of 2006.
9. M+S or M/S indicates that the tyre has been designed with some capability for mud and snow.

Wheels and tyres

10. The number of plies in both the tread area, and the sidewall area, indicates how many layers of rubber coated material make up the structure of the tyre. Information is also provided on the type of materials used.
11. Wear rate indicator. A tyre rated at 400 for example, will last twice as long as a tyre rated at 200.
12. The traction rating grades a tyres performance when stopping on a wet road surface. The higher the grade the better the braking performance. The grades from highest to lowest are, AA, A, B, and C.
13. The maximum load which can be carried by the tyre.
14. Heat resistance grading. The tyre's resistance to heat is grade A, B, or C, with A indicating the greatest resistance to heat. This grading is provided for a correctly inflated tyre, which is being used within its speed and loading limits.
15. The maximum inflation pressure for the tyre. This pressure should not be used for normal driving. See **TECHNICAL SPECIFICATIONS** (page 194).

† Speed ratings

Rating	Speed kmh (mph)
Q	160 (99)
R	170 (106)
S	180 (112)
T	190 (118)
U	200 (124)
H	210 (130)
V	240 (149)
W	270 (168)
Y	300 (186)

TYRE CARE

WARNINGS



Defective tyres are dangerous. Do not drive the vehicle if a tyre is damaged, excessively worn, or incorrectly inflated. Doing so may lead to premature tyre failure.



Avoid contaminating the tyres with vehicle fluids as they may cause damage to the tyre.



Avoid spinning the wheels. The forces released can damage the structure of the tyre, and cause it to fail. Doing so may lead to premature tyre failure.



If wheel spin is unavoidable due to a loss of traction (in deep snow for example) do not exceed the 50 km/h (30 mph) point on the speedometer. Doing so may lead to premature tyre failure.

Note: Tyre condition should be checked after the vehicle has been used off-road. As soon as the vehicle returns to a normal, hard, road surface stop the vehicle and check for damage to the tyres.

Wheels and tyres

All of the vehicle's tyres (including the spare) should be checked regularly for damage, wear and distortion. If you are in any doubt about the condition of a tyre, have it checked immediately by a tyre repair centre, or your Land Rover Dealer/Authorised repairer.

Tyre wear

Good driving practise will improve the mileage you obtain from your tyres, and avoid unnecessary damage.

- Always ensure that the tyre pressures are correctly adjusted.
- Always observe the posted speed limits, and advisory speeds for bends.
- Avoid pulling away quickly, or hard acceleration.
- Avoid making fast turns or braking sharply.
- Wherever possible, avoid potholes, or obstacles on the road.
- Do not drive up kerbs, or rub the tyres against them when parking.

Wear indicators

WARNING



Wear indicators show the minimum tread depth recommended by the manufacturers. Tyres which have worn to this point will have reduced grip and poor water displacement characteristics.

CAUTION



If tread wear is uneven across a tyre, or the tyre wears excessively, the vehicle should be checked by your Land Rover Dealer/Authorised Repairer as soon as possible.



E80236

When the tread has worn down to approximately 2 mm, wear indicators start to appear at the surface of the tread pattern. This produces a continuous band of rubber across the tread as a visual indicator.

To maintain performance and grip the tyre must be replaced as soon as the wear indicator becomes visible. Sooner, if legislation requires replacement at a greater tread depth.

Note: *Tread depth should be checked regularly, in some case more frequently than the service intervals. For advice on checking tyres contact your Land Rover Dealer/Authorised repairer, or a tyre dealer.*

Age degradation

Tyres degrade over time due to the effects of ultraviolet light, extreme temperatures, high loads, and environmental conditions. It is recommended that tyres are replaced at least every six years, but they may require replacement more frequently.

Land Rover recommends that even if unused, the spare tyre be replaced at the same time as the four road tyres.

Punctured tyres

WARNING



Do not drive the vehicle with a punctured tyre. Even if the punctured tyre has not deflated, it is unsafe to use as the tyre may deflate suddenly at any time. See **TYRE REPAIR KIT** (page 187).

Wheels and tyres

Tyre checks

Not all punctures result in the tyre deflating immediately. Therefore, it is important to check the tyres for damage and foreign objects, regularly.

When driving, if a sudden vibration, or change to the vehicle's handling is noticed, reduce speed immediately. Do not brake hard, or make any sudden manoeuvres or direction changes. Drive slowly to an area off of the main highway and stop the vehicle.

Note: *Driving the vehicle to a safe area may cause damage to the punctured tyre, but occupant safety is far more important.*

Inspect the tyres for signs of punctures, damage, or under inflation. If any damage or deformity is detected, the tyre should be replaced. If a spare tyre is not available, then the vehicle should be recovered to a tyre repair centre, or Land Rover Dealer/Approved repairer.

Note: *The tyres should be checked immediately after any off-road use, and prior to using the vehicle on a public highway.*

Replacement tyres

WARNINGS



Do not fit cross-ply tyres.



Do not fit tubed tyres.



Do not swap tyres around the vehicle.



Tyres bed in to the specific characteristics of each wheel position.

Swapping them around may affect the vehicle's handling and traction.



Always fit replacement tyres of the same type, and wherever possible of the same make and tread pattern.

WARNINGS



Replacement wheels should be genuine Land Rover parts. This will maintain the designed driving characteristics both on and off road.



If the use of tyres not recommended by Land Rover is unavoidable, ensure that you read, and fully comply with the tyre manufacturers instructions. Failure to do so may lead to tyre failure due to incorrect fitment or use.

Ideally, tyres should be replaced in sets of four. If this is not possible, replace the tyres in pairs (front and rear). When tyres are replaced, the wheels should always be re-balanced, and alignment checked.

The correct tyre specification for your vehicle can be found on the tyre information label.

Wheels and tyres

Directional tyres

Directional tyres are designed to operate correctly when rotating forwards (when the vehicle is travelling forwards).

Typical direction indicators

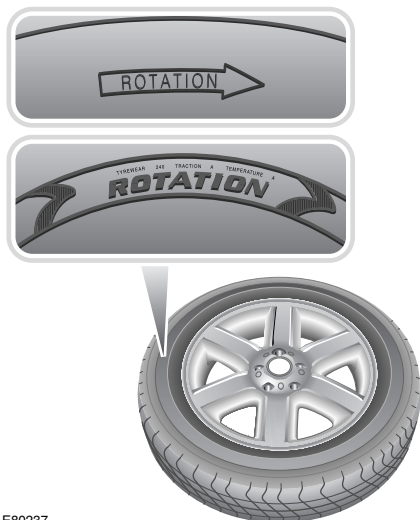



E80237

Tyre pressures

WARNINGS

 Never drive your vehicle if the tyre pressures are incorrect. Under-inflation causes excessive flexing and uneven tyre wear. This can lead to sudden tyre failure. Over-inflation causes a harsh ride, uneven tyre wear and poor handling.

 Pressure checks should only be carried out when the tyres are cold, and the vehicle has been stationary for more than three hours. A hot tyre at or below recommended cold inflation pressure is dangerously under-inflated.

 If the vehicle has been parked in strong sunlight, or used in high ambient temperatures do not reduce the tyre pressures. Move the vehicle into the shade and allow the tyres to cool before re-checking the pressures.

Tyre pressures (including the spare) should be checked at least once a week with normal on-road use, but should be checked daily if the vehicle is used off-road. Always check the tyre pressures before setting off on a long journey.

Use a reliable gauge to check the pressures when the tyres are cold. Driving as short a distance as 3 km (1 mile) can warm the tyres up sufficiently to affect the tyre pressures.

If it is necessary to check tyre pressures when the tyres are warm, you should expect the pressures to have increased by up to 30 - 40 kpa (0.3 - 0.4 bar) (4 - 6 lbf/in²). Do not reduce the tyre pressures to the cold inflation pressure under these circumstances. Allow the tyres to cool fully before adjusting the pressures.

Wheels and tyres

Checking the tyre pressures

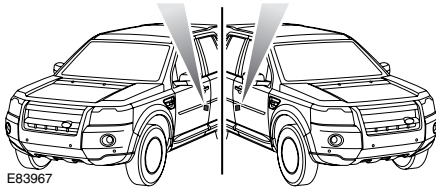
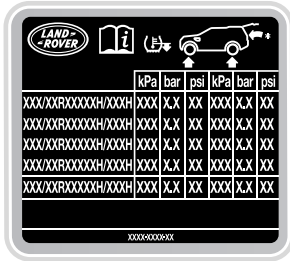

1. Tyre information label position on a left-hand drive vehicle.
2. Tyre information label position on a right-hand drive vehicle.

WARNING



Tyre pressures should be checked regularly using an accurate pressure gauge, when the tyres are cold. Failure to properly maintain your tyre pressures could increase the risk of tyre failure resulting in loss of vehicle control and personal injury.

The following procedure should be used to check and adjust the tyres pressures.

1. Remove the valve cap.
2. Firmly attach a tyre pressure gauge/inflator to the valve.
3. Read the tyre pressure from the gauge, and add air if required.
4. If air is added to the tyre, remove the gauge and re-attach it before reading the pressure. Failure to do so may result in an inaccurate reading.

5. If the tyre pressure is too high, remove the gauge and allow air out of the tyre by pressing the centre of the valve. Refit the gauge to the valve and check the pressure.
6. Repeat the process adding or removing air as required until the correct tyre pressure is reached.
7. Refit the valve cap.

Note: It is an offence in certain countries to drive a vehicle with incorrect tyre pressures.

Note: It is the driver's responsibility to ensure that the tyre pressures are correct.

Tyre valves

Keep the valve caps screwed down firmly to prevent water or dirt entering the valve. Check the valves for leaks when checking the tyre pressures.

Wheels and tyres

Pressure compensation for ambient temperature changes

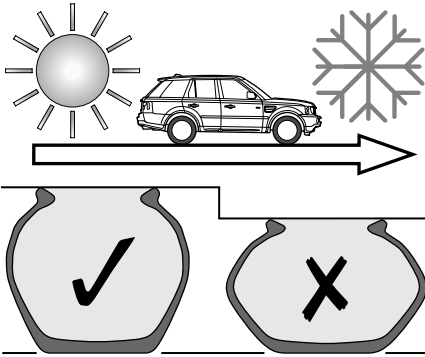

E80321

If the ambient temperature drops, the tyre pressures will decrease, which may cause under inflation. This should be borne in mind when travelling to, or through, areas of lower temperature.

Under inflation causes the tyre side wall height to reduce, which in turn results in uneven tyre wear, and a risk of tyre failure.

Tyre pressures may be adjusted before setting off on a journey to, or through, areas of low temperature. Alternatively, the tyre pressures can be adjusted when low temperature areas are reached.

Note: *If the tyre pressures are to be adjusted in the lower temperature area, the vehicle should be left standing for at least one hour prior to adjustment.*

Tyre pressures should be increased by 0.14 bar/14 kPa (2 lbf/in²) for each 10 °C (20 °F) temperature decrease.

Flat spots

If the vehicle is stationary for a long period when the ambient temperature is high, the tyres may form flat spots. When the vehicle is driven these flat spots will cause a vibration which will steadily disappear as the tyres warm up and regain their original shape.

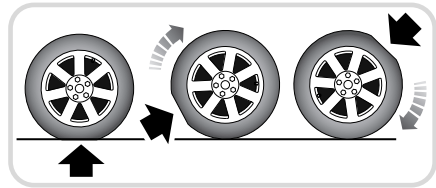
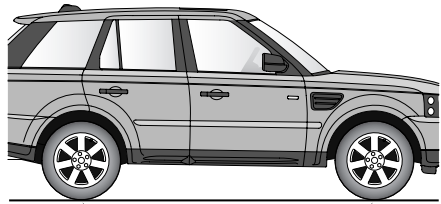

E80322

In order to minimise flat spotting, the tyre pressures can be increased.

Tyre pressures should be increased by 0.14 bar/14 kPa (2 lbf/in²) for each 10 °C (20 °F) temperature increase above 20 °C (68 °F).

Long term storage

Flat spotting can be minimised during long term storage by increasing the tyre pressures to the maximum indicated on the tyre sidewall.

Note: *The tyre pressures should be reduced to the correct pressure before the vehicle is driven.*

Wheels and tyres

USING WINTER TYRES

If winter tyres are fitted to the vehicle, the tyre manufacturers instructions should be followed. Pay particular attention to instructions regarding the maximum speed that the vehicle can be driven, and the correct pressures for the tyres.

CHANGING A ROAD WHEEL

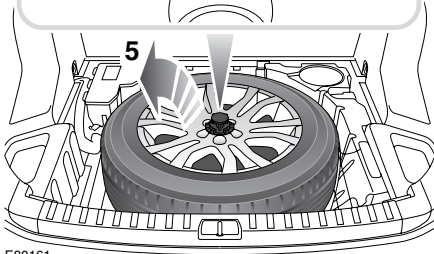
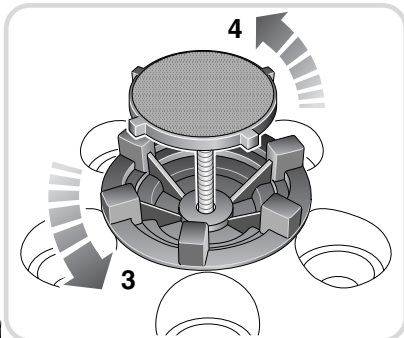
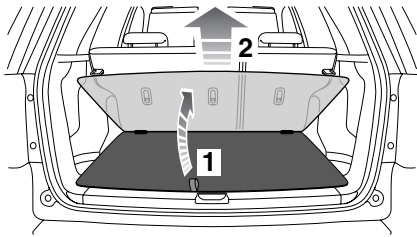

E80161

To access the spare wheel and tool kit :-

1. Lift the floor panel.

2. Pull the floor panel towards the rear of the vehicle and remove it from the vehicle.
3. Slacken the spare wheel locking ring.
4. Undo and remove the retaining bolt.
5. Remove the spare wheel.
6. Remove the tool kit.

WARNINGS

 The spare wheel is heavy and if handled incorrectly may cause injury. Use extreme caution when lifting or manoeuvring the wheels.

 Always secure the spare wheel, or the removed wheel, in the correct position using the retaining bolt. Failure to do so may cause the spare wheel to move in the event of a sudden manoeuvre or accident, leading to death or serious injury.

 Ensure that the floor panel is placed where it cannot fall and cause injury when it is removed from the vehicle.

 When removing or replacing the floor panel ensure that fingers and hands are kept clear. Failure to do so may result in crush injuries.













Note: When replacing the spare wheel ensure that the retaining bolt is screwed fully home before tightening the clamping ring.

Wheels and tyres





Wheel changing safety

Before raising the vehicle, or changing a wheel ensure that you read, and comply with the following warnings.

WARNINGS

-  Always find a safe place to stop, off of the highway and away from traffic.
-  Ensure that the vehicle is on firm level ground.
-  Disconnect trailer/caravan from vehicle.
-  Switch on the hazard warning lamps.
-  Ensure that all passengers, and animals, are out of the vehicle, and in a safe place away from the highway.
-  Place a warning triangle at a suitable distance behind the vehicle, facing towards oncoming traffic.
-  Ensure that the front wheels are in the straight ahead position, and engage the steering lock.
-  Apply the parking brake, and engage Park in vehicles fitted with an automatic transmission.
-  Apply the parking brake, and engage 1st or reverse gear in vehicles fitted with a manual transmission.
-  Ensure that the jack is on firm level ground.
-  Never place anything between the jack and the ground, or the jack and the vehicle.
-  Always chock the wheels using suitable wheel chocks. Place the chocks on both sides of the wheel diagonally opposite the wheel to be changed.

WARNINGS

-  If jacking the vehicle on a slight slope is unavoidable, place the chocks on the downhill side of the two opposite wheels.
 -  Take care when lifting the spare wheel, and removing the punctured wheel. The wheels are heavy, and can cause injuries if not handled correctly.
 -  Remove the spare wheel prior to jacking the vehicle. To avoid destabilising the vehicle when raised.
 -  Take care when loosening the wheel nuts. The wheel brace may slip off if not properly attached, and the wheel nuts may give way suddenly. Either unexpected movement may cause an injury.
-

Wheels and tyres

Positioning the jack

WARNINGS

 Never work beneath the vehicle, or place any part of your body beneath the vehicle with the jack as the only means of support. Always use suitable vehicle support stands which are approved for the weight of the vehicle.

 Ensure that the jack is correctly located onto the jacking point.

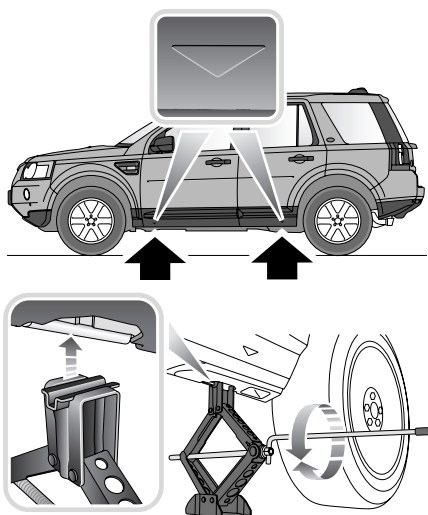

E80178

1. Read and observe the warnings in **Wheel changing safety**.
2. Loosen the wheel nuts half a turn (anti-clockwise).
3. Position the jack beneath the relevant jacking point.
4. Raise the vehicle using the jack with a slow steady operation. Avoid rapid, jerky actions as they may cause the vehicle/jack to become unstable.

5. Remove the wheel nuts and place them together where they cannot roll away.
6. Remove the wheel and place to one side. Do not lay the wheel on its face, as this may damage the finish.
7. Re-fit the wheel nuts, and lightly tighten them. Ensure that the wheel is making contact with the hub evenly.
8. Ensure that the space under the vehicle is clear of obstructions, and lower the vehicle slowly and smoothly.
9. With all wheels on the ground and the jack removed, fully tighten the wheel nuts. The wheel nuts should be tightened in sequence to the correct torque of 133 Nm (98 lb.ft).
10. If an alloy spare wheel is to be fitted, using a suitable blunt tool, knock the centre cap out of the removed wheel. Using hand pressure only, press the centre cap into the newly fitted spare.
11. Check and adjust the tyre pressure as soon as possible.

Wheels and tyres

Wheel nut tightening sequence

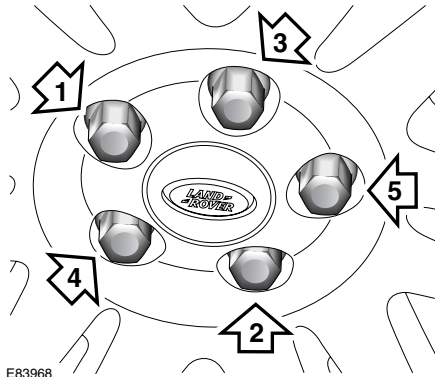

E83968

With all wheels on the ground and the jack removed, fully tighten the wheel nuts in the sequence shown to 133 Nm (98 lb.ft).

Note: If it is not possible to torque the wheel nuts when a wheel is replaced, the wheel nuts should be set to the correct torque as soon as possible.

Temporary spare wheel

WARNINGS



Please note the temporary spare warning label affixed to the wheel, and adhere to the instructions. Failure to comply with the instructions may result in incorrect use of the temporary spare wheel. Which may in turn cause vehicle instability and/or tyre failure.



Drive with caution while the temporary spare wheel is fitted, and ensure that an original size wheel and tyre are fitted as soon as possible.



Do not fit more than one temporary spare wheel.



Do not exceed 80 km/h (50 mph) while the temporary spare wheel is fitted.

WARNINGS



DSC must be switched on while the temporary spare wheel is in use.

Tool kit

Tool kit contents

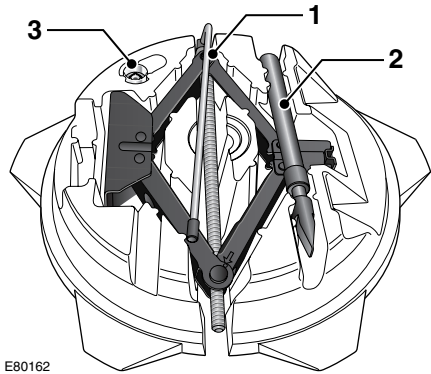

E80162

1. Jack.
2. Wheel brace.
3. Locking wheel nut adapter.

WARNING



After use the tool kit should be returned to the under floor storage area, and correctly stowed. Do not leave the tool kit, or it's components, loose in the storage area as they can prove hazardous during an impact or sudden manoeuvre.

Note: The jack requires occasional maintenance. Examine the jack for wear, damage, or corrosion, and lubricate the moving parts.

Wheels and tyres

Locking wheel nuts

Locking wheel nuts can only be removed using the special adapter provided in the tool kit.

Note: When the vehicle is first supplied the adapter may be stored in the glove compartment. It should be removed and stored in the tool kit as soon as possible.

Note: A code number is stamped onto the underside of the adapter. This number must be recorded on the security card supplied with the literature pack. If a replacement adapter is required you will be asked to quote this number. The security card must be kept safe, but should not be kept with the vehicle.

Releasing locking wheel nuts

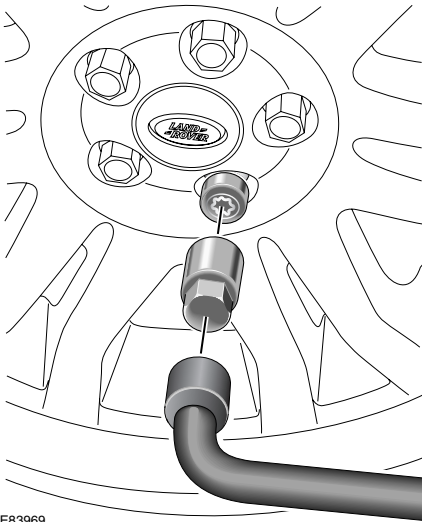

E83969

1. Insert the wheel nut adapter into the locking wheel nut ensuring that it is fully engaged.
2. Using the wheel brace, unscrew the wheel nut and adapter.

Note: After use store the wheel nut adapter correctly in the tool kit.

TYRE REPAIR KIT

WARNINGS

 To ensure vehicle safety, it is essential that you read and understand the following information. Failure to follow the instructions given here may lead to serious tyre damage, and may result in death or serious injury.

 If you are in any doubt regarding your ability to carry out the instructions, contact your Land Rover Dealer/Approved repairer before attempting the repair.

Your vehicle may not be equipped with a spare tyre. If this is the case, in its place you will find a Land Rover tyre repair kit. The Land Rover tyre repair kit can be used to repair one tyre, and it is essential that you read the following guide before attempting to repair a tyre.

The Land Rover tyre repair kit seals most punctures caused by nails, or similar items, with a maximum diameter of 6 mm (1/4 inch).

Wheels and tyres

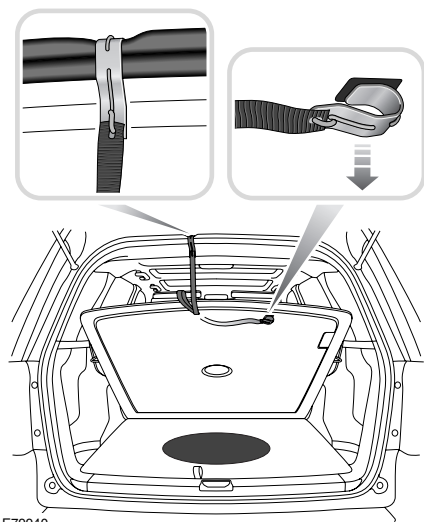

E79940

The tyre repair kit is located in the rear underfloor storage compartment.

Note: The sealant used in the tyre repair kit has a shelf life, and the expiry date is shown on the top of the bottle. Ensure that the bottle is replaced before the expiry date.

Land Rover tyre repair kit safety information

WARNINGS

 Some tyre damage may only be partially sealed, or may not seal at all, depending on the amount and type of damage. Any loss of tyre pressure can seriously affect vehicle safety.

 Do not use the tyre repair kit if the tyre has been damaged by driving while under inflated.

 Only use the tyre repair kit to seal damage located within the tyre tread area.

WARNINGS

-  Do not use the tyre repair kit to seal damage to the tyre sidewall.
-  Do not exceed 80 km/h (50 mph) when a repaired tyre is fitted to the vehicle.
-  The maximum distance that should be driven when a repaired tyre is fitted, is 200km (125 miles).
-  When a repaired tyre is fitted, drive with caution and avoid sudden braking or steering manoeuvres.
-  Only use the tyre repair kit for the vehicle with which it was supplied.
-  Do not use the tyre repair kit for any other purpose than tyre repair.
-  Never leave the tyre repair kit unattended when in use.
-  Only use the tyre repair kit within the -30 °C to +70 °C temperature range.
-  Always keep children and animals at a safe distance from the tyre repair kit when in use.
-  Do not stand directly beside the compressor when it is operating.
-  Check the tyre sidewall prior to inflation. If any cracks, damage, or deformities are apparent do not inflate the tyre.
-  Watch the tyre sidewall during inflation. If any cracks, damage, or deformities are apparent switch off the compressor, and deflate the tyre.

Wheels and tyres

Land Rover tyre repair kit

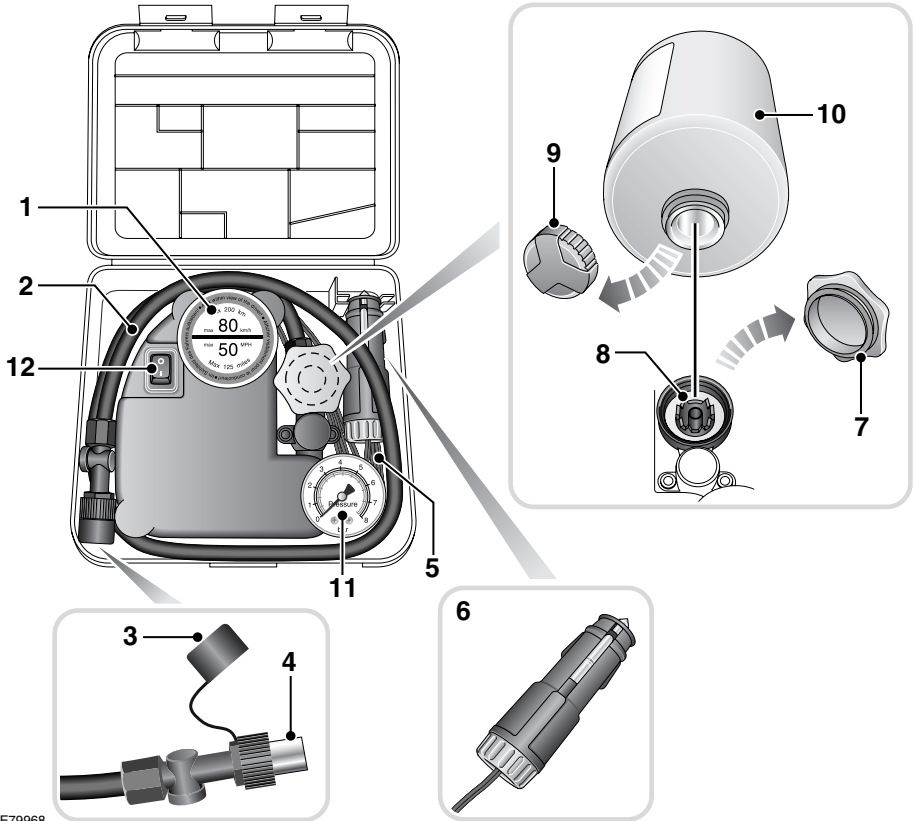

E79968

1. Maximum speed label. 80 km/h (50 mph).
2. Tyre inflation hose.
3. Inflation hose protective cap.
4. Inflation hose connector.
5. Compressor power cable.
6. Power cable connector.
7. Sealant bottle receiver cap (orange).
8. Sealant bottle receiver.
9. Sealant bottle cap.
10. Sealant bottle.
11. Tyre pressure gauge.
12. Compressor on/off switch. (I = on. 0 = off.)

Wheels and tyres

Using the Land Rover tyre repair kit

WARNINGS



Avoid skin contact with the sealant which contains natural rubber latex.

Do not unscrew the sealant bottle from the receiver until it is empty, as sealant will leak out.



If the tyre inflation pressure does not reach 1.8 bar (26 lb/in²) within seven minutes, the tyre may have suffered excessive damage. A temporary repair will not be possible, and the vehicle should not be driven until the tyre has been replaced.

CAUTIONS



Before attempting a tyre repair, ensure that the vehicle is parked safely, as far away from passing traffic as possible.



Ensure that the parking brake is applied, and P is selected if an automatic transmission is fitted.



Do not attempt to remove foreign objects such as nails, screws, etc from the tyre.



Always run the engine when using the compressor, unless the vehicle is in an enclosed, or poorly ventilated space.



To prevent overheating do not operate the compressor continuously for longer than ten minutes.

Note: All vehicle drivers and occupants should be made aware that a temporary repair has been made to a tyre fitted to the vehicle. They should also be made aware of the special driving conditions imposed when using a repaired tyre.

Repair procedure

1. Open the tyre repair kit and peel off the maximum speed label. Attach the label to the fascia in the driver's field of view. Take care not to obstruct any of the instruments or warning lights.
2. Uncoil the compressor power cable and the inflation hose.
3. Unscrew the orange cap from the sealant bottle receiver, and the sealant bottle cap.
4. Screw the sealant bottle into the receiver (clockwise) until tight.
 - Screwing the bottle onto the receiver will pierce the bottle's seal. Do not unscrew a full, or partly used bottle from the receiver. Doing so will result in the sealant leaking from the bottle.
5. Remove the valve cap from the damaged tyre.
6. Remove the protective cap from the inflation hose, and connect the inflation hose to the tyre valve. Ensure that the hose is screwed on firmly.
7. Ensure that the compressor switch is in the off (O) position.
8. Insert the power cable connector into an auxiliary power socket. See **AUXILIARY POWER SOCKETS** (page 110).
9. Unless the vehicle is in an enclosed or poorly ventilated area, start the engine.
10. Set the compressor switch to the on (I) position.
11. Inflate the tyre to a minimum of 1.8 bar (26 lb/in²) and a maximum of 3.5 bar (51 lb/in²).[†]

Wheels and tyres

12. During the inflation, switch the compressor off briefly to check the tyre pressure using the gauge mounted on the compressor.
 - It should not take longer than seven minutes to inflate the tyre. If after seven minutes the tyre has not reached the minimum pressure, the tyre should not be used.
13. Once the tyre has been inflated switch off the compressor. If desired the engine may be turned off after the compressor has been turned off.
14. Remove the power connector from the auxiliary power socket.
15. Remove the inflation hose from the tyre valve by unscrewing it as quickly as possible (anti-clockwise).
16. Replace the inflation hose protective cap, and the tyre valve cap.
17. Do not remove the sealant bottle from the receiver.
18. Ensure that the tyre repair kit (including the bottle, and receiver caps) are placed securely in the vehicle. You will need to use the kit to check the tyre pressure after 3km (2 miles) so ensure they are easily accessible.
19. Immediately drive the vehicle for 3 km (2 miles) to allow the sealant to coat the inner surface of the tyre and form a seal at the puncture.

†When pumping the sealant through the tyre valve, the pressure may rise up to 6 bar (87 lb/in²). The pressure will drop again after approximately 30 seconds.

Checking the tyre pressure after a repair

WARNINGS



When driving the vehicle, if you experience vibrations, abnormal steering, or noises, reduce speed immediately. Drive with extreme caution and reduced speed to the first safe place to stop the vehicle. Visually examine the tyre, and check it's pressure. If there are any signs of damage or deformity to the tyre, or the tyre pressure is below 1.3 bar (19 lb/in²) do not continue driving.



Consult a tyre repair centre, or your Land Rover Dealer/Authorised repairer for advice concerning the replacement of a tyre after using a tyre repair kit.

1. Drive the vehicle for 3 km (2 miles) then stop in a safe place. Carry out a visual examination of the tyres condition.
2. Remove the protective cap from the inflation hose.
3. Screw the inflation hose connector firmly onto the tyre valve.
4. Read the tyre pressure from the gauge.
5. If the pressure of the sealant filled tyre is above 1.3 bar (19 lb/in²) adjust the pressure to the correct value. See **TECHNICAL SPECIFICATIONS** (page 194).
6. Ensure that the compressor switch is in the off position (**O**), and insert the power cable connector into an auxiliary power socket. See **AUXILIARY POWER SOCKETS** (page 110).
7. If the vehicle is in a well ventilated area, start the engine.
8. Switch on the compressor (**I**), and inflate the tyre to the correct pressure.

Wheels and tyres

9. To check the tyre pressure turn off the compressor then read the pressure from the gauge.
10. When the compressor is off, if the tyre pressure is too high, release the required amount of pressure using the pressure relief valve.
11. Once the tyre is inflated to the correct pressure, switch off the compressor and remove the power plug from the auxiliary socket.
12. Unscrew the inflation hose connector from the tyre valve, replace the tyre valve cap and the inflation hose connector protective cap.
13. Do not remove the sealant bottle from the receiver.
14. Ensure that the tyre repair kit (including the bottle, and receiver caps) are placed securely in the vehicle.
15. Drive to the nearest tyre repair centre, or Land Rover Dealer/Authorised repairer for a replacement tyre to be fitted. Ensure that you make the repair centre aware that the tyre repair kit has been used before the tyre is removed.
16. Both the tyre inflation hose, and the sealant bottle should be replaced once a new tyre has been fitted.



Only sealant bottles which are completely empty should be disposed of with normal household waste. Sealant bottles which contain some sealant, and the tyre inflation hose, should be disposed of by a tyre specialist, or your Land Rover Dealer/Authorised repairer in compliance with local waste disposal regulations.

USING SNOW CHAINS

WARNING



Only use traction devices in heavy snow conditions, on hard road surfaces.

Dynamic Stability Control (DSC) must be switched off when using traction devices. DSC limits wheel spin which is required to maintain traction in deep snow conditions.

Never exceed 50 km/h (30 mph) when traction devices are fitted.

Never fit traction devices to a temporary use spare wheel.

Land Rover approved traction devices may be used to improve traction on a hard road surface in heavy snow conditions. They should not be used in off-road conditions.

If it becomes necessary to fit traction devices, the following points should be observed:-

- Single sided Spike-spyder traction devices can only be fitted to the front wheels of vehicles fitted with 17 or 18 inch diameter wheels.
- The wheels and tyres fitted must conform to the specifications of the original equipment.
- No traction devices should be fitted to the rear wheels.
- Only Land Rover approved traction devices should be used on the vehicle. Only Land Rover approved traction devices have been tested to ensure that they do not cause damage to the vehicle. Contact your Land Rover Dealer/Authorised repairer for information.
- Always read, understand, and follow the snow chain manufacturer's instructions. Pay particular attention to the maximum speed, and fitting instructions.

Wheels and tyres

- Avoid tyre/vehicle damage by removing the traction devices as soon as the conditions allow.

TYRE GLOSSARY

Terms used

lbf/in² or psi

Pounds per square inch, an imperial unit of measure for pressure.

kPa

Kilo Pascal, a metric unit of measure for pressure.

Cold tyre pressure

The air pressure in a tyre which has been standing in excess of three hours, or driven for less than one mile.

Maximum inflation pressure

The maximum pressure to which the tyre should be inflated. This pressure is given on the tyre side wall in lbf/in² (psi) and kPa.

***Note:** This pressure is the maximum allowed by the tyre manufacturer. It is not the pressure recommended for use. See **TECHNICAL SPECIFICATIONS** (page 194).*

Kerb weight

The weight of a standard vehicle, including a full tank of fuel, any optional equipment fitted, and with the correct coolant and oil levels.

Gross vehicle weight

The maximum permissible weight of a vehicle with driver, passengers, load, luggage, equipment, and towbar load.

Accessory weight

The combined weight (in excess of those items replaced) of items available as factory installed equipment.

Production options weight

The combined weight of options installed which weigh in excess of 1.4 kg (3 lb) more than the standard items that they replaced, and are not already considered in kerb or accessory weights. Items such as heavy duty brakes, high capacity battery, special trim etc.

Vehicle capacity weight

The number of seats multiplied by 68 kg (150 lb) plus the rated amount of load/luggage.

Maximum loaded vehicle weight

The sum of kerb weight, accessory weight, vehicle capacity weight, plus any production option weights.

Rim

The metal support for a tyre, or tyre and tube, upon which the tyre beads are seated.

Bead

The inner edge of a tyre that is shaped to fit to the rim and form an air tight seal. The bead is constructed of steel wires which are wrapped, or reinforced, by the ply cords.

Wheels and tyres

TECHNICAL SPECIFICATIONS

Wheel size	Tyre size	Speed rating
8.0J x 18	235/60 R 18	V
7.5J x 17	235/65 R 17	V
6.5J x 16	215/75 R 16	H

Accessory wheels and tyres



1 _____ 2 _____

3 _____

E81991

Note: Use the diagram above to record accessory wheel and tyre information.

1. Front tyre pressure.
2. Rear tyre pressure.
3. Wheel and tyre information (size, speed rating, etc).

WARNING



Contact your Land Rover dealer before fitting any accessory wheels and tyres. Your Land Rover dealer will be able to offer guidance regarding the correct accessories. Fitting incorrect wheel/tyre combinations can seriously affect the ride and handling of your vehicle. In extreme cases this may lead to loss of control of the vehicle.

Fuses

FUSE BOX LOCATIONS

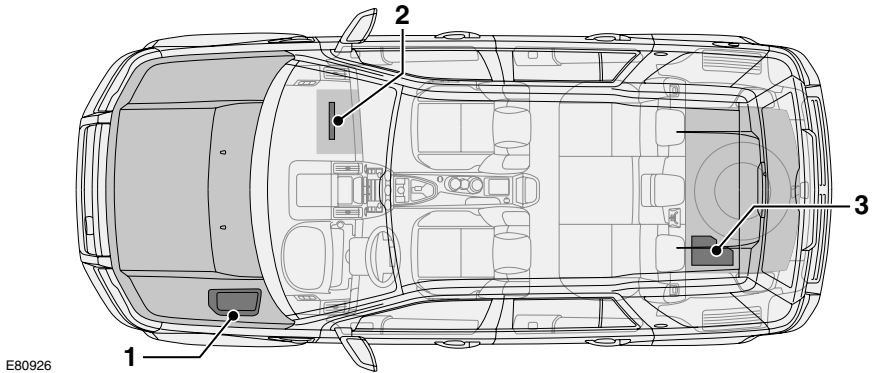

1. Engine compartment fuse box.
2. Passenger compartment fuse box.
3. Luggage compartment fuse box.

CHANGING A FUSE

CAUTIONS

! Fit Land Rover approved replacement fuses of the same rating and type, or fuses of matching specification. Using an incorrect fuse may result in damage to the vehicle's electrical system, and can result in a fire.

! If the replacement fuse blows after installation the system should be checked by your Land Rover Dealer/Authorised Repairer.

Note: Land Rover recommend that owners do not remove or replace relays. It is recommended that you seek qualified assistance in the event of a relay failure.

Always switch off the ignition, and the affected electrical circuit before replacing a fuse.

Fuses

FUSE SPECIFICATION CHART

Engine compartment fuse box

Accessing fuses

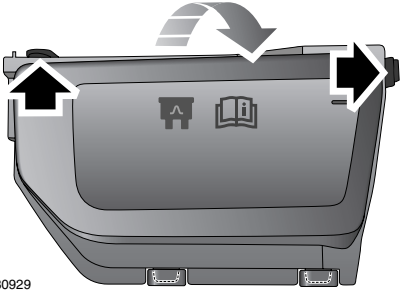

E80929

Fuse positions and specifications

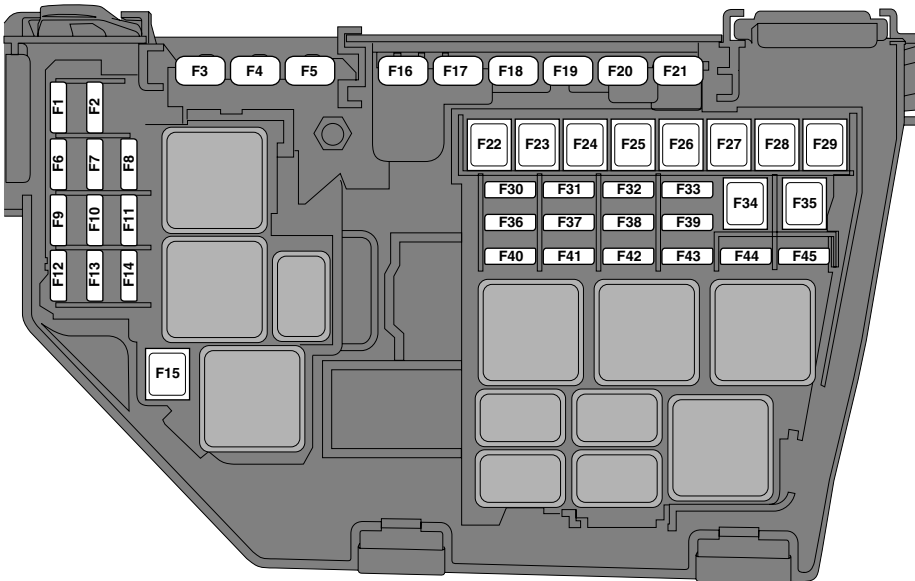

E80930

Fuses

Fuse number	Rating (Amps)	Fuse colour	Circuits protected
F1	5	tan	Glow plugs
F2	15	blue	Automatic transmission
F3	80	-	Cooling fans
F4	60	-	Glow plugs
F5	-	-	-
F6 (Diesel)	10	red	Engine management
F6 (Petrol)	15	blue	Engine management
F7	5	tan	Relays
F8 (Diesel)	10	red	Engine management
F8 (Petrol)	15	blue	Engine management
F9 (Diesel)	10	red	Engine management
F9 (Petrol)	15	blue	Engine management
F10 (Petrol)	10	red	Engine management
F11 (Diesel)	10	red	Engine management
F11 (Petrol)	10	red	Engine management
F12 (Diesel)	10	red	Engine management
F12 (Petrol)	20	yellow	Engine management
F13	15	blue	Air Conditioning
F14 (Diesel)	15	blue	Engine management
F15	40	green	Starter motor
F16 (Diesel)	100	-	Diesel PTC heater
F17	60	-	Passenger compartment fuse box supply
F18	60	-	Passenger compartment fuse box supply
F19	60	-	Luggage compartment fuse box supply
F20	60	-	Luggage compartment fuse box supply
F21	60	-	Luggage compartment fuse box supply - Audio unit
F22	30	pink	Windscreen wipers
F23	-	-	-

Fuses

Fuse number	Rating (Amps)	Fuse colour	Circuits protected
F24	30	pink	Headlamp washers
F25	30	pink	ABS
F26	40	green	ABS
F27	-	-	-
F28	40	green	Heater blower
F29	-	-	-
F30	-	-	-
F31	15	blue	Horns
F32	20	yellow	Diesel auxiliary heater
F33	5	tan	Relays
F34	40	green	Heated windscreen(LH)
F35	40	green	Heated windscreen (RH)
F36	-	-	-
F37	10	red	Heated washer jets
F38	10	red	AFS (RH lamp motors)
F39	10	red	Climate control
F40	-	-	-
F41	20	yellow	Passenger compartment fuse box supply
F42	15	blue	Engine management
F43	5	tan	Headlamp levelling control - AFS
F44	10	red	AFS (LH lamp motors)
F45	15	blue	Cigar lighter

Fuses

Passenger compartment fuse box

Accessing fuses

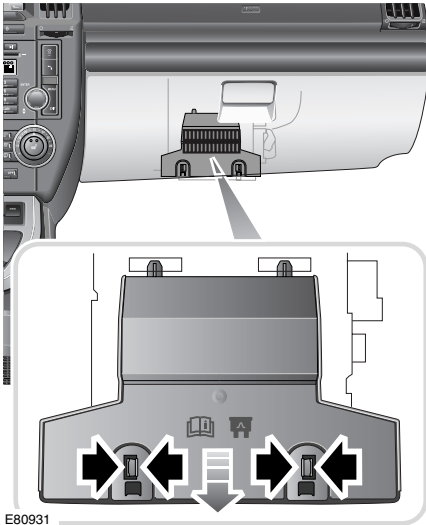

Fuse positions and specifications

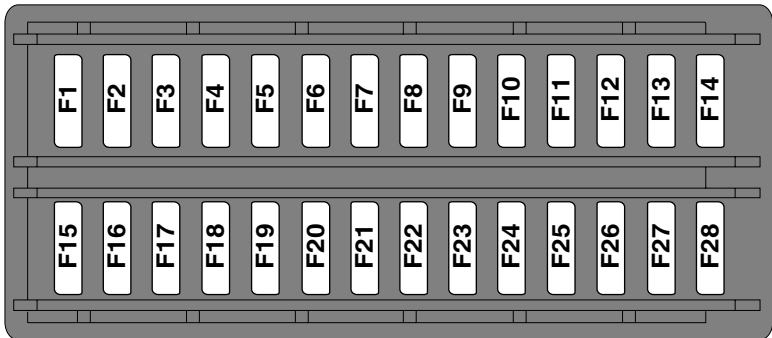

E80932

Fuses

Fuse number	Rating (Amps)	Fuse colour	Circuits protected
F1	5	tan	Rain sensor
F2	10	red	SRS
F3	5	tan	ABS
F4	5	tan	Instrument pack - Accelerator pedal - Light Switch Module
F5	-	-	-
F6	15	blue	Audio unit
F7	7.5	brown	Steering wheel controls
F8	5	tan	Instrument pack
F9	15	blue	Headlamp main beam
F10	15	blue	Sunroof
F11	7.5	brown	Reverse lights and interior mirror dip
F12	-	-	-
F13	15	blue	Front fog lamps
F14	15	blue	Screen wash
F15	-	-	-
F16	-	-	-
F17	7.5	brown	Interior lighting
F18	-	-	-
F19	5	tan	Electric seat adjustment
F20	15	blue	Rear wiper
F21	5	tan	Alarm
F22	20	yellow	Fuel pump
F23	20	yellow	Steering column lock
F24	-	-	-
F25	10	red	Tailgate - Fuel filler flap
F26	5	tan	Diagnostic socket and alarm
F27	5	tan	Start button and climate control
F28	5	tan	Brake lights

Fuses

Luggage compartment fuse box

Accessing fuses

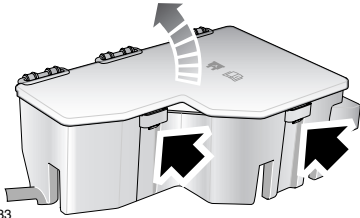
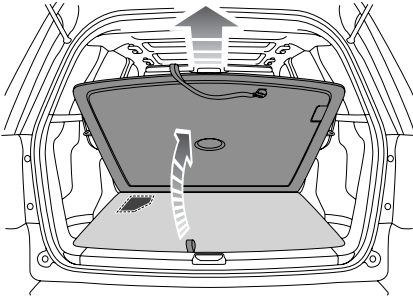

E80933

Fuse positions and specifications

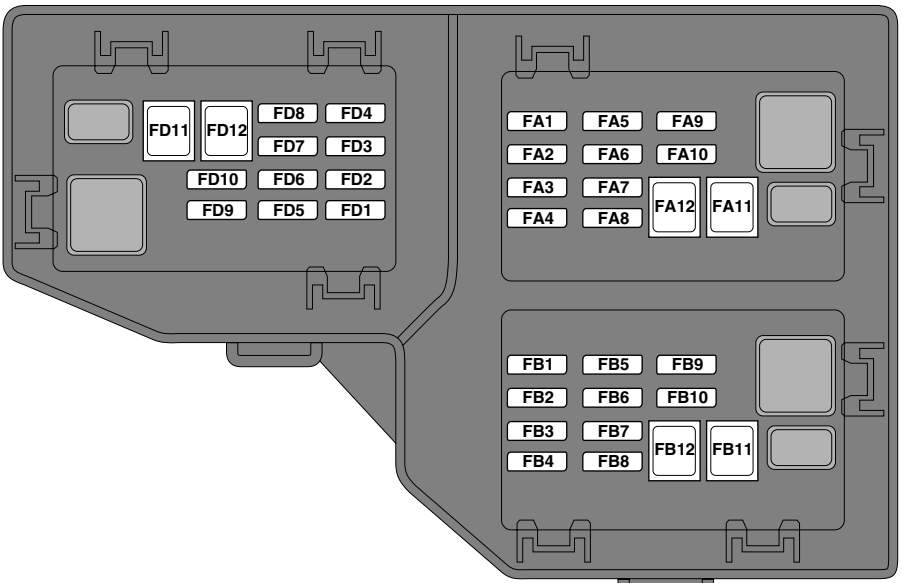

Fuses

Fuse number	Rating (Amps)	Fuse colour	Circuits protected
FA1	25	clear	Driver door controls
FA2	25	clear	Passenger door controls
FA3	25	clear	Rear left door controls
FA4	25	clear	Rear right door controls
FA5	-	-	-
FA6	15	blue	Rear accessory socket
FA7	30	green	Heated rear screen
FA8	-	-	-
FA9	15	blue	Trailer power
FA10	30	green	Driver electric seat
FA11	40	green	Trailer power
FA12	-	-	-
FB1	10	red	Park distance control
FB2	-	-	-
FB3	15	blue	Driver's seat heater
FB4	15	blue	Front passenger's seat heater
FB5	15	blue	Caravan fridge
FB6	15	blue	Electronic centre differential
FB7	-	-	-
FB8	-	-	-
FB9	30	green	Passenger electric seat
FB10	-	-	-
FB11	-	-	-
FB12	-	-	-
FD1	10	red	Audio system and touch screen
FD2	-	-	-
FD3	10	red	DAB
FD4	5	tan	Bluetooth telephone
FD5	-	-	-
FD6	10	red	Audio unit

Fuses

Fuse number	Rating (Amps)	Fuse colour	Circuits protected
FD7	-	-	-
FD8	-	-	-
FD9	30	green	Audio amplifier
FD10	-	-	-
FD11	-	-	-
FD12	-	-	-

Emergency equipment

HAZARD WARNING FLASHERS

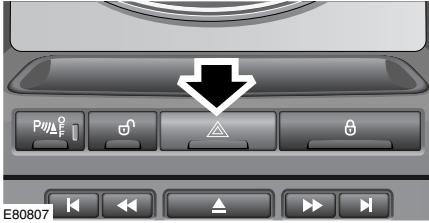

If the vehicle is stationary in an unsafe location, or may cause a hazard to other road users, switch on the hazard warning flashers. Press the switch to turn the hazard warning lamps on.

Note: Hazard warning lamps can be used when the ignition is on or off.

WARNING TRIANGLE

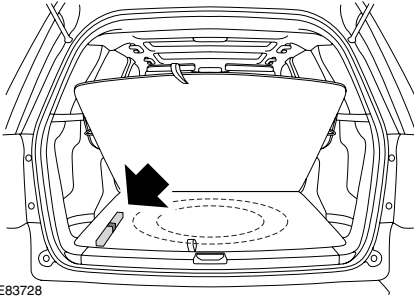

1. The warning triangle is located on the left-hand side of the under-floor storage area.

Status after a collision

DRIVING AFTER A COLLISION

Before starting or driving

WARNING



If the vehicle is involved in a collision it should be checked by a Land Rover Dealer/Authorised repairer, or suitably qualified persons before starting or driving.

If the vehicle has been involved in an accident it should be checked thoroughly before attempting to start the engine or drive the vehicle.

Check for :-

- Fuel leaks.
- Fluid leaks.
- Battery damage.
- Damage to wiring.
- Damage to lights.
- Damage to steering, suspension, wheels or tyres.
- Sharp or protruding bodywork.
- Operation of doors and locks.
- Condition and operation of seat belts and SRS components.
- Condition of child seats and their mounting/attachment points.

Note: This list is not exhaustive.

Resetting the fuel cut-off

WARNING



The fuel cut-off should never be reset if you can smell fuel, or a leak can be seen. Doing so can lead to a fire which may cause personal injury or death.

The fuel system cut-off forms part of the Safety and Restraint System (SRS) fitted to your vehicle. Following an impact, and depending on the severity, the fuel pump may be switched off.

1. Switch the ignition off, and wait for one minute.
2. Turn the ignition on for 30 seconds.
3. Check the vehicle thoroughly for fuel leaks. If a leak is detected switch the ignition off immediately.
 - The vehicle must not be started if a leak is present. Seek qualified advice, and have the vehicle recovered.
4. If no leaks are detected, start the vehicle.

When driving

When driving a vehicle which has been involved in a collision use caution and pay extra attention to the operation of the vehicle. If any changes in vehicle operation after the collision are noted when compared to it's operation before the collision, do not continue to drive the vehicle. Stop the vehicle as soon as it is safe to do so, and have the vehicle recovered.

Pay particular attention to changes in :-

- Steering.
- Braking.
- Unusual noises.
- Warning lights or messages displayed.
- Problems with electrical systems.

Status after a collision

INSPECTING SAFETY SYSTEM COMPONENTS

Following a collision the seat belt and Supplementary Restraint System components should be inspected for damage and/or deformity. The inspection and any subsequent repair work should only be carried out by a Land Rover Dealer/Authorised Repairer, or other suitably qualified persons.

Components which require inspection include :-

- Seat belt webbing and mechanisms.
- Seat belt pre-tensioners.
- Airbag covers and modules.
- Seat frames and mounting points.
- Child seats.
- Child seat anchor points.

Note: *This list is not exhaustive.*

In addition to the physical items checked the electronic control system and it's associated wiring should also be checked thoroughly. This process will include a diagnostic check which can only be carried out by a Land Rover Dealer/Authorised repairer or suitably qualified and equipped persons.

WARNING



It is not recommended that the vehicle be driven or used until all of the occupant protection systems have been checked.

Vehicle recovery

TOWING POINTS

Front and rear towing eyes

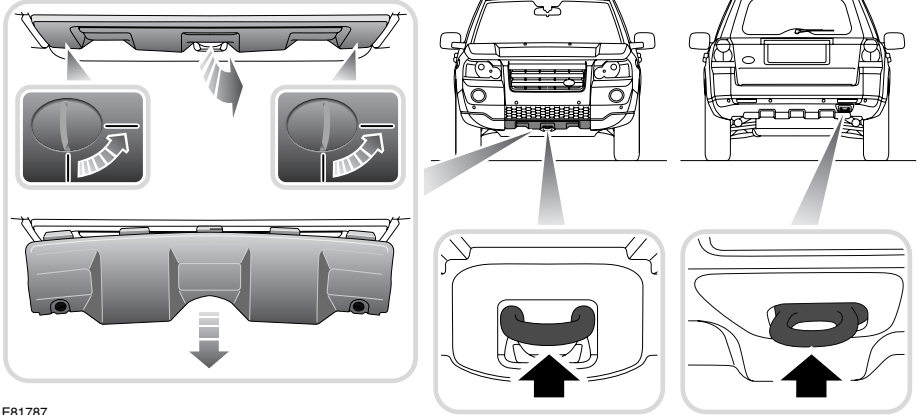

E81787

WARNINGS

 The towing eyes at the front and rear of the vehicle are designed for on-road recovery only. If they are used for any other purpose it may result in vehicle damage and serious injury.

 Never use the towing eyes to tow a trailer, caravan etc. Doing so may result in vehicle damage and serious injury.

CAUTION

 Remove the front towing eye cover before driving off-road to prevent damage or loss.

Vehicle recovery

LASHING POINTS

WARNING

 The front and rear lashing points must only be used for securing the vehicle during transportation. Use for any other purpose may result in damage to the vehicle, and serious injury.

Front

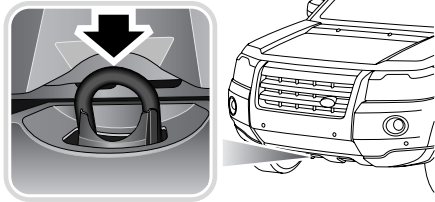

E81780

Rear

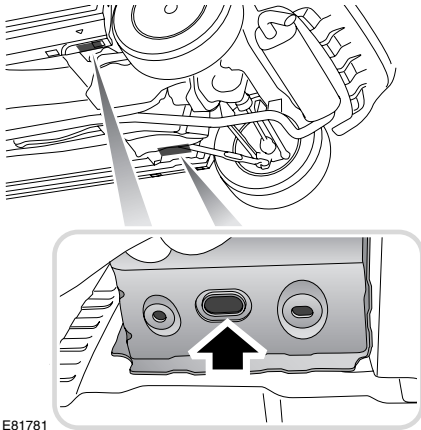

E81781

TRANSPORTING THE VEHICLE

The recommended method for recovery/transportation or the vehicle is on a transporter or trailer designed for that purpose. Ensure that transportation is carried out by suitably qualified persons, and that the vehicle is secured correctly.

TOWING THE VEHICLE ON FOUR WHEELS

WARNINGS

 Ensure that the remote control remains docked whilst the vehicle is being towed. Removing the remote control will engage the steering lock, which will prevent the vehicle from steering correctly.

 If the engine cannot be run whilst the vehicle is being towed, there will be no power assistance for the steering or brakes. This will result in greater effort being required to steer or slow the vehicle, and greatly increased stopping distances.

CAUTIONS

 The vehicle should only be towed in a forward direction with all four wheels on the ground. Towing in a reverse direction with two wheels on the ground will result in serious damage to the transmission.

 The vehicle should only be towed for a maximum of 80 km (50 miles), at a maximum speed of 80 km/h (50 mph). Towing for a greater distance, or at a higher speed may result in serious damage to the transmission.

Note: *The recommended recovery method is to raise all four wheels.*

Towing procedure

1. The vehicle should be parked on firm level ground, with the park brake on, and the gear selector in P if an automatic gearbox is fitted.
2. Secure the towing attachment from the recovery vehicle to the front towing eye. See **TOWING POINTS** (page 207).
3. Dock the remote control, and switch on the ignition. See **GENERAL INFORMATION** (page 113).

Vehicle recovery

CAUTION

 Leaving the ignition switched on for extended periods will cause the battery to drain.

4. Apply the foot brake, and select neutral.
5. With the footbrake still applied, release the park brake.
6. The vehicle can now be towed a maximum of 80 km (50 miles) at a maximum speed of 80 kmh (50 mph).
7. Upon arrival at the destination, ensure wherever possible that the vehicle is parked on firm level ground.
8. Apply the park brake, and place the selector lever into the **P** (park) position.
9. Switch off the ignition, and remove the remote control.

WARNING

 Use extreme caution when detaching towing equipment. Vehicle movement is possible which can result in serious injuries.

10. Remove the towing attachment from the towing eye.

Vehicle identification

VEHICLE IDENTIFICATION PLATE



E83693

The Vehicle Identification Number (VIN) and recommended maximum vehicle weights, are stamped on a plate rivetted to the lock side of the left-hand (right hand in China) front door aperture at the bottom. VIN should match the VIN recorded in the Service Portfolio, and the VIN visible through the front windscreen.

VEHICLE IDENTIFICATION NUMBER (VIN)

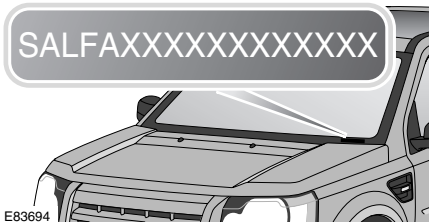

E83694

As a deterrent to thieves, and to assist the Police, the VIN is stamped on a plate which is visible through the lowest part of the left side of the windscreen.

Note: *If you need to communicate with a Land Rover Dealer/Authorised repairer, you may be asked to quote the VIN number.*

VEHICLE BUILD DATE PLATE

This is the calendar month and year in which the body and power train assemblies were conjoined and the vehicle was driven from the production line.

The vehicle built date is shown on the tyre pressure label attached to the right-hand 'B' post.

Technical specifications

ENGINE SPECIFICATIONS

Data	Petrol
Number of cylinders	6
Displacement cc's	3192
Firing order	1-5-3-6-2-4
Compression ratio	10.8:1
Power output kW (PS)	171 (233) at 6300 rpm
Maximum torque Nm	317 at 3200 rpm

Data	Diesel	Diesel with DPF
Number of cylinders	4	4
Displacement cc's	2179	2179
Firing order	1-3-4-2	1-3-4-2
Compression ratio	16.5:1	16.5:1
Power output kW (PS)	118 (160) at 4000 rpm Belgium 110 (150) at 4000 rpm	112 (152) at 4000 rpm Belgium 110 (150) at 4000 rpm
Maximum torque Nm	400 at 2000 rpm	400 at 2000 rpm

Technical specifications

WEIGHTS

Variant	Approximate unladen weight ¹	Gross Vehicle Weight (GVW) ²	Gross Train Weight ³
Petrol	1825 kg 4020 lbs	2505 kg 5520 lbs	4505 kg 9930 lbs
Diesel	1820 kg 4010 lbs	2505 kg 5520 lbs	4505 kg 9935 lbs

¹ This figure includes the tool kit, all fluids to the correct levels, and spare wheel, but excludes the driver and passengers.

² The maximum permissible weight of the vehicle including passengers and load.

³ The maximum permissible weight of the vehicle and braked trailer including their respective loads.

Variant	Maximum front axle load ¹	Maximum rear axle load ¹	Maximum roof rack load ²	Maximum payload
Petrol and Diesel	1310 kg 2885 lbs	1360 kg 2995 lbs	75 kg 165 lbs	500 kg 1100 lbs

Note: ¹ The front and rear axle maximum loads can not be reached simultaneously as this will exceed the GVW limit.

² This figure includes the weight of the roof rack.

Technical specifications

DIMENSIONS

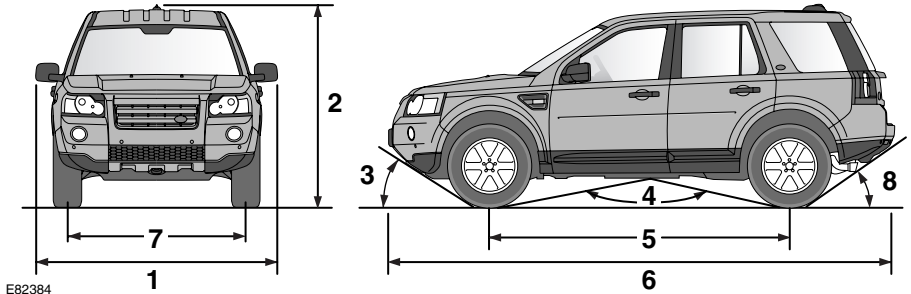

Item	Description	mm/inches	Degrees
1	Width	2180/85.7	-
1	Width with mirrors folded	2005/78.8	-
2	Maximum height (inc roof rails)	1820/71.6	-
3	Approach angle	-	31°
4	Breakover angle	-	157°
5	Wheelbase	2660/104.7	-
6	Length excluding number plate plinth	4500/177.1	-
7	Track - front	1601/63	-
7	Track - rear	1614/63.5	-
8	Departure angle without tow hitch	-	34°
8	Departure angle with detachable tow ball	-	18°
-	Turning circle (kerb to kerb)	11.3m/37.1ft	-
-	Maximum wading depth	500/19.7	-

Technical specifications

Wheel alignment data (China only)

Wheel alignment - front	Wheel alignment - rear	Camber - front	Camber - rear	Castor - front and rear
+0.30°	+0.46°	-0.5°	-1.95°	Non-adjustable

Clutch and brake pedal travel (China only)

The clutch and brake pedal travel are set at the factory and non-adjustable.

Type approval

Declarations of conformity

Declaration of Conformity appropriate to the Directive 1999/5/EC (R&TTE) Annex IV	
Visteon Deutschland GmbH Manufacturer,	
Notified Body consulted: Phoenix Test-Lab, Königswinkel 10, D-32825 Blomberg ID-Number of Notified Body: 0700	
declare under our responsibility that the product:	RKE Transmitter
Type:	TXREL
<input type="checkbox"/> Telecommunications Terminal Equipment	<input checked="" type="checkbox"/> Radio Equipment
Remote Keyless Entry System Transmitter	1
Intended Purpose	Equipment Class
complies with the appropriate essential requirements of the Article 3 of the R&TTE and the other relevant provisions, when used for its intended purpose.	
Health and Safety requirements contained in Article 3 (1) a)	
EN 60 950: 2001 Information technology equipment – Safety – Part 1: General Requirements. EN 50 371: 2002, Generic standard to demonstrate the compliance of low power electronic and electrical apparatus with the basic restrictions related to human exposure to electromagnetic fields (10 MHz – 300 GHz) – General public.	
Protection requirements with respect to electromagnetic compatibility Article 3 (1) b)	
EN 301 489-01 V.1.4.1: 08/2002, Electromagnetic Compatibility and radio spectrum Matters (ERM); Electromagnetic Compatibility (EMC) standard for radio equipment and services; Part 1: Common technical requirements. EN 301 489-03 V.1.4.1: 08/2002, Electromagnetic Compatibility and radio spectrum Matters (ERM); Electromagnetic Compatibility (EMC) standard for radio equipment and services; Part 3: Specific conditions for Short Range Devices (SRD) operating on frequencies between 9 kHz and 40 GHz.	
Means of the efficient use of the radio frequency spectrum	
<input checked="" type="checkbox"/> Air interface specification of the radio path contained in Article 3(2)	
EN 300 220-3 V1.1.1: 09/2000, Electromagnetic compatibility and Radio spectrum Matters (ERM); Short range devices (SRD); Radio equipment to be used in the 25 MHz to 1000 MHz frequency range with power levels ranging up to 500 mW; Part 3: Harmonized EN covering essential requirements under article 3.2 of the R&TTE Directive.	
Address: Visteon Deutschland GmbH Visteonstrasse 4 - 10 50170 Kerpen Germany URL: http://www.visteon.com/europe	
 Roland Greff Vice President Visteon Deutschland GmbH	

CE 0700

Type approval

SIEMENS VDO

A u t o m o t i v e

SiemensVDO Automotive AG „P.O. Box 10 09 43 „D-93009 Regensburg

Name
Department
Tel.
Fax
E-Mail
Internet
Our Ref.
Date.

Dagmar Kolar
SV C TS RBG EMC-Laboratory
+49(0)941/790-6699
+49(0)941/790-136699
dagmar.kolar@siemens.com
www.siemensvdo.de
Doc_5WK49096.doc
03/08/2005

Declaration of Conformity in accordance with Directive 1999/5/EC (R&TTE Directive)

Manufacturer: Siemens VDO Automotive AG
Body & Chassis Electronics

Address: Dep. SV C BC P2 RF TG
Siemenstrasse 12
D-93049 Regensburg
Germany

Product type designation: 5WK4 9096

Intended use: Radio frequency receiver used in vehicle locking/unlocking systems

The product mentioned above complies with the essential requirements and other relevant provisions of Directive 1999/5/EC, when used for its intended purpose:

Health and safety pursuant to §3.1.a: *Applied standard(s):*
EN 60950:2000

Electromagnetic compatibility pursuant to § 3.1.b: *Applied standard(s):*
EN 301 489-1,-3: V1.4.1 (2002-08)

Efficient use of spectrum pursuant to § 3.2: *Applied standard(s):*
EN 300 220-1: V1.3.1 (2000-09)

The following marking applies to the above mentioned product:



Siemens VDO Automotive AG

Regensburg, 2005-08-03

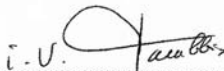
.....
Jean-Francois Tarabbia
Executive Vice President
Body and Chassis Electronics Operations

.....
Dr. Martin Fischer
Vice President
Wireless Products and Modules

SiemensVDO Automotive AG

Body & Chassis Electronics

Postal Address:
SiemensVDO Automotive AG

Office Address:
Siemenstrasse 12
D-93055 Regensburg
Tel. +49(0)941/790-0

Helmut Matschi
Klaus Müller

P.O. Box 10 09 43
D-93009 Regensburg

SiemensVDO Automotive AG „Chairman of the Supervisory Board: Edward G. Krubasik „Managing Board: Franz Wessnig, Chairman „Members: Klaus Egger, Günter Hauptmann, Johann Lötner „Registered Office: München „Commercial Registry: München, HRB 132837

Type approval

Declaration of Conformity appropriate to the Directive 1999/5/EC (R&TTE) Annex IV

Visteon Deutschland GmbH

.....
Manufacturer,

Notified Body consulted: **Cetecom ICT Services GmbH, Untertürkheimer Strasse 6-10,
D-66117 Saarbrücken**

ID-Number of Notified Body: **0682**

declare under our responsibility that the product: **Immobiliser System Transceiver**

Type: **PATS XCVR Start Control Unit**

Telecommunications Terminal Equipment Radio Equipment

Immobiliser System Transceiver

1

.....
Intended Purpose

.....
Equipment Class

complies with the appropriate essential requirements of the Article 3 of the R&TTE and the other relevant provisions, when used for its intended purpose.

Health and Safety requirements contained in Article 3 (1) a)

EN 60 950: 2001 Information technology equipment – Safety --

EN 50 371: 2002, Generic standard to demonstrate the compliance of low power electronic and electrical apparatus with the basic restrictions related to human exposure to electromagnetic fields (10 MHz – 300 GHz) – General public.

Protection requirements with respect to electromagnetic compatibility Article 3 (1) b)

EN 301 489-03 V.1.4.1: 08/2002, Electromagnetic Compatibility and radio spectrum Matters (ERM); Electromagnetic Compatibility (EMC) standard for radio equipment and services, Part 3: Specific conditions for Short Range Devices (SRD) operating on frequencies between 9 kHz and 40 GHz.

Means of the efficient use of the radio frequency spectrum

Air interface specification of the radio path contained in Article 3(2)

EN 300 330-1 V1.3.2: 12/2002 and **EN 300 330-2 V1.1.1:** 06/2001, Electromagnetic compatibility and Radio spectrum Matters (ERM); Short range devices (SRD); Radio equipment in the frequency range 9 kHz to 25 MHz and inductive loop systems in the frequency range 9 kHz to 30 MHz; Part 1: Technical characteristics and test methods and Part 2: Harmonized EN under article 3.2 of the R&TTE Directive.

Address:

Visteon Deutschland GmbH
Visteonstrasse 4 - 10
50170 Kerpen
Germany
URL: <http://www.visteon.com/europe>



Roland Greff
Vice President Visteon Deutschland GmbH

CE 0682

Audio introduction

RADIO RECEPTION

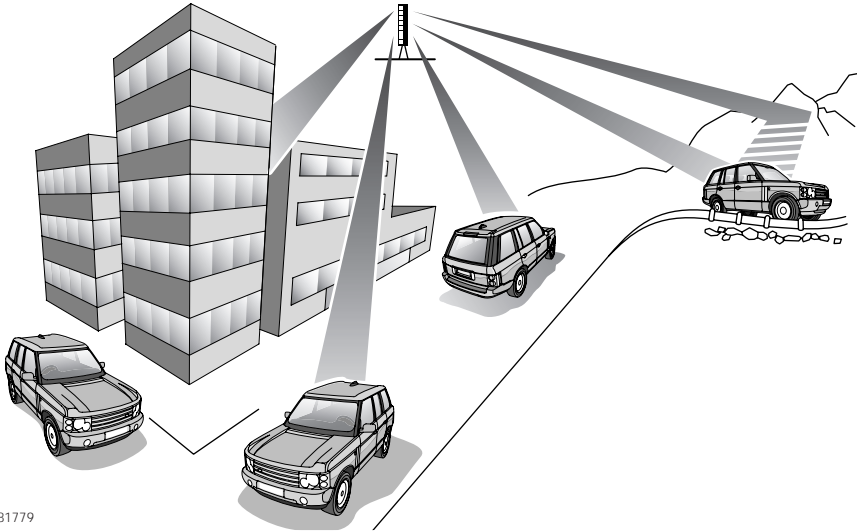

E81779

Some interference is to be expected from time to time during a journey. Occasionally it may be necessary to retune the audio unit to offset the effects of moving from one transmitter area to another.

While Radio Data System (RDS) automatic retuning helps to reduce the effects of signal changes, some manual retuning may still be required (especially for local stations) in areas of weak reception.

FM Signals travel in a straight line so large obstacles, such as tall buildings, can shield the vehicle from the signal, causing distortion or loss of reception (known as dead spots).

Distortion can also occur if FM signals received directly from the transmitter, mix with signals deflected by obstructions such as mountains, hills and tall buildings. This is known as multi-path distortion.

Note: *Although distortion, interference and lack of signal clarity are sometimes attributed to a fault in the radio, this is rarely the case.*

Audio unit overview

AUDIO UNIT OVERVIEW

Premium audio overview

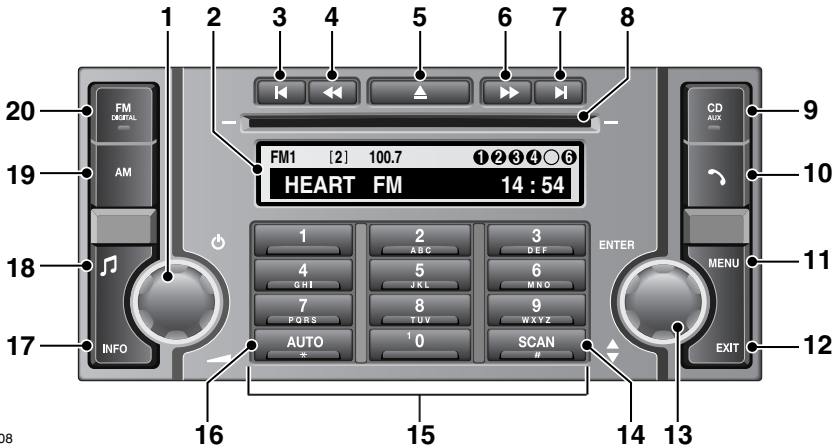

EB3108

1. On or off and volume control
 - Press to switch on or off
 - Rotate to adjust volume
2. Information display screen
3. Rearward search or previous track button
 - Radio station automatic rearward search
 - Compact disc previous track or beginning of track
4. Manual tuning or review button
 - Radio station manual rearward search
 - Compact disc rearward search (review)
5. Compact disc eject button
6. Manual tuning or cue button
 - Radio station manual forward search
 - Compact disc forward search (cue)
7. Forward search or next track button
 - Radio station automatic forward search
 - Compact disc next track
8. Compact disc slot
9. Compact disc player or AUX mode button
10. Telephone mode button
11. Audio MENU button:
 - FM settings
 - Clock
 - CD settings
 - Random
 - AUX settings
12. EXIT button
13. Audio MENU control
 - Rotate to scroll through options
 - Press to enable or disable the function
14. SCAN button
 - Press during CD play to listen to the first 10 seconds of each track
15. Input keypad
16. AUTO button
 - Press to automatically store radio stations

Audio unit overview

17. INFO button

- Press and release for traffic announcements
- Press and hold for news announcements

18. Tone and volume settings button

- Press and release for tone settings menu
- Press and hold for volume settings menu

19. AM waveband button

20. FM waveband button

Audio unit overview

Standard audio overview

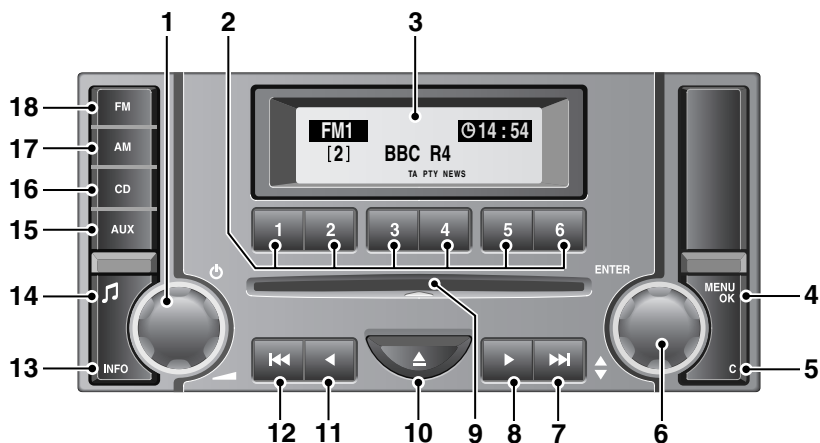

E83107

- 1.** On or off and volume control
 - Press to switch on or off
 - Rotate to adjust volume
- 2.** Radio station presets or CD disc selection
- 3.** Information display screen
- 4.** Audio MENU button:
 - Access
 - Save
 - Close
- 5.** Exit or Cancel button
- 6.** Audio menu control
 - Rotate to scroll through options
 - Press to enable or disable the function
- 7.** Forward search or next track button
 - Radio station automatic forward search
 - Compact disc forward search
- 8.** Manual tuning or cue button
 - Radio station manual forward search
 - Compact disc forward search (cue)
- 9.** Compact disc slot
- 10.** Compact disc eject button
- 11.** Manual tuning or review button
 - Radio station manual rearward search
 - Compact disc rearward search (review)
- 12.** Rearward search or previous track button
 - Radio station automatic rearward search
 - Compact disc previous track or beginning of track
- 13.** INFO button
 - Press and release for traffic announcements
 - Press and hold for news announcements
- 14.** Tone and volume settings button
 - Press and release for tone settings menu
 - Press and hold for volume settings menu
- 15.** Auxiliary input mode button
- 16.** Compact disc player mode button
- 17.** AM waveband button
- 18.** FM waveband button

Audio unit overview

Basic audio functions

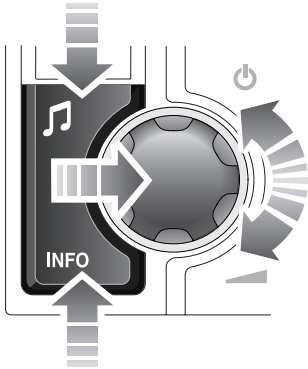

E83955

- Press rotary control to switch audio unit on or off.
- Rotate control to adjust volume or to adjust menu settings levels.
- Press and release tone button to access the tone settings menu.
- Press and hold tone button to access the volume settings menu.
- Press and release **INFO** button to activate or deactivate the traffic announcements (TA) function.
- Press and hold **INFO** button to activate or deactivate the news broadcasts function.

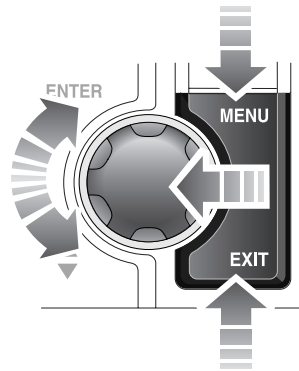

E83956

- Press **MENU** button to access various audio menus.
- Rotate control to scroll through menu items.
- Press rotary control to enter or confirm menu selection.
- Press and release **EXIT** button (**C** button on standard audio units) to go back to the previous screen.
- Press and hold **EXIT** button (**C** button on standard audio units) to return to main display.

Audio unit operation

ON OR OFF CONTROL

Press the on or off control to switch the audio unit on. Press again to switch off.

VOLUME CONTROL

Rotate the volume control to increase or decrease the audio unit volume. The volume can be set between **0** and **35**.

When the audio unit is turned on, the previously set volume level will be implemented.

Note: *The standard audio unit can be used with the engine off, but the maximum volume level will be restricted.*

Automatic Volume Control (AVC)

The AVC feature adjusts the volume level to compensate for the changes in road noise as the vehicle speed increases or decreases.

Note: *The AVC setting represents the volume increase and not the volume level.*

If the AVC level is set to **Off**, there will be no volume increase. With a low level setting, the volume increase at speed will be minimal. If a high level setting is used, there will be a noticeable increase of volume at speed.

The AVC setting required will depend upon the expected speed and the expected road conditions.

Use the following procedure to set the AVC level.

1. Press and hold the tone button to access the volume settings menu.
2. Press the tone button repeatedly until **AVC Level** is displayed.
3. Rotate the volume control to select the required AVC setting.

Reset volume settings

The following procedure will reset all of the volume settings to the original factory values.

1. Press and hold the tone button to access the volume settings menu.
2. Repeatedly press the tone button to scroll through the menu until the **Reset volume settings** message is displayed.
3. Rotate the volume control to highlight **YES** or **NO** as required.
4. On premium audio units, press the tone button to confirm your choice and exit the menu. On standard audio units, your choice is confirmed by pressing the **MENU** button.

AUDIO CONTROL

Depending on the specification of the audio system fitted to your vehicle, the following audio control settings are available from the tone menu.

Surround sound settings

1. Press and release the tone button to display the current surround sound setting.
2. Rotate the volume control to highlight **3 Channel** or **Stereo** as required.

Bass response adjustment

1. Press the tone button repeatedly until the current **Bass** setting is displayed.
2. Rotate the volume control to increase or decrease the level.

Treble response adjustment

1. Press the tone button repeatedly until the current **Treble** setting is displayed.
2. Rotate the volume control to increase or decrease the level.

Audio unit operation

Balance adjustment

1. Press the tone button repeatedly until the current **Balance** setting is displayed.
2. Rotate the volume control to adjust sound level to the right or left.

Fader adjustment

1. Press the tone button repeatedly until the current **Fader** setting is displayed.
2. Rotate the volume control to adjust the sound level to the front or rear.

Subwoofer settings

1. Press the tone button repeatedly until the current **Subwoofer** setting is displayed.
2. Rotate the volume control to increase or decrease the setting.

Centre speaker settings

1. Press the tone button repeatedly until the current **Centre** setting is displayed.
2. Rotate the volume control to increase or decrease the setting.

Resetting tone values

Use the following procedure to return the tone settings to the factory defaults.

1. Press the tone button repeatedly until the **Reset tone settings** message is displayed.
2. Rotate the volume control to highlight **YES** or **NO** as required.
3. On premium audio units, press the tone button to confirm your choice. On standard audio units, use the **MENU** button.

All settings will be reset to the neutral (central) value.

WAVEBAND BUTTON

To select the FM waveband, press and release the **FM** button. Repeated presses will scroll between **FM1** and **FM2**. On standard audio units **FMA** is also available. The selection will be shown in the top left-hand corner of the information display.

To select the AM waveband, press and release the **AM** button. The selection will be shown in the top left-hand corner of the information display. On standard audio units, repeated presses of the **AM** button will scroll through **MW1**, **MWa**, **LW1** and **LWa**.

Audio unit operation

AUTOSTORE CONTROL

Autostoring radio stations - Premium audio

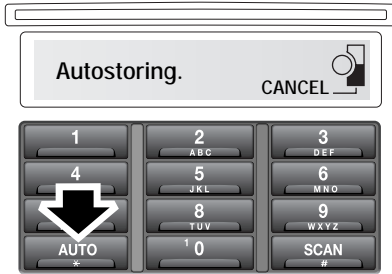

E82933

To autostore stations on premium audio units, select the required waveband, then press and hold the **AUTO** button for three seconds.

Autostoring will be shown in the information display and the stations will be stored under the preset numbers in the order in which they are found.

To access the autostored stations, press and release the **AUTO** button. **FMA** or **AMA** will be displayed, depending on the selected waveband.

To recall an autostored station, press and release the required preset number.

To exit the selected autostore waveband, press and release the **AUTO** button.

Autostoring radio stations - Standard audio

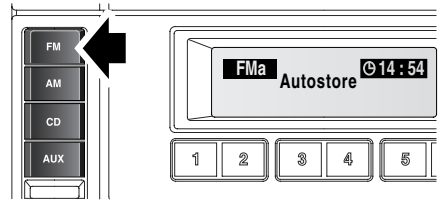

E83959

To autostore stations on standard audio units, select the required waveband, then press and hold the relevant waveband button for three seconds. **Autostore** will be shown in the information display and the stations will be stored under the preset numbers in the order in which they are found.

To recall an autostored station, press and release the required preset number.

Audio unit operation

STATION PRESET BUTTONS

Premium audio

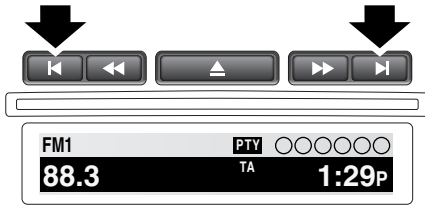

E82929

Standard audio

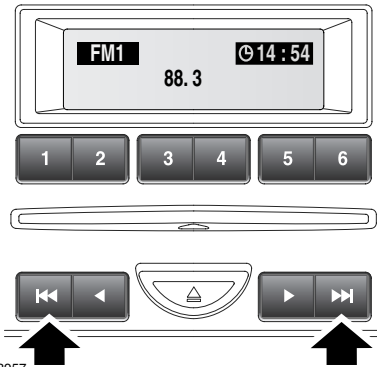

E83957

To store a station, press either of the search buttons to find the next available station. Having tuned to the desired station, press and hold the preset number under which you would like the station stored.

The audio output will be muted when the button is pressed, and dependent on specification, accompanied by the message **Station stored**.

Premium audio

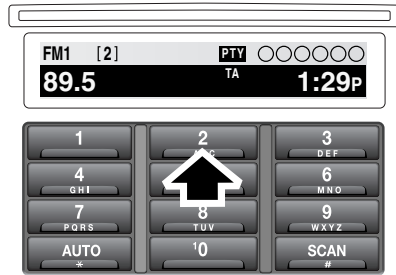

E82930

Standard audio

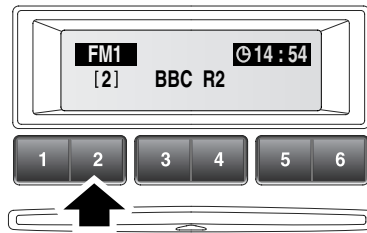

E83958

To access the stored stations, press and release the required preset number.

TRAFFIC INFORMATION CONTROL

The Traffic Announcement (TA) feature detects the presence of local travel announcements, providing information on local conditions. As soon as a traffic announcement is received, radio reception or CD play is interrupted. At the end of the traffic announcement, radio or CD play will resume.

Press and release the **INFO** button to switch **TA** on or off.

To cancel an announcement, briefly press the **EXIT** or **C** button.

Audio unit operation

Traffic Programme (TP) preference

With the Traffic Announcement (TA) feature enabled, any announcement received by the system will interrupt normal radio reception or CD play. The TP preference feature on premium audio units allows the system to receive only traffic announcements from a particular station.

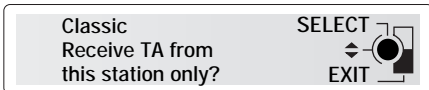
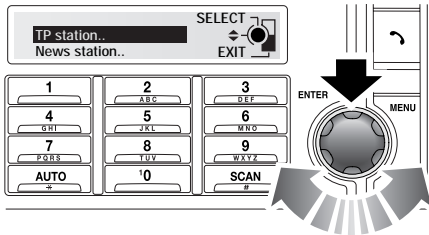
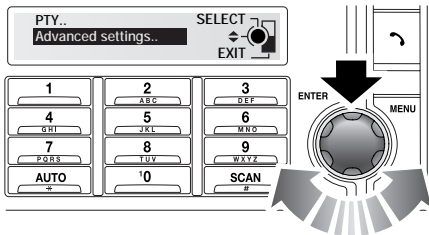
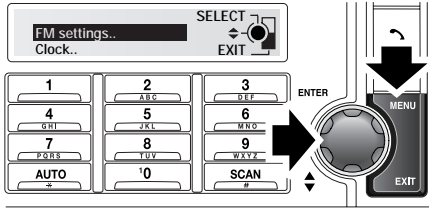

E83273

2. Use the rotary control to select **FM Settings** and press to confirm.
3. Use the rotary control to highlight **Advanced settings** and press to select.
*Note: The **Advanced settings** menu is not available while the vehicle is moving.*
4. Rotate the control until **TP station** is selected and press to confirm selection.
5. When the station name or frequency is displayed along with the message **Receive TA from this station only?**, press the rotary control to confirm.

1. With the preferred station selected, press the **MENU** button.

Audio unit menus

RADIO DATA SYSTEM (RDS)

Your audio system is equipped with RDS (Radio Data System), which enables the audio unit to receive extra information with the normal radio signals.

On the FM waveband, RDS enables the audio to receive traffic and news information broadcasts. RDS also allows the audio unit to automatically retune to stations that are linked to the same network.

Note: Not all FM radio stations broadcast RDS. If a non-RDS station is selected, RDS features will not be available.

Selecting RDS

On standard audio units, RDS can be enabled or disabled, according to preference. The following procedure explains how to switch RDS on or off.

1. With **FM1**, **FM2** or **FMA** selected, press the **MENU** button to display the menu.
2. Using the rotary control, select **RDS** from the menu. **ON** or **OFF** will be displayed, dependent on status.
3. Press the rotary control to change status.

The RDS status will be displayed briefly on the information screen.

REGIONAL MODE (REG)

As you drive into different radio reception areas, the Radio Data System (RDS) automatically retunes the radio to the strongest signal. Regional mode is an RDS feature which stops the system from tuning to another local radio station with a stronger signal. With this feature enabled, your selected local radio station will remain tuned.

Regional mode - Premium audio

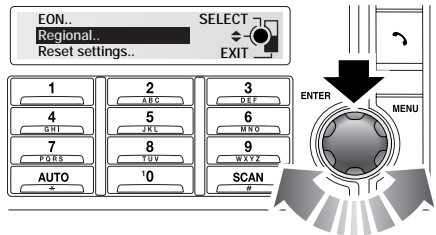
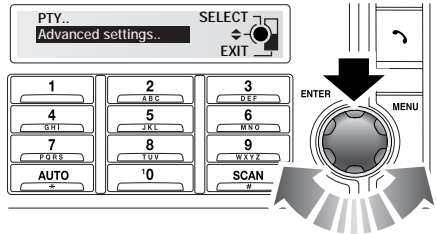
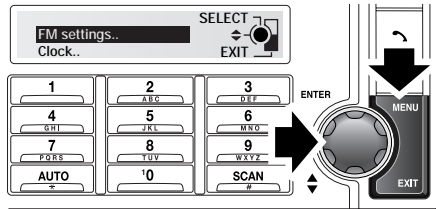

E83261

1. With **FM1**, **FM2** or **FMA** selected, press the **MENU** button.
2. Use the rotary control to select **FM Settings** and press to confirm selection.
3. Use the rotary control to select **Advanced settings** from the menu and press to confirm selection.

Audio unit menus

Note: The **Advanced settings** menu is not available while the vehicle is moving.

4. From the next menu select **Regional** and press to confirm selection.
5. To enable Regional mode, rotate the control until **On** is selected and press to confirm selection.

Regional mode - Standard audio

1. With **FM1**, **FM2** or **FMA** selected, press the **MENU** button to display the menu.
2. Using the rotary control, select **Regional** from the menu. **ON** or **OFF** will be displayed, dependent on status.
3. Press the rotary control to change status. The regional status will be displayed briefly on the information screen.

ENHANCED OTHER NETWORK (RDS-EON)

The Enhanced Other Network (EON) feature will tune to any radio station of the same station network as the one that you are listening to, once the signal gets weak.

Either local or distant networks can be selected by the EON feature.

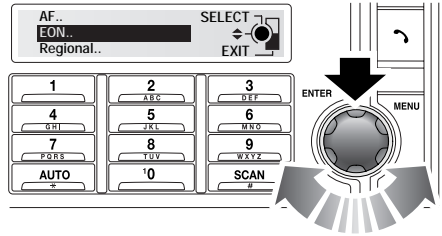

E83263

1. With **FM1**, **FM2** or **FMA** selected, press the **MENU** button.
2. Use the rotary control to select **FM Settings** and press to select.
3. Use the rotary control to select **Advanced settings** and press to confirm selection.

Note: The **Advanced settings** menu is not available while the vehicle is moving.

4. Use the rotary control to select **EON** and press to confirm selection.
5. To enable or disable the EON mode, rotate the control to select **Off**, **Local** or **Distant** and press to confirm selection.

ALTERNATIVE FREQUENCIES

As the Radio Data System (RDS) receives information about the frequencies being used by nearby transmitters, it can choose the strongest signal for the selected station. With the Alternative Frequencies (AF) feature enabled, you will not need to retune the radio as you drive between different transmitter areas.

Audio unit menus

Alternative Frequency (AF) - Premium audio

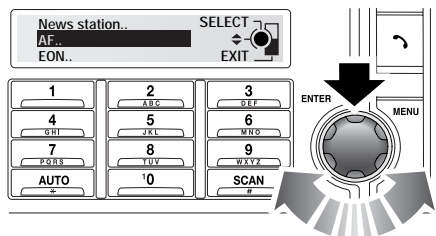

E83262

1. With **FM1**, **FM2** or **FMA** selected, press the **MENU** button.
2. Use the rotary control to select **FM Settings** and press to select.
3. Use the rotary control to select **Advanced settings** and press to confirm selection.

Note: The **Advanced settings** menu is not available while the vehicle is moving.

4. Use the rotary control to select **AF** and press to confirm selection.
5. To enable AF mode, rotate the control until **On** is highlighted and press to confirm selection.

Alternative Frequency (AF) - Standard audio

1. With **FM1**, **FM2** or **FMA** selected, press the **MENU** button to display the menu.
2. Using the rotary control, select **AF Switch** from the menu. **ON** or **OFF** will be displayed, dependent on status.
3. Press the rotary control to change status.

The AF switch status will be displayed briefly on the information screen.

NEWS BROADCASTS

The news broadcasts feature detects the presence of local news. As soon as a news broadcast is received, radio reception or CD play is interrupted. At the end of the news broadcast, radio or CD play will resume.

Press and hold the **INFO** button to switch news announcements on or off.

Note: Both traffic and news information can be selected at the same time. However, the audio unit will always give priority to traffic information.

To cancel an announcement, press and release the **EXIT** or **C** button.

Note: Cancelling an announcement in this way will not prevent further announcements when they become available.

News station preference

With the news feature enabled, any announcement received by the system will interrupt normal radio reception or CD play. The news station preference feature allows the premium audio system to only receive news announcements from a particular station.

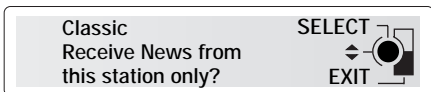
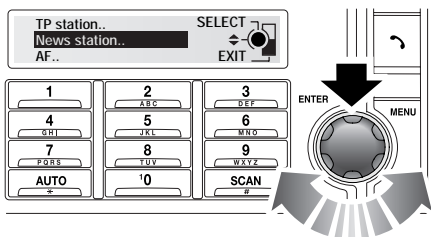

E83266

1. With the preferred news station selected, press the **MENU** button.

Audio unit menus

- Use the rotary control to select **FM Settings** and press to confirm.
- Use the rotary control to highlight **Advanced settings** and press to select.

*Note: The **Advanced settings** menu is not available while the vehicle is moving.*

- Rotate the control until **News station** is selected and press to confirm selection.
- When the station name or frequency is displayed along with the message **Receive news from this station only?**, press the rotary control to confirm.

PRIORITY PROGRAMME TYPE (PTY)

The RDS (Radio Data System) allows programmes to be categorised by the broadcast type (rock music, current affairs, news, etc).

This in turn allows you to search for a station by choosing the type of broadcast that you wish to listen to.

PTY selection - Premium audio

The type of programme searched for by the PTY feature can be selected from the PTY selection list.

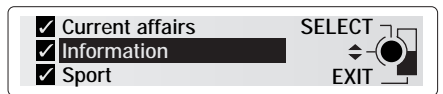
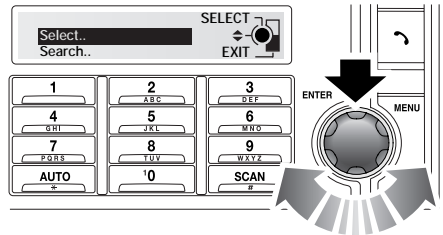
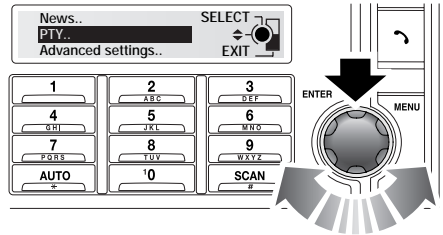
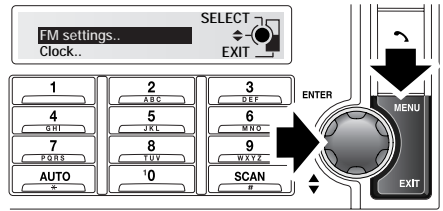

E83736

- Press the **Menu** button to enter the menu.
- Press the rotary control to select **FM settings**.
- Use the rotary control to scroll through the menu until **PTY** is highlighted, then press the rotary control.
- Use the rotary control to scroll through the menu until **Select** is highlighted, then press the rotary control.

Audio unit menus

5. Having entered the **PTY** select menu, use the rotary control to scroll through the programme types until your choice is highlighted.
6. Press the rotary control to select or deselect the programme type(s) required.
7. Press the **EXIT** button to return to the **PTY** menu.

PTY programme types

1. News
2. Current affairs
3. Information
4. Sport
5. Education
6. Drama
7. Culture
8. Science
9. Varied speech
10. Pop music
11. Rock music
12. Easy listening
13. Light classic
14. Serious classic
15. Other music
16. Weather
17. Finance
18. Childrens
19. Social affairs
20. Religion
21. Phone in
22. Travel and touring
23. Leisure and hobby
24. Jazz music
25. Country music
26. National music

27. Oldies music
28. Folk music
29. Documentary

PTY search - Premium audio

1. Press the **Menu** button to enter the menu.
2. Press the rotary control to select **FM settings**.
3. Use the rotary control to scroll through the menu until **PTY** is highlighted, then press the rotary control.

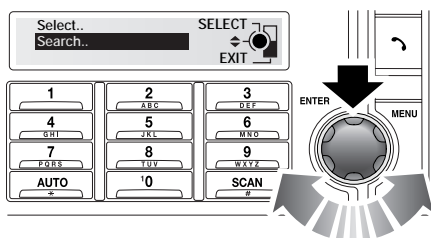

E83106

4. Use the rotary control to scroll through the menu until **Search** is highlighted, then press the rotary control. The audio system will then search for all pre-selected programme types.
5. To abort a **PTY** search, press the **EXIT** button.

Once the search is complete, **PTY** will be displayed on the screen with the station information. To skip to the next or previously stored **PTY** station, press the forward or rearward search arrow button.

Audio unit menu

PTY seek - Standard audio

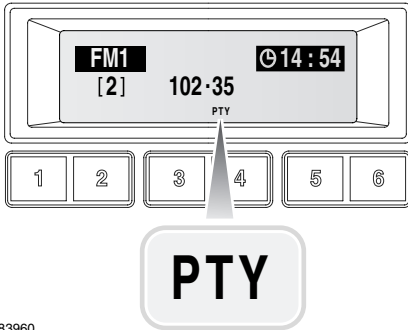
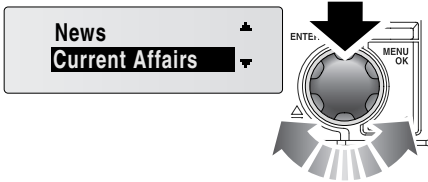
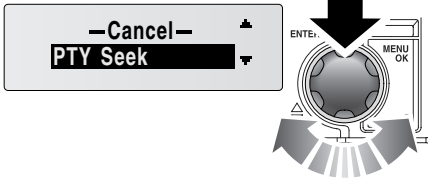

E83960

1. Press the **Menu** button to enter the menu.
2. Use the rotary control to scroll through the menu until **PTY Seek** is highlighted, then press the rotary control.
3. Use the rotary control to scroll through the programme types until your choice is highlighted.
4. Press the rotary control to start searching for the selected programme type.

Once a matching station is found, it will continue to play. If you wish to continue searching, press the search up or down buttons within 30 seconds.

To abort PTY seek, press the **C** button.

RESETTING THE AUDIO UNIT

It is possible to reset the RDS settings on the premium audio unit to the default values in one operation.

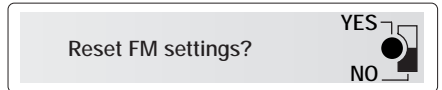
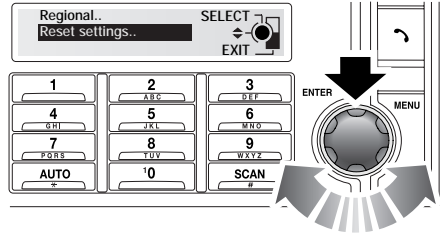

E83537

1. With the preferred news station selected, press the **MENU** button.
2. Use the rotary control to select **FM Settings** and press to confirm.
3. Use the rotary control to highlight **Advanced settings** and press to select.

Note: The **Advanced settings** menu is not available while the vehicle is moving.

4. Rotate the control until **Reset settings** is selected and press to confirm selection.
5. When the message **Reset FM settings?** appears, press the rotary control to confirm, or the **EXIT** button to cancel.

Digital audio broadcasting

GENERAL INFORMATION

Digital radio reception

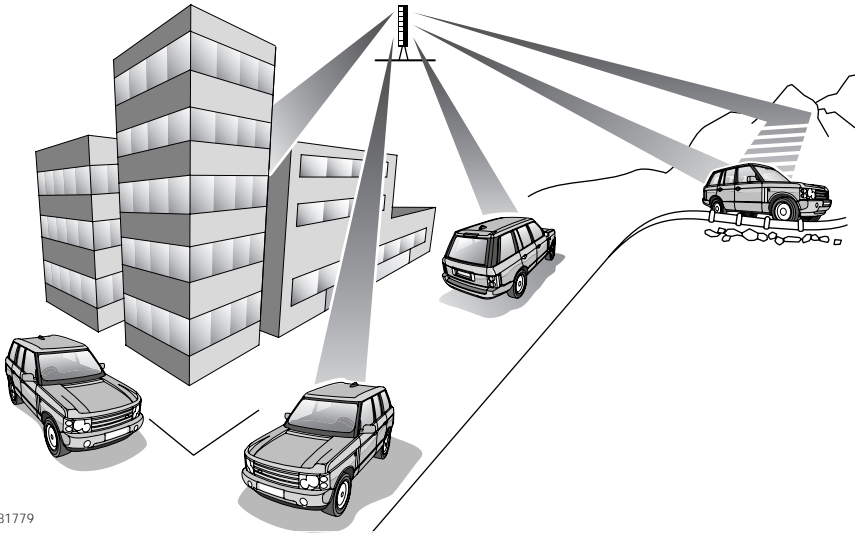

E81779

Digital audio broadcasting (DAB) provides a clear signal with minimal interference, hiss or fading. After a channel (or station) has been tuned and stored, you do not need to retune.

Radio signals travel in a straight line so large obstacles, such as tall buildings, can shield the vehicle from the signal, causing temporary loss of reception (known as dead spots).

Digital radio is transmitted from regional terrestrial transmitters. Some local digital radio channels are not available outside the range of a transmitter. If you want to listen to new local channels as you move around the country, you will need to use the auto-tune function (AUTO) to build new channel lists.

Digital radio channels are organised into groups called ensembles (also known as multiplexes). Some individual channels may also provide a number of subchannels. For example, if several sports events are being held simultaneously, the channel may temporarily choose to broadcast each different event on a separate subchannel.

Digital audio broadcasting

AUDIO CONTROLS

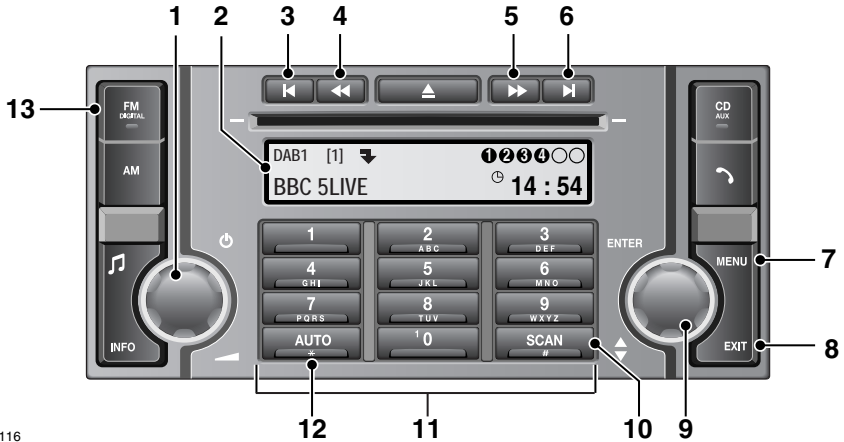

E88116

1. On/off and volume control
2. Information display screen
3. Ensemble search down
 - Press and release to find previous digital ensemble
 - Press and hold to display a list of all available ensembles
4. Channel search down
 - Press and release to find previous digital channel
 - Press and hold to access subchannels (if available), then press and release to find previous subchannel
5. Channel search up
 - Press and release to find the next digital channel
 - Press and hold to access subchannels (if available), then press and release to find next subchannel
6. Ensemble search up
 - Press and hold to find the next digital ensemble
7. MENU button
8. EXIT button
 - Press and hold to save changes and exit the menu
 - Press and release to move up to the previous menu
9. Menu control
 - Rotate to scroll through a menu and highlight menu options
 - Press to select menu options
10. SCAN button
 - Press to listen to an eight-second broadcast of each channel in sequence, press again to select a channel
11. Keypad buttons. Preset store and recall
12. AUTO button
 - Press and hold to start automatic tuning of available ensembles and channels

Digital audio broadcasting

13. FM/DIGITAL button

- Press and release to select the next available radio source FM1, FM2, DAB1, DAB2

DISPLAY OPTIONS

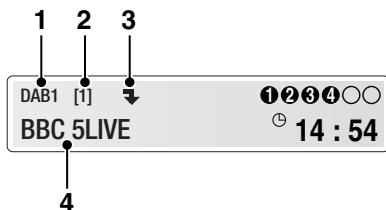

E88132

1. Digital source indicator
2. Preset number for current channel
3. Subchannel indicator (or **SubCh** if a subchannel is being received)
4. Channel name

Note: The display can also show ensemble or programme type (PTY) information if you have selected one of these options via the menu. See **SETTINGS** (page 240).

CHANNEL AUTOMATIC TUNING

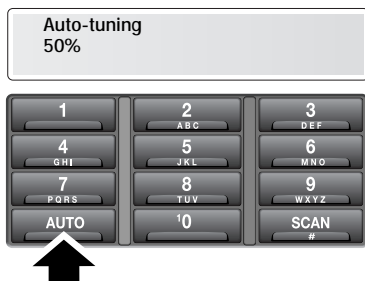

E88130

Note: When you first use your DAB radio, you will be unable to listen to any digital stations until you have used the auto-tune function.

Press and hold the **AUTO** button to start automatic tuning and build a list of all the digital ensembles and channels available in the region you are located.

While automatic tuning is running, the message **Auto-tuning** will be displayed along with a percentage complete. When tuning is complete, the first channel found will start playing.

To update the list of local channels when you move to a different region, press and hold the **AUTO** button again.

CHANNEL OPTIONS

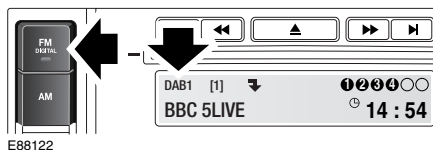

E88122

To receive digital broadcasts, press and release the **FM/DIGITAL** button repeatedly to toggle between the **FM1**, **FM2**, **DAB1** and **DAB2** sources. Choose either **DAB1** or **DAB2** to receive digital broadcasts. The channel that was last played on your chosen digital source will be selected for playback automatically.

Note: If this is the first time you have used **DAB**, before you can select a channel, you need to build a list of available channels using the auto-tune function. See **CHANNEL AUTOMATIC TUNING** (page 236).

Digital radio channels are organised into groups called ensembles and some individual channels may provide a number of subchannels. You can search for channels, subchannels or ensembles to find the digital broadcast you require.

Digital audio broadcasting

Selecting a channel

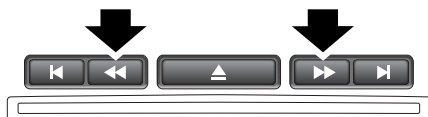

E85661

Press and release one of the channel search buttons to select the next available digital channel. The up (>>) button selects the next channel, the down (<<) button selects the previous channel.

Note: If the next or previous channel is in a different ensemble, then there will be a short pause before the channel is located. The message **Please wait...** is displayed on the screen.

Selecting a subchannel



E88124

If subchannels are available under the channel you have selected, the subchannel arrow icon is displayed.

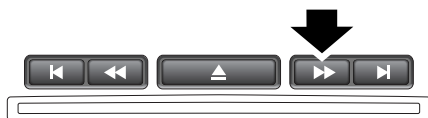

E88125

Press and hold either of the channel search buttons to access a list of subchannels. Then, to find the next subchannel, press and release the channel search button.

If more than one subchannel is available, press and release the channel search button repeatedly to scroll through the list. To return to the main channel, press and hold one of the channel search buttons. You can also search subchannels from the settings menu. See **SETTINGS** (page 240).

Note: when you select and play a subchannel, the arrow icon is replaced by **SubCh** on the display screen.

Selecting an ensemble



E85662

Press and release the ensemble search buttons to find the next available ensemble. The up (>|) button finds the next ensemble, the down (|<) button finds the previous ensemble. After a few seconds wait the first channel in the ensemble you have selected will play.

Digital audio broadcasting

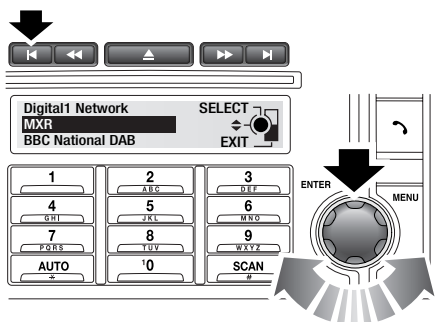

E88123

Press and hold an ensemble search button to display a list of all available ensembles. Rotate the menu control to scroll through the ensemble list and press it to select one and display a list of channels in that ensemble.

Scanning channels



E88126

You can use the scan function to listen to a short broadcast of each available channel in turn before selecting the one you prefer.

Press and release the **SCAN** button to start the channel scan and play the first channel. After eight seconds, the scan moves to the next channel and so on. After the last channel in an ensemble, the first channel in the next ensemble is played. To stop the scan and play the current channel, press the SCAN button again or press the Exit button.

Note: Subchannels are not included in scanning.

Signal availability



E88127

If the digital radio signal is lost or the system takes time to tune in to a channel, then the display screen will show the message **No reception**.

The problem may be caused by a temporary problem, such as buildings or trees blocking the signal, or it might be a problem with the broadcast service operator. Try tuning to an alternative channel and return later to see if the problem has been resolved. If you are unable to tune to any other channels, switch off the audio unit and then try again.

PRESET BUTTONS

Storing channels as presets

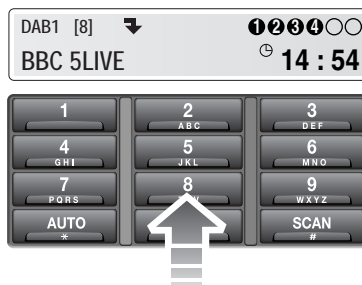

E88128

You can store up to twenty digital channels (ten each on **DAB1** and **DAB2**) using the numbered preset buttons.

1. Search for and start playing the channel you want to preset.

Digital audio broadcasting

- Press and hold the preset button (for about two seconds) on which you want to store the current channel. Audio output is muted for a further two seconds while the channel is stored and a confirmation message is displayed.
- Repeat steps 1 and 2 for each channel that you want to store as a preset.

Note: You cannot store a subchannel as a preset. If you try to store a subchannel, you will store the channel to which the subchannel belongs.

Recalling a preset channel



E88129

Make sure that you have selected the appropriate digital source (**DAB1** or **DAB2**) and then press and release the preset button you require. The channel you have selected will start to play automatically.

Note: If you try to recall a channel that has previously been stored as a preset but is now unavailable or invalid, the message **No channel found** is displayed. You must choose another channel.

Scrolling through presets

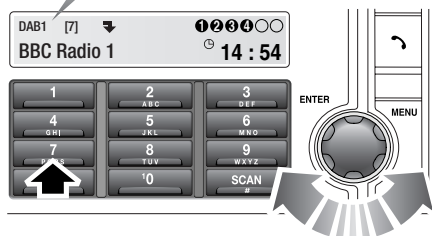
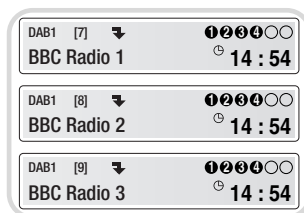

E88131

Rotate the menu control to scroll through all available presets for the current digital source (**DAB1** or **DAB2**). When you stop rotating, the selected channel will start to play automatically after a few seconds.

Note: If you are listening to a subchannel, then rotating the menu control will return you to, and then scroll through, the channel preset list.

Digital audio broadcasting

SETTINGS

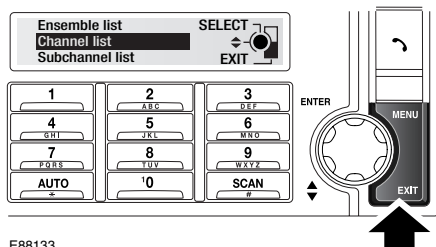
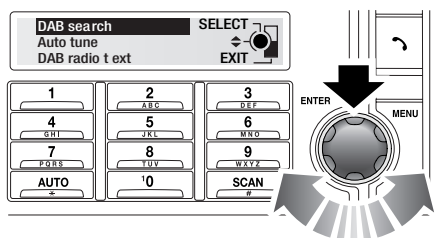
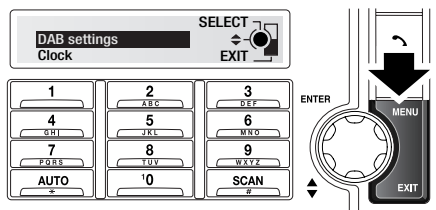

E88133

A number of different functions are available from the DAB settings menu. Follow the procedure below to access the menu.

1. While you are using either the DAB1 or DAB2 source, press and release the **MENU** button.
2. Press and release the menu control to select **DAB settings**.
3. Rotate the menu control to scroll through, and highlight, the menu options displayed.
4. Press and hold the **EXIT** button to save any changes you have made and return to normal audio mode.

Note: To navigate up to a previous menu level, press and release the **EXIT** button.

Note: If you have pressed the **MENU** button once but take no action for ten seconds, the system will exit the menu automatically.

DAB search

To find a specific broadcast, use the **DAB search** menu. You can scroll through, and choose from, complete lists of ensembles, channels, subchannels or programme type (PTY) categories.

Digital audio broadcasting

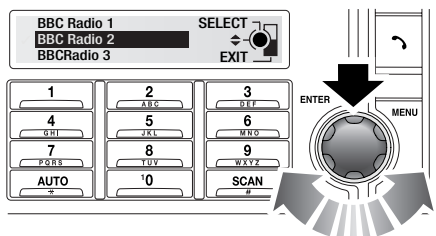
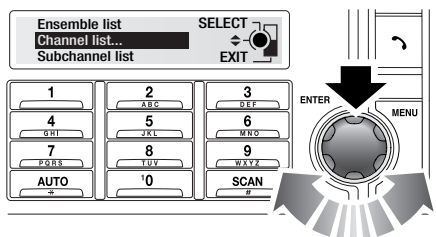
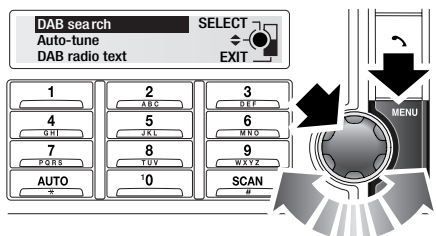

E88134

1. From the **DAB settings** menu, choose **DAB search**.
2. Press and release the menu control to view the following options: **Ensemble list** to view a list of all ensembles and the channels within each ensemble-; **Channel list** to view a list of all available channels. **Subchannel list** to view a list of all subchannels (if available) under the channel currently playing **PTY** to list all PTY categories (News, Sport, Talk etc.) and the channels within each category.

3. Rotate the menu control to scroll through the list, then press and release the menu control to choose from a list.

Auto-tune

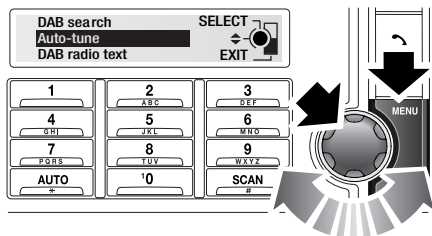

E88135

Auto-tune builds a list of all the available digital channels for the region you are in. See **CHANNEL AUTOMATIC TUNING** (page 236).

From the **DAB settings** menu, choose **Auto-tune** to start. The message **Auto-tuning...** is displayed along with a percentage to indicate progress.

Note: You can also press and hold the **AUTO** button to start auto-tuning.

DAB radio text

You can change the type of information that is displayed on the screen when a channel or subchannel is playing.

Digital audio broadcasting

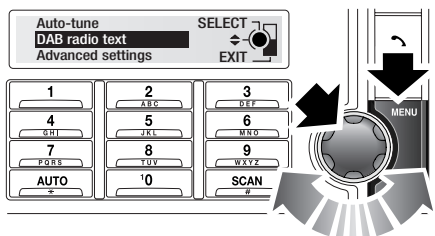

E88139

- **Off** to display only the channel name.

Advanced settings

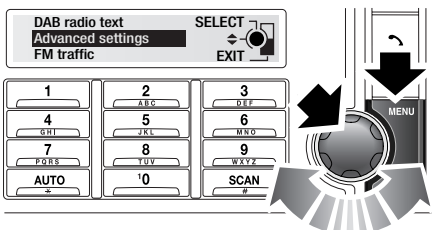
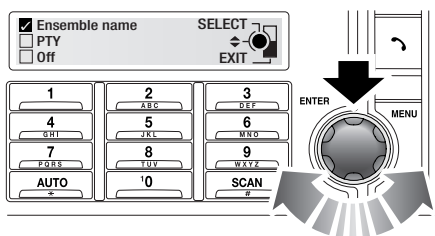

E88136

From the **DAB settings** menu, choose **DAB radio text**. Rotate the menu control and press to select one of the following:

E89492

From the **DAB settings** menu, choose **Advanced settings**. Use the menu control to navigate the menu options below.



Link DAB

Some DAB channels are broadcast in a number of different ensembles. For example, some national channels may broadcast a number of regional variations of the same channel under different ensembles.

E88137

- **Ensemble name** to display the name of the ensemble to which the current channel belongs.



E88138

- **PTY** to display the name of the ensemble to which the current channel belongs.

Digital audio broadcasting

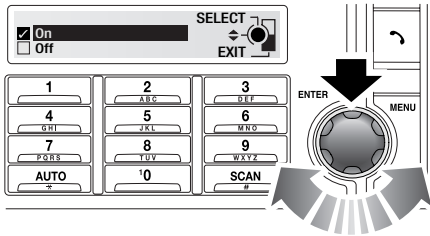
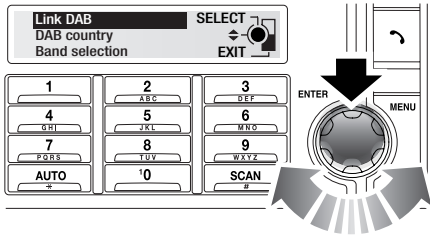

E88140

If the **Link DAB** setting is switched on and the signal strength for a channel falls below an acceptable level, the audio unit will automatically search other available ensembles for a channel with the same name.

If an alternative local channel is found, then the message **Switching ensemble** is displayed and the new channel is played automatically after a few seconds. If the channel is not found after a few seconds, the message **No signal** is displayed.

DAB country

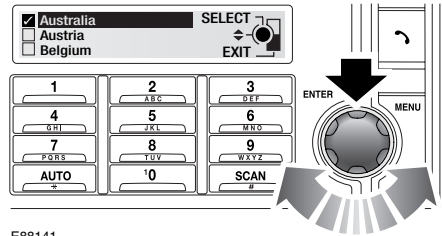
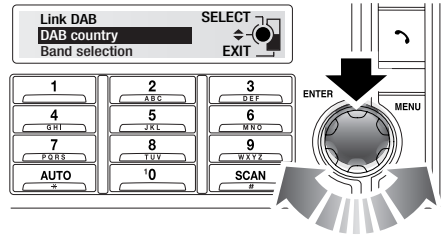

E88141

If you move the vehicle to a different country, you can change **DAB country** setting to make sure that the audio unit gives the best possible reception and sound quality. Rotate the menu control to highlight the new country in the list. Press and release the menu control to check the box next to the selected country.

Note: When you change the DAB country, the audio unit automatically starts auto-tuning. See **CHANNEL AUTOMATIC TUNING** (page 236).

Digital audio broadcasting

Band selection

Different regions or countries may use different digital bands to broadcast DAB channels. If you know the band(s) required then you can choose from the **Band selection** menu. The available bands are:

- LBand
- BandIII
- LBand & BandIII
- LBandCanada
- LBandCan & BandIII

Reset DAB settings

If you want to reset the DAB settings to the manufacturer's defaults, use the menu control to choose the **Reset DAB settings** menu option. Press the menu control again to confirm the reset.

FM traffic and news

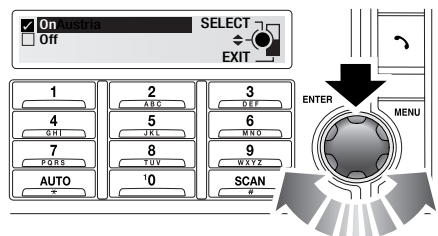
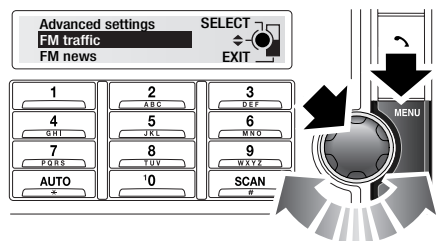

The FM traffic function detects the presence of local travel announcements, while the FM news function detects local news announcements. As soon as an announcement is received, radio reception or CD play is interrupted. At the end of the announcement, radio or CD play will resume. You can use this menu option to turn announcements on or off.

From the **DAB settings** menu, choose **FM traffic** or **FM news** and then press and release the menu control to select either **On** or **Off**. To cancel a traffic or news announcement and return to the digital channel, press and release the **EXIT** button. Cancelling an announcement temporarily will not prevent further announcements from broadcasting when they become available.

Note:

Both traffic and news information can be selected at the same time. However, the audio unit will always give priority to traffic information.

Note:

Traffic and news announcements are not currently available from DAB services, so the audio unit switches to an FM channel just for the duration of the announcement, so there may be some temporary loss of sound quality.

E88142

Compact disc player

LOADING COMPACT DISCS

CAUTION



Do not force the disc into the slot.

Note: Some music CD manufacturers are using data encryption to copy-protect their recordings and prevent the production of counterfeit copies. These CDs differ from the internationally agreed CD audio standard, RedBook, a standard that serves as the operating basis for all CD players and changers. Copy-protected CDs may fail to play in your CD changer or may be played subject to various limitations, e.g. sound quality may be impaired. If you do experience a problem, try the CD in other players before contacting the CD vendor.

CAUTION



Do not use discs with paper labels, Dual Discs or DVDPlus discs. The front loading CD player may load and play this type of disc, however, it is likely that the disc will not eject and will block the CD mechanism. Such damage to a CD player will not be covered under warranty.

Loading a CD - Single disc player

To insert a disc into the player, make sure that the label side of the disc is facing upwards and present the disc to the slot. Ease the disc into the slot until the mechanism takes over and draws the disc in fully.

Loading a CD - Six disc player

Press the **CD** mode button, then press the numbered button of the position in which the compact disc is to be stored (**1** to **6**).

Make sure that the label side of the disc is facing upwards then, when prompted, partially insert the disc. The player mechanism will draw the disc in automatically and the disc number will appear on the display.

Note: If there is a problem with a disc that has been loaded (inserted upside down, wrong format etc.), **Disc unreadable** or **Disc error** will appear in the information display, and the disc will be ejected. If the problem can be corrected (disc upside down for example), then re-insert the disc in the correct manner. If the problem cannot be rectified, do not re-insert the disc.

There will be a pause while the player reads information from the disc, then play will start at the first track.

To load another CD, press another numbered button (**1** to **6**) and repeat the loading procedure.

Note: The six circles in the top right-hand side of the information display of the premium unit, represent the six available CD positions. As soon as a CD is loaded, its number will appear in the circle.

Load all

This feature is only available on the standard audio, six disc CD player.

1. Press and hold the **CD** button until **Load All** appears on the display.
2. When prompted, partially insert the first disc. The player mechanism will draw the disc in automatically.
3. When prompted, continue to insert discs until all six discs have been loaded. When fully loaded, the CD player will commence playing CD1.

Compact disc player

EJECTING COMPACT DISCS

It is only possible to eject a single disc, if it is currently selected or playing.

To eject a disc, press and release the eject button. A confirmation message will be shown on the information display. After a short pause, the disc will be presented. The disc should then be removed.

Note: *If the disc is not removed from the slot within fifteen seconds, it will be drawn back into the player.*

EJECTING MULTIPLE COMPACT DISCS

All the discs loaded in the player can be ejected in sequence. To eject all of the discs, press and hold the eject button. A confirmation message will be shown on the information display. After a short pause, the first disc will be presented. The disc should then be removed.

The discs will be ejected one at a time with a short pause in between each.

To stop the process, press any CD number button (1 to 6).

COMPACT DISC SELECTION

To select one of the loaded discs, briefly press the disc number required (1 to 6). If the position selected does not contain a disc, there will be a pause and a message will appear on the information display.

Once a disc has been inserted, there will be a pause while the player reads the disc information. Playback will then begin at the start of track one.

COMPACT DISC PLAYBACK

To start compact disc playback, briefly press the **CD** mode button, followed by the disc number required. If no disc number is selected, playback will begin at one of two places:

- If the discs have not been removed since their last use, playback will begin from the point at which it was stopped previously.
- If the discs have not been used since they were inserted, playback will begin at the start of the first loaded disc.

TRACK SELECTION

Premium audio

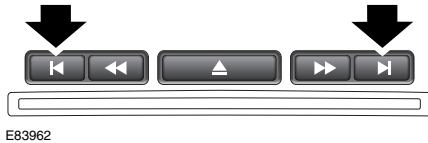

Standard audio

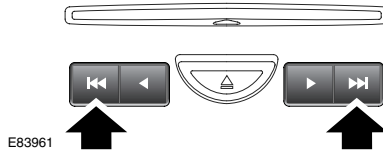

To return to the start of a track, or skip to the next track during playback, press and release the appropriate button.

COMPACT DISC PAUSE

To pause or stop compact disc playback, briefly press one of the other mode buttons, **AM** or **FM** for example. Press the **CD** button to continue playback.

On premium audio units, CD play will also pause when the volume is turned down to **0**. Play will resume when the volume is turned back up.

Compact disc player

FAST FORWARD/REVERSE

Premium audio

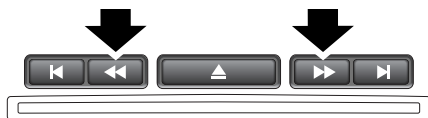

E83964

Standard audio

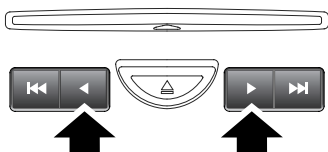

E83963

To search forwards or backwards through the current track, press and hold the relevant search button.

COMPACT DISC FUNCTION MENU

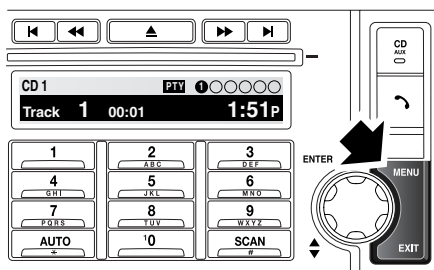

E82981

Depending on the specification of the audio unit, the following extra functions are available using the compact disc function menu:

- Random
- CD text
- CD scan
- Repeat
- TA
- News

Select compact disc mode, then briefly press the **MENU** button. Use the rotary control to select **CD settings**. Press the rotary control to confirm selection. Use the rotary control to select the required function and press to confirm selection. Rotate the control to enable or disable the function.

COMPACT DISC DISPLAY OPTIONS

Some compact discs, including MP3 files, have information which can be displayed on the premium audio display screen. Instead of the track number, it is possible to view the track title with the CD text function enabled.

To enable or disable the CD text function, select compact disc mode, then briefly press the **MENU** button. Use the rotary control to highlight **CD settings** and press to confirm selection. Using the rotary control, select **CD TEXT** from the menu. Rotate the control to select **On** or **Off** and press to confirm selection.

SHUFFLE/RANDOM

Random alters the playback sequence for the loaded discs. The tracks are selected randomly by the player.

Compact disc player

Random selection - Premium audio

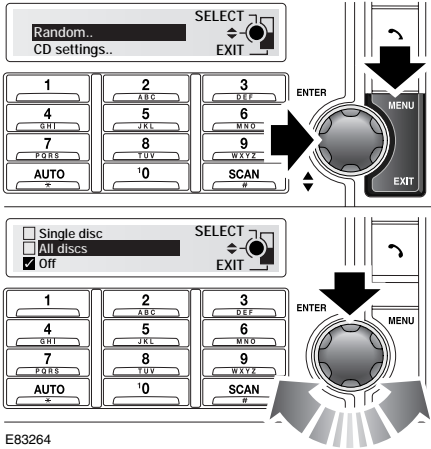

E83264

1. Press the **Menu** button to access the menu.
2. Use the rotary control to select **Random** and press to confirm selection.
3. From the following menu, use the rotary control to select **Off**, **All discs** or **Single disc**. Press the control to confirm selection. Press the **EXIT** button to return to the previous menu.

Note: When **All discs** is selected, the system will ignore MP3 discs and only play standard audio discs.

Random selection - Standard audio

1. Press the **Menu** button to access the menu.
2. Use the rotary control to select **Random**.
3. Press the rotary control to enable or disable the function as required.

REPEAT COMPACT DISC TRACKS

Repeat allows the current track to play repeatedly until it is stopped or cancelled.

Note: This feature is only available on standard audio units.

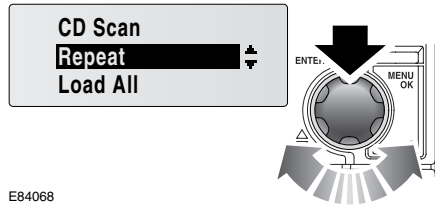

E84068

1. Press the **MENU** button to view the menu.
2. Use the rotary control to select **Repeat** and press the control to enable the function.
3. To disable the function, rotate the menu control to select **Repeat** and press the control. Pressing the **C** button, the next track or previous track buttons will also disable the function.

COMPACT DISC TRACK SCANNING

Compact disc track scan allows you to sample the music on a compact disc. This feature plays the first ten seconds of each track in numerical order. Play will then begin at the start of track one.

CD scan - Premium audio

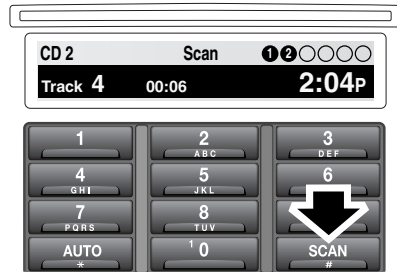

E82983

Press the **SCAN** button to enable this function.

Compact disc player

To disable the function, and to continue the currently playing track, press the **SCAN** or **EXIT** button again.

Note: While in CD scan mode, pressing the previous track button will resume normal play at the current track. Pressing the next track button will move to the next track and resume normal play.

CD Scan - Standard audio

1. Press the **MENU** button to access the functions menu.
2. Use the rotary control to select **CD Scan**.
3. Press the rotary control to enable or disable the function.

Note: While in CD scan mode, pressing the previous track button will resume normal play at the current track. Pressing the next track button will move to the next track and resume normal play.

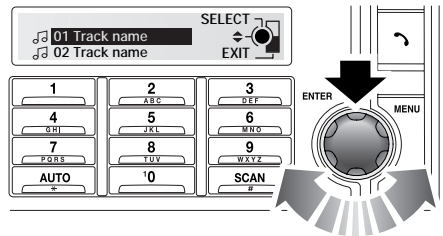
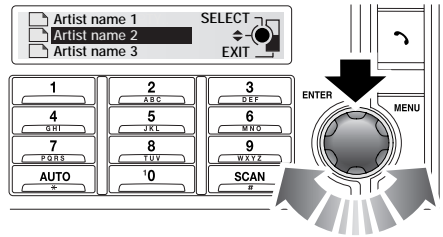

E83753

If you wish to navigate through folders to select specific tracks, press the rotary control to access the file structure. Use the rotary control to highlight the required folder or track and press to select.

If an MP3 recording is made with a compression rate lower than 128k some Digital Signal Processing (DSP) functionality may be lost.

To make sure that the best sound quality is achieved the instructions or information provided with the recording software should be read carefully and adhered to.

MP3 FILE PLAYBACK

Note: Standard audio units do not have the facility to play MP3 files.



E82984

When a data disc (containing MP3 encrypted music data) is inserted into the compact disc slot, **MP3** will appear at the top of the display. The disc will play the tracks in the order they appear on the disc.

All folder information is ignored and the tracks are numbered as they are ordered.

Auxiliary input (AUX IN) socket

AUXILIARY INPUT (AUX IN) SOCKET

WARNINGS

 Make sure that any auxiliary devices are stored securely while the vehicle is in motion. Any loose objects can present a serious hazard during sudden manoeuvres, emergency braking or an accident.

 Do not place any item connected to the auxiliary input socket or the auxiliary power socket on the vehicle's seats, carpets, or other upholstery. The heat generated by these devices may cause damage to the upholstery, or in extreme cases, a vehicle fire.

 Do not leave any auxiliary input devices connected while the vehicle is left unattended. There is a risk of heat damage or fire, in addition to the risk of theft.

CAUTION

 Read the manufacturer's instructions for any device before it is connected to the vehicle's audio system. Keep to any instructions about connection and operation and make sure that the device is suitable. Failure to do so may result in damage to the vehicle's audio system or the auxiliary device.

AUX (Auxiliary Input) mode allows extra equipment to be connected to the vehicle's audio system. Items such as a personal stereo, MP3 player, hand-held navigation unit etc., can be plugged in to the vehicle's audio system.

Note: *The volume levels and sound quality available from devices connected to the auxiliary inputs may vary widely. If the connected audio device is equipped with a line out socket as well as a headphone socket, the line out socket should be used.*

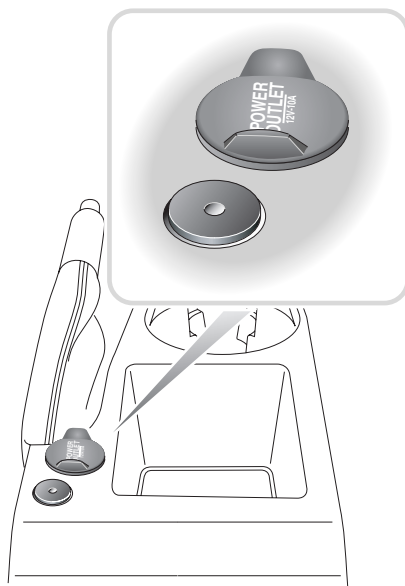

E83104

The auxiliary connector is situated at the rear of the centre console.

Auxiliary audio devices are connected via the 3.5 mm stereo jack socket.

The auxiliary power socket, situated next to the auxiliary input connector, can be used to power or charge any suitable device.

Auxiliary input (AUX IN) socket

Auxiliary mode

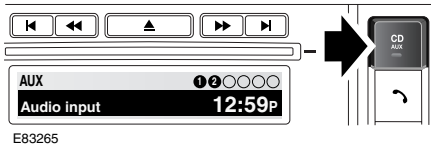

To listen to an auxiliary input source, connect the device and press and hold the **CD or AUX** button on premium audio units. On standard audio units, press and release the **AUX** button. The unit will playback audio via the 3.5 mm stereo jack socket.

Alternatively, repeatedly press the **MODE** button on the steering wheel or the rear audio controls until **AUX** is selected.

Rear passenger controls

REAR SEAT CONTROLS

The rear seat control panels, located on the rear of the centre console, provides control of the audio system to the rear seat passengers.

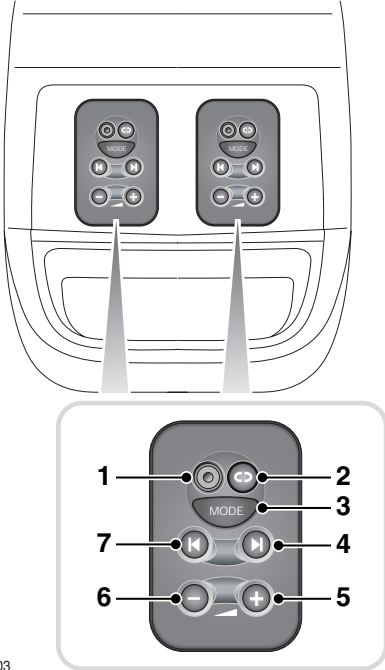

E83103

1. 3.5 mm headphone socket
2. CD select
 - During CD play, press and release to select the next CD.
3. Mode control
 - Repeatedly press to scroll through FM, AM, CD and AUX modes.
4. Search up
 - During radio play, press to search up the frequency band for the next station with a good signal strength.

5. Volume increase
 - Press to increase headphone volume
6. Volume decrease
 - Press to decrease headphone volume
7. Search down
 - During radio play, press to search down the frequency band for the next station with a good signal strength.
 - During CD play, press and release to start the current track again. A second press will start the previous track.
 - During CD play, press and hold to search back through the track being played. Release button to stop search.

With the starter switch in position I or II, the rear seat controls can operate, regardless of whether the audio system is switched on or not. The play and selection features of the audio system will be available at the rear seat controls. However, the output can only be heard through the headphones.

If rear seat passengers are listening to the same source as the front seat passengers, only the volume can be adjusted at the rear seat controls.

For example, if a music CD is playing on the audio unit, rear seat passengers can listen to that music and adjust the volume to suit their requirement. No other functions will be available.

Rear passenger controls

If however, the audio unit is switched to another source, e.g. radio, all CD related rear seat controls become operable. If the audio source is subsequently switched back to CD, the rear seat controls will again be limited to volume control only.

The same logic applies to radio functions.

Adjustments can be made to other functions of the audio system.

For example, if a music CD is selected on the audio unit, radio can be selected and controlled using the rear seat controls. All radio related rear seat controls become operable.

HEADPHONES

Note: Only headphones compatible with a 3.5 mm jack plug socket can be used. To obtain optimum sound quality, use headphones with an impedance of 32 ohms.

Note: When the headphones are not connected, the rear seat controls remain operational. It is still possible to select CD, while the radio is playing on the audio unit. CD play will remain operational until the mode control is pressed again.

Note: The mode in use when the starter key is removed will resume if the starter switch is turned on again (position **I** or **II**) within two minutes. If the starter switch is turned off for longer than two minutes **AUX** mode will be selected when the starter switch is next turned on. For example, if a CD is playing when the key is removed, play will restart when the starter switch is next turned to position **I**, or the engine is started, whether the headphones are in use or not.

Note: Adjusting the volume on the audio unit, does not alter the headphone volume. The volume of each controller can be adjusted independently.

Telephone

GENERAL INFORMATION

WARNINGS



Using the telephone near the car: do not telephone inside a garage or near an open car bonnet. The air may contain fuel vapours and the telephone could produce sparks and start a fire.



Unusual ambient conditions: Switch off the telephone in areas where high explosives are being used. High frequency remote controls could be interfered with and cause an explosion. Switch off your telephone in areas with a high explosion risk. This includes filling stations, fuel storage areas or chemical factories, as well as places where the air contains fuel vapour, chemicals or metal dust. The telephone might possibly produce sparks and cause a fire or explosion.



Medical equipment: The functioning of cardiac pacemakers or hearing aids may be impaired when the phone is in use. Check with a doctor or manufacturer whether any such devices you or your passengers are using are sufficiently protected against high-frequency energy.



Always stow your mobile phone securely. In an accident loose items can cause injury.

Note: *The vehicle telephone system is designed to function with a wide variety of Bluetooth telephones. As these telephones have a wide range of audio and echo performance characteristics, it may take a few seconds for the vehicle telephone system to adapt and deliver optimum audio performance. It may be necessary to reduce the in-vehicle volume slightly to fully optimise audio performance and reduce echo.*

Note: *The vehicle's Bluetooth telephone system can be used with an appropriate Bluetooth-equipped mobile telephone.*

Note: *Please refer to your Land Rover Dealer/Authorised Repairer for a list of compatible telephones.*

Telephone networks

The Telephone network standard allows you to use your telephone in many countries.

However, telephone reception may be poor or unavailable in remote regions. This may be due to the inadequate power of the transmitter, which results in a weak signal or incomplete coverage.

Telephone

TELEPHONE CONTROLS

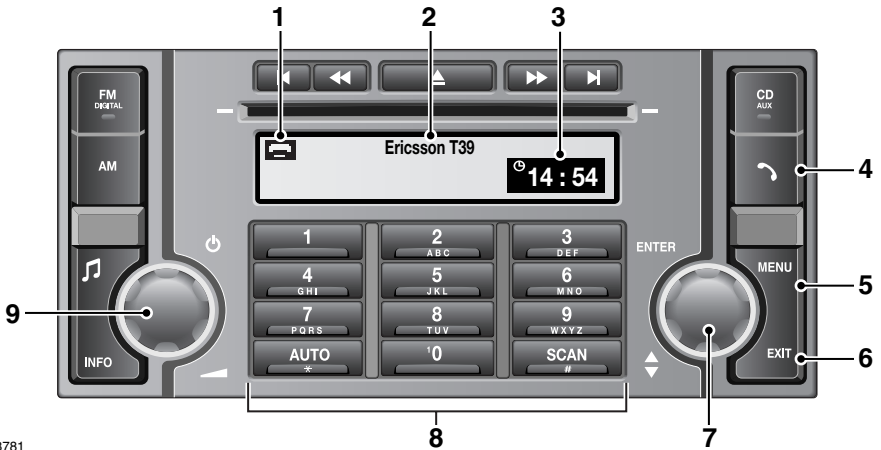

E83781

1. Call status icon
 - Indicates whether the telephone is in use.
2. Paired telephone name
 - The name of the telephone which is paired to the vehicle system.
3. Clock
4. Telephone mode button
 - Press to enable operation of telephone. (Press and hold to switch telephone operation off).
5. **MENU** button
 - Press to enter the telephone main menu.
6. **EXIT** button
 - Press to exit a menu or to delete entered numbers.
7. **ENTER** button
 - Rotate to select menu options. Press to confirm selections.
8. Keypad
 - Use to enter numbers. Also used to select phonebook letters.
9. On or off or volume button
 - Rotate (when in Ring Volume menu) to adjust the ring volume.

Telephone

Telephone controls - Steering wheel

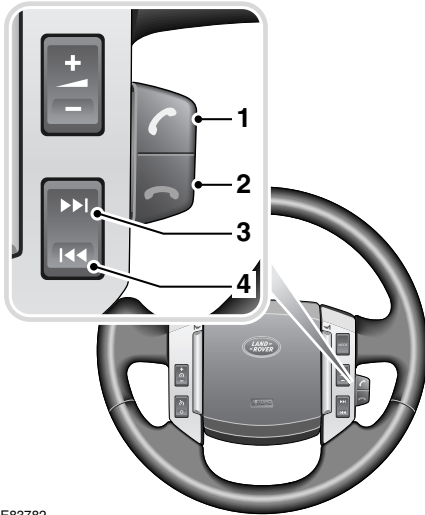

E83782

1. Answer call or dial switch
 - Pull the switch towards the steering wheel to answer an incoming call, or to view the list of the last 10 dialed numbers (if the audio unit is in telephone mode). A second pull of the switch will dial the highlighted number. Pull and hold the switch (for approximately two seconds) to activate voice tag dialling. See **TELEPHONE VOICE CONTROL** (page 270).
2. End or reject call switch
 - Pull the switch towards the steering wheel to end the current call or reject an incoming call.
3. Menu next button
 - Press to scroll down through a menu.
4. Menu previous button
 - Press to scroll up through a menu.
5. To leave the menu press the **EXIT** button.

BLUETOOTH SETUP

Before you can use your telephone with your vehicle it must be paired to the vehicle telephone system.

When pairing a Bluetooth telephone with the vehicle system make sure that the telephone is switched on, Bluetooth is enabled and discoverable, its battery is fully charged and the telephone User's Handbook is available.

***Note:** A maximum of five pairings can be made to the vehicle, but only one telephone can be used at any time.*

Pairing a telephone to the system

Your Bluetooth mobile telephone pairing or discovery process will also be described in your mobile telephone User's Handbook.

1. Make sure the telephone to be paired is within 10 metres (30 feet) of the vehicle.
2. With the vehicle ignition on, press the telephone mode button on the audio unit. The system will search for the last connected telephone. If a telephone is not detected, the system will ask if you want to pair. Briefly press the **ENTER** button. If you do not want to pair a telephone, press the **EXIT** button.
3. The audio unit display will show a message to make sure that your Bluetooth telephone is switched on. Briefly press the **ENTER** button. The system will then start a search for your telephone.
4. After the search is completed, a list of all telephones found will be displayed on the audio unit screen. If more than one telephone is found, rotate the **ENTER** button to move up or down the list to select your telephone and then press the **ENTER** button.

Telephone

5. The audio unit will now display a Bluetooth access code number which must be entered into your telephone.
6. A message on the audio unit display will confirm the system is connecting with your telephone. When it is successfully connected, the telephone will be paired and connected with the vehicle and can now be used with the vehicle telephone system.
7. If the pairing fails, a message will appear on the audio unit display; press the **ENTER** button to retry or press the **EXIT** button and restart the process.
8. The last connected telephone will be available for use when the system and telephone are switched on again.
9. If you wish to pair additional telephones, repeat the process.
3. Select a telephone by rotating the **ENTER** button, highlight the telephone to be removed then press the **ENTER** button. A confirmation message to remove a telephone will appear on the audio unit display, press the **ENTER** button.
4. The **remove telephone** screen will be displayed, and if no further telephones are to be removed, press the **EXIT** button.

Loss of Bluetooth link

If the link between the telephone and the vehicle is lost, you have the choice to reconnect or to exit from the telephone system. To reconnect press the **ENTER** button. There will be a short delay whilst the connection is established and then your telephone name will be shown in the display.

Alternatively, press the **EXIT** button if you do not wish to reconnect your telephone.

Adding or changing a telephone

1. Select the telephone main menu. See **TELEPHONE SETUP** (page 258).
2. Select **Bluetooth**, then select the option to **change a telephone**.
3. **Add new phone** will appear at the top of the list. Repeat the procedure for pairing a telephone to the system.

If the maximum number of telephones are already paired to the system, a message will be displayed and you are given the option to remove one. This must be carried out before a new telephone can be paired.

Removing a telephone from the system

1. Select the telephone main menu. See **TELEPHONE SETUP** (page 258).
2. Select **Bluetooth**, then select the option to **remove a telephone**.

Telephone

TELEPHONE SETUP

Telephone main menu



E83808

Press the **MENU** button then rotate the **ENTER** button to select from:

- Missed calls
- Received calls
- Dialled calls
- Phonebook
 - See **PHONEBOOK** (page 266).
- Bluetooth
 - See **BLUETOOTH SETUP** (page 256).
- Phone settings
- Clock
 - See **CLOCK** (page 107).

Press the **ENTER** button to confirm your selection.

Missed calls

The audio unit display will list the numbers of the last 10 calls which have been missed. These are displayed in chronological order, with the last number missed first and highlighted.

Note: Some mobile telephones reverse the missed call list, which results in the last missed call number being at the bottom of the list, rather than the top.

Rotate the **ENTER** button to select the number, then press again or operate the answer call switch on the steering wheel to dial the number.

If there are no entries, an empty list is shown, press **EXIT** to return to the phone view.

Note: When viewing missed calls, do not rotate the volume button as this will result in your highlighted selection returning to the first entry in the list, irrespective of your previously highlighted position.

Received calls

The audio unit display will list the numbers of the last 10 calls which have been received. These are displayed in chronological order, with the last number received first and highlighted.

Note: Some mobile telephones reverse the received call list, which results in the last received call number being at the bottom of the list, rather than the top.

Rotate the **ENTER** button to select the number, then press again or operate the answer call switch on the steering wheel to dial the number.

If there are no entries, an empty list is shown, press **EXIT** to return to the phone view.

Telephone

Note: When viewing received calls, do not rotate the volume button as this will result in your highlighted selection returning to the first entry in the list, irrespective of your previously highlighted position.

Dialled calls

The audio unit display will list the numbers of the last 10 calls which have been dialled. These are displayed in chronological order, with the last number dialled first and highlighted.

Note: Some mobile telephones reverse the dialled call list, which results in the last dialled call number being at the bottom of the list, rather than the top.

The dialled calls list can also be accessed by pressing the **ENTER** button, when telephone mode is selected.

Rotate the **ENTER** button to select the number. Then to dial the number, press **ENTER** again, or operate the answer call switch on the steering wheel.

If there are no entries, an empty list is shown, press **EXIT** to return to the phone view.

Note: When viewing dialled calls, do not press the volume button as this will take you back to the radio or CD.

Phone settings

Select **Call options** from the **Phone Settings** menu, and press the **ENTER** button.

Call options



E63809

This feature is used to turn the automatic answer facility on or off and also to enter the voice mail number.

Rotate the **ENTER** button to highlight **Automatic answer** and press the **ENTER** button. Select **On** and press the **ENTER** button again.

When automatic answer is on, all incoming calls are answered automatically and when the mode is off you must accept the call or press **EXIT** to reject.

To enter a voice mail number, rotate the **ENTER** button to highlight **Voicemail number** and press the **ENTER** button. Enter your voice mail number on the keypad and press the **ENTER** button again.

Use the **EXIT** button to delete an incorrect number.

Telephone

Sounds and alerts



E83810

Selecting sounds and alerts gives you the choice to alter the ring tone and the ring volume.

*This only applies to the **Car ring tones**. If **Mobile ring tone** is selected, no ring tone will be played. When **Mobile ring tone** has been selected, the volume can only be changed when there is an incoming call, i.e. ringing.*



E83811

To select the ring volume, rotate the **ENTER** button to highlight **Ring volume** and then press the **ENTER** button to select. Now by rotating the **On or off or volume** button you can change the ring volume.

Note: If the ring volume is not changed, the ring tone will sound for eight seconds. If the ring volume is changed, the ring tone will return to the menu two seconds after the change has been made.



E83812

Select ring tone by rotating the **ENTER** button to highlight **Ring tone** and then press the **ENTER** button to select. Rotate the **ENTER** button to select one of the four alternative ring tones, or use the mobile telephone ring tone. Once you have selected a ring tone, press the **ENTER** button to hear the selected ring tone.

Note: This only applies to the **Car ring tones**. If **Mobile ring tone** is selected, no ring tone will be played. When **Mobile ring tone** has been selected, the volume can only be changed when there is an incoming call, i.e. ringing.

Telephone

Another brief press of the **ENTER** button will store the tone. If you press the **EXIT** button the tone will not be stored and the ring tone menu will remain visible. Press the **EXIT** button again to return to the main menu or to the function previously selected.

Note: *Not all mobile telephones support **Mobile ring tone**, in this case it will not be possible to select and store the **Mobile ring tone** setting in the vehicle system.*

Autocopy phonebook

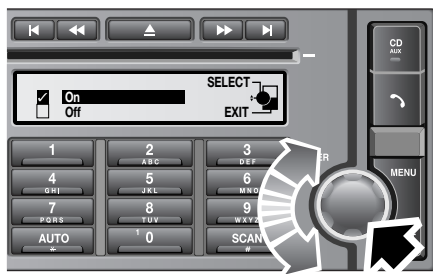

E83813

This feature allows you to choose whether or not your phone book is automatically updated every time you connect your telephone to the vehicle system. If **On** is selected and your telephone has the capability, the vehicle phone book will be updated the next time the telephone is connected to the vehicle. If **Off** is selected the phone book will not be downloaded to the vehicle system. See **PHONEBOOK** (page 266).

Press the **ENTER** button after making your selection. Pressing the **EXIT** button will return you to the previous screen. To return to the telephone main display, press and hold the **EXIT** button.

USING THE TELEPHONE

Selecting telephone mode

Switch on the ignition. If your telephone is switched on and previously paired or connected with the system, you can select the vehicle telephone system.



E83788

Briefly press the telephone mode button (arrowed). Visual confirmation of telephone operation is given via the display.

If a telephone is not paired to your vehicle system, **No paired Phone** and **Do you want to pair?** is displayed. See **BLUETOOTH SETUP** (page 256).

To exit telephone mode, press one of the audio system mode buttons, i.e. **FM**, **AM** or **CD** or **AUX**.

Telephone display

There are four different call status screens:

Telephone

No call

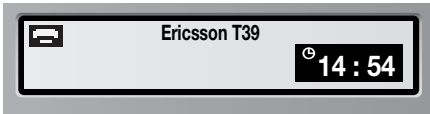

E83789

Dialling

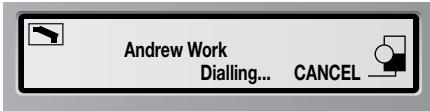

E83790

Incoming call

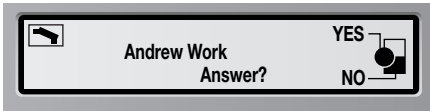

E83791

Call in progress

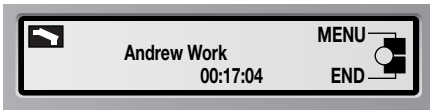

E83792

Making telephone calls

Dialling a number manually

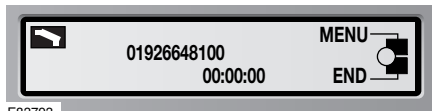

E83793

Enter the telephone number to be dialled, using the vehicle keypad. The digits of the number appear in the display.

To pause during number entry, press and hold the **AUTO** key. A * symbol will appear in the display.

The international dial symbol + can be entered by pressing and holding the **0** (zero) key.

When the telephone number has been entered, briefly press the **ENTER** button or operate the answer call switch on the steering wheel to dial the number (**Dialling** appears in the display supported by ringing tones). A successful connection is shown on the display.

Telephone

Note: To cancel a call at any time, press the **EXIT** button or operate the end call button on the steering wheel.

Correcting or deleting numbers



E83795

If an incorrect digit is entered, press the **EXIT** button (arrowed) to delete the last digit, then enter the correct digit.

Press and hold the **EXIT** button (for approximately two seconds) to delete all entered digits.

Multiple choice dialling

If the number you have dialled has an automated voice that requests another number, for a different area or department, use the keypad to enter that number.

Last number redial

The last number dialled can be redialled using the answer call switch on the steering wheel. If telephone mode is active, pull and release the switch. The number will appear in the audio unit display. Pull and release the answer call switch for a second time and the number will be dialled.

If telephone mode is not active, press the telephone mode button to enter telephone mode.

Note: Some mobile telephones reverse the last dialled number list, which results in the last dialled number being at the bottom of the list, rather than the top.

Ending telephone calls

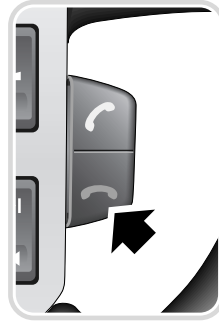

E83796

To end a telephone call, press the **EXIT** button or operate the end call switch on the steering wheel.

Telephone

Receiving telephone calls

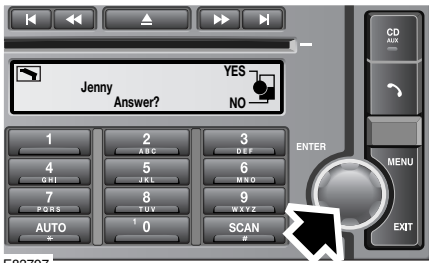
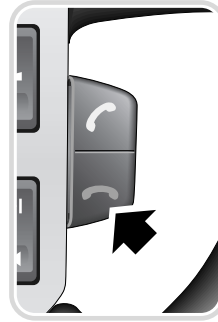

E83797

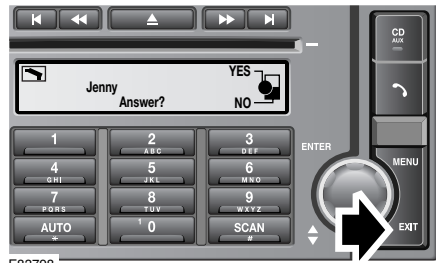

E83798

When a call is received, the number or caller ID (if entered into the phone book) will appear in the audio unit display.

If the audio or a CD was in use before the telephone call then that function will resume at the end of the phone call. A CD will continue playing from the point at which it was paused by the telephone call. The telephone display will be visible for the duration of the call.

The call can be answered in two ways:

- Operate the answer call switch on the steering wheel (arrowed in inset).
- Briefly press the **ENTER** button (arrowed).

If automatic answer is switched on, the call is accepted automatically. If automatic answer is switched off, and you do nothing, the vehicle system will operate as your mobile telephone would operate, i.e. go to voice mail or continue ringing.

Note: The automatic answer feature can be switched on or off. See **TELEPHONE SETUP** (page 258).

When the call is accepted, the display shows that the call is in progress and the duration of the call in minutes and seconds.

Rejecting an incoming call

To reject a call without answering, briefly press the **EXIT** button or operate the end call switch on the steering wheel.

Telephone

Telephone in-call menu

A number of settings can be made while a call is in progress. These are:

- muting the call
- privacy call
- accessing the phonebook.

When the call is ended the in-call settings return to their default values.

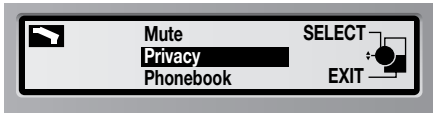
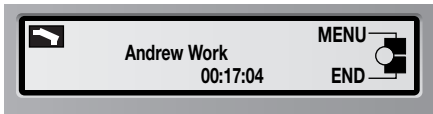

E83801

To enter the in-call menu, press the **MENU** button and then rotate the **ENTER** button to highlight the required option. Press the **ENTER** button to select.

Mute the call

Select **Mute** and press the **ENTER** button, this will prevent the caller from hearing any conversation in the vehicle.

Select **Mute Off** and press the **ENTER** button to resume your telephone conversation.

Privacy mode

Select **Privacy** and press the **ENTER** button, this will transfer the call to the mobile telephone preventing the vehicle occupants from listening in to your received conversation.

Select **Hands Free** and press the **ENTER** button when you wish to return to using the vehicle system.

***Note:** Some mobile telephones may end the call or lose the Bluetooth connection when transferring between Privacy and Hands Free modes.*

Phone book

You can access your phone book during a telephone conversation if you need to find a particular number.

Select **Phonebook** and press the **ENTER** button.

Press the **EXIT** button to return to your telephone conversation.

Telephone

Voice mail

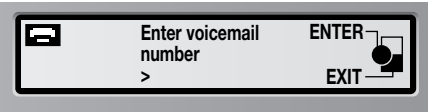

E83804



You can access your voice mail when the mobile telephone is switched on, the voice mail number has been stored in the vehicle system and the vehicle system is in telephone mode. Press and hold the number **1** key on the keypad. This will send a message to the mobile telephone to dial the voice mail number.

You can also access voice mail by using **Call options** in the **Phone Settings** menu. See **TELEPHONE SETUP** (page 258).

The audio unit display will indicate when voice mail is empty.

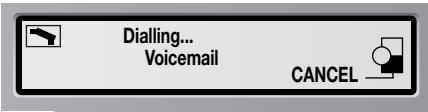

E83803

Voice mail may be set up by your service provider and can be used by the vehicle system.

Before voice mail can be used in the vehicle system, the voice mail number needs to be entered. See **TELEPHONE SETUP** (page 258).

PHONEBOOK

When your telephone is next connected to the vehicle and autocopy phonebook is set to **On**, your phonebook is downloaded automatically to the vehicle system, provided your telephone has the capability. See **TELEPHONE SETUP** (page 258).

Note: If there is a communication problem with the telephone or the telephone does not support this feature, the message **Phonebook is empty** will be displayed, and the phonebook will not be downloaded.

Telephone

Once downloaded, the phonebook can be accessed through the telephone main menu.

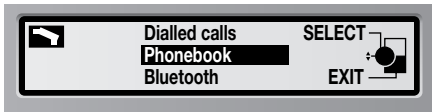

1. Press the **MENU** button to access the telephone main menu.
2. Rotate the **ENTER** button to highlight **Phonebook** and press the **ENTER** button again to select.

Note: To exit the phonebook without selecting an entry, press the **EXIT** button.

Phonebook menu

Rotate the **ENTER** button to select one of the following options:

- Search Phonebook
- Copy from Phone
- Erase car entry
- Erase car Ph.book

Press **ENTER** to confirm your selection.

Search Phonebook

Note: When viewing the phonebook, do not rotate the volume button as this will result in your highlighted selection returning to the first entry in the phonebook, irrespective of your previously highlighted position.

The following methods can be used to search the phonebook:

- browsing
- alphabetic search
- quick search

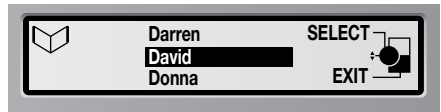

Browsing the phonebook

1. With phonebook displayed, rotate the **ENTER** button clockwise, or operate the menu next button on the steering wheel to scroll down the phonebook. To scroll up the phonebook, rotate the **ENTER** button counterclockwise or press the menu previous button on the steering wheel.
2. Once the chosen phonebook entry is highlighted, press the **ENTER** button, or operate the answer call switch on the steering wheel, to dial the number.

Telephone

3. If an entry was selected by mistake, either operate the end call switch on the steering wheel, or press the **EXIT** button to cancel dialling.

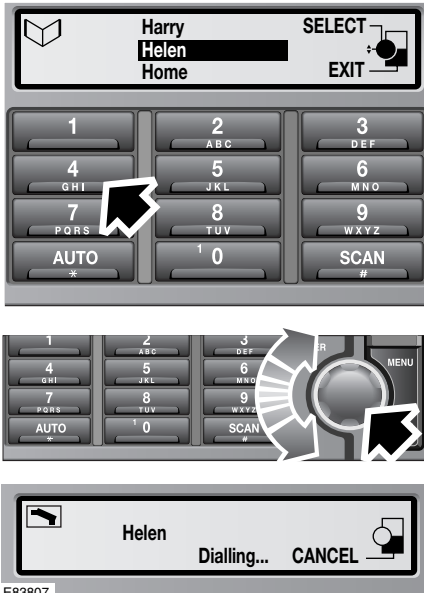

2. If there are a large number of entries beginning with the letter **H**, the second and subsequent characters of the name can be added by repeatedly pressing the relevant key until the character appears in the audio unit display.
 - For example; if the required phonebook entry is **Helen**, press the **4** key on the keypad twice the **2** key on the keypad twice, and the **5** key on the keypad three times. The display will now show all entries beginning with **Hel**.
3. Once the chosen phonebook entry is highlighted, press the **ENTER** button, or operate the answer call switch on the steering wheel, to dial the number.

Alphabetical search

1. With the phonebook displayed, press the appropriate key the corresponding number of times according to the initial letter of the entry.
 - For example; if the initial letter of the required phonebook entry is **H**, press the **4** key on the keypad twice. The display will now show all entries beginning with the letter **H**.

Telephone



E83840

Quick search

1. To find a specific number from your phonebook without accessing the phonebook, while in telephone mode, press and hold a key (between **2-9**) which corresponds to the first letter of the name.
 - For example; if the initial letter of the required phonebook entry is an **M**, press and hold the **6** key of the keypad. The phonebook will open at the selected point.
2. If there are a large number of entries beginning with letter **M**, the second and subsequent characters of the name can be added by repeatedly pressing the relevant key until the character appears in the audio unit display.
 - For example; if the required phonebook entry is **Mark**, press the **2** key on the keypad once and the **7** key on the keypad three times. The display will now show all entries beginning with **Mar**.

3. Once the chosen phonebook entry is highlighted, press the **ENTER** button, or operate the answer call switch on the steering wheel to dial the number.

Copy from phone

If the phonebook in the vehicle system does not match that of the mobile telephone (and your mobile telephone supports this feature), the following procedure will allow you to resynchronise.

Note: The vehicle system phonebook allows 750 entries to be downloaded. If your mobile telephone contains more than this, the mobile telephone will send these in memory location order. Which means that your telephone phonebook may not always match the vehicle system.

1. Enter the phonebook menu and select **Copy from Ph. book**. Press the **ENTER** button to confirm.
2. If successful, **Phonebook downloading to the car is in progress** will appear on the display.
3. On completion of the download, the display will return to the telephone main menu.

If the phonebook download is not supported, the message **Phonebook download is not supported by this phone** will appear in the display.

Erase car entry

Once a phonebook has been downloaded, individual entries can be erased from the vehicle system, not from the mobile telephone.

Note: If Autocopy phonebook is switched on, the next time the telephone is connected to the vehicle system, the mobile telephone's phonebook will be sent to the vehicle. This may result in your previously deleted entry being re-instated in the vehicle system phonebook.

Telephone

1. Enter the phonebook menu and select **Erase car entry**.
2. Press the **ENTER** button to confirm.
3. Rotate the **ENTER** button to select the entry you wish to erase and press the **ENTER** button.
4. A confirmation message will appear on the display. Press the **ENTER** button to erase the entry or press the **EXIT** button to retain the entry and return to the menu.

Erase car Ph. book

Once a phonebook has been downloaded, it can be erased from the vehicle system, not from the mobile telephone.

Note: If Autocopy phonebook is switched on, the next time the telephone is connected to the vehicle system, the mobile telephone's phonebook will be sent to the vehicle. This may result in your previously deleted phonebook being re-instated in the vehicle system.

1. Enter the phonebook menu and select **Erase car Ph. book**. Press the **ENTER** button.
2. A confirmation message will appear on the display. Press the **ENTER** button to erase the phonebook or press the **EXIT** button to retain the phonebook and return to the menu.

TELEPHONE VOICE CONTROL

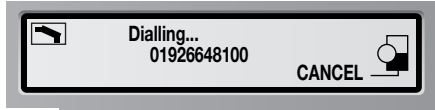
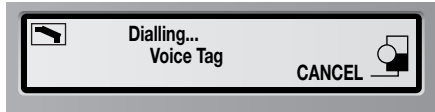
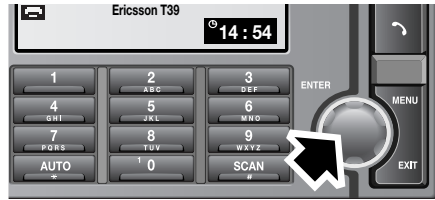

E83802

The vehicle system is able to use any voice tags which are stored in the mobile telephone.

Note: Voice tags are stored via the mobile telephone and should be set up without the mobile telephone connected to the vehicle.

1. Press and hold the **ENTER** button, or pull and hold the answer call switch on the steering wheel to access voice tag dialling.
2. The phone display will show that voice tag dialling is in progress and, after an audible prompt from your mobile telephone, you should recite the name that you want to call.
3. A message on the audio unit display will confirm your voice tag and the number is then dialled.
4. If the name you requested is not recognised then you will be informed.
5. Press the **EXIT** button to cancel voice tag dialling.

Index

A

ABS driving hints	123
Accessories	37
Adaptive front lighting system (AFS)	74
Adjusting the headlamps	73
Adjusting the steering wheel	70
Adjusting the windscreen washer jets	89
Blocked jets	90
Front	89
Rear	89
AFS	74
Air vents	101
Airbag service information	63
Airbag warning lamp	61
Alternative frequencies	229
Alternative Frequency (AF) - Premium audio	230
Alternative Frequency (AF) - Standard audio	230
Approach lamps	76
Arming the alarm	45
Alarm indicator	45
Full alarm	45
Partial alarm	45
Ashtray	109
Audio control	70, 223
Audio control using the telephone buttons	71
Balance adjustment	224
Bass response adjustment	223
Centre speaker settings	224
Fader adjustment	224
Resetting tone values	224
Subwoofer settings	224
Surround sound settings	223
Treble response adjustment	223
Audio controls	235
Audio unit overview	219
Basic audio functions	222
Premium audio overview	219
Standard audio overview	221
Automatic climate control	103
Controls	103

Automatic transmission	118
Automatic mode	119
Electronic gear change strategies	120
Sport mode and CommandShift™	120
Autostore control	225
Autostoring radio stations - Premium audio	225
Autostoring radio stations - Standard audio	225
Auxiliary heater	104
Auxiliary input (AUX IN) socket	250
Auxiliary mode	251
Auxiliary power sockets	110

B

Battery care	171
Battery charging	174
Battery warning symbols	171
Bluetooth setup	256
Adding or changing a telephone	257
Loss of Bluetooth link	257
Pairing a telephone to the system	256
Removing a telephone from the system	257
Bonnet lock	160
Booster cables	173
Booster cushions	66
Brake and clutch fluid check	165
Checking the fluid level	165
Topping up the fluid	166
Brakes	
Principle of operation	123
Bulb changing	77
Bulb specification chart	86
C	
Car wash	154

Index

Changing a bulb	77	Cleaning the exterior	154
Front fog lamp	81	Cleaning after off-road driving	155
General information	77	Washing the vehicle	154
Headlamp unit bulbs	79	Cleaning the interior	155
High level brake lamp	83	Airbag module covers	156
Interior lamp bulbs	85	Carpets and fabrics	156
Number plate lamp bulb	84	Instrument pack, clock, and audio equipment	156
Rear lamp bulbs	82	Leather	155
Removing the headlamp unit	78	Plastic and cloth	155
Removing the rear lamp unit	82	Seat belts	156
Side repeater lamp	84	Clock	107
Changing a fuse	195	Setting the clock - Premium audio	107
Changing a road wheel	183	Setting the clock - Standard audio	108
Locking wheel nuts	187	Compact disc display options	247
Positioning the jack	185	Compact disc function menu	247
Temporary spare wheel	186	Compact disc pause	246
Tool kit	186	Compact disc playback	246
Wheel changing safety	184	Compact disc selection	246
Wheel nut tightening sequence	186	Compact disc track scanning	248
Changing the vehicle battery	174	CD scan - Premium audio	248
Battery disposal	175	CD Scan - Standard audio	249
Disconnecting	174	Coolant check	163
Effects of disconnecting	175	Cruise control	130
Refitting	175	Principle of operation	130
Replacement batteries	175	Cup holders	111
Changing the wiper blades	90	D	
Changing the front wiper blades	91	Diesel particulate filter (DPF)	116
Changing the rear wiper blades	92	Regeneration	116
Service position	90	Warning indicators and messages	117
Channel automatic tuning	236	Digital audio broadcasting	
Channel options	236	General information	234
Scanning channels	238	Dimensions	213
Selecting a channel	237	Clutch and brake pedal travel (China only) . 214	
Selecting a subchannel	237	Wheel alignment data (China only)	214
Selecting an ensemble	237	Direction indicators	75
Signal availability	238	Disabling the passenger airbag	62
Charging the vehicle battery	174	Operational status indicator	63
Checking the wiper blades	90	Disarming the alarm	46
Child safety locks	69	Deactivating the alarm when triggered	46
Child seats	64	Disarming when the unlock button fails to work	46
Child restraint check list	65	Display options	236
Cigar lighter	109	DPF	116
Cleaning the alloy wheels	154		

Index

- Driving after a collision 205
 Before starting or driving 205
 Resetting the fuel cut-off 205
 When driving 205
- E**
- Economical driving 129
 Driving tips for economy 129
 Maintenance and fuel economy 129
- Ejecting compact discs 246
- Ejecting multiple compact discs 246
- Electric exterior mirrors 95
 Adjusting and folding 95
 Mirror dip when reversing 96
- Electric seats 49
 Driving position memory 50
- Electric sunroof 105
 Anti-trap mechanism 105
 Calibration 106
 Operation 105
 Sunroof blinds 106
- Electric windows 93
 One shot operation 93
 Overriding anti-trap protection 93
 Window isolator 94
 Window reset 94
- Engine compartment overview 161
1. Engine oil filler caps (Black) 161
 2. Engine oil dipsticks (Yellow) 161
 3. Brake fluid reservoir cap (Black) 161
 4. Coolant reservoir cap (Black) 161
 5. Washer fluid reservoir cap (Blue) 161
 6. Power steering fluid reservoir cap (Black) 161
- Engine coolant check 163
 Checking the coolant level 163
 Topping up the coolant 164
- Engine oil check 162
 Checking the oil level 162
 Engine oil specification 163
 Topping up the oil 163
- Engine specifications 211
- Enhanced other network (RDS-EON) 229
- Essential towing checks 151
- Event data recording 37
- Exterior mirrors 94
 Proximity mirror (Japan only) 94
- F**
- Fast forward/reverse 247
- Fastening the seat belts 56
 Releasing the seat belts 56
- Filling station information 33
 Engine coolant specification 34
 Engine oil specification 34
 Fuel filler flap 33
 Tyre pressures 34
- Front fog lamps 72
- Fuel and refuelling 146
 Technical specifications 146
- Fuel burning heater 104
- Fuel consumption 146
- Fuel cut-off 144
 Resetting the fuel cut-off 144
- Fuel filler flap 144
- Fuel quality 142
 Alternative fuels for petrol engines 143
 Diesel engined vehicles 143
 Petrol engined vehicles 142
- Fuse box locations 195
- Fuse specification chart 196
 Engine compartment fuse box 196
 Luggage compartment fuse box 201
 Passenger compartment fuse box 199
- G**
- General driving points 128
 Battery charging - red 128
 Low oil pressure - red 128
- General information on radio frequencies 40
- H**
- Handbrake 124
- Hazard warning flashers 74, 204
- HDC 137
- Head restraints 51
- Headlamp adjustment 73
- Headlamp levelling 73
 Halogen headlamps 73
 Xenon headlamps 73
- Headlamp washers 88
- Headphones 253

Index

Heated seats	53
Heated windows and mirrors	104
Hill descent control	137
Hill descent control (HDC) Principle of operation	136
Hints on driving with ABS	123
ABS and off-road driving	124
ABS warning indicator	123
Electronic Brake Distribution (EBD)	124
Emergency Brake Assist (EBA)	124
I	
Information messages	99
Main message centre	99
Messages	100
Inspecting safety system components	206
Instrument panel overview	97
Instrument panel	97
Interior lamps	76
Interior mirror	96
Auto dimming	96
Manual dimming	96
ISOFIX anchor points	67
Installing an ISOFIX child seat	68
Tether anchorages	68
J	
Jump starting	173
K	
Keys	40
L	
Lashing points	208
Front	208
Rear	208
Levelling	151
Lighting control	72
Headlamp courtesy delay	72
Main beam	72
Main switch panel	72
Load carrying	
General information	147
Loading compact discs	245
Load all	245
Loading a CD - Single disc player	245
Loading a CD - Six disc player	245

Locking and unlocking	44
Drive-away locking	44
Locking and unlocking from inside the vehicle	44
Mis-lock	44
Luggage anchor points	148
Reversible floor	148
Luggage covers	149
Fitting the luggage cover	149
Operating the luggage cover	149

M

Maintenance	
General information	157
Technical specifications	169
Manual climate control	102
Controls	102
Manual seats	48
Manual transmission	118
Mirrors	104
MP3 file playback	249

N

News broadcasts	230
News station preference	230

O

Oil check	162
On or off control	223
Opening and closing the bonnet	160
Closing the bonnet	160
Opening the bonnet	160

P

Parking aid	127
Principle of operation	126
Parking brake	124
Applying the parking brake	125
Parking on a slope	124
Releasing the parking brake	125
Phonebook	266
Phonebook menu	267
Power steering fluid check	166
Checking the fluid level	166
Topping up the fluid	167

Index

Preset buttons	238
Recalling a preset channel	239
Scrolling through presets	239
Storing channels as presets	238
Principle of operation	
Airbag deployment effects	61
Airbag operation	60
Airbags	59
Before driving off-road	136
Brake pads	123
Deployment and deflation	60
Dynamic Stability Control (DSC)	140
Gradient release control (GRC)	136
Introduction	58
Roll stability control (RSC)	140
Seat belt checks	55
Seat belt safety	54
Seat belts	54
Wet conditions	123
Priority programme type (PTY)	231
PTY search - Premium audio	232
PTY seek - Standard audio	233
PTY selection - Premium audio	231

Q

Quick start	7
Audio system	27
Automatic transmission	23
Bonnet	9
CD autochanger	30
CD OPERATION	30
Clock setting	31
Cruise control	24
DAB radio	29
Driving position memory	10
Engine starting	8
Exterior lighting	22
Facia	17
Gearshift interlocks	23
Heating and ventilation	14
Hill Descent Control (HDC)	25
Instrument pack	19
Manual seat adjustment	11
Master lock and unlock switches	9
Overhead console	12
Parking aid	26
Passenger airbag deactivation	13
Power operated seat adjustment	10
Radio operation	29
Remote control	7
Seat belts and Child restraints	13
Single CD player	30
Steering column adjustment	12
Steering column lock	12
Tailgate	9
Telephone - Bluetooth system	31
Terrain Response system	25
Warning indicators (attention)	21
Warning indicators (information)	21
Windows and Door mirrors	11
Wipers and washers	22

R

Radio data system (RDS)	228
Selecting RDS	228
Radio reception	218
Rain sensor	87
Operation	88
Rear fog lamps	73

Index

Rear seat controls	252	Starting a diesel engine	115
Rear seats	51	Automatic transmission	115
Folding the rear seats	52	Manual transmission	115
Raising the rear seats	53	Stopping the engine	116
Rear window wiper and washers	89	Starting a petrol engine	114
Reversing	89	Starting	114
Wash/wipe	89	Stopping the engine	114
Wiper	89	Starting the engine	
Recommended towing weights	152	General information	113
Reduced engine performance	128	Station preset buttons	226
Check engine - petrol models only	128	Storage compartments	112
Engine management system (EMS) fault	128	Sun visors	107
Refuelling	145	Sunroof	105
Fuel filler	145	Supplementary restraints system	
Regional mode (REG)	228	Principle of operation	58
Regional mode - Premium audio	228	T	
Regional mode - Standard audio	229	Technical specifications	
Remote control	41	Accessory wheels and tyres	194
Repairing minor paint damage	156	Capacities	170
Repeat compact disc tracks	248	Fuel consumption	146
Resetting the audio unit	233	Fuel specification	146
Running out of fuel	144	Lubricants and fluids	169
Running-in	128	Transmission fluids and capacities	122
S		Telephone	261
Safety	36	General information	254
Safety precautions	142	Telephone controls	255
Seat belt height adjustment	56	Telephone controls - Steering wheel	256
Seat belt reminder	55	Telephone setup	258
Seat belts		Dialled calls	259
Principle of operation	54	Missed calls	258
Settings	240	Phone settings	259
Advanced settings	242	Received calls	258
Auto-tune	241	Telephone main menu	258
DAB radio text	241	Telephone voice control	270
DAB search	240	Terrain response	132
FM traffic and news	244	Principle of operation	132
Shuffle/random	247	Tow bar	153
Random selection - Premium audio	248	Tow bar dimensions and mounting points	153
Random selection - Standard audio	248	Towing a trailer	150
Sitting in the correct position	47	Trailer electrical connection	150
Snow chains	192	Towing points	207
Stability control	141	Front and rear towing eyes	207
Principle of operation	140	Towing the vehicle on four wheels	208
		Towing procedure	208

Index

Track selection	246	Using stability control	141
Traction control	139	Deactivating DSC	141
Traffic information control	226	DSC	141
Traffic Programme (TP) preference	227	DSC system fault	141
Transmission		Reactivating DSC	141
Technical specifications	122	Using terrain response	132
Transporting the vehicle	208	Before driving off-road	132
Trip computer	99	Driver override options	132
Type approvals	215	Terrain response messages	134
Declarations of conformity	215	Terrain Response operation	133
Tyre care	177	Using the key	40
Age degradation	178	Using the parking aid	127
Directional tyres	180	Front PDC deactivation	127
Flat spots	182	PDC activation	127
Pressure compensation for ambient temperature changes	182	Sensor care	127
Punctured tyres	178	System fault	127
Replacement tyres	179	Using the remote control	41
Tyre checks	179	Approach lighting	42
Tyre pressures	180	Emergency alarm	43
Tyre wear	178	Locking	42
Tyre glossary	193	Remote battery	43
Terms used	193	Remote control	41
Tyre repair kit	187	Single and double locking	42
Checking the tyre pressure after a repair	191	Tailgate	43
Land Rover tyre repair kit	189	Unlocking	41
Land Rover tyre repair kit safety information	188	Using the telephone	261
Using the Land Rover tyre repair kit	190	Ending telephone calls	263
U		Making telephone calls	262
Using booster cables	173	Receiving telephone calls	264
Disconnecting the cables	173	Selecting telephone mode	261
Using cruise control	130	Telephone in-call menu	265
Engaging cruise control	130	Voice mail	266
Increasing the cruise speed	131	Using traction control	139
Reducing the cruise speed	130	Before driving off-road	139
Suspending cruise control	130	Electronic Traction Control (ETC)	139
Using HDC	137	Using winter tyres	183
HDC operation	137	V	
Selecting HDC	137	Vehicle build date plate	210
Warning messages	138	Vehicle identification number (VIN)	210
Using seat belts during pregnancy	57	Vehicle identification plate	210
Using snow chains	192	Vents	101
		VIN	210
		Volume control	223
		Automatic Volume Control (AVC)	223
		Reset volume settings	223

Index

W

Warning triangle	204
Washer fluid check	167
Topping up the fluid	168
Washing	154
Waveband button	224
Weights	212
Wheels and tyres	
General information	176
Technical specifications	194
Windscreen washers	88
Windscreen wipers	87
Intermittent variable delay	87
Speed-dependent mode	87
Wiper operation	87
Winter tyres	183