

CIRCUIT OPERATION**Coolant Temperature Gauge**

The Coolant Temperature Sensor (X114) has approximately 200 ohms resistance when the coolant temperature is low. As coolant temperature increases, the resistance of the sensor decreases. This varying resistance causes the current through the sensor to change and the gauge to register the temperature. When the coolant is hot, the resistance of the sensor is approximately 10 ohms.

Fuel Gauge

When the fuel tank level is low, the resistance of the fuel gauge sender is approximately 220 ohms. As the fuel level increases, the resistance of the sender decreases, causing the gauge to register the change. When the fuel tank is full, the resistance of the sender is approximately 10 ohms.

Speedometer

The Vehicle Speed Sensor (X190) sends a signal to the speedometer in the form of voltage pulses. The pulses are filtered by the Vehicle Speed Sensor Buffer (Z160) (if equipped). The voltage alternates between battery voltage and 0 volts 6 times per wheel revolution. If equipped, the speed sensor signal is also sent to the Seatbelt And Speed Warning Unit (Z156), Cruise Control ECU (Z121), Fuel Injection ECU (Z132), Memory Seat ECU (Z146) and the Emissions Maintenance Reminder Unit (Z126).

Tachometer

The tachometer displays engine speed in rpm. Voltage pulses are taken from the Alternator (Z106) and are generated when the engine drive belt turns the alternator pulley. The tachometer responds to the frequency of the voltage pulses, which increases proportionally to that of the engine speed.

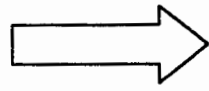
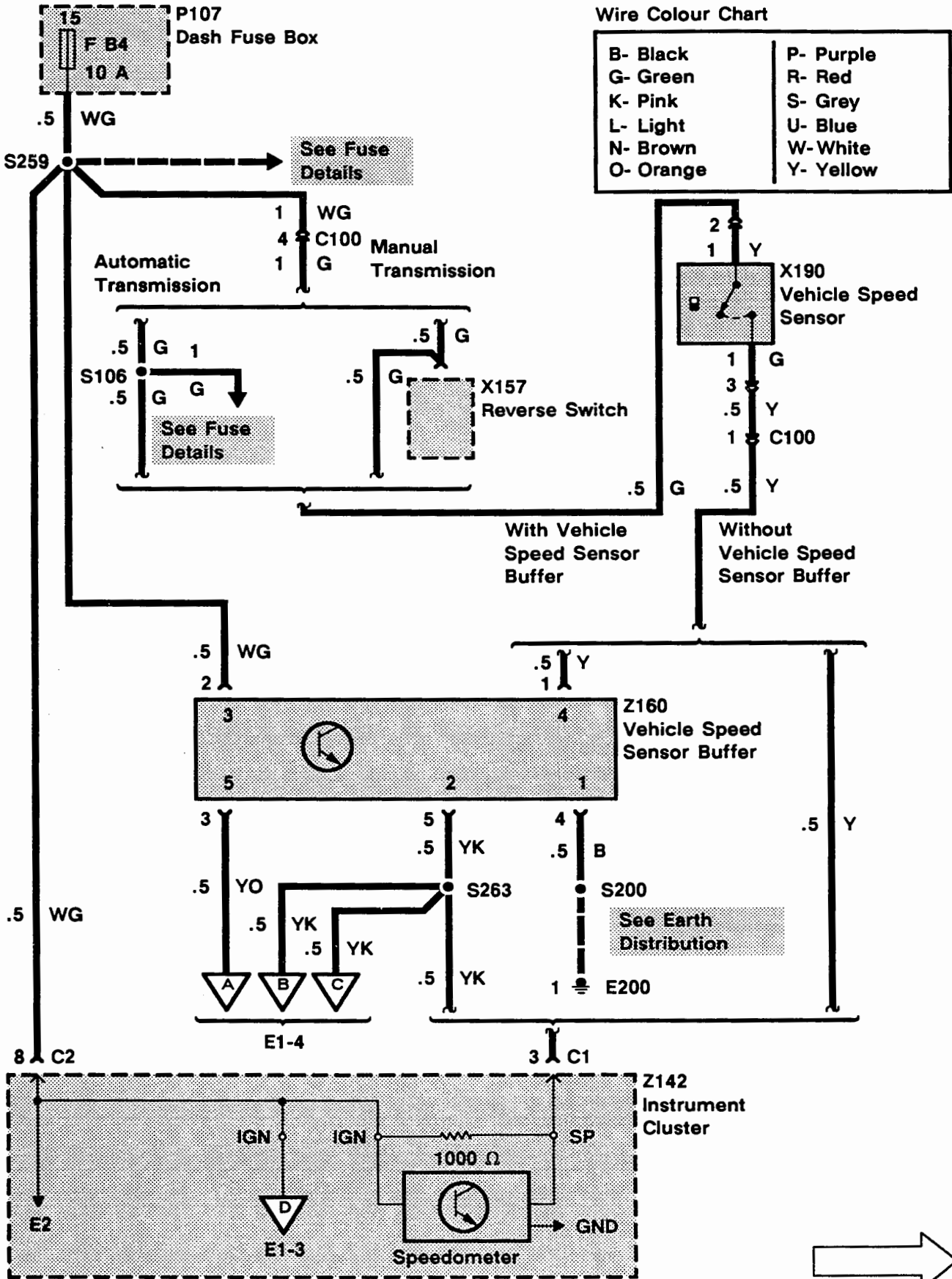

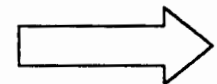
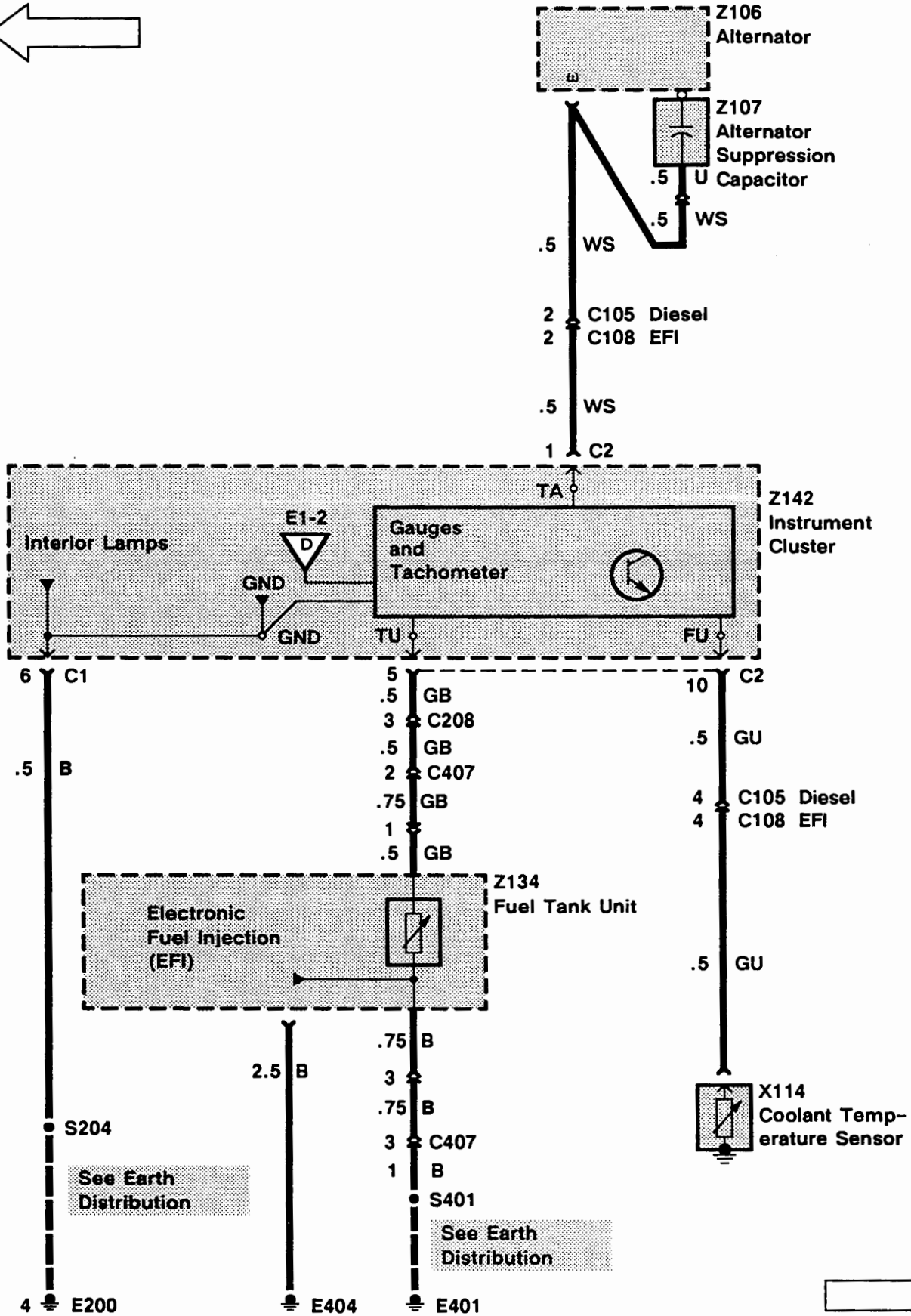
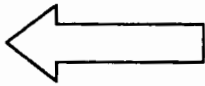

E1 ETM

1992 RANGE ROVER

Wire Colour Chart

B- Black	P- Purple
G- Green	R- Red
K- Pink	S- Grey
L- Light	U- Blue
N- Brown	W- White
O- Orange	Y- Yellow

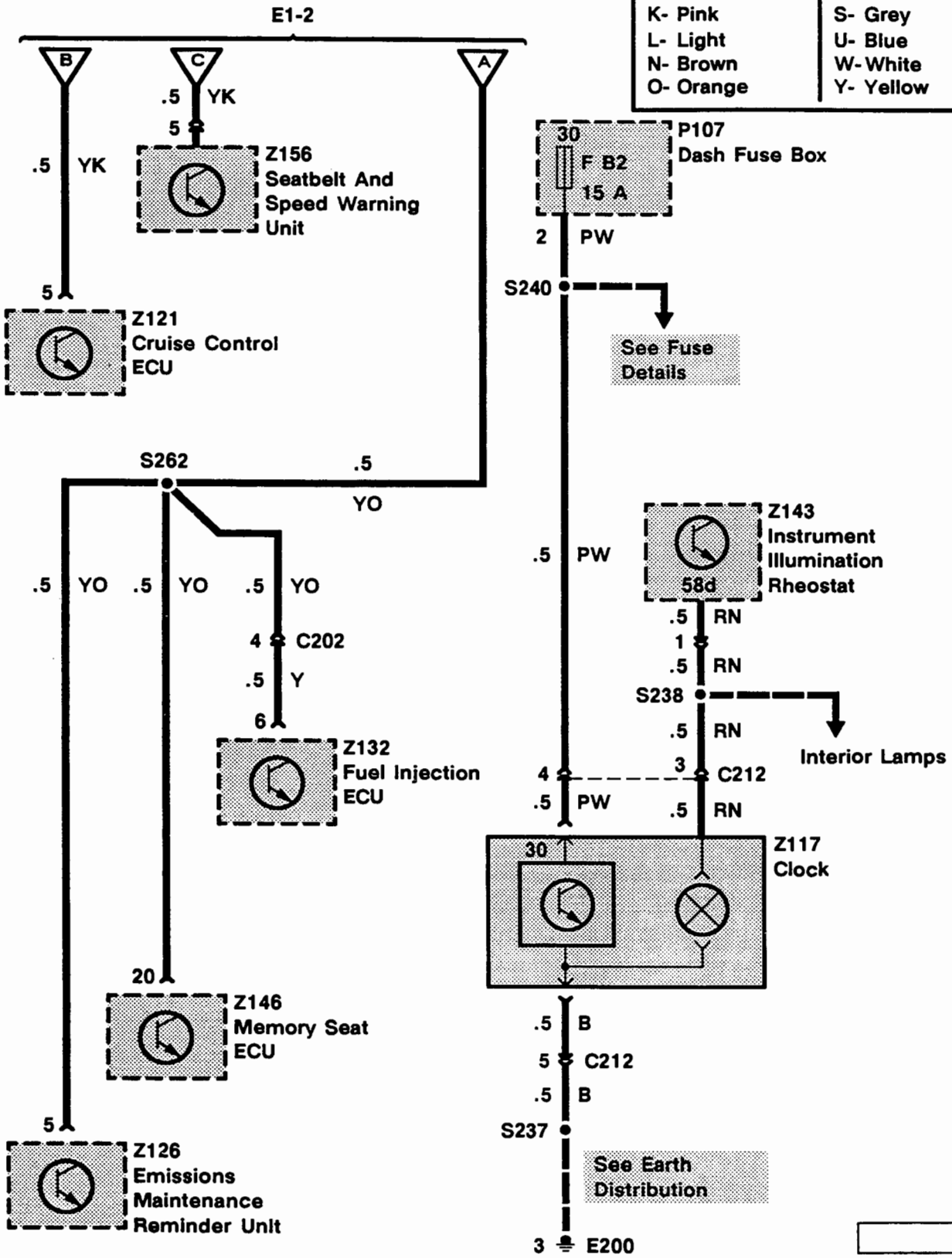

SYSTEM DIAGNOSIS

1. If no instruments operate, do Test A.
2. If the coolant temperature gauge reads hot with coolant cool, do Test B.
3. If the coolant temperature gauge reads cool with coolant hot, do Test B.
4. If the fuel gauge reads empty with fuel in the tank, do Test C.
5. If the fuel gauge reads full when the tank is empty, do Test C.
6. If the speedometer does not operate, do Test D.
7. If the tachometer does not operate, do Test E.

Test A

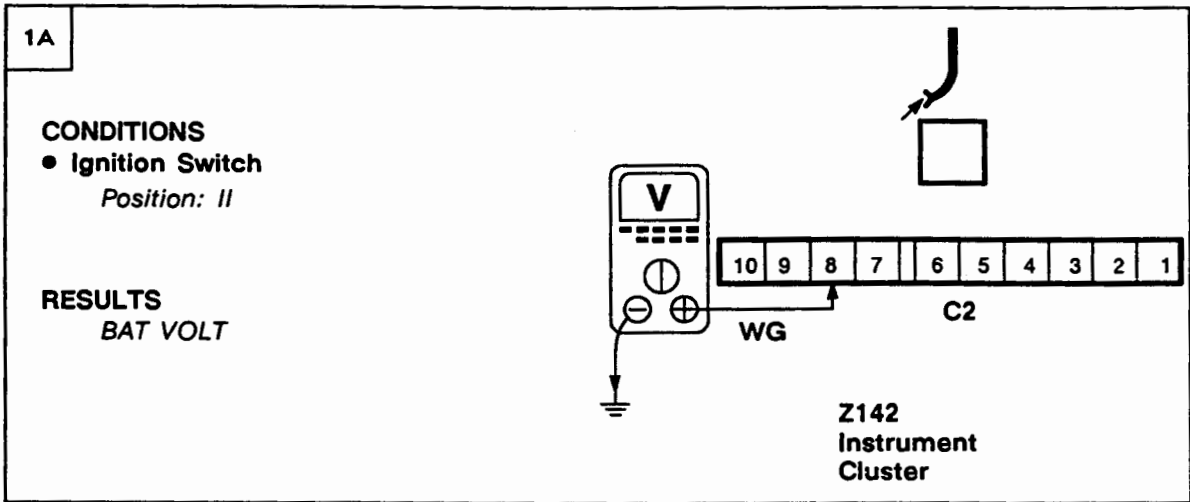

PROBLEM CAUSE

- WG Wire
- F B4 Fuse

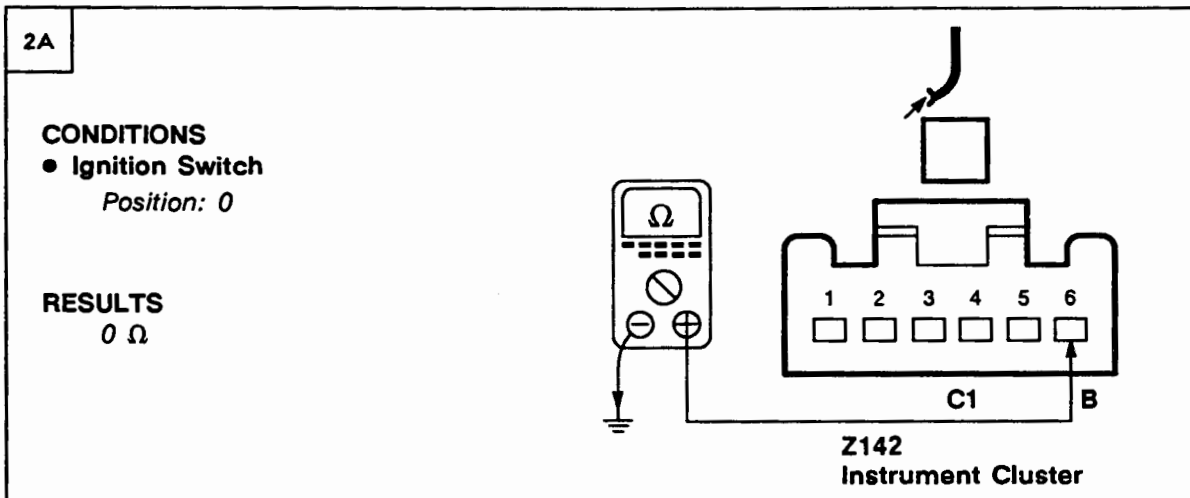

PROBLEM CAUSE

- B Wire



PROBLEM CAUSE

- Instrument Cluster

Test B

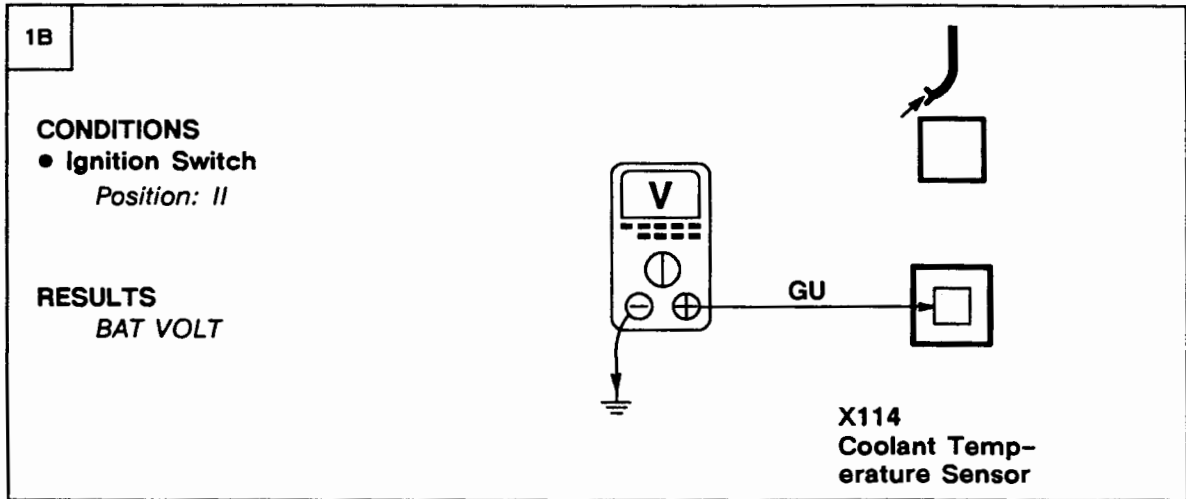

PROBLEM CAUSE

- GU Wire
- Instrument Cluster
- Coolant Temperature Gauge



PROBLEM CAUSE

- Coolant Temperature Sensor

Test C

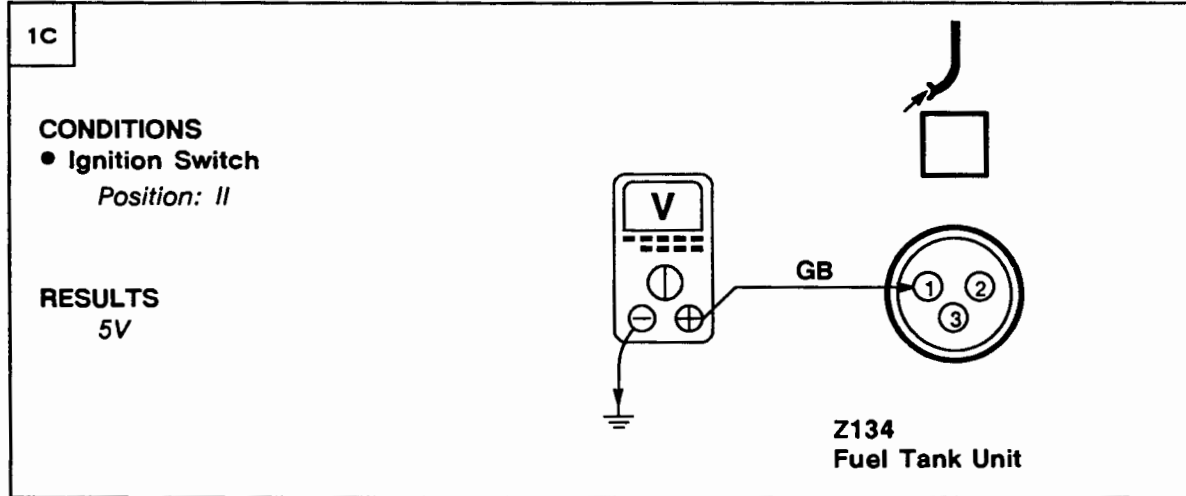

PROBLEM CAUSE

- GB Wire
- Instrument Cluster
- Fuel Gauge

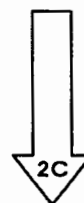

1C

2C

CONDITIONS

- Ignition Switch
Position: II

RESULTS
5V

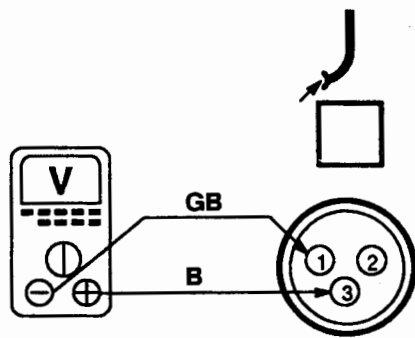

**Z134
Fuel Tank Unit**



PROBLEM CAUSE
- B Wire



PROBLEM CAUSE
- Fuel Tank Unit

Test D

1D

CONDITIONS

- Ignition Switch
Position: II
- Gear Selector
N
- Raise vehicle
- Turn a drive wheel by hand

RESULTS
 0V - BAT VOLT
 (6 times per revolution)

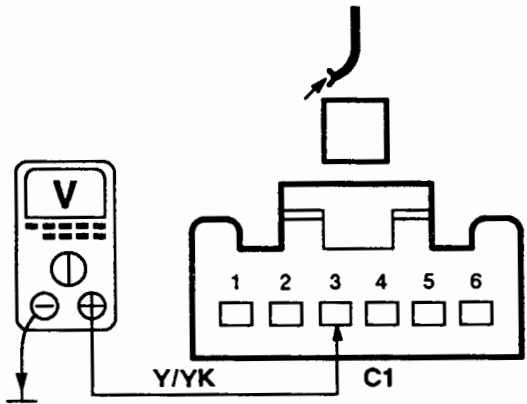

**Z142
Instrument Cluster**



PROBLEM CAUSE



**WITH VEHICLE
SPEED SENSOR
BUFFER**
- Go to Test 2D

**WITHOUT VEHICLE
SPEED SENSOR
BUFFER**
- Y Wire
- G Wire
- Vehicle Speed Sensor



PROBLEM CAUSE
- Instrument Cluster
- Speedometer

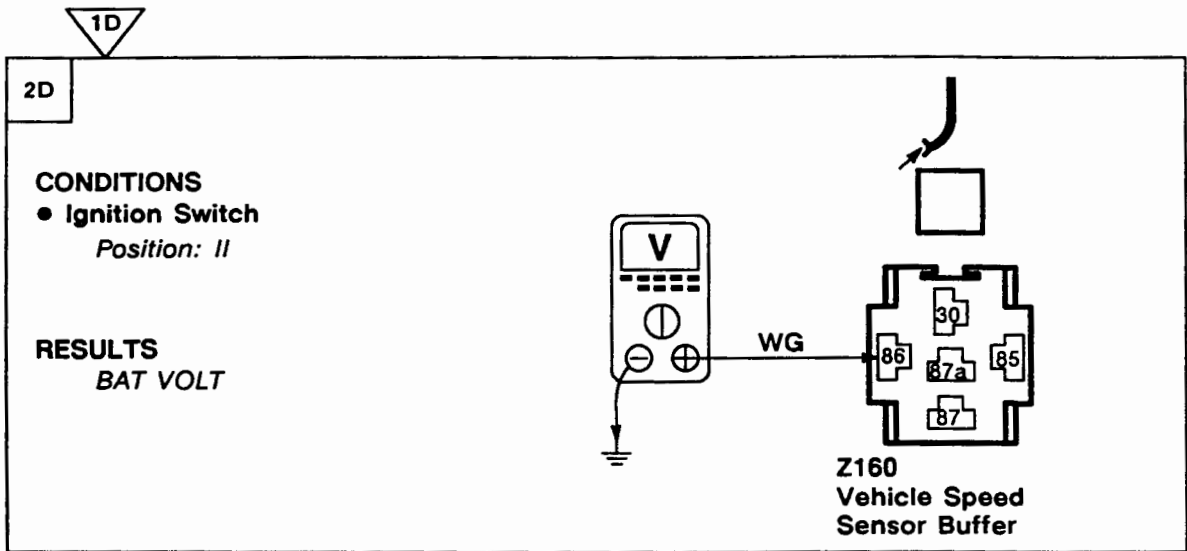

~~OK~~ PROBLEM CAUSE
 - WG Wire
 - F B4 Fuse

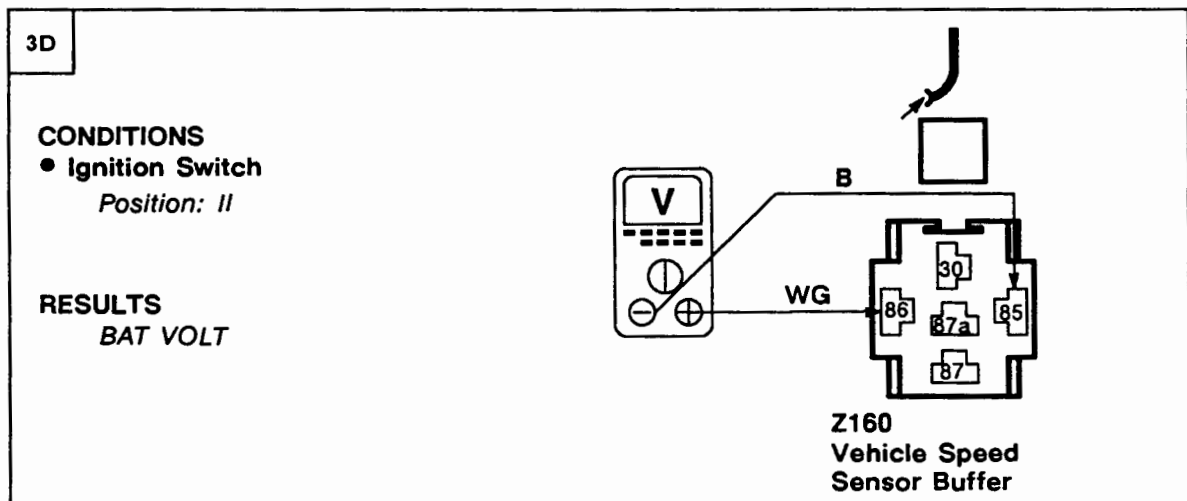
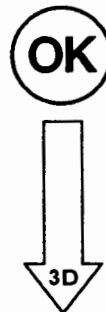

~~OK~~ PROBLEM CAUSE
 - B Wire

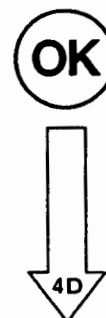

3D

4D

**Z160
Vehicle Speed
Sensor Buffer**

CONDITIONS

- Ignition Switch
Position: II
- Gear Selector
N
- Raise vehicle
- Turn a drive wheel by hand

RESULTS

⏏ 0V - BAT VOLT
(6 times per revolution)



- PROBLEM CAUSE**
- Y Wire
 - WG Wire
 - Vehicle Speed Sensor

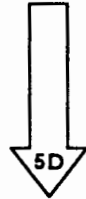

5D

**Z160
Vehicle Speed
Sensor Buffer**

CONDITIONS

- Ignition Switch
Position: II
- Gear Selector
N
- Raise vehicle
- Turn a drive wheel by hand

RESULTS

⏏ 0V - BAT VOLT
(6 times per revolution)



- PROBLEM CAUSE**
- YK wire (short)
 - YO wire (short)
 - Component shorting YK or YO wires (see E1-4)
 - Vehicle Speed Sensor Buffer



- PROBLEM CAUSE**
- YK Wire

Test E

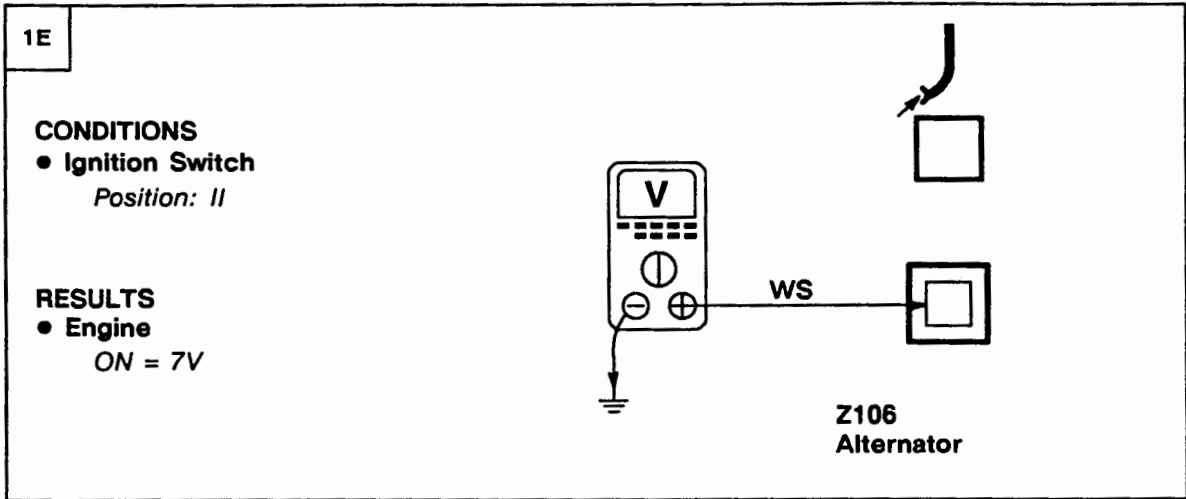

PROBLEM CAUSE
- Alternator



PROBLEM CAUSE
- WS Wire
- Instrument Cluster
- Tachometer

1992 RANGE ROVER

KEY INFORMATION

CIRCUIT DIAGRAMS

- Circuit diagrams are arranged so that current flow is from the top of the diagram (current source) to the bottom of the diagram (earth).
- Only those components that work together in the circuit are shown. If only part of a component is used in the circuit, then only that part of the component is shown.
- Remember:

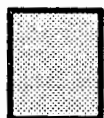

Entire component

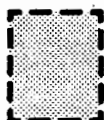

Part of a component

TERMINAL NUMBER

50

DESIGNATION

Battery voltage: Ignition Switch in position III

30

Battery voltage: supplied constantly

15

Battery voltage: Ignition Switch in position II or III

R

Battery voltage: Ignition Switch in positions I, II

31

Earth

See Introduction (i) for additional circuit diagram symbols.

DIAGNOSIS

- If the diagram is accompanied by text:
 - Read the Circuit Operation before proceeding with the electrical diagnosis.
 - Read the Troubleshooting Hints before performing the System Diagnosis.
 - Tests follow the System Diagnosis.
 - When performing the System Diagnosis, be certain that all components disconnected in previous steps are reconnected unless otherwise directed.



Component is disconnected.
Backprobe harness connector



Component is connected.
Backprobe harness connector



Component is disconnected.
Probe component



Component is disconnected.
Probe harness connector



Probe in-line connector

CIRCUIT OPERATION**Charge Warning Light**

The charge warning light receives battery voltage with the Ignition Switch (X134) in position II. This warning light is earthed by the Alternator (Z106) if the Alternator is not producing normal power output or the Alternator stops turning.

ABS Warning Light

The ABS warning light receives battery voltage with the Ignition Switch (X134) in position II. It is earthed by the Anti-Lock Brake System ECU (Z108) or the ABS Warning Relay (K103) in the event of an ABS problem.

Brake Warning Light

The brake warning light receives battery voltage with the Ignition Switch (X134) in position II. It is earthed by the Brake Fluid Level Switch (X111) when the brake fluid level is low. It may also be earthed through the Brake Fluid Level Switch (X111) and the brake fluid level switch diode when the HandBrake Switch (X191) is closed. The warning light is also earthed by the Anti-Lock Brake System ECU (Z108) or by the ABS Pressure Switch Unit (Z104) in the event of an ABS system problem. When the Ignition Switch (X134) is in position III, battery voltage is applied to the Brake Warning Light Check Relay (K106). The relay is energized, applying earth to the brake warning light as a bulb check.

Low Engine Oil Level/Pressure Warning Light

The low engine oil level/pressure warning light warning light receives battery voltage with the Ignition Switch (X134) in position II. If the engine oil pressure is very low, the Oil Pressure Switch (X149) will apply earth to the warning light. The oil level detection system consist of an Engine Oil Level Sensor (X148) and Engine Oil Level Monitor Unit (Z146). When the Ignition Switch (X134) is first put in position II, battery voltage is applied to the Engine Oil Level Monitor Unit (Z127). The Engine Oil Level Monitor Unit (Z127) then sends a voltage signal to the Engine Oil Level Sensor (X148) and looks for a return of that voltage signal. If the signal

is not returned, the Engine Oil Level Monitor Unit (Z127) flashes the low engine oil level/pressure warning light for 10 to 20 seconds by applying a pulsing earth signal to the warning light. If the ignition is switched to position II after being at position 0 for less than 15 to 30 seconds, the Engine Oil Level Monitor Unit (Z127) will ignore the Engine Oil Level Sensor (X148) and not flash the warning light even if the oil level is low.

Transmission/Transfer Box Oil Temperature Warning Light

The transmission/transfer box oil temperature warning light is earthed by the Automatic Transmission Oil Temperature Switch (X108) when the temperature of the transmission fluid exceeds 130°C (266°F). The warning light is also earthed by the Transfer Box Oil Temperature Switch (X174) when the temperature of the transfer box fluid exceeds 145°C (266°F).

Check Engine Warning Light

The check engine warning light is earthed by the Fuel Injection ECU (Z132) when a fault code is set.

Brake Pad Wear Warning Light

When the Right Front or Right Rear Inboard Brake Pad (B129, B135) is in need of replacement, the brake pad wear warning light is earthed through the Right Front or Right Rear Inboard Brake Pad (B129, B135). The brake pad wear warning light is also earthed by the Handbrake Switch (X191) via the brake pad warning check diode as a bulb check.

Engine Glow Plug Timer Warning Light (Diesel)

The diesel engine glow plug timer warning light is earthed by the Glow Plug Timer Unit (Z135) to indicate that the glow plugs are not yet warm enough to attempt engine starting.

Low Screen Wash Fluid Warning Light

The low screen wash fluid warning light is earthed by the Screen Wash Fluid Level Switch (X165) when the fluid reservoir requires filling.

Low Coolant Level Warning Light

The Instrument Cluster (Z142) receives battery voltage through the Low Coolant Level Switch (X144) with the Ignition Switch (X134) in Position II and the engine coolant level OK. If the engine coolant level is low, the Low Coolant Level Switch (X144) opens, removing voltage from the Instrument Cluster (Z142). The Instrument Cluster then lights the low coolant level warning light.

THIS PAGE HAS BEEN INTENTIONALLY LEFT BLANK

Wire Colour Chart

B- Black	P- Purple
G- Green	R- Red
K- Pink	S- Grey
L- Light	U- Blue
N- Brown	W- White
O- Orange	Y- Yellow

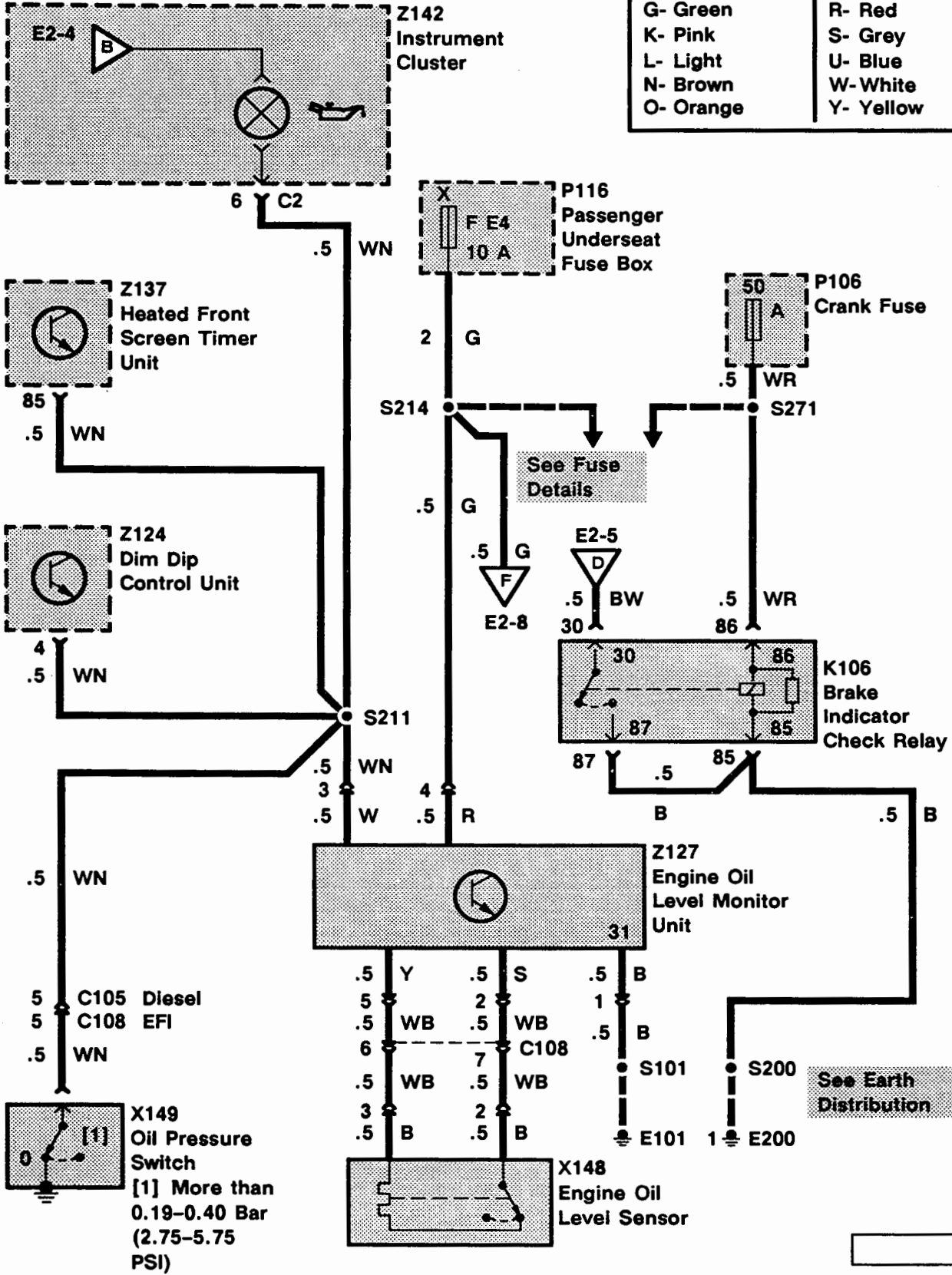

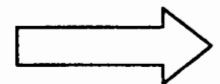
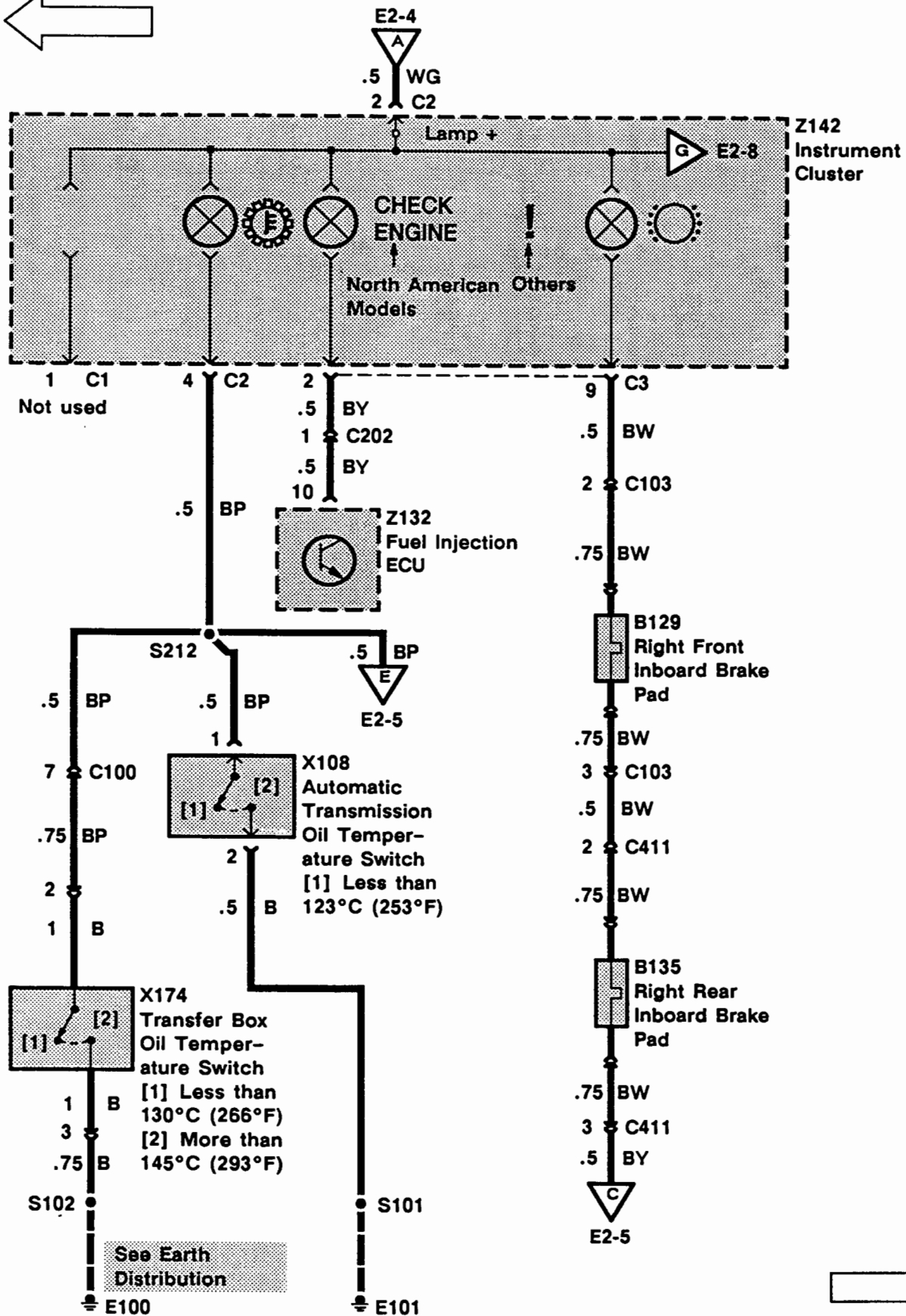
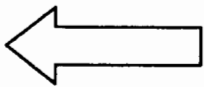

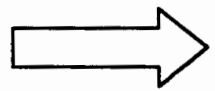
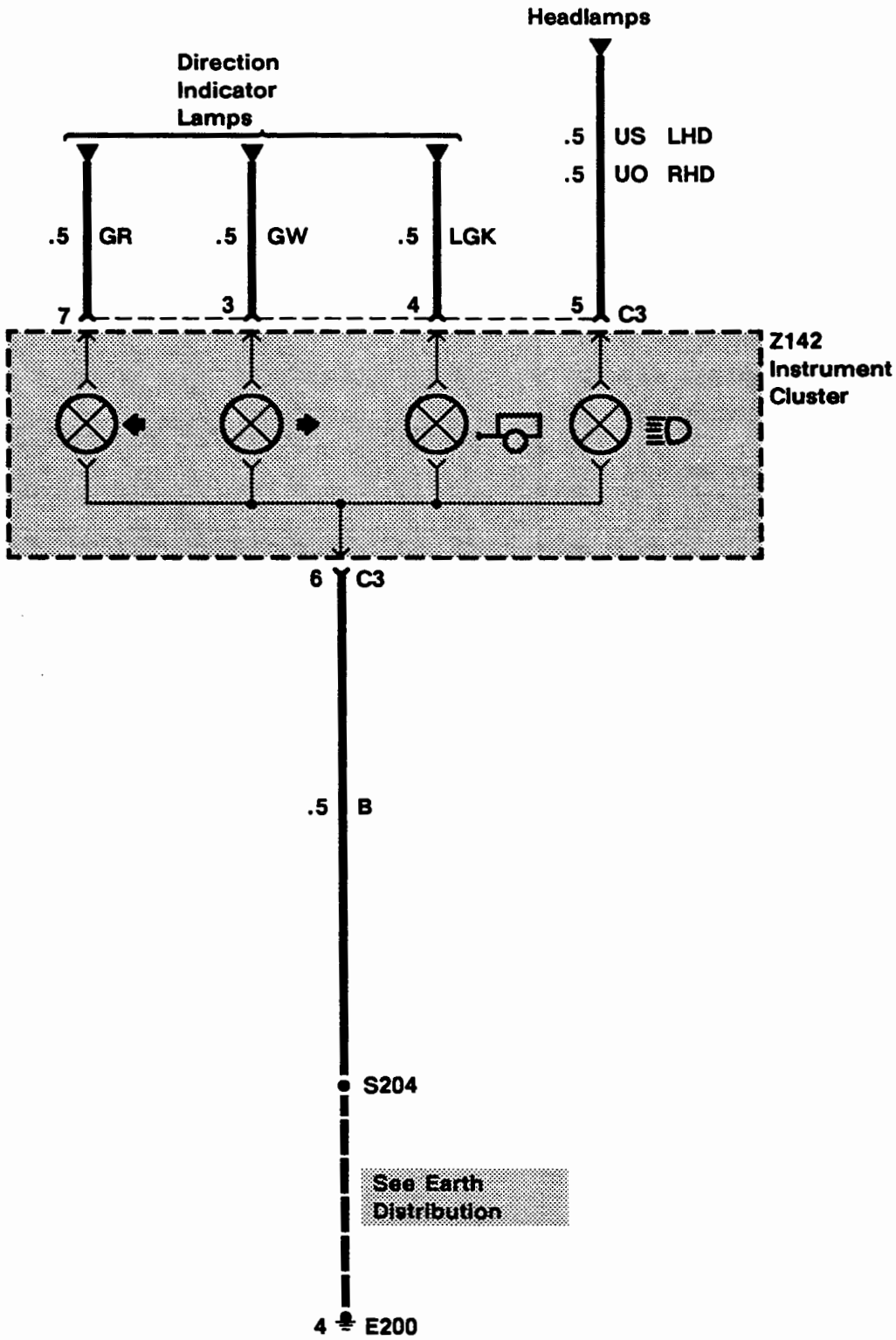
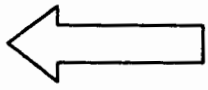

TROUBLESHOOTING HINTS

If more than one warning light is out, check power and earth wires common to all affected warning lights.

SYSTEM DIAGNOSIS

1. If the charge warning light does not operate, go to Section B1 or B2.
2. If the ABS warning light does not operate, go to Section D1.
3. If the low engine oil level/pressure warning light remains illuminated with the oil pressure OK, do Test A.
4. If the low engine oil level/pressure warning light flashes with the oil level OK, do Test B.
5. If the low engine oil level/pressure warning light does not flash with the oil level low, do Test C.
6. If the brake warning light does not light with the Ignition Switch (X134) in position III, do Test D.
7. If the check engine warning light does not operate properly, go to Section A1.
8. If a warning light exhibits any symptom not mentioned above, check the associated bulb, wires, switches and components.

Test A

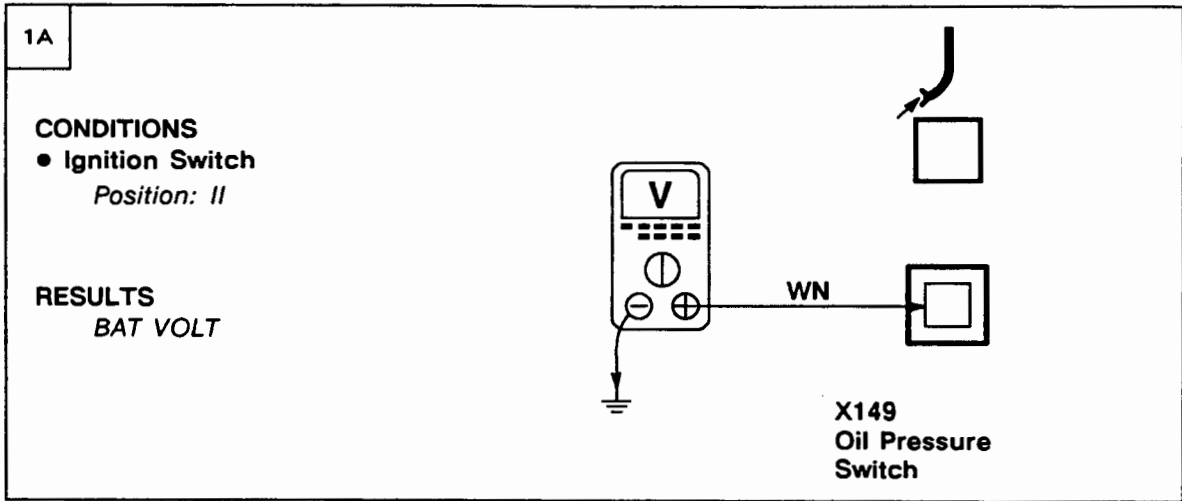

- PROBLEM CAUSE**
- WN Wire
 - Engine Oil Level Monitor Unit
 - Dim Dip Control Unit
 - Heated Front Screen Timer Unit



- PROBLEM CAUSE**
- Oil Pressure Switch

Test B

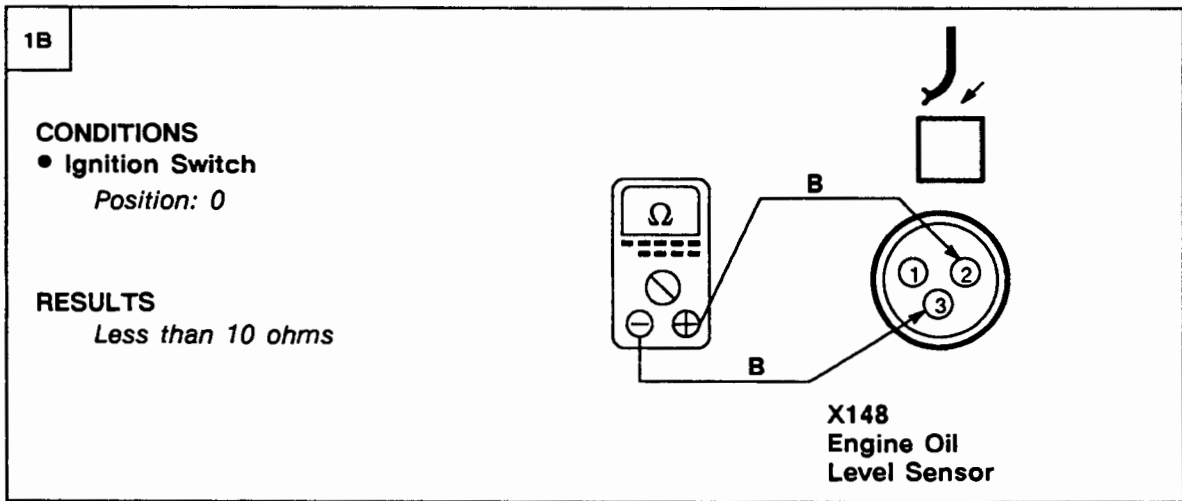

- PROBLEM CAUSE**
- Engine Oil Level Sensor



- PROBLEM CAUSE**
- WB Wire
 - Engine Oil Level Monitor Unit

Test C

1C

CONDITIONS

- Ignition Switch
Position: II

RESULTS
= 2V

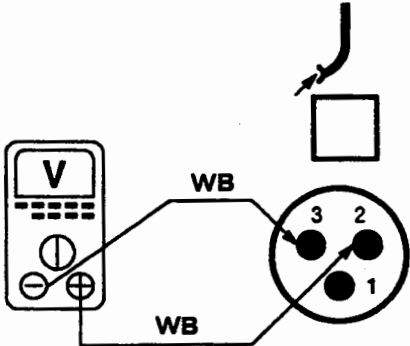

X148
Engine Oil
Level Sensor

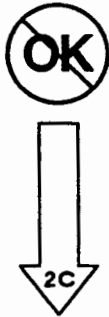

OK PROBLEM CAUSE
- Engine Oil Level Sensor

2C

CONDITIONS

- Ignition Switch
Position: II

RESULTS
BAT VOLT

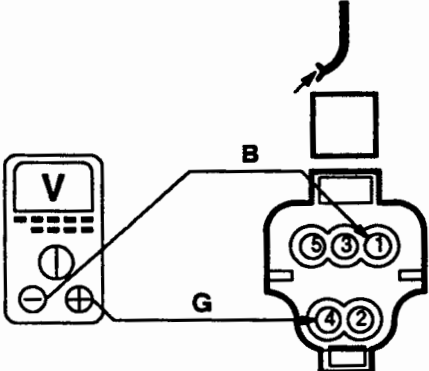

Z127
Engine Oil
Level Monitor Unit

OK PROBLEM CAUSE
- B Wire
- G Wire
- F E4 Fuse

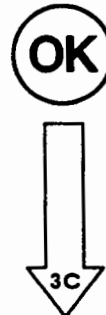

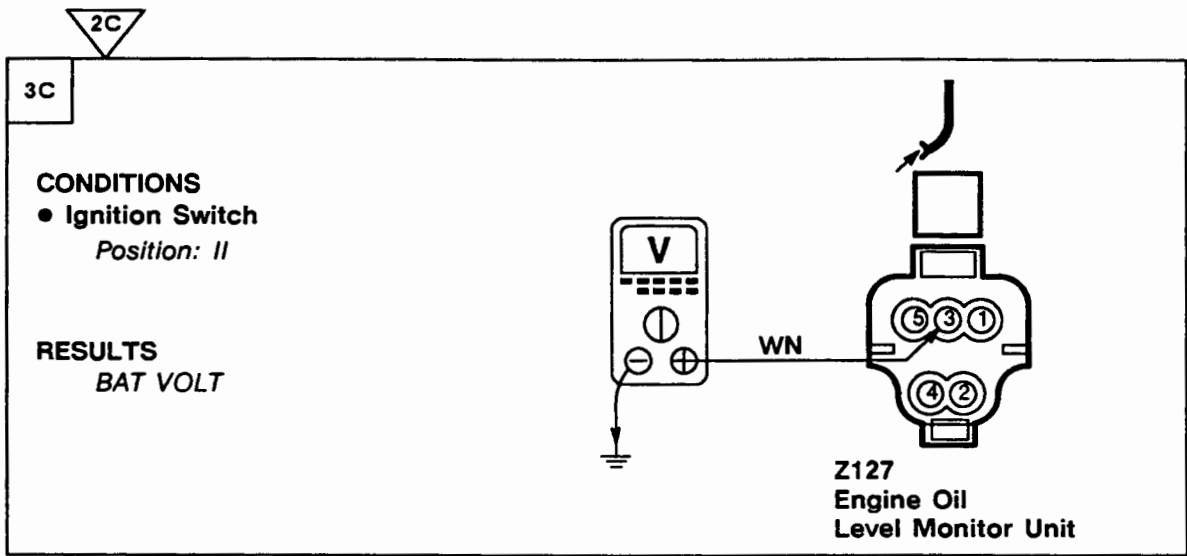

OK PROBLEM CAUSE

- WN Wire
- Bulb

OK PROBLEM CAUSE

- Engine Oil Level Monitor Unit

Test D

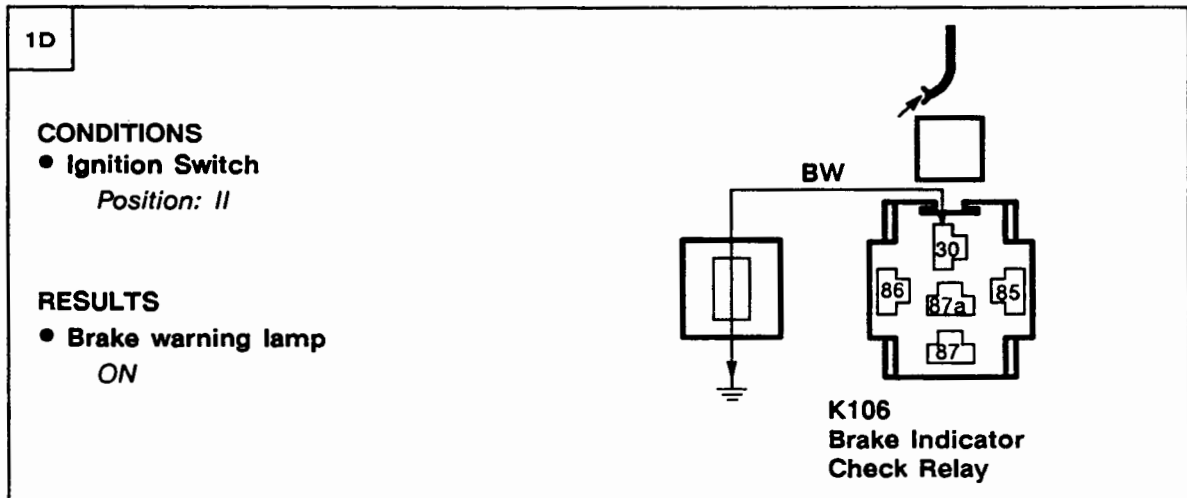

OK PROBLEM CAUSE

- BW Wire
- Diode
- BK Wire
- BG Wire
- Brake Fluid Level Switch

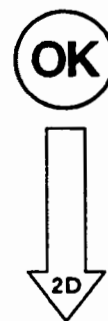

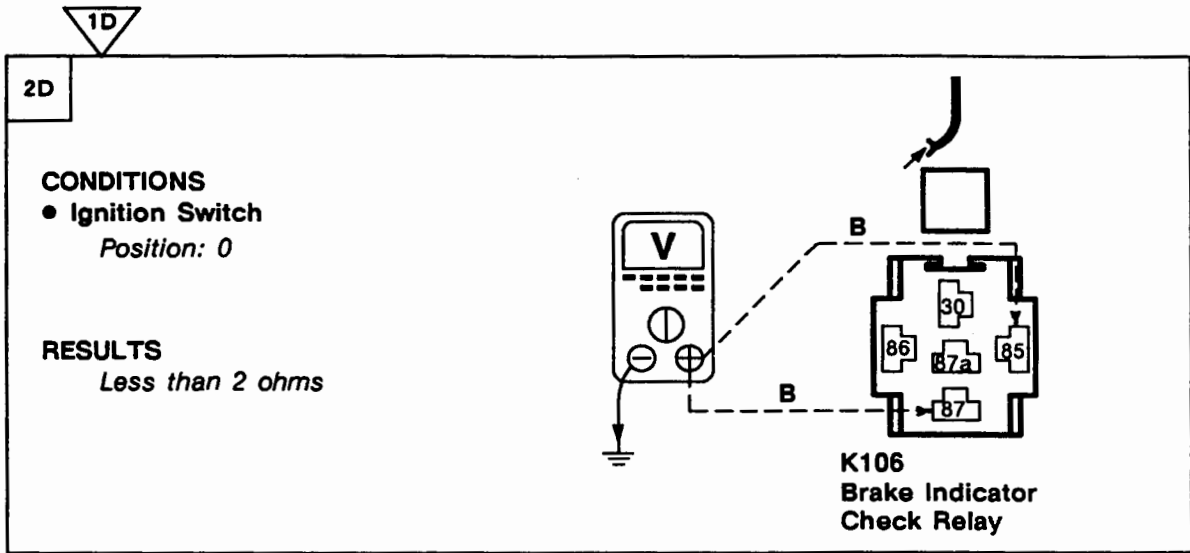

~~OK~~ **PROBLEM CAUSE**
- B Wire

OK

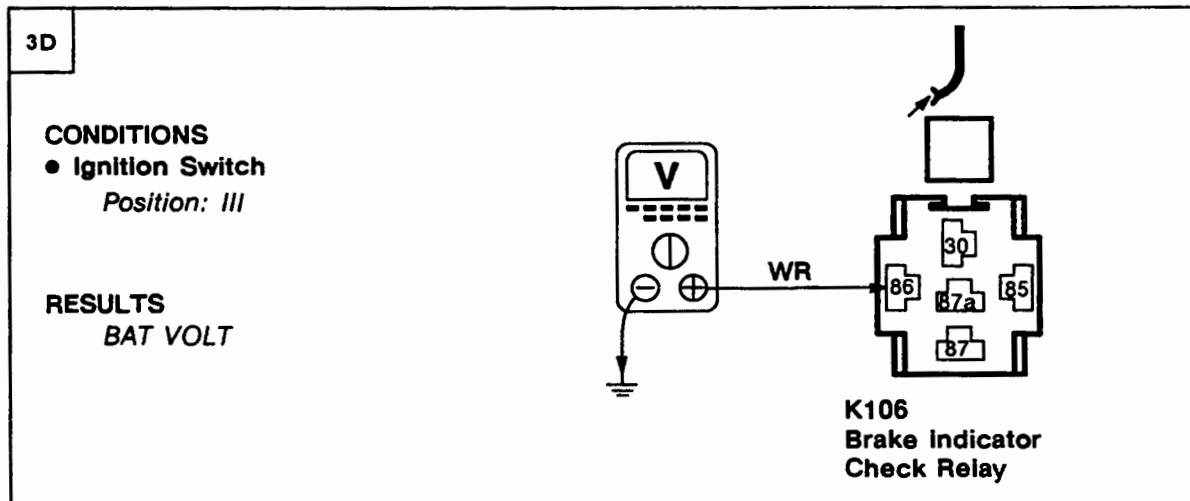

~~OK~~ **PROBLEM CAUSE**
- WR Wire
- Crank Fuse

OK **PROBLEM CAUSE**
- Brake Indicator Check Relay

CIRCUIT OPERATION**Warning Lamps Check Unit (Z161)**

The Warning Lamps Check Unit (Z161) applies earth and/or voltage to the following warning lights momentarily as a bulb check when the Ignition Switch (X134) is in position II: ABS, brake pad wear, check engine, high beam, low coolant level, low screen wash fluid, seat belt, transmission/transfer box oil temperature and brake, turn and trailer turn.

Audible Warning Unit (Z109)

The Audible Warning Unit (Z109) receives power at all times. It also receives battery voltage with the Ignition Switch (X134) in position II. It receives an earth signal from the Driver Seat Buckle Switch (X120) with the seat belt unbuckled. It receives an earth signal from the Driver Door Switch (X118) with the door open. It receives a voltage signal from the Ignition Key Switch (X177) with the key in the Ignition Switch (X134). It receives an earth signal from the Transfer Box Position Switch (X175) with the transfer box in positions H or N and a voltage signal via the transfer box resistor with the transfer box in position N. The Audible Warning Unit (Z109) sounds a warning tone if the key is in the Ignition Switch (X134) with the driver's door open, or with the transfer box in neutral or with the driver's seat belt unbuckled.

Seatbelt And Speed Warning Unit (Z156)

The Seatbelt And Speed Warning Unit (Z156) receives a pulsing voltage from the Vehicle Speed Sensor Buffer (Z160). The driver's seat buckle provides an earth signal to this unit when the driver's seat belt is unbuckled.

Charge Warning Light

The charge warning light receives battery voltage with the Ignition Switch (X134) in position II. It is earthed by the Alternator (Z106) if the Alternator is not producing normal power output or the Alternator stops turning.

ABS Warning Light

The ABS warning light receives battery voltage with the Ignition Switch (X134) in position II.

This warning light is earthed by the Anti-Lock Brake System ECU (Z108) or the ABS Warning Relay (K103) in the event of an ABS problem. The Warning Lamps Check Unit (Z161) applies earth to the warning light momentarily as a bulb check when the Ignition Switch (X134) is moved to position II.

Brake Warning Light

The brake warning light receives battery voltage with the Ignition Switch (X134) in position II. It is earthed by the Brake Fluid Level Switch (X111) when the brake fluid level is low. It may also be earthed through the Brake Fluid Level Switch (X111) and the brake fluid level switch diode when the Handbrake Switch (X191) is closed. The warning light is also earthed by the Anti-Lock Brake System ECU (Z108) or by the ABS Pressure Switch Unit (Z104) in the event of an ABS system problem. When the Ignition Switch (X134) is in position III, battery voltage is applied to the Brake Warning Light Check Relay (K106). The relay is energized, applying earth to the brake warning light as a bulb check.

Low Engine Oil Level/Pressure Warning Light

The low engine oil level/pressure warning light receives battery voltage with the Ignition Switch (X134) in position II. If the engine oil pressure is very low, the Oil Pressure Switch (X149) will apply earth to the warning light. The oil level detection system consist of an Engine Oil Level Sensor (X148) and Engine Oil Level Monitor Unit (Z127). When the Ignition Switch (X134) is initially put in position II, battery voltage is applied to the monitor unit. The monitor unit then sends a voltage signal to the Engine Oil Level Sensor (X148) and looks for a return of that voltage signal. If the signal is not returned, the Engine Oil Level Monitor Unit (Z127) flashes the low engine oil level/pressure warning light for 10 to 20 seconds by applying a pulsing earth signal to the warning light. If the ignition is switched to position II after being at position 0 for less than 15 to 30 seconds, the Engine Oil Level Monitor Unit (Z127) will ignore the Engine Oil Level Sensor (X148) and not flash the warning light even if the oil level is low.

Transmission/Transfer Box Oil Temperature Warning Light

The transmission/transfer box oil temperature warning light is earthed by the Automatic Transmission Oil Temperature Switch (X108) when the temperature of the transmission fluid exceeds 130°C (266°F). The warning light is also earthed by the Transfer Box Oil Temperature Switch (X174) when the temperature of the transfer box fluid exceeds 145°C (266°F). The Warning Lamps Check Unit (Z161) applies earth to the warning light momentarily as a bulb check when the Ignition Switch (X134) is moved to position II.

Check Engine Warning Light

The check engine warning light is earthed by the Fuel Injection ECU (Z132) when a fault code is set. The Warning Lamps Check Unit (Z161) applies earth to the warning light momentarily as a bulb check when the Ignition Switch (X134) is moved to position II.

Brake Pad Wear Warning Light

When the Right Front or Right Rear Inboard Brake Pad (B129, B135) is in need of replacement, the Brake Pad Wear Warning Light is earthed through the Right Front or Right Rear Inboard Brake Pad (B129, B135). The Warning Lamps Check Unit (Z161) applies earth to the warning light momentarily as a bulb check when the Ignition Switch (X134) is moved to position II.

Engine Glow Plug Timer Warning Light (Diesel)

The diesel engine glow plug timer warning light is earthed by the Glow Plug Timer Unit (Z135) to indicate that the glow plugs are not yet warm enough to attempt engine starting.

Low Screen Wash Fluid Warning Light

The low screen wash fluid warning light is earthed by the Screen Wash Fluid Level Switch (X165) when the fluid reservoir requires filling. The Warning Lamps Check Unit (Z161) applies earth to the indicator momentarily as a bulb check when the Ignition Switch (X134) is moved to position II.

Service Engine Warning Light

The service engine warning light is controlled by the Emissions Maintenance Reminder Unit (Z126) and illuminates to indicate to the driver that it is time to check the vehicle's emissions system. The reminder unit receives battery power at all times. When the ignition is switched to position II, the reminder unit momentarily grounds the service engine warning light as a bulb check. While the vehicle is in motion, the reminder unit receives a vehicle speed signal in the form of a pulsing battery voltage. The reminder unit uses this signal to record distance travelled. When a specific distance is reached, the reminder unit earths the service engine warning light.

Low Coolant Level Warning Light

The Instrument Cluster (Z142) receives battery voltage through the Low Coolant Level Switch (X144) with the Ignition Switch (X134) in position II and the engine coolant level OK. If the engine coolant level is low, the Low Coolant Level Switch (X144) opens, removing voltage from the Instrument Cluster. The Instrument Cluster then lights the low coolant level warning light. The Warning Lamps Check Unit (Z161) applies earth to the warning light momentarily as a bulb check when the Ignition Switch (X134) is moved to position II.

THIS PAGE HAS BEEN INTENTIONALLY LEFT BLANK

THIS PAGE HAS BEEN INTENTIONALLY LEFT BLANK

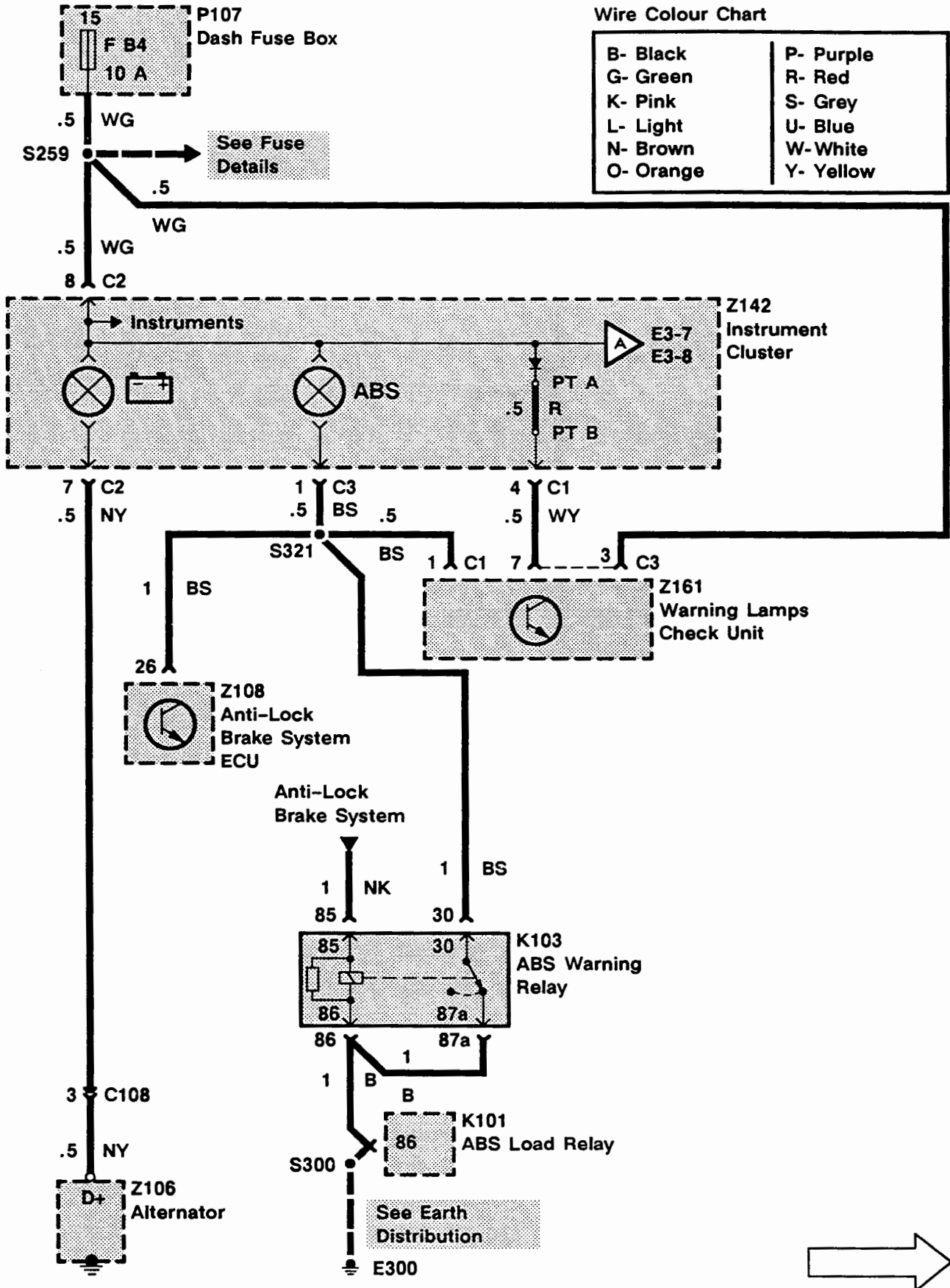

Wire Colour Chart

B- Black	P- Purple
G- Green	R- Red
K- Pink	S- Grey
L- Light	U- Blue
N- Brown	W- White
O- Orange	Y- Yellow

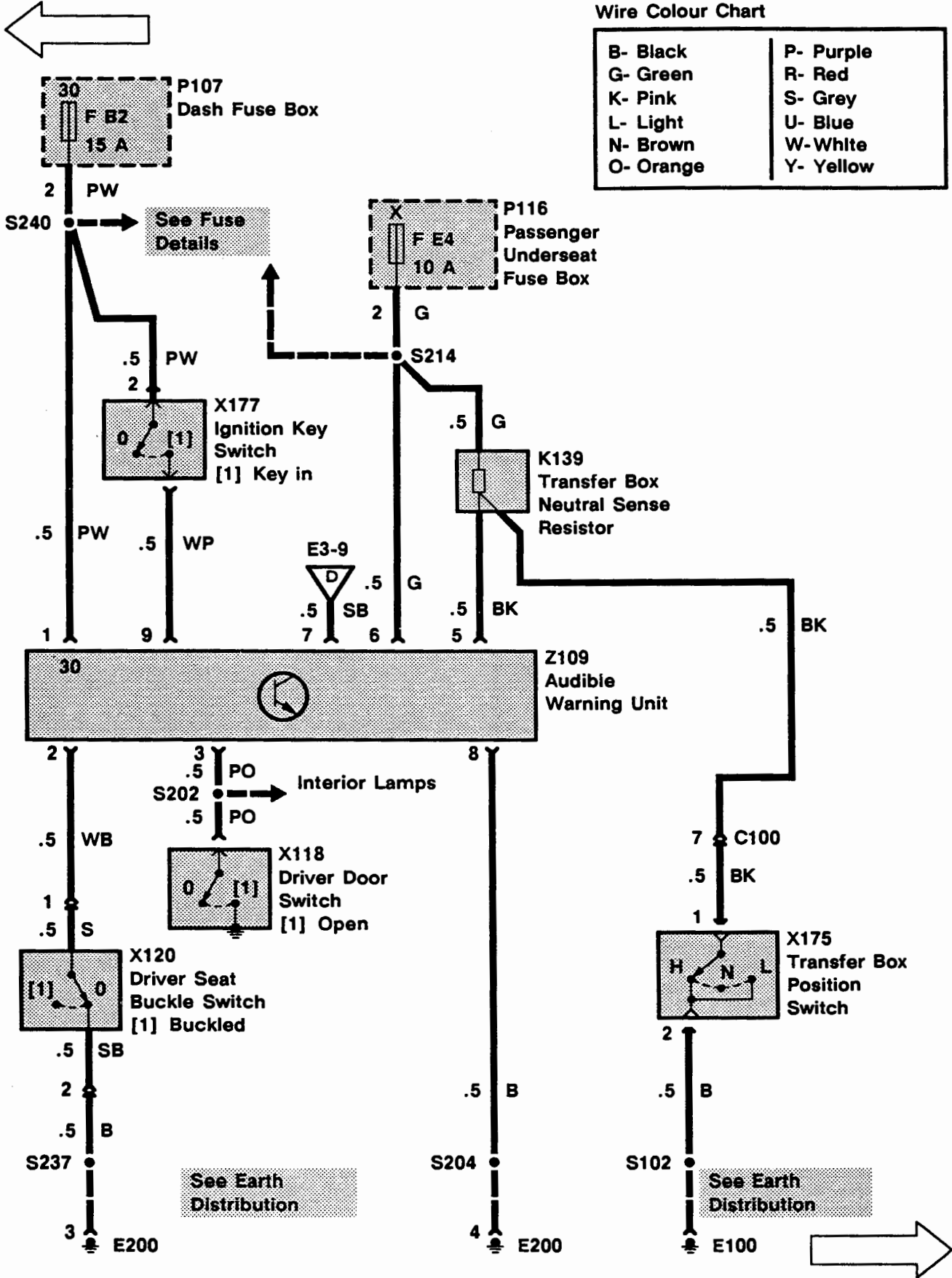

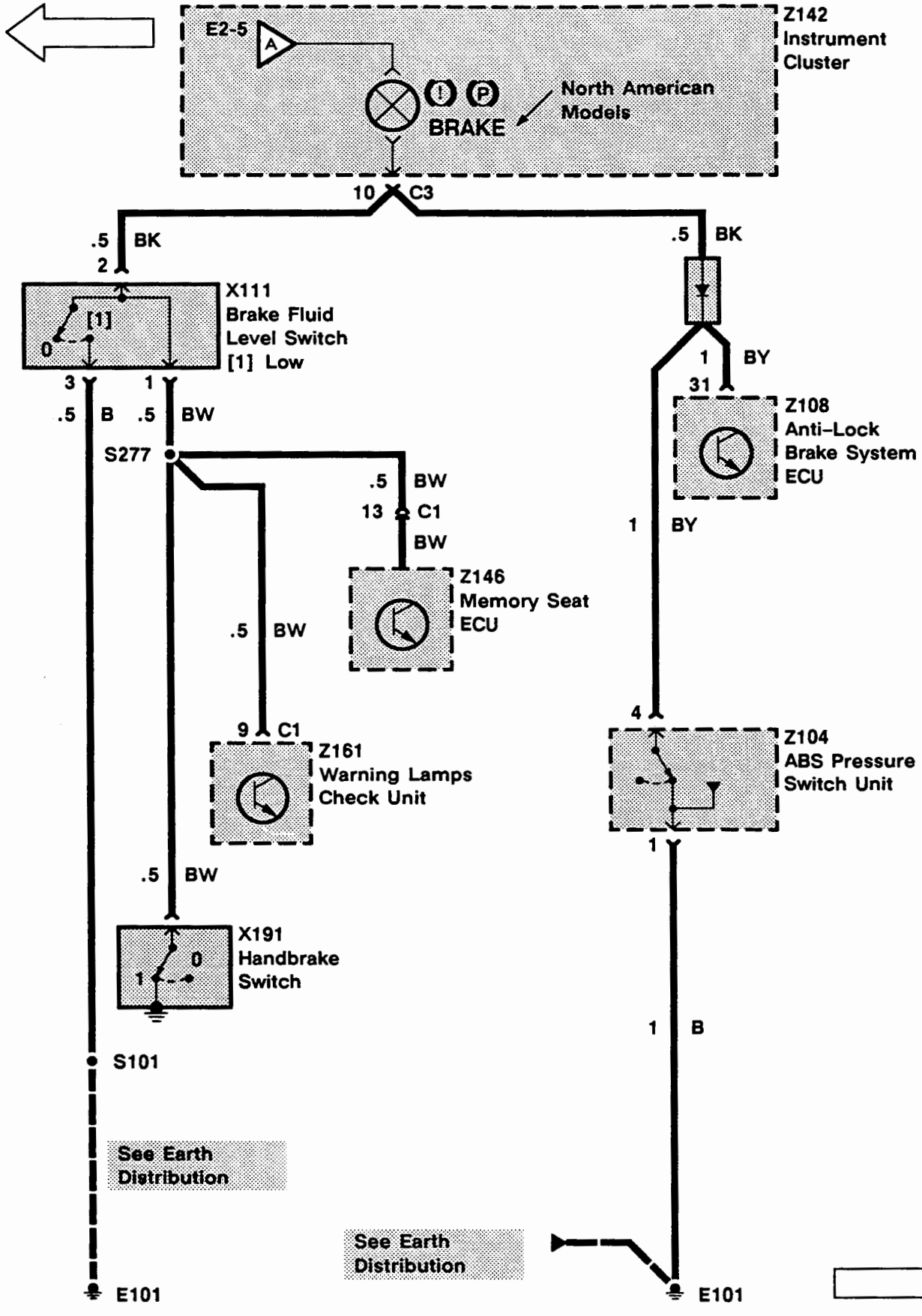

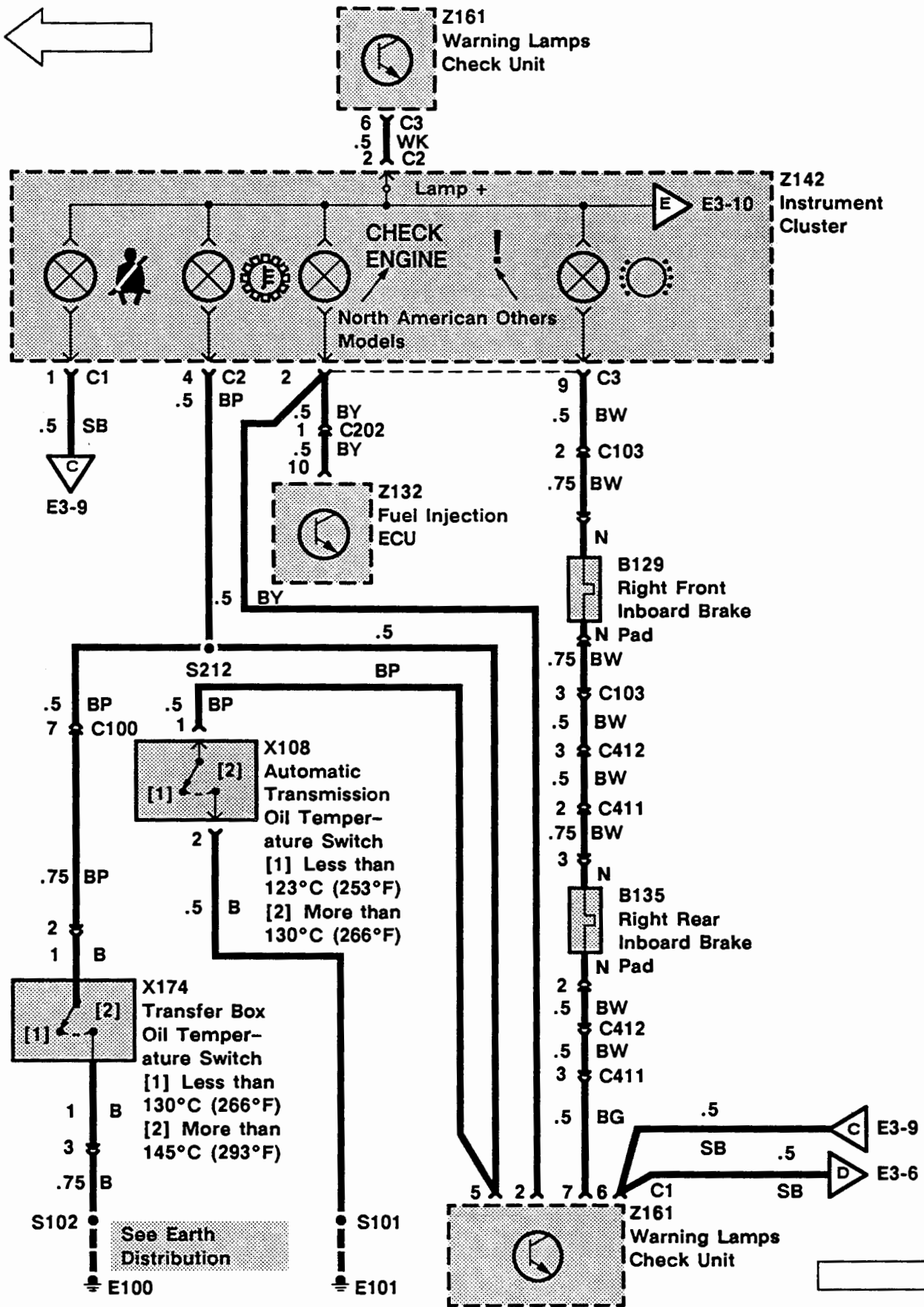

Wire Colour Chart

B- Black	P- Purple
G- Green	R- Red
K- Pink	S- Grey
L- Light	U- Blue
N- Brown	W- White
O- Orange	Y- Yellow

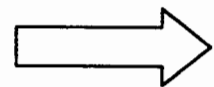
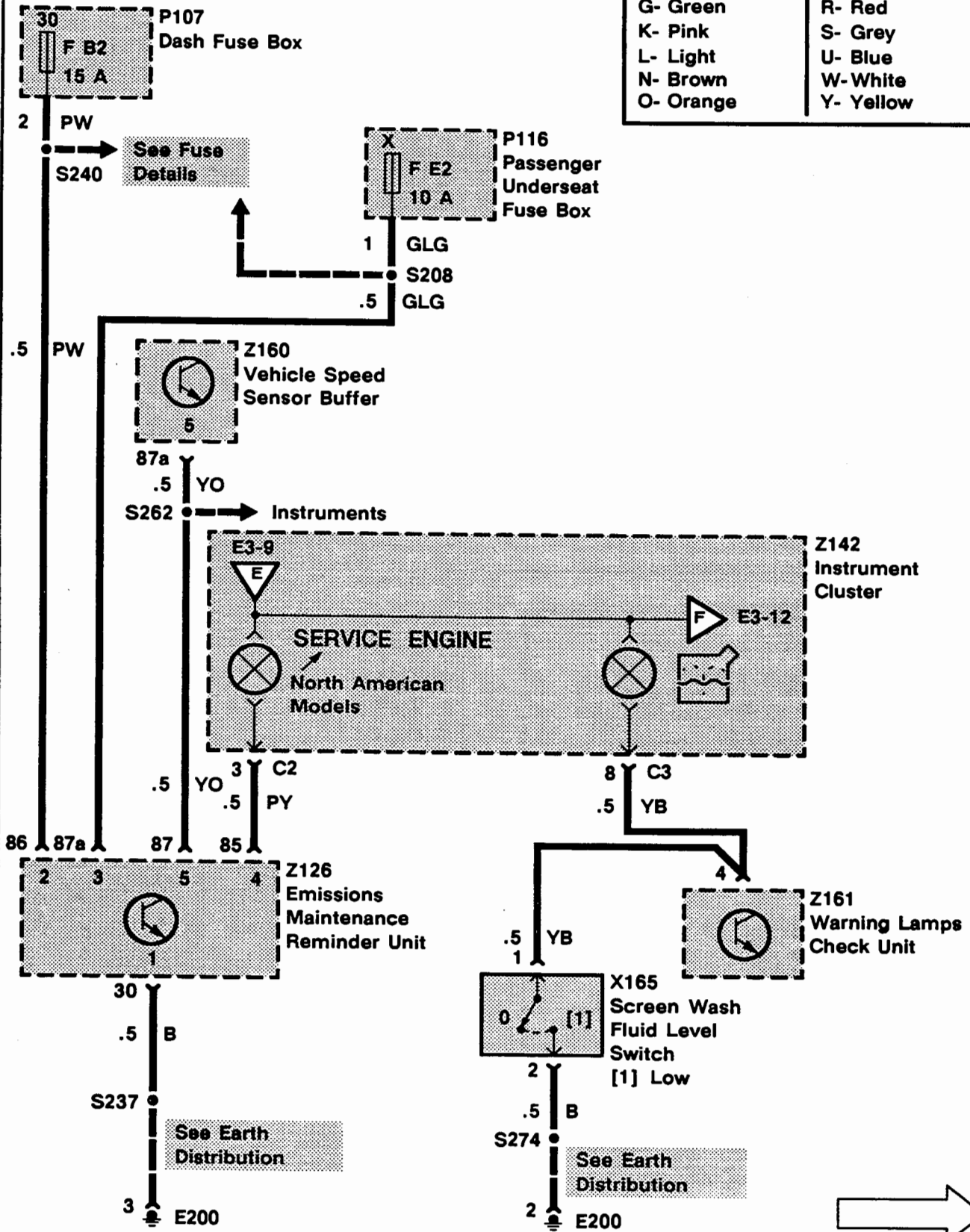

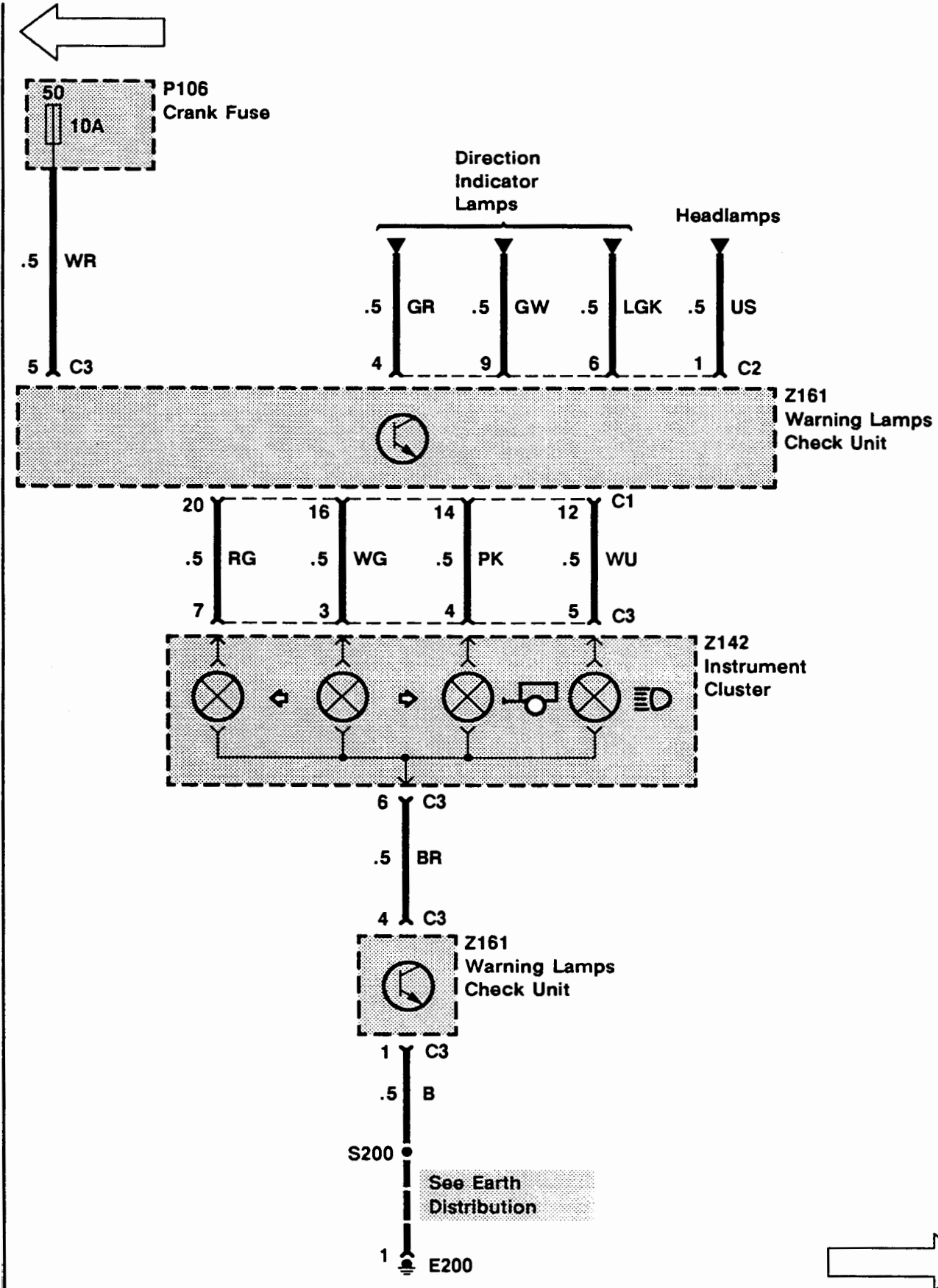

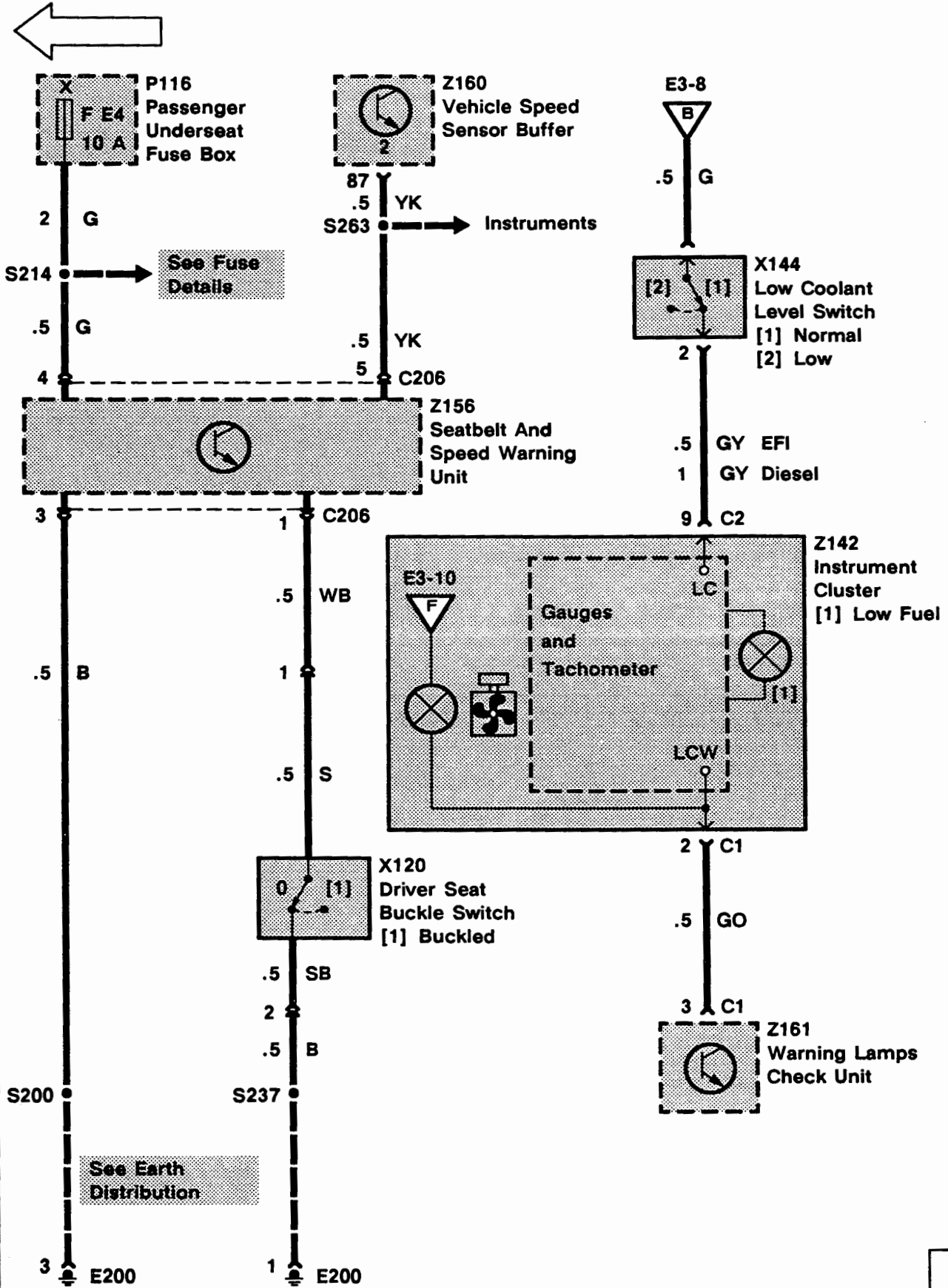

TROUBLESHOOTING HINTS

1. If more than one warning light fails, check power and earth wires common to all affected warning lights.
2. If all warning lights bulbs checked by the Warning Lamps Check Unit (Z161) do not light with the Ignition Switch (X134) in position II, check the B wire and WG wire at the Warning Lamps Check Unit. If all are OK, check the Warning Lamps Check Unit.
3. If a single warning light that is earthed by the Warning Lamps Check Unit (Z161) during a bulb check does not light with the Ignition Switch (X134) in position II, check the bulb, wires and components common to the affected warning light control circuit. If everything is OK, check the Warning Lamps Check Unit.
4. If none of the audible warning tones operate, check the PW and B wires at the Audible Warning Unit (Z109). If all are OK, check the Audible Warning Unit.
5. If the seat belt tone is not heard, check the WB wire, B wire and Driver Seat Buckle Switch (X120). If all are OK, check the Audible Warning Unit (Z109).
6. If the driver's door open/key-in-ignition tone is not heard, check the Driver Door Switch (X118) by opening the driver's door and seeing that the interior lights come on. If OK, check the PW wire, WP wire and the Ignition Key Switch (X177). If all are OK, check the Audible Warning Unit (Z109).
7. If the transfer box neutral tone is heard at all times, check the BK wire, B wire and Transfer Box Position Switch (X175). If all are OK, check the Audible Warning Unit (Z109).
4. If the low engine oil level/pressure warning light flashes with the oil level OK, do Test B.
5. If the low engine oil level/pressure warning light does not flash with the oil level low, do Test C.
6. If the check engine warning light does not operate properly, go to Section A1.
7. If no tone is heard when the transfer box is in position N, do Test D.
8. If the service engine warning light does not light at the specified emissions service interval, do Test E.
9. If the seatbelt and speed alarm does not operate, do Test F.
10. If any warning light not mentioned above does not operate properly, check the associated wires, switches and components.

SYSTEM DIAGNOSIS

1. If the charge warning light does not operate, go to Section B1 or B2.
2. If the ABS warning light does not operate, go to Section D1.
3. If the low engine oil level/pressure warning light remains illuminated, with the oil pressure OK, do Test A.

THIS PAGE HAS BEEN INTENTIONALLY LEFT BLANK

Test A

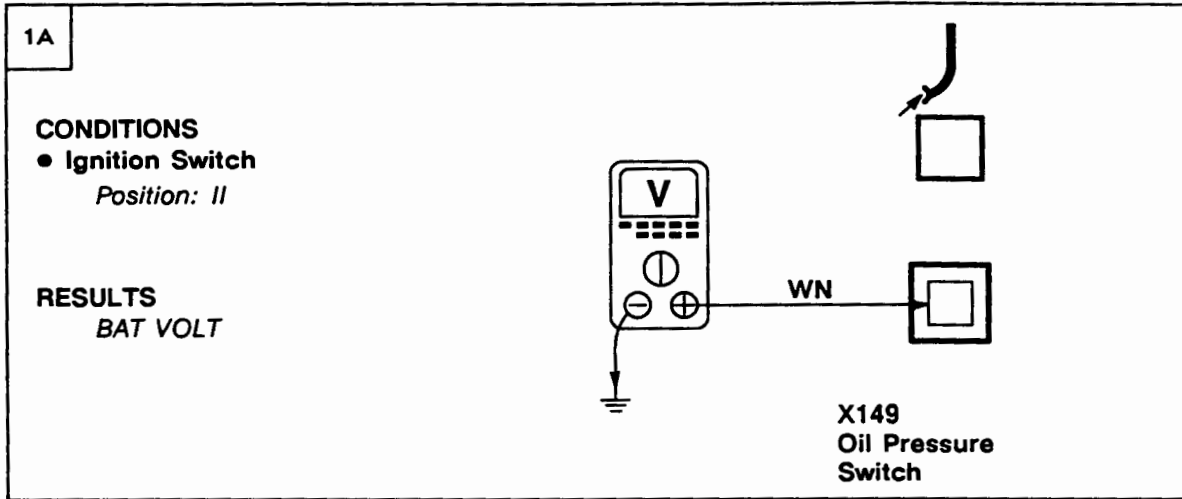

OK PROBLEM CAUSE

- WN Wire
- Engine Oil Level Monitor Unit
- Heated Front Screen Timer Unit

OK PROBLEM CAUSE

- Oil Pressure Switch

Test B

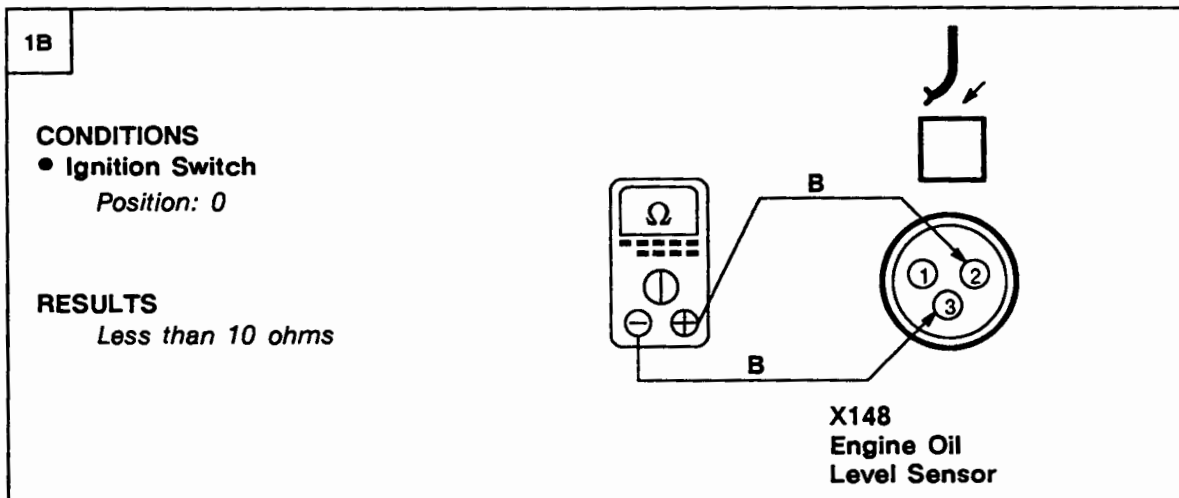

OK PROBLEM CAUSE

- Engine Oil Level Sensor

OK PROBLEM CAUSE

- WB Wire
- Engine Oil Level Monitor Unit

Test C

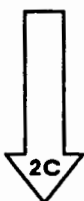
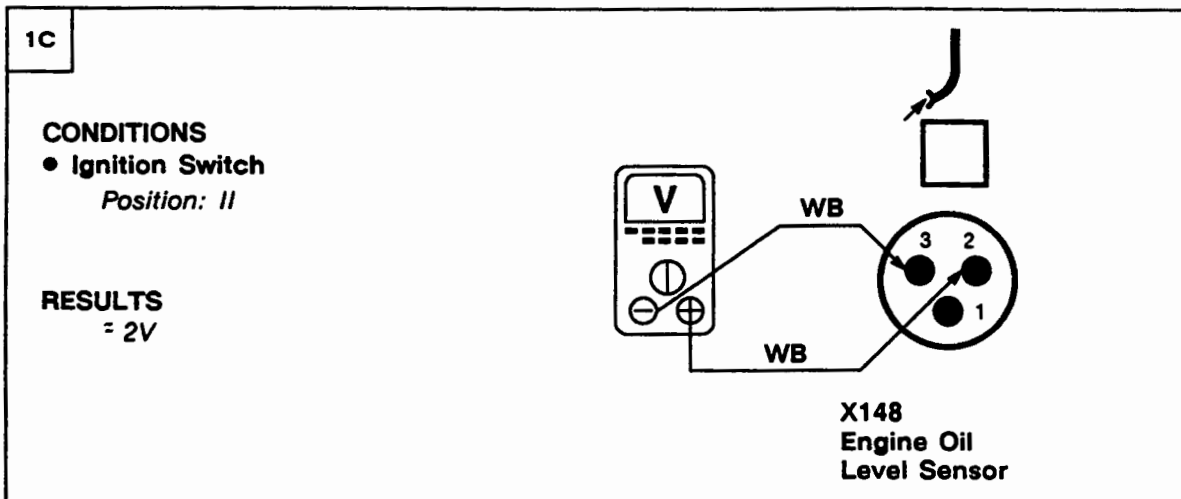

PROBLEM CAUSE
- Engine Oil Level Sensor

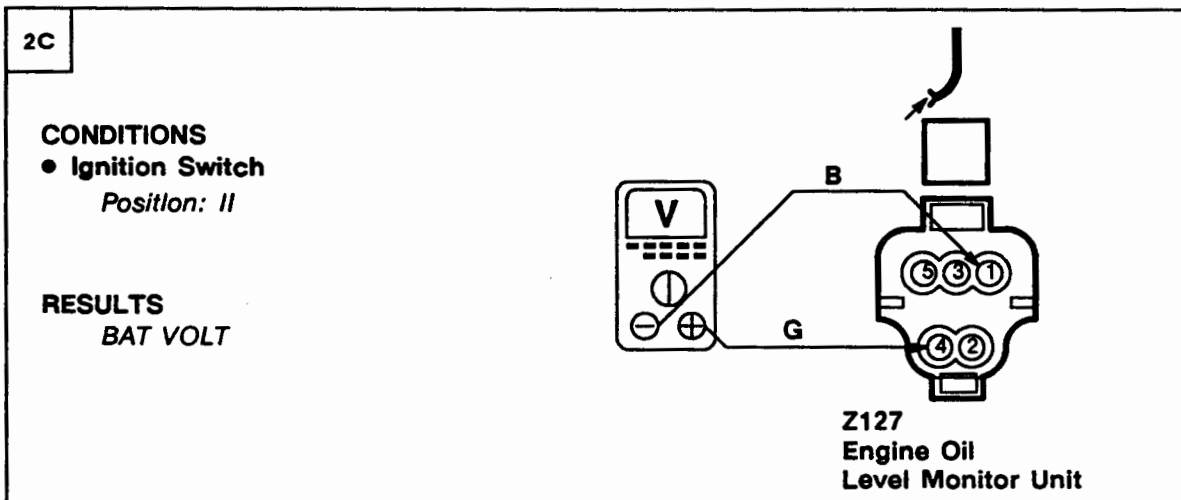

PROBLEM CAUSE
- B Wire
- G Wire
- F E4 Fuse



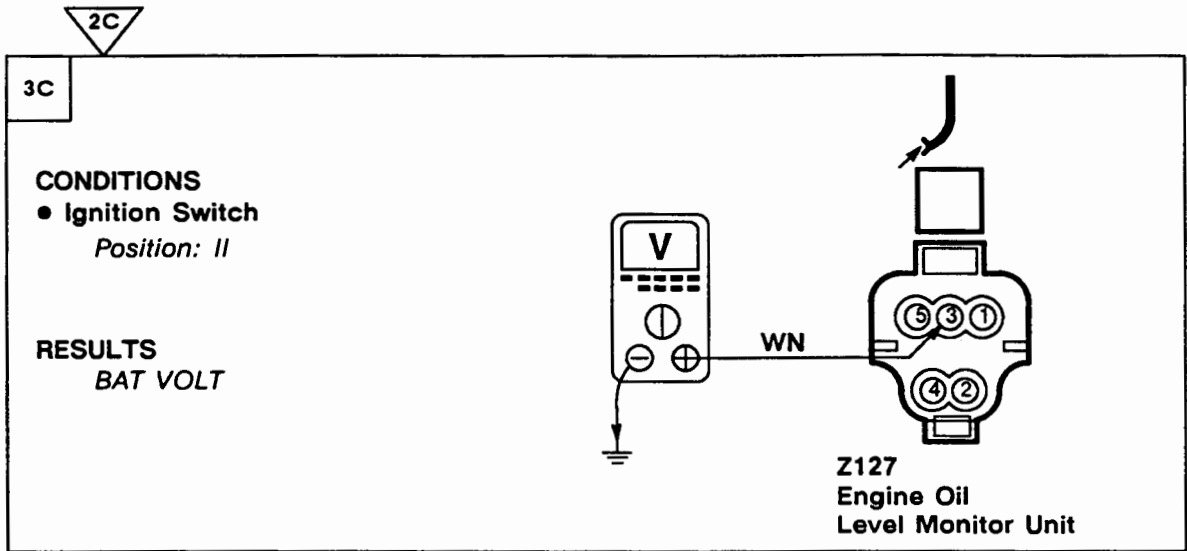

OK PROBLEM CAUSE
 - WN Wire
 - Bulb

OK PROBLEM CAUSE
 - Engine Oil Level Monitor
 Unit

Test D

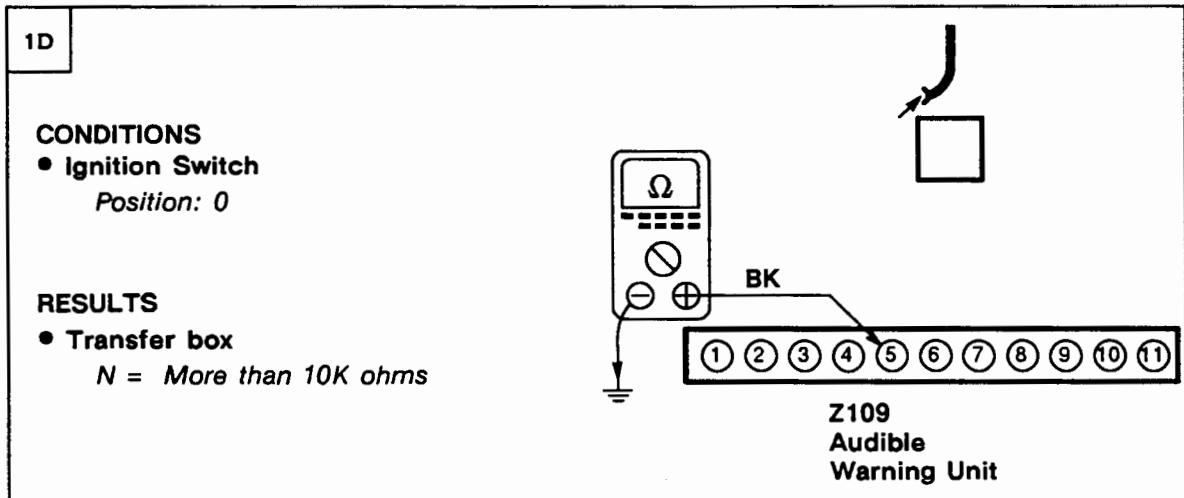

OK PROBLEM CAUSE
 - BK Wire
 - Transfer Box Position Switch

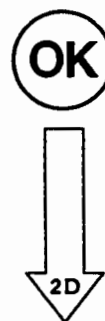

E3 ETM

1992 RANGE ROVER

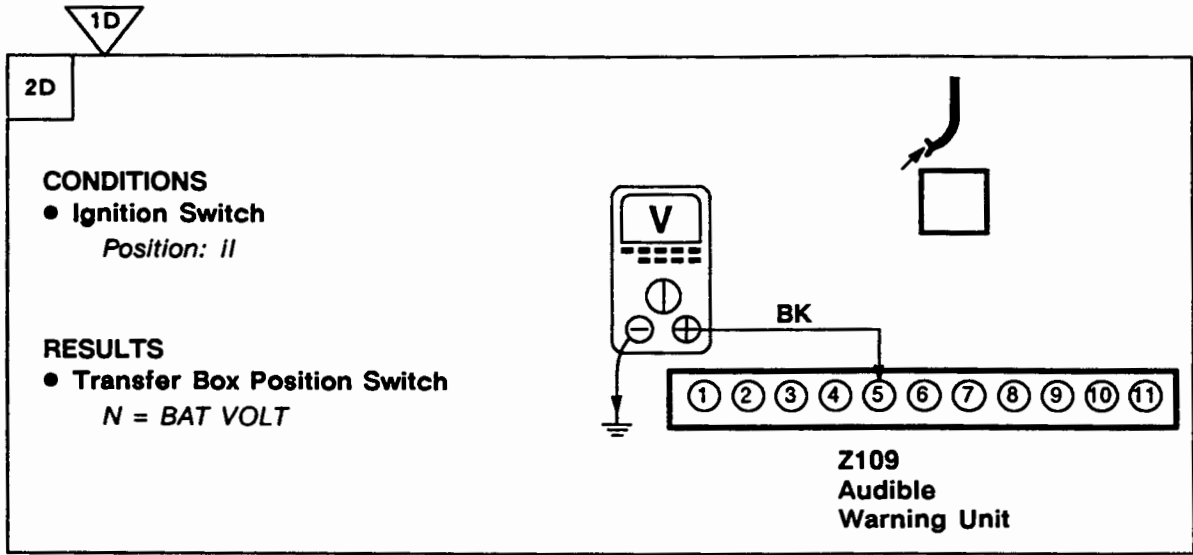

PROBLEM CAUSE

- G Wire
- K139



PROBLEM CAUSE

- Audible Warning Unit

Test E

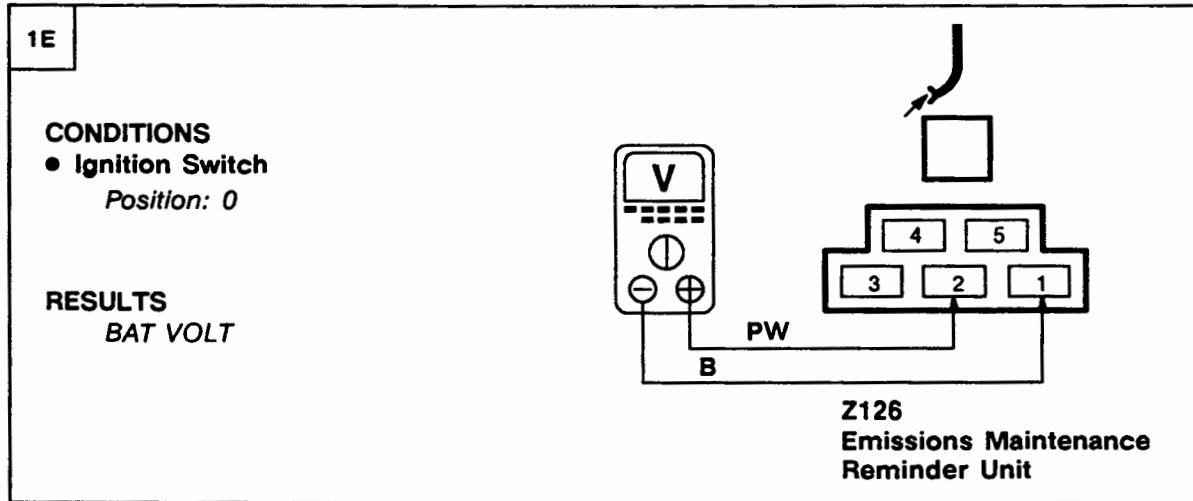

PROBLEM CAUSE

- B Wire
- PW Wire



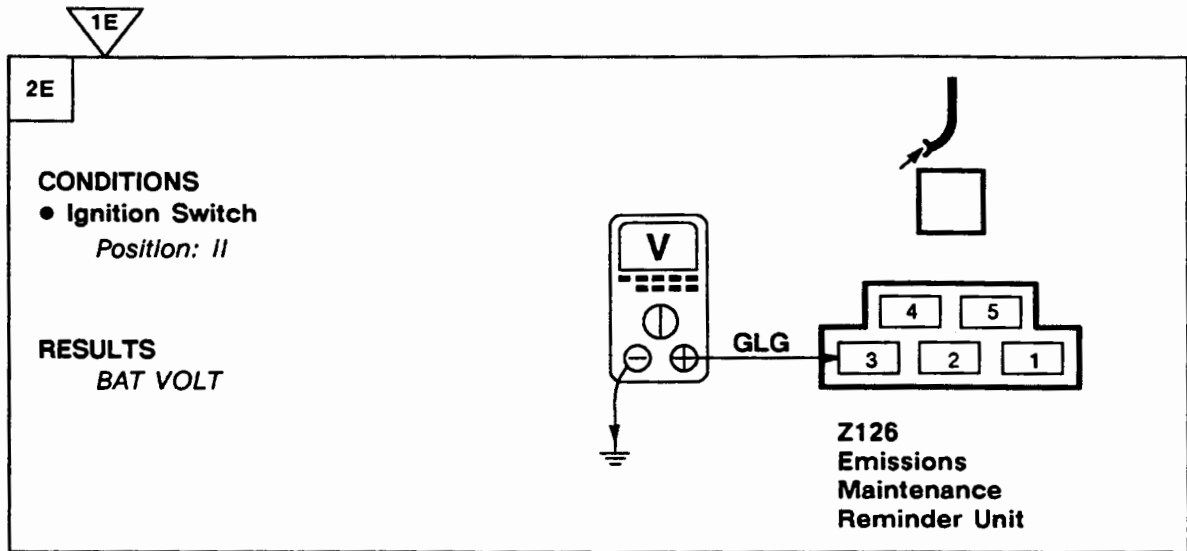

OK PROBLEM CAUSE
 - GLG Wire

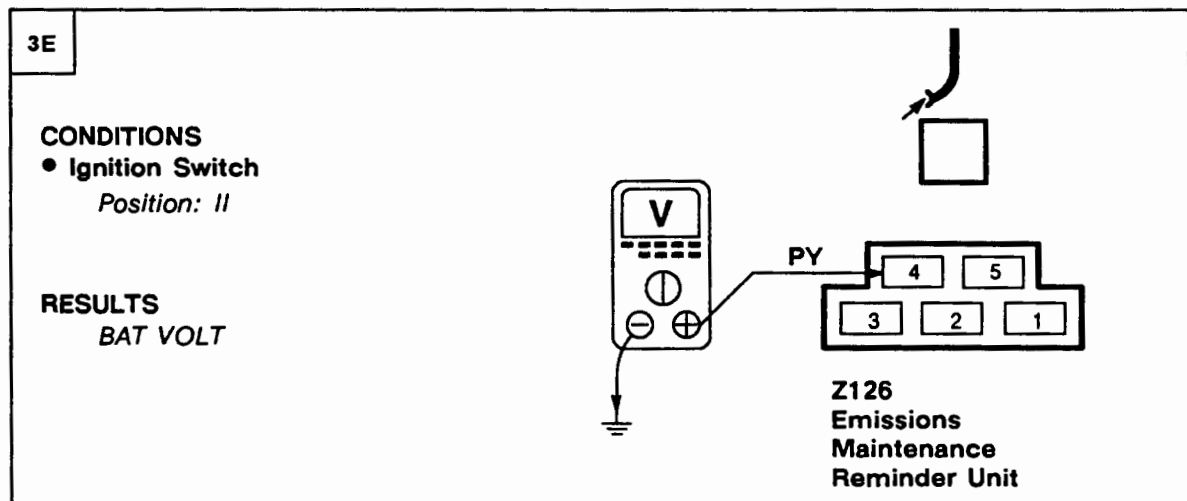
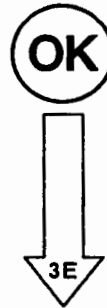

OK PROBLEM CAUSE
 - PY Wire
 - Bulb



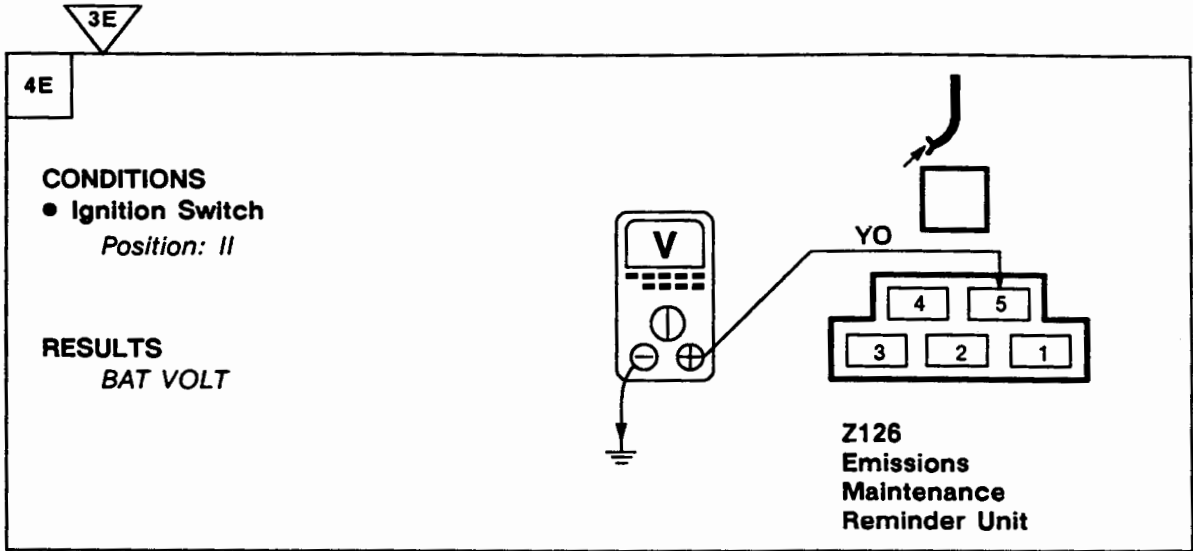

PROBLEM CAUSE
- YO Wire



PROBLEM CAUSE
- Emissions Maintenance
Reminder Unit

Test F

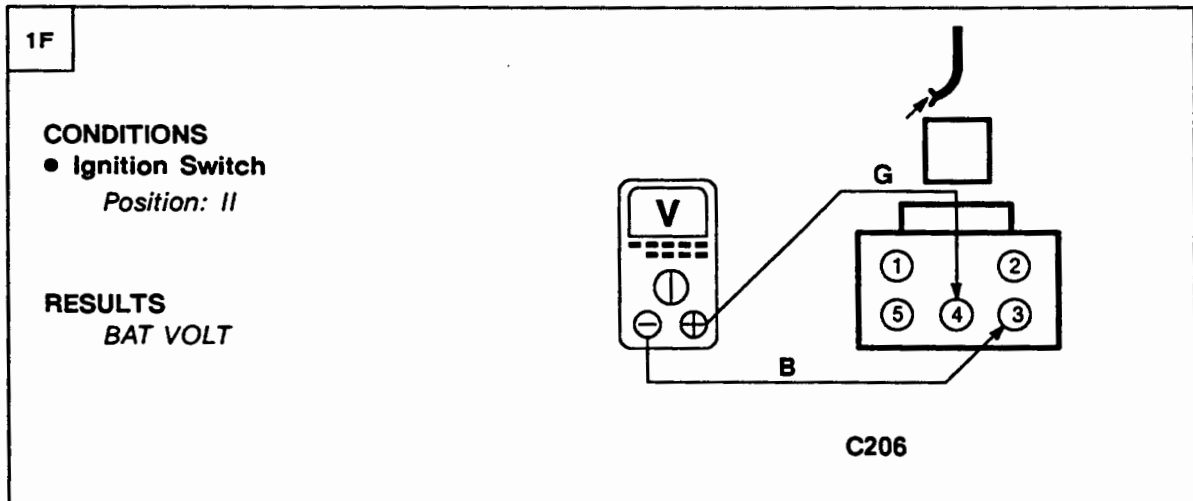

PROBLEM CAUSE
- G Wire
- B Wire

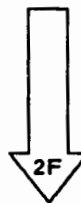

2F

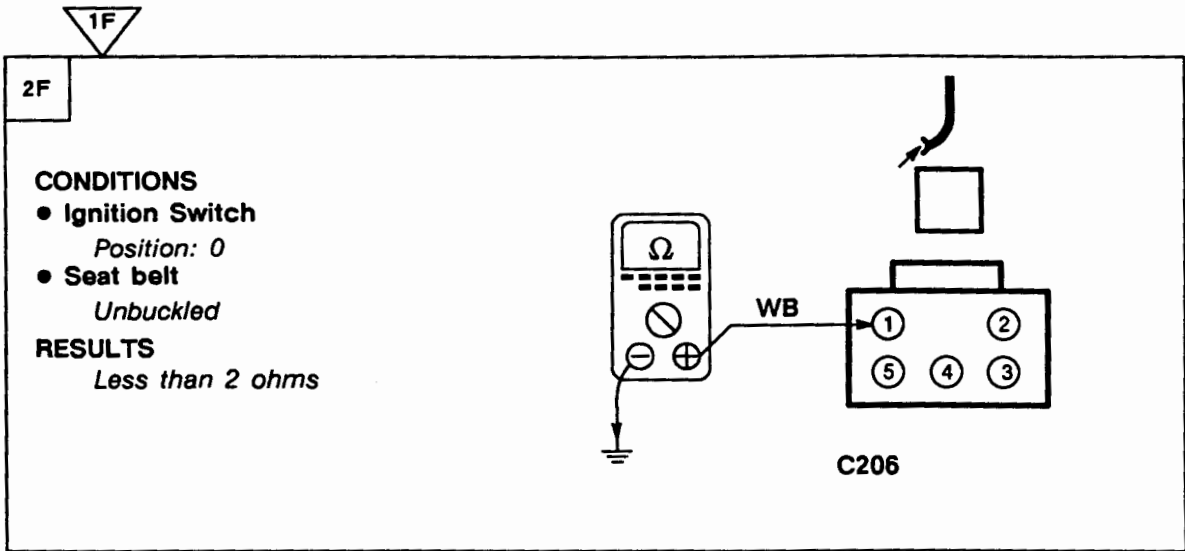

OK PROBLEM CAUSE

- WB Wire
- B Wire
- Driver Seat Buckle Switch

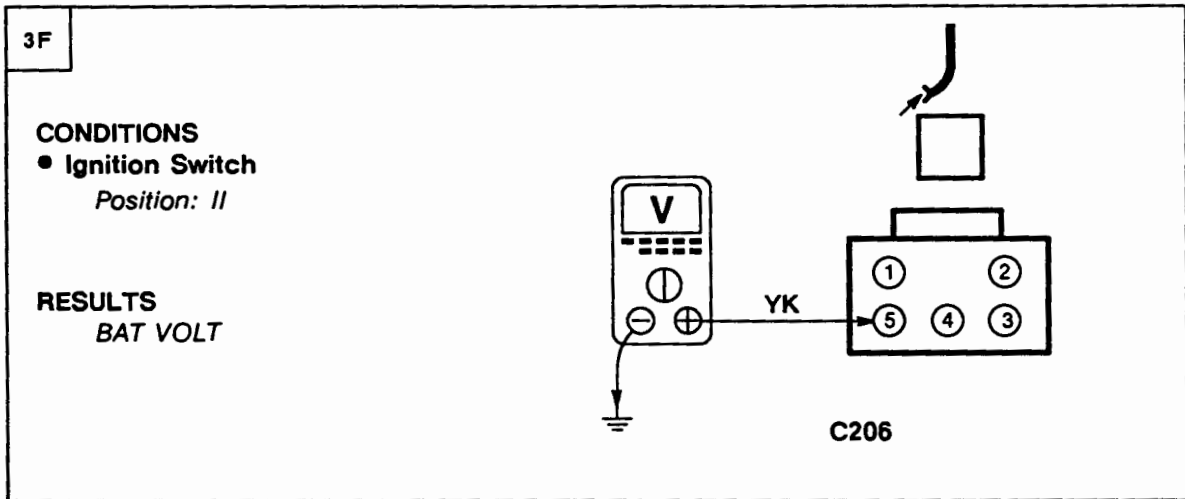

OK PROBLEM CAUSE

- YK Wire

OK PROBLEM CAUSE

- Seatbelt And Speed Warning Unit

1992 RANGE ROVER

KEY INFORMATION

CIRCUIT DIAGRAMS

- Circuit diagrams are arranged so that current flow is from the top of the diagram (current source) to the bottom of the diagram (earth).
- Only those components that work together in the circuit are shown. If only part of a component is used in the circuit, then only that part of the component is shown.

Remember:

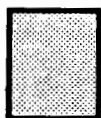

Entire component

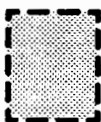

Part of a component

TERMINAL NUMBER

50

DESIGNATION

Battery voltage: Ignition Switch in position III

30

Battery voltage: supplied constantly

15

Battery voltage: Ignition Switch in position II or III

R

Battery voltage: Ignition Switch in positions I, II

31

Earth

See Introduction (i) for additional circuit diagram symbols.

DIAGNOSIS

- If the diagram is accompanied by text:
 - Read the Circuit Operation before proceeding with the electrical diagnosis.
 - Read the Troubleshooting Hints before performing the System Diagnosis.
 - Tests follow the System Diagnosis.
 - When performing the System Diagnosis, be certain that all components disconnected in previous steps are reconnected unless otherwise directed.

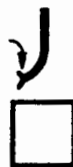

Component is disconnected.
Backprobe harness connector



Component is connected.
Backprobe harness connector



Component is disconnected.
Probe component



Component is disconnected.
Probe harness connector



Probe in-line connector