

### CIRCUIT OPERATION

The standard electronically-tuned audio system consists of an AM/FM cassette control head, an Antenna Amplifier (Z105) and 6 speakers. The control head is equipped with an anti-theft feature which makes the unit inoperative once battery power is removed. A 5 digit security code must be entered to restore power to the unit.

Battery voltage is provided to the control head at all times through the PW wire. In addition to monitoring the anti-theft feature, this input keeps the preset station memory alive.

Whenever battery power to the unit is lost, the anti-theft code must be entered and the preset stations must be reprogrammed.

When the Radio (Z111) and the ignition are turned on, the voltage signal through the LGK wire to the control head 'wakes up' the unit. The Radio (Z111) plays, the VF display comes on and the control unit buttons illuminate.

When the park lamps or headlamps are turned on, a voltage signal is sent through the RB wire to dim the VF display and control buttons for night driving. The VF display and control buttons can also be variably dimmed. This is controlled by the Instrument Illumination Rheostat (Z143). When the control is rotated, a variable voltage is sent to the control unit through the RN wire.

Radio (Z111) signals are received via a coaxial cable from the rear screen and Antenna Amplifier (Z105). The amplifier filters and boosts the signal from the rear screen. The amplifier also contains compensating circuitry which cleans up higher frequencies when the heated rear screen is operating.

Wire Colour Chart

B- Black	P- Purple
G- Green	R- Red
K- Pink	S- Grey
L- Light	U- Blue
N- Brown	W- White
O- Orange	Y- Yellow

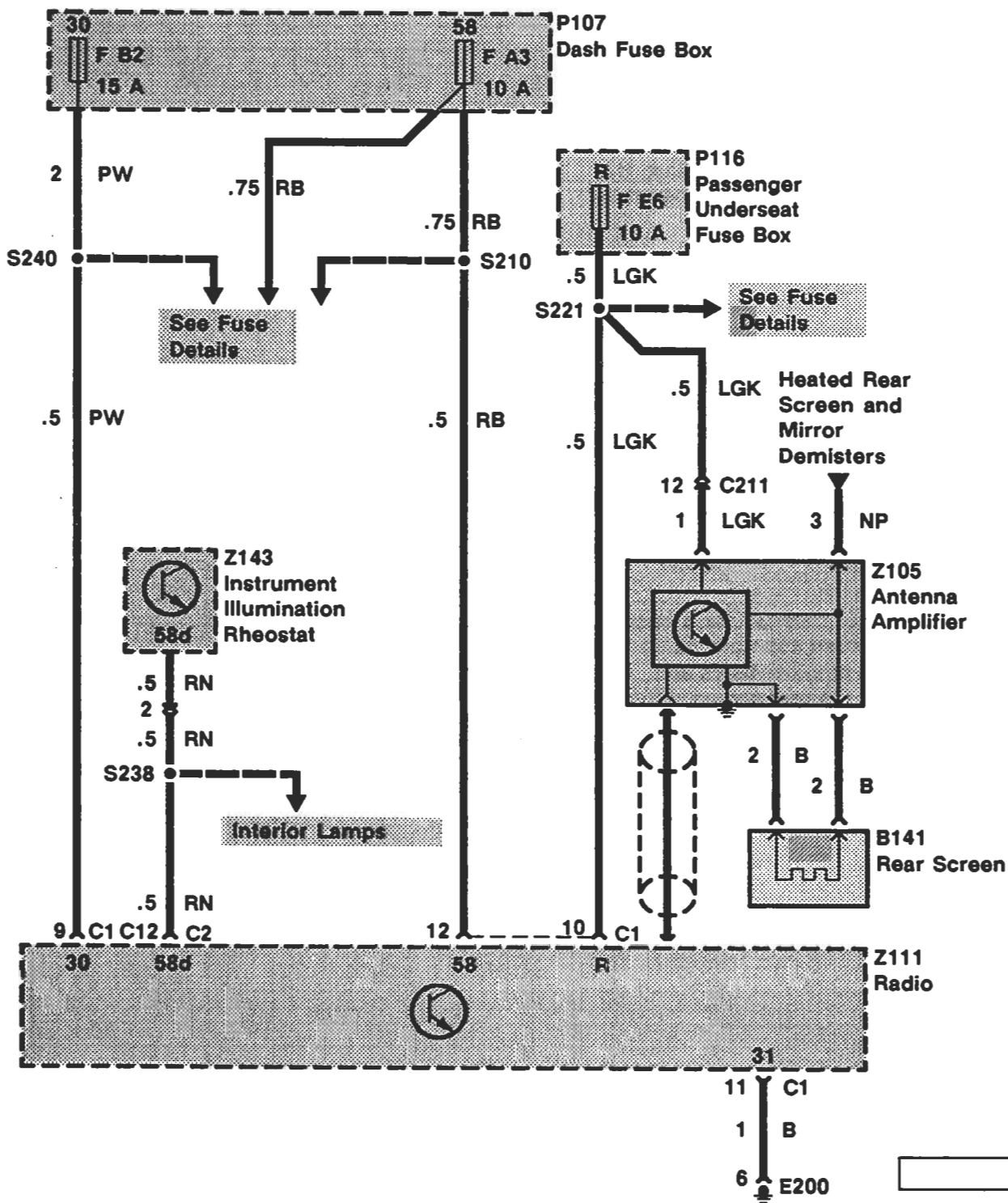

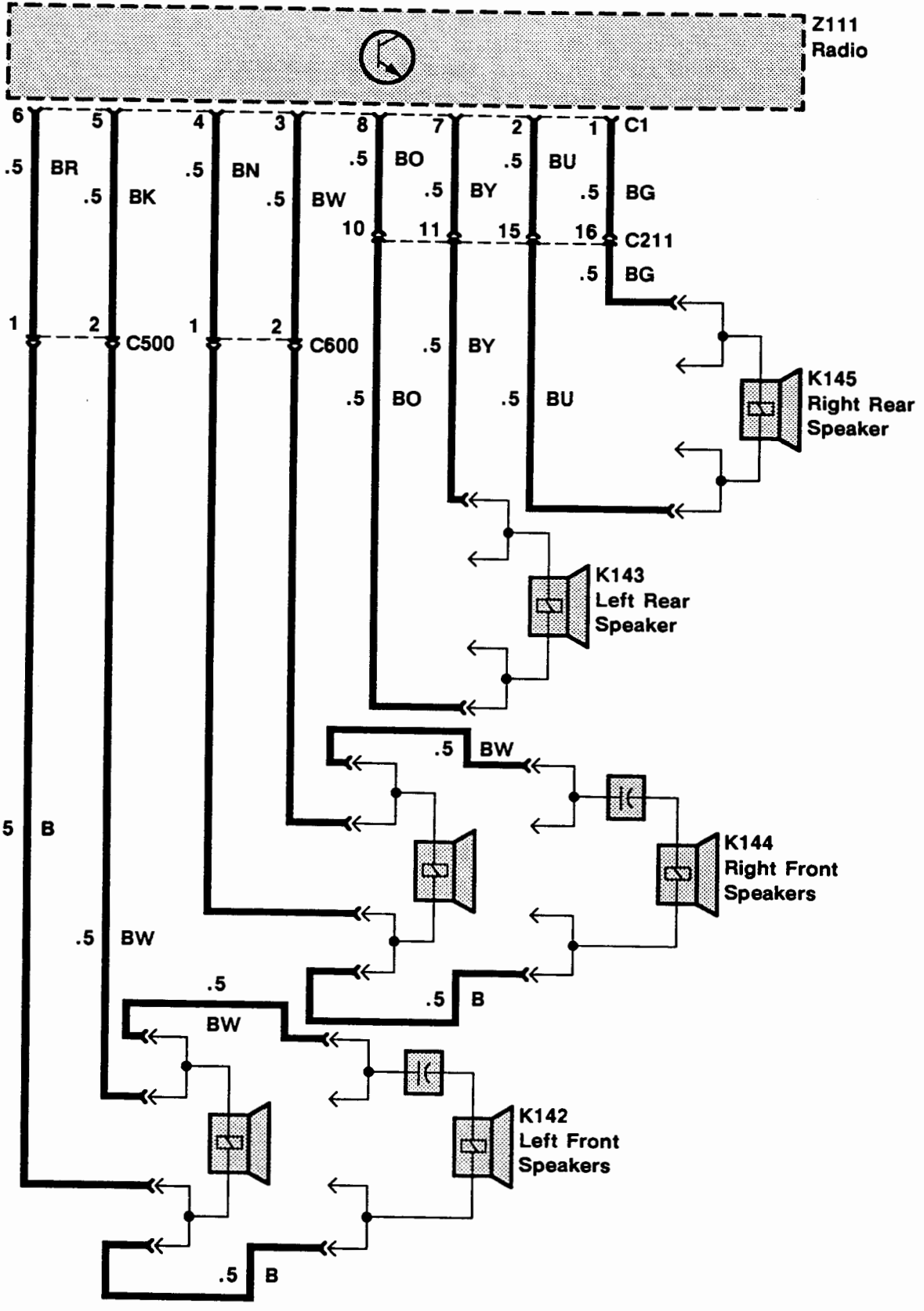
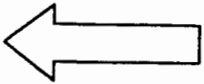

**TROUBLESHOOTING HINTS**

1. Check fuses F B2 and F E6.
2. Check that Radio (Z111) connectors and coaxial cable are tight and properly connected.
3. For proper Radio (Z111) noise diagnosis, take the vehicle outside where signals are strong. Close the hood and keep away from metal buildings or other sources of Radio interference.
4. If Radio (Z111) noise is excessive when an accessory is on, install a Radio noise suppression capacitor to the power lead of that accessory.
5. If Radio (Z111) noise is excessive at all times, check antenna wiring. If OK, check spark plugs, spark plug wiring and wiring close to the ignition system which could transmit noise to the Radio (Z111) wiring.
6. If the Radio (Z111) is inoperative and 'code' is being shown on the display, follow the instructions below.

**Security Code Instructions**

1. Obtain 5-digit security code from vehicle owner or manufacturer.
2. Enter the code number using the Radio (Z111) push-button selectors.

NOTE: If the correct code is not entered in 3 successive attempts, the Radio (Z111) will not accept another entry until the Radio has been left on for 1 hour with the ignition on.

NOTE: When entering the code, be sure to complete the sequence numbering of that 5-digit code even if you made a mistake. For example, if the correct code number sequence is 43215 and you mistakenly enter 42 instead of 43, continue the code number sequence of 215 to complete that entry. A 'beep' will sound, 'code' will still be displayed and the Radio will not operate. Re-enter the correct code 43215 and the Radio will operate.

NOTE: If an audible 'beep' is heard while entering the code, STOP immediately. Begin entering the code again, starting with the first number of the 5-digit code.

NOTE: If a push-button is touched accidentally when the ignition is off, a warning tone will sound. Turn the ignition on and the tone will stop.

**SYSTEM DIAGNOSIS**

1. If Radio (Z111) does not operate at all, do Test A.
2. If Radio (Z111) scans past all frequencies when in seek mode and hiss is present over most stations, do Test B. (Test B assumes that the heated rear screen operates. If it does not, troubleshoot that system first.)
3. If VF display does not dim when headlamps or park lamps are turned on, do Test C.
4. If VF display intensity does not vary when Instrument Illumination Rheostat (Z143) is varied, do Test D.
5. If one or more speakers do not operate, do Test E.



**Test A**

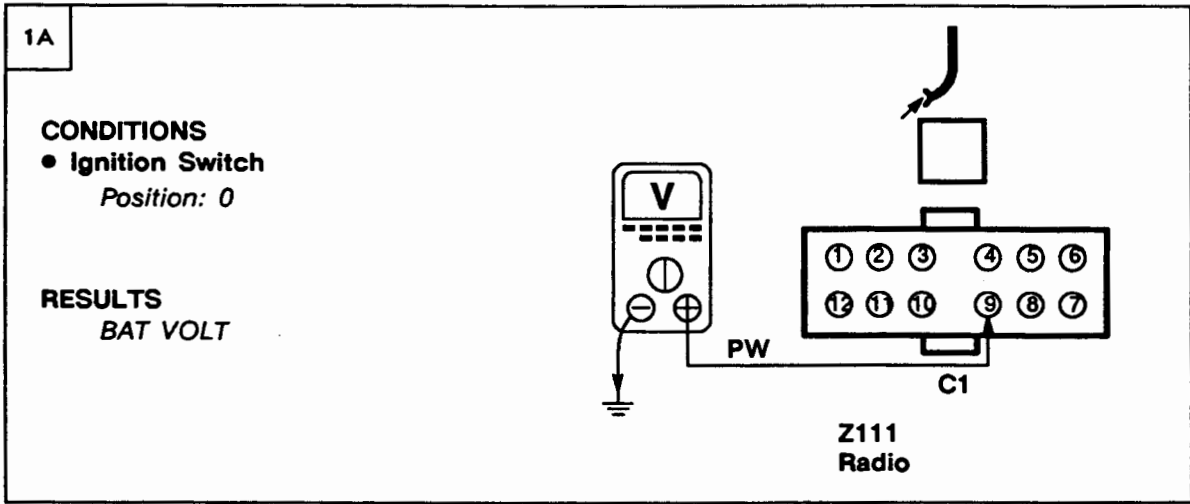

**PROBLEM CAUSE**  
 - PW Wire

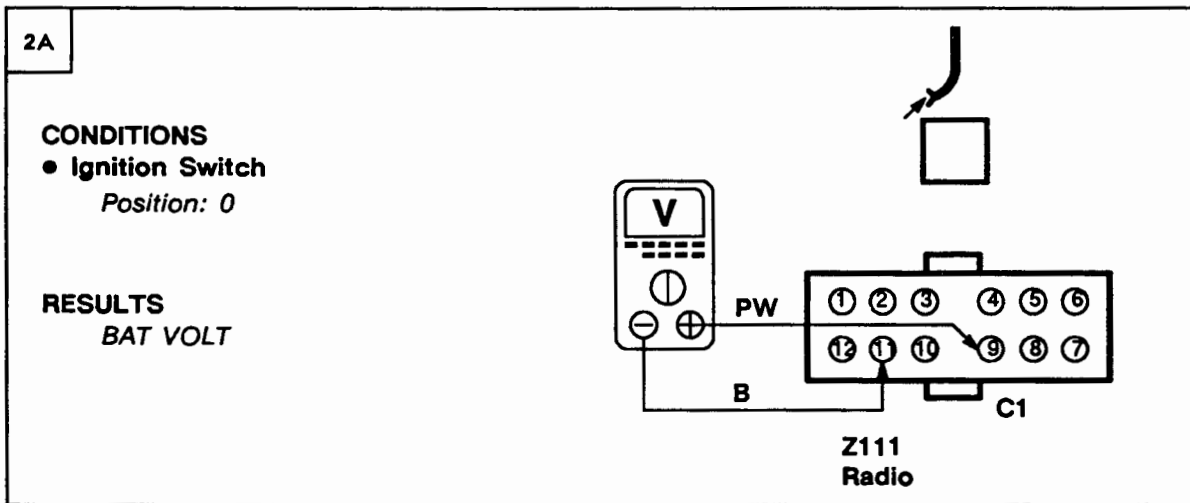
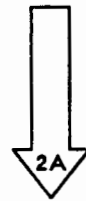

**PROBLEM CAUSE**  
 - B Wire



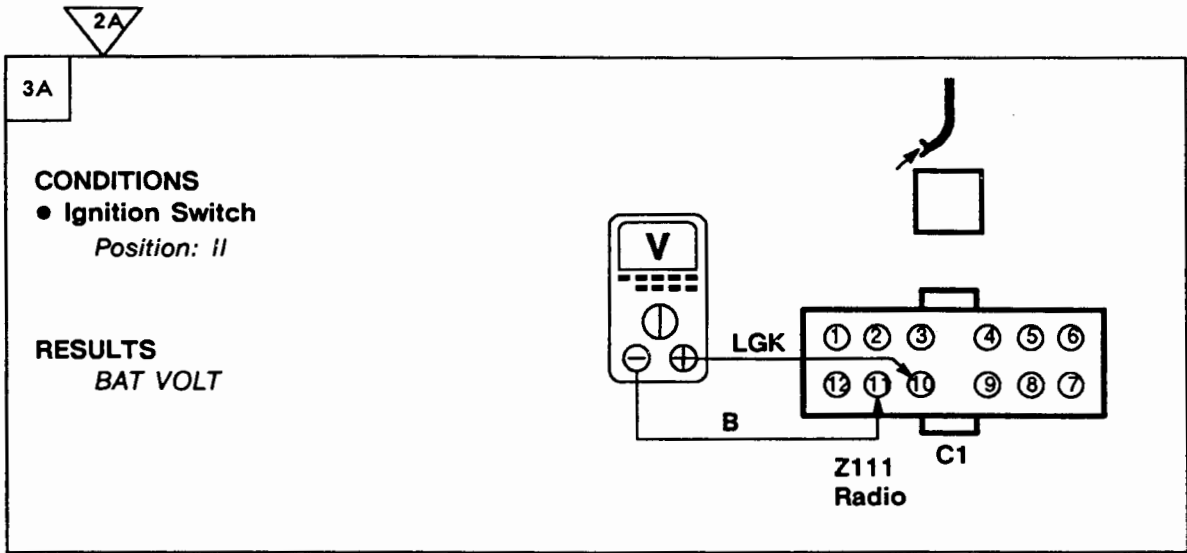

PROBLEM CAUSE  
- LGK Wire



PROBLEM CAUSE  
- Radio

**Test B**

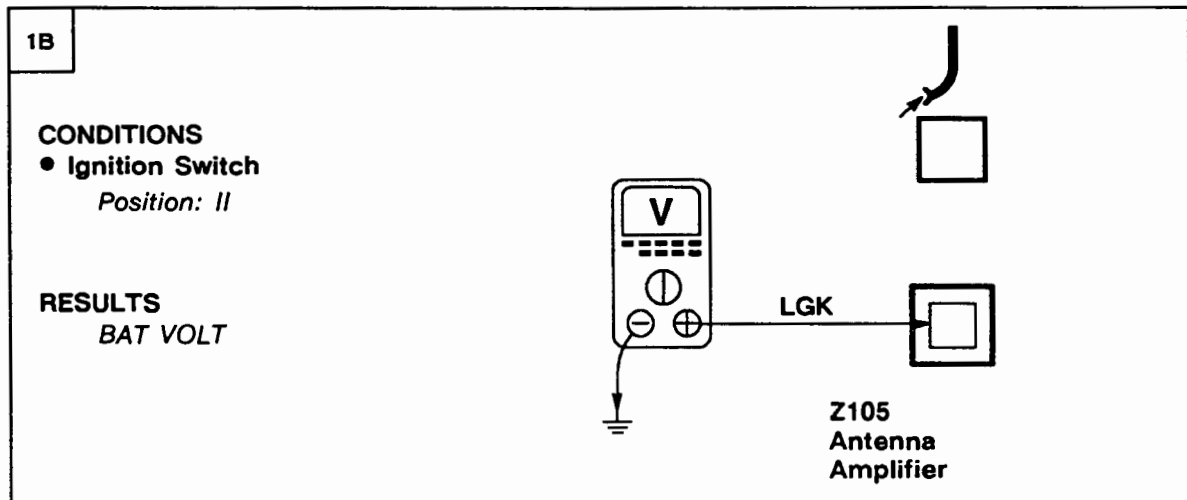

PROBLEM CAUSE  
- LGK Wire



PROBLEM CAUSE  
- Coaxial Cable  
- Radio  
- Antenna Amplifier

**Test C**

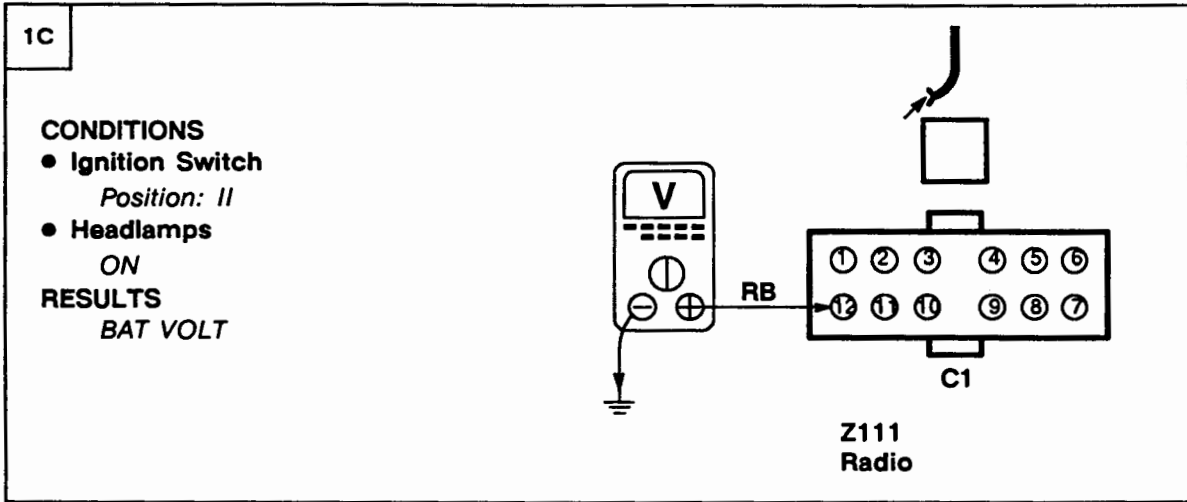

**PROBLEM CAUSE**  
- RB Wire  
- F A3 Fuse



**PROBLEM CAUSE**  
- Radio

**Test D**

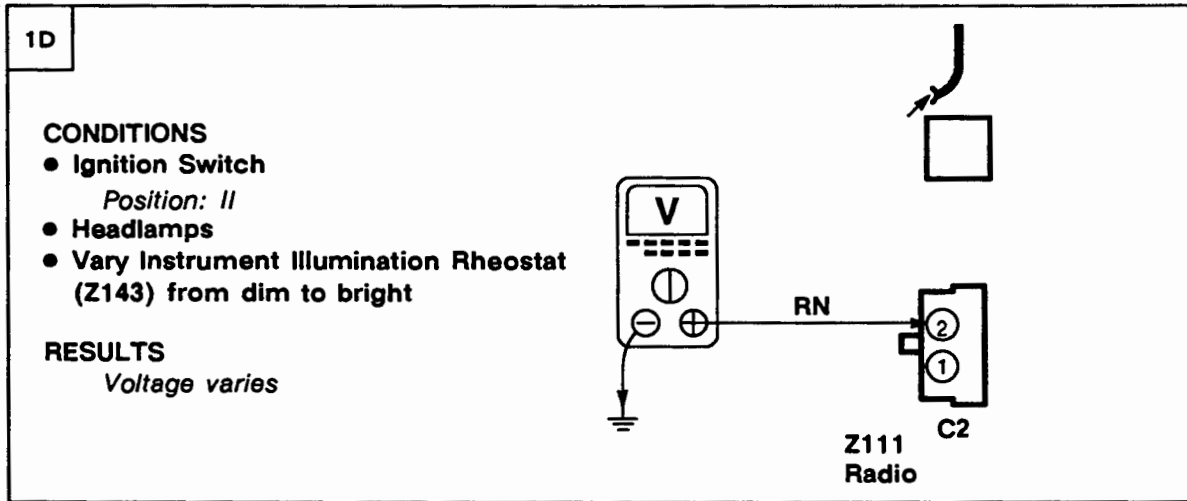

**PROBLEM CAUSE**  
- RN Wire  
- Instrument Illumination Rheostat



**PROBLEM CAUSE**  
- Radio



Test E

1E

**CONDITIONS**

- Connect for less than 1 second

**RESULTS**  
*Speaker 'pops'*

Speaker

**OK** PROBLEM CAUSE  
- Speaker

**OK** PROBLEM CAUSE  
- Speaker wiring  
- Radio

# 1992 RANGE ROVER

## KEY INFORMATION

### CIRCUIT DIAGRAMS

- Circuit diagrams are arranged so that current flow is from the top of the diagram (current source) to the bottom of the diagram (earth).
- Only those components that work together in the circuit are shown. If only part of a component is used in the circuit, then only that part of the component is shown.

#### Remember:

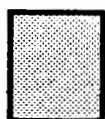

Entire component



Part of a component

### TERMINAL NUMBER

TERMINAL NUMBER	DESIGNATION
50	Battery voltage: Ignition Switch in position III
30	Battery voltage: supplied constantly
15	Battery voltage: Ignition Switch in position II or III
R	Battery voltage: Ignition Switch in positions I, II
31	Earth

See Introduction (i) for additional circuit diagram symbols.

### DIAGNOSIS

- If the diagram is accompanied by text:
  - Read the Circuit Operation before proceeding with the electrical diagnosis.
  - Read the Troubleshooting Hints before performing the System Diagnosis.
  - Tests follow the System Diagnosis.
  - When performing the System Diagnosis, be certain that all components disconnected in previous steps are reconnected unless otherwise directed.



Component is disconnected.  
Backprobe harness connector



Component is connected.  
Backprobe harness connector

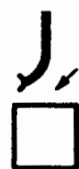

Component is disconnected.  
Probe component



Component is disconnected.  
Probe harness connector



Probe in-line connector

### CIRCUIT OPERATION

The Pioneer CD audio system consists of an AM/FM cassette/CD control head, an Antenna Amplifier (Z105), 2 sound system amplifiers, a 6 disc CD Changer (Z114) and (if equipped) a crossover and subwoofer. The control head is equipped with an anti-theft feature which makes the unit inoperative once battery power is removed. A 5 digit security code must be entered to restore power to the unit.

Battery voltage is provided to the control head at all times through the PW wire. In addition to monitoring the anti-theft feature, this input keeps the preset station memory alive.

Whenever battery power to the unit is lost, the anti-theft code must be entered and the preset stations must be reprogrammed.

When the Radio (Z111) and the ignition are turned on, the voltage signal through the LG and R wires to the control head 'wakes up' the unit. The Radio (Z111) plays, the VF display comes on and the control unit buttons illuminate. The VF display and control buttons can be variably dimmed. This is controlled by the Instrument Illumination Rheostat (Z143).

When the control is rotated, a variable voltage is sent to the control unit through the RN wire. Radio (Z111) signals are received via a coaxial cable from the rear screen and Antenna Amplifier (Z105). The amplifier filters and boosts the signal from the rear screen. The amplifier also contains compensating circuitry which cleans up higher frequencies when the heated rear screen is operating

Power is available to the CD Changer (Z114) at all times. It is operated from the control head when 'CD' is selected by pressing the BAND button. The control head communicates with the Changer (Z114) via a DIN cable.

The sound system amplifiers receive power with the ignition on. They become enabled when the Radio (Z111) is turned on, sending a voltage signal through the PY wires.

# E7 ETM

## 1992 RANGE ROVER

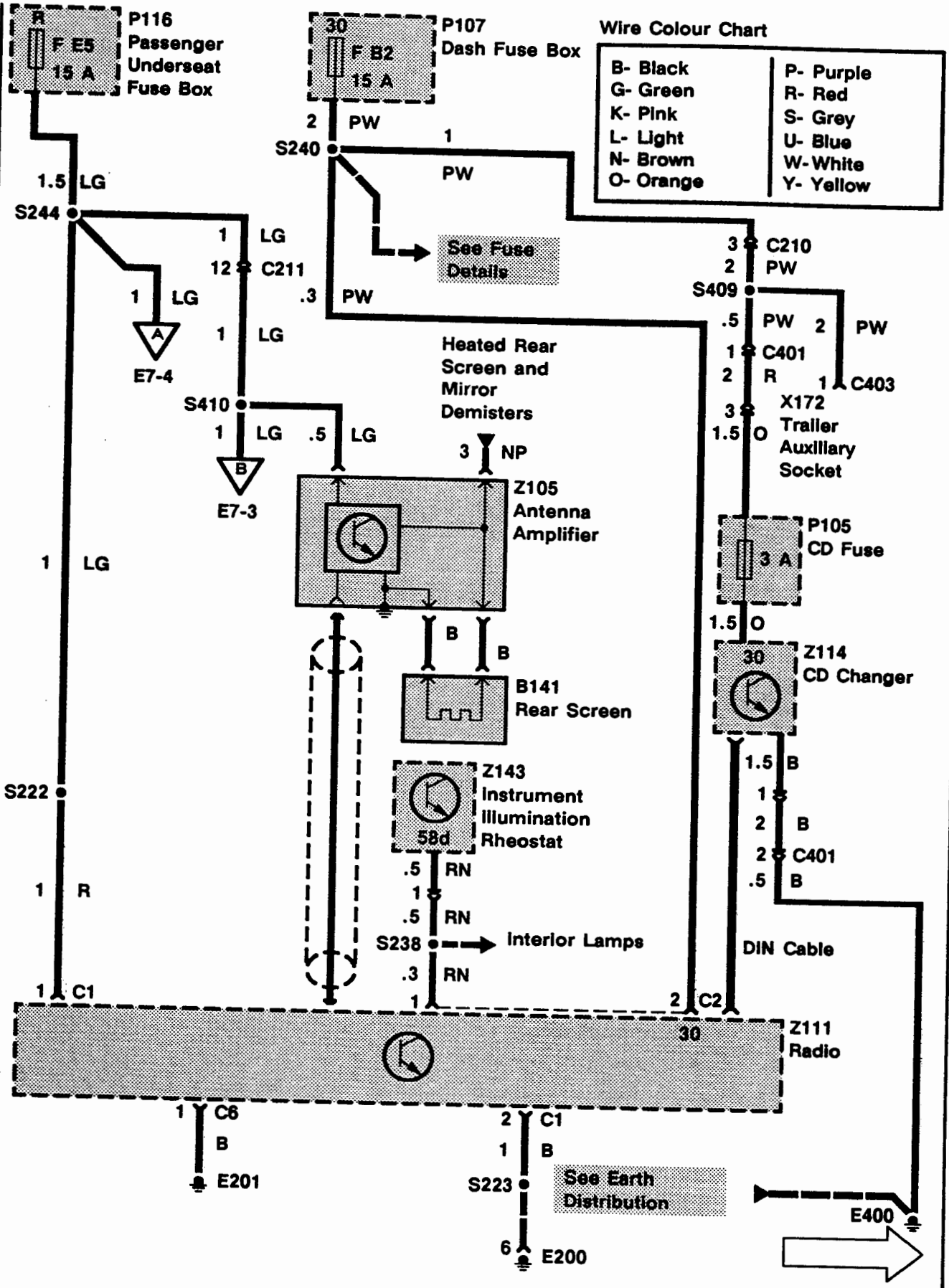

Wire Colour Chart

B- Black	P- Purple
G- Green	R- Red
K- Pink	S- Grey
L- Light	U- Blue
N- Brown	W- White
O- Orange	Y- Yellow

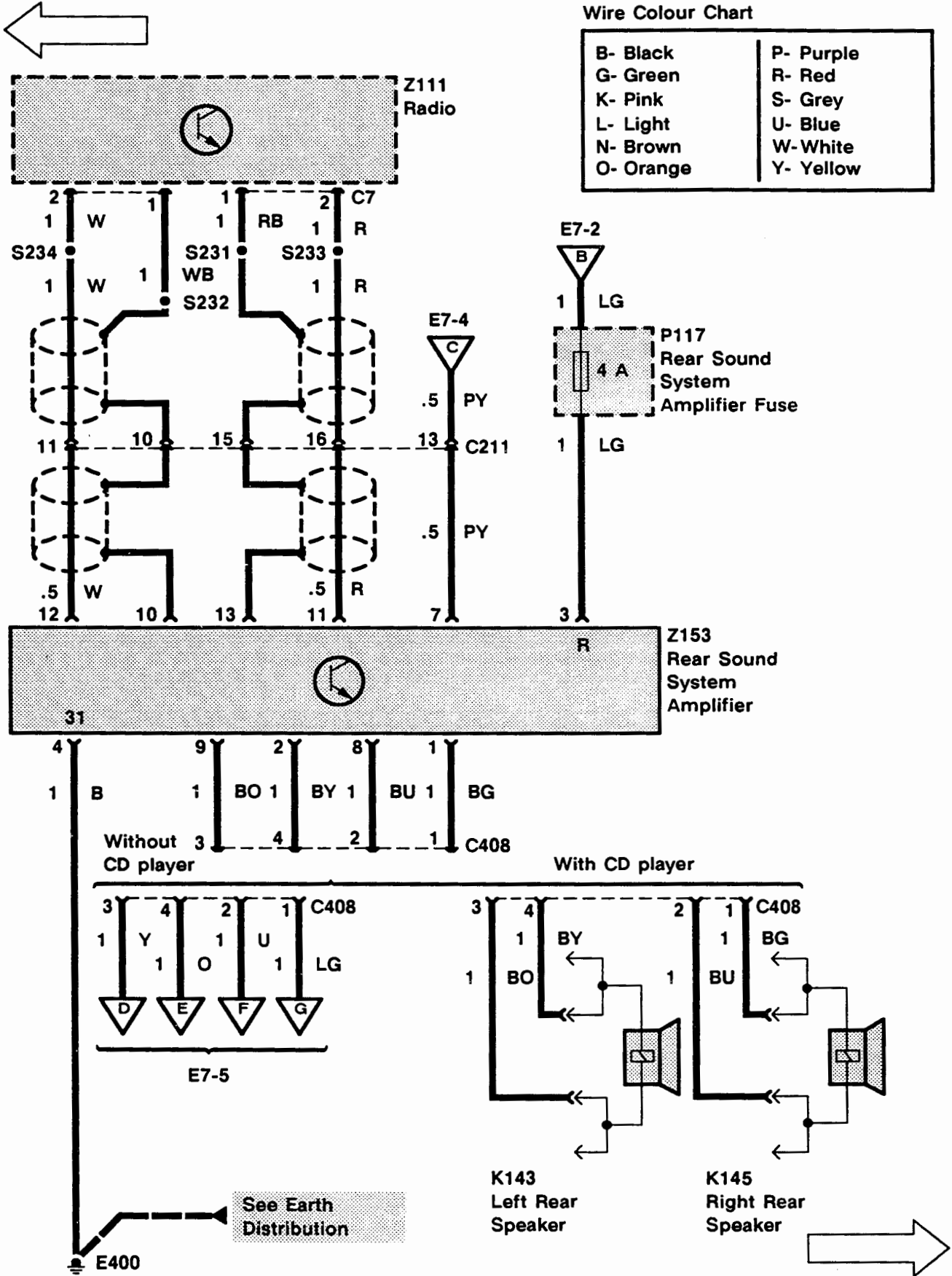

# E7 ETM

## 1992 RANGE ROVER

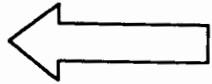

### Wire Colour Chart

B- Black	P- Purple
G- Green	R- Red
K- Pink	S- Grey
L- Light	U- Blue
N- Brown	W- White
O- Orange	Y- Yellow

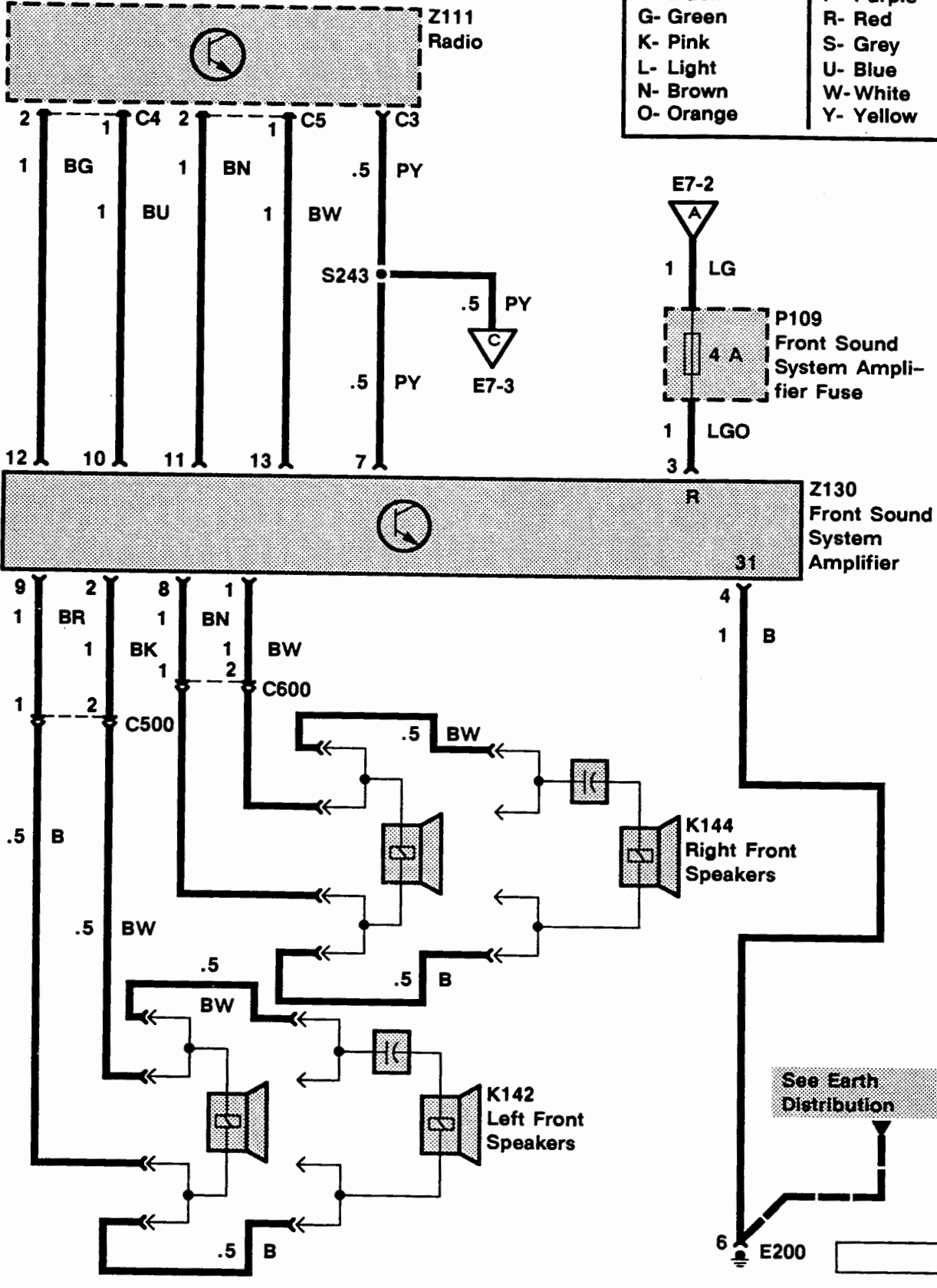

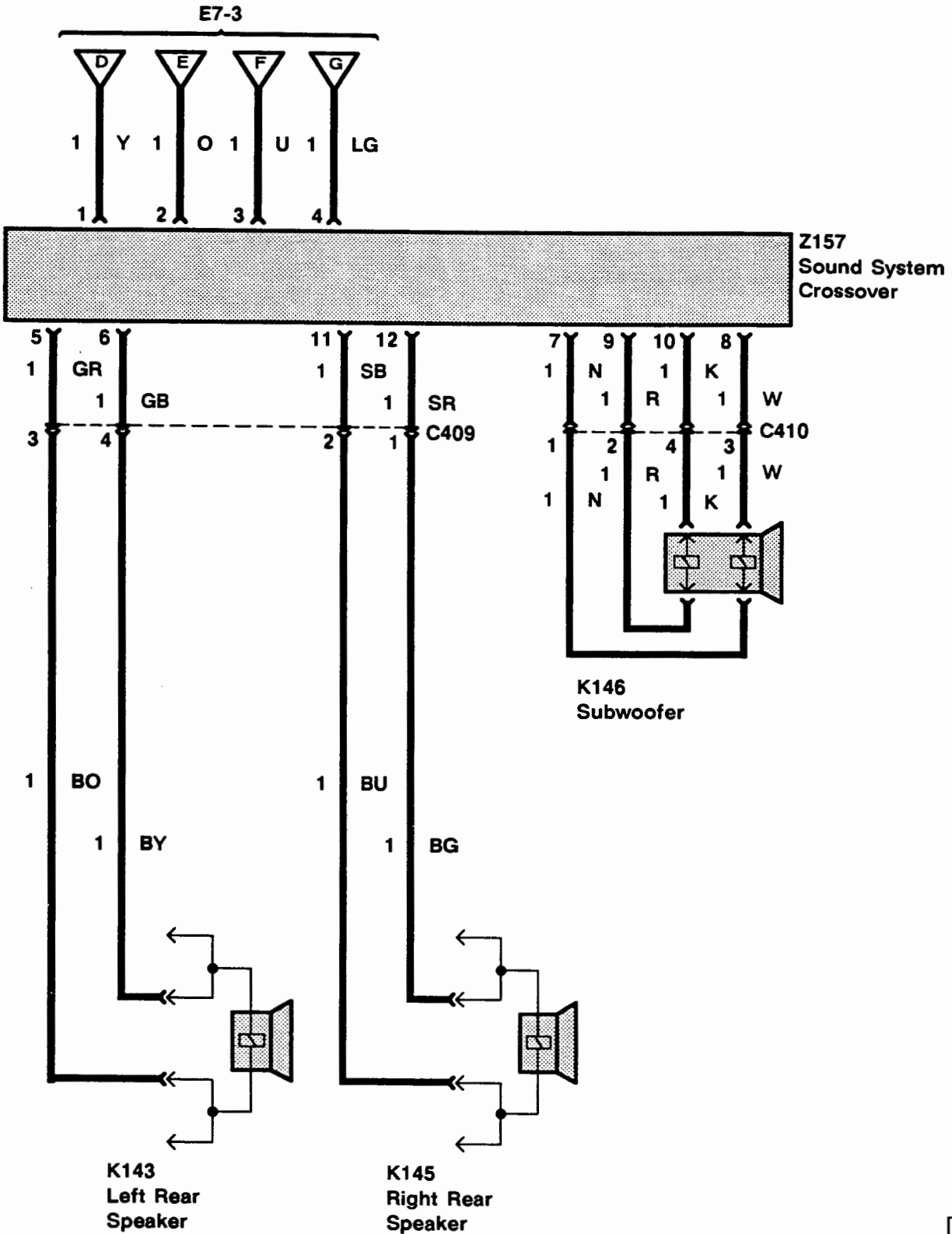
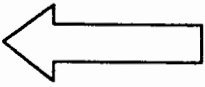

**TROUBLESHOOTING HINTS**

1. Check fuses F B2 and F E5.
2. Check that Radio (Z111) connectors and coaxial cable are tight and properly connected.
3. For proper Radio (Z111) noise diagnosis, take the vehicle outside where signals are strong. Close the hood and keep away from metal buildings or other sources of Radio interference.
4. If Radio (Z111) noise is excessive when an accessory is on, install a Radio noise suppression capacitor to the power lead of that accessory.
5. If Radio (Z111) noise is excessive at all times, check antenna wiring. If OK, check spark plugs (P118), spark plug wiring and wiring close to the ignition system which could transmit noise to the Radio wiring.
6. If the Radio (Z111) is inoperative and 'code' is being shown on the display, follow the instructions below.

**Security Code Instructions**

1. Obtain 5-digit security code from vehicle owner or manufacturer.
2. Enter the code number using the Radio (Z111) push-button selectors.

NOTE: If the correct code is not entered in 3 successive attempts, the Radio (Z111) will not accept another entry until the Radio has been left on for 1 hour with the ignition on.

NOTE: When entering the code, be sure to complete the sequence numbering of that 5-digit code even if you made a mistake. For example, if the correct code number sequence is 43215 and you mistakenly enter 42 instead of 43, continue the code number sequence of 215 to complete that entry. A 'beep' will sound, 'code' will still be displayed and the Radio will not operate. Re-enter the correct code 43215 and the Radio will operate.

NOTE: If an audible 'beep' is heard while entering the code, STOP immediately. Begin entering the code again, starting with the first number of the 5-digit code.

NOTE: If a push-button is touched accidentally when the ignition is off, a warning tone will sound. Turn the ignition on and the tone will stop.

**SYSTEM DIAGNOSIS**

1. If Radio (Z111) does not operate at all, do Test A.
2. If Radio (Z111) scans past all frequencies when in seek mode and hiss is present over most stations, do Test B. (Test B assumes that the heated rear screen operates. If it does not, troubleshoot that system first.)
3. If VF display intensity does not vary when Instrument Illumination Rheostat (Z143) is varied, do Test C.
4. If one or more (but not all) speakers do not operate, do Test D.
5. If only the CD Changer (Z114) does not operate, do Test E.



THIS PAGE HAS BEEN INTENTIONALLY LEFT BLANK

Test A

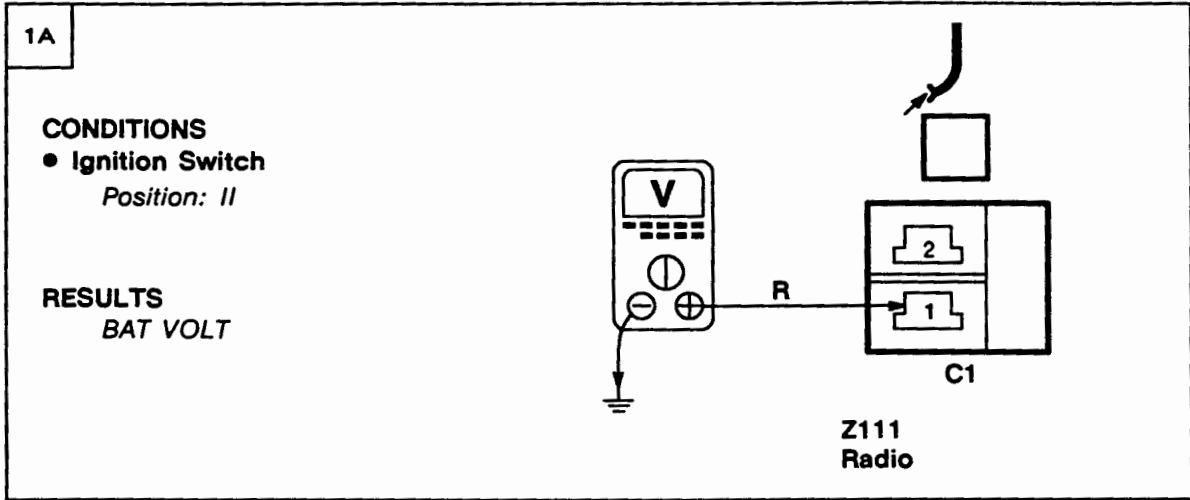

~~OK~~ PROBLEM CAUSE  
 - R Wire  
 - LG Wire

OK

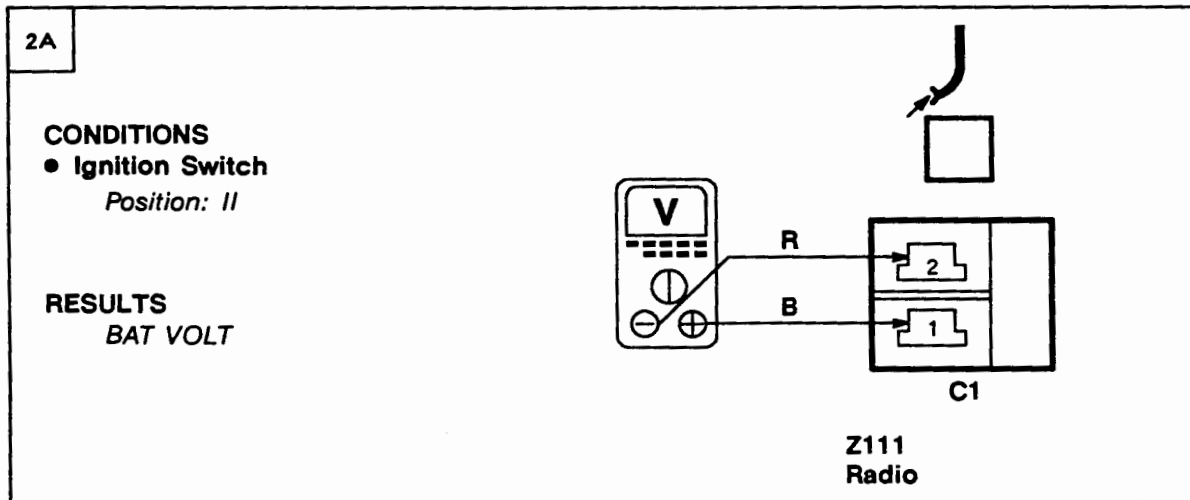

~~OK~~ PROBLEM CAUSE  
 - B Wire

OK



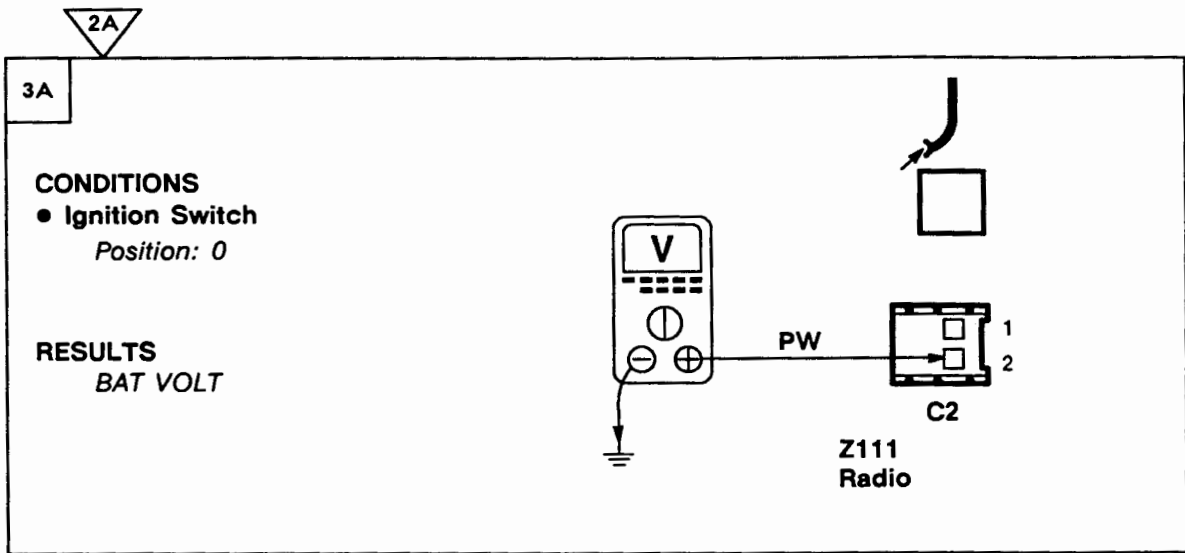

~~OK~~ PROBLEM CAUSE  
 - PW Wire

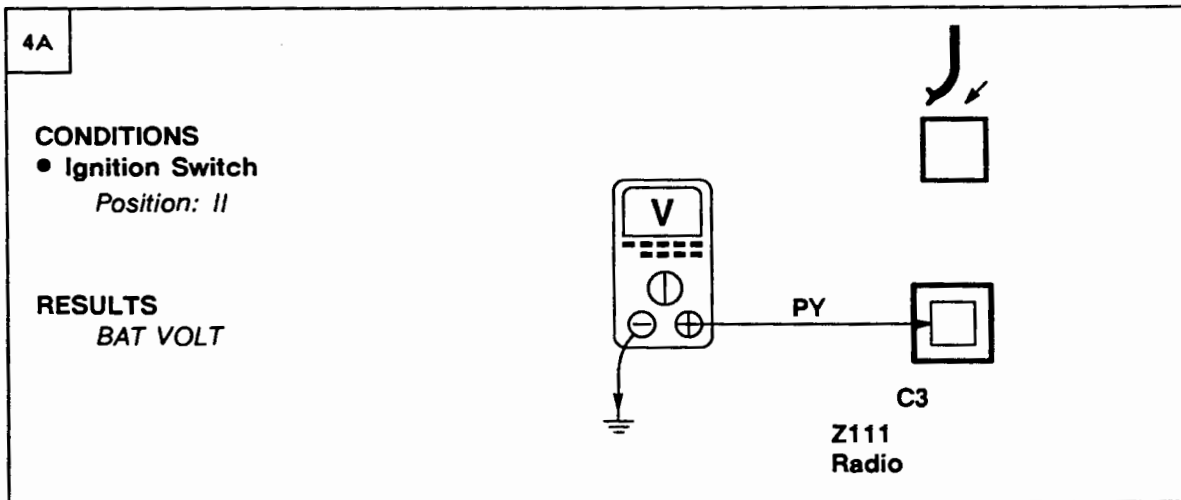
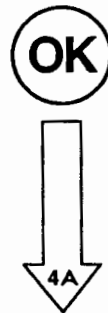

~~OK~~ PROBLEM CAUSE  
 - Radio

OK PROBLEM CAUSE  
 - PY Wire

**Test B**

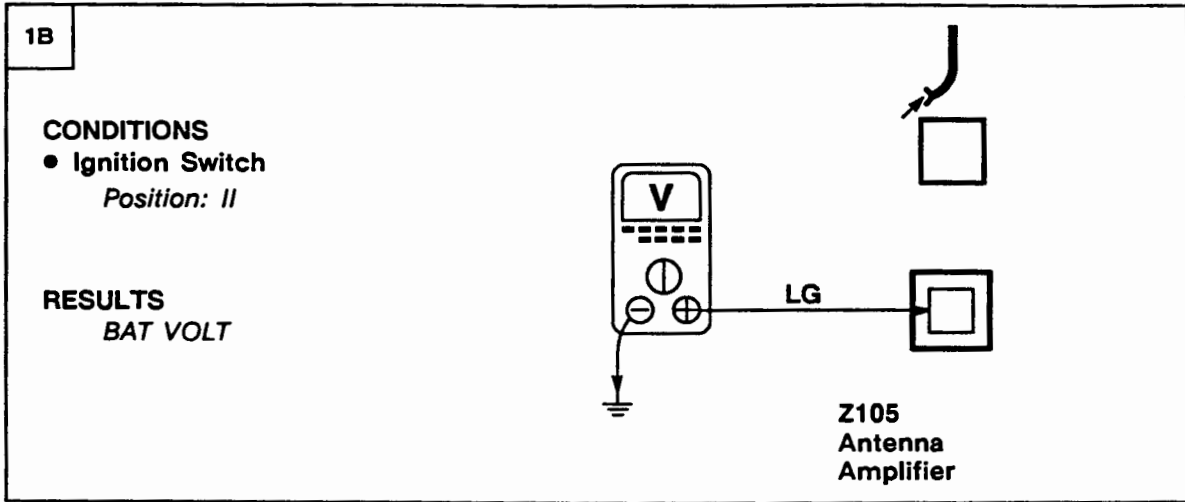

**PROBLEM CAUSE**  
- LG Wire



**PROBLEM CAUSE**  
- Coaxial Cable  
- Radio  
- Antenna Amplifier

**Test C**

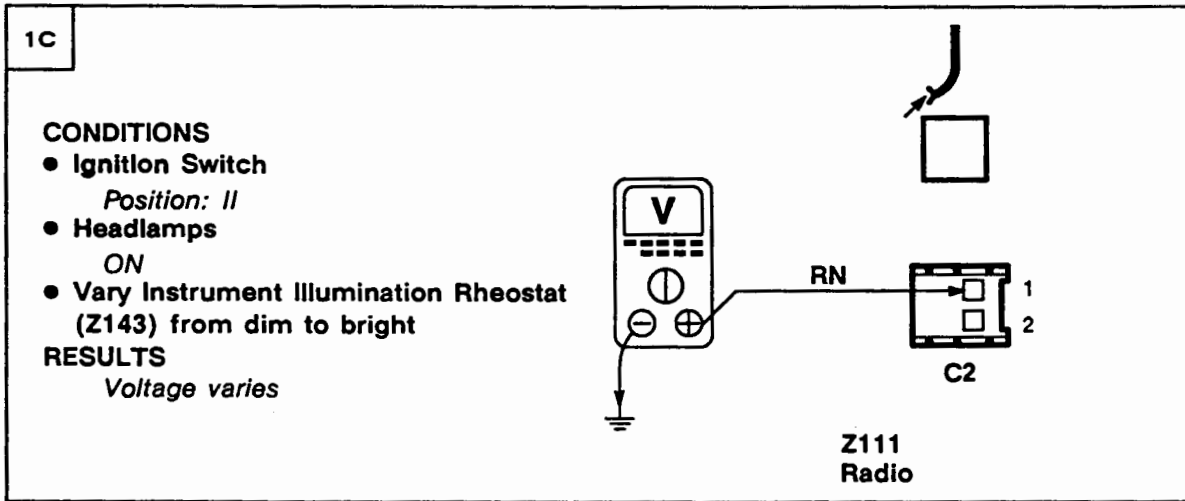

**PROBLEM CAUSE**  
- RN Wire  
- Instrument Illumination Rheostat



**PROBLEM CAUSE**  
- Radio

**Test D**

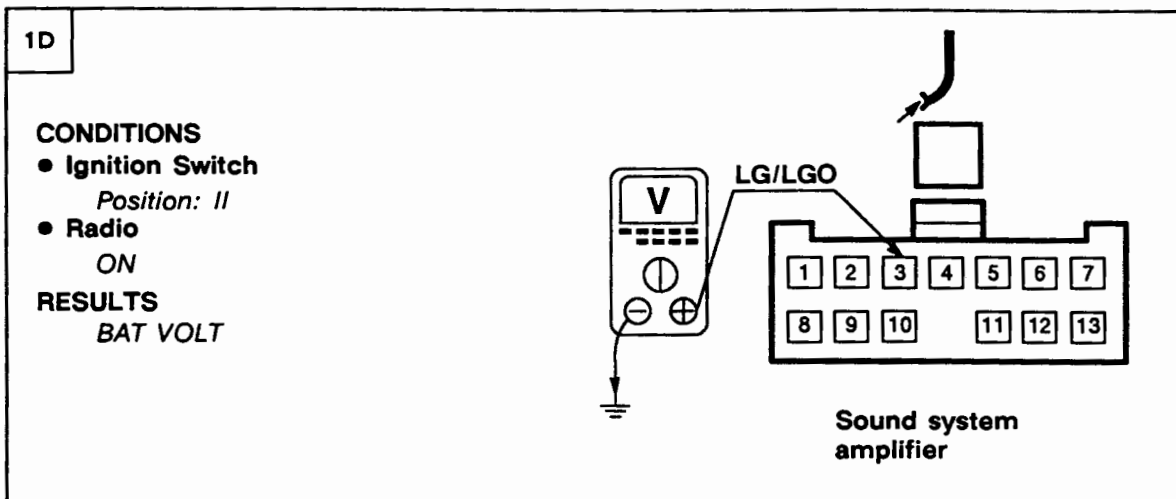

**PROBLEM CAUSE**

- LG Wire
- LGO Wire
- Sound system amplifier fuse

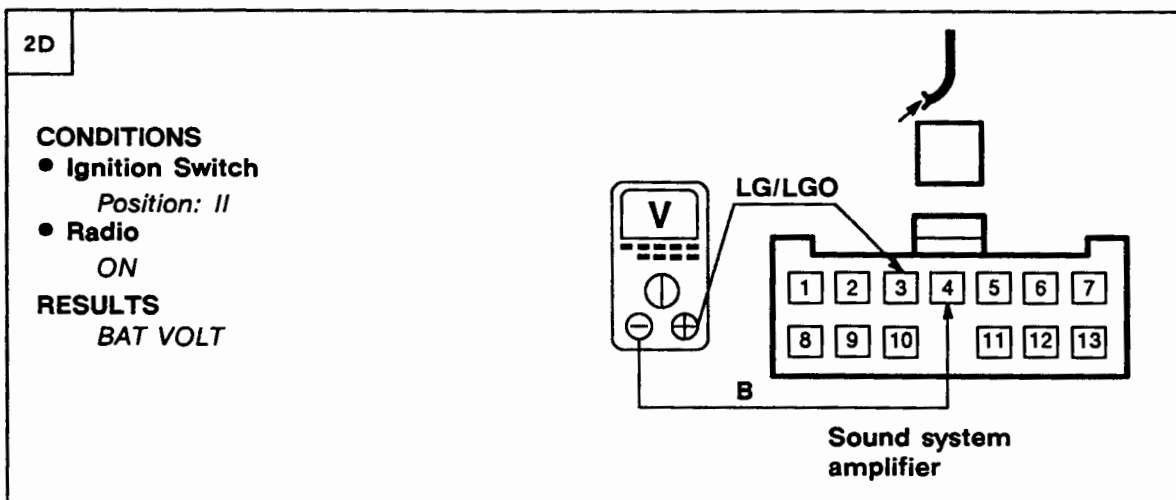

**PROBLEM CAUSE**

- B Wire

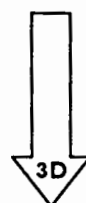

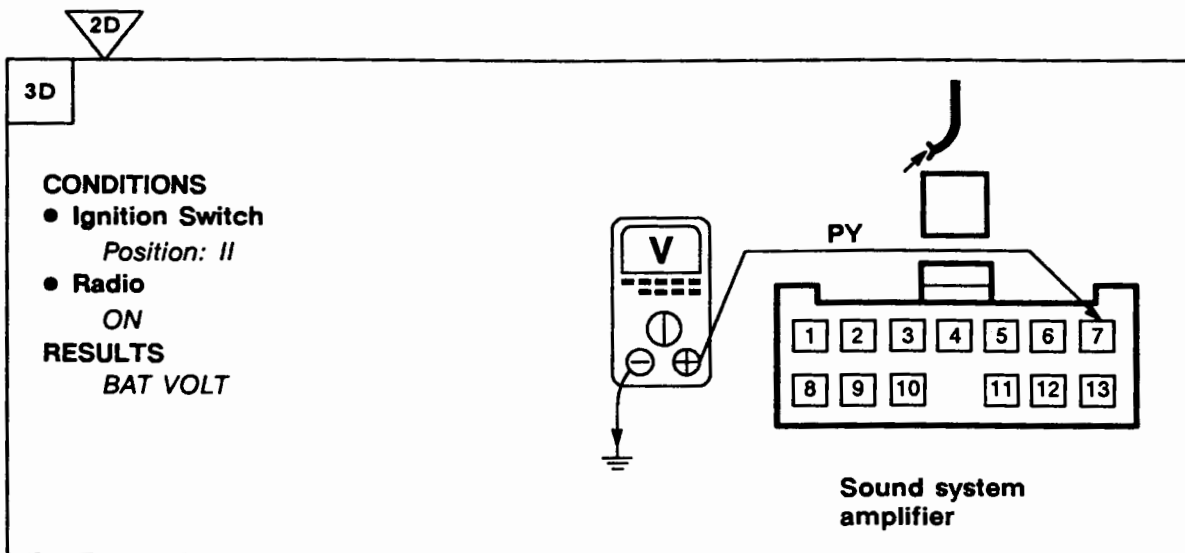

~~OK~~ PROBLEM CAUSE  
- PY Wire

OK

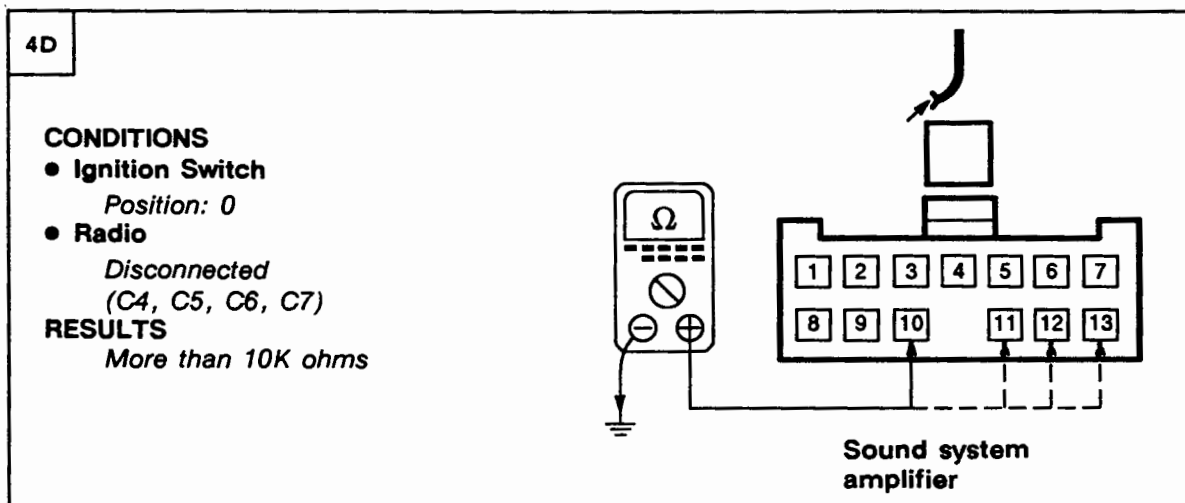

~~OK~~ PROBLEM CAUSE  
- wire (short)

OK



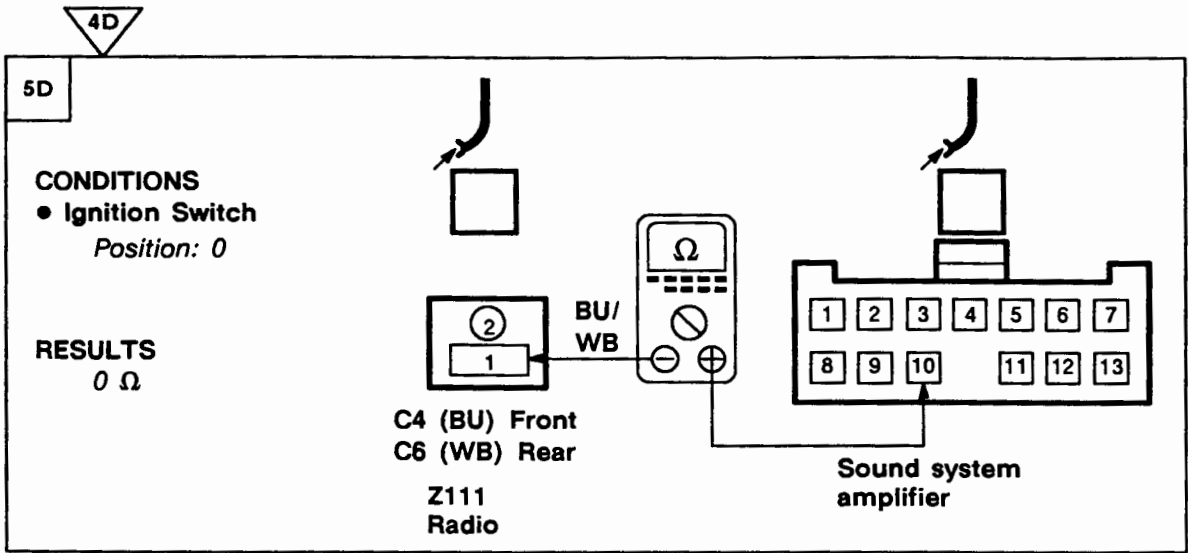

**OK** PROBLEM CAUSE  
 - BU/WB wire (open)

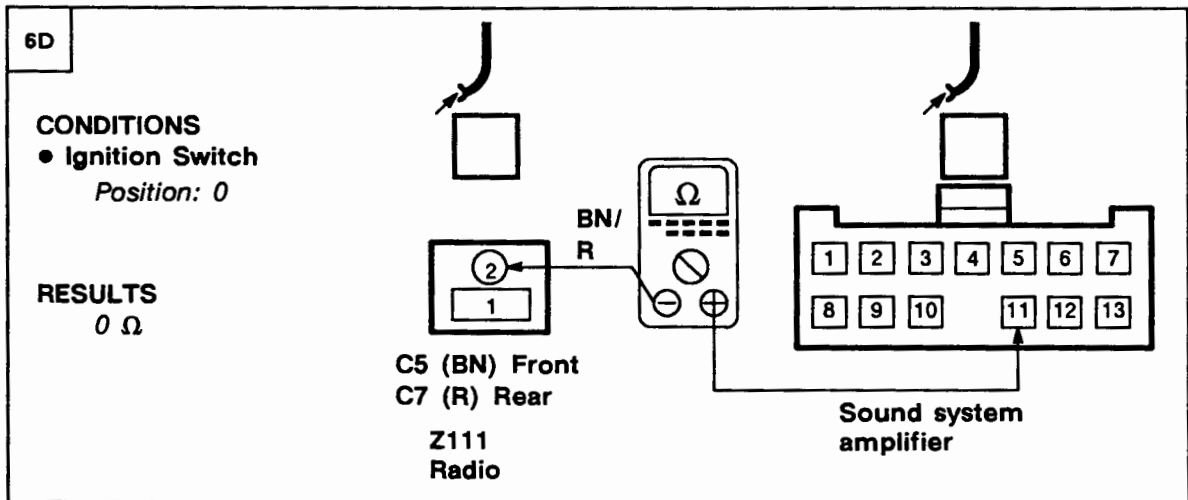
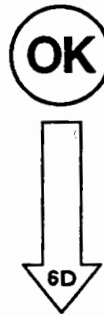

**OK** PROBLEM CAUSE  
 - BN/R wire (open)

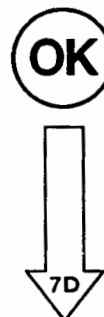

# E7 ETM

## 1992 RANGE ROVER

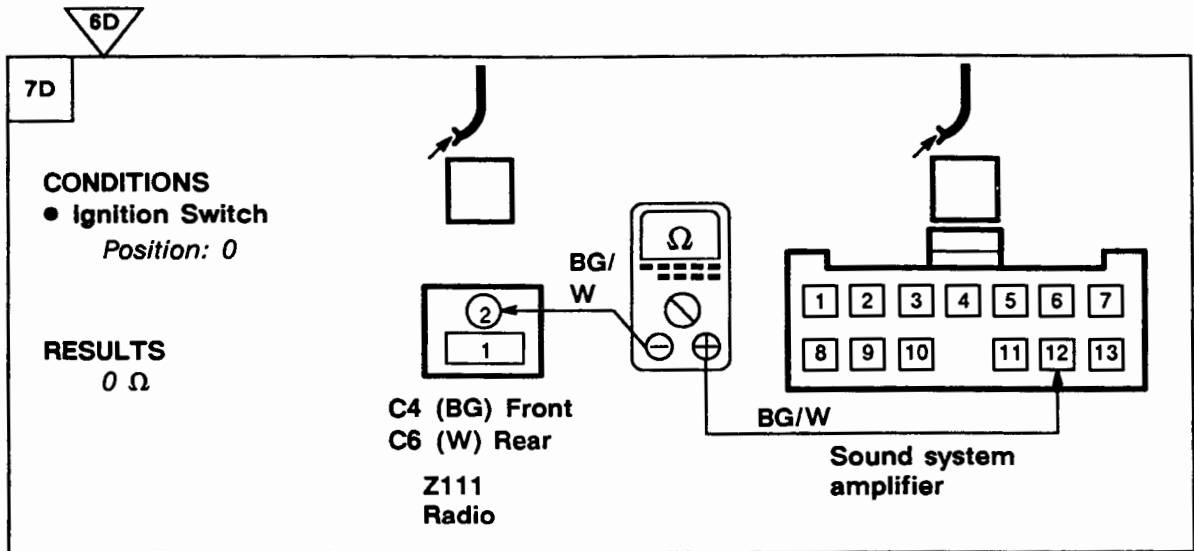

~~OK~~ PROBLEM CAUSE  
 - BG/W wire (open)

OK

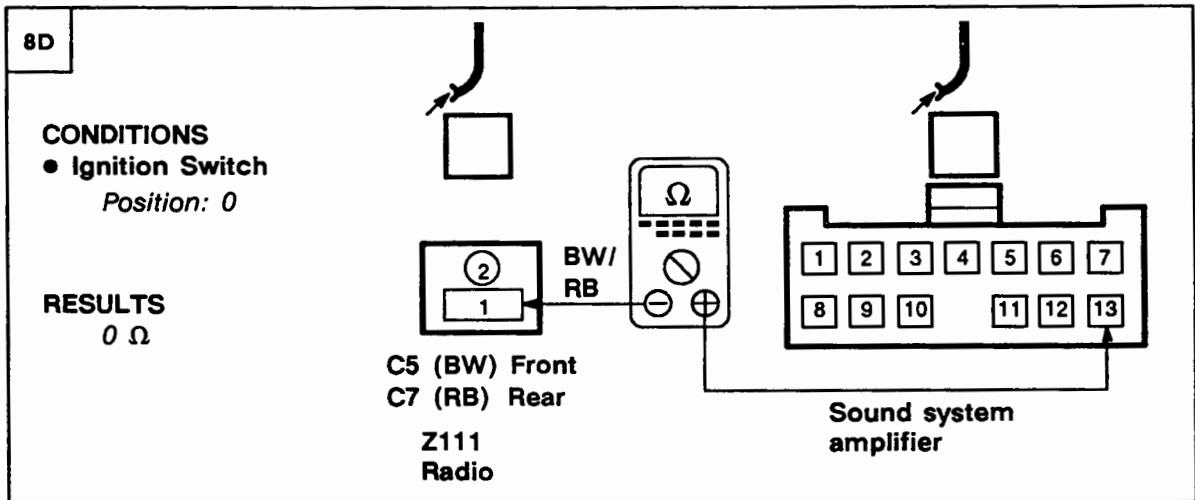
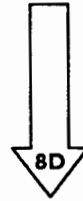

~~OK~~ PROBLEM CAUSE  
 - BW/RB wire (open)

OK





8D

9D

**CONDITIONS**

- Ignition Switch  
*Position: II*
- Install a known good sound system amplifier
- Radio  
*ON*

**RESULTS**

- Speakers  
*Operate*



**PROBLEM CAUSE**

- Speaker
- Speaker wiring
- Crossover (Z157) with Subwoofer (K146)
- Radio



- System OK

**Test E**

1E

**CONDITIONS**

- Ignition Switch  
*Position: 0*

**RESULTS**

*BAT VOLT*



**PROBLEM CAUSE**

- PW Wire
- B Wire



**PROBLEM CAUSE**

- CD Fuse
- Cable
- CD Changer
- Radio

# 1992 RANGE ROVER

## KEY INFORMATION

### CIRCUIT DIAGRAMS

- Circuit diagrams are arranged so that current flow is from the top of the diagram (current source) to the bottom of the diagram (earth).
- Only those components that work together in the circuit are shown. If only part of a component is used in the circuit, then only that part of the component is shown.

#### Remember:

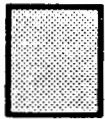

Entire component

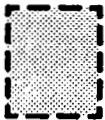

Part of a component

### TERMINAL NUMBER

TERMINAL NUMBER	DESIGNATION
50	Battery voltage: Ignition Switch in position III
30	Battery voltage: supplied constantly
15	Battery voltage: Ignition Switch in position II or III
R	Battery voltage: Ignition Switch in positions I, II
31	Earth

See Introduction (i) for additional circuit diagram symbols.

### DIAGNOSIS

- If the diagram is accompanied by text:
  - Read the Circuit Operation before proceeding with the electrical diagnosis.
  - Read the Troubleshooting Hints before performing the System Diagnosis.
  - Tests follow the System Diagnosis.
  - When performing the System Diagnosis, be certain that all components disconnected in previous steps are reconnected unless otherwise directed.



Component is disconnected.  
Backprobe harness connector



Component is connected.  
Backprobe harness connector

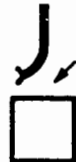

Component is disconnected.  
Probe component



Component is disconnected.  
Probe harness connector



Probe in-line connector

**CIRCUIT OPERATION**

The Clarion CD audio system consists of an AM/FM cassette/CD control head, an Antenna Amplifier (Z105), a 4 channel sound system amplifier, a 6 disc CD Changer (Z114) and 6 speakers. The control head is equipped with an anti-theft feature which makes the unit inoperative once battery power is removed. A 5 digit security code must be entered to restore power to the unit.

Battery voltage is provided to the control head at all times through the PW wire. In addition to monitoring the anti-theft feature, this input keeps the preset station memory alive. Whenever battery power to the unit is lost, the anti-theft code must be entered and the preset stations must be reprogrammed.

When the Radio (Z111) and the ignition are turned on, the voltage signal through the LGK and WO wires to the control head 'wakes up' the unit. The Radio (Z111) plays, the VF display comes on and the control unit buttons illuminate. When the park lamps or headlamps are turned on, a voltage signal is sent through the RB wire to dim the VF display and control buttons for night driving.

Radio (Z111) signals are received via a coaxial cable from the rear screen and Antenna Amplifier (Z105). The amplifier filters and boosts the signal from the rear screen. The amplifier also contains compensating circuitry which cleans up higher frequencies when the heated rear screen is operating.

Power is available to the CD Changer (Z114) at all times. It is operated from the control head when 'CD' is selected by pressing the BAND button. The control head communicates with the Changer via a DIN cable.

Power is available to the 4 channel sound system amplifier at all times. It becomes enabled when the Radio (Z111) is turned on, sending a voltage signal through the UW wire.

# E8 ETM

## 1992 RANGE ROVER

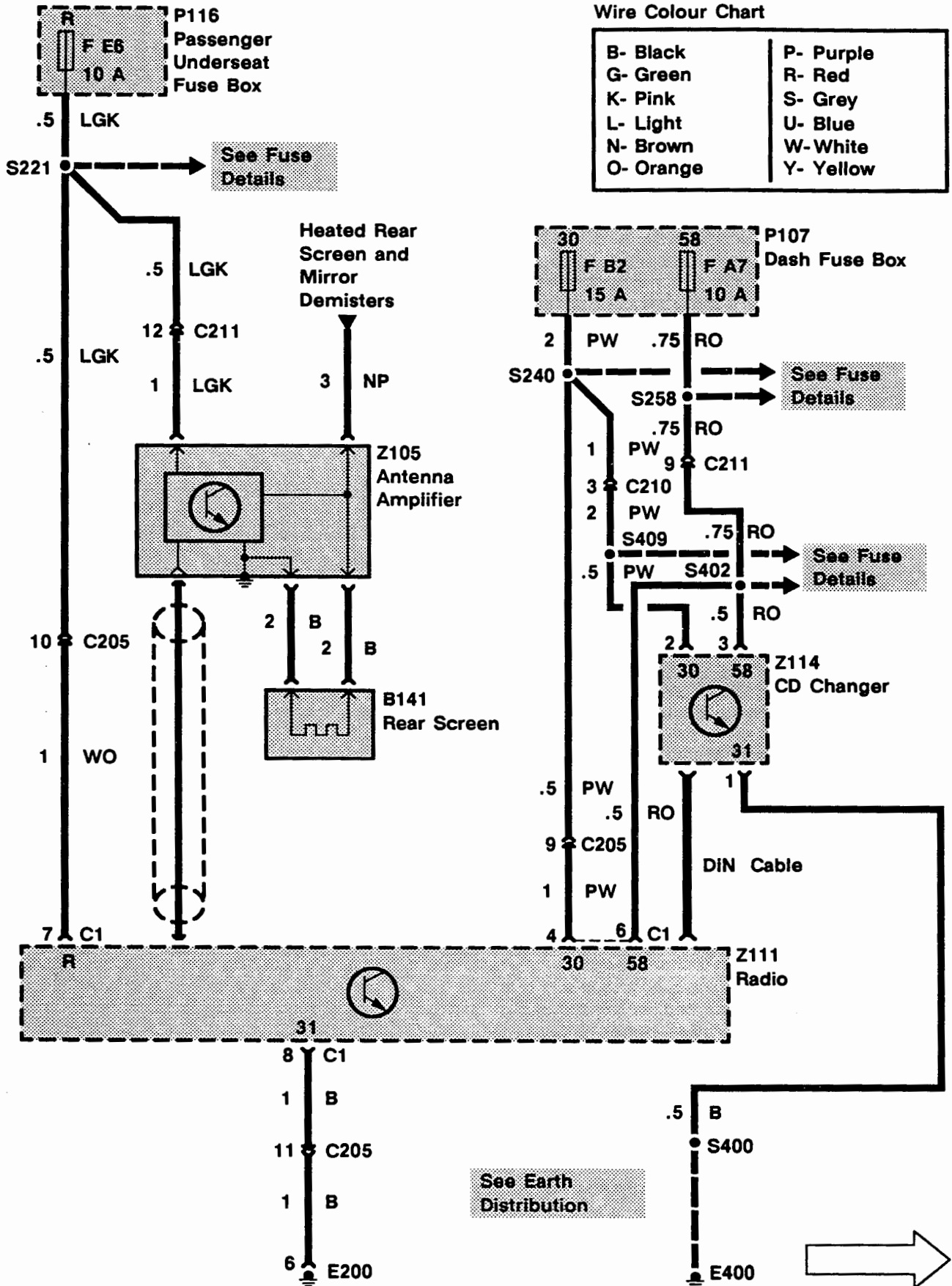

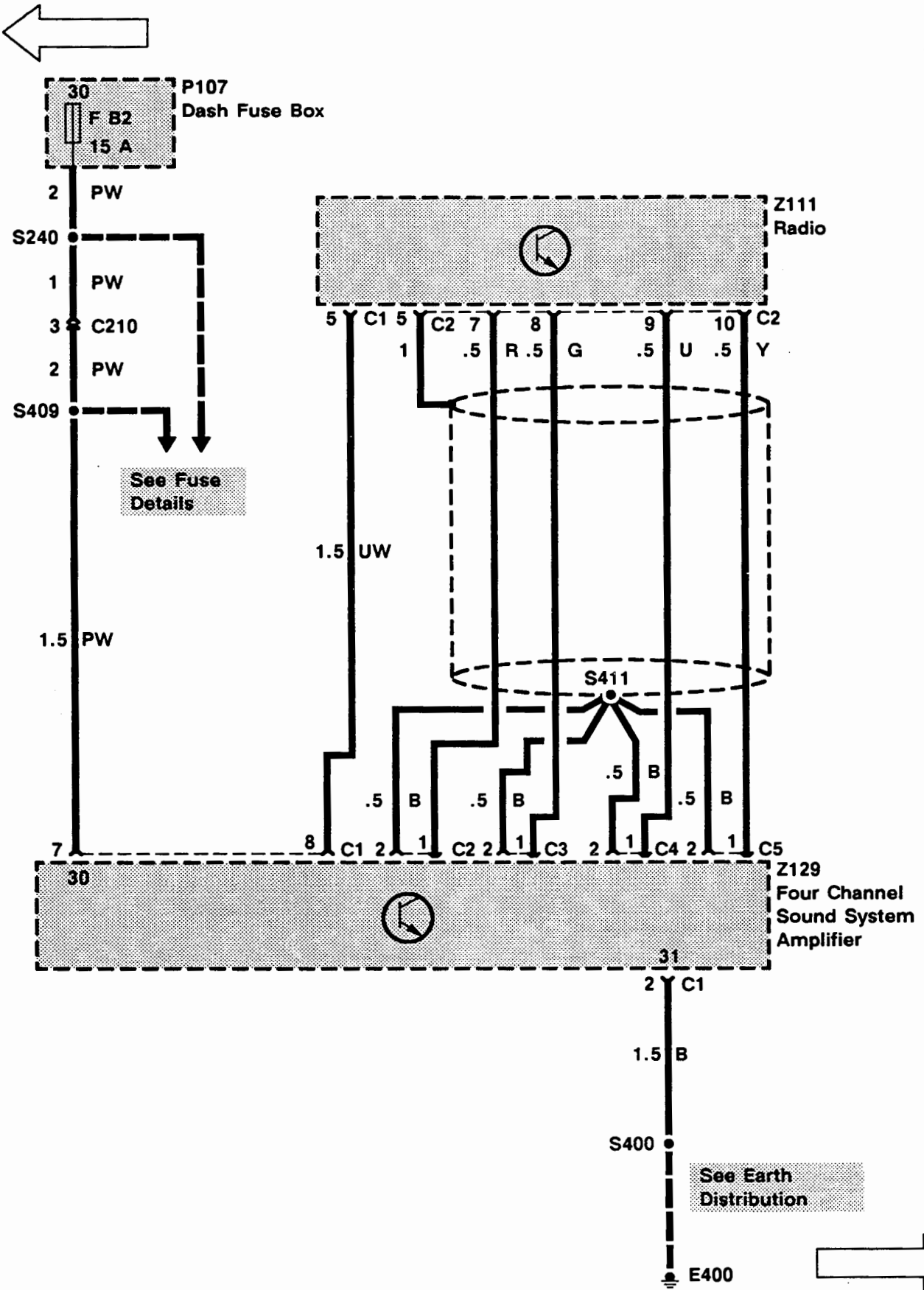

Z129  
Four Channel  
Sound System

Wire Colour Chart

B- Black	P- Purple
G- Green	R- Red
K- Pink	S- Grey
L- Light	U- Blue
N- Brown	W- White
O- Orange	Y- Yellow

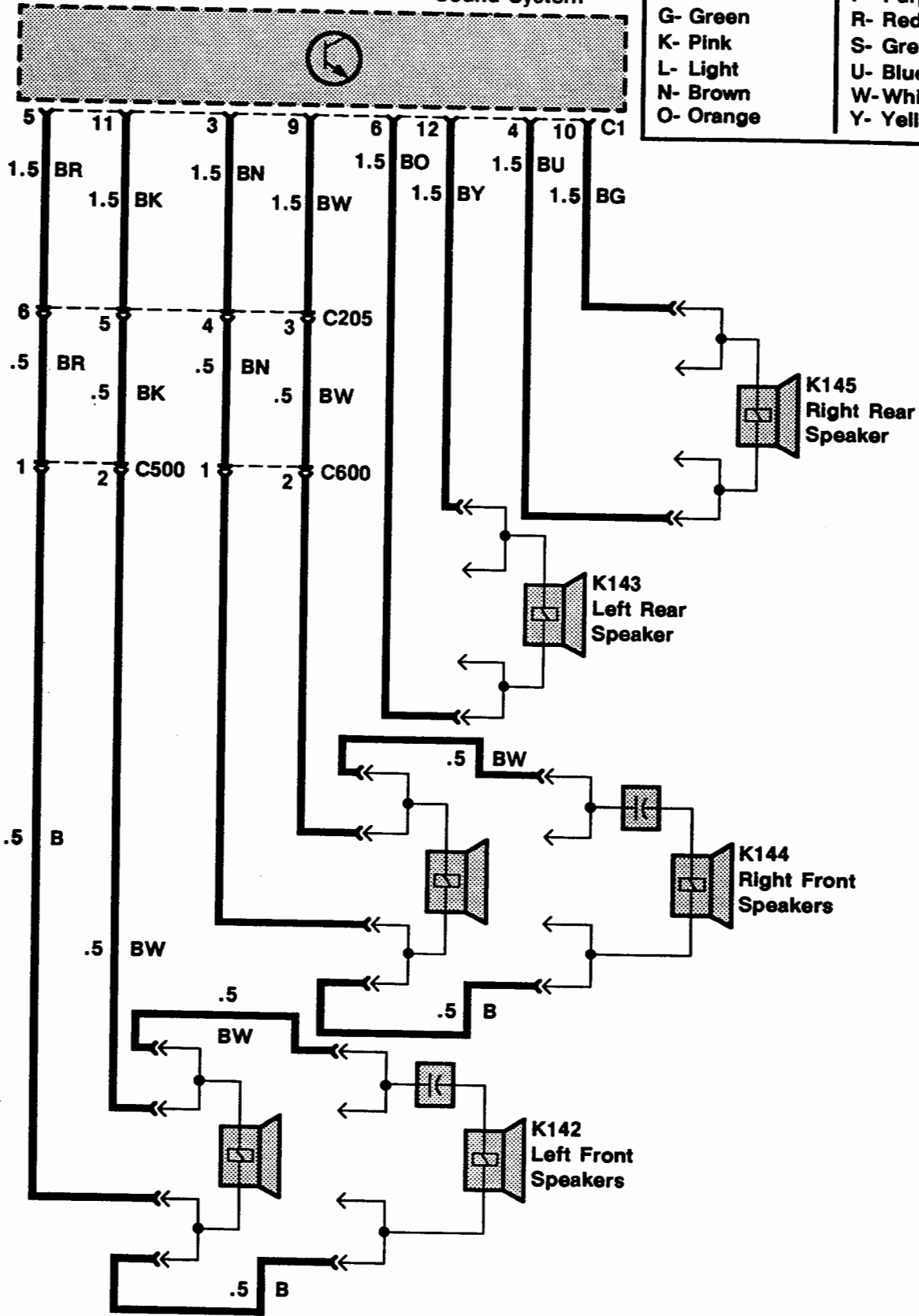

**TROUBLESHOOTING HINTS**

1. Check fuses F B2 and F E6.
2. Check that Radio (Z111) connectors and coaxial cable are tight and properly connected.
3. For proper Radio (Z111) noise diagnosis, take the vehicle outside where signals are strong. Close the hood and keep away from metal buildings or other sources of Radio interference.
4. If Radio (Z111) noise is excessive when an accessory is on, install a Radio noise suppression capacitor to the power lead of that accessory.
5. If Radio (Z111) noise is excessive at all times, check antenna wiring. If OK, check spark plugs (P118), spark plug wiring and wiring close to the ignition system which could transmit noise to the Radio wiring.
6. If the Radio (Z111) is inoperative and 'code' is being shown on the display, follow the instructions below.

**Security Code Instructions**

1. Obtain 5-digit security code from vehicle owner or manufacturer.
2. Enter the code number using the Radio (Z111) push-button selectors.

NOTE: If the correct code is not entered in 3 successive attempts, the Radio (Z111) will not accept another entry until the Radio has been left on for 1 hour with the ignition on.

NOTE: When entering the code, be sure to complete the sequence numbering of that 5-digit code even if you made a mistake. For example, if the correct code number sequence is 43215 and you mistakenly enter 42 instead of 43, continue the code number sequence of 215 to complete that entry. A 'beep' will sound, 'code' will still be displayed and the Radio will not operate. Re-enter the correct code 43215 and the Radio will operate.

NOTE: If an audible 'beep' is heard while entering the code, STOP immediately. Begin entering the code again, starting with the first number of the 5-digit code.

NOTE: If a push-button is touched accidentally when the ignition is off, a warning tone will

sound. Turn the ignition on and the tone will stop.

**SYSTEM DIAGNOSIS**

1. If Radio (Z111) does not operate at all, do Test A.
2. If Radio (Z111) scans past all frequencies when in seek mode and hiss is present over most stations, do Test B. (Test B assumes that the heated rear screen operates. If it does not, troubleshoot that system first.)
3. If VF display does not dim when headlamps or park lamps are turned on, do Test C.
4. If 1 or more (but not all) speakers do not operate, do Test D.
5. If only the CD Changer (Z114) does not operate, do Test E.

THIS PAGE HAS BEEN INTENTIONALLY LEFT BLANK



Test A

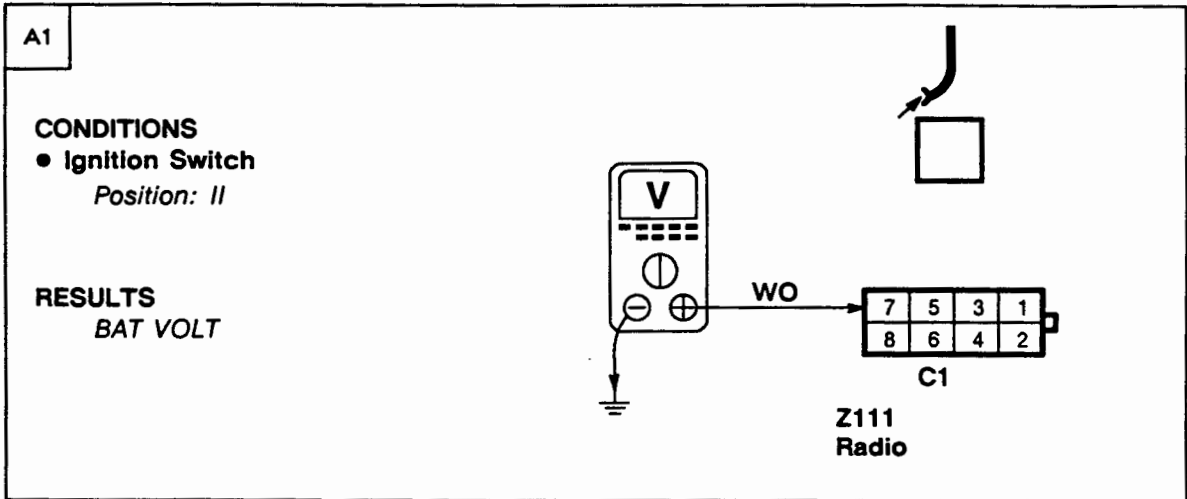

~~OK~~ PROBLEM CAUSE

- WO Wire
- LGK Wire

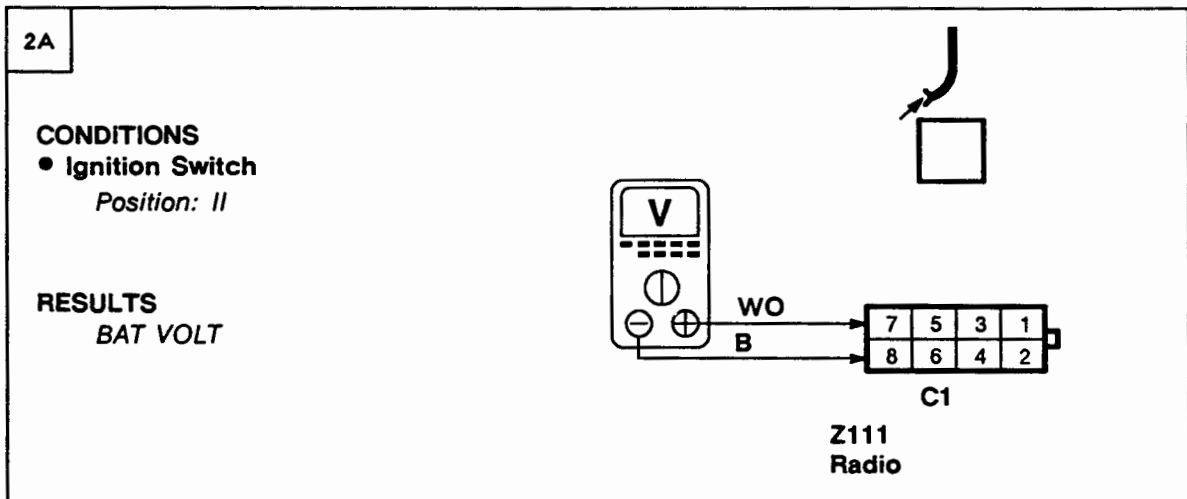

~~OK~~ PROBLEM CAUSE

- B Wire

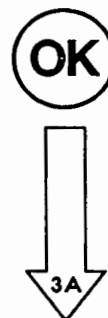

**E8 ETM**

**1992 RANGE ROVER**

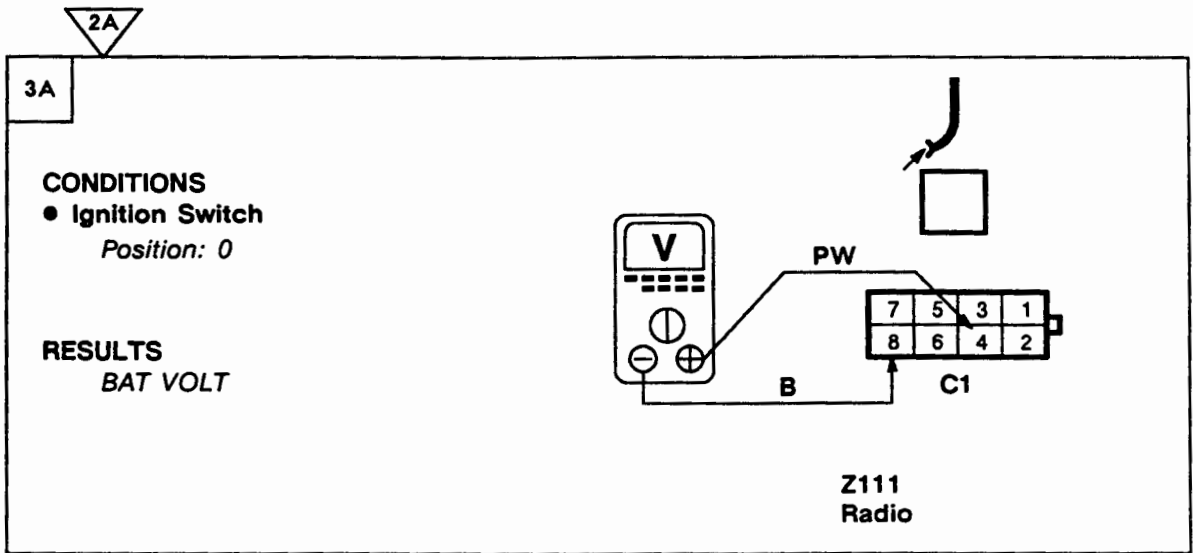

~~OK~~ PROBLEM CAUSE  
- PW Wire

OK

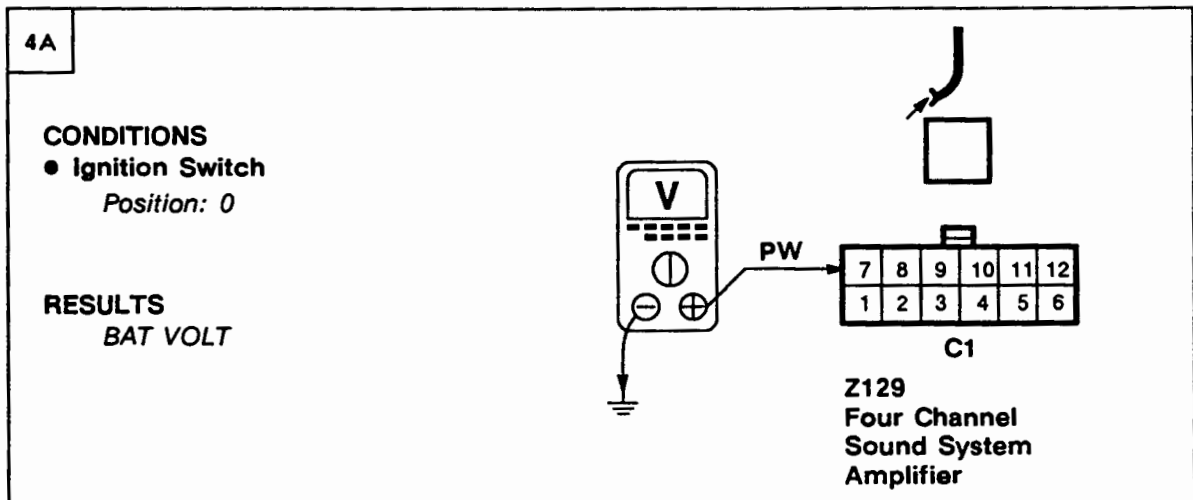
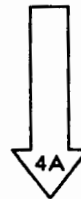

~~OK~~ PROBLEM CAUSE  
- PW Wire

OK

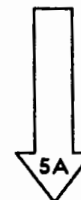

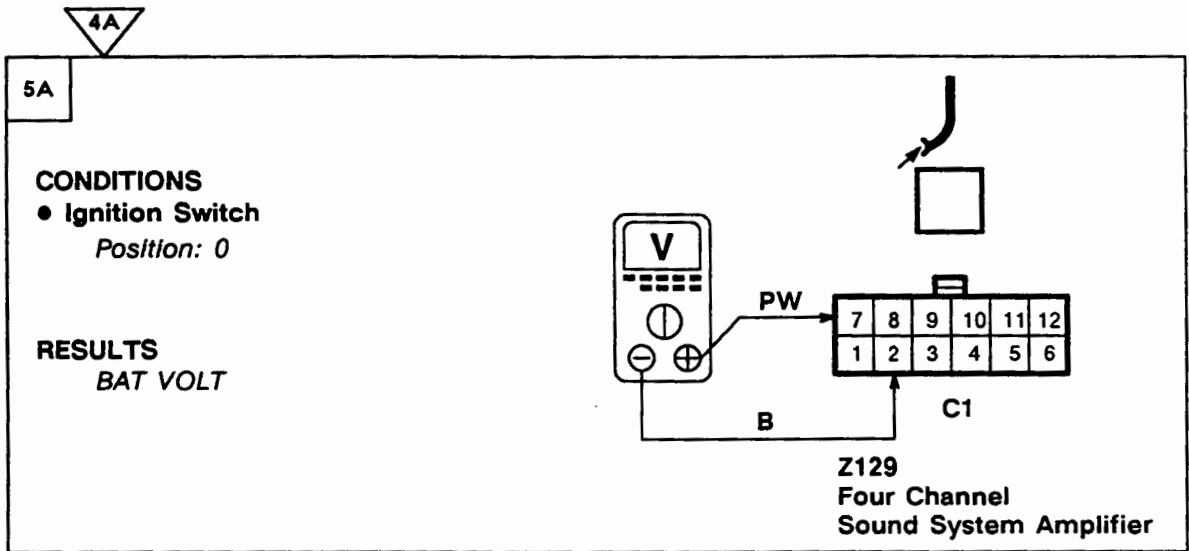

~~OK~~ PROBLEM CAUSE  
- B Wire

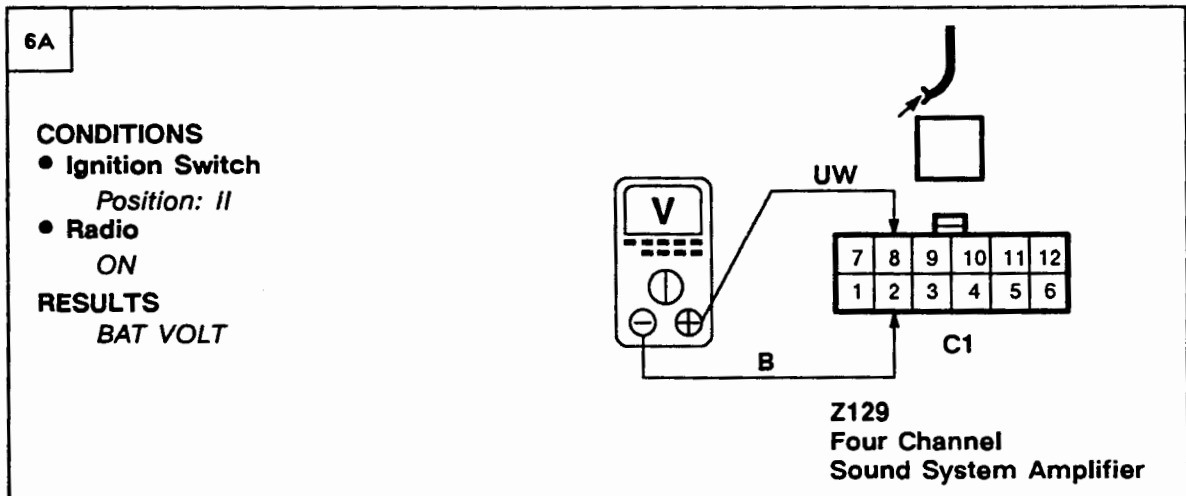
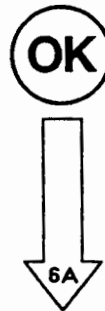

~~OK~~ PROBLEM CAUSE  
- UW Wire  
- Radio

OK PROBLEM CAUSE  
- Four Channel Sound  
System Amplifier

**Test B**

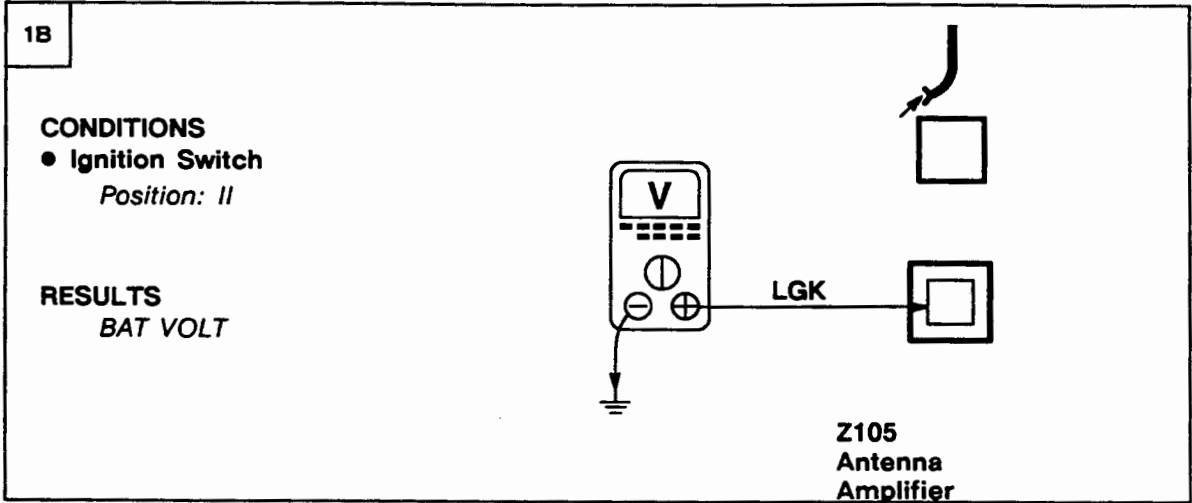

**PROBLEM CAUSE**  
- LGK Wire



**PROBLEM CAUSE**  
- Coaxial Cable  
- Radio  
- Antenna Amplifier

**Test C**

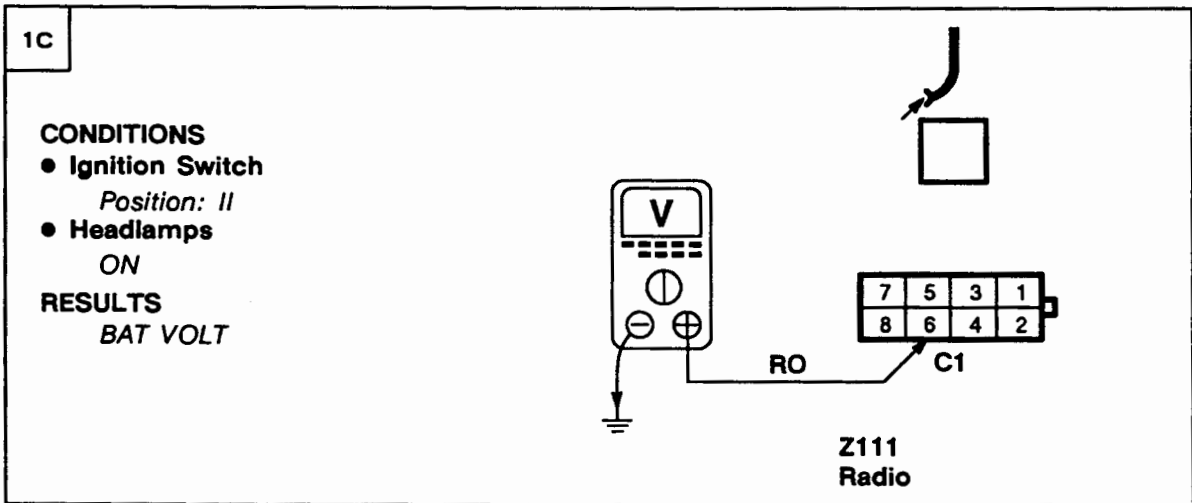

**PROBLEM CAUSE**  
- RO Wire  
- F A3 Fuse



**PROBLEM CAUSE**  
- Radio

Test D

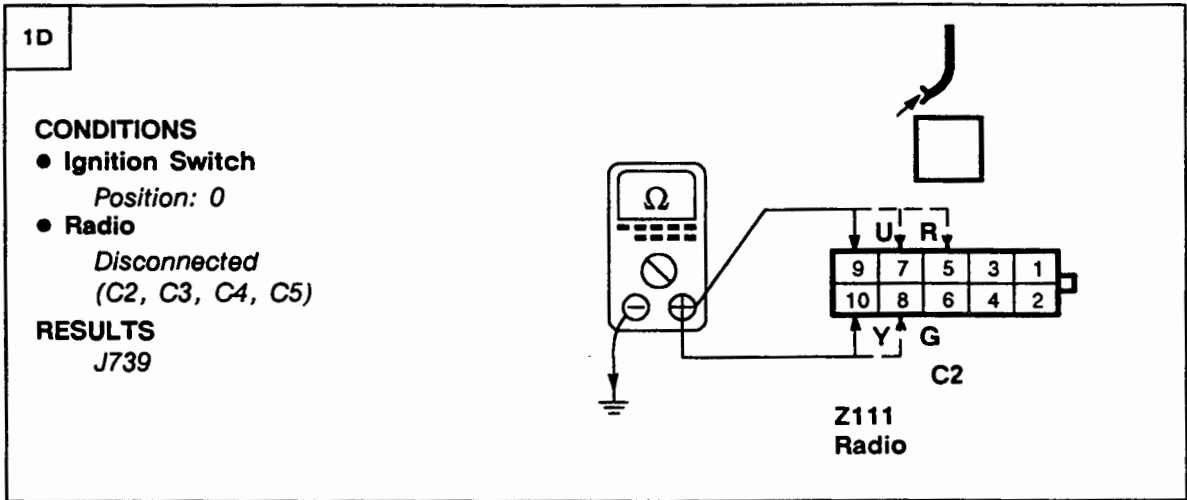

~~OK~~ PROBLEM CAUSE  
- wire (short)

OK

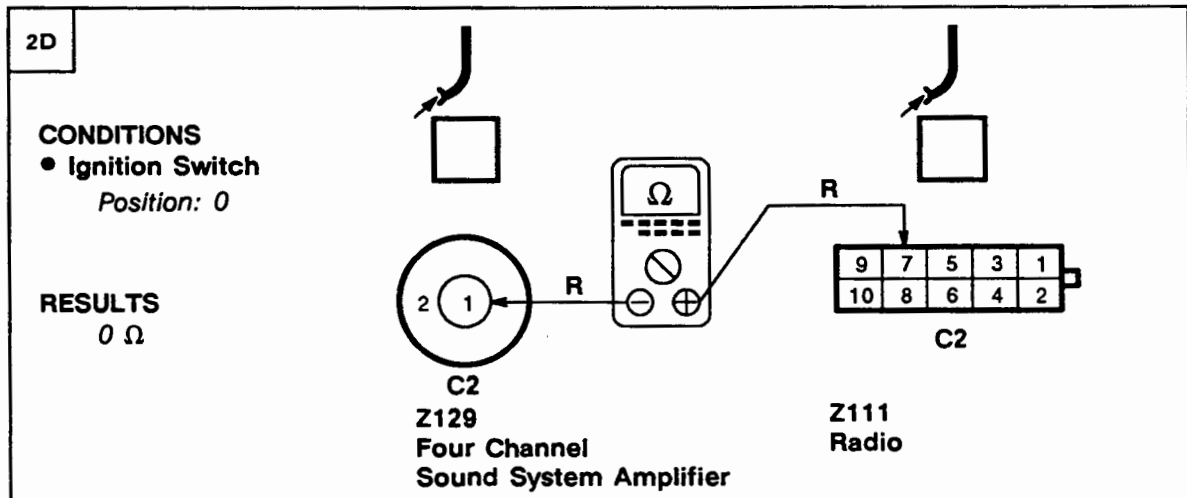

~~OK~~ PROBLEM CAUSE  
- R wire (open)

OK



**E8 ETM**

**1992 RANGE ROVER**

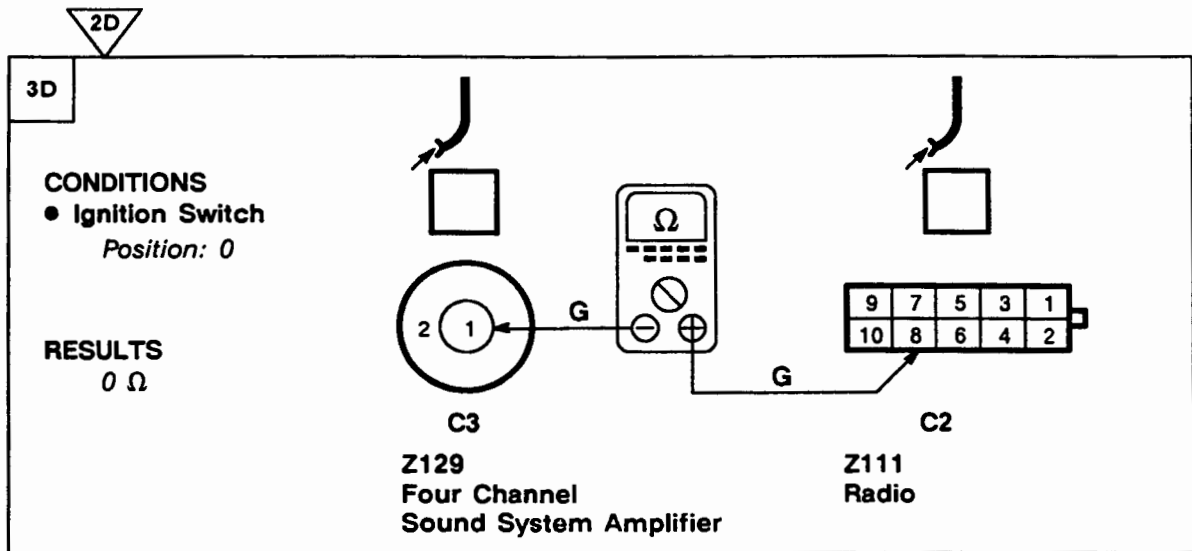

**PROBLEM CAUSE**  
- G wire (open)

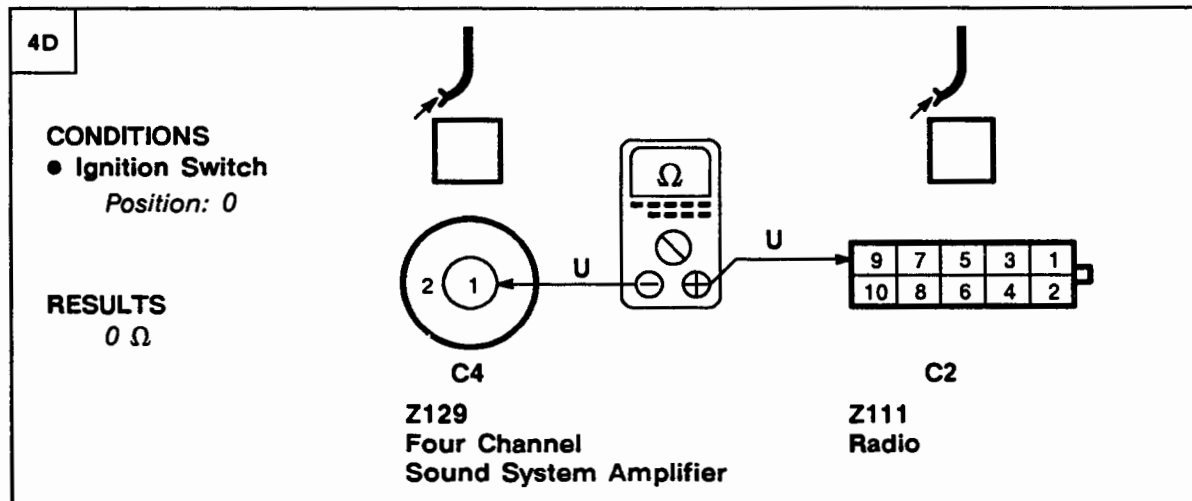
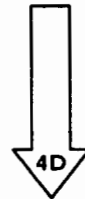

**PROBLEM CAUSE**  
- U wire (open)



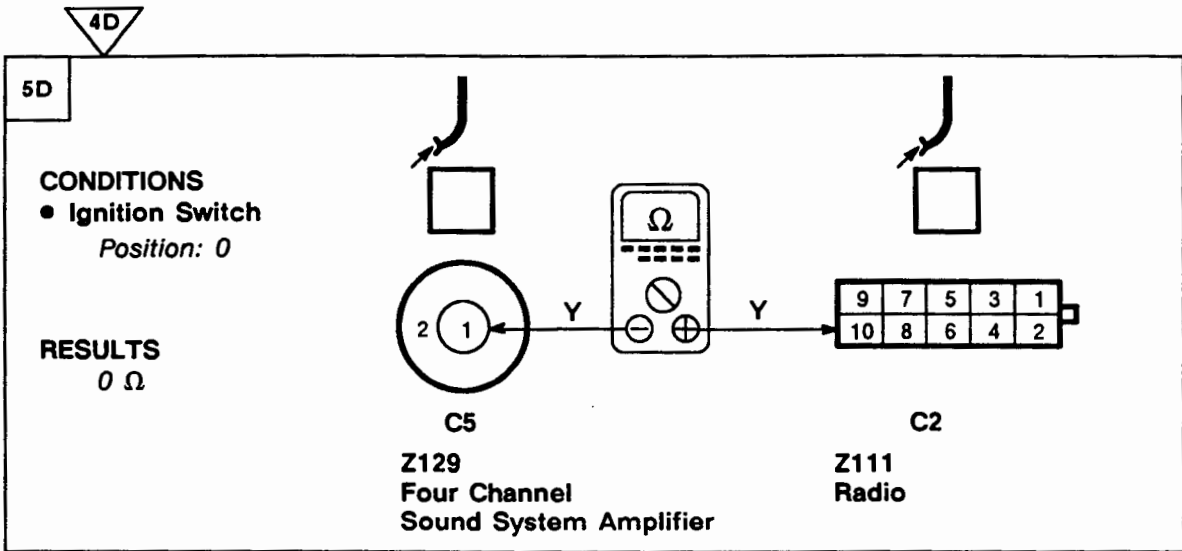

**PROBLEM CAUSE**  
- Y wire (open)

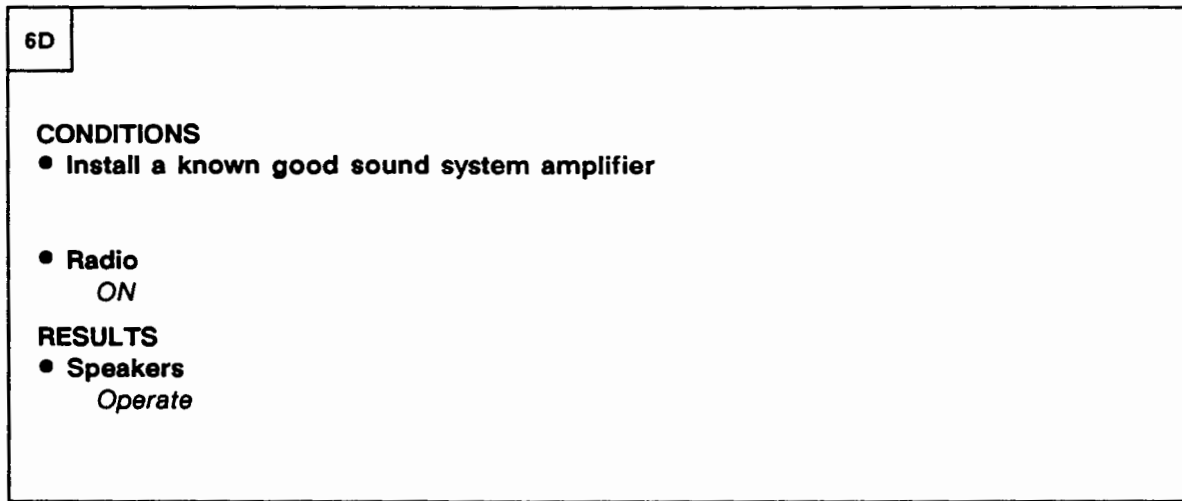

**PROBLEM CAUSE**  
- Speaker  
- Speaker wiring  
- Radio



**SYSTEM OK**



**E8 ETM**

1992 RANGE ROVER

Test E

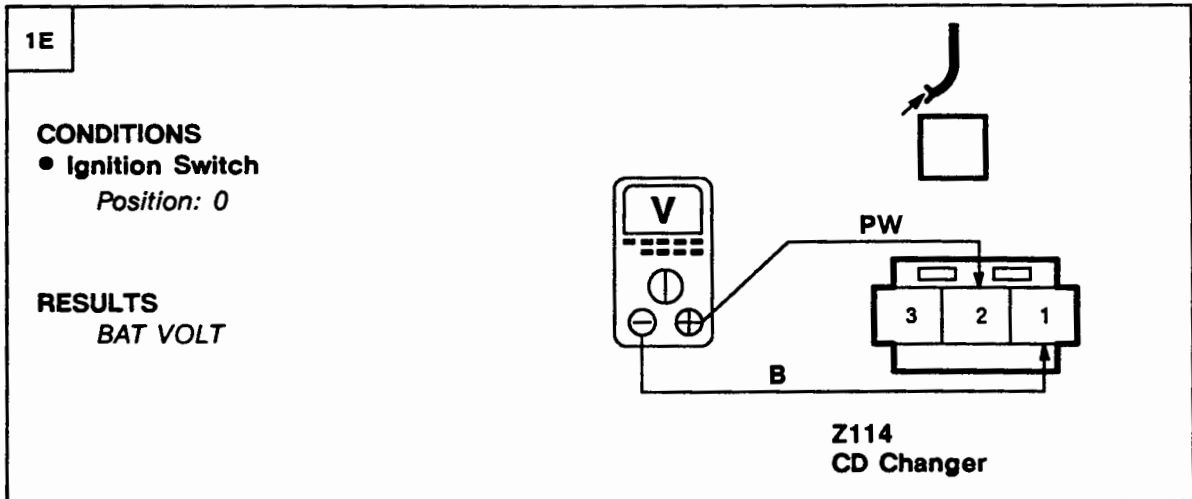

- PROBLEM CAUSE**
- PW Wire
  - B Wire



- PROBLEM CAUSE**
- CD Fuse
  - Cable
  - CD Changer
  - Radio