

Wire Colour Chart

B- Black	P- Purple
G- Green	R- Red
K- Pink	S- Grey
L- Light	U- Blue
N- Brown	W- White
O- Orange	Y- Yellow

F1 ETM

1992 RANGE ROVER

Wire Colour Chart

B- Black	P- Purple
G- Green	R- Red
K- Pink	S- Grey
L- Light	U- Blue
N- Brown	W- White
O- Orange	Y- Yellow

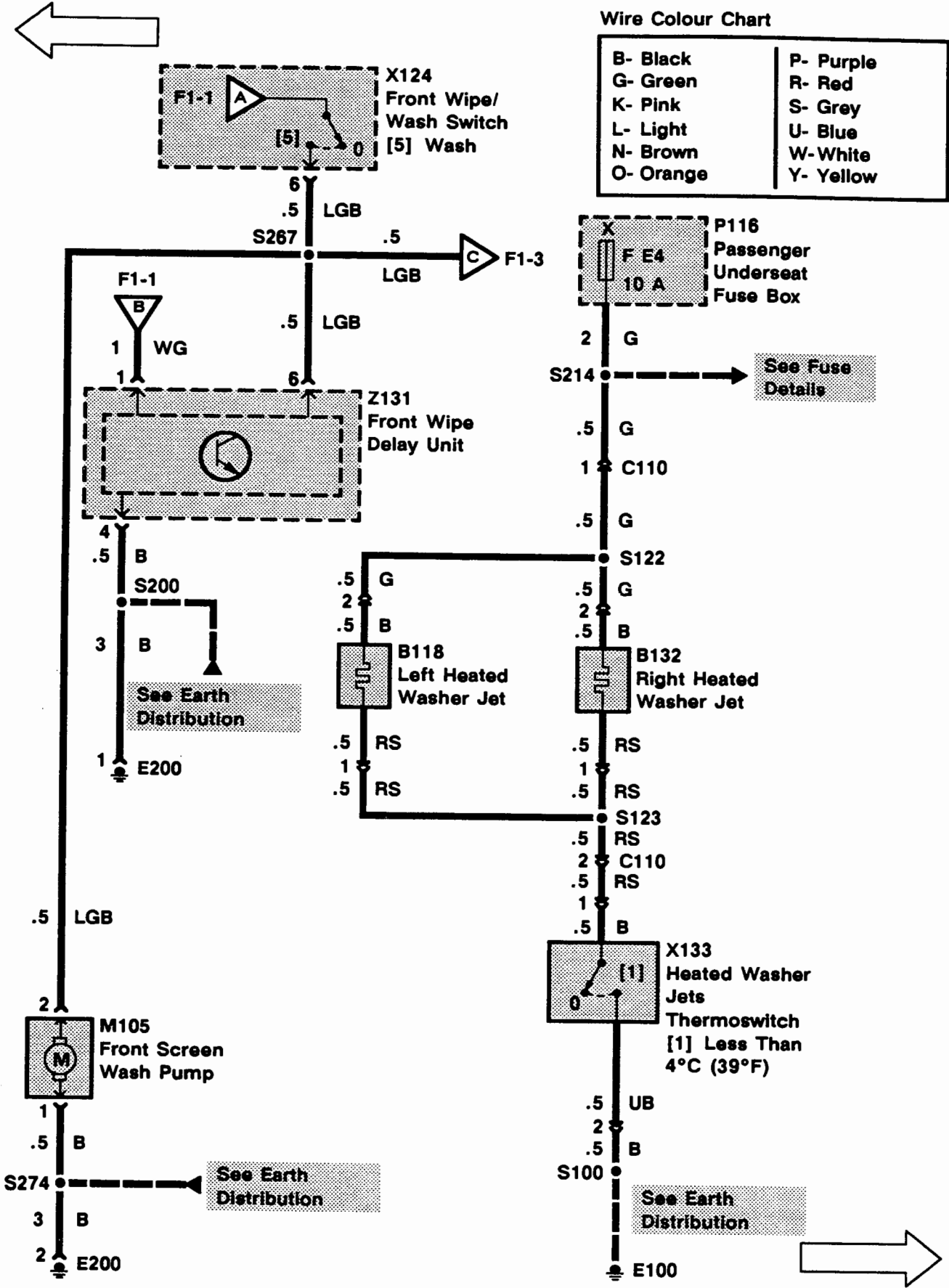

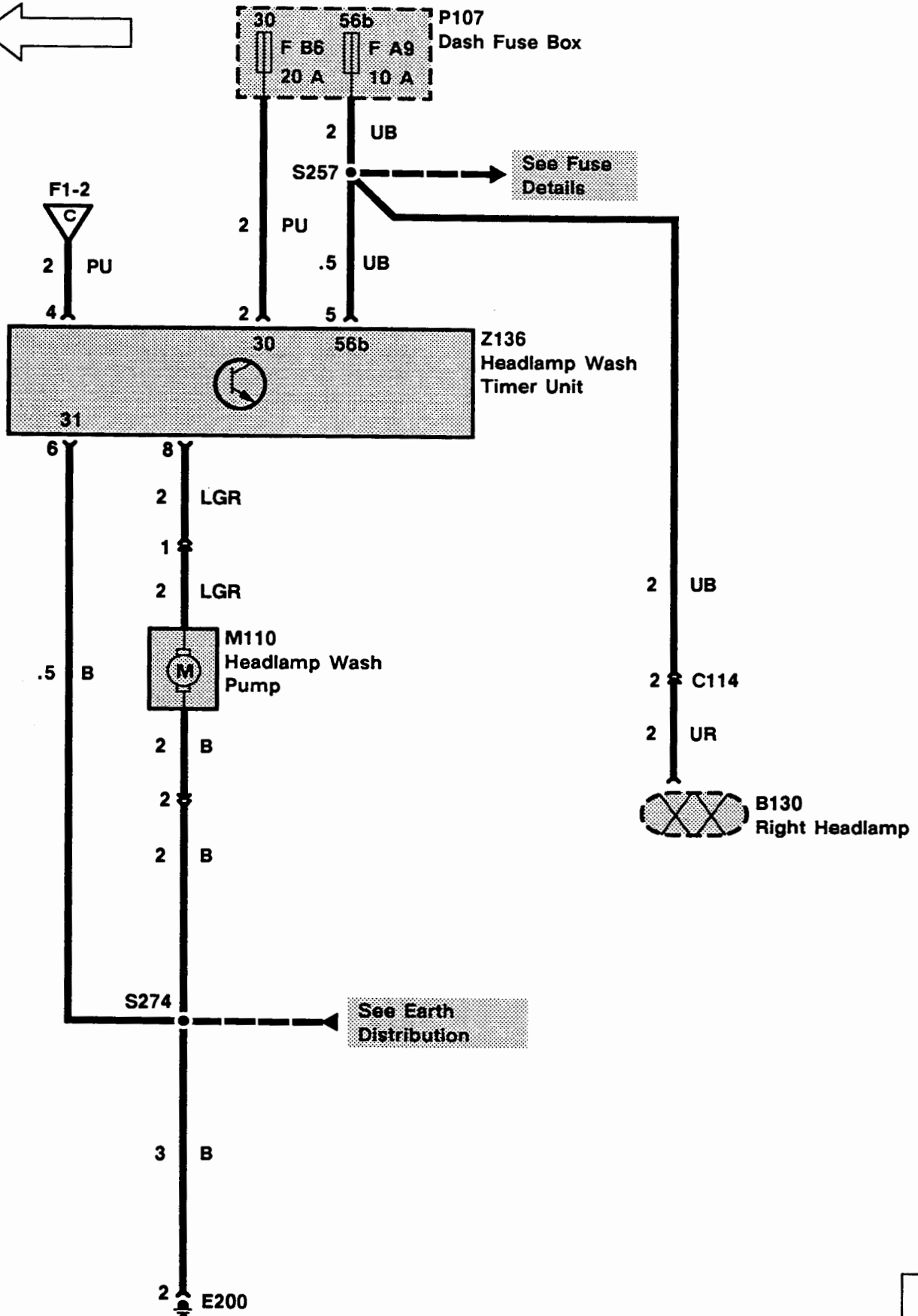
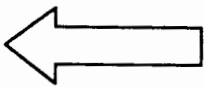

See Fuse Details

See Earth Distribution

1992 RANGE ROVER

KEY INFORMATION

CIRCUIT DIAGRAMS

- Circuit diagrams are arranged so that current flow is from the top of the diagram (current source) to the bottom of the diagram (earth).
- Only those components that work together in the circuit are shown. If only part of a component is used in the circuit, then only that part of the component is shown.

● Remember:

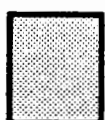

Entire component

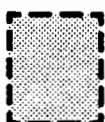

Part of a component

TERMINAL NUMBER

DESIGNATION

50	Battery voltage: Ignition Switch in position III
30	Battery voltage: supplied constantly
15	Battery voltage: Ignition Switch in position II or III
R	Battery voltage: Ignition Switch in positions I, II
31	Earth

See Introduction (i) for additional circuit diagram symbols.

DIAGNOSIS

- If the diagram is accompanied by text:
 - Read the Circuit Operation before proceeding with the electrical diagnosis.
 - Read the Troubleshooting Hints before performing the System Diagnosis.
 - Tests follow the System Diagnosis.
 - When performing the System Diagnosis, be certain that all components disconnected in previous steps are reconnected unless otherwise directed.



Component is disconnected.
Backprobe harness connector



Component is connected.
Backprobe harness connector



Component is disconnected.
Probe component



Component is disconnected.
Probe harness connector



Probe in-line connector

CIRCUIT OPERATION**Washer**

The Rear Screen Washer Pump (M119) motor is earthed at all times. The motor runs when battery voltage is applied to the motor through the Rear Wipe/Wash Switch (X155) when the switch is held in the WASH position.

Wiper

When the Rear Wipe/Wash Switch (X155) is pulled momentarily to the WIPE position, the Rear Wipe Delay Unit (Z154) applies battery voltage to the Rear Wiper Motor (M120). The motor leaves the PARK position and receives battery power from the 'ignition on' wire. The wiper then makes 2 sweeps across the rear screen every 10 seconds. When the switch is pulled momentarily to WIPE, the wiper makes 1 sweep across the rear screen and then stops when the motor's internal cam switch moves to the PARK position.

When the washer is requested, battery voltage is applied to the Rear Wipe Delay Unit (Z154). The unit applies battery voltage to the Rear Wiper Motor (M120) as described above. The motor runs as long as the switch is held in WASH or for a few sweeps across the screen. If the tailgate is open, the Tailgate Switch (X170) applies earth to the Rear Wipe Delay Unit (Z154), which then removes battery voltage from the Rear Wiper Motor (M120). The wiper will not operate with the interior lamps on, because the wiper inhibit input of the Rear Wipe Delay Unit (Z154) is earthed when the interior lamps are switched on.

F3 ETM

1992 RANGE ROVER

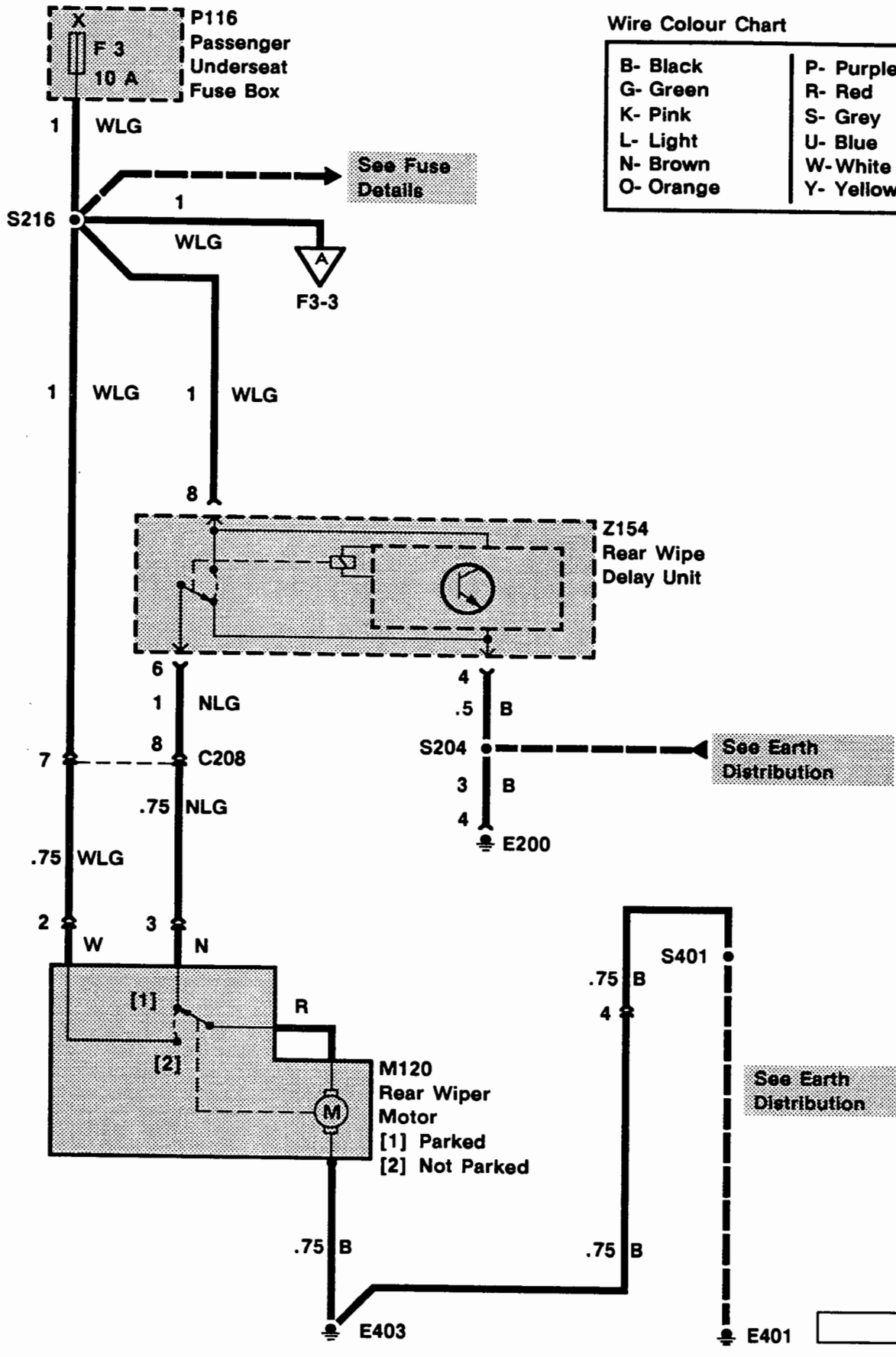

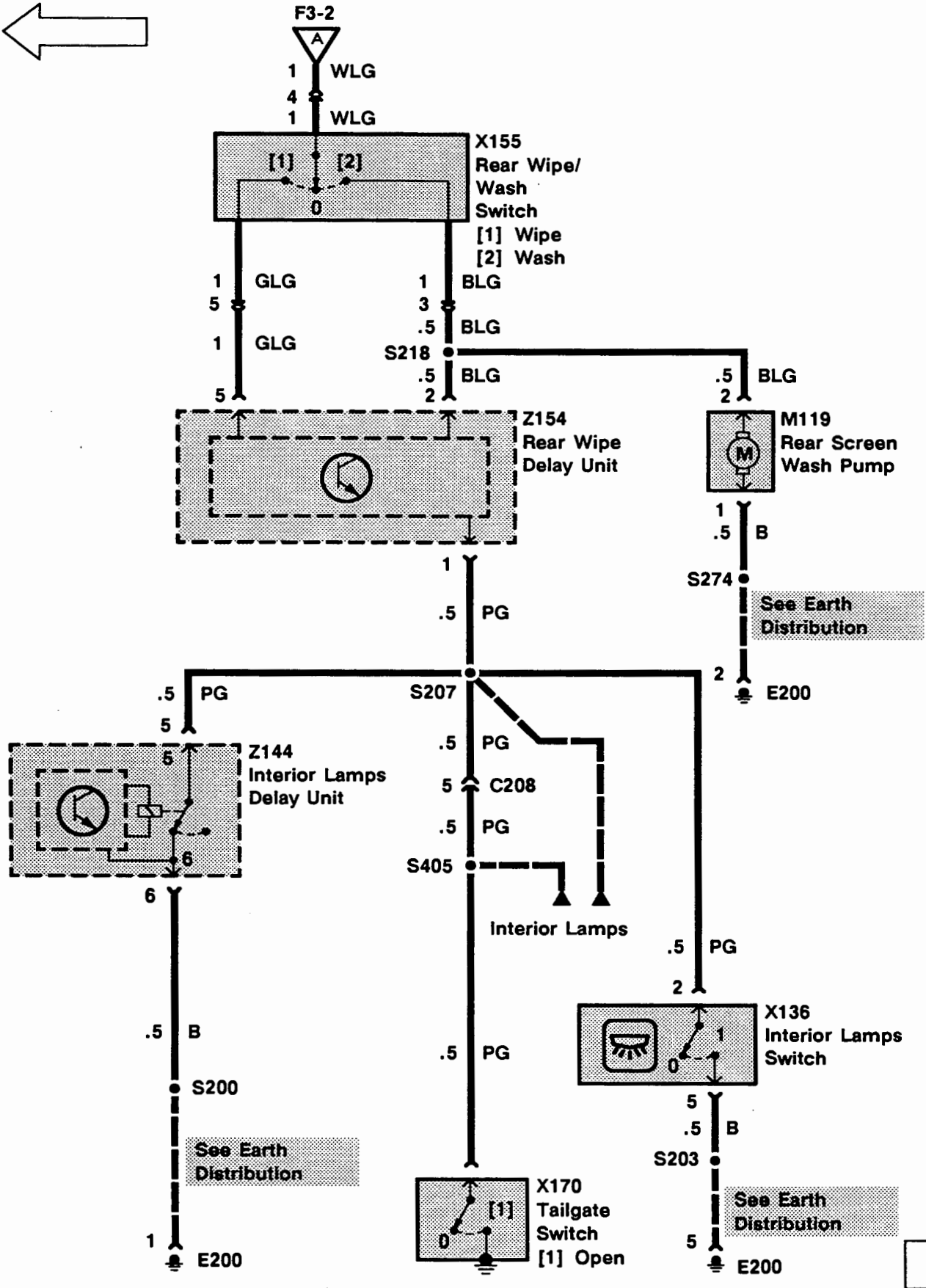
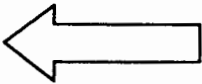

TROUBLESHOOTING HINTS

1. If the washer does not operate, check the washer fluid hoses for kinks or blockage.
2. If the wiper does not operate only when washer is requested, check BLG wire and Rear Wipe Delay Unit (Z154).
3. If the wiper operates with tailgate open and the interior lamps do not light, check Tailgate Switch (X170) and PG wires.
4. If the wiper operates with the tailgate open and the interior lamps operate normally, check PG wire and Rear Wipe Delay Unit (Z154).
5. If the washer runs continuously, replace the Rear Wipe/Wash Switch (X155).

SYSTEM DIAGNOSIS

1. If wiper and washer do not operate, do Test A.
2. If the wiper does not operate but washer is OK, do Test B.
3. If the washer does not operate but wiper is OK, do Test C.
4. If the wiper runs with Rear Wipe/Wash Switch (X155) off, do Test D.

Test A

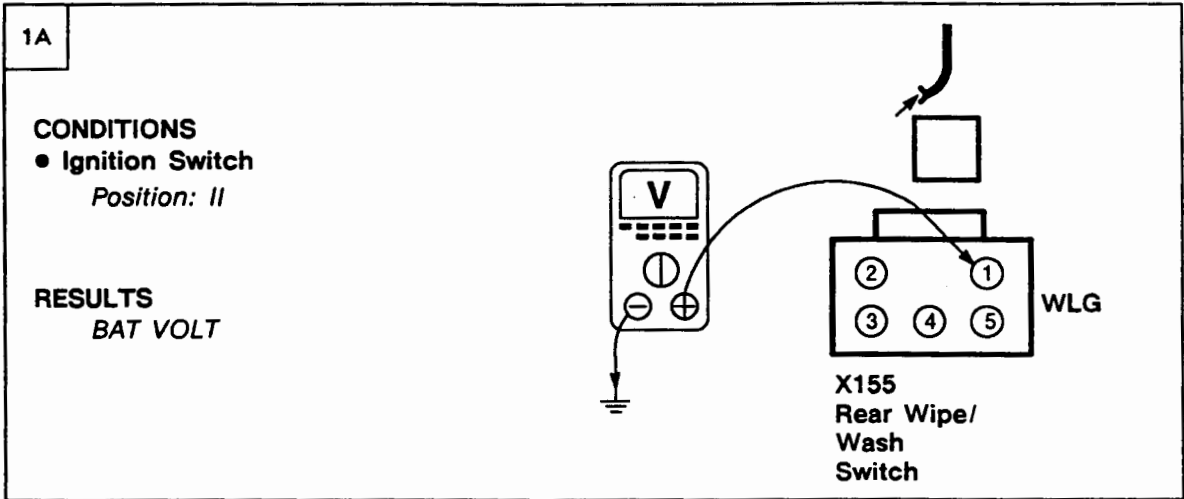

OK PROBLEM CAUSE
- WLG Wire
- F 3 Fuse

OK PROBLEM CAUSE
- Rear Wipe/Wash Switch

Test B

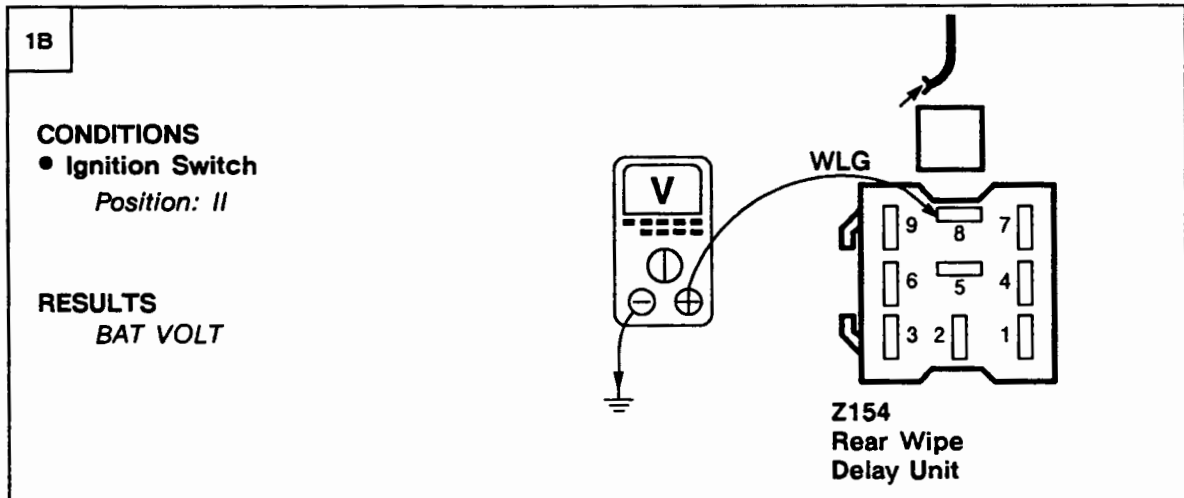

OK PROBLEM CAUSE
- WLG Wire

OK
↓
2B

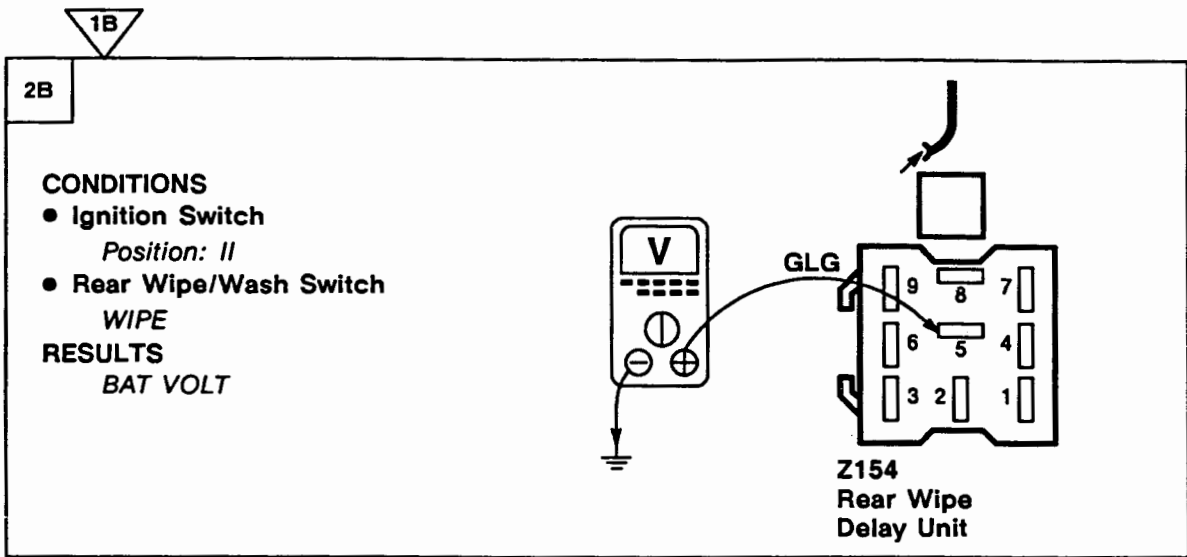

~~OK~~ PROBLEM CAUSE

- GLG Wire
- Rear Wipe/Wash Switch

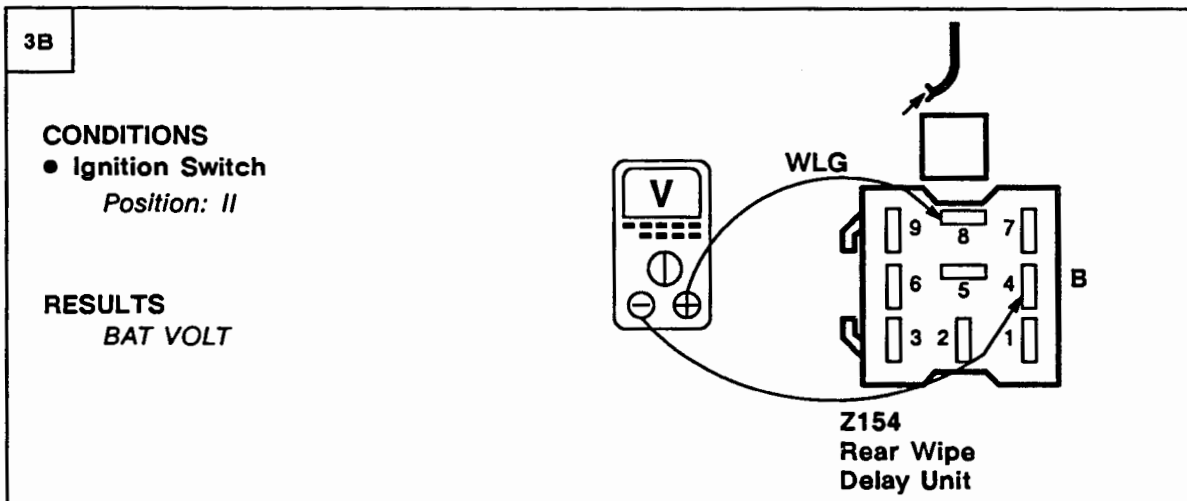
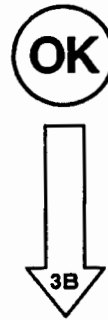

~~OK~~ PROBLEM CAUSE

- B Wire

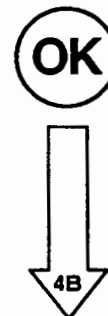

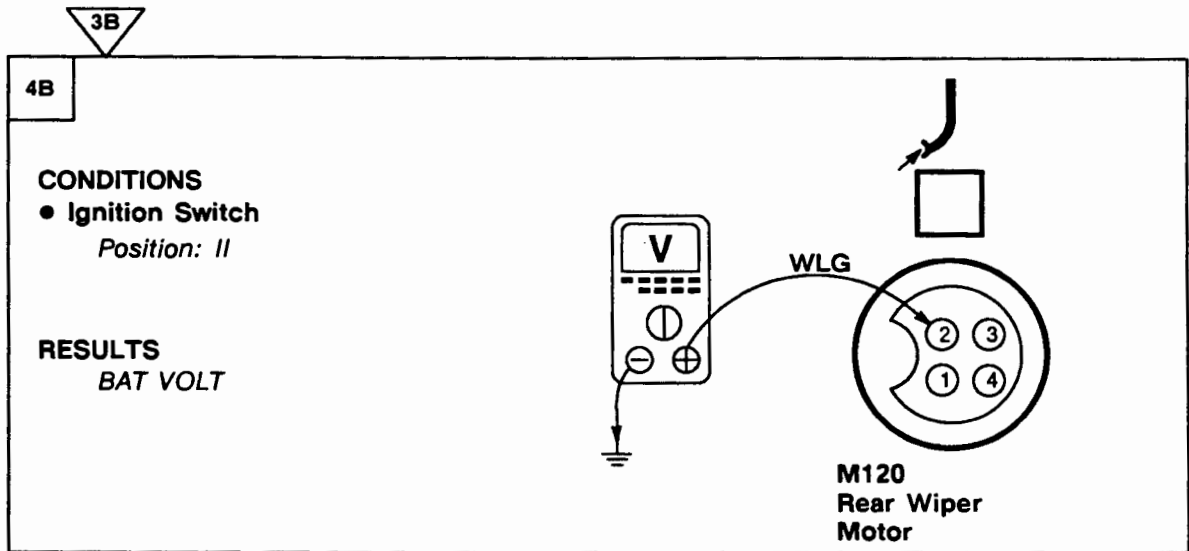

PROBLEM CAUSE

- WLG Wire
- F 3 Fuse

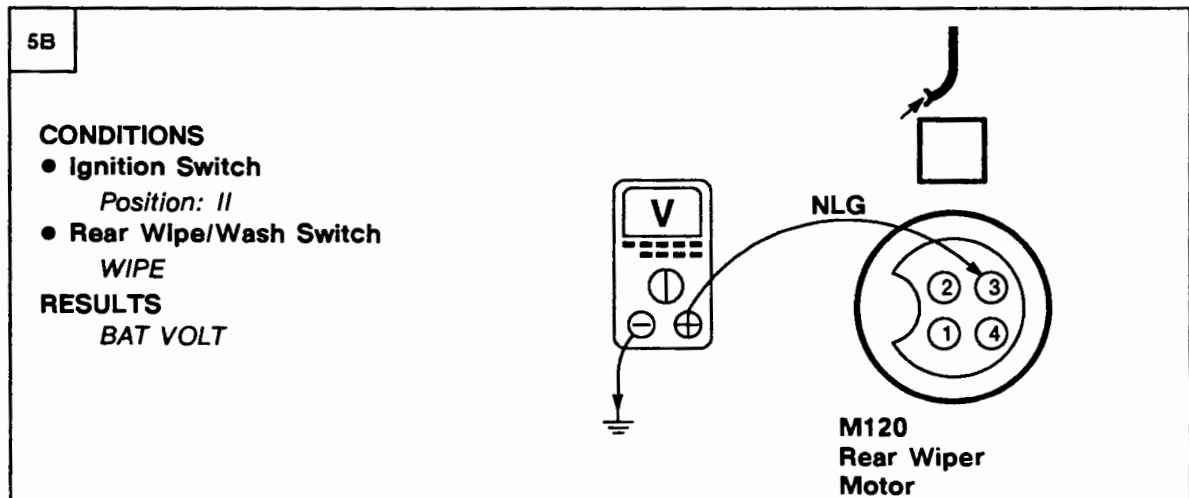
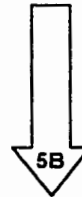

PROBLEM CAUSE

- NLG Wire
- Rear Wipe Delay Unit



PROBLEM CAUSE

- R Wire
- B Wire
- Rear Wiper Motor

Test C

1C

CONDITIONS

- Ignition Switch
Position: II
- Rear Wipe/Wash Switch
WASH

RESULTS
BAT VOLT

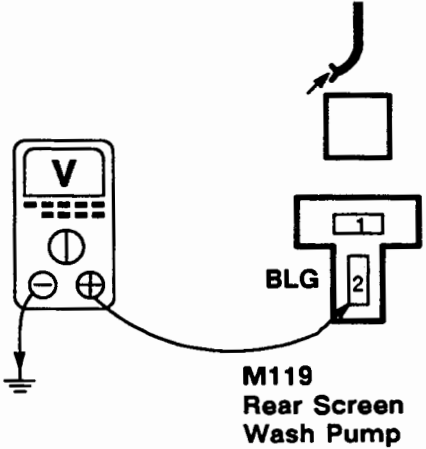

M119
Rear Screen
Wash Pump



PROBLEM CAUSE

- BLG Wire
- Rear Wipe/Wash Switch

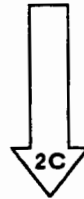

2C

CONDITIONS

- Ignition Switch
Position: 0

RESULTS
Less than 2 ohms

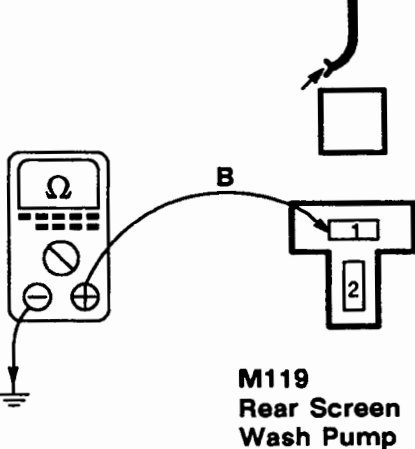

M119
Rear Screen
Wash Pump



PROBLEM CAUSE

- B Wire



PROBLEM CAUSE

- Rear Screen Wash Pump

Test D

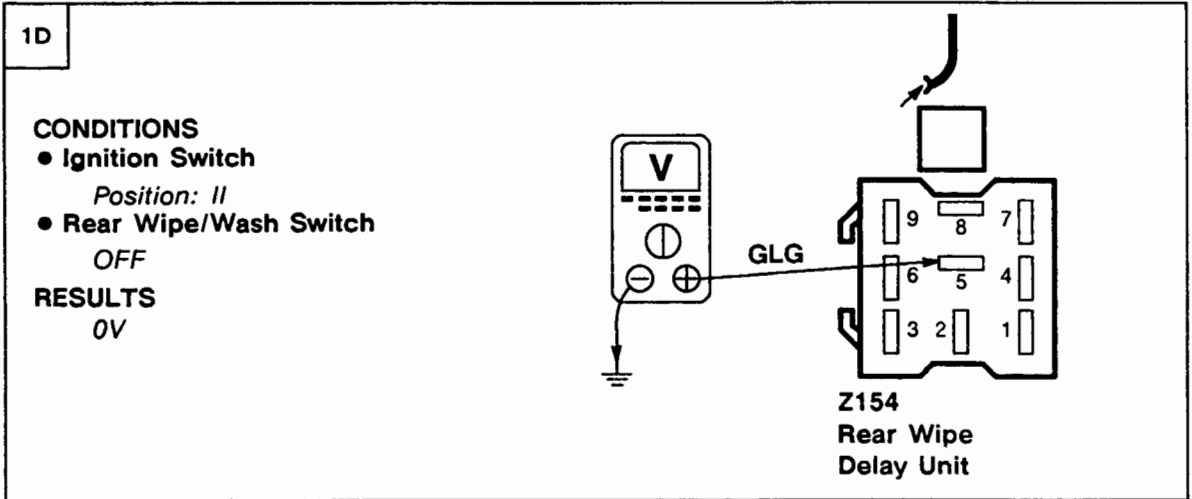

PROBLEM CAUSE
- Rear Wipe/Wash Switch

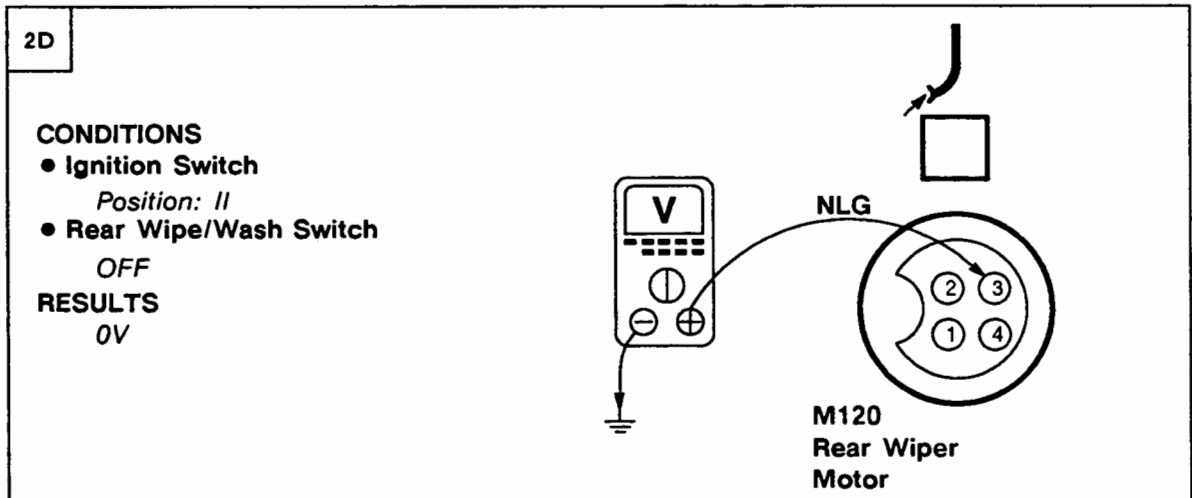
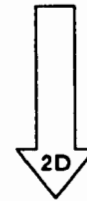

PROBLEM CAUSE
- Rear Wipe Delay Unit



PROBLEM CAUSE
- Rear Wiper Motor

1992 RANGE ROVER

KEY INFORMATION

CIRCUIT DIAGRAMS

- Circuit diagrams are arranged so that current flow is from the top of the diagram (current source) to the bottom of the diagram (earth).
- Only those components that work together in the circuit are shown. If only part of a component is used in the circuit, then only that part of the component is shown.
- Remember:

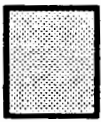

Entire component

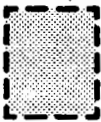

Part of a component

TERMINAL NUMBER

50

DESIGNATION

Battery voltage: Ignition Switch in position III

30

Battery voltage: supplied constantly

15

Battery voltage: Ignition Switch in position II or III

R

Battery voltage: Ignition Switch in positions I, II

31

Earth

See Introduction (i) for additional circuit diagram symbols.

DIAGNOSIS

- If the diagram is accompanied by text:
 - Read the Circuit Operation before proceeding with the electrical diagnosis.
 - Read the Troubleshooting Hints before performing the System Diagnosis.
 - Tests follow the System Diagnosis.
 - When performing the System Diagnosis, be certain that all components disconnected in previous steps are reconnected unless otherwise directed.



Component is disconnected.
Backprobe harness connector



Component is connected.
Backprobe harness connector



Component is disconnected.
Probe component



Component is disconnected.
Probe harness connector



Probe in-line connector

Wire Colour Chart

B- Black	P- Purple
G- Green	R- Red
K- Pink	S- Grey
L- Light	U- Blue
N- Brown	W- White
O- Orange	Y- Yellow

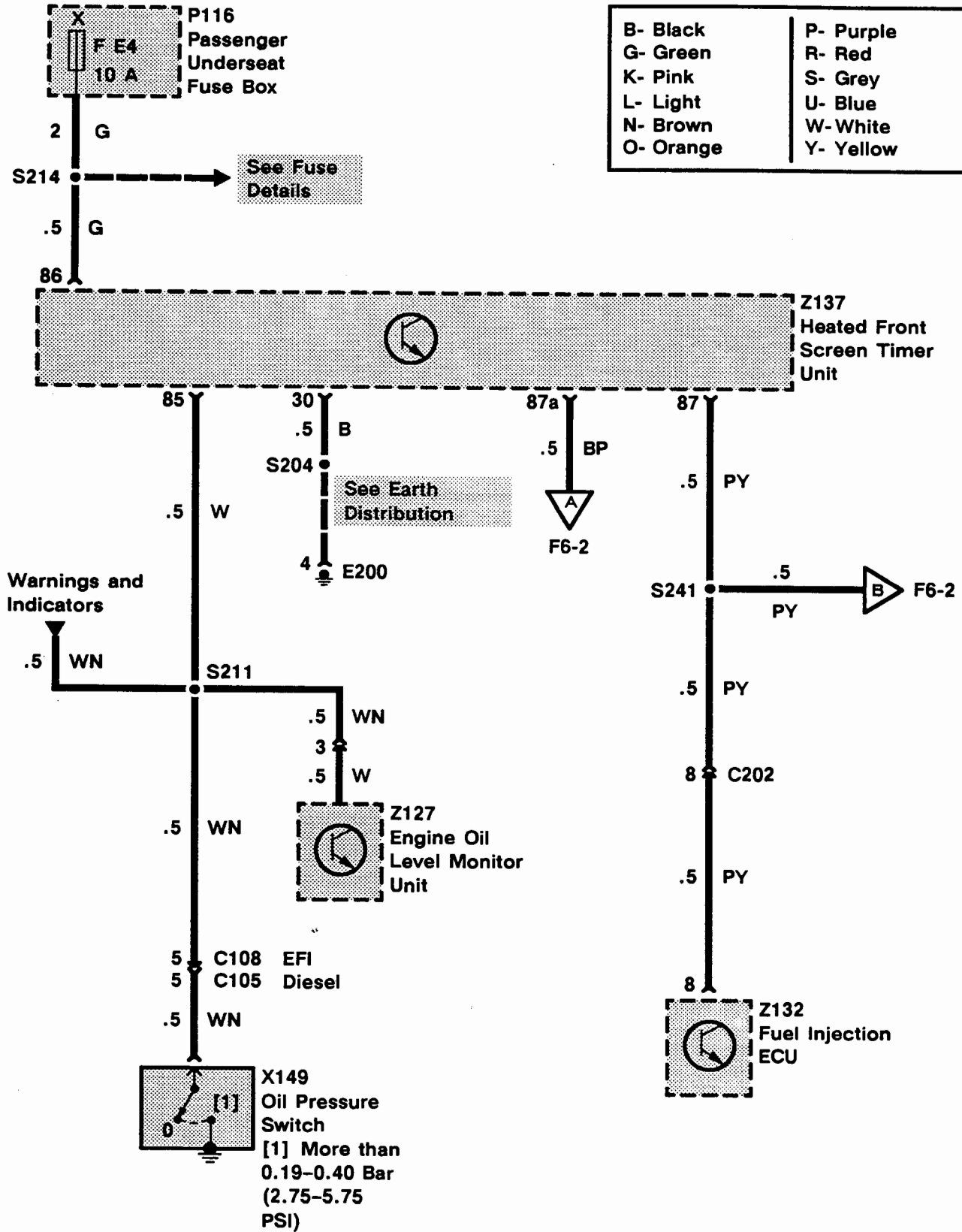

F6 ETM

1992 RANGE ROVER

Wire Colour Chart

B- Black	P- Purple
G- Green	R- Red
K- Pink	S- Grey
L- Light	U- Blue
N- Brown	W- White
O- Orange	Y- Yellow

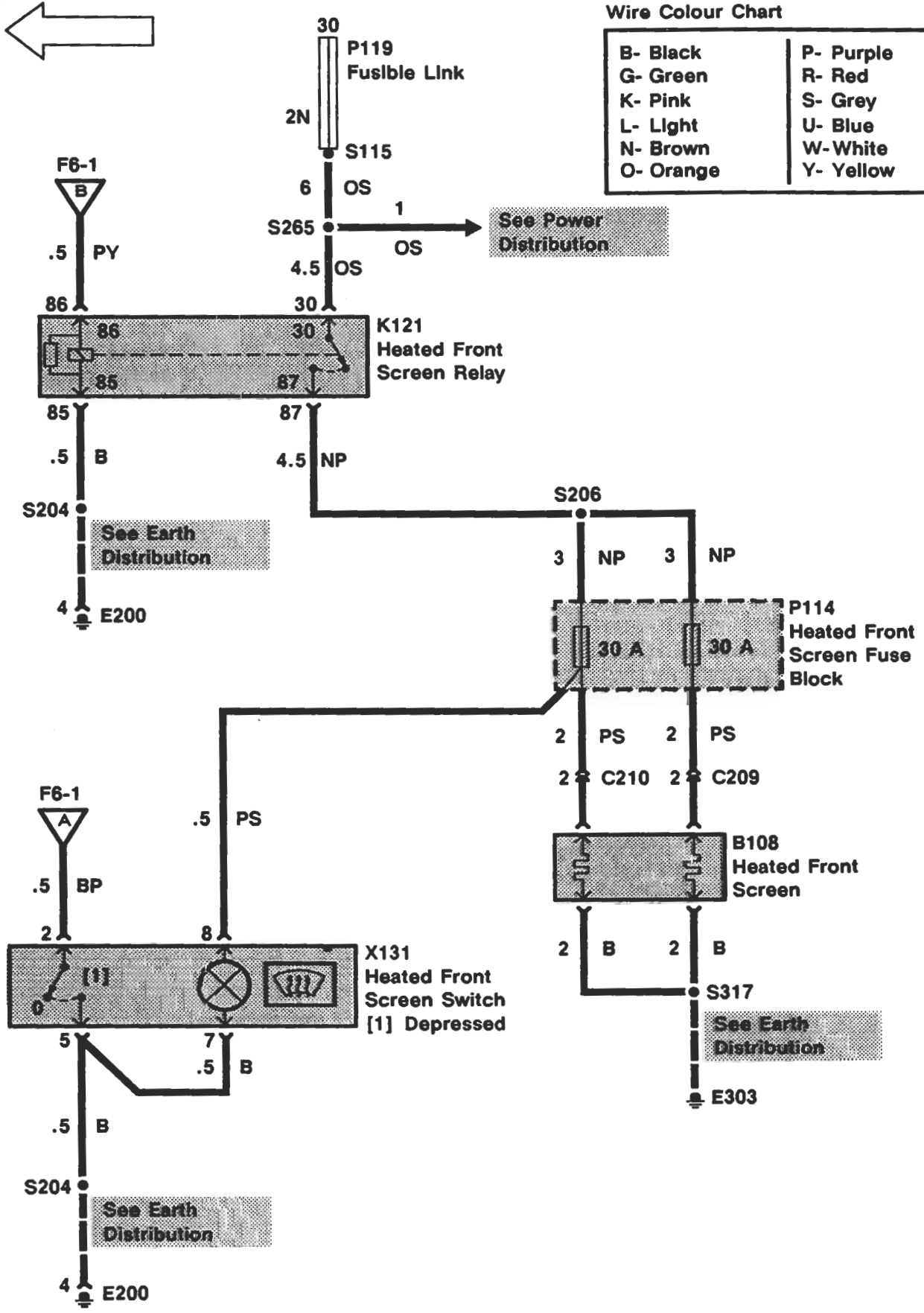

Wire Colour Chart

B- Black	P- Purple
G- Green	R- Red
K- Pink	S- Grey
L- Light	U- Blue
N- Brown	W- White
O- Orange	Y- Yellow

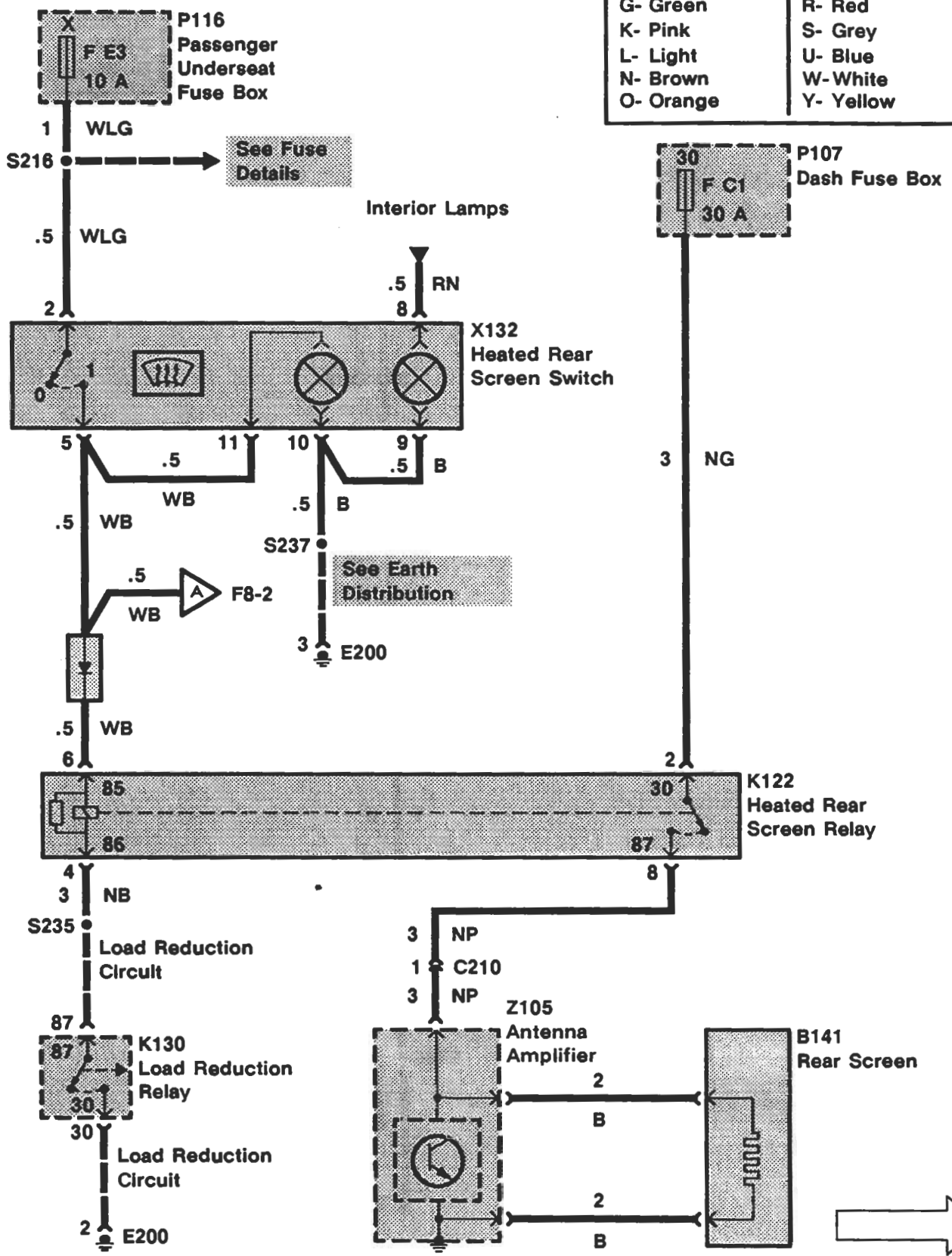

F8 ETM

1992 RANGE ROVER



Wire Colour Chart

B- Black	P- Purple
G- Green	R- Red
K- Pink	S- Grey
L- Light	U- Blue
N- Brown	W- White
O- Orange	Y- Yellow

