

**CIRCUIT OPERATION**

When the Ignition Switch (X134) is in position 1, voltage from Fuse B 1 is applied to the Front and Rear Window Relays (K114, K133), causing the relays to energize. With the relays energized, voltage is applied to the Rear Window Isolation Switch (X187), One Touch Window Control Unit (Z147), Passenger Window Switch (X151) and Rear Window Console Switches (X141, X162).

When a window console switch is in the DOWN position, voltage is applied to the window motor through the 'down' switch contacts. The window motors operate because they are earthed through the 'up' contacts of the window console switch.

When a switch is in the UP position, the polarity applied to the window motor is reversed, causing the motor to run in the opposite direction and the window to close. With the exception of the driver window, all of the windows operate as described.

**Driver Window Operation**

When the Driver Window Switch (X122) is in the DOWN position, terminal 7 of the One Touch Window Control Unit (Z147) is earthed through the switch. When this occurs, a relay in the One Touch Window Control Unit (Z147) energizes and applies voltage at terminal 6 of the Driver Window Motor (M130). The Driver Window Motor (M130) is earthed by the One Touch Window Control Unit (Z147) at terminal 5 through the 'up' contacts, allowing the motor to run.

If the switch is in the DOWN position for more than 400 milliseconds, the unit will fully lower the window. The window can be stopped by placing the switch in the UP position momentarily.

When the Driver Window Switch (X122) is in the UP position, terminal 4 of the One Touch Window Control Unit (Z147) is earthed. This signals the unit at terminal 5 to apply voltage to the motor. The one touch feature does not apply to the driver window up operation.

**Rear Window Isolation Switch (X187)**

The Rear Window Isolation Switch (X187) is placed in series with the voltage supply to the

Rear Window Door Switches (X188, X189). If the isolation switch is opened, the voltage supply is interrupted, preventing rear window operation using the rear door switches.

# L1 ETM

## 1992 RANGE ROVER

### Wire Colour Chart

B- Black	P- Purple
G- Green	R- Red
K- Pink	S- Grey
L- Light	U- Blue
N- Brown	W- White
O- Orange	Y- Yellow

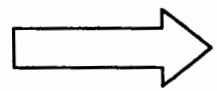
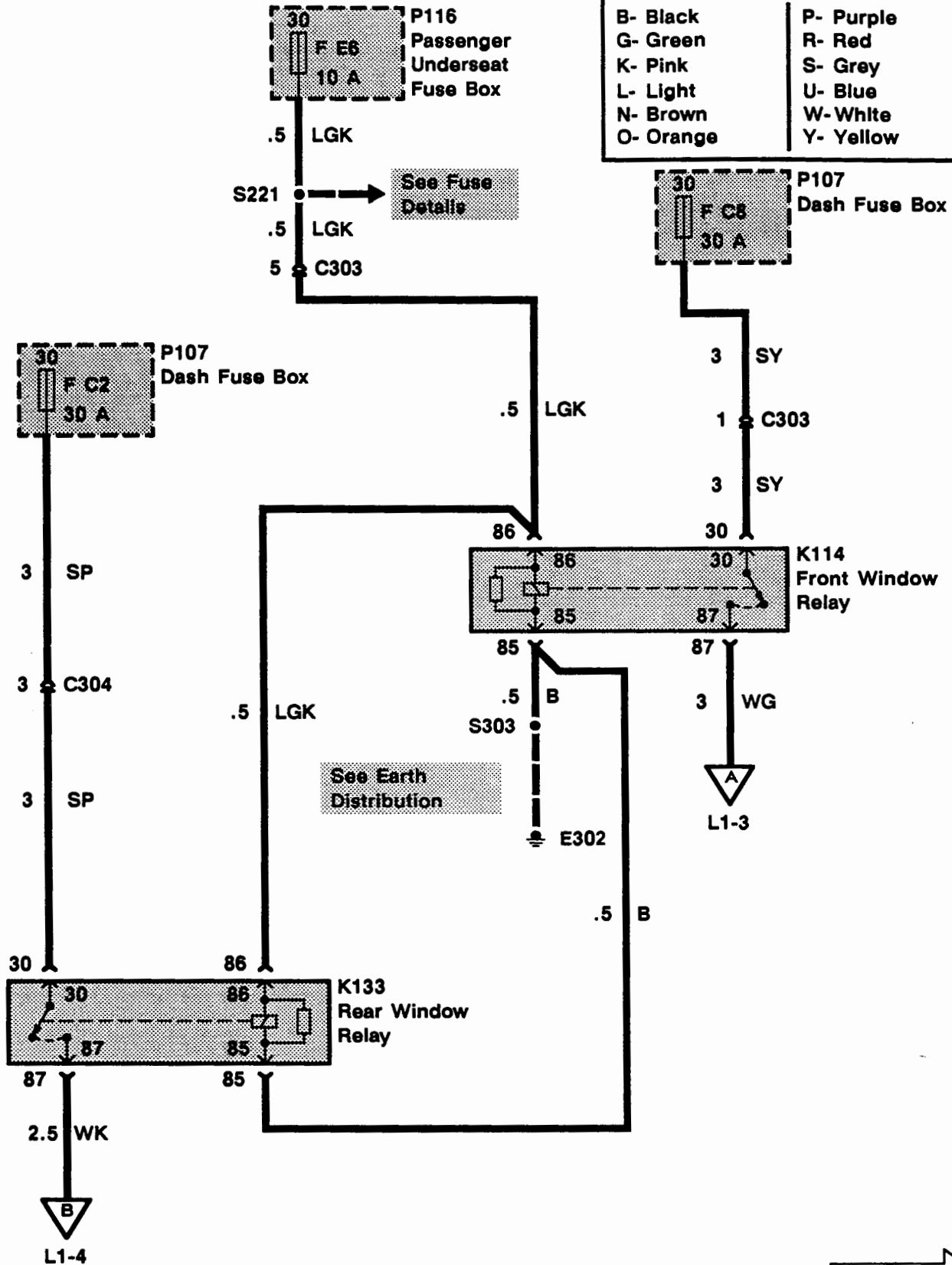

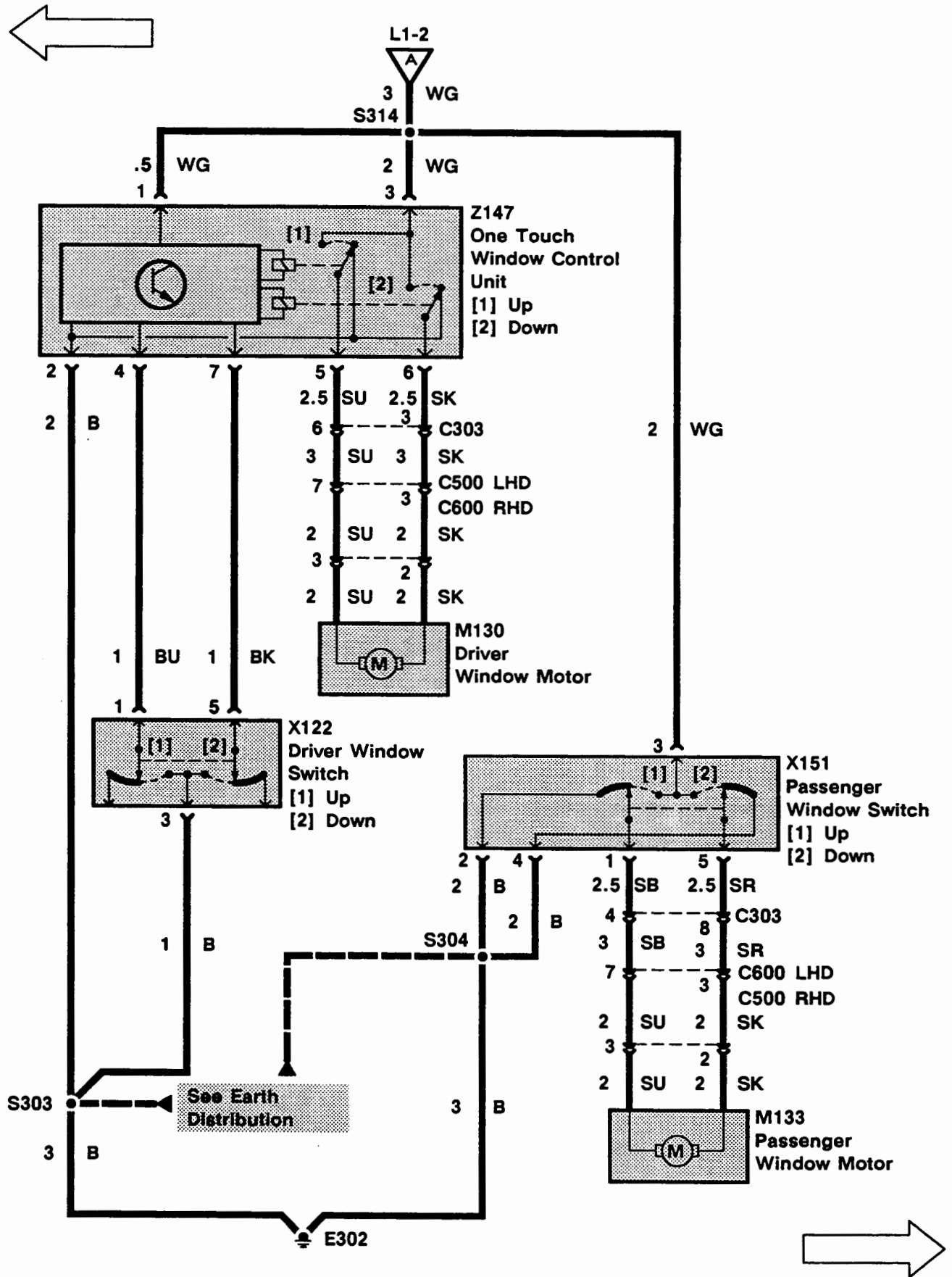

**L1 ETM**

**1992 RANGE ROVER**

**Wire Colour Chart**

B- Black	P- Purple
G- Green	R- Red
K- Pink	S- Grey
L- Light	U- Blue
N- Brown	W- White
O- Orange	Y- Yellow

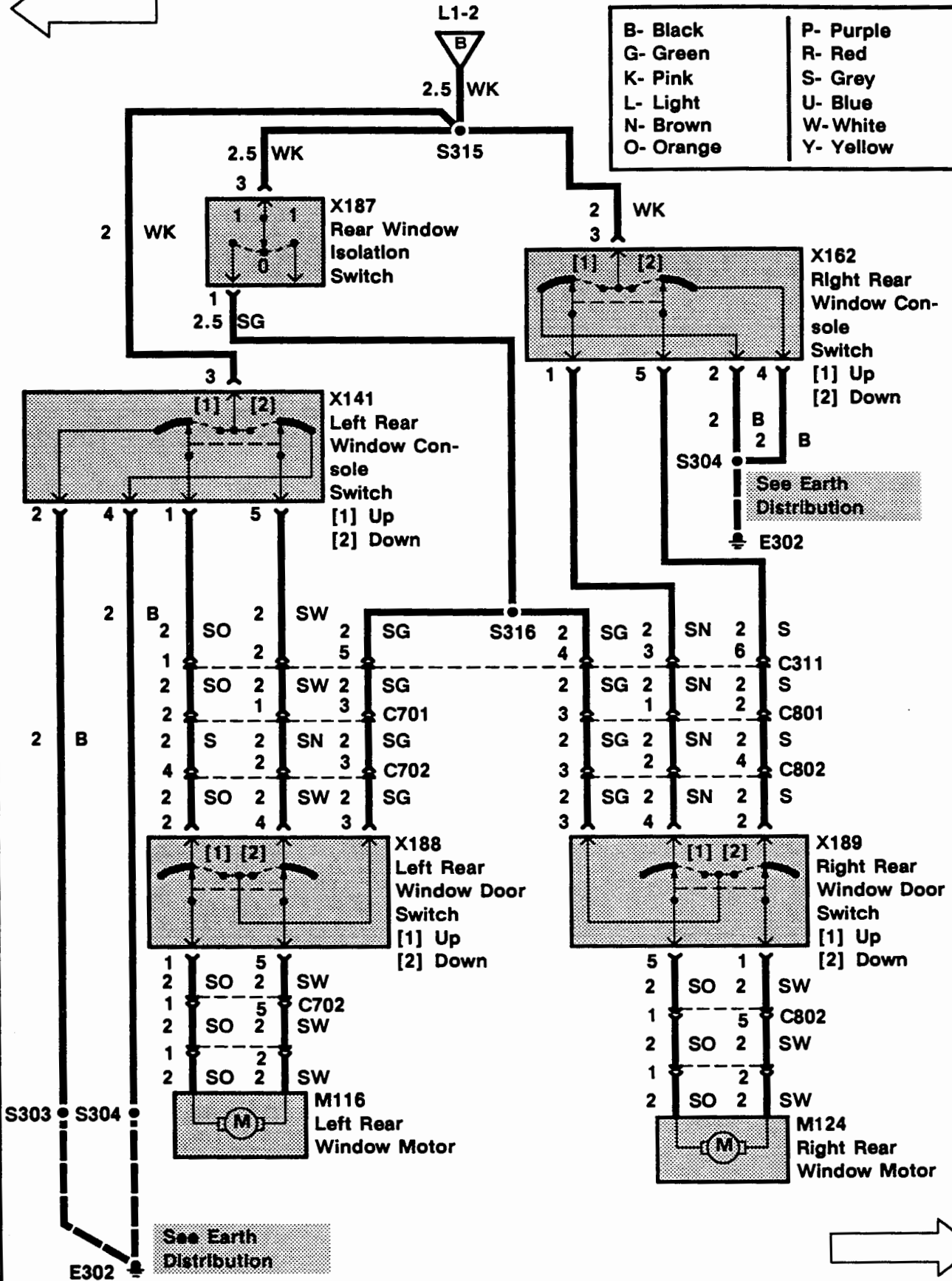

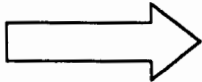
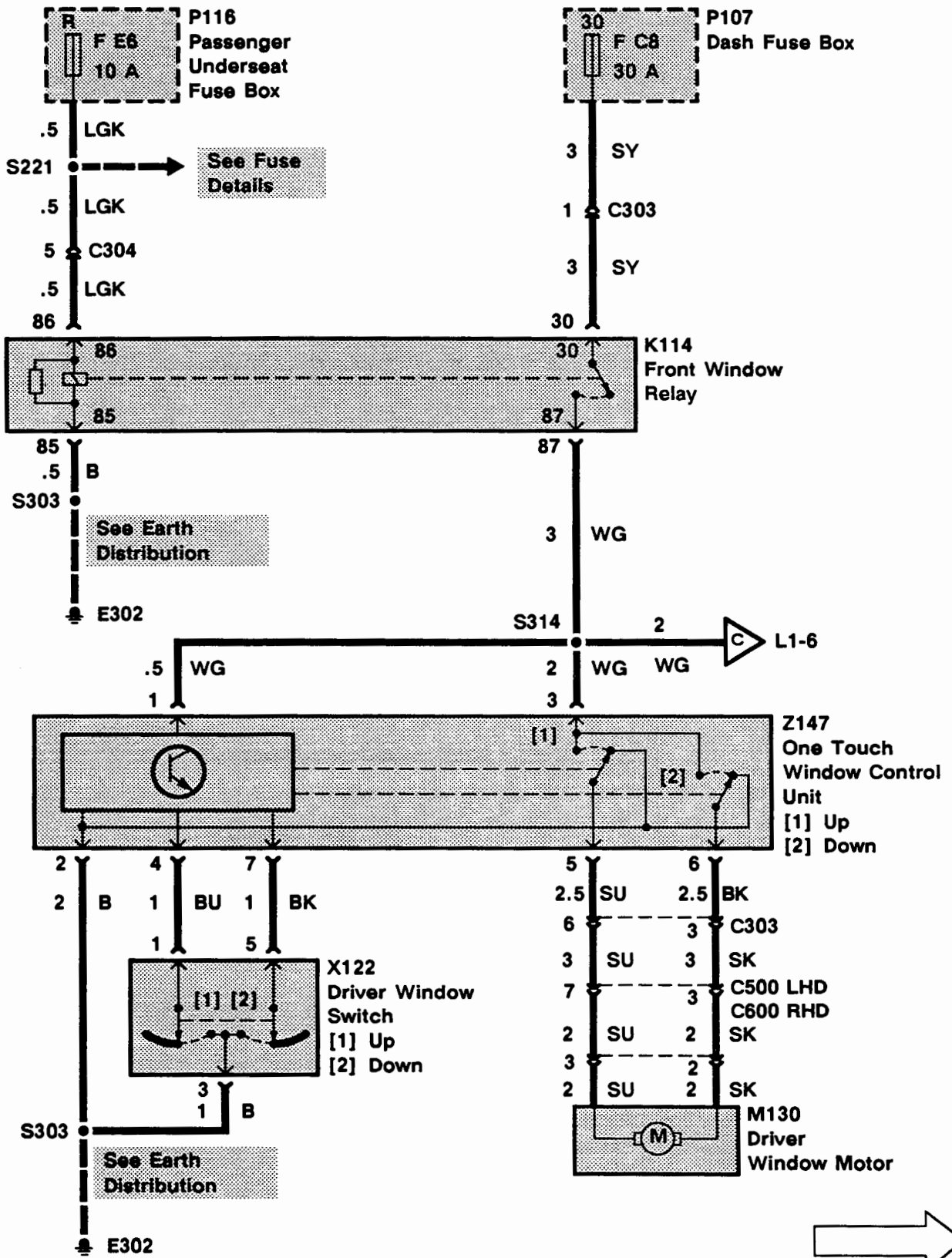
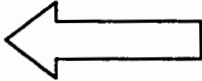

**L1 ETM**

1992 RANGE ROVER

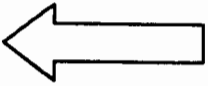

Wire Colour Chart

B- Black	P- Purple
G- Green	R- Red
K- Pink	S- Grey
L- Light	U- Blue
N- Brown	W- White
O- Orange	Y- Yellow

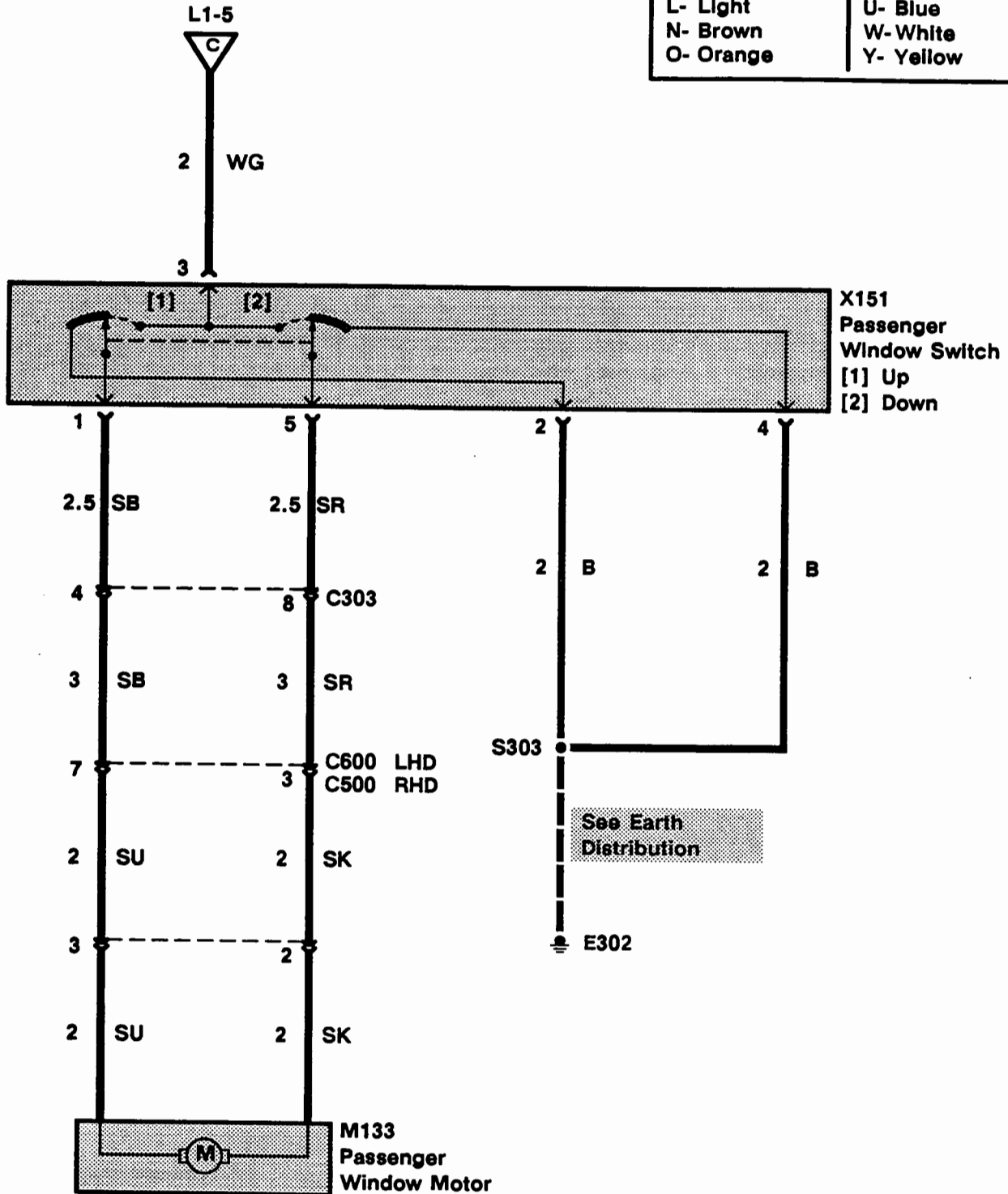

**TROUBLESHOOTING HINTS**

1. If the one touch window feature does not operate but the driver window operates, replace the One Touch Window Control Unit (Z147).

**SYSTEM DIAGNOSIS**

1. If both front and rear windows do not operate, do Test A.
2. If the rear windows do not operate from centre console switches but the front windows operate correctly, do Test B.
3. If the rear windows do not operate from the centre console switches and the rear door switches, do Test C.
4. If one rear window does not operate, do Test D.
5. If a rear window does not operate using the door switch but does operate from the centre console switch, do Test F.
6. If a rear window does not operate from the centre console switch but does work when the door switch is used, do Test E.
7. If both front windows do not operate but the rear windows do, do Test A.
8. If the front passenger window does not operate, do Test G.
9. If the driver window does not operate, do Test H.

**L1 ETM**

**1992 RANGE ROVER**

**Test A**

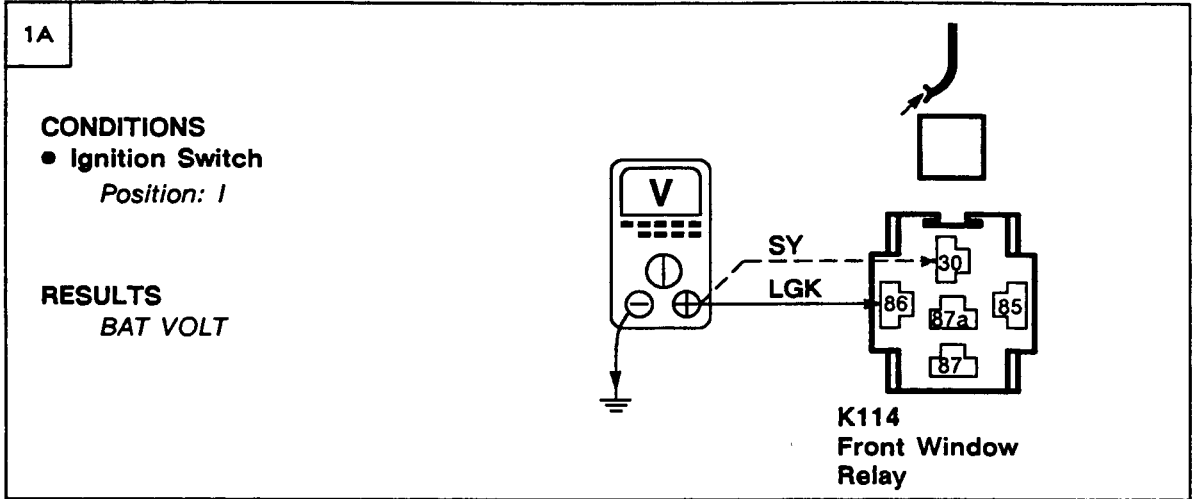

**PROBLEM CAUSE**

- F E6 Fuse
- LGK Wire
- SY Wire

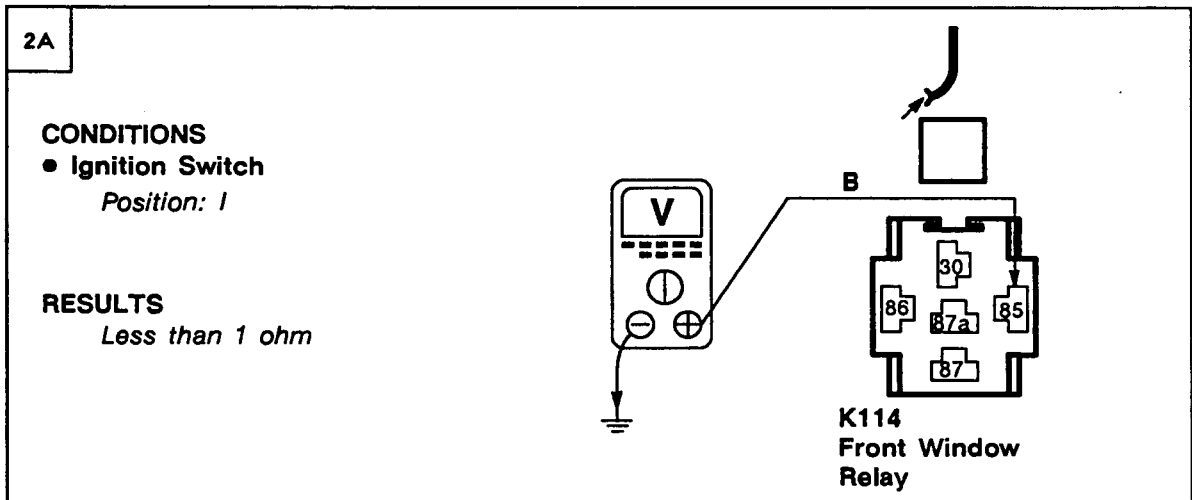

**PROBLEM CAUSE**

- B Wire
- E302

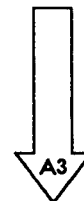



2A

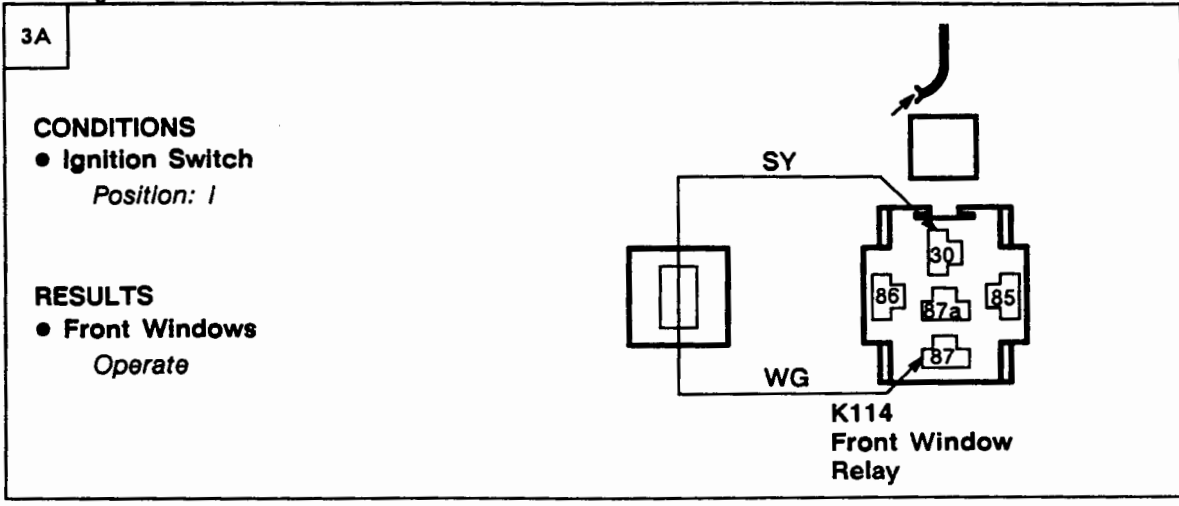

OK

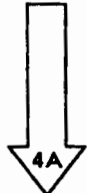

OK

PROBLEM CAUSE  
- Front Window Relay

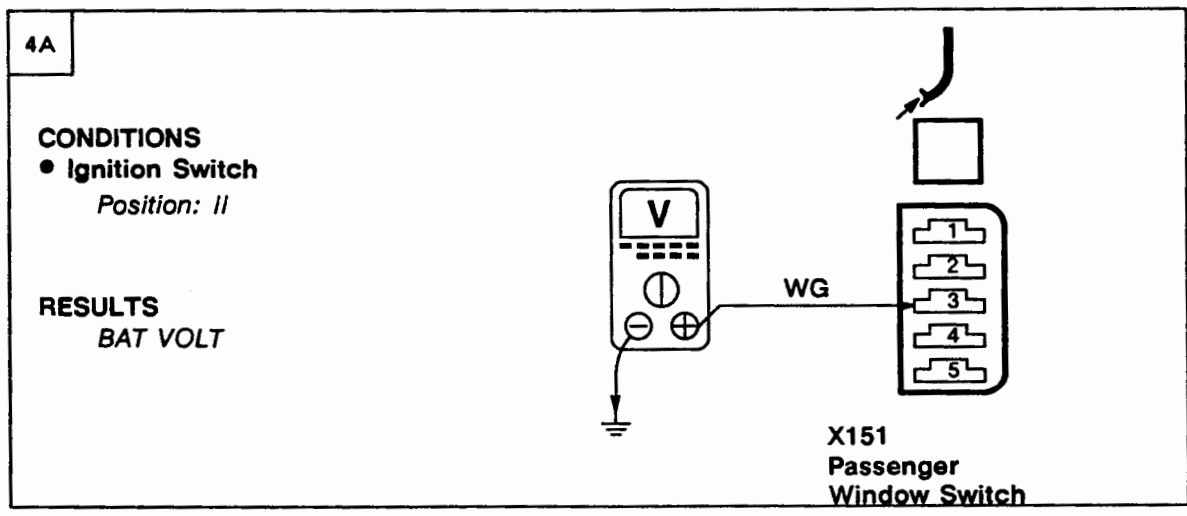

OK

PROBLEM CAUSE  
- WG Wire  
- One Touch Window Control Unit

OK

PROBLEM CAUSE  
- Passenger Window Switch

Test B

**1B**

**CONDITIONS**

- Ignition Switch  
*Position: I*

**RESULTS**  
*BAT VOLT*

X189  
Right Rear Window  
Door Switch

~~OK~~ PROBLEM CAUSE  
- WK Wire

OK



**2B**

**CONDITIONS**

- Ignition Switch  
*Position: I*

**RESULTS**

- Rear Windows  
*Work when operated*

X187  
Rear Window  
Isolation Switch

~~OK~~ PROBLEM CAUSE  
- SG Wire

OK PROBLEM CAUSE  
- Rear Window Isolation  
Switch

**Test C**

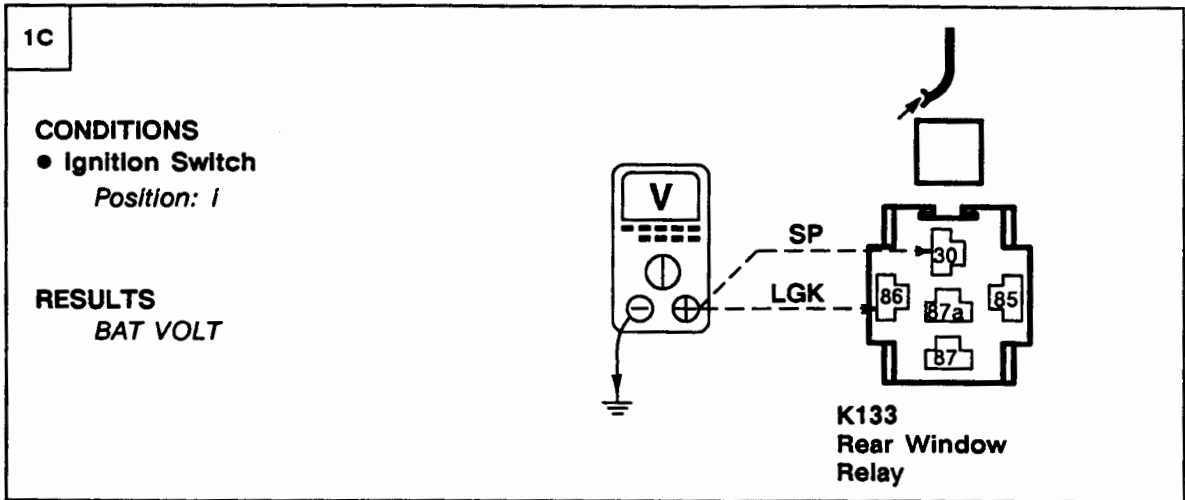

~~OK~~ **PROBLEM CAUSE**

- F C2 Fuse
- SP Wire
- LGK Wire

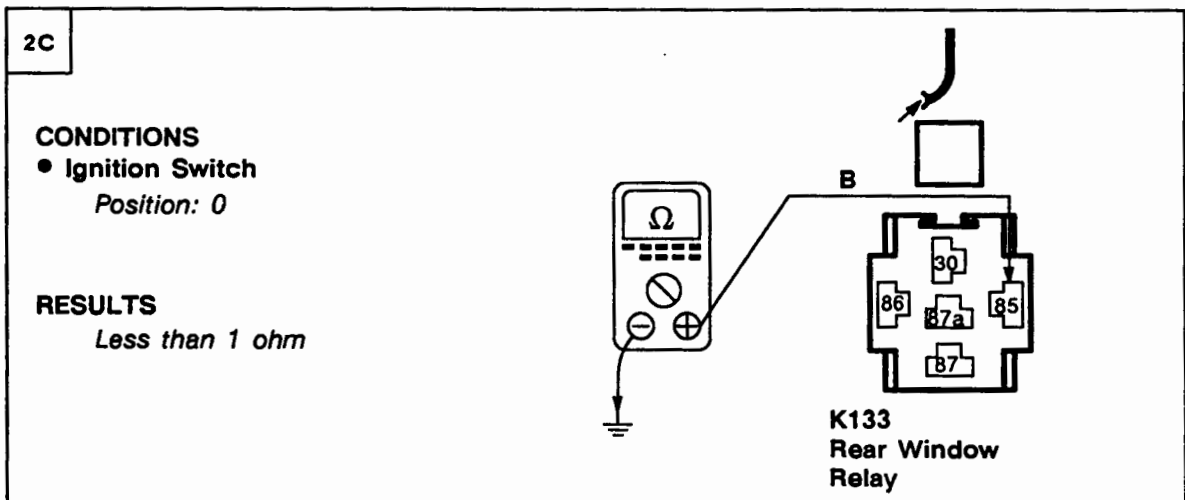
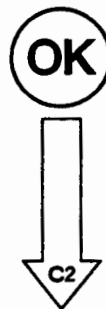

~~OK~~ **PROBLEM CAUSE**

- B Wire



2C

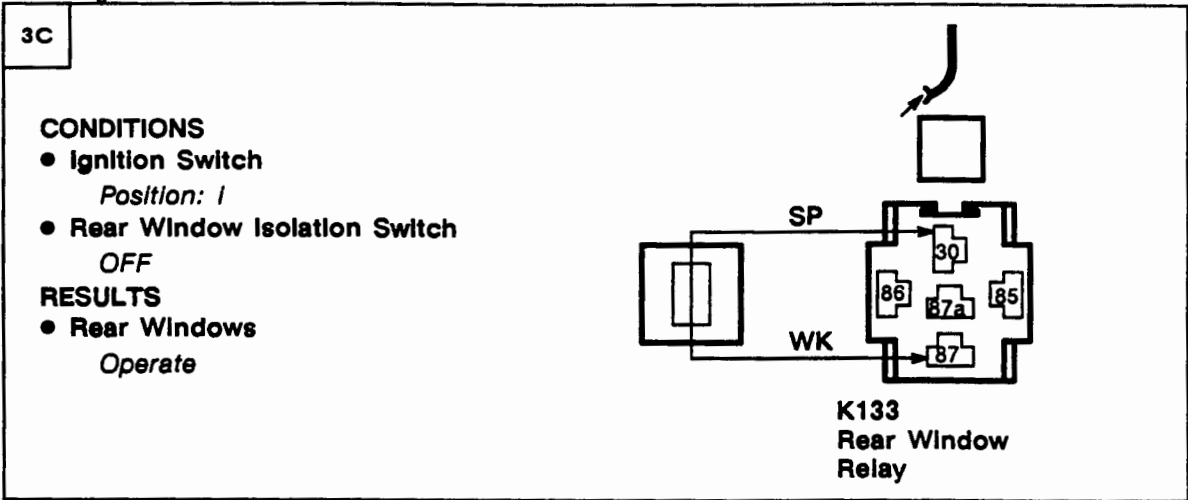

**PROBLEM CAUSE**

- WK Wire
- X141, X162 Rear Window Console Switch

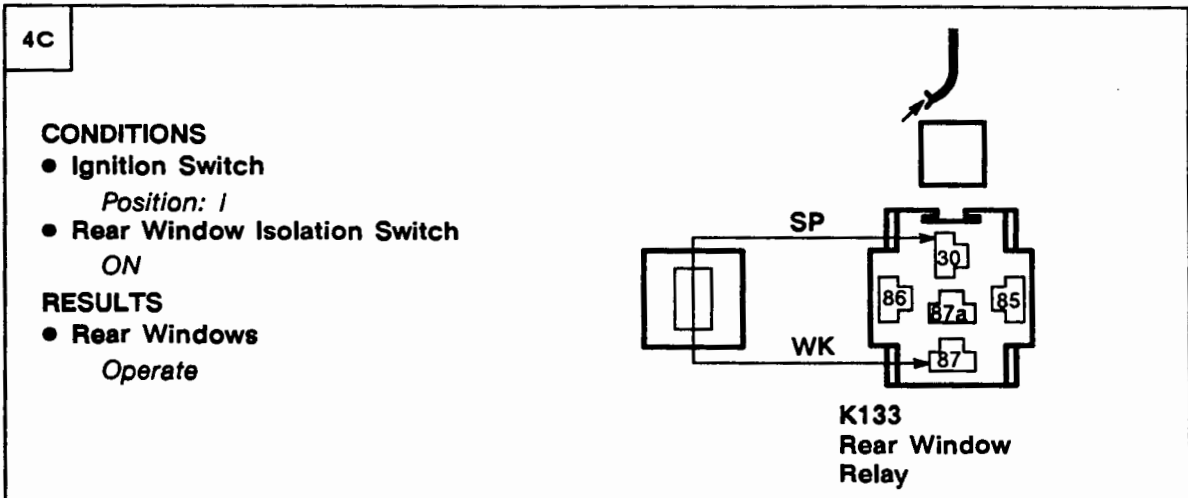

**PROBLEM CAUSE**

- SG Wire
- Rear Window Isolation Switch
- X141, X162 Rear Window Console Switch



**PROBLEM CAUSE**

- Rear Window Relay

Test D

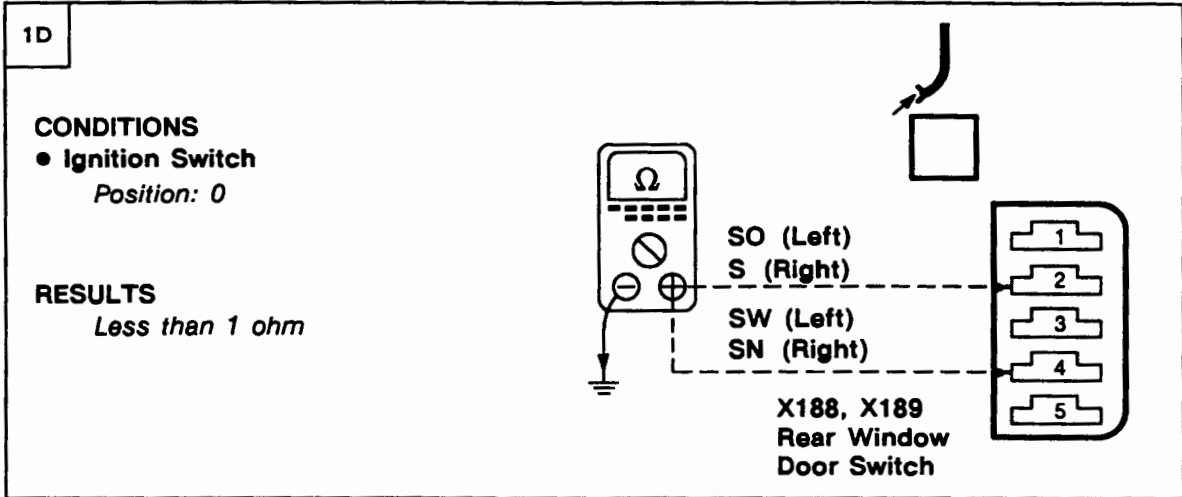

GO TO TEST E

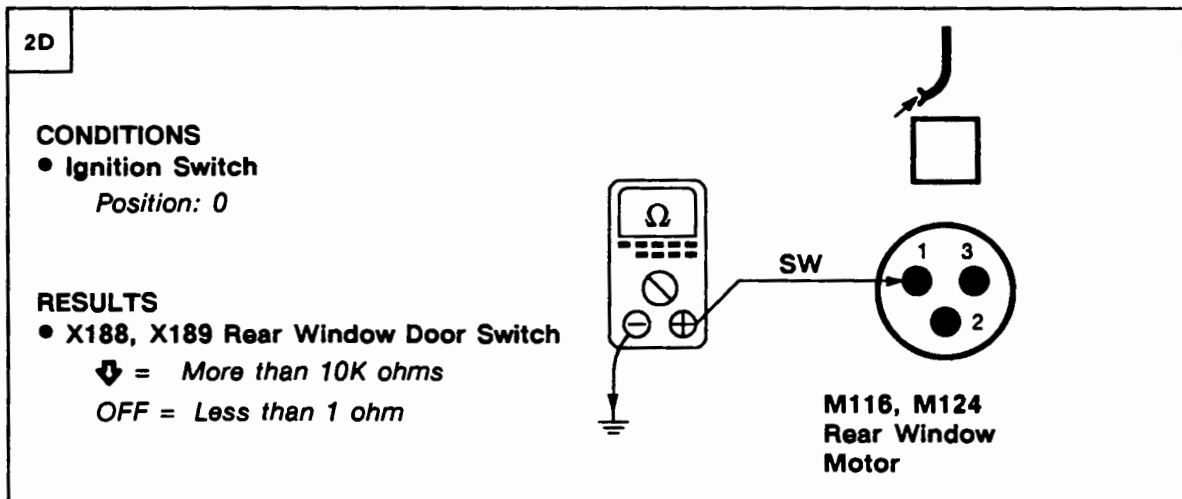
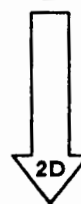

PROBLEM CAUSE

- SW Wire
- X188, X189 Rear Window Door Switch



**L1 ETM**

**1992 RANGE ROVER**

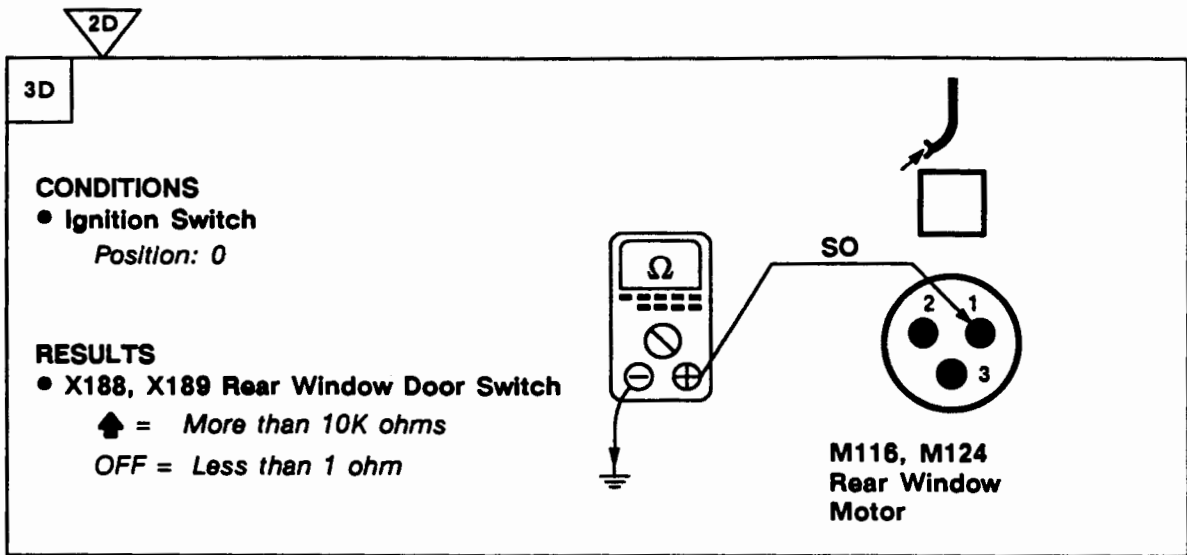

**PROBLEM CAUSE**

- SO Wire
- X188, X189 Rear Window Door Switch



**PROBLEM CAUSE**

- M116, M124 Rear Window Motor

**Test E**

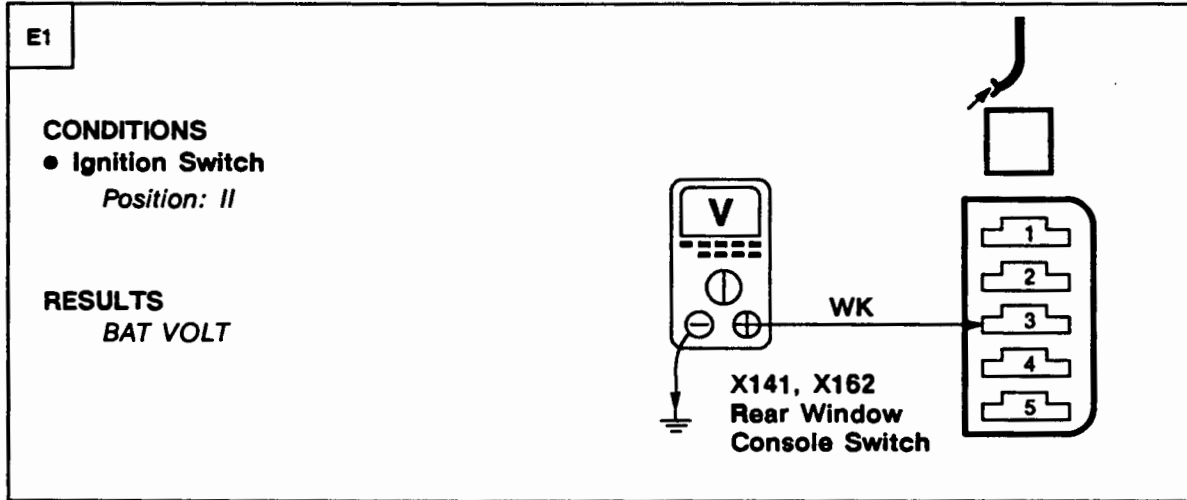

**PROBLEM CAUSE**

- WK Wire

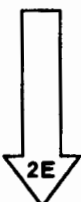

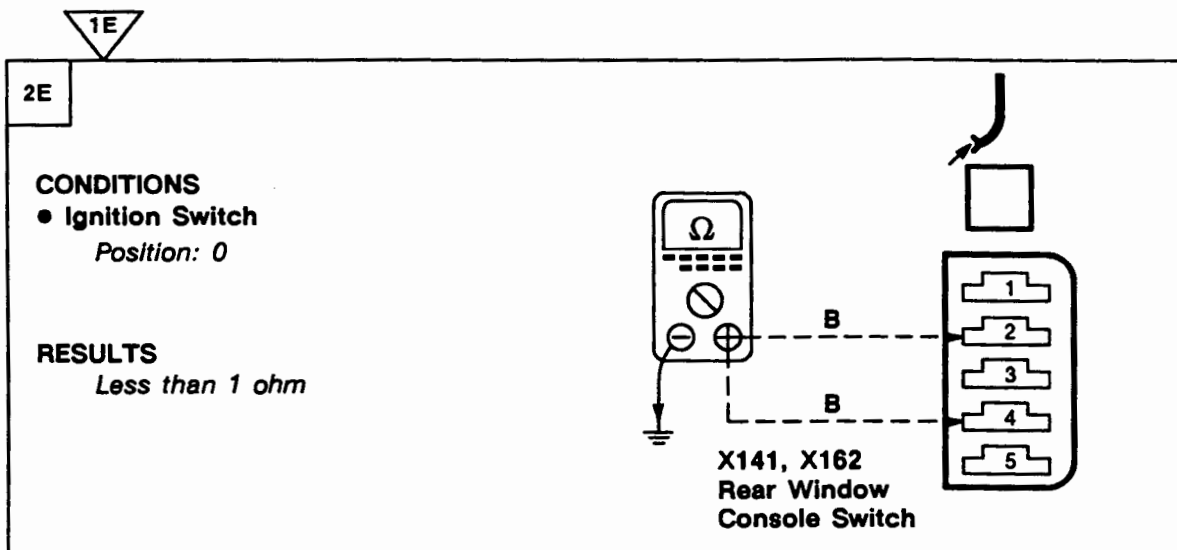

**OK** PROBLEM CAUSE  
- B Wire

**OK** PROBLEM CAUSE  
- X141, X162 Rear  
Window Console Switch

Test F

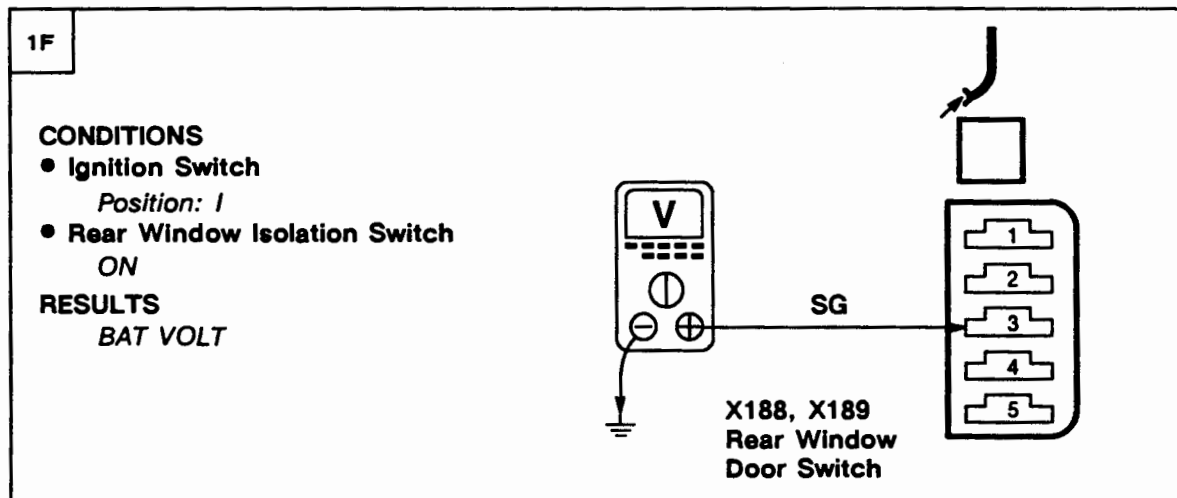

**OK** PROBLEM CAUSE  
- SG Wire

**OK** PROBLEM CAUSE  
- X188, X189 Rear  
Window Door Switch

Test G

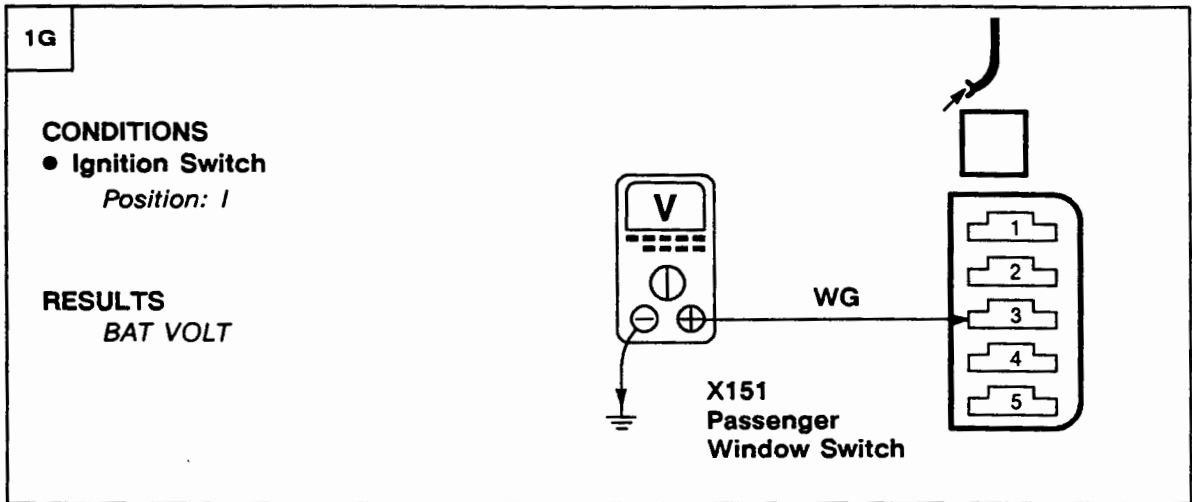

PROBLEM CAUSE  
 - WG Wire

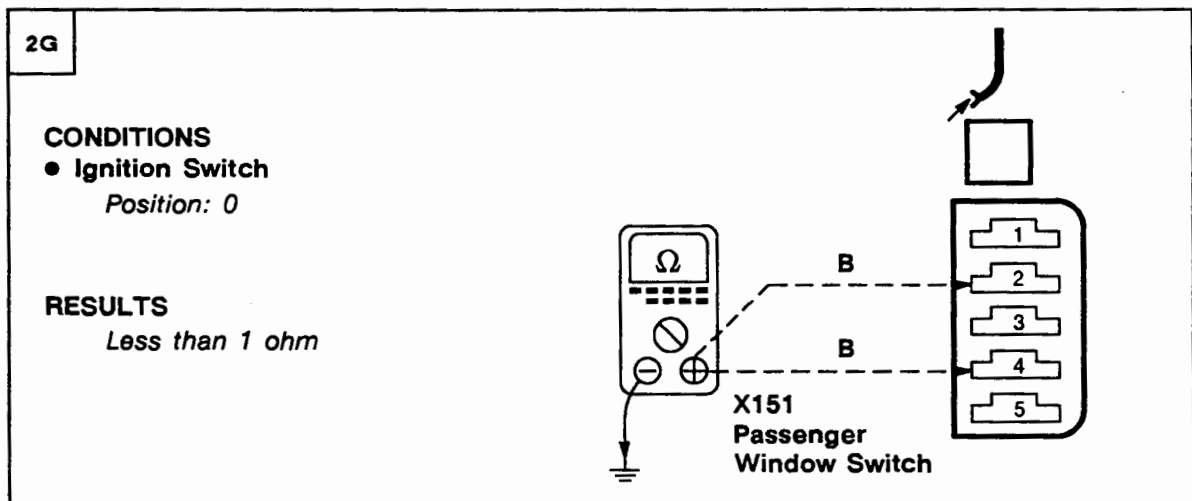

PROBLEM CAUSE  
 - B Wire

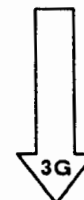



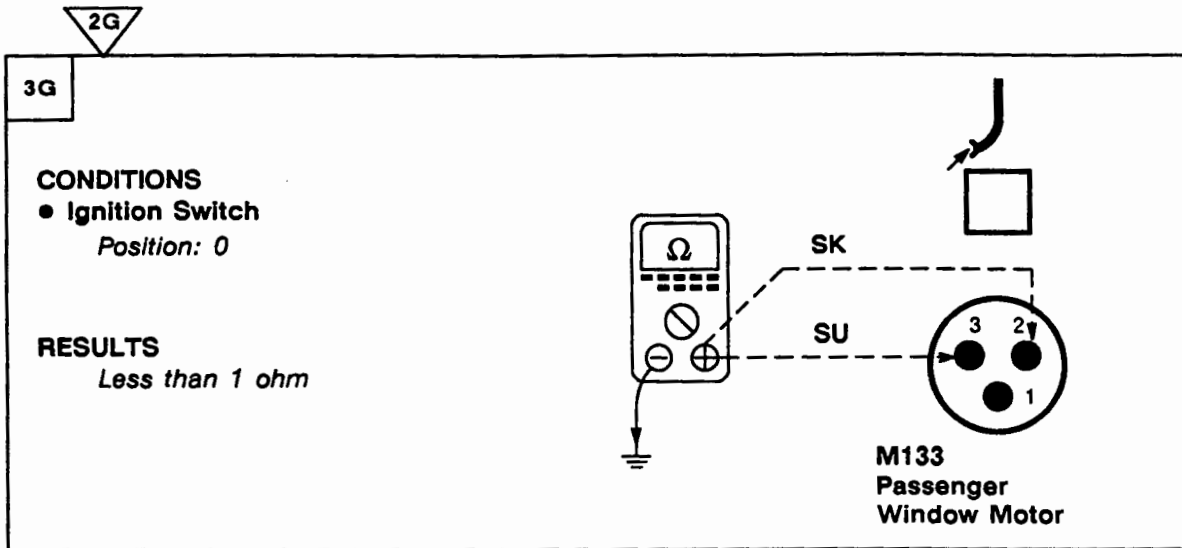

~~OK~~ PROBLEM CAUSE

- SK Wire
- SU Wire
- Passenger Window Switch

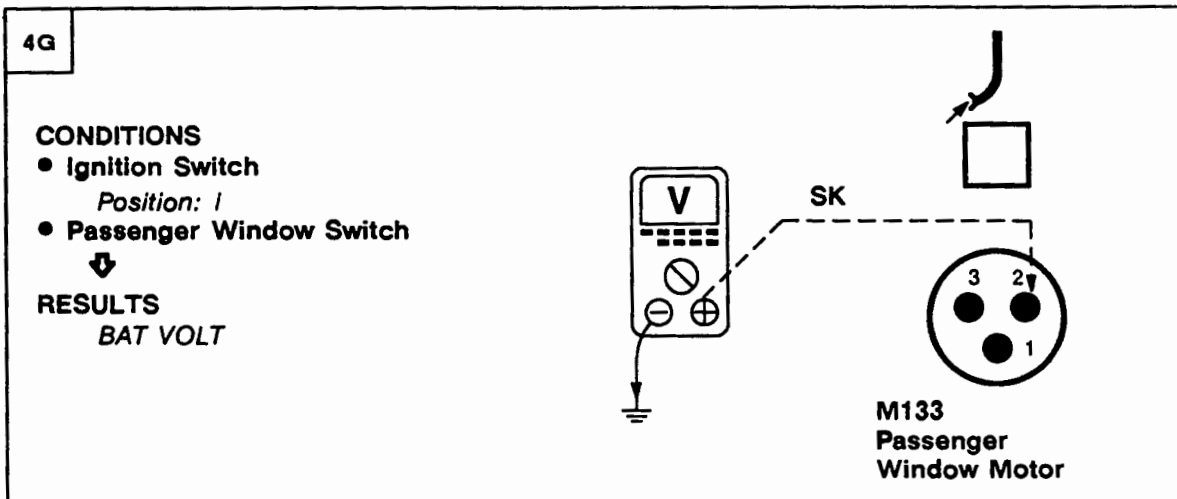

~~OK~~ PROBLEM CAUSE

- Passenger Window Switch

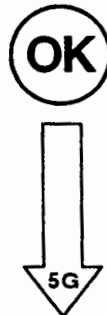

**L1 ETM**

**1992 RANGE ROVER**

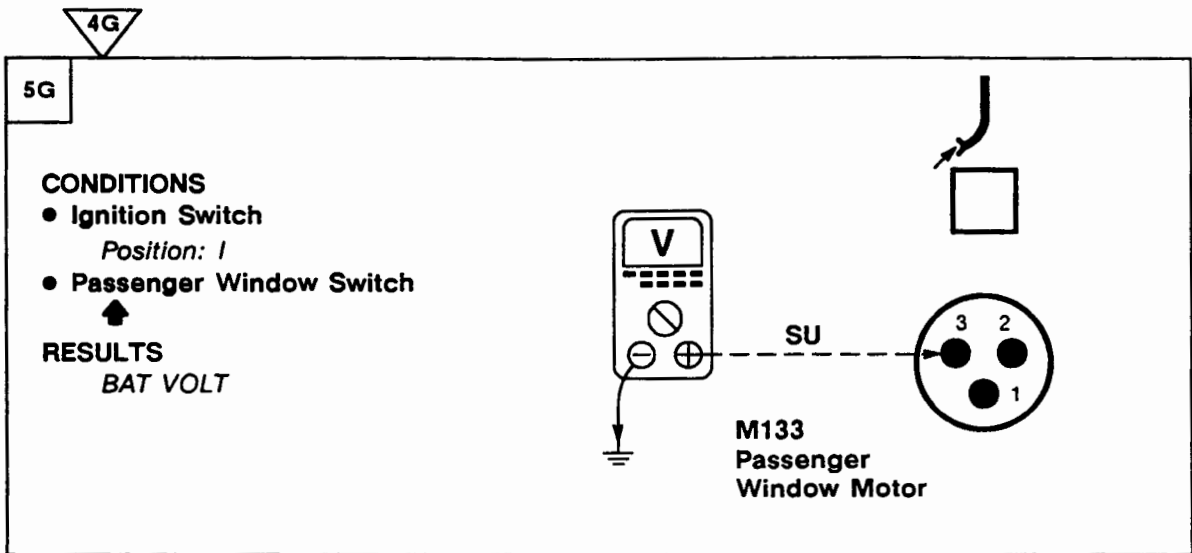

**PROBLEM CAUSE**  
- Passenger Window Switch



**PROBLEM CAUSE**  
- Passenger Window Motor

**Test H**

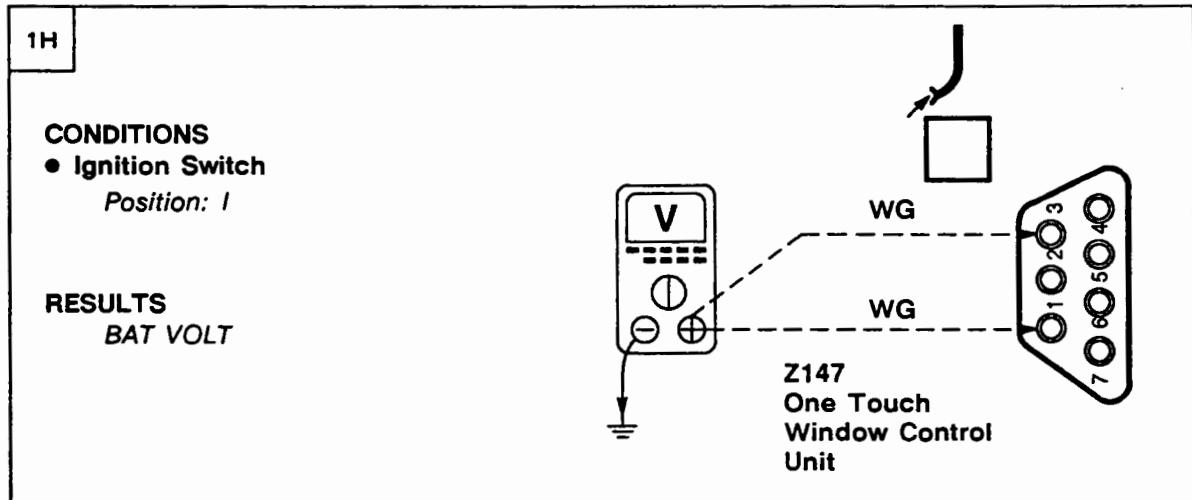

**PROBLEM CAUSE**  
- WG Wire

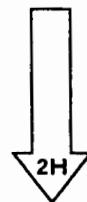

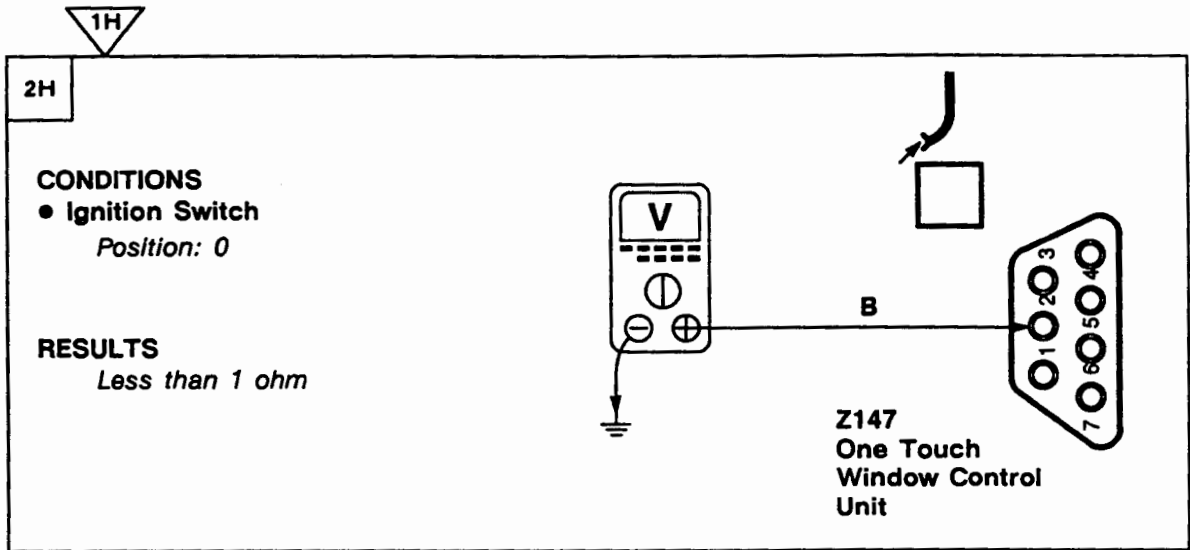

~~OK~~ PROBLEM CAUSE  
- B Wire

OK

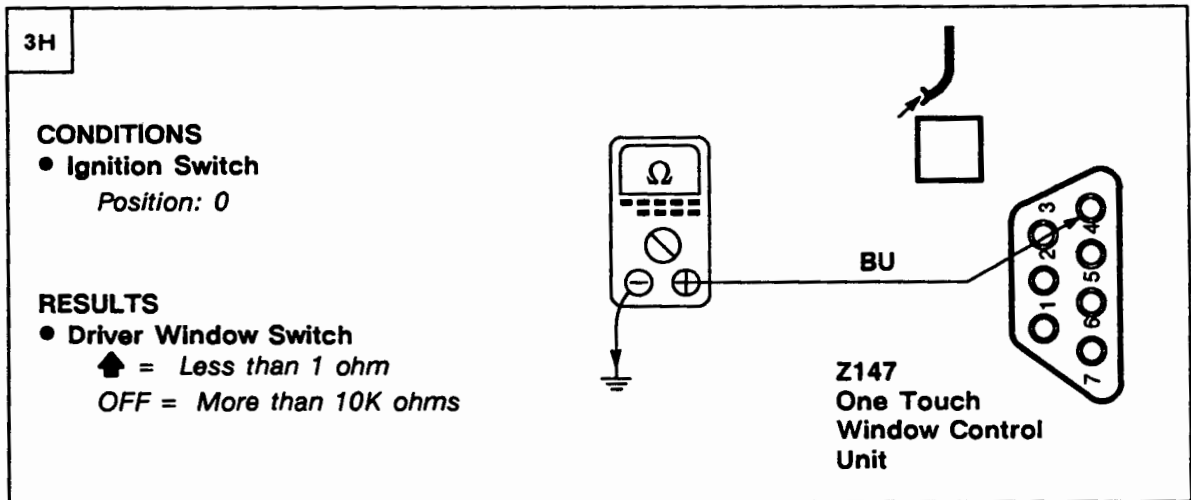

~~OK~~ PROBLEM CAUSE  
- BU Wire  
- B Wire  
- Driver Window Switch

OK



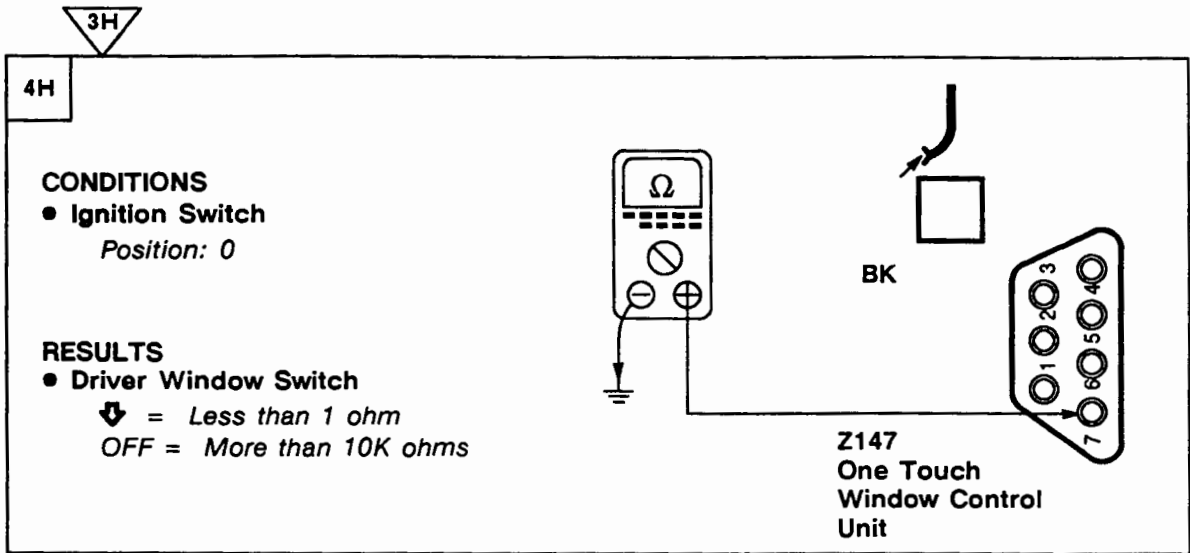

**PROBLEM CAUSE**

- BK Wire
- Driver Window Switch

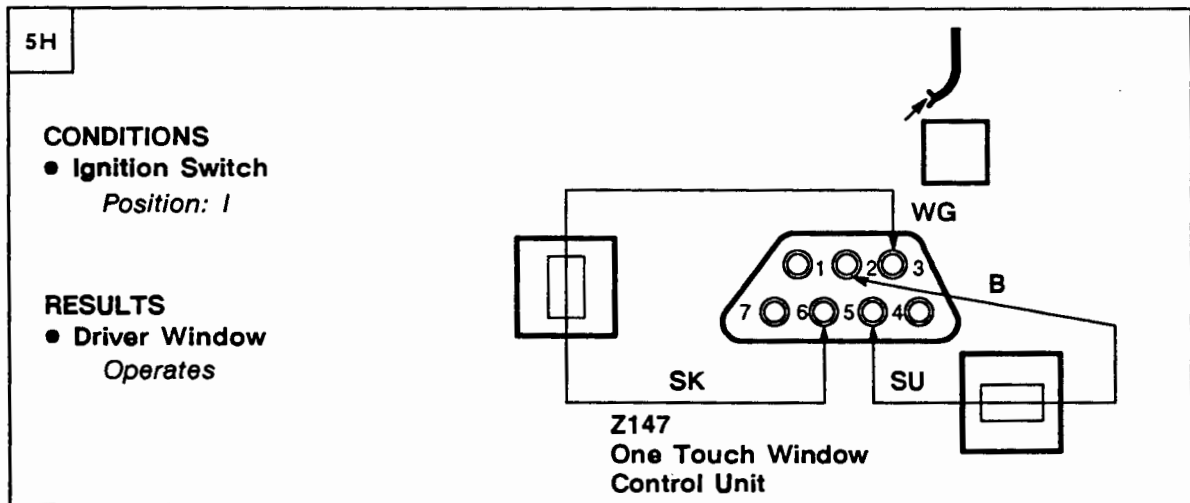

**PROBLEM CAUSE**

- SU Wire
- SK Wire
- Driver Window Motor



**PROBLEM CAUSE**

- One Touch Window Control Unit



# 1992 RANGE ROVER

## KEY INFORMATION

### CIRCUIT DIAGRAMS

- Circuit diagrams are arranged so that current flow is from the top of the diagram (current source) to the bottom of the diagram (earth).
- Only those components that work together in the circuit are shown. If only part of a component is used in the circuit, then only that part of the component is shown.
- Remember:

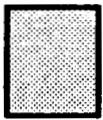

Entire component

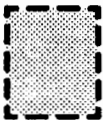

Part of a component

### TERMINAL NUMBER

50

### DESIGNATION

Battery voltage: Ignition Switch in position III

30

Battery voltage: supplied constantly

15

Battery voltage: Ignition Switch in position II or III

R

Battery voltage: Ignition Switch in positions I, II

31

Earth

See Introduction (i) for additional circuit diagram symbols.

### DIAGNOSIS

- If the diagram is accompanied by text:
  - Read the Circuit Operation before proceeding with the electrical diagnosis.
  - Read the Troubleshooting Hints before performing the System Diagnosis.
  - Tests follow the System Diagnosis.
  - When performing the System Diagnosis, be certain that all components disconnected in previous steps are reconnected unless otherwise directed.



Component is disconnected.  
Backprobe harness connector



Component is connected.  
Backprobe harness connector



Component is disconnected.  
Probe component



Component is disconnected.  
Probe harness connector



Probe in-line connector



## CIRCUIT OPERATION

The locking functions on 4 door models is controlled by the Central Locking Control Unit (Z113). On 2 door models the Driver Door Lock Switch (X117) controls the passenger door and tailgate locking functions.

### 2 Door Operation

Power to the Driver Door Lock Switch (X117) for the locking functions is supplied by fuse F C7 through the NK wire. The switch is earthed at E200 through the B wire.

When the driver's door is locked, the Driver Door Lock Switch applies voltage from terminal 3 to terminal 1 of the Passenger Door Lock Actuator (M118) and to terminal 2 of the Tailgate Lock Actuator (M132). At the same time the Driver Door Lock Switch also applies earth to the lock actuators momentarily when the driver's door is locked. The lock actuators' path to earth is through terminal 4 of the Driver Door Lock Switch. The switch earths the actuators at E200 through its contacts. When the lock actuators are momentarily earthed, the actuators move to the locked position.

When the driver's door lock is unlocked, the Driver Door Lock Switch reverses the voltage applied to the actuators. The Driver Door Lock Switch now applies earth through its terminal 3 to the lock actuators. Voltage to unlock the actuators is supplied momentarily by the Driver Door Lock Switch at terminal 4 through the O and K wires.

### 4 Door Operation

Fuses F C7 and F 2 supply voltage to the Central Locking Control Unit (Z113) for the locking functions. The control unit is earthed at terminal 11 to earth E200.

### Inputs

The Central Locking Control Unit (Z113) monitors the position of the front door locks through input switches that are part of the Front Door Lock Actuators (M114, M122). When the control unit sees an input switch change position, the control unit responds by locking or unlocking the doors.

### Lock

The Central Locking Control Unit (Z113) locks the doors by momentarily applying battery voltage at its terminal 8 to the actuators through the K wire. The lock actuators are earthed by the Central Locking Control Unit at terminal 7 through the O wire. The actuators now move to the locked position.

### Unlock

To unlock the doors the Central Locking Control Unit (Z113) momentarily applies battery voltage from terminal 7 to the actuators through the O wire. The actuators are earthed by the Central Locking Control Unit at terminal 8 through the K wire. The lock actuators now unlock.

### Fuel Flap

When the Fuel Flap Release Switch (X125) is operated, voltage from fuse F C6 is applied to the Fuel Flap Actuator (M108) through the switch, the YK wire and the YP wire. The actuator is earthed to the Fuel Filler Pipe (P110) and earth E402.

**THIS PAGE HAS BEEN INTENTIONALLY LEFT BLANK**



Wire Colour Chart

B- Black	P- Purple
G- Green	R- Red
K- Pink	S- Grey
L- Light	U- Blue
N- Brown	W- White
O- Orange	Y- Yellow

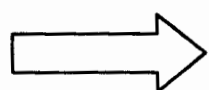
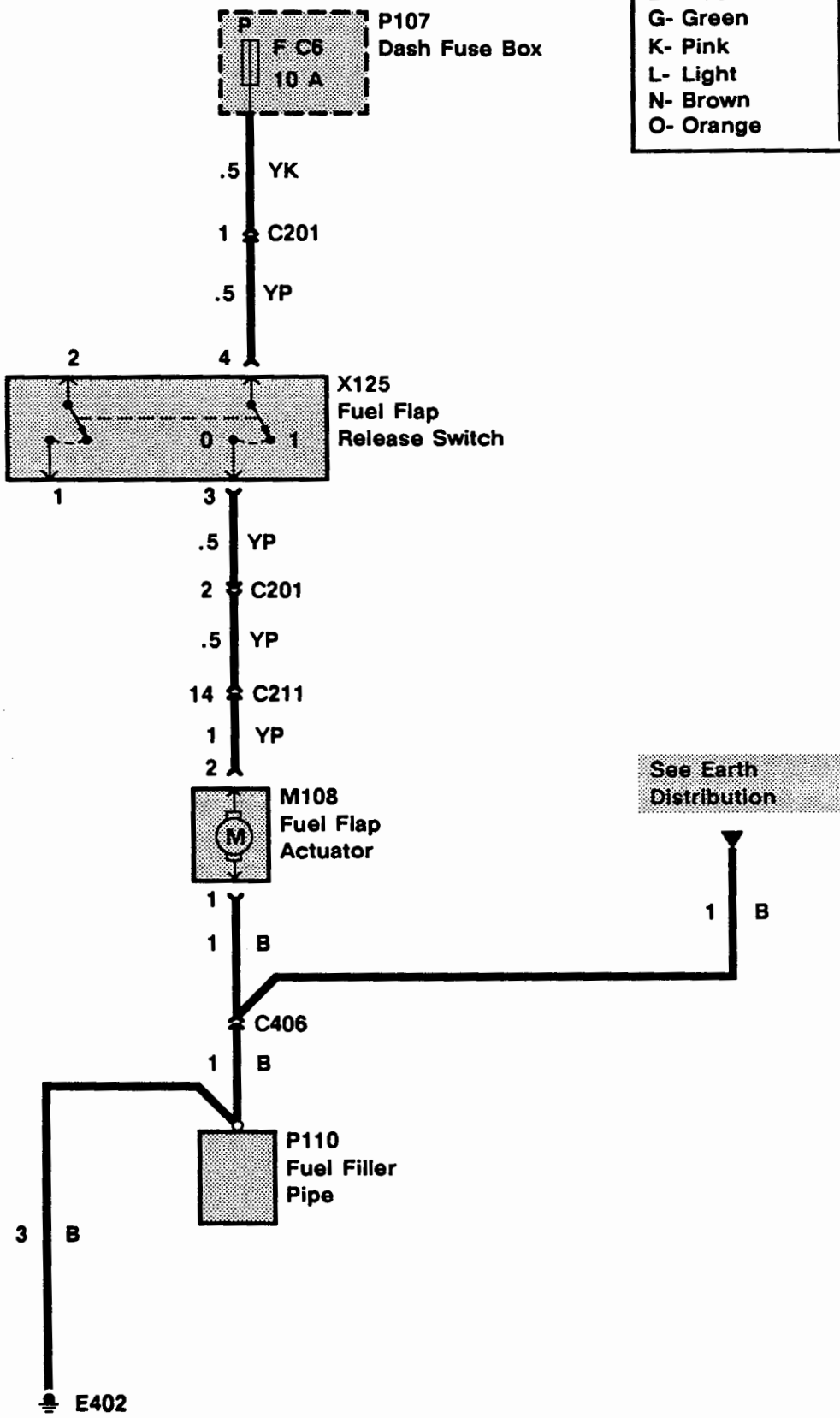

**L6 ETM**

**1992 RANGE ROVER**

Wire Colour Chart

B- Black	P- Purple
G- Green	R- Red
K- Pink	S- Grey
L- Light	U- Blue
N- Brown	W- White
O- Orange	Y- Yellow

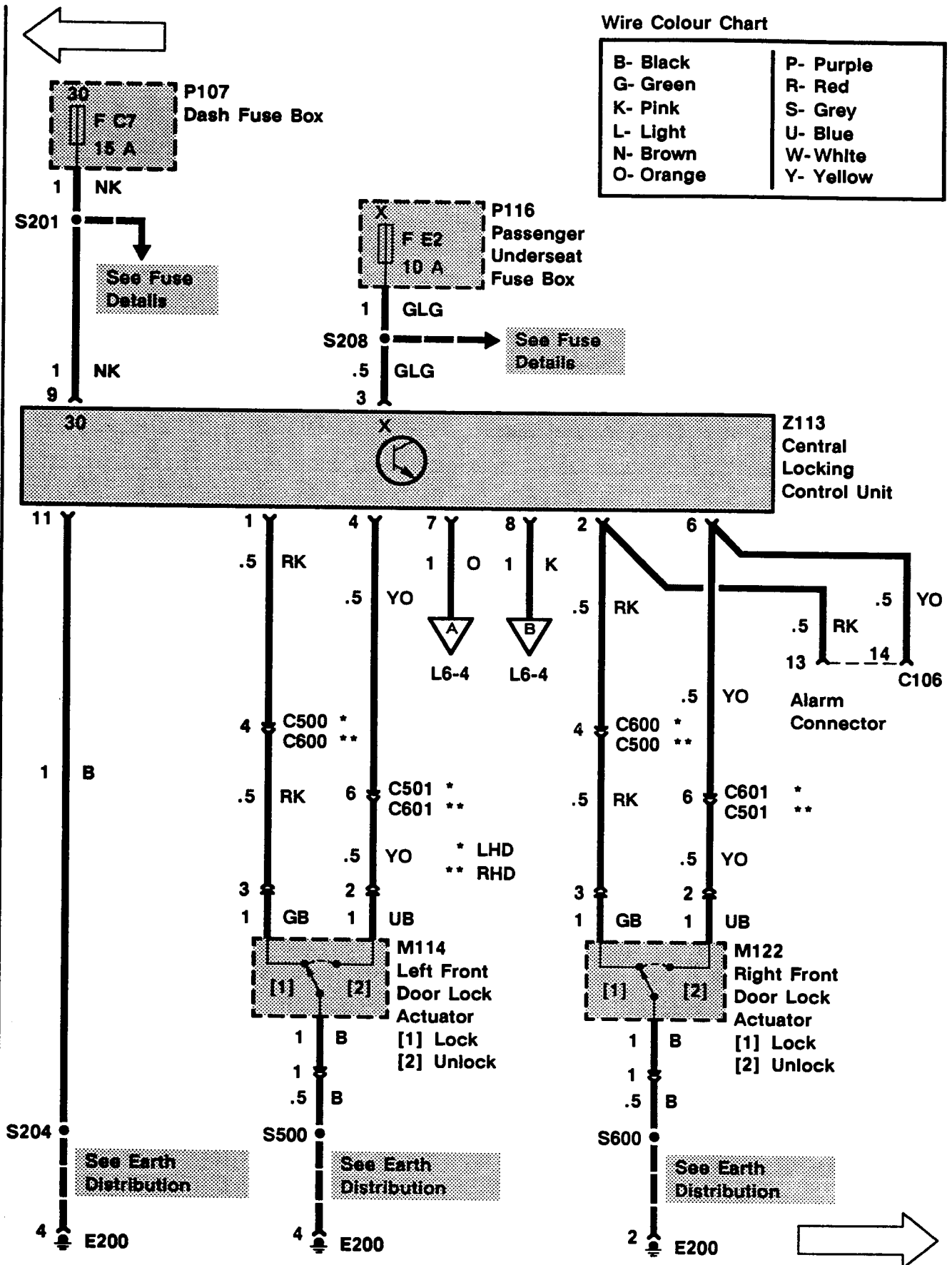

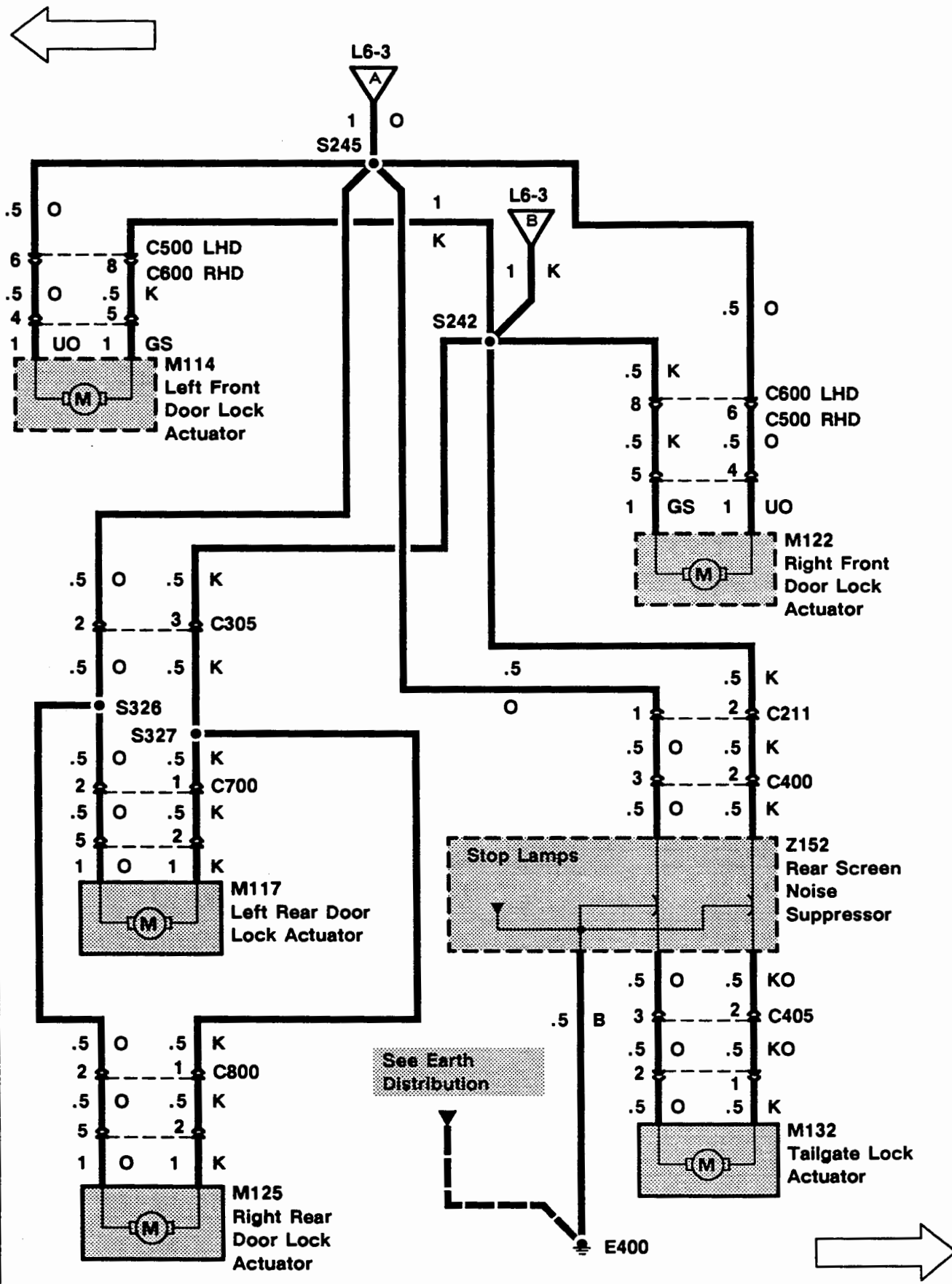

# L6 ETM

## 1992 RANGE ROVER

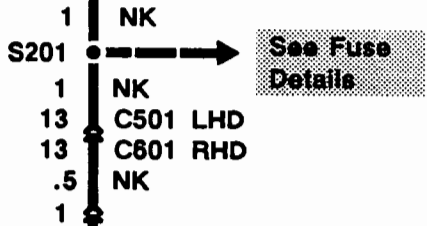
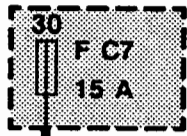
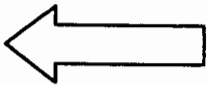

See Fuse Details

### Wire Colour Chart

B- Black	P- Purple
G- Green	R- Red
K- Pink	S- Grey
L- Light	U- Blue
N- Brown	W- White
O- Orange	Y- Yellow

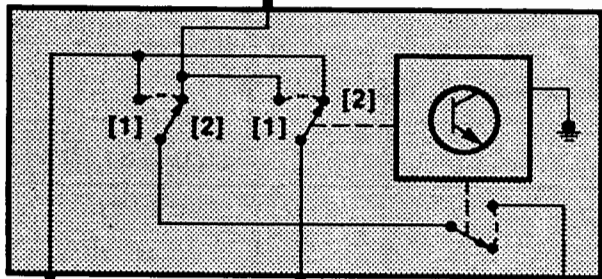

X117 Driver Door Lock Switch  
 [1] Lock  
 [2] Unlock

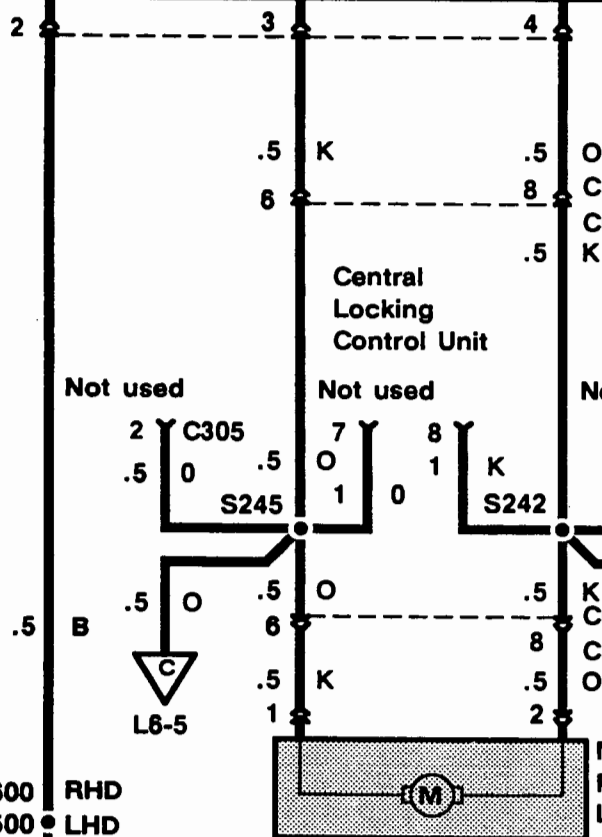
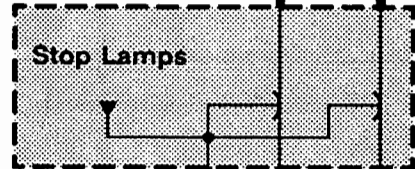
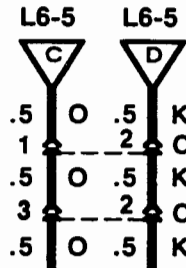

Central Locking Control Unit

Not used

Not used

Not used

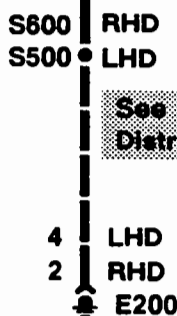

See Earth Distribution

See Earth Distribution

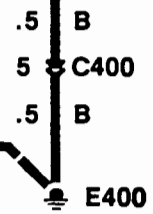

**SYSTEM DIAGNOSIS****2 Door**

1. If the Passenger Door Lock Actuator (M118) and Tailgate Lock Actuator (M132) do not lock or unlock, do Test H, the Driver Door Lock Switch (X117) test.
2. If the Passenger Door Lock Actuator (M118) does not operate but the Tailgate Lock Actuator (M132) works, do Test G.
3. If the Tailgate Lock Actuator (M132) does not work, do Test E.

**4 Door**

1. If no central locking functions work, do Test A, power and earth test
2. If a Front Door Lock Actuator (M114, M122) does not operate, do Test B.
3. If the doors relock or unlock themselves after operating the door locks, do Test C, door input short test.
4. If the central locking function does not operate from one of the front doors, do Test D, open door input test.
5. If both Rear Door Lock Actuators (M117, M125) do not operate, do Test F.
6. If the Tailgate Lock Actuator (M132) does not work, do Test E.

**Fuel Flap**

If the fuel flap does not release when operated, do Test I.

Test A

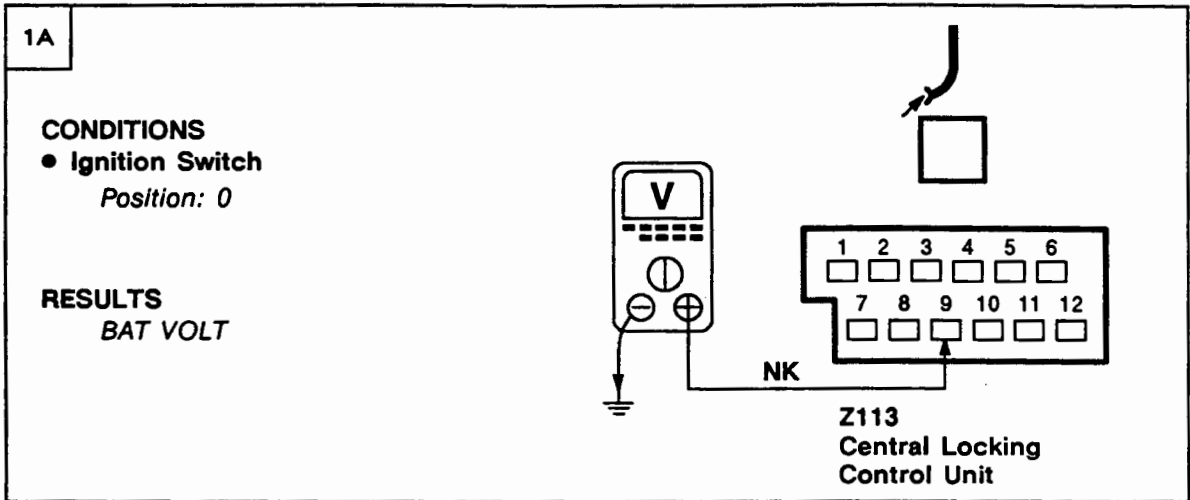

**PROBLEM CAUSE**

- F C7 Fuse
- NK Wire

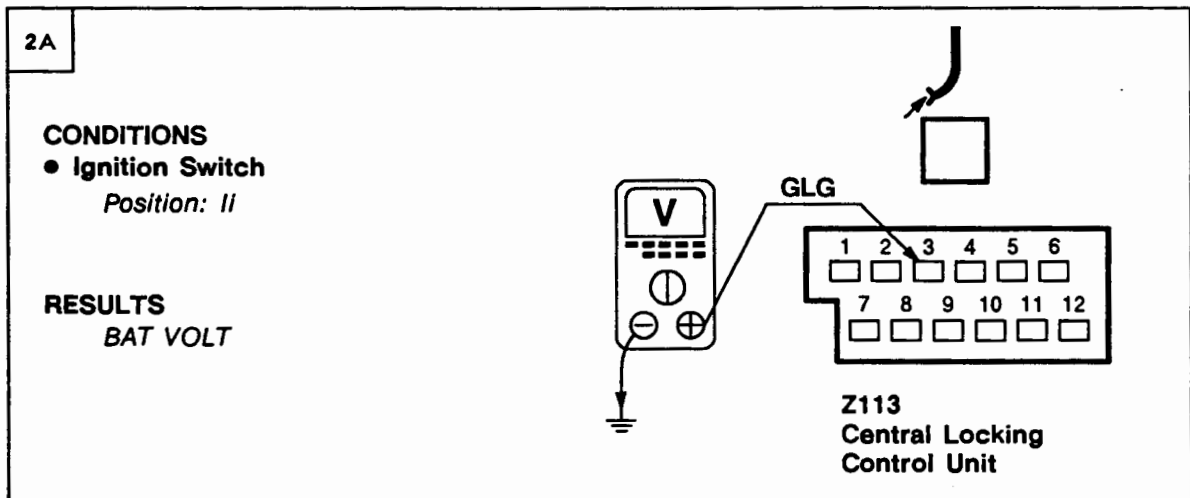

**PROBLEM CAUSE**

- F 2 Fuse
- GLG Wire



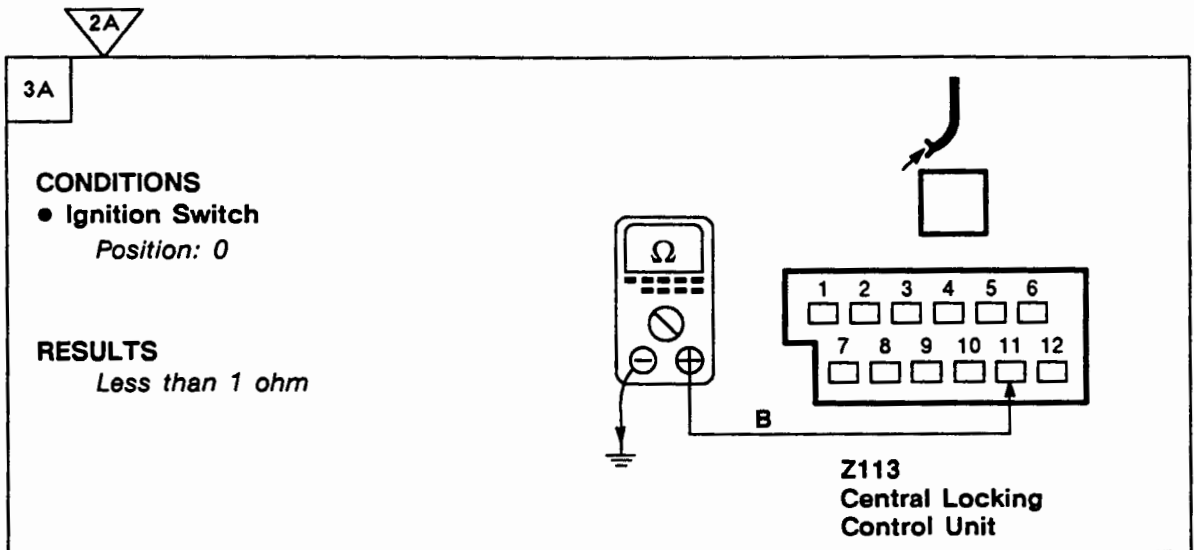

**PROBLEM CAUSE**

- B Wire
- E200

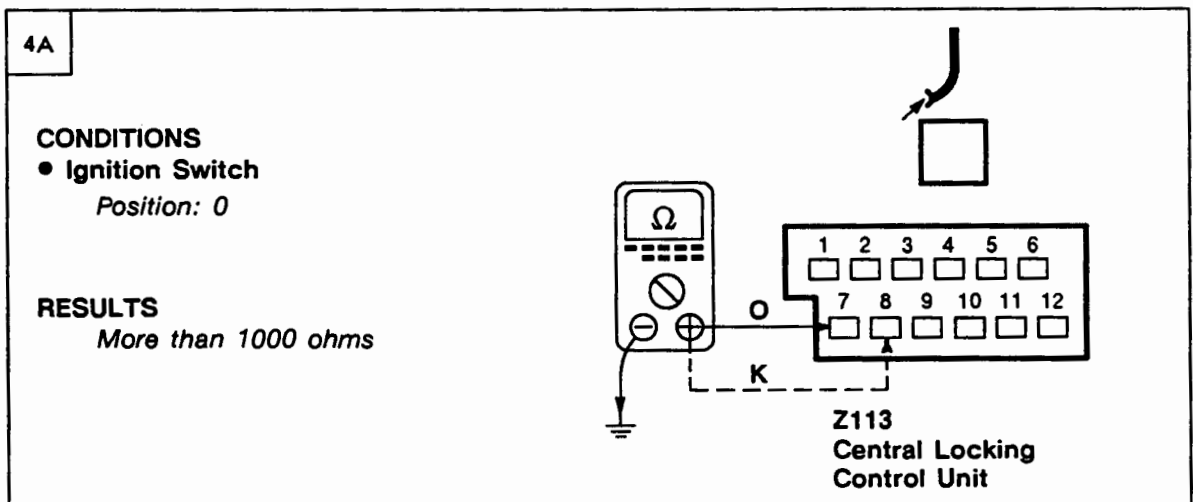

**PROBLEM CAUSE**

- O Wire
- K Wire

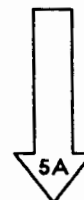

# L6 ETM

## 1992 RANGE ROVER

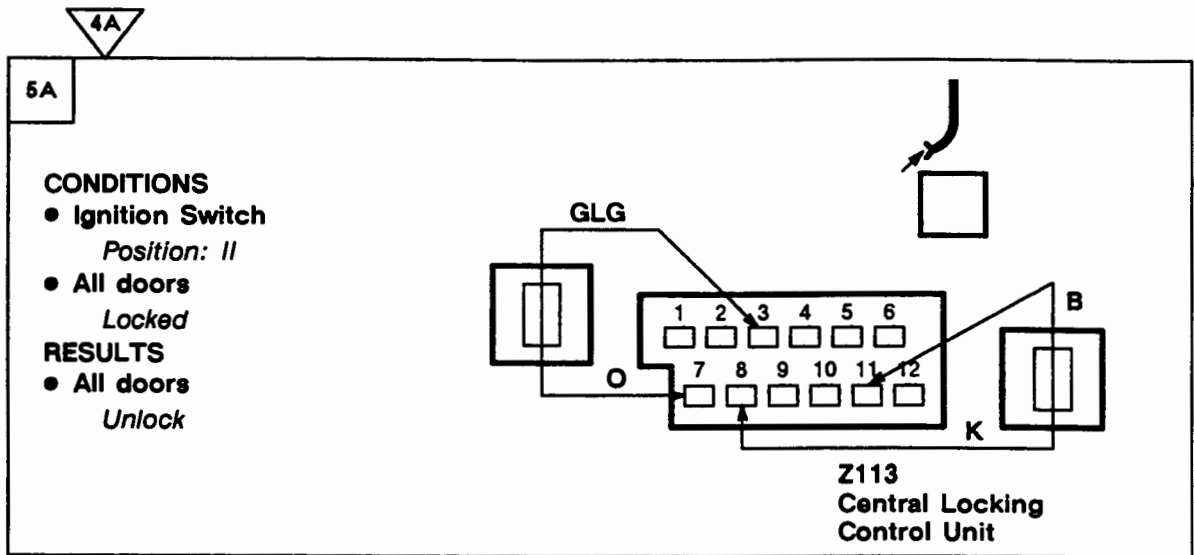

**OK** GO TO TEST B

**OK** PROBLEM CAUSE  
- Central Locking  
Control Unit

### Test B

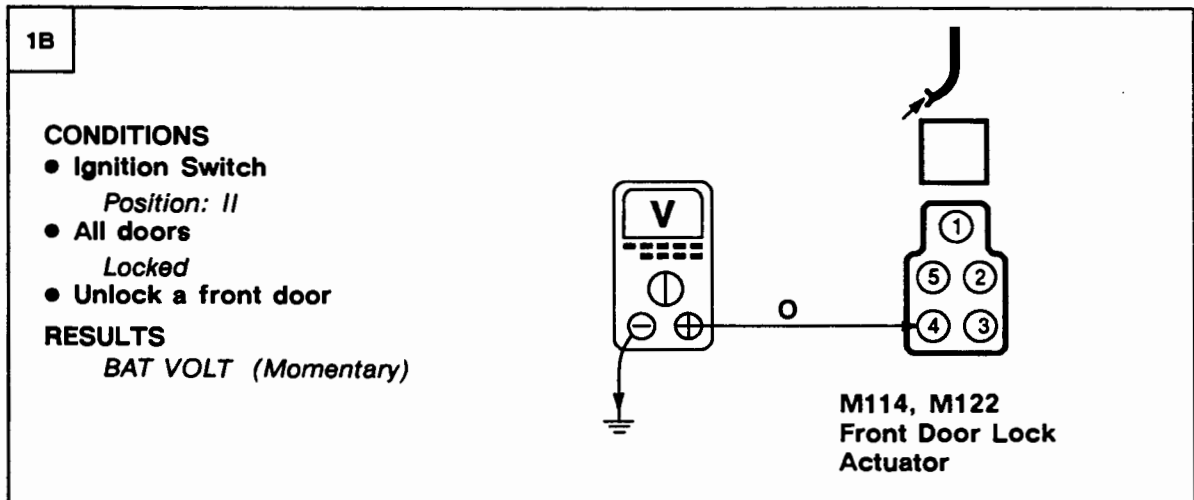

**OK** PROBLEM CAUSE  
- O Wire

**OK**

↓  
2B



1B

2B

**CONDITIONS**

- Ignition Switch  
*Position: II*
- All doors  
*Unlocked*
- Lock a front door

**RESULTS**  
*BAT VOLT (Momentary)*

M114, M122  
Front Door Lock  
Actuator

~~OK~~ PROBLEM CAUSE  
- K Wire

OK PROBLEM CAUSE  
- M114, M122 Front Door  
Lock Actuator

**Test C**

1C

**CONDITIONS**

- Ignition Switch  
*Position: 0*
- All doors  
*Unlocked*

**RESULTS**  
*More than 1000 ohms*

Z113  
Central  
Locking  
Control Unit

~~OK~~ PROBLEM CAUSE  
- RK Wire  
- M114, M122 Front Door  
Lock Actuator

OK  
↓  
2C

# L6 ETM

## 1992 RANGE ROVER

1C

2C

**CONDITIONS**

- Ignition Switch  
*Position: 0*
- All doors  
*Locked*

**RESULTS**  
*More than 1000 ohms*

**Z113**  
Central  
Locking  
Control Unit



**PROBLEM CAUSE**

- YO Wire
- M114, M122 Front Door Lock Actuator



**PROBLEM CAUSE**

- Central Locking Control Unit

### Test D

1D

**CONDITIONS**

- Ignition Switch  
*Position: 0*
- All doors  
*Locked*

**RESULTS**  
*J738*

**Z113**  
Central  
Locking  
Control Unit



GO TO TEST 3D

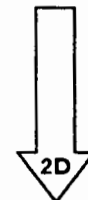

1D

2D

**CONDITIONS**

- Ignition Switch  
Position: 0
- All doors  
Unlocked

**RESULTS**

Less than 1 ohm

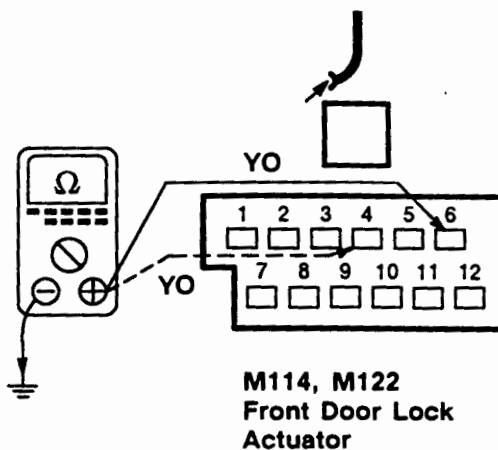

GO TO TEST E



PROBLEM CAUSE

- Central Locking Control Unit

1D

3D

**CONDITIONS**

- Ignition Switch  
Position: 0

**RESULTS**

Less than 1 ohm

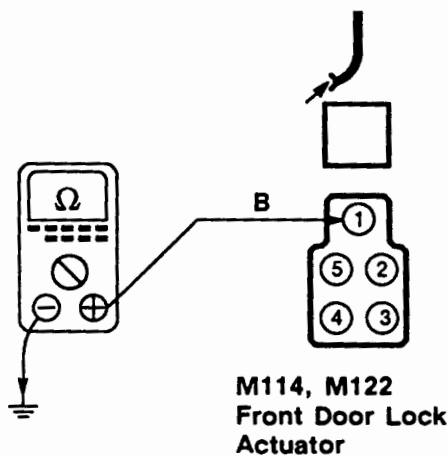

PROBLEM CAUSE

- B Wire
- E200

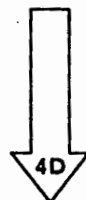

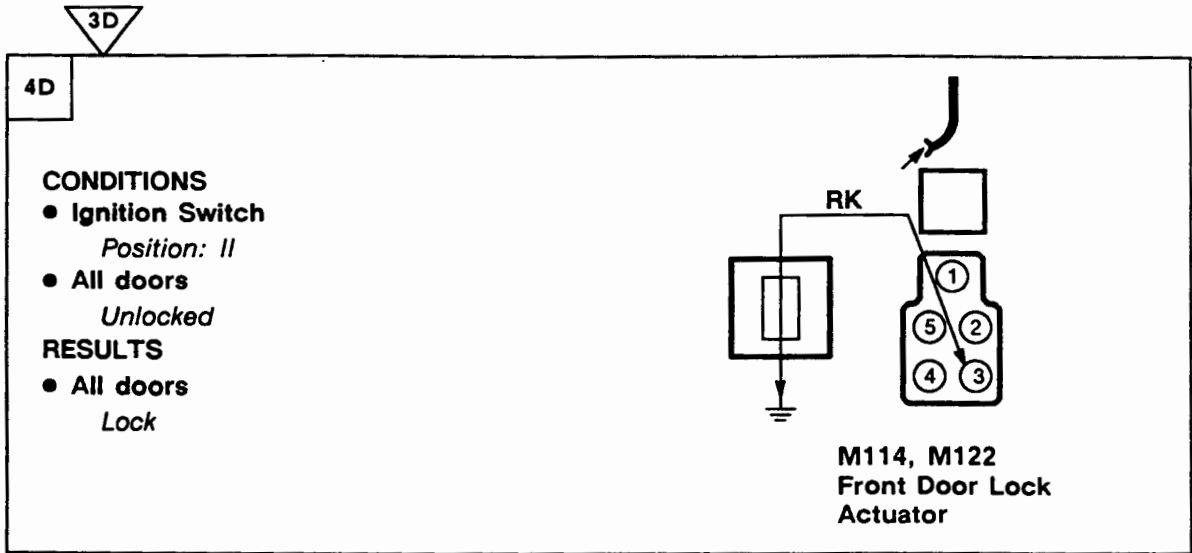

**PROBLEM CAUSE**

- RK Wire
- Central Locking Control Unit

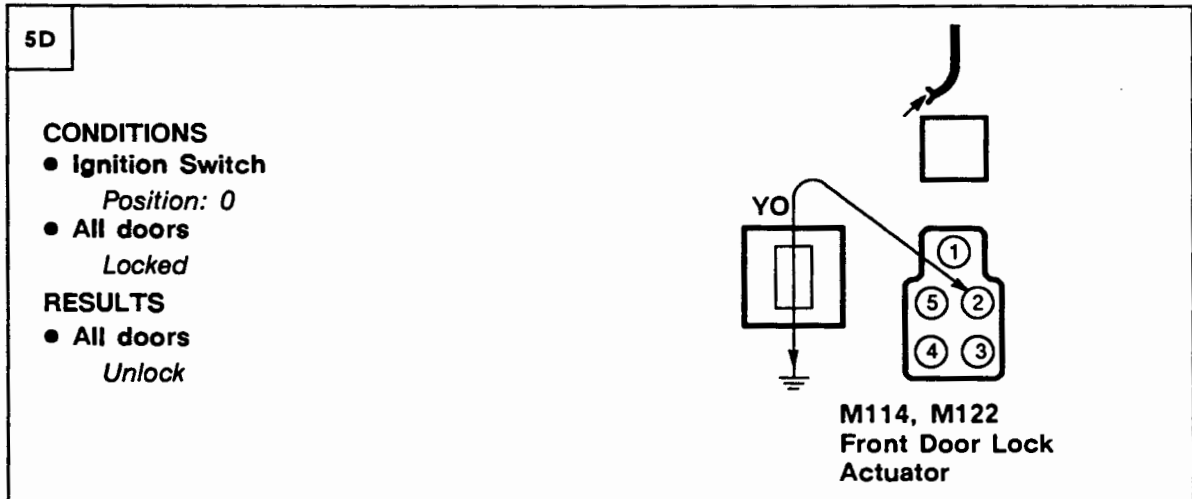

**PROBLEM CAUSE**

- YO Wire
- Central Locking Control Unit



**PROBLEM CAUSE**

- M114, M122 Front Door Lock Actuator

**Test E**

1E

**CONDITIONS**

- Ignition Switch  
*Position: 0*
- All doors  
*Unlocked*
- Lock a front door

**RESULTS**  
*BAT VOLT (Momentary)*

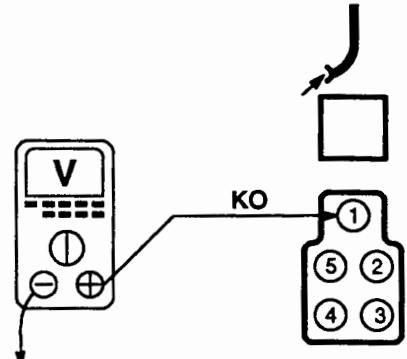

**M132  
Tailgate Lock  
Actuator**

**OK**

**PROBLEM CAUSE**

- K Wire
- KO Wire
- Rear Screen Noise Suppressor

**OK**

2E

2E

**CONDITIONS**

- Ignition Switch  
*Position: 0*
- All doors  
*Locked*
- Unlock a front door

**RESULTS**  
*BAT VOLT (Momentary)*

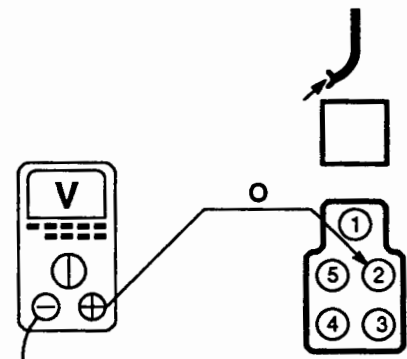

**M132  
Tailgate Lock  
Actuator**

**OK**

**PROBLEM CAUSE**

- O Wire

**OK**

**PROBLEM CAUSE**

- Tailgate Lock Actuator

Test F

**1F**

**CONDITIONS**

- Ignition Switch  
*Position: 0*
- All doors  
*Unlocked*
- Lock a front door

**RESULTS**  
*BAT VOLT (Momentary)*

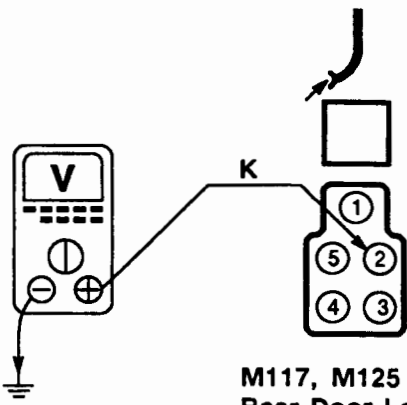

M117, M125  
Rear Door Lock  
Actuator

**OK** PROBLEM CAUSE  
- K Wire

**OK**



**2F**

**CONDITIONS**

- Ignition Switch  
*Position: 0*
- All doors  
*Locked*
- Unlock a front door

**RESULTS**  
*BAT VOLT (Momentary)*

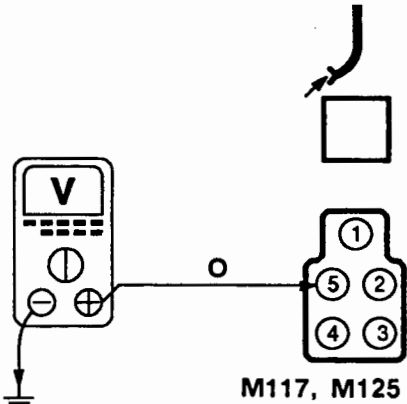

M117, M125  
Rear Door Lock  
Actuator

**OK** PROBLEM CAUSE  
- O Wire

**OK** PROBLEM CAUSE  
- M117, M125 Rear Door  
Lock Actuator

Test G

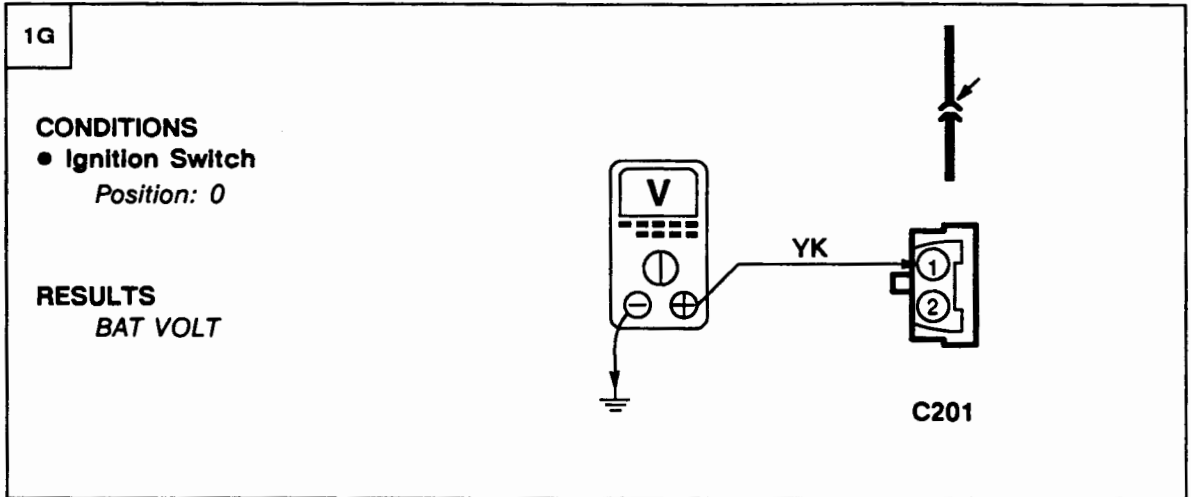

PROBLEM CAUSE

- F C6 Fuse
- YK Wire

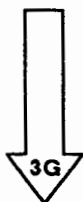
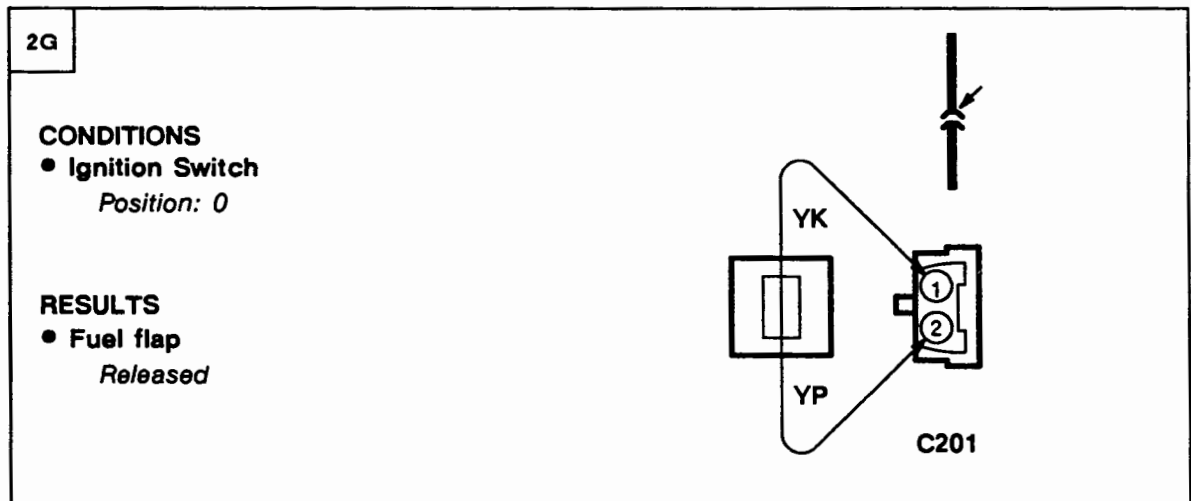
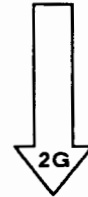

PROBLEM CAUSE

- Fuel Flap Release Switch

2G

3G

**CONDITIONS**

- Ignition Switch  
*Position: 0*

**RESULTS**  
*Less than 1 ohm*

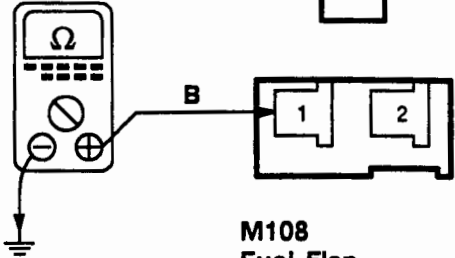

**M108  
Fuel Flap  
Actuator**

~~OK~~ **PROBLEM CAUSE**

- B Wire
- E402

OK



4G

4G

**CONDITIONS**

- Ignition Switch  
*Position: 0*
- Fuel Flap Release Switch  
*Depressed*

**RESULTS**  
*BAT VOLT*

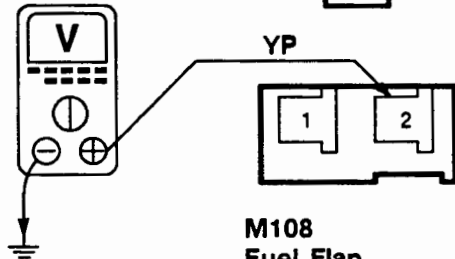

**M108  
Fuel Flap  
Actuator**

~~OK~~ **PROBLEM CAUSE**

- YP Wire

OK **PROBLEM CAUSE**

- Fuel Flap Actuator



Test H

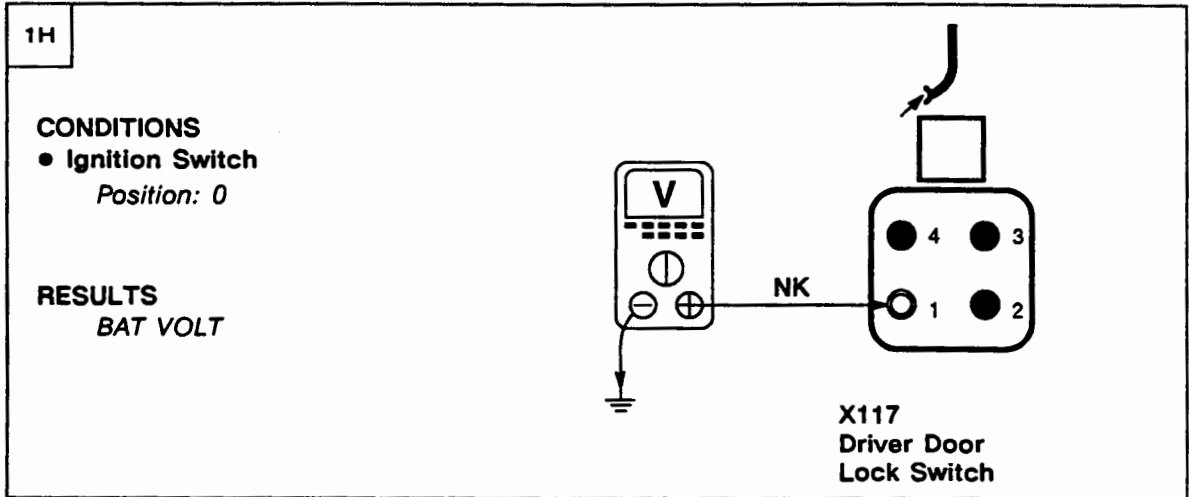

PROBLEM CAUSE

- F C7 Fuse
- NK Wire

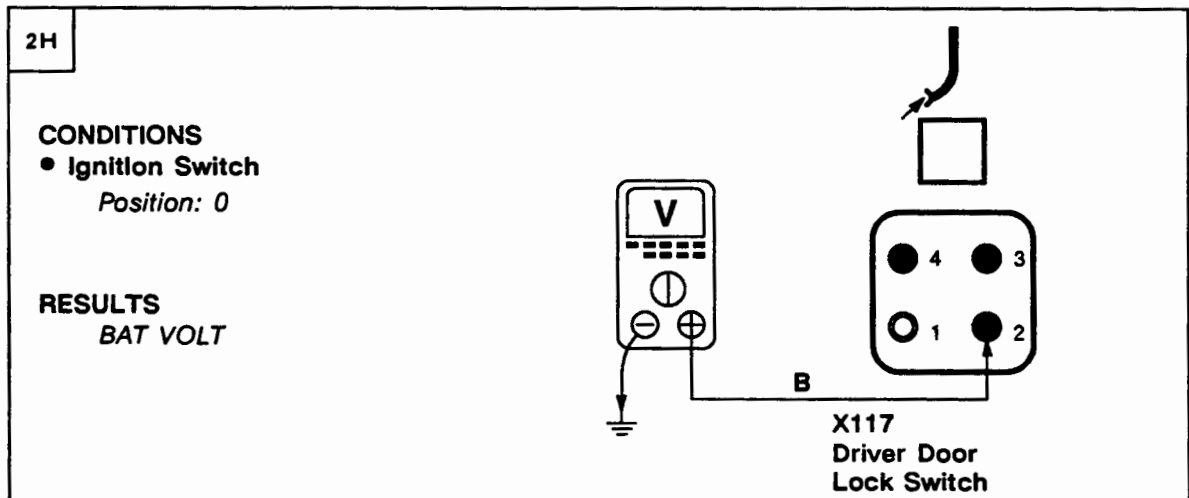
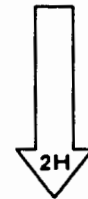

PROBLEM CAUSE

- B Wire
- E200



**L6 ETM**

**1992 RANGE ROVER**

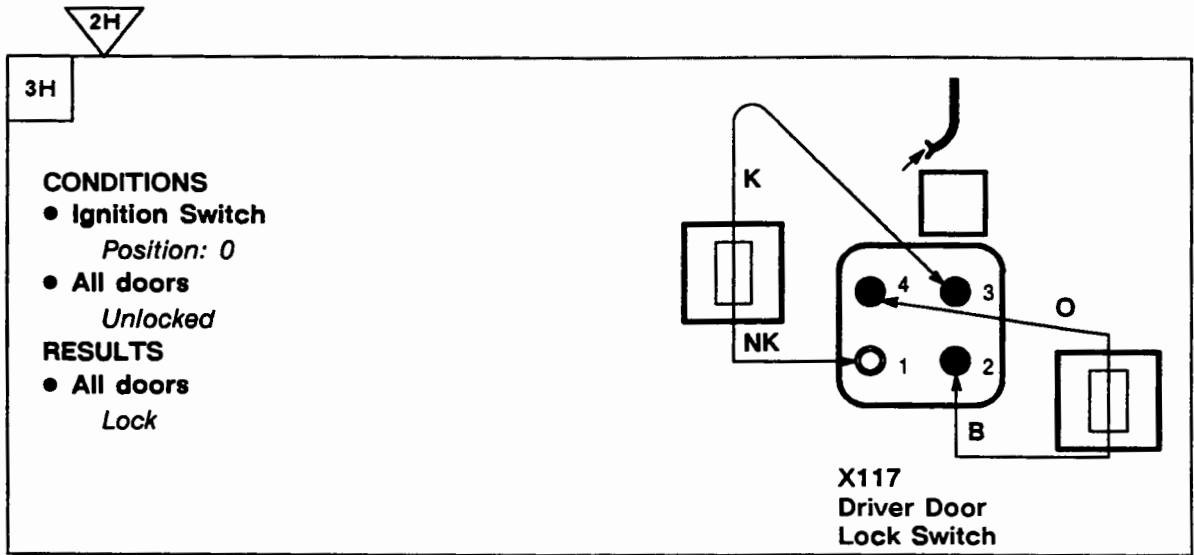

**PROBLEM CAUSE**  
- Driver Door Lock Switch

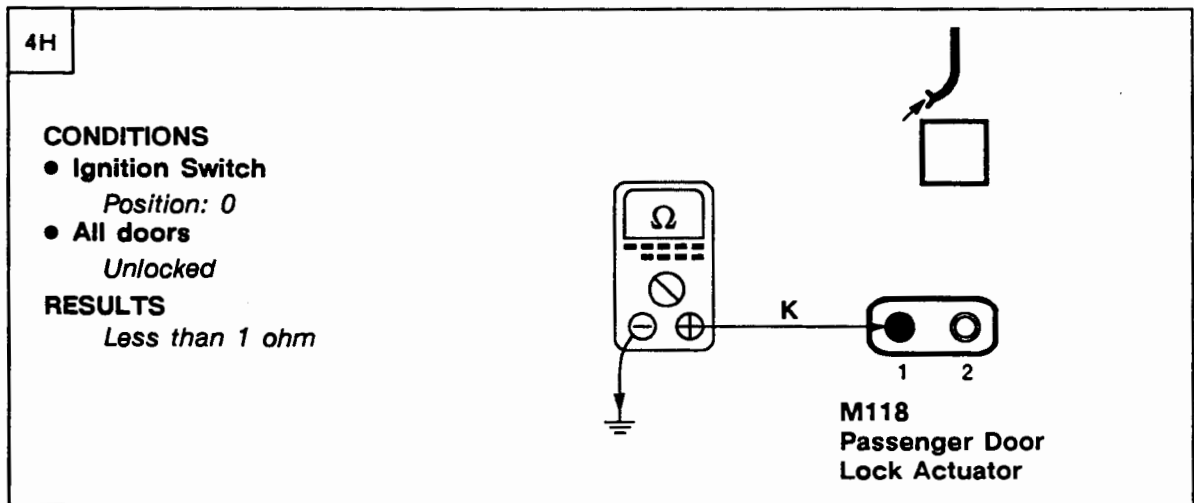

**PROBLEM CAUSE**  
- K Wire



**PROBLEM CAUSE**  
- K Wire

Test I

11

**CONDITIONS**

- Ignition Switch  
*Position: 0*
- All doors  
*Unlocked*
- Lock driver's door

**RESULTS**  
BAT VOLT (Momentary)

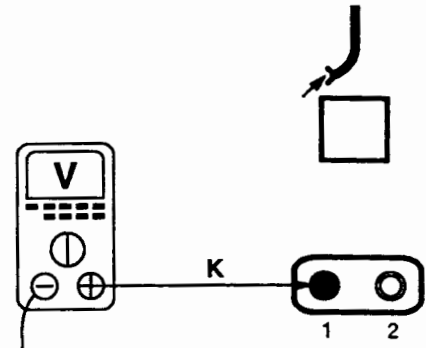

**M118**  
Passenger Door  
Lock Actuator

~~OK~~ PROBLEM CAUSE  
- K Wire

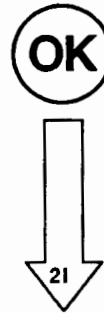

21

**CONDITIONS**

- Ignition Switch  
*Position: 0*
- All doors  
*Locked*
- Unlock driver's door

**RESULTS**  
BAT VOLT (Momentary)

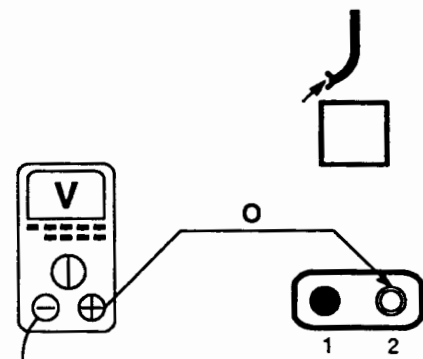

**M118**  
Passenger Door  
Lock Actuator

~~OK~~ PROBLEM CAUSE  
- O Wire

OK PROBLEM CAUSE  
- Passenger Door Lock  
Actuator

# 1992 RANGE ROVER

## KEY INFORMATION

### CIRCUIT DIAGRAMS

- Circuit diagrams are arranged so that current flow is from the top of the diagram (current source) to the bottom of the diagram (earth).
- Only those components that work together in the circuit are shown. If only part of a component is used in the circuit, then only that part of the component is shown.

#### ● Remember:

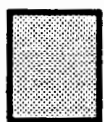

Entire component

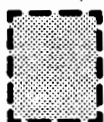

Part of a component

### TERMINAL NUMBER

50

### DESIGNATION

Battery voltage: Ignition Switch in position III

30

Battery voltage: supplied constantly

15

Battery voltage: Ignition Switch in position II or III

R

Battery voltage: Ignition Switch in positions I, II

31

Earth

See Introduction (i) for additional circuit diagram symbols.

### DIAGNOSIS

- If the diagram is accompanied by text:
  - Read the Circuit Operation before proceeding with the electrical diagnosis.
  - Read the Troubleshooting Hints before performing the System Diagnosis.
  - Tests follow the System Diagnosis.
  - When performing the System Diagnosis, be certain that all components disconnected in previous steps are reconnected unless otherwise directed.



Component is disconnected.  
Backprobe harness connector



Component is connected.  
Backprobe harness connector



Component is disconnected.  
Probe component



Component is disconnected.  
Probe harness connector



Probe in-line connector



# 1992 RANGE ROVER

## KEY INFORMATION

### CIRCUIT DIAGRAMS

- Circuit diagrams are arranged so that current flow is from the top of the diagram (current source) to the bottom of the diagram (earth).
- Only those components that work together in the circuit are shown. If only part of a component is used in the circuit, then only that part of the component is shown.
- Remember:

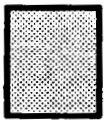

Entire component

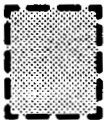

Part of a component

### TERMINAL NUMBER

50

### DESIGNATION

Battery voltage: Ignition Switch in position III

30

Battery voltage: supplied constantly

15

Battery voltage: Ignition Switch in position II or III

R

Battery voltage: Ignition Switch in positions I, II

31

Earth

See Introduction (i) for additional circuit diagram symbols.

### DIAGNOSIS

- If the diagram is accompanied by text:
  - Read the Circuit Operation before proceeding with the electrical diagnosis.
  - Read the Troubleshooting Hints before performing the System Diagnosis.
  - Tests follow the System Diagnosis.
- When performing the System Diagnosis, be certain that all components disconnected in previous steps are reconnected unless otherwise directed.



Component is disconnected.  
Backprobe harness connector



Component is connected.  
Backprobe harness connector



Component is disconnected.  
Probe component



Component is disconnected.  
Probe harness connector



Probe in-line connector