

CIRCUIT OPERATION**Driver Seat**

When the Ignition Switch (X134) is in position I or II, the Passenger Seat Relay (K131) applies earth to the Driver Seat Relay (K113). Earth is also applied to this relay when the driver's door is open. This allows the driver's seat to be adjusted with the door open. When the Driver Seat Relay (K113) is energized, battery voltage is applied to the Driver Seat Control Switch (X121). This switch is connected directly to earth. The Driver Seat Control Switch controls 4 seat control motors via 4 double-contact switches. When each switch is moved to operate its corresponding motor, 1 seat switch contact applies earth while the other applies battery voltage to the respective seat motor. The motor turns to adjust the seat in the requested direction.

Passenger Seat

Battery voltage is applied to the Passenger Seat Control Switch (X152) at all times. When the Ignition Switch (X134) is in position I or II, the Passenger Seat Relay (K131) is energized, applying earth to the Passenger Seat Control Switch. The Passenger Seat Control Switch operates like the Driver Seat Control Switch (X121).

Wire Colour Chart

B- Black	P- Purple
G- Green	R- Red
K- Pink	S- Grey
L- Light	U- Blue
N- Brown	W- White
O- Orange	Y- Yellow

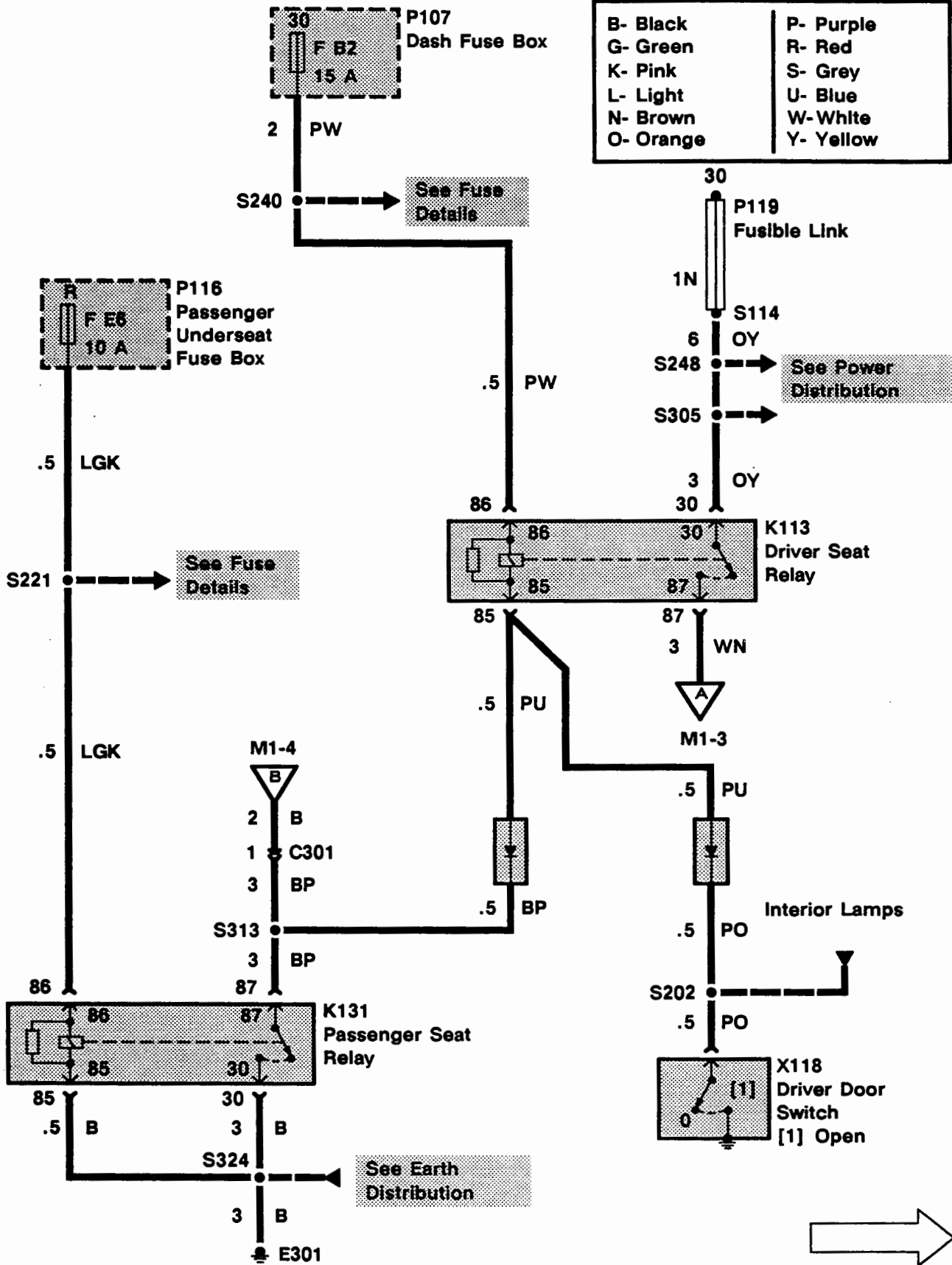

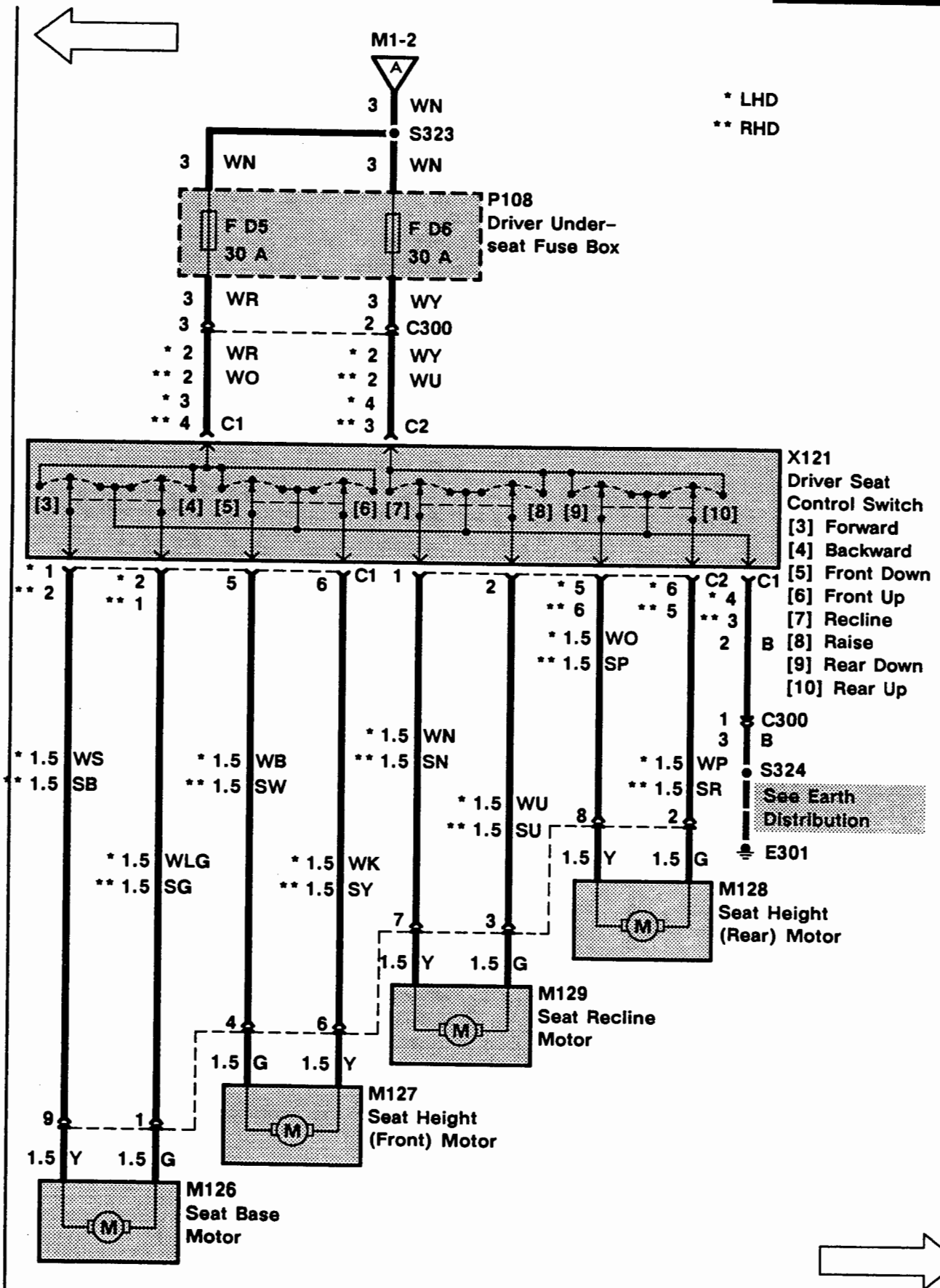

M1 ETM

1992 RANGE ROVER

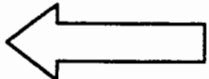

Wire Colour Chart

B- Black	P- Purple
G- Green	R- Red
K- Pink	S- Grey
L- Light	U- Blue
N- Brown	W- White
O- Orange	Y- Yellow

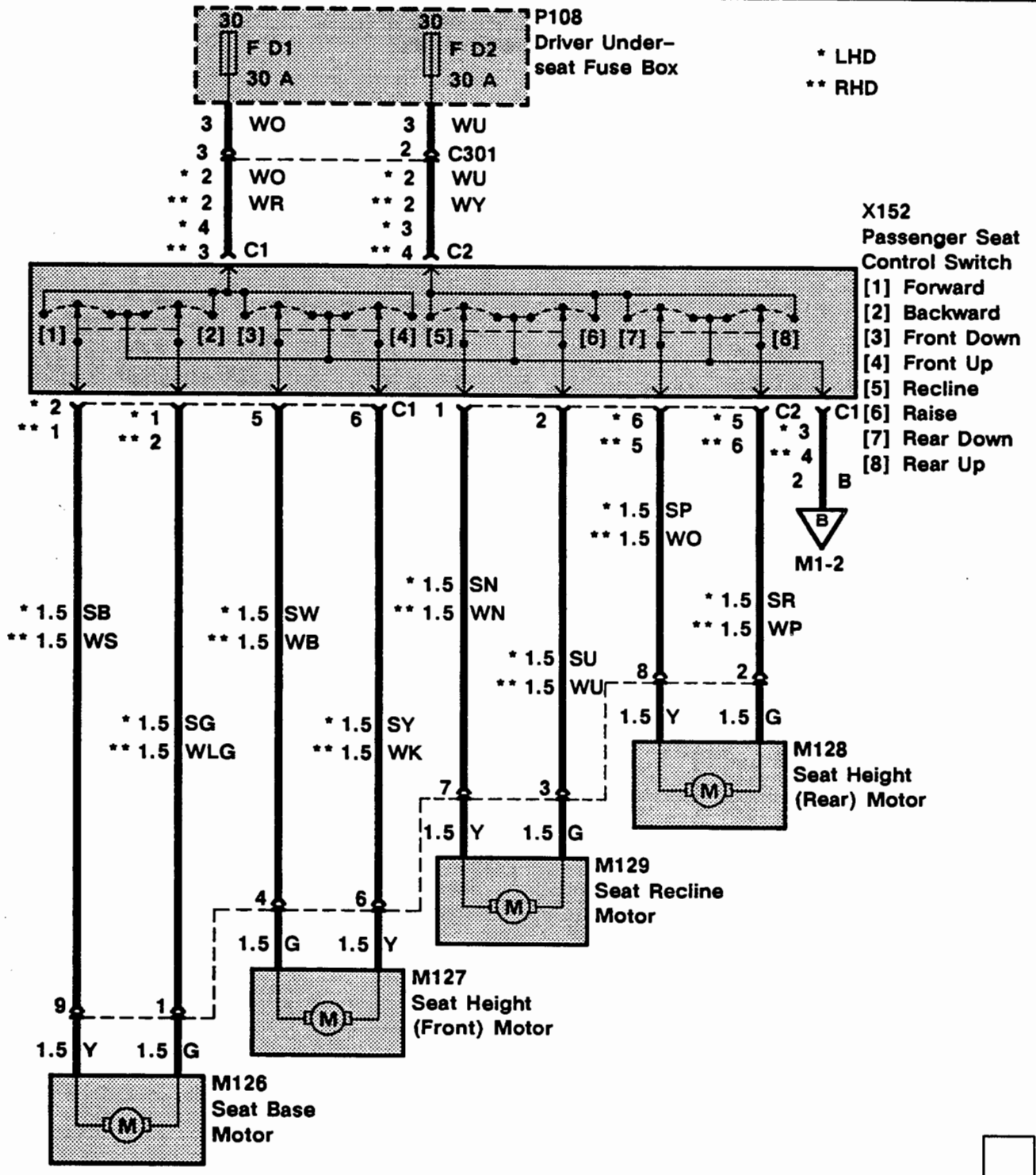

TROUBLESHOOTING HINTS

1. If the driver's seat does not operate only when the driver door is open, check the PU wire, PO wire, driver power seat diode and Driver Door Switch (X118).
2. If the passenger's seat is OK but the driver's seat operates only when the driver's door is open, check the PU wire, B wire and driver power seat diode.

SYSTEM DIAGNOSIS

1. If the driver's power seat does not move in any direction, do Test A.
2. If the passenger's power seat does not move in any direction but the driver's seat is OK, do Test C (left side) or Test E (right side).
3. If some, but not all, of the left power seat functions operate, do Test G.
4. If some, but not all, of the right power seat functions operate, do Test H.
5. If neither power seat operates when the driver's door is closed, do Test F.

M1 ETM

1992 RANGE ROVER

Test A

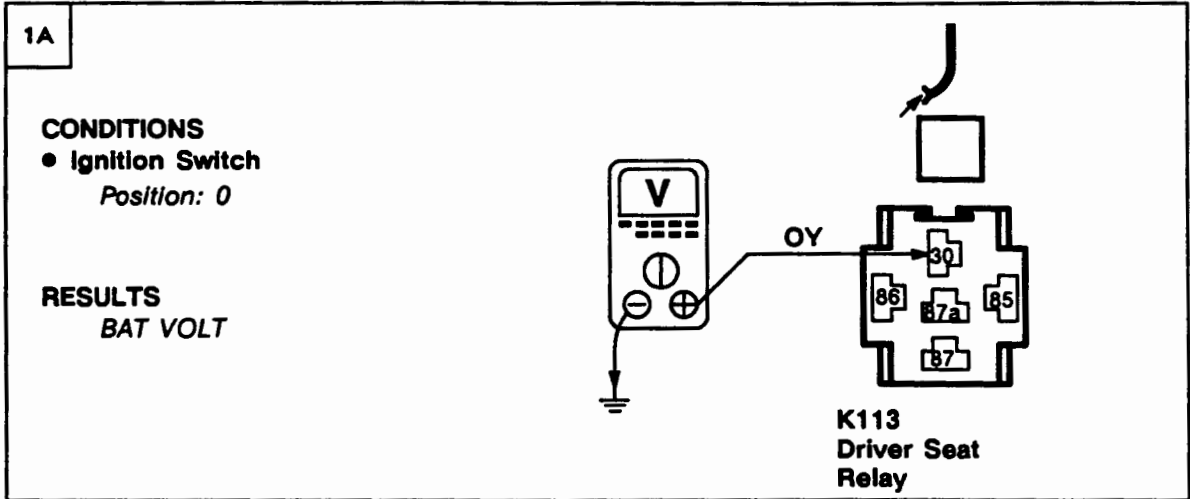

PROBLEM CAUSE

- OY Wire
- Fusible Link

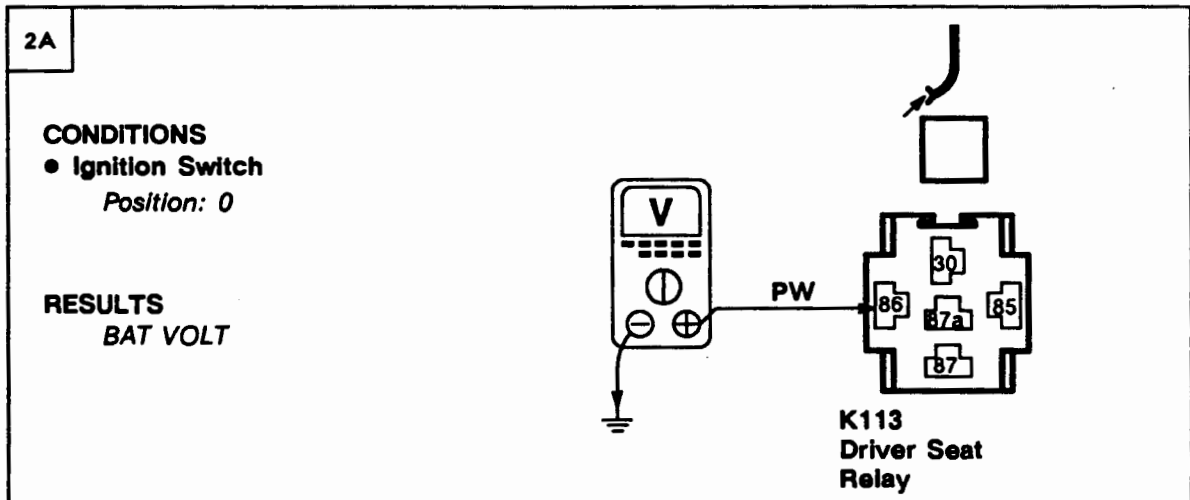
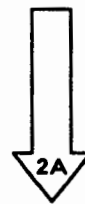

PROBLEM CAUSE

- PW Wire
- F B2 Fuse



PROBLEM CAUSE

- LHD
Go to Test B
- RHD
Go to Test D

Test D

1D

CONDITIONS

- Ignition Switch
Position: 0
- Driver's door
Open

RESULTS
BAT VOLT

X121
Driver Seat
Control Switch

- ~~OK~~

PROBLEM CAUSE

 - F E5 Fuse
 - WO Wire
 - WR Wire
 - WN Wire

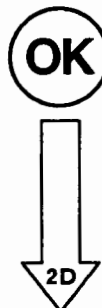

2D

CONDITIONS

- Ignition Switch
Position: 0
- Driver's door
Open

RESULTS
BAT VOLT

X121
Driver Seat
Control Switch

- ~~OK~~

PROBLEM CAUSE

 - F E6 Fuse
 - WU Wire
 - WY Wire
 - WN Wire

- OK

PROBLEM CAUSE

 - B Wire
 - Seat motors connector
 - Driver Seat Control Switch

Test E

1E

CONDITIONS
 • Ignition Switch
 Position: 0

RESULTS
 BAT VOLT

X152 Passenger Seat Control Switch



PROBLEM CAUSE

- F D1 Fuse
- WR Wire
- WO Wire



2E

CONDITIONS
 • Ignition Switch
 Position: 0

RESULTS
 BAT VOLT

X152 Passenger Seat Control Switch



PROBLEM CAUSE

- F D2 Fuse
- WY Wire
- WU Wire



PROBLEM CAUSE

- B Wire
- BP Wire
- Seat motors connector
- Passenger Seat Control Switch

Test F

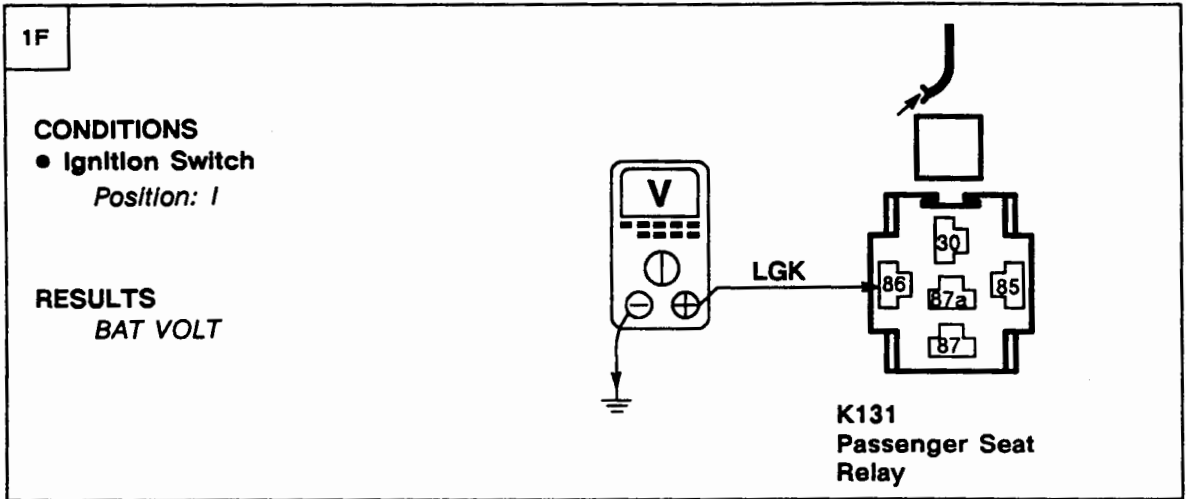

~~OK~~ **PROBLEM CAUSE**
 - F E6 Fuse
 - LGK Wire

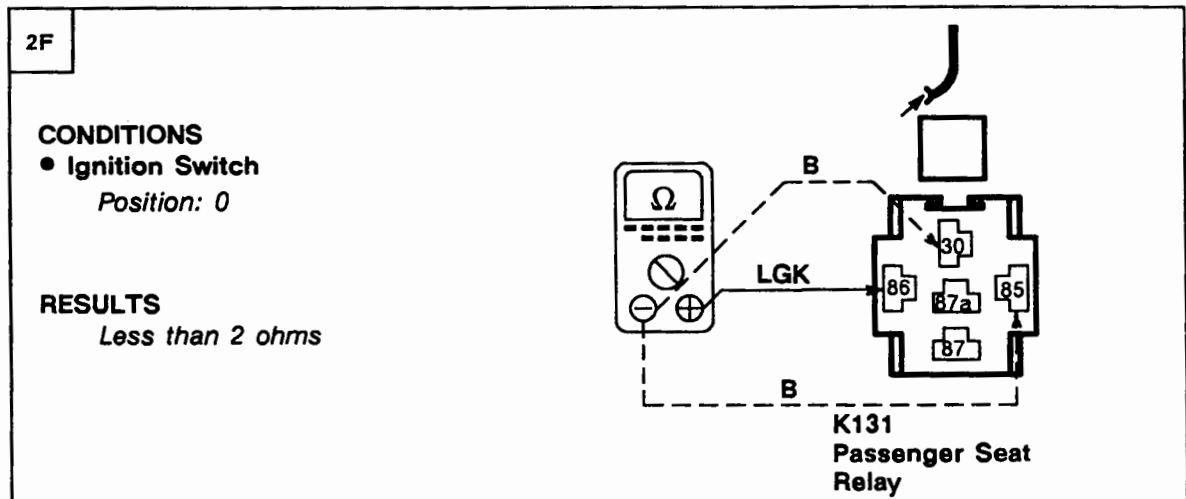
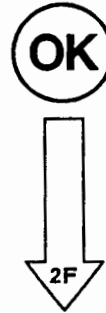

~~OK~~ **PROBLEM CAUSE**
 - B Wire

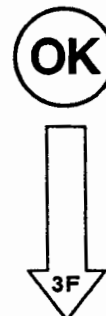

M1 ETM

1992 RANGE ROVER

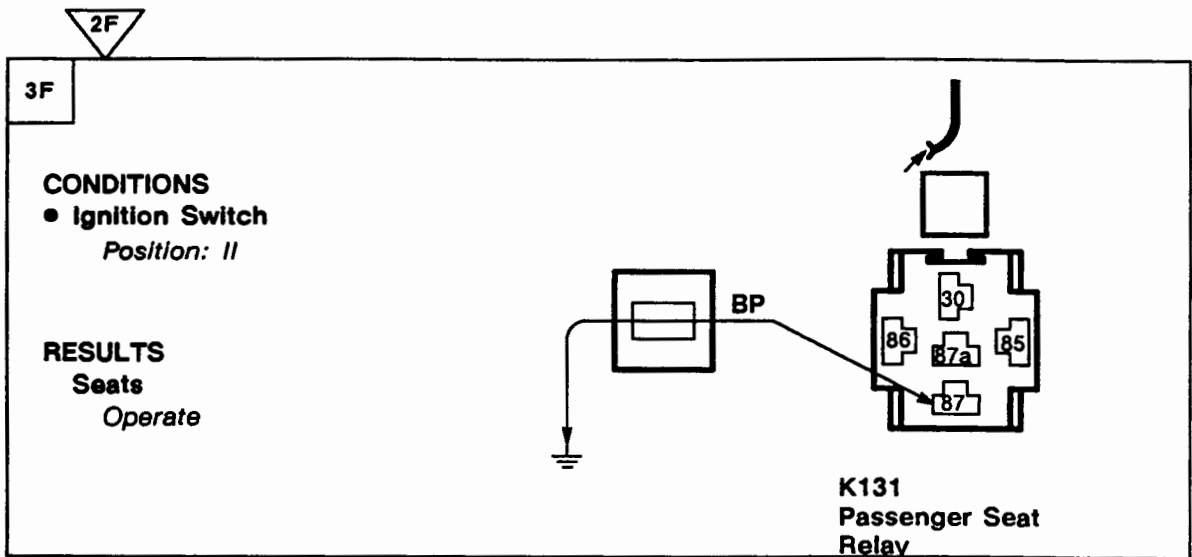

PROBLEM CAUSE
- BP Wire



PROBLEM CAUSE
- Passenger Seat Relay

Test G

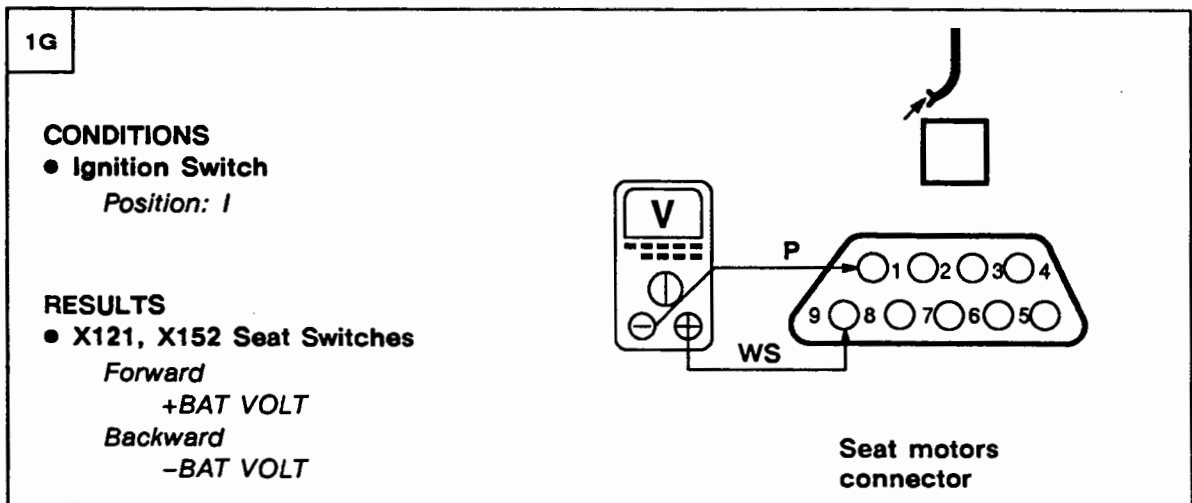

PROBLEM CAUSE
- WLG Wire
- WS Wire
- X121, X152 Seat Switches

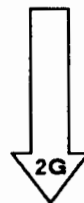

1G

2G

CONDITIONS

- Ignition Switch
Position: I

RESULTS

- X121, X152 Seat Switches

Rear up
-BAT VOLT

Rear down
+BAT VOLT

Seat motors connector

- ~~OK~~ PROBLEM CAUSE
- WP Wire
 - WO Wire
 - X121, X152 Seat Switches

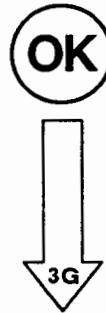

3G

CONDITIONS

- Ignition Switch
Position: I

RESULTS

- X121, X152 Seat Switches

Recline
+BAT VOLT

Raise
-BAT VOLT

Seat motors connector

- ~~OK~~ PROBLEM CAUSE
- WU Wire
 - WN Wire
 - X121, X152 Seat Switches

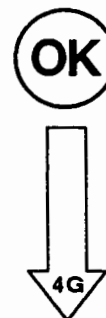

M1 ETM

1992 RANGE ROVER

3G

4G

CONDITIONS

- Ignition Switch
Position: I

RESULTS

- X121, X152 Seat Switches
Front down +BAT VOLT
Front up -BAT VOLT

Seat motors connector



PROBLEM CAUSE

- WB Wire
- WK Wire
- X121, X152 Seat Switches



PROBLEM CAUSE

- Seat motors

Test H

1H

CONDITIONS

- Ignition Switch
Position: I

RESULTS

- X121, X152 Seat Switches
Forward +BAT VOLT
Backward -BAT VOLT

Seat motors connector



PROBLEM CAUSE

- SG Wire
- SB Wire
- X121, X152 Seat Switches

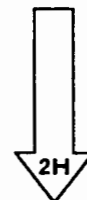

1H

2H

CONDITIONS

- Ignition Switch
Position: I

RESULTS

- X121, X152 Seat Switches

Rear up
-BAT VOLT

Rear down
+BAT VOLT

SR

SP

Seat motors connector

OK PROBLEM CAUSE

- SR Wire
- SP Wire
- X121, X152 Seat Switches

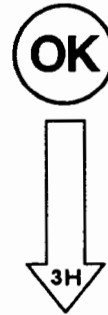

3H

CONDITIONS

- Ignition Switch
Position: I

RESULTS

- X121, X152 Seat Switches

Recline
+BAT VOLT

Raise
-BAT VOLT

SU

SN

Seat motors connector

OK PROBLEM CAUSE

- SU Wire
- SN Wire
- X121, X152 Seat Switches

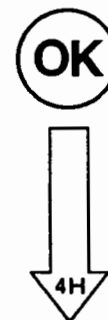

M1 ETM

1992 RANGE ROVER

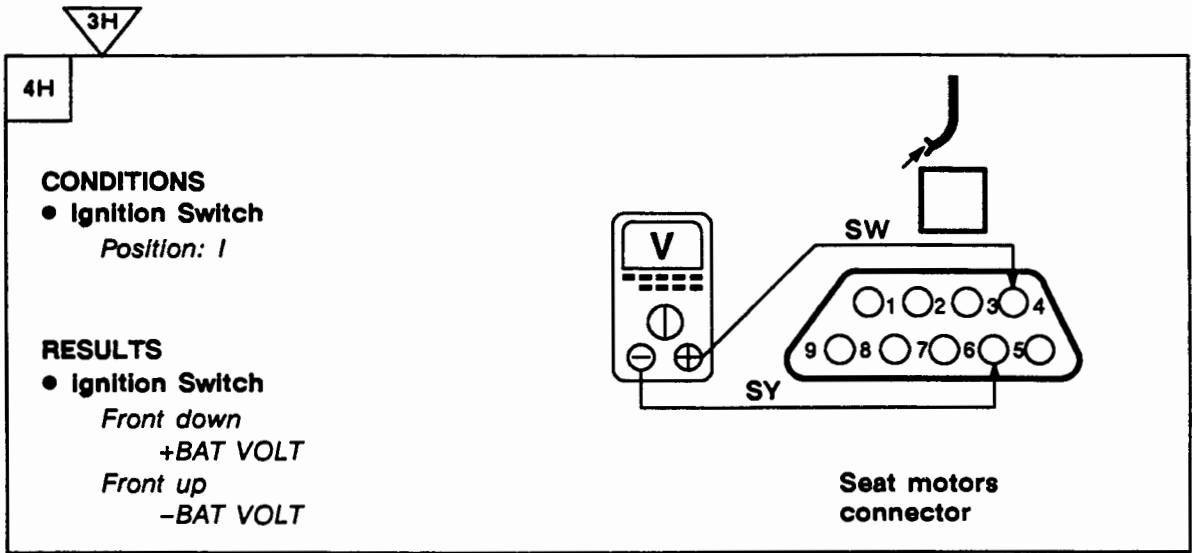

PROBLEM CAUSE

- WB Wire
- WK Wire
- X121, X152 Seat Switches



PROBLEM CAUSE

- Seat motors

ETM M2

HEATED SEATS

Wire Colour Chart

B- Black	P- Purple
G- Green	R- Red
K- Pink	S- Grey
L- Light	U- Blue
N- Brown	W- White
O- Orange	Y- Yellow

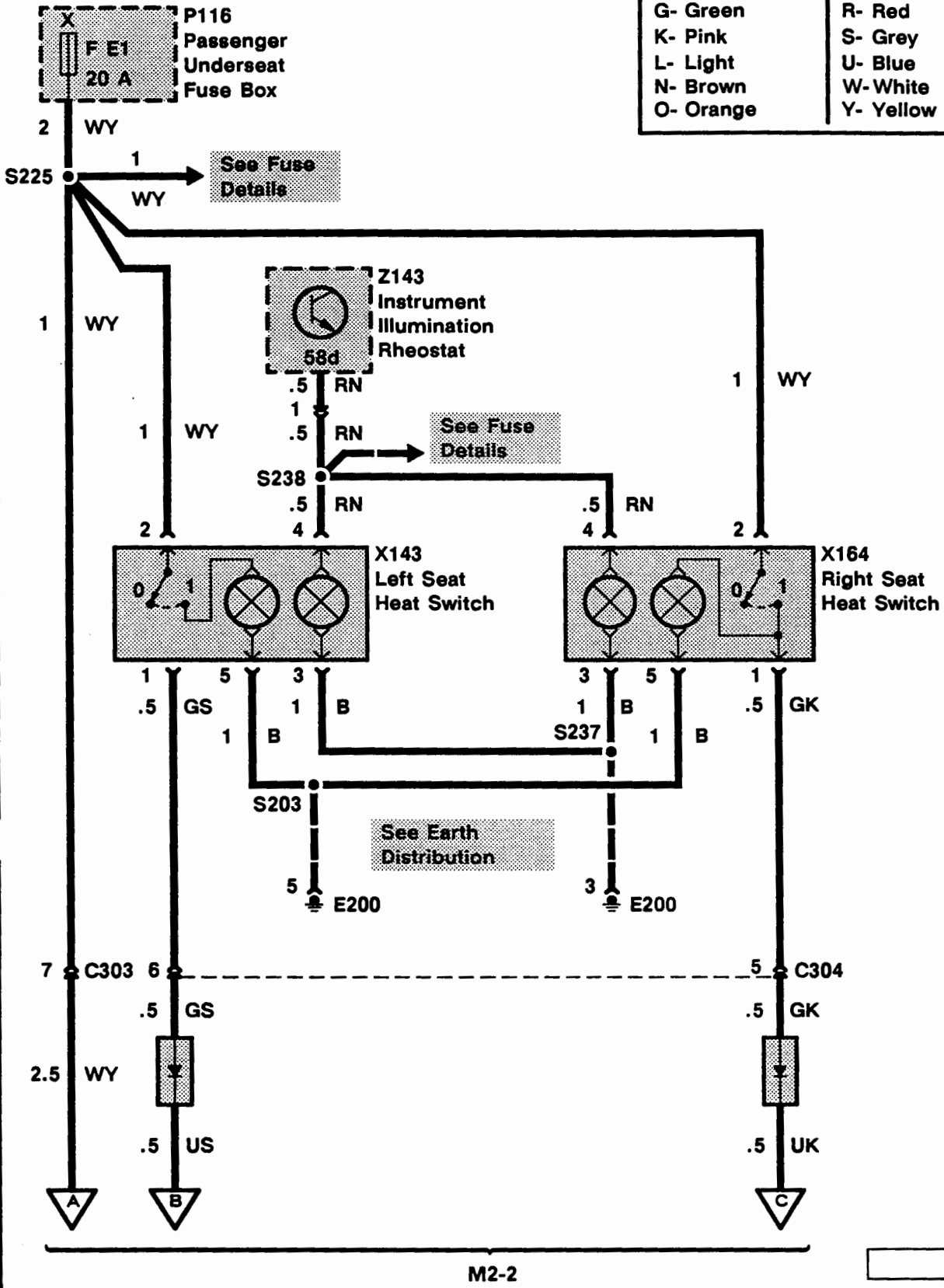

M2 ETM

1992 RANGE ROVER

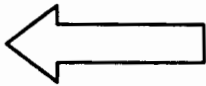

Wire Colour Chart

B- Black	P- Purple
G- Green	R- Red
K- Pink	S- Grey
L- Light	U- Blue
N- Brown	W- White
O- Orange	Y- Yellow

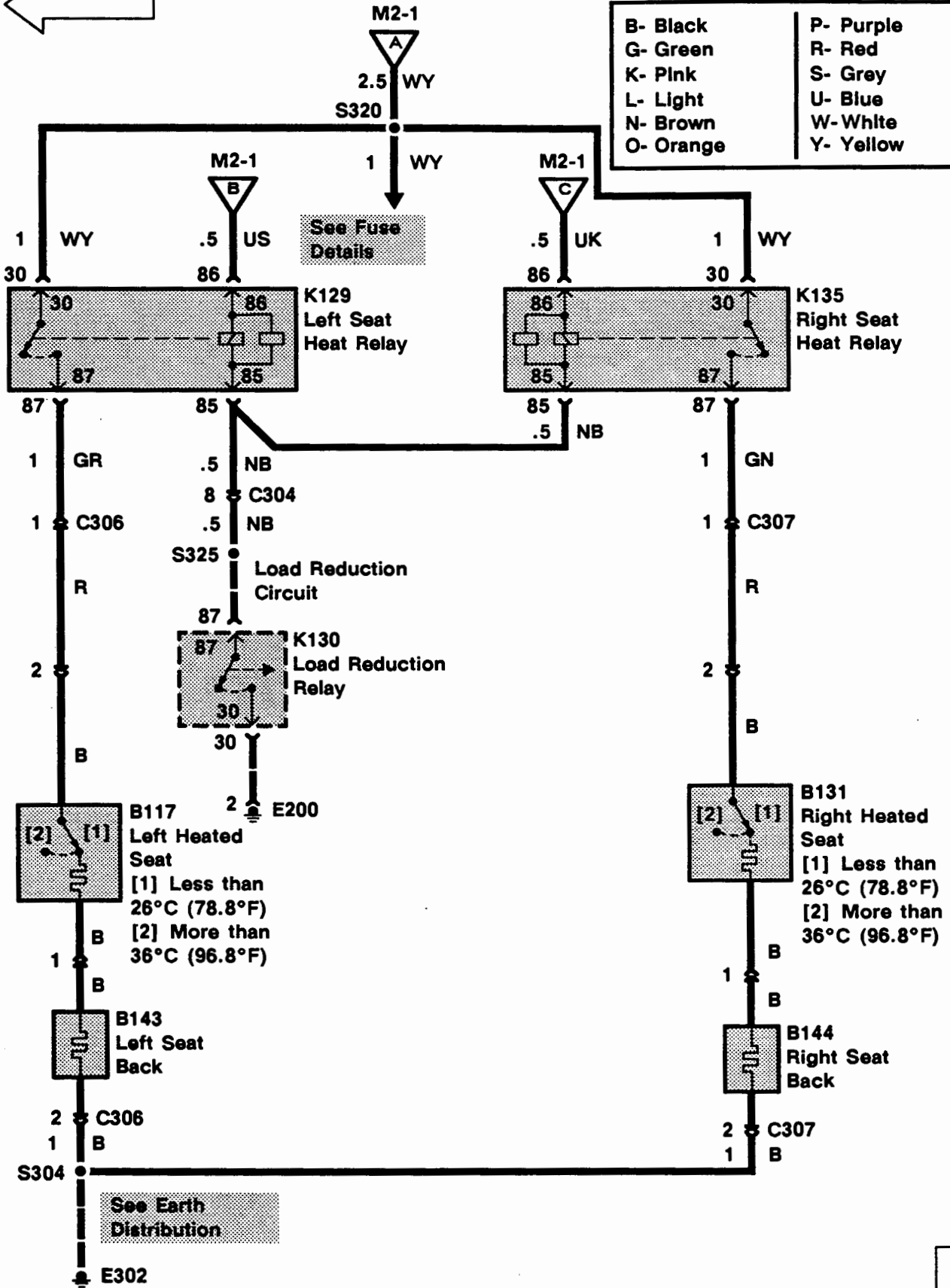

CIRCUIT OPERATION

When the Ignition Switch (X134) is in position II, voltage is supplied to the power mirrors circuit by fuse F 2.

Right/Down Movement

When the Mirror Adjustment Switch (X146) is in the RIGHT or DOWN position, voltage is applied to the selected Mirror Actuator (M115, M123) through the Mirror Adjustment Switch, the SW wire, Mirror Changeover Switch (X192) and the SR (left) or SP (right) wire. The selected Mirror Actuator is earthed at E200 through the PR wire, the SLG wire, the 'Left/Up' contacts of the Mirror Adjustment Switch and the B wire. The mirrors now move.

If the DOWN position is selected, the 'Up/Down' contacts in the Mirror Adjustment Switch close to apply voltage to a solenoid in the Mirror Actuator through the WP wire. The solenoid energizes because it is earthed at E200 through the B wire. The energized solenoid engages the motor in the actuator with the up/down gearbox.

Left/Up Movement

When the Mirror Adjustment Switch (X146) is in the LEFT/UP position, voltage is applied to the selected mirror through the Mirror Adjustment Switch and the SLG wire. The selected Mirror Actuator (M115, M123) is earthed at E200 through the PW wire, the SR (Left) or SP (Right) wire, the Mirror Changeover Switch (X192), the 'Right/Down' contacts of the Mirror Adjustment Switch and the B wire. The Mirror Actuator now runs.

When the UP position is selected, the 'up/down' contacts of the Mirror Adjustment Switch close to energize the Mirror Actuator solenoid. When the solenoid is energized, it engages the up/down gearbox.

M3 ETM

1992 RANGE ROVER

** RHD
Passenger Door

* LHD
Passenger Door

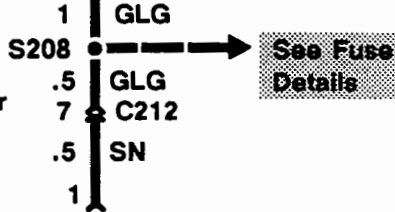

See Fuse
Details

Wire Colour Chart

B- Black	P- Purple
G- Green	R- Red
K- Pink	S- Grey
L- Light	U- Blue
N- Brown	W- White
O- Orange	Y- Yellow

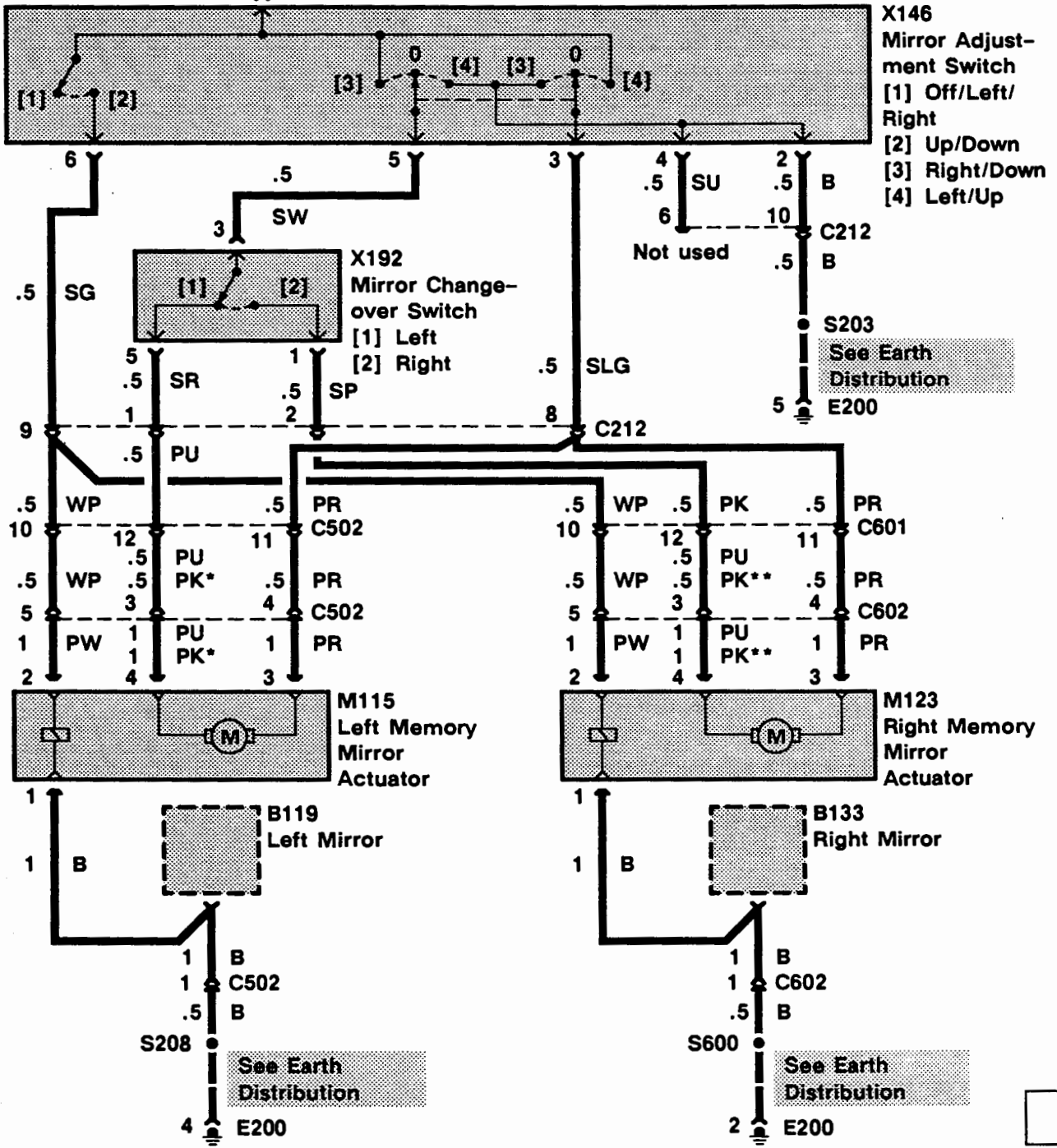

See Earth
Distribution

See Earth
Distribution

TROUBLESHOOTING HINTS

If both mirrors will not move left or right but the mirror operates up and down, replace the Mirror Adjustment Switch (X146).

SYMPTOM DIAGNOSIS

1. If the mirrors do not operate at all, do Test A.
2. If one or both mirrors will not move up or down but the mirror does move left and right, do Test B.
3. If only one mirror does not operate, do Test C, the Mirror Actuator (M115, M123) Test.

Test A

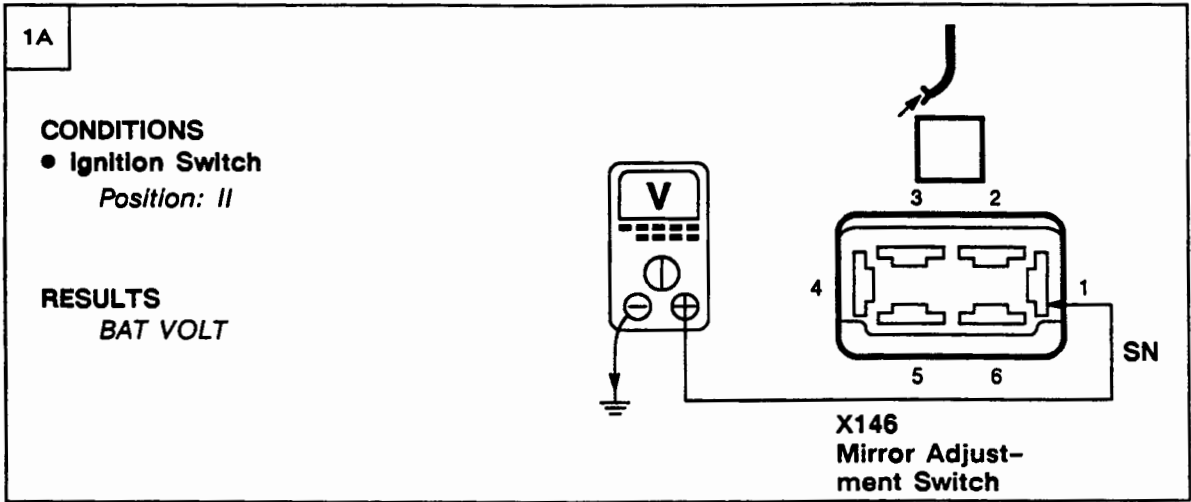

~~OK~~ **PROBLEM CAUSE**

- F 2 Fuse
- GLG Wire
- SN Wire

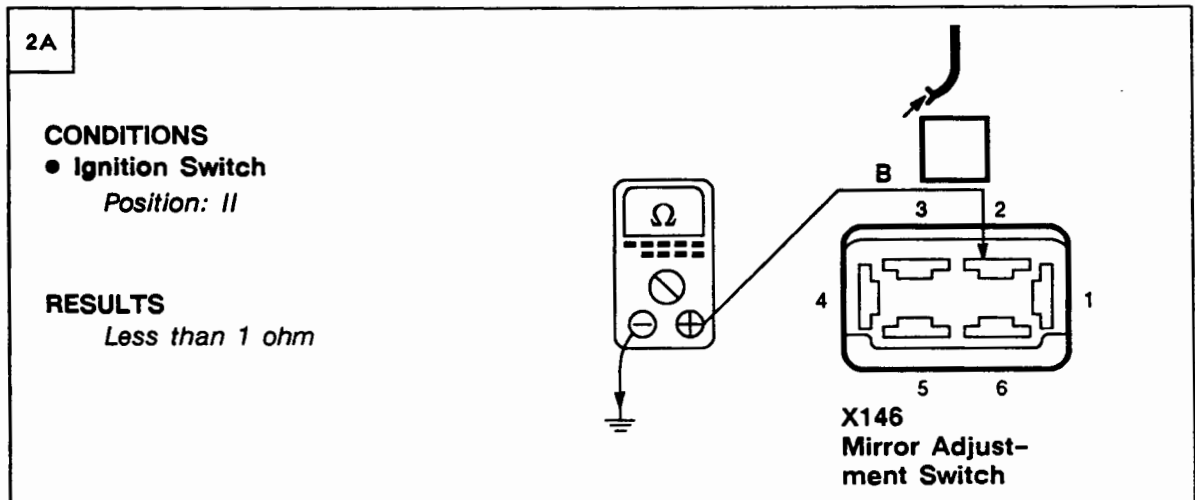
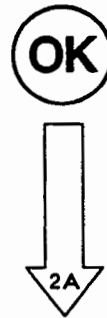

~~OK~~ **PROBLEM CAUSE**

- B Wire

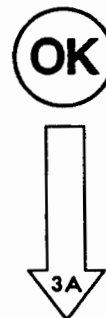

2A

3A

CONDITIONS

- Ignition Switch
Position: II

RESULTS

- Mirror Adjustment Switch
Right/Down
BAT VOLT
- Neutral*
0V

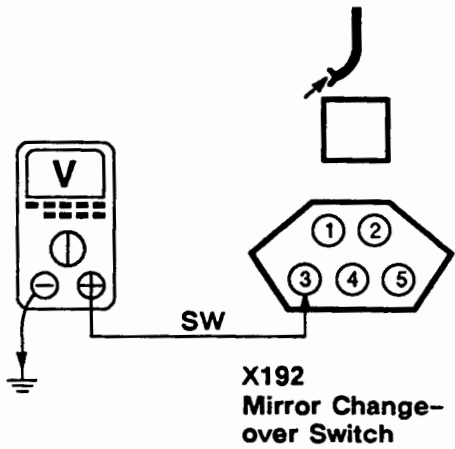

X192
Mirror Change-over Switch

OK PROBLEM CAUSE

- SW Wire
- Mirror Adjustment Switch



4A

CONDITIONS

- Ignition Switch
Position: II

RESULTS

- Mirror Adjustment Switch
Left/Up
Less than 1 ohm
- Neutral*
More than 10K ohms

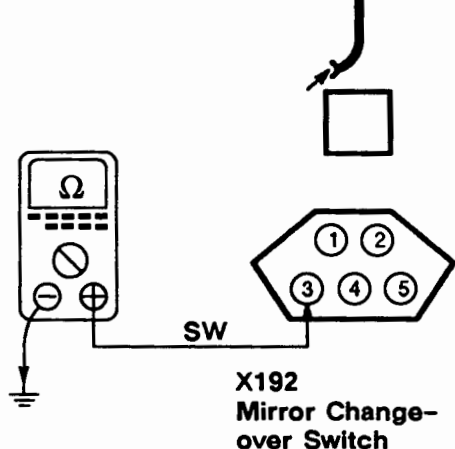

X192
Mirror Change-over Switch

OK PROBLEM CAUSE

- Mirror Adjustment Switch

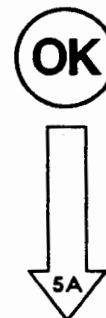

M3 ETM

1992 RANGE ROVER

4A

5A

CONDITIONS

- Ignition Switch
Position: 0

RESULTS

- Mirror Adjustment Switch
Right/Down
Less than 1 ohm
Neutral
More than 10K ohms

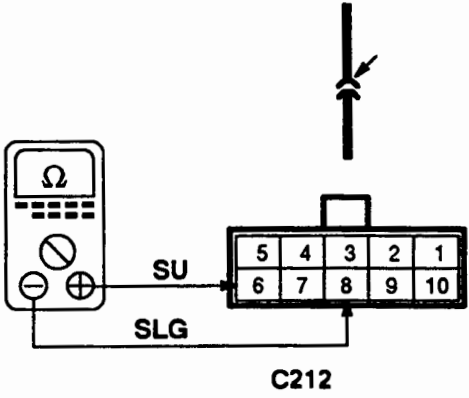



PROBLEM CAUSE

- SLG Wire
- Mirror Adjustment Switch



6A

6A

CONDITIONS

- Ignition Switch
Position: 0

RESULTS

- Mirror Adjustment Switch
Left/Up
Less than 1 ohm
Neutral
More than 10K ohms

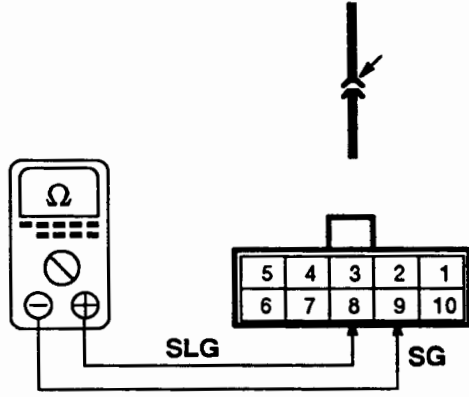



PROBLEM CAUSE

- Mirror Adjustment Switch

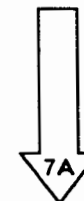

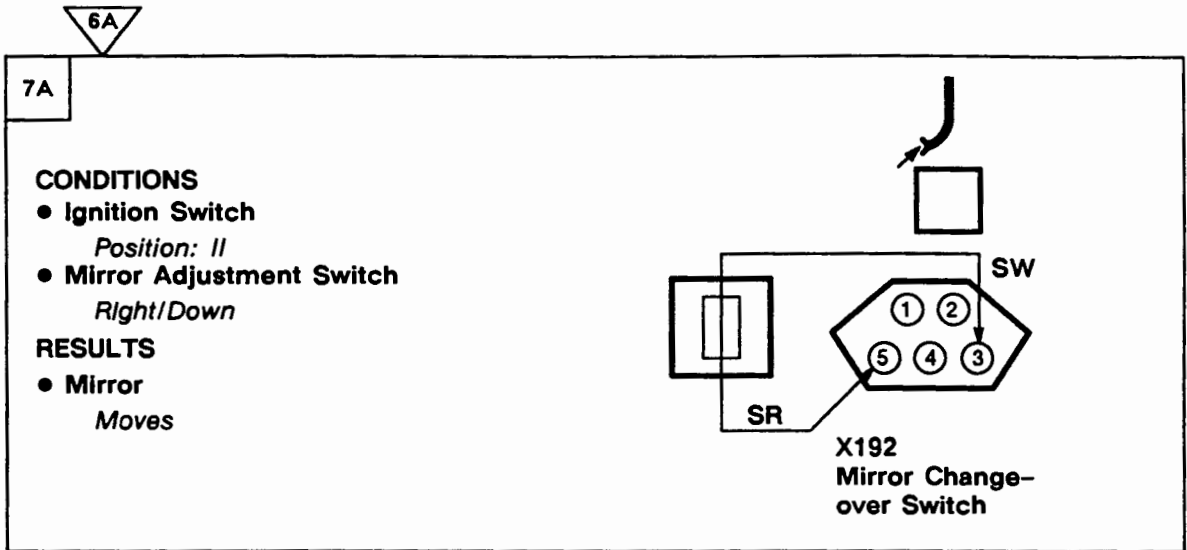

PROBLEM CAUSE

- SLG Wire
- SG Wire
- WP Wire
- Mirror Adjustment Switch
- M115, M123 Mirror Actuator



PROBLEM CAUSE

- Mirror Changeover Switch

Test B

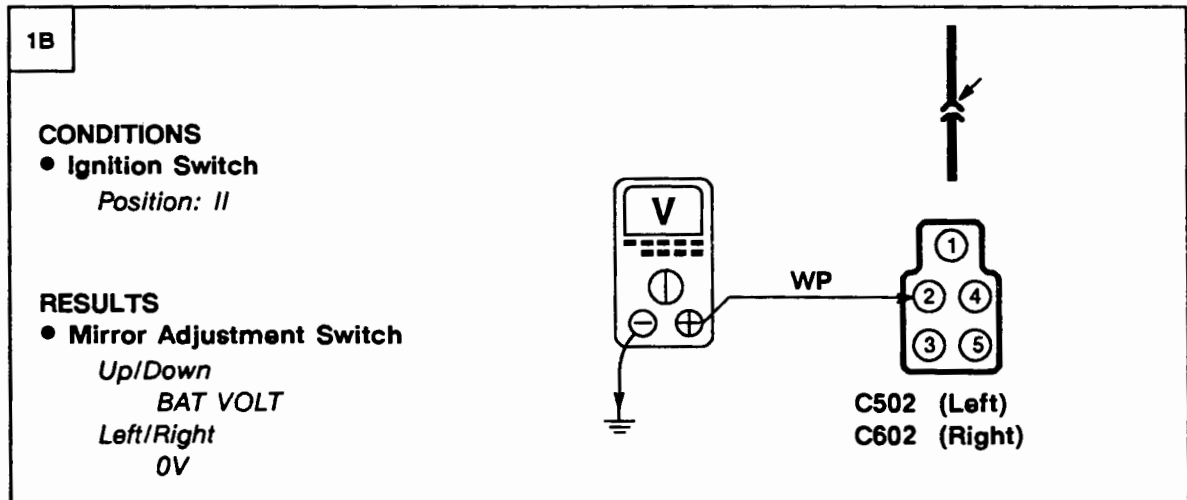

PROBLEM CAUSE

- WP Wire
- Mirror Adjustment Switch



M3 ETM

1992 RANGE ROVER

1B

2B

CONDITIONS

- Ignition Switch
Position: 0

RESULTS

Less than 1 ohm

C502 (Left)
C602 (Right)



PROBLEM CAUSE

- B Wire
- E200



PROBLEM CAUSE

- M115, M123 Mirror Actuator

Test C

1C

CONDITIONS

- Ignition Switch
Position: II
- Mirror Changeover Switch
Select Suspect Mirror

RESULTS

- Mirror Adjustment Switch
Right/Down
BAT VOLT
Left/Up
0V

PU 4 Door
PK 2 Door

C502 (Left)
C602 (Right)



PROBLEM CAUSE

- PU/PK Wire
- Mirror Changeover Switch

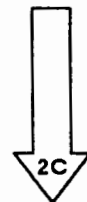

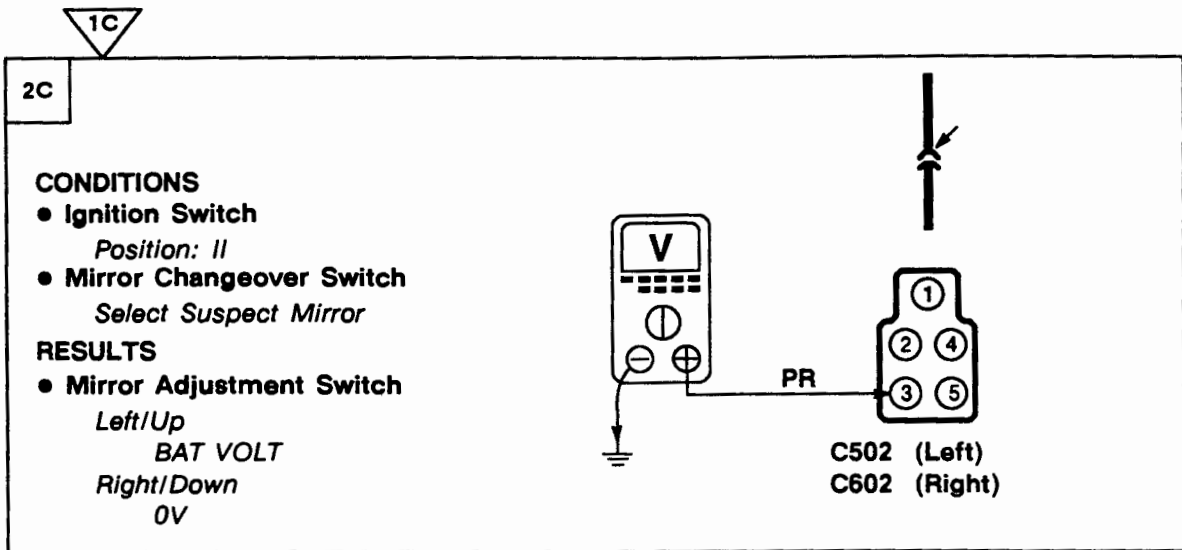

PROBLEM CAUSE

- PR Wire
- Mirror Changeover Switch



PROBLEM CAUSE

- M115, M123 Mirror Actuator

1992 RANGE ROVER

KEY INFORMATION

CIRCUIT DIAGRAMS

- Circuit diagrams are arranged so that current flow is from the top of the diagram (current source) to the bottom of the diagram (earth).
- Only those components that work together in the circuit are shown. If only part of a component is used in the circuit, then only that part of the component is shown.

Remember:

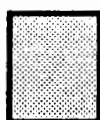

Entire component

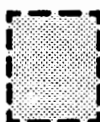

Part of a component

TERMINAL NUMBER

50

DESIGNATION

Battery voltage: Ignition Switch in position III

30

Battery voltage: supplied constantly

15

Battery voltage: Ignition Switch in position II or III

R

Battery voltage: Ignition Switch in positions I, II

31

Earth

See Introduction (i) for additional circuit diagram symbols.

DIAGNOSIS

- If the diagram is accompanied by text:
 - Read the Circuit Operation before proceeding with the electrical diagnosis.
 - Read the Troubleshooting Hints before performing the System Diagnosis.
 - Tests follow the System Diagnosis.
 - When performing the System Diagnosis, be certain that all components disconnected in previous steps are reconnected unless otherwise directed.



Component is disconnected.
Backprobe harness connector



Component is connected.
Backprobe harness connector

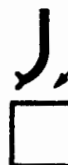

Component is disconnected.
Probe component



Component is disconnected.
Probe harness connector



Probe in-line connector

CIRCUIT OPERATION

Power and Earth

The Memory Seat Fuse (P115) applies battery voltage to retain the memory circuit of the Memory Seat ECU (Z146) at all times. Voltage to operate the seat motors (M126, M127, M128, M129) and the mirror actuators (M154, M123) is supplied to the Memory Seat ECU from fuses F E5 and F E6. The Fusible Link (P119) supplies voltage to fuses F E5 and F E6 whenever the Driver Seat Relay (K113) is energized. The relay is energized when the driver's door is open, causing the Driver Door Switch (X118) to earth the relay's coil, or when the ignition is in position 2, causing the Passenger Seat Relay (K131) to earth the Driver Seat Relay. The Memory Seat ECU is earthed at earth E301 through the B wires.

Inhibit Inputs

The Memory Seat ECU (Z146) will not permit movement to the memorized position when the ignition is position 2 unless the handbrake is applied and vehicle speed is below 6 kmh. Vehicles equipped with an automatic transmission must also be in PARK or NEUTRAL for operation to occur.

The ECU monitors the Handbrake Switch (X191) position at terminal C1/13. When the handbrake is in position 1, the brake is applied and earth is applied to the ECU terminal.

Vehicle speed is monitored by the ECU at terminal C1/20 through the speed output signal supplied by the Vehicle Speed Sensor Buffer (Z160).

The ECU monitors gear position through the Starter Inhibit/Reverse Switch (X167). The switch earths the ECU at terminal C1/24 when the transmission is in PARK or NEUTRAL.

Seat Motors

4 reversible motors control seat position, with each motor controlling 1 plane of movement. The Memory Seat ECU (Z146) applies both voltage and earth to the motors based on the position of the Driver Seat Control Switch (X121) or the execution of a memory position.

Memory Mirror Actuators (M115, M123)

Each Memory Mirror Actuator contains 2 motors which controls 1 plain of movement. The Memory Seat ECU (Z146) applies both voltage and earth to the motors based on the position of the Mirror Adjustment Switch (X146) or the execution of a memory position.

Setting Memory

When the round, green memory set button is depressed, terminal C3/10 of the Memory Seat ECU (Z146) is earthed through the switch contacts. This signals the ECU to record the seat position as reported through the seat position sensors (X194, X195, X196, X197) and the mirror positions through the potentiometers of the Memory Mirror Actuators (M115, M123).

When memory seat position switch 1 or 2 is depressed, ECU terminals C3/8 or C3/9 are earthed through the switch. This signals ECU to record the current position as position '1' or '2'. Subsequent depressions of memory seat position switch 1 or 2 will cause the ECU to move the seat and mirrors to the position retained in memory. The memory can be cleared by setting a new position or by removing the Memory Seat Fuse (P115).

SELF TEST MODE

The Self Test Mode is a test routine the Memory Seat ECU (Z146) performs when initialized. When the ECU is commanded into the Self Test Mode, it operates the seats and the mirrors in all planes of travel. Perform the self test before attempting any diagnosis of the memory seat and mirror system. The cause of a system fault can be narrowed down through observation of the seats and mirrors during the Self Test Mode.

To initialize the Self Test Mode, do the following:

1. Park vehicle and open driver's door.
2. Press round, green memory button 5 times.
3. Press seat position buttons 1 and 2 in the following sequence:
2-1-1-2

Seat and mirrors will now move. The test is completed when the seat and mirrors stop in the mid-travel position.

If a motor did not operate at all during the test sequence, that motor or its wiring is faulty. If a motor moves in a plane and then suddenly stops, a loss of the feedback position is indicated. Proceed to the System Diagnosis for further testing.

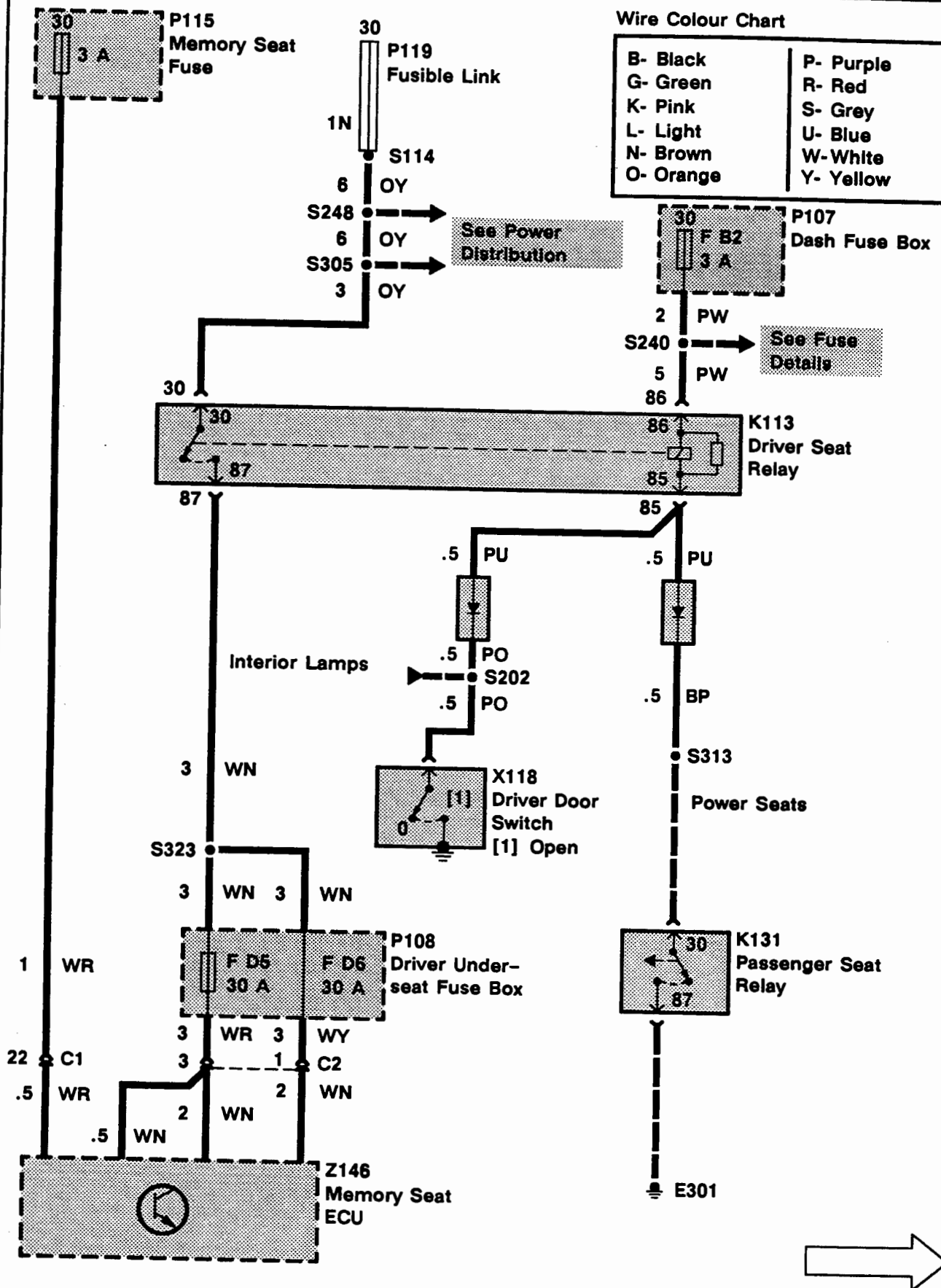

M5 ETM

1992 RANGE ROVER

Wire Colour Chart

B- Black	P- Purple
G- Green	R- Red
K- Pink	S- Grey
L- Light	U- Blue
N- Brown	W- White
O- Orange	Y- Yellow

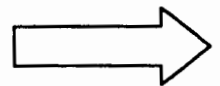
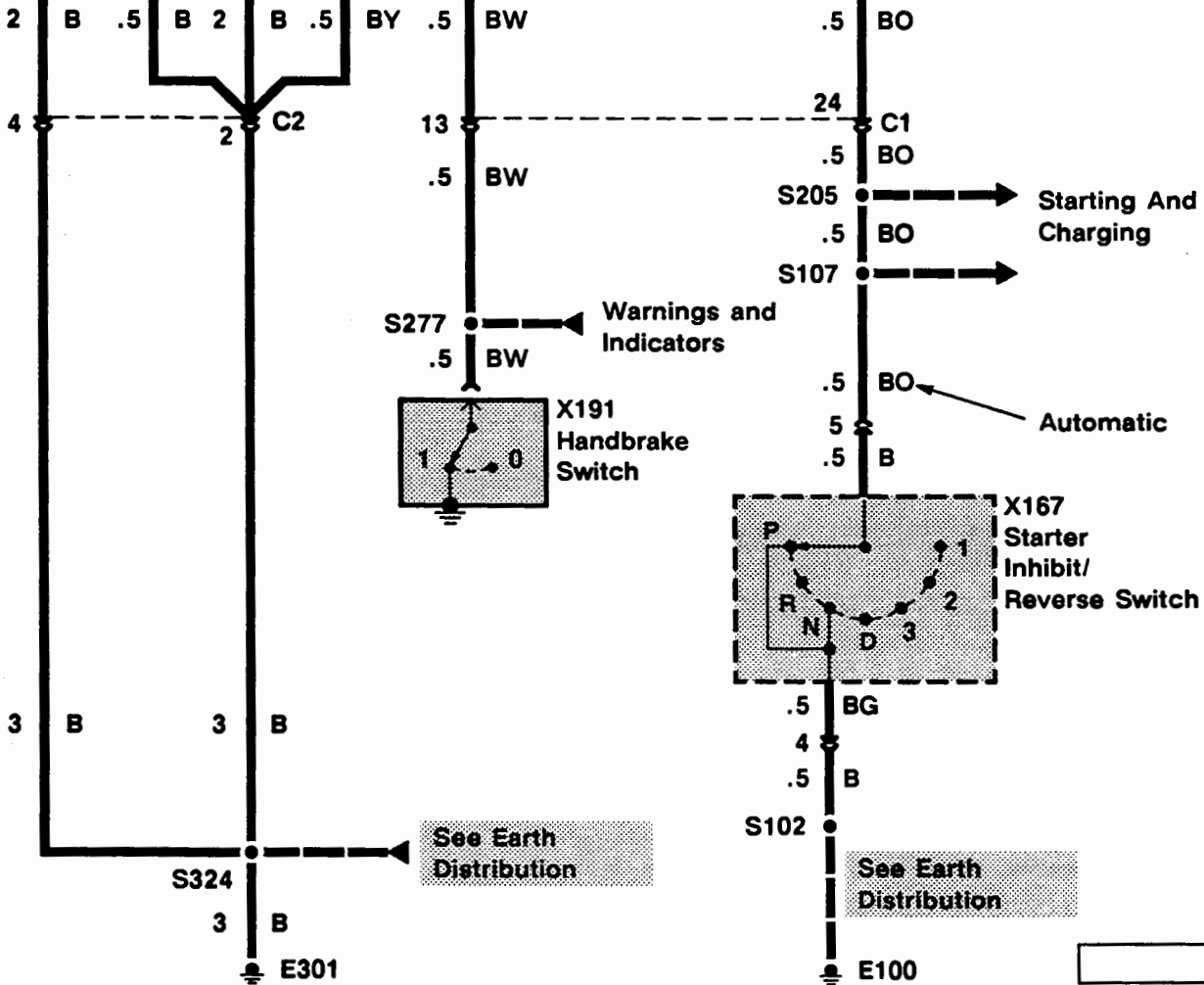
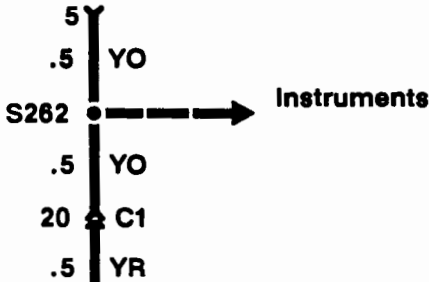
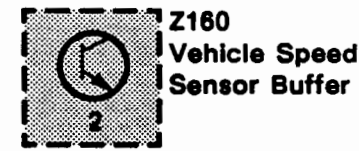
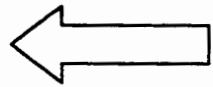

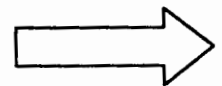
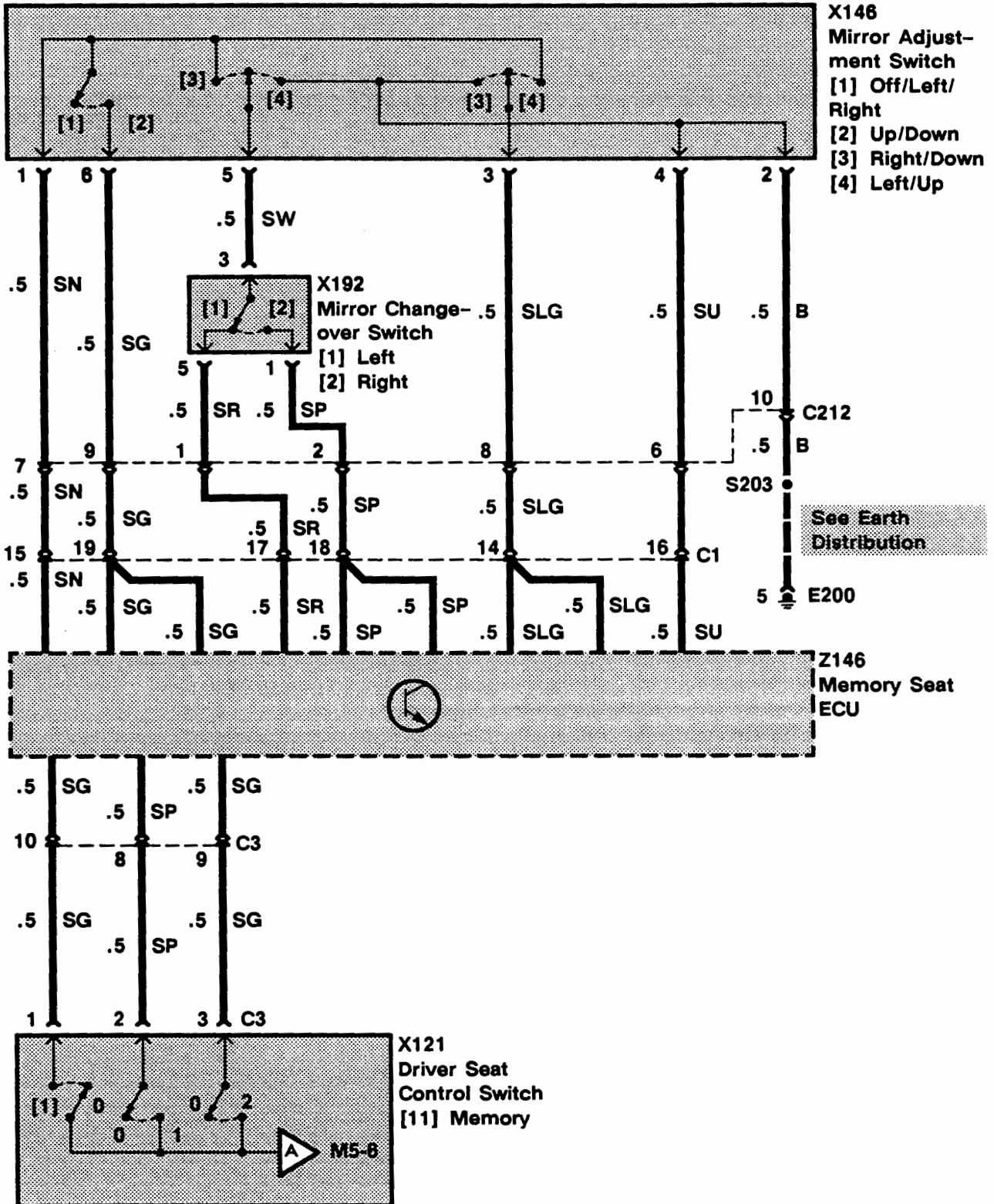
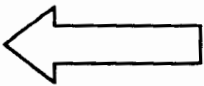

M5 ETM

1992 RANGE ROVER

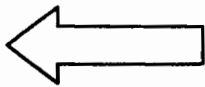

* LHD
** RHD

Wire Colour Chart

B- Black	P- Purple
G- Green	R- Red
K- Pink	S- Grey
L- Light	U- Blue
N- Brown	W- White
O- Orange	Y- Yellow

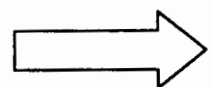
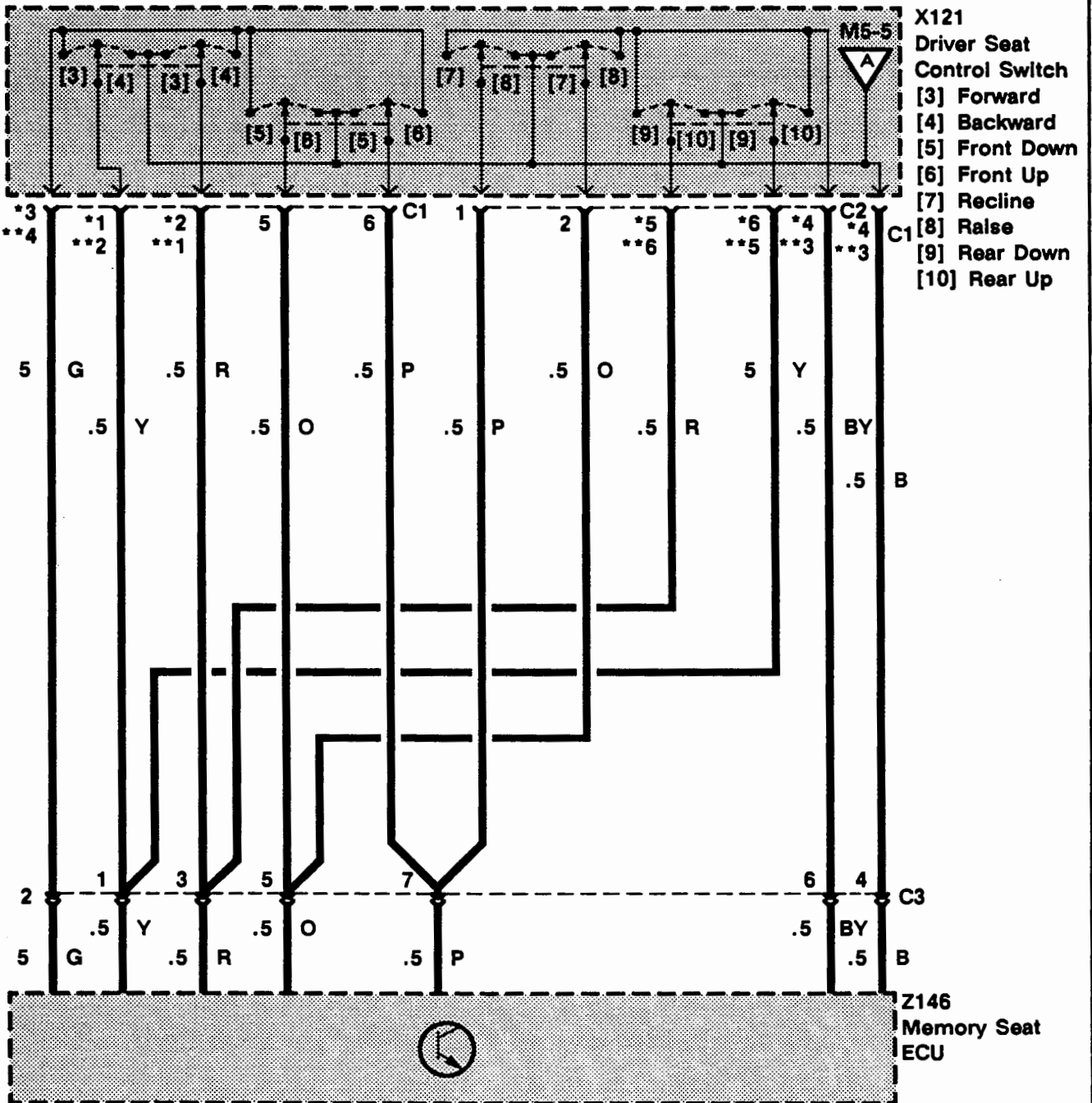

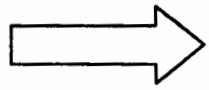
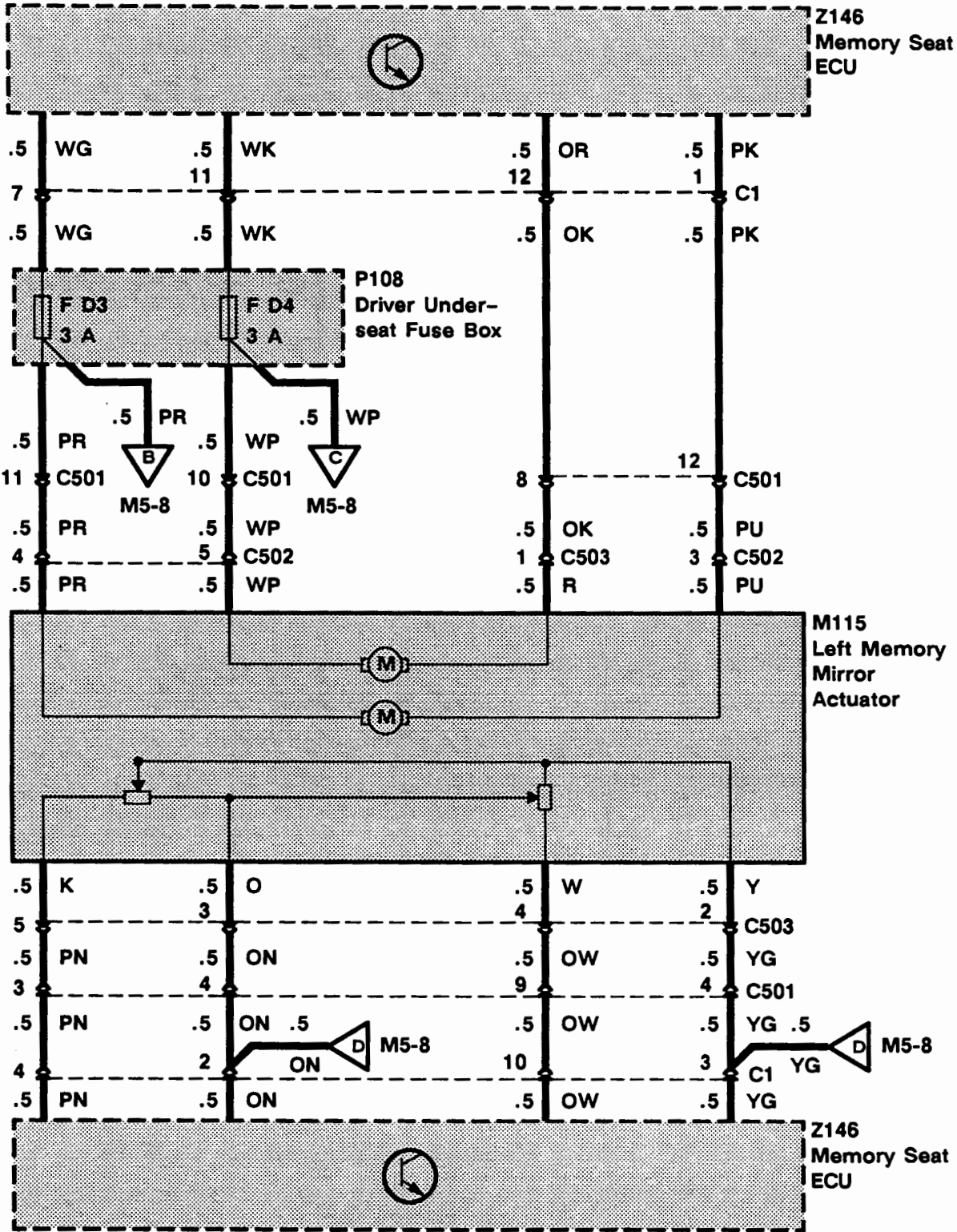
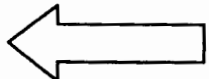

M5 ETM

1992 RANGE ROVER

Wire Colour Chart

B- Black	P- Purple
G- Green	R- Red
K- Pink	S- Grey
L- Light	U- Blue
N- Brown	W- White
O- Orange	Y- Yellow

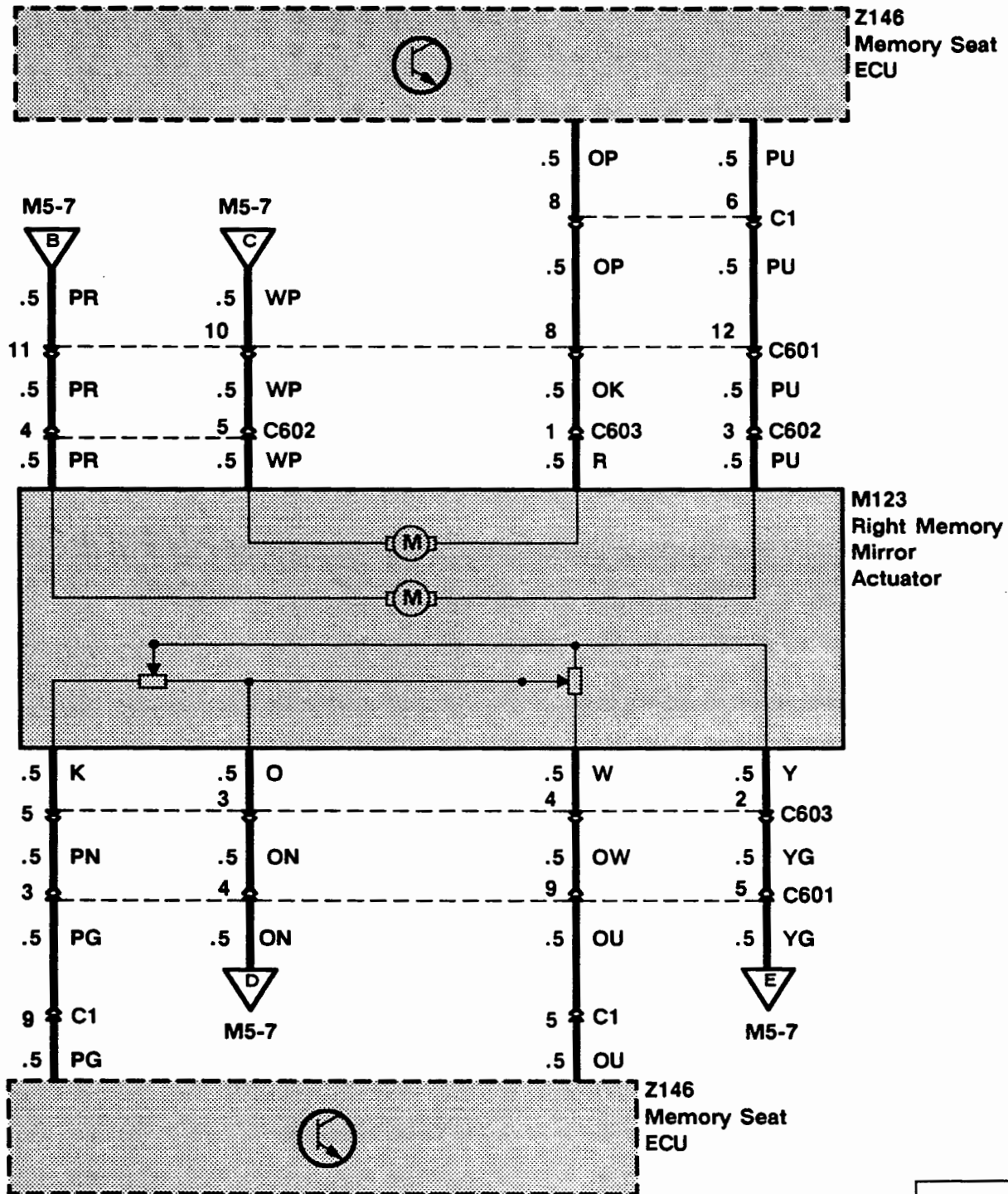

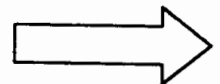
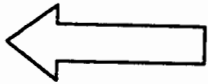
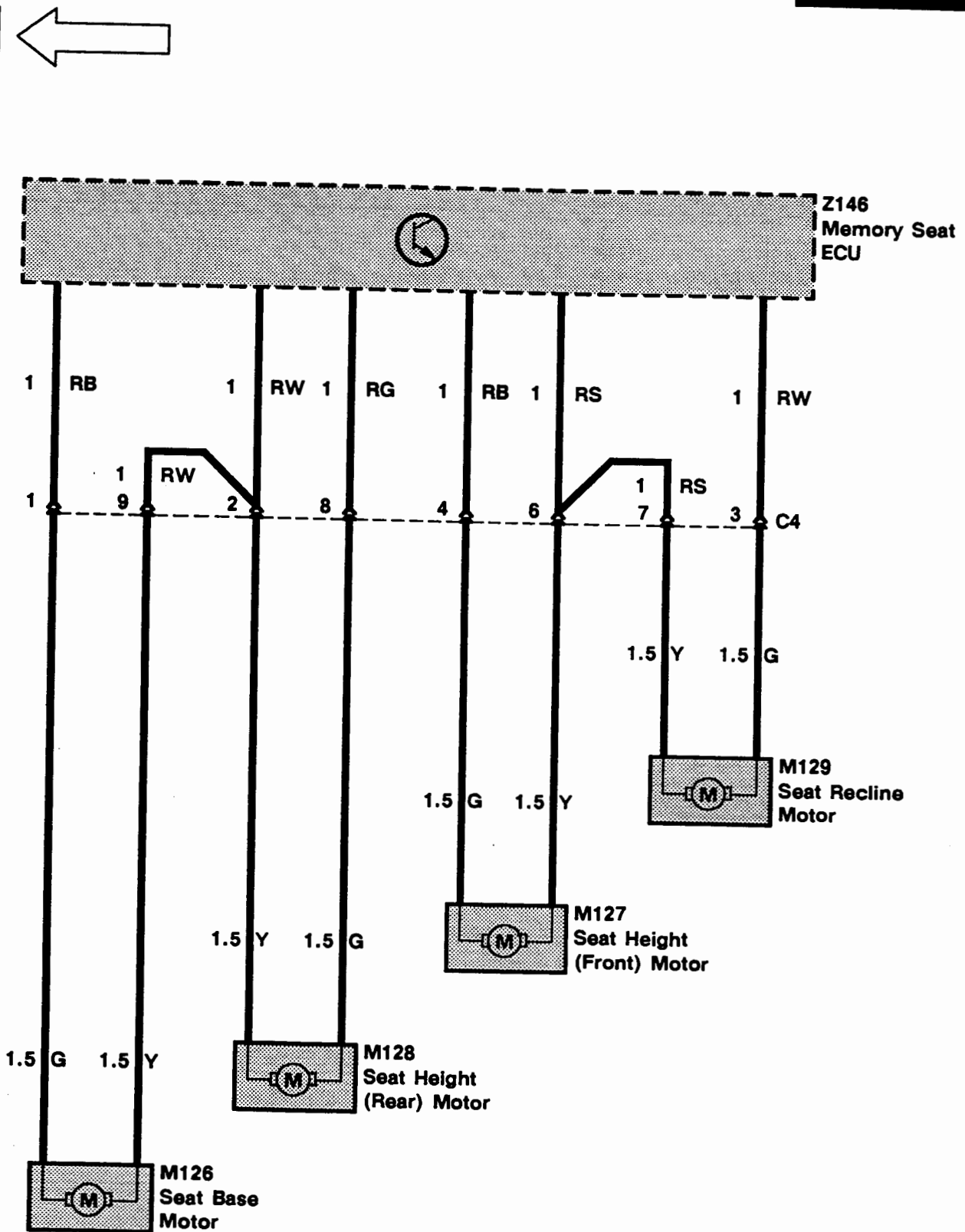

M5 ETM

1992 RANGE ROVER

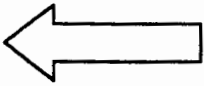

Wire Colour Chart

B- Black	P- Purple
G- Green	R- Red
K- Pink	S- Grey
L- Light	U- Blue
N- Brown	W- White
O- Orange	Y- Yellow

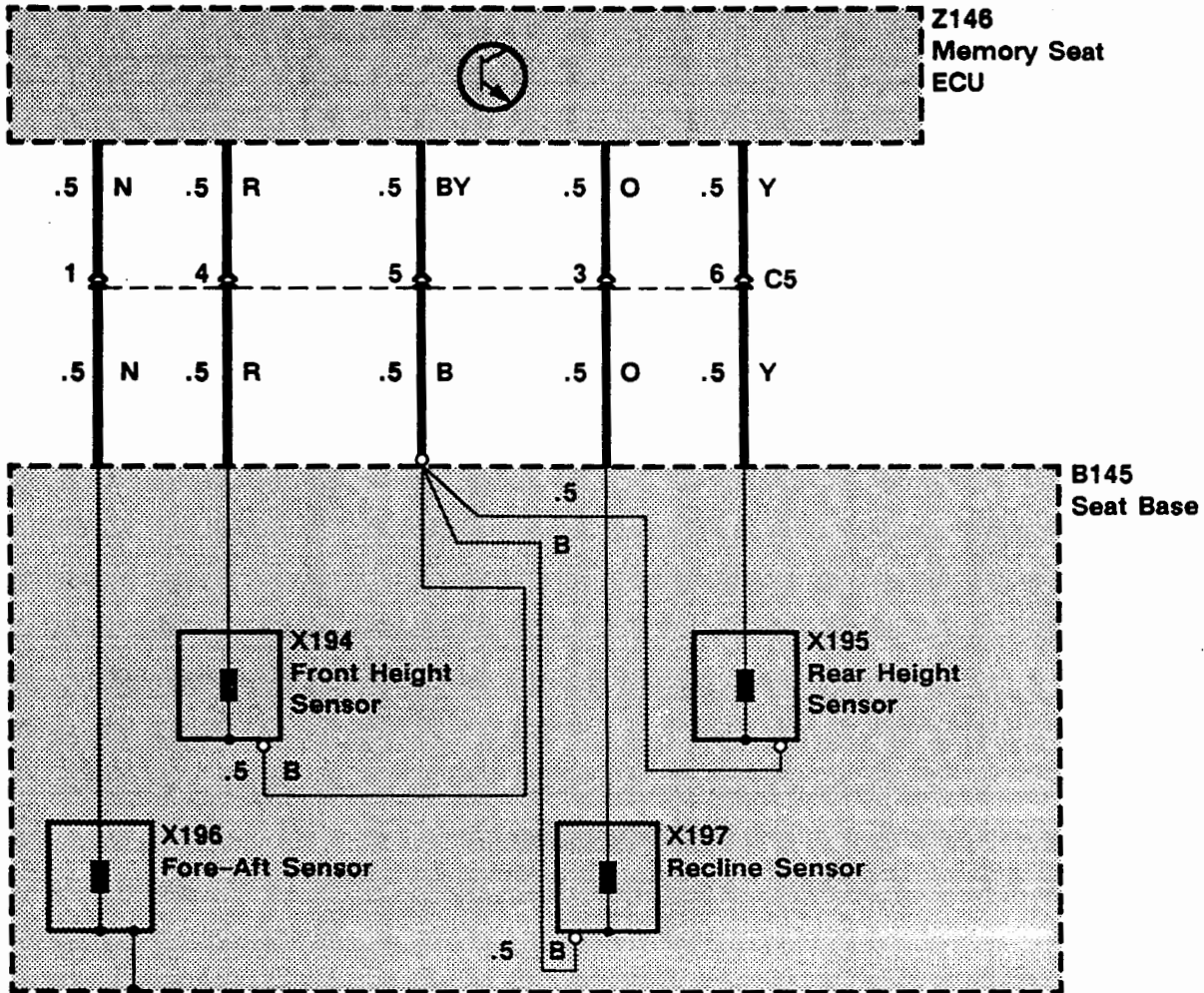

SYSTEM DIAGNOSIS

NOTE: Perform the Self Test before performing any diagnosis on the memory seats and mirrors.

1. If the system will not perform the Self Test, do Test E, Driver Seat Control Switch (X121) test.
2. If manual and memory seat functions are totally inoperative, check the Memory Seat Fuse (P115) and fuses F E5 and F E6. Do Test A if the fuses are OK.
3. If the system does not retain memory seat or mirror positions, do Test A, Memory Seat ECU (Z146) power test.
4. If the memory seat system does not operate when the ignition is in position II and the handbrake is applied, do Test B (manual transmission) or Test C (automatic transmission).
5. If memory seat and mirror functions do not operate but the seat does operate in some modes manually, do Test E, Driver Seat Control Switch (X121) test.
6. If all seat motors operate during the Self Test but do not operate when the Driver Seat Control Switch (X121) is used, do Test F.
7. If all mirror motors operate during the Self Test but do not operate when the Mirror Adjustment Switch (X146) is used, do Test G.
8. If a seat motor moves during the Self Test and then stops, replace the defective seat sensor (X194, X195, X196, X197).
9. If a seat motor (M126, M127, M128, M129) does not move at all during the Self Test, do Test J.
10. If a mirror motor does not move at all during the Self Test, do Test K (Left Memory Mirror Actuator, M115) or Test L (Right Memory Mirror Actuator, M123).
11. If a mirror motor moves during the Self Test and then stops, do Test H (Left Memory Mirror Actuator, M115) or Test I (Right Memory Mirror Actuator, M123).

THIS PAGE HAS BEEN INTENTIONALLY LEFT BLANK

Test A

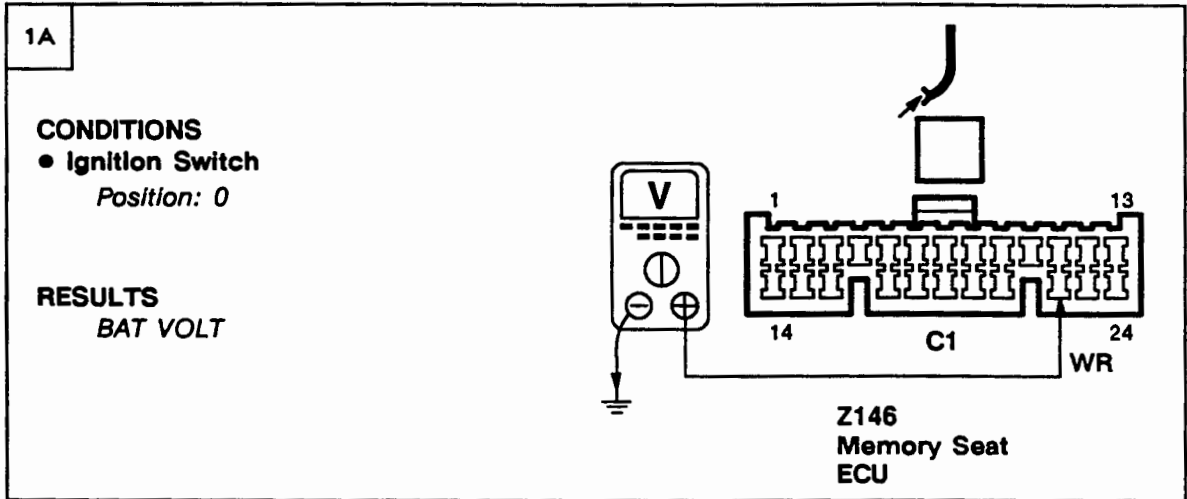

PROBLEM CAUSE

- WR Wire
- Memory Seat Fuse

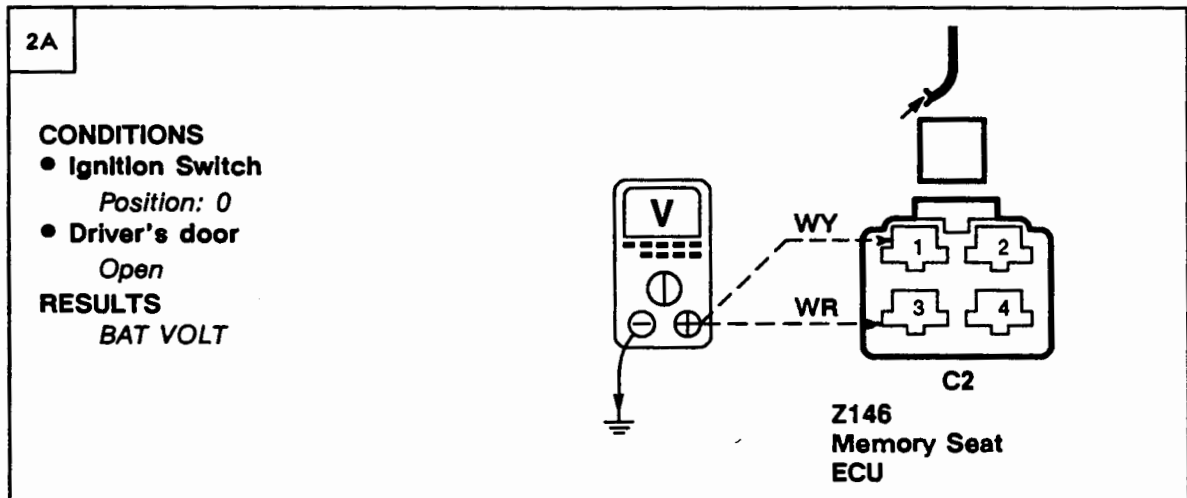

GO TO TEST D



M5 ETM

1992 RANGE ROVER

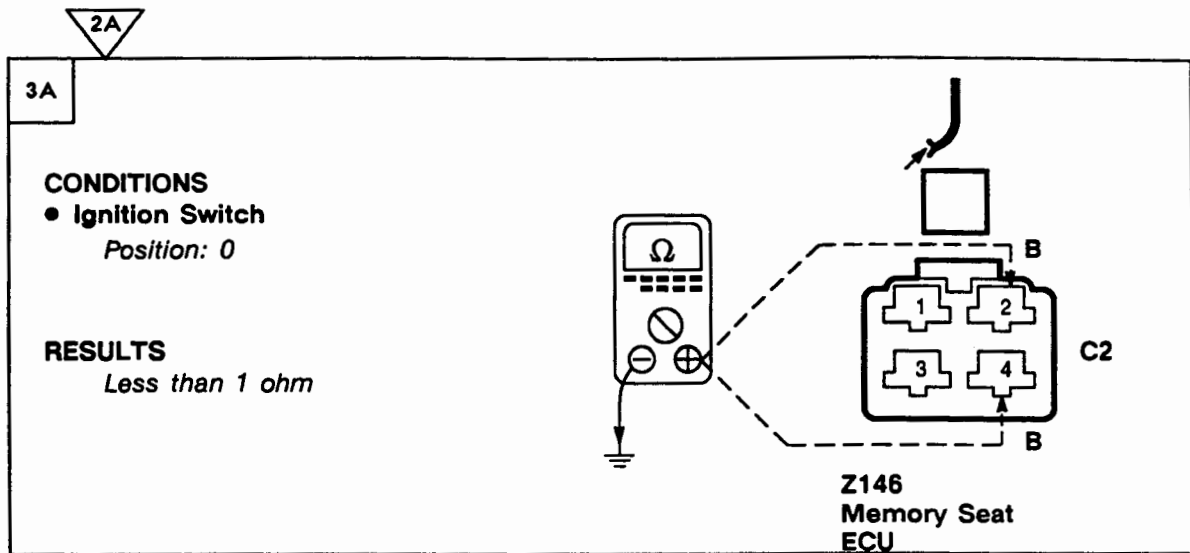

PROBLEM CAUSE
- B Wire



PROBLEM CAUSE
- Memory Seat ECU

Test B

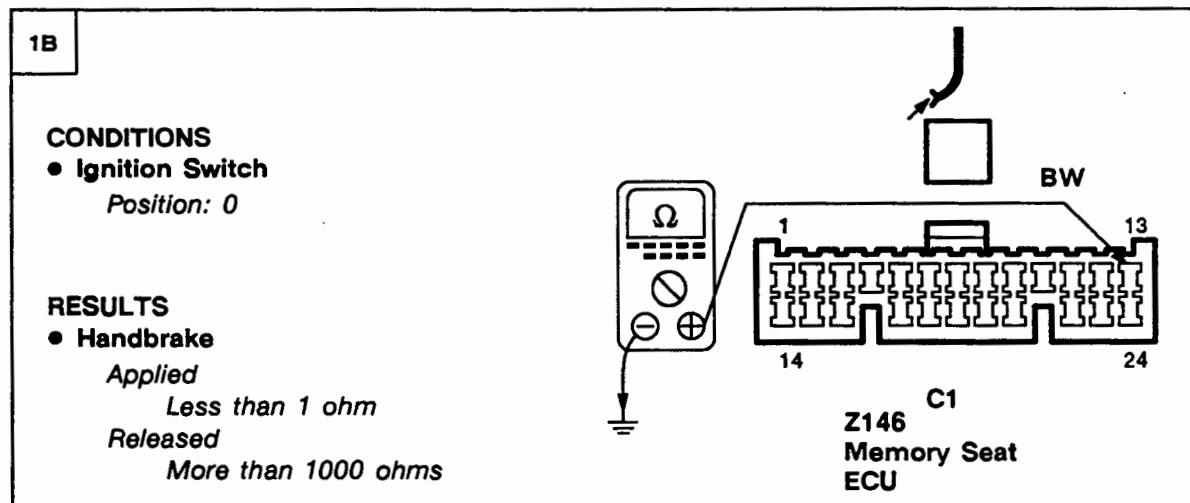

PROBLEM CAUSE
- BW Wire
- Handbrake Switch



PROBLEM CAUSE
- Memory Seat ECU

Test C

1C

CONDITIONS

- Ignition Switch
Position: 0

RESULTS

- Handbrake
Applied
Less than 1 ohm
- Released*
More than 1000 ohms

**Z146
Memory Seat
ECU**



PROBLEM CAUSE

- BW Wire
- Handbrake Switch



2C

CONDITIONS

- Ignition Switch
Position: 0
- Gear Selector
Park

RESULTS

- Less than 1 ohm*

**Z146
Memory Seat
ECU**



PROBLEM CAUSE

- BO Wire



PROBLEM CAUSE

- Memory Seat ECU

Test D

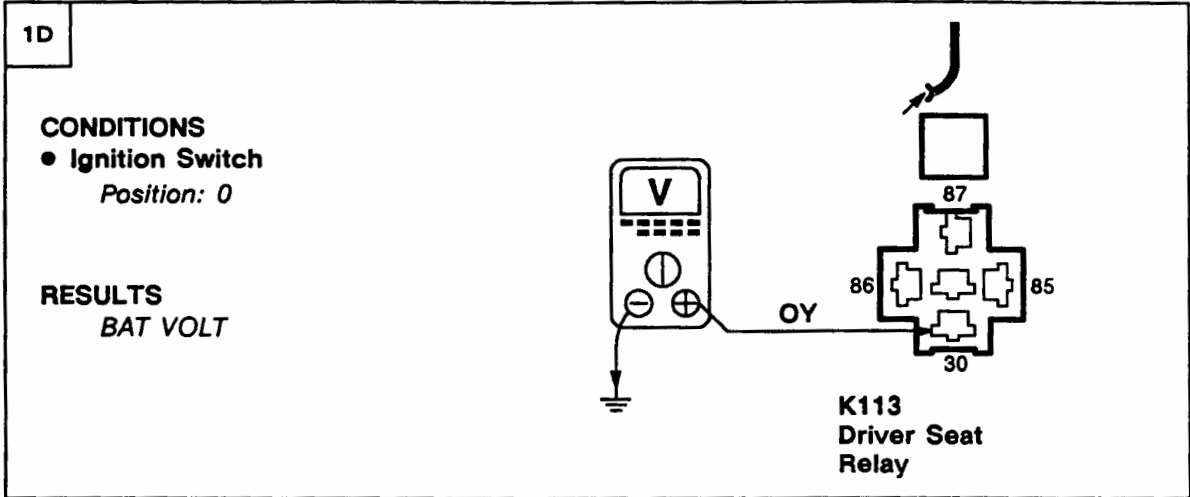

OK PROBLEM CAUSE
 - OY Wire
 - Fusible Link

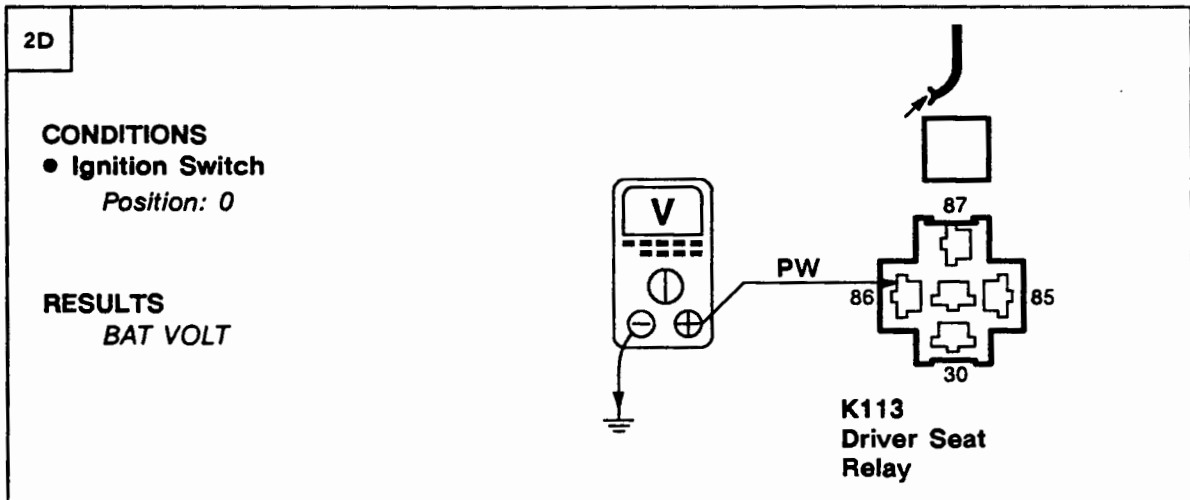
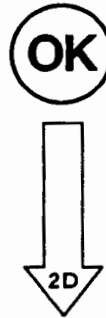

OK PROBLEM CAUSE
 - F B2 Fuse
 - PW Wire

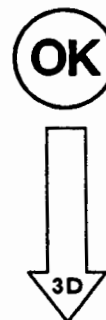

2D

3D

CONDITIONS

- Ignition Switch
Position: 0
- Driver's door
Open

RESULTS
Less than 1 ohm

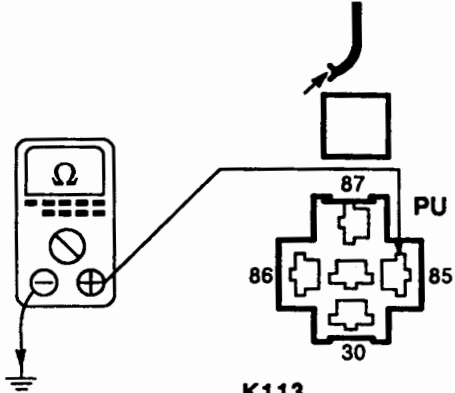

**K113
Driver Seat
Relay**



PROBLEM CAUSE

- PU Wire
- Driver Door Switch

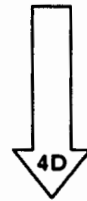

4D

4D

CONDITIONS

- Ignition Switch
Position: II
- Driver's door
Closed

RESULTS
Less than 1 ohm

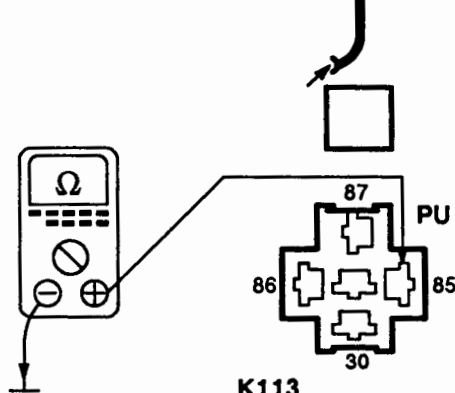

**K113
Driver Seat
Relay**



PROBLEM CAUSE

- PU Wire
- BP Wire



4D

5D

CONDITIONS

- Ignition Switch
Position: 0

RESULTS

- Seat memory
Operates

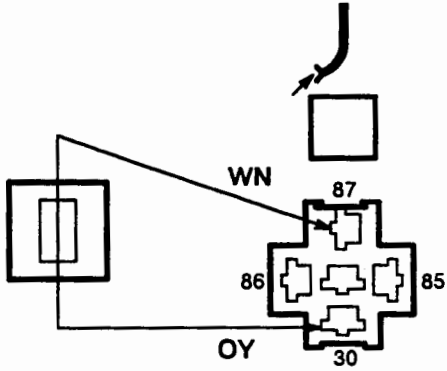

**K113
Driver Seat
Relay**



PROBLEM CAUSE

- F E5 Fuse
- F E6 Fuse
- WN Wire



PROBLEM CAUSE

- Driver Seat Relay

Test E

1E

CONDITIONS

- Ignition Switch
Position: 0

RESULTS

- Green memory button
*Depressed
Less than 1 ohm
Released
More than 10K ohms*

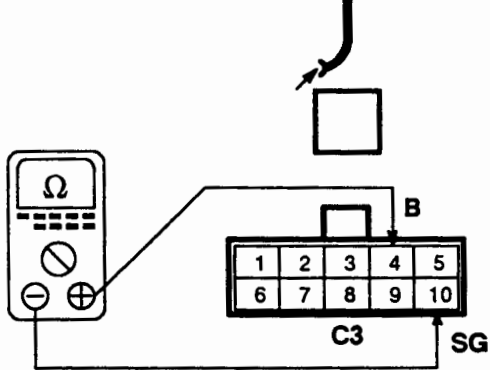

**Z146
Memory Seat
ECU**



PROBLEM CAUSE

- SG Wire
- B Wire
- Driver Seat Control Switch



1E

2E

CONDITIONS

- Ignition Switch
Position: II

RESULTS

- Position 1 button
Depressed
Less than 1 ohm
Released
More than 10K ohms

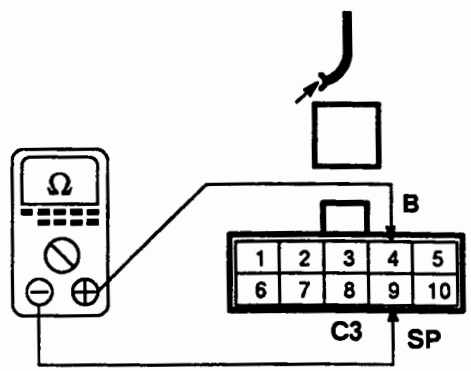

Z146
Memory Seat
ECU

OK PROBLEM CAUSE

- SP Wire
- Driver Seat Control Switch

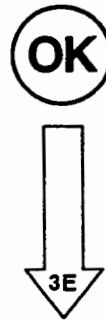

3E

CONDITIONS

- Ignition Switch
Position: 0

RESULTS

- Position 2 button
Depressed
Less than 1 ohm
Released
More than 10K ohms

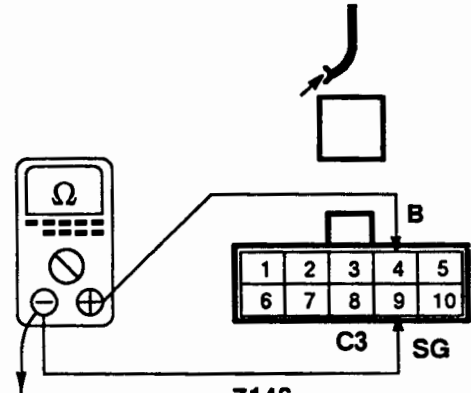

Z146
Memory Seat
ECU

OK PROBLEM CAUSE

- SG Wire
- Driver Seat Control Switch

OK PROBLEM CAUSE

- Memory Seat ECU

Test F

1F

CONDITIONS

- Ignition Switch
Position: 0
- Driver Seat Control Switch
Forward

RESULTS
Less than 1 ohm

**Z146
Memory Seat
ECU**



PROBLEM CAUSE

- G Wire
- Y Wire
- Driver Seat Control Switch



2F

CONDITIONS

- Ignition Switch
Position: 0

RESULTS
More than 10K ohms

**Z146
Memory Seat
ECU**



PROBLEM CAUSE

- Wire
- Driver Seat Control Switch



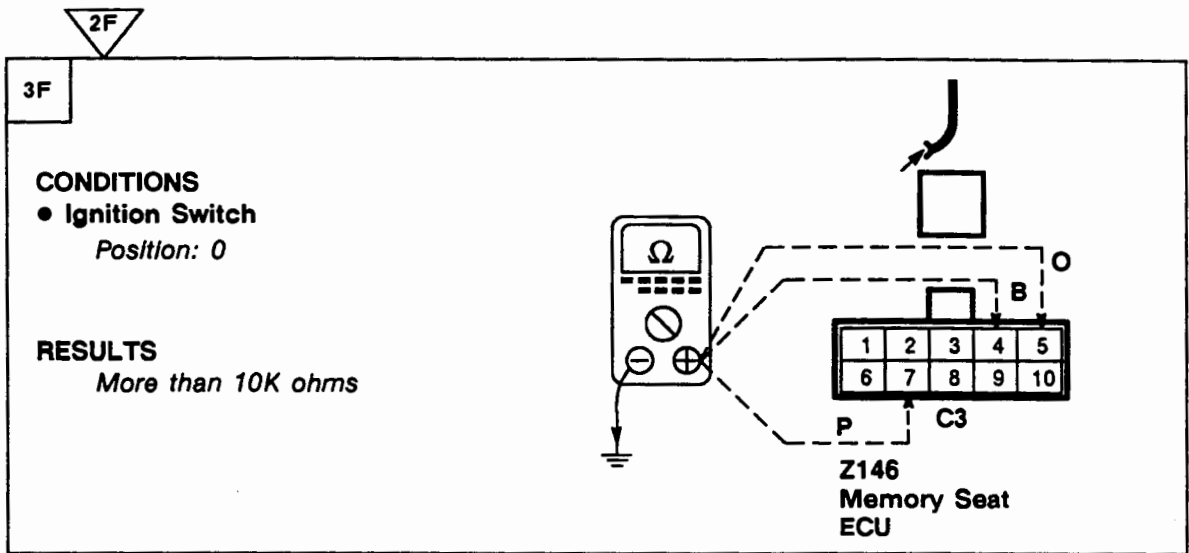

PROBLEM CAUSE

- Wire
- Driver Seat Control Switch

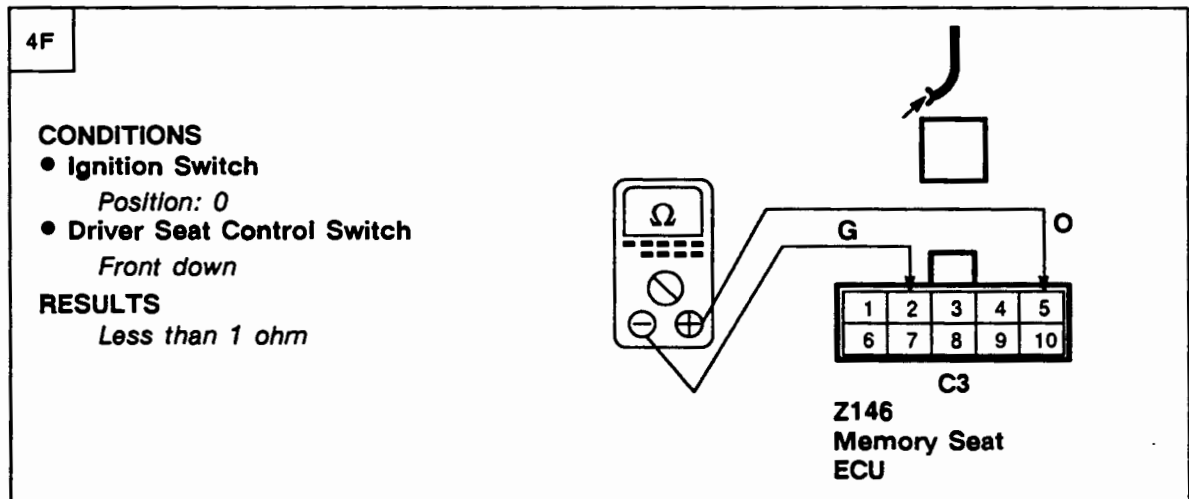
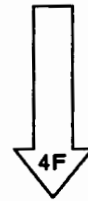

PROBLEM CAUSE

- O Wire
- Driver Seat Control Switch

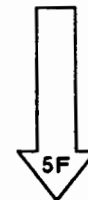

M5 ETM

1992 RANGE ROVER

4F

5F

CONDITIONS

- Ignition Switch
Position: 0
- Driver Seat Control Switch
Recline

RESULTS
Less than 1 ohm

Z146
Memory Seat
ECU

- OK
- PROBLEM CAUSE**
- P Wire
 - BY Wire
 - Driver Seat Control Switch

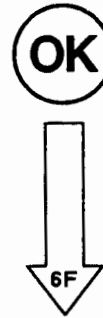

6F

CONDITIONS

- Ignition Switch
Position: 0
- Driver Seat Control Switch
Raise

RESULTS
Less than 1 ohm

Z146
Memory Seat
ECU

- OK
- PROBLEM CAUSE**
- P Wire
 - Driver Seat Control Switch

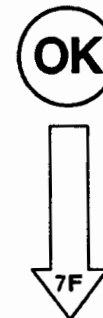

6F

7F

CONDITIONS

- Ignition Switch
Position: 0
- Driver Seat Control Switch
Rear up

RESULTS
Less than 1 ohm

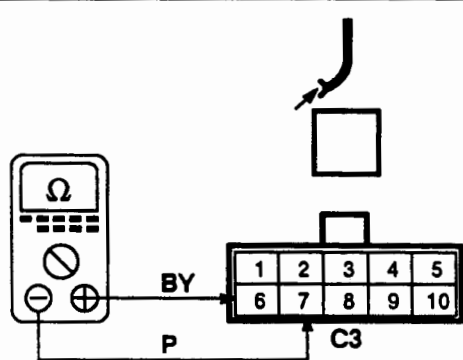

Z146
Memory Seat
ECU

~~OK~~ PROBLEM CAUSE

- BY Wire
- Driver Seat Control Switch

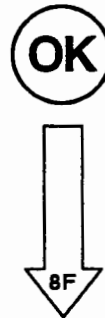

8F

8F

CONDITIONS

- Ignition Switch
Position: 0
- Driver Seat Control Switch
Rear down

RESULTS
Less than 1 ohm

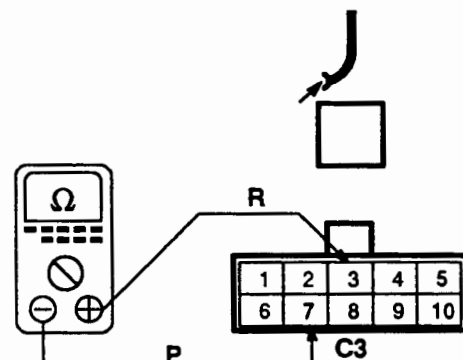

Z146
Memory Seat
ECU

~~OK~~ PROBLEM CAUSE

- R Wire
- Driver Seat Control Switch

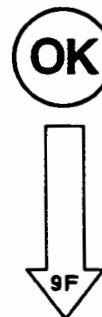

8F

9F

CONDITIONS

- Ignition Switch
Position: 0
- Driver Seat Control Switch
Front up

RESULTS
Less than 1 ohm

Z154
Rear Wipe
Delay Unit



PROBLEM CAUSE

- P Wire
- Driver Seat Control Switch



10F

CONDITIONS

- Ignition Switch
Position: 0
- Driver Seat Control Switch
Backward

RESULTS
Less than 1 ohm

Z146
Memory Seat
ECU



PROBLEM CAUSE

- R Wire
- Driver Seat Control Switch



PROBLEM CAUSE

- Memory Seat ECU

Test G

1G

CONDITIONS

- Ignition Switch
Position: 0
- Mirror Adjustment Switch
Up

RESULTS
Less than 1 ohm

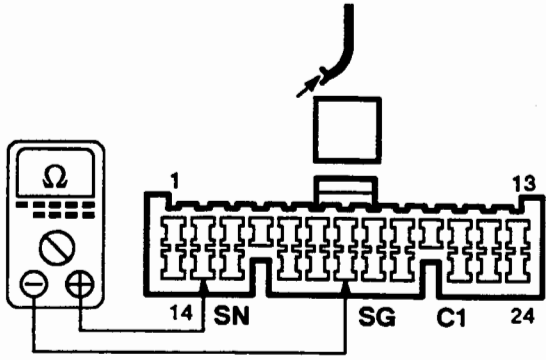

Z146
Memory Seat
ECU



PROBLEM CAUSE

- SN Wire
- SG Wire
- Mirror Adjustment Switch



2G

CONDITIONS

- Ignition Switch
Position: 0
- Mirror Adjustment Switch
Down
- Mirror Changeover Switch
Left

RESULTS
Less than 1 ohm

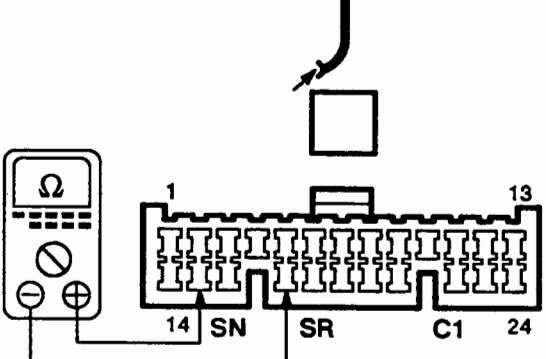

Z146
Memory Seat
ECU



PROBLEM CAUSE

- SR Wire
- SW Wire
- Mirror Changeover Switch
- Mirror Adjustment Switch



M5 ETM

1992 RANGE ROVER

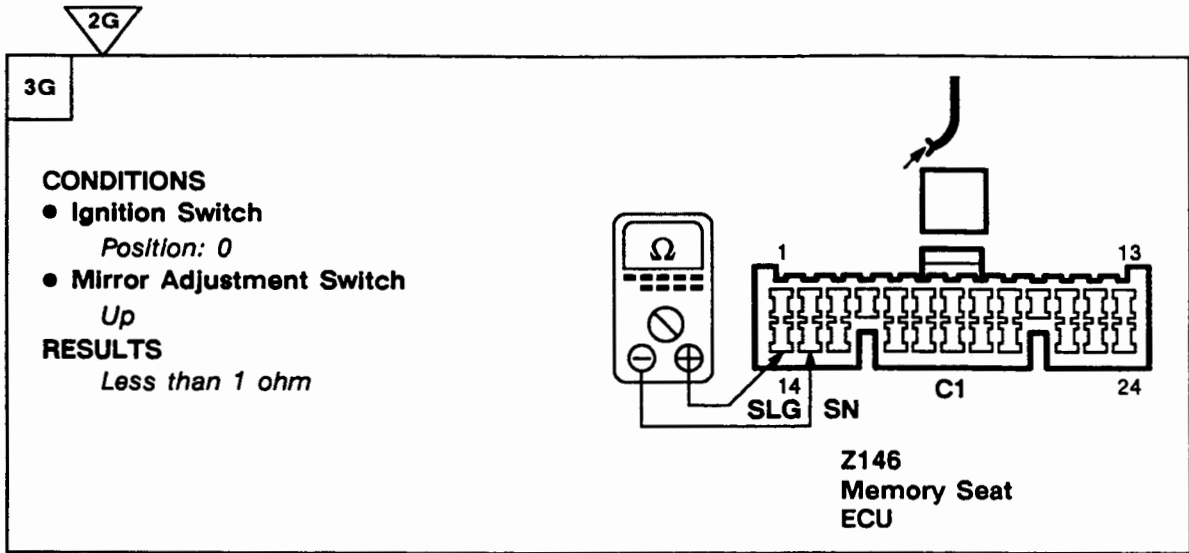

PROBLEM CAUSE

- SLG Wire
- Mirror Adjustment Switch

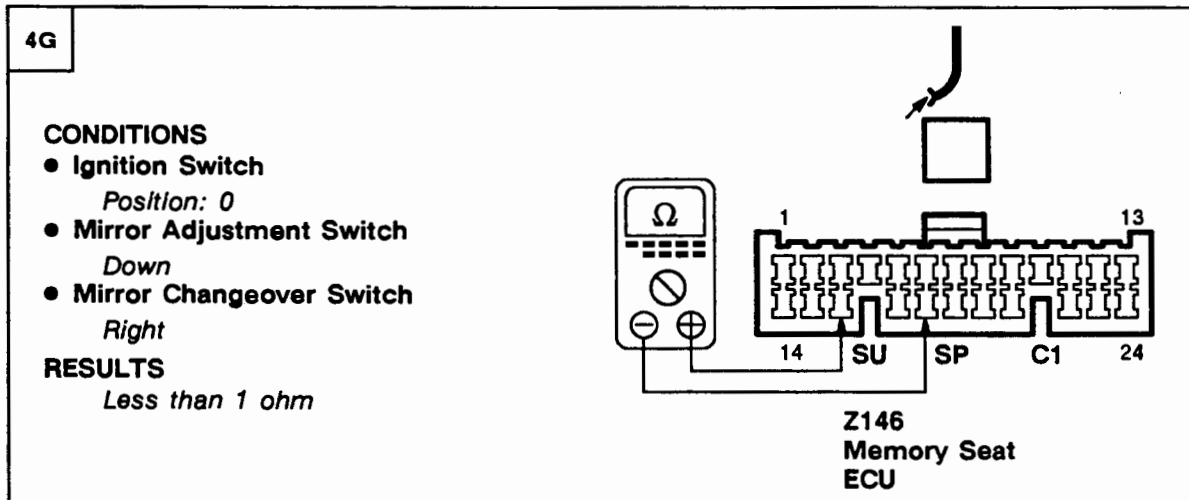

PROBLEM CAUSE

- SP Wire
- SU Wire
- Mirror Changeover Switch



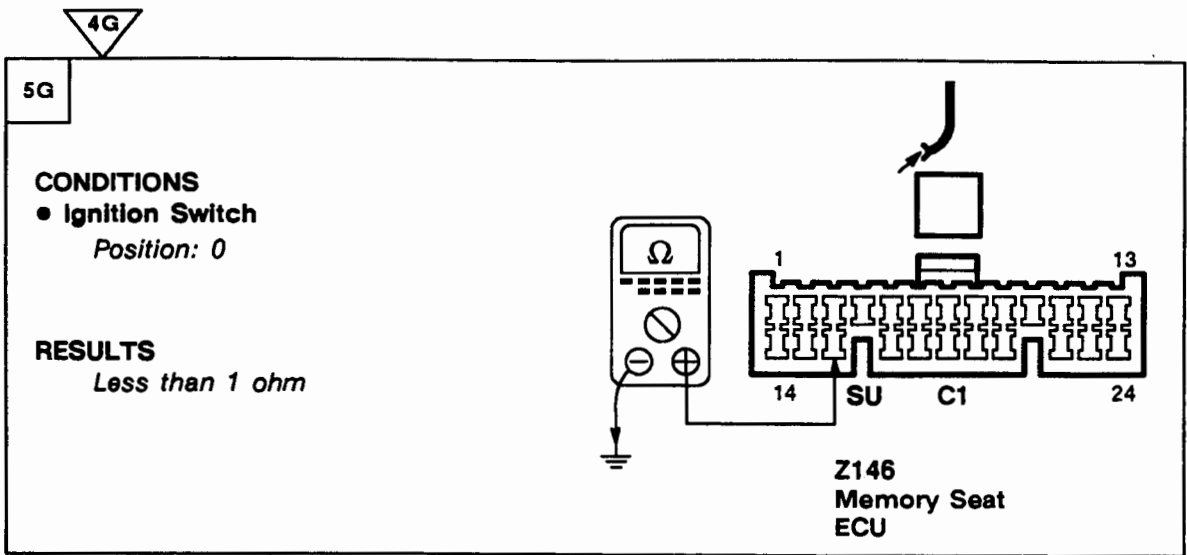

PROBLEM CAUSE
 - B Wire
 - Mirror Adjustment Switch



PROBLEM CAUSE
 - Memory Seat ECU

Test H

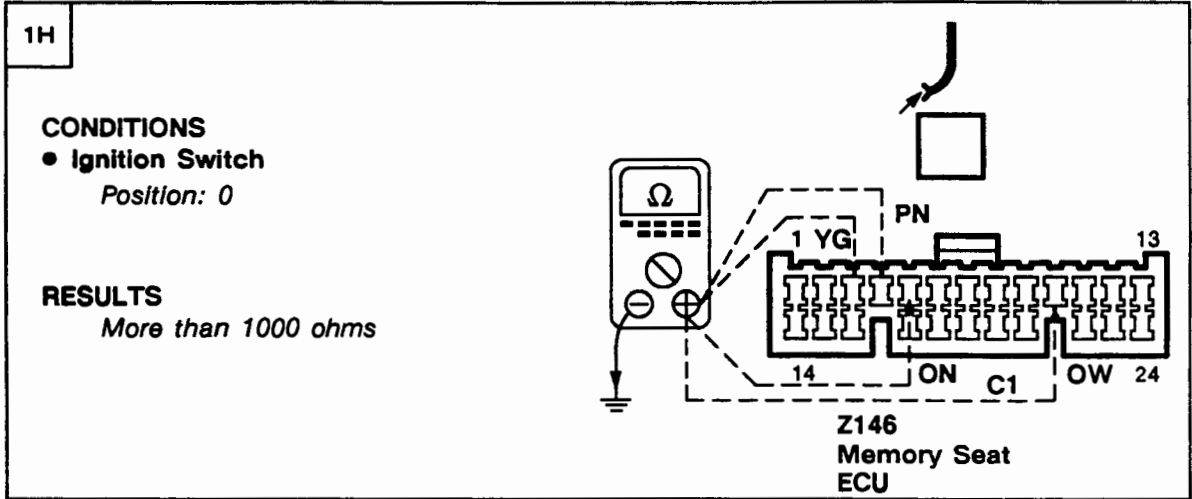

PROBLEM CAUSE

- YG Wire
- PN Wire
- ON Wire
- OW Wire
- Left Memory Mirror Actuator

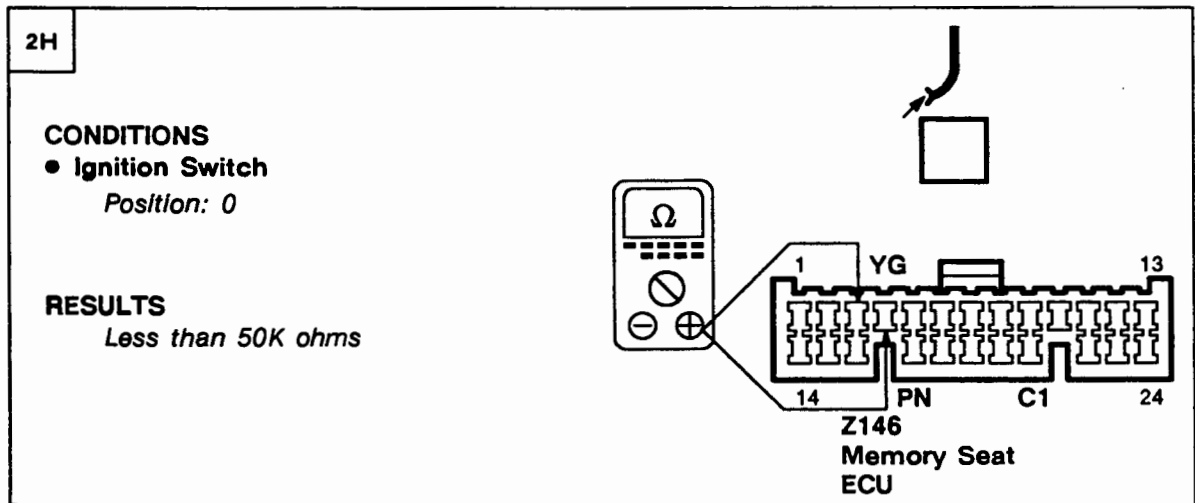
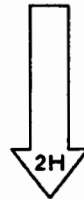

PROBLEM CAUSE

- PN Wire
- YG Wire
- Left Memory Mirror Actuator



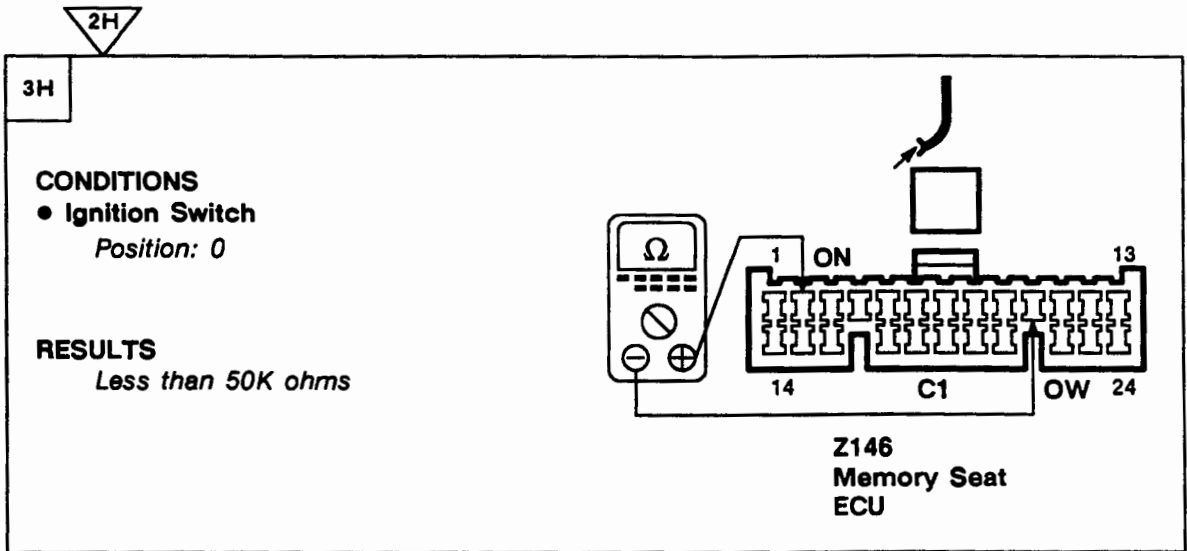

PROBLEM CAUSE

- ON Wire
- OW Wire
- Left Memory Mirror Actuator



PROBLEM CAUSE

- Memory Seat ECU

Test I

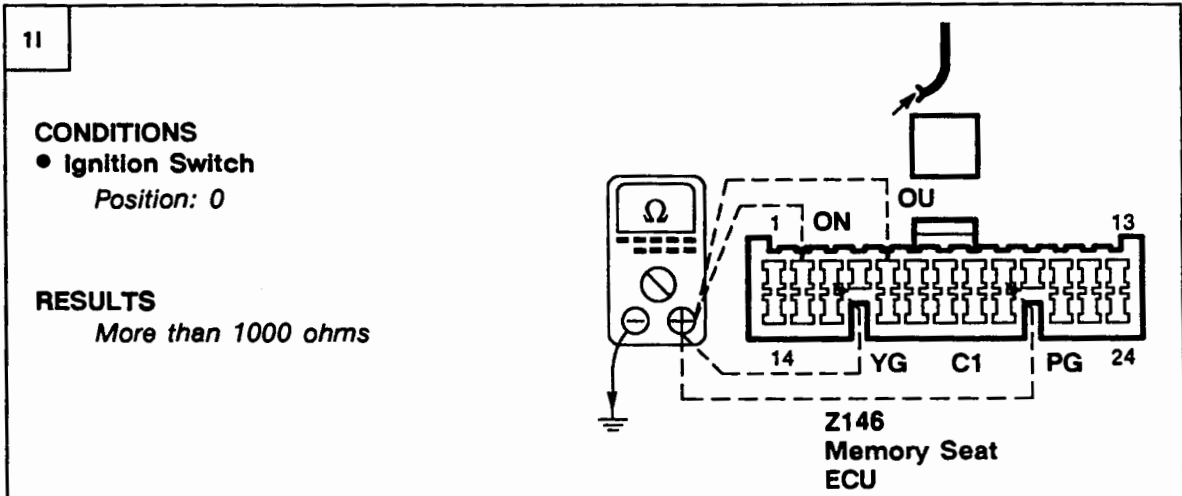

PROBLEM CAUSE

- OU Wire
- ON Wire
- YG Wire
- PG Wire
- Right Memory Mirror Actuator



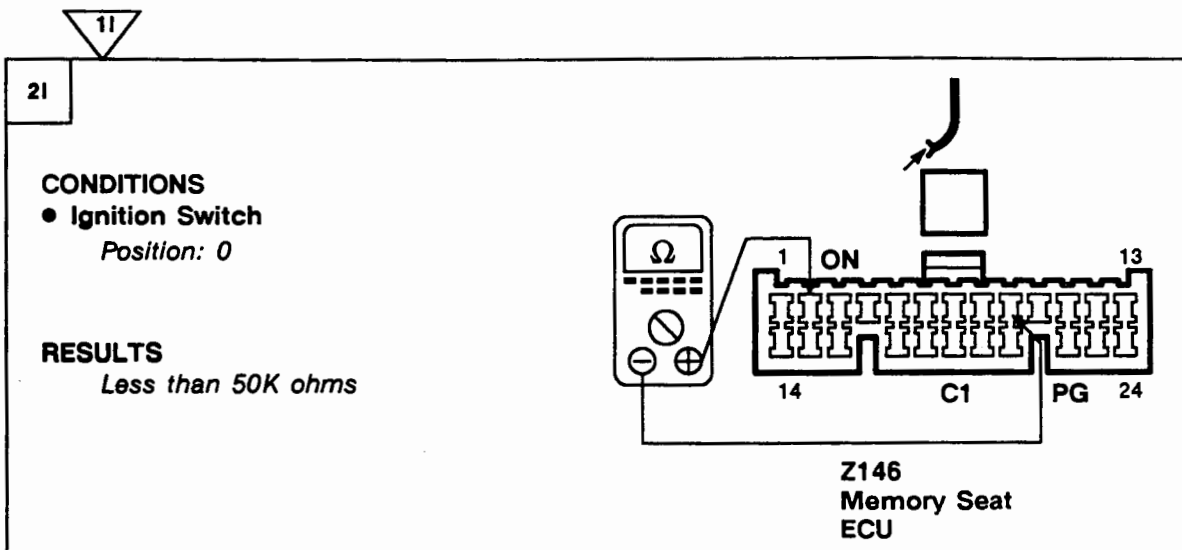

PROBLEM CAUSE

- ON Wire
- PG Wire
- Right Memory Mirror Actuator

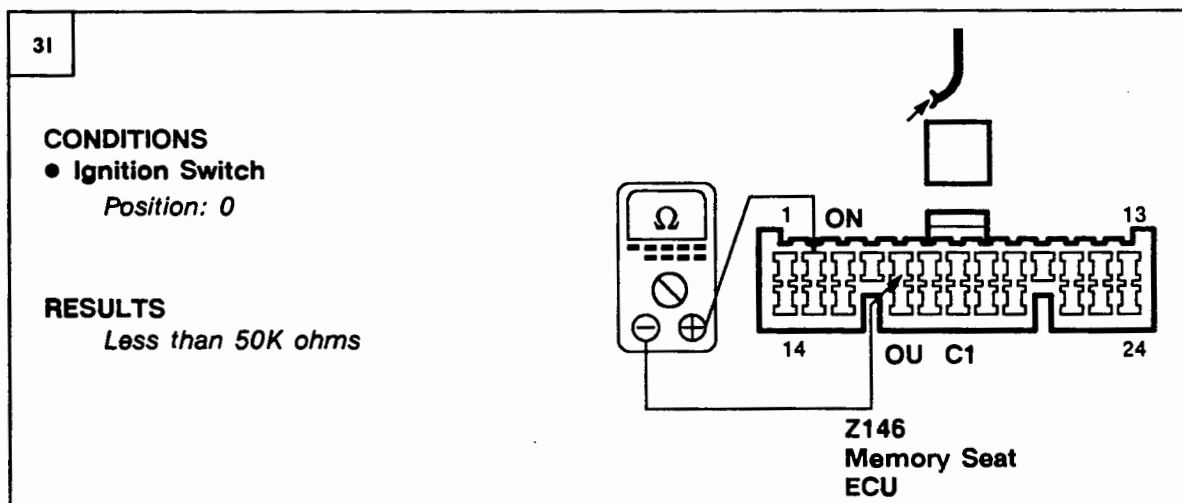

PROBLEM CAUSE

- OU Wire
- ON Wire
- Right Memory Mirror Actuator



PROBLEM CAUSE

- Memory Seat ECU

Test J

1J

CONDITIONS

- Ignition Switch
Position: I
- Driver's door
Open

RESULTS

- Driver Seat Control Switch
Forward
+BAT VOLT
- Backward*
-BAT VOLT

Z146
Memory Seat
ECU

PROBLEM CAUSE
- Memory Seat ECU

OK

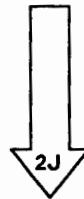

2J

CONDITIONS

- Ignition Switch
Position: I
- Driver's door
Open

RESULTS

- Driver Seat Control Switch
Rear up
-BAT VOLT
- Rear down*
+BAT VOLT

Z146
Memory Seat
ECU

PROBLEM CAUSE
- Memory Seat ECU

OK



M5 ETM

1992 RANGE ROVER

J2

J3

CONDITIONS

- Ignition Switch
Position: I
- Driver's door
Open

RESULTS

- Driver Seat Control Switch
Recline
+BAT VOLT
Raise
-BAT VOLT

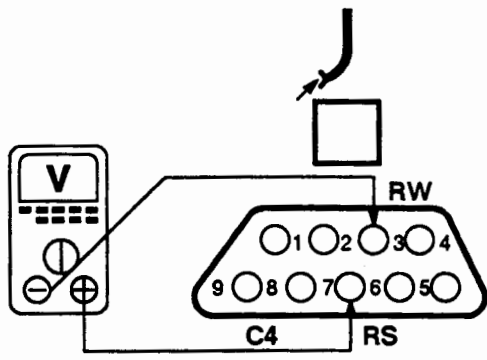

Z146
Memory Seat
ECU

OK PROBLEM CAUSE
- Memory Seat ECU

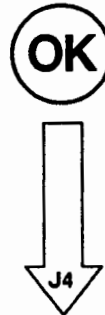

J4

CONDITIONS

- Ignition Switch
Position: I
- Driver's door
Open

RESULTS

- Driver Seat Control Switch
Front up
+BAT VOLT
Front down
-BAT VOLT

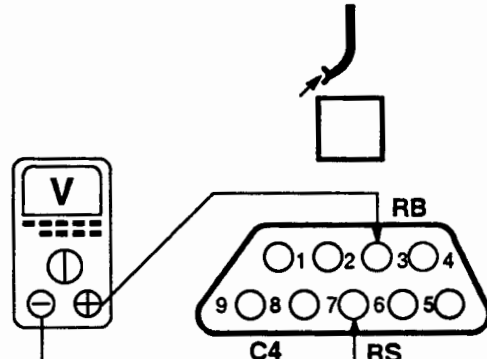

Z146
Memory Seat
ECU

OK PROBLEM CAUSE
- Memory Seat ECU

OK PROBLEM CAUSE
- Seat motors

Test K

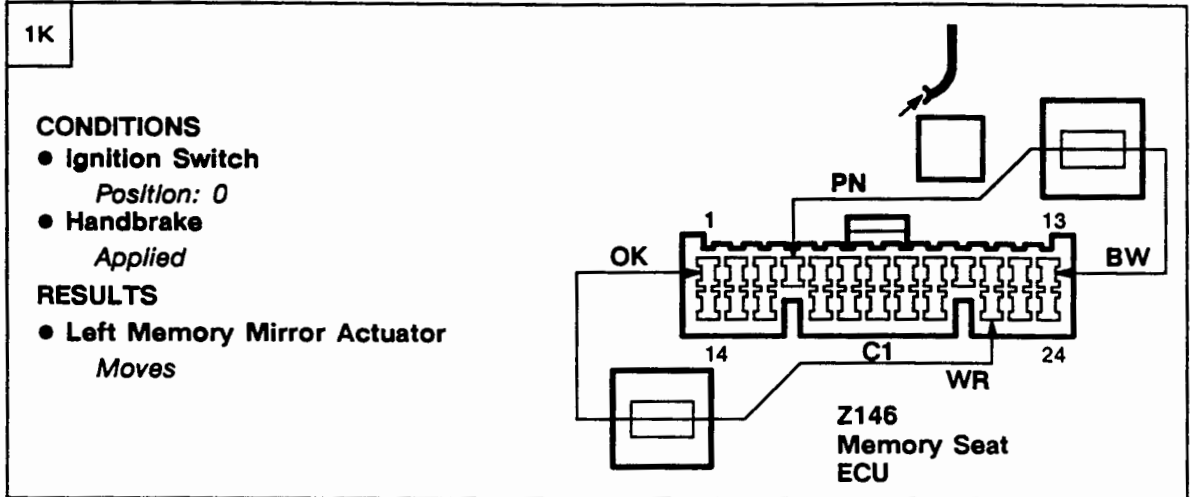

PROBLEM CAUSE

- WG Wire
- PR Wire
- PK Wire
- Left Memory Mirror Actuator

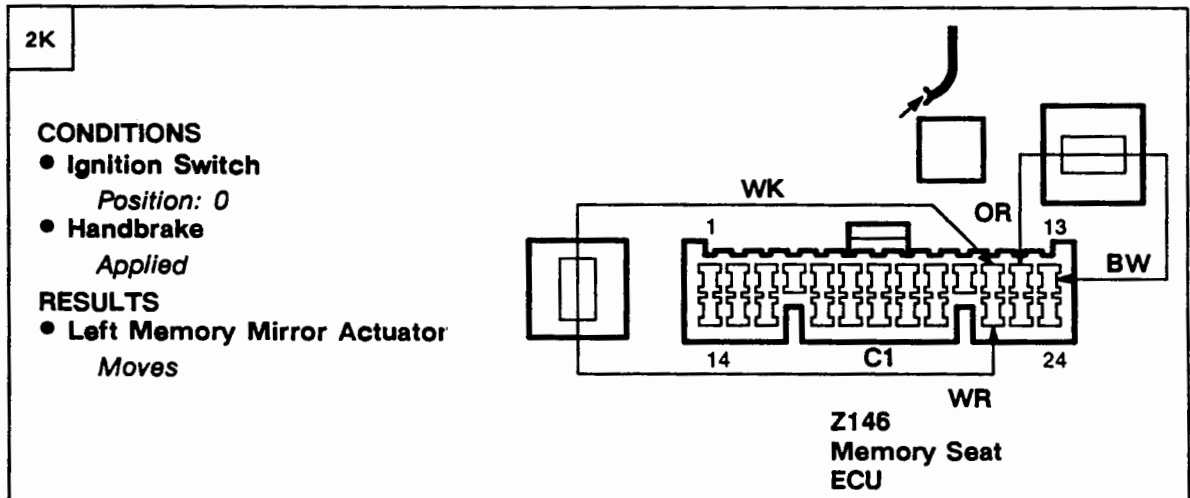

PROBLEM CAUSE

- WK Wire
- WP Wire
- OK Wire
- Left Memory Mirror Actuator



PROBLEM CAUSE

- Memory Seat ECU

Test L

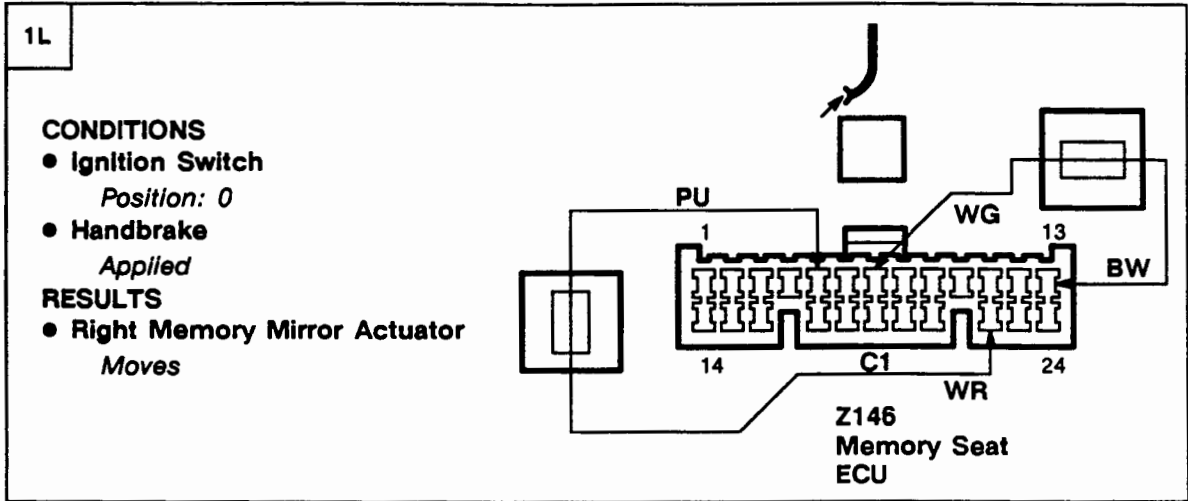

PROBLEM CAUSE

- WG Wire
- PU Wire
- PR Wire
- Right Memory Mirror Actuator

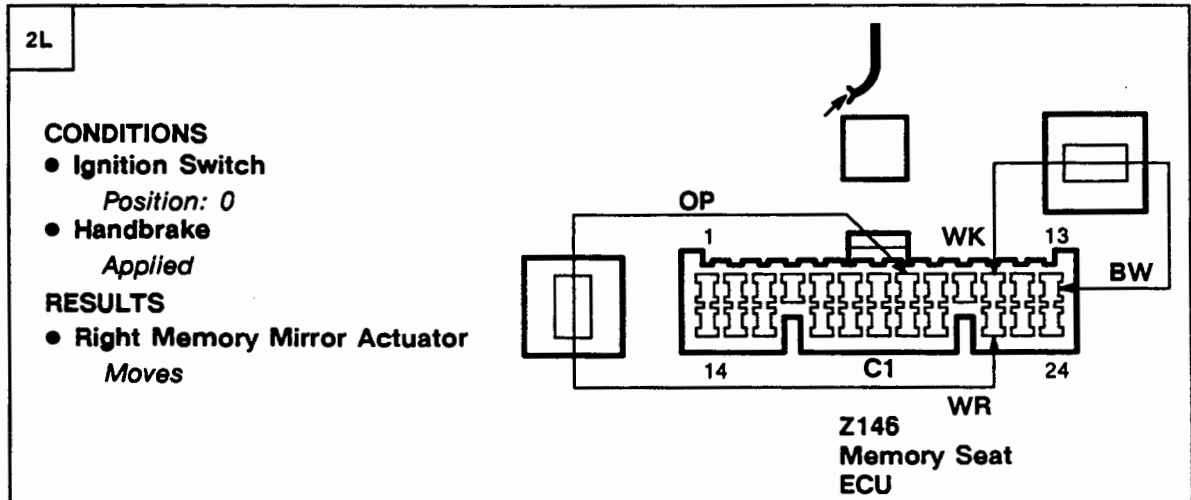

PROBLEM CAUSE

- OP Wire
- WK Wire
- WP Wire
- Right Memory Mirror Actuator



PROBLEM CAUSE

- Memory Seat ECU