

Wire Colour Chart

| | |
|-----------|-----------|
| B- Black | P- Purple |
| G- Green | R- Red |
| K- Pink | S- Grey |
| L- Light | U- Blue |
| N- Brown | W- White |
| O- Orange | Y- Yellow |

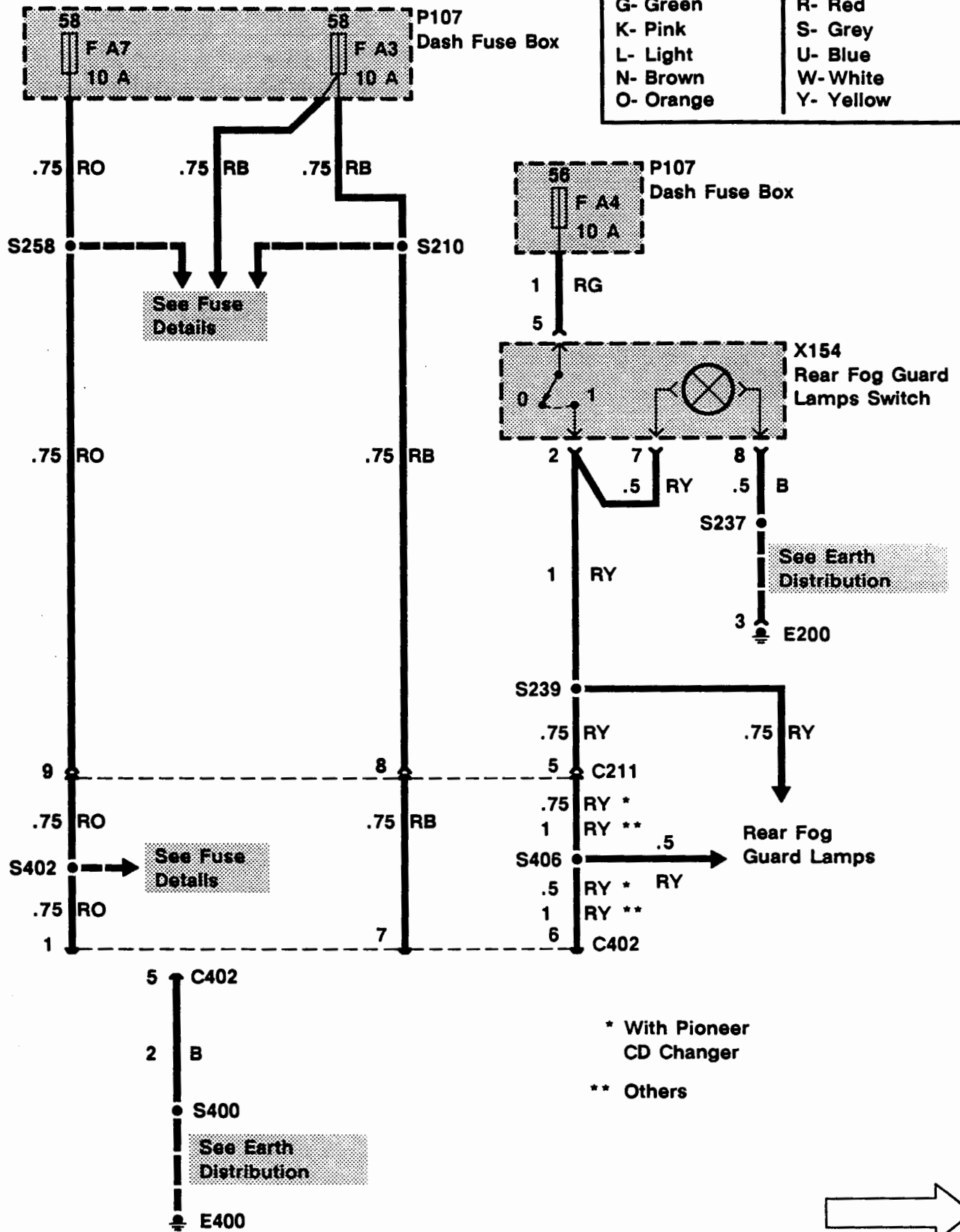

P1 ETM

1992 RANGE ROVER

Wire Colour Chart

| | |
|-----------|-----------|
| B- Black | P- Purple |
| G- Green | R- Red |
| K- Pink | S- Grey |
| L- Light | U- Blue |
| N- Brown | W- White |
| O- Orange | Y- Yellow |

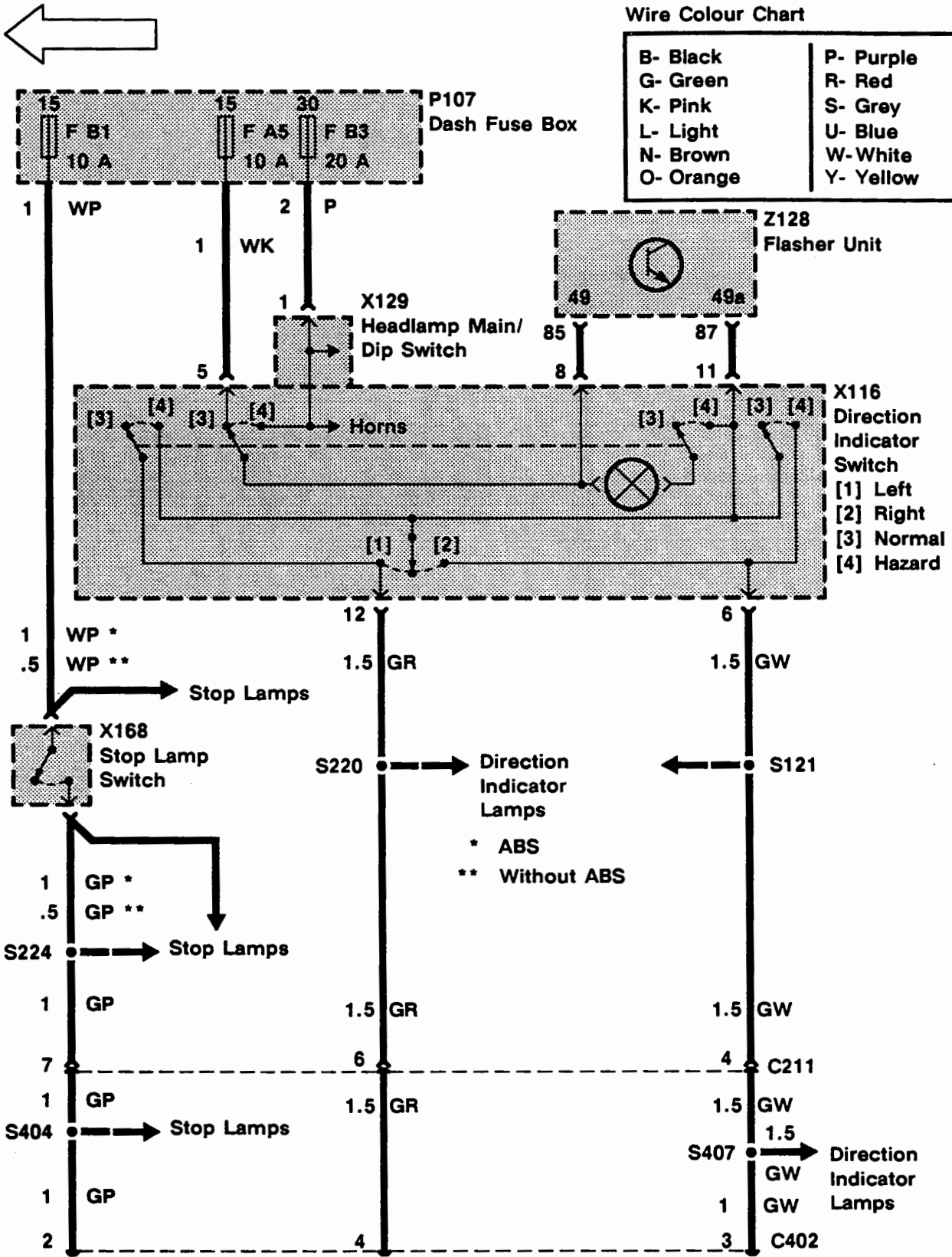

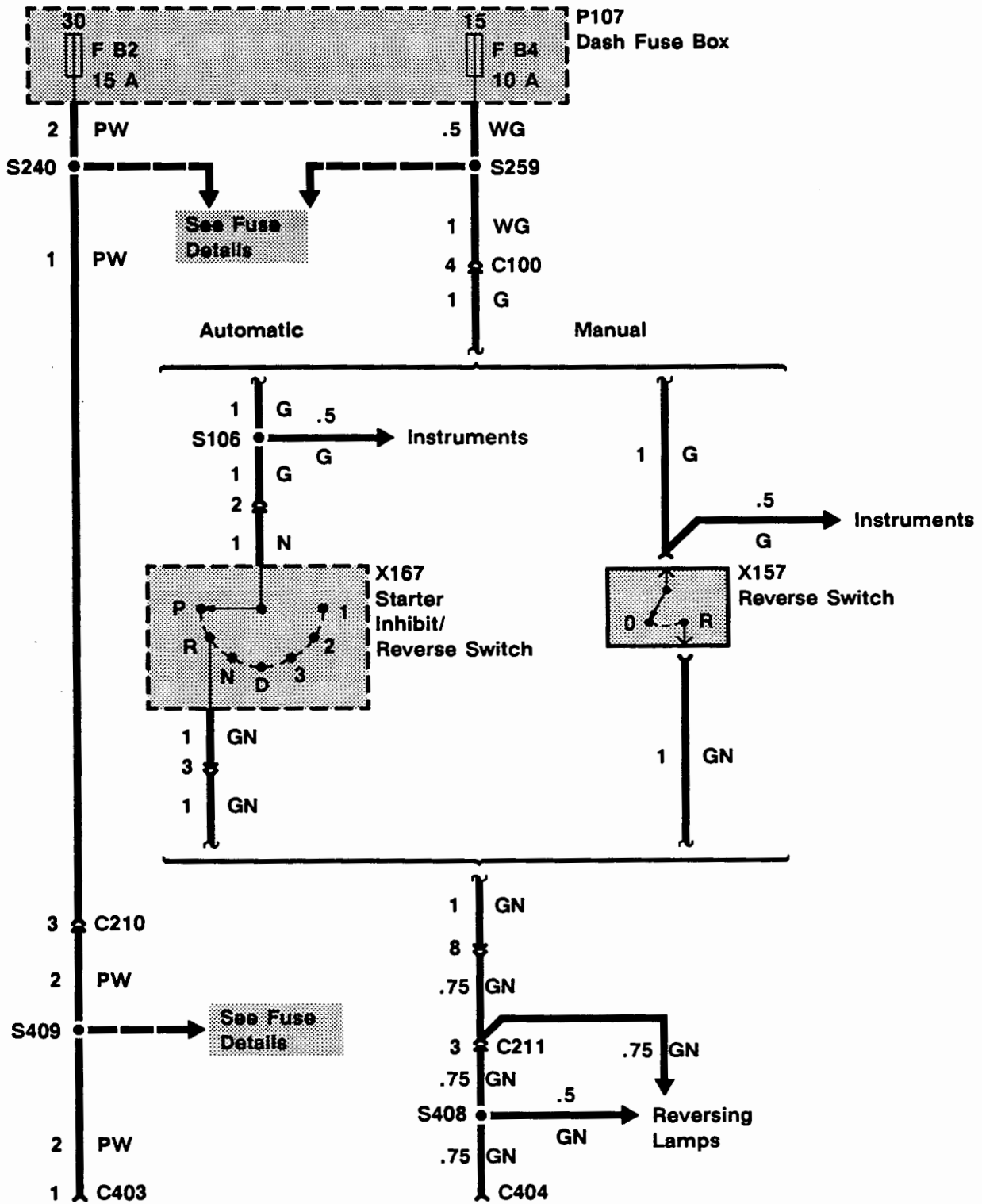
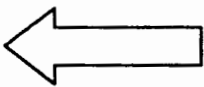

1992 RANGE ROVER

KEY INFORMATION

CIRCUIT DIAGRAMS

- Circuit diagrams are arranged so that current flow is from the top of the diagram (current source) to the bottom of the diagram (earth).
- Only those components that work together in the circuit are shown. If only part of a component is used in the circuit, then only that part of the component is shown.
- Remember:

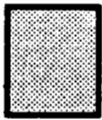

Entire component

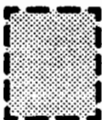

Part of a component

TERMINAL NUMBER

50

DESIGNATION

Battery voltage: Ignition Switch in position III

30

Battery voltage: supplied constantly

15

Battery voltage: Ignition Switch in position II or III

R

Battery voltage: Ignition Switch in positions I, II

31

Earth

See Introduction (i) for additional circuit diagram symbols.

DIAGNOSIS

- If the diagram is accompanied by text:
 - Read the Circuit Operation before proceeding with the electrical diagnosis.
 - Read the Troubleshooting Hints before performing the System Diagnosis.
 - Tests follow the System Diagnosis.
 - When performing the System Diagnosis, be certain that all components disconnected in previous steps are reconnected unless otherwise directed.



Component is disconnected.
Backprobe harness connector



Component is connected.
Backprobe harness connector



Component is disconnected.
Probe component

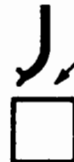

Component is disconnected.
Probe harness connector



Probe in-line connector



Wire Colour Chart

| | |
|-----------|-----------|
| B- Black | P- Purple |
| G- Green | R- Red |
| K- Pink | S- Grey |
| L- Light | U- Blue |
| N- Brown | W- White |
| O- Orange | Y- Yellow |

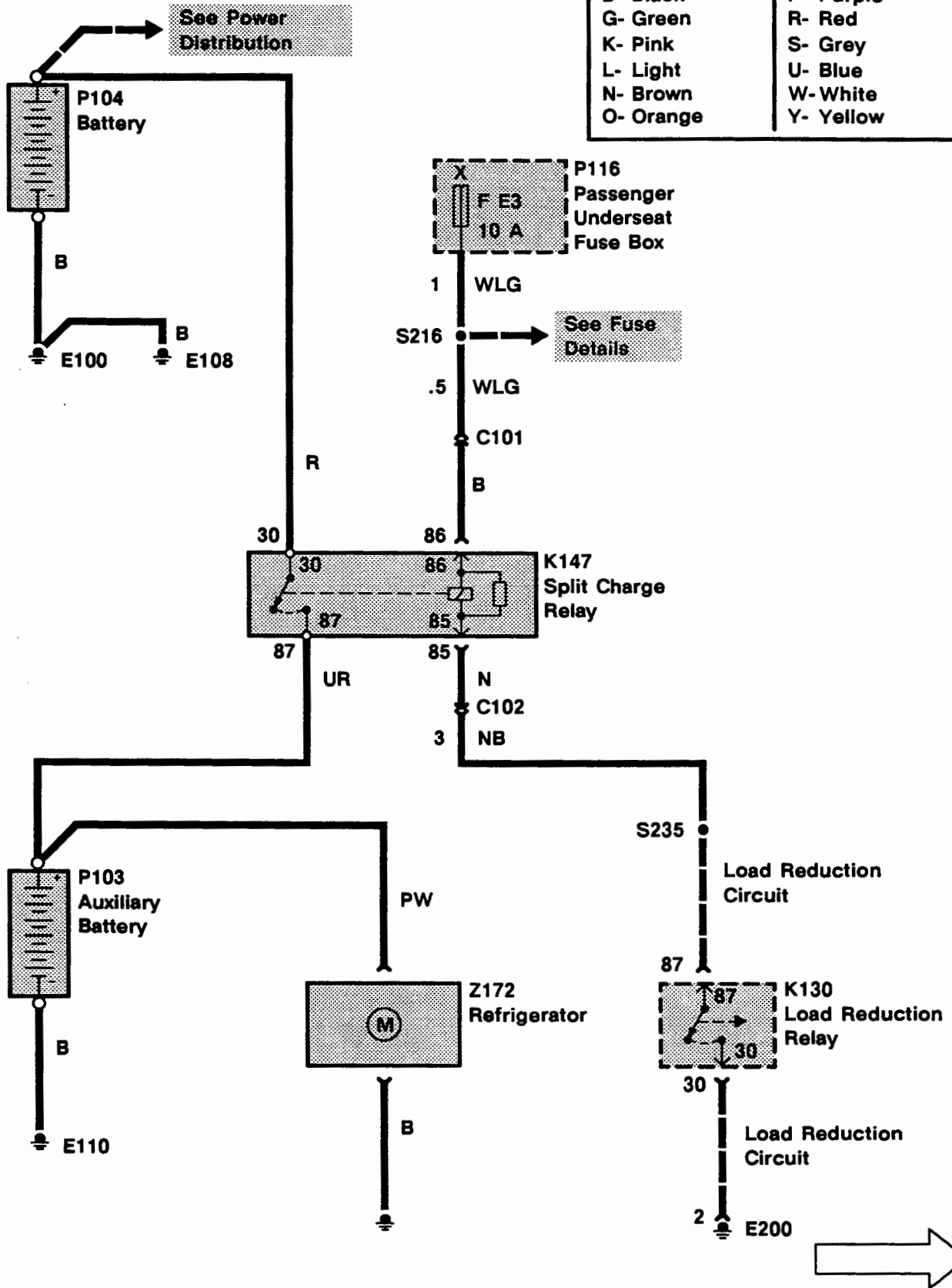

P2 ETM

1992 RANGE ROVER

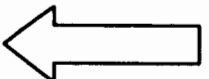

Wire Colour Chart

| | |
|-----------|-----------|
| B- Black | P- Purple |
| G- Green | R- Red |
| K- Pink | S- Grey |
| L- Light | U- Blue |
| N- Brown | W- White |
| O- Orange | Y- Yellow |

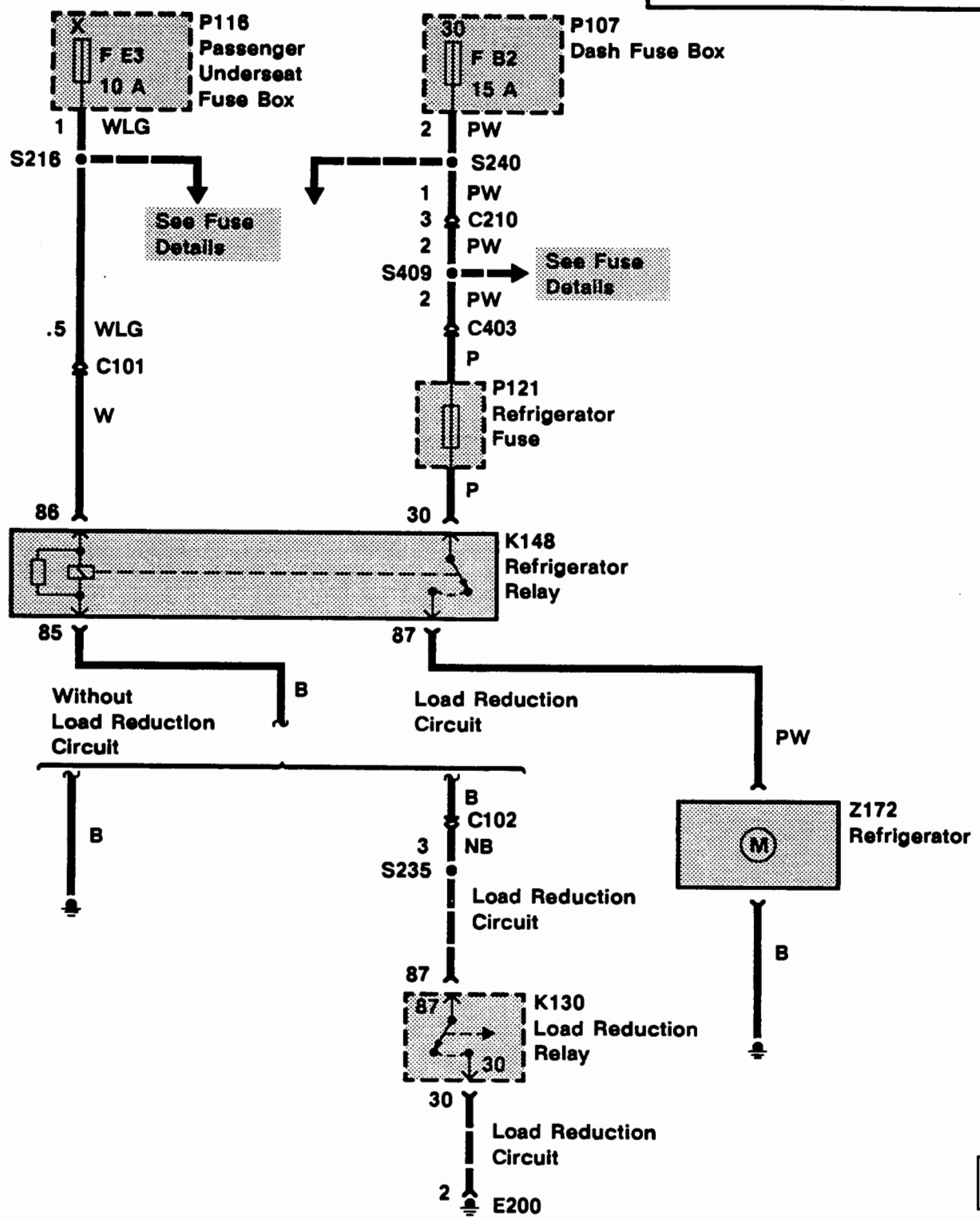

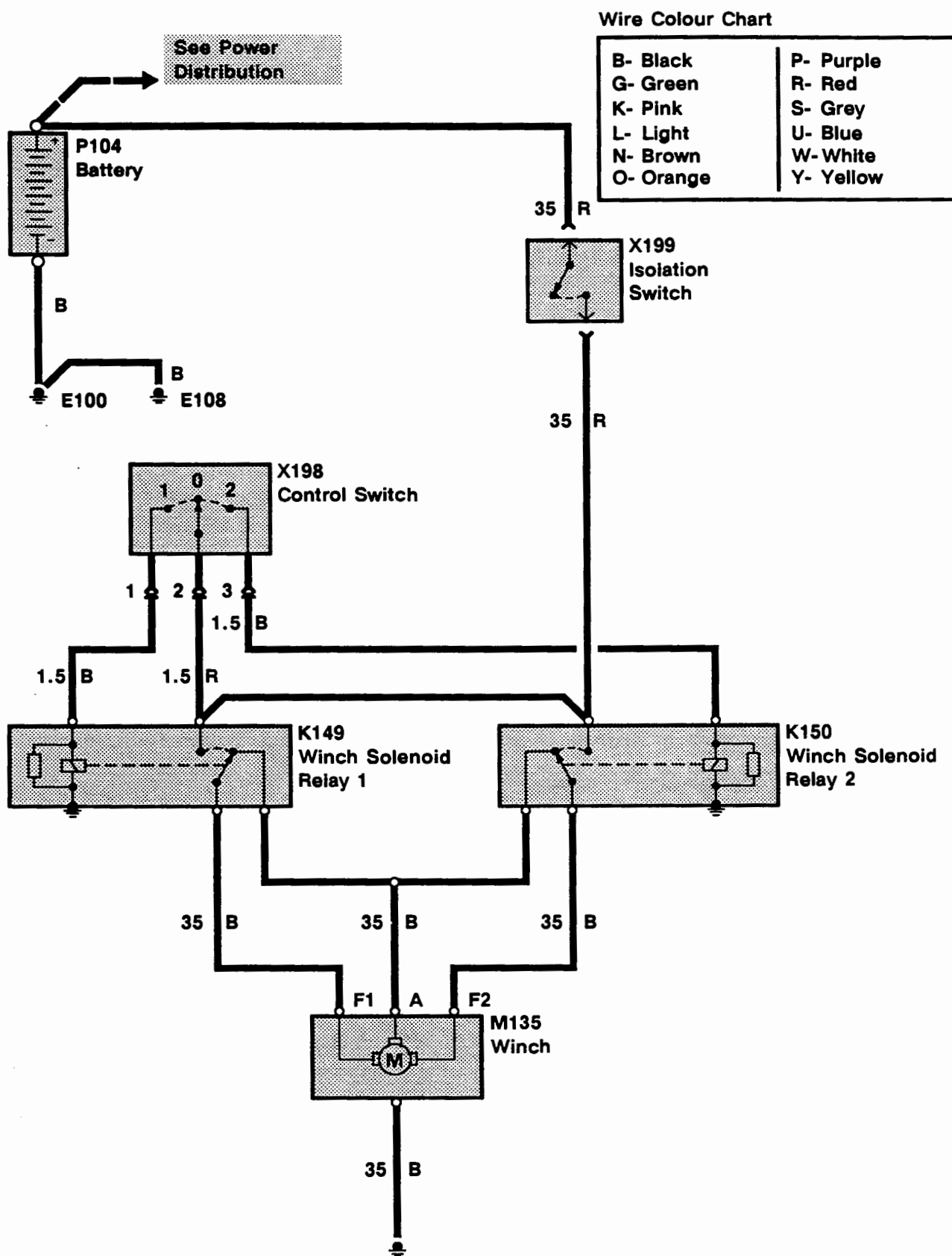

Wire Colour Chart

| | |
|-----------|-----------|
| B- Black | P- Purple |
| G- Green | R- Red |
| K- Pink | S- Grey |
| L- Light | U- Blue |
| N- Brown | W- White |
| O- Orange | Y- Yellow |

See Power Distribution

1992 RANGE ROVER

KEY INFORMATION

CIRCUIT DIAGRAMS

- Circuit diagrams are arranged so that current flow is from the top of the diagram (current source) to the bottom of the diagram (earth).
- Only those components that work together in the circuit are shown. If only part of a component is used in the circuit, then only that part of the component is shown.
- Remember:

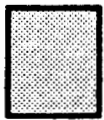

Entire component

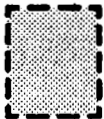

Part of a component

TERMINAL NUMBER

DESIGNATION

| | |
|----|--|
| 50 | Battery voltage: Ignition Switch in position III |
| 30 | Battery voltage: supplied constantly |
| 15 | Battery voltage: Ignition Switch in position II or III |
| R | Battery voltage: Ignition Switch in positions I, II |
| 31 | Earth |

See Introduction (i) for additional circuit diagram symbols.

DIAGNOSIS

- If the diagram is accompanied by text:
 - Read the Circuit Operation before proceeding with the electrical diagnosis.
 - Read the Troubleshooting Hints before performing the System Diagnosis.
 - Tests follow the System Diagnosis.
 - When performing the System Diagnosis, be certain that all components disconnected in previous steps are reconnected unless otherwise directed.



Component is disconnected.
Backprobe harness connector

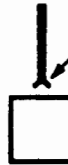

Component is connected.
Backprobe harness connector

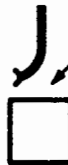

Component is disconnected.
Probe component



Component is disconnected.
Probe harness connector



Probe in-line connector