

**CIRCUIT OPERATION**

Voltage for window lift and sunroof operation is provided to the Window Lift ECU (Z147) from fuses C2 and C8. The Window Lift ECU is grounded through the B wire at ground E302.

**Timeout Feature**

Fuse E6 applies voltage to the Window Lift ECU terminal 4 when the ignition switch is on. When the ignition switch is turned off, the absence of voltage at terminal 4 signals the Window Lift ECU to start the timeout feature. When the timeout feature is activated, the Window Lift ECU will allow window and sunroof operation for an additional 45 seconds.

The timeout feature will be cancelled if the driver's door is opened and then closed on all models except NAS models. On NAS models, the feature is cancelled as soon as any door is opened. The Window Lift ECU monitors the door's position at terminal 14.

If Window Lift ECU terminals 8 and 13 are not connected together, the system operates in the NAS mode.

**Front Window Operation**

When a Front Window Switch is operated, the switch grounds one of four Window Lift ECU input terminals. This signals the Window Lift ECU to apply voltage and ground to the respective window motor. If the front window switch is held in the down position for more than 1/2 second, the express down feature is activated. The Window Lift ECU will operate the window motor until it is completely lowered.

**Rear Window**

The Window Lift ECU terminal 2 supplies voltage to the Rear Window Console and door switches for rear window operation.

When a window console switch is in the DOWN position, voltage is applied to the window motor through the 'down' switch contacts. The window motors operate because they are grounded through the 'up' contacts of the window console switch. When a switch is in the UP position, the polarity applied to the window motor is reversed, causing the motor to run in the opposite direction and the window to close.

**Rear Window Isolation Switch (X187)**

The Rear Window Isolation Switch (X187) is placed in series with the voltage supply to the Rear Window Door Switches (X188, X189). If the isolation switch is opened, the voltage is interrupted, preventing rear window operation using the rear door switches.

Wire Colour Chart

B- Black	P- Purple
G- Green	R- Red
K- Pink	S- Grey
L- Light	U- Blue
N- Brown	W- White
O- Orange	Y- Yellow

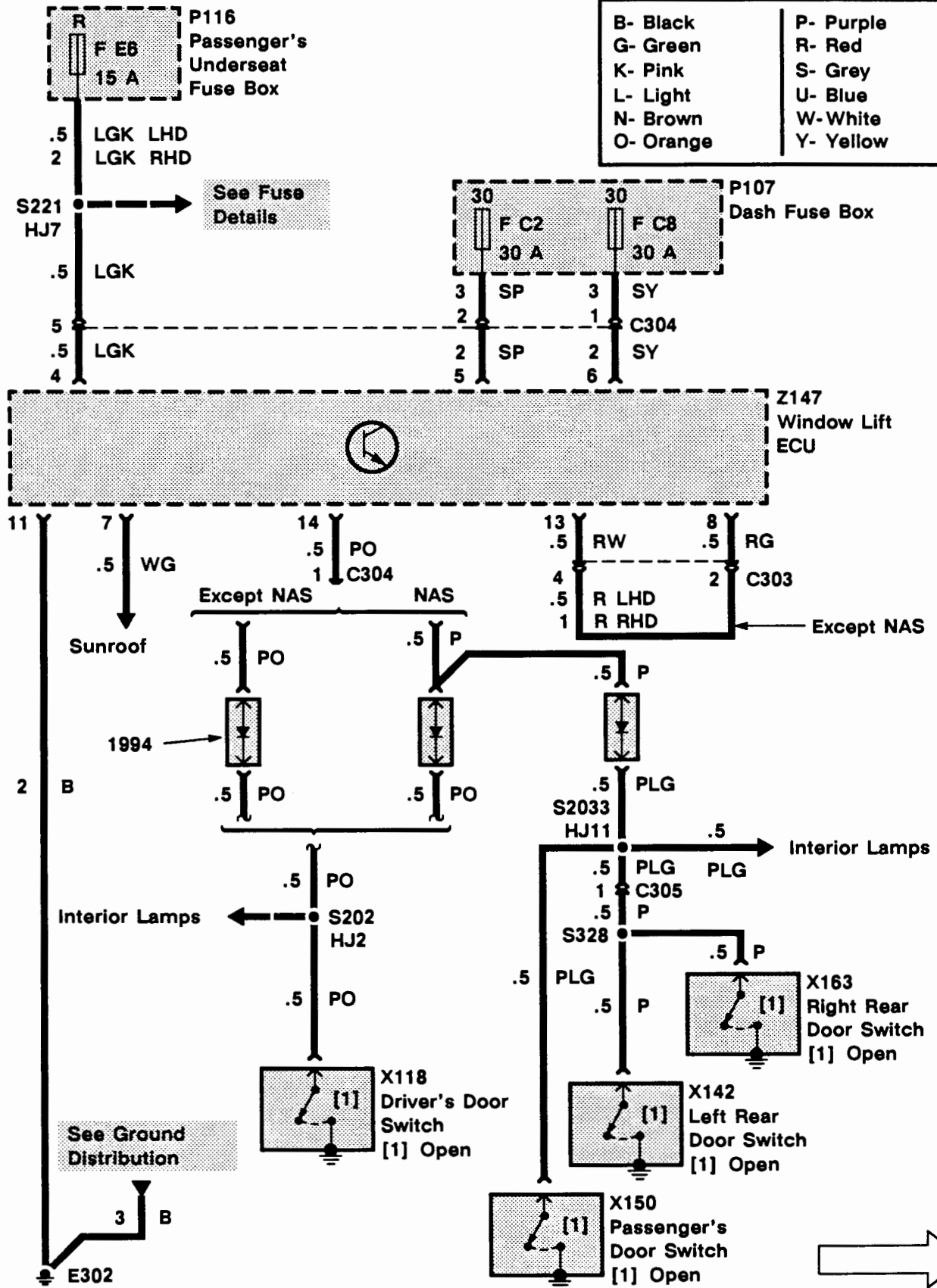

REV: AUG 93

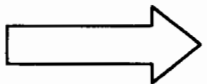
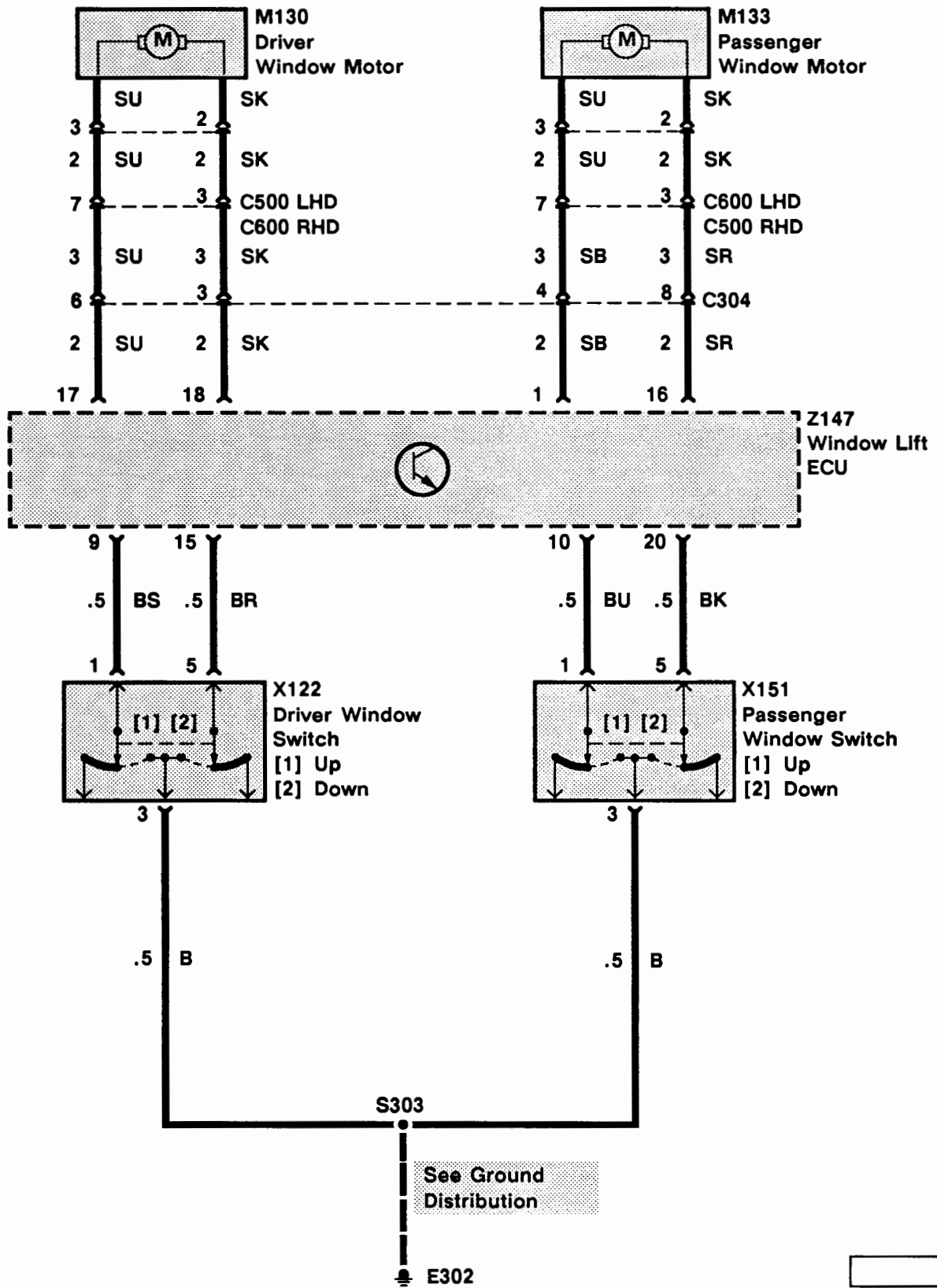
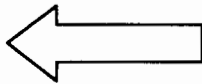

# L1 ETM

## 1993 RANGE ROVER

### Wire Colour Chart

B- Black	P- Purple
G- Green	R- Red
K- Pink	S- Grey
L- Light	U- Blue
N- Brown	W- White
O- Orange	Y- Yellow

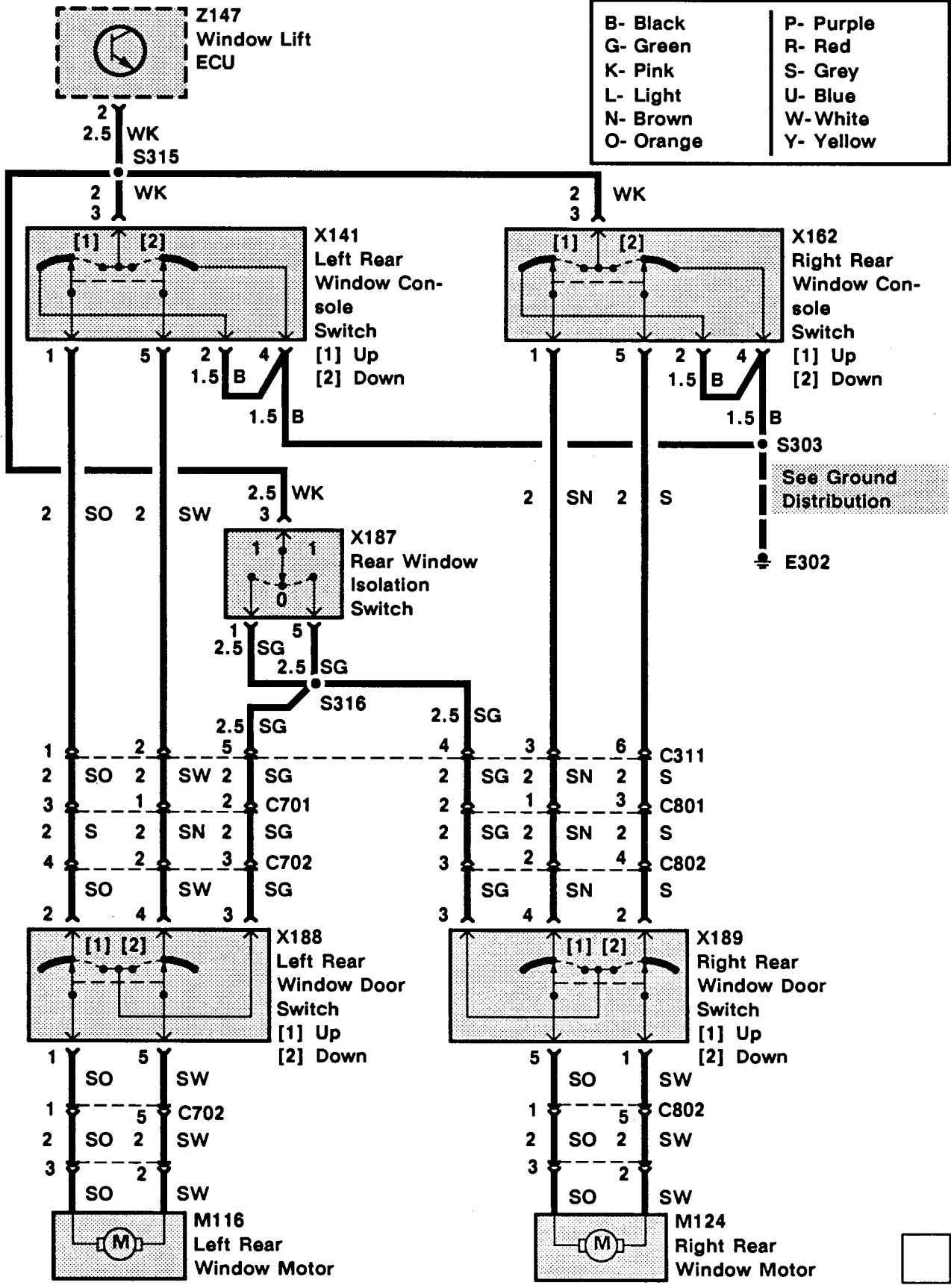

**TROUBLESHOOTING HINTS**

1. If the one touch window feature does not operate but the window operates, replace the Window Lift ECU (Z147).

**SYSTEM DIAGNOSIS**

1. If none of the windows operate, do Test A.
2. If both rear windows do not operate from the rear door switches but do operate when the centre console switches are used, do test B.
3. If the rear windows do not operate from the centre console switches and the rear door switches, do Test C.
4. If one rear window does not operate from the centre console and door switch, do Test D.
5. If a rear window does not operate using the door switch but does operate from the centre console switch, do Test F.
6. If a rear window does not operate from the centre console switch but does work when the door switch is used, do Test E.
7. If a front window does not operate, do Test G.
8. All except NAS. If the window timeout feature does not operate, do test H.
9. All except NAS. If the window timeout occurs before 45 seconds have elapsed and before the driver's door is closed, do test I.
10. NAS only. If the window timeout feature does not operate do test J.

Test A

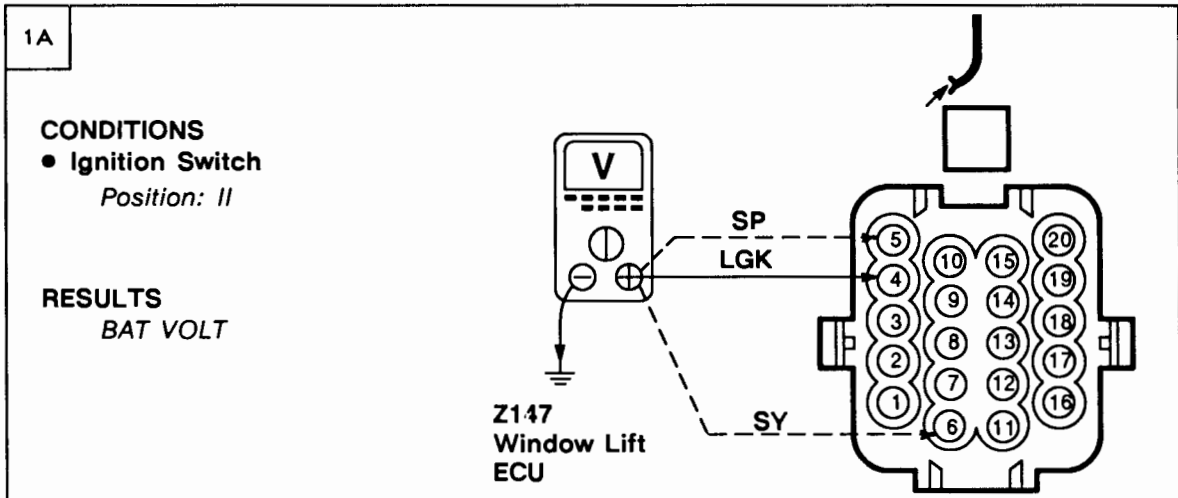

**PROBLEM CAUSE**

- F E6 Fuse
- LGK Wire
- F C2 Fuse
- SP Wire
- F C8 Fuse
- SY Wire

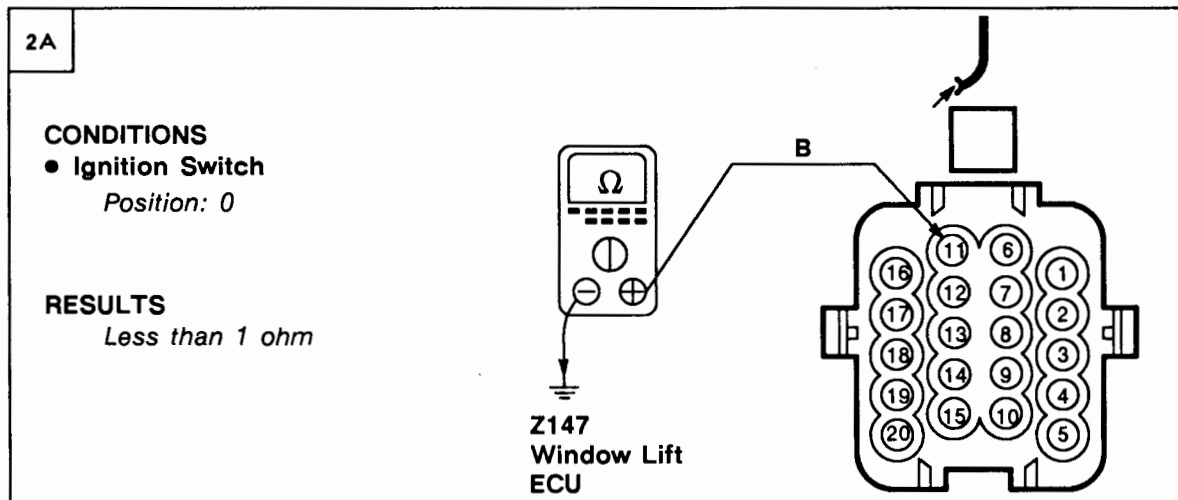

**PROBLEM CAUSE**

- B Wire
- E302



**PROBLEM CAUSE**

- Window Lift ECU

**Test B**

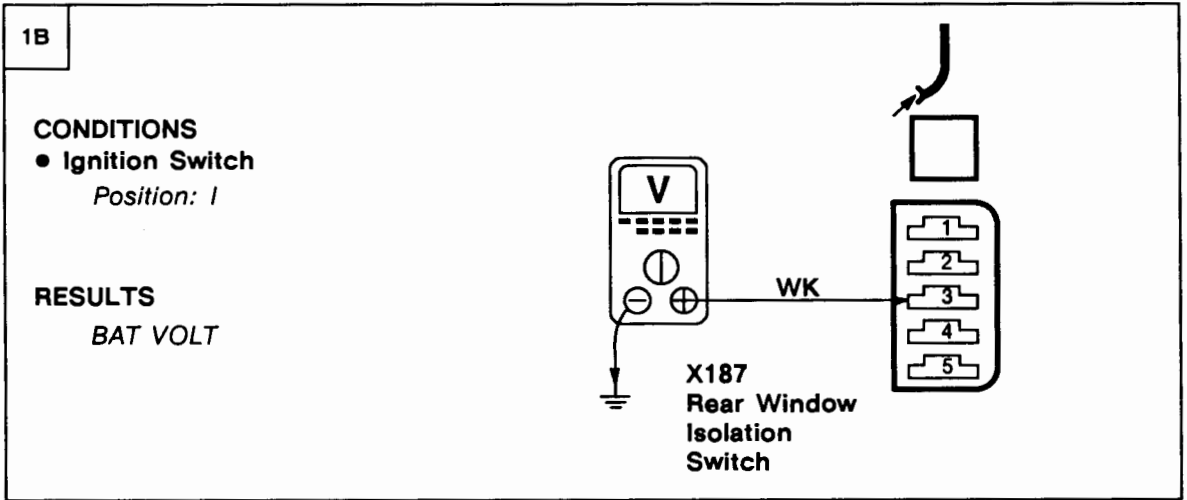

~~OK~~ PROBLEM CAUSE  
 - WK Wire

OK

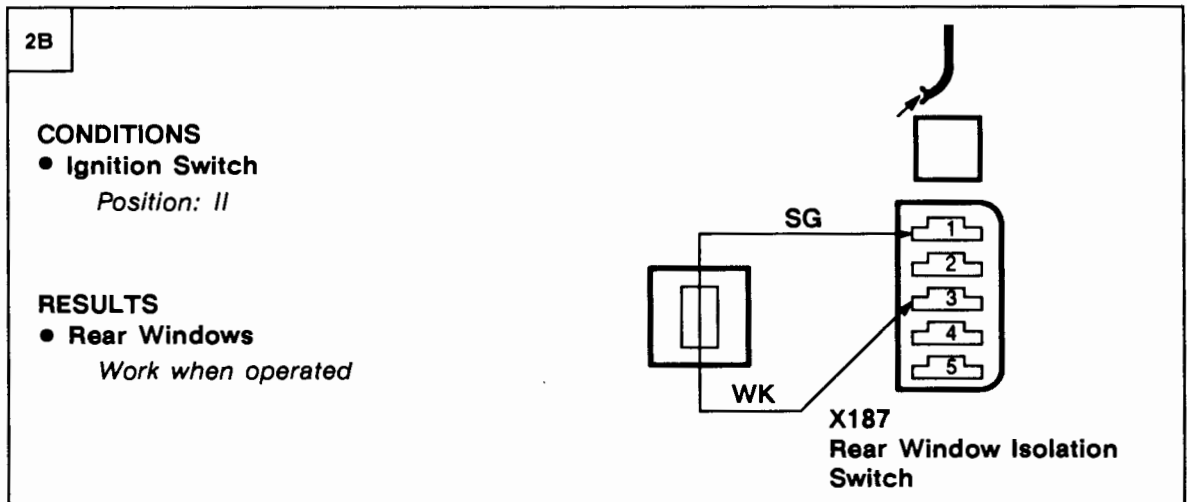
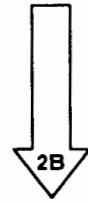

~~OK~~ PROBLEM CAUSE  
 - SG Wire

OK PROBLEM CAUSE  
 - Rear Window Isolation  
 Switch

**L1 ETM**

1993 RANGE ROVER

Test C

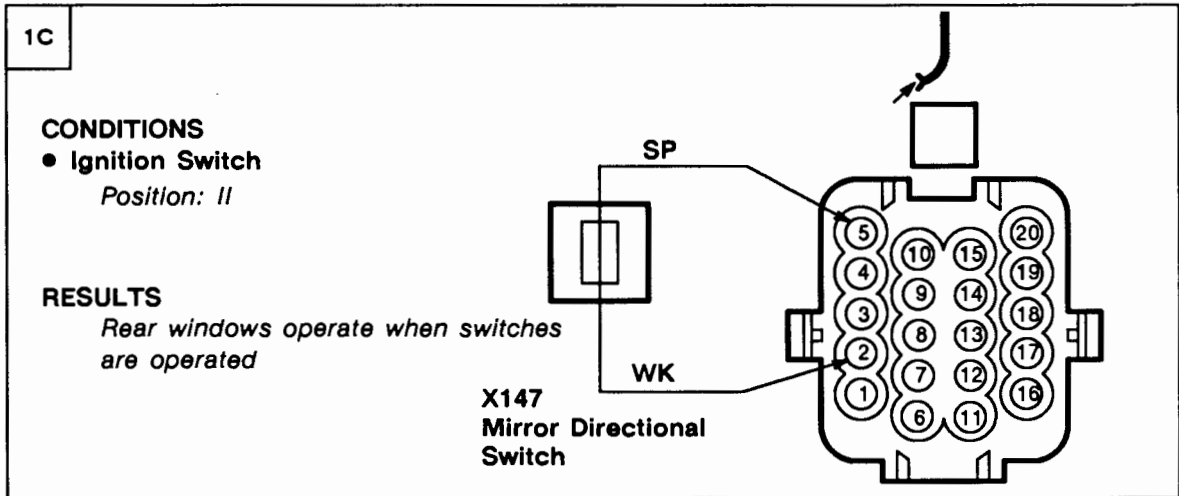

**PROBLEM CAUSE**  
 - WK Wire



**PROBLEM CAUSE**  
 - Window Lift ECU

Test D

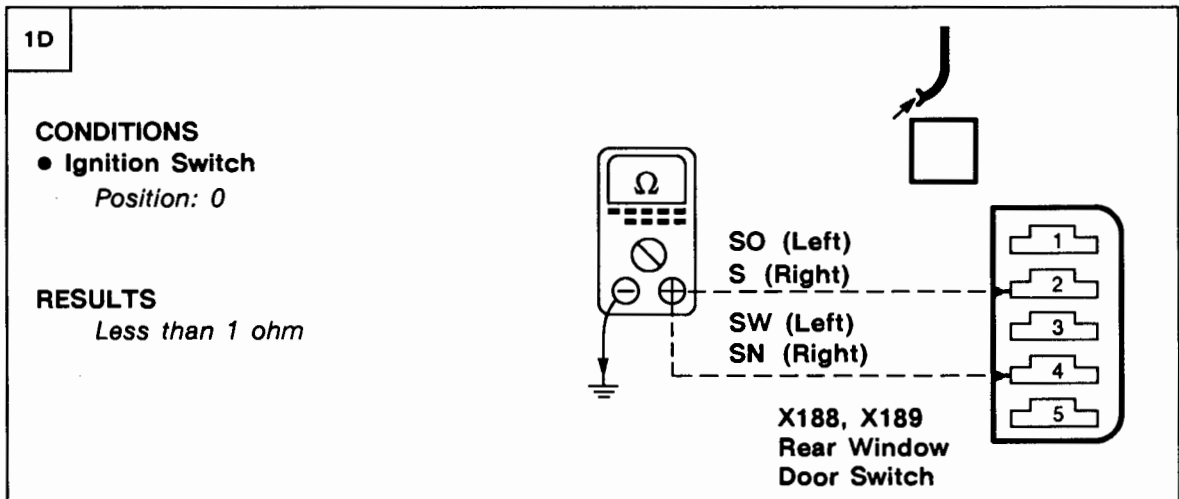

**GO TO TEST E**

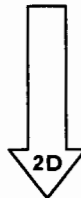



1D

2D

**CONDITIONS**

- Ignition Switch  
Position: 0

**RESULTS**

Less than 1 ohm

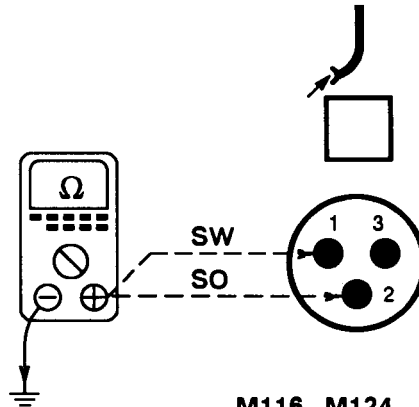

M116, M124  
Rear Window  
Motor



**PROBLEM CAUSE**

- SW Wire
- SO Wire
- X188, X189 Rear Window Door Switch



3D

**CONDITIONS**

- Ignition Switch  
Position: II

**RESULTS**

↕ = BAT VOLT  
OFF = 0 VOLT

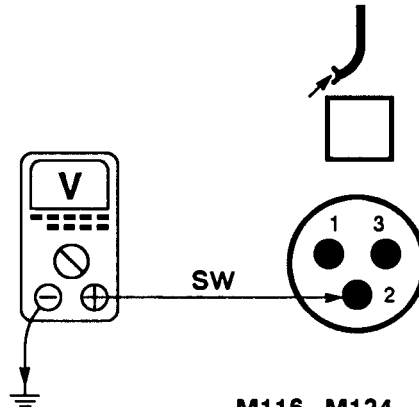

M116, M124  
Rear Window  
Motor



**PROBLEM CAUSE**

- SW Wire
- X188, X189 Rear Window Door Switch



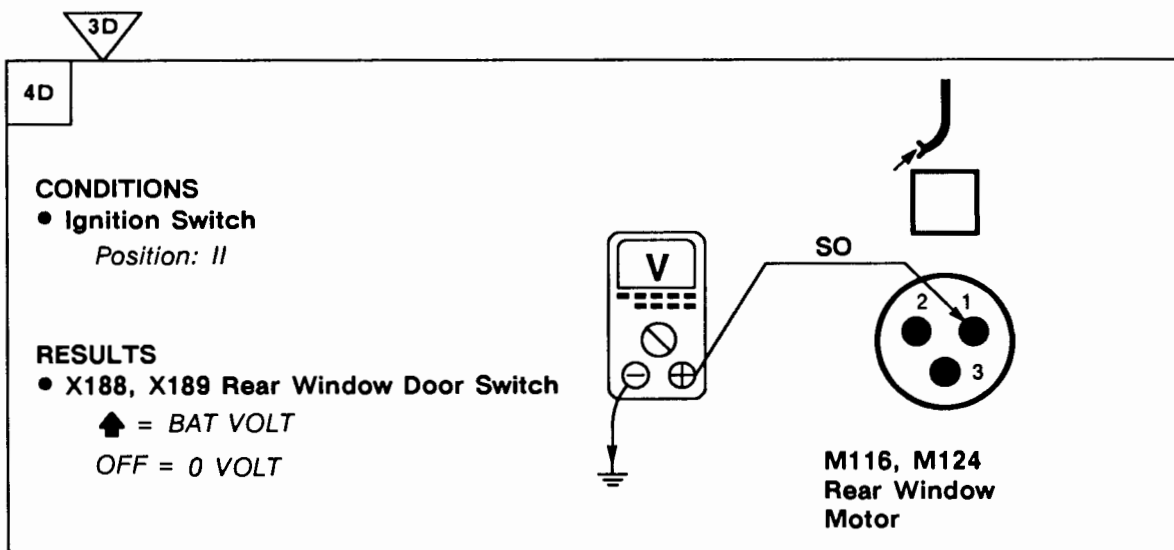

**PROBLEM CAUSE**

- SO Wire
- X188, X189 Rear Window Door Switch



**PROBLEM CAUSE**

- M116, M124 Rear Window Motor

**Test E**

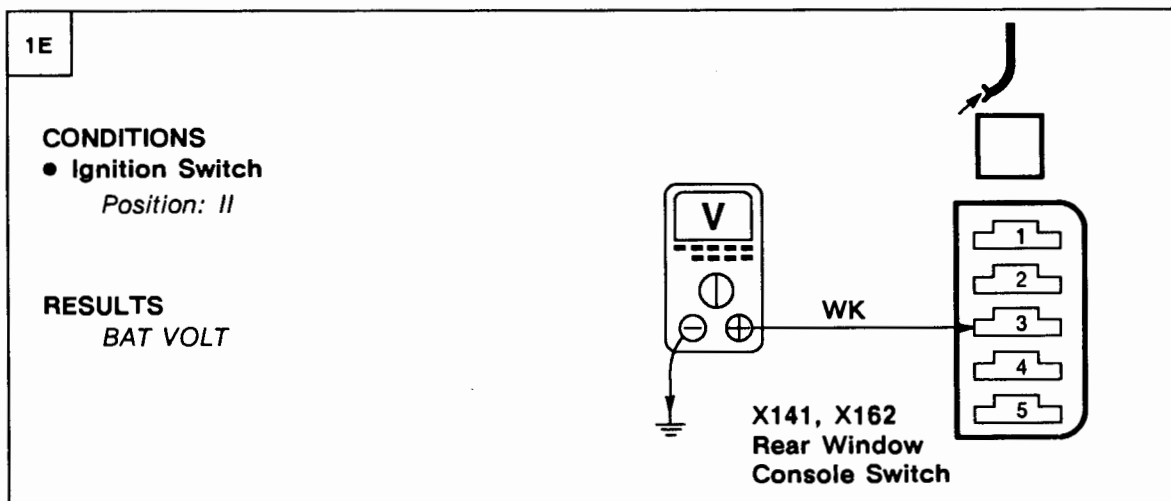

**PROBLEM CAUSE**

- WK Wire

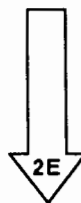

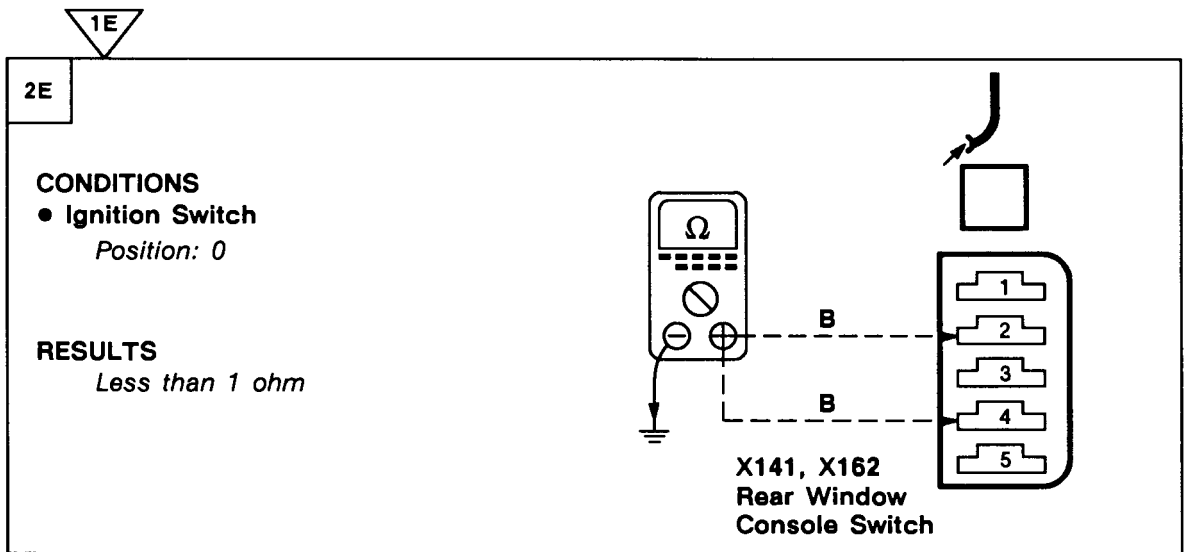

**OK** PROBLEM CAUSE  
- B Wire

**OK** PROBLEM CAUSE  
- X141, X162 Rear Window  
Console Switch

**Test F**

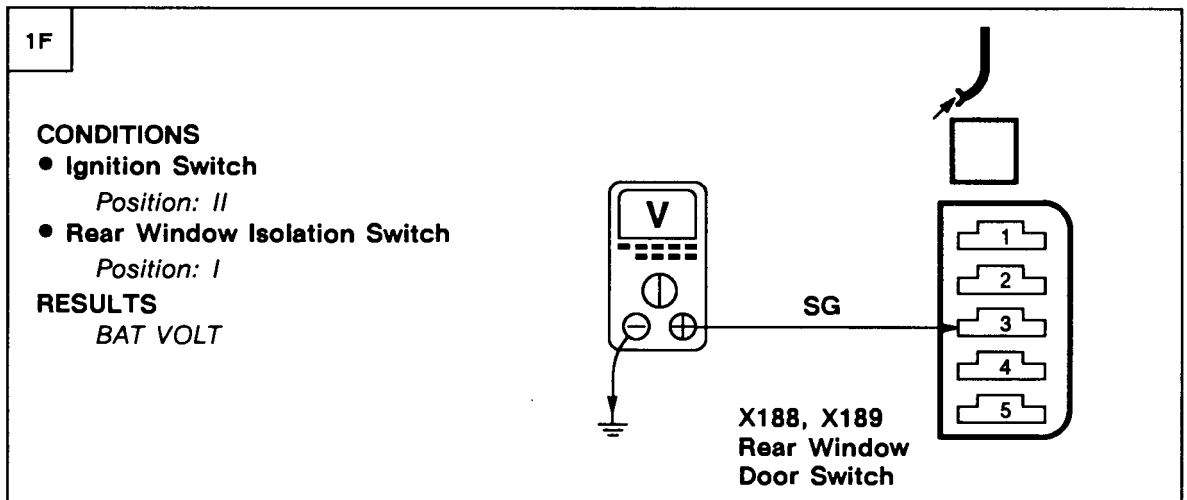

**OK** PROBLEM CAUSE  
- SG Wire

**OK** PROBLEM CAUSE  
- X188, X189 Rear Window  
Door Switch

Test G

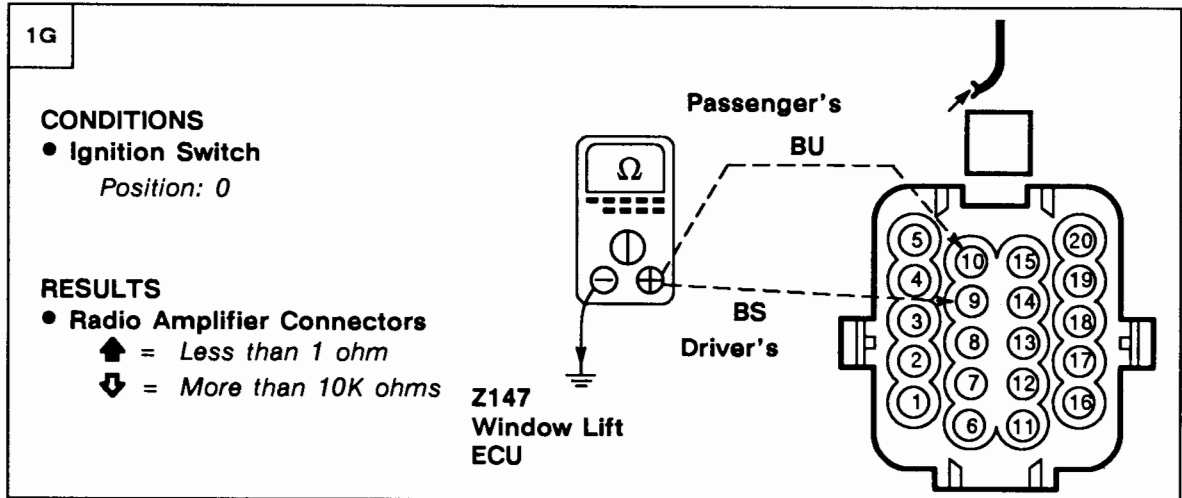

GO TO TEST H

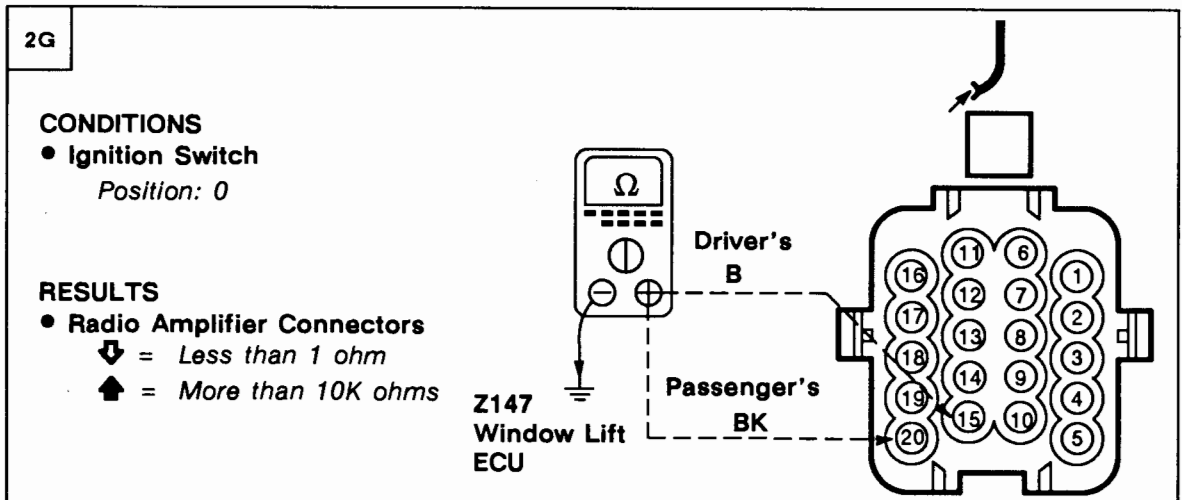
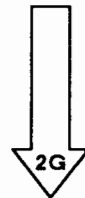

GO TO TEST H

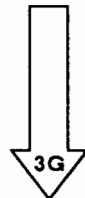

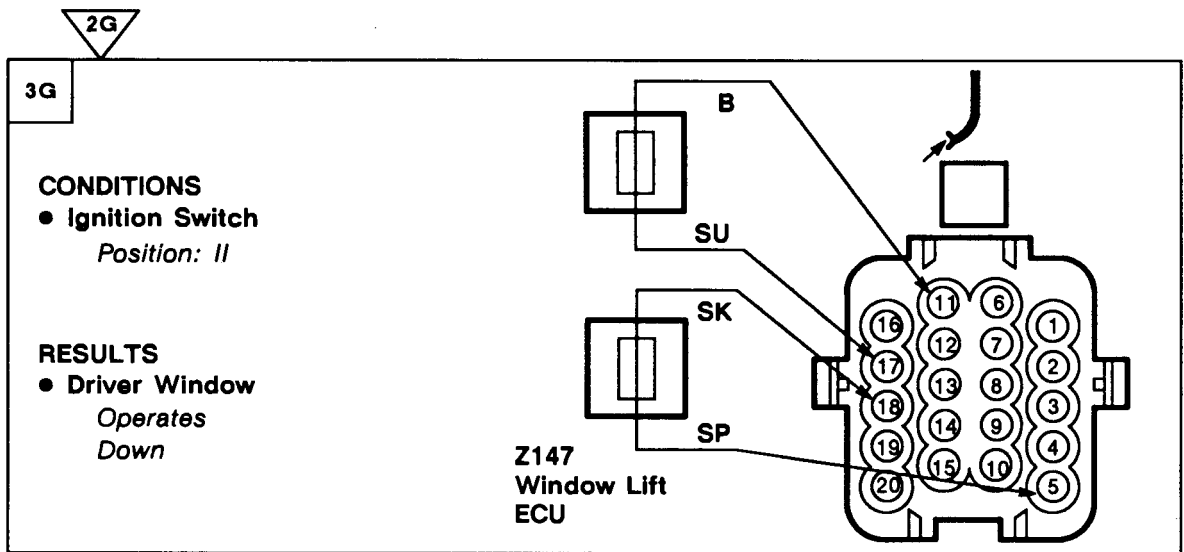

**PROBLEM CAUSE**

- SU Wire
- SK Wire
- Driver Window Motor

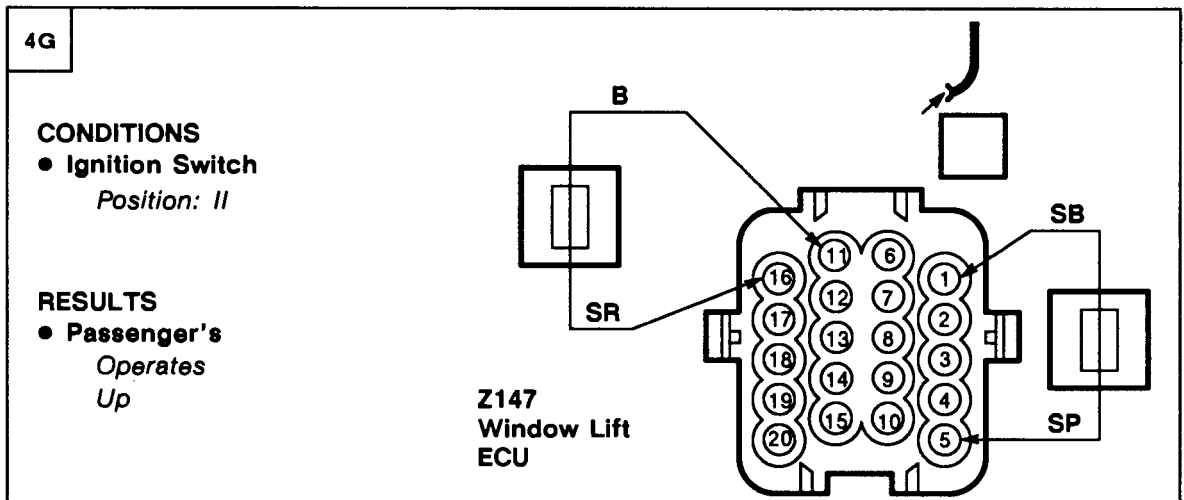
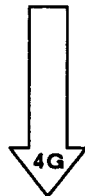

**PROBLEM CAUSE**

- SB Wire
- SR Wire
- Passenger Window Motor



**PROBLEM CAUSE**

- Window Lift ECU

**Test H**

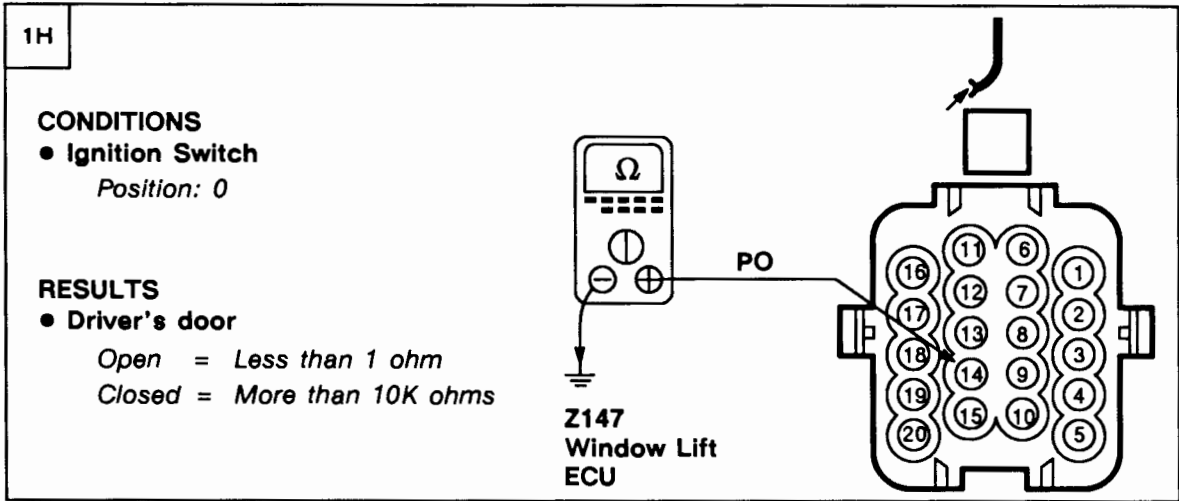

**PROBLEM CAUSE**  
 - PO Wire  
 - Driver Door Switch



**PROBLEM CAUSE**  
 - Window Lift ECU

**Test I**

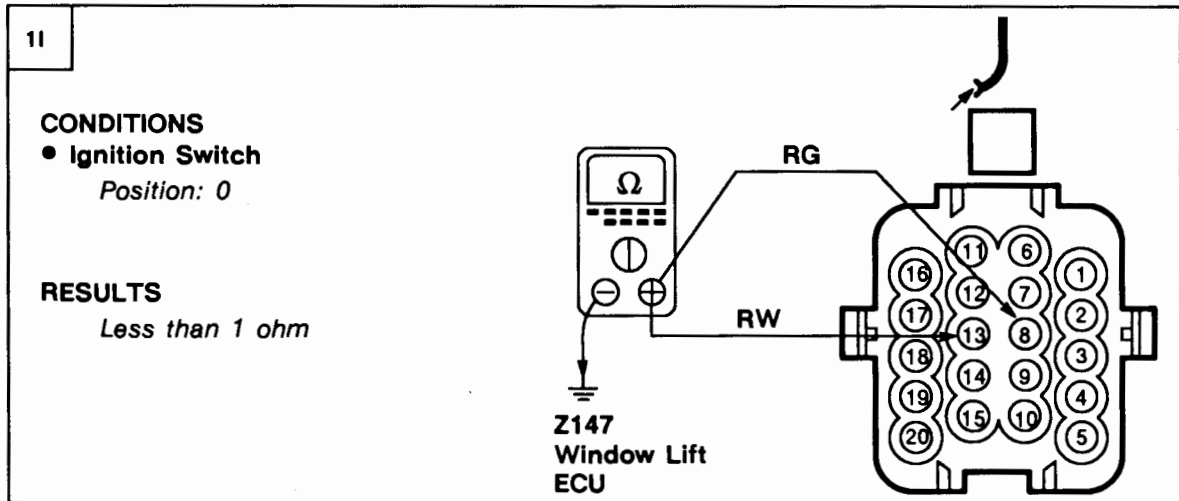

**PROBLEM CAUSE**  
 - RW Wire  
 - R Wire  
 - RE Wire



**PROBLEM CAUSE**  
 - Window Lift ECU

**Test J**

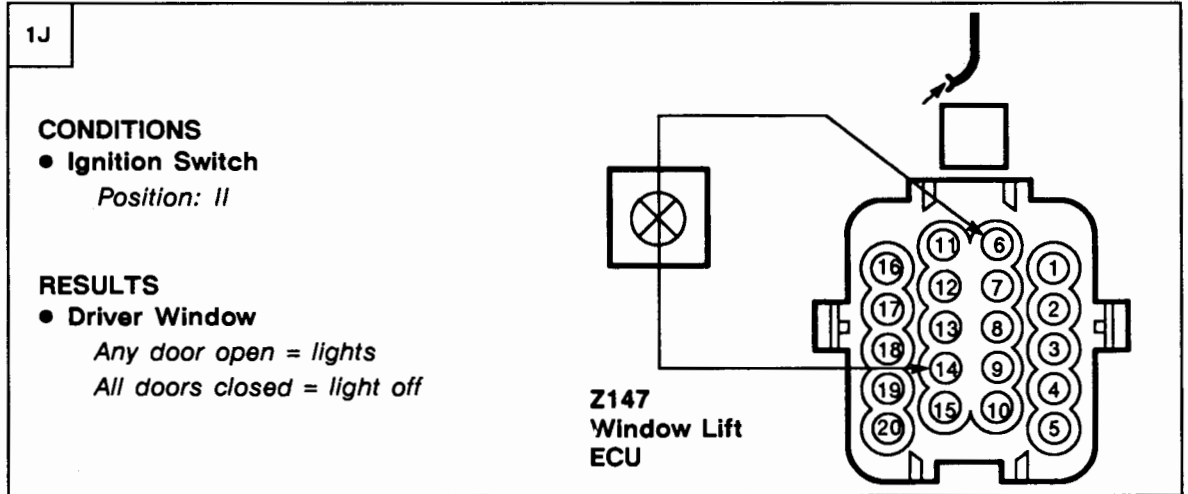

**PROBLEM CAUSE**

- PO Wire
- P Wire
- PLG Wire
- Front door switch
- Rear door switch



- PROBLEM CAUSE**
- Window Lift ECU

# 1993 RANGE ROVER

## KEY INFORMATION

### CIRCUIT DIAGRAMS

- Circuit diagrams are arranged so that current flow is from the top of the diagram (current source) to the bottom of the diagram (ground).
- Only those components that work together in the circuit are shown. If only part of a component is used in the circuit, then only that part of the component is shown.

#### ● Remember:

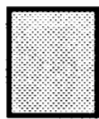

Entire component

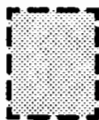

Part of a component

TERMINAL NUMBER	DESIGNATION
50	Battery voltage: Ignition Switch in position III
30	Battery voltage: supplied constantly
15	Battery voltage: Ignition Switch in position II or III
R	Battery voltage: Ignition Switch in positions I, II
31	Ground

See Introduction (i) for additional circuit diagram symbols.

### DIAGNOSIS

- If the diagram is accompanied by text:
  - Read the Circuit Operation before proceeding with the electrical diagnosis.
  - Read the Troubleshooting Hints before performing the System Diagnosis.
  - Tests follow the System Diagnosis.
  - When performing the System Diagnosis, be certain that all components disconnected in previous steps are reconnected unless otherwise directed.



Component is disconnected.  
Backprobe harness connector



Component is connected.  
Backprobe harness connector



Component is disconnected.  
Probe component



Component is disconnected.  
Probe harness connector



Probe in-line connector



Wire Colour Chart

B- Black	P- Purple
G- Green	R- Red
K- Pink	S- Grey
L- Light	U- Blue
N- Brown	W- White
O- Orange	Y- Yellow

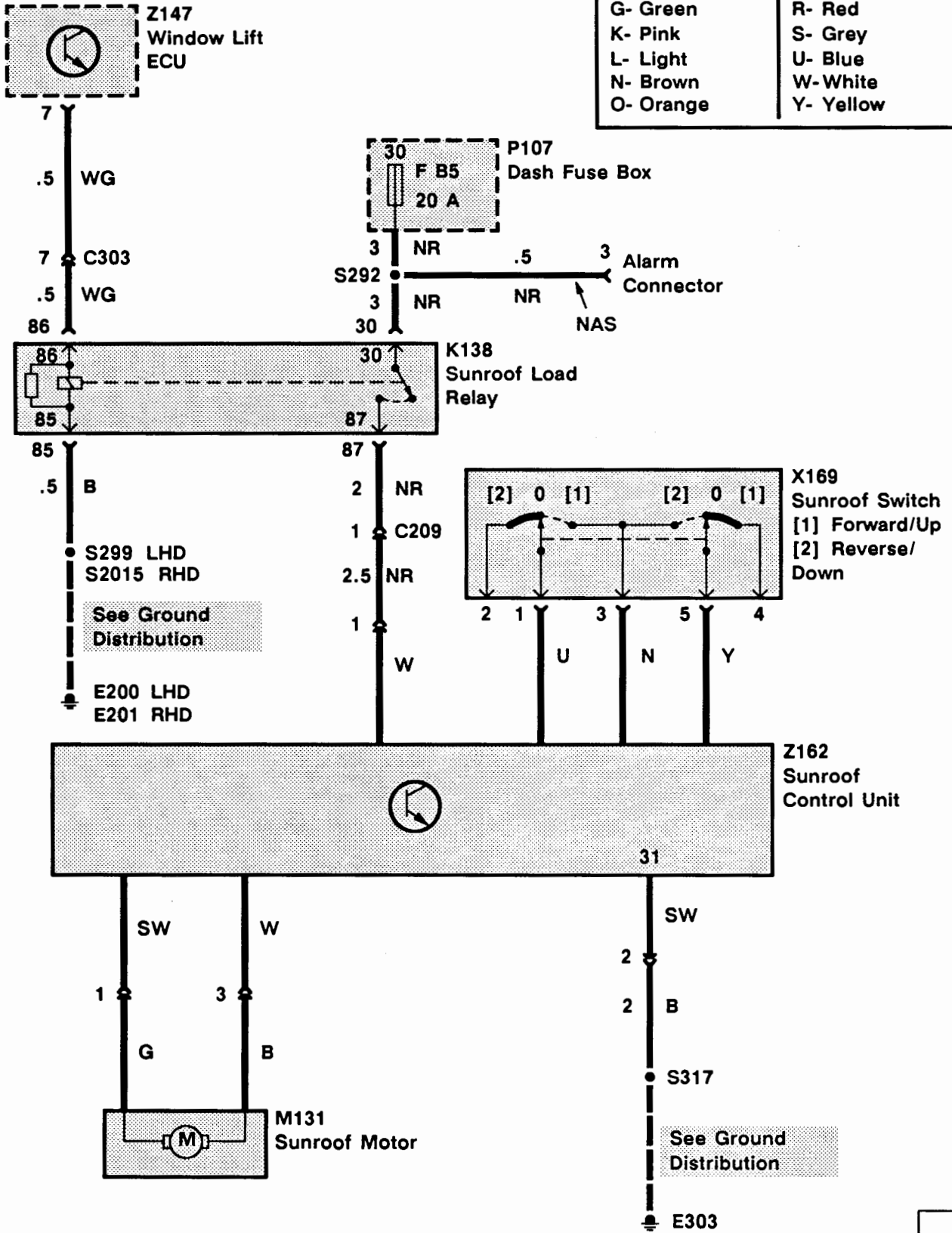

# 1993 RANGE ROVER

## KEY INFORMATION

### CIRCUIT DIAGRAMS

- Circuit diagrams are arranged so that current flow is from the top of the diagram (current source) to the bottom of the diagram (ground).
- Only those components that work together in the circuit are shown. If only part of a component is used in the circuit, then only that part of the component is shown.

● Remember:

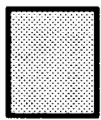

Entire component

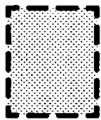

Part of a component

### TERMINAL NUMBER

### DESIGNATION

50	Battery voltage: Ignition Switch in position III
30	Battery voltage: supplied constantly
15	Battery voltage: Ignition Switch in position II or III
R	Battery voltage: Ignition Switch in positions I, II
31	Ground

See Introduction (i) for additional circuit diagram symbols.

### DIAGNOSIS

- If the diagram is accompanied by text:
  - Read the Circuit Operation before proceeding with the electrical diagnosis.
  - Read the Troubleshooting Hints before performing the System Diagnosis.
  - Tests follow the System Diagnosis.
  - When performing the System Diagnosis, be certain that all components disconnected in previous steps are reconnected unless otherwise directed.



Component is disconnected.  
Backprobe harness connector



Component is connected.  
Backprobe harness connector



Component is disconnected.  
Probe component



Component is disconnected.  
Probe harness connector



Probe in-line connector

## CIRCUIT OPERATION

The locking functions on 4 door models (without theft alarm or NAS models) is controlled by the Central Locking Control Unit (Z113). On non-NAS models equipped with the theft alarm system, the Theft Alarm Unit (Z163) controls the locking functions. On 2 door models without theft alarm, the Driver Door Lock Switch (X117) controls the passenger door and tailgate locking functions.



### 2 Door Operation (Without Theft Alarm)

Power to the Driver Door Lock Switch (X117) for the locking functions is supplied by fuse F C7 through the NK wire. The switch is grounded at E200 or E201 through the B wire.

When the driver's door is locked, the Driver Door Lock Switch applies voltage from terminal 2 to terminal 1 of the Passenger Door Lock Actuator (M118) and to terminal 2 of the Tailgate Lock Actuator (M132). At the same time the Driver Door Lock Switch also applies ground to the lock actuators momentarily when the driver's door is locked. The lock actuators' path to ground is through terminal 1 of the Driver Door Lock Switch. The switch grounds the actuators at E200 or E201 through its contacts. When the lock actuators are momentarily grounded, the actuators move to the locked position.

When the driver's door lock is unlocked, the Driver Door Lock Switch reverses the voltage applied to the actuators. The Driver Door Lock Switch now applies ground through its terminal 2 to the lock actuators. Voltage to unlock the actuators is supplied momentarily by the Driver Door Lock Switch at terminal 1 through the O and K wires.



### 4 Door and 2 Door With Theft Alarm Operation

Fuses F C7 and F E2 supply voltage to the Central Locking Control Unit (Z113) or the Theft Alarm Unit (Z163) for the locking functions. The control unit is grounded at terminal 11 to ground E200 or E201.

## Inputs

The Central Locking Control Unit (Z113) or the Theft Alarm Unit (Z163) monitors the position of the front door locks through input switches that are part of the Front Door Lock Actuators (M114, M122). When the control unit sees an input switch change position, the control unit responds by locking or unlocking the doors.

## Lock

The Central Locking Control Unit (Z113) or the Theft Alarm Unit (Z163) locks the doors by momentarily applying battery voltage to the actuators through the K wire. The lock actuators are grounded by the Central Locking Control Unit or the Theft Alarm Unit through the O wire. The actuators now move to the locked position.

## Unlock

To unlock the doors the Central Locking Control Unit (Z113) or the Theft Alarm Unit (Z163) momentarily applies battery voltage to the actuators through the O wire. The actuators are grounded by the Central Locking Control Unit or the Theft Alarm Unit through the K wire. The lock actuators now unlock.

## Fuel Flap

When the Fuel Flap Release Switch (X125) is operated, voltage from fuse F C6 is applied to the Fuel Flap Actuator (M108) through the switch, the YK wire and the YP wire. The actuator is grounded to the Fuel Filler Pipe (P110) and ground E402.



Wire Colour Chart

B- Black	P- Purple
G- Green	R- Red
K- Pink	S- Grey
L- Light	U- Blue
N- Brown	W- White
O- Orange	Y- Yellow

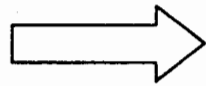
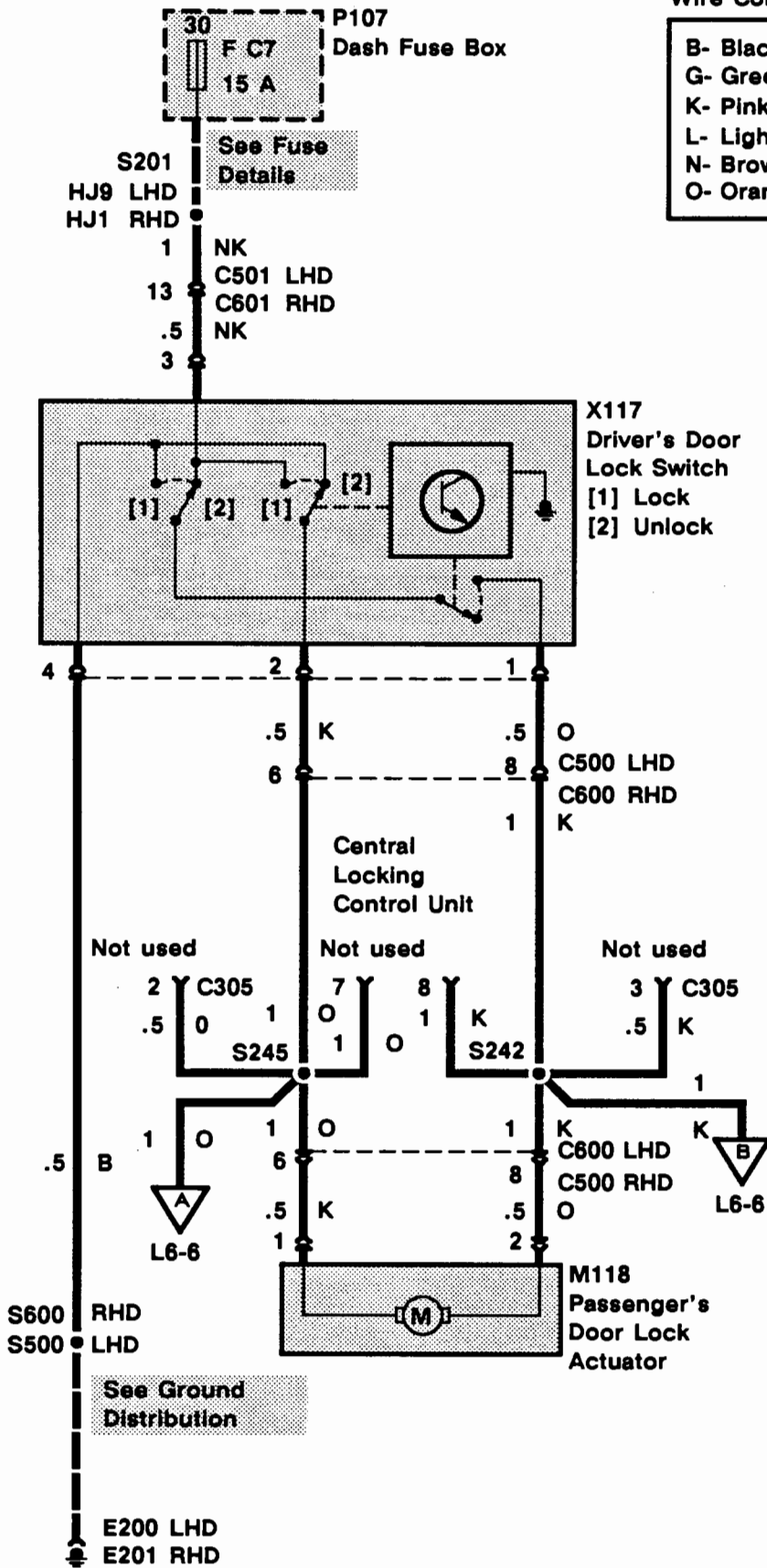

REV: AUG 93

# L6 ETM

## 1993/1994 RANGE ROVER

### Wire Colour Chart

B- Black	P- Purple
G- Green	R- Red
K- Pink	S- Grey
L- Light	U- Blue
N- Brown	W- White
O- Orange	Y- Yellow

+ 2-Door  
++ 4-Door

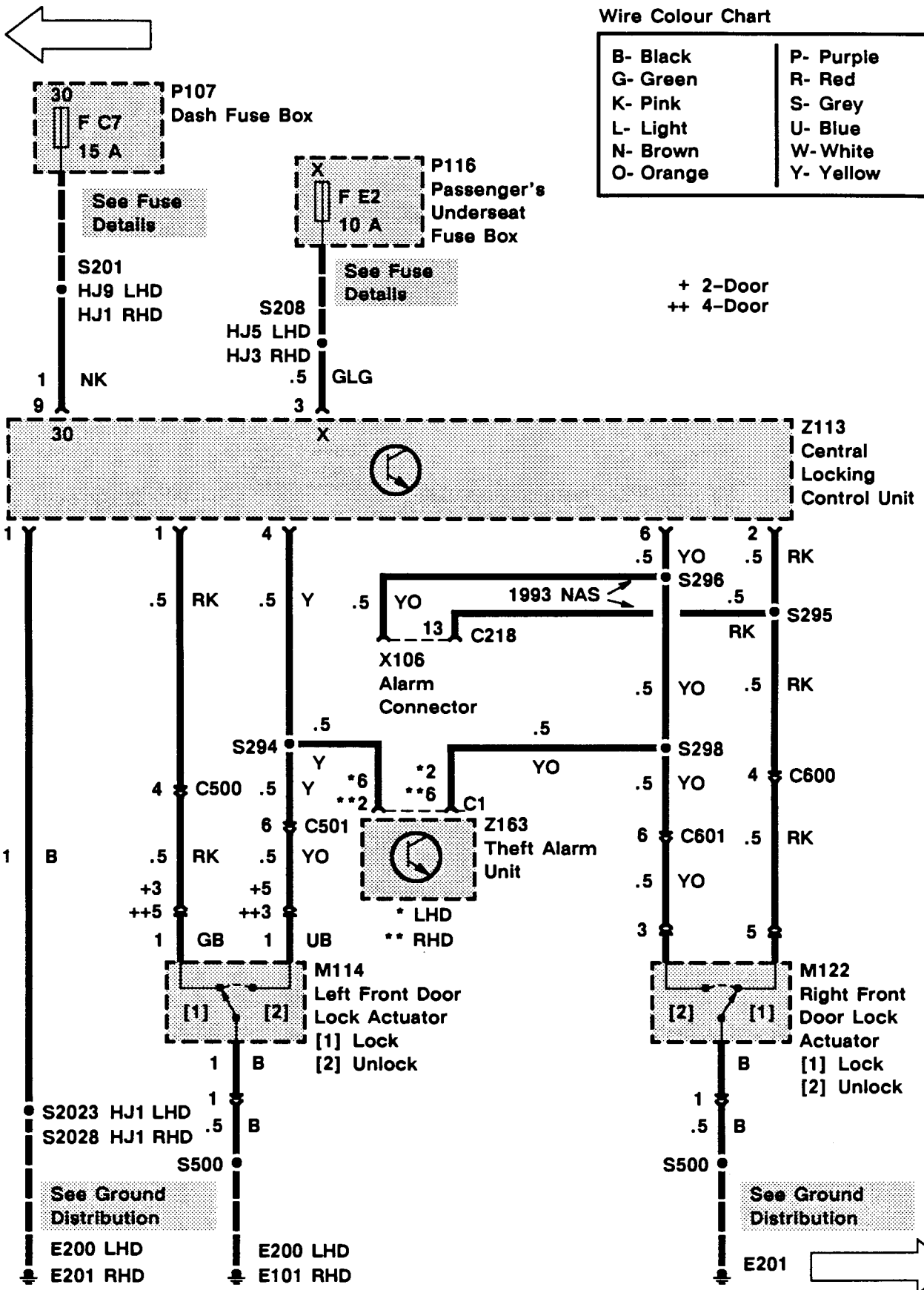

REV: AUG 93

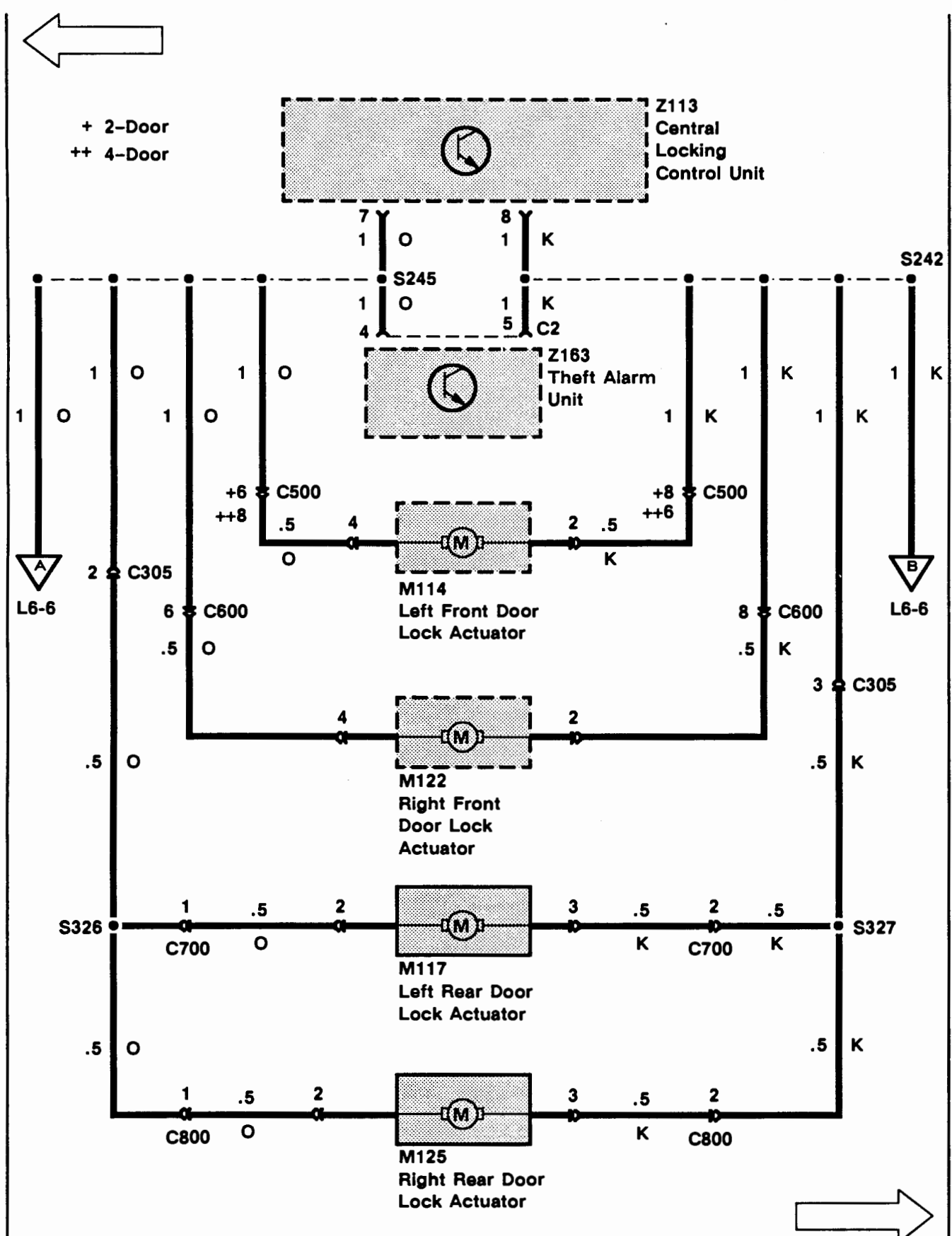

REV: AUG 93

# L6 ETM

## 1993 RANGE ROVER

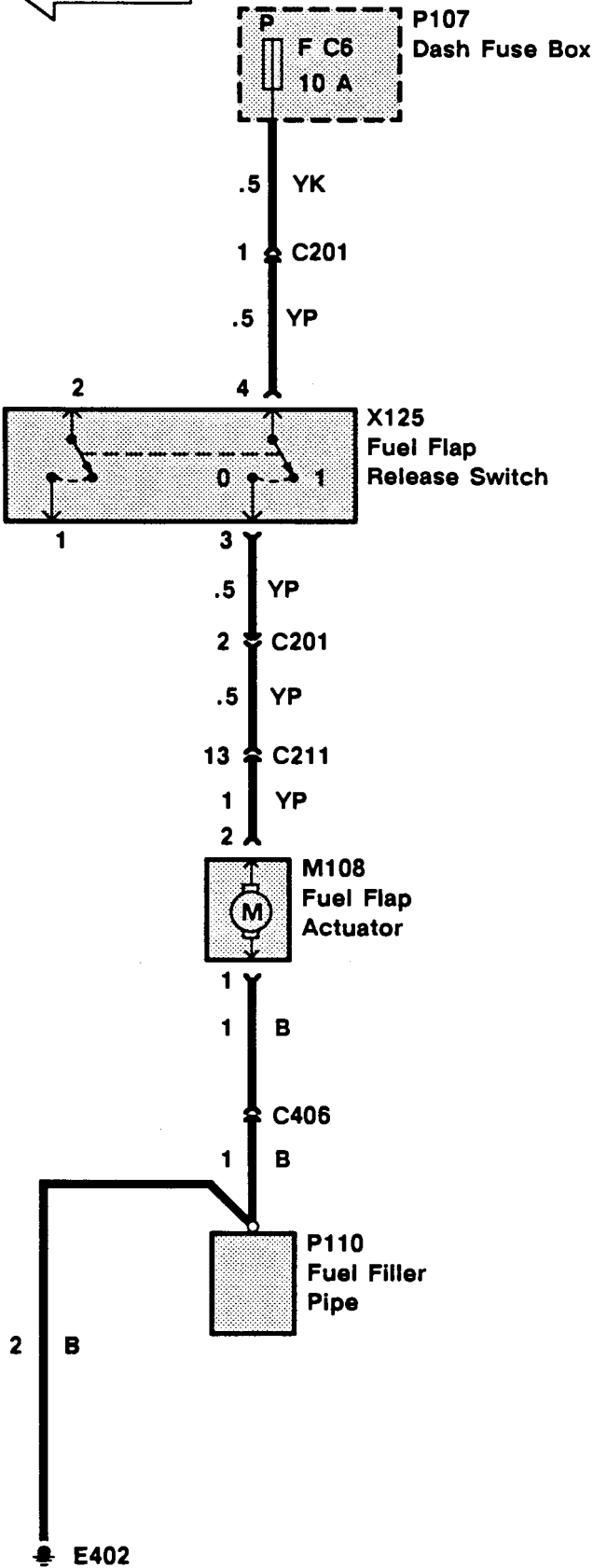
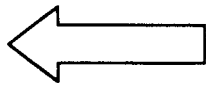

Wire Colour Chart

B- Black	P- Purple
G- Green	R- Red
K- Pink	S- Grey
L- Light	U- Blue
N- Brown	W- White
O- Orange	Y- Yellow

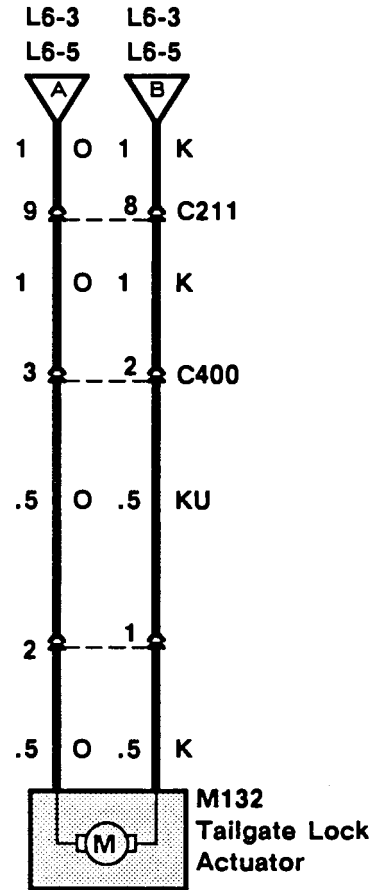



**SYSTEM DIAGNOSIS****2 Door (Without Theft Alarm)**

1. If the Passenger Door Lock Actuator (M118) and Tailgate Lock Actuator (M132) do not lock or unlock, do Test H, the Driver Door Lock Switch (X117) test.
2. If the Passenger Door Lock Actuator (M118) does not operate but the Tailgate Lock Actuator (M132) works, do Test I.
3. If the Tailgate Lock Actuator (M132) does not work, do Test E.

**4 Door (Without Theft Alarm)**

1. If no central locking functions work, do Test A, power and ground test
2. If a Front Door Lock Actuator (M114, M122) does not operate, do Test B.
3. If the doors relock or unlock themselves after operating the door locks, do Test C, door input short test.
4. If the central locking function does not operate from one of the front doors, do Test D, open door input test.
5. If both Rear Door Lock Actuators (M117, M125) do not operate, do Test F.
6. If the Tailgate Lock Actuator (M132) does not work, do Test E.

**Fuel Flap**

If the fuel flap does not release when operated, do Test G.

**2 Door or 4 Door (With Theft Alarm)**

1. If no central locking functions work, do Test J.
2. If a Front Door Lock Actuator (M114, M122) does not operate, do Test B.
3. If the doors unlock themselves after operating the door locks, do Test K, door input short test.
4. If the central locking function does not operate from one of the front doors, do Test L.
5. If both Rear Door Lock Actuators (M117, M125) do not operate, do Test F.
6. If the Tailgate Lock Actuator (M132) does not work, do Test E.

# L6 ETM

## 1993 RANGE ROVER

### Test A

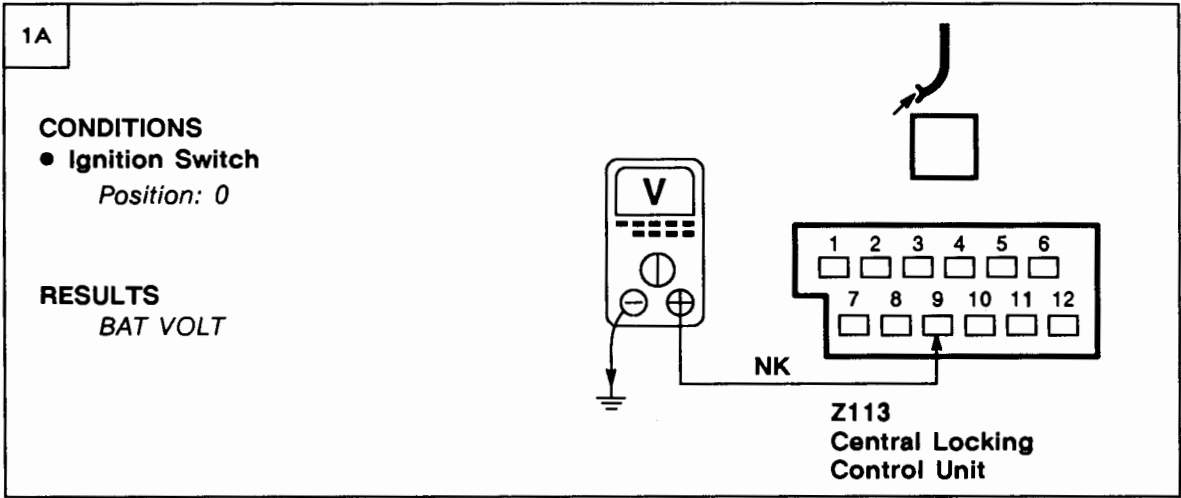

**PROBLEM CAUSE**

- F C7 Fuse
- NK Wire

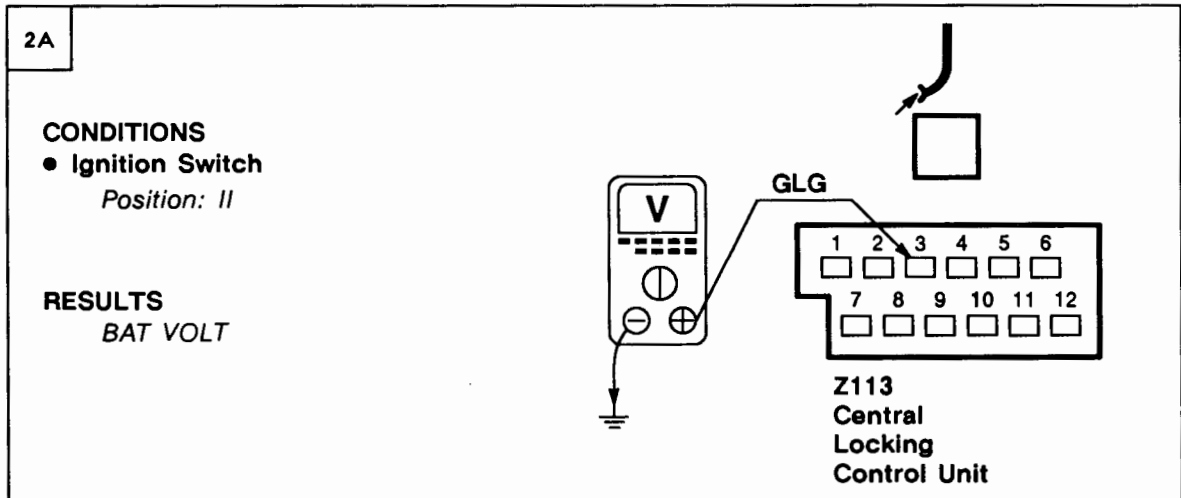

**PROBLEM CAUSE**

- F E2 Fuse
- GLG Wire



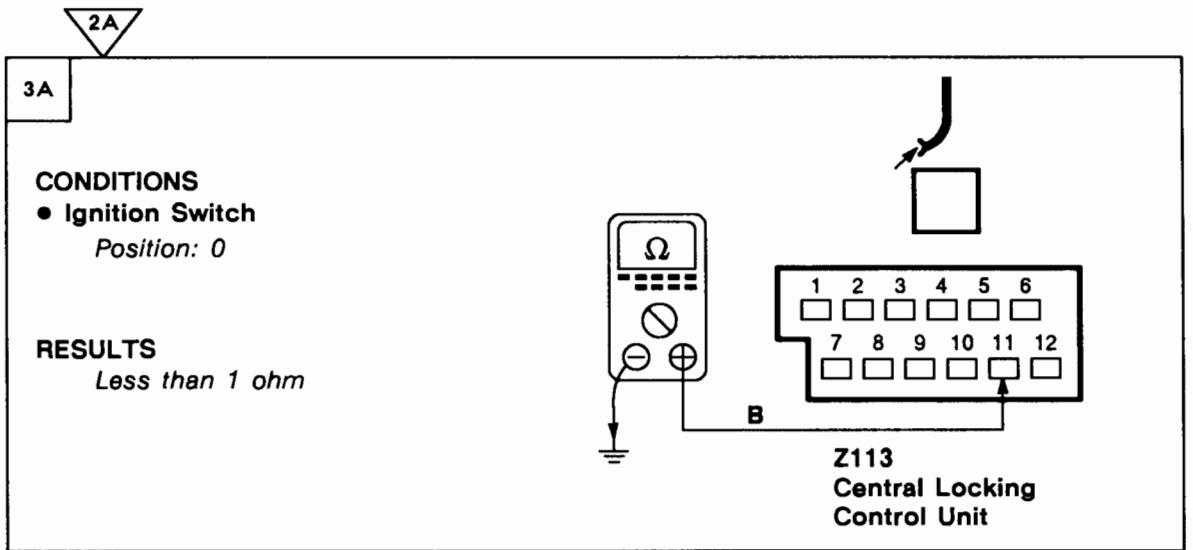

~~OK~~ PROBLEM CAUSE

- B Wire
- E200 LHD
- E201 RHD

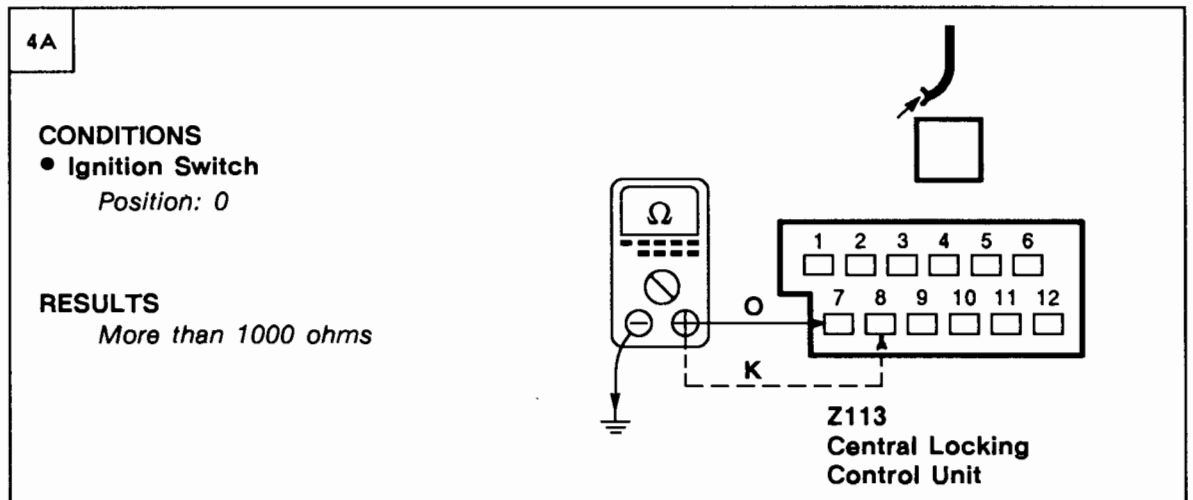
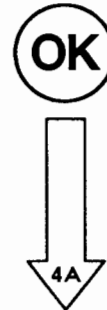

~~OK~~ PROBLEM CAUSE

- O Wire
- K Wire

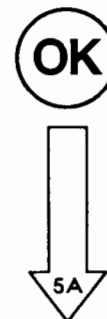

# L6 ETM

## 1993 RANGE ROVER

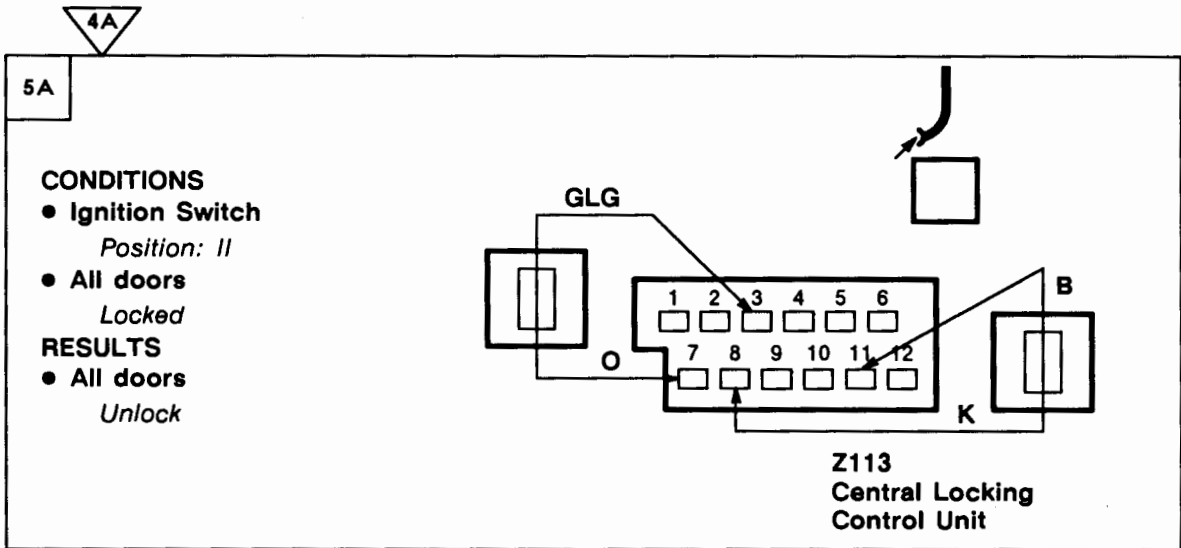

GO TO TEST B



**PROBLEM CAUSE**  
- Central Locking  
Control Unit

### Test B

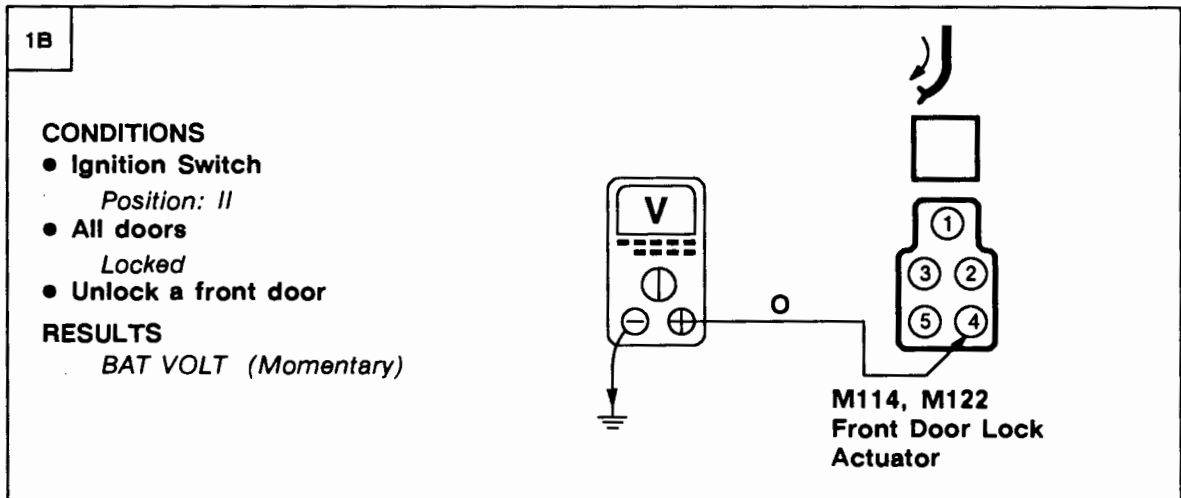

**PROBLEM CAUSE**  
- O Wire



1B

2B

**CONDITIONS**

- Ignition Switch  
*Position: II*
- All doors  
*Unlocked*
- Lock a front door

**RESULTS**  
*BAT VOLT (Momentary)*

M114, M122  
Front Door Lock  
Actuator

**OK** PROBLEM CAUSE  
- K Wire

**OK** PROBLEM CAUSE  
- M114, M122 Front Door  
Lock Actuator

**Test C**

1C

1C

**CONDITIONS**

- Ignition Switch  
*Position: 0*
- All doors  
*Unlocked*

**RESULTS**  
*More than 1000 ohms*

Z113  
Central  
Locking  
Control Unit

**OK** PROBLEM CAUSE  
- RK Wire  
- M114, M122 Front Door  
Lock Actuator

**OK**  
↓  
2C

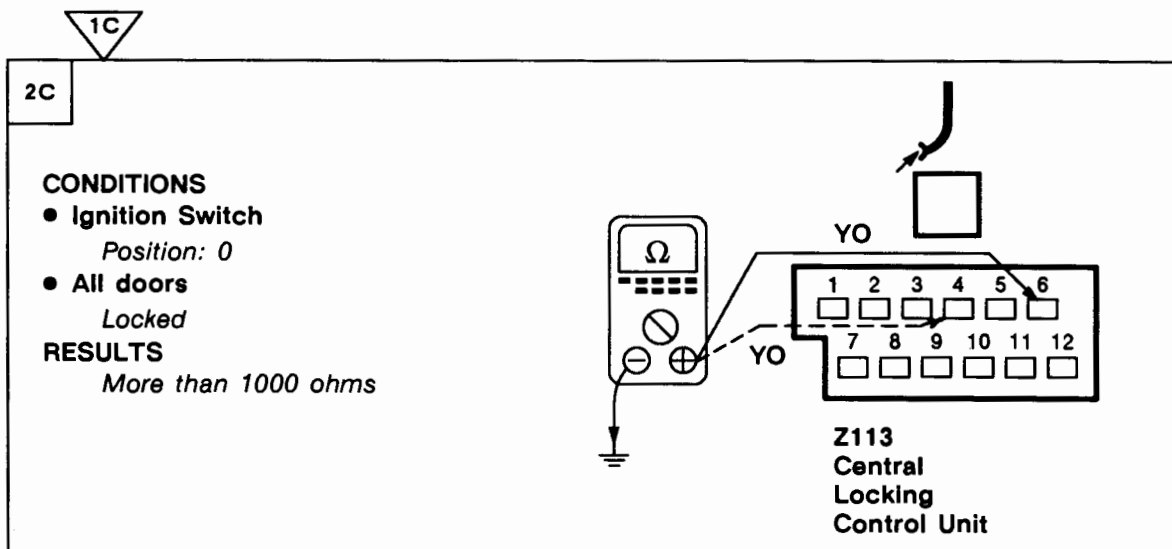

**PROBLEM CAUSE**

- YO Wire
- M114, M122 Front Door Lock Actuator
- Theft Alarm Unit



**PROBLEM CAUSE**

- Central Locking Control Unit

**Test D**

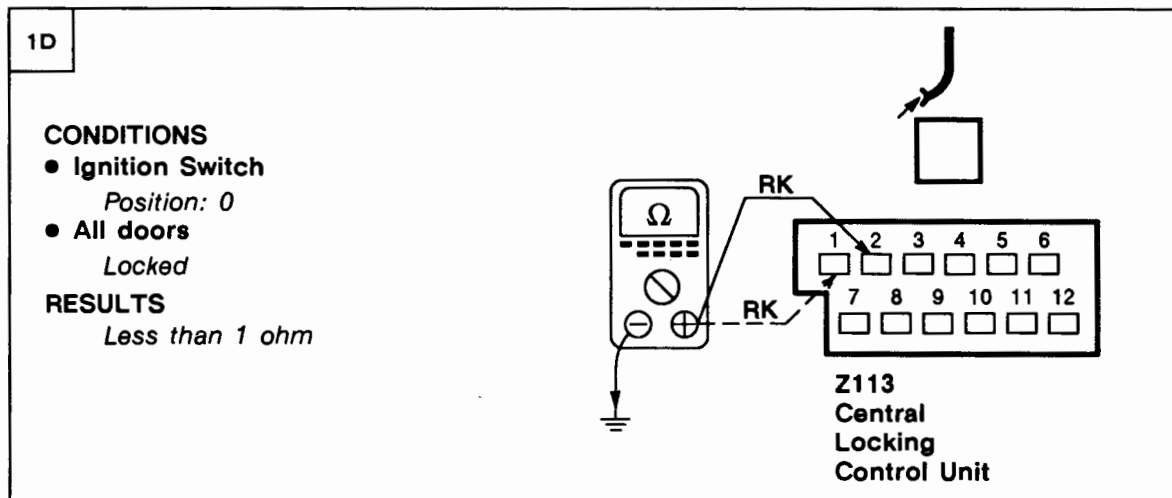

GO TO TEST 3D



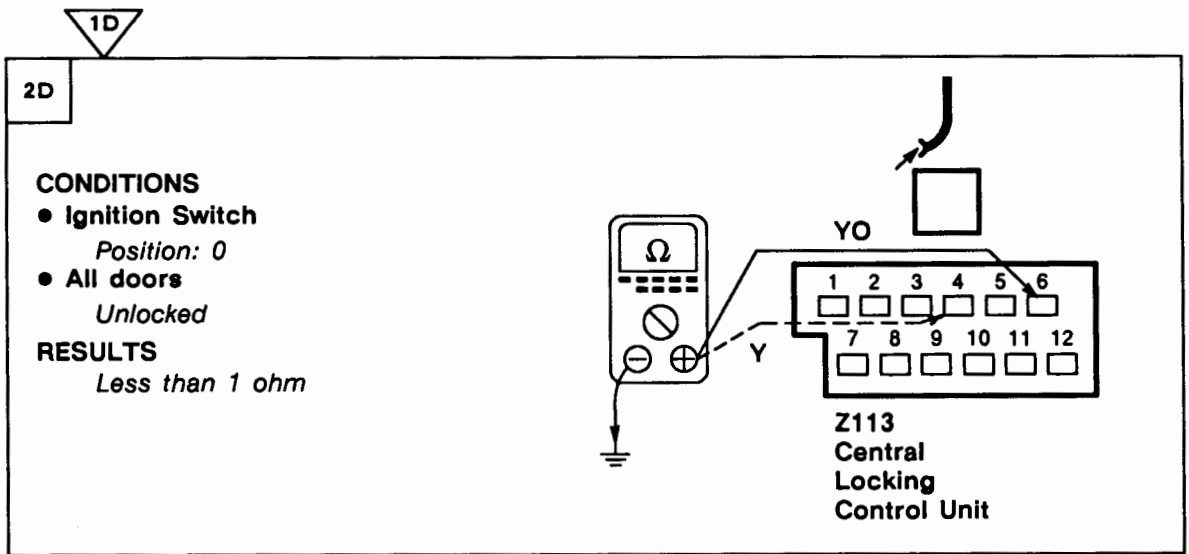

**PROBLEM CAUSE**  
- Central Locking Control Unit

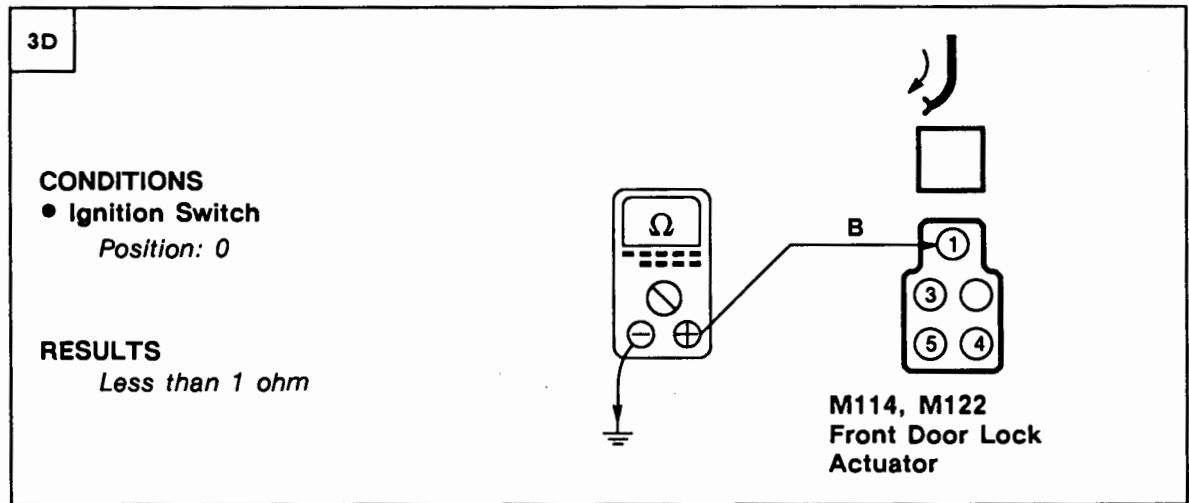

**PROBLEM CAUSE**

- B Wire
- E200 LHD
- E201 RHD
- E101 RHD

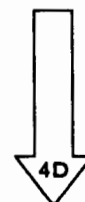

3D

4D

**CONDITIONS**

- Ignition Switch  
*Position: II*
- All doors  
*Unlocked*

**RESULTS**

- All doors  
*Lock*

M114, M122  
Front Door Lock  
Actuator



**PROBLEM CAUSE**

- RK Wire
- Central Locking Control Unit



5D

**CONDITIONS**

- Ignition Switch  
*Position: 0*
- All doors  
*Locked*

**RESULTS**

- All doors  
*Unlock*

M114, M122  
Front Door Lock  
Actuator



**PROBLEM CAUSE**

- YO Wire
- Central Locking Control Unit



**PROBLEM CAUSE**

- M114, M122 Front Door Lock Actuator



**Test E**

1E

**CONDITIONS**

- Ignition Switch  
*Position: 0*
- All doors  
*Unlocked*
- Lock a front door

**RESULTS**  
*BAT VOLT (Momentary)*

**M132  
Tailgate Lock  
Actuator**



**PROBLEM CAUSE**

- K Wire
- KO Wire
- Rear Screen Noise Suppressor



2E

**CONDITIONS**

- Ignition Switch  
*Position: 0*
- All doors  
*Locked*
- Unlock a front door

**RESULTS**  
*BAT VOLT (Momentary)*

**M132  
Tailgate Lock  
Actuator**



**PROBLEM CAUSE**

- O Wire



**PROBLEM CAUSE**

- Tailgate Lock Actuator

Test F

1F

**CONDITIONS**

- Ignition Switch  
*Position: 0*
- All doors  
*Unlocked*
- Lock a front door

**RESULTS**  
*BAT VOLT (Momentary)*

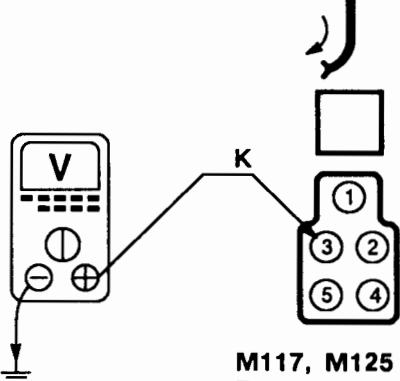

**M117, M125  
Rear  
Door Lock  
Actuator**



**PROBLEM CAUSE**  
- K Wire

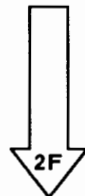

2F

**CONDITIONS**

- Ignition Switch  
*Position: 0*
- All doors  
*Locked*
- Unlock a front door

**RESULTS**  
*BAT VOLT (Momentary)*

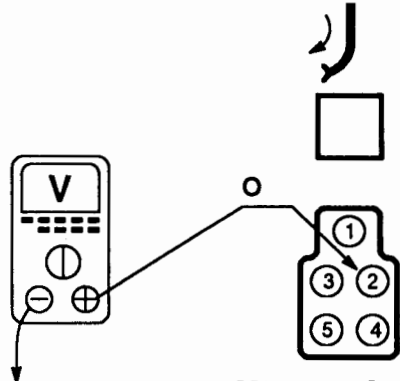

**M117, M125  
Rear Door Lock  
Actuator**



**PROBLEM CAUSE**  
- O Wire



**PROBLEM CAUSE**  
- M117, M125 Rear Door  
Lock Actuator

Test G

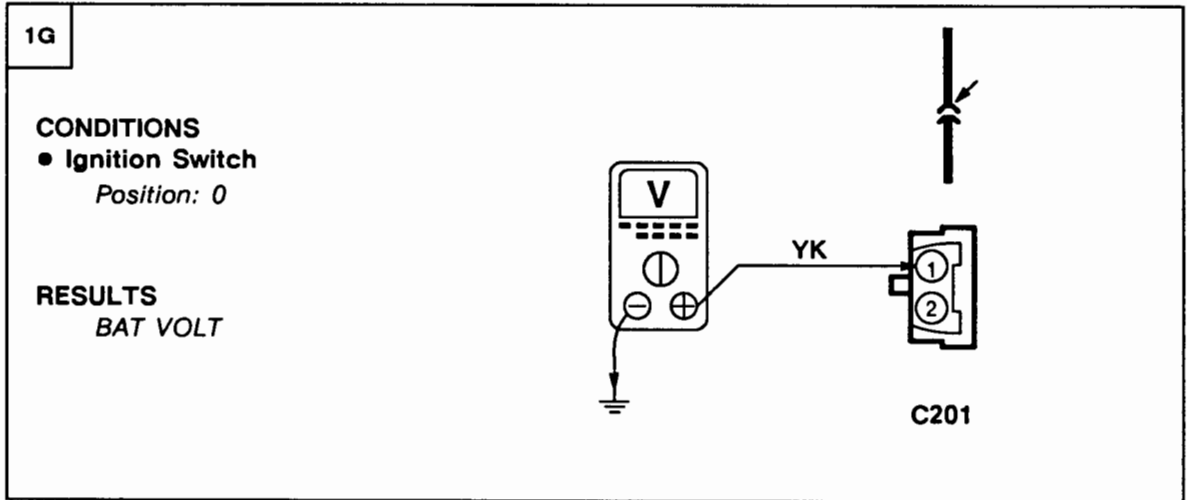

~~OK~~ PROBLEM CAUSE

- F C6 Fuse
- YK Wire

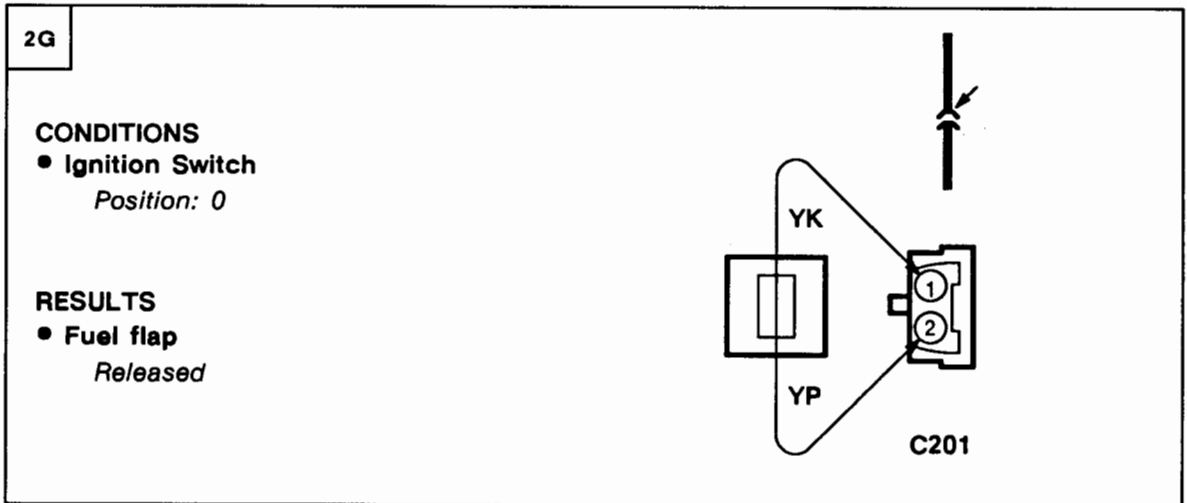
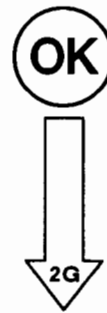

OK PROBLEM CAUSE

- Fuel Flap Release Switch

**L6 ETM**

1993 RANGE ROVER

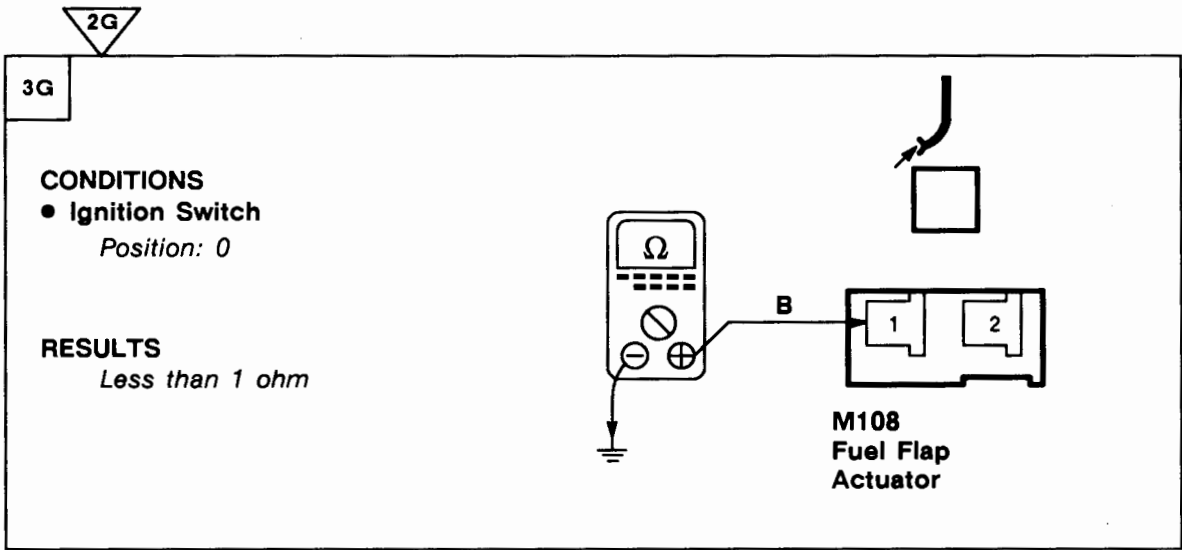

~~OK~~ **PROBLEM CAUSE**

- B Wire
- E402

OK

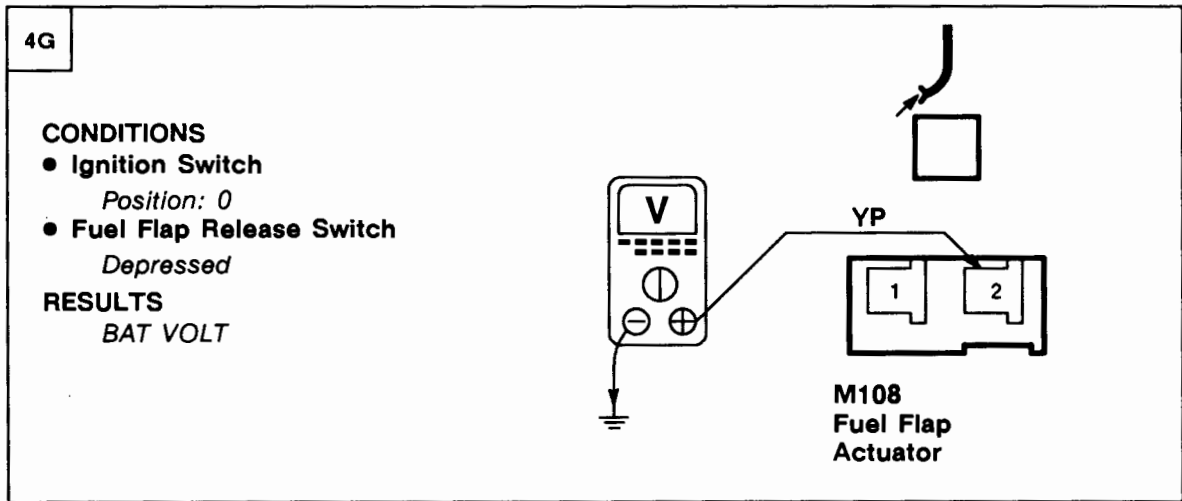
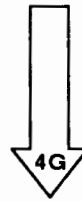

~~OK~~ **PROBLEM CAUSE**

- YP Wire

OK **PROBLEM CAUSE**

- Fuel Flap Actuator

**Test H**

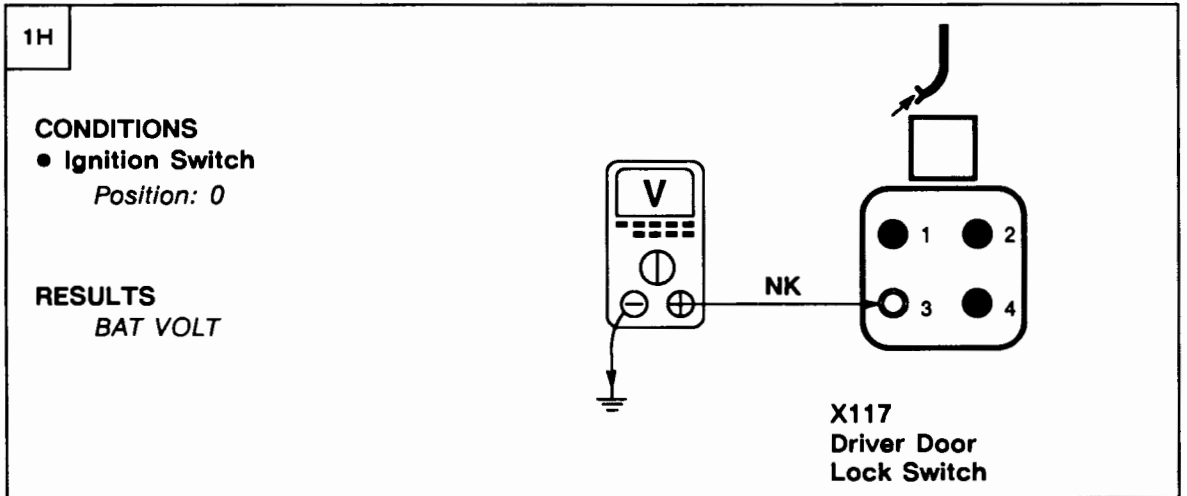

~~OK~~ **PROBLEM CAUSE**  
- F C7 Fuse  
- NK Wire

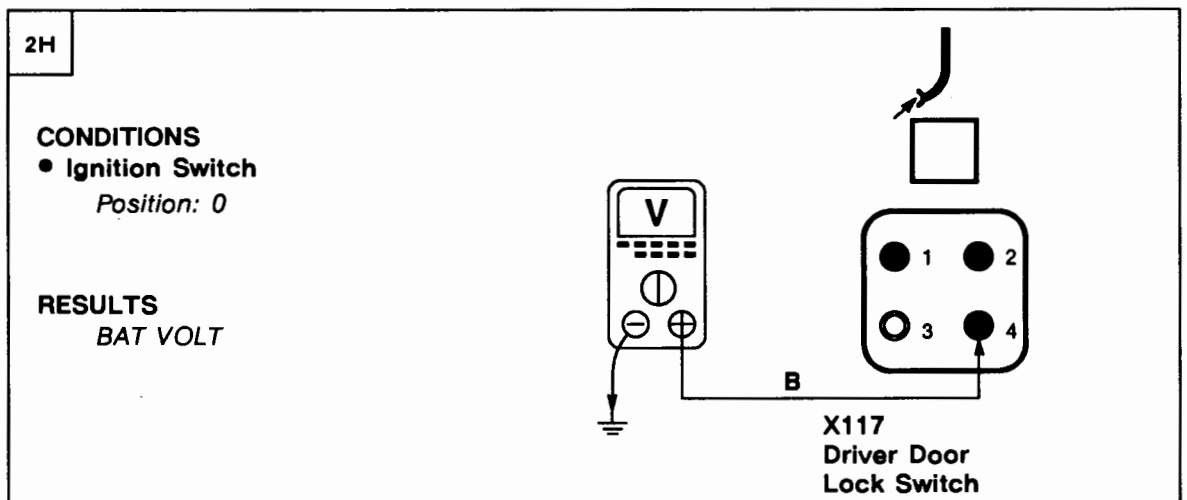
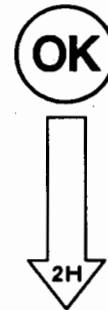

~~OK~~ **PROBLEM CAUSE**  
- B Wire  
- E200

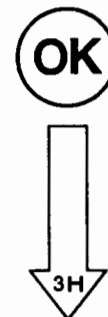

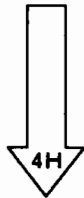
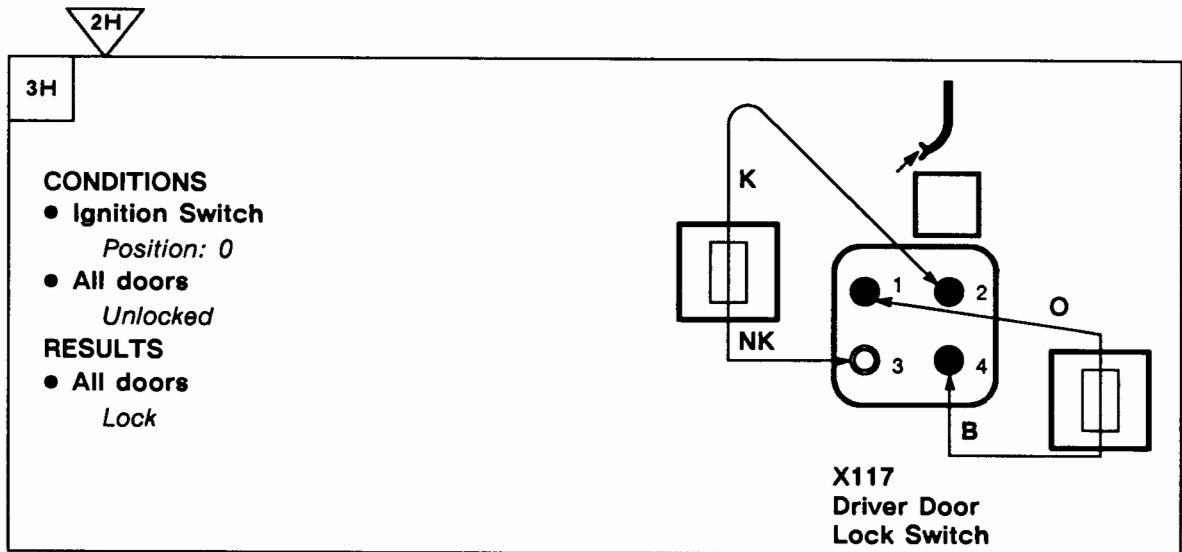

**PROBLEM CAUSE**  
- Driver Door Lock Switch

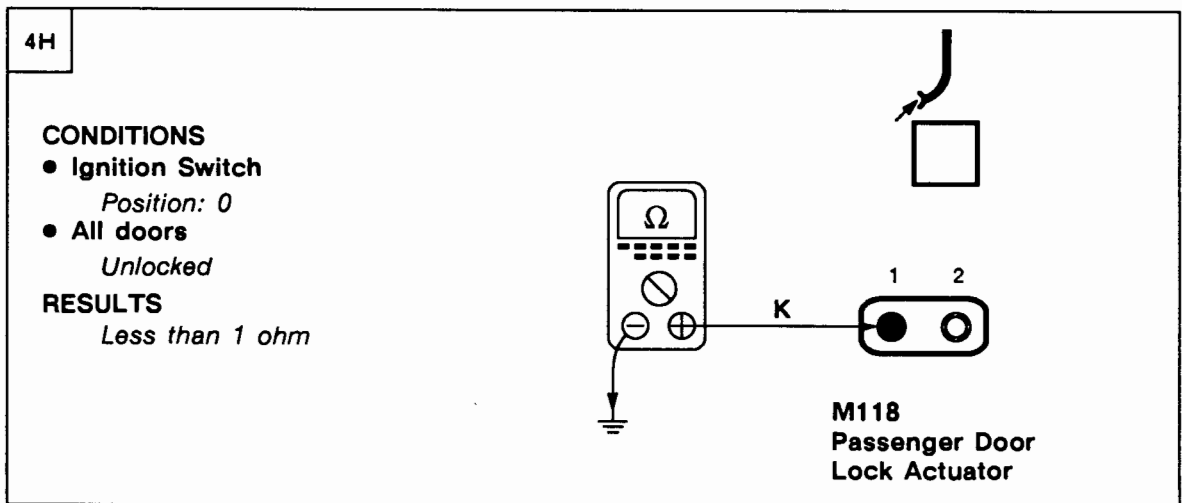

**PROBLEM CAUSE**  
- K Wire



**PROBLEM CAUSE**  
- K Wire

Test I

11

**CONDITIONS**

- Ignition Switch  
*Position: 0*
- All doors  
*Unlocked*
- Lock driver's door

**RESULTS**  
BAT VOLT (Momentary)

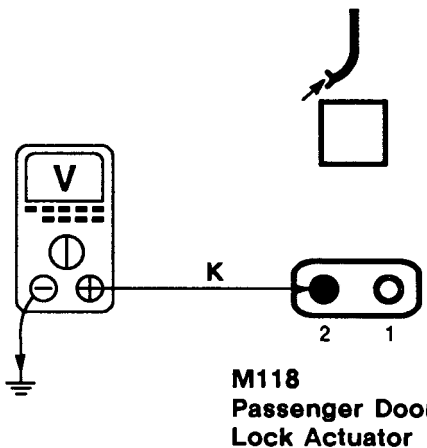

M118  
Passenger Door  
Lock Actuator

~~OK~~ PROBLEM CAUSE  
- K Wire

OK

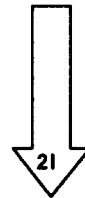

21

**CONDITIONS**

- Ignition Switch  
*Position: 0*
- All doors  
*Locked*
- Unlock driver's door

**RESULTS**  
BAT VOLT (Momentary)

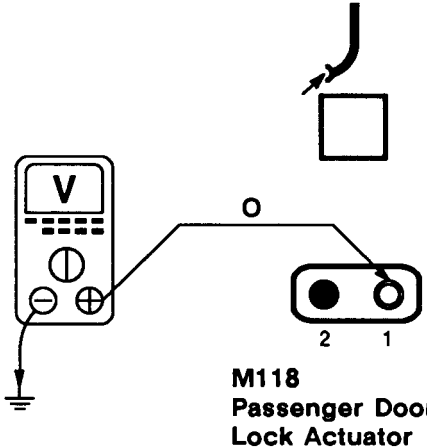

M118  
Passenger Door  
Lock Actuator

~~OK~~ PROBLEM CAUSE  
- O Wire

OK

PROBLEM CAUSE  
- Passenger Door Lock  
Actuator

Test J

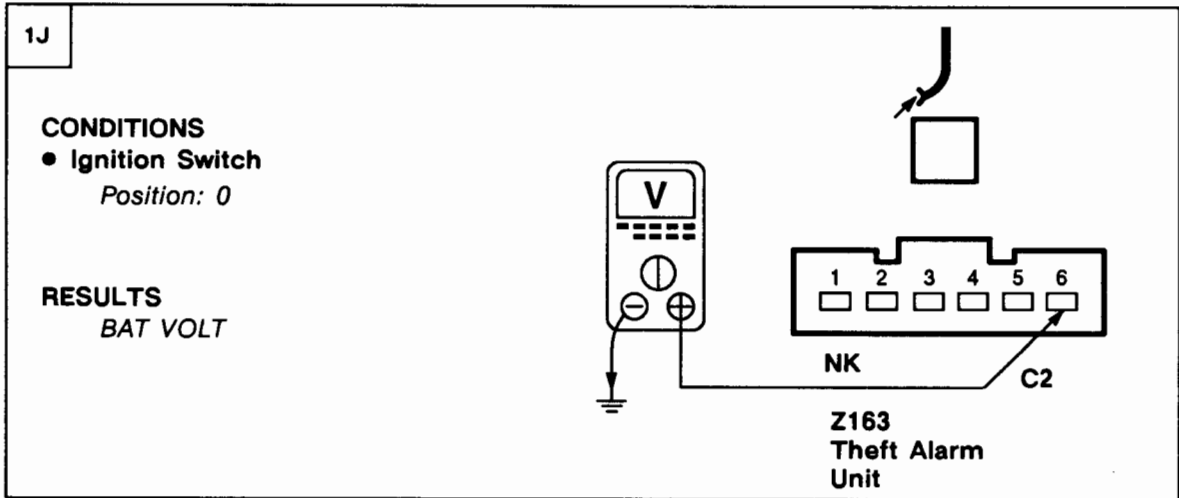

**PROBLEM CAUSE**

- F C7 Fuse
- NK Wire

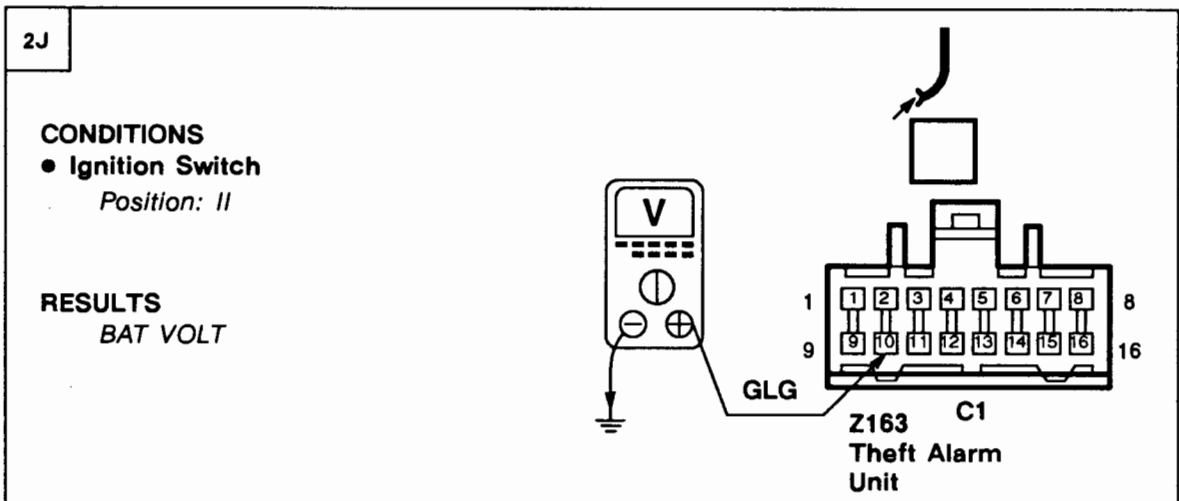
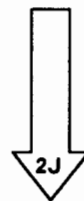

**PROBLEM CAUSE**

- F E2 Fuse
- GLG Wire

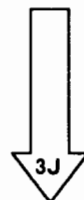



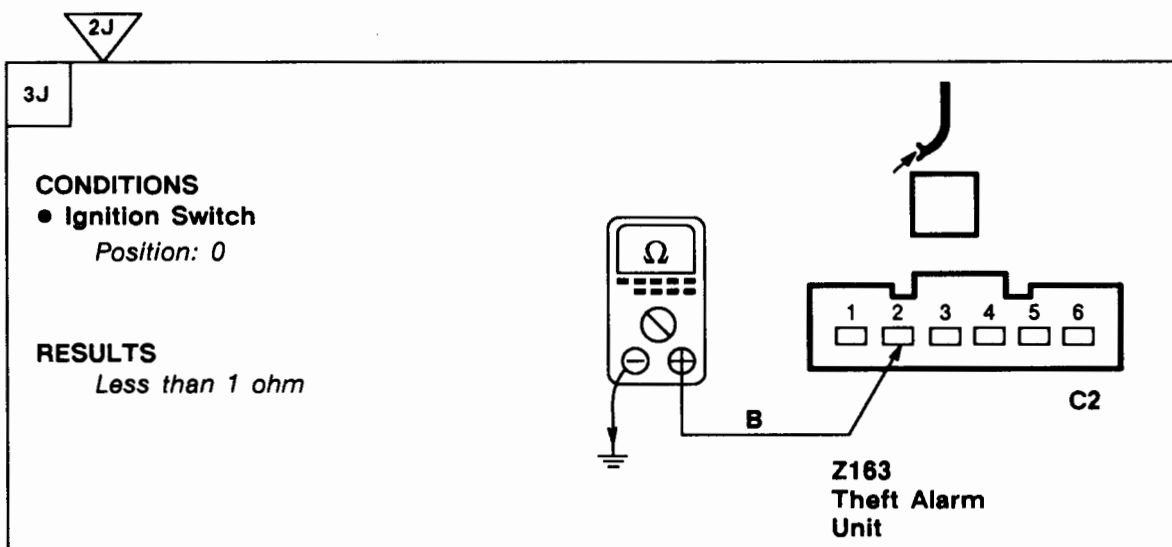

~~OK~~ **PROBLEM CAUSE**

- B Wire
- E200 LHD
- E201 RHD

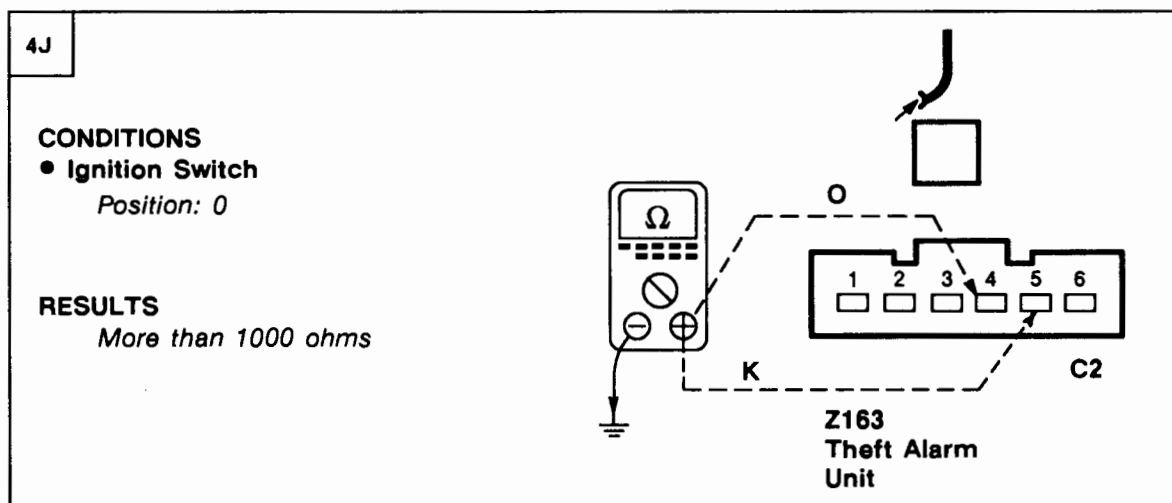
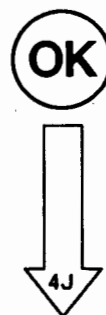

~~OK~~ **PROBLEM CAUSE**

- O Wire
- K Wire

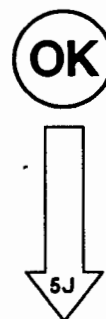

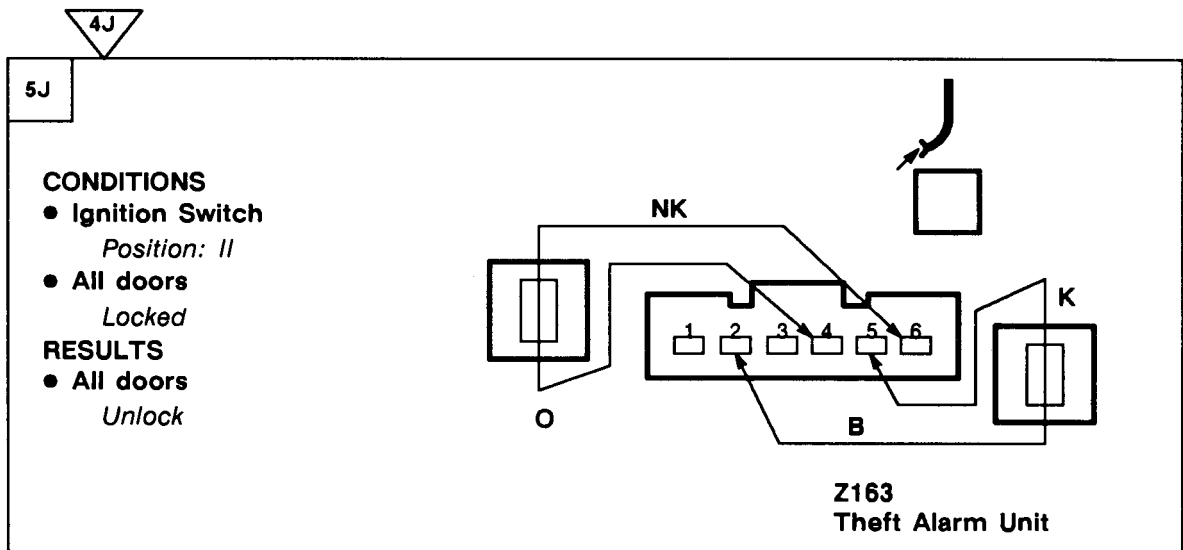

GO TO TEST B



PROBLEM CAUSE  
- Theft Alarm Unit

**Test K**

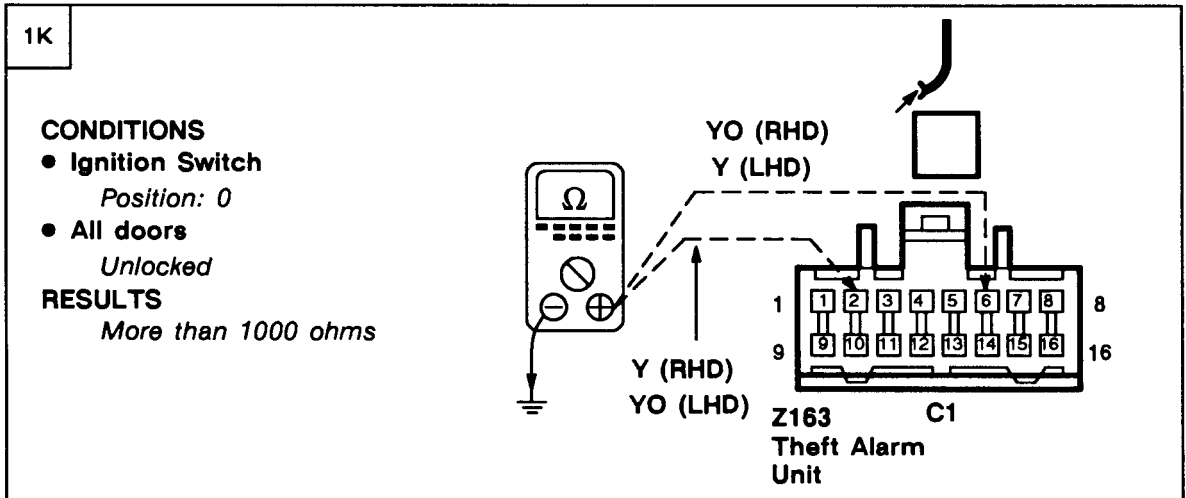

**PROBLEM CAUSE**

- Y Wire
- YO Wire
- M114, M122 Front Door Lock Actuator



**PROBLEM CAUSE**

- Theft Alarm Unit

# L6 ETM

## 1993 RANGE ROVER

### Test L

1L

**CONDITIONS**

- Ignition Switch  
*Position: 0*
- All doors  
*Unlocked*

**RESULTS**  
*Less than 1 ohm*

YO (RHD)  
Y (LHD)

Y (RHD)  
YO (LHD)

Z163  
Theft Alarm Unit

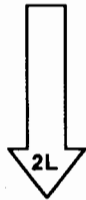

**PROBLEM CAUSE**  
- Theft Alarm Unit

2L

**CONDITIONS**

- Ignition Switch  
*Position: 0*

**RESULTS**  
*Less than 1 ohm*

B

M114, M122  
Front Door Lock  
Actuator



**PROBLEM CAUSE**

- B Wire
- E200 LHD
- E201 RHD
- E101 RHD

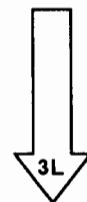

2L

3L

M114, M122  
Front Door Lock  
Actuator

**CONDITIONS**

- Ignition Switch  
*Position: II*
- All doors  
*Unlocked*

**RESULTS**

- All doors  
*Lock*

**OK** PROBLEM CAUSE

- RK Wire
- Theft Alarm Unit



4L

M114, M122  
Front Door Lock  
Actuator

**CONDITIONS**

- Ignition Switch  
*Position: 0*
- All doors  
*Locked*

**RESULTS**

- All doors  
*Unlock*

**OK** PROBLEM CAUSE

- YO Wire
- Theft Alarm Unit

**OK** PROBLEM CAUSE

- M114, M122 Front Door Lock Actuator

# 1993 RANGE ROVER

## KEY INFORMATION

### CIRCUIT DIAGRAMS

- Circuit diagrams are arranged so that current flow is from the top of the diagram (current source) to the bottom of the diagram (ground).
- Only those components that work together in the circuit are shown. If only part of a component is used in the circuit, then only that part of the component is shown.

### ● Remember:

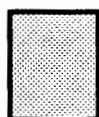

Entire component

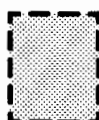

Part of a component

### TERMINAL NUMBER

### DESIGNATION

50	Battery voltage: Ignition Switch in position III
30	Battery voltage: supplied constantly
15	Battery voltage: Ignition Switch in position II or III
R	Battery voltage: Ignition Switch in positions I, II
31	Ground

See Introduction (i) for additional circuit diagram symbols.

### DIAGNOSIS

- If the diagram is accompanied by text:
  - Read the Circuit Operation before proceeding with the electrical diagnosis.
  - Read the Troubleshooting Hints before performing the System Diagnosis.
  - Tests follow the System Diagnosis.
  - When performing the System Diagnosis, be certain that all components disconnected in previous steps are reconnected unless otherwise directed.



Component is disconnected.  
Backprobe harness connector



Component is connected.  
Backprobe harness connector



Component is disconnected.  
Probe component



Component is disconnected.  
Probe harness connector



Probe in-line connector



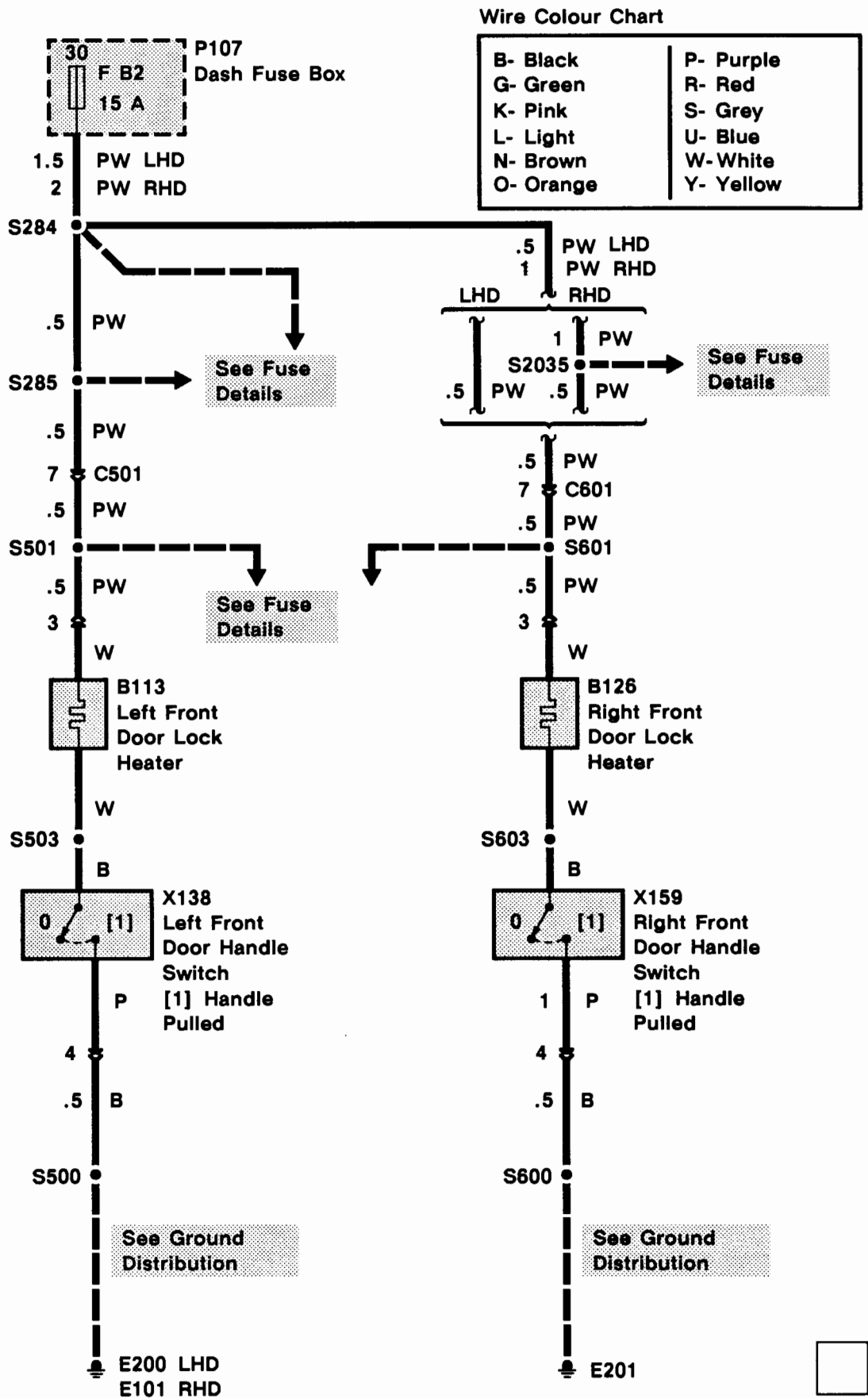

# 1993 RANGE ROVER

## KEY INFORMATION

### CIRCUIT DIAGRAMS

- Circuit diagrams are arranged so that current flow is from the top of the diagram (current source) to the bottom of the diagram (ground).
- Only those components that work together in the circuit are shown. If only part of a component is used in the circuit, then only that part of the component is shown.

#### ● Remember:

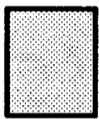

Entire component

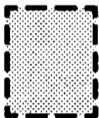

Part of a component

### TERMINAL NUMBER

### DESIGNATION

50	Battery voltage: Ignition Switch in position III
30	Battery voltage: supplied constantly
15	Battery voltage: Ignition Switch in position II or III
R	Battery voltage: Ignition Switch in positions I, II
31	Ground

See Introduction (i) for additional circuit diagram symbols.

### DIAGNOSIS

- If the diagram is accompanied by text:
  - Read the Circuit Operation before proceeding with the electrical diagnosis.
  - Read the Troubleshooting Hints before performing the System Diagnosis.
  - Tests follow the System Diagnosis.
  - When performing the System Diagnosis, be certain that all components disconnected in previous steps are reconnected unless otherwise directed.



Component is disconnected.  
Backprobe harness connector



Component is connected.  
Backprobe harness connector



Component is disconnected.  
Probe component



Component is disconnected.  
Probe harness connector



Probe in-line connector

