

COOLANT

Drain and refill

Draining

WARNING: Do not remove the expansion tank filler cap when the engine is hot because the cooling system is pressurised and personal scalding could result.

1. Remove the expansion tank filler cap by first turning it anti-clockwise a quarter of a turn to allow pressure to escape, then turn it further in the same direction and lift off.

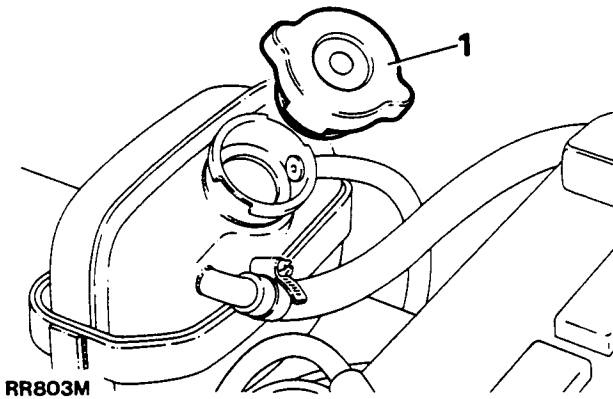

2. Remove the radiator filler plug and washer to assist drainage.

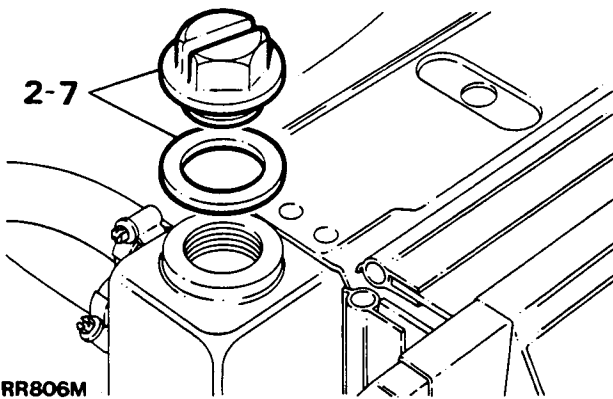

3. Disconnect the radiator bottom hose and allow the coolant to drain into a suitable container. Use a clean container if the coolant solution is to be reused. Re-connect the bottom hose after draining and tighten the hose clip.

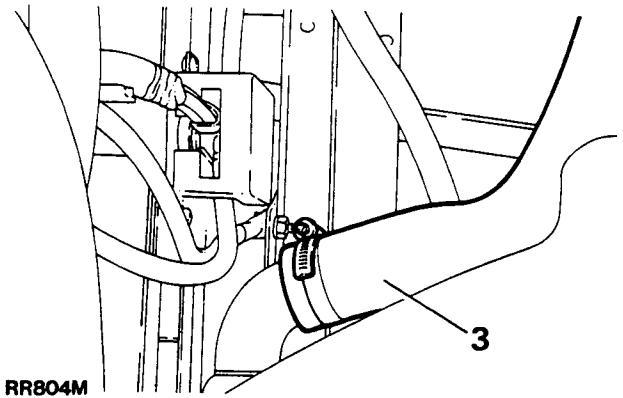

4. Remove the engine drain plugs, one each side of the cylinder block, beneath the exhaust manifolds. Allow the coolant to drain and refit plugs.

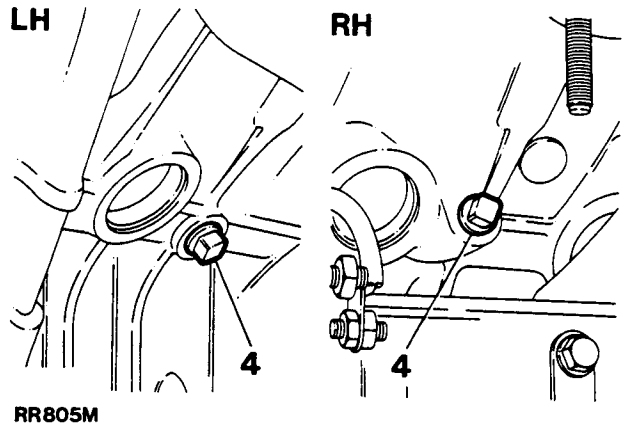

See the following coolant requirements before refilling the system.

continued

Coolant requirements

Frost precautions and engine protection

The engine cooling system **MUST ALWAYS** be filled and topped-up with a solution of water and anti-freeze, winter and summer, or, where frost precautions are not required, water and inhibitor. **NEVER** use water alone as this may corrode the aluminium alloy.

CAUTION: Do not use salt water even with an inhibitor, otherwise corrosion will occur. In certain territories where the only available natural water supply has some salt content use only rain or distilled water.

Recommended solutions

Anti-freeze: Universal Anti-freeze or permanent type ethylene base, without methanol, with a suitable inhibitor for aluminium engines and engine parts.

Use one part of anti-freeze to one part of water.

Inhibitor: Marston Lubricants SQ36 inhibitor concentrate.

If frost precautions are not required use a 10% solution of inhibitor, i.e. one part inhibitor to nine parts of water. Inhibitor solution should be drained and flushed out and new inhibitor solution introduced every two years, or sooner where the purity of the water is questionable.

Anti-freeze can remain in the cooling system and will provide adequate protection for two years provided that the specific gravity of the coolant is checked before the onset of the second winter and topped-up with new anti-freeze as required.

Vehicles leaving the factory have the cooling system filled with 50% of anti-freeze mixture. This gives protection against frost down to minus 47°C (minus 53°F). Vehicles so filled can be identified by a label affixed to the windscreen and radiator.

After the second winter the system should be drained and thoroughly flushed. Before adding new anti-freeze examine all joints and renew defective hoses to make sure that the system is leakproof.

See the 'Recommended Lubricants, Fluids and Capacities' section for protection quantities.

Refilling

5. Pour 4.5 litre (1 gal) of water into the radiator.
6. Add the recommended quantity of anti-freeze or inhibitor.
7. Top-up the radiator with water, refit the radiator filler plug and washer and tighten.
8. Add water to the expansion tank, up to the 'WATER LEVEL' plate.

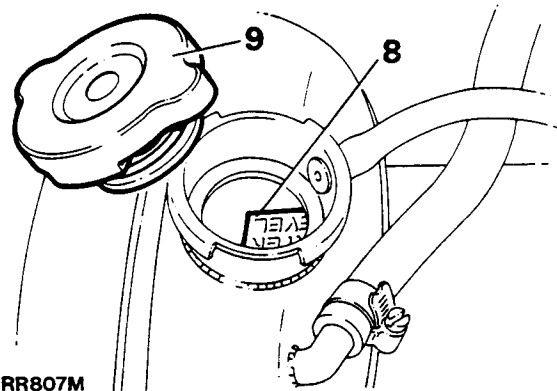

RR807M

9. Fit the expansion tank filler cap.
10. Run the engine until normal operating temperature is attained, that is, thermostat open.
11. Allow the engine to cool, then check the coolant level and top-up if necessary.

EXPANSION TANK

Remove and refit

Removing

WARNING: Do not remove the expansion tank filler cap when the engine is hot because the cooling system is pressurised and personal scalding could result.

1. Remove the expansion tank filler cap by first turning it anti-clockwise a quarter of a turn to allow pressure to escape, then turn it further in the same direction and lift off.

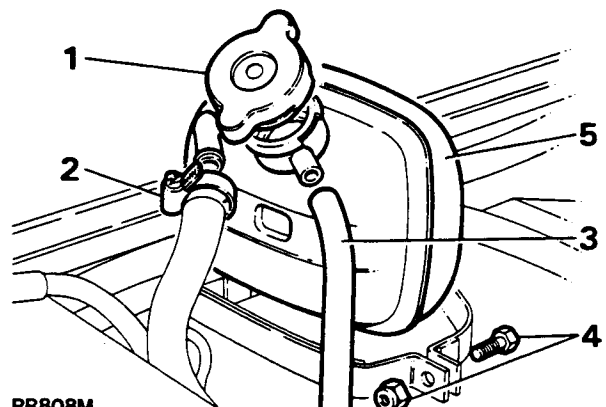

RR808M

2. Disconnect the hose to the radiator.
3. Disconnect the overflow pipe.
4. Remove the pinch bolt.
5. Lift out the expansion tank.

Refitting

6. Reverse 2 to 5.
7. Replenish the cooling system.

FAN BELT

Check and adjust tension, 1 and 5 to 6

Remove and refit, 1 to 6

Removing

1. Slacken the jockey pulley pivot bolt.
2. Pivot the jockey pulley inwards.
3. Lift off the fan belt.

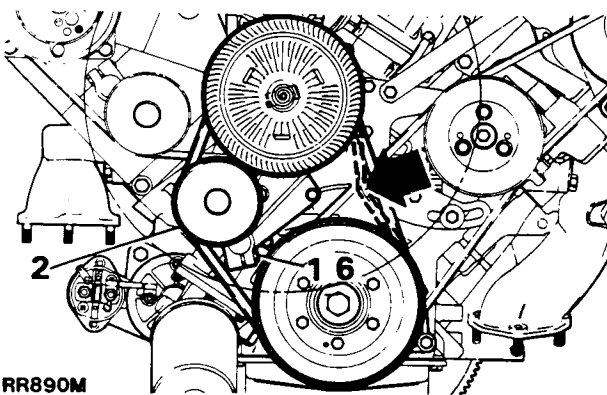

RR890M

Refitting

4. Locate the fan belt on the pulleys.
5. Adjust the fan belt using the jockey pulley to give 11 to 14 mm (0.437 to 0.572 in) free movement when checked midway between the fan and crankshaft pulleys by hand.
6. Tighten the jockey pulley pivot bolt and check the adjustment.

NOTE: Re-check belt adjustment after approximately 1500 km (1,000 miles) running when a new belt has been fitted.

VISCOUS COUPLING, FAN BLADES, PULLEY AND FAN COWL

Viscous coupling—remove and refit 1 to 5

Fan blades—remove and refit 1 to 5 and 8

Fan cowl—remove and refit 1 to 4

Fan pulley—remove and refit 1 to 7

Removing

1. Slacken the nut securing the viscous coupling and fan blade assembly to the water pump spindle.
2. Remove the four fan cowl fixings and lift the cowl out of its lower mountings.

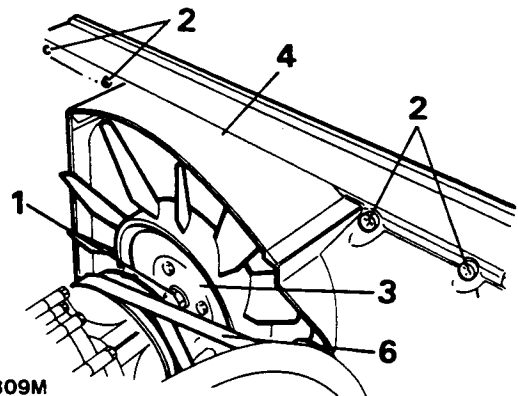

RR809M

3. Remove the viscous coupling securing nut and withdraw the assembly.
4. Remove the fan cowl, if required.

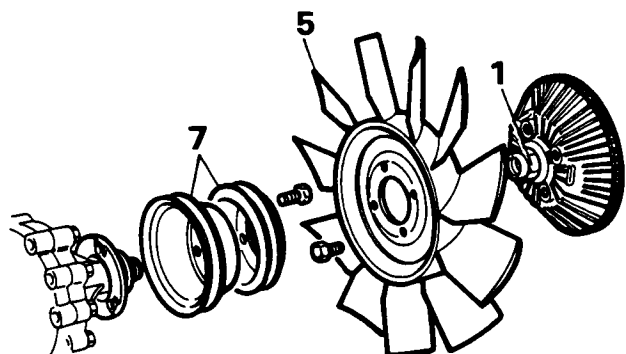

RR810M

5. Remove the fan blades from the viscous coupling, if required.
6. Remove the fan belt and, if fitted, the compressor belt.
7. Remove the pulley fixings and withdraw the pulley.

Continued

8. Vehicles having seven-bladed fans have a detachable boss securing the viscous coupling. Follow 1 to 5 above and remove the bolt to dismantle.

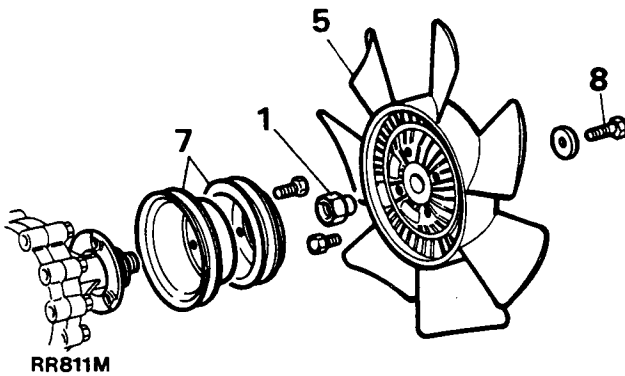

Refitting

- Reverse the above procedure, ensuring the fan blades are fitted correctly. Eleven-bladed fans are marked FRONT. Seven-bladed fans are fitted with the deeper dished side towards the viscous coupling. See 'Data' section for correct torque figures.
- Adjust the fan belt and compressor belt.

RADIATOR

Remove and refit

Removing

- Drain the cooling system.
- Remove the fan blades.
- Remove the fan cowl.
- Disconnect the top hose from the radiator.

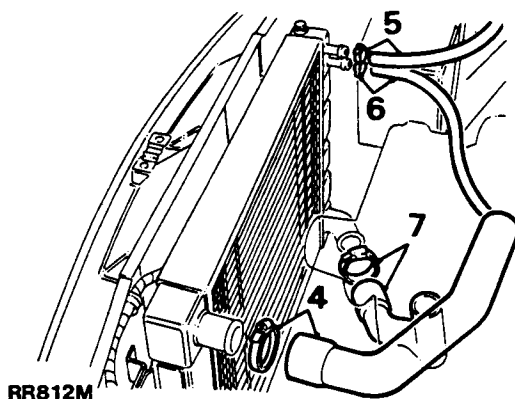

- Disconnect the hose to the expansion tank.
- Disconnect the hose to the induction manifold.
- Disconnect the hose from the bottom of the radiator.
- Remove the fixings from each side of the radiator.

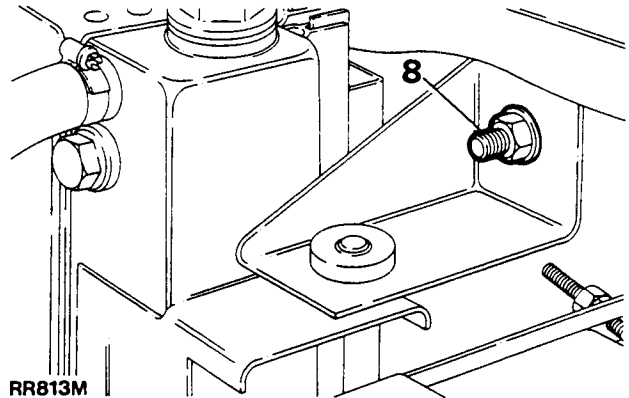

- Withdraw the radiator from the rubber-mounted spigots.

Refitting

- Reverse 1 to 9 noting the assembly order of the radiator side fixings and ensuring that the radiator sealing strips are correctly located and secure.

THERMOSTAT

Remove and refit

Test

Removing

- Drain the cooling system, sufficient to drain the induction manifold.
- Disconnect the hose to the radiator.

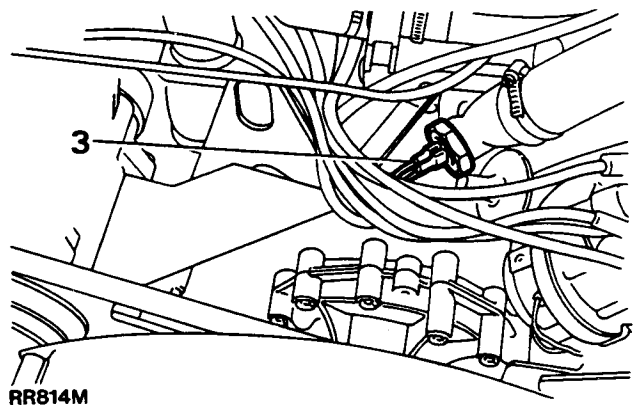

- Disconnect the electrical connections to the water temperature switch, if fitted.

Continued

4. Remove the outlet elbow.
5. Withdraw the thermostat.

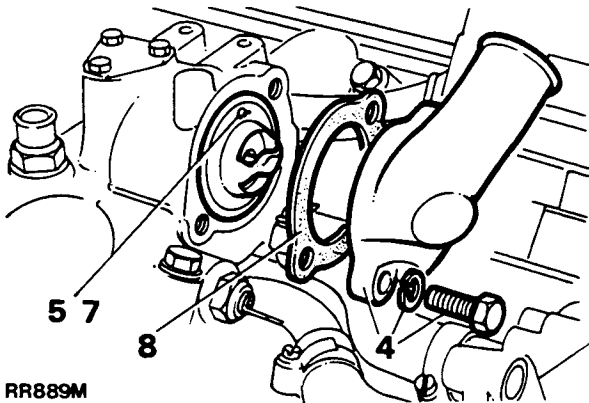

Testing

6. Note that the rating of the thermostat is 88°C. Place the thermostat in a suitable container half full of water. Heat the water and observe the temperature at which the thermostat opens.

Refitting

7. Insert the thermostat with the jiggle pin uppermost (12 o'clock).
8. Using a new joint washer, fit the outlet elbow and tighten to the correct torque, see 'Data' section.
9. Reverse 1 to 3.

WATER PUMP

Remove and refit

Removing

1. Drain the engine cooling system.
2. Remove the fan belt and, where fitted, the compressor belt.
3. Remove the fan blades and pulley.
4. Remove the air control valve from the support bracket (carburettor vehicles only).
5. Release the alternator adjusting link and the power-steering pump fixings.
6. Disconnect the inlet hose from the water pump.

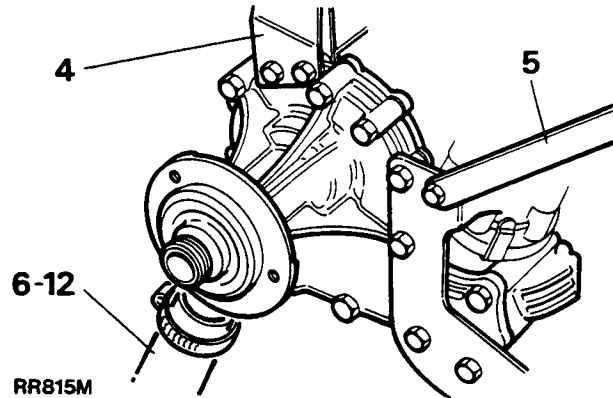

7. Remove the water pump.

Refitting

8. Lightly grease a new joint washer and place it in position on the timing cover.

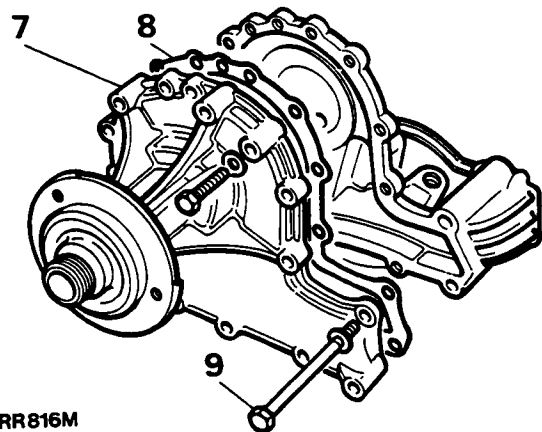

9. Clean the threads of the four long bolts and smear with Loctite 572 thread lubricant-sealant.
10. Locate the water pump in position.
11. Locate the alternator adjusting link and power-steering pump bracket.
12. Leave the alternator adjusting link loose and tighten the remaining water pump housing bolts evenly and to the correct torque, see 'Data' section.
13. Connect the inlet hose to the water pump.
14. Fit the fan pulley.
15. Fit the air-control valve to the support bracket.
16. Fit and adjust the fan belt, power-steering pump belt and, where applicable, the compressor belt.
17. Fit the fan blade assembly.
18. Refill the cooling system.

COOLING SYSTEM FAULT DIAGNOSIS

SYMPTOM	POSSIBLE CAUSE	CURE
A—EXTERNAL LEAKAGE	<ol style="list-style-type: none"> 1. Loose hose clips 2. Defective rubber hose 3. Damaged radiator seams 4. Excessive wear in the water pump 5. Loose core plugs 6. Damaged gaskets 7. Leaks at the heater connections or plugs 8. Leak at the water temperature gauge plug 	<ol style="list-style-type: none"> 1. Tighten 2. Renew 3. Rectify 4. Renew 5. Renew 6. Renew 7. Rectify 8. Tighten
B—INTERNAL LEAKAGE	<ol style="list-style-type: none"> 1. Defective cylinder head gasket 2. Cracked cylinder wall 3. Loose cylinder head bolts 	<ol style="list-style-type: none"> 1. Renew. Check engine oil for contamination and refill as necessary 2. Renew cylinder block 3. Tighten. Check engine for oil contamination and refill as necessary
C—WATER LOSS	<ol style="list-style-type: none"> 1. Boiling 2. Internal or external leakage 3. Restricted radiator or inoperative thermostat 	<ol style="list-style-type: none"> 1. Ascertain the cause of engine overheating and correct as necessary 2. See items A and B 3. Flush radiator or renew the thermostat as necessary
D—POOR CIRCULATION	<ol style="list-style-type: none"> 1. Restriction in system 2. Insufficient coolant 3. Inoperative water pump 4. Loose fan belt 5. Inoperative thermostat 	<ol style="list-style-type: none"> 1. Check hoses for crimps, reverse-flush the radiator, and clear the system of rust and sludge 2. Replenish 3. Renew 4. Adjust 5. Renew
E—CORROSION	<ol style="list-style-type: none"> 1. Excessive impurity in the water 2. Infrequent flushing and draining of system 3. Incorrect anti-freeze mixtures 	<ol style="list-style-type: none"> 1. Use only soft, clean water together with correct anti-freeze or inhibitor mixture 2. The cooling system should be drained and flushed thoroughly at least once a year 3. Certain anti-freeze solutions have a corrosive effect on parts of the cooling system. Only recommended solutions should be used
F—OVERHEATING	<ol style="list-style-type: none"> 1. Poor circulation 2. Dirty oil and sludge in engine 3. Radiator fins choked with chaff, mud, etc. 4. Incorrect ignition timing 5. Insufficient coolant 6. Low oil level 7. Tight engine 8. Choked or damaged exhaust pipe or silencer 9. Dragging brakes 10. Overloading vehicle 11. Driving in heavy sand or mud 12. Engine labouring on gradients 13. Low gear work 14. Excessive engine idling 15. Inaccurate temperature gauge 16. Defective thermostat 	<ol style="list-style-type: none"> 1. See item D 2. Refill 3. Use air pressure from the engine side of the radiator and clean out passages thoroughly 4. Check using electronic equipment 5. See item D 6. Replenish 7. New engines are very tight during the 'running-in' period and moderate speeds should be maintained for the first 1,000 miles (1,500 km) 8. Rectify or renew 9. Adjust brakes 10. In the hands of the operator 11. In the hands of the operator 12. In the hands of the operator 13. In the hands of the operator 14. In the hands of the operator 15. Renew 16. Renew
G—OVERCOOLING	<ol style="list-style-type: none"> 1. Defective thermostat 2. Inaccurate temperature gauge 	<ol style="list-style-type: none"> 1. Renew 2. Renew

INDUCTION MANIFOLD

Remove and refit

NOTE: Refer to electronic fuel injection, section 19, for remove and refit of EFI induction manifold.

Removing

1. Drain the cooling system.
2. Remove the air cleaner.
3. Remove the engine breather filter.
4. Disconnect the throttle cable from the carburettor and manifold.

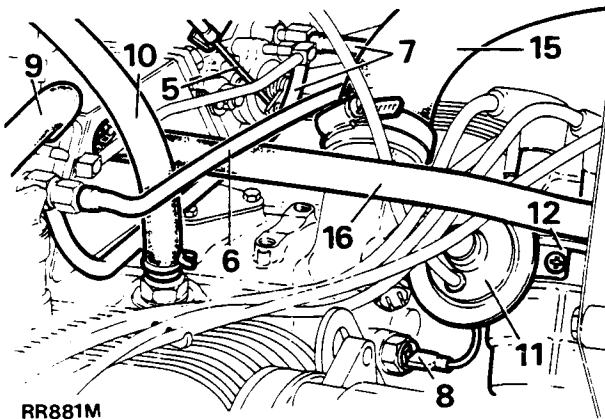

RR881M

5. Disconnect the choke cable from the carburettor.
6. Disconnect the fuel spill return pipe from the RH carburettor.
7. Remove the fuel supply pipe from the carburetters.

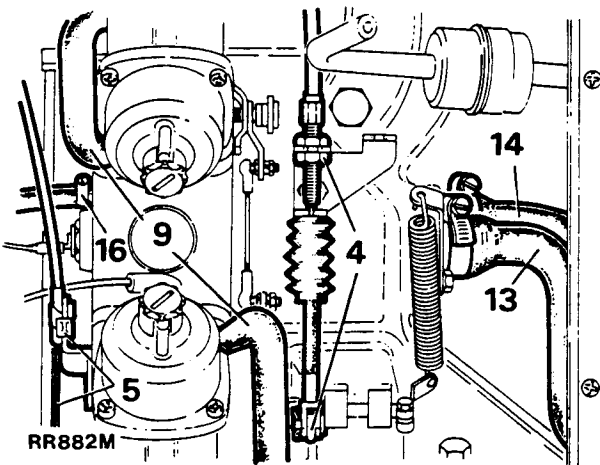

RR882M

8. Disconnect the lead from the water temperature transmitter.
9. Disconnect the flame trap hoses from the carburetters.
10. Disconnect the vacuum pipe for the brake servo.
11. Disconnect the vacuum pipe from the distributor.
12. Release the distributor cap.

13. Disconnect the inlet hose to the heater.
14. Disconnect the return hose from the heater.
15. Disconnect the return hose to the radiator.
16. Disconnect the return hose from the top of the induction manifold.

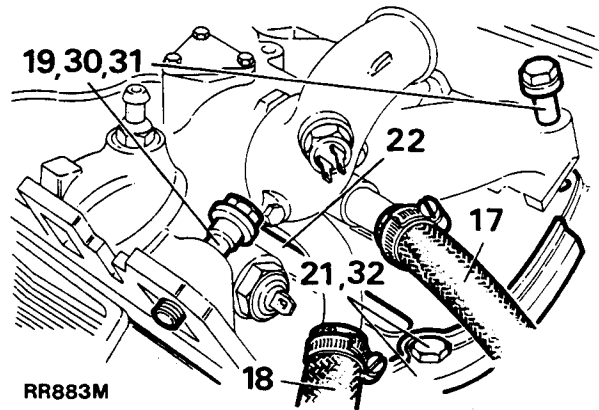

RR883M

17. Disconnect the outlet hose from the manifold.
18. Disconnect the heater return hose from the manifold.
19. Evenly slacken and withdraw twelve bolts and remove the manifold.
20. Wipe away any coolant lying on the manifold gasket.
21. Remove the gasket clamps.
22. Lift off the gasket.
23. Withdraw the gasket seals.

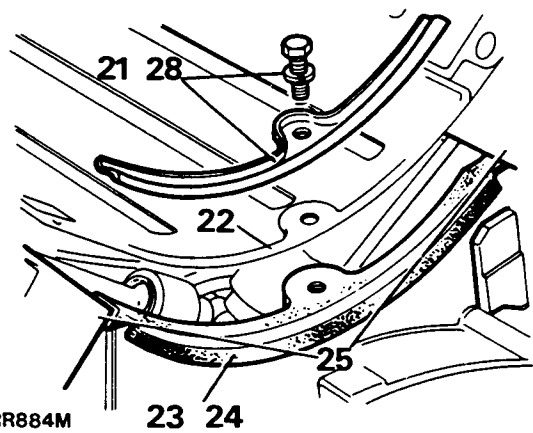

RR884M

Refitting

24. Using new seals, smear them on both sides with silicon grease.
25. Locate the seals in position with their ends engaged in the notches formed between the cylinder head and block.
26. Apply 'Hylomar' sealing compound SQ32M on the corners of the cylinder head, manifold gasket and manifold, around the water passage joints.
27. Fit the manifold gasket with the word 'FRONT' to the front and the open bolt hole at the front RH side.

Continued

28. Fit the gasket clamps but do not fully tighten the bolts at this stage.
29. Locate the manifold onto the cylinder head.
30. Clean the threads of the manifold securing bolts and then coat them with Thread Lubricant-sealer 3M EC776.
31. Fit all the manifold bolts and tighten them a little at a time, evenly, alternate sides working from the centre to each end. Finally tighten to the correct torque, see Data section.

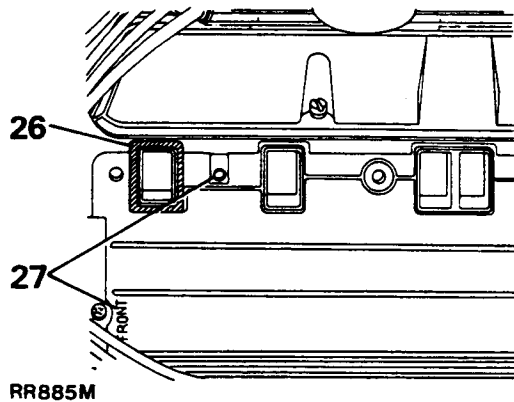

32. Tighten the gasket clamp bolts to the correct torque, see Data section.
33. Reverse 1 to 18.
34. Run the engine and check for water leaks.

EXHAUST SYSTEM COMPLETE

Remove and refit, 1 to 11

Front pipe, left hand 1 to 3 and 12

Front pipe, right hand 1 to 3 and 12

Silencer 4, 7, 8 and 13

Intermediate pipe 1 to 6 and 14

Tail pipe 7, 9, 10 and 15

NOTE: Ensure that no exhaust leaks are evident in either a new or an old exhaust system, as this will affect vehicle performance.

Removing

Note that a gasket is fitted between manifold and down pipe on EFI models—see inset.

1. Disconnect the front pipe(s) from the manifold(s).
2. Slacken the U-bolts securing the front and intermediate pipes.
3. Withdraw the front pipe(s).
4. Remove three bolts securing the intermediate pipe to the main silencer and withdraw the olive.
5. Remove the U-bolt from the pipe mounting bracket.
6. Withdraw the intermediate pipe.
7. Remove the U-bolt from the pipe mounting bracket
8. Withdraw the silencer.
9. Remove the U-bolt from the tail pipe mounting bracket.
10. Withdraw the tail pipe.

Refitting

NOTE: Apply Firegum Putty, Part No 15608 to the joints between the downpipe and intermediate pipe and between the silencer and tailpipe.

11. Complete system, reverse 1 to 10.
12. Front pipe, reverse 1 to 3.
13. Silencer, reverse 4, 7 and 8.
14. Intermediate pipe, reverse 1 to 6.
15. Tail pipe, reverse 7, 9 and 10.

EXHAUST SYSTEM COMPLETE

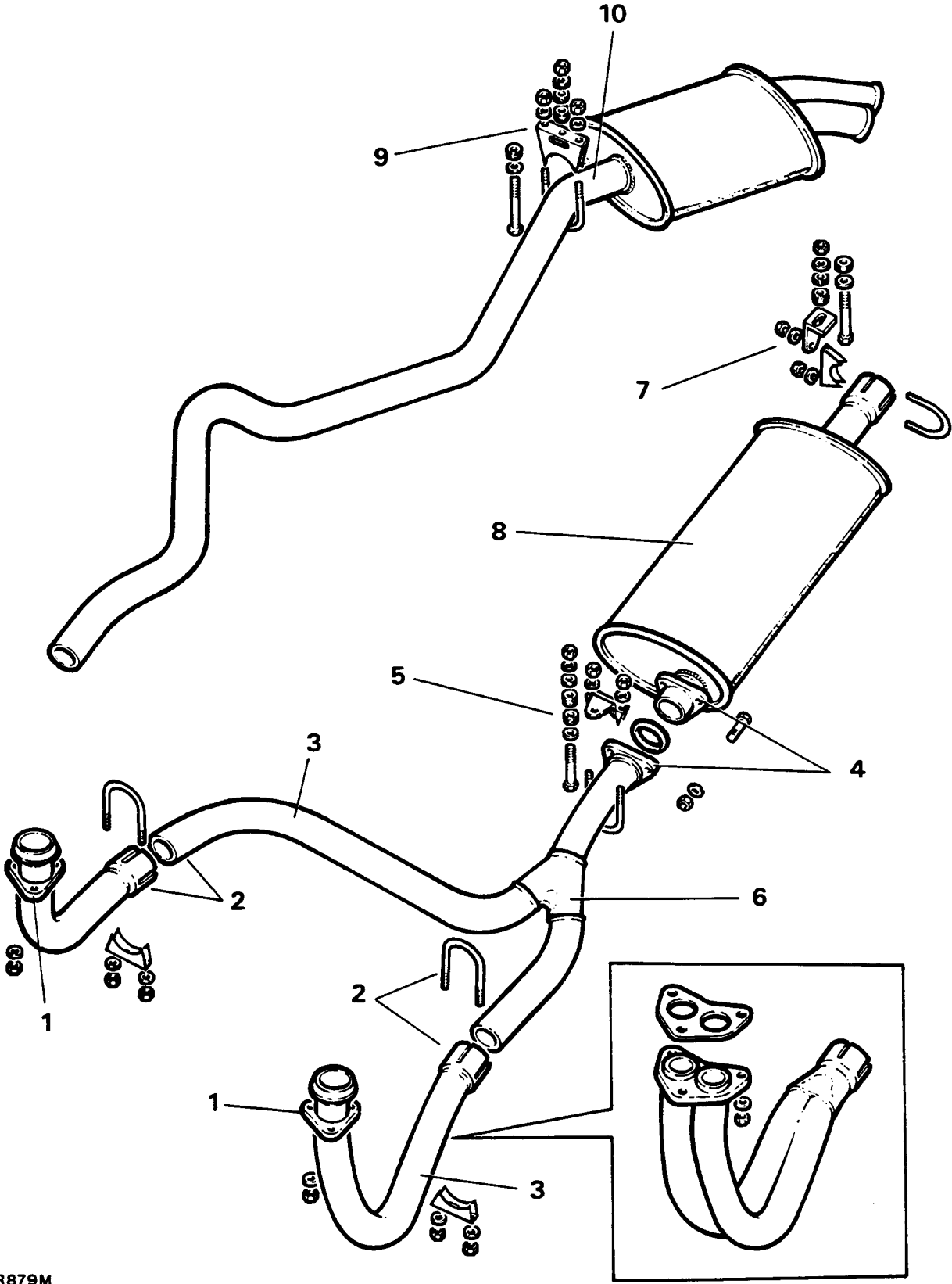

RR879M

EXHAUST MANIFOLD

Remove and refit

Left hand

Right hand

Removing

1. Disconnect the front exhaust pipe from the manifold and (where fitted) remove the hot air box.
2. Tap back the bolt locking tabs and remove eight bolts with lock tabs and washers.
3. Remove the manifold.

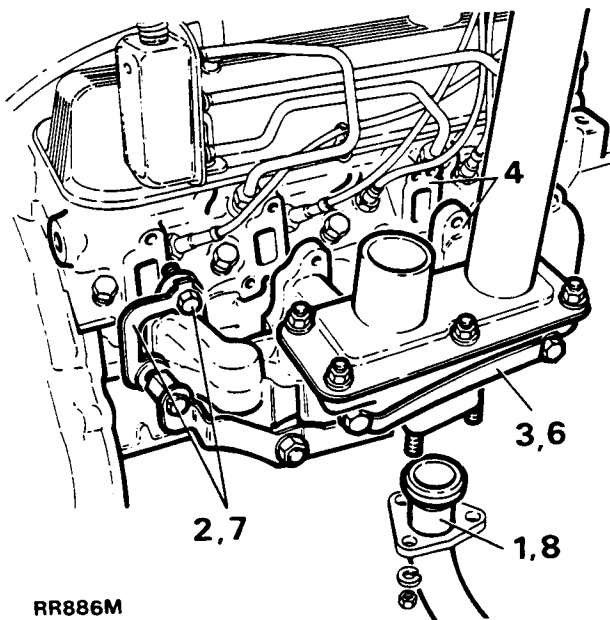

RR886M

Refitting

4. Ensure that the mating surfaces of the cylinder head and exhaust manifold are clean and smooth.
5. Coat the exhaust manifold (cylinder head mating faces) with 'Foliac J 166' or 'Moly Paul' anti-seize compound.
'Foliac J 166' is manufactured by Rocol Ltd., Rocol House, Swillington, Leeds, England.
'Moly Paul' is manufactured by K.S. Paul Products Ltd., Nobel Road, London N18.
6. Place the manifold in position on the cylinder head and fit the securing bolts, lockplates and plain washers. The plain washers are fitted between the manifold and lockplates.
7. Evenly tighten the manifold bolts to the correct torque, see Data section, and bend over the lockplate tabs.
8. Reconnect the front exhaust pipe.

CLUTCH ASSEMBLY**Overhaul****Clutch pressure plate**

Renew the pressure plate if the diaphragm spring fingers are worn or if the pressure plate shows signs of wear, cracks or burning.

Clutch driven plate

Renew the driven plate if the centre hub splines are worn or if the lining is contaminated, burned or unevenly worn.

Remove and refit

Service tool: 18G 79 clutch centralising tool

Removing

1. Remove the engine.
2. Mark the clutch cover fitted position relative to the flywheel.
3. Remove the clutch cover securing bolts, working evenly and diagonally.
4. Do not disturb the three bolts located in the apertures in the clutch cover.
5. Remove the clutch assembly.
6. Withdraw the clutch driven plate.

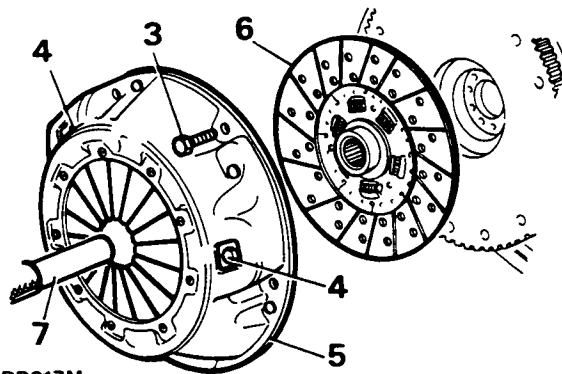

RR817M

Refitting

NOTE: As a precaution against the clutch plate sticking, lubricate the splines using Rocol MV 3 or Rocol MTS 1000 grease.

7. Reverse 5 and 6, aligning the assembly marks. Centralising tool 18G 79.
8. Secure the cover fixings evenly, working in a diagonal sequence. Finally tighten to the correct torque, see Data section.
9. Fit the engine.

HYDRAULIC SYSTEM**Bleed****Procedure**

NOTE: During the following procedure, keep the fluid reservoir topped up to avoid introducing air to the system. Use only the hydraulic fluid recommended in Section 09.

1. Attach a length of suitable tubing to the slave cylinder bleed screw.
2. Place the free end of the tube in a glass jar containing clutch fluid.
3. Slacken the bleed screw.

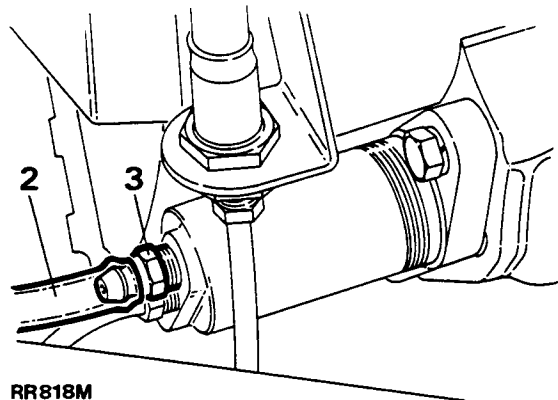

RR818M

4. Pump the clutch pedal, pausing at the end of each stroke, until the fluid issuing from the tubing is free of air with the tube free end below the surface of the fluid in the container.
5. Hold the clutch pedal down. Keeping the free end of the tube below the fluid, tighten the bleed screw.

MASTER CYLINDER

Remove and refit

Removing

1. Evacuate the hydraulic fluid from the system.
2. Disconnect the fluid pipe at the master cylinder. Plug the master cylinder fluid port and seal the end of the hydraulic pipe to prevent ingress of foreign matter.
3. Remove the lower fascia panel.
4. Remove the master cylinder fixings at the dash panel.
5. Remove the pivot bolt and sleeves to free the push rod from the clutch pedal.
6. Withdraw the master cylinder.

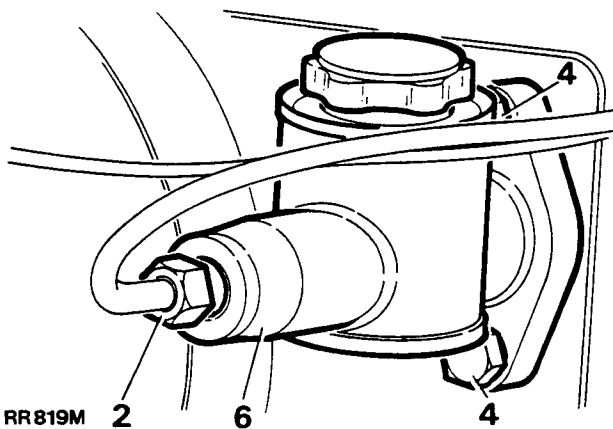

RR819M

Refitting

7. Fit the master cylinder and dash fixings.
8. Fit the push-rod to the pedal. Do not tighten the pivot bolt nut at this stage.

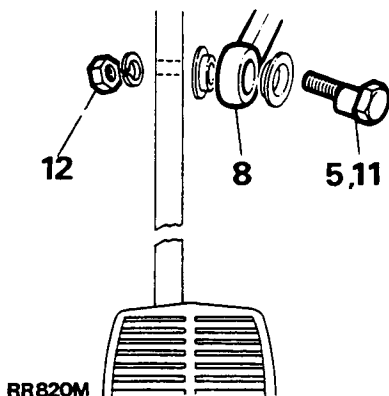

RR820M

9. Check the brake pedal setting.
10. Back off the lower stop bolt.
11. Align the clutch pedal to the same angle as the brake pedal by turning the pivot bolt and integral cam.

12. Tighten the pivot bolt securing nut.
13. Fully depress the pedal.
14. Adjust the lower stop bolt to touch the pedal then continue a further turn.

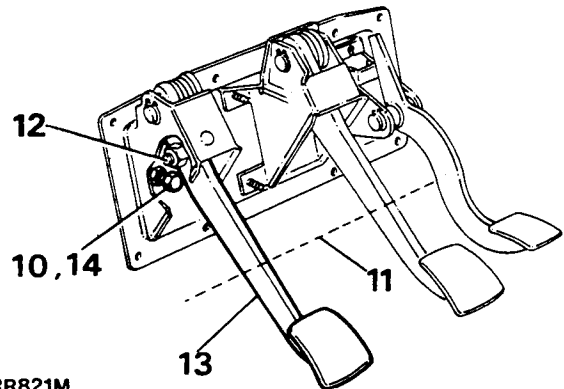

RR821M

15. Fit the fluid pipe to the master cylinder.
16. Bleed and replenish the hydraulic system.
17. Fit the lower fascia panel.

MASTER CYLINDER

Overhaul

1. Remove the master cylinder.

Dismantling

2. Pull back and remove the rubber sealing boot from the pushrod.
3. Depress the push-rod and extract the circlip.
4. Withdraw the push-rod assembly.
5. Withdraw the piston assembly.
6. Withdraw the retainer and spring.

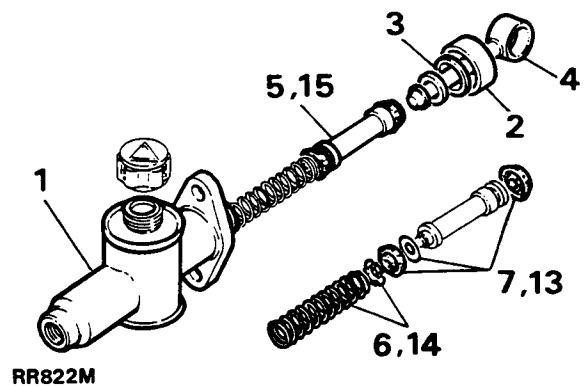

RR822M

7. Remove the two piston seals and the piston washer.

Inspecting

8. Clean all the components thoroughly using new hydraulic fluid. Dry, using a lint-free cloth.

9. Examine the cylinder bore and piston, ensure that they are smooth to the touch with no corrosion, score marks or ridges. If there is any doubt, fit new replacements.
10. Replace the seals and rubber boot using new components. These items are all included in the master cylinder overhaul kit.
11. Ensure that the feed and by-pass ports are not obstructed.

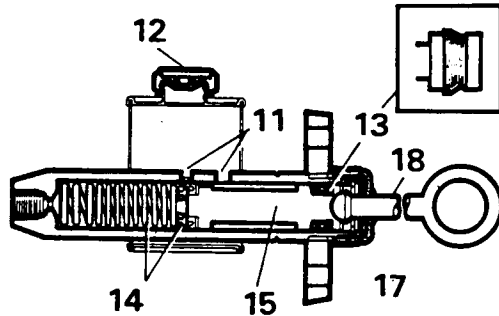

RR823M

12. Ensure the reservoir cap vent is clear.

Assembling

NOTE: Scrupulous cleanliness is essential, ensure that the hands are free of grease or dirt. Lubricate the cylinder bore and rubber seals with new hydraulic fluid before assembling.

13. Fit a new piston washer and the thinner of the two piston seals, lip last, over the piston nose, up against the drilled piston head. Fit the thicker seal into the piston groove with the lip facing towards the seal at the opposite end.
14. Insert the spring and retainer into the master cylinder bore.
15. Insert the piston and seal assembly, ensuring that the seal lips do not bend back.
16. Reverse 3 and 4, correctly locating the circlip.
17. Gently stretch the new rubber boot over the push-rod, pack with rubber grease, and fit securely into its locating groove.
18. Operate the push-rod several times to ensure free movement of the internal components.
19. Fit the master cylinder.

RELEASE BEARING ASSEMBLY

Remove and refit

Removing

1. Remove the engine.
2. Remove the clutch slave cylinder.
3. Withdraw the retainer staple.

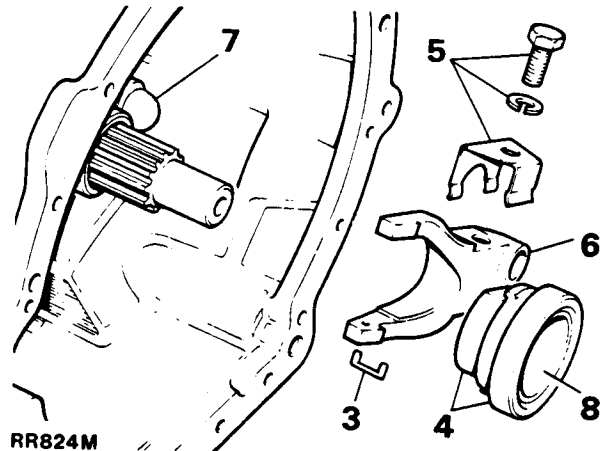

RR824M

4. Withdraw the bearing and sleeve. If required, press the bearing off the sleeve. Fit the replacement bearing with the domed face outwards from sleeve.
5. Remove the spring clip and fixings.
6. Withdraw the release lever assembly.

Refitting

7. Smear the pivot with grease and fit the release lever and retain with the spring clip and bolt.
8. Smear the release bearing sleeve inner diameter with molybdenum disulphide base grease.
9. Reverse 1 to 4.

CLUTCH PEDAL

Remove and refit

Removing

1. Remove the lower fascia panel.
2. Remove the pedal bracket fixings at the cab dash panel.
3. Disconnect the brake fluid pipes and electrical connection at the brake master cylinder.
4. Disconnect the fluid pipe at the clutch master cylinder.
5. Withdraw the pedal bracket assembly into the engine compartment.

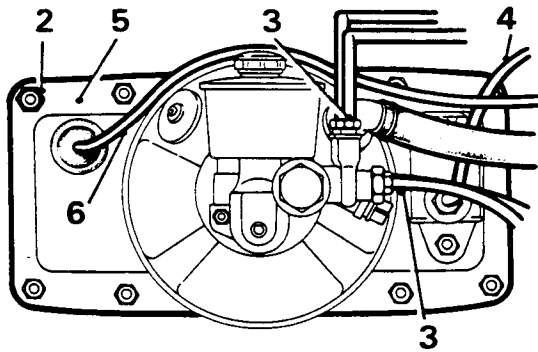

RR825M

6. Disconnect the accelerator control cable at the pedal.
7. Withdraw the pedal bracket assembly from the vehicle.
8. Remove the pivot bolt nut.
9. Withdraw the pivot bolt and bearing sleeves which retain the master cylinder push-rod.
10. Remove the pedal spindle circlip.
11. Withdraw the spindle.
12. Lift out the return spring.
13. Withdraw the pedal.
14. If required, press out the spindle bushes. Press in replacements and lubricate.

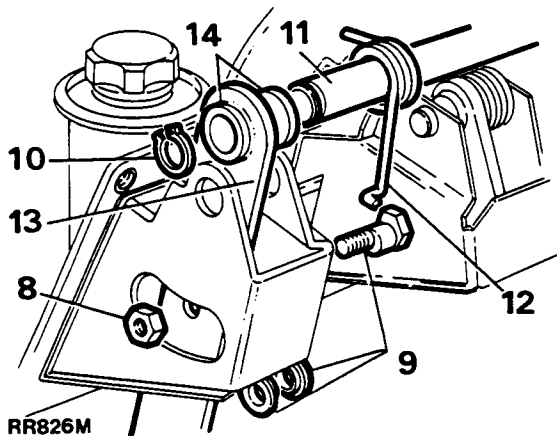

RR826M

Refitting

15. Reverse 9 to 13.
16. Loosely fit the pivot bolt nut.
17. Align the clutch pedal to the same angle as the brake pedal by turning the pivot bolt and integral cam.
18. Tighten the pivot bolt securing nut.

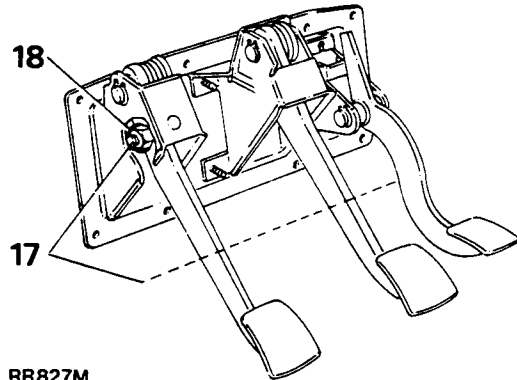

RR827M

19. Fit the accelerator cable.
20. Offer the pedal bracket assembly and joint washer to the dash panel. Avoid damaging the brake light switch.
21. Reverse 1 to 4.
22. Bleed the brake system.
23. Bleed the clutch system.

SLAVE CYLINDER

Remove and refit

Removing

1. Evacuate the clutch system fluid at the slave cylinder bleed valve.
2. Disconnect the fluid pipe.
3. Remove the two securing bolts and withdraw the slave cylinder and backing plate.
4. If the dust cover is not withdrawn with the slave cylinder, withdraw it from the bell housing.

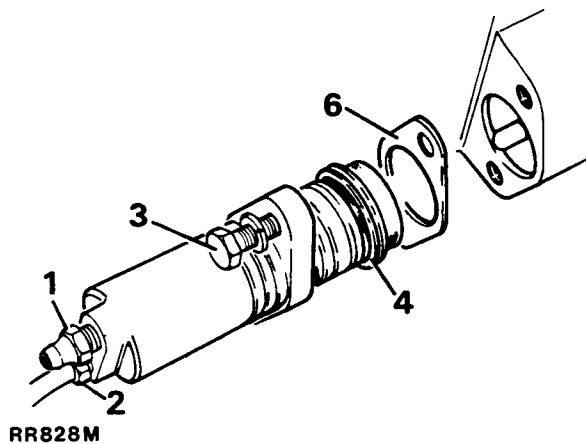

Refitting

5. Withdraw the dust cover and backing plate from the slave cylinder.
6. Coat both sides of the backing plate with Hylomar P232M waterproof jointing compound.
7. Locate the backing plate and dust cover in position on the slave cylinder.
8. Fit the slave cylinder, engaging the push-rod through the centre of the dust cover and with the bleed screw uppermost.

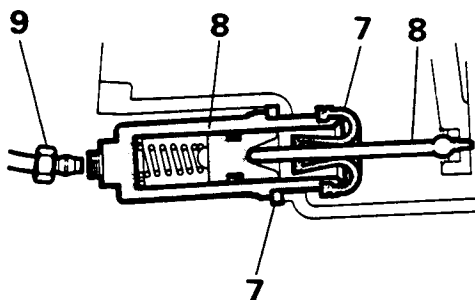

9. Reconnect the fluid pipe.
10. Replenish and bleed the clutch hydraulic system.
11. Check for fluid leaks with the pedal depressed and also with the system at rest.

SLAVE CYLINDER

Overhaul

1. Remove the slave cylinder.

Dismantling

2. Withdraw the rubber boot.
3. Withdraw the push-rod.
4. Remove the circlip.
5. Extract the piston and seal assembly, applying low pressure air to the fluid inlet if necessary.
6. Withdraw the spring.
7. Remove the bleed valve.

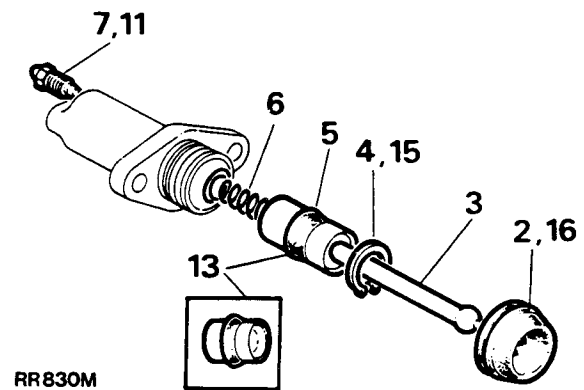

Inspecting

8. Clean all components thoroughly using new hydraulic fluid, and dry using lint-free cloth.
9. Examine the cylinder bore and piston which must be free from corrosion, scores and ridges.
10. Replace the seal and rubber boot using the appropriate repair kit.

Assembling

NOTE: Scrupulous cleanliness is essential, ensure that hands are free of grease or dirt.

11. Fit the bleed valve. Do not overtighten.
12. Lubricate the seals, piston and bore using new hydraulic fluid.
13. Fit the seal into the piston groove, the lip of the seal towards the fluid inlet end of the cylinder.
14. Enter the piston assembly, spring first, into the cylinder bore. Ensure that the seal lip does not fold back.
15. Secure with the circlip.
16. Fill the rubber boot with rubber grease.
17. Reverse 1 to 3.

