

**BRAKE SYSTEM**

**Description**

The hydraulic braking system fitted to the Range Rover is of the dual line type, incorporating primary and secondary hydraulic circuits.

**NOTE:** References made to primary and secondary do not imply main service brakes or emergency brakes but denote hydraulic line identification.

The brake pedal is connected to a vacuum-assisted mechanical servo which in turn operates a tandem master cylinder. The front disc brake calipers each house four pistons, the lower pistons are fed by the primary hydraulic circuit, the upper pistons by the secondary hydraulic circuit. The rear disc brake calipers each house two pistons and these are fed by the secondary hydraulic circuit via a pressure reducing valve.

A brake failure switch incorporated in the master cylinder will illuminate a panel warning light if a failure occurs in either the primary or secondary hydraulic circuits.

*Continued*



PRIMARY HYDRAULIC CIRCUIT - EMERGENCY BRAKE



SECONDARY HYDRAULIC CIRCUIT - SERVICE BRAKE

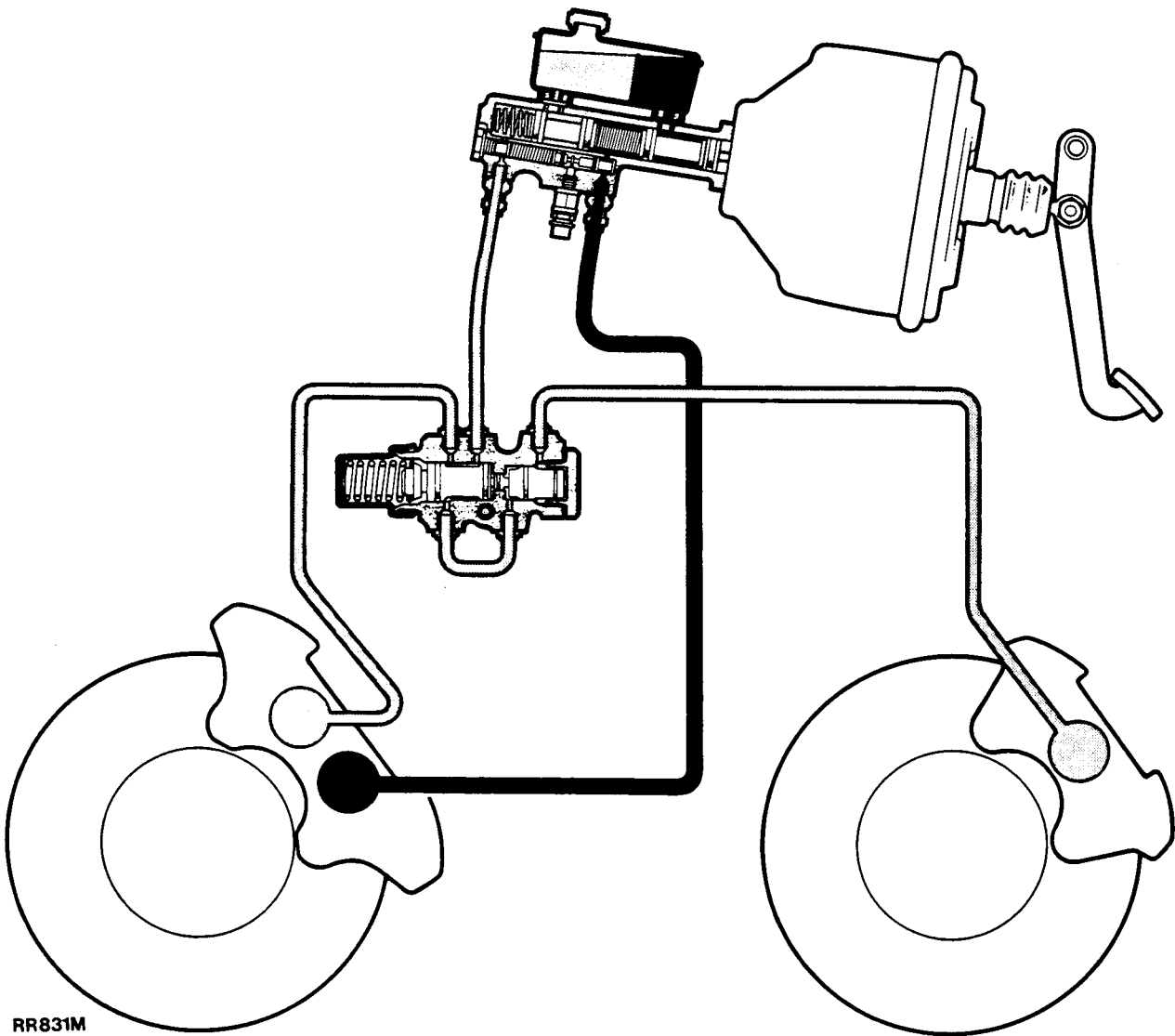

RR831M

The brake fluid reservoir is divided, the front section (section closest to the servo) feeds the primary circuit and the rear section feeds the secondary circuit. Under normal operating conditions both the primary and secondary hydraulic circuits operate simultaneously on brake pedal application. In the event of a failure in the primary circuit the secondary circuit will still function and operate front and rear calipers. Alternatively, if the secondary circuit fails, the primary circuit will still function and operate the lower pistons in the front calipers.

If the servo should fail, both hydraulic circuits will still function but would require greater pedal pressure.

The hand-operated transmission brake is completely independent of the hydraulic circuits.

Brake pad wear sensors are incorporated into the front right-hand side, inboard brake pad and rear left-hand side, inboard pad. The sensors will illuminate a brake pad wear warning light in the instrument binnacle, when pad thickness has been reduced to approximately 3 mm (0.118 in).

---

## HOSES

- 1 Front left-hand flexible hoses
- 2 Front right-hand flexible hoses
- 3 Intermediate flexible hose

## PIPES

- 4 Feed to front left-hand hose connector
- 5 Feed to front right-hand hose connector
- 6 Feed to front left-hand caliper
- 7 Feed to front right-hand caliper
- 8 Feed to rear left-hand caliper
- 9 Feed to rear right-hand caliper
- 10 Feed to two-way connector
- 11 Feed to intermediate hose
- 12 Feed to pressure reducing valve
- 13 Transfer pipe—pressure reducing valve
- 14 Brake failure warning switch

**BRAKE SYSTEM LAYOUT—RIGHT-HAND STEERING**

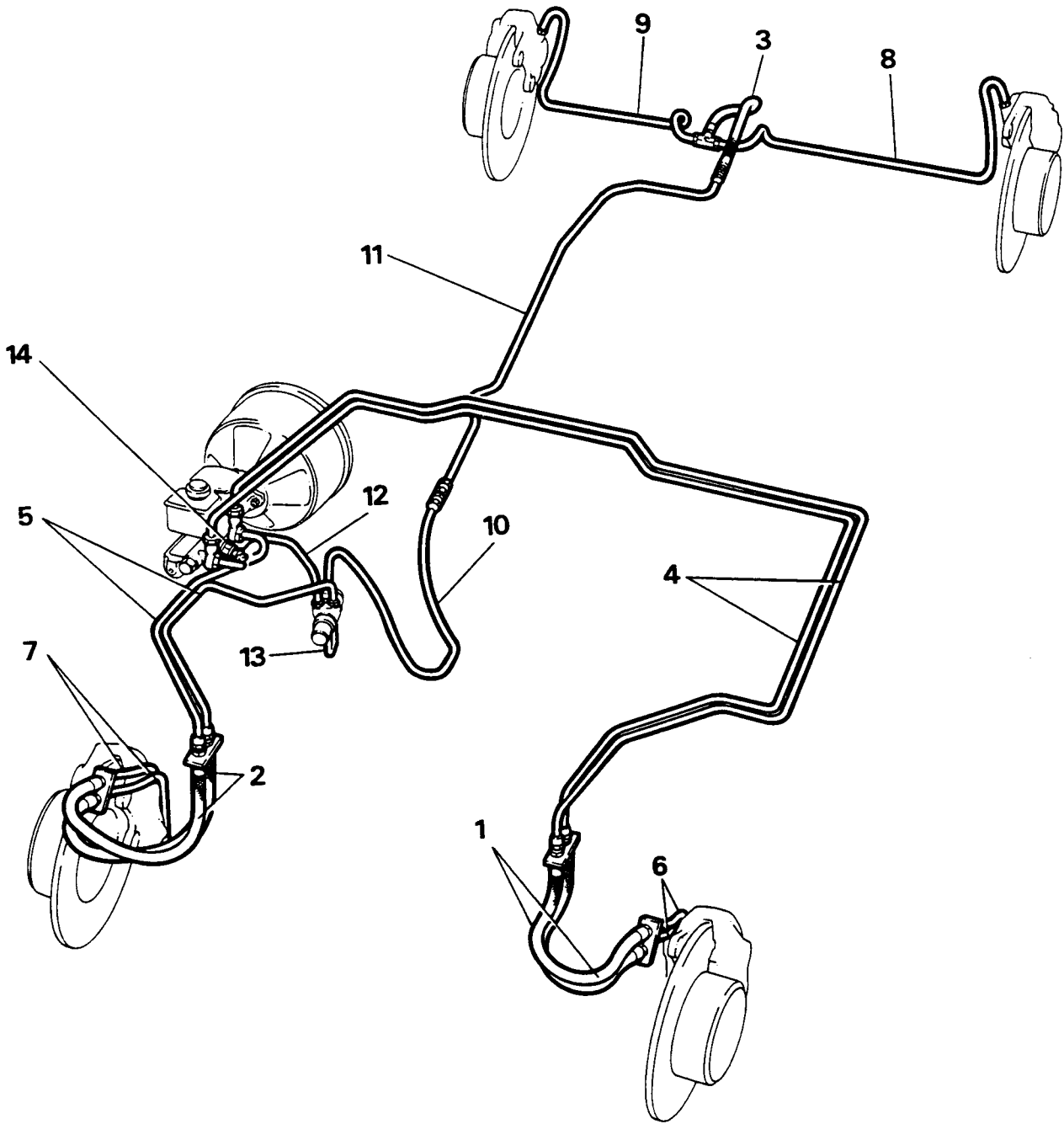

RR832M

**BRAKES**

**Bleed**

The hydraulic system comprises two completely independent sections. The rear calipers and the upper pistons in the front calipers form the secondary section, while the lower pistons in the front calipers form the primary section. The following procedure covers bleeding the complete system, but it is permissible to bleed one section only if disconnections are limited to that section.

Bleeding will be assisted if the engine is run or a vacuum supply is connected to the servo.

**WARNING: IF THE ENGINE IS RUNNING DURING THE BRAKE BLEEDING PROCESS ENSURE THAT NEUTRAL GEAR IS SELECTED AND THAT THE HANDBRAKE IS APPLIED.**

When bleeding any part of the secondary section, almost full brake pedal travel is available. When bleeding the primary section only, brake pedal travel will be restricted to approximately half.

Before commencing to bleed the system it is necessary to slacken off the brake failure warning switch to prevent the shuttle valve restricting the hydraulic fluid flow.

1. Disconnect the leads from the switch.
2. Unscrew the switch and insert the 'C' washer between the switch and master cylinder before depressing the brake pedal.
3. After completion of bleeding, screw in the switch and tighten to the correct torque. See 'Data section'.

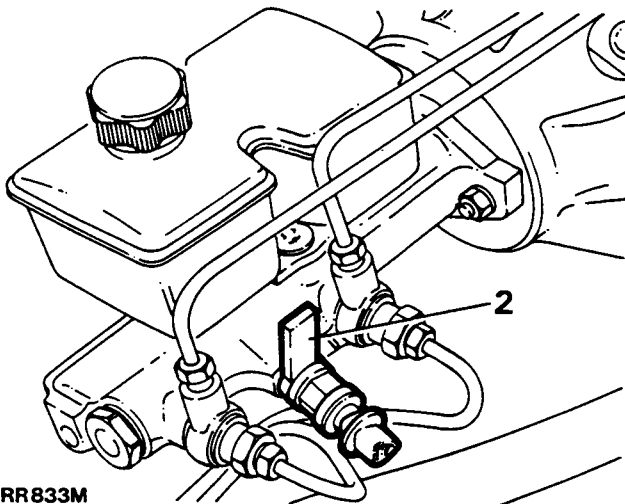

**NOTE: When bleeding the system commence with the caliper furthest from the master cylinder and bleed from the screw on the same side as the fluid inlet pipes, then close the screw and bleed from the screw on the opposite side of the same caliper. Tighten the bleed screws to the correct torque. See 'Data section'.**

**Bleeding**

1. Fill the fluid reservoir with the correct fluid, see 'Data section'.

**NOTE: The correct fluid level must be maintained throughout the procedure of bleeding.**

2. Connect a bleed tube to the bleed screw on the rear caliper furthest from the master cylinder.
3. Submerge the free end of the bleed tube in a container of clean brake fluid.
4. Slacken the bleed screw.
5. Operate the brake pedal fully and allow to return.

**NOTE: Allow at least five seconds to elapse with the foot right off the pedal to ensure that the pistons fully return before operating the pedal again.**

6. Repeat 5 until fluid clear of air bubbles appears in the container, then keeping the pedal fully depressed, tighten the bleed screw.
7. Remove the bleed tube and replace the dust cap on the bleed screw.

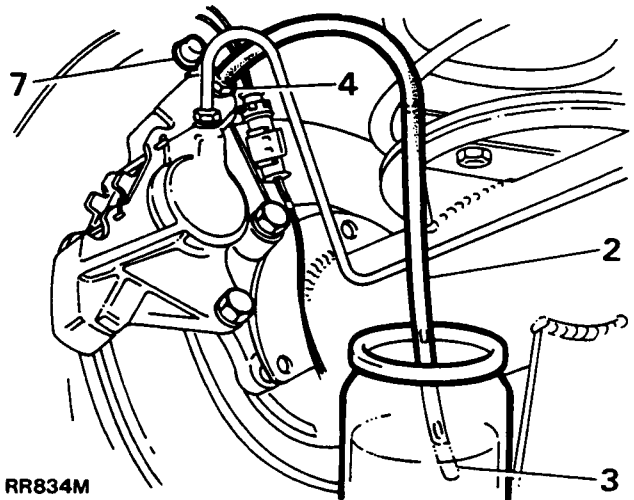

8. Repeat 1 to 7 for the other rear caliper.
9. Remove the front wheel on the side furthest from the master cylinder.

10. Connect a bleed tube to the primary bleed screw on the front caliper furthest from the master cylinder.
11. Connect a bleed tube to the secondary bleed screw on the same side of the caliper as the primary screw.
12. Repeat 3 to 7 for the front caliper, bleeding from the two screws simultaneously.
13. Connect a bleed tube to the other screw on the front caliper furthest from the master cylinder.

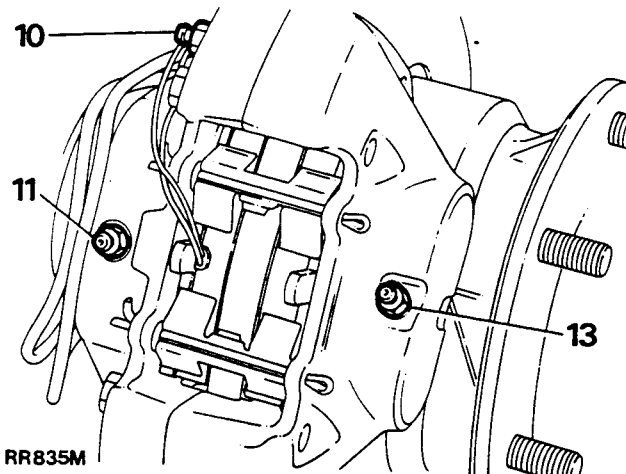

14. Repeat 3 to 7 for the second secondary screw on the front caliper.
15. Refit the front wheel.
16. Repeat 9 to 15 for the front caliper nearest the master cylinder.
17. Remove the 'C' washer and tighten the PDWA switch to the correct torque. See 'Data section'.

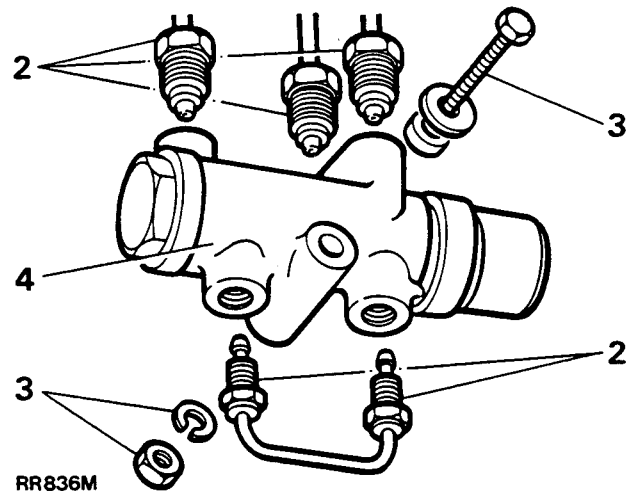

#### Refitting

5. Reverse the removal instructions.
6. Bleed the brake systems.

**NOTE:** The pressure reducing valve is not a serviceable item, in the event of a failure or damage, a new unit must be fitted.

## BRAKE PRESSURE REDUCING VALVE

### Remove and refit

#### Removing

1. Remove all dust, grime, etc. from the vicinity of the pressure reducing valve fluid pipe unions.
2. Disconnect the inlet and outlet fluid pipes from the pressure reducing valve. Plug the pipes and reducing valve ports to prevent the ingress of foreign matter.
3. Remove the nut, spring washer, bolt, plain washer and distance piece securing the reducing valve to the vehicle.
4. Withdraw the pressure reducing valve from the engine compartment.

## MASTER CYLINDER—OVERHAUL

**CAUTION:** Brake fluid is corrosive, if any fluid comes into contact with body paintwork, immediately wipe clean with a soft cloth.

1. Disconnect the brake pipes from the side of the master cylinder and plug the outlet ports.
2. Disconnect the electrical plug from the PDWA switch.
3. Remove the two nuts and spring washers securing the cylinder to the servo unit.

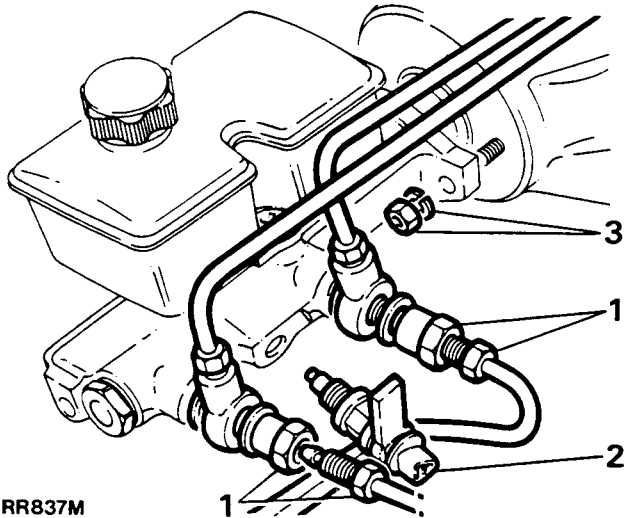

RR837M

4. Remove the reservoir filler cap and drain off the surplus fluid.
5. Remove the two screws securing the reservoir to the master cylinder.
6. Lift the reservoir off the master cylinder.
7. Prise the two reservoir sealing rubbers from the master cylinder.
8. Secure the master cylinder in a vice and push the primary piston down the bore and withdraw the secondary piston stop pin.

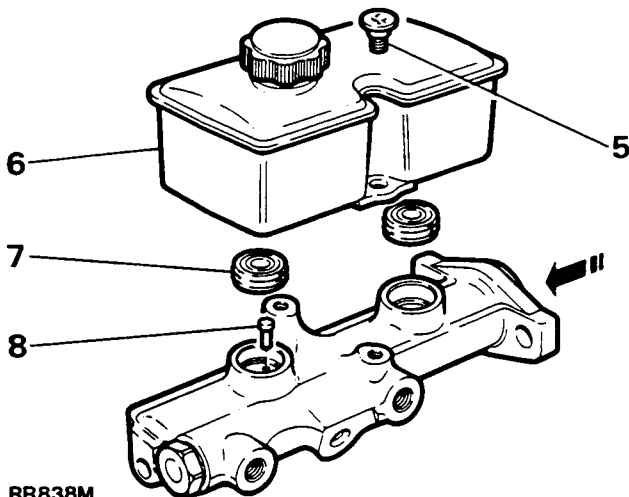

RR838M

9. Press down the primary piston and remove the circlip.
10. Withdraw the primary piston assembly.

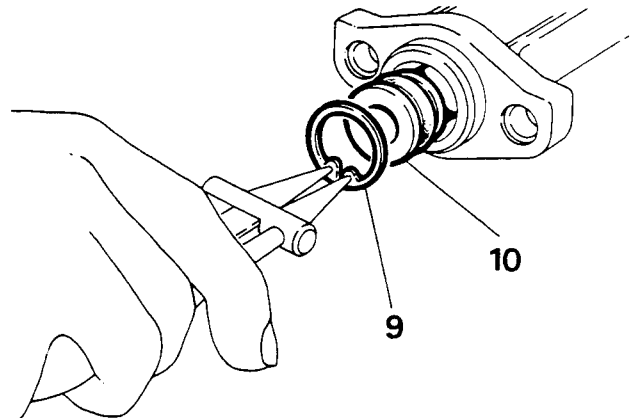

RR839M

11. Apply a high pressure air line to the secondary outlet port to expel the secondary piston assembly.
12. Remove the PDWA switch from the side of the master cylinder.
13. Remove the large end plug and copper washer retaining the shuttle valve in the master cylinder.
14. Apply a high pressure air line to the primary outlet port to expel the shuttle valve from its bore.

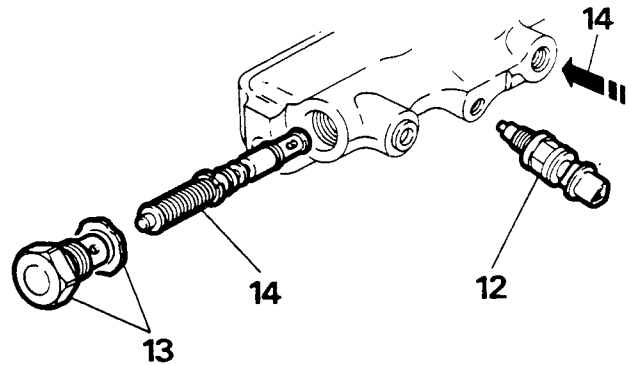

RR840M

*Continued*

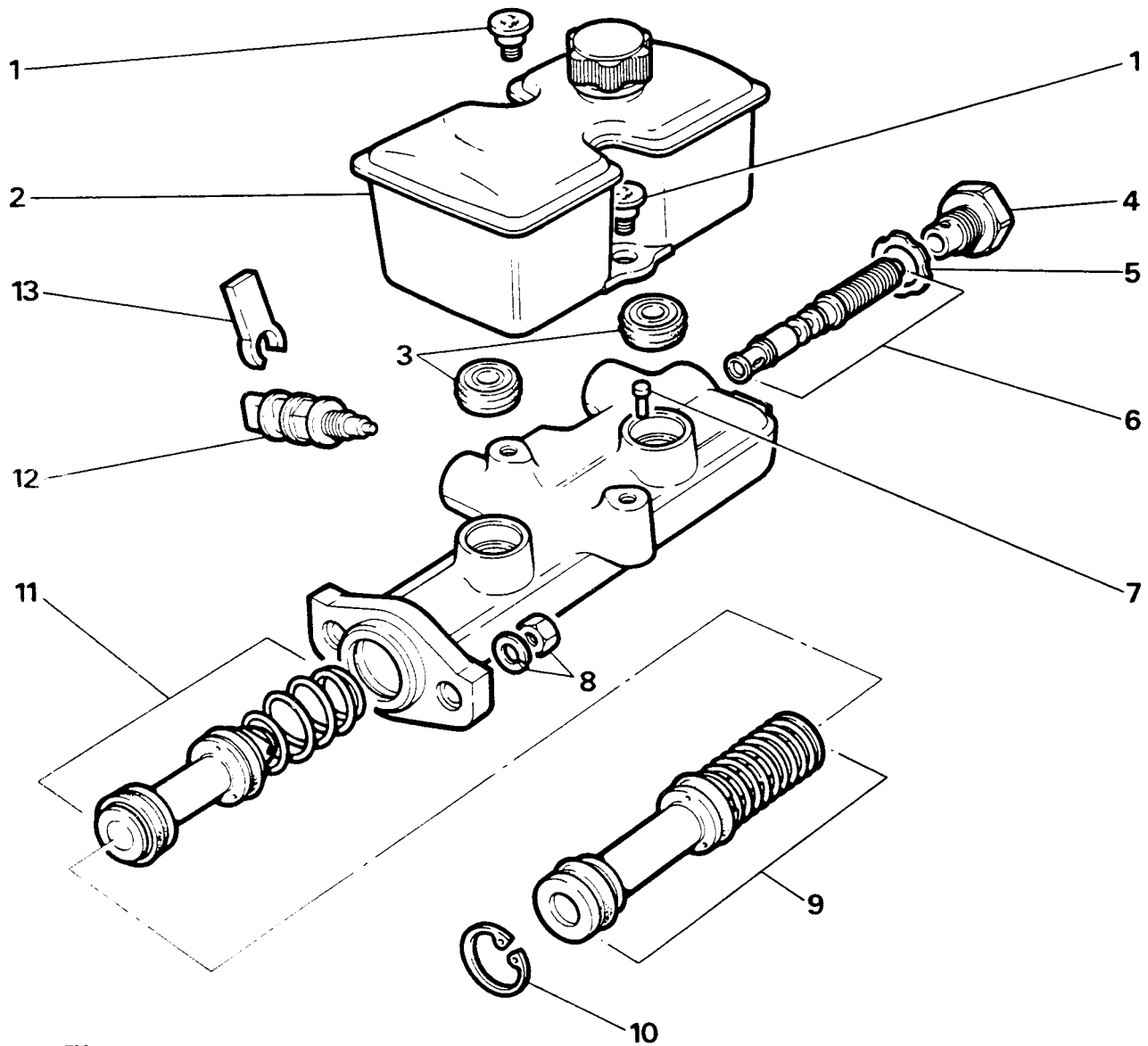

RR847M

**KEY TO MASTER CYLINDER**

1. Securing screws
2. Reservoir
3. Reservoir seals
4. End plug
5. Copper washer
6. Shuttle valve
7. Secondary piston stop pin
8. Nuts and washers securing cylinder to servo
9. Primary piston
10. Circlip
11. Secondary piston
12. PDWA switch
13. 'C' washer

## RENEWING PRIMARY PISTON SEALS

15. Remove the retaining screw from the primary piston and remove the following items:
- (A) Spring retainer.
  - (B) Piston spring.
  - (C) Circlip.
  - (D) Seal retainer.
  - (E) Recuperating seal.
  - (F) Washer.
16. Taking care not to damage the piston, prise off the outer seal.

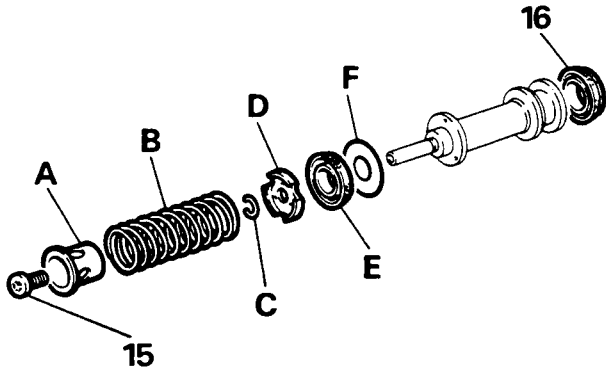

RR841M

17. Fit a new outer seal into its groove by squeezing the seal between the finger and thumb into an ellipse and press the raised part of the seal over the flange using the fingers of the other hand.
18. Fit a new recuperating seal and assemble the parts in the reverse order of removal. Compress the spring and secure the assembly with the retaining screw. Tighten the screw securely.

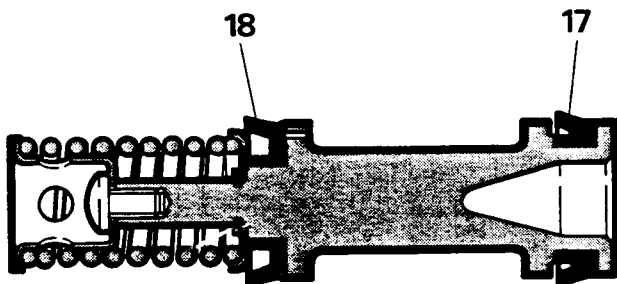

RR842M

## RENEWING SECONDARY PISTON SEALS

19. Remove the following items from the secondary piston:
- (A) Spring.
  - (B) Seal retainer.
  - (C) Recuperating seal.
  - (D) Washer.
20. Taking care not to damage the piston, prise off the outer seal.

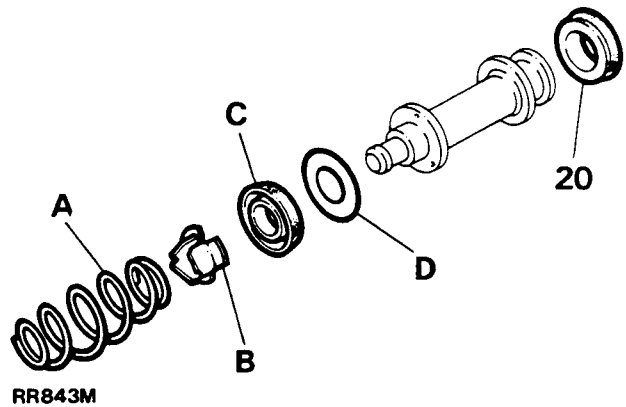

RR843M

21. Fit a new outer seal using the same procedure as for the primary piston outer seal by squeezing the seal between the finger and thumb into an ellipse and press the raised part of the seal over the flange using the fingers of the other hand.
22. Fit the recuperating seal assembly parts in the reverse order of removal.

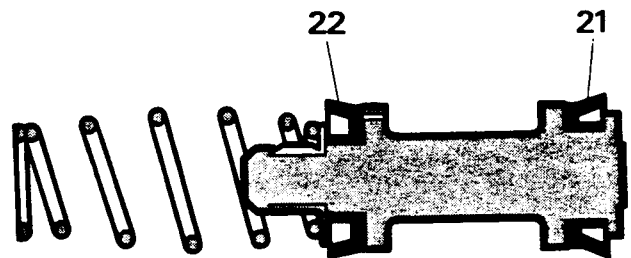

RR844M



### RENEW SHUTTLE VALVE 'O' RINGS

23. Carefully remove the two 'O' rings from the valve taking care not to damage the piston.
24. Fit new 'O' rings.

**NOTE:** The 'O' rings should not be rolled along the piston, but should be stretched slightly and eased down the piston and into the grooves.

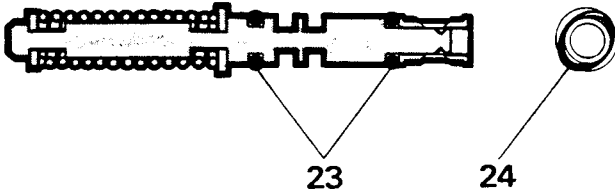

RR845M

26. Slowly press the piston down the bore and fit the secondary piston stop-pin.
27. Fit the primary plunger assembly using the same method as for the secondary plunger. Press the plunger down and secure the assembly with the circlip.
28. Lubricate the 'O' rings and fit the shuttle valve. Fit the end plug using a new copper sealing washer and tighten the plug securely.
29. Fit the plastic 'C' washer to the end of the PDWA switch and screw the switch into the master cylinder.
30. Fit new seals to the bottom of the reservoir.
31. Press the reservoir into the top of the master cylinder and secure in position with the two retaining screws.
32. Fit the master cylinder to the servo and secure with the two nuts and spring washers and tighten to the correct torque. See 'Data section'.
33. Bleed the brakes. After final bleed remove the 'C' washer from the PDWA switch and tighten the switch to the correct torque. See 'Data section'.

### ASSEMBLING MASTER CYLINDER

It is important that the following instructions are carried out precisely, otherwise damage could be caused to the new seals when inserting the plungers into the cylinder bore. Generous amounts of new brake fluid should be used to lubricate the parts during assembly. Never use old fluid or any other form of cleaning and lubricating material. Cleanliness throughout is essential.

25. Clamp the cylinder in a vice and lubricate the secondary piston seals and cylinder bore. Offer the piston assembly to the cylinder until the recuperation seal is resting centrally in the mouth of the bore. Gently introduce the piston with a circular rocking motion, as illustrated. Whilst ensuring that the seal does not become trapped, ease the seal into the bore and slowly push the piston down in one continuous movement.

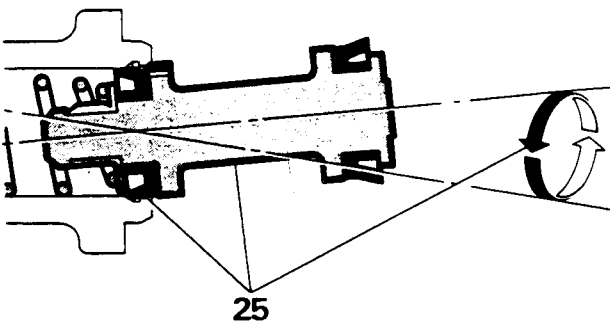

RR846M

### PEDAL ASSEMBLY—OVERHAUL

#### Remove the pedal assembly

1. Remove the lower fascia panel.
2. Disconnect the servo operating rod from the brake pedal.
3. Remove the four nuts and spring washers securing the brake pedal and servo assemblies to the engine compartment closure panel.
4. Withdraw the brake pedal assembly sufficient to disconnect the electrical leads from the stop light switch.
5. Lift the pedal assembly clear.

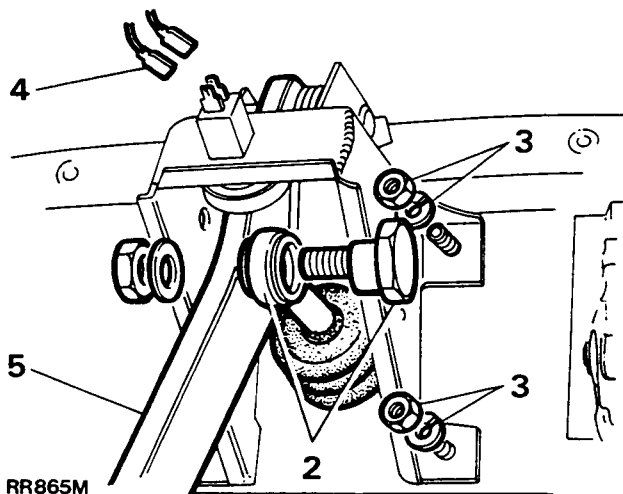

#### DISMANTLING

6. Disconnect the pedal return spring.
7. Remove the circlip from the 'D' shaped end of the pedal shaft.
8. Withdraw the pedal shaft.
9. Withdraw the pedal from the box.
10. Remove the bushes from the pedal pivot tube.

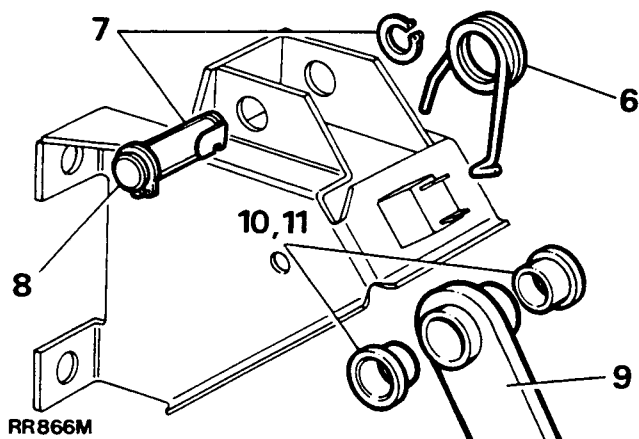

#### Assembling

11. Press the new bushes into the pedal pivot tube. If necessary, reamer the bushes to 15.87 mm plus 0.05 mm (.625 in plus .002 in).
12. Lightly oil the bushes and pedal shaft.

#### Refit the pedal assembly

13. Refit the assembly to the engine compartment closure panel, tighten the four nuts securely.
14. Connect the electrical leads to the stop light switch.
15. Connect the servo operating rod to the brake pedal with the pivot bolt eccentric, in the forward position. Do not fully tighten the pivot bolt nut.
16. Turn the pivot bolt to bring the brake pedal back until it just contacts the rubber buffer, then secure the pivot bolt nut.

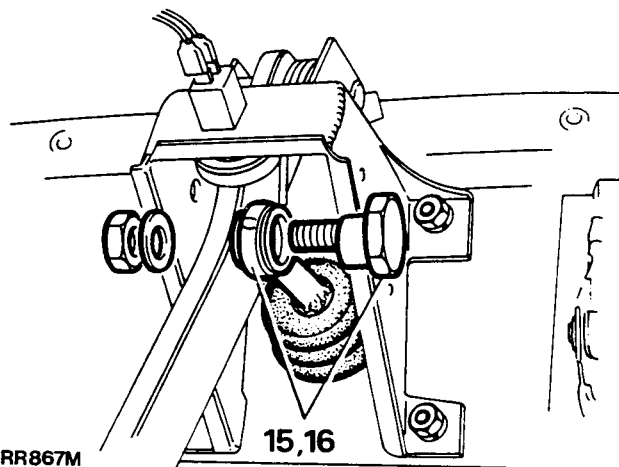

17. Refit the lower fascia.

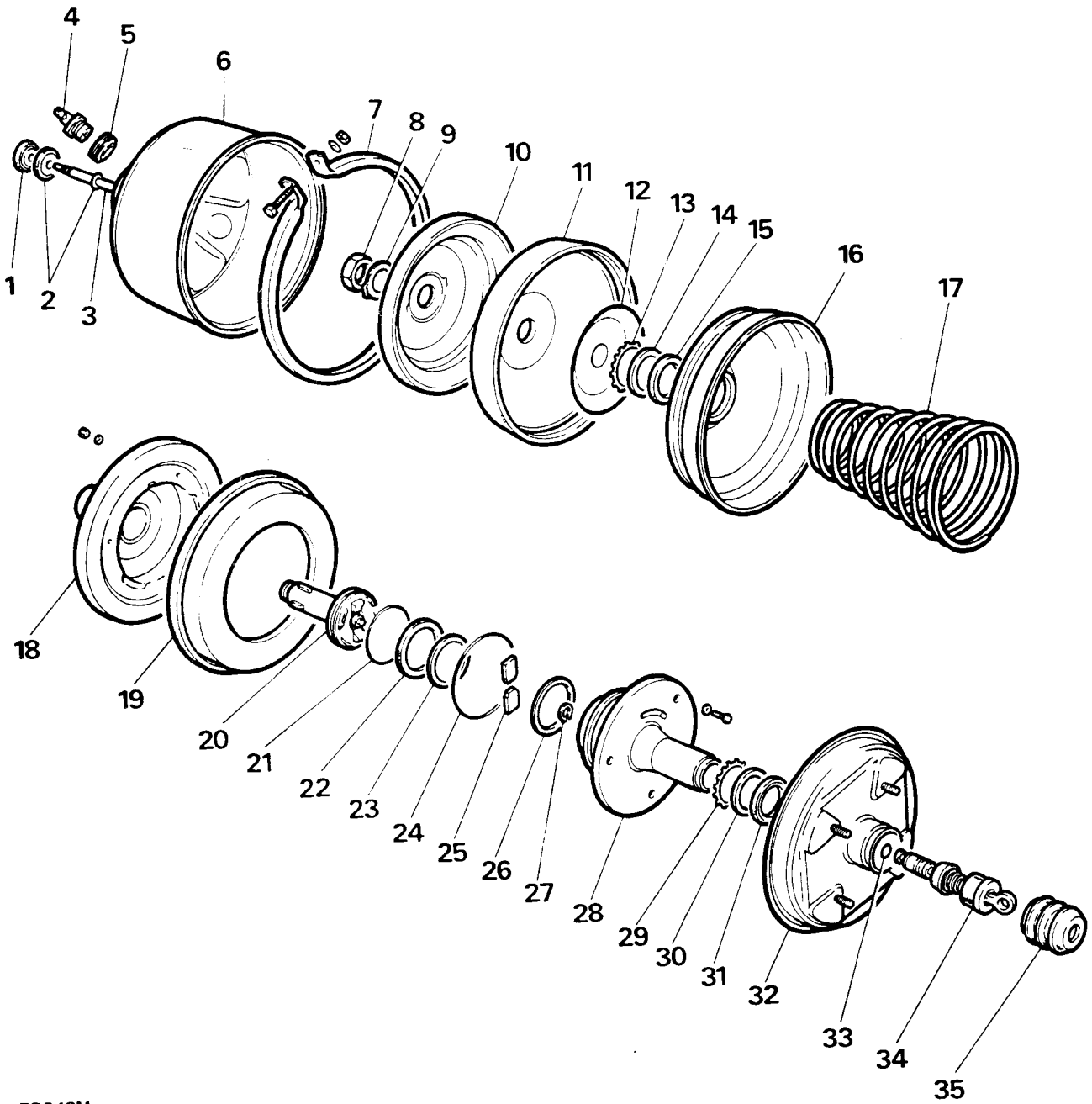

RR848M

**KEY TO BRAKE SERVO**

- |                     |                                |                             |
|---------------------|--------------------------------|-----------------------------|
| 1. Push rod seal    | 13. Bearing retainer           | 25. Levers                  |
| 2. Retainer         | 14. Nylon bearing              | 26. Bearing ring            |
| 3. Push rod         | 15. Seal                       | 27. Circlip                 |
| 4. Non-return valve | 16. Separator shell            | 28. Valve body              |
| 5. Seal             | 17. Spring                     | 29. Bearing retainer        |
| 6. Servo shell      | 18. Diaphragm support and tube | 30. Nylon bearing           |
| 7. Clamp ring       | 19. Diaphragm                  | 31. Seal                    |
| 8. Locknut          | 20. Reaction piston            | 32. Servo cover             |
| 9. Lock washer      | 21. Rubber 'O' ring            | 33. Rubber 'O' ring         |
| 10. Support plate   | 22. Sponge seal                | 34. Valve/push rod assembly |
| 11. Diaphragm       | 23. Backing ring               | 35. Rubber boot             |
| 12. Backing washer  | 24. Rubber 'O' ring            |                             |

**BRAKE SERVO—Overhaul**

**REMOVING THE SERVO**

1. Remove the master cylinder from the servo.
2. Disconnect the servo vacuum hose from the non-return valve.
3. Remove the lower fascia within the vehicle to gain access to the brake pedal linkage and servo retaining nuts located on the rear of the engine compartment closure panel.
4. Disconnect the brake pedal linkage.
5. Remove the four nuts with spring washers securing the servo to the closure panel.
6. Remove the servo from the engine compartment and place on a suitable clean bench.
7. Thoroughly clean the exterior of the servo.

**CAUTION: CARE MUST BE TAKEN TO ENSURE THAT ALL COMPONENTS ARE SCRUPULOUSLY CLEAN BEFORE UNDERTAKING THE OVERHAUL PROCEDURE. ANY DIRT OR GRIT WITHIN THE SERVO COULD RESULT IN DAMAGE TO THE DIAPHRAGMS.**

**DISMANTLING THE SERVO**

8. Before dismantling the servo lightly stamp identification marks on the servo shell, clamp ring and cover plate to aid the assembly procedure.

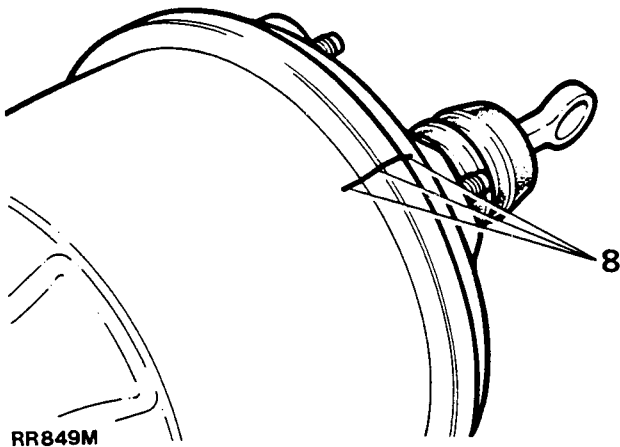

9. Remove the nut, bolt and plain washer securing the clamping to the servo.
10. Remove the rubber boot from the valve/push rod assembly.
11. Slide the servo cover off the valve body.
12. Using two screwdrivers inserted between the separator shell outer lip and servo shell, carefully lever the diaphragm assembly out of the shell.

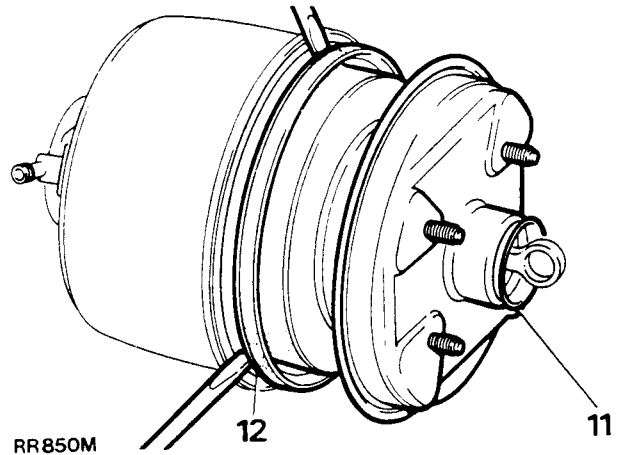

13. Bend back the tabs of the locking washer.

**WARNING: Assistance may be required, to hold the diaphragm assembly together whilst the locknut is released, to prevent the unit separating due to internal spring pressure.**

14. Remove the locknut and separate the assembly.

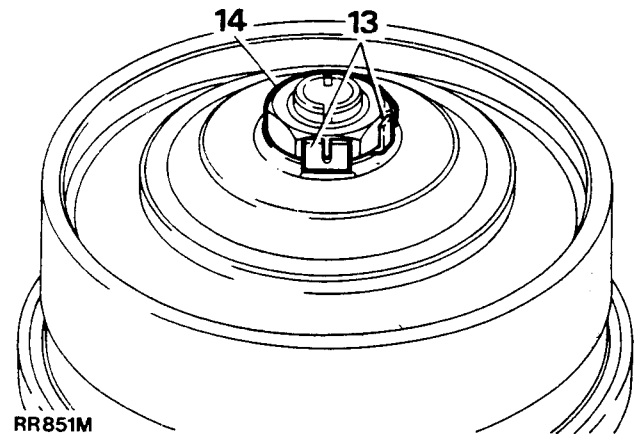

15. Remove the support plate, diaphragm and backing washer from the separator shell.
16. Prise the serrated bearing retainer out of the separator shell.
17. Remove the nylon bearing and rubber seal from the separator shell. Note their position for reassembly.

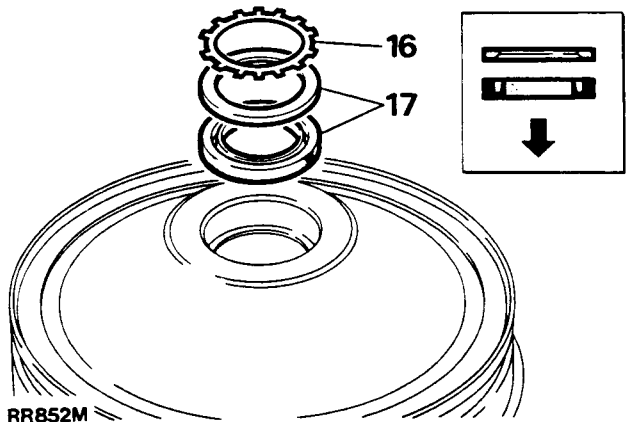

18. Remove the three screws, locknuts plain and fibre washers securing the diaphragm to the valve body.
19. Remove the diaphragm support and tube from the front of the diaphragm.
20. Remove the diaphragm from the valve body.
21. Pull the piston out of the valve body.
22. Remove the 'O' rings from the valve body and piston.

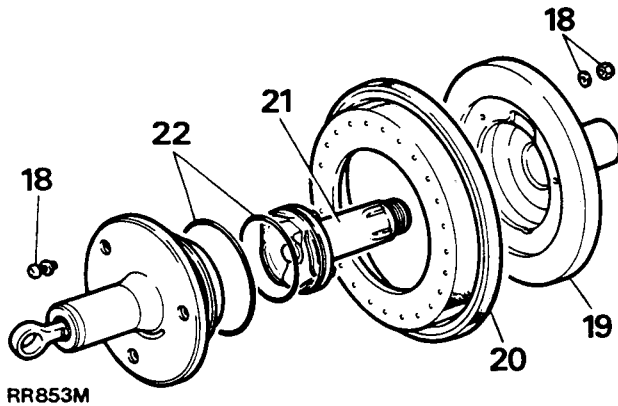

RR853M

23. Remove the sponge seal and backing ring from the valve body.
24. Lift out the two levers and remove the bearing ring.
25. Release the circlip securing the valve/push rod assembly in the valve body.

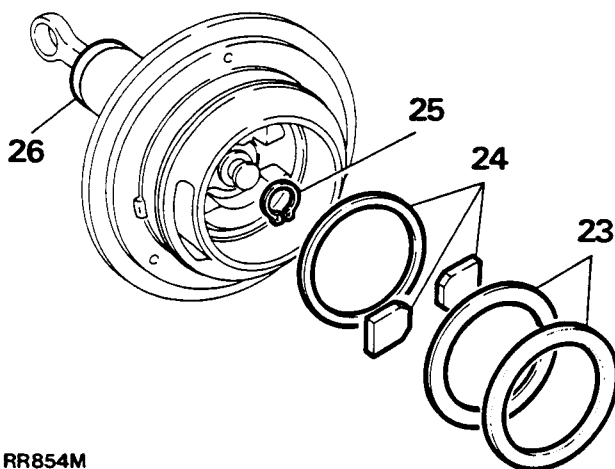

RR854M

26. Prise the end cap from the opposite end of the valve body and withdraw the valve/push rod assembly complete.
27. Remove the small 'O' ring from the assembly.

**NOTE:** The valve/push rod assembly cannot be further dismantled, if the seals and assembly are in a poor condition, renew the complete assembly.

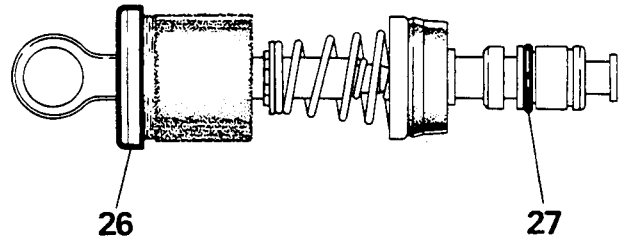

RR855M

28. Remove the push rod, seal, retainer and washer from the servo shell.

**NOTE:** If the push rod is to be renewed the operating length must be set after the servo has been assembled, see assembling procedure instruction number 61.

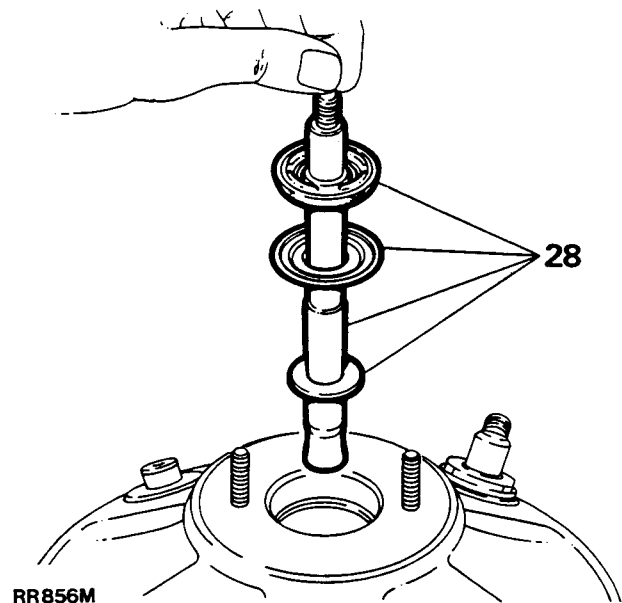

RR856M

*Continued*

## ASSEMBLE THE SERVO

Carefully inspect all parts for wear and damage. Scrupulous cleanliness of all parts of the servo is essential.

29. If a new valve/push rod assembly is being fitted it will be necessary to compress the spring located in the centre of the valve, to enable the circlip to be inserted into the groove, thus tensioning the seal.

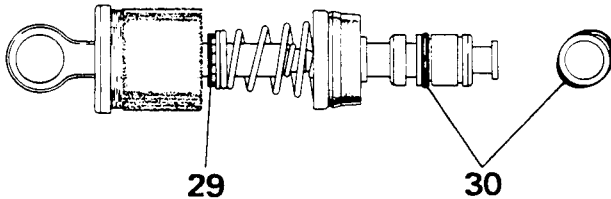

RR857M

30. Fit a new 'O' ring to the end of the valve. **DO NOT ROLL THE 'O' RING INTO THE GROOVE.** Carefully stretch the seal and ease it down the valve and into the groove.
31. Lubricate the seals with Lockheed disc brake lubricant and push the assembly fully into the bore of the valve body.
32. Clamp the eye of the assembly in a bench vice. Press the valve body down to expose the circlip groove at the end of the valve/push rod assembly and fit the circlip.

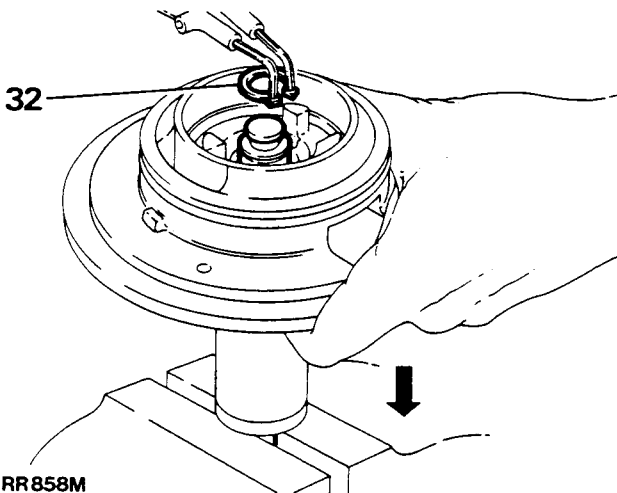

RR858M

33. Fit the bearing ring (thicker of the two rings), levers, backing ring and sponge seal to the valve body,

**NOTE: Ensure that the chamfered edges of the levers are fitted firmly into the groove at the end of the push rod assembly.**

34. Feed the sponge filter and felt pad into the opposite end of the valve body and press the end cap into position.
35. Lightly coat the new valve body 'O' ring with disc brake lubricant and ease the seal into the groove.
36. Lightly coat the new reaction piston 'O' ring with disc brake lubricant and ease the seal into the groove.
37. Push the piston into the valve body ensuring that the two projections on the piston are located over the levers in the valve body, push the piston firmly into position.

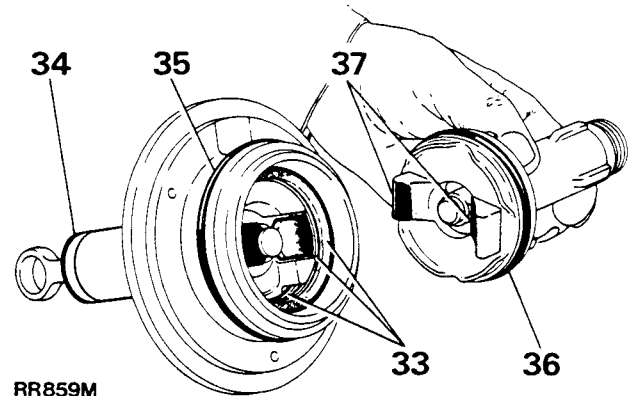

RR859M

38. Place the new diaphragm onto the valve body, locating the inner diaphragm bore onto the shoulder just outside the three bolt holes.

**NOTE: DO NOT LUBRICATE THE DIAPHRAGM.**

39. Fit the diaphragm support plate and tube to the valve body ensuring that the indent in the support plate lines up with the corresponding projection on the valve body.

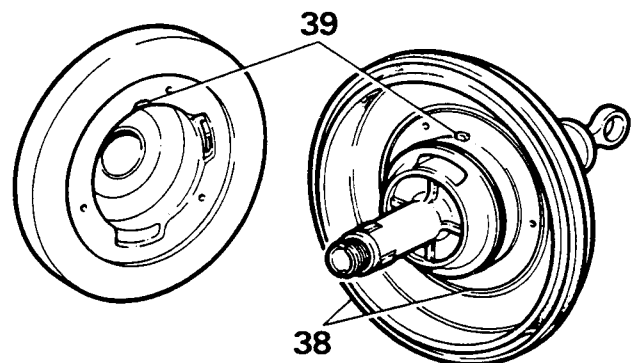

RR981M

40. Fit the three securing screws washers and nuts, entering the bolts from the valve body side.  
**NOTE: The fibre washer is inserted behind the screw head.**

**Tighten to the correct torque see 'Data Section'.**

41. Coat the new nylon bearing and seal with Lockheed disc brake lubricant and insert the seal into the separator shell, with the open edge of the seal facing upwards.
42. Fit the nylon bearing washer with the chamfered inner edge downwards.
43. Using a suitable service tool, example MS 550 press in the new retaining ring, convex side first, until the retainer sits firmly on the nylon bearing.

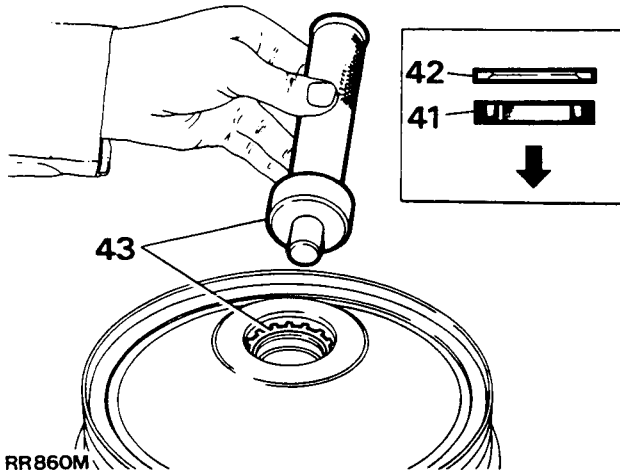

44. Fit the backing washer to the concave side of the separator shell diaphragm.
45. Fit the diaphragm to the separator shell, concave side first, locate the sealing lip over the edge of the separator.
46. Place the support plate onto the face of the diaphragm.
47. Mount the valve body into a bench vice.

**CAUTION: DO NOT OVERTIGHTEN THE VICE**  
Coat the support plate tube with disc brake lubricant.

48. Place the spring onto the valve body, largest diameter to sit on support plate and tube.
49. Holding the separator shell assembly together place it on to the top of the spring.
50. Compress the complete assembly until the thread on the end of the reaction piston protrudes beyond the separator shell assembly.
51. Fit a new tab washer and screw on the large nut.

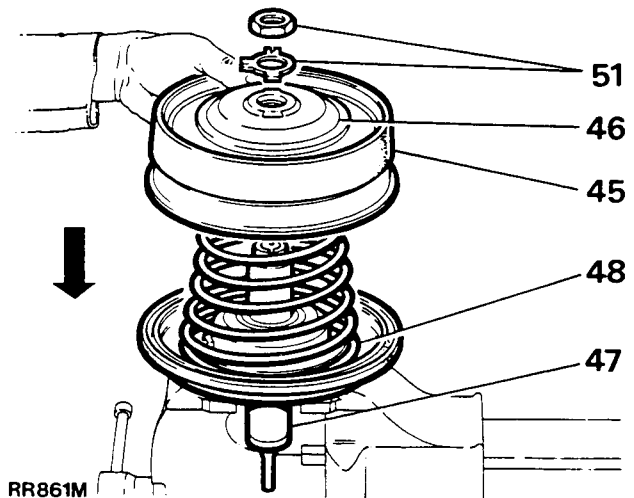

52. Remove the complete assembly from the vice. Tighten the locknut to the correct torque. See 'Data Section'.
53. Bend up the tabs on the lock washer.
54. Locate the outer edge of the valve body diaphragm into the indent around the separator shell and push the assembly into the servo vacuum shell, ensure that the diaphragm remains in position.

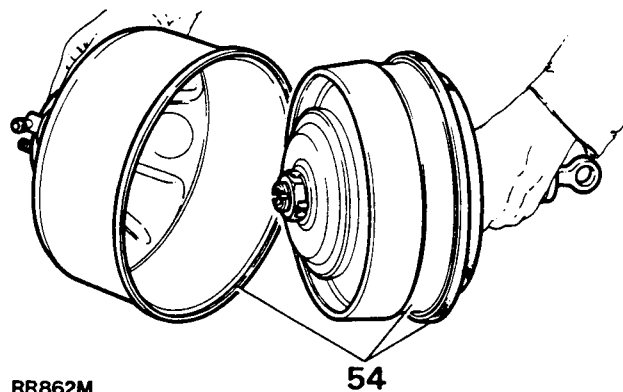

55. Coat the new nylon bearing and seal for the servo end cover with disc brake lubricant and press the seal into the cover.

**NOTE: THE OPEN FACE OF THE SEAL DOWNWARDS.**

56. Fit the new bearing retainer using a suitable service tool example: MS 550. Ensure the retainer sits firmly on top of the nylon bearing.
57. Lightly coat the valve body with disc brake lubricant ease the end cover onto the assembly and align the identification marks. Locate the beaded edge of the diaphragm between the end cover and servo shell.
58. Fit the clamp ring, bolt and nut, rotate the ring until the identification mark lines up with those on the servo unit. Tighten the clamp ring to the correct torque. See 'Data section'.
59. Fit a new rubber boot over the valve/push rod assembly.

*Continued*

60. Fit a new nylon washer, retainer and seal to the push rod, fit the push rod to the servo.

**NOTE:** Flat face of the seal to the bottom of the seal recess in the servo shell.

- (a). Nylon washer.  
 (b). Retainer.  
 (c). Seal.

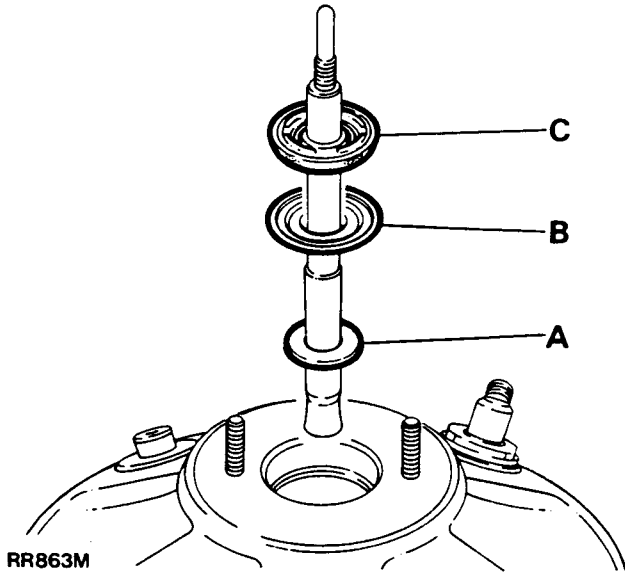

**NOTE:** If a new push rod is fitted, the operating length must be checked, if adjustment to the rod is required, adjust as follows.

61. Run two nuts down the studs at the master cylinder joint face of the servo. Set the top of the nuts to a dimension of 22.1–21.9 mm (0.871–0.861 inch).  
 62. Lay a straight edge across the top of the two nuts. Check the height of the push rod to the bottom of the straight edge.  
 63. If the push rod is out of the limits specified adjust as follows.  
 64. Remove the push rod from the servo, clamp the small domed end of the rod in a bench vice and detach the main stem.  
 65. Remove the small spacer. Increase or decrease the size of the spacer accordingly until the correct dimension is attained.

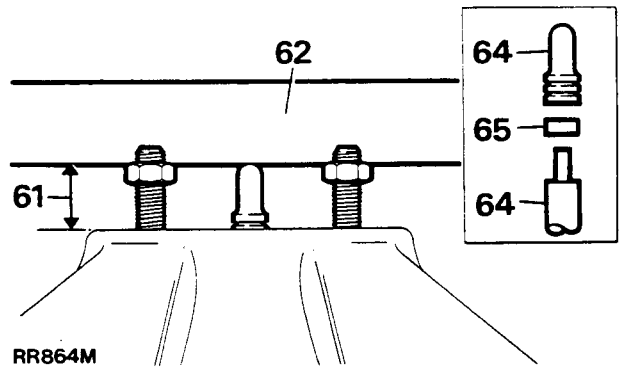

66. Coat the push rod seal with Lockheed disc brake lubricant and fit to the servo.  
 67. Carefully prise the non-return valve and seal out of the servo shell.  
 68. Fit new seal.  
 69. Inspect the non-return valve for condition, renew if necessary.  
 70. Fit non-return valve.  
 71. Install the servo into the vehicle and tighten all bolts to the correct torque see 'Data section'.  
 72. Reconnect the servo operating rod to the brake pedal with the pivot bolt eccentric in the forward position, do not fully tighten the pivot bolt nut.  
 73. Turn the pivot bolt to bring the brake pedal back until it just contacts the rubber then secure the pivot bolt nut.



FRONT BRAKE CALIPER ASSEMBLY

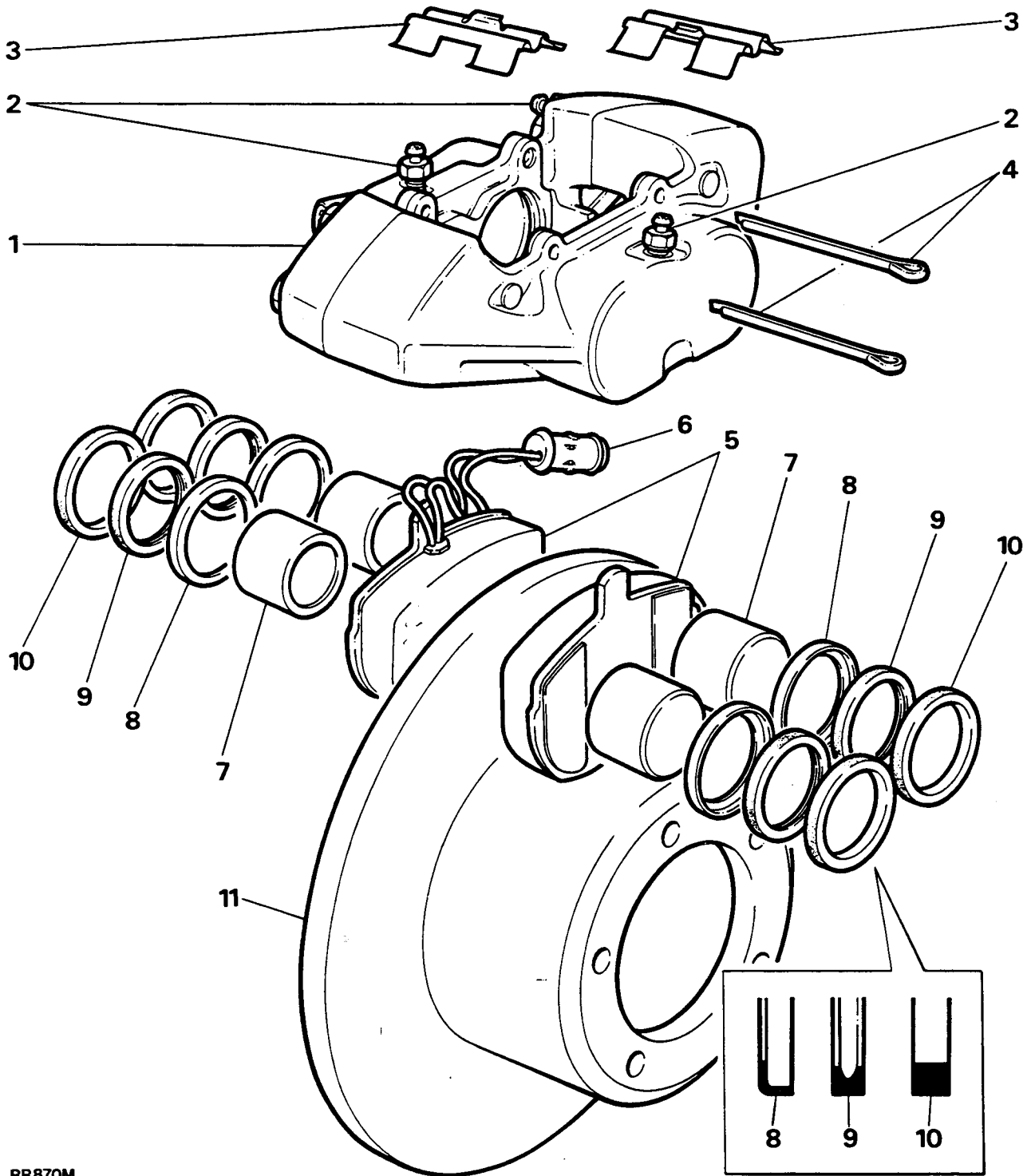

RR870M

KEY TO CALIPER

- |                            |                        |
|----------------------------|------------------------|
| 1. Caliper                 | 7. Piston              |
| 2. Bleedscrews             | 8. Wiper seal retainer |
| 3. Pad retaining springs   | 9. Wiper seal          |
| 4. Retaining pins          | 10. Fluid seal         |
| 5. Friction pads           | 11. Brake disc         |
| 6. Pad wear indicator plug |                        |

## REMOVE AND OVERHAUL FRONT BRAKE CALIPERS

Service tool:  
18G 672—Piston clamp

**NOTE:** Pad wear warning indicators are incorporated into the front right-hand inboard pad and the rear left hand inboard pad.

### Remove caliper

1. Slacken the front wheel retaining nuts, jack up the front of the vehicle and lower onto code stands and remove the wheels.
2. Expose the two flexible brake hoses by moving the coiled protective covering.
3. Clamp both hoses to prevent loss of brake fluid, and disconnect the hoses from the caliper.
4. Disconnect the pad wear warning indicator (front right-hand side only).
5. Remove the retaining pins and springs, withdraw the pads. If the same pads are to be refitted, identify them for assembly to their original locations.
6. Remove the two bolts and withdraw the caliper from the disc.

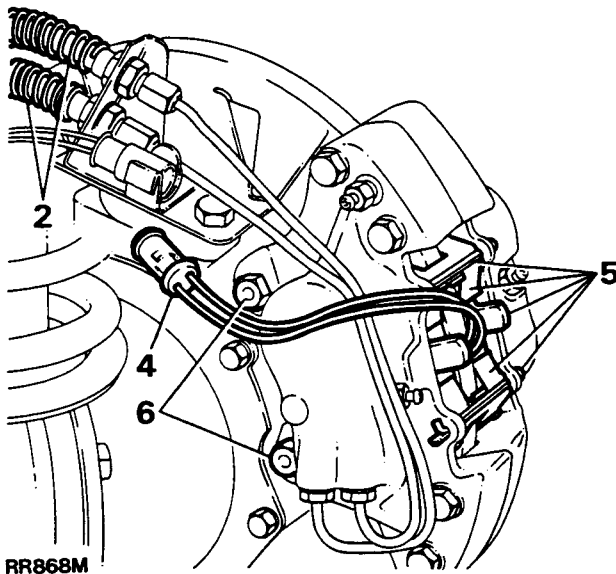

### DISMANTLE AND OVERHAUL

#### Do not separate the caliper halves

7. Clean the outer surfaces of the caliper with methylated spirit.
8. Using special tool 18G 672, clamp the pistons in the mounting half of the caliper and gently, keeping fingers clear, and with CAUTION, apply air pressure to the fluid inlet port to expel the rim half pistons. Since it is unlikely that both pistons will expel at the same time, regulate the rate with a suitable piece of timber between the appropriate piston and caliper.

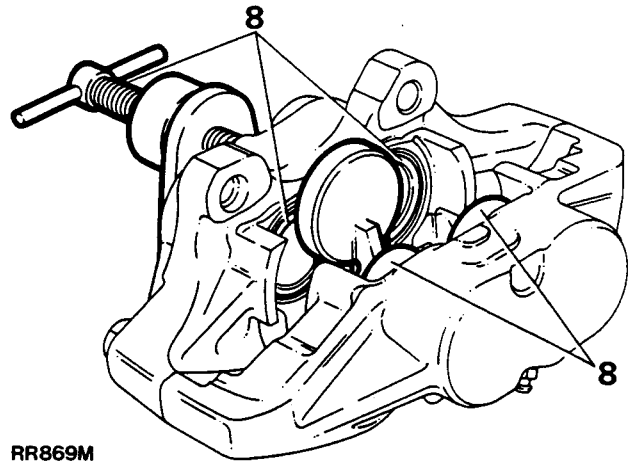

RR869M

9. Finally, remove the pistons keeping them identified with their respective bores.
10. Remove the wiper seal retainer by inserting a blunt screwdriver between the retainer and the seal and prise the retainer carefully from the mouth of the bore.
11. Taking care not to damage the seal grooves, extract the wiper seal and fluid seal.
12. Clean the bores, pistons and particularly the seal grooves with clean brake fluid or methylated spirit only. If the caliper or pistons are corroded or if their condition is not perfect the parts must be renewed.

### Assemble rim-half pistons

13. Coat a new fluid seal with Lockheed disc brake lubricant. Ease the seal into the groove in the bore using only the fingers and ensure that it is properly seated. The fluid seal and the groove are not the same in section so that when the seal is seated it feels proud to the touch at the edge furthest away from the mouth of the bore.
14. Smear the appropriate piston with disc brake lubricant and insert it squarely into the bore by hand only. Do not tilt the piston during insertion and leave approximately 8 mm projecting from the bore.
15. Coat a new wiper seal with disc brake lubricant and fit it to a new seal retainer. Slide the assembly, seal first, over the protruding piston and into the bore recess. Remove the piston clamp from the mounting half and use the clamp to press home the seal retainer and piston.

### Mounting rim-half pistons

16. Clamp the rim-half pistons and carry out the same procedure as for removing and fitting the rim-half pistons and seals, instructions 8 to 15.

### Fit calipers and pads to vehicle

17. Fit the caliper to the axle and secure with the two bolts tightening evenly to the correct torque, see data section.

18. Connect the brake flexible hose to the caliper and tighten to the correct torque, see data section.
19. Remove the clamps from the hoses.
20. Lightly smear the back and edges of the pads with disc brake lubricant carefully avoiding the friction material.
21. Insert the pads and retaining springs and secure with new pins and splay the ends. Note the correct position of the retaining springs.

**NOTE:** Ensure that the friction pad with the wear indicator is fitted to the inboard side of the front right-hand caliper.

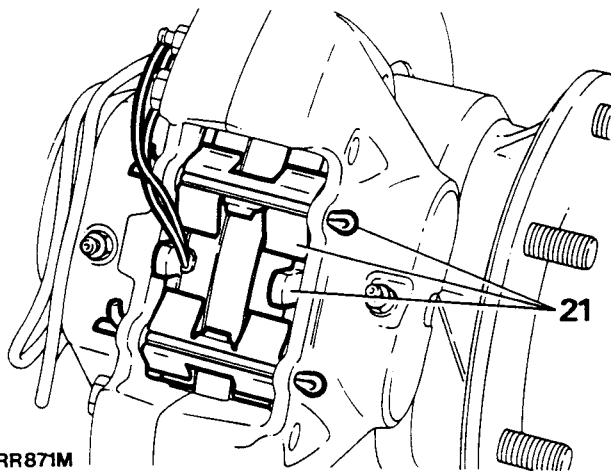

22. Reconnect the pad wear indicator electrical plug.
23. Bleed both the primary and secondary brake systems at the front calipers.
24. When the foregoing instructions have been completed on both calipers, depress the brake pedal firmly several times to locate the friction pads.
25. Fit the road wheels, remove the axle stands and finally tighten the road wheel nuts.
26. Road test the vehicle, remembering that if new friction pads have been fitted they are not 'bedded-in' and may take several hundred miles before the brakes are at maximum efficiency.

## REMOVE AND OVERHAUL REAR BRAKE CALIPERS

**Service tool:**  
18G 672—Piston clamp

### Remove caliper

1. Slacken the rear road wheel nuts and jack up the rear of the vehicle, and lower onto axle stands and remove the wheels.

2. Clamp the flexible brake hose above the rear axle, to prevent loss of fluid.
3. Remove the brake pipe from the rear brake caliper.
4. Disconnect the pad wear indicator (rear left-hand side only.).
5. Remove the retaining pins and springs and withdraw the pads. If the same pads are to be refitted, identify them for assembly to their original locations.
6. Remove the two bolts and withdraw the caliper from the axle.

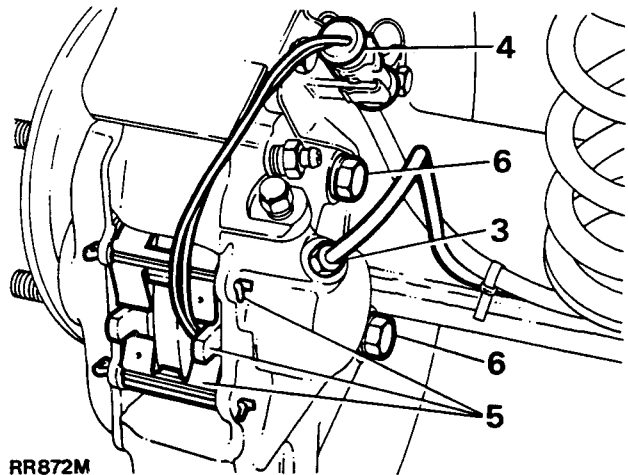

### Dismantle and overhaul

#### Do not separate the caliper halves

7. Clean the outer surfaces of the caliper with methylated spirit.
8. Expel the pistons from their bores by applying air pressure to the fluid inlet port. Since it is unlikely that both pistons will expel at the same time, regulate the rate with a suitable piece of timber inserted between the two pistons.

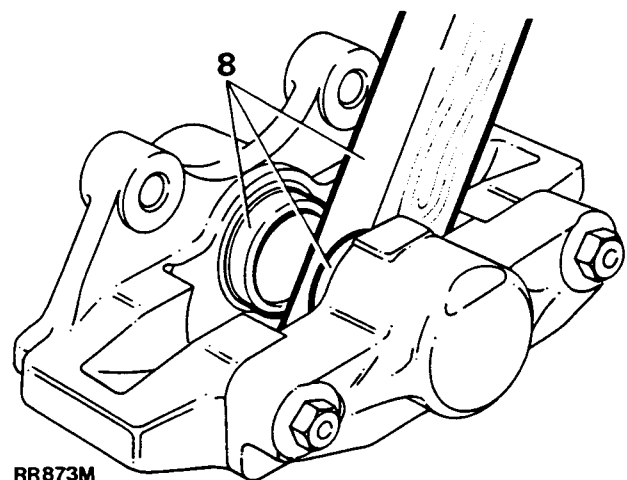

*Continued*

9. Finally, remove the pistons keeping them identified with their respective bores.
10. Remove the wiper seal retainer by inserting a blunt screwdriver between the retainer and the seal and prise the retainer carefully from the mouth of the bore.
11. Taking care not to damage the seal grooves, extract the wiper seal and fluid seal.
12. Clean the bores, pistons and particularly the seal grooves with clean brake fluid or methylated spirit only. If the caliper or pistons are corroded or if their condition is not perfect the parts must be renewed.

**Assemble rim-half piston**

13. Coat a new fluid seal with Lockheed disc brake lubricant. Ease the seal into the groove in the bore using only the fingers and ensure that it is properly seated. The fluid seal and the groove are not the same in section so that when the seal is seated it feels proud to the touch at the edge furthest away from the mouth of the bore.

*Continued*

**REAR BRAKE CALIPER ASSEMBLY**

LH Rear Caliper illustrated

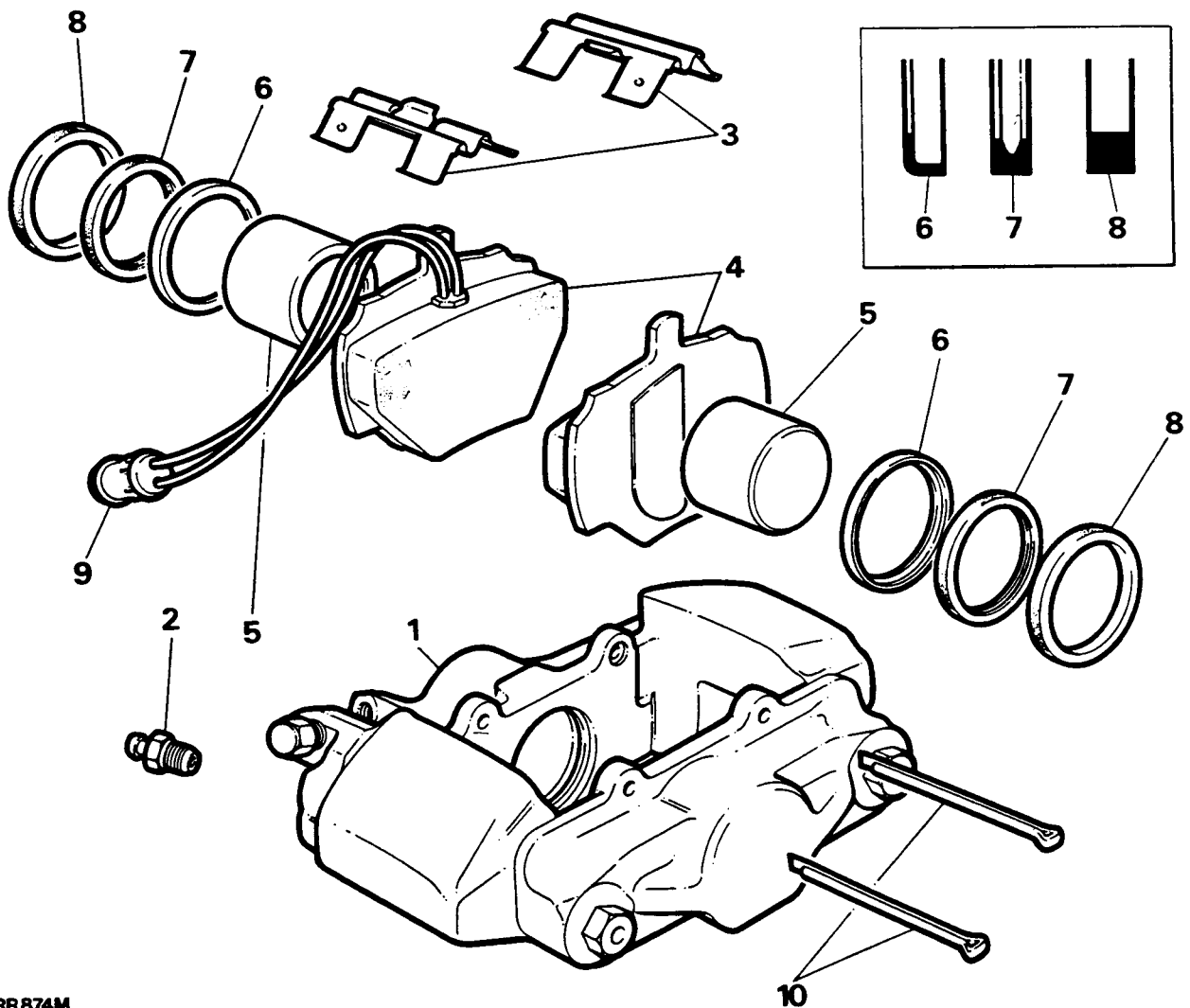

RR874M

**KEY TO CALIPER**

- |                           |                             |
|---------------------------|-----------------------------|
| 1. Caliper.               | 6. Wiper seal retainer.     |
| 2. Bleed screw.           | 7. Wiper seal.              |
| 3. Pad retaining springs. | 8. Fluid seal.              |
| 4. Friction pads.         | 9. Pad wear indicator plug. |
| 5. Piston.                | 10. Retaining pins.         |

14. Smear the appropriate piston with disc brake lubricant and insert it squarely into the bore by hand only. Do not tilt the piston during insertion and leave approximately 8 mm projecting from the bore.
15. Coat a new wiper seal with disc brake lubricant and fit it to a new seal retainer. Slide the assembly, seal first, over the protruding piston and into the bore recess.
16. Using special tool 18G 672—piston clamp, press home the seal retainer and piston.

#### Mounting rim-half piston

17. Carry out the same procedure as for removing and fitting the rim-half piston and seals, instructions 8 to 16.

#### Fit calipers and pads to vehicle

18. Fit the caliper to the axle and secure with the two bolts tightening evenly to the correct torque, see 'Data section'.
19. Connect the brake pipes to the calipers and remove the clamp from the flexible brake hose above the rear axles, see 'Data section' for brake pipe to caliper tightening torque.
20. Lightly smear the back and edges of the pads with disc brake lubricant carefully avoiding the friction material.
21. Insert the pads and retaining springs and secure with new pins and splay the ends. Note the correct position of the retaining springs.

**NOTE:** Ensure that the friction pad with the wear indicator is fitted to the inboard side of the rear left-hand brake caliper.

22. Reconnect the pad wear indicator electrical multi-plug.

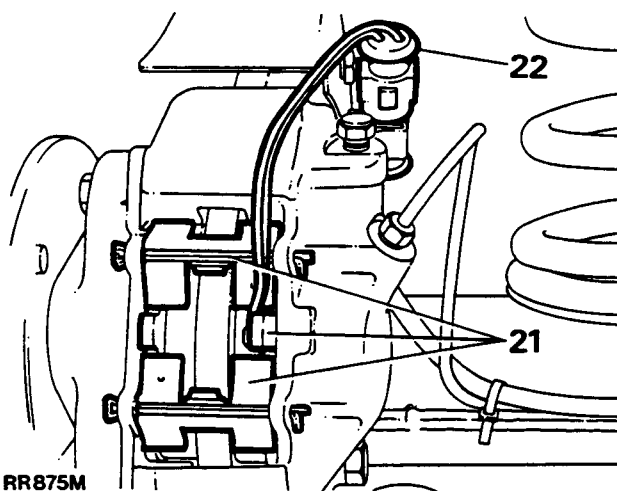

23. Bleed the secondary brake system at the rear calipers, starting at the caliper furthest away from the master cylinder.

24. When the foregoing instructions have been completed on both calipers, depress the brake pedal firmly several times to locate the friction pads.
25. Fit the road wheels, remove the axle stands and finally tighten the road wheel nuts, see data.
26. Road test the vehicle, remembering that if new friction pads have been fitted they are not 'bedded-in' and may take several hundred miles before the brakes are at maximum efficiency.

#### TRANSMISSION BRAKE LEVER (HANDBRAKE)

##### Remove and refit

##### Removing

1. Disconnect the battery.
2. Chock the road wheels and release the handbrake.
3. Open the cubby box lid and remove the four screws securing the cubby box liner to the outer surround and lift out the liner.
4. Remove the two electrical leads at the rear of the cubby box cigar lighter and release the two heater hoses from their retaining clips.
5. Remove the five electrical multi-plugs from the rear of the window lift switch panel, noting their position for re-assembly.
6. Remove the main gear selector knob and transfer gearbox knob.
7. Carefully prise the centre panel out of the gearbox tunnel mounted console.

**NOTE:** On Automatic gearbox models it is necessary to remove the two selector panel illumination bulbs from the graphics panel.

8. Remove the four bolts and plain washers, two are located immediately behind the handbrake lever accessible from inside the cubby box. The remaining two bolts are located forward of the handbrake lever accessible from the floor mounted console aperture.

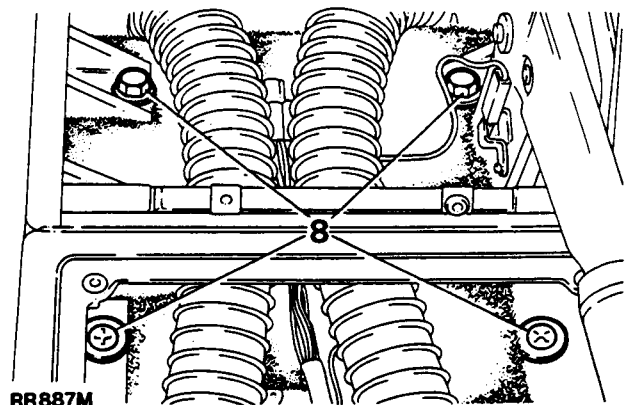

*Continued*

9. Ease the cubby box and console assembly rearwards to release the location tab from the radio housing and lift the assembly off the gearbox tunnel.
10. Release the split pin and remove the clevis pin, plain and thackeray washer securing the handbrake cable to the lever.
11. Disconnect the electrical lead from the hand brake warning switch.
12. Release the handbrake cable outer retaining nut.
13. Remove the remaining single bolt with plain washer securing the front of the handbrake mounting bracket.
14. Withdraw the handbrake assembly and remove the cable outer.

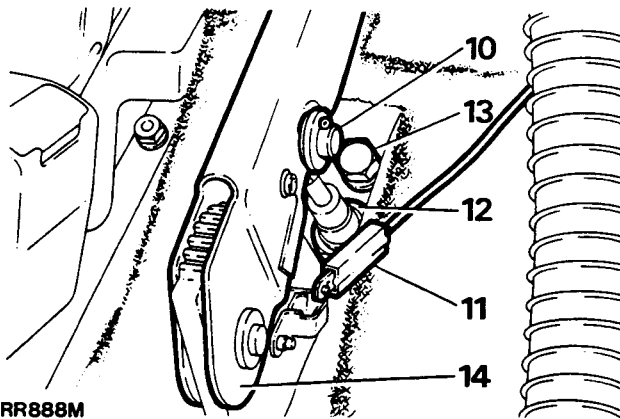

RR888M

**Refitting**

15. Attach the cable outer to the handbrake mounting bracket and tighten the retaining nut securely.
16. Fit the assembly to the gearbox tunnel, lightly secure in position with the front retaining bolt.
17. Fit the inner cable to the handbrake assembly, secure in position with a new split pin.
18. Fit the cubby box console assembly, securing in position with the two screws, two bolts with plain washers.
19. Tighten the two handbrake securing bolts.
20. Reverse the remaining removal instructions, ensuring that the electrical wiring in the cubby box assembly is arranged to prevent it becoming trapped between any mating faces.

**OVERHAUL TRANSMISSION BRAKE**

**WARNING:** Do not use an air line to remove dust from the brake assembly. Asbestos dust from the brake linings can be a serious health risk, if inhaled.

**DISMANTLING**

1. Disconnect the battery and chock the road wheels for safety.
2. Disconnect the propeller shaft from the output flange.
3. Remove the two screws and withdraw the brake drum. Skim if excessively scored or oval.
4. Remove the split pin and clevis pin connecting the drawlink to the actuating lever.
5. Remove the brake shoes complete with pull-off springs. Note position of springs in relation to the shoes.
6. Remove the four bolts securing back plate to transfer box and withdraw the back plate complete with oil catcher.

**Remove and overhaul expander assembly**

7. Remove the rubber dust cover.
8. Remove the expander and draw link.
9. Remove the retainer spring plate.
10. Remove the locking plate.
11. Remove the packing plate and withdraw the expander assembly from the back plate.
12. Remove the two plungers and rollers.

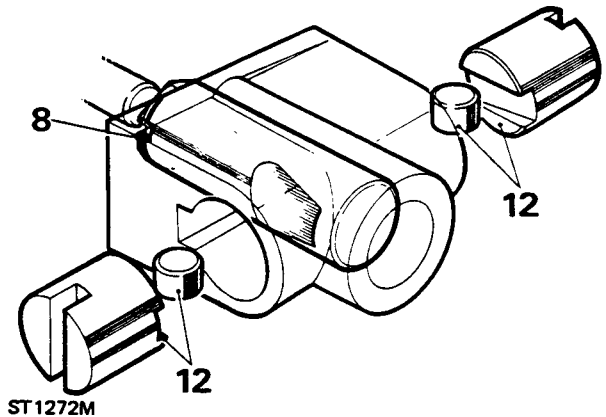

ST1272M

13. Clean all parts in Girling cleaning fluid and allow to dry. Examine the components for wear and discard if unsatisfactory.

**Assemble expander assembly**

14. Grease and fit the expander and drawlink.
15. Grease and fit the plungers and rollers noting that the highest end of the ramp on the plungers is fitted towards the back plate. Secure the assembly with a rubber band to prevent the plungers falling out and place to one side for assembly to back plate.

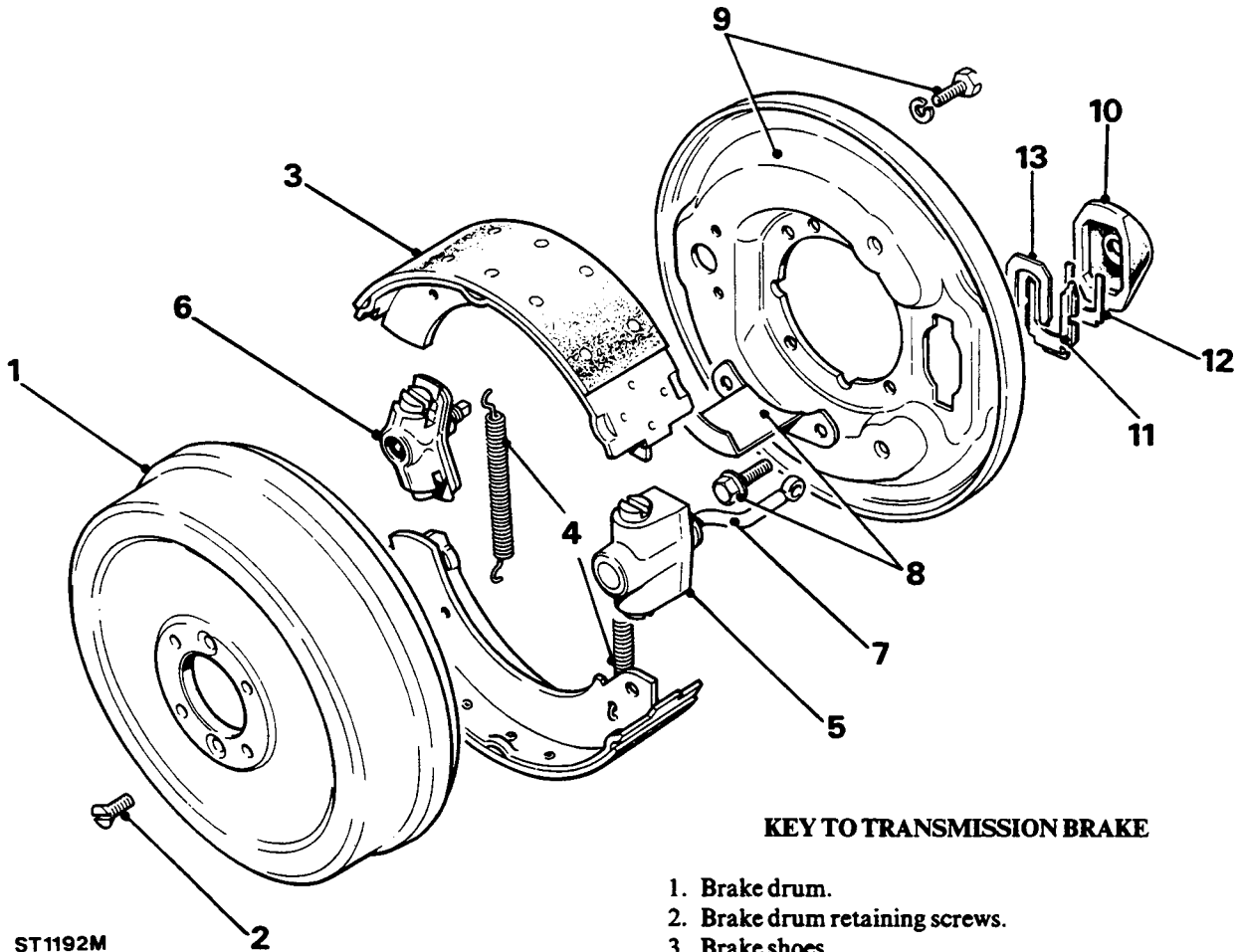

**KEY TO TRANSMISSION BRAKE**

- 1. Brake drum.
- 2. Brake drum retaining screws.
- 3. Brake shoes.
- 4. Brake shoes pull-off springs.
- 5. Expander assembly.
- 6. Adjuster assembly.
- 7. Draw link.
- 8. Oil catcher.
- 9. Back plate and retaining bolts.
- 10. Dust cover.
- 11. Locking plate.
- 12. Packing plate.
- 13. Spring plate.

**Remove and overhaul adjuster assembly**

- 16. Remove the two bolts and withdraw the adjuster assembly from the back plate.
- 17. Remove the plungers.
- 18. Screw the adjuster cone inwards to remove from the housing.
- 19. Clean the parts in Girling cleaning fluid and discard any unsatisfactory components.

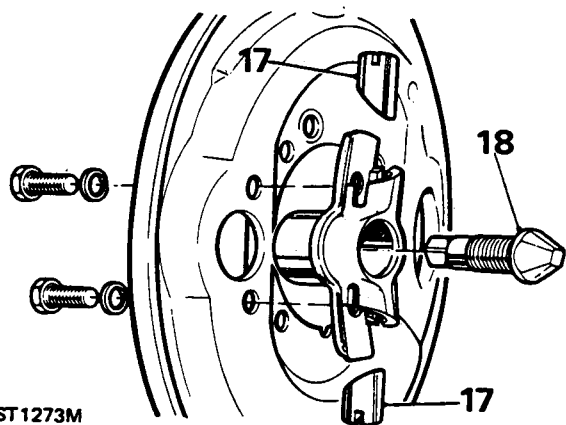

**Assemble adjuster assembly**

- 20. Grease and screw in the adjuster cone.
- 21. Grease and fit the adjuster plungers and align the chamfered ends with the adjuster cone. Note that the two plungers are identical and can be fitted to either bore. Secure the assembly with a rubber band to prevent the plungers falling out.

*Continued*

**ASSEMBLE**

**NOTE:** If the brake linings are oil-soaked check and if necessary renew the output shaft oil seal.

- 22. Position the expander assembly on the inside of the back plate and secure with the following plates at the rear of the back plate.
- 23. Packing piece.
- 24. Locking plate.
- 25. Retainer spring.
- 26. Fit the rubber dust cover.

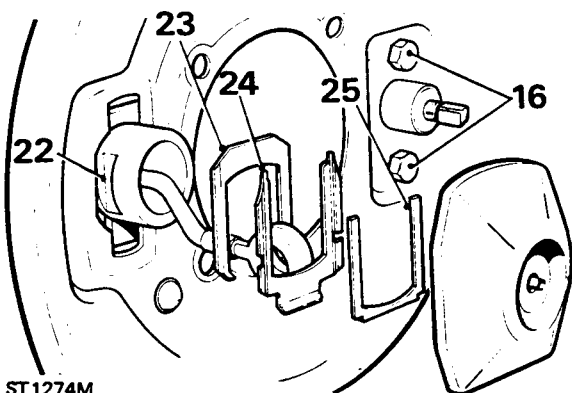

- 27. Fit the adjuster assembly to the back plate with the two bolts but do not fully tighten at this stage.
- 28. Fit the back plate assembly and mud shield to the transfer box with the four bolts and tighten to the correct torque.
- 29. Fit new pull-off springs to relined brake shoes and fit to the back plate. Note that the fully lined end of the lower shoe must be toward the expander assembly and the fully lined end of the upper shoe towards the adjuster assembly.

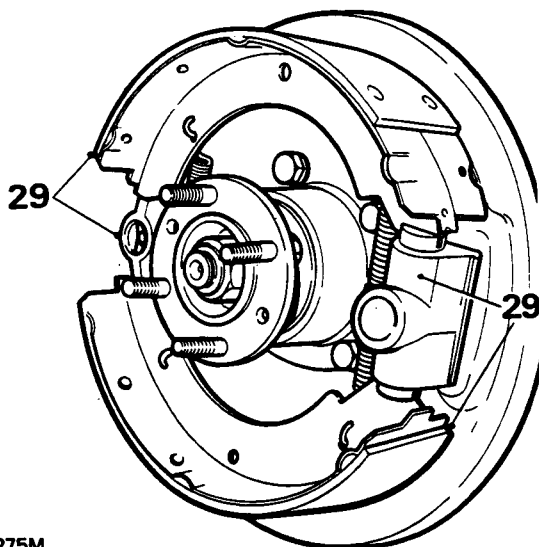

- 30. Fit the brake drum and secure with the two screws.
- 31. Connect the expander drawlink to the actuating lever with a new clevis pin, washer and split pin.
- 32. Turn the adjuster cone fully in and tighten the two retaining bolts left slack in instruction 27.
- 33. Slacken off the adjuster two 'clicks' and firmly apply the hand lever to centralise the shoes. The drum should then rotate freely.
- 34. Adjust the handbrake cable to give the pawl two 'clicks' free movement on the ratchet before the third 'click' fully expands the shoes against the drum.
- 35. Connect the propeller shaft and evenly tighten the retaining nuts to the correct torque.
- 36. Remove chocks from wheels and connect the battery.

**TRANSMISSION BRAKE CABLE (HANDBRAKE)**

**Remove and refit**

**Removing**

- 1. Set the vehicle on level ground and chock the wheels.
- 2. Release the handbrake.

**From inside the vehicle**

- 3. Remove the two screws securing the liner in the cubby box.
- 4. Lift out the liner to gain access to the bottom of the handbrake pivot bracket.
- 5. Remove the split pin and clevis pin from the handbrake lever.
- 6. Release the nut securing the handbrake outer cable to the top of the tunnel. Slide the nut up the cable and push the inner and outer cable through the floor panel to the underside of the vehicle.

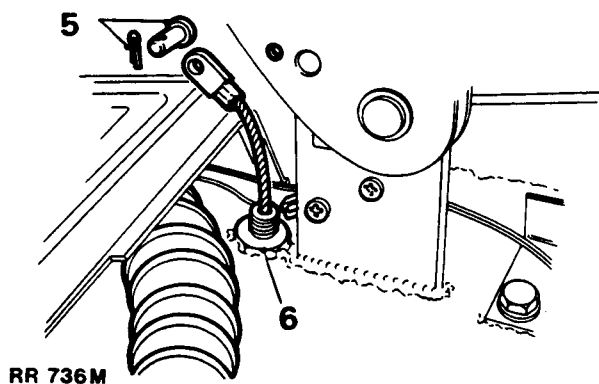



**From underneath the vehicle**

7. Remove the split pin, plain and thackery washer and clevis pin securing the adjustment link to the brake drum actuating lever.
8. Remove the four bolts with spring washers securing the handbrake linkage assembly to the side of the transfer gearbox.
9. Withdraw the linkage from beneath the vehicle complete, with handbrake cable attached.
10. Remove the split pin, plain and thackery washer securing the cable to the handbrake linkage.
11. Withdraw the clevis pin.
12. Release the locknuts securing the handbrake outer cable to the retaining bracket.
13. Remove the cable from the bracket.

22. Refit the clevis pin, washers and split pin.
23. Apply the handbrake, and slacken the brake drum adjuster until the handbrake lever fully operates the brake shoes on the third or fourth handbrake quadrant notch.

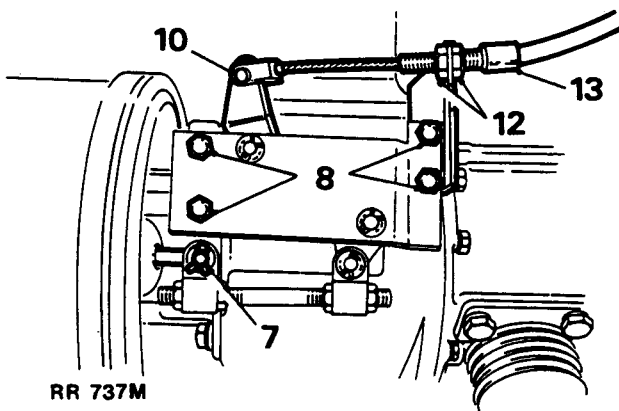
**Fit new cable**

14. Feed the handbrake cable through the floor aperture and secure the outer cable in position with the retaining nut.
15. Secure the cable to the handbrake lever, using a new split pin.
16. Fit the other end of the cable to the handbrake linkage using a new split pin.
17. Secure the outer cable to the retaining bracket and lightly tighten the two locknuts.

**NOTE:** To ensure that adjustment is not exhausted on the adjustment link, initial handbrake setting should be taken up at the outer cable locknuts.

18. Apply the handbrake, the brake shoes should make contact with the drum on the first notch of the handbrake quadrant. Adjust the locknuts on the outer cable as necessary. Release the handbrake.
19. Refit the handbrake linkage assembly to the side of the transfer box, tighten the bolts to the specified torque, see 'data' section.
20. Rotate the brake drum adjuster clockwise until the shoes are fully expanded against the drum.
21. Release the four locknuts at the adjustment link, rotate the link until the clevis pin holes in the adjustment link and brake drum actuating lever line up.

