

RANGE ROVER
1989 MODEL YEAR
WORKSHOP MANUAL SUPPLEMENT
Publication number LSM 180 WS3

Published by the
Technical Publications Department of



Land Rover Ltd

A Managing Agent for Land Rover (UK) Limited
© Copyright Land Rover 1988

CONTENTS

Section Number	Page
01	INTRODUCTION
Introduction	1
Used engine oil handling precaution	2
Disposing of used engine oil	2
Identification number - Borg Warner transfer gearbox	2
04	GENERAL SPECIFICATION DATA
Transfer and main gearbox ratios	1
Automatic shift speed specification	2
06	TORQUE WRENCH SETTINGS
Transfer gearbox	1
LT77 Five speed manual gearbox	1
Seat belt fixings	1
09	LUBRICANTS, FLUIDS AND CAPACITIES
Chart - Recommended lubricants	1
Chart - Oil specification	2
Transfer gearbox capacity	2
10	MAINTENANCE
Top up transfer gearbox oil	1
Renew transfer gearbox oil	1
Adjust handbrake	2
Rolling road testing	3
Towing	3
37	BORG WARNER TRANSFER GEARBOX
Viscous unit - In vehicle check	1
In - situ operations	
- Renew speedometer drive pinion	1
- Renew rear output shaft oil seal	1
- Renew front output shaft oil seal	2
Transfer gearbox adaptor plate	3
Transfer gearbox - Remove and refit	7
- Dismantle and overhaul	11
37	LT77 FIVE SPEED GEARBOX
Main and transfer gearbox adaptor plate	29
Main and transfer gearbox - remove and refit	31
LT77 main gearbox - Dismantle and overhaul	34

44 AUTOMATIC GEARBOX

Main and transfer gearbox adaptor plate	1
Main and transfer gearbox - Remove and refit	3

70 BRAKES

Handbrake cable - Remove and refit	1
- Adjust	1

76 BODY

Front door interior trim panel - 4 door models	1
Front door lock and door release handles - 4 door models	2
Front door lock and door release handles - adjustment - 4 door models	3
Rear door interior trim panel - 4 door models	4
Rear door lock and door release handles - 4 door models	5
Rear door lock and door release handles - adjustment - 4 door models	6
Asymmetric split rear seat locking mechanism	7

82 AIR CONDITIONING

Circuit diagram	1
-----------------	---

84 WIPERS AND WASHERS

Heated washer jets - remove and refit	1
Heated washer jets - thermostat - remove and refit	2

86 ELECTRICAL

Fuses	1
Relays - identification	2
Central locking tailgate actuator - remove and refit	5
Circuit diagrams	
- Central door locking	6
- Electric seat adjustment	7
- Electric window lift	8
- Main circuit diagram - right hand steering vehicles	10
- Main circuit diagram - left hand steering non catalyst vehicles	14

INTRODUCTION - 1989 MODEL YEAR

A number of model improvements are introduced on all Range Rover models for the 1989 Model Year.

Specifications for individual vehicles may vary, but all will include some of the new features and options summarised below.

- Borg Warner transfer gearbox incorporating viscous coupling
- Revised LT77 five speed manual gearbox
- Revised handbrake linkage
- Rear asymmetric seat locking mechanism
- Interior door trim panels
- Central locking on upper tailgate
- Revised heater distribution and controls
- Single touch electric window lift (Drivers door only)
- Heated screen washer jets
- Variable delay windscreen wipers
- Ignition override of headlamps

Service and repair information is included in this supplement, which should be used in conjunction with the main Range Rover Workshop Manual.

This Workshop Manual Supplement is designed to assist skilled technicians in the efficient repair and maintenance of Range Rover vehicles.

Individuals who undertake their own repairs should have some skill and training, and limit repairs to components which could not affect the safety of the vehicle or its passengers. Any repairs required to safety critical items such as steering, brakes, or suspension should be carried out by a Range Rover Dealer. Repairs to such items should NEVER be attempted by untrained individuals.

Continued

01 INTRODUCTION

ENGINE OIL HANDLING PRECAUTIONS

Prolonged and repeated contact with mineral oil will result in the removal of natural fats from the skin, leading to dryness, irritation and dermatitis. In addition, used engine oil contains potentially harmful contaminants which may cause skin cancer. Adequate means of skin protection and washing facilities should be provided.

WARNING:

1. Avoid prolonged and repeated contact with oils, particularly used engine oils.
2. Wear protective clothing, including impervious gloves where practicable.
3. Do not put oily rags in pockets.
4. Avoid contaminating clothes, particularly underwear, with oil.
5. Overalls must be cleaned regularly. Discard unwashable clothing and oil impregnated footwear.
6. First aid treatment must be obtained immediately for open cuts and wounds.
7. Use barrier creams, before each work period, to help the removal of oil from the skin.
8. Wash with soap and water to ensure all oil is removed (skin cleansers and nail brushes will help). Preparations containing lanolin replace the natural skin oils which have been removed.
9. Do not use petrol, kerosene, diesel fuel, gas oil, thinners or solvents for washing the skin.
10. If skin disorders develop, obtain medical advice as soon as possible.
11. Where practicable, degrease components prior to handling.
12. Where there is a risk of eye contact, eye protection must always be worn, for example, goggles or face shields; in addition an eye wash facility should be provided.

DISPOSING OF USED OILS

Environmental protection precautions

It is illegal to pour used oil on to the ground, down sewers or drains, or into water courses.

The burning of used engine oil in small space heaters or boilers is not recommended unless emission control equipment is fitted.

Dispose of used oil through authorised waste disposal contractors to licensed waste disposal sites, or to the waste oil reclamation trade. If in doubt, contact the Local Authority for advice on disposal facilities.

TRANSFER GEARBOX - BORG WARNER - 1989 MODEL YEAR

The gearbox serial number is stamped on a plate which is attached to the gearbox casing and is located between the filler/level and drain plugs adjacent to the rear output housing.

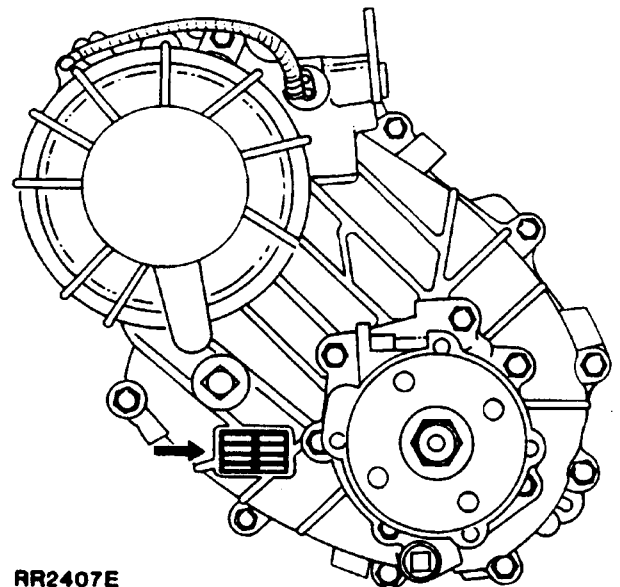

RR2407E

TRANSMISSION

Borg Warner transfer gearbox

Type Two speed reduction on main gearbox output, front and rear drive permanently engaged via a centre differential controlled by a Viscous unit giving a 50/50 nominal front and rear torque split.

Transfer gearbox ratios

High 1.206:1
 Low 3.244:1

Automatic gearbox ratios

4th 0.728:1
 3rd 1.000:1
 2nd 1.480:1
 1st 2.480:1
 Reverse 2.086:1

Overall ratios (final drive):	High transfer	Low transfer
4th	3.11:1	8.36:1
3rd	4.27:1	11.48:1
2nd	6.32:1	17.00:1
1st	10.59:1	28.50:1
Reverse	8.91:1	23.96:1

Manual gearbox LT77 ratios

5th 0.770:1
 4th 1.000:1
 3rd 1.397:1
 2nd 2.132:1
 1st 3.321:1
 Reverse 3.429:1

Diesel models - low 1st gear 3.692:1

Overall ratios (final drive):	High transfer	Low transfer
5th	3.29:1	8.84:1
4th	4.27:1	11.48:1
3rd	5.97:1	16.04:1
2nd	9.10:1	24.48:1
1st	14.18:1	38.14:1
Reverse	14.64:1	39.38:1
Diesel models - low 1st gear	15.76:1	42.40:1

04 GENERAL SPECIFICATION

SHIFT SPEED SPECIFICATION Automatic ZF4HP22 Gearbox

OPERATION	SELECTOR POSITION	VEHICLE SPEED APPROX		ENGINE SPEED APPROX (RPM)
KICKDOWN				
		MPH	KPH	
KD4 - 3	D	79 - 96	127 - 155	
KD3 - 2	3(D)	57 - 62	91 - 99	
KD2 - 1	2(D,3)	27 - 34	44 - 56	
KD3 - 4	D	N/A	N/A	
KD2 - 3	D(3)	60 - 63	96 - 104	4750 - 5200
KD1 - 2	D(3,2)	34 - 40	56 - 64	4600 - 5250
FULL THROTTLE				
FT4 - 3	D	61 - 67	98 - 108	
FT3 - 2	3(D)	40 - 46	64 - 73	
FT3 - 4	D	74 - 80	119 - 129	3980 - 4330
FT2 - 3	D(3)	55 - 60	88 - 96	4350 - 4800
FT1 - 2	D(3,2)	29 - 34	48 - 56	3950 - 4650
PART THROTTLE				
PT4 - 3	D	47 - 54	75 - 86	
PT3 - 2	D(3)	29 - 37	48 - 59	
PT2 - 1	D(3,2)	10 - 12	16 - 19	
LIGHT THROTTLE				
LT3 - 4	D	26 - 30	43 - 49	1430 - 1650
LT2 - 3	D(3)	18 - 22	29 - 35	1420 - 1820
LT1 - 2	D(3,2)	9 - 10	14 - 16	1180 - 1220
ZERO THROTTLE				
ZT4 - 3	D	19 - 25	31 - 41	
ZT3 - 2	D(3)	12 - 15	19 - 24	
ZT2 - 1	D(3,2)	6 - 7	10 - 11	
TORQUE CONVERTER				
Lock up (IN)	D	51 - 54	81 - 86	1875 - 2000
Unlock (OUT)	D	49 - 52	78 - 83	1825 - 1930

NOTE: The speeds given in the above chart are approximate and only intended as a guide. Maximum shift changes should take place within these tolerance parameters.

BORG WARNER TRANSFER GEARBOX

	Nm	lb ft	lb in
Brake drum back plate to rear output housing	65 - 80	48 - 59	-
Brake drum to drive flange	22 - 28	16 - 21	-
Centre differential (front to rear)	55 - 64	40 - 47	-
Drive flanges to transfer gearbox	203 - 244	150 - 180	-
Driven gear to centre differential	41 - 61	30 - 45	-
Front cover to rear cover - main case	30 - 49	22 - 36	-
Front output housing to main case	24 - 41	18 - 30	-
Gearbox mounting brackets to chassis	40 - 50	29 - 37	-
Mounting bracket to gearbox	92 - 112	68 - 83	-
Neutral warning switch	34 - 47	25 - 35	-
Oil drain plug	19 - 30	14 - 22	-
Oil filler/level plug	19 - 30	14 - 22	-
Oil pump fixings	4 - 8.5	-	35 - 75
Propeller shafts to drive flanges	41 - 52	30 - 38	-
Rear output housing to main case	30 - 49	22 - 36	-
Selector lever shaft - Torx screw	7 - 9	5 - 7	60 - 84
Selector fork operating arm - Torx screw	7 - 9	5 - 7	60 - 84

LT77 MAIN GEARBOX (FIVE - SPEED)

	Nm	lb ft.
Bottom cover to clutch housing	7 - 10	5 - 7
Oil pump body to extension case	7 - 10	5 - 7
Clip to clutch release lever	7 - 10	5 - 7
Attachment plate to gearcase	7 - 10	5 - 7
Extension case to gearcase	22 - 28	16 - 21
Pivot - clutch lever to bell housing	22 - 28	16 - 21
Guide clutch release sleeve	22 - 28	16 - 21
Slave cylinder to clutch housing	22 - 28	16 - 21
Front cover to gearcase	22 - 28	16 - 21
5th support bracket	22 - 28	16 - 21
Clutch housing to gearbox	65 - 80	48 - 59
Oil drain plug	40 - 47	30 - 35
Oil filter plug	65 - 80	48 - 59
Breather	14 - 16	10 - 12
Oil level plug	25 - 35	19 - 26
Upper gear lever to lower gear lever	22 - 28	16 - 21
Upper gear lever to lower gear lever - pinch bolt	22 - 28	16 - 21
5th layshaft gear retaining nut	204 - 231	150 - 170
Attachment plate to gear change housing	7 - 10	5 - 7
Gear change housing to extension case	22 - 28	16 - 21
Plunger housing to gear change housing	22 - 28	16 - 21
Adjustment plate to gear change housing	22 - 28	16 - 21
Cover to gear change housing	7 - 10	5 - 7
Bell housing to cylinder block bolts	36 - 45	27 - 33
Yoke to selector shaft	22 - 28	16 - 21

SEAT BELT FIXINGS

	Nm	lb ft
Front and rear seat belt fixings (all)	20.3	15

Recommended Lubricants and fluids - 1989 Model year

Use only the recommended grades of oil set out below.

These recommendations apply to climates where operational temperatures are above - 10°C (14°F)

COMPONENTS	BP	CASTROL	DUCKHAM	ESSO	MOBIL	PETROFINA	SHELL	TEXACO
Petrol engine sump Carburetter Dashpots Oil can	BP Visco 2000 (15W/40) or BP Visco Nova (10W/40)	Castrol GTX (15W/50) or Castrolite (10W/40)	Duckhams 15W/50 Hypergrade Motor Oil	Esso Superlube plus (15W/40)	Mobil Super (10W/40) or Mobil 1 Rally Formula	Fina Supergrade Motor Oil (15W/40) or (10W/40)	Shell Super Motor Oil (15W/40) or (10W/40)	Havoline Motor Oil (15W/40) or Eurotex HD (10W/30)
Diesel engine sump	BP Vanellus C3 Extra (15W/40)	Castrol Turbomax (15W/40)	Duckhams Fleetmaster SHPD (15W/40)	Esso Super Diesel Oil TD (15W/40)	Mobil Delvac 1400 Super (15W/40)	Fina Kappa LDO (15W/40)	Shell Myrina (15W/40)	Texaco URSA Super TD (15W/40)
The following list of oils to MIL - L - 2104D or CCMC D2 or API Service levels CD or SE/CD are for emergency use only if the above oils are not available. They can be used for topping up without detriment, but if used for engine oil changing, they are limited to a maximum of 5,000 km (3,000 miles) between oil and filter changes.								
	BP Vanellus C3 Multigrade (15W/40)	Castrol Deusol RX Super (15W/40)	Duckhams Hypergrade (15W/50)	Esso Essolube XD - 3 plus (15W/40)	Mobil Delvac Super (15W/40)	Fina Dilano HPD (15W/40)	Shell Rimula X (15W/40)	Texaco URSA Super Plus (15W/40)
Automatic gearbox	BP Autran DX2D	Castrol TQ Dexron IID	Duckhams Fleetmatic CD or Duckhams D - Matic	Esso ATF Dexron IID	Mobil ATF 220D	Fina Dexron IID	Shell ATF Dexron IID	Texamatic Fluid 9226
Manual gearbox	BP Autran G	Castrol TQF	Duckhams Q - Matic	Esso ATF Type G	Mobil ATF 210	Fina Purfimatic 33G	Shell Donax TF	Texamatic Type G or Universal
Front and Rear differential Swivel pin housings and LT230 Transfer gear box	BP Gear Oil SAE 90EP	Castrol Hypoy SAE 90EP	Duckhams Hypoid 90	Esso Gear Oil GX (85W/90)	Mobil Mobilube HD90	Fina Pontonic MP SAE (80W/90)	Shell Spirax 90EP	Texaco Multigear Lubricant EP (85W/90)
Propeller shaft Front and Rear	BP Energrease L2	Castrol LM Grease	Duckhams LB 10	Esso Multi - purpose Grease H	Mobil Grease MP	Fina Marson HTL 2	Shell Retinax A	Marfak All Purpose Grease
Power steering box and fluid Reservoir Borg Warner Transfer Gearbox	BP Autran DX2D or BP Autran G	Castrol TQ Dexron IID or Castrol TQF	Duckhams Fleetmatic CD or Duckhams Q - matic	Esso ATF Dexron IID or Esso ATF Type G	Mobil ATF 220D or Mobil ATF 210	Fina Dexron IID or Fina purifimatic 33G	Shell ATF Dexron IID or Shell Donax TF	Texamatic Fluid 9226 or Texamatic Type G or 4291A Universal
Brake and clutch reservoirs	Brake fluids having a minimum boiling point of 260°C (500°F) and complying with FMVSS 116 DOT4							
Lubrication nipples (hubs, ball joints etc.)	BP Energrease L2	Castrol LM Grease	Duckhams LB 10	Esso Multi - purpose Grease H	Mobil Grease MP	Fina Marson HTL 2	Shell Retinax A	Marfak All Purpose Grease
Ball joint assembly Top Link	Dextragrease Super GP							
Seat slides Door lock striker	BP Energrease L2	Castrol LM Grease	Duckhams LB 10	Esso Multi - purpose Grease H	Mobil Grease MP	Fina Marson HTL 2	Shell Retinax A	Marfak All purpose grease
	NLGI - 2 Multi - purpose Lithium - based Grease							

**** Other approved oils include:** Agip Sigma Turbo, Aral OL P327, Autol Valve - SHP, Aviation Turbo, Caltex RPM Delo 450, Century SHPD, Chevron Delo 450 Multigrade, Divinol Multimax Extra, Ecubsol CD Plus, Elf Multiperformance, Esso Special Diesel, Fanal Indol X, Fuchs Titan Truck 1540, Gulf Superfleet Special, IP Taurus M, Total Rubia TIR, Valvoline Super HD LD.

Check/top up transfer gearbox oil every - 6,000 miles (10,000 Km)
 Renew transfer gearbox oil every - 24,000 miles (40,000 Km)

TOP UP TRANSFER GEARBOX OIL
 - Borg Warner gearbox

NOTE: The existing maintenance intervals for the LT230 are also applicable to the Borg Warner transfer gearbox.

1. Before topping up the oil ensure that the vehicle is level, either on a hoist or on the ground.
2. Disconnect the battery negative terminal.
3. Clean the immediate area around the filler/level plug.
4. Remove the plug and fill the gearbox with the recommended grade of oil, until oil starts to seep from the filler/level hole.
5. Clean any previously applied sealant from the filler/level plug.
6. Apply Hylomar sealant to the threads of the plug and refit the plug. Tighten to the specified torque.

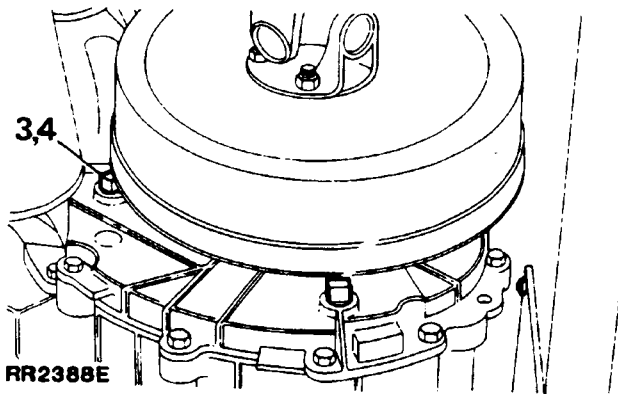

7. Wipe away any surplus oil.
8. Reconnect the battery.

RENEW TRANSFER GEARBOX OIL
 - Borg Warner gearbox

NOTE: The existing maintenance intervals for the LT230 are also applicable to the Borg Warner transfer gearbox.

1. Before renewing the oil ensure that the vehicle is level, either on a hoist or on the ground.
2. Disconnect the battery negative terminal.
3. Clean the immediate area around the filler/level and drain plugs.

WARNING: When draining the gearbox care should be taken to ensure that the oil is not hot as personal scalding could result.

4. Place a container under the gearbox to drain the oil into.
5. Remove the filler/level plug to vent the gearbox and assist draining.
6. Remove the drain plug and allow the oil to drain.

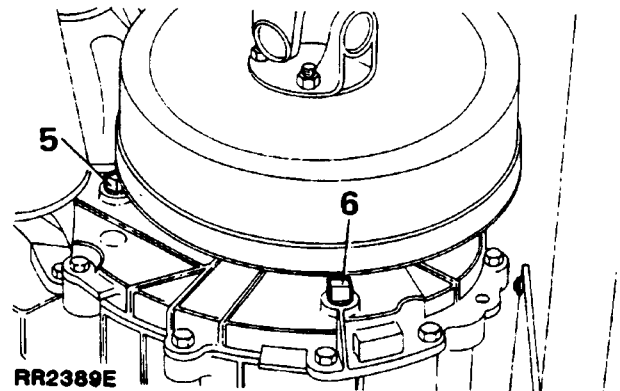

7. Thoroughly clean the drain plug threads prior to applying fresh 'Hylomar' sealant. Fit and tighten the plug to the specified torque.
8. Fill the gearbox with the correct quantity and grade of oil until oil seeps from the filler level hole. Wipe away any surplus oil.
9. Thoroughly clean the filler/level plug threads prior to applying fresh 'Hylomar' sealant. Fit and tighten the plug to the specified torque.
10. Reconnect the battery.

10 MAINTENANCE

ADJUST HANDBRAKE

1. Set the vehicle on level ground and select 'P' in automatic gearbox or neutral in manual gearbox. Disconnect the battery negative terminal.
2. Chock the road wheels.
3. Fully release the handbrake lever.
4. From underneath the vehicle, rotate the adjuster on the brake drum back plate clockwise until the brake shoes are fully expanded against the brake drum.

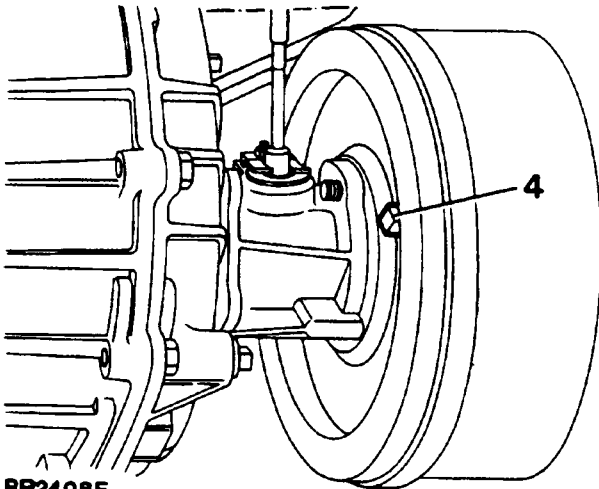

5. Back off the adjuster until the drum is free to rotate.
6. Release the four screws and remove the glove box liner.
7. Rotate the adjustment thumbwheel below the handbrake lever until the handbrake is fully operational on the third notch of the ratchet.

NOTE: The handbrake adjustment thumbwheel must only be used for initial setting and to compensate for cable stretch, it must not be used to take up brake shoe wear, which must continue to be adjusted at the brake drum.

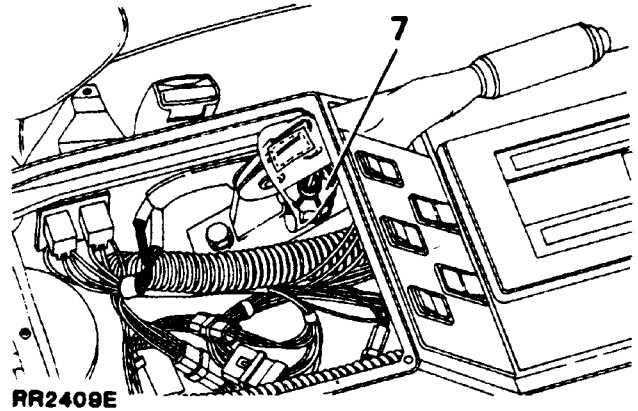

8. Operate the handbrake once or twice to settle the brake shoes, recheck that the handbrake is fully operational on the third notch of the ratchet. Readjust as necessary.
9. Refit the glove box liner.
10. Reconnect the battery and remove the wheel chocks.

ROLLING ROAD TESTING OF PERMANENT FOUR WHEEL DRIVE VEHICLES

NOTE: THIS INFORMATION APPLIES TO VEHICLES FITTED WITH BORG WARNER TRANSFER GEARBOX WITH VISCOUS COUPLING

These vehicles are identified by the absence of the diff-lock position on the transfer gearbox lever.

Viscous coupling

The front and rear axles cannot be driven independently due to the viscous coupling. This eliminates the need for the differential lock by progressively locking the centre differential automatically if any slip occurs at any wheel.

WARNING: DO NOT attempt to drive individual wheels with the vehicle supported on floor jacks or stands.

Four wheel rolling roads

Provided that the front and rear rollers are rotating at identical speeds and that normal workshop safety standards are applied, there is no speed restriction during testing except for any that may apply to the tyres.

Two wheel rolling roads

IMPORTANT: Use a four wheel rolling road for brake testing if possible.

If brake testing on a single axle rig is necessary it must be carried out with the propeller shaft to the rear axle removed, AND neutral selected in BOTH main gearbox and transfer gearbox. When checking brakes, run engine at idle speed to maintain servo vacuum.

If checking engine performance, the transfer box must be in high range and the propeller shaft to the stationary axle must be removed.

TOWING

Note the towing procedure for previous models applies to vehicles fitted with Borg Warner transfer gearbox. The main gearbox and transfer gearbox must be in neutral when the vehicle is being towed.

BORG WARNER TRANSFER GEARBOX

**VISCOUS UNIT (Front output housing)
- In vehicle check**

The viscous unit is located in the front output housing and its integrity can be checked while the unit is installed in the transfer gearbox as follows.

Remove either the front or rear propeller shaft from the vehicle to eliminate drive to one of the axles. If the viscous unit is operating effectively drive will be transferred to the axle that is still connected via the propeller shaft to the gearbox and the vehicle should remain driveable.

If the viscous unit has failed drive will not be transmitted to the axle.

A partially failed unit will be identified by excessively high engine revs and little vehicle movement when attempting to drive the vehicle.

IN - SITU OPERATIONS

The following operations can be carried out with the gearbox in the vehicle which for ease of working, should be raised on a ramp or placed over a pit. Disconnect the battery negative terminal

NOTE: The front and rear output housings can also be removed while the gearbox is in the vehicle. Reference should be made to the Overhaul procedure for the removal of these assemblies.

RENEW SPEEDOMETER DRIVE PINION

**NOTE: Driven gear identification: -
Non catalyst vehicles: RED
Catalyst vehicles : BLACK**

1. Remove the nut securing speedometer drive clamp and withdraw the cable. Prise the drive pinion assembly from the output housing.
2. Push in a new assembly, fit the speedometer cable and secure with the clamp and nut.

RENEW REAR OUTPUT SHAFT OIL SEAL

Service tool: 18G1422

1. Disconnect the rear propeller shaft from the output drive flange and tie the shaft to one side.
2. Ensuring that the handbrake is applied to restrain the drive flange, release the drive flange nut.
3. Release the handbrake and remove the two screws which secure the brake drum and withdraw the drum.

NOTE: While the brake drum is removed from the rear output housing the transmission brake assembly can be overhauled, the procedure for this operation is the same as the LT230, therefore reference should be made to Section 70 Brakes, of the main Workshop Manual.

4. Remove the bottom two bolts which secure the oil catcher to the back plate and withdraw the oil catcher.
5. Remove the output shaft nut, steel washer, rubber seal and withdraw the flange.
6. Carefully tap the dust cover from the housing and prise out the oil seal.
7. Lubricate and carefully install the new seal using service tool 18G1422 with the spring side of the seal abutting the circlip.
8. Fit the dust cover.
9. If necessary release the circlip from the drive flange to allow new bolts to be installed.
10. Examine the flange for damage or wear particularly the seal running surface, if the surface is corroded or a groove has been worn by the previous seal discard the flange.
11. Lubricate the seal running surface of the flange. Fit the flange, if necessary fit a new rubber seal, steel washer and secure with a new nut. Do not tighten the nut at this stage.
12. Seal the oil catcher to the back plate using silicone rubber sealant and secure the assembly with the two bolts.
13. Fit the brake drum and secure with the two screws. Apply the handbrake to restrain the drum and tighten the new drive flange nut to the specified torque.
14. Reconnect the propeller shaft and secure with new nuts, tighten to the specified torque.

Continued

RENEW FRONT OUTPUT SHAFT OIL SEAL**Service tool: 18G1422**

1. Disconnect the front propeller shaft from the flange and tie the shaft to one side.
2. Ensuring that the handbrake is applied to restrain the transmission release the drive flange nut.
3. Remove the output shaft nut, steel washer, rubber seal and withdraw the flange.
4. Prise out the oil seal.
5. Lubricate and carefully install the new seal using service tool 18G1422 with the spring side of the seal abutting the circlip.
6. Examine the flange for damage or wear, particularly the seal running surface, if the surface is corroded or a groove has been worn by the previous seal discard the flange.
7. Lubricate the seal running surface of the flange.
8. Fit the flange, if necessary fit a new rubber seal, steel washer and secure with a new nut, tighten to the specified torque.
9. Refit the propeller shaft and secure with new nuts tightened to the specified torque.

REMOVE TRANSFER GEARBOX

Adaptor plate for removing transfer gearbox

The transfer gearbox should be removed from underneath the vehicle, using a hydraulic transmission hoist. An adaptor plate for locating the transfer gearbox onto the hoist can be manufactured locally to the drawing below.

Material: Steel plate BS 1449 Grade 4 or 14.
Holes marked thus * to be drilled to fit hoist being used.

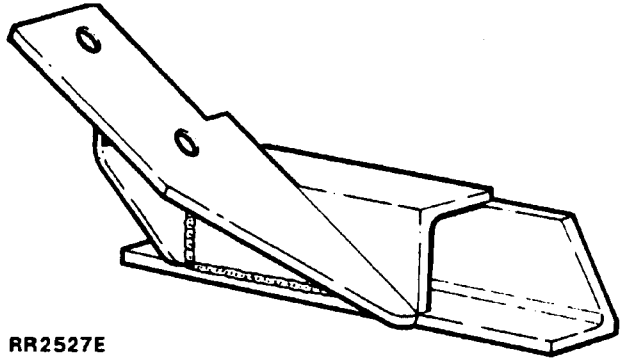

RR2527E

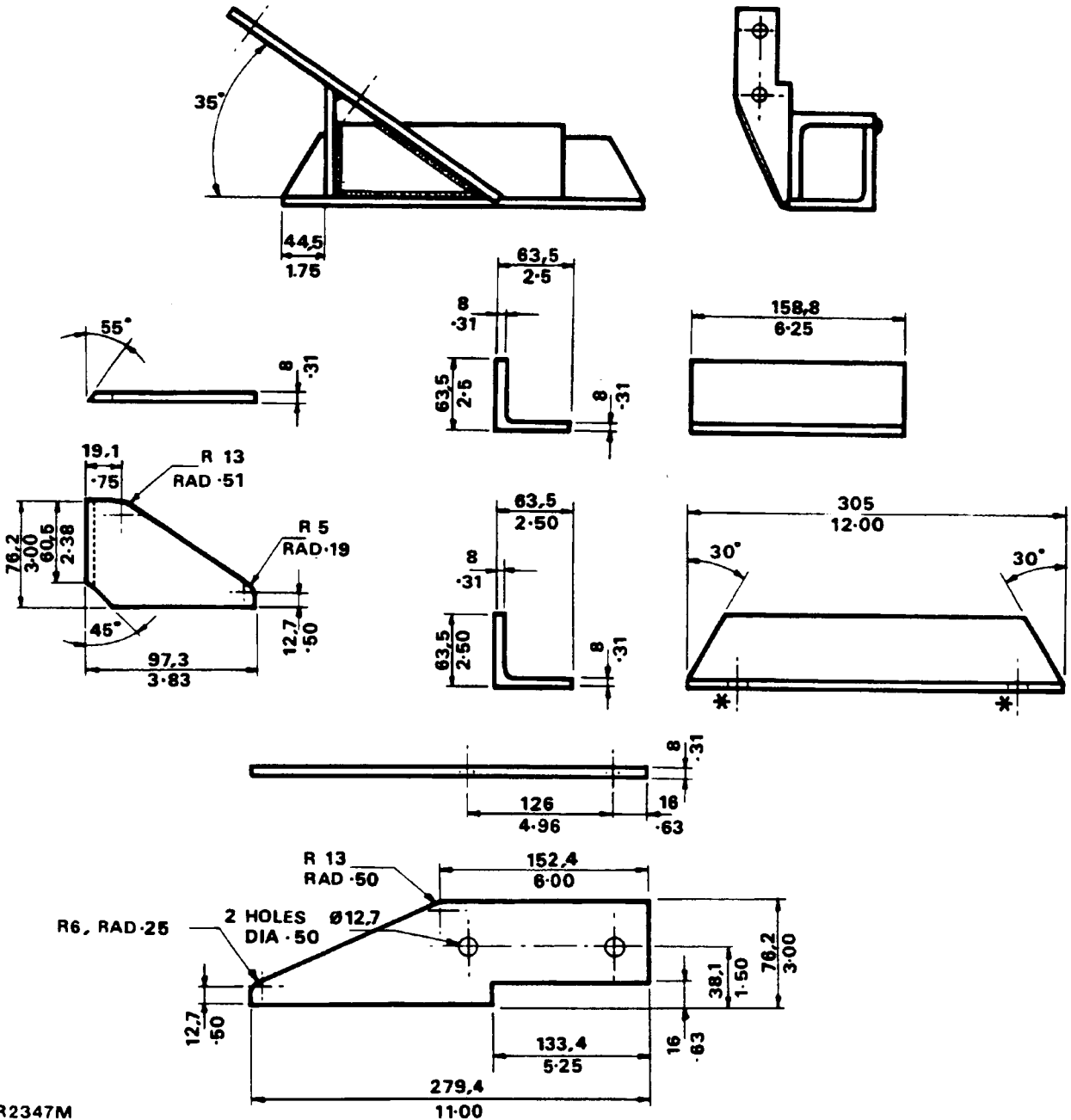

RR2347M

37 BORG WARNER TRANSFER GEARBOX

- 1. FRONT OUTPUT HOUSING ASSEMBLY
- 2. VISCOUS UNIT

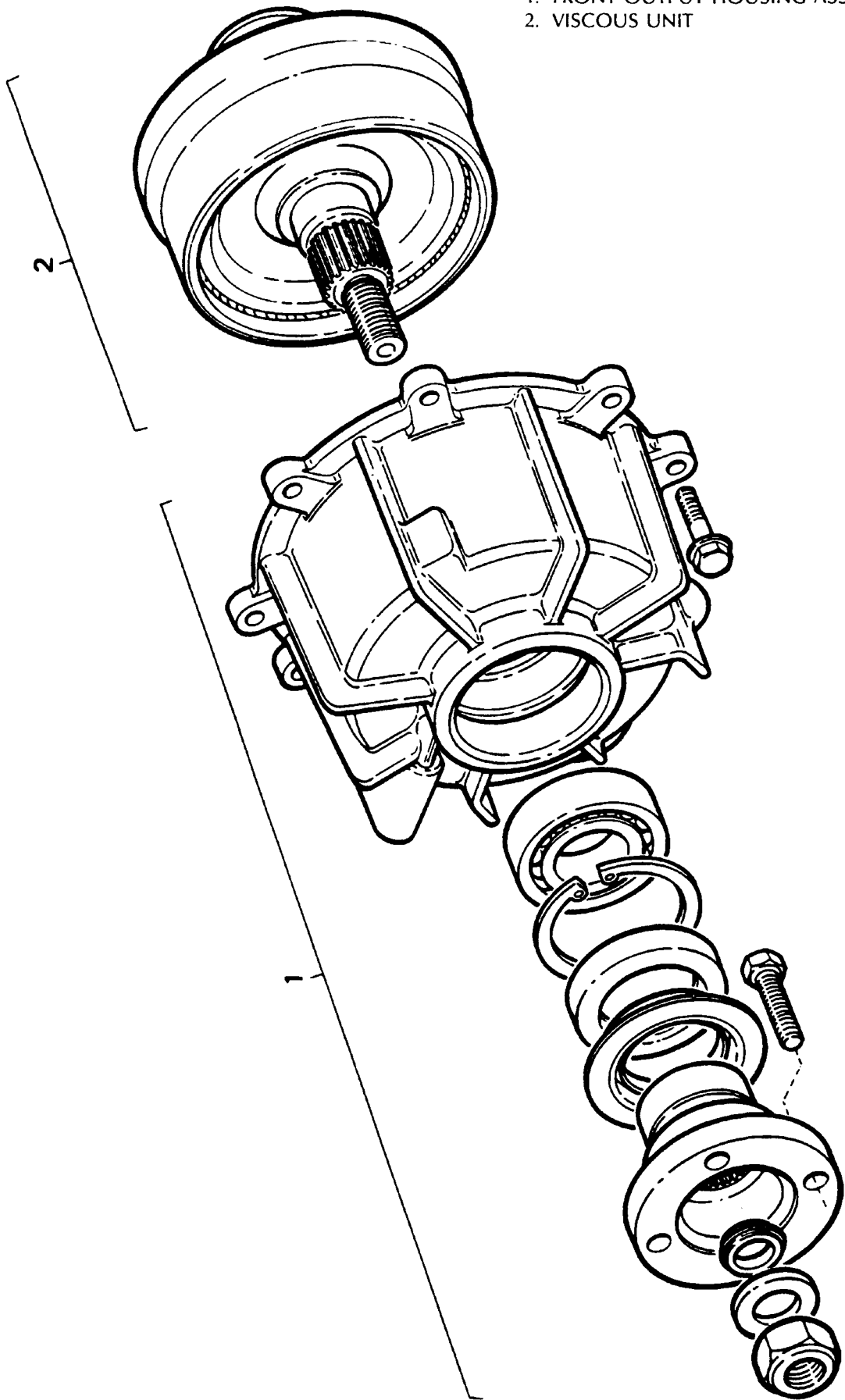

RR2390E

1. REAR OUTPUT HOUSING AND OUTPUT SHAFT ASSEMBLY
2. TRANSMISSION BRAKE DRUM ASSEMBLY
3. SPEEDOMETER DRIVE PINION ASSEMBLY

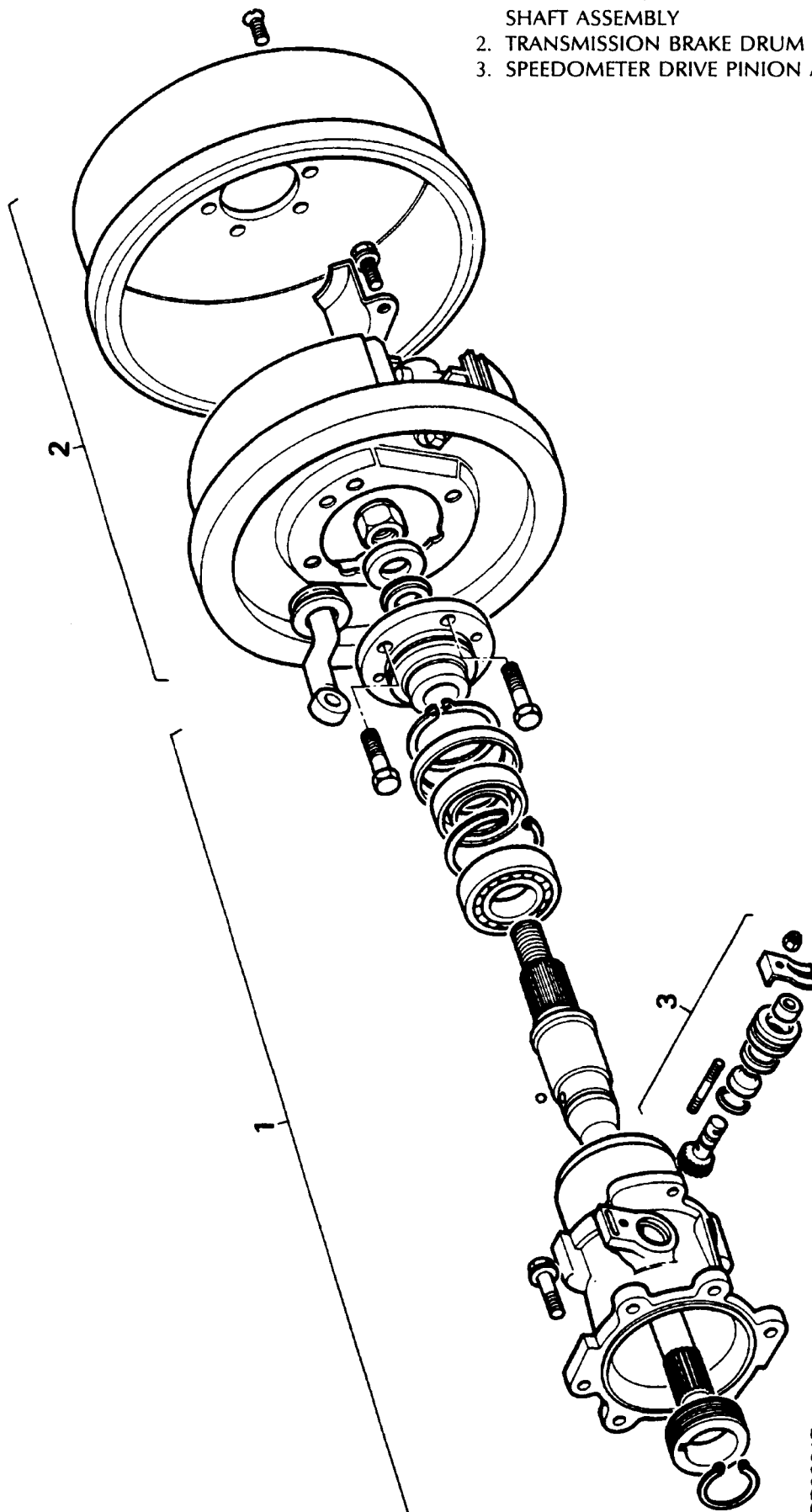

RR2301E

37 BORG WARNER TRANSFER GEARBOX

1. FRONT COVER - MAIN CASING
2. TRANSFER SPROCKET, CENTRE DIFFERENTIAL ASSEMBLY, DRIVEN SPROCKET AND CHAIN
3. BEARING CARRIER AND TRANSFER SHAFT
4. SELECTOR FORK AND LEVER ASSEMBLY
5. SELECTOR SLEEVE
6. OIL PICK - UP PIPE AND FILTER
7. PLANETARY SET (EPICYCLIC UNIT)
8. REAR COVER - MAIN CASE
9. END CAP

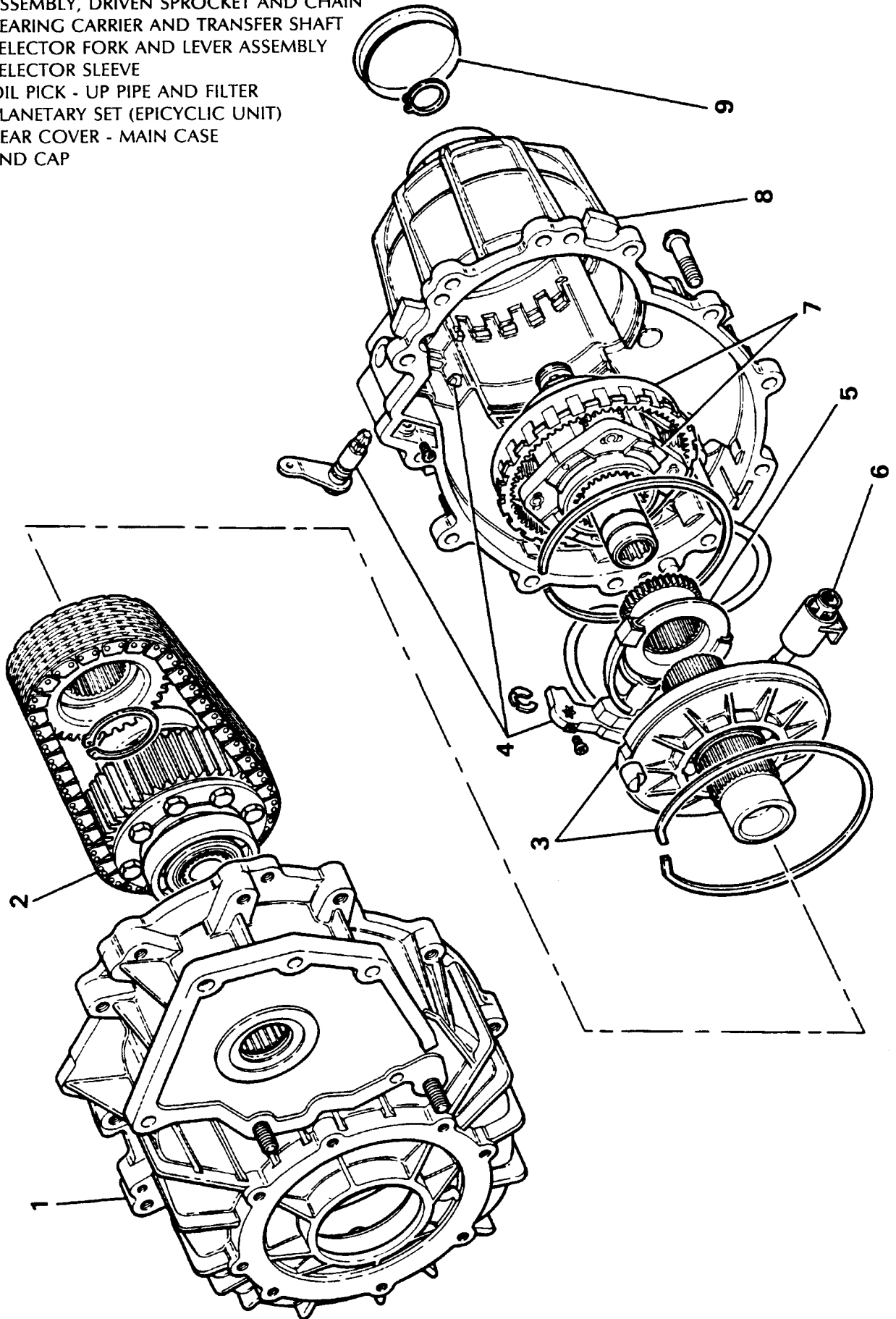

REMOVE TRANSFER GEARBOX

NOTE: The following preparation work is necessary prior to the removal of the gearbox to avoid unnecessary damage to associated components.

WARNING: Where the use of a transmission hoist is necessary, it is **ABSOLUTELY ESSENTIAL** to follow the hoist manufacturer's instructions to ensure safe and effective use of the equipment.

Preparation

Outside the vehicle

1. Install the vehicle on a ramp and chock the wheels. Disconnect the battery negative terminal.
2. Fuel Injection models only - release the airflow meter to plenum chamber hose.
3. Carburettor models only - Remove the air intake elbows and withdraw the air cleaner from its location.
4. Release and remove the fan blade assembly noting that the fan blade has a left hand thread, removing the fan blade assembly will enable the engine to be tipped rearwards when the transmission is ready to be removed.

Inside the vehicle

5. Remove the four screws securing the glove box liner to the glove box and lift out the liner. Detach the two relay mounting blocks from the clip on the side of the glove box.
6. Disconnect the electrical leads to the rear cigar lighter.
7. Carefully prise the window lift, switch panel away from the front of the glove box, manoeuvre the switch panel complete with switches back inside the glove box and allow to lie loose on the gearbox tunnel.
8. Select low range, unscrew and remove the transfer lever knob.
9. **Automatic gearbox models only** - Unclip the top cover of the main gearbox selector and remove the circlip, withdraw the detent button. Remove the circlip above the selector knob retention nut, remove the nut, serrated washer and withdraw the selector knob. **Manual gearbox models only** - Unscrew and remove the main gear lever knob.

10. Carefully prise the centre panel out of the floor mounted console (**Automatic models only** - disconnect the electrical leads to the graphics panel on the underside of the centre panel) and remove it from the vehicle.

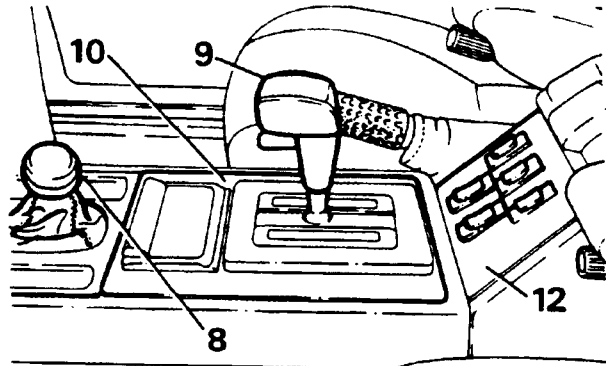

RR2578M

Automatic version illustrated

11. Release the two bolts and two screws securing the console assembly to the gearbox tunnel.

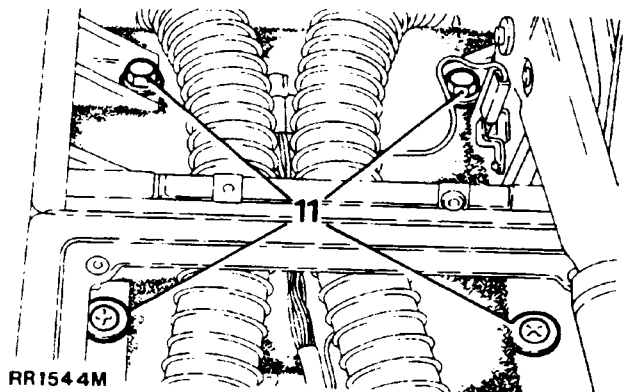

RR1544M

12. Release the handbrake, pull the gaiter forward to gain access to the clevis pin. Remove the split pin, clevis pin and washer securing the handbrake cable to the handbrake lever.
13. Detach the console locating tab from the radio housing by easing the console slightly rearwards.
14. Carefully manoeuvre the glove box assembly rearwards (while raising the handbrake lever to its uppermost position) away from the radio housing and remove the glove box assembly from the vehicle.

37 BORG WARNER TRANSFER GEARBOX

15. Remove the sound deadening material from the top of the gearbox tunnel. **Manual gearbox models only** - slacken the pinch bolt and remove the upper gear lever. Remove the four screws and detach the retaining plate securing the rubber gaiter to the top of the main gearbox.

Underneath the vehicle

16. Raise the the vehicle on the ramp and remove the transfer gearbox drain plug and allow the oil to drain into a suitable container, meanwhile continue with the preparation operations.

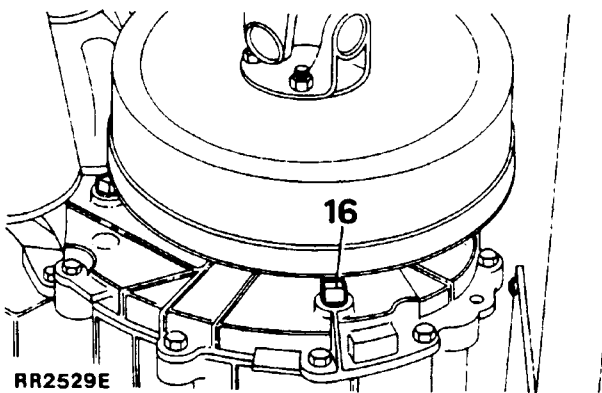

17. Refit the oil drain plug.
18. **Catalyst models only** - Disconnect the multi-plugs to the Lambda sensors.
19. Remove the crossmember from below the main gearbox.
20. Remove the front exhaust down pipes and intermediate pipe complete with centre silencer (or catalyst).

NOTE: Operation 19 will require the assistance of a second operator to support the exhaust system while the various fixings are released.

21. Remove the underbody floor mounted centre silencer heat shield.
22. Mark each drive flange with an identification line to aid reassembly. Remove the nuts securing the front and rear propeller shafts to the transfer gearbox and tie both shafts clear of the working area.

23. Release the clamp and withdraw the speedometer cable from the rear output housing, also free the cable from the clip at the left hand side of the transfer gearbox.
24. **Automatic models only** - Remove the three fixings securing the tie bar to the transmission.
25. Secure the adaptor plate to the gearbox hoist with two nuts and bolts.

NOTE: To ensure that the weight of the transfer gearbox is centralised on the hoist, fit the adaptor plate on the hoist platform so that the split line of the gearbox is aligned with the centre line of the ram.

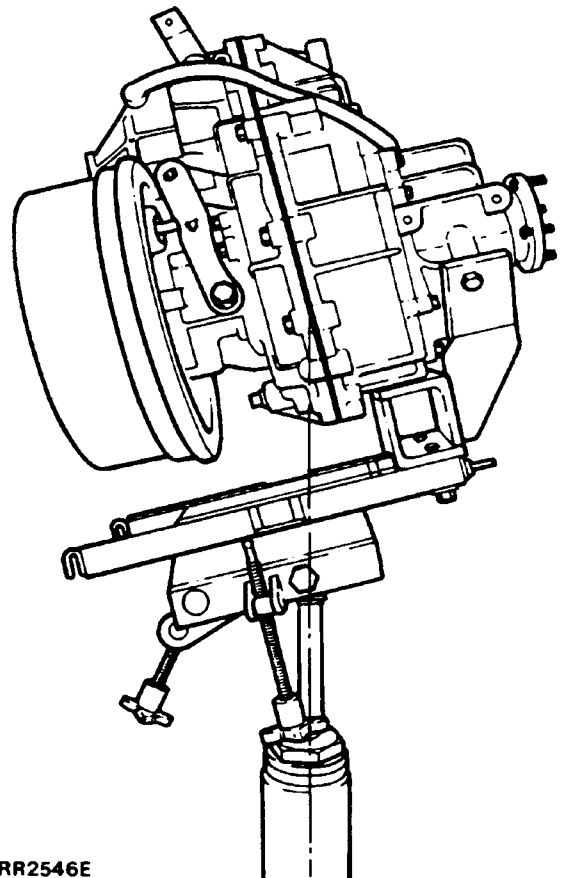

Remove the transfer gearbox

26. Using a suitable hydraulic hoist, support the main gearbox.

27. Slacken the transfer gearbox right hand mounting rubber, upper nut and remove the lower nut. Remove the fixings and withdraw the transfer gearbox to chassis outer half of the mounting bracket.
28. Remove the inner half of the mounting bracket from the transfer gearbox.
29. Adjust the height of the hoist and place in position under the transfer gearbox so that the adaptor plate holes align with the transfer gearbox mounting bracket location.
30. Using the two short bolts previously removed from the right hand gearbox mounting bracket, secure the adaptor plate to the gearbox.

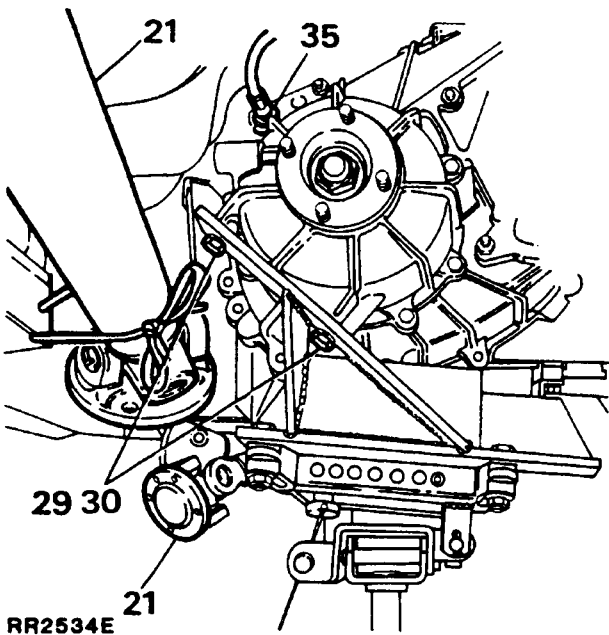

RR2534E

31. Remove the fixings securing the left hand mounting bracket to chassis.
32. Lower the front hoist to allow the transmission to be lowered.
33. Lower the transmission assembly until the top of the transfer gearbox clears the rear passenger footwell.
34. Remove the split pin, clevis pin and washer securing the handbrake cable to the brake drum actuating lever and disconnect the cable.
35. Remove the clip that secures the handbrake cable to the support bracket, feed the cable through the bracket and tie the cable to one side.

36. Remove the breather pipe from the top of the transfer gearbox.
37. Release the spring clip retaining the clevis pin, withdraw the clevis pin and clip assembly, remove the high/low rod from the transfer gearbox selector lever.

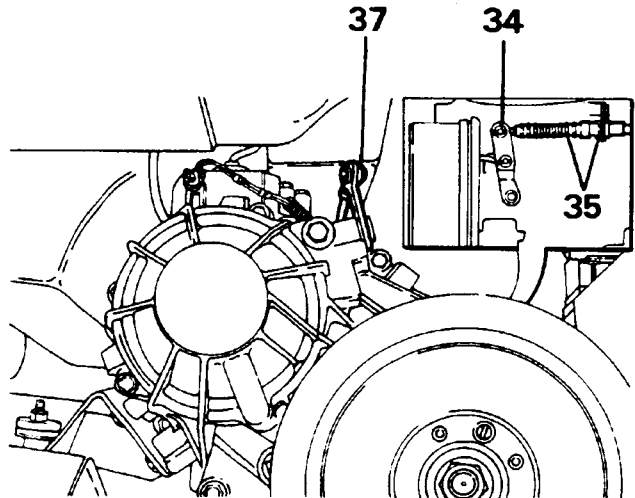

RR2537E

38. Support the main gearbox with the previously removed hoist before detaching the transfer gearbox.
39. Remove the upper and lower bolts and two nuts securing the transfer box to the main gearbox.
40. Manoeuvre the transfer gearbox rearwards to detach it from the main gearbox.
41. Thoroughly clean the exterior of the transfer gearbox before undertaking the overhaul procedure.

Continued

37 BORG WARNER TRANSFER GEARBOX

Transfer Gearbox - Refitting

42. Ensure that the joint faces of the transfer gearbox and main gearbox extension case are clean.
43. Lubricate the oil seal in the joint face of transfer gearbox, secure the transfer gearbox to the adaptor plate on the lifting hoist and raise the hoist until the input shaft enters the transfer gearbox.

CAUTION: CARE MUST BE TAKEN DURING THIS OPERATION TO ENSURE THAT THE INPUT SHAFT SPLINES DO NOT DAMAGE THE OIL SEAL IN THE TRANSFER GEARBOX.

During this process it may be necessary to rotate either one of the drive flanges to engage the input shaft splines.

44. Secure the transfer gearbox to the main gearbox by fitting the nuts to the two studs. Fit the remaining bolts noting that the longest bolt is fitted to the upper left hand fixing that locates the ring dowel and tighten all fixings to the correct torque.

Transfer gearbox high/low link adjustment

45. Ensure that the selector lever at the gearbox is in the neutral position.
46. Set the transfer gearbox lever in a vertical position (at right angles to the centre line of the main gearbox), rotate the clevis on the end of the rod clockwise or counter clockwise which will shorten or lengthen the operating rod until the hole in the clevis aligns with the hole in the selector lever.
47. Fit the clevis pin and retaining clip assembly. Select high and low transfer to ensure full engagement is occurring. Repeat the above procedure if full engagement is not evident.

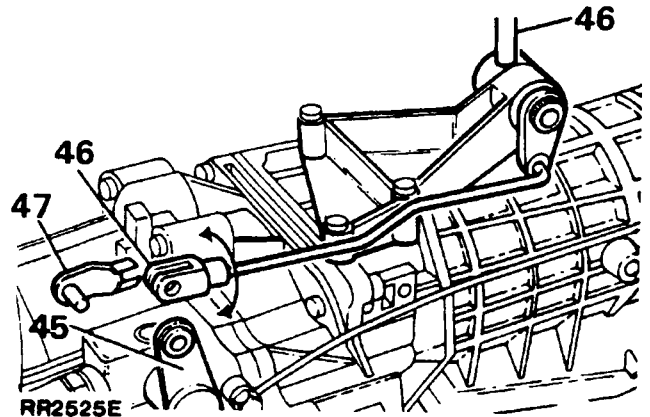

Refitting (continued)

48. Complete the refitting procedure by reversing the removal sequence, noting the following important points.
49. After removing the lifting hoist and adaptor plate from the transfer gearbox, clean the threads of the bolts for the transfer gearbox and fit them together with the mounting bracket to the gearbox. Tighten to the specified torque.
50. Fit the three fixings which secure the right hand mounting bracket to the chassis. Tighten to the specified torque.
51. Fit the propeller shafts and tighten to the specified torque.
52. Remove the transfer gearbox combined oil filler and level plug, refill the transfer gearbox with the correct grade and quantity of oil until the oil starts to seep from the filler/level hole. Coat the plug with Hylomar sealant and refit the combined filler and level plug. Tighten to the specified torque, wipe away any surplus oil.
53. Check, and if necessary top - up the oil level in the main gearbox. Use the correct grade oil.
54. Check the operation of the handbrake and adjust as necessary.

BORG WARNER TRANSFER GEARBOX

DISMANTLING, OVERHAUL AND REASSEMBLY

Service Tools:

- 18G1422 - Oil seal replacer
- 18G1205 - Adjustable flange holding wrench
- 18G134 - Bearing and oil seal replacer
- LST550 - 6 - Input shaft oil seal replacer

NOTE: Before commencing the overhaul procedure thoroughly clean the exterior of the transfer gearbox. If the gearbox oil has not previously been drained, drain the oil into a suitable container.

DISMANTLING

NOTE: Before commencing the dismantling procedure remove the brake drum assembly (refer to section 70 - Brakes, of the main Workshop Manual).

Rear output housing

1. Remove the six bolts and withdraw the rear output housing complete with output shaft.

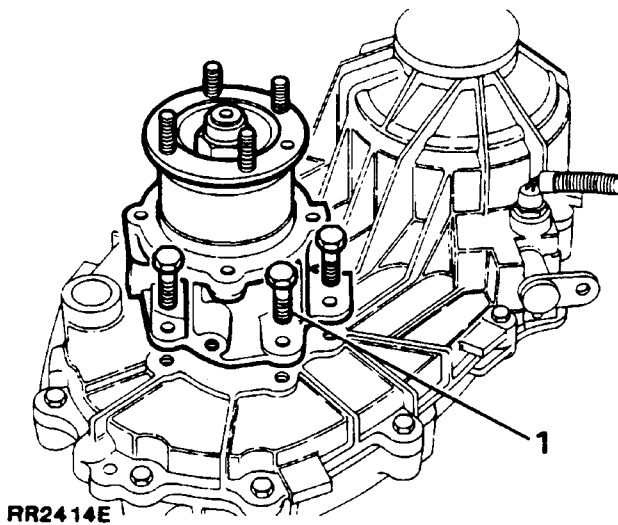

Front output housing

NOTE: Invert the gearbox. Level up the assembly by placing wooden blocks under the transfer gearbox to main gearbox joint face.

2. Remove the eight bolts and withdraw the front output housing complete with viscous unit.

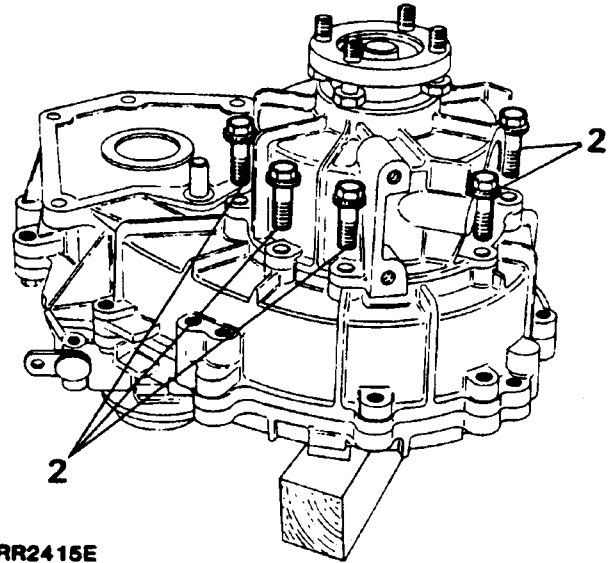

Front cover - main casing

3. Remove the eleven bolts securing the front and rear cover (main case) together.

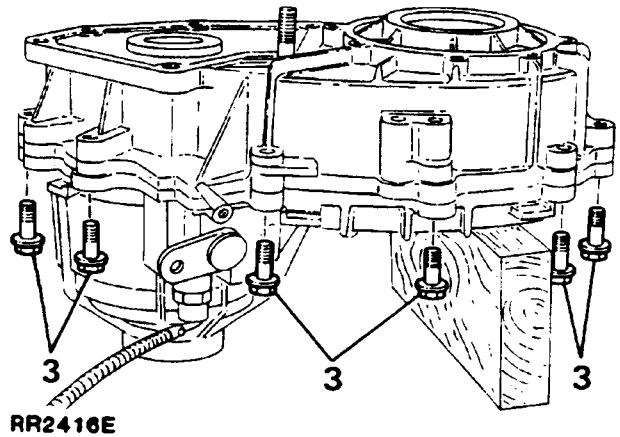

4. Clean any previous sealant from the threads of the bolts.

Continued

37 BORG WARNER TRANSFER GEARBOX

- Using two levers between the cast lugs on the outer edges of the casing, to assist in separating the gearbox, carefully prise the front cover from the rear cover.

CAUTION: DO NOT LEVER BETWEEN THE MATING FACES.

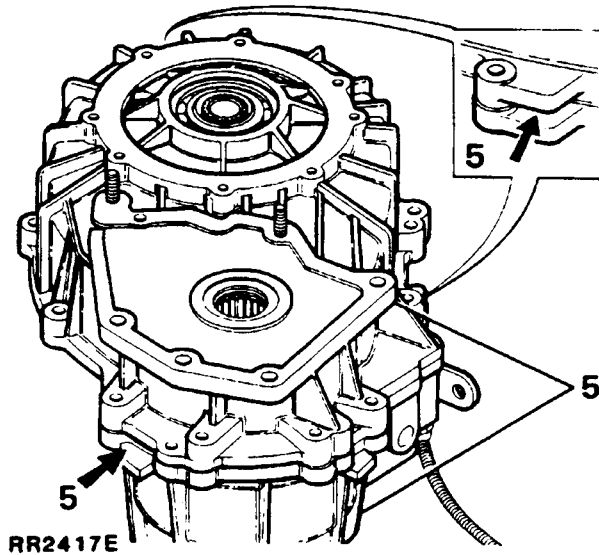

Transfer sprocket, centre differential, assembly and chain

NOTE: Before dismantling, mark one chain link and corresponding tooth on the transfer sprocket with an identification line. This is to ensure that the balance of the unit is maintained when reassembled with original components and that the chain is fitted the correct way up.

- Remove the circlip retaining the transfer sprocket to the transfer shaft.
- Place two thin pieces of wood on the joint face to prevent damage and using two levers behind the differential bearing assembly carefully lever the differential bearing from its bore while simultaneously easing the transfer sprocket off the transfer shaft to maintain alignment during removal.
- Remove the transfer sprocket from the chain.
- Remove the differential assembly from the chain.

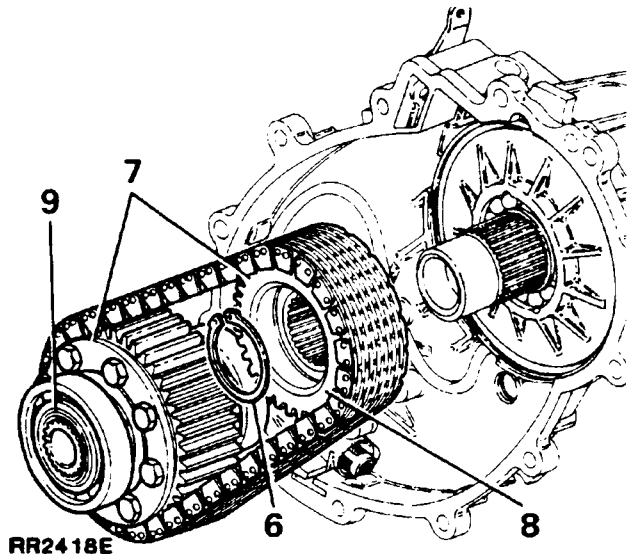

Bearing carrier and transfer shaft

- Insert a screw driver between the anti-rotation dowel and snap ring gently prise the snap ring out of the groove.
- Withdraw the carrier complete with transfer shaft.
- Withdraw the anti-rotation dowel.

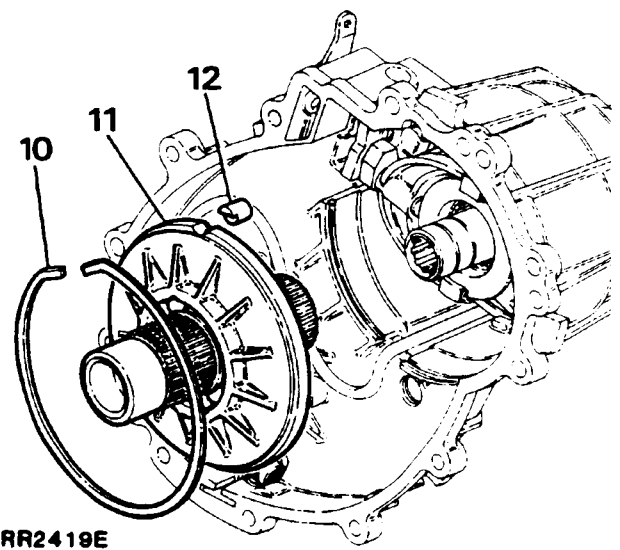

Selector fork assembly

- Using Torx bit 25 remove the screw securing the selector arm to the selector lever shaft.
- Remove the retaining clip securing the selector fork arm to the selector lever shaft.

15. Using Torx bit 25 remove the screw retaining the selector lever.
16. Remove the selector lever shaft from the case and fork assembly.
17. Withdraw the selector fork assembly and selector sleeve.

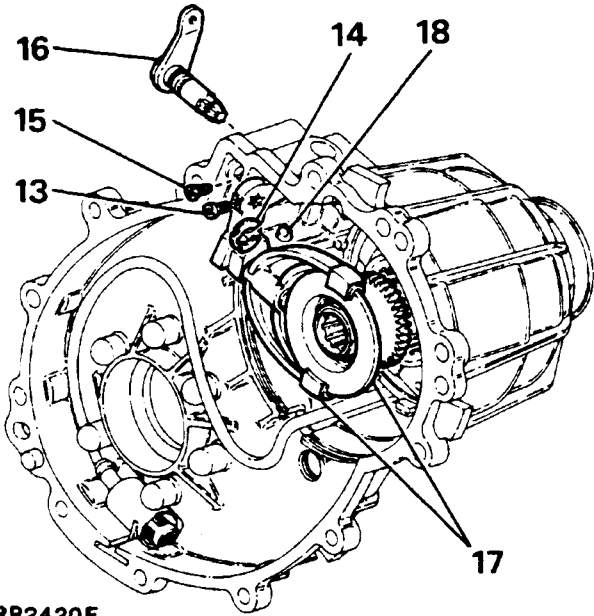

RR2420E

18. Retrieve the selector plunger and spring from the rear cover.

Planetary set (Epicyclic unit)

19. Turn the case over and prise the end cap off the planetary set housing.
20. Remove the circlip retaining the sun gear shaft.

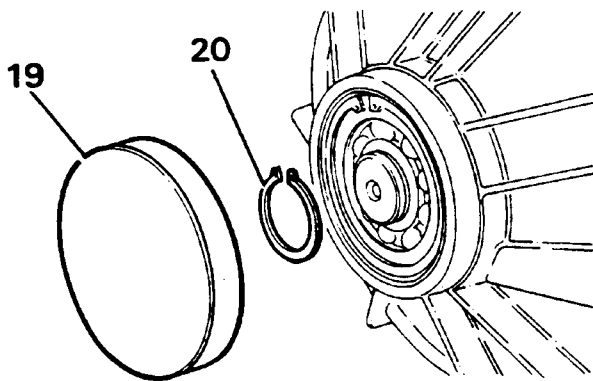

RR2421E

21. Turn the casing over and remove the large snap ring retaining the planetary set.
22. Withdraw the annulus and planetary assembly from the planetary set housing, complete with oil pump, feed pipe and filter.

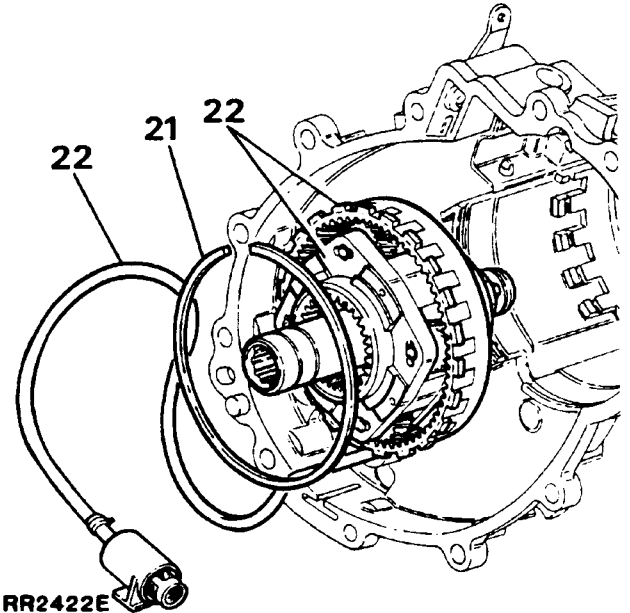

RR2422E

DISMANTLE, INSPECTION AND OVERHAUL

Rear cover main case - Dismantle and inspection

1. Remove the circlip retaining the bearing in the rear cover.
2. Drive or press the bearing from the cover and discard the bearing.

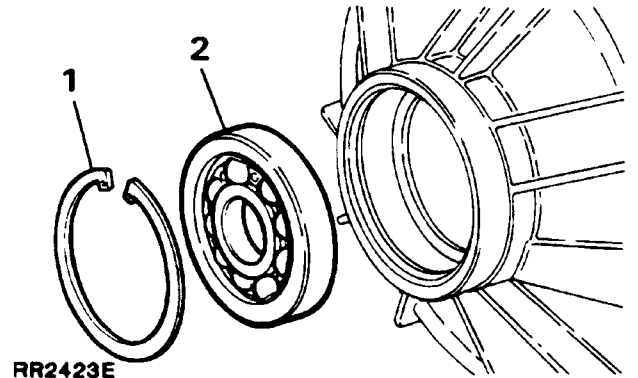

RR2423E

Continued

37 BORG WARNER TRANSFER GEARBOX

3. Remove any previous sealant evident on the rear cover joint faces.
4. Using a suitable solvent thoroughly clean the cover.
5. Examine the cover for damage, cracks and porosity, renew if necessary.
6. Check the selector lever shaft bore, for ovality and wear. If worn renew the cover.

Rear cover main case - Assemble

7. Drive or press a new bearing into the cover and secure in position with the circlip.
8. Place the cover aside until the gearbox is ready to be assembled.

Front cover main case - Dismantle and inspection

9. Prise the input shaft oil seal from the front cover and discard the oil seal.

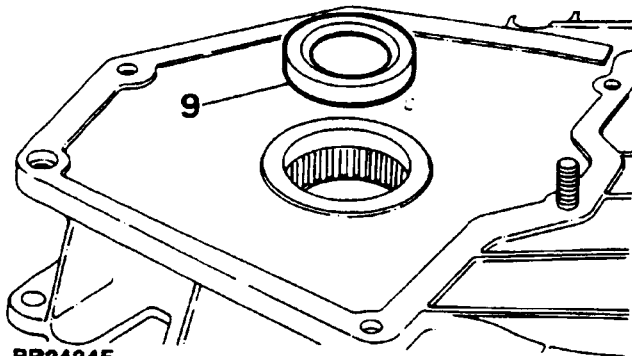

RR2424E

10. Remove the snap ring retaining the needle roller bearing, withdraw the bearing and discard.

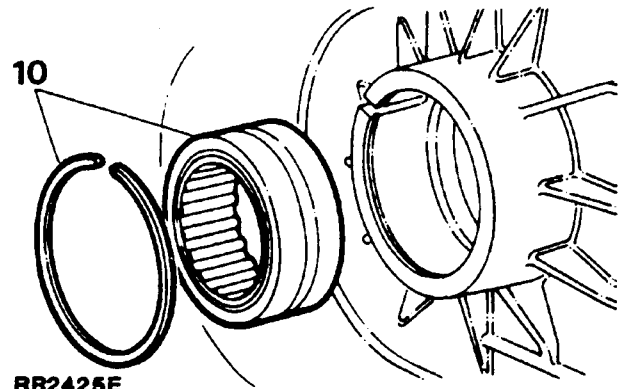

RR2425E

11. Remove any previous sealant from the joint faces of the front cover.
12. Thoroughly clean the cover using a suitable solvent.
13. Examine the cover for damage, cracks and porosity, renew if necessary.
14. Check the inside edges of the case for witness marks which may indicate a chain that has stretched.

Front cover main case - Assemble

15. Lubricate a new oil seal. Using service tool LST 550 - 6 in conjunction with bearing and oil seal replacer 18G134 fit the seal, open side of the seal leading, until the face of the seal is 1 mm (0.039 in) below the surface of the boss.

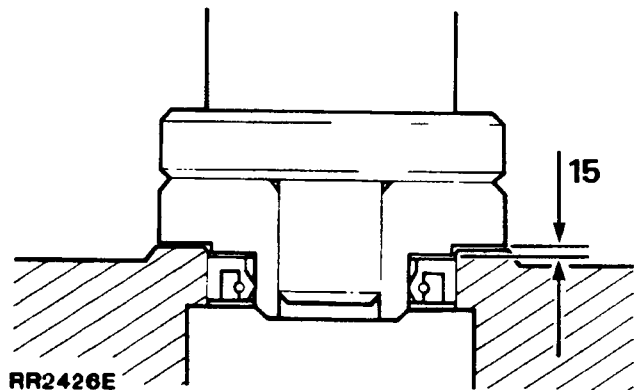

RR2426E

16. Lubricate a new needle roller bearing and drive or press the bearing into its recess until contact is made with the shoulder at the bottom of the bore.
17. Fit the snap ring to retain the bearing.
18. Place the cover aside until the gearbox is ready to be assembled.

**Planetary set (Epicyclic unit) and oil pump -
Dismantle and inspection**

NOTE: The Epicyclic unit and oil pump are serviced as a complete assembly, if after inspection either of the units is found to be worn a complete new assembly must be fitted.

1. Remove the annulus from the planetary set.

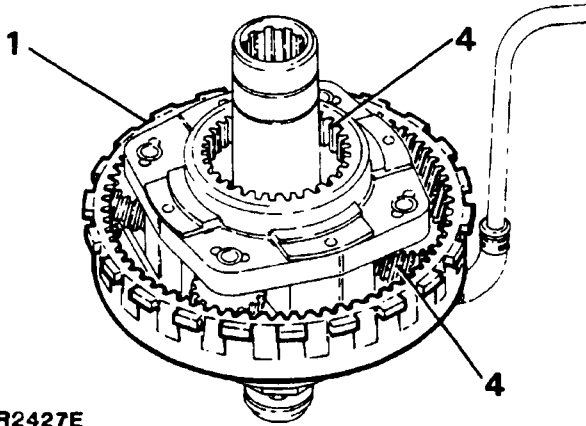

RR2427E

2. Thoroughly clean all components using a suitable solvent.
3. Examine the helical teeth of the annulus for wear or damage. If damage is evident it will be necessary to renew both the annulus and planetary set.
4. Examine the planetary gears and high/low gear teeth for wear or damage. If damaged renew both the annulus and planetary set.
5. Check the end float of the four planet gears, between the end of the gear and planetary set carrier. End float of each planet gear should not exceed 0.83 mm (0.033 in) if any one of the planet gears is out of limits renew the planetary set assembly.

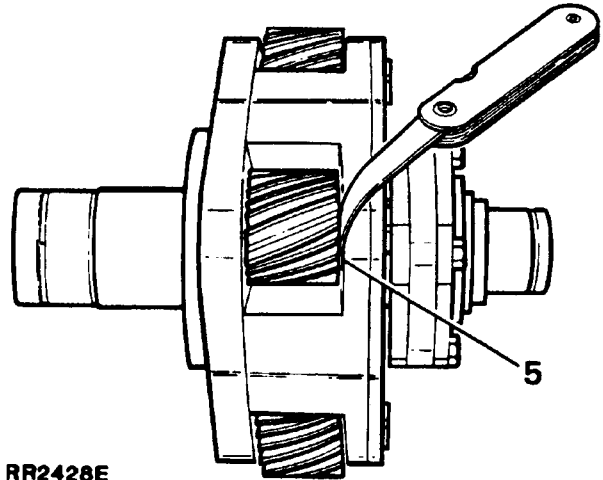

RR2428E

6. Check the end float of the sun gear to the planetary set carrier by supporting the body of the assembly on the top of a vice. Using a dial test indicator attached to a magnetic base, position the base on top of the assembly and zero the indicator on the end of the sun gear shaft, lift the shaft and check the end float. End float should not exceed 0.83 mm (0.033 in). Fit a new planetary set assembly if out of limits.

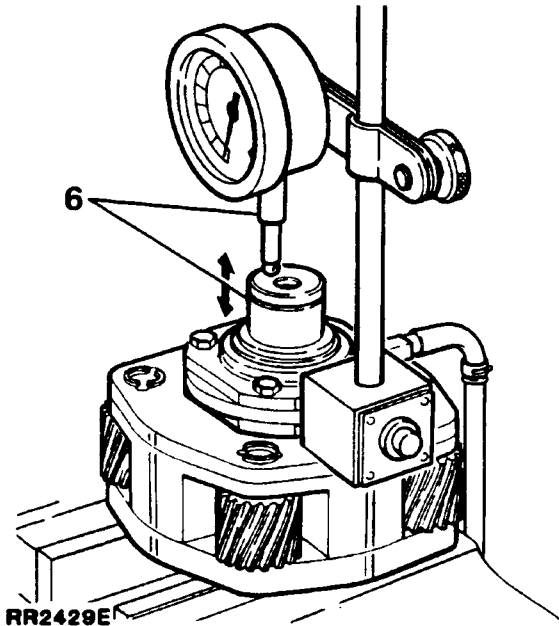

RR2429E

NOTE: If the previous inspection instructions prove the assembly to be in an acceptable condition carry out the following examination of the oil pump.

Continued

Oil pump and filter - Dismantle and inspection

- To aid re - assembly mark an identification line on the edges of the oil pump plates. Remove the four bolts securing the pump front and rear plates, separate the pump by removing the plungers, spring and bearing plate.

NOTE: The front plate of the oil pump is stamped 'TOP', the centre bearing plate is stamped 'REAR' and the rear plate is stamped 'TOP REAR'. The fixing holes of the plates and body are also offset to ensure correct re - assembly of the pump.

- Depress the retaining clips, remove the oil pick - up pipe and rubber connection tubes. Examine the tubes and pipe for damage or fractures, renew as necessary.

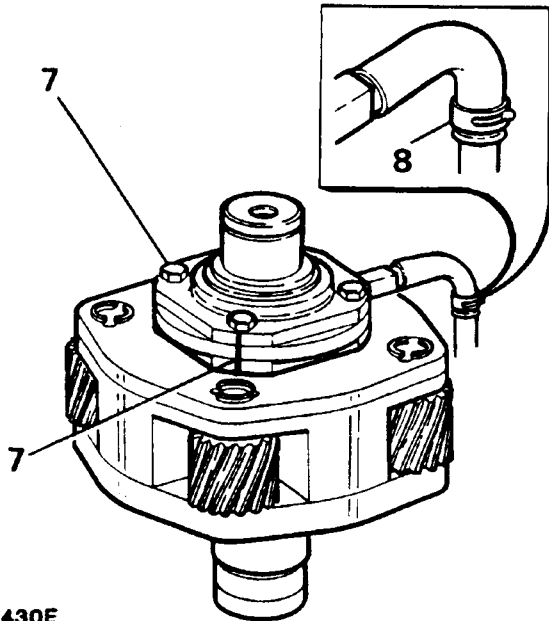

RR2430E

- Clean the pump components and check for damage and wear, ie: blueing of the pump plungers, scoring of the centre bearing plate, if any wear is evident a new planetary set must be fitted, as the pump is part of the complete assembly.
- Thoroughly clean the oil pick - up filter, examine the filter screen for damage and blockage, renew or clean the filter as necessary.

Oil pump and filter - Assemble

- Clean the sealant from the oil pump securing screws.
- Prior to assembly lubricate the pump components with clean oil.
- Fit the plate stamped 'TOP' to the sun gear shaft with the word 'TOP' facing the planetary assembly.
- Fit the plungers and spring noting that the flats on the plungers must be uppermost to enable the 'TOP REAR' plate to be fitted.
- Compress the plungers and fit the middle bearing plate with the word 'REAR' uppermost. Align the offset fixing holes and also noting the previously marked identification line.
- Fit the top rear plate with the words 'TOP REAR' uppermost.
- Apply Loctite 242 to the threads of the four screws and fit the screws, tighten to the specified torque.

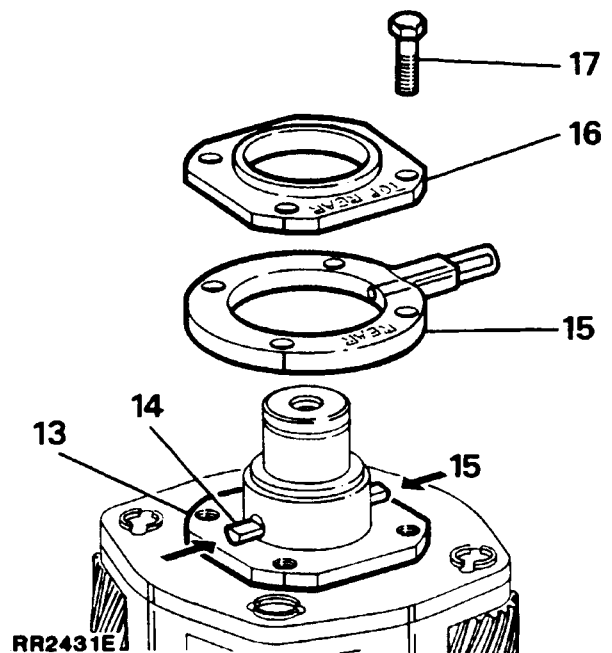

RR2431E

- Fit the rubber connection tube and oil pick - up pipe to the oil pump, fit the retaining clip. Note that the clip securing the tube to the pick - up pipe is positioned in front of the flare on the pipe.

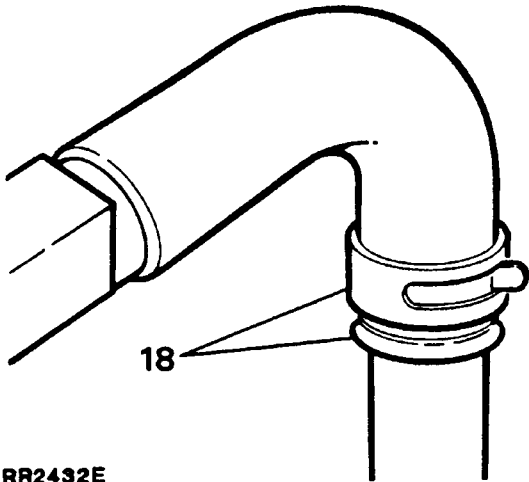

RR2432E

19. Fit the rubber connection tube to the filter end of the pipe, fit the clip ensuring that the tube is clamped by the clip in front of the flare on the pipe.
20. Push the filter into the tube. The radial position of the filter to pipe at this stage is unimportant.

Planetary set (Epicyclic unit) and annulus - Assemble

21. Lubricate the planetary set and annulus with clean oil.
22. Position the annulus around the planetary set, fit the assembly to the rear cover locating the oil pump inlet port in the groove at the bottom of the planetary set housing, the sun gear shaft in the bearing and the lugs on the outer edge of the annulus in the anti-rotation lugs. It may be necessary to tap the sun gear shaft into the bearing to enable the large ring gear snap ring to be fitted.

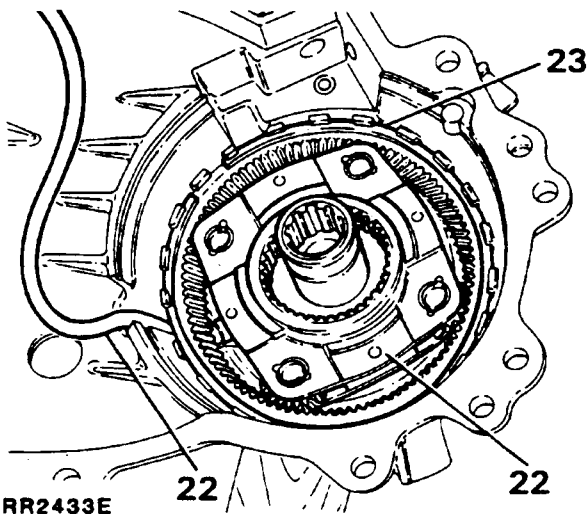

RR2433E

23. Fit the snap ring with the stepped ends adjacent to the selector shaft bore.
24. Turn the rear cover over and fit the circlip to retain the sun gear shaft.
25. Remove any previous sealant from the end cap. Apply Dow Corning 732 silicon sealant or a suitable equivalent to the inner edges of the cap, evenly tap the cap into position.

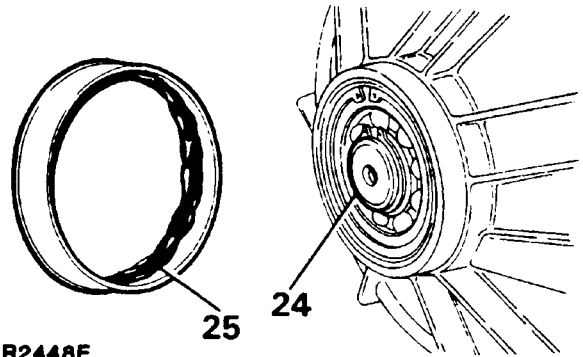

RR2448E

26. If necessary re-position the filter on the oil pick-up pipe until the lug on the filter can be pushed into the slot in the rear cover.

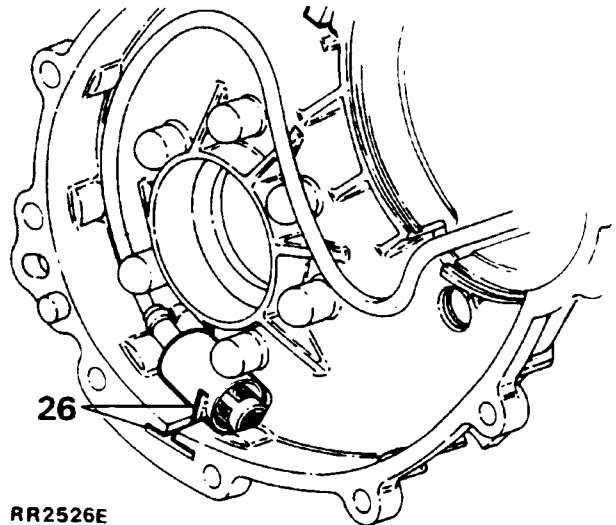

RR2526E

Continued

37 BORG WARNER TRANSFER GEARBOX

Selector fork

- Dismantle and inspection

1. Remove the retaining clip and separate the fork from the arm.
2. Detach the two nylon slippers from the selector fork feet and discard.
3. Thoroughly clean all components.
4. Examine the fork, arm and pivot pin for wear. Renew as necessary.
5. Remove the 'O' ring and discard. Examine the shaft and lever for wear and damage, renew as necessary.
6. Examine the selector sleeve teeth and internal splines for damage and wear. Renew as necessary.

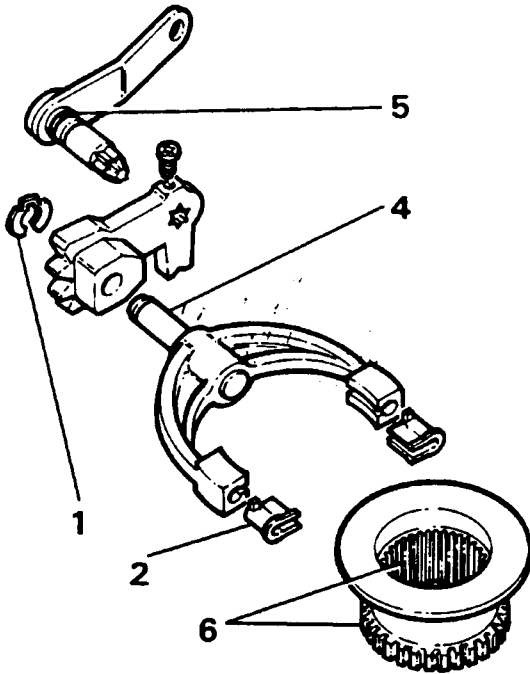

RR2434E

Selector fork - Assemble

7. Fit new nylon slippers to the fork.
8. Assemble the fork to the selector arm and secure in position using a new retaining clip.
9. Lightly lubricate and fit the spring and selector plunger.

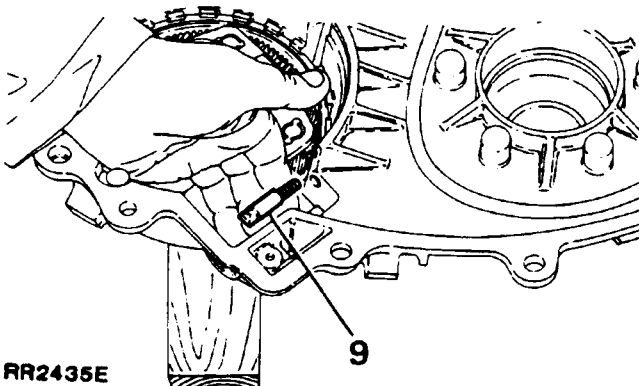

RR2435E

10. While compressing the plunger and spring, fit the selector fork, operating arm assembly and selector sleeve simultaneously.
11. Select neutral gear position at the operating arm.
12. Fit a new 'O' ring to the selector lever shaft. Lubricate the 'O' ring and fit the lever assembly to the rear cover, noting that when fully assembled the lever should lie parallel with the joint face of the rear cover.

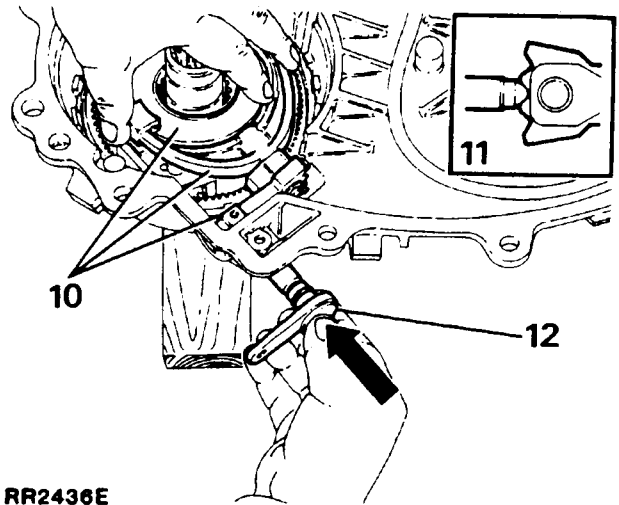

RR2436E

13. Fit a new retaining clip to secure the selector fork operating arm to the selector lever's shaft.
14. Remove any previous sealant from the Torx screw. Align the selector lever shaft groove to the retaining screw hole, apply a small amount of Loctite 242 to the screw threads and using Torx bit 25 fit and tighten the screw to the specified torque. Ensure that the screw locates in the groove of the shaft.

15. Clean any previous sealant from the Torx screw. Apply a small amount of Loctite 242 to the threads of the screw and fit to the selector fork operating arm, tighten using Torx bit 25 to the specified torque.

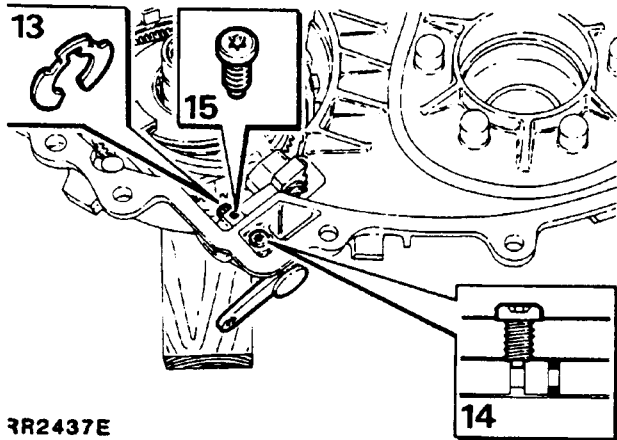

RR2437E

Bearing carrier

- Dismantle, inspection and assemble

1. Remove the circlip and drive or press the transfer shaft from the bearing.
2. Remove the circlip retaining the bearing in the carrier.
3. Drive or press the bearing from the carrier and discard the bearing.
4. Clean and examine the carrier for cracks and general condition. Renew as necessary.
5. Press or drive a new bearing into the carrier and secure with the circlip.

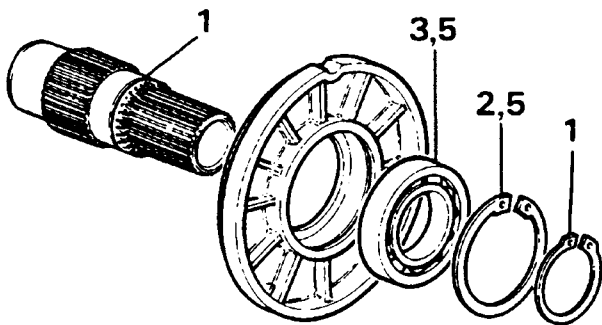

RR2438E

Transfer shaft

- Inspection and assemble

1. Clean the transfer shaft.
2. Visually examine the external splines for damage and wear, if worn fit a new the component.
3. Check the phosphor bronze bush for wear by measuring the internal diameter of the bush with internal calipers and a micrometer or with an internal micrometer. The bush diameter must not exceed 38.515 mm (1.516 in) fit a new transfer shaft if the bush has worn above the figure given.

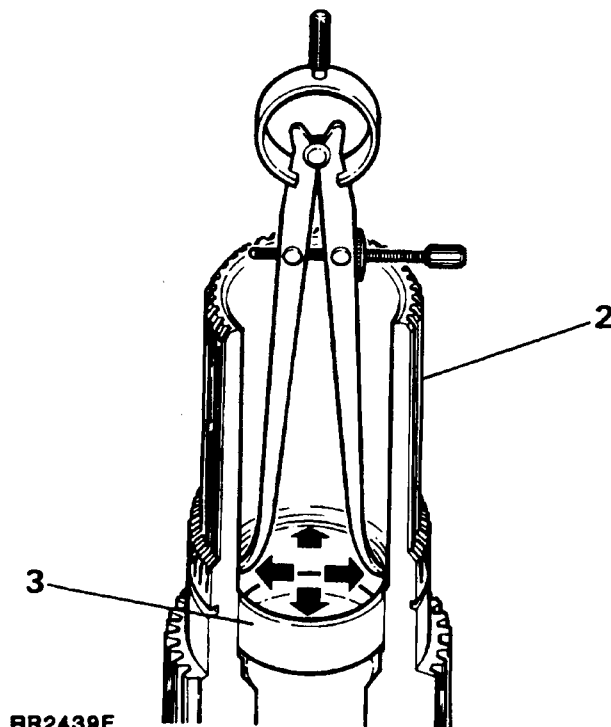

RR2439E

Continued

4. Drive or press the transfer shaft into the bearing in the carrier. Secure the shaft with the circlip.
5. Fit the carrier to the rear cover, fit the anti-rotation dowel and secure the assembly with the snap ring, noting that the open ends of the snap ring must be positioned by the cast relief in the bearing carrier upper face.

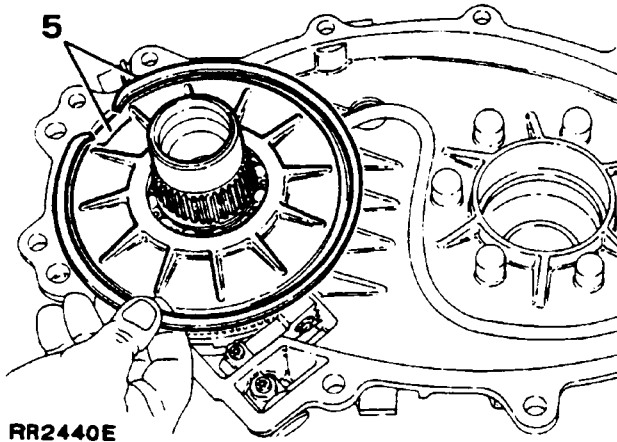

Transfer sprocket - Inspection

1. Examine the sprocket teeth and splines for wear and damage, if either are evident discard the sprocket, otherwise clean and place to one side.

Chain - Inspection

NOTE: A stretched chain can be identified by either excessive noise when the gearbox is operational or by witness marks on the inside edges of the case. If either is evident, renew the chain.

1. Using a suitable solvent thoroughly clean the chain.
2. Check the chain links for wear and damage, if necessary renew the chain.
3. Place the chain to one side.

Centre differential and sprocket - Dismantle and inspection

1. Place the differential unit in a vice fitted with soft jaws. If the original components are to be refitted mark an identification line on the sprocket and differential unit.
2. Remove the bolts securing the sprocket to the differential.
3. Lift the differential assembly from the sprocket.

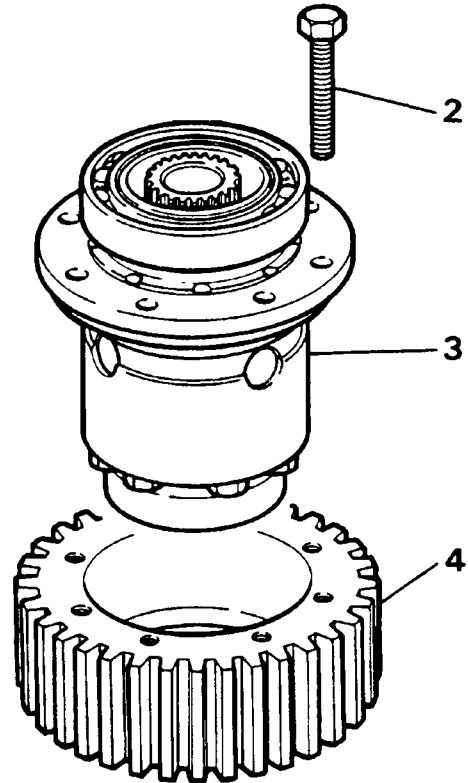

4. Examine the sprocket teeth for wear and damage, if either are evident renew the sprocket. Place the sprocket aside until the differential is ready to be assembled.

**Centre differential
- Dismantle and inspection**

1. Using a two legged puller, ease the bearings from the differential assembly and discard the bearings.

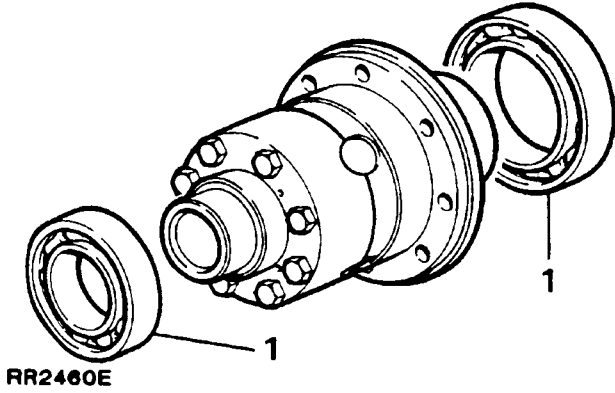

2. Secure the front half of the differential unit in a vice fitted with soft jaws, remove the eight retaining bolts securing the front and rear halves of the assembly together, lift off the rear part of the differential unit. Note the identification marks on the exterior of the differential unit.

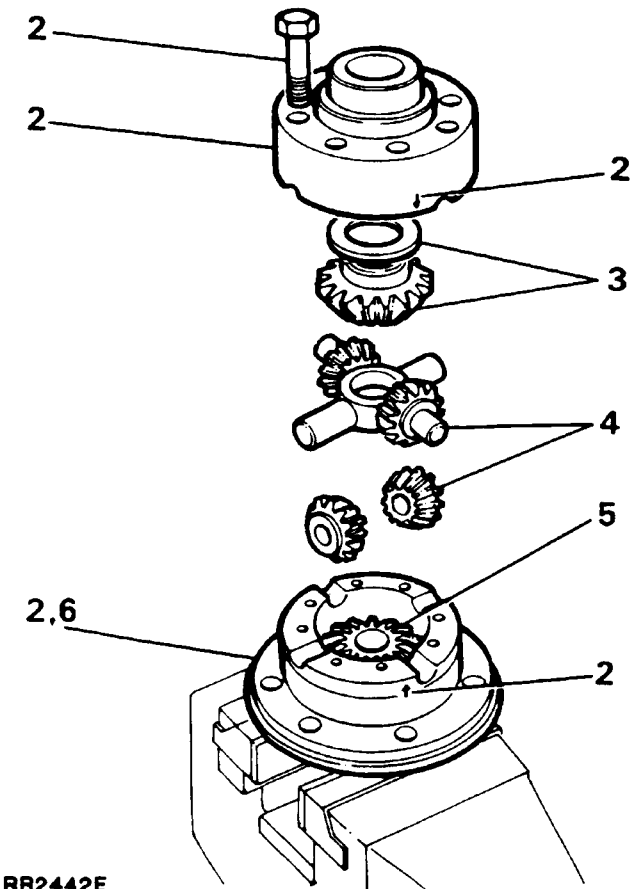

3. Remove the rear upper bevel gear and thrust washer.
4. Remove the pinion gears and dished washers along with the cross shaft.
5. Remove the front lower bevel gear and thrust washer from the front half of the differential unit.
6. Remove the front half of the differential unit from the vice and clean all components. Examine for wear or damage, renew if necessary.

Differential pinions - rolling resistance

7. Using soft jaws secure the front half of the differential unit in the vice.
8. Fit the front bevel gear without the thrust washer. Lightly lubricate and fit the cross shaft, pinion gears and new dished washers.
9. Fit the rear bevel gear together with the thinnest thrust washer to the rear half of the differential. Assemble both halves of the differential noting the identification marks. Fit the bolts and tighten to the specified torque.

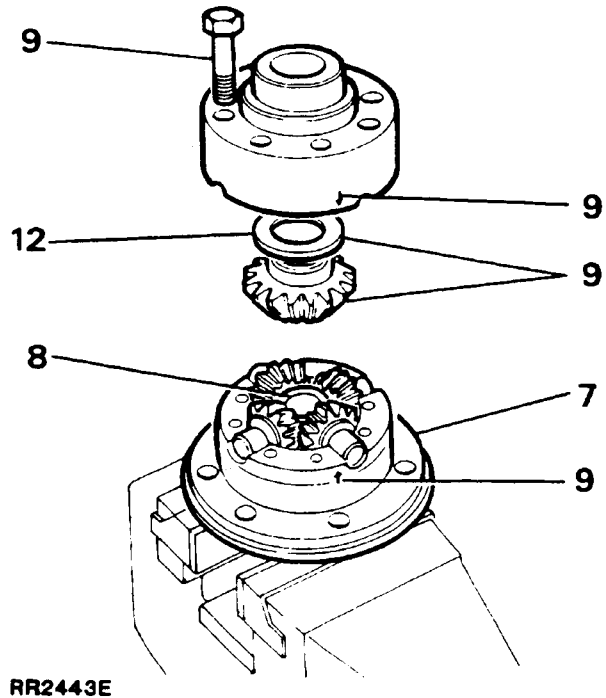

Continued

10. Invert the differential unit in the vice, fit the front output housing to the differential, locating the viscous unit splines on the front bevel gear. Fit the drive flange to the viscous unit and place the brake drum on top of the drive flange, secure with the nut. Check that the gears are free to rotate.
11. Tie a length of string around the brake drum, attach a spring balance to the free end and carefully tension the string until a load to turn is achieved. Alternatively use a torque wrench applied to the drive flange nut. Rotate the brake drum slowly by hand to overcome the initial load when using either method.

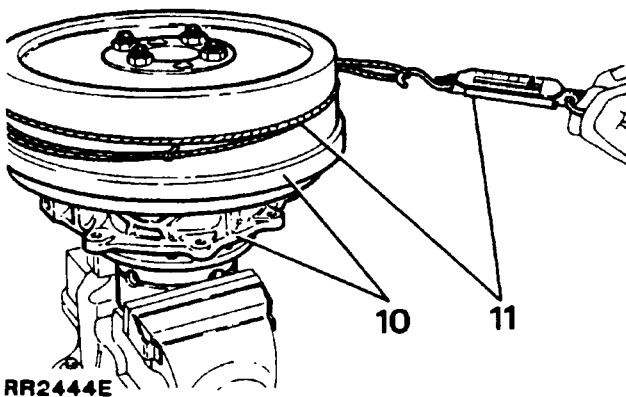

NOTE: Gears that have been run will rotate smoothly and will require a torque of 0.56 Nm (5 in lb), equivalent force using a spring balance 0.45 kg (1 lb). New gears will rotate with a notchy feel and will require a torque of not more than 2.26 Nm (20 in lb), equivalent force using a spring balance 7.72 Kg (3.8 lb). Keep all components lubricated when carrying out these adjustments.

12. Change the thrust washer for a thicker one if the torque reading is too low and re - check the torque. Five thrust washers are available in 0.10mm steps ranging from 1.05 to 1.45mm.
13. Dismantle the unit when the rear bevel gear thrust washer has been selected.
14. Remove and retain the rear bevel gear and thrust washer combination.

15. Repeat the procedure to obtain the correct thrust washer for the front bevel gear, it is not necessary to fit the rear bevel gear when checking the front bevel gear rolling resistance.
16. When the thrust washer has been selected for the front bevel gear, again dismantle the differential unit and retain the thrust washer and front bevel gear combination.

Centre differential - Assemble

17. Fit the thrust washer and front bevel gear into the front half of the differential unit.
18. Fit the pinion gears with dished washers to the cross shaft and fit the assembly to the differential unit.
19. Fit the thrust washer and rear bevel gear to the rear half of the differential unit.
20. Align both halves of the differential noting the identification marks. Secure both halves together with the eight bolts. Tighten the bolts to the specified torque.

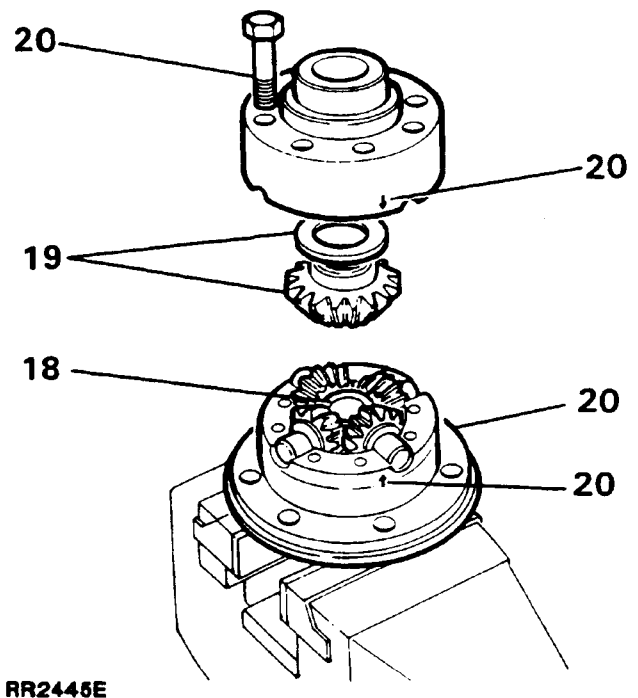

21. Check the overall torque required to turn the differential, this should be approximately equal to both bevel gears added together.
22. Drive or press new bearings onto the differential, noting that the smaller of the two bearings is fitted to the rear half of the differential.

Centre differential sprocket - Assemble

1. Fit the sprocket to the differential noting that the face of the sprocket with the relieved threads must contact the flange of the differential housing. Observe the previously marked identification lines if the original components are being refitted.
2. Fit new bolts and tighten evenly to the specified torque.

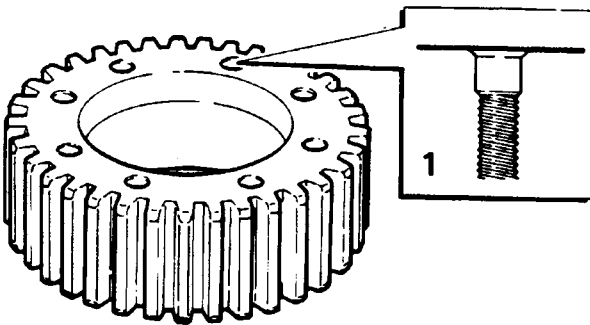

RR2446E

Transfer sprocket, centre differential assembly and chain - Assemble

1. Place the differential assembly and transfer sprocket inside the chain. If the original components are being refitted observe the identification marks previously applied to the chain and transfer sprocket. Fit the complete assembly simultaneously.
2. Carefully tap the differential bearing into its bore while easing the transfer sprocket onto the transfer shaft.

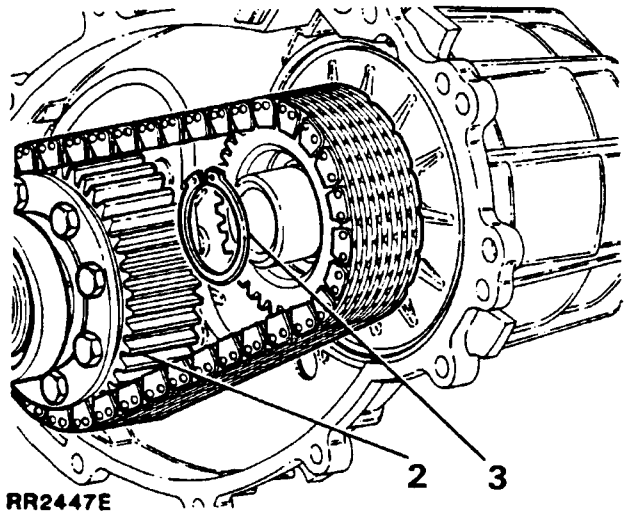

RR2447E

3. Ensuring that the transfer sprocket is fully down, secure the sprocket to the transfer shaft with the circlip.

Continued

37 BORG WARNER TRANSFER GEARBOX

Front and rear cover - main casing - Assemble

1. Ensuring that the joint faces of the front and rear covers are clean, apply a bead of Dow Corning 732 or a suitable equivalent silicone sealant to the joint face of the rear cover and evenly spread the sealant over the face. Do not over apply the sealant.
2. Fit the front cover, secure with the eleven bolts, tightening evenly to the specified torque. Do not wipe away the surplus sealant which is forced out of the joint.

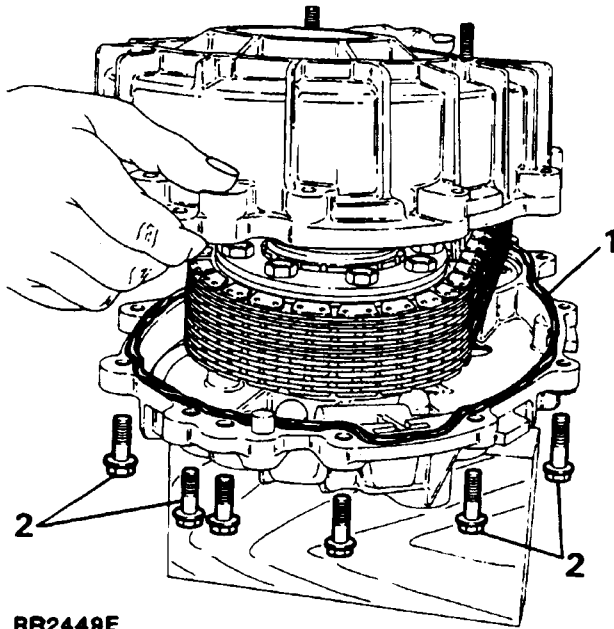

RR2449E

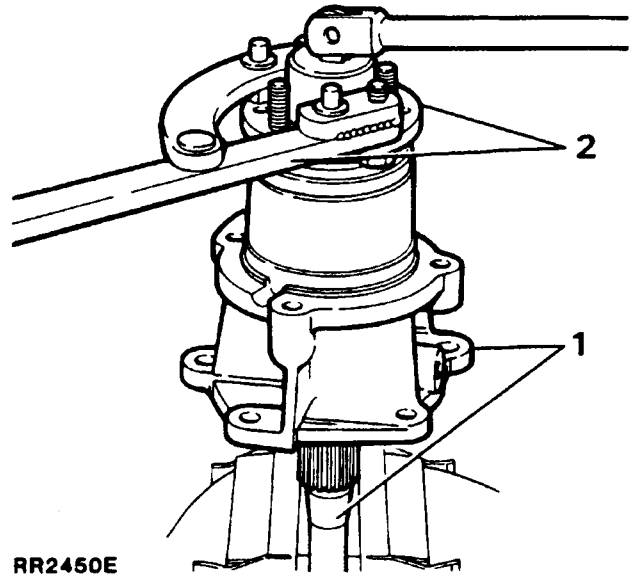

RR2450E

3. Remove the drive flange from the output shaft. Examine the flange for damage or wear particularly the seal running surface, if the surface is corroded or a groove has been worn by the previous seal discard the flange.
4. Prise the speedometer sleeve and driven gear from the housing. Examine the gear teeth for wear, if worn discard the gear.
5. Prise the oil seal from the sleeve and remove the 'O' ring, discard both the seal and 'O' ring.
6. Clean the sleeve and place to one side.
7. Drive or press the output shaft from the housing.

Rear output housing - Dismantle and inspection

Service tools:

18G1422 - Oil seal replacer

18G1205 - Adjustable flange holding wrench

1. Support the rear output housing by the output shaft in a vice fitted with soft jaws.
2. Using service tool 18G1205 to restrain the drive flange, release and remove the nyloc nut and plain washer securing the drive flange to the output shaft, withdraw the rubber seal. Discard the nut and seal.

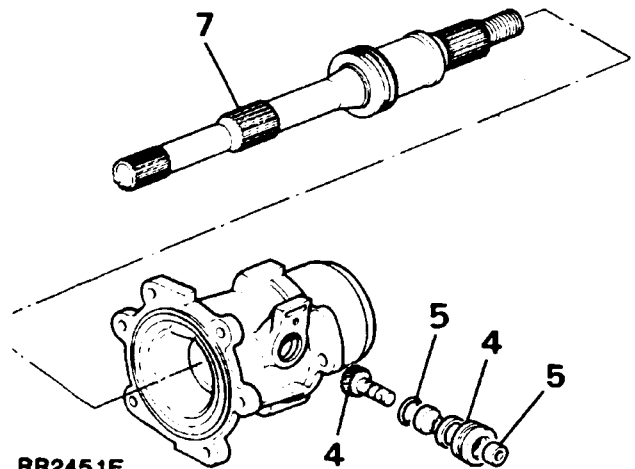

RR2451E

- Clean and examine the splines and speedometer drive gear for wear or damage. The output shaft can be further dismantled if either the speedometer drive gear or output shaft is worn: remove the circlip and slide the gear from the shaft, retrieve the ball bearing from the indent in the shaft. Discard the worn component.

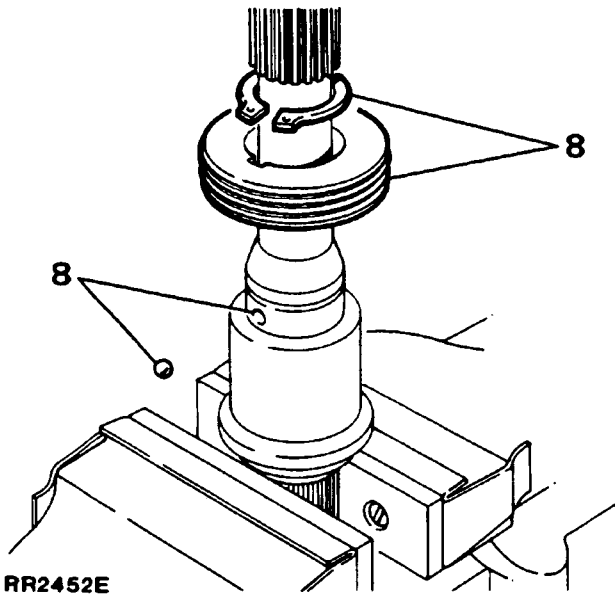

NOTE: While the output shaft is removed from the rear output housing, the shaft can be utilised for checking the rolling resistance of the viscous unit as follows.

**Viscous unit - rolling resistance
Bench check**

NOTE: Testing should be carried out in an ambient of 20 °C.

- Secure the output shaft in a vice fitted with soft jaws, gripping the shaft on the drive flange splines.
- With the viscous unit still installed in the front output housing place the assembly on the rear output shaft spline.
- Apply a torque of 27 Nm (20lb ft) to the output flange nut, if no resistance to turn is felt, the viscous unit requires replacing.

- If resistance to turn is felt, apply a torque of 20 Nm (20lb ft), to the output flange nut for 1 minute, this should result in a rotation of approximately 25° - 30°. If this does not occur, the unit requires replacing.

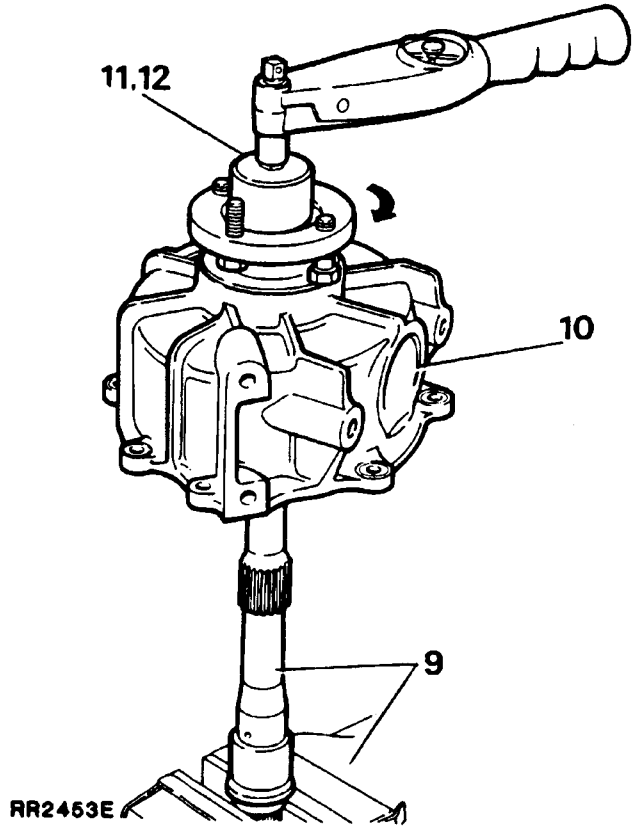

Rear output housing (continued)

- Lever off the dust shield.
- Prise the oil seal from the housing and discard the seal.
- Remove the circlip retaining the bearing.
- Drive or press the bearing from the housing. Discard the bearing.
- Remove any previous sealant from the housing joint face.

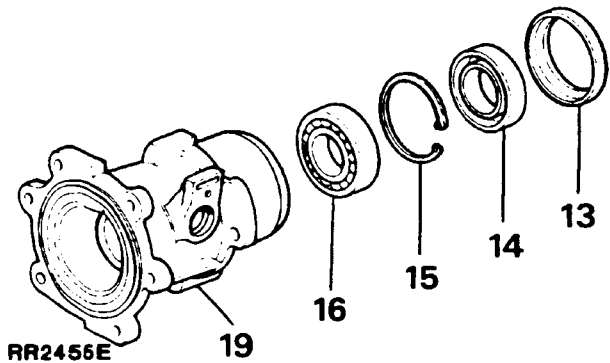

Continued

18. Thoroughly clean all components with a suitable solvent.
19. Examine the housing for damage and wear. Renew as necessary.

Rear output housing - Assemble

20. Drive or press a new bearing into the housing until the bearing contacts the shoulder.
21. Fit the circlip.
22. Lubricate a new oil seal. Using oil seal replacer 18G1422 fit the seal, lip side leading until it contacts the circlip.
23. Fit the dust shield.
24. Place the ball bearing in the indent on the output shaft, fit the speedometer drive gear to the shaft, secure together with the circlip.
25. Press or drive the output shaft into the housing until the shoulder of the shaft contacts the bearing.
26. Lubricate the oil seal bearing surface of the drive flange and fit the flange followed by a new rubber seal. Fit the steel washer and secure the flange to the shaft using a new nut. Tighten to the specified torque.
27. Lubricate a new speedometer sleeve oil seal, press the seal into the top of the sleeve.
28. Fit a new 'O' ring to the outside of the sleeve, push the driven gear spindle into the sleeve.
29. Lubricate the 'O' ring and push the sleeve and gear assembly into the housing. It may be necessary to rotate the output shaft to ensure that the driven gear engages with the drive gear on the shaft.
30. Apply Dow Corning 732 or a suitable equivalent silicone sealant to the rear output housing joint face on the main casing. Evenly spread the sealant on the face to ensure a good seal.
31. Fit the housing to the main casing and secure with the six bolts tightened to the specified torque.

**Front output housing
- Dismantle and Inspection****Service tools:****18G1422 - Oil seal replacer.****18G1205 - Adjustable flange holding wrench**

1. Support the viscous unit and front output housing in a vice fitted with soft jaws gripping on the two flats of the viscous unit.
2. Using service tool 18G1205 to restrain the drive flange, release and remove the nyloc nut and plain washer securing the drive flange to the output shaft, withdraw the rubber seal. Discard the nut and seal.
3. Remove the drive flange from the viscous unit. Examine the flange for damage or wear particularly the seal running surface, if the surface is corroded or a groove has been worn by the previous seal discard the flange.

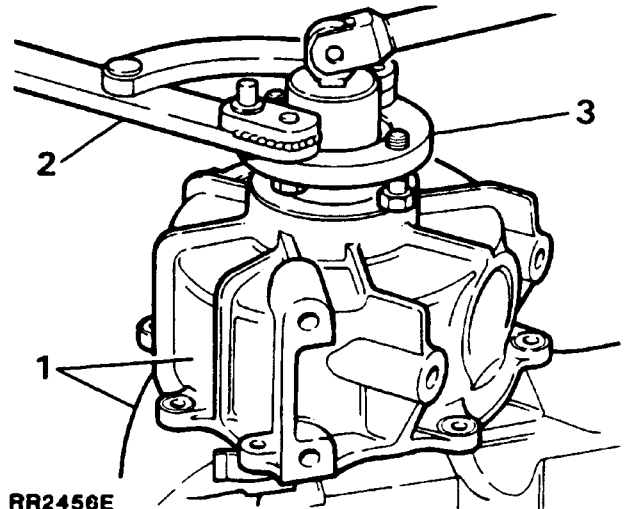
**RR2450E**

4. If necessary the oil catcher can be carefully pressed from the drive flange, if either a new oil catcher or bolts are being fitted.

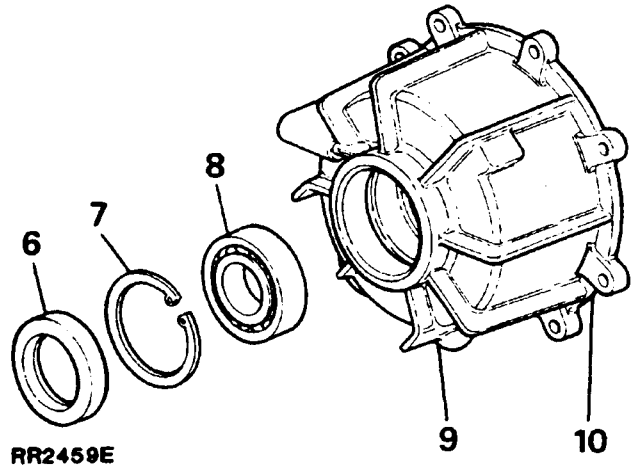
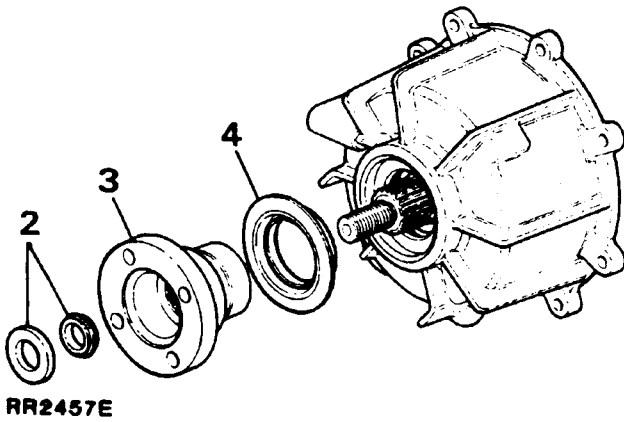

5. Carefully tap the viscous unit out of the housing. If the original unit is being refitted wipe clean with a clean cloth.

11. Examine the housing for damage and wear, renew the housing if necessary.

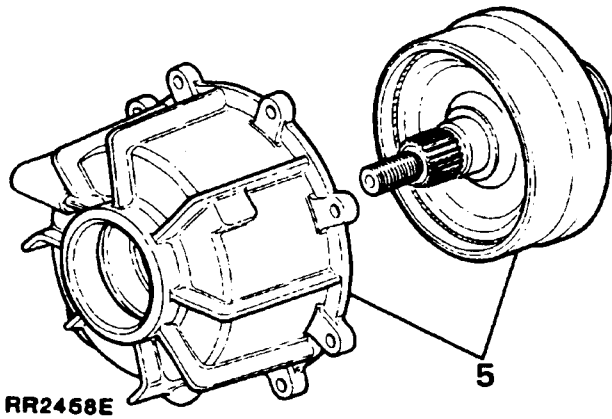

Front output housing - Assemble

- NOTE: The viscous unit is a sealed assembly and cannot be further dismantled, a new unit should be fitted if the unit is damaged or if the torque to turn is out of limits.**
6. Prise the oil seal out from the front output housing and discard.
 7. Remove the circlip retaining the bearing.
 8. Drive or press the bearing from the housing and discard.
 9. Clean the housing with a suitable solvent.
 10. Remove any previous sealant from the joint face of the housing.

12. Drive or press a new bearing into the housing
13. Fit the circlip to retain the bearing.
14. Lubricate a new oil seal. Using oil seal replacing tool 18G1422 fit the seal, lip side of the seal leading until it contacts the circlip.
15. Carefully tap the original or new viscous unit into the housing until contact is made with the face of the bearing.
16. Lubricate the lips of the seal and fit the flange followed by a new rubber seal; fit the steel washer and secure the flange with a new nut. Tighten to the specified torque.
17. Apply Dow Corning 732 or a suitable equivalent silicone sealant to the output housing joint face of the main casing. Evenly spread the sealant on the face to ensure a good seal.
18. Fit the housing to the main casing and secure in position with the eight bolts tightened evenly to the specified torque.
19. Refit the gearbox to the vehicle. (Refer to transfer gearbox remove and refit).

37 LT77 FIVE SPEED GEARBOX

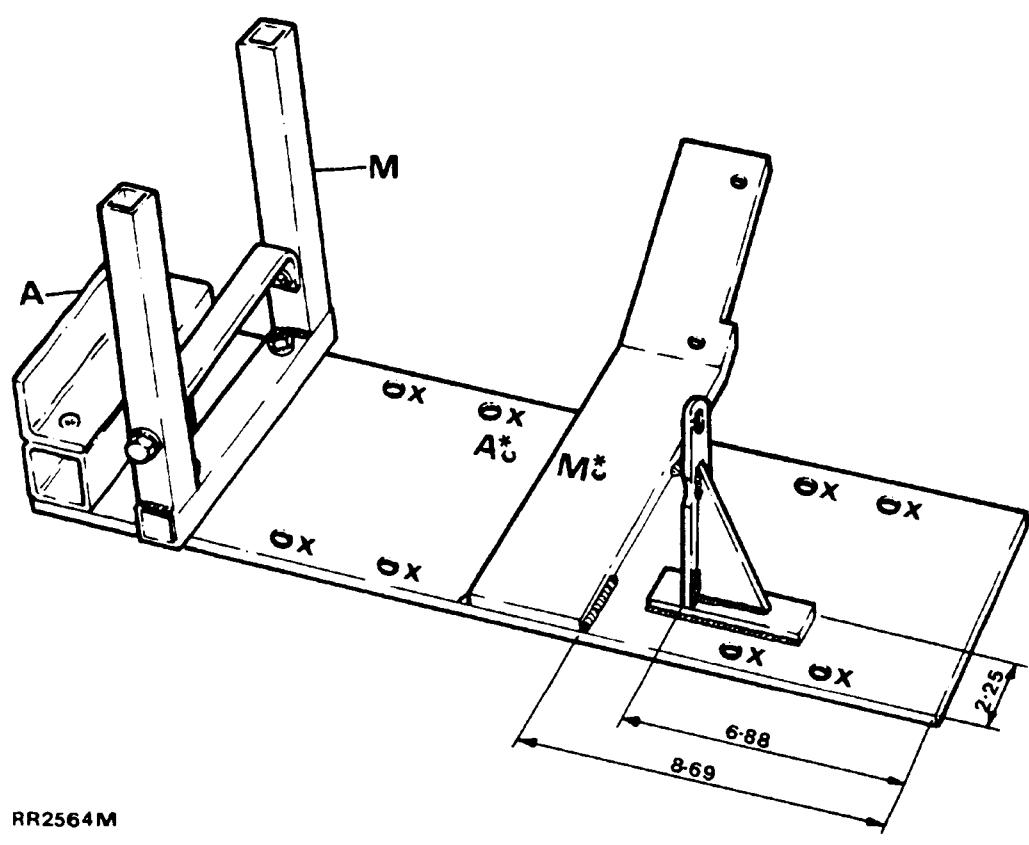

RR2564M

- A: Automatic gearbox models
- M: Manual gearbox models
- A*: Centre of lifting hoist(automatic models)
- M*: Centre of the lifting hoist (manual models)
- X: Drill fixing holes to suit hoist table

Material: Steel plate BS1449 Grade 4 or 14.

Preparation-under bonnet

1. Install the vehicle on a ramp and chock the wheels.
2. Disconnect the battery negative lead.
3. Release and remove the fan blade assembly. Note that the nut securing the viscous unit has a left hand thread, released by turning clockwise when viewed from the front.
4. **Fuel injection models** - Disconnect the airflow meter to plenum chamber hose.
5. **Carburettor models only** - Remove the air cleaner from its location.

Inside vehicle

6. Remove the main gear lever knob, select low range and remove transfer gear lever knob.

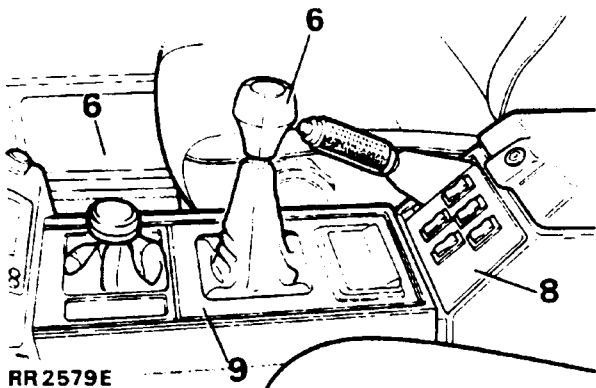

7. Release four screws and remove the glove box liner.
8. Carefully prise the window lift switch panel from the front of the glove box. Push the panel complete with switches back through the panel aperture and place on transmission tunnel.

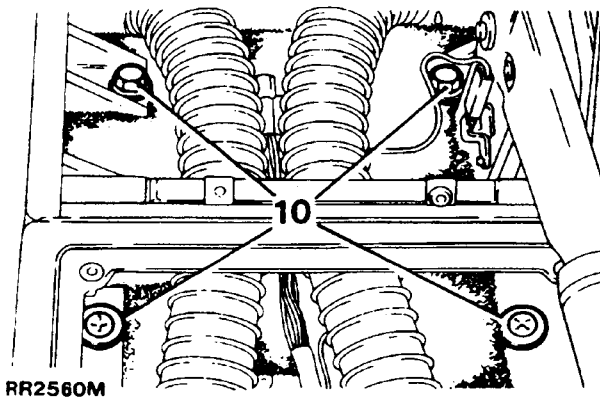

9. Carefully prise the centre panel around the main gear lever out of the floor mounted console.
10. Release the two bolts and two screws securing the glove box/console assembly to the transmission tunnel.
11. Detach the two relay blocks from their mounting inside the glove box.
12. Disconnect the leads to the rear cigar lighter.
13. Release the handbrake, pull the gaiter forward to gain access to the clevis pin. Remove split pin, washer and clevis pin to release inner cable from handbrake lever.
14. Carefully manoeuvre the glove box assembly rearwards (while raising the handbrake lever to its uppermost position) away from the radio housing and remove the glove box assembly from the vehicle.
15. Remove the sound deadening pad from the top of the transmission tunnel.
16. Slacken the pinch bolt and remove the upper gear lever.
17. Remove the screws and detach the high low lever and main gearlever retaining plates.

Underneath vehicle

18. Raise the ramp.
19. Place a suitable container under the transmission, remove the transfer gearbox, main gearbox and extension housing drain plugs, allow the oil to drain and refit the plugs. Clean the filter on the extension housing plug before refitting.

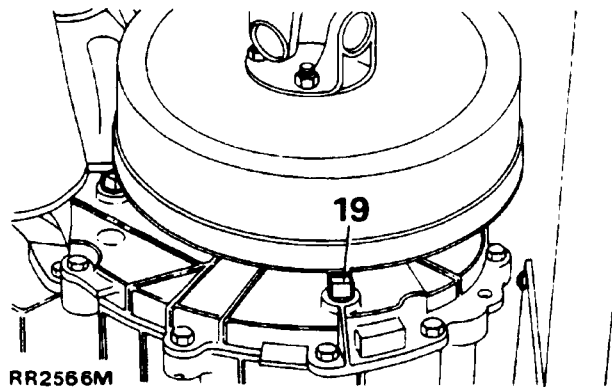

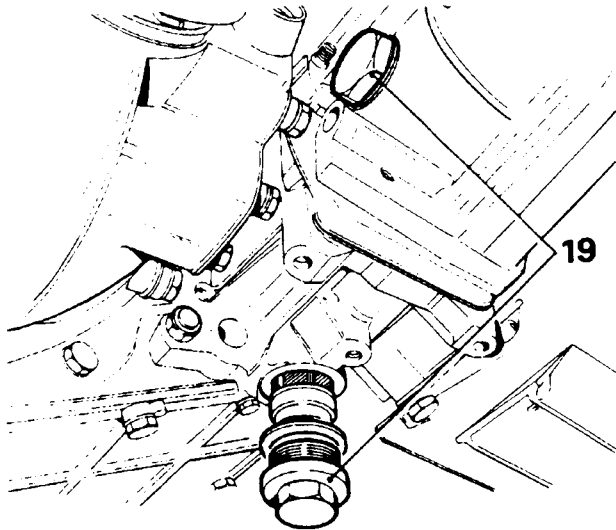

RR2565M

20. Remove the eight nuts and bolts securing the chassis cross member and remove the cross member. Use a suitable means of spreading the chassis, if necessary.
21. Remove the front exhaust downpipes and intermediate pipe with centre silencer.

NOTE: Operation 21 will require the assistance of a second operator to support the exhaust system while the fixings are released.

22. Mark each drive flange for reassembly and disconnect the front and rear propeller shafts from the transfer box. Tie the shafts to one side.
23. Release the clamp and disconnect the speedometer cable from the rear output housing, also free the cable from its clip at the left hand side of the transfer gearbox. Tie the cable to one side.
24. Remove the two bolts and withdraw the clutch slave cylinder from the bell housing.

Remove the transmission assembly

WARNING: Where the use of a transmission hoist is necessary, it is ABSOLUTELY ESSENTIAL to follow the hoist manufacturer's instructions to ensure safe and effective use of the equipment.

25. Position a suitable transmission hoist on the rear output housing or brake drum to support the weight of the transmission assembly.
26. Remove the fixings and withdraw the transfer gearbox mountings.

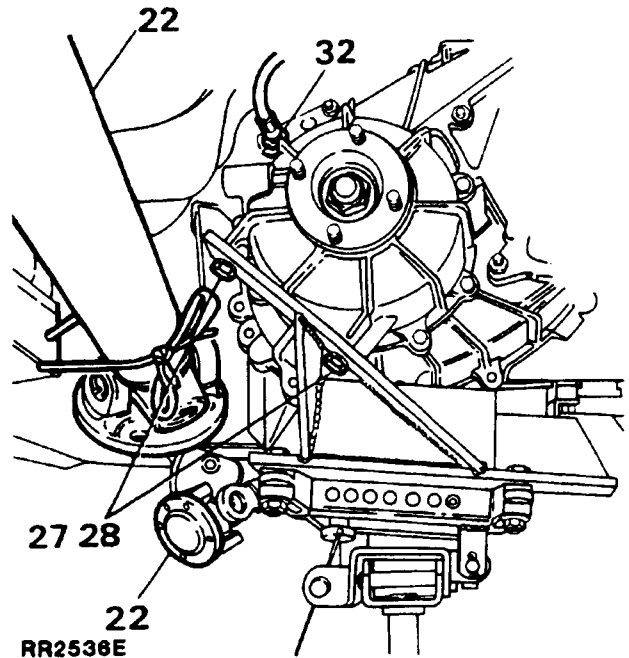

RR2536E

27. Secure the previously manufactured fixture to a transmission hoist, raise the hoist and position the fixture under the transfer box mounting points.
28. Secure the fixture to the transfer box mounting points using the original mounting bolts.
29. Remove the transmission hoist from the rear of the transfer box.
30. Carefully lower the transmission until the top of the transfer gearbox clears the rear passenger floor.
31. Disconnect the handbrake cable by removing the split pin, washer and clevis pin.
32. Remove the clip securing the handbrake outer cable to the support bracket, feed the cable through the bracket, and tie cable to one side.
33. Position the transmission hoist under the engine to support the weight while removing bellhousing bolts.
34. Remove the bolts from the bell housing.
35. Ensuring all connections to the engine and chassis are released, withdraw the transmission.

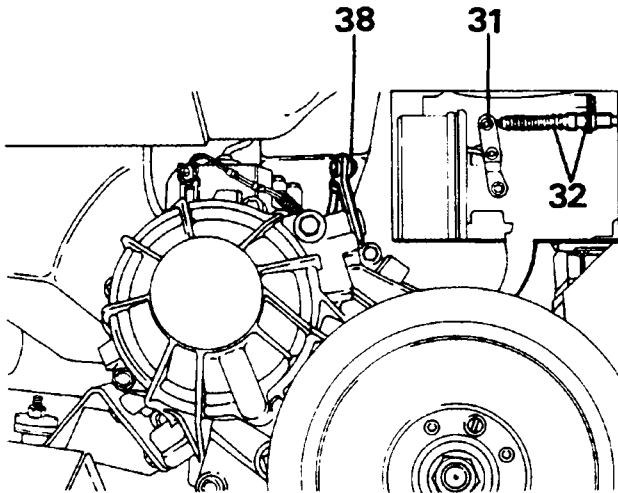

RR2558E

Separating the transfer box from gearbox

36. Remove the transmission assembly from the hoist and cradle and install it safely on a bench.
37. Place a sling round the transfer box and attach to a hoist.
38. Detach the high low link from the transfer gearbox selector lever and remove the breather pipe.
39. Remove the upper and lower bolts and two nuts retaining the transfer box to the extension housing and withdraw the transfer box.

Assembling transfer box to main gearbox

40. Stand the gearbox vertically on the bell housing face on two pieces of wood to prevent damage to the primary pinion which protrudes beyond the bell housing face. Lower the transfer gearbox onto the main gearbox, care should be taken to prevent any damage to seals. Secure the transfer gearbox to the main gearbox and tighten all bolts to the correct torque.
41. Refit the breather pipe and selector link.

Transfer gearbox high/low link adjustment

42. Ensure that the selector lever at the transfer gearbox is in the neutral position.
43. Set the transfer gearbox lever in a vertical position (at right angles to the centre line of the main gearbox). Rotate the fork end of the rod until the holes align with the hole in the selector lever.
44. Fit the clevis pin and retaining clip. Select high and low transfer to ensure full engagement is obtained. Repeat the adjustment procedure if full engagement is not evident.

Refitting

45. Fit the cradle to the transmission hoist and the transmission to the cradle. Smear Hylomar on bell housing mating face with engine.
46. Select any gear in the main and transfer gearbox to facilitate entry of the input shaft. Ensure that the clutch centre plate is in alignment.
47. Position and raise the hoist to line up with the engine, feed the handbrake cable through the aperture in the tunnel, ensure that any pipes or electrical leads do not become trapped.
48. Fit the transmission assembly to the engine and tighten the securing bolts.
49. Reverse the removal procedure noting the following points.
50. Tighten all fixings to the correct torque.
51. Check that the three drain plugs are tight and remove the main gearbox and transfer box filler level plugs. Fill both the main and transfer gearboxes with the recommended oil up to the level of the filler hole. Apply Hylomar sealant to the threads and fit the level plugs and wipe away any surplus oil.
53. Finally road test vehicle.

LT77 FIVE SPEED GEARBOX

OVERHAUL

The following overhaul procedure covers existing gearboxes and also the latest modified version. Improvements include increased capacity layshaft bearings and a new upper gearlever and gear knob. These modifications will improve durability and gearchange quality.

NOTE: Modified gearboxes are identified by the serial number prefix 'F'.

Service Tools:

- 18G705 - Puller - Bearing remover
- 18G705 - 1A - Adaptor for mainshaft
- 18G705 - 5 - Adaptor for layshaft
- 18G705 - 7 - Adaptor for layshaft - increased capacity bearings
- 18G1400 - Remover for synchromesh hub and gear cluster
- 18G1400 - 1 - Adaptor mainshaft fifth gear
- MS47 - Hand press
- 18G47BA - Adaptor, input shaft bearing
- 18G47BAX - Conversion kit
- 18G284 - Impulse extractor
- 18G284AAH - Adaptor for input shaft pilot bearing track
- 18G1422 - Mainshaft rear oil seal replacer
- 18G1431 - Mainshaft fifth gear and oil seal collar replacer
- 18G1205 - Flange holder

Locally manufactured tools

In addition to the service tools, the following items should be manufactured locally to facilitate overhauling the gearbox.

- A. Dummy centre bearing, used for selection of first gear bush, material mild steel.

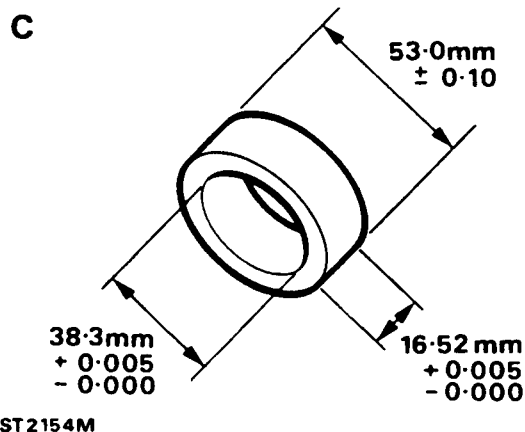

- B. Reverse shaft/layshaft fifth gear retainer, used to prevent reverse shaft falling out of gearcase during overhaul, also used to prevent layshaft fifth gear rotation when removing/refitting stake nut. Manufacture using 5mm mild steel. A suitable spacer 20mm diameter, 23mm long with a 8mm diameter hole is required when retaining layshaft fifth gear.

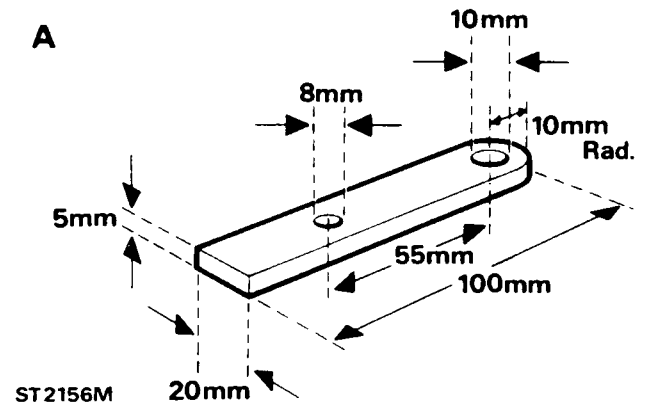

- C. Pilot studs, 4 off, threaded 8mm, used when separating centre plate from main gearcase.

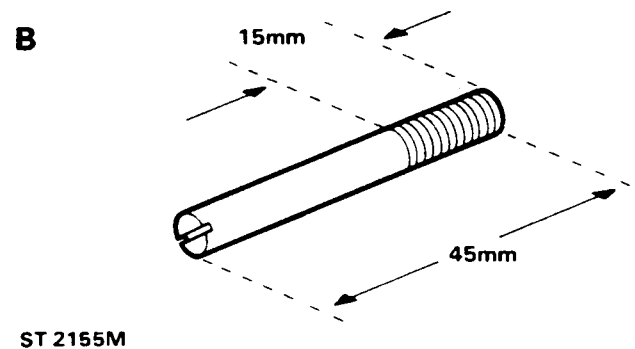

- D. Layshaft support plate is fitted using two 8 x 25mm bolts and washers to the front of the gearbox case, it also supports the input shaft bearing outer track.

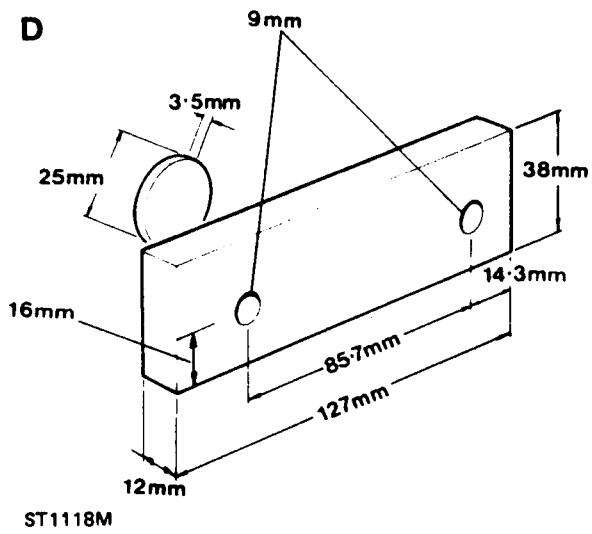

Continued

37 LT77 FIVE SPEED GEARBOX

E. Gearbox workstand, securely locates gearbox unit during overhaul. Manufacture from 30mm x 30mm angle iron. Plan view of top is half scale. Gearbox security hole (A) is drilled 10mm through material. Four countersunk holes (B) are for gearbox location. Countersink using a 10mm drill, DO NOT drill through material.

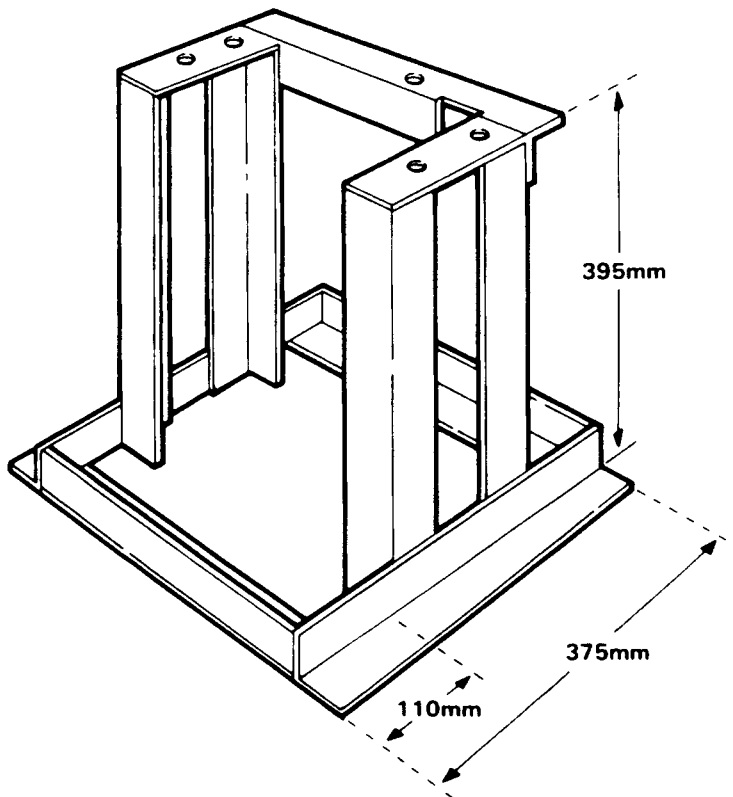
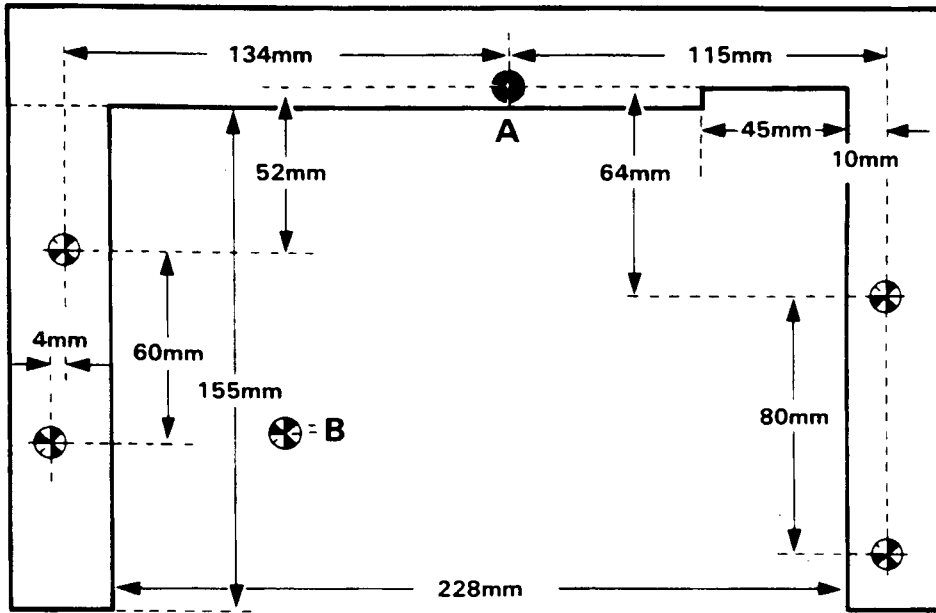

ST2153M

Dismantle

1. Place gearbox on a bench with the transfer gearbox removed, ensuring the oil is first drained. Thoroughly clean the exterior of the gearbox case:
2. Remove the two pan head screws securing the gear change housing top cover. Raise the cover to give access to the gear change housing to extension case securing bolt adjacent to the reverse plunger assembly, and remove the bolt.
3. Remove the three remaining gear change housing to extension case securing bolts, remove the housing complete with transfer gear change assembly.
4. Remove the clutch release bearing plastic staple and remove the clutch release bearing.

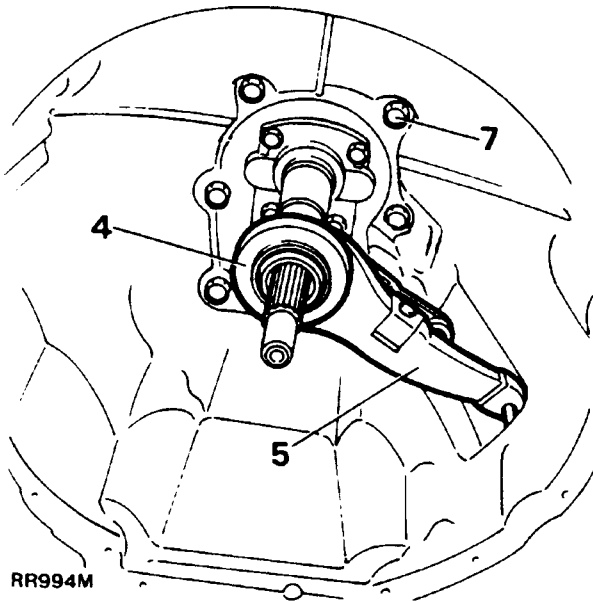

5. Release the single bolt and remove the spring clip from the clutch release lever. Pull the lever off the clutch release pivot.
6. If necessary: Remove the clutch release pivot and single bolt retaining the clutch release bearing guide. Withdraw the guide from the input shaft.

7. Remove the six bolts and washers securing the bell housing.
8. Carefully ease the bell housing off the dowels and withdraw it from the gearbox.
9. Remove two dowel tubes from the front of the casing and secure the gearbox unit to the workstand by one nut and bolt.

Extension housing

1. Remove the circlip which retains the mainshaft oil seal collar located at the rear of the gearbox. Using tools 18G705 and 18G705 - 1A remove the oil seal collar.

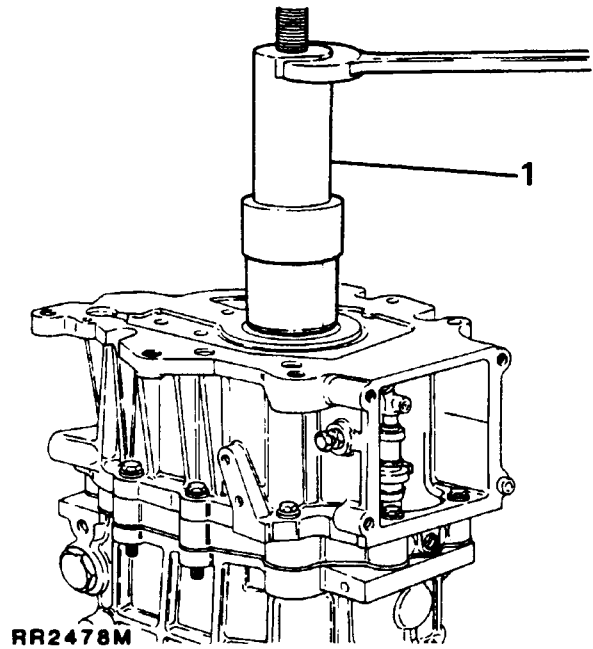

2. Remove the ten bolts and spring washers securing the fifth gear extension case to the gearcase. Carefully withdraw the extension case ensuring that the centre plate does not separate from the main case. Discard the gasket.

Continued

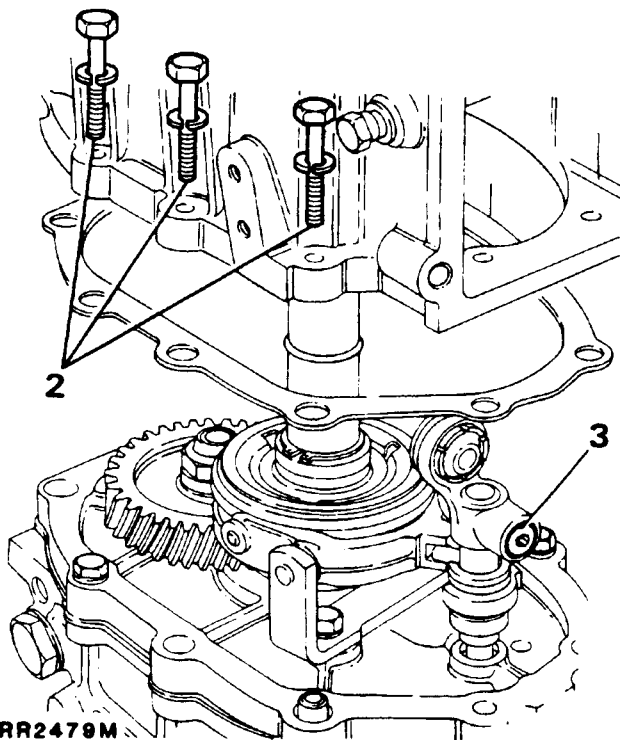

RR2479M

3. Slacken the socket head screw and remove the selector yoke from the selector shaft.

Fifth gear

1. Fit two slave bolts (8 X 35 mm) to the casing to retain the centre plate to the main case.
2. Remove the oil seal collar 'O' ring from the mainshaft.
3. Withdraw the oil pump drive shaft.
4. Remove the two 'E' clips from the selector fork pivot pins retaining the 5th selector fork to its bracket and remove the pins, fork and pads.
5. Withdraw the fifth gear selector spool.
6. Remove the two bolts and spring washers and withdraw the fifth gear selector fork bracket.
7. Secure the flange holder 18G1205 to left hand side of gearcase.
8. Bolt the layshaft fifth gear retainer to the gearcase using the spacer. Insert a suitable length of bar, or a 10 mm bolt, through pierced hole in gear to prevent rotation.

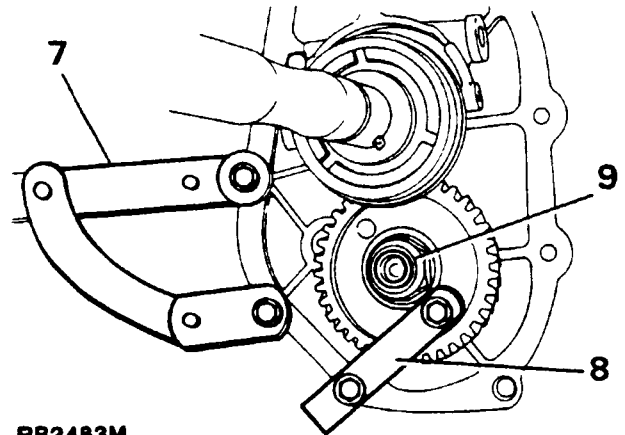

RR2483M

9. De - stake the nut securing fifth layshaft gear and remove the nut.
10. Release the circlip retaining the fifth gear synchromesh assembly to the mainshaft.
11. Using tools 18G1400 - 1 and 18G1400 withdraw the selective washer, fifth gear synchromesh hub and baulk ring, fifth gear (driven), spacer and split roller bearing from the mainshaft.

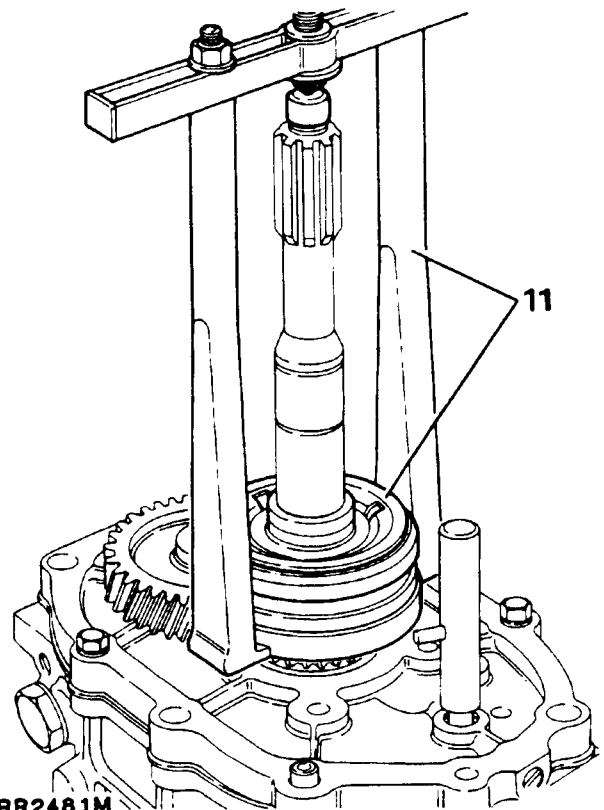

RR2481M

12. Using tools 18G705 and 18G705 - 1A, remove the layshaft fifth gear.

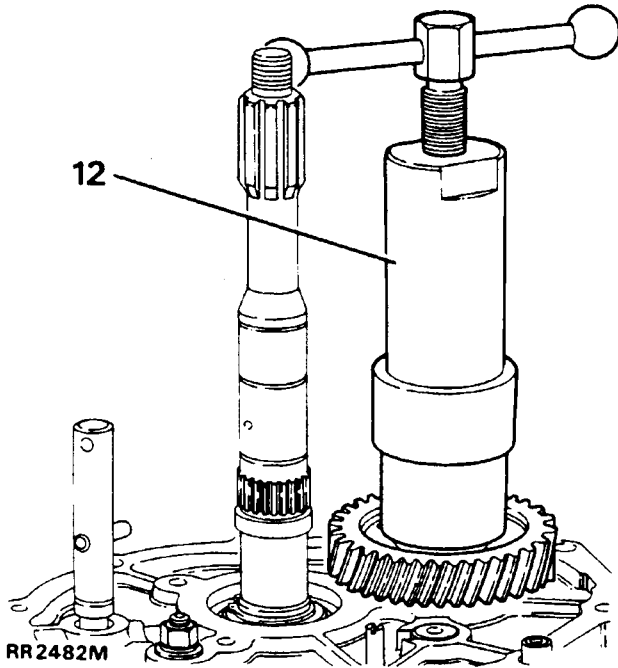

Main gearbox case

1. Fit the reverse shaft retainer using one of the fifth gear bracket mounting bolts. Fit the four guide studs to the main gearbox case to locate in the workstand.

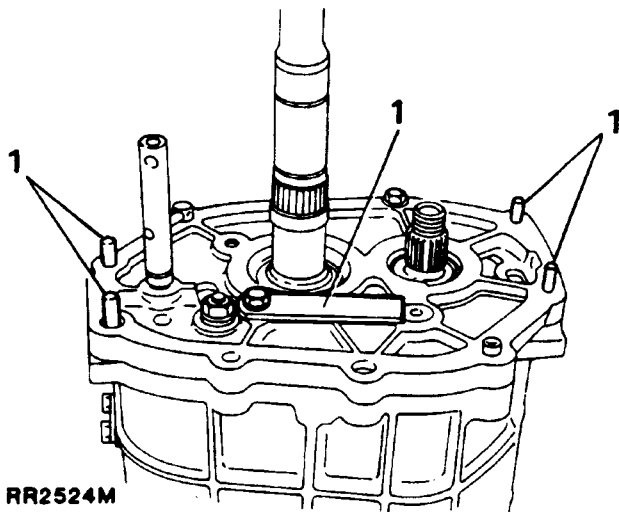

2. Release the gearbox from the workstand, invert the assembly and locate the four studs on the workstand.

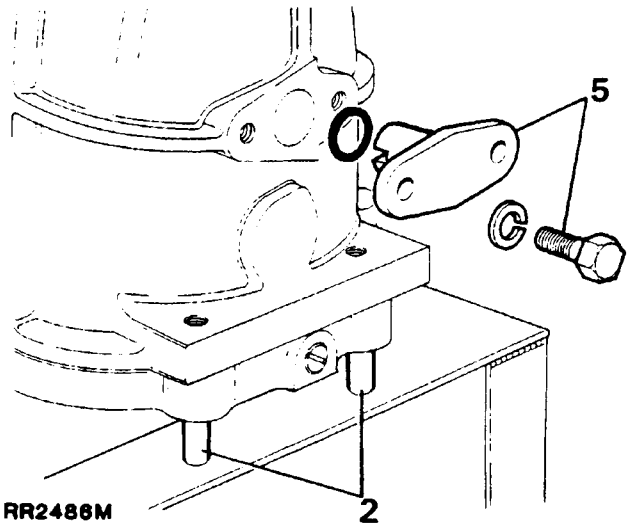

3. Remove the six bolts and spring washers from the front cover, withdraw the cover and discard the gasket.
 4. Retrieve the input shaft and layshaft selective washers from the gearcase.
 5. Remove the two bolts and washers and withdraw the retainer for the selector shaft front spool. Note that later models have an 'O' ring with a counterbore in the gearcase.

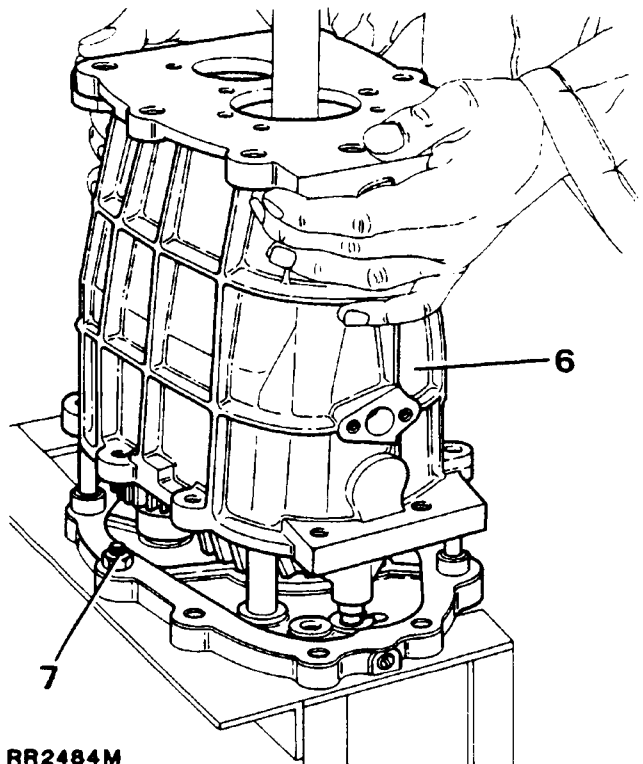

6. Remove the slave bolts and carefully lift the gearcase, leaving the centre plate and gear assemblies in position.

7. Secure the centre plate to the workstand with a nut and bolt when the plate and casing have separated. Discard the gasket.

Reverse shaft, layshaft and mainshaft

1. Release the reverse shaft retainer and remove the shaft.
2. Lift off the thrust washer, reverse gear and spacer from the centre plate.
3. Remove the pivot pin securing the reverse lever without removing the 'E' clip.
4. Remove the reverse lever and slipper pad.

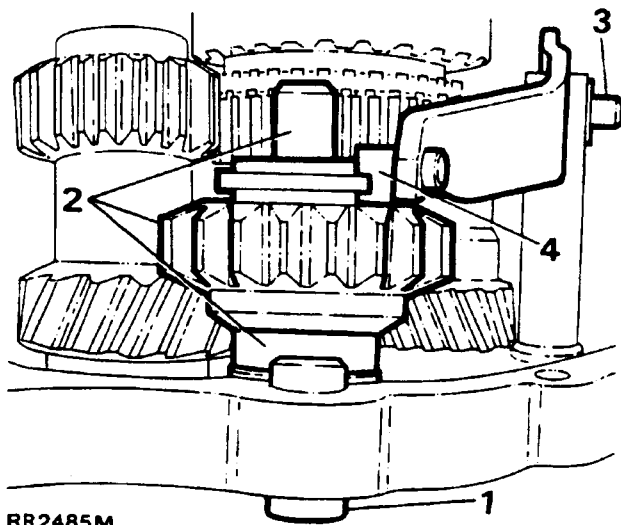

RR2485M

5. Remove the input shaft and fourth gear baulk ring.
6. Withdraw the selector plug, spring and detent ball from the centre plate.
7. Lift off the layshaft cluster by tilting it away from the mainshaft, simultaneously lifting the mainshaft slightly to clear the rear layshaft bearing.
8. Rotate the fifth gear selector shaft anti-clockwise (viewed from above) to align the fifth gear selector pin with the slot in the centre plate.

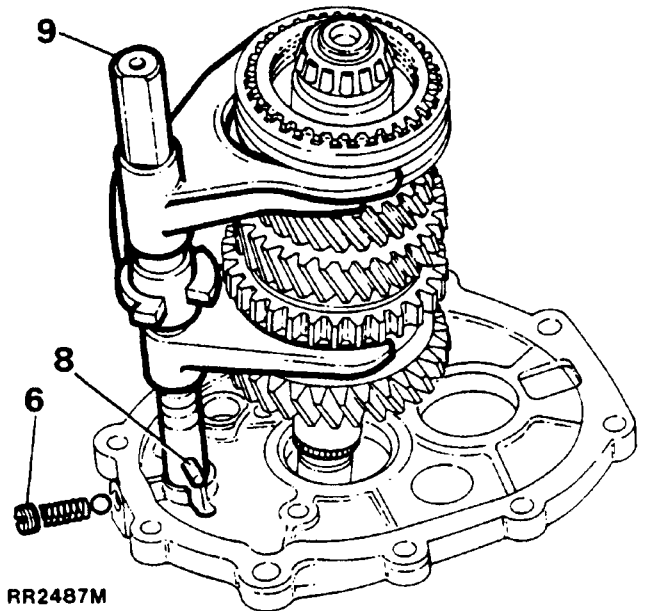

RR2487M

9. Remove the mainshaft and selector fork assemblies from the centre plate together.
10. Detach the selector fork assembly from the mainshaft gear cluster.
11. Remove the nut and bolt and release the centre plate from the workstand.

Layshaft

12. Using press 18G705 and tool 18G705 - 5 (18G705 - 7 if the increased capacity bearings are fitted) remove the layshaft bearings.

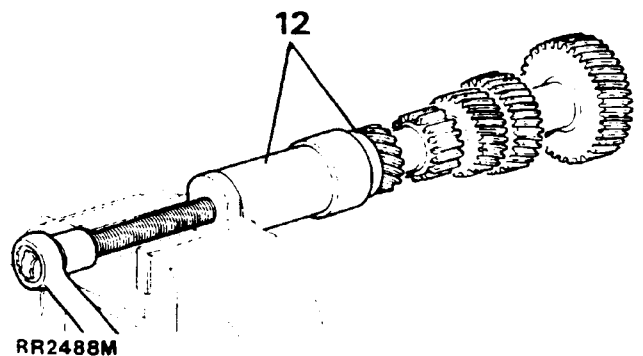

RR2488M

Mainshaft

13. Remove the centre bearing circlip.
14. Using press MS47 and two suitable metal bars to support first gear, remove the centre bearing, first gear bush, first gear and needle bearings and first gear baulk ring.

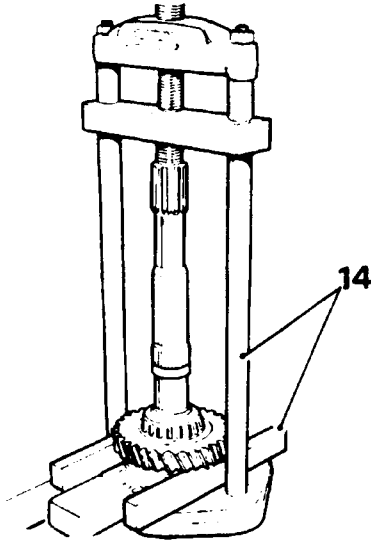

RR2489M

15. If a difficulty is experienced in removing the first and second gear synchromesh hub, support the second gear with the bars, and operate the press to release the first/second synchromesh unit, second gear, baulk ring and needle bearings.
16. Turn the mainshaft through 180° and repeat the operation using press MS47 and a suitable extension. Support third gear, press the mainshaft through the pilot bearing spacer, third and fourth synchromesh unit, third gear baulk ring, third gear and needle bearings.

INSPECT AND PREPARE FOR REBUILDING

NOTE: It is essential that all components are thoroughly cleaned and inspected before the rebuild is commenced. During the rebuild it is recommended that new bearings are fitted.

Main gearbox casing

1. Remove the mainshaft and layshaft bearing tracks from the main casing.
2. Remove the plastic oil trough from the front of the casing.
3. Clean gearcase thoroughly using a suitable solvent. Inspect case for cracks, stripped threads in the various bolt holes, and machined mating surfaces for burrs, nicks or any condition that would render the gearcase unfit for further service. If threads are stripped, install Helicoil, or equivalent inserts.
4. Insert a new plastic oil scoop inside the front of the casing, ensuring that the scoop side faces the top of the casing.

Front cover

1. Remove and discard the oil seal from the front cover. Do not fit a new oil seal at this stage.

Centre plate

1. Remove the layshaft and mainshaft bearing tracks from the centre plate. If required remove the reverse pivot post.
2. Inspect the bearing plate for damage and check the selector rail bore hole for wear.

Continued

37 LT77 FIVE SPEED GEARBOX

Extension case

1. Examine the extension case for obvious signs of damage to threads and joint faces.
2. Remove the three oil pump housing bolts, spring washers and oil pump gears and housing. Inspect gears, renew if necessary
3. Do not withdraw oil pick - up pipe.
4. Remove the plug, washer and filter.
5. Ensure that the oil pick - up pipe is free of contamination or blockage.
6. Invert casing and extract the oil seal.
7. Press out the ferrobestos bush from the casing.

WARNING: This component contains asbestos DO NOT use an air line when cleaning, as breathing asbestos dust is dangerous to your health. Use methylated spirit or denatured alcohol to clean asbestos components.

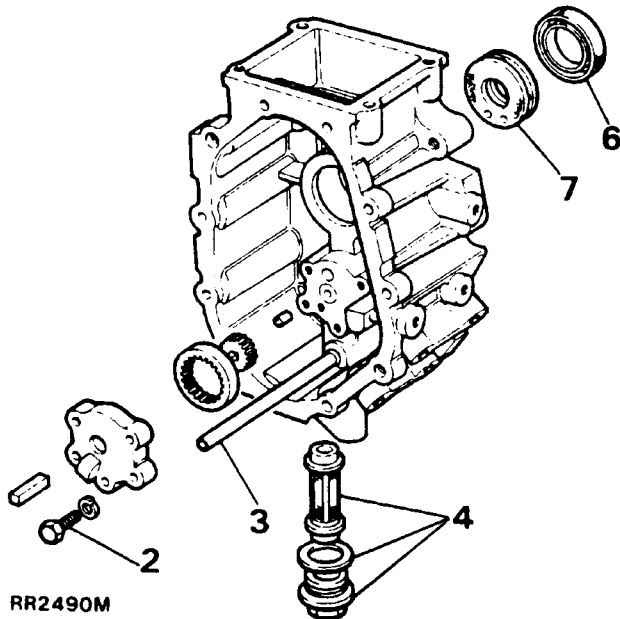

8. Press a new ferrobestos bush fully into position, ensuring the two drain holes are towards the bottom of the case.

NOTE: If a new extension case is fitted, it is essential that a grub screw is securely fitted in the main oilway located in the rear of the case.

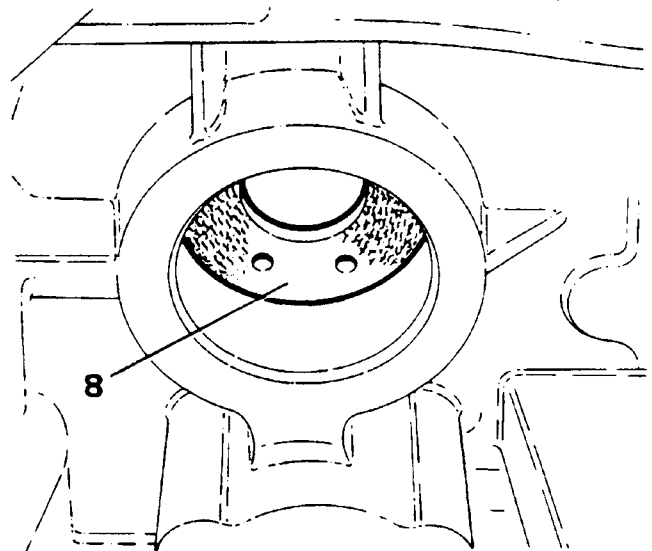

RR2491M

9. With the aid of tool 18G1422, fit a new oil seal to the rear of the extension case. Ensure the seal lips are towards the ferrobestos bush. Lubricate the seal lips with a suitable SAE 140 oil.
10. Assemble and fit the fibre oil pump gears to the oil pump cover, whilst ensuring the centre rotor square drive faces the layshaft.
11. Fit the three bolts and spring washers to secure the oil pump cover, and tighten to the correct torque.
12. Fit a new oil filter, fibre gasket and tighten plug to the correct torque.

Gear change housing

NOTE: The upper and lower gear levers are loctited together on vehicles produced from late 1985 onwards. If difficulty is experienced in separating these two components, a complete new assembly should be fitted.

LATER VEHICLES: To eliminate this problem a new upper gear lever, using a pinch bolt fixing to lower lever, is now fitted. The top of the lower gearlever is grooved to locate upper lever pinch bolt.

1. Release the single bolt with plain washer securing the reverse plunger to the gear change housing.
2. Withdraw the plunger and retain the shims.

3. Remove the two bolts and washers anchoring the bias springs.
4. Release the springs from the register at the gear lever and remove them from the dowels. Restrain the springs using suitable grips whilst releasing bolts.
5. Remove the remaining two bolts securing the bias adjustment plate to the housing.
6. Remove the lower gear lever and bias plate from the housing.
7. Check the security of the spool guide bolts, located on the underside of the gear change housing.
8. Prise the seal from the bottom of the gear change housing.
9. Examine the gear change housing, ensuring that the cross pin location slots are not worn.
10. Inspect the condition of the bias springs renew if necessary.

11. Fit a new seal to the bottom of the housing, lips of the seal uppermost.
12. Lightly grease the lower gear lever ball with Shell Alvania R3.
13. Fit a new railko bush.
14. Fit the assembly to the housing locating the two pegs on the ball in the recesses of the ball seat.
15. Locate the bias adjustment plate, coat two of the retaining bolts with Hymolar PL32 or Loctite 290 and fit them forward of the gear lever. Do not tighten the bolts at this stage.
16. Fit the springs onto the posts, coat the remaining two bolts with Hylomar PL32 or Loctite 290 and fit to the housing to secure the springs in position. Do not tighten the bolts at this stage.
17. Carefully lever the free end of the springs around the rear of the gear lever until they are retained by the stop on the adjustment plate.
18. Do not fit the top cover at this stage.

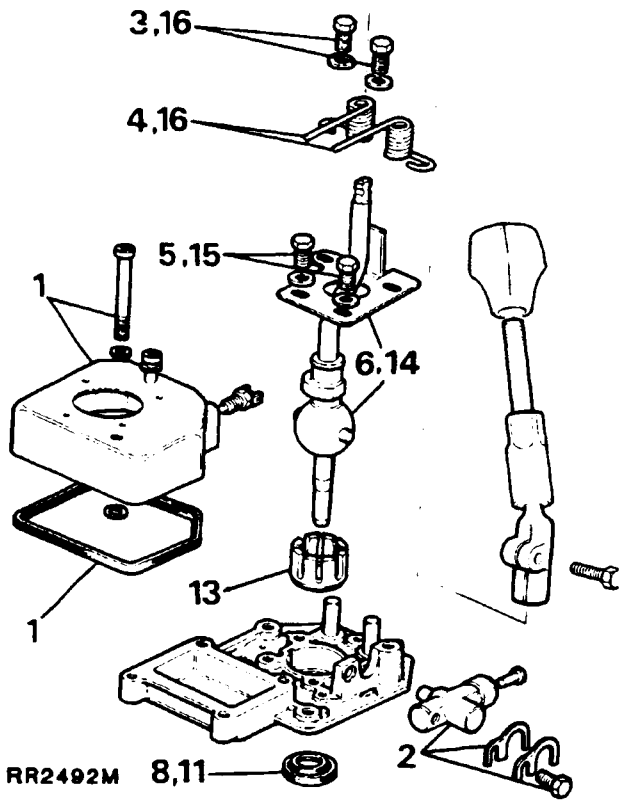

Reverse gear plunger assembly

NOTE: The plunger assembly is not a serviceable item. To check that the unit is operating correctly proceed as follows.

1. Apply a load of between 45 to 55 kg (100 to 120 lb) to the plunger nose. If the plunger is operational within these limits the unit is satisfactory. If the plunger operates outside the limits renew the plunger assembly.

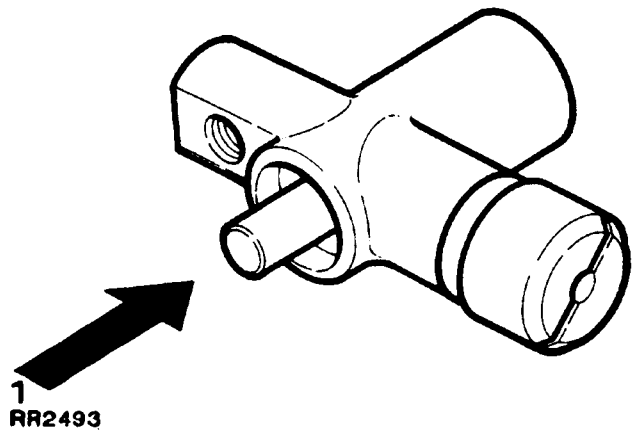

Continued

Synchromesh assemblies

1. Mark the hub and sleeve to aid reassembly. Lever the backing plate off the fifth gear synchromesh assembly. Remove the slipper springs from the front and rear of each synchromesh assembly.
2. Withdraw the slippers and hub from the sleeve.
3. Inspect the springs and slippers for wear or breakage, fit new components where necessary. Inspect all the synchromesh components and fit new parts if there is evidence of chipped teeth or excess wear.

NOTE: With the outer sleeve held, a push-through load applied to the outer face of the synchromesh hub should register 8,2 to 10 kgf m (18 to 22 lbf ft) to overcome the spring detent in either direction.

4. Assemble the first and second synchromesh assembly by locating the shorter splines on inner member towards the second gear. Note that the outer member selector fork groove is to the rear of the gearbox

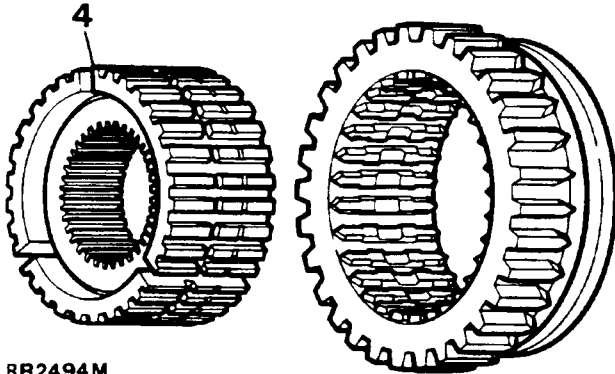

RR2494M

5. Refit the slippers and locate the slipper springs to each side of the assembly, ensuring that the hooked ends of both slipper springs are located in the same slipper, but running in opposite directions and fully located against the other two slippers.

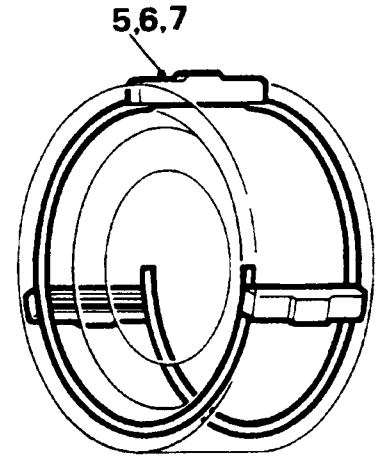

RR2495M

6. Assemble the third and fourth synchromesh assembly. Refit the slippers and locate the slipper springs to each side of the assembly, ensuring that the hooked ends of both slipper springs are located in the same slipper, but running in opposite directions and fully located against the other two slippers.
7. Assemble the fifth synchromesh hub assembly again ensuring the hooked ends of both slipper springs are located in the same slipper, but running in opposite directions. Fit the backplate onto the rear of the synchromesh hub assembly. Ensure the tag on the backplate locates in the slot on the hub.
8. Check the wear between all the baulk rings and gears by pushing the baulk ring against the gear and measuring the gap between the gear and baulk ring. The minimum clearance (earlier vehicles) is 0,64 mm (0.025 in). Molybdenum coated baulk rings are fitted to later boxes which may be used on all gears on any LT77 gearbox, in which case the minimum clearance is 0,38mm (0.015 in). If required clearance is not met, fit new baulk rings.

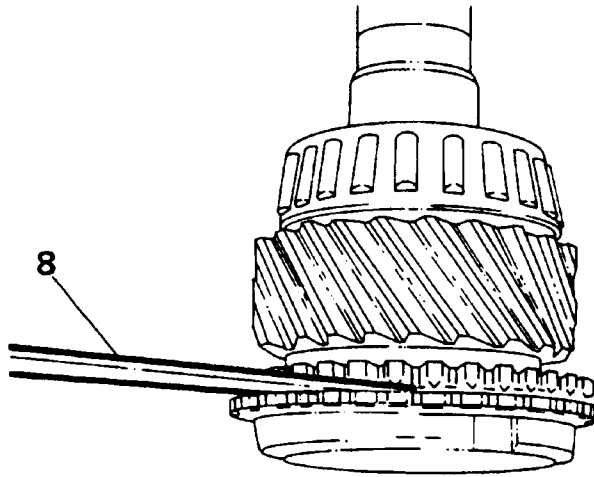

RR2496M

Input shaft

1. With the aid of tools 18G284AAH and 18G284, extract the pilot bearing track.
2. Using tools MS47 and 18G47BA, remove the input shaft bearing.

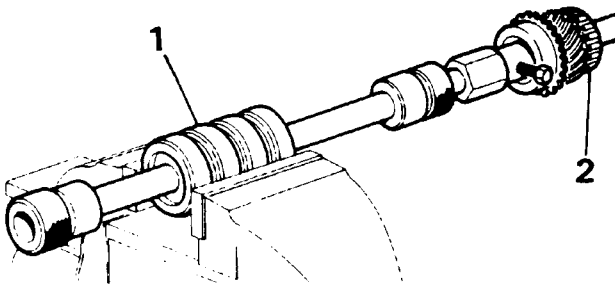

RR2497M

3. Inspect the shaft for wear or damage, and polish the oil seal track using fine emery cloth if required.
4. Using tool MS47 and a suitable tube, fit a new pilot bearing track to the input shaft.
5. Fit a new input shaft bearing using tools MS47, 18G47BA and 18G47BA - X.

Mainshaft

1. Examine each roller bearing surface for wear, and check the condition of the circlip grooves. Inspect the mainshaft splines, especially if any of the synchromesh units were found to be a loose fit during dismantling.
2. Ensure the oilways are free from sludge or contamination. Thoroughly clean with compressed air, observing the necessary safety requirements.
3. Check that the roll pins, pressed into the oil outlets to restrict oil flow to the bearings, are fitted below the bearing surface.

Mainshaft end float checks

Fifth gear

1. Fit the thrust washer, split roller bearing and fifth gear to the mainshaft, place a straight edge on the shoulder and using feeler gauges check the end float between gear and shoulder. End float should not be in excess of 0,20 mm (0.008 in) maximum. If end float is outside limit inspect the washer and gear faces for wear.

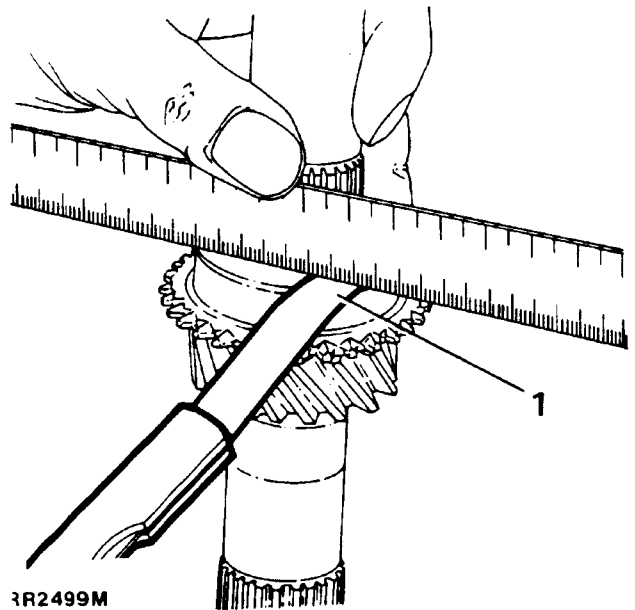

RR2499M

Continued

37 LT77 FIVE SPEED GEARBOX

- 1. MAIN GEARCASE
- 2. CENTRE PLATE
- 3. EXTENSION CASE
- 4. BELL HOUSING (Petrol models)
- 5. LAYSHAFT ASSEMBLY
- 6. REVERSE IDLER ASSEMBLY
- 7. OIL PUMP ASSEMBLY
- 8. BELL HOUSING (Diesel models)

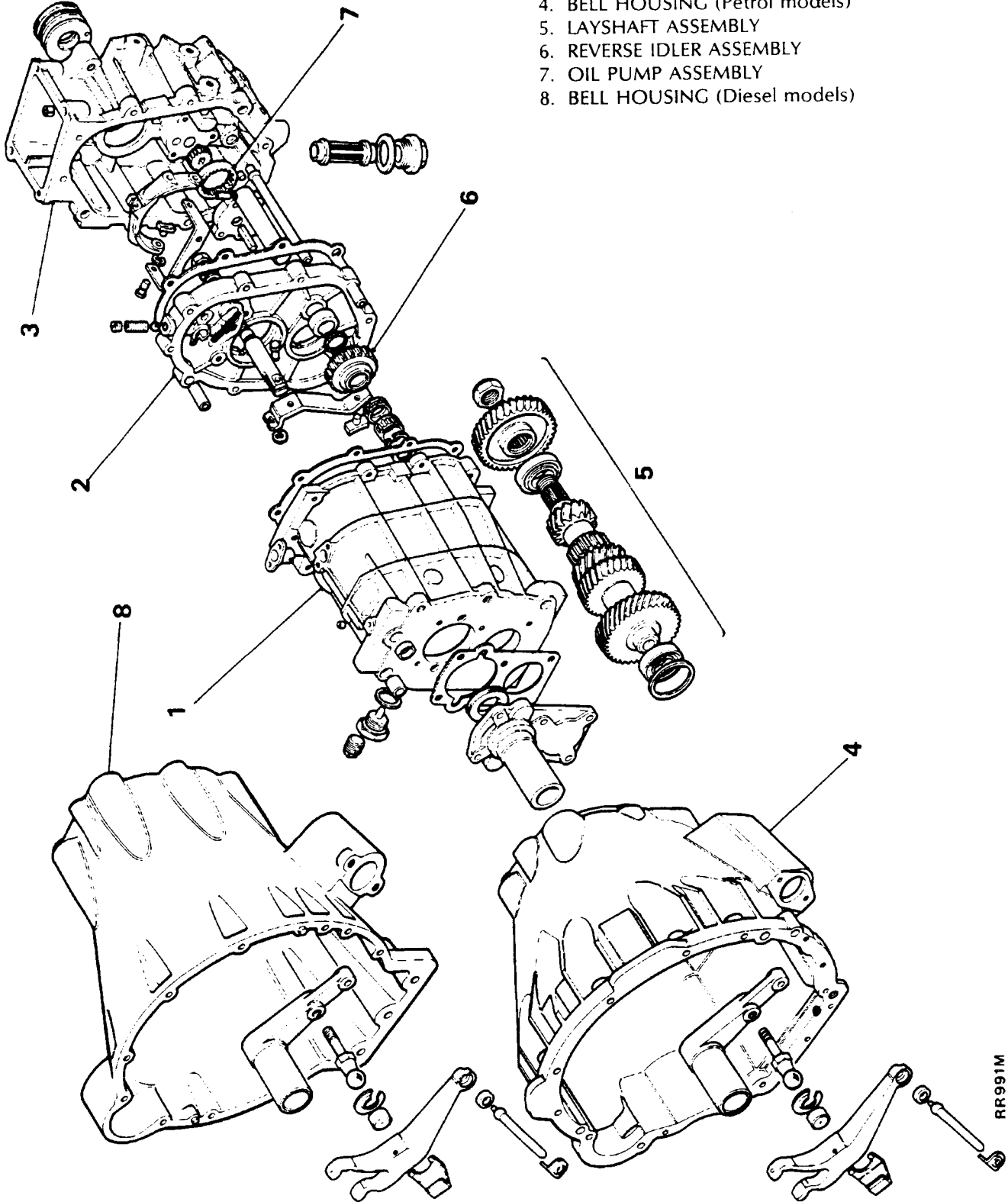

RR991M

- 9. MAINSHAFT AND GEAR ASSEMBLY
- 10. GEAR SELECTOR ASSEMBLY
- 11. PRIMARY PINION ASSEMBLY

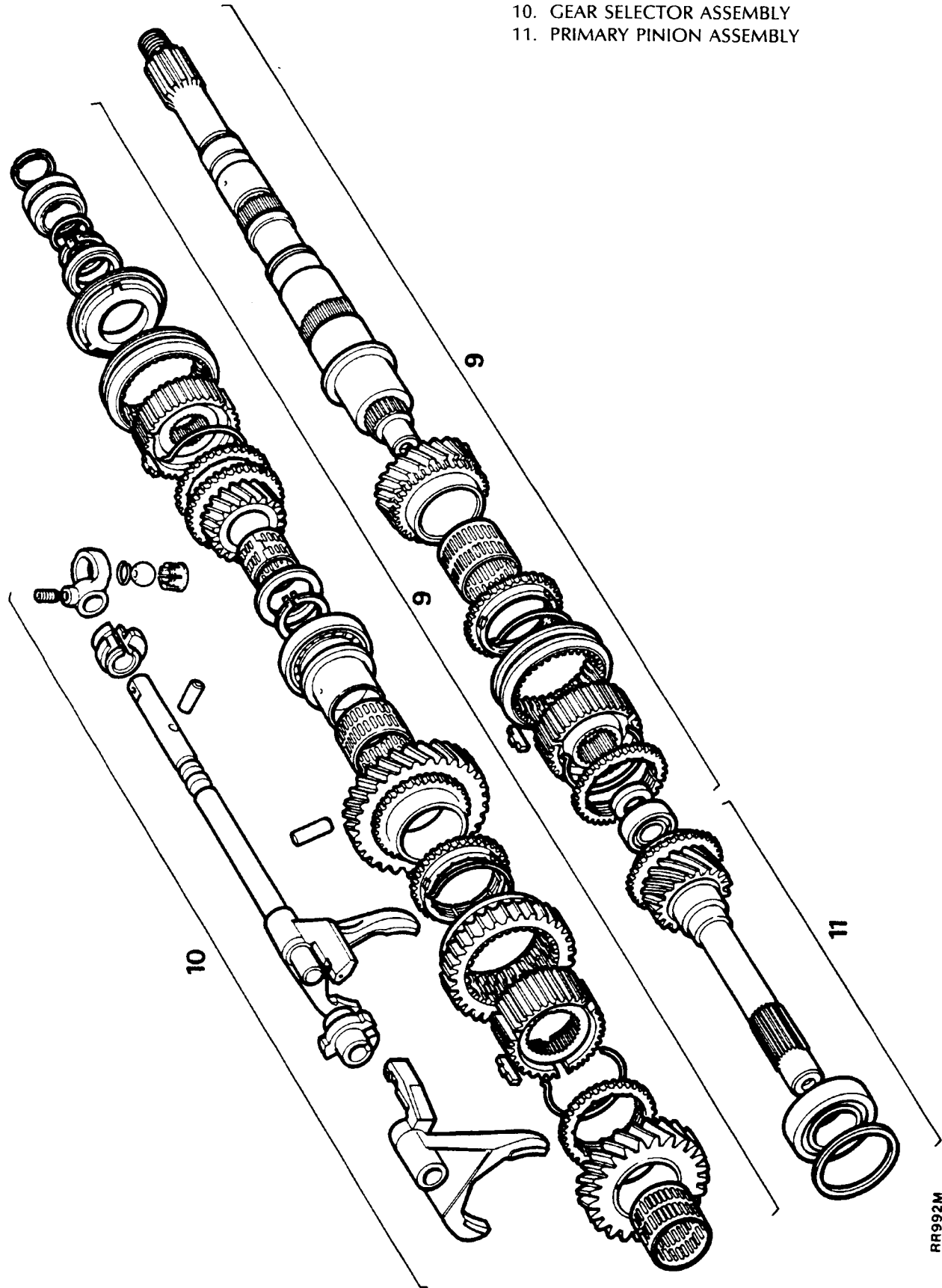

RR992M

37 LT77 FIVE SPEED GEARBOX

- 12. BIAS PLATE ASSEMBLY
- 13. UPPER GEAR LEVER ASSEMBLY
- 14. GEARBOX TOP COVER AND SEAL
- 15. LOWER GEAR LEVER AND BUSH
- 16. REVERSE PLUNGER AND SHIMS

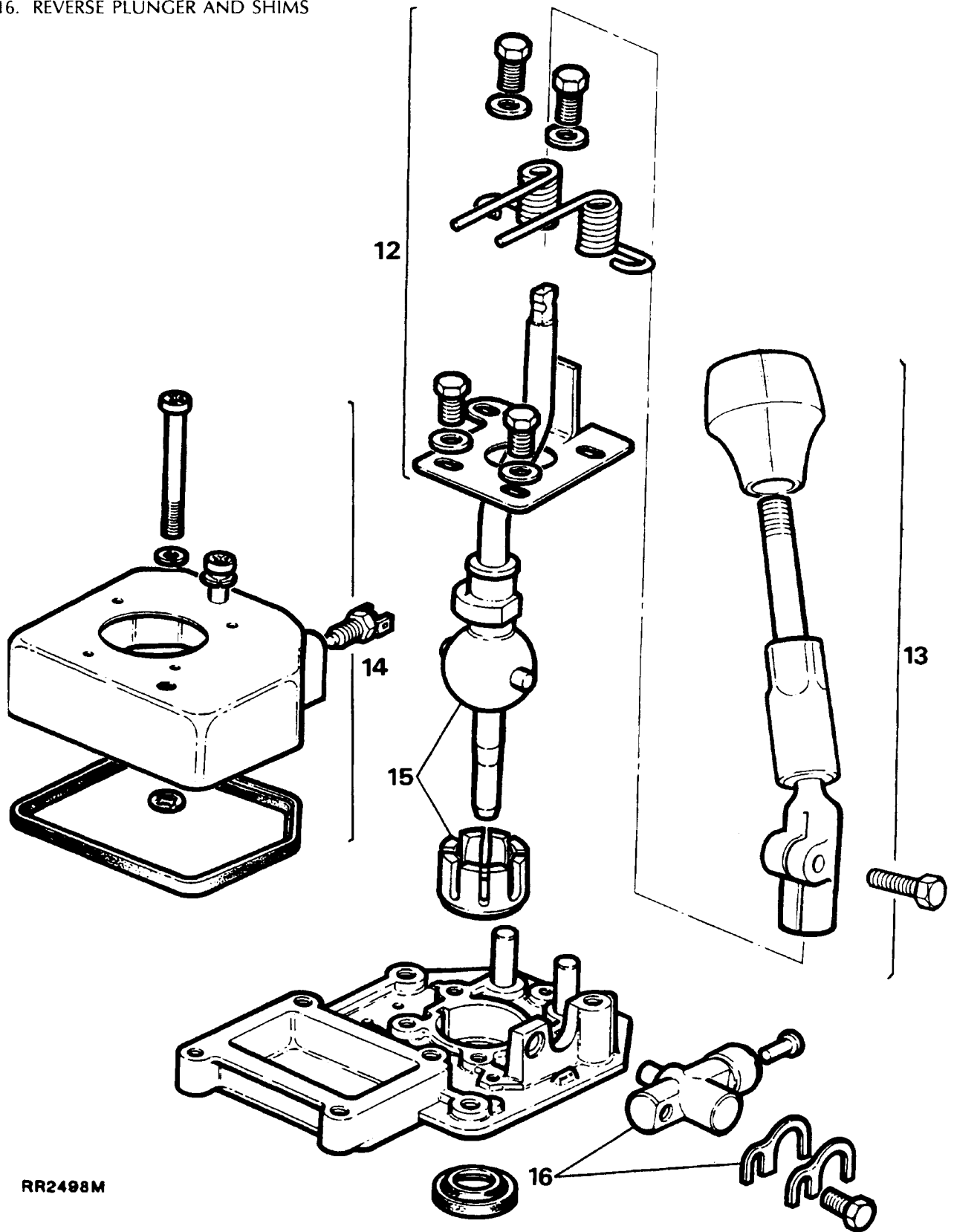

RR2498M

Third gear

2. Refit the third gear and roller bearing to the mainshaft. Check third gear end float, by placing a straight edge on the mainshaft and checking the clearance between the gear and flange on the mainshaft, between the gear face and mainshaft flange. The end float should not be in excess of 0,20 mm (0.008 in) maximum. If end float is outside specified limit check flange and gear faces for wear.

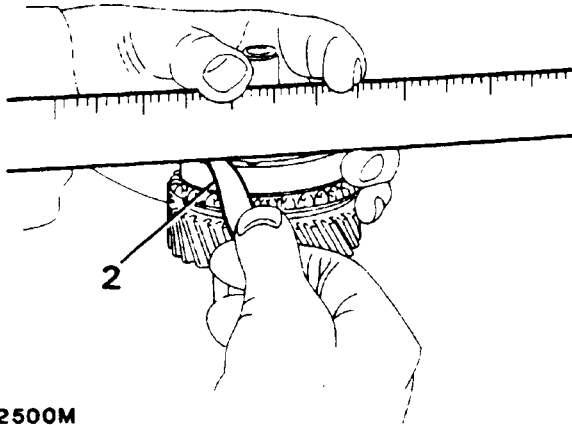

RR2500M

Second gear

3. Lubricate the second gear needle bearing with a light oil and fit the bearing and second gear to the mainshaft.
4. Check the second gear end float, by placing a straight edge on the mainshaft and checking the clearance between the gear and flange on the mainshaft, end float should not be in excess of 0,20 mm (0.008 in) maximum. If end float is outside limit inspect the flange and gear faces for wear.

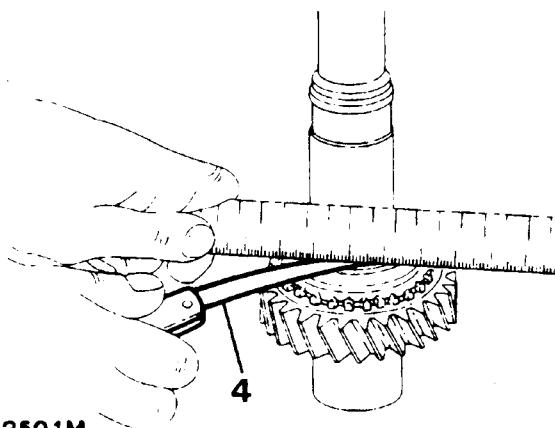

RR2501M

First gear bush end float

NOTE: It is essential to select first gear bush before checking first gear end float.

5. Fit the first and second synchromesh hub assembly with the selector fork groove to the rear of the mainshaft.

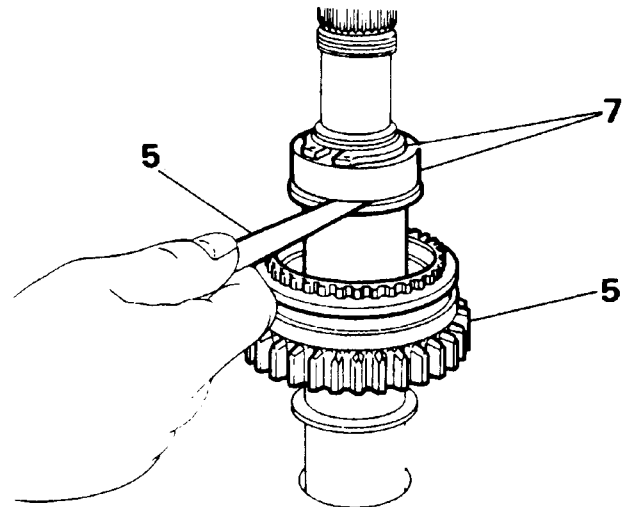

RR2502M

Continued

37 LT77 FIVE SPEED GEARBOX

6. Manufacture a spacer to the dimensions provided in the illustration at the beginning of this section, this will represent a slave bearing.
7. Fit the first gear bush and slave bearing spacer and a new circlip to the mainshaft. When fitting the circlip, care must be taken to ensure it is not opened (stretched) beyond the minimum necessary to pass over the shaft.
8. Press the slave bearing spacer back against the circlip to allow the bush maximum end float. Measure the clearance between the rear of the first gear bush and front face of the slave bearing spacer with a feeler gauge. The clearance should be within 0,075 mm (0.003 in) maximum. The first gear bush is available with flanges of different thickness. Select a bush with a flange to give the required end float. The bush must be free to rotate easily with the required end float.
9. Remove the circlip, slave bearing spacer and first gear bush from the mainshaft.
10. First gear bushes are available in the following sizes:

Part No.	Length (mm)
FRC5243	40,16 - 40,21
FRC5244	40,21 - 40,26
FRC5245	40,26 - 40,31
FRC5246	40,31 - 40,36
FRC5247	40,36 - 40,41

First gear end float

11. Fit the selected first gear bush to the first gear, place the gear and bush on a clean, flat surface so that the gear is sitting firmly on the shoulder of the bush.
12. Place a straight - edge across the bush and measure the clearance between bush and gear, this should not be in excess of 0,20 mm (0.008 in) maximum.

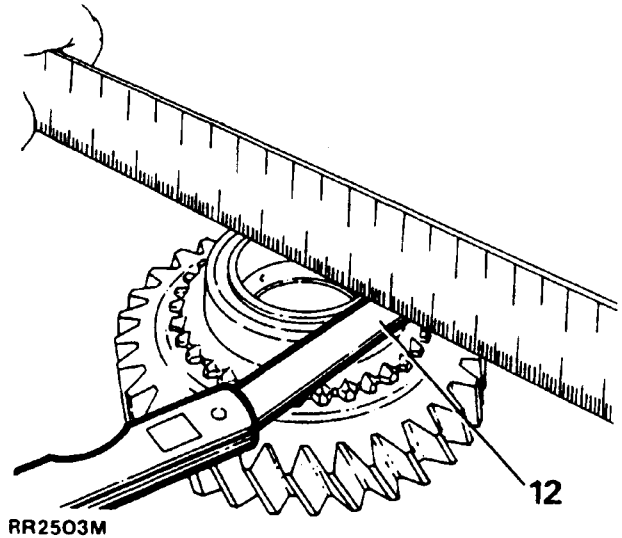

13. If the clearance is in excess of the maximum permissible limit, inspect gear faces for wear.

Layshaft

1. Examine layshaft for excessive wear, or damaged teeth. Renew as necessary.
2. Fit new bearings fully onto the layshaft using MS47 and a suitable tube.

Reverse gear and shaft

1. Remove the circlip from the reverse idler gear.
2. Remove both needle roller bearings and remaining circlip from the gear.
3. Check the condition of the reverse idler gear and its mating teeth on the layshaft and synchromesh outer unit.
4. Examine the reverse shaft for wear and renew if necessary.
5. Fit a new circlip to the rear of the reverse idler gear.
6. Lubricate with light oil and fit two new needle roller bearings. The needle roller bearings may be fitted either way round.
7. Fit a new circlip to the front of the reverse idler gear.

Selectors

1. Check the selector rail for worn or loose pins.
Note that the selector rail is only supplied complete with first and second selector fork, renew the assembly if necessary.

Selector assembly

2. Place the first/second selector fork and rail assembly on a flat surface, locate the selector pin in the jaw of the fork.
3. Fit the front spool and third/fourth selector fork, engaging the spool in the jaw of the fork.

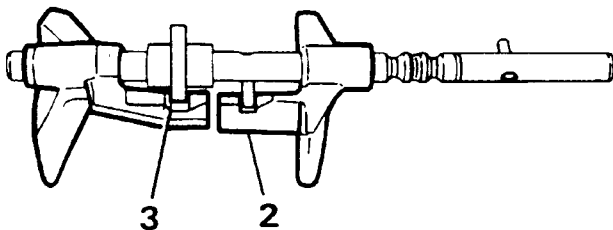

RR2504M

4. Slide the spool and fork towards the first/second selector until the slot in the spool locates over the selector pin and the spool remains engaged in the third/fourth selector fork jaw.

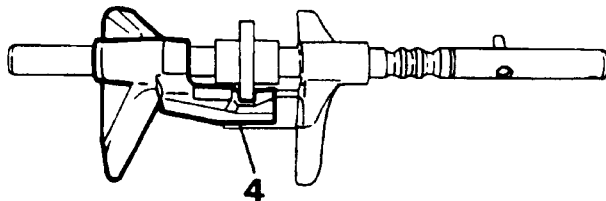

RR2505M

5. Examine the remaining selector components for wear, renew as necessary.
6. Examine the selector yoke components. If necessary remove the nylon seating by releasing the snap ring from the yoke.

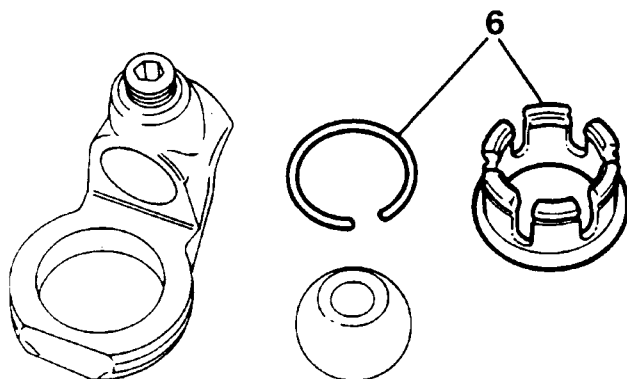

RR2506M

Continued

37 LT77 FIVE SPEED GEARBOX

ASSEMBLY

Mainshaft - rear end

NOTE: Lubricate all the needle roller bearings with a light oil before assembly.

1. Fit second gear and needle roller bearing to the mainshaft followed by the baulk ring and first/second synchromesh assembly. The synchromesh assembly may require gently tapping onto the splines using a plastic hammer.

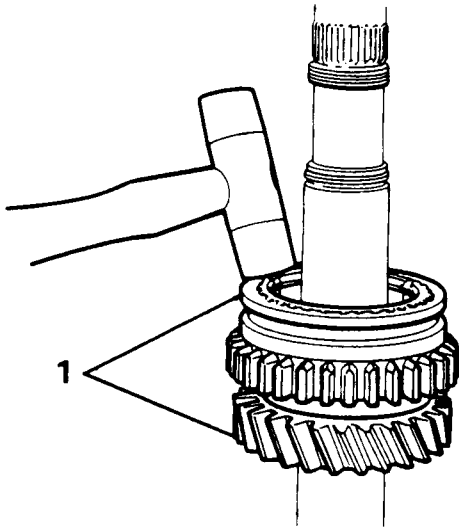

RR2507M

2. Fit the first gear baulk ring, first gear, needle roller bearing and selected bush to the mainshaft.
3. Using tools MS47, 18G47BA and 18G47BA - X refit the centre bearing to the mainshaft. Note that the larger spigot diameter of 18G47BA - X locates in the bearing cage. Ensure that the slots in the baulk ring align with the slipper blocks when pressing bearing.

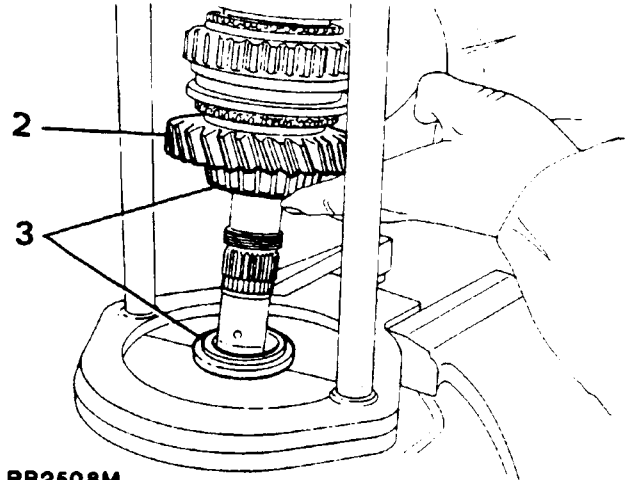

RR2508M

4. Fit the circlip, ensuring that the bearing, gear and circlip are in their rearmost position on the mainshaft. This is achieved by placing two bars under the 1st gear and carefully pressing the assembly rearwards on the mainshaft using press MS47. Check that there is no clearance between circlip and bearing, and that the bush is free to turn.

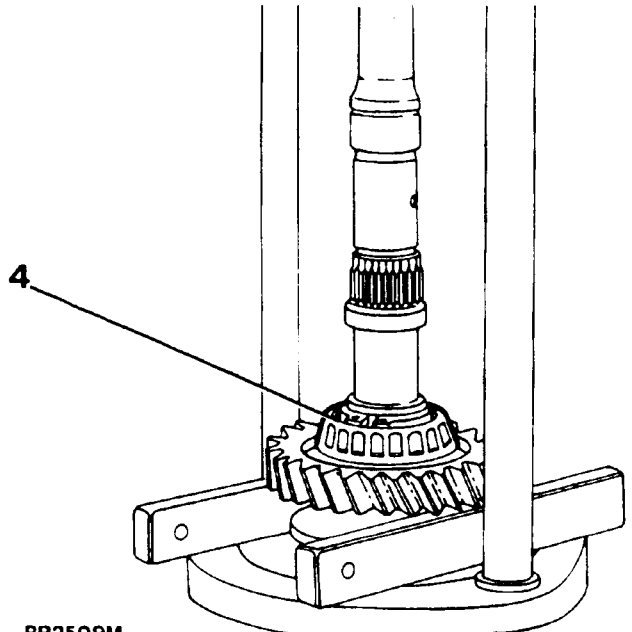

RR2509M

Mainshaft - front end

5. Invert the mainshaft, lubricate the third gear needle roller bearing with light oil, fit to the front end of the mainshaft.
6. Fit the third gear to the mainshaft; and locate the third gear baulk ring to the third gear.
7. Fit the third/fourth synchromesh assembly (with the raised centre boss of the synchromesh hub to the front of the gearbox) to the mainshaft.
8. Fit the spacer and press the pilot bearing to the front of the mainshaft.

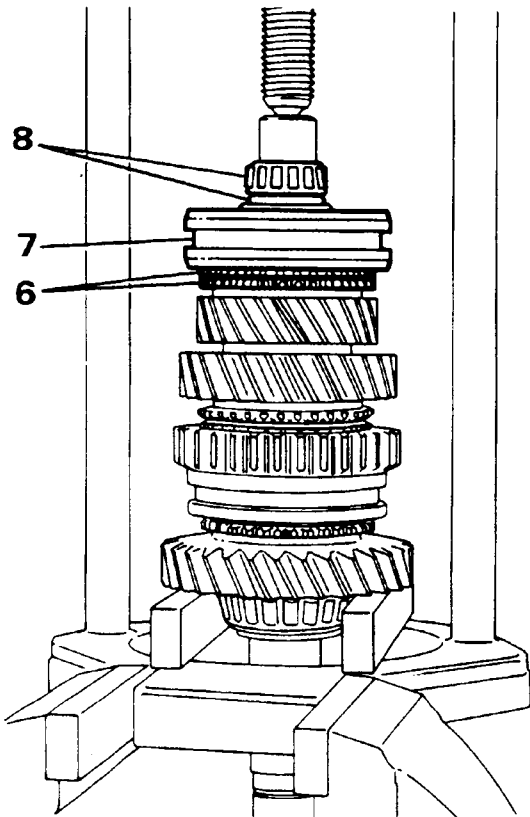

RR2510M

WARNING: The mainshaft assembly **MUST** be supported on 1st gear when fitting the pilot bearing.

Centre plate

1. Fit the centre plate to the workstand and secure with a nut and bolt.
2. Place the new mainshaft and layshaft bearing tracks in the centre plate.
3. Ensure both synchromesh units are in neutral. Fit the selector shaft assembly complete, engaging both selector forks in their respective synchromesh sleeves on the mainshaft.
4. Lubricate the selector shaft with a light oil. Engage the selector shaft and mainshaft assemblies in the centre plate, whilst rotating the fifth gear selector pin to align with the slot in the centre plate.
5. Fit the layshaft assembly to the centre plate, lifting the mainshaft assembly slightly to clear the rear layshaft bearing.

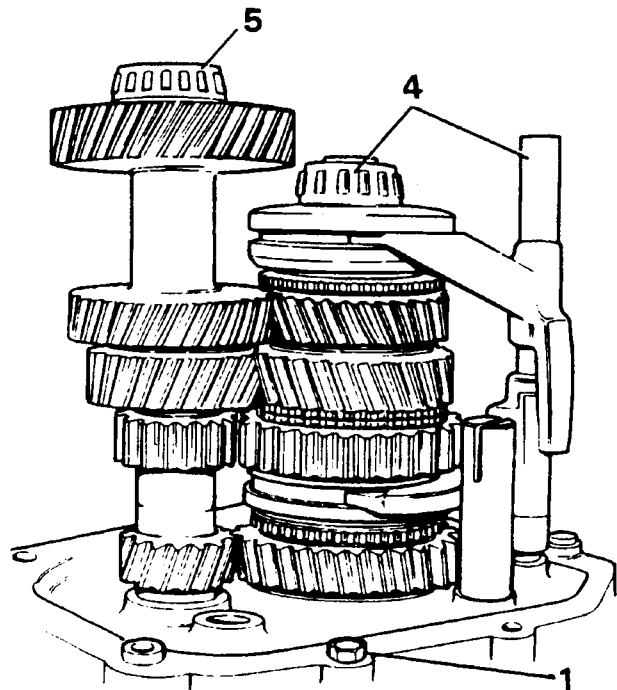

RR2511M

6. Rotate the selector shaft and spool to enable the reverse crossover lever forks to correctly align to the selector pin. Reposition the selector shaft and locate the lever into the slot of the reverse gear pivot shaft.
7. Insert pivot pin and fit a new circlip (earlier models only), ensuring that it is not opened beyond the minimum necessary to pass over the shaft.

Continued

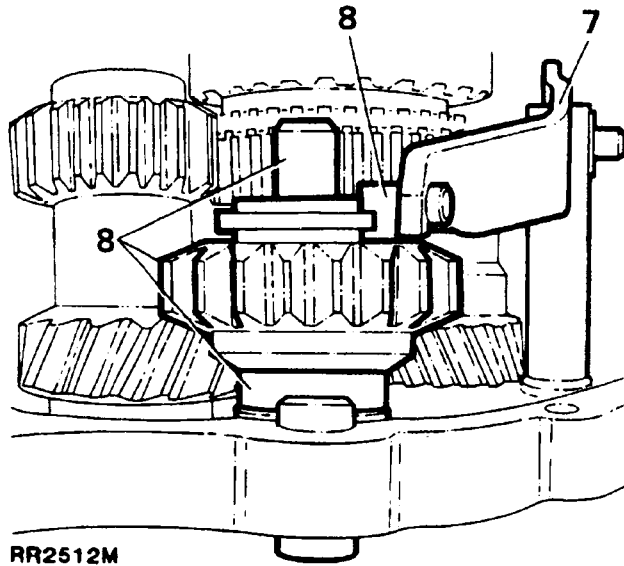

RR2512M

8. Fit the slipper pad to the reverse lever. Fit the reverse gear spacer and reverse gear assembly, locating the slipper pad lip to the reverse gear groove. Engage the reverse gear shaft from the underside of the centre plate, ensuring the roll pin is aligned with the slot in the centre plate casing. Secure the reverse shaft using the retaining plate.
9. Check that a running clearance exists between the slipper pad and lever, with a maximum clearance of 0,725mm (0,025in).
10. Fit the reverse gear thrust washer to the reverse gear shaft.
11. Locate the fourth gear baulk ring to the third/fourth synchromesh assembly.
12. Fit the input shaft to the mainshaft.
13. Release the bolt securing the centre plate to the workstand and fit a new gasket to the centre plate.

Main gearbox casing

14. Ensure that the selector rail and spool are in the neutral position.
15. Lubricate the detent ball and spring with light oil, and fit to the top of centre plate. Fit and tighten the plug fully to ensure the selector rail does not move when the gearcase is fitted.

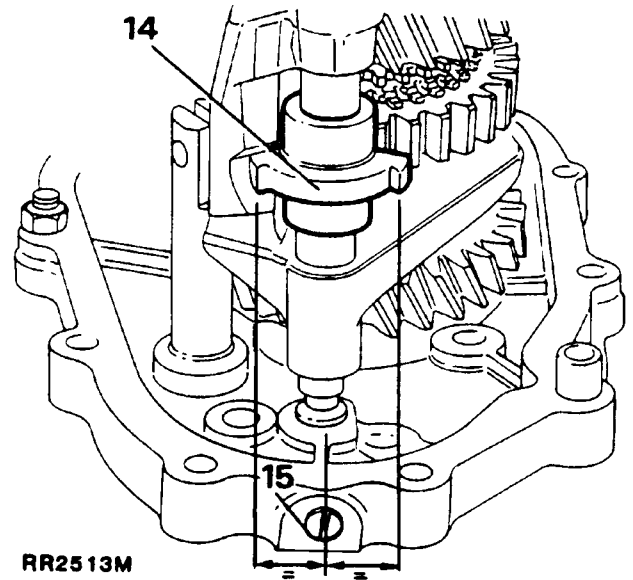

RR2513M

16. Fit the two guide studs into the casing, one each side.
17. Carefully lower the gearcase into position over the gear assemblies. **DO NOT USE FORCE.** Ensure the centre plate dowels and selector shaft are engaged in their respective locations.
18. Resecure the assembly to the workstand. Using two 8 X 35 mm slave bolts, with plain washers to prevent damage to the rear face of the centre plate, temporarily secure the gear case to the centre plate.
19. Fit the front spool retainer (with new 'O' ring if fitted) to the top of the gearcase using Hylomar PL32 on the joint face, if 'O' ring is not fitted. Smear Hylomar PL32 on the bolt threads, fit bolts and spring washers. Finally tighten to the correct torque.

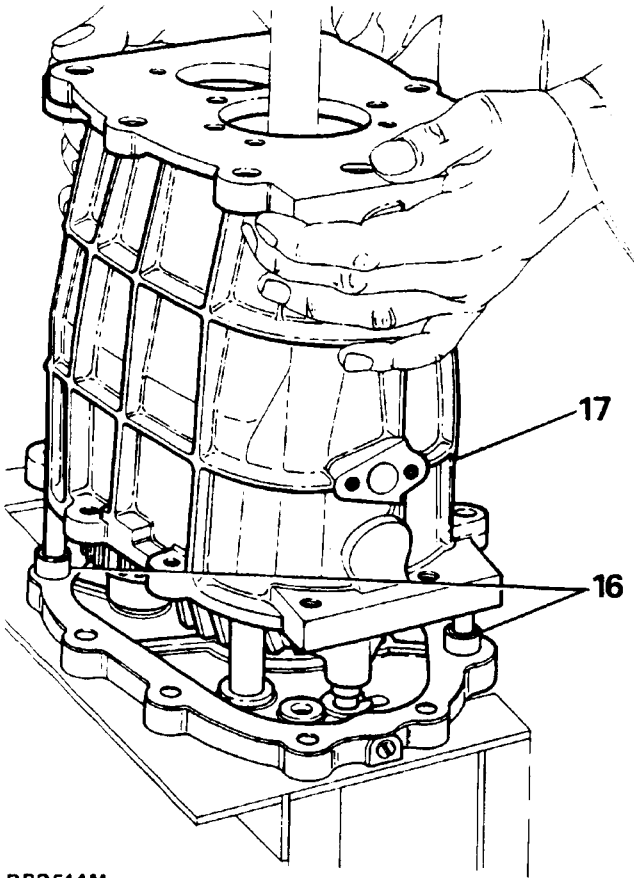

RR2514M

NOTE: Do not use force when fitting spool retainer. Provided the spool has not been disturbed the retainer will slide into position. If the selector rail is rotated or disturbed during assembly remove the main gearbox casing and dismantle the centre plate to rectify.

20. Remove the detent retaining plug, smear the threads with Loctite 290 or Hylomar PL32, and screw in until flush with case. Stake the plug to prevent rotation using a suitable centre punch.
21. Fit the layshaft and input shaft bearing outer tracks.
22. Fit the layshaft support plate using two 8 X 25 mm bolts and washers to the front of the gearbox, with the plain washer situated between the support plate and layshaft. The plate also retains the input shaft bearing outer track.
23. Remove the assembly from the workstand and invert, resecuring to the workstand. Remove the reverse retainer plate.

Fifth gear

1. Press or drive the fifth gear onto the layshaft, using 18G1422, ensuring that the annular extraction groove is to the rear.
2. Fit a new 22 mm stake nut and tighten sufficiently to retain.
3. Fit the fifth speed thrust washer, roller bearing, fifth gear and baulk ring to the mainshaft.
4. Press fifth gear synchromesh hub assembly fully onto the shaft using tool 18G1431, ensuring that the slipper pads locate in the three slots in the baulk ring.

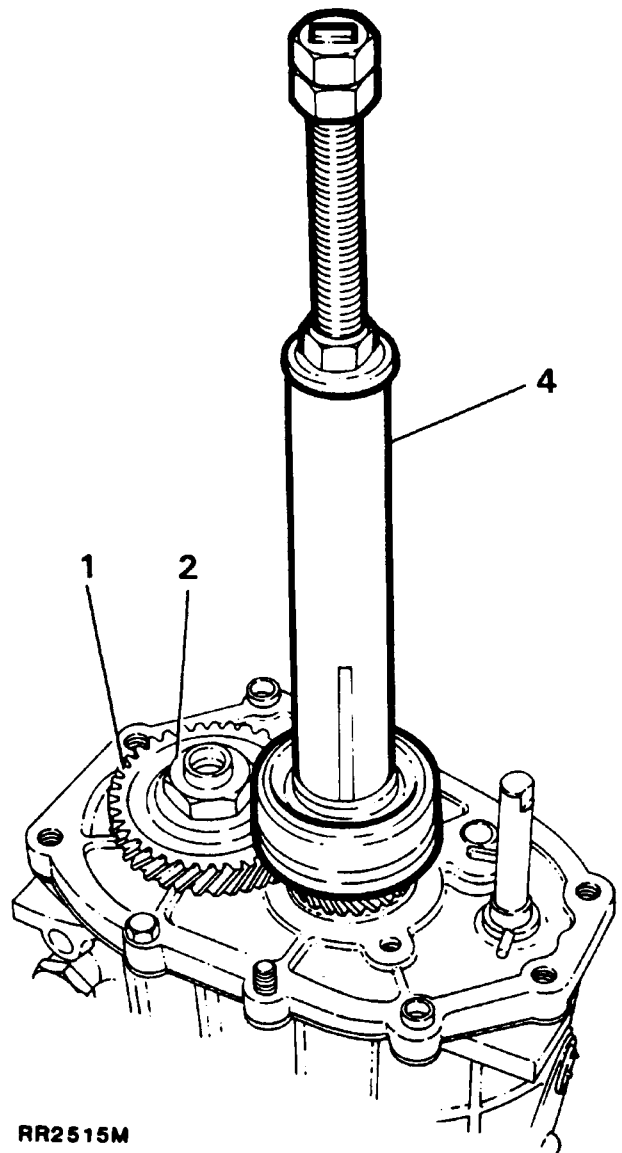

RR2515M

37 LT77 FIVE SPEED GEARBOX

- Fit a dummy selective washer which has an oversize bore for ease of fitting. It is recommended that the thinnest washer (FRC 5284) is used. Locate the circlip in its groove. Measure the clearance between the washer and circlip, which should be 0,005 to 0,055 mm,(0.0002 - 0.002in) maximum. The washers are available in ten sizes to obtain the correct clearance.

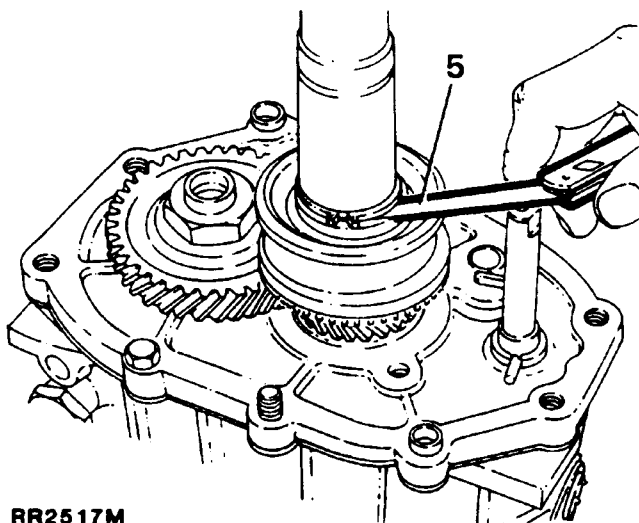

RR2517M

Part No.	Thickness (mm)	Part No.	Thickness (mm)
FRC5284	5,10	FRC5294	5,40
FRC5286	5,16	FRC5296	5,46
FRC5288	5,22	FRC5298	5,52
FRC5290	5,28	FRC5300	5,58
FRC5292	5,34	FRC5302	5,64

- Fit the correct selective washer and new circlip.
- Secure the flange holder 18G1205 to the gearcase.
- Fit fifth gear retainer to case and fifth layshaft gear.
- Tighten the staked nut securing layshaft fifth gear to the correct torque. Stake the nut using a suitable punch to secure. Remove flange holder and gear retainer.

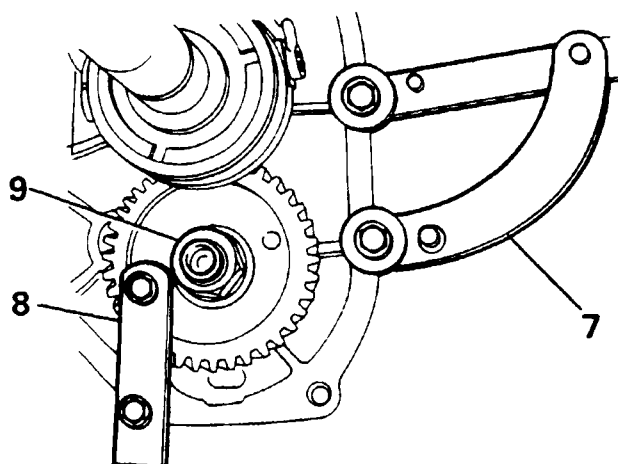

RR2516M

Fifth gear selector fork assembly

- Fit the fifth gear selector fork bracket to the centre plate with the bolts and spring washers and tighten to the correct torque.
- Fit fifth gear spool to the selector shaft, the longer shoulder of the spool fitted towards the front of the gearbox.

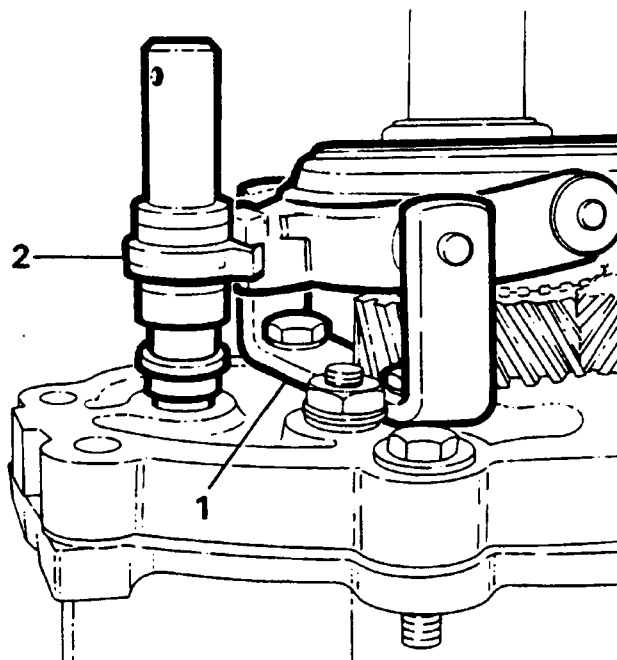

RR2518M

- Fit the bronze pads to the 5th gear selector fork (retain with vaseline), engage the fork, ensuring that the larger side of the selector jaw faces to the rear, with the spool, bracket and synchromesh sleeve. Insert the two dowel pins and secure in position with the two 'E' clips.

Extension case

1. Remove the two bolts securing the centre plate and fit a new gasket to the joint face.
2. Fit the oil pump drive shaft to layshaft and align the pump gears.
3. Secure the selector yoke to the selector shaft with a NEW 10 mm grub screw tightened to the correct torque.

NOTE: The NEW grub screw is encapsulated with loctite during manufacture.

4. Carefully lower the extension casing into position. DO NOT use force, if difficulty is encountered, remove the case and align oil pump gears and drive shaft.
5. Remove the guide studs and fit the extension case bolts and spring washers, tighten to correct torque.
6. Cover the mainshaft splines with masking tape and fit a new oil seal collar 'O' ring. Remove the masking tape.

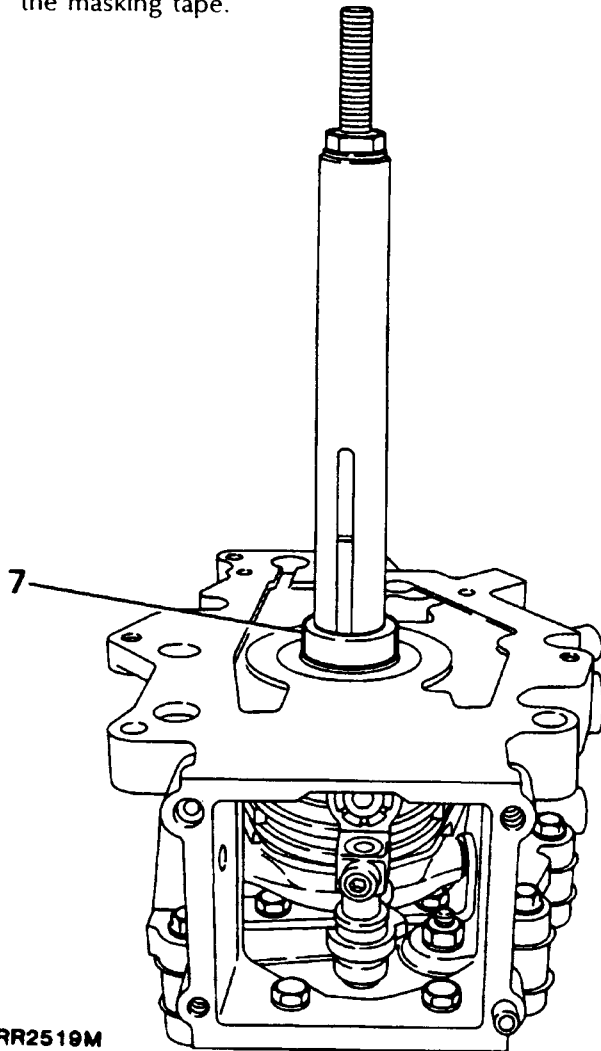

RR2519M

7. Using tool 18G1431 fit a NEW oil seal collar to the mainshaft, ensuring the collar is pushed on the shaft with sufficient clearance to allow the circlip to engage in its groove. The groove may be observed through the slot in the tool.

Input/mainshaft bearing adjustment

1. Invert the assembly on the workstand, and remove the layshaft retaining plate.
2. Fit the original selective washer to the input shaft bearing and fit the front cover without the gasket. Do not fit the layshaft washer at this stage.
3. Retain the cover with four bolts, with plain washers only, around the input shaft. Secure evenly, finger tight.

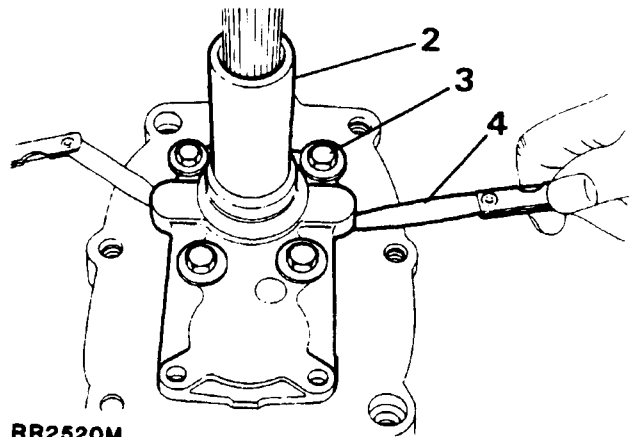

RR2520M

4. Check the clearance between the cover and the gearcase using two feeler gauges as shown. If necessary change the selective washer to obtain a clearance of 0,20 to 0,26 mm (0.008 to 0.010 in). This will ensure the end float is within tolerance when the gasket is fitted and the cover tightened to the correct torque.

Continued

Input/main shaft selective washers

Part No.	Thickness (mm)	Part No.	Thickness (mm)
FRC4327	1,51	FRC4349	2,17
FRC4329	1,57	FRC4351	2,23
FRC4331	1,63	FRC4353	2,29
FRC4333	1,69	FRC4355	2,35
FRC4335	1,75	FRC4357	2,41
FRC4337	1,81	FRC4359	2,47
FRC4339	1,87	FRC4361	2,53
FRC4341	1,93	FRC4363	2,59
FRC4343	1,99	FRC4365	2,65
FRC4345	2,05	FRC4367	2,71
FRC4347	2,11	FRC4369	2,77

- Remove the cover and retain selective washer for final assembly.

Layshaft bearing adjustment

- The correct adjustment for the layshaft bearing is 0,025mm (0,001m) end float, and zero to 0,025 mm (0,001 in) preload. The following operation will ensure a preload figure within these tolerances. The input bearing selective washer must not be fitted during this operation.
- Measure the thickness of a new cover gasket and the original selective washer.
- Fit the original layshaft selective washer, and secure the cover (without gasket) with four bolts and plain washers, finger tight, around the layshaft.

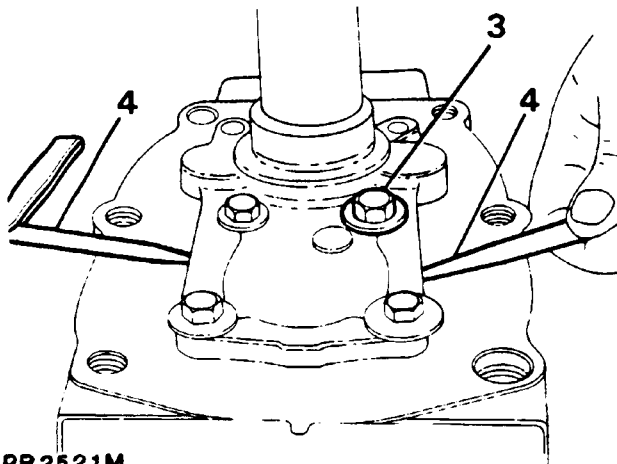

- Check the clearance using two sets of feeler gauges and select a washer to give a clearance equal to the thickness of the new gasket.

Layshaft selective washers:

Part No.	Thickness (mm)	Part No.	Thickness (mm)
TKC4633	1,69	TKC4649	2,17
TKC4635	1,75	TKC4651	2,23
TKC4637	1,81	TKC4653	2,29
TKC4639	1,87	TKC4655	2,35
TKC4641	1,93	TKC4657	2,41
TKC4643	1,99	TKC4659	2,47
TKC4645	2,05	TKC4661	2,53
TKC4647	2,11	TKC4663	2,59

Layshaft selective washers - increased capacity bearings:

Part No.	Thickness (mm)	Part No.	Thickness (mm)
FTC0262	1,36	FTC0280	1,90
FTC0264	1,42	FTC0282	1,96
FTC0266	1,48	FTC0284	2,02
FTC0268	1,54	FTC0286	2,08
FTC0270	1,60	FTC0288	2,14
FTC0272	1,66	FTC0290	2,20
FTC0274	1,72	FTC0292	2,26
FTC0276	1,78	FTC0294	2,32
FTC0278	1,84	FTC0296	2,38

- Remove the front cover. Having ascertained the mainshaft and layshaft end float, fit the appropriate mainshaft and layshaft selective washers to the mainshaft and layshaft bearing tracks.
- Fit a new oil seal to the front cover, ensuring the seal lips face towards the gearbox. Lubricate the seal lips with SAE 140 gear oil.
- Mask the splines with masking tape to protect the oil seal, refit the front cover and remove the spline masking tape.
- Refit the bolts and spring washers having applied Hylomar PL32 to the bolt threads. Tighten to the specified torque.

Bell housing

1. Refit the dowels, and locate the bell housing on the dowels and fit the two long bolts (12 X 45 mm) with spring and plain washers to the dowel positions. The remaining four bolts (12 X 30 mm) are fitted with spring washers only. Tighten to the correct torque.
2. Slide the release bearing guide over the input shaft, and secure in position with the single bolt and clutch release pivot post, tighten to the correct torque.

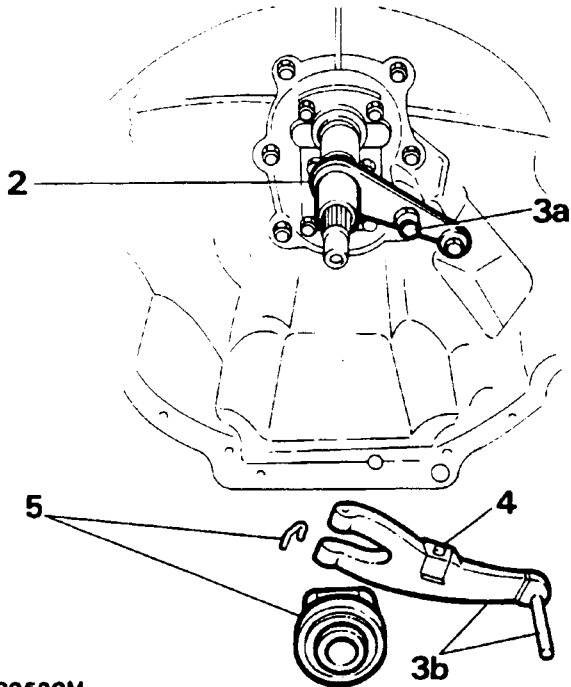

RR2522M

3. Prior to assembly, lubricate the following items with a thin film of molybdenum disulphide grease.
 - (a) Clutch release pivot post and locating socket in release lever.
 - (b) Ball end of the clutch operating push rod.

NOTE: Do not lubricate the bearing guide.

4. Locate the clutch release bearing lever on the pivot ball and secure in position with the spring clip, tighten the clip securing bolt to the correct torque.

5. Slide the clutch release bearing over the bearing guide. Fit a new plastic staple to clutch release lever and bearing to prevent the bearing sliding off the guide.

Gear change housing

1. Remove the gearbox from the stand and place on the bench.
2. Refit the gearchange housing to the extension housing using a new gasket. Ensure that the gear lever engages with the selector yoke, and the spool and guide engage correctly.
3. Fit and tighten the securing bolts.

Bias adjustment plate setting

4. Ensure that the bias plate is free to slide. Select fourth gear and load the gear lever fully to the right hand side of the gearbox.
5. Tighten the four adjustment plate bolts to the correct torque.
6. Check the adjustment by testing third and fourth gear selection. After adjustment the lever should lie centrally in the third and fourth plane, with no dog leg into gears. Equal side movement should exist in third and fourth gears.

Continued

Reverse plunger assembly setting

7. Fit the assembly to the housing and secure in position with the single bolt and washer.
8. Select first gear. Using feeler gauges, check the gap between the reverse plunger nose and the side of the gear lever.

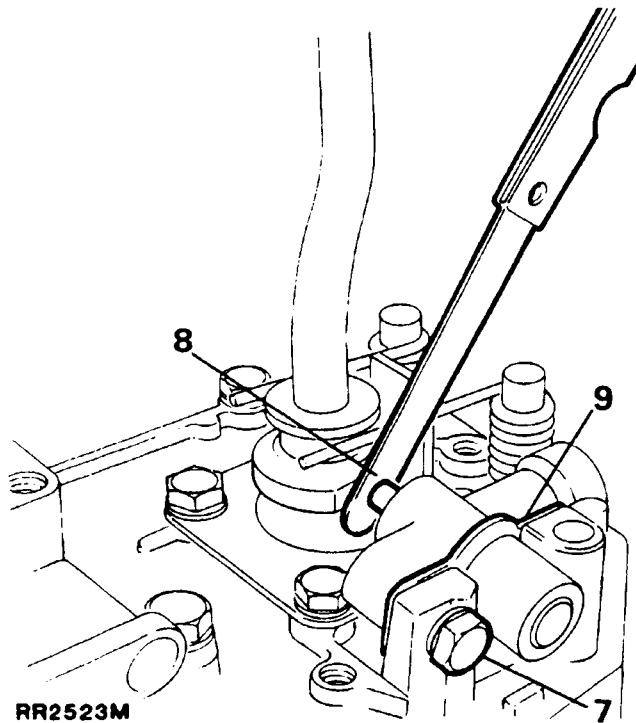

9. The required setting is 0,6 to 0,85 mm (0.024 to 0.034 in) clearance. Adjust the gap by adding or removing the shims behind the plunger assembly.
10. Ensure that the reverse light operating plunger is fitted to the reverse plunger. Fit the top cover and sealing rubber and tighten the securing screws. Refit and adjust reverse light switch.
11. Fit a new fibre washer to the oil drain plug, fit the plug to the gearbox and tighten to the correct torque.
12. Refill the gearbox with the correct quantity and grade of oil as specified in the 'Recommended Lubricants' section.
14. Refit the gearbox oil level plug, and tighten to the correct torque.
15. Refit the transfer gearbox and fit the assembly to the vehicle.

ZF MAIN GEARBOX AND BORG WARNER TRANSFER GEARBOX - ADAPTOR PLATE

To assist in the removal of the transmission assembly from the vehicle it is necessary to locally manufacture an adaptor plate to use in conjunction with a transmission hoist.

NOTE: Four holes (A) to be countersunk on underside to suit hoist.

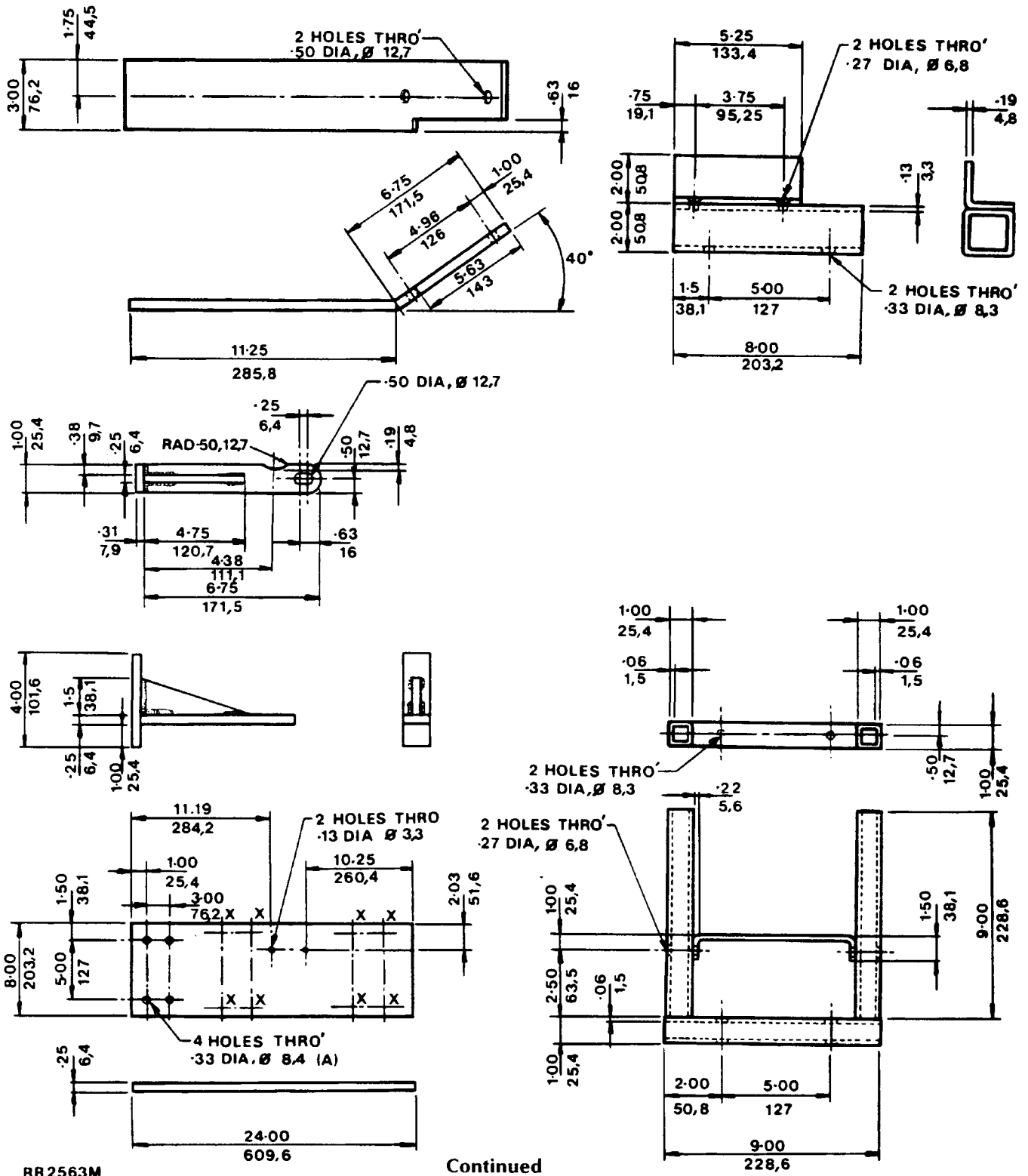

RR2563M

Continued

44 AUTOMATIC GEARBOX

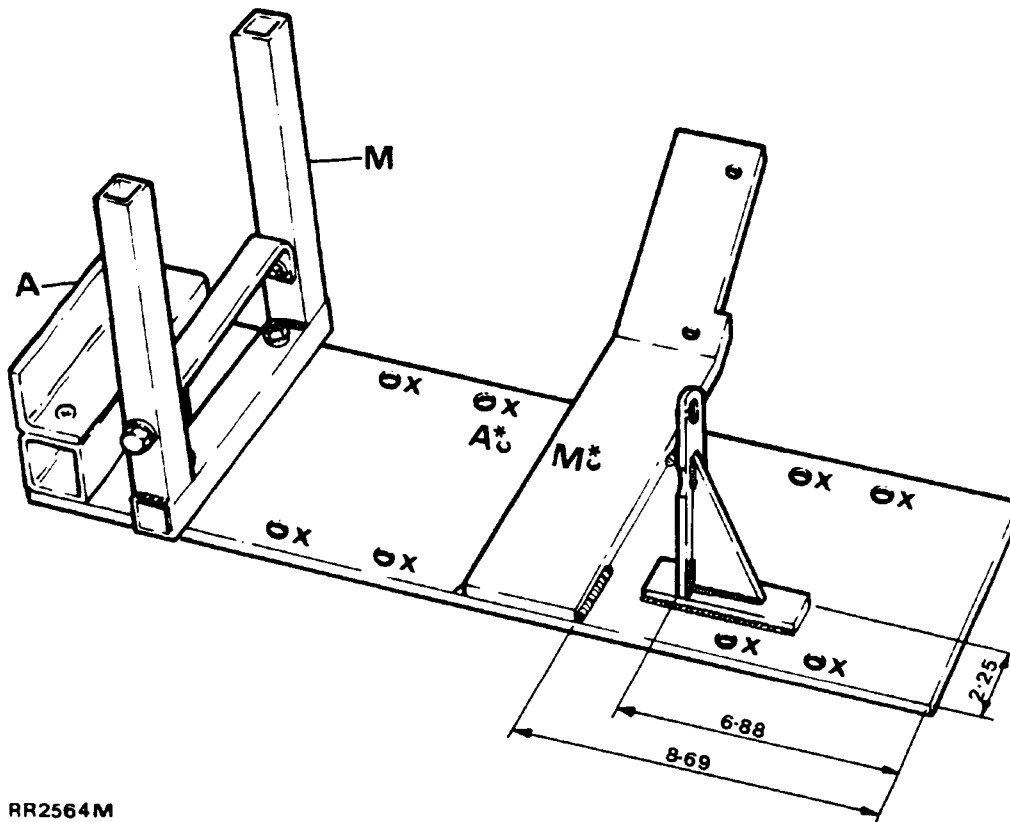

- A: Automatic gearbox models
- M: Manual gearbox models
- A*: Centre of the lifting hoist (Automatic models)
- M*: Centre of the lifting hoist (Manual models)
- X: Drill fixing holes to suit hoist table

Material: Steel plate BS 1449 Grade 4 or 14

**ZF MAIN GEARBOX AND BORG WARNER
TRANSFER GEARBOX**

Remove and refit

Preparation - under bonnet

WARNING: Where the use of a transmission hoist is necessary, it is **ABSOLUTELY ESSENTIAL** to follow the hoist manufacturer's instructions to ensure safe and effective use of the equipment.

1. Install the vehicle on a hydraulic ramp and chock the road wheels.
2. Disconnect the battery negative terminal.
3. Release and remove the fan blade assembly. Note the assembly has a left hand thread.
4. **Fuel injection models** - Release the clamp and remove the air intake hose from the neck of the plenum chamber.
Carburettor models - Remove the air cleaner and elbows.
5. Disconnect the kickdown cable from the throttle linkage.
6. Release the two gearbox breather pipes from the clip located on the lifting eye at the rear of the right hand cylinder head.
7. Remove the gearbox dipstick.

Inside the vehicle

8. Select low range, unscrew and remove the transfer gearbox knob.
9. Unclip the top cover of the main gearbox selector and remove the circlip, withdraw the detent button. Remove the circlip above the selector knob retention nut, remove the nut, serrated washer and withdraw the selector knob.
10. Carefully prise the inset panel out of the floor mounted console, complete with gear selector illumination panel and ashtray. Disconnect the electrical multi - plug to the graphics panel, and remove the inset panel.
11. Release the four screws and remove the glove box liner.
12. Carefully prise the window lift switch panel from the front of the glove box. Push the panel complete with switches back through the panel opening and place on the gearbox tunnel.

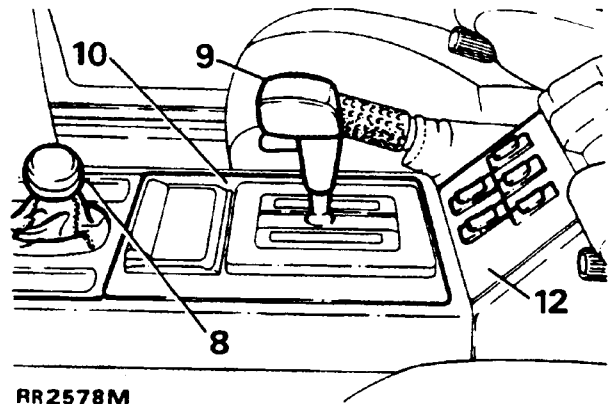

13. Release the two bolts and two screws securing the glove box/console assembly to the gearbox tunnel.

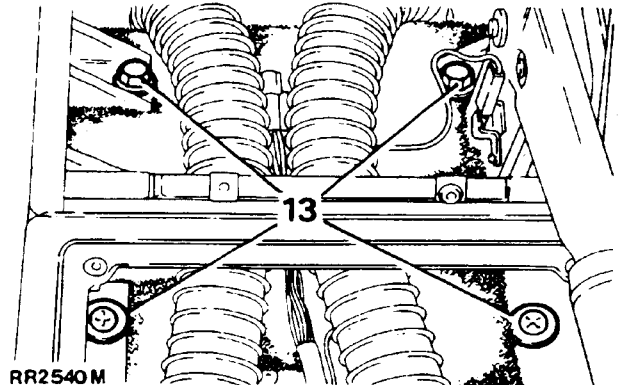

14. Detach the two relays from the inner side of the glove box.
15. Disconnect the electrical leads to the rear cigar lighter.
16. Disconnect the handbrake cable from the handbrake lever. Raise the lever while simultaneously detaching the glove box/console assembly from the lower dash. Remove the assembly from the vehicle.
17. Remove the retaining clip and pull the handbrake adjustment thumb wheel from the outer sleeve. Push the inner sleeve to the underside of the vehicle.
18. Remove the sound deadening trim from the top of the gearbox tunnel.
19. Remove the screws and detach the retaining plate from around the transfer gearbox lever.

Continued

44 AUTOMATIC GEARBOX

Under the vehicle

20. Raise the hydraulic ramp.
21. Remove the main and transfer gearbox oil drain plugs. Where applicable remove the filler plug to assist draining and drain the oil into suitable containers. While the oil is draining continue with the following operations.

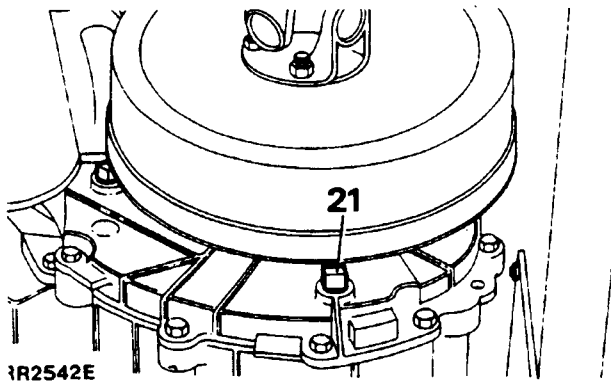
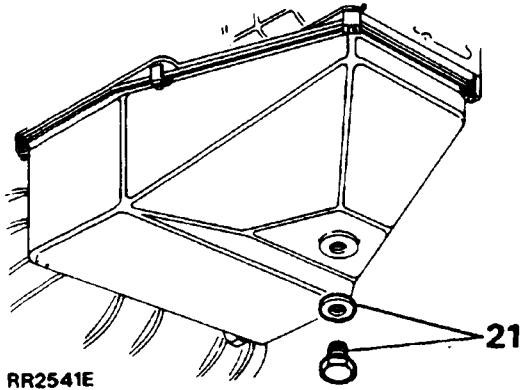

22. **Catalyst models only** - Disconnect the multi-plugs to the Lambda sensors.
23. Remove the eight fixings securing the cross member. Note it may be necessary to spread the chassis to enable the cross member to be withdrawn.

NOTE: The above operation will require the assistance of a second operator to support the exhaust system while the various fixings are released.

24. Remove the front exhaust down pipes and intermediate pipe complete with centre silencer (or catalyst).

25. Release the two clamps at the side of the engine sump that secure the two gearbox oil cooler feed and return pipes.
26. Place a suitable container below the gearbox, disconnect the oil cooler feed and return pipes from the bottom and side of the gearbox. Plug the pipes and openings to prevent ingress of foreign matter.
27. Disconnect the dipstick tube from the front of the gearbox oil pan.
28. Mark each propeller shaft drive flange at the transfer gearbox with an identification line to aid re-assembly, remove the fixings and disconnect the propeller shafts at the output flanges. Tie the shafts to one side.
29. Release the nut and disconnect the speedometer cable from the rear output housing, tie the cable to one side.
30. Disconnect the main gearbox selector cable and rod from the left side of the gearbox. Lay the cable aside.
31. Disconnect the main gearbox inhibitor switch multi-plug from the main harness.
32. If fitted disconnect the speed transducer multi-plug from the main harness.

Remove the transmission assembly

33. Remove the nine front cover plate bolts from the bottom of the gearbox bellhousing, detach the cover plate to gain access to the four torque converter fixing bolts.

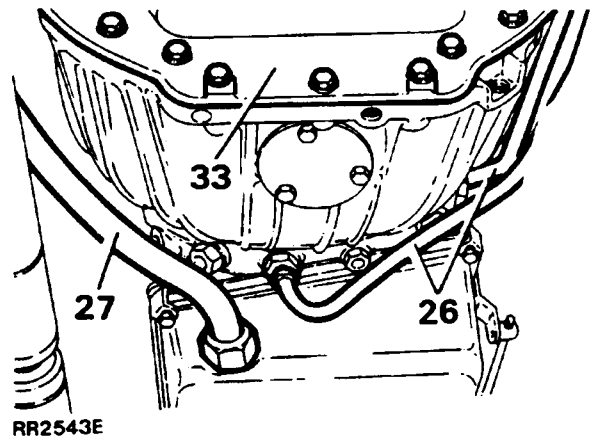

34. Rotate the engine using the crankshaft pulley until two of the access holes in the drive plate/ring gear assembly are visible through the bell housing bottom cover opening.
35. Remove the two bolts that are visible through the access holes, which secure the drive plate to the torque converter. Mark one of the access holes and a bolt hole in the converter with an identification line to aid re-assembly and to maintain original build setting.
36. Rotate the crankshaft 180° until the remaining access holes are visible, remove the remaining two bolts.

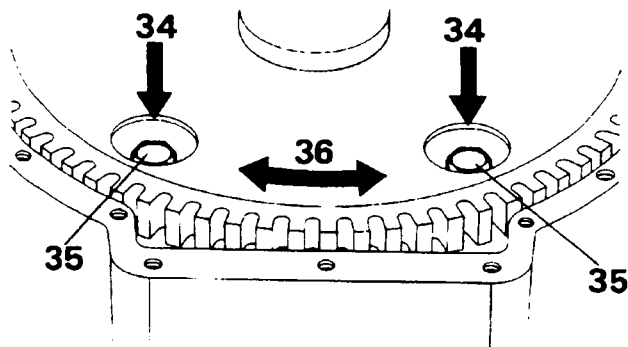

RR2544E

44. Remove the bellhousing bolts noting that one of the bolts also secures the gearbox dipstick tube.
45. Withdraw the transmission assembly from the engine, ensuring that the torque converter is removed with the gearbox and does not stay on engine.

Refitting

46. Refitting the gearbox is a reversal of the removal procedure noting the following points.
47. The flexible drive plate to torque converter bolts are to be coated with Loctite 270 prior to assembly.
48. Tighten all fixings to the specified torque. Refer to torque charts in main Workshop Manual.
49. New gaskets are to be fitted to the exhaust flanges, all joints other than those fitted with doughnuts, to be coated with 'Firegum Putty'. Check the system, if any leaks are evident reseal as necessary.

37. Position a suitable transmission floor jack on the rear output housing or brake drum to support the weight of the transmission assembly.
38. Remove the fixings and withdraw the transfer gearbox mountings.
39. Fit the previously manufactured fixture on a transmission hoist, raise the hoist and position the fixture and hoist under the transfer gearbox mounting points.
40. Using the original gearbox mounting bolts secure the fixture to the gearbox.
41. Remove the transmission floor jack from the rear of the transfer gearbox.
42. Carefully lower the transmission until the top of the transfer gearbox clears the rear passenger footwell.
43. Position the transmission floor jack under the engine to support the weight while the bellhousing bolts are removed.

HANDBRAKE CABLE

Remove and refit

Removing

Inside the vehicle

1. Set the vehicle on level ground or install on a hoist, select 'P' in automatic gearbox and neutral in manual gearbox. Disconnect the battery negative terminal.
2. Chock the road wheels.
3. Fully release the handbrake lever.
4. Remove the four retaining screws and lift out the glove box liner to gain access to the bottom of the handbrake lever.
5. Remove the split pin and withdraw the clevis pin and washer securing the cable to the handbrake lever.
6. Remove the clip from above the adjustment thumbwheel, push the inner and outer cable to the underside of the vehicle.
7. Pull the thumbwheel from the outer sleeve.

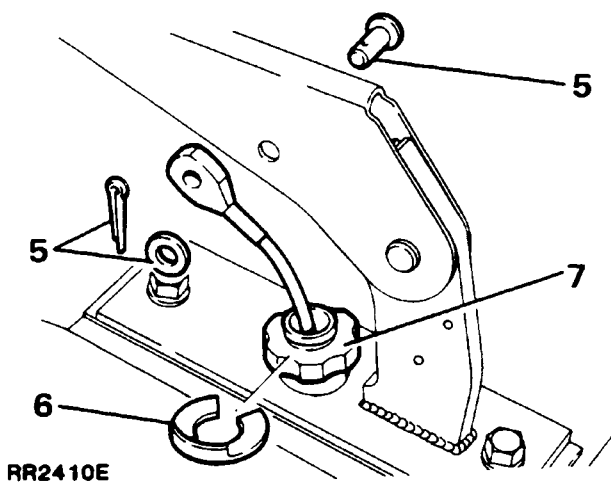

Underneath the vehicle

8. Remove the split pin and withdraw the clevis pin and washer.
9. Detach the retaining clip securing the outer cable to the support bracket located on the front cover of the transfer gearbox.
10. Release the cable from the 'P' clip located on the left hand side of the transfer gearbox.

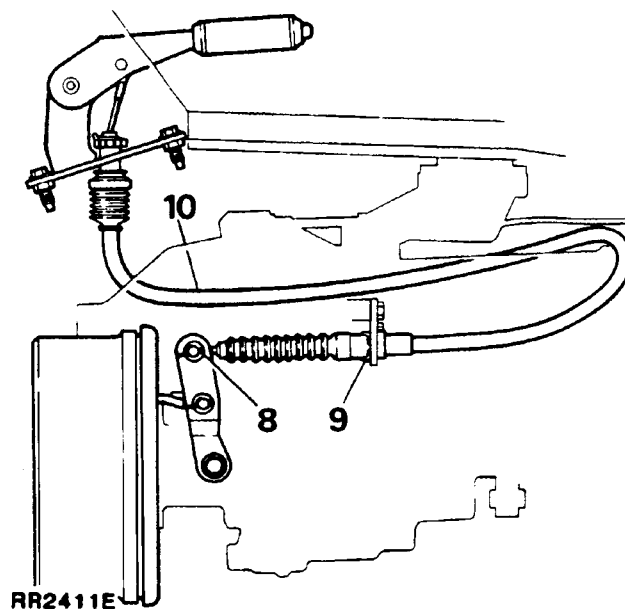

11. Withdraw the cable.

Fit new cable

12. Reverse instructions 5 to 11 when fitting a new cable.

Adjust handbrake

13. Ensure that the handbrake lever is fully released.
14. From underneath the vehicle, rotate the adjuster on the brake drum back plate clockwise until the brake shoes are fully expanded against the brake drum.

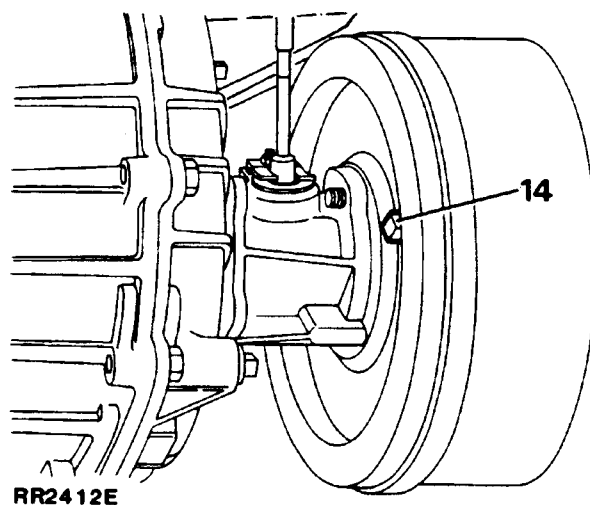

Continued

70 BRAKES

15. Back off the adjuster until the drum is free to rotate.
16. Rotate the adjustment thumbwheel below the handbrake lever until the parking brake is fully operational on the third notch of the ratchet.

NOTE: The handbrake adjustment thumbwheel must only be used for initial setting and to compensate for cable stretch, it must not be used to take up brake shoe wear, which must continue to be adjusted at the brake drum.

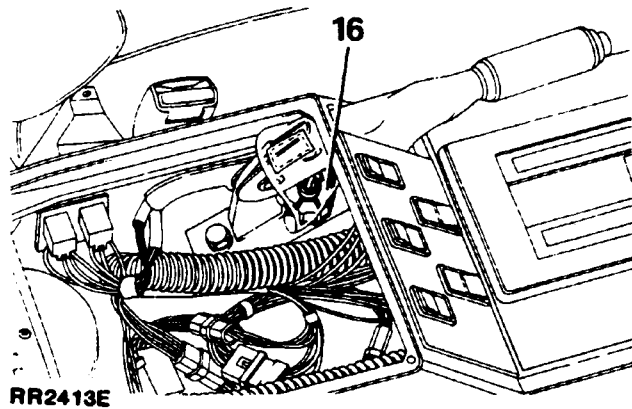

17. Operate the handbrake once or twice to settle the brake shoes, recheck that the handbrake is fully operational on the third notch of the ratchet. Re - adjust as necessary.
18. Refit the glove box liner.
19. Reconnect the battery and remove the wheel chocks.

FRONT DOOR - TRIM PANEL - 4 Door models

Remove and refit

Removing

1. Disconnect the battery negative terminal.
2. Remove the screw securing the handle bezel.
3. Remove the bezel.

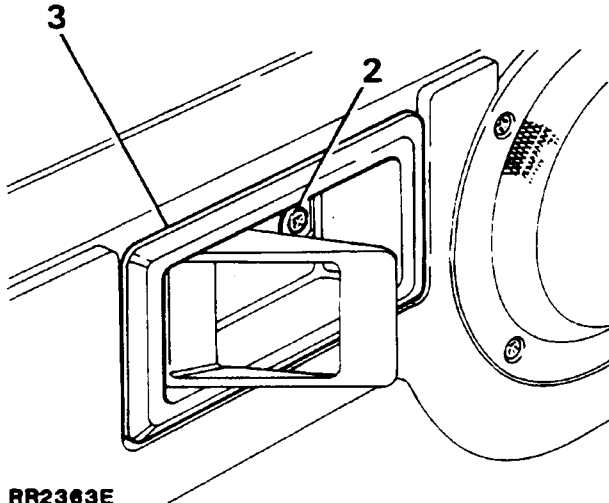

RR2363E

4. Carefully prise the sill locking button bezel from the trim panel.

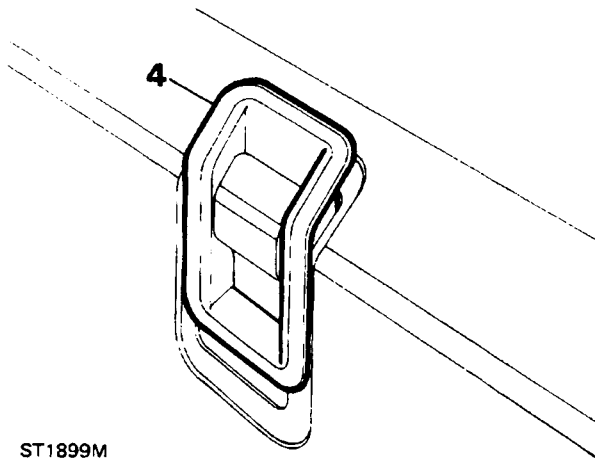

ST1899M

5. Remove the two finisher buttons from the bottom of the door pull pocket to reveal the securing screws.
6. Remove the screws and withdraw the pocket from the trim panel.

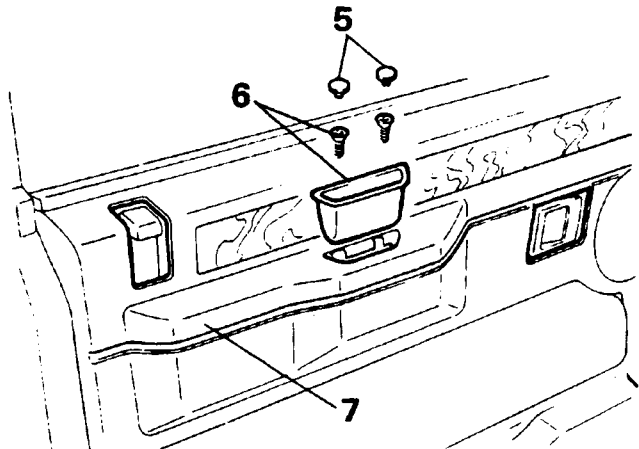

RR2364E

7. Using a screwdriver, carefully prise the trim panel away from the door.

NOTE: Support the trim panel while the speaker leads are disconnected.

8. If necessary the stowage bin front panel can be removed by releasing the screws at the rear of the trim panel.

Refitting

9. Reverse the removal procedure.

Continued

FRONT DOOR LOCK, OUTSIDE AND INSIDE DOOR RELEASE HANDLES - 4 Door models

Remove and refit

Removing

1. Remove the interior door release handle bezel and sill locking button bezel.
2. Remove the two screws from the bottom of the door pull pocket remove the pocket and prise the door trim panel from the door. Disconnect the electrical leads to the door speaker and remove the plastic barrier sheet. Remove the window lift motor. (Refer to the electrical section in main Workshop Manual).
4. Remove the door glass and regulator. (Refer to door glass and regulator remove and refit in main Workshop Manual).
5. Remove the door lock actuator. (Refer to electrical section in main Workshop Manual).
6. Disconnect the control rod from the private key operated lock by releasing the metal clip at the bottom of the rod.
7. Disconnect the control rod from the outside door release handle by pulling it out of the plastic ferrule.
8. Disconnect the control rod connector between the inside door release handle and the door lock by releasing the metal clip and pulling one of the control rods out of the plastic connecting block. This is accessible through the small centre cut - out in the door panel. (The control rod also passes through a guide bracket on the inside of the inner door panel).
9. From inside the door panel push out the small pin which secures the quadrant to the inner door panel. Push the quadrant out of the panel.
10. Remove the two screws securing the sill locking button to the door. Manoeuvre the sill button and remove it from the control rod.
11. Release the door lock by removing the two countersunk screws from the door edge and the single screw with shakeproof washer on the inner door panel.

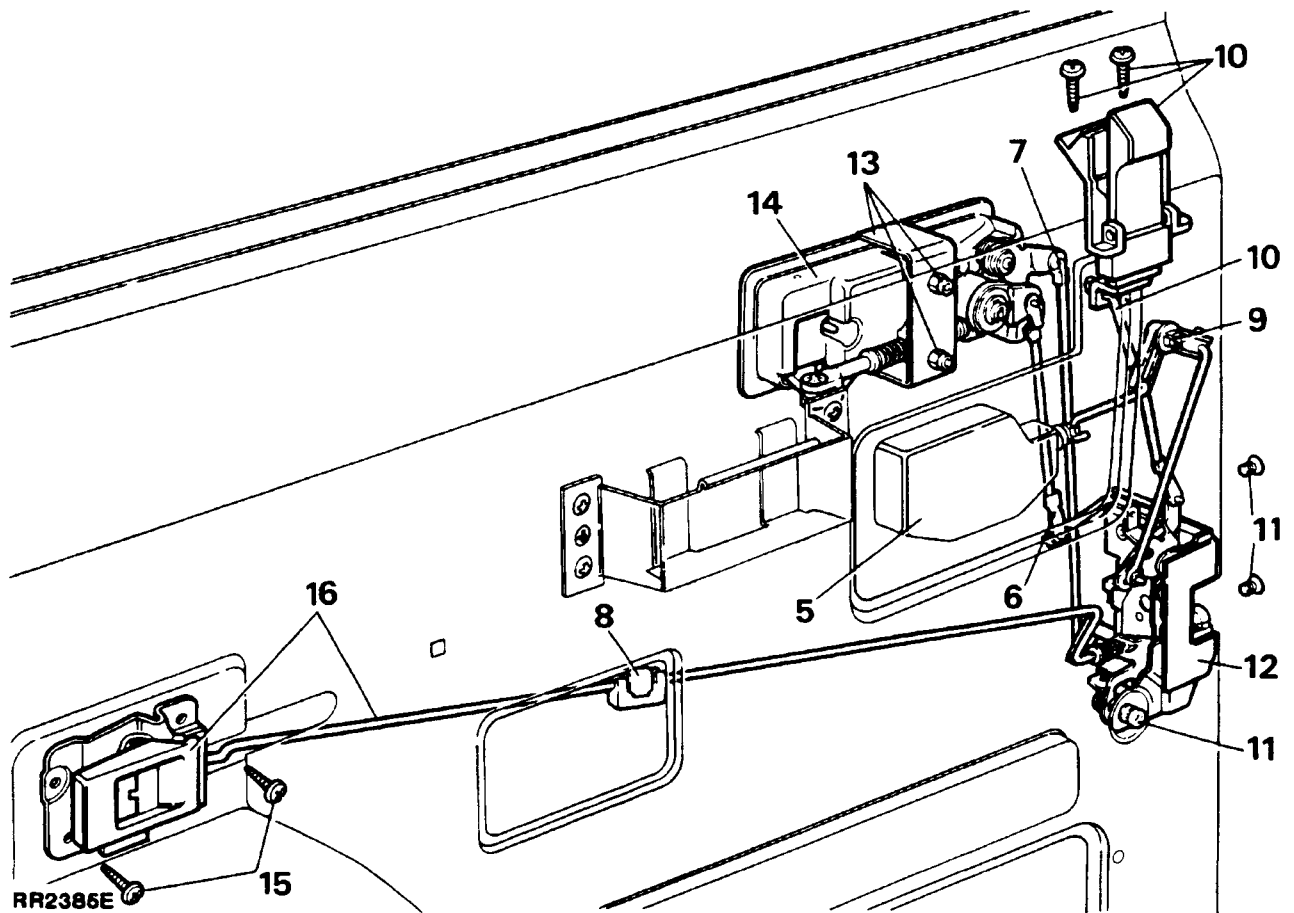

12. Withdraw the lock through the lower rear cut - out on the inner door panel.

NOTE: If necessary the following items can be removed.

13. Remove the two nuts (with shakeproof washers) and retaining bracket securing the **outside release handle** to the outer door panel, accessible through the upper rear cut - out on the inner door panel.
14. Carefully detach the door release handle from the outer door panel.
15. Remove the two screws securing the **inside door release handle** to the inner door panel.
16. Withdraw the handle from its location with half of the connecting rod attached.

Refitting

17. Reverse the removal procedure items 1 to 16.

NOTE: When refitting the door glass frame, ensure that it is positioned to suit the door opening before fully tightening the frame securing bolts.

ADJUSTMENT - FRONT DOOR LOCK AND HANDLE ASSEMBLY - 4 Door models

Inside door release handle to lock

1. Refit the inside door release handle bezel before any adjustment is made, allowing the handle to be set for the correct operating position.
2. Rotate the spring tensioned nyloc nut at the door lock clockwise or counter - clockwise to shorten or extend the operating length of the rod as required.

Outside door release handle to lock

3. Disconnect the connecting rod at the rear of the outer door release handle by releasing the the rod from the plastic ferrule, rotate the rod clockwise or counter - clockwise to shorten or extend the operating length, refit the rod to the ferrule.

NOTE: Door release should be effective before the total handle movement is exhausted to provide a small overthrow movement.

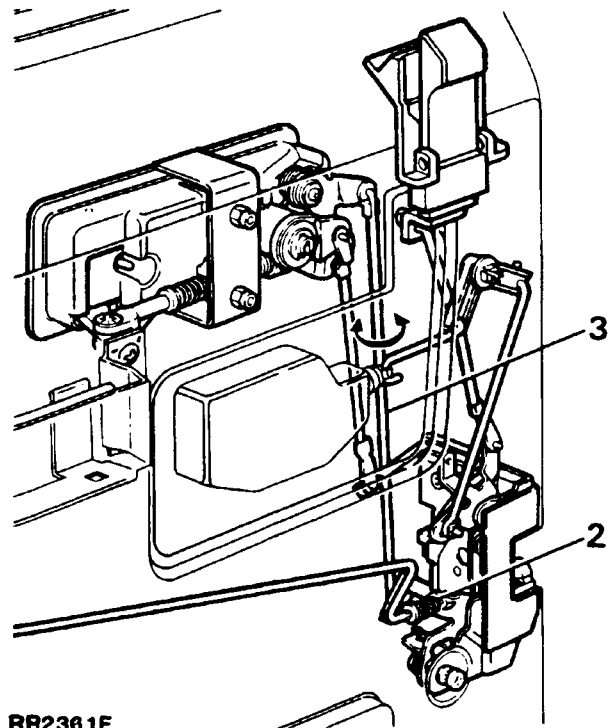

RR2361E

Continued

REAR DOOR - TRIM PANEL - 4 Door models**Remove and refit****Removing**

1. Disconnect the battery negative terminal.
2. Remove the screw securing the handle bezel.
3. Remove the bezel.

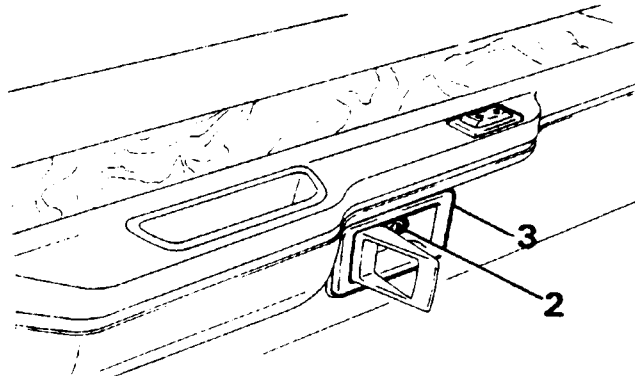

RR2478E

4. Prise the door locking button bezel from the trim panel.

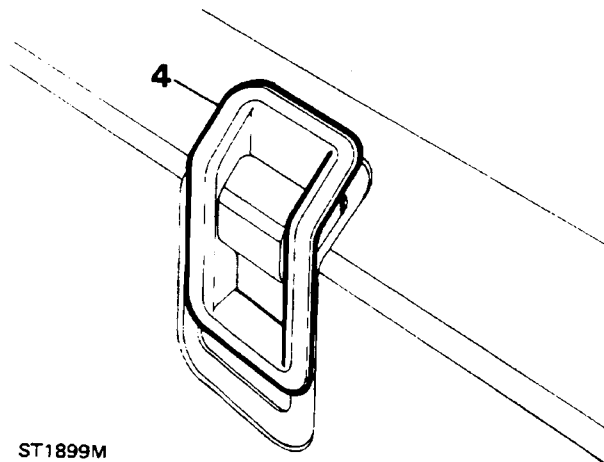

ST1899M

5. Remove the two finisher buttons from the bottom of the door pull pocket to reveal the securing screws.
6. Remove the screws and withdraw the pocket from the trim panel.
7. Using a taped screwdriver, carefully prise the trim panel away from the door.
8. Disconnect the electrical plug from the window lift switch.
9. Remove the window lift switch by pushing from behind the trim panel.

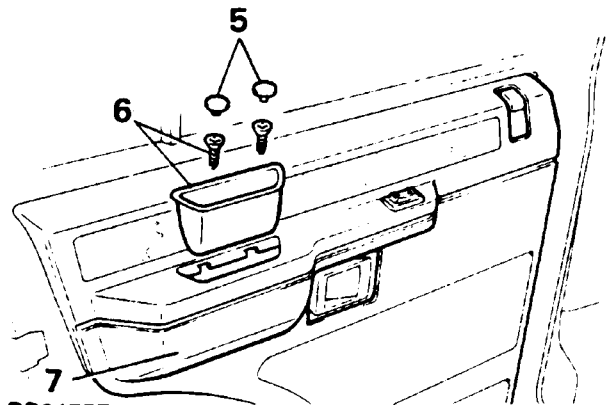

RR2477E

Refitting

10. Reverse the removal instructions.

REAR DOOR LOCK, OUTSIDE AND INSIDE DOOR RELEASE HANDLES - 4 Door models

Remove and refit

Removing

1. Ensure the window is fully closed position and disconnect the battery.
2. Remove the interior door handle bezel, prise the window lift switch from the trim panel and disconnect the electrical multi - plug.
3. Prise the sill button from the trim panel.
4. Remove the two screws from the bottom of the door pull pocket accessible after removing the two buttons and detach the trim panel from the door panel. Remove the plastic barrier sheet.
5. Disconnect the control rod from the inside door release handle by pulling the rod out of its location at the door lock.
6. Disconnect the sill locking control rod from the door lock by releasing the metal clip.
7. Disconnect the control rod from the outside door release handle by pulling it out of the plastic ferrule.

8. Release the door lock by removing the two countersunk screws from the door edge and the single screw (with shakeproof washer) on the inside of the door. Retrieve any spacing washers which may be fitted between the inner door panel and lock.
9. Withdraw the lock through the upper rear opening in the inner door panel.

NOTE: If necessary the following items can also be removed.

10. Remove the two nuts (with shakeproof washers) and retaining bracket securing the outside door release handle accessible through the upper rear cut - out on the inner door panel.
11. Carefully detach the outside door release handle from the outer door panel.
12. Remove the two screws (with plain washers) securing the inside door release handle to the inner door panel.
13. Withdraw the handle from its location with the connecting rod attached.

Continued

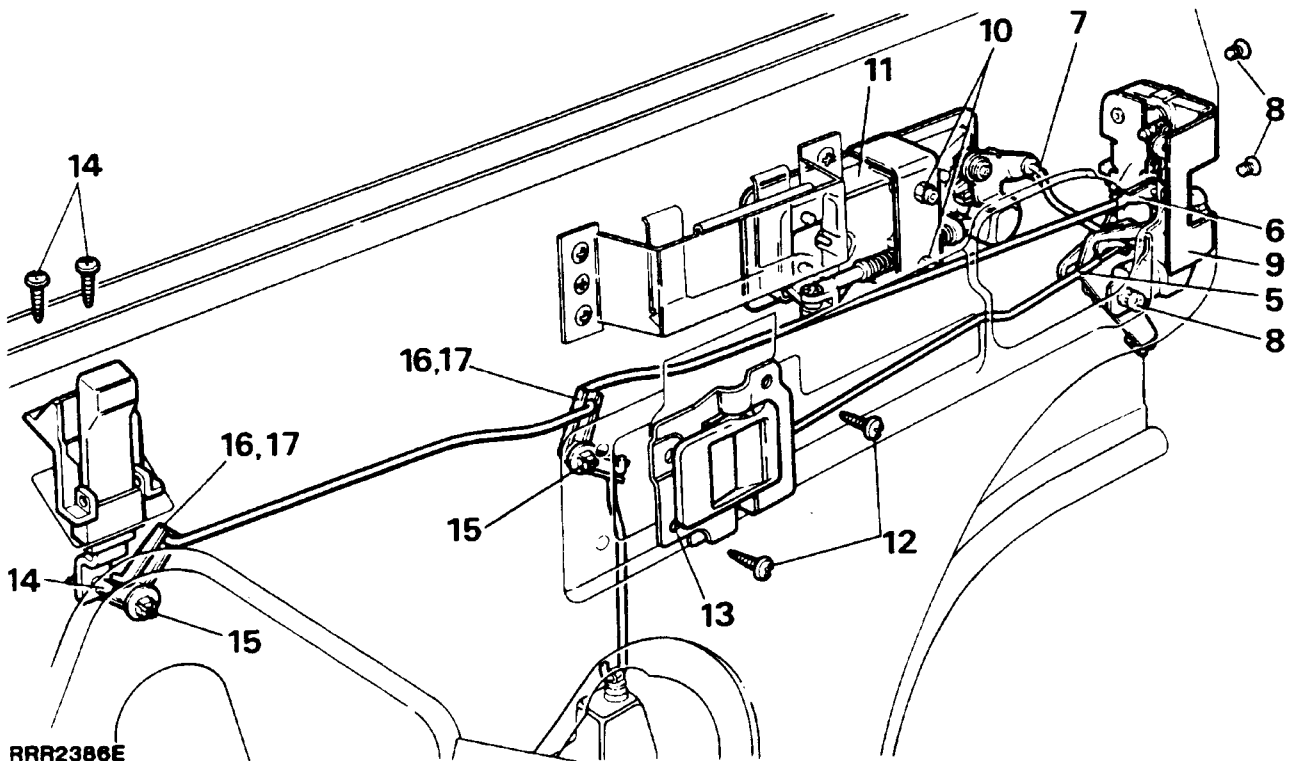

14. Remove the two screws securing the sill locking button to the inner door panel and detach the sill button from the quadrant.

Sill locking quadrants

15. Using a small screwdriver, or 3.175 mm diameter rod, press the plastic locking pins through the respective square inserts in the inner door panel, until they can be retrieved from inside the door.
16. Release the quadrants from the inner door panel and unhook the respective connecting rods.
17. Withdraw the quadrant from the inner door panel.

NOTE: When refitting the quadrants the locking pins are entered into the square insert from outside and pressed in flush.

Refitting

18. Reverse the removal procedure items 1 to 17.

NOTE: When refitting the door glass frame, ensure that it is positioned to suit the door opening before fully tightening the frame securing bolts.

ADJUSTMENT - REAR DOOR LOCK AND HANDLE ASSEMBLY - 4 Door models

Outside door release handle to lock

1. Disconnect the short offset connecting rod at the rear of the door outer release handle, rotate the rod clockwise or counter-clockwise to shorten or extend the operating length of the rod.

NOTE: Door release should be effective before the total handle movement is exhausted to provide a small overthrow movement.

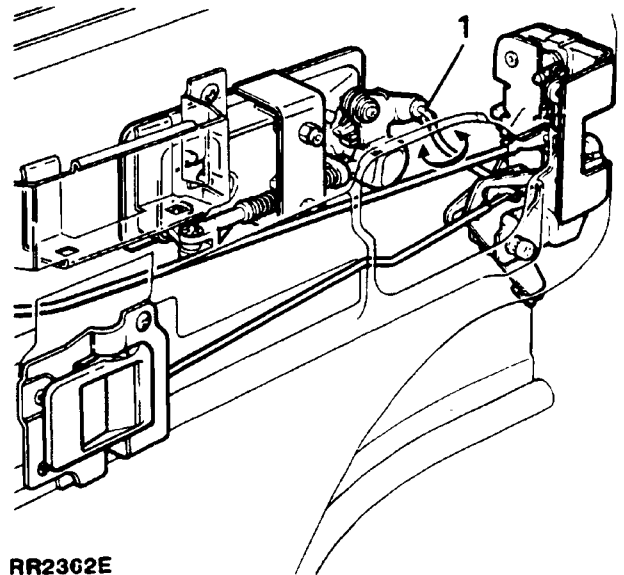

RR2362E

ASYMMETRIC SPLIT REAR SEAT - LOCKING MECHANISM

NOTE: 1989 Model Year vehicles have a revised seat locking mechanism which incorporates a push button release in place of a finger lift button. The revised latch and striker give the seat an improved positive location.

Remove and refit

Removing

1. Depress the seat release button and fold the seat back forward.
2. Unscrew and remove the seat release button.
3. Prise out the two trim buttons securing the trim covering to the latch tower.
4. Manoeuvre the trim covering from the tower.
5. Remove the three screws securing the latch to the tower, noting that access to the single screw is gained through the hole in the front of the tower.
6. Retrieve the latch from the opening at the rear of the tower, also if necessary retrieve the single screw.
7. The operating rod can be removed from the latch by releasing the rod at the plastic clip.

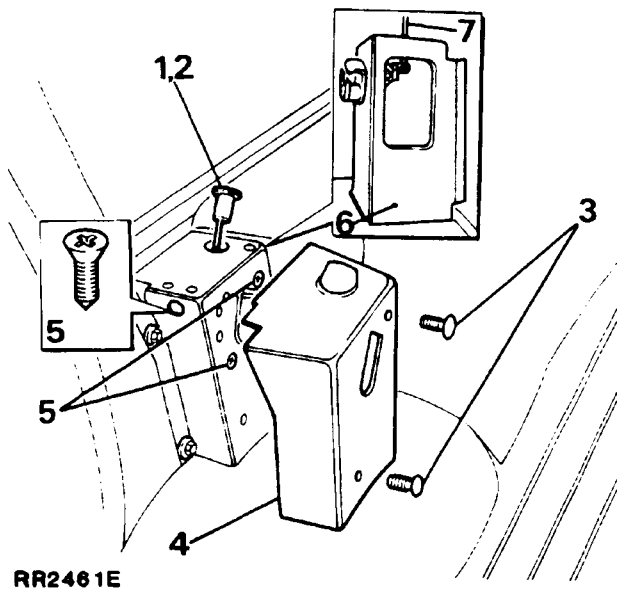

Refitting

8. Refitting is a reversal of the removal procedure noting that when the seat release button is screwed onto the operating rod there must be a gap of 5 - 8 mm (0.196 - 0.312 inch) between the head of the button and lip of the trim covering after the button has been depressed.

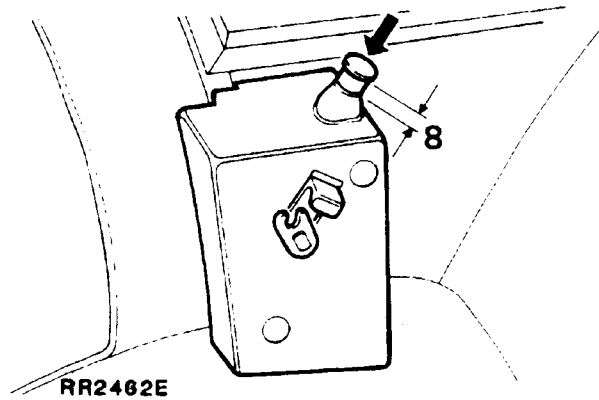

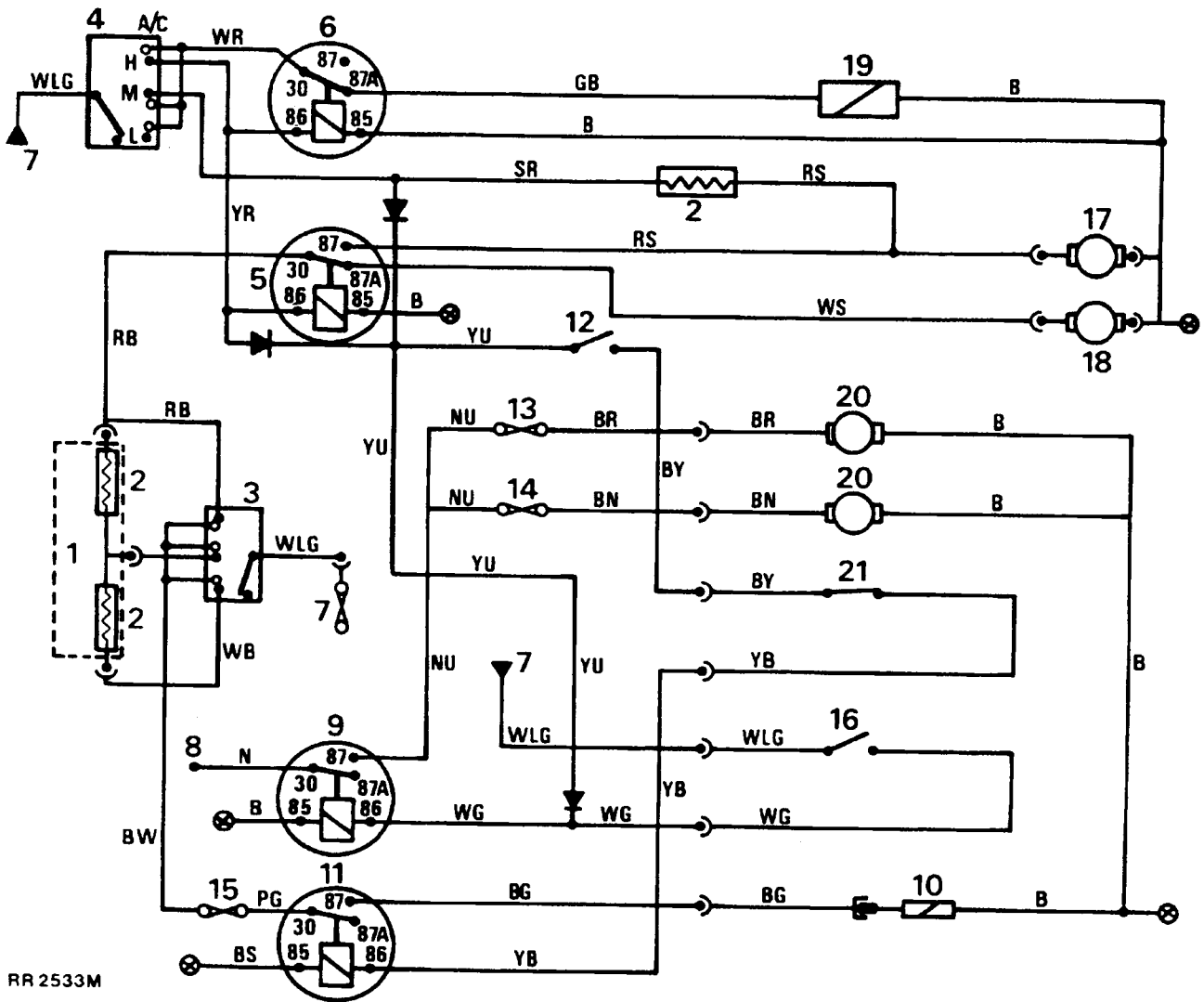

RR 2533M

HEATER AND AIR CONDITIONING - circuit diagram

- | | |
|---|---|
| 1. Heater unit. | 12. Thermostat. |
| 2. Resistors. | 13. Fuse A1-auxiliary fuse panel A. |
| 3. Fan speed switch. | 14. Fuse A2-auxiliary fuse panel A. |
| 4. Air conditioning/re-circ/fresh air switch. | 15. Fuse A3-auxiliary fuse panel A. |
| 5. Air conditioning/heater relay. | 16. Engine water temperature sensor. |
| 6. Fresh air solenoid relay. | 17. Air conditioning motors-(2)-dashboard unit. |
| 7. Fuse 8-main fuse panel. | 18. Heater motor. |
| 8. Main cable connection. | 19. Fresh air solenoid. |
| 9. Fan relay. | 20. Condenser fan motors. |
| 10. Compressor clutch. | 21. High pressure switch. |
| 11. Compressor clutch relay. | |

Cable colour code

B	Black	N	Brown	R	Red	W	White
G	Green	O	Orange	S	Grey	Y	Yellow
L	Light	P	Purple	U	Blue		

The last letter of a colour code denotes the tracer.

HEATED WINDSCREEN WASHER JETS

1989 model year vehicles feature electrically heated windscreen washer jets. The operating thermostat fitted on the righthand headlamp mounting panel senses temperature and will operate the jet heaters at a temperature of $4^{\circ}\text{C} \pm 3^{\circ}\text{C}$.

Washer jets

Remove and refit

Removing

1. Disconnect the battery negative lead.
2. Disconnect the electrical connection at the plug.
3. Withdraw the washer tube from the jet.
4. Push the jet upwards to remove from its mounting.
5. Remove the washer jet mounting from the bonnet, if necessary.

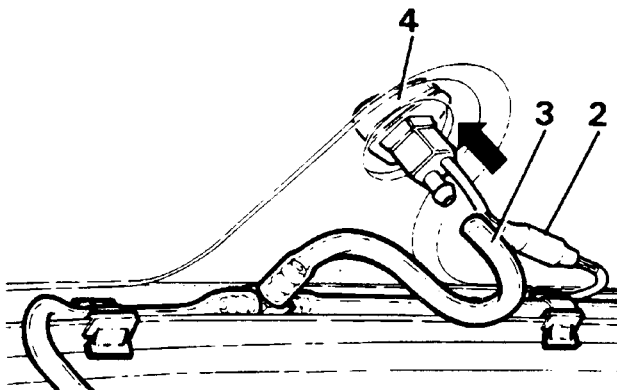

RR2549M

Refitting

6. Reverse the removal procedure.

Thermostat

The thermostat will operate (close) at $4^{\circ}\text{C} \pm 3^{\circ}\text{C}$, and re-open at $10^{\circ}\text{C} \pm 3^{\circ}\text{C}$.

Remove

1. Disconnect the battery negative lead.
2. Remove the radiator grill.
3. Remove two screws securing the thermostat to the right hand headlamp mounting panel.
4. Withdraw the thermostat, disconnecting the electrical connector.

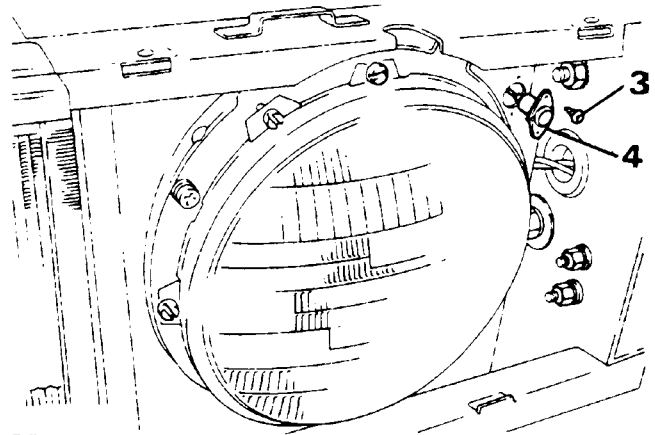

RR2550M

Refitting

5. Reverse the removal procedure.

FUSE BOX

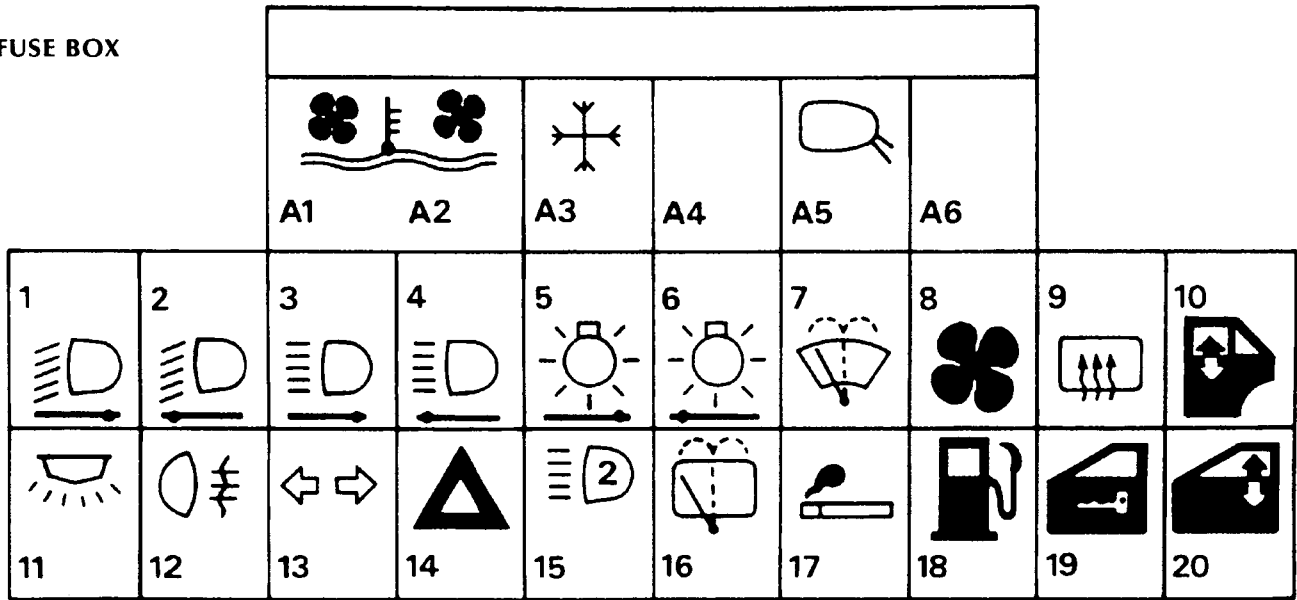

RR2475M

FUSE NO.	COLOUR CODE	FUSE VALUE	CIRCUIT SERVED	IGNITION KEY CONTROLLED
----------	-------------	------------	----------------	-------------------------

MAIN FUSE PANEL

1	Brown	7.5 amp	RH headlamp low beam and power wash	
2	Brown	7.5 amp	LH headlamp low beam	
3	Brown	7.5 amp	RH headlamp high beam	
4	Brown	7.5 amp	LH headlamp high beam, auxiliary lamp switch	
5	Tan	5 amp	RH parking lights and instrument illumination	
6	Tan	5 amp	LH parking lights and radio illumination	
7	Blue	15 amp	Front wash/wiper motors, seat relay, window lift relay, antennae amplifier	Aux
8	Green	30 amp	Heater/air con. motor	Aux
9	White	25 amp	Heated rear screen	Ign
10	Green	30 amp	Window lifts rear-option	Aux
11	Blue	15 amp	Interior light delay, clock, radio, under bonnet illumination	Aux
12	Red	10 amp	Rear fog guard (from dipped-headlamps)	
13	Blue	15 amp	Direction indicators, stop lights, reverse lights, electric mirror pick up point, low coolant, heated jets, interior lamp delay, heater/air con relay	Ign
14	Yellow	20 amp	Hazard lights, horn, headlamps flash	
15	Blue	15 amp	Auxiliary driving lamps	
16	Red	10 amp	Rear wash/wipe motor, heated rear screen switch	Ign
17	Yellow	20 amp	Cigar lighters (front and rear)	Ign
18	Red	10 amp	Fuel pump	Ign
19	Red	10 amp	Central door locking-option	
20	Green	30 amp	Electric window lifts front-option	Aux

NOTE: Radio Cassette combination. An in-line 5 amp fuse is incorporated in the power input lead of the unit.

AUXILIARY FUSE PANEL - (A)

A1	Yellow	20 amp	Air conditioning fan	IGN
A2	Yellow	20 amp	Air conditioning fan	IGN
A3	Tan	5 amp	Air conditioning compressor clutch	IGN
A4			Spare	
A5	Violet	3 amp	Electric mirror motors	IGN
A6			Spare	

AUXILIARY FUSE BOX

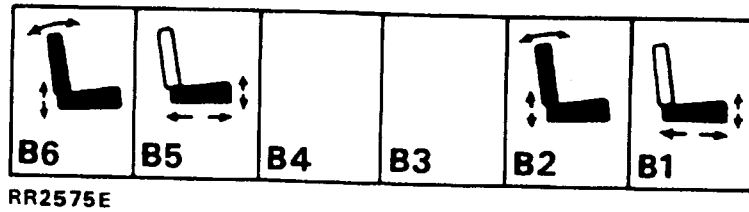

AUXILIARY FUSE BOX (B) - Located under the front left-hand seat

FUSE NO	COLOUR CODE	FUSE VALUE	CIRCUIT SERVED
B1	Green	30 amp	Drivers seat base/height front
B2	Green	30 amp	Drivers seat recline/height rear
B3	----	----	Spare
B4	----	----	Spare
B5	Green	30 amp	Passengers seat base/height front
B6	Green	30 amp	Passengers seat recline/height rear

RELAYS-Identification

RR2547M shows left hand drive configuration of relays.

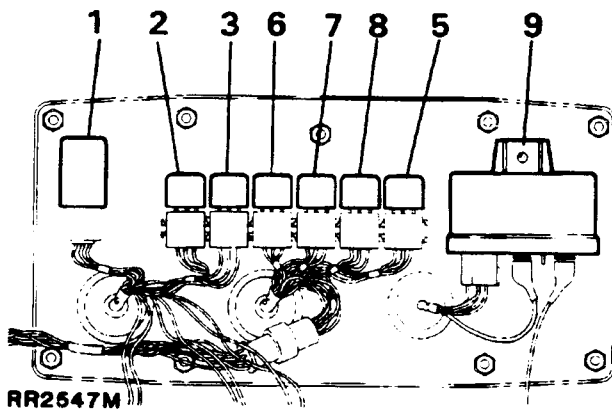

RR2548M shows right hand drive configuration of relays.

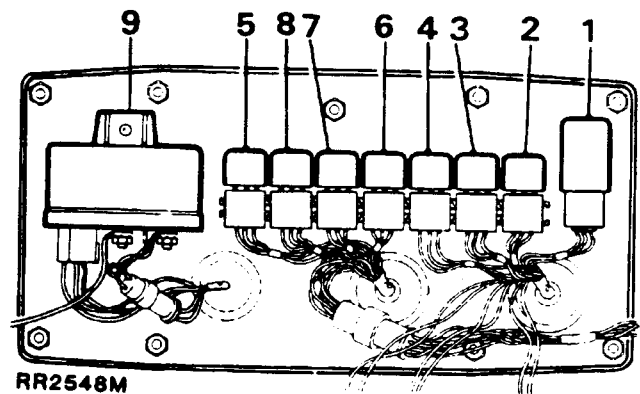

Closure panel viewed from the engine compartment, with protective cover removed.

Relay/delay/timer unit	Main Circuit Diagram Item Number	
	Right hand steer	Left hand steer Non-catalyst
1. Headlamp wash timer unit	19. M	17. M
2. Heated rear window relay	66. M	64. M
3. Starter solenoid relay	6. M	6. M
4. Brake check relay	151. M	157. M
5. Fresh air solenoid relay	6. A	6. A
6. Compressor clutch relay	10. A	10. A
7. Condenser fan relay	9. A	9. A
8. Air conditioning/heater	5. A	5. A
9. Glow plug timer unit (Diesel models)	143. M	150. M
10. Rear wiper delay	132. M	139. M
11. Auxiliary lamp relay (if fitted)	88. M	86. M
12. Ignition load relay	1. M	1. M
13. Headlamp relay	157. M	26. M
14. Heater/air con. relay	163. M	175. M
15. Interior lamp delay	101. M	99. M
16. Flasher/hazard unit	75. M	73. M
17. Voltage sensitive switch (air conditioning)	72. M	70. M
18. Front wiper delay	15. M	14. M
19. Seat adjustment relay, two (if fitted)	5/6. S	5/6. S
20. Main EFI relay	10. E	10. E
21. Fuel pump relay	11. E	11. E
22. Sunshine roof auxiliary relay (if fitted)	3. SR	3. SR
23. Rear window lift relay (if fitted)	13. W	13. W
24. Front window lift relay (if fitted)	14. W	14. W
25. Window lift one touch unit (if fitted)	1. W	1. W

M = Main circuit diagram

A = Air conditioning circuit diagram

S = Seat adjustment circuit diagram

E = EFI circuit diagram

SR = Sunroof circuit diagram

W = Window lift circuit diagram

NOTE: The brake check relay on left hand drive vehicles is situated inside the lower fascia panel.

NOTE: Refer to fuel injection section of manual for full information on E.F.I. relays.

Saudi vehicles are fitted with two extra relays, an overspeed monitor and buzzer, located immediately below the instrument binnacle.

Access to the two units is gained by removing the lower dash panel and steering column shroud.

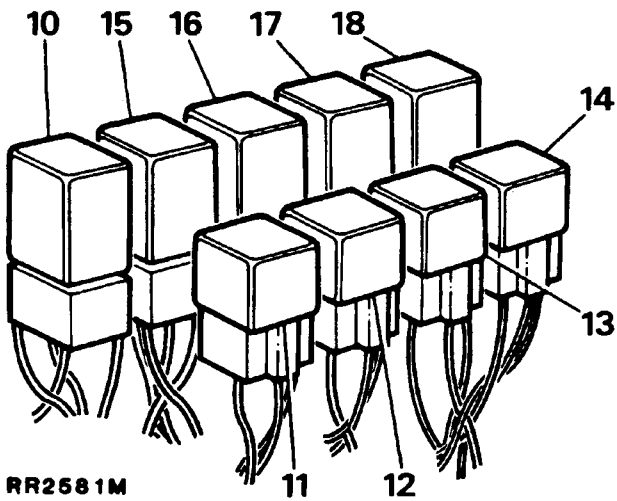

Steering column mounted relays viewed with the lower dash panel removed.

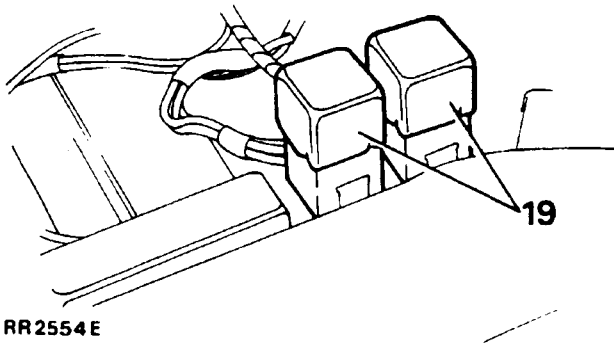

Seat adjustment relay (load control) located beneath the left hand front seat adjacent to fuse box (B).

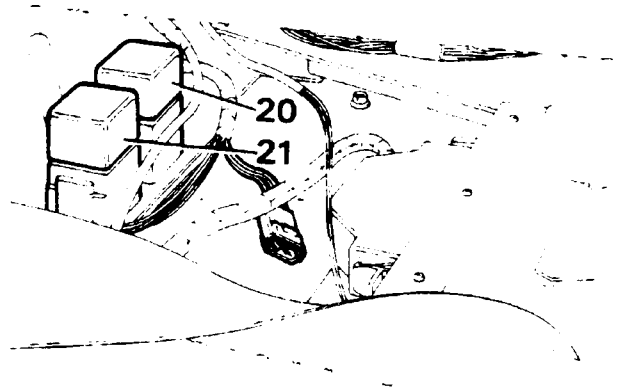

RR2374V

Main EFI (black terminal block) and fuel pump relays (blue terminal block) mounted beneath right hand front seat.

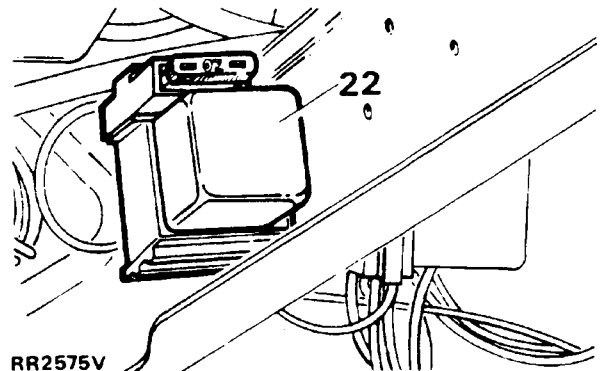

Sunshine roof auxiliary relay located on side of the steering column support bracket located behind the lower dash panel. (Left hand drive shown).

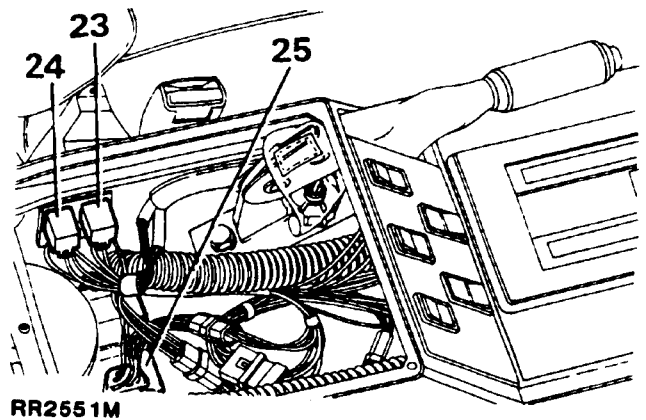

Front (black terminal block) and rear (blue terminal block) window relays. One touch control unit (25) is located inside the glove box, accessible by removing glove box liner.

ELECTRICALLY OPERATED CENTRAL DOOR LOCKING SYSTEM

The optional central door locking system now includes an actuator unit to lock the upper tailgate.

Locking or unlocking the drivers door from outside by key operation, or from inside by sill knob automatically locks or unlocks all four doors, the upper tailgate and the fuel filler flap.

Front and rear passenger doors can be independently locked or unlocked from inside the vehicle by sill knob operation but can be overridden by further operation of the driver locking control.

On rear doors only a child safety lock is provided which can be mechanically pre-set to render the interior door handles inoperative.

Failure of an actuator will not affect the locking of the remaining three doors, tailgate or fuel filler flap. The door/tailgate with the inoperative actuator can still be locked or unlocked manually, but not the fuel filler flap.

It is also possible to override the tailgate central locking by use of the key.

NOTE: The door lock actuator units contain non-serviceable parts. If a fault should occur replace the unit concerned with a new one.

Before carrying out any maintenance work disconnect the battery.

UPPER TAILGATE ACTUATOR UNIT

Remove and refit

Removing

1. Remove two screws and the trim covering to gain access to the actuator.
2. Disconnect the electrical connection.
3. Remove the two actuator retaining screws.
4. Manoeuvre the actuator assembly to detach the operating rod 'eye' from the actuator link to the lock.
5. Withdraw the tailgate actuator unit.

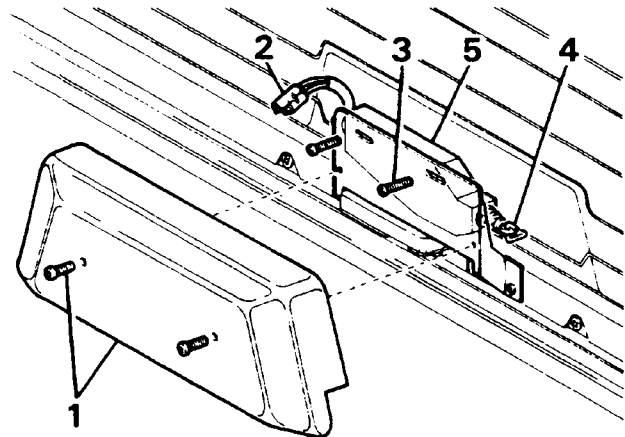

RR2570E

Refitting

6. Reverse the removal procedure.
7. Check the operation of the central locking system.

ELECTRICAL EQUIPMENT - CIRCUIT DIAGRAMS - 1989 Model year

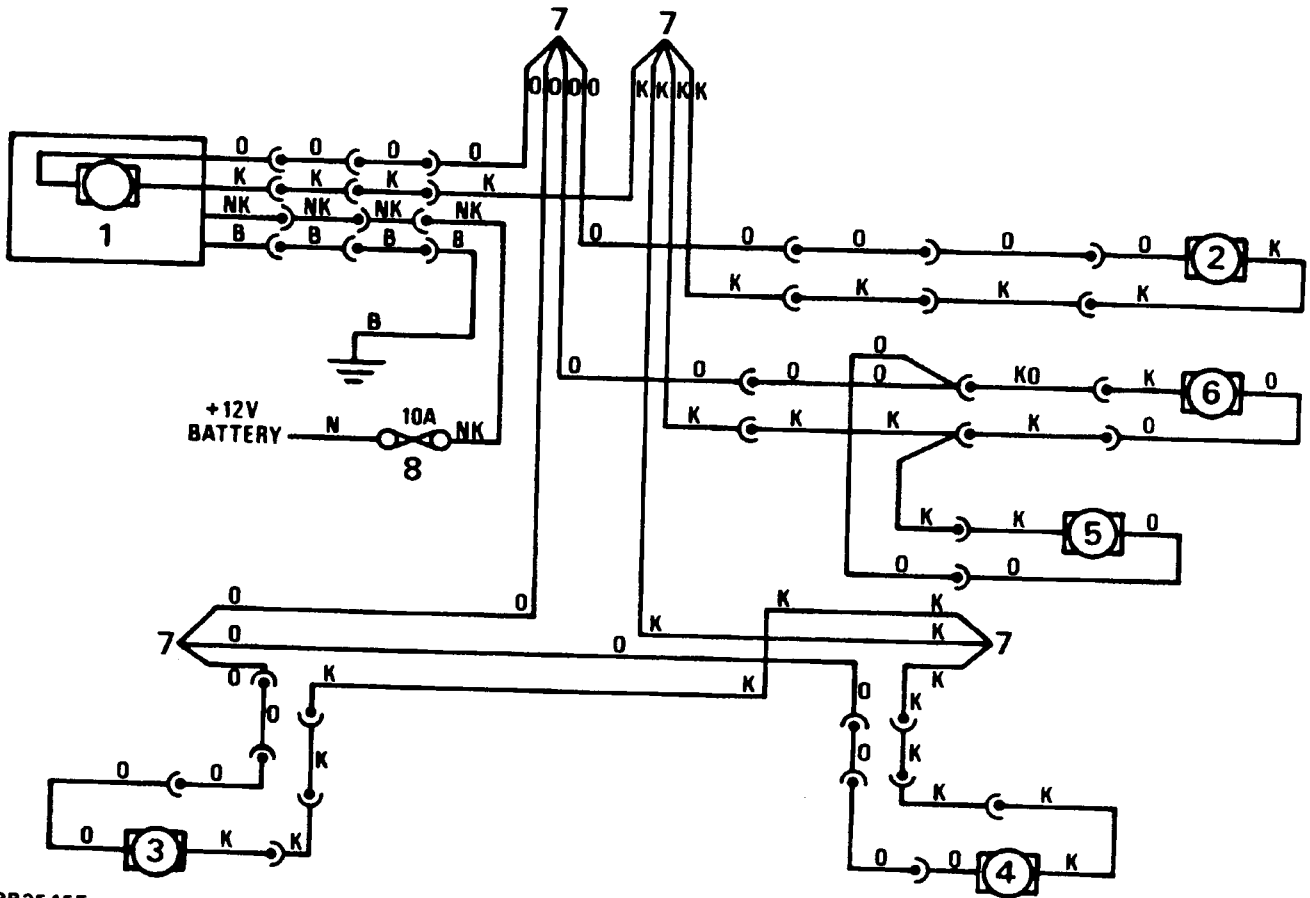

RR2545E

CENTRAL DOOR LOCKING - Circuit diagram RR2545E

1. Switch/lock unit drivers door
2. Lock unit front passenger door
3. Lock unit-left hand rear door
4. Lock unit-right hand rear door
5. Fuel flap actuator
6. Lock unit-tailgate
7. Clinches
8. Fuse 19

Cable colour code

B Black	L Light	P Purple	U Blue
G Green	N Brown	R Red	W White
K Pink	O Orange	S Grey	Y Yellow

The last letter of a colour code denotes the tracer.

ELECTRIC SEAT ADJUSTMENT

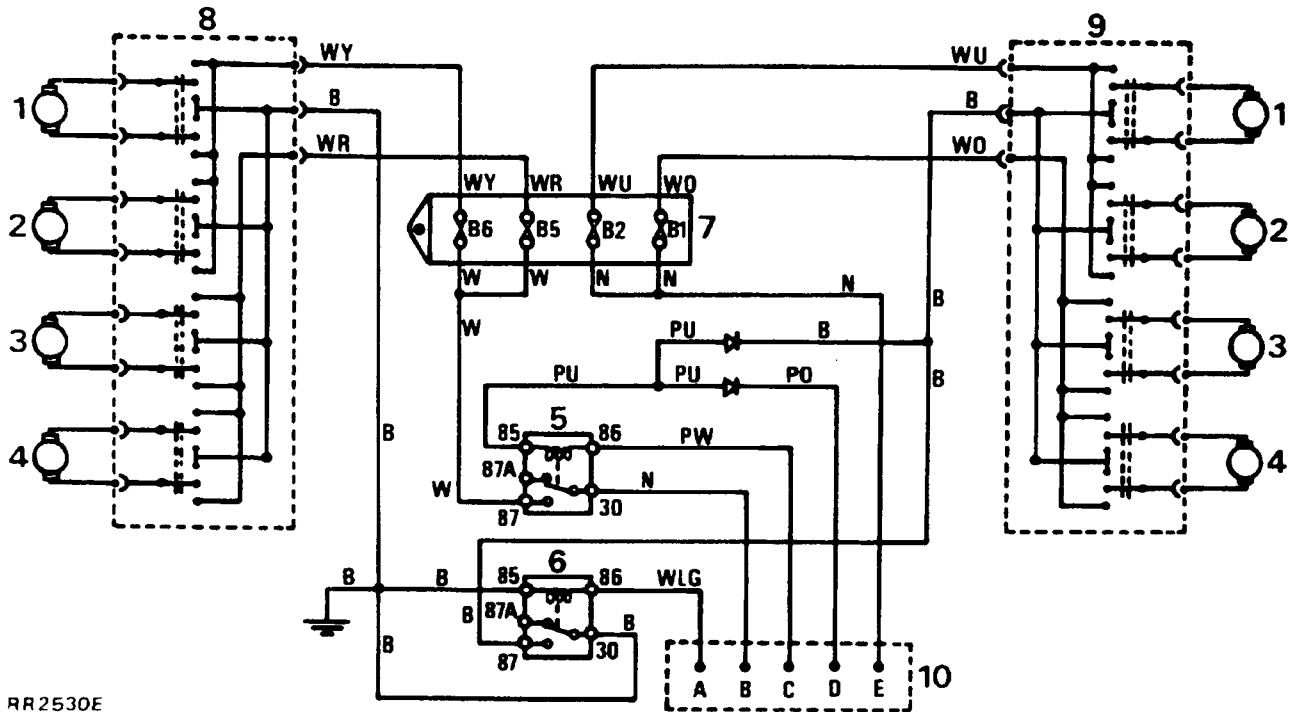

Circuit diagram - RR2530E

1. Seat recline motor
2. Seat height (rear) motor
3. Seat base adjust motor
4. Seat height (front) motor
5. Load relay-from driver's door courtesy switch
6. Load relay-fused auxiliary feed controlled
7. Auxiliary fuse box (B)
8. Driver's seat control
9. Passenger's seat control
10. Main cable connections:
 - A: Fused auxiliary feed
 - B: Battery feed
 - C: Fused 12 volt
 - D: Courtesy switch earth
 - E: Battery feed

Cable colour code

B Black	G Green	P Purple	Y Yellow
U Blue	S Grey	R Red	L Light
N Brown	O Orange	W White	

The last letter of a colour code denotes the tracer.

ELECTRIC WINDOW LIFT**Circuit diagram - RR2531E**

1. One touch control unit-drivers window
2. Window lift motor-drivers window
3. Window lift motor-front passengers side
4. Window lift motor LH rear
5. Window lift motor RH rear
6. Window lift switch drivers window
7. Window lift switch front passengers window
8. Window lift switch LH rear door
9. Window lift switch RH rear door
10. Isolator switch
11. Window lift switch in LH rear door
12. Window lift switch in RH rear door
13. Relay-rear windows
14. Relay-front windows
15. Clinches
16. Main cable fuses
 - a: Fuse 10
 - b: Fuse 20
 - c: Fuse 7

Cable colour code

B Black	L Light	P Purple	U Blue
G Green	N Brown	R Red	W White
K Pink	O Orange	S Grey	Y Yellow

The last letter of a colour code denotes the tracer.

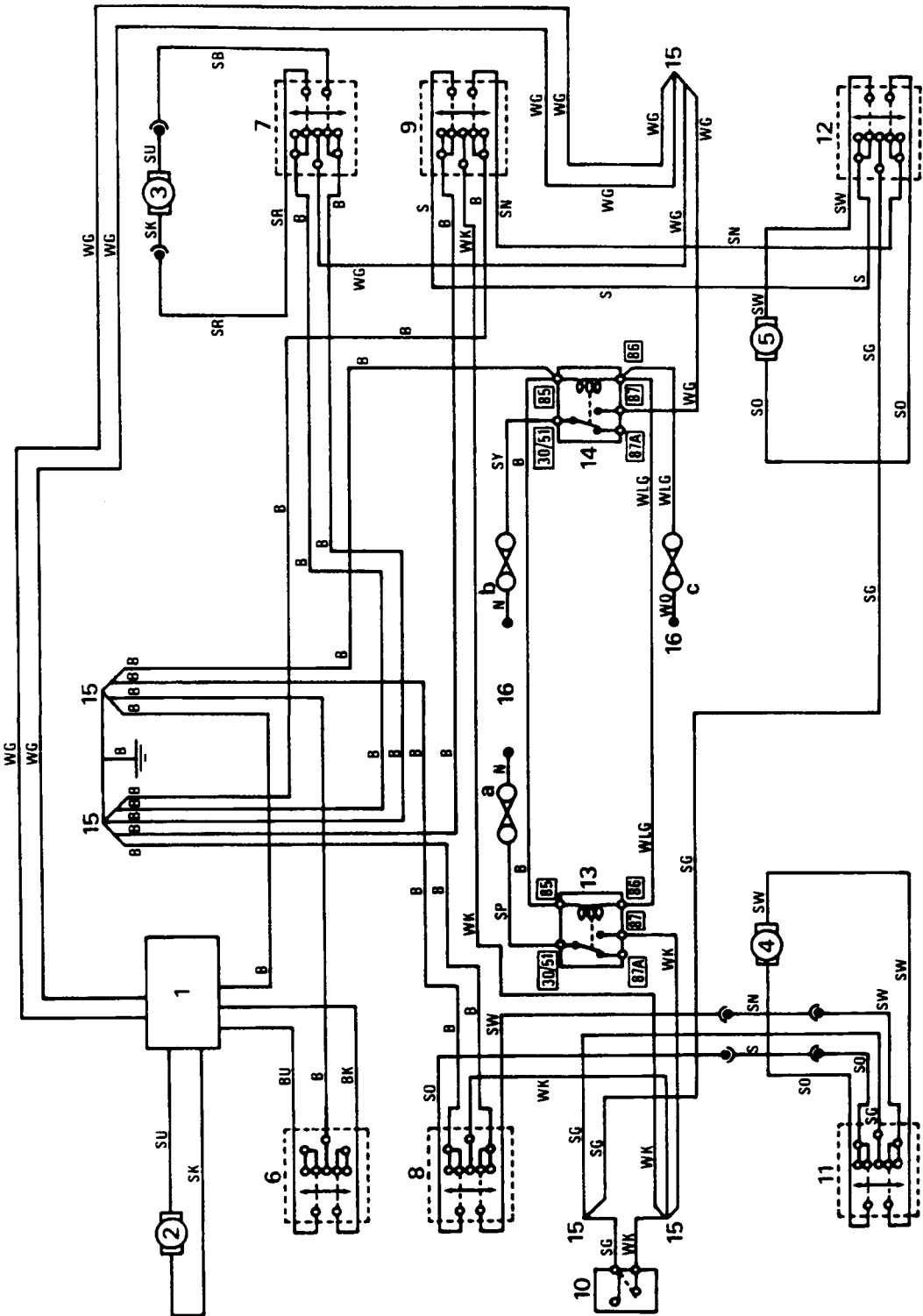

RR2531E

MAIN CIRCUIT DIAGRAM

Right Hand Steering - RR2571M & RR2572M

Numerical key

1.	Ignition load relay	59.	LH horn	119.	Ignition coil (petrol models)
2.	Battery	60.	Under bonnet light switch	120.	Capacitor (petrol models)
3.	Terminal post	61.	Under bonnet light	121.	Distributor (petrol models)
4.	Starter solenoid	62.	Clock	122.	EFI harness plug
5.	Starter motor	63.	Fuse 19	123.	Fuel shut off solenoid (Diesel)
6.	Starter relay	64.	Fuse 20	124.	Not used
7.	Starter inhibit switch (Automatic)	65.	Pick-up point central locking/window lift (option)	125.	Radio fuse
8.	Ignition switch	66.	Heated rear window relay	126.	Radio and four speakers
9.	Tachometer	67.	Fuse 9	- LF-left hand front speaker	
10.	Voltage transformer(dim dip)	68.	Radio aerial amplifier	- LR-left hand rear speaker	
11.	Ignition warning lamp	69.	Heated rear screen	- RF-right hand front speaker	
12.	Alternator	70.	Heated rear screen switch	- RR-right hand rear speaker	
13.	Fuse 7	71.	Heated rear screen warning lamp	127.	Sun roof pick up point (option)
14.	Front wipe/wash switch	72.	Voltage sensitive switch	128.	Automatic transmission oil temperature warning lamp
15.	Front wipe delay unit	73.	Fuse 13	129.	Automatic transmission oil temperature warning lamp
16.	Front wiper motor	74.	Hazard switch	130.	Fuse 16
17.	Front wash switch	75.	Flasher unit	131.	Rear wash wipe switch
18.	Front wash pump	76.	Direction indicator switch	132.	Rear wipe delay unit
19.	Headlamp wash timer unit (option)	77.	Hazard/indicator warning lamp	133.	Rear wiper motor
20.	Headlamp wash pump (option)	78.	LH rear indicator lamp	134.	Rear screen wash pump
21.	Main lighting switch	79.	LH front indicator lamp	135.	Low screen wash fluid level warning lamp
22.	Fuse 6	80.	LH side repeater lamp	136.	Low screen wash switch
23.	Fuse 5	81.	RH side repeater lamp	137.	Low coolant switch
24.	LH side lamp	82.	RH front indicator lamp	138.	Multi-function unit in binnacle
25.	LH tail lamp	83.	RH rear indicator lamp	139.	Low coolant level warning lamp
26.	LH number plate lamp	84.	Trailer warning lamp	140.	Low fuel level warning lamp
26b.	RH number plate lamp	85.	Fuse 15	141.	Cold start/diesel glow plug warning lamp
27.	Main beam dip/flash switch	86.	Stop lamp switch	142.	Cold start switch (carburetter)
28.	Fuse 14	87.	Reverse lamp switch	143.	Glow plug timer (diesel)
29.	RH side lamp	88.	Auxiliary lamp relay (option)	144.	Glow plugs (diesel)
30.	RH tail lamp	89.	LH stop lamp	145.	Handbrake warning lamp
31.	Rheostat	90.	RH stop lamp	146.	Brake fail warning lamp
32.	Fuse 3	91.	LH reverse lamp	147.	Handbrake warning switch
33.	Fuse 4	92.	RH reverse lamp	148.	Brake fluid level warning switch
34.	Fuse 1	93.	LH auxiliary lamp (option)	149.	Brake pad wear warning lamp
35.	Fuse 2	94.	RH auxiliary lamp (option)	150.	Brake pad wear sensors
36.	Rear fog switch	95.	Auxiliary lamp switch (option)	151.	Brake check relay
37.	Fuse 12	96.	Fuse 17	152.	Split charge relay (option)
38.	Switch illumination (2 off)	97.	Dash cigar lighter	153.	Split charge terminal post (option)
39.	Cigar lighter illumination (2 off)	98.	Cubby box cigar lighter	154.	Heater/air conditioning connections
40.	Heater illumination (4 off)	99.	Front interior lamp	155.	Fuse 8
41.	Clock illumination	100.	Rear interior lamp	156.	Coil negative (engine RPM input to ECU)
42.	Automatic gear selector illumination (2 off)	101.	Interior lamp delay unit	157.	Headlamp relay
43.	Instrument illumination (6 off)	102.	LH door edge lamp	158.	Ignition load relay (+)
43b.	Column switch illumination	103.	LH puddle lamp	159.	Battery feed (+)
44.	Rear fog warning lamp	104.	RH door edge lamp	160.	Ignition auxiliary (+)
45.	LH rear fog	105.	RH puddle lamp	161.	Ignition on (+)
46.	RH rear fog	106.	Interior lamp switch	162.	Earth (-)
47.	LH dip beam	107.	LH rear door switch	163.	Heater/air con relay
48.	RH dip beam	108.	RH rear door switch	164.	Trailer pick up point
49.	LH main beam	109.	Tailgate switch	165.	Electric seats pick up point (option)
50.	RH main beam	110.	LH front door switch	166.	Fuse 10
51.	Main beam warning lamp	111.	RH front door switch	167.	Electric mirrors pick up point (option)
52.	Fuel gauge	112.	Heated jets	168.	Alarm connection (dealer fit)
53.	Fuel gauge sender unit	113.	Thermostat heated jets		
54.	Water temperature gauge	114.	Oil pressure warning lamp		
55.	Water temperature sender unit	115.	Oil pressure switch		
56.	Fuse 11	116.	Fuse 18		
57.	Horn switch	117.	Fuel cut off relay (carburetter models)		
58.	RH horn	118.	Fuel pump (petrol models)		

CABLE COLOUR CODE

B	Black	L	Light	P	Purple	U	Blue
G	Green	N	Brown	R	Red	W	White
K	Pink	O	Orange	S	Grey	Y	Yellow

The last letter of a colour code denotes the tracer.

MAIN CIRCUIT DIAGRAM

Right Hand Steering - RR2571M & RR2572M

Alphabetical key

168.	Alarm connection (dealer fit)	96.	Fuse 17	27.	Main beam dip/flash switch
12.	Alternator	116.	Fuse 18	51.	Main beam warning lamp
42.	Automatic gear selector illumination (2 off)	63.	Fuse 19	21.	Main lighting switch
129.	Automatic transmission oil temperature switch	64.	Fuse 20	138.	Multi-function unit in binnacle
128.	Automatic transmission oil temperature warning lamp	52.	Fuel gauge	115.	Oil pressure switch
88.	Auxiliary lamp relay (option)	53.	Fuel gauge sender unit	114.	Oil pressure warning lamp
95.	Auxiliary lamp switch (option)	118.	Fuel pump (petrol models)	65.	Pick-up point central locking/window lift (option)
2.	Battery	123.	Fuel shut off solenoid (Diesel)	68.	Radio aerial amplifier
159.	Battery feed (+)	144.	Glow plugs (diesel)	126.	Radio and four speakers
151.	Brake check relay	143.	Glow plug timer (diesel)	125.	Radio fuse
146.	Brake fail warning lamp	145.	Handbrake warning lamp	36.	Rear fog switch
148.	Brake fluid level warning switch	147.	Handbrake warning switch	44.	Rear fog warning lamp
150.	Brake pad wear sensors	77.	Hazard/indicator warning lamp	100.	Rear interior lamp
149.	Brake pad wear warning lamp	74.	Hazard switch	134.	Rear screen wash pump
120.	Capacitor (petrol models)	157.	Headlamp relay	131.	Rear wash wipe switch
39.	Cigar lighter illumination (2 off)	20.	Headlamp wash pump (option)	132.	Rear wipe delay unit
62.	Clock	19.	Headlamp wash timer unit (option)	133.	Rear wiper motor
41.	Clock illumination	112.	Heated jets	87.	Reverse lamp switch
156.	Coil negative (engine RPM input to ECU)	69.	Heated rear screen	31.	Rheostat
141.	Cold start/diesel glow plug warning lamp	70.	Heated rear screen switch	94.	RH auxiliary lamp (option)
142.	Cold start switch (carburettor)	71.	Heated rear screen warning lamp	48.	RH dip beam
43b.	Column switch illumination	66.	Heated rear window relay	104.	RH door edge lamp
98.	Cubby box cigar lighter	154.	Heater/air conditioning connections	111.	RH front door switch
97.	Dash cigar lighter	163.	Heater/air con relay	82.	RH front indicator lamp
76.	Direction indicator switch	40.	Heater illumination (4 off)	58.	RH horn
121.	Distributor (petrol models)	57.	Horn switch	50.	RH main beam
162.	Earth (-)	160.	Ignition auxiliary (+)	26b.	RH number plate lamp
122.	EFI harness plug	119.	Ignition coil (petrol models)	105.	RH puddle lamp
167.	Electric mirrors pick up point (option)	43.	Instrument illumination (6 off)	108.	RH rear door switch
165.	Electric seats pick up point (option)	101.	Interior lamp delay unit	46.	RH rear fog
75.	Flasher unit	106.	Interior lamp switch	83.	RH rear indicator lamp
99.	Front interior lamp	1.	Ignition load relay	92.	RH reverse lamp
17.	Front wash switch	158.	Ignition load relay (+)	29.	RH side lamp
18.	Front wash pump	161.	Ignition on (+)	81.	RH side repeater lamp
15.	Front wipe delay unit	8.	Ignition switch	90.	RH stop lamp
16.	Front wiper motor	11.	Ignition warning lamp	30.	RH tail lamp
14.	Front wipe/wash switch	139.	Low coolant level warning lamp	152.	Split charge relay (option)
117.	Fuel cut off relay (carburettor models)	137.	Low coolant switch	153.	Split charge terminal post (option)
34.	Fuse 1	140.	Low fuel level warning lamp	7.	Starter inhibit switch (Automatic)
35.	Fuse 2	135.	Low screen wash fluid level warning lamp	5.	Starter motor
32.	Fuse 3	136.	Low screen wash switch	6.	Starter relay
33.	Fuse 4	93.	LH auxiliary lamp (option)	4.	Starter solenoid
23.	Fuse 5	47.	LH dip beam	86.	Stop lamp switch
22.	Fuse 6	102.	LH door edge lamp	127.	Sun roof pick up point (option)
13.	Fuse 7	110.	LH front door switch	38.	Switch illumination (2 off)
155.	Fuse 8	79.	LH front indicator lamp	9.	Tachometer
67.	Fuse 9	59.	LH horn	109.	Tailgate switch
166.	Fuse 10	49.	LH main beam	3.	Terminal post
56.	Fuse 11	26.	LH number plate lamp	113.	Thermostat heated jets
37.	Fuse 12	103.	LH puddle lamp	164.	Trailer pick up point
73.	Fuse 13	107.	LH rear door switch	84.	Trailer warning lamp
28.	Fuse 14	45.	LH rear fog	61.	Under bonnet light
85.	Fuse 15	78.	LH rear indicator lamp	60.	Under bonnet light switch
130.	Fuse 16	91.	LH reverse lamp	72.	Voltage sensitive switch
		24.	LH side lamp	10.	Voltage transformer(dim dip)
		80.	LH side repeater lamp	54.	Water temperature gauge
		89.	LH stop lamp	55.	Water temperature sender unit
		25.	LH tail lamp		

86 ELECTRICAL EQUIPMENT

MAIN CIRCUIT DIAGRAM Right hand steering - RR2571M & RR2572M

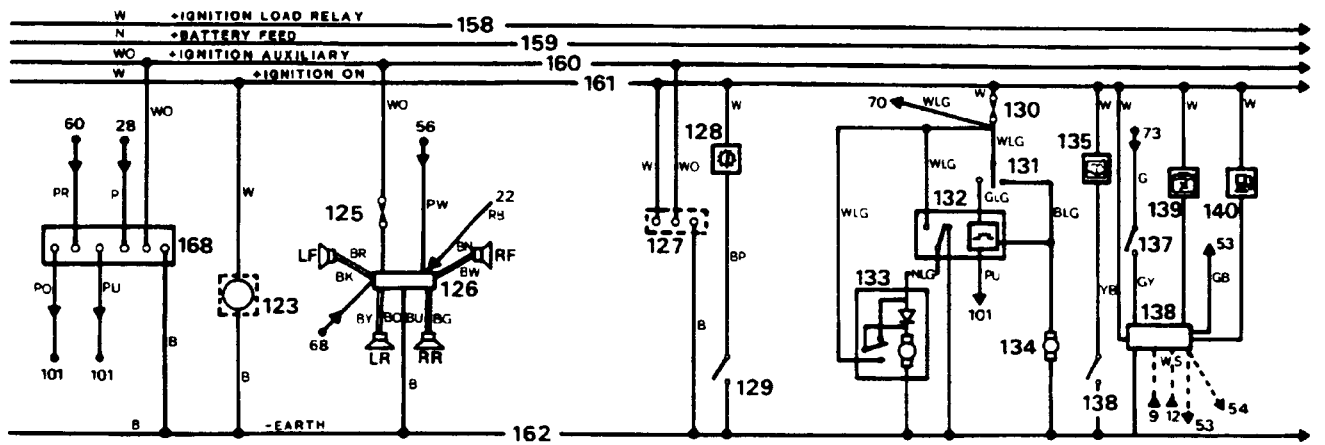
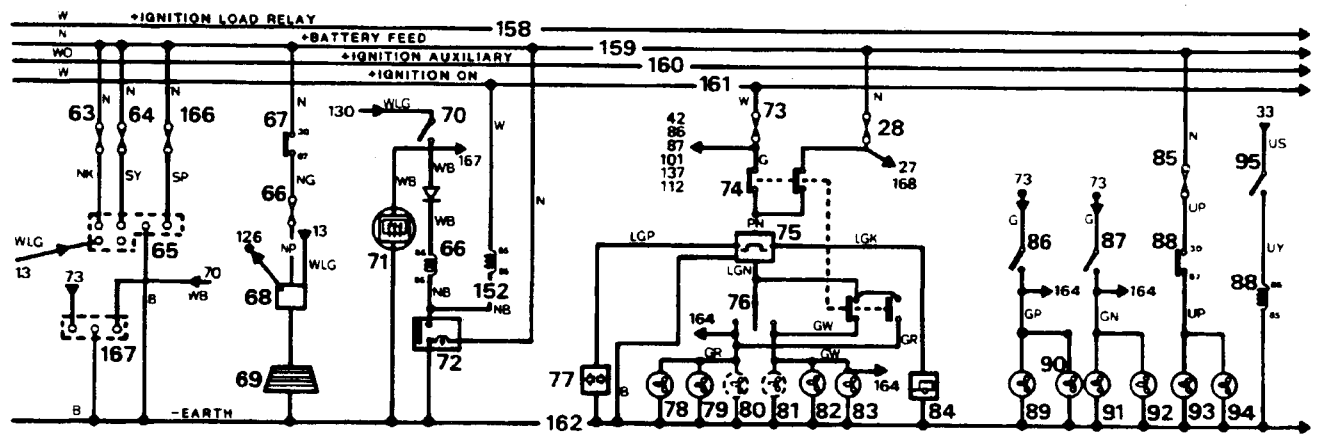
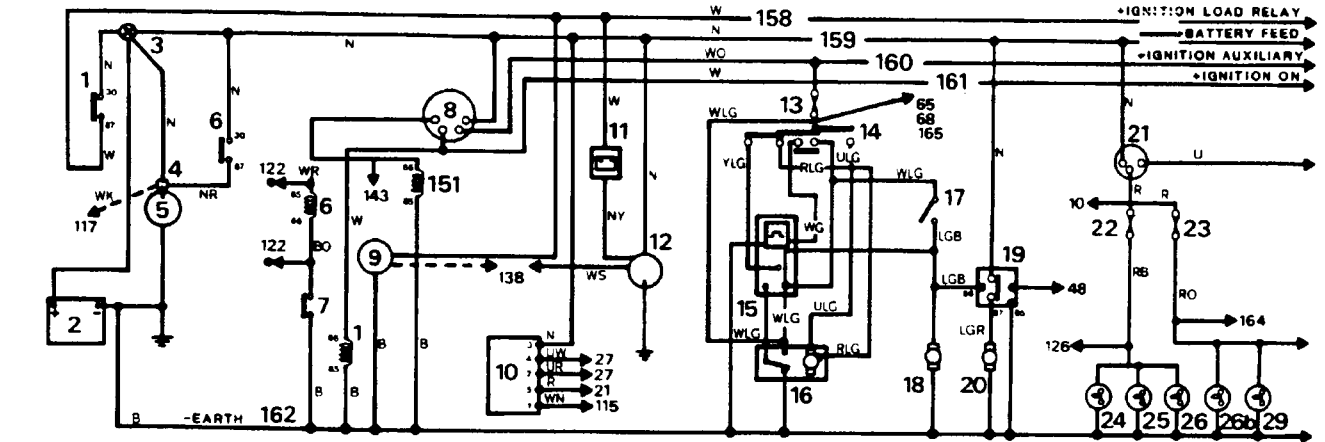

RR2571M

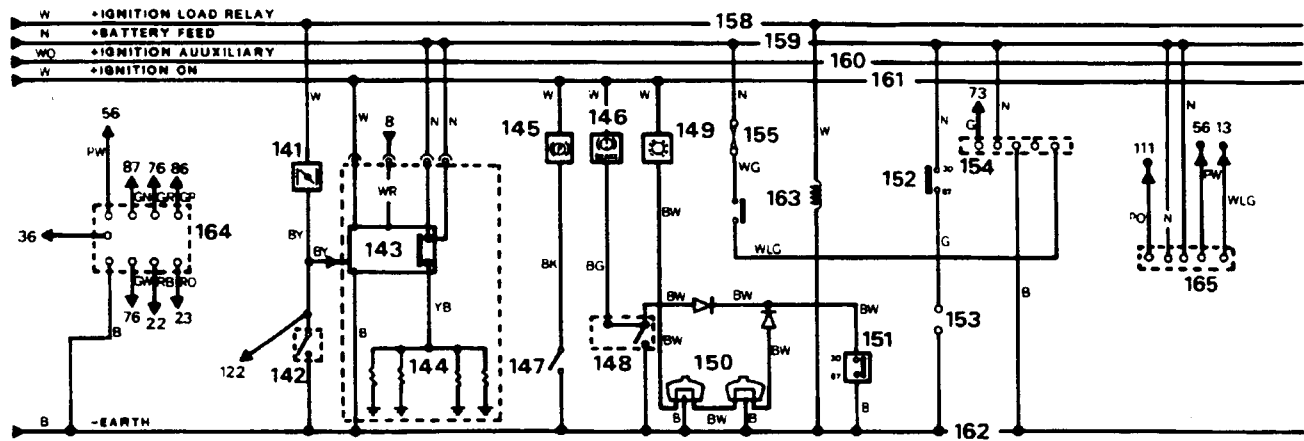
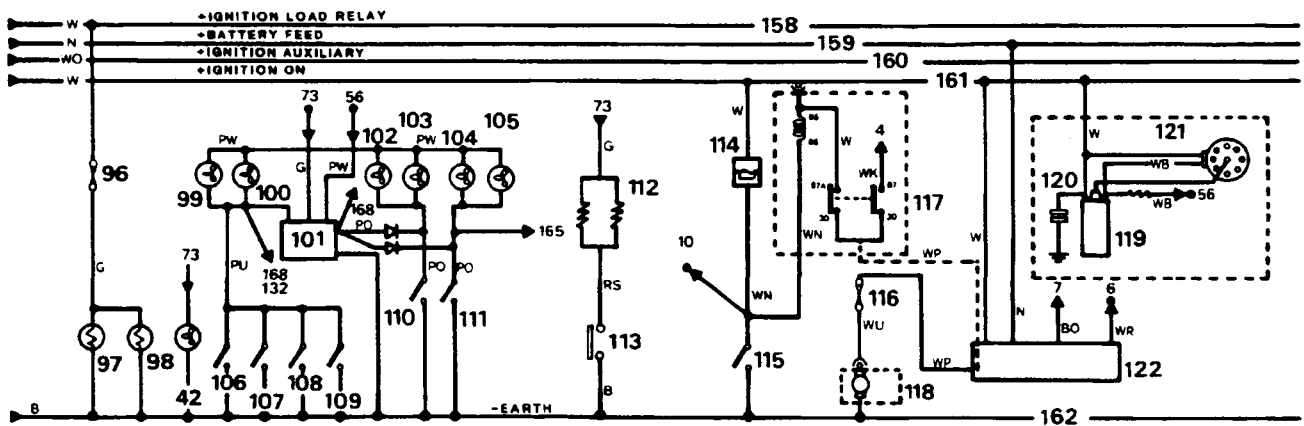
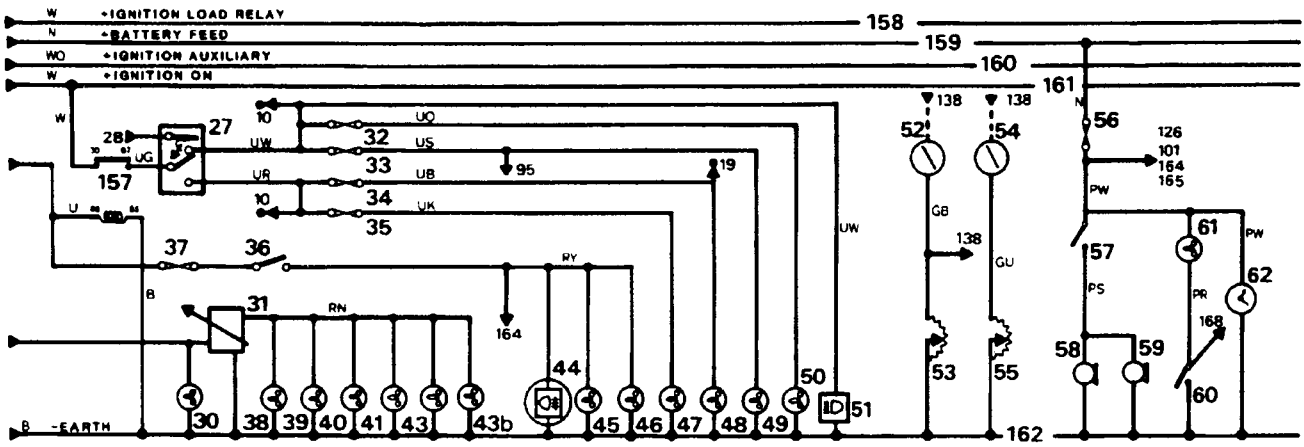

RR2572M

MAIN CIRCUIT DIAGRAM - NON CATALYST VEHICLES

Left hand Steering - RR2573M & RR2574M

Numerical key

1. Ignition load relay	59. Under bonnet light	119. Distributor
2. Battery	60. Clock	120. EFI Harness plug
3. Terminal post	61. Fuse 19	121. Fuel shut-off solenoid-Diesel
4. Starter solenoid	62. Fuse 20	122. Trailer pick up point
5. Starter motor	63. Pick-up point central locking/window lift	123. Radio fuse
6. Starter relay	64. Heated rear window relay	124. Radio
7. Starter inhibit switch (automatic)	65. Fuse 9	125. Four speakers
8. Ignition switch	66. Radio aerial amplifier	126. Alarm pick up point
9. Tachometer	67. Heated rear screen	127. Speed transducer, (Saudi only)
10. Ignition warning lamp	68. Heated rear screen switch	131. Seat buckle switch
11. Alternator	69. Heated rear screen warning lamp	132. Overspeed monitor (Saudi only)
12. Fuse 7	70. Voltage sensitive switch	133. Overspeed buzzer (Saudi only)
13. Front wipe/wash switch	71. Fuse 13	134. Sun roof pick up point (option)
14. Front wipe delay unit	72. Hazard switch	135. Automatic transmission oil temperature warning lamp
15. Front wiper motor	73. Flasher unit	136. Automatic transmission oil temperature switch
16. Front wash pump	74. Direction indicator switch	137. Fuse 16
17. Headlamp wash timer unit (option)	75. Hazard/indicator warning lamp	138. Rear wash wipe switch
18. Headlamp wash pump (option)	76. LH rear indicator lamp	139. Rear wipe delay unit
19. Main lighting switch	77. LH front indicator lamp	140. Rear wiper motor
20. Fuse 6	78. LH side repeater lamp	141. Rear screen wash pump
21. Fuse 5	79. RH side repeater lamp	142. Low screen wash fluid level warning lamp
22. LH side lamp	80. RH front indicator lamp	143. Low screen wash switch
23. LH tail lamp	81. RH rear indicator lamp	144. Low coolant switch
24. LH number plate lamp	82. Trailer warning lamp	145. Multi-function unit in binnacle
24 (a) RH number plate lamp	83. Fuse 15	146. Low coolant level warning lamp
25. Main beam dip/flash switch	84. Stop lamp switch	147. Low fuel level warning lamp
26. Headlamp relay	85. Reverse lamp switch	148. Cold start/Diesel glow plug warning lamp
27. RH side lamp	86. Auxiliary lamp relay	149. Choke switch - carburetter
28. RH tail lamp	87. LH stop lamp	150. Glowplug timer/Diesel
29. Rheostat	88. RH stop lamp	151. Glowplugs/Diesel
30. Fuse 3	89. LH reverse lamp	152. Handbrake/warning lamp
31. Fuse 4	90. RH reverse lamp	153. Handbrake warning switch
32. Fuse 1	91. LH auxiliary lamp (option)	154. Brake fluid level warning lamp
33. Fuse 2	92. RH auxiliary lamp (option)	154 (a) Brake fluid level warning switch
34. Rear fog switch	93. Auxiliary lamp switch (option)	155. Brake pad wear warning lamp
35. Fuse 12	94. Fuse 17	156. Brake pad wear sensors
36. Switch illumination (2 off)	95. Dash cigar lighter	157. Brake check unit
37. Cigar lighter illumination (2 off)	96. Cubby box cigar lighter	158. Split charge relay (option)
38. Heater illumination (4 off)	97. LH interior lamp	159. Split charge terminal post
39. Clock illumination	98. RH interior lamp	160. Heater/air conditioning connections
40. Automatic gear selector illumination (2 off)	99. Interior lamp delay unit	161. Fuse 8
41. Instrument illumination (6 off)	100. LH door edge lamp	162. Coil negative (engine RPM input to ECU)
41 (a) Column switch illumination	101. LH puddle lamp	163. Ignition load relay (+)
42. Rear fog warning lamp	102. RH door edge lamp	164. Battery feed (+)
43. LH rear fog	103. RH puddle lamp	165. Ignition auxiliary (+)
44. RH rear fog	104. Interior lamp switch	166. Ignition on (+)
45. LH dip beam	105. LH rear door switch	167. Earth (-)
46. RH dip beam	106. RH rear door switch	168. Warning lights common earth (-)
47. LH main beam	107. Tailgate switch	169. Warning lights supply (+)
48. RH main beam	108. LH front door switch	170. Electric seats pick up point (option)
49. Main beam warning lamp	109. RH front door switch	171. Fuse 14
50. Fuel gauge	110. Heated jets	173. Fuse 10
51. Fuel gauge sender unit	111. Thermostat-heated jets	174. Electric mirrors pick up point (option)
52. Water temperature gauge	112. Oil pressure warning lamp	175. Heater air/con relay
53. Water temperature sender unit	113. Oil pressure switch	
54. Fuse 11	114. Fuse 18	
55. Horn switch	115. Fuel shut-off relay - carburetter	
56. RH horn	116. Fuel pump - petrol models	
57. LH horn	117. Ignition coil	
58. Under bonnet illumination switch	118. Capacitor	

CABLE COLOUR CODE

B Black	L Light	P Purple	U Blue
G Green	N Brown	R Red	W White
K Pink	O Orange	S Grey	Y Yellow

The last letter of a colour code denotes the tracer.

MAIN CIRCUIT DIAGRAM - NON CATALYST VEHICLES

Left Hand Steering - RR2573M & RR2574M

Alphabetical key

126.	Alarm pick up point	83.	Fuse 15	19.	Main lighting switch
11.	Alternator	137.	Fuse 16	145.	Multi-function unit in binnacle
40.	Automatic gear selector illumination (2 off)	94.	Fuse 17	113.	Oil pressure switch
135.	Automatic transmission oil temperature warning lamp	114.	Fuse 18	112.	Oil pressure warning lamp
136.	Automatic transmission oil temperature switch	61.	Fuse 19	133.	Overspeed buzzer (Saudi only)
86.	Auxiliary lamp relay	62.	Fuse 20	132.	Overspeed monitor (Saudi only)
93.	Auxiliary lamp switch (option)	150.	Glowplug timer/Diesel	63.	Pick-up point central locking/window lift
2.	Battery	151.	Glowplugs/Diesel	92.	RH auxiliary lamp (option)
164.	Battery feed (+)	153.	Handbrake warning switch	46.	RH dip beam
157.	Brake check unit	152.	Handbrake/warning lamp	102.	RH door edge lamp
154.	Brake fluid level warning lamp	72.	Hazard switch	109.	RH front door switch
154 (a)	Brake fluid level warning switch	75.	Hazard/indicator warning lamp	80.	RH front indicator lamp
156.	Brake pad wear sensors	26.	Headlamp relay	56.	RH horn
155.	Brake pad wear warning lamp	18.	Headlamp wash pump (option)	98.	RH interior lamp
118.	Capacitor	17.	Headlamp wash timer unit (option)	48.	RH main beam
149.	Choke switch - carburetter	110.	Heated jets	24.(a)	RH number plate lamp
37.	Cigar lighter illumination (2 off)	67.	Heated rear screen	103.	RH puddle lamp
60.	Clock	68.	Heated rear screen switch	106.	RH rear door switch
39.	Clock illumination	69.	Heated rear screen warning lamp	44.	RH rear fog
162.	Coil negative (engine RPM input to ECU)	64.	Heated rear window relay	81.	RH rear indicator lamp
148.	Cold start/Diesel glow plug warning lamp	175.	Heater air/con relay	90.	RH reverse lamp
41.(a)	Column switch illumination	38.	Heater illumination (4 off)	27.	RH side lamp
96.	Cubby box cigar lighter	160.	Heater/air conditioning connections	79.	RH side repeater lamp
95.	Dash cigar lighter	55.	Horn switch	88.	RH stop lamp
74.	Direction indicator switch	165.	Ignition auxiliary (+)	28.	RH tail lamp
119.	Distributor	117.	Ignition coil	124.	Radio
120.	EFI Harness plug	1.	Ignition load relay	66.	Radio aerial amplifier
167.	Earth (-)	163.	Ignition load relay (+)	123.	Radio fuse
174.	Electric mirrors pick up point (option)	166.	Ignition on (+)	34.	Rear fog switch
170.	Electric seats pick up point (option)	8.	Ignition switch	42.	Rear fog warning lamp
73.	Flasher unit	10.	Ignition warning lamp	141.	Rear screen wash pump
125.	Four speakers	41.	Instrument illumination (6 off)	138.	Rear wash wipe switch
16.	Front wash pump	99.	Interior lamp delay unit	139.	Rear wipe delay unit
14.	Front wipe delay unit	104.	Interior lamp switch	140.	Rear wiper motor
13.	Front wipe/wash switch	91.	LH auxiliary lamp (option)	127.	Speed transducer, (Saudi only)
15.	Front wiper motor	45.	LH dip beam	158.	Split charge relay (option)
50.	Fuel gauge	100.	LH door edge lamp	159.	Split charge terminal post
51.	Fuel gauge sender unit	108.	LH front door switch	7.	Starter inhibit switch (automatic)
116.	Fuel pump - petrol models	77.	LH front indicator lamp	5.	Starter motor
115.	Fuel shut-off relay - carburetter	57.	LH horn	6.	Starter relay
121.	Fuel shut-off solenoid-Diesel	97.	LH interior lamp	4.	Starter solenoid
32.	Fuse 1	47.	LH main beam	84.	Stop lamp switch
33.	Fuse 2	24.	LH number plate lamp	134.	Sun roof pick up point (option)
30.	Fuse 3	101.	LH puddle lamp	36.	Switch illumination (2 off)
31.	Fuse 4	105.	LH rear door switch	9.	Tachometer
21.	Fuse 5	43.	LH rear fog	107.	Tailgate switch
20.	Fuse 6	76.	LH rear indicator lamp	3.	Terminal post
12.	Fuse 7	89.	LH reverse lamp	111.	Thermostat-heated jets
161.	Fuse 8	22.	LH side lamp	122.	Trailer pick up point
65.	Fuse 9	78.	LH side repeater lamp	82.	Trailer warning lamp
173.	Fuse 10	87.	LH stop lamp	58.	Under bonnet illumination switch
54.	Fuse 11	23.	LH tail lamp	59.	Under bonnet light
35.	Fuse 12	146.	Low coolant level warning lamp	70.	Voltage sensitive switch
71.	Fuse 13	144.	Low coolant switch	168.	Warning lights common earth (-)
171.	Fuse 14	147.	Low fuel level warning lamp	169.	Warning lights supply (+)
		142.	Low screen wash fluid level warning lamp	52.	Water temperature gauge
		143.	Low screen wash switch	53.	Water temperature sender unit
		25.	Main beam dip/flash switch		
		49.	Main beam warning lamp		

86 ELECTRICAL EQUIPMENT

MAIN CIRCUIT DIAGRAM - NON CATALYST Left hand steering - RR2573M & RR2574M

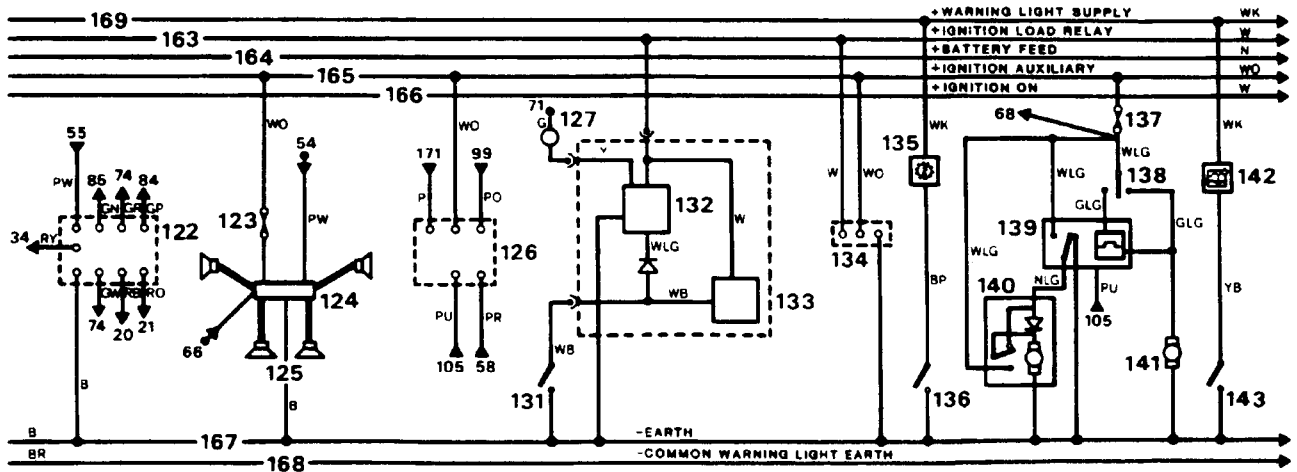
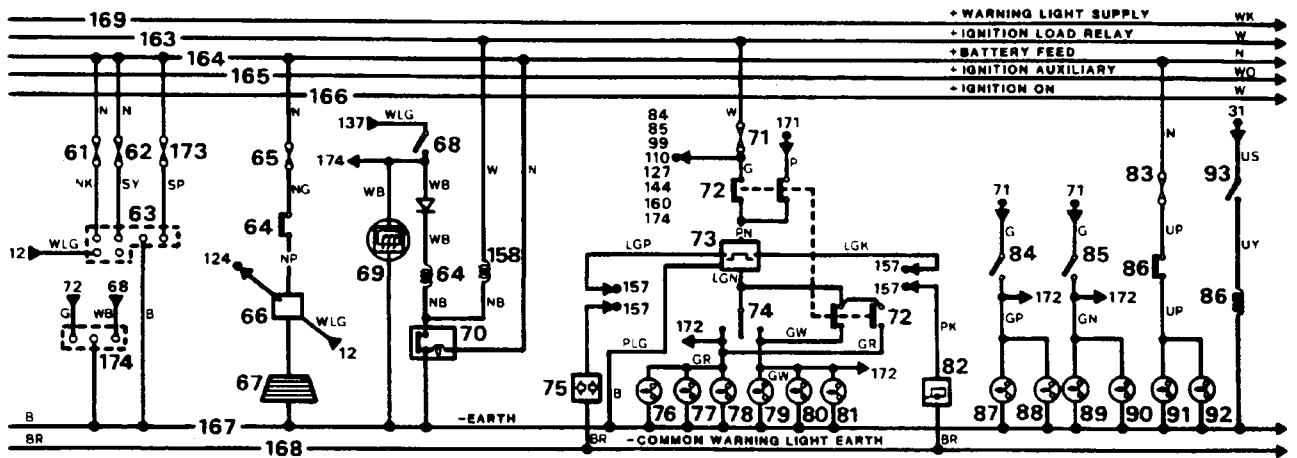
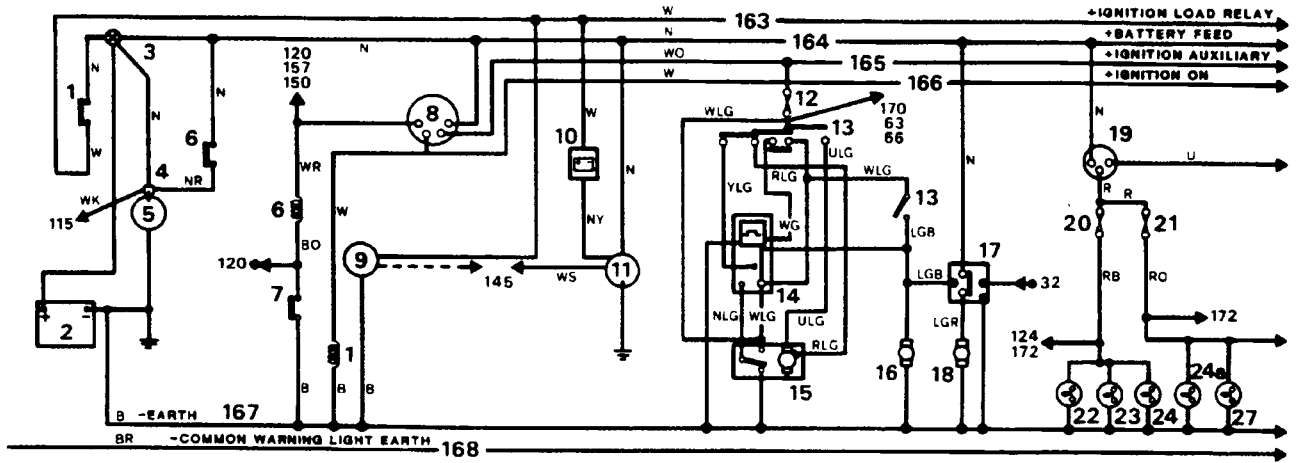

RR2573M

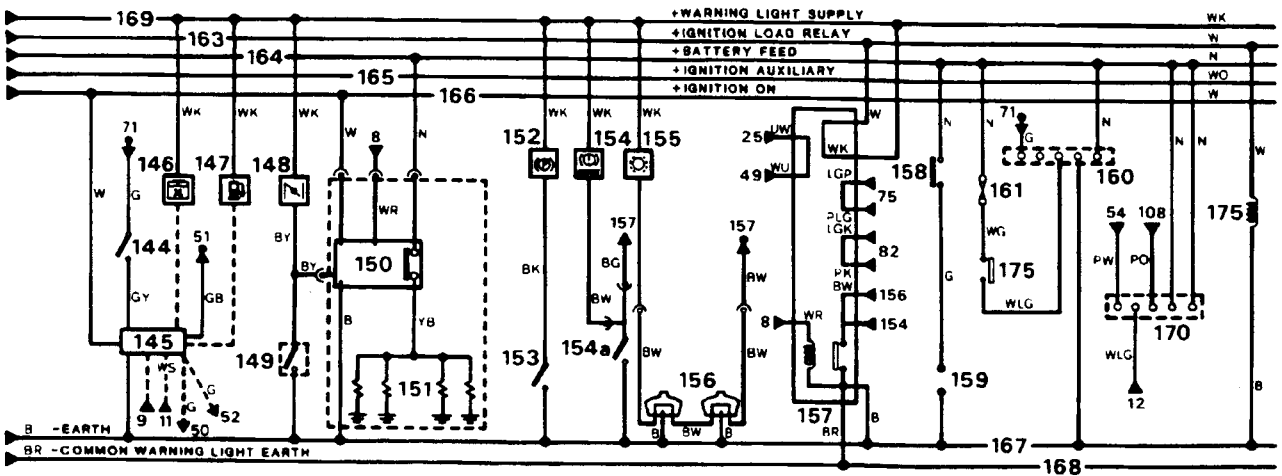
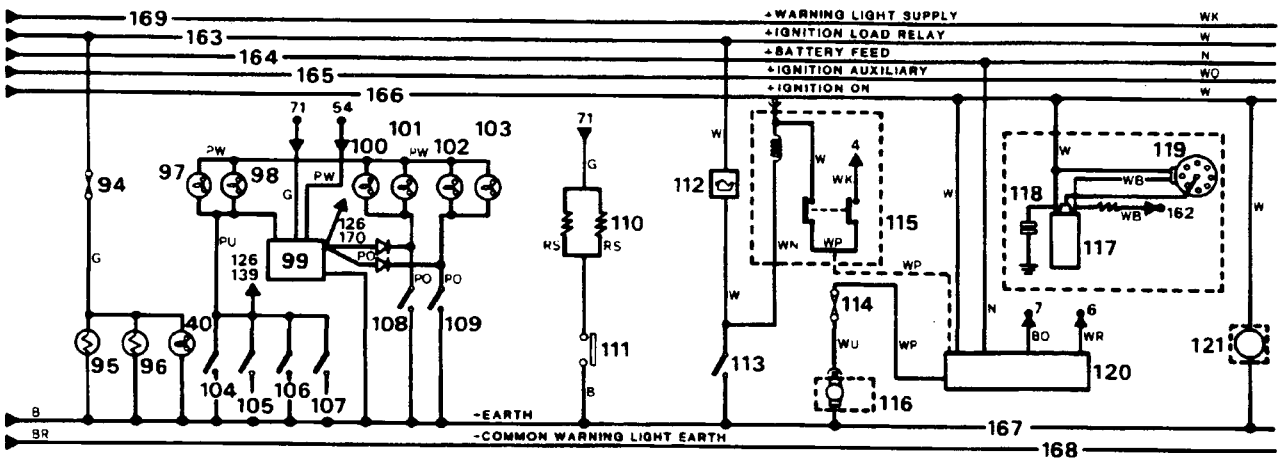
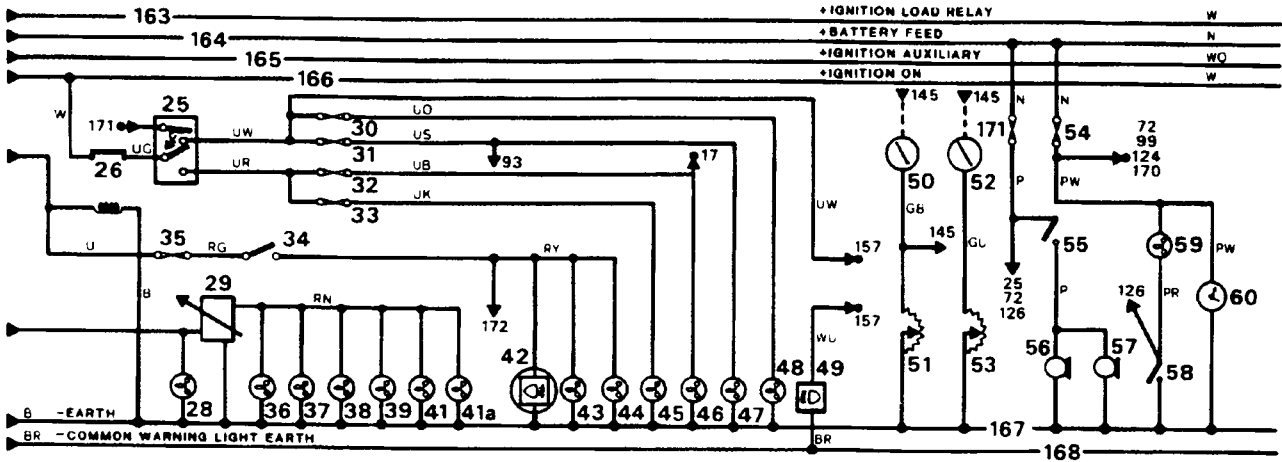

RR2574M

