

47 - PROPELLER SHAFTS

CONTENTS

Page

DESCRIPTION AND OPERATION

PROPELLER SHAFT ALIGNMENT 1

FAULT DIAGNOSIS

VIBRATION HARSHNESS 1

OVERHAUL

PROPELLER SHAFTS FRONT AND REAR 1





PROPELLER SHAFT ALIGNMENT

Description

The front and rear propeller shafts have non-constant velocity 'Hooks' type universal joints, with needle roller bearings. The bearing cups are pre-packed with lubricant on assembly and a grease nipple is fitted for servicing as specified, in maintenance section.

Both shafts have plain sliding splines to accommodate the variation in distance between the axles and transmission. The splines are pre-packed with lubricant and sealed.

The bearing yokes on the rear shaft are conventionally aligned, with the yokes A and B on each end of the shaft are aligned to one another as seen in RR3642M.

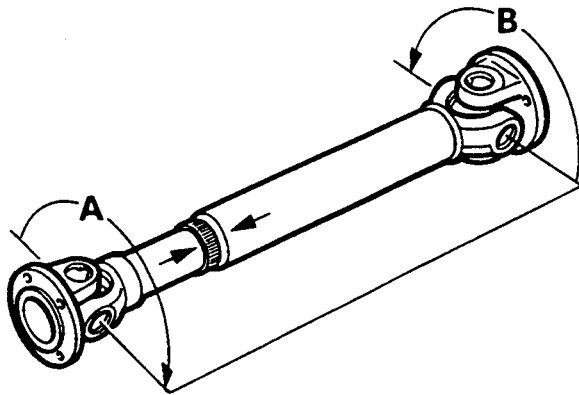

RR3642M

The front shaft which is shorter than the rear is 'Phased', with the joints at each end, A and B miss-aligned as shown in RR3643M.

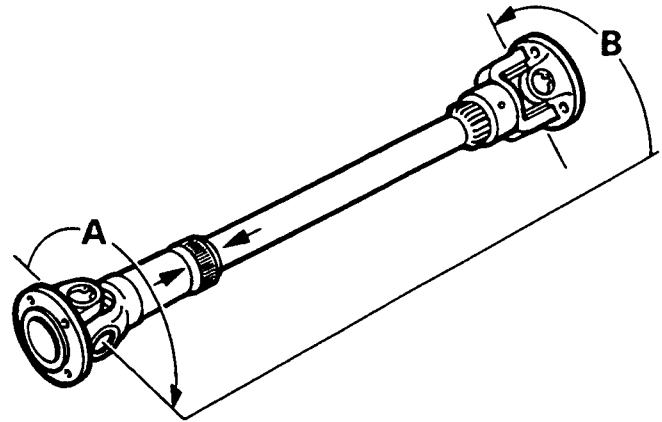

RR3643M

The phasing is necessary on the front shaft only to allow for greater variation in angular changes.

Both halves of each shaft are marked with an arrow, which must be aligned to ensure any phasing and correct original balance is retained.



VIBRATION HARSHNESS

1. Check that the propeller shaft universal joints and sliding splines are not siezed or worn and that the shafts are correctly aligned.



NOTE: In the event that both shafts are satisfactory, but the vibration/harshness is still present, the transfer box operation and balance of the road wheels should be checked.

For transfer box operation. *See TRANSFER BOX, Fault diagnosis, Borg Warner - Symptoms*

For balance of road wheels. *See WHEELS AND TYRES, Repair, Wheel balancing*



PROPELLER SHAFTS FRONT AND REAR

Overhaul

1. Place vehicle over pit or on a ramp.
2. Remove nuts from each end of propeller shaft. Remove shaft.
3. Note alignment markings on propeller shaft front and rear.

FRONT PROPELLER SHAFT

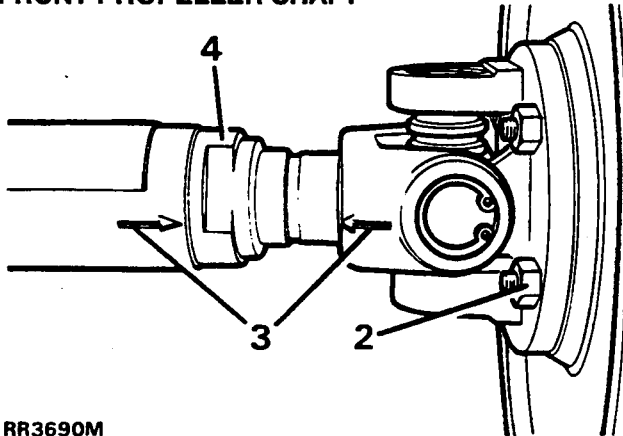

RR3690M

REAR PROPELLER SHAFT

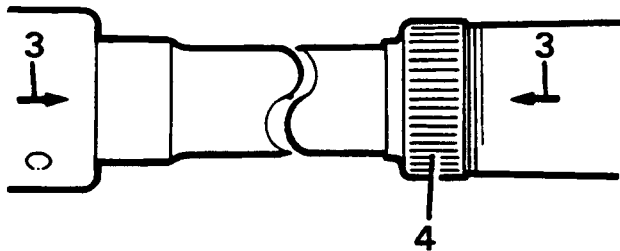

RR3691M

4. Unscrew dust cap and withdraw sliding member.

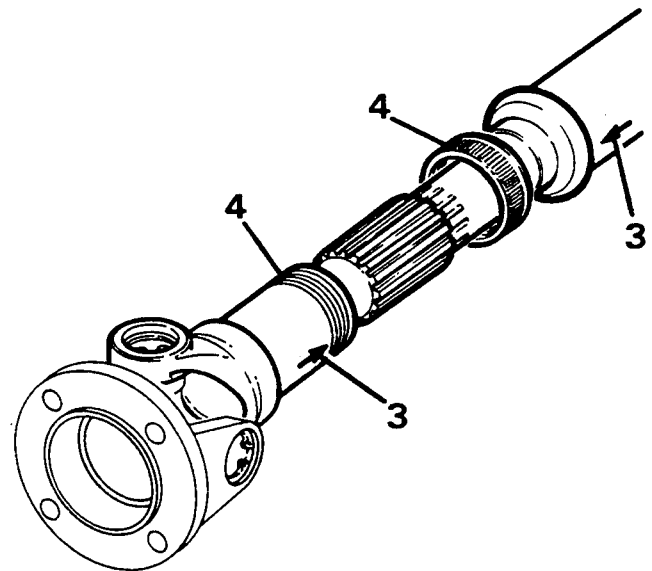

RR1999E

5. Examine splines for wear. Worn splines will require drive shaft replacement.
6. Clean universal joint bearing cups and circlips.



CAUTION: To ensure correct assembly and reduce possibility of imbalance. Before removing propeller shaft joint. Mark position of spider pin lubricator relative to journal yoke ears.

7. Remove circlips, and grease nipple.

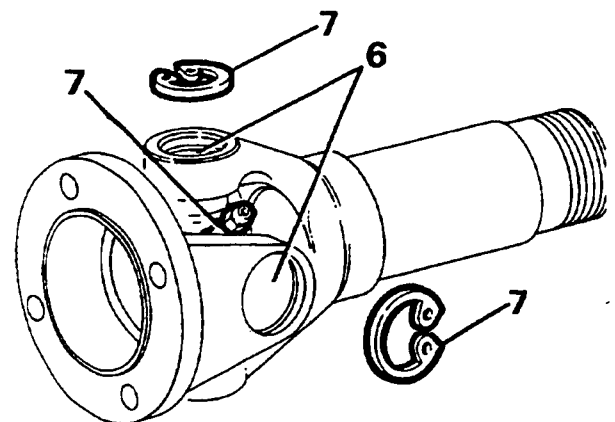

RR2001E

8. Tap yokes to eject bearing cups.

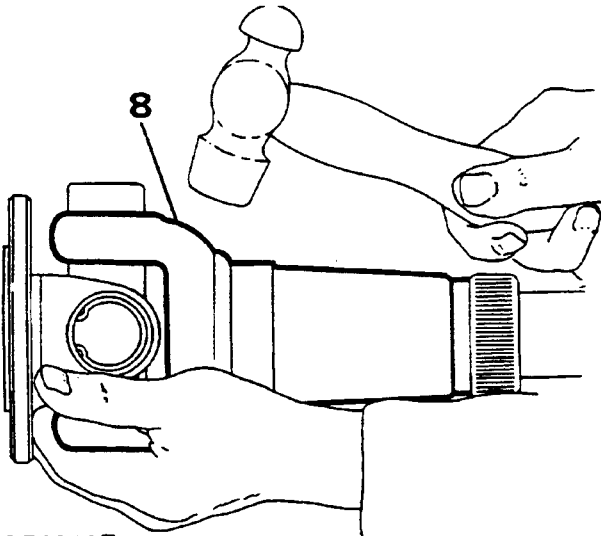

RR2002E

9. Remove bearing cups and spider.
10. Repeat instructions 5 to 8 for opposite end of propeller shaft.
11. Clean yokes and bearing cup locations.

Assemble

12. Remove bearing cups from new spider.
13. Check all needle rollers are present and positioned in bearing cups.
14. Ensure bearing cups are one-third full of lubricant. *See LUBRICANTS, FLUIDS AND CAPACITIES, Information, Recommended lubricants and fluids*
15. Enter new spider with seals into yokes of sliding member flange.
16. Partially insert one bearing cup into flange yoke and enter spider trunnion into bearing cup.
17. Insert opposite bearing cup into flange yoke.
18. Press both cups into place.

19. Press each cup into its respective yoke up to lower land of circlip grooves. Damage may be caused to cups and seals if cups pass this point.
20. Fit circlips.
21. Engage spider in yokes of sliding member. Fit bearing cups and circlips as described in instructions 15 to 20.

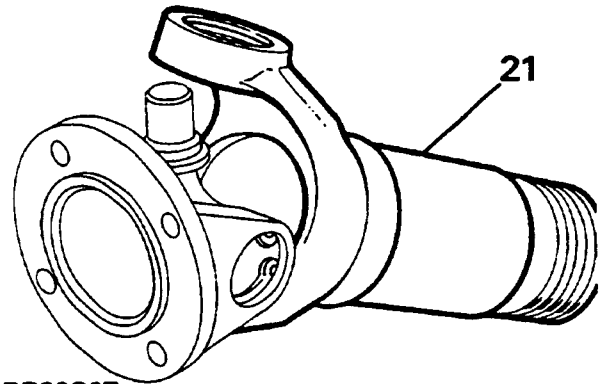

RR2003E

22. Lubricate sliding member splines and fit sliding member to propeller shaft. Ensure markings on both sliding member and propeller shaft align.
23. Fit and tighten dust cap.
24. Fit grease nipples to spider and sliding member.
25. Apply instructions 15 to 20 to opposite end of propeller shaft.
26. Fit grease nipple and lubricate.

Refit

27. Fit propeller shafts to vehicle. Tighten nuts to **47Nm**
Refit FRONT propeller shaft so sliding joint end of shaft is fitted to transfer gearbox.
Refit REAR propeller shaft so sliding joint end of shaft is fitted to handbrake drum.

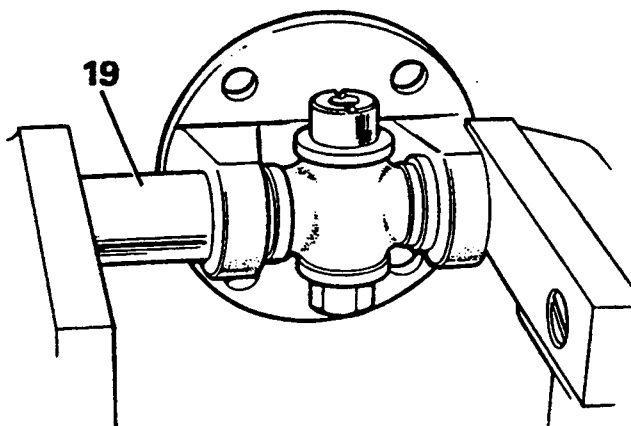

ST1005M



SPIDER ASSEMBLY COMPONENTS

1. Circlip
2. Bearing cup
3. Nylatron washer
4. Needle rollers (27 per cup)
5. Seal retainer
6. Seal

